

**Advances in Integrated Soil Fertility Management in sub-Saharan Africa:
Challenges and Opportunities**

Advances in Integrated Soil Fertility Management in sub-Saharan Africa: Challenges and Opportunities

Edited by

Andre Bationo

Tropical Soil Biology and Fertility (TSBF) Institute of the International Centre for Tropical Agriculture (TSBF-CIAT), Nairobi, Kenya

Boaz Waswa

Tropical Soil Biology and Fertility (TSBF) Institute of the International Centre for Tropical Agriculture (TSBF-CIAT), Nairobi, Kenya

Job Kihara

Tropical Soil Biology and Fertility (TSBF) Institute of the International Centre for Tropical Agriculture (TSBF-CIAT), Nairobi, Kenya

Joseph Kimetu

Tropical Soil Biology and Fertility (TSBF) Institute of the International Centre for Tropical Agriculture (TSBF-CIAT), Nairobi, Kenya

A C.I.P. Catalogue record for this book is available from the Library of Congress.

ISBN-13 978-1-4020-5759-5 (HB)

ISBN-13 978-1-4020-5760-1 (e-book)

Published by Springer,
P.O. Box 17, 3300 AA Dordrecht, The Netherlands.
www.springer.com

Printed on acid-free paper

Top left- Response to P fertilizer by soybeans
Top Middle- Millet cowpea rotation system: a promising technology in the drylands
Top Right- Integrating high value crops such as tomatoes in research portfolio of AfNet
Bottom left- Response of maize to fertilizer in farmer managed trials
Bottom Middle- Participatory research: A tool widely used by AfNet Scientists
Bottom Right- Tapping the potential of the banana-based cropping systems

All Rights Reserved

© 2007 Springer

No part of this work may be reproduced, stored in a retrieval system, or transmitted in any form or by any means, electronic, mechanical, photocopying, microfilming, recording or otherwise, without written permission from the Publisher, with the exception of any material supplied specifically for the purpose of being entered and executed on a computer system, for exclusive use by the purchaser of the work.

Contents

Preface	xiii
---------	------

Part I: Setting the scene/Introductory papers

1. A critical analysis of challenges and opportunities for soil fertility restoration in Sudano-Sahelian West Africa <i>Schlecht E., Buerkert A., Tielkes E. and Bationo A.</i>	1
2. Appropriate technologies to replenish soil fertility in southern Africa <i>Mafongoya P.L., Bationo A., Kihara J. and Waswa B.S.</i>	29
3. Available technologies to replenish soil fertility in Eastern Africa <i>Okalebo J.R., Othieno C.O., Woomer P.L., Karanja N.K., Semoka J.R.M., Bekunda M.A., Mugendi D.N., Muasya R.M., Bationo A. and Mukhwaua E.J.</i>	45
4. Integrated Agricultural Research for Development: contributing to the Comprehensive Africa Agricultural Development Programme (IAR4D in CAADP) <i>Ralph von Kaufmann</i>	63
5. From Thousands to Millions: Accelerating Agricultural Intensification and Economic Growth in Sub-Saharan Africa <i>Maatman A., Wopereis M.C.S., Debrah K.S. and Groot J.J.R.</i>	75
6. Soil science, population growth and food production: some historical developments <i>Alfred E. Hartemink</i>	85
7. Development of an arable layer: A key concept for better management of infertile tropical savanna soils <i>Amézquita E., Rao I.M., Hoyos P., Molina D., Chavez L.F. and Bernal J.H.</i>	99
8. Food Security in Africa: The Challenges of Researchers in the 21 st Century <i>James B. Kung'u</i>	105
9. Background, Current status and the African Context of the International Nitrogen Initiative <i>Mateete Bekunda, James Galloway, Keith Syers and Mary Scholes</i>	115

Part II: Integrated Nutrient Management (INM)

10. Within-Farm soil fertility gradients affect response of maize to fertiliser application in western Kenya <i>Vanlauwe B., Tittonell, P. and Mukalama, J.</i>	121
11. Characterisation of soil degradation under intensive rice production in Office du Niger zone of Mali <i>Minamba Bagayoko, Mamadou K. N'Diaye, Mohamed Dicko and Bréhima Tangara</i>	133
12. Soil fertility issues in the Blue Nile Valley, Ethiopia <i>Per Ivar Våje</i>	139

13.	Overcoming phosphorus deficiency in soils of Eastern Africa: recent advances and challenges <i>Generose Nziguheba</i>	149
14.	Relative contribution of trees and crops to soil carbon content in a parkland system in Burkina Faso using variations in natural ¹³ C abundance <i>Bayala J., Balesdent J., Marol C., Zapata F., Teklehaimanot Z. and Ouedraogo S.J.</i>	161
15.	Mineral fertilizers, organic amendments and crop rotation managements for soil fertility maintenance in the Guinean zone of Burkina Faso (West Africa) <i>B.V. Bado, A. Bationo, Lompo, F, M.P. Cescas and M.P Sedogo</i>	171
16.	Effect of planting technique and amendment type on pearl millet yield, nutrient uptake, and water use on degraded land in Niger <i>Fatondji D., C. Martius, C.L. Biielders, P.L.G. Vlek , A. Bationo and B. Gerard</i>	179
17.	Short-term effects of cover crops on stem borers and maize yield in the humid forest of southern Cameroon <i>Chabi-Olaye A., Nolte C., Schulthess F. and Borgemeister C.</i>	195
18.	Improving cereal productivity and farmers' income using a strategic application of fertilizers in West Africa <i>Ramadjita Tabo, Andre Bationo, Bruno Gerard, Jupiter Ndjeunga, Daniel Marchal, Bassirou Amadou, Mallam Garba Annou, Diakala Sogodogo, Jean-Baptiste Sibiry Taonda, Ousmane Hassane, Maimouna K. Diallo and Saidou Koala</i>	201
19.	Advances in improving Agricultural Profitability and Overcoming Land Degradation in Savanna and Hillside Agroecosystems of Tropical America <i>M. Ayarza, E. Barrios, I. Rao, E. Amézquita and M. Rondón</i>	209
20.	Integrating legumes to improve N cycling on smallholder farms in sub-humid Zimbabwe: Resource quality, biophysical and environmental limitations <i>Regis Chikowo, Paul Mapfumo, Peter A Leffelaar and Keu E Giller</i>	231
21.	Meat and bone meal as nitrogen and phosphorus fertilizer to cereals and rye grass <i>Alhaji S. Jeng, Trond Knapp Haraldsen, Arne Grønland and Per Anker Pedersen</i>	245
22.	Screening Legume Green Manure for Climatic Adaptability and Farmer Acceptance in the Semi-Arid Agro-ecological Zone of Uganda <i>J.B. Tumuhairwe, M.C. Rwakaikara-Silver, S. Muwanga and S. Natigo</i>	255
23.	Nutrient flows in smallholder production systems in the humid forest zone of southern Cameroon <i>J. Kanmegne, Smaling E.M.A., Brussaard L., Gansop-Kouomegne A. and A. Boukong</i>	261
24.	Management of improved fallows for soil fertility enhancement in the western highlands of Cameroon <i>Meppe F., Bilong P. and Nwaga D.</i>	277
25.	Integrated Soil Fertility Management: Use of NUTMON to Quantify Nutrient Flows in Farming Systems in Central Kenya <i>Kathuku A.N., S.K. Kimani, J.R. Okalebo, C.O. Othieno and B. Vanlauwe</i>	283
26.	Optimizing Soil Fertility Gradients in the Enset (<i>Ensete ventricosum</i>) Systems of the Ethiopian Highlands: Trade-offs and Local Innovations <i>Tilahun Amede and Endale Taboge</i>	289
27.	Consequences of Field Management and Soil Erosion on the Sustainability of Large Scale Coffee Farming in Kiambu <i>Okoth P.F., Ng'ang'a J.K. and Kimani P.K.</i>	299

28. The Use of Erosion Proxies for the Spatial Assessment of Erosion in a Watershed and Modelling the Erosion Risk in a GIS 311
Okoth P.F., Oketch P.A. and Kimani P.K.
29. Bean Improvement for Low Soil Fertility Adaptation in Eastern and Central Africa 325
Lunze L., Kimani P.M., Ngatoluwa R., Rabary B., Rachier G.O., Ugen M.M., Vicky Ruganza and Awad elkarim E.E.
30. Combining *Tithonia diversifolia* and minjingu phosphate rock for improvement of P availability and maize grain yields on a chromic acrisol in Morogoro, Tanzania 333
S.T. Ikerra, E. Semu and J.P. Mrema
31. Improving food production using 'best bet' soil fertility technologies in the Central highlands of Kenya 345
Daniel Mugendi, Monicah Mucheru-Muna, Jayne Mugwe, James Kung'u and Andre Bationo
32. Effects of organic and mineral sources of nutrients on maize yields in three districts of central Kenya 353
Kimani S.K., Esilaba A.O., Odera M.M., Kimenye L., Vanlauwe B. and Bationo A.
33. Effect of Combining Organic Leafy Biomass and Inorganic fertilizer on Tomato Yields and nematodes control in Arenosols in Kinshasa Area 359
Mafuka M. M., Nsombo M., Nkasa C. Ibwenzi K. and Taba K.
34. Nutrient Dynamics On Smallholder Farms In Teghane, Northern Highlands Of Ethiopia 365
Assefa Abegaz, Herman van Keulen, Mitiku Haile and Simon J. Oosting
35. Nitrogen-15 Recovery in Cropped Soil Cores Fertilized With Potassium Nitrate and Clover Residues 379
Anne W. Muriuki, Larry D. King and Richard J. Volk
36. Evaluation of nitrogen fixation using ¹⁵N dilution methods and economy of a maize-tepyary bean intercrop farming system in semi-arid SE-Kenya 389
Chris A. Shisanya and Nkanata M. Gitonga
37. Evaluation of cowpea genotypes for variations in their contribution of N and P to subsequent maize crop in three agro-ecological zones of West Africa 401
R.C. Abaidoo, J.A. Okogun, G.O. Kolawole, J. Diels, P. Randall and N. Sanginga
38. Variability of cowpea breeding lines to low phosphorus tolerance and response to external application of Phosphorus 413
A.K. Saidou R.C. Abaidoo, B.B. Singh, E.N.O. Iwuafor and N. Sanginga
39. The potential benefits of *Azolla*, Velvet bean (*Mucuna pruriens* var. *utilis*) and N fertilizers in rice production under contrasting systems in eastern Uganda 423
Crammer K. Kaizzi, Henry Ssali, Angella Nansamba and Paul, L.G. Vlek
40. Tied-ridging and integrated nutrient management options for sustainable crop production in semi-arid eastern Kenya 435
Miriti J.M., Esilaba A.O., Bationo A., Cheruiyot H., Kihumba J. and Thurania E.G.
41. Economic evaluation of local inputs in Meru South District, Kenya 443
Monicah Mucheru-Muna, Daniel Mugendi, Jayne Mugwe and James Kung'u
42. Effect of Rock Phosphate, Lime and Green Manure on Growth and Yield of Maize in a Non Productive Niche of a Rhodic Ferralsol in Farmer's Fields 449
Tabu I.M., Bationo A., Obura R.K. and Khaemba J.M.

- | | | |
|-----|--|-----|
| 43. | Changes in Soil Organic Matter as Influenced by Organic Residue Management Regimes in Selected Experiments in Kenya
<i>Waswa B.S., Mugendi D.N., Vanlauwe B. and Kung'u J.</i> | 457 |
| 44. | Effects of manure application on crop yield and soil chemical properties in a long-term field trial in semi-arid Kenya
<i>Kihanda F.M., Warren G.P. and Micheni A.N.</i> | 471 |
| 45. | Nutrient Recovery from Solid Waste and Linkage to Urban and Peri-Urban Agriculture in Nairobi, Kenya
<i>Mary Njenga, Stephen Kimani, Dannie Romney and Nancy Karanja,</i> | 487 |
| 46. | Optimising crop productivity in legume-cereal rotations through nitrogen and phosphorus management in western Kenya
<i>Kihara J., Kimetu J.M., Vanlauwe B., Bationo A., Waswa B. and Mukalama J.</i> | 493 |
| 47. | Evaluation of the Potential of Using Nitrogen Fixing Legumes in Smallholder Farms of Meru South District, Kenya
<i>Jayne Mugwe, Daniel Mugendi, David Odee and John Otieno</i> | 503 |
| 48. | Improved cassava varieties increase the risk of soil nutrient mining: an ex-ante analysis for western Kenya and Uganda
<i>Fermont A.M., Obiero H.M., van Asten P.J.A., Baguma Y. and Okwuosa E.</i> | 511 |
| 49. | Partial balance of nitrogen in a maize cropping system in humic nitisol of Central Kenya
<i>J.M. Kimetu, D.N. Mugendi, A. Bationo, C.A. Palm, P.K. Mutuo, J. Kihara, S. Nandwa and K. Giller</i> | 521 |
| 50. | Integrated Soil Fertility Management Technologies: A Counteract to Existing Milestone in Obtaining Achievable Economical Crop Yields in Cultivated Lands of Poor Smallholder Farmers in Malawi
<i>Moses Wazingwa Munthali</i> | 531 |
| 51. | Fertilizer nitrogen recovery as affected by soil organic matter status in two sites in Kenya
<i>Karunditu M.W., Mugendi D.N., Kung'u J. and Vanlauwe B.</i> | 537 |
| 52. | Performance evaluation of various agroforestry species used in short duration improved fallows to enhance soil fertility and sorghum yields in Mali
<i>Bocary Kaya, Amadou Niang, Ramadjita Tabo and André Bationo</i> | 547 |
| 53. | Nutrient balances for different farm types in Southern Mali
<i>S. Kanté, E.M.A. Smaling and H. van Keulen</i> | 557 |
| 54. | Increasing the Productivity and Sustainability of Millet Based Cropping Systems in the Sahelian Zones of West Africa
<i>Traoré Samba, Birama S. Coulibaly, Amadou Koné, Minamba Bagayoko and Zoumana Kouyaté</i> | 567 |
| 55. | Comparative short-term effects of different quality organic resources on maize productivity under two different environments in Zimbabwe
<i>Florence Mtambanengwe, Paul Mapfumo and Bernard Vanlauwe</i> | 575 |
| 56. | Improving soil fertility through the use of organic and inorganic plant nutrient and crop rotation in Niger
<i>Adamou A., Bationo A., Tabo R. and Koala S.</i> | 589 |
| 57. | Biological system for improving the availability of Tilemsi phosphate rock for wheat (<i>Triticum aestivum L</i>) cultivated in Mali
<i>A.H. Babana and H. Antoun</i> | 599 |

58. Managing manure heaps with agro-organic wastes and cover to reduce nitrogen losses during storage on smallholder farms 611
Gichangi E.M., Karanja N.K. and Wood C.W.
59. Soil characteristics and the performance of sorghum (*Sorghum bicolor* (L) Moench) on tin mine spoils of the Jos Plateau, Nigeria 619
A.A. Yusuf, A.F. Eben-Johnson, V.O. Chude and I.Y. Amapu
60. The development of a prototype land information system for the northern Guinea savanna of Nigeria as a basis for agro-technology transfer 629
Tabi F.O., Ogunkunle A.O. and Diels J.
61. What role can planted fallows play in the humid and sub-humid zone of West and Central Africa? 647
Stefau Hauser, Christian Nolte and Robert J. Carsky
62. Balanced Nutrient Management System Technologies In The Northern Guinea Savanna Of Nigeria: Validation And Perspective 669
Kolawole G.O., Diels J., Manyong V.M., Ugbabe O., Wallays K., Dercon G., Iwuafor E.N.O., Falaki A.M., Merckx R., Deckers J., Tollens E., Vanlauwe B. and Sanginga N.
63. Soil Erosion and Soil Inorganic-N Depletion as Influenced by Live hedges in Arable Steep-lands of the Central Highlands of Kenya 679
James K. Mutegi, Daniel N. Mugendi, Louis V. Verchot and James B. Kungu
64. Relationships between rhizobial diversity and host legume nodulation and nitrogen fixation in tropical ecosystems 691
Abdullahi Bala and Ken E. Giller
65. Limestone, Minjingu Phosphate Rock and Green Manure Application on Improvement of Acid Soils in Rwanda 703
Nabahungu N.L, Semoka J.M.R and Zaongo C.
66. Evaluating performance and yield stability of some groundnut (*Arachis hypogaea* L.) varieties under irrigation in three agroecological zones of the Senegal River Valley 713
Madiama CISSE and Souleymane DIALLO
67. Assessment of the contribution of tied ridges and farmyard manure application to sorghum production in semi-arid areas of Tanzania 723
Kabanza A.K. and Rwehumbiza F.B.R.
68. Evaluation of *Gliricidia sepium*, *Casuarina junghuhniana* and *Faidherbia albida* tree species for improvement of crop production and fuelwood supply in Muheza districts, Tanzania 731
Joel L. Meliyo, Marandu A.E.T. and Munuo E.
69. Mineral N distribution in the soil profile of a maize field amended with cattle manure and mineral N under humid sub-tropical conditions 737
Nyamangara J.
70. Intensity cultivation induced effects on soil organic carbon dynamic in the western cotton area of Burkina Faso 749
Badiori Ouattara, Korodjouma Ouattara, Georges Serpantié, Abdoulaye Mando, Michel P. Sédogo and André Bationo
71. Assessment of improved soil fertility and water harvesting technologies through community based on-farm trials in the ASALs of Kenya 759
Gichangi E.M., Njiru E.N., Itabari J.K., Wambua J.M., Maina J.N. and Karuku A.

72. Profitability of agro-forestry based soil fertility management technologies: the case of small holder food production in Western Kenya 767
J.M. Maithya, L.N. Kimenye, F.I. Mugivane and J.J. Ramisch
73. Integrated natural resources management a strategy for food security and poverty alleviation in Kwalei village, Lushoto district, Tanzania 781
Joel L. Meliyo, K.F.G. Masuki and J.G. Mowo
74. Effects of total inorganic nitrogen and phosphorus availability on Maize Yields in the First post *Tephrosia vogelii* fallow 787
Mkangwa C.Z., Maliondo S.M.S. and Semoka J.M.R.
75. Environmental hazards in African agriculture: factors influencing application of agrochemicals in Nakuru district, Kenya 795
Lagat J.K., Wangia S.M., Njehia B.K. and Ithinji G.K.
76. Assessment of indigenous soil and water conservation technology for smallholder farms in semi-arid areas in Africa and close spaced trash lines effect on erosion and crop yield 805
Isaiah I.C. Wakindiki, B.O. Mochoge and Meni Ben-Hur

Part III: Belowground biodiversity

77. *Prosopis africana* (Guill., Perrot et Rich.) Taub and *Entada africana* (Guill. et Perrot.) leaf litter decomposition and impact of biomass transfer on millet (*Pennisetum glaucum* (L.) R. Br.) growth and development on station in Niger 815
Larwanou Mahamane, Harouna Niandou Abdel-Aziz, Abasse Tougiani and Niang Amadou
78. Soil microbial biomass carbon and nitrogen as influenced by organic and inorganic inputs at Kabete, Kenya 827
Baaru M.W., Mugendi D.N., Bationo A., Verchot L. and Waceke W.
79. Evaluating effect of mixtures of organic resources on nutrient release patterns and uptake by maize 833
F.O. Ayuke, N.K. Karanja and S.W. Bunyasi
80. Mycorrhizal associations as indicators of forest quality after land use practices 845
Onguene N.A.
81. Biomass production, N and P uptake of *Mucuna* after Bradyrhizobia and Arbuscular mycorrhizal fungi inoculation, and P-application on acid soil of Southern Cameroon 855
Jemo M., Nolte C. and Nwaga D.
82. Evaluating the effect of *Bacillus* and *Rhizobium*. bi-inoculant on nodulation and nematode control in *Phaseolus vulgaris* L. 865
Karanja N.K., Mutua G.K. and Kimenju J.W.

Part IV: Participatory Approaches and Scaling up/out

83. Integrated Soil Fertility Management Technologies: review for scaling up 873
Michael Misiko and Joshua Ramisch
84. Costs and Returns of Soil Fertility Management Options in Western Kenya 881
Paul L. Woomer
85. Modeling farmers' decisions on integrated soil nutrient management in sub-Saharan Africa: A multinomial Logit analysis in Cameroon 891
Guy Blaise Nkamleu

Contents	xi
86. Opportunities for and constraints to adoption of improved fallows: ICRAF's experience in the humid tropics of Cameroon <i>Degrande A., Asaah E., Tchoundjeu Z., Kanmegne J., Duguma B. and Franzel S.</i>	905
87. The Effect of Socio-Economic Factors on a Farmer's Decision to Adopt Farm Soil Conservation Measures. An Application of Multivariate Logistic Analysis in Butere/Mumias District, Kenya <i>Victoria E. Anjichi and L.W. Mauyo</i>	915
88. Farmer's perception of planted calliandra tree fallows for shortening fallow cycles in southern Cameroon <i>Christian Nolte, Bernard Ondo Zo'o and Jean Paul Dondjang</i>	921
89. Policies, Institutions and Market Development to Accelerate Technological Change in the Semiarid Zones of Sub-Saharan Africa <i>Mark Winslow, Barry Shapiro and John Sanders</i>	933
90. Factors Influencing Choice and Adoption of Integrated Soil Fertility Management Technologies in Central Kenya Highlands <i>Mureithi B.M., Kimani S.K., Odera M.M., Mwangi E.M. and Gachanja E.</i>	941
91. Social capital and adoption of soil fertility management technologies in Tororo district, Uganda <i>Lule Ali, N. M. Mangheni, P. C. Sanginga, R.J. Delve, F. Mastiko and R. Miuro</i>	947
92. Adoption of Leguminous Trees/Shrubs, Compost and Farmyard Manure (FYM) As Alternatives to Improving Soil Fertility in Trans Nzoia District-Kenya <i>Nekesa. A.O., Okalebo, J.R. and Kimetto, S.</i>	955
93. Participatory Diagnosis in the Eastern Drylands of Kenya: Are Farmers aware of their Soil Fertility Status? <i>Kimiti J.M., Esilaba A.O., Vanlauwe B. and Bationo A.</i>	961
94. On-Farm Evaluation and Scaling-up of Soil Fertility Management Technologies in Western Kenya <i>Odendo, M., Ojiem, J., Bationo, A. and Mudeheri, M.</i>	969
95. The Resources-to-Consumption System: A Framework for Linking Soil Fertility Management Innovations to Market Opportunities <i>Sanginga Pascal C.; Susan Kaaria, Robert Muzira, Robert Delve, Bernard Vanlauwe, Jonas and Nteranya Sanginga</i>	979
96. Scaling Up Options on Integrated Soil Fertility management in Western Kenya: The Case of COSOFAP: Challenges and Opportunities <i>Qureish Noordin, John Mukalama, Daniel Rotich, Electine Wabwile and John Lynam</i>	993
97. Socio-Economics of Soil Conservation in Kericho District, Kenya <i>Kipsat M.J.</i>	1001
98. Market Integration and Conduct Analysis: An Application to Cattle Markets in Uasin Gishu District, Kenya <i>Serem A.K, Maritim H.K, Kipsat M., Kisinyo P. and Nyangweso P.</i>	1013
99. Factors determining integrated soil fertility management in central Kenya highlands: Participatory Learning and Action (PLAR) model analysis <i>Odera M.M., Kimani S.K., Esilaba A.O., Kaiyare J.M., Mwangi E. and Gachanja E.</i>	1019
100. Spatial Pricing Efficiency and Regional Market Integration of Cross-Border Bean (<i>Phaseolus Vulgaris L.</i>) Marketing in East Africa: The Case of Western Kenya and Eastern Uganda <i>L.W. Mauyo, J.R. Okalebo, R.A. Kirkby, R. Buruchara, M. Ugen, and H.K. Maritim</i>	1027

101. Assessment of farmers' perceptions of soil quality indicators within smallholder farms in the central highlands of Kenya 1035
Mairura F.S., Mugendi D.N., Mwanje J.I., Ramisch J.J. and Mbugua P.K.
102. Initiating Rural Farmers to Participatory Research: Case of Soil Fertilization in Bushumba, East of DR. Congo 1047
Paulin Njingulula Mumbeya and Ngongo Mulangwa
103. Farmers' participation in soil fertility management research process: Dilemma in rehabilitating degraded hilltops in Kabale, Uganda 1051
Muzira R.N., Kabale farmers' groups, Pali P., Sanginga P. and Delve R.
104. Integrated Soil Fertility Management and Poverty Traps in Western Kenya 1061
J.K. Ndufa, G. Cadisch, C. Poulton, Q. Noordin and B. Vanlauwe
105. Moving methodologies to enhance agricultural productivity of rice-based lowland systems in sub-Saharan Africa 1077
M.C.S. Wopereis and T. Defoer

Preface

Lack of access to food and its availability is of central concern in Africa and a fundamental challenge for human welfare and economic growth. Low agricultural production results in low incomes, poor nutrition, vulnerability to risks and lack of empowerment. The New Partnership for Africa's Development (NEPAD) targets an average annual increase of 6% in agricultural productivity to ensure food security and sustained national economies. Land degradation and soil fertility or nutrient depletion are considered as the major threats to food security and natural resource conservation in SubSaharan Africa (SSA).

What is needed is to break the cycle between poverty and land degradation in Africa by employing strategies that empower farmers economically and promote sustainable agricultural intensification using efficient, effective and affordable agricultural technologies. Such affordable management systems should be accessible to the poor, small-scale producers and the approach should be holistic and dynamic in order to foster both technical and institutional change. Farmers' and local entrepreneurs' capacities to invest in sustainable land management need to be enhanced by moving farmers in a market-oriented agriculture.

Mineral fertilizers are the most efficient way to reverse soil nutrient depletion (Africa losses \$ 4 billion per year due to soil nutrient mining), and thus improved livelihoods. Whereas in the developed world, overuse of fertilizer and manure has damaged the environment, in SSA the low and insufficient use of fertilizer and other organic amendments has led to overexploitation of soil nutrient resources (nutrient mining) causing environmental degradation.

The Tropical Soil Biology and Fertility (TSBF) Institute of CIAT is a research programme whose main aim is to contribute to human welfare and environmental conservation in the tropics by developing adoptable and suitable soil management practices that integrate the biological, chemical and socioeconomic processes that regulate soil fertility and optimize the use of organic and inorganic resources available to the land users. The African Network for Soil Biology and Fertility (AfNet), being a network of scientists in Africa, is the single most important implementing agency of TSBF in Africa. AfNet's main goal is to strengthen and sustain stakeholder capacity to generate, share and apply soil fertility management knowledge and skills to contribute to the welfare of farming communities. AfNet thus facilitates and promotes collaboration in research and development among scientist in Africa for the purpose of developing innovative and practicable resource management practices for sustainable food production in the African continent. The AfNet members share TSBF goals and approaches. TSBF conducts research in tropical countries, but always in collaboration with national scientists.

AfNet conducts its research agenda through the new paradigm of Integrated Soil Fertility Management (ISFM), a holistic approach to soil fertility research that embraces the full range of driving factors and consequences of soil degradation – biological, chemical, physical, social, economic, and political. Within the more than 80 sites of network trials in different agro-ecological zones distributed in the East, South, Central and West Africa regions, increasingly emphasis is placed on both basic and adaptive research. AfNet has increased its efforts in scaling up results of best bet soil fertility management technologies to more farmers and communities employing a wide range of dissemination tools. The network is also very much involved in training, capacity building and information dissemination activities.

With a total membership of 10 researchers in 1989, AfNet has a total membership of over 350 persons in 2005. It is an African-wide network with 180 members from East and Central Africa, 80 from Southern Africa and 90 from West Africa. AfNet membership is drawn from National Agricultural Research and Extension Services (NARES), international agriculture research centers, universities and individuals from various disciplines mainly soil science, social science, agronomy and technology exchange. AfNet is managed by a scientific committee of African Scientist.

In an effort to achieve its objective of collaborative research, AfNet organizes biannual meetings where network members are offered the opportunity to participate, share, exchange and publish results emanating from their research activities in soil biology and fertility. In May 2004, AfNet organised a symposium in Yaoundé, Cameroon that brought together over 150 participants.

The objectives of the symposium were:

1. To review recent research achievements on integrated soil fertility management (ISFM) and ecosystem services
2. To develop strategies on scaling-up soil fertility enhancing technologies
3. To increase stakeholder awareness of new initiatives in natural resource management including integrated agricultural research for development (IAR4D)

The symposium was organized under three major themes, namely:

1. State of the art on integrated soil fertility management and ecosystem services
2. Opportunities and challenges for scaling up/out integrated soil fertility management innovations
3. Increasing stakeholder awareness of new initiatives in natural resource management and developing strategies for implementation

This book presents papers of the symposium and is divided into four major parts: Part I: Setting the scene: The papers under this section give a general overview of soil fertility management issues in Africa. Part II: Integrated Nutrient Management (INM) presents information on the state of land degradation in Africa, INM approaches and principles, recent achievements on INM technologies and management of carbon and nutrient cycles. Part III: Belowground biodiversity presents information on managing soils for enhanced ecosystem services and managing soil genetic resources for enhanced biodiversity. Part IV: Participatory approaches and scaling up/out, presents information on success stories on development and adoption of sustainable land management, constraints to adoption of ISFM technologies, socio-economics and policy, key concepts of farmer participatory approaches and scaling up/out, opportunities and challenges of participatory market analysis for enabling rural innovations, Integrating ISFM in IAR4D to include market access, enabling policies and their interactions and gender analysis.

The book presents experiences learnt by the various researchers in their effort to achieve sustainable food production and natural resource utilization. It is hoped that the wealth of information the book contains will contribute positively to the design and implementation of future research and development programmes that will lead to sustainable food production and poverty eradication in Africa.

We thank the donor agencies – the Canadian International Development Agency (CIDA), The Rockefeller Foundation, The Ford Foundation, The Syngenta Foundation, The Forum for Agricultural Research in Africa (FARA), the International Foundation for Science (IFS) and the Technical Centre for Agricultural and Rural Cooperation (CTA) – for their intellectual, moral and financial support towards this conference. We also thank the ICRAF office at Yaoundé, Cameroon for helping in the organizing of this symposium.

Joachim Voss
Director General of CIAT

A critical analysis of challenges and opportunities for soil fertility restoration in Sudano-Sahelian West Africa

E. Schlecht¹, A. Buerkert^{2,*}, E. Tielkes³ and A. Bationo⁴

¹Institute for Animal Production in the Tropics and Subtropics, University of Hohenheim, Stuttgart, Germany; ²Institute of Crop Science, University of Kassel, Witzenhausen, Germany; ³Centre for Agriculture in the Tropics and Subtropics, University of Hohenheim, Stuttgart, Germany; ⁴Tropical Soil Biology and Fertility (TSBF) Institute of CIAT, c/o ICRAF, Nairobi, Kenya; *Author for correspondence (e-mail: buerkert@uni-kassel.de)

Key words: Fertilizers, Legumes, Modelling, Organic amendments, Soil fertility management, West Africa

Abstract

Since the 1970s, research throughout West Africa showed that low soil organic matter and limited availability of plant nutrients, in particular phosphorus and nitrogen, are major bottlenecks to agricultural productivity, which is further hampered by substantial topsoil losses through wind and water erosion. A few widely recognized publications pointing to massive nutrient mining of the existing crop–livestock production systems triggered numerous studies on a wide array of management strategies and policies suited to improve soil fertility. Throughout Sudano-Sahelian West Africa, the application of crop residue mulch, animal manure, rockphosphates and soluble mineral fertilizers have been shown to enhance crop yields, whereby yield increases varied with the agro-ecological setting and the rates of amendments applied. In more humid areas of Western Africa, the intercropping of cereals with herbaceous or ligneous leguminous species, the installation of fodder banks for increased livestock and manure production, and composting of organic material also proved beneficial to crop production. However, there is evidence that the low adoption of improved management strategies and the lack of long-term investments in soil fertility can be ascribed to low product prices for agricultural commodities, immediate cash needs, risk aversion and labour shortage of small-scale farmers across the region. The wealth of knowledge gathered during several decades of on-station and on-farm experimentation calls for an integration of these data into a database to serve as input variables for models geared towards *ex-ante* assessment of the suitability of technologies and policies at the scale of farms, communities and regions. Several modelling approaches exist that can be exploited in this sense. Yet, they have to be improved in their ability to account for agro-ecological and socio-economic differences at various geographical scales and for residual effects of management options, thereby allowing scenario analysis and guiding further fundamental and participatory research, extension and political counselling.

Soil fertility – the perpetual issue

Owing greatly to the two major Sahelian droughts in the early 1970s and 1980s, the poor productivity

of agropastoral systems in Sudano-Sahelian West Africa (SSWA) has raised worldwide concern and subsequently stimulated numerous research and development projects dealing with issues of soil

This article has been previously published in the journal “Nutrient Cycling in Agroecosystems” Volume 76 Issues 2–3.

fertility, land degradation and desertification (Schlecht and Hiernaux 2004). For the West African Sahel in particular, Dutch scientists demonstrated that above an average annual precipitation of 250 mm, low soil organic matter (SOM) and limited availability of plant nutrients, in particular phosphorus (P) and nitrogen (N), are major bottlenecks to plant production (Penning de Vries and Djitéye 1982; Breman and De Wit 1983).

Even if one has to be careful to generalize across SSWA given the widespread occurrence of erosion-related micro-habitats (such as depressions with clay and nutrient accumulations), there is evidence of a clear eco-regional gradient in the physico-chemical factors that limit plant growth. While at an average annual rainfall < 300 mm and soil pH values between 5.5–6.5 water availability is most limiting, from 300 to 600 mm of rainfall and soil pH from 4.1 to 4.5, low P and N availability are primarily hampering biomass production. Finally, at < 600 mm annual precipitation and soil pH > 4.5, N, sulphur (S) and potassium (K) deficiencies prevail. Across the same rainfall gradient, the soils' texture successively increases in clay content from below 5% to more than 15% (Buerkert et al. 2000).

Another issue of major concern throughout the Sahelian and Sudanian zones¹ were the topsoil loss and redistribution processes caused by wind and water erosion and their effects on the soils' nutrient status and productivity. Both topics received new momentum in the early 1990s with a series of widely discussed nutrient budget assessments pointing to massive nutrient mining of the existing crop–livestock production systems (Stoorvogel and Smaling 1990; Van der Pol 1992; Krogh 1997). The controversial discussion about the validity of these budgets at different scales triggered a new series of studies on nutrient and natural resource management strategies and policies which aimed at improving soil fertility and consequently crop and livestock performance in SSWA (Bationo et al. 1998). Erosion control by mulch application or ridging, a better integration of livestock and crop production and targeted use of organic amendments were all seen as prerequisites to maintain

soil fertility (McIntire et al. 1992; Powell and Unger 1998). Despite controversy about the necessary technical and political approaches, there was widespread consensus that any increase in the region's agricultural production level would require substantial inputs of mineral fertilizers (Van Keulen and Breman 1990; Buerkert and Hiernaux 1998; Breman et al. 2001).

Concurrently with these more fundamental studies, a considerable number of technologies were generated to improve the productivity of African soils, but farmers have not or only partly implemented many of these (Bationo et al. 1998; Haigis 2004). Increasingly, social scientists, economists and agronomists started to acknowledge the efficiency of farmers' low external input strategies to maintain the productivity of selected parts of their fields (Brouwer et al. 1993; Lamers and Feil 1995; Lamers et al. 1995; Sterk and Haigis 1998), and provided contrasting evidence to previous predictions of imminent doomsday-scenarios (Scoones and Toulmin 1998; Mazzucato and Niemeijer 2001; De Ridder et al. 2004).

The existence of such gaps between scientific findings and farmers' reality, however, only partly explains the low adoption rates observed for recommendations to enhance the soil productivity of farmers' fields. Aiming at conclusions about how to better match our present knowledge with farmers' short- and long-term needs of increased productivity, the achievements and shortcomings of relevant studies on soil fertility maintenance in the crop–livestock systems of SSWA were critically reviewed. Hereby, the analysis concentrated on the comparability of results of similar studies across locations and climatic gradients, and the quantification of possible residual effects of technologies on soil fertility and productivity. Particular emphasis was put on the understanding of the physical and social buffering capacity of the land use systems under study. It was also evaluated whether the studies accounted for the requirement and availability of amendments, labour and capital needed for specific technologies at the farmers' level. In addition, the usefulness of existing bio-economic and land use models for *ex-ante* analysis of the biophysical and socio-economic benefits of technologies from the plot to the regional scale was examined.

¹In the present context, the term Sahelian zone is used synonymously for the semi-arid zone (average rainfall 250–600 mm a⁻¹) and the term Sudanian zone for the sub-humid zone (600–900 mm a⁻¹).

Restoring soil fertility: the multitude of technical solutions

It is a commonly accepted paradigm that above an average annual rainfall of 250 mm, the low soil productivity in rainfed agriculture of SSWA is due to a combination of unfavourable factors. These comprise a very poor chemical and physical status of the highly weathered and predominantly acid sandy soils (low P and N reserves and plant availability, low SOM, low pH, low water holding capacity, rapid crust formation), erratic rainfall, the effects of abrasive storms and the occurrence of insect pests and low prices for the produced commodities. The latter hamper subsistence-oriented farmers' investments in measures to enhance soil fertility, thereby providing a widespread impression of 'soil mining' (Van Keulen and Breman 1990; Breman et al. 2001).

Technical approaches to overcome low soil productivity include (i) mulching with crop residues, (ii) hand-spreading of household wastes, animal manure and compost, (iii) corralling of livestock on fields, (iv) intercropping or rotation of cereals with legumes and (v) application of rock-phosphates and soluble N and P fertilizers. Hereby, the proportion of yield increase varies with the agro-ecological setting (soil types and rainfall) and the rates and frequencies of applying these amendments.

In traditional land use systems, declining SOM and nutrient status of continuously cropped land was regularly restored by observing several years of fallow. Fallowing improves the soil nutrient status through the capture of mineral-rich soil particles (in particular of K and Ca) eroded by wind near the fallow or in distant source areas (Herrmann 1996; Sterk et al. 1996; Rajot 2001; Wezel and Haigis 2002). Mineralisation of fallow shoot and root biomass increases SOM, and fallow legumes may help to raise soil N by symbiotic N₂-fixation. Despite these well-known effects of fallowing on the soil fertility status, rapid population growth leading to shortage of suitable cropland prevents the continued widespread use of this practice throughout the region (Graef 1999; Wezel and Haigis 2002; Schlecht and Buerkert 2004). Another technology with little practical relevance for large parts of the drier areas of Sahelian West Africa is that of planted windbreaks. Although the latter are often assumed to

have positive effects on plant establishment, SOM and nutrient availability, experimental data on the competition for water and nutrients and their effects on biomass production are scarce (Leihner et al. 1993; Brenner et al. 1995; Smith et al. 1997; Michels et al. 1998). Even though successful in reducing erosion (Michels et al. 1998), the installation and effective management of such windbreaks requires high capital and labour inputs that can only be provided by external subsidies such as development projects or government programs (Lamers et al. 1996). In addition, a more widespread use of windbreaks can create land tenure problems (Neef 1999). Breman and Kessler (1997) have summarized that windbreaks seem helpful to improve crop establishment on sandy soils (particularly in the southern Sahelian zone) at specific locations with a shallow ground water table, where competition for moisture with annual crops is avoided. In the Sudanian zone, however, maximum benefits for crop production are obtained where the canopy cover is 15–20%, trees are homogeneously distributed and have a high ratio of trunk height to crown diameter (achieved by pruning). The impact of agroforestry practices seems particularly important on slopes and in the upper part of watersheds given their positive effects on soil stabilisation, and at desert margins for the protection of productive land from wind erosion (Breman and Kessler 1997).

Soil tillage has also been advocated to foster crop growth by enhancing soil porosity and aeration, infiltration rate, water holding capacity and nutrient mineralisation from organic material. With yield increases of 22–103%, these benefits were particularly evident in the Sudanian zone (Nicou and Charreau 1985). In the Sahelian zone, Klaij and Hoogmoed (1989) observed improved establishment, seedling survival and early growth of pearl millet (*Pennisetum glaucum* L. R. Br.) due to reduced wind erosion after ridging, and Subbarao et al. (2000) reported an 11-year average grain yield increase of 83% with ridging for the same crop. Across zones, benefits of soil tillage certainly depend on the soil type, but the labour investment involved may only be profitable with higher-valued crops such as cotton (*Gossypium hirsutum* L.) or paddy rice (*Oryza* spp.; Jansen 1993). At the farm level an important constraint to tillage on Sahelian soils is the increased draught power needed for ploughing the

bone-dry soils at the onset of the rainy season, a time when draught animals are often ill-fed and therefore weak. Due to their locally limited relevance in the West African context, the aforementioned three technologies will not be considered further in this analysis.

Effects of organic amendments on soil quality and crop yields

The clay fraction of most Sahelian and Sudanian soils is characterized by low sorption minerals dominated by kaolinite and therefore the SOM concentration largely determines the total cation-exchange capacity, pH and aluminium toxicity of these soils (Bationo and Buerkert 2001). However, given the synchrony between high soil temperatures and rainfall as well as termite activity throughout the Sudano-Sudanian zone, native or added SOM is rapidly mineralised under land cultivation, even in the drier areas. On most soils medium- and long-term SOM therefore remains low, even if elevated amounts of plant biomass are recycled during fallow periods or with mulching and manuring (Feller and Milleville 1977; De Ridder and Van Keulen 1990; Renard et al. 1993; Bacyé et al. 1998).

Buerkert et al. (2000, 2002) have summarized how short-term effects of mulch application on soil physical and soil chemical properties and finally on crop growth depend in magnitude on the specific soil type (such as its clay content) and the climatic conditions (intensity and length of the rainy season). Mulching effects certainly also depend on the kind of organic material applied (branches of woody species, crop residues such as stover, household waste, compost and hand-spread manure) even if to our knowledge comparative data on the effects of different mulch materials have not been published.

Mulching of crop residues and other plant material

Mulching, that is the superficial application of plant material, is most commonly done with residues of cereal crops, such as millet, sorghum or maize stover. For the Sahelian zone reported physical effects of annual application rates of 2000 kg ha⁻¹ (typically used in researchers' experiments but rarely available on farmers' fields)

comprise the following: reduced wind and water erosion effects on seedling emergence and early growth (Michels et al. 1995a, b), breakage of surface crusts and a decrease in soil surface penetration resistance (Hoogmoed and Stroosnijder 1984; Buerkert and Stern 1995) by a stimulation of termite activity, higher root length density (Hafner et al. 1993), increased formation of stable soil aggregates enhancing soil porosity and water infiltration, higher water holding capacity and a decreased maximum soil surface temperature (Buerkert and Lamers 1999; Figure 1). Through carbon addition and/or a decelerated decomposition of native SOM, mulching can also lead to relative increases in SOM levels and an increase in pH compared to unmulched control plots (Bationo and Buerkert 2001). On sandy soils, mulching has been reported to cause significant changes in soil chemistry such as increases of cation exchange capacity (CEC), P availability through decomplexation of P from Al and Fe chelates through ligand exchange mediated by organic acids (Kretzschmar et al. 1991). Also important are pH and K increases through residue mineralisation or capturing of Harmattan transported dust (Herrmann et al. 1993; Rebafka et al. 1994; Buerkert and Lamers 1999; Sinaj et al. 2001). An experiment conducted by Buerkert and Lamers (1999) allowed to differentiate between the physical and chemical components of mulch-induced effects on millet growth. Mulched application of millet stover at 2000 kg ha⁻¹ decreased eolian losses of topsoil to a similar extent as an equivalent soil cover of 10% with inert polyethylene tubes. In three subsequent years, total dry matter (TDM) increase of millet above the bare control was 35, 108 and 283% when stover was applied but only 6, 44 and 13% with plastic mulch. These differences reflected the plant-nutritional components of residue mulch effects. Yield increases due to mulching obtained in other studies throughout the region are summarised in Table 1.

Wezel and Boecker (1999) measured that a single mulching with twigs of *Guiera senegalensis* J. F. Gmel. at 1000 and 2000 kg ha⁻¹ can lead to average millet grain yield increases of 68 and 83% over 2 years. Given the widespread growth of *Guiera* on farmers' fields, these authors concluded that regular applications of 1000 kg ha⁻¹ of its branches at least on low-productivity parts of fields could substantially increase millet production.

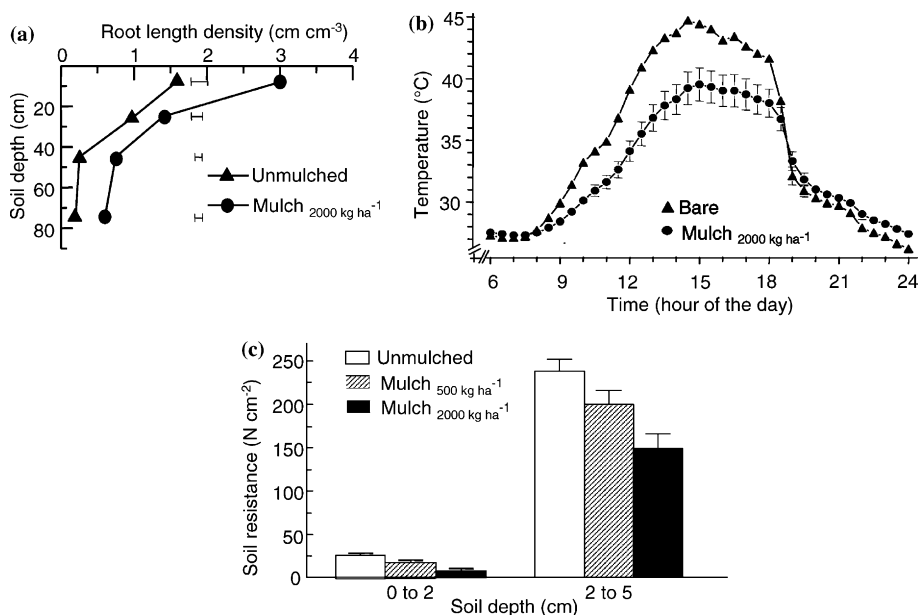

Figure 1. Effects of different amounts of crop residue mulch on millet root length density (a; Hafner 1993; horizontal bars show one LSD_{0.05}), soil temperature and soil resistance (b and c; Buerkert and Lamers, 1999; vertical bars show standard errors of the mean) on acid sandy soils of south-western Niger.

Table 1. Effects of different application frequencies and amounts of cereal crop residues on cereal grain yields in different agro-ecological zones of Sudano-Sahelian West Africa as reported by different authors.

Amendment	Amount (kg ha ⁻¹)	Grain yield increase above control	Application frequency	Zone, soil type	References
Millet crop residues	2000	Millet: 20–>100%	Annually	Semi-arid (Burkina Faso), Arenosol	Bationo et al. (1992, 1993, 1995)
Millet crop residues	2000 (control = 500)	Millet: 1st year 6%, 2nd year 20%, 3rd year 32–40%	Annually	Semi-arid (Niger), Arenosol	Buerkert et al. (2000, 2002)
Millet crop residues	4000	Millet: 250%	Annually	Semi-arid (Niger), Arenosol	Bationo and Mokwunye (1991)
Millet crop residues + fertilizer	4000 + 13 kg P ha ⁻¹ broadcast	Millet: 790%	Annually	Semi-arid (Niger), Arenosol	Bationo and Mokwunye (1991)
Millet crop residues	2000	Millet: 1st year 20%, 2nd year 108%, 3rd year 283%	Annually	Semi-arid (Niger), Arenosol	Buerkert and Lamers (1999)
Millet crop residues	All CR from last harvest	Millet: 40–238%	Annually	Semi-arid (Niger), Arenosol	Yamoah et al. (2002)
Millet crop residues + fertilizer	All CR from last harvest + 13 kg P ha ⁻¹ + 30 kg N ha ⁻¹ broadcast	Millet: 90–>400%	Annually	Semi-arid (Niger), Arenosol	Yamoah et al. (2002)
Maize straw	Not clarified	Soybean: 21%	Annually	Semi-arid (Senegal), Arenosol	Dommergues and Ganry (1986)
		Maize: 44%			

Several other authors have reported mulching with various grasses, leaves and small branches collected from fallow vegetation, bushes and trees to be a common practise of farmers in different regions of SSWA (Lamers and Feil 1995; Slingerland and Masdewel 1996; Hien et al. 1998). However, it appears as if the reasons why these practises so far have attracted little research attention are the heterogeneity and the scarcity of the available mulch material as well as the large amount of labour needed for its collection and transportation (Slingerland and Masdewel 1996).

Manuring, corralling and compost application

Due to limited access to mineral fertilizers, manure from livestock is an important source of SOM and nutrients for crop production throughout SSWA, even if its availability in sufficient quantity may be a major constraint at many places (Powell et al. 1998). In the West African context, manure availability, quality, storage and application, therefore, has received much scientific attention (Williams et al. 1995; Fernández-Rivera et al. 1995; Harris 2002; Schlecht et al. 2004). In the predominantly extensive West African production systems, livestock graze the vegetation of natural pastures and fallows year-round, whereas cereal stover and weeds on fields are grazed only after grain harvest until the start of the new cropping season. Although varying with the grazing regime, close to 50% of the daily (24 h) amount of faeces and urine are excreted during the night rest period and in the early morning when animals get up (Schlecht et al. 1995, 1998). If the night resting place is at a fixed location, the dry manure and bedding material, feed leftovers and other organic compound waste or ash can be easily collected and transported to the field. This so-called farmyard manure varies greatly in quantity and quality, depending, among others, on the organic material included besides the faeces (De Jager et al. 1998; Harris 1998; Hoffmann et al. 2001; Harris 2002). Early work by Bationo and Mkwunye (1991) reported four-fold increases in millet grain yields after the application of 20 t ha⁻¹ of dry farmyard manure. A particular way of targeted application of farmyard manure is the *zaï* technique, which consists in digging small planting holes and filling them with manure before the crop is sown into the hole. The advantages of this

technique consist in the simultaneous increase of manure derived SOM, mineralised nutrients and collected rainfall in the immediate rooting environment of crops (Fatondji 2002).

However, if no bedding material is used at the animals' resting place, the nutrients from urine are percolating into the soil and cannot be recovered (Powell et al. 1998). To concentrate manure on a field scheduled for cultivation, livestock can also be corralled or tethered there overnight. In this way, no labour is required for manure handling, and urine is applied to the soil along with the faeces, supplying supplementary N and instantaneously increasing the pH of the wetted topsoil by up to 4 units, whereby sheep urine appeared to be more effective than urine from cattle (Brouwer and Powell 1998; Ikpe et al. 1999). Measurements of diurnal and seasonal variations in urine pH of cattle, sheep and goats grazing Sahelian pasture revealed that at least in the evening, the urine of sheep was mostly lower in pH than the urine of cattle and goats (Table 2). Although monthly differences in species-specific urine pH were at maximum 0.47 units, the variation between minimum and maximum diurnal values determined within a species reached up to 3.55 pH units. However, the reported increase in soil pH due to urine application is not primarily linked to urine pH as such but to the release of hydroxide anions during urea hydrolysis (Powell et al. 1998), which implies that changes in soil pH mainly depend on the urea content of the urine. Although N-containing by-products of the metabolism of proteins and nucleic acids are also excreted in urine, urea accounts for approximately two-thirds of urine N (Bristow et al. 1992). The N excretion via urine thereby depends on the dietary supply of soluble and non-soluble proteins and intake of salt and water. Per kilogram live weight, daily urine-N excretion in cattle, goats and sheep fed with dry and green Sahelian roughages was determined at 50–420, 84–460 and 72–600 mg, respectively (Schlecht 1995; Schlecht et al. 1998), from which the efficiency of urine to increase soil pH can be deduced.

For faeces, reported nutrient concentrations per kilogram of dry matter vary between 9 and 25 g N, 0.09 and 2.7 g P, and 2.5 and 37 g K (Williams et al. 1995). Outside of corrals, an average yearly rate of return to village cropland, pastures and fallows through faeces of 0.09–0.23 kg P ha⁻¹ was estimated from grazing and

Table 2. Diurnal and seasonal variations in the pH of urine voided by cattle, sheep and goats grazing Sahelian pasture (Schlecht unpublished data).

Period ^a	January (mid-dry season)			March (late dry season)			June (early rainy season)			August (mid-rainy season)			October (post-harvest season)			December (early dry season)		
	Cattle	Goats	Sheep	Cattle	Goats	Sheep	Cattle	Goats	Sheep	Cattle	Goats	Sheep	Cattle	Goats	Sheep	Cattle	Goats	Sheep
Morning	Mean ^b	8.22	8.32	8.18 ^b	8.27 ^z	8.25 ^z	8.42 ^{αβ}	8.31 ^a	8.37 ^a	8.12	8.13 ^b	8.22	8.32	8.18 ^b	8.20 ^x	8.36 ^{αβ}	8.35 ^β	
	SD	0.14	0.39	0.15	0.07	0.10	0.16	0.12	0.15	0.11	0.26	0.18	0.39	0.15	0.14	0.12	0.06	
Noon	N	12	4	11	8	10	11	9	7	12	12	12	4	11	9	10	6	
	Mean	8.01 ^b	7.35 ^b	8.29 ^a	8.13	8.13	8.23 ^a	8.22	8.35 ^{αz}	8.17 ^{αβ}	7.60 ^b	8.01 ^b	7.35 ^b	8.10	8.23 ^a	8.10	8.23 ^a	
Afternoon	SD	0.18	0.06	1.26	0.13	0.14	0.04	0.03	0.17	0.14	0.62	0.06	0.06	1.26	0.09	0.14	0.08	
	N	8	2	2	6	11	2	7	5	17	10	8	2	2	7	6	7	
	Mean	8.02 ^{bx}	7.34 ^β	8.23 ^{αz}	8.15 ^{αz}	8.15 ^{αz}	7.57 ^β	8.26 ^{αz}	8.25 ^{αz}	8.07 ^{αβ}	7.61 ^c	8.02 ^{bx}	7.34 ^β	8.15 ^a	8.21 ^{αz}	8.09 ^{αβ}		
	SD	0.13	0.18	0.76	0.12	0.16	0.62	0.04	0.15	0.14	0.29	0.13	0.18	0.13	0.13	0.13	0.19	
	N	15	19	18	17	18	13	13	15	16	14	15	19	18	15	15	12	

^aPeriods: morning 6:31–11:00 h; noon 11:01–14:30 h; afternoon 14:31–19:00 h.

^bPresentation of statistical results: A, B indicate differences in pH between periods of the day, within species and months; a, b indicate differences in pH between months, within species and periods of the day; α, β indicate differences in pH between species, within months and periods of the day. Level of significance: $P \leq 0.05$.

excretion behaviour of livestock (Schlecht et al. 2004). Daily excretions of faecal N were in the range of 63–230 mg kg⁻¹ live weight in cattle, 160–210 mg kg⁻¹ in sheep and 140–170 mg kg⁻¹ in goats (Schlecht 1995; Schlecht et al. 1998), whereby seasonal conditions, the ingested diet (green or dry grass) and the presence or absence of secondary plant compounds (especially tannins) have an equally important impact on variations in faecal N-concentrations than the livestock species (Powell et al. 1994, 1999; Somda and Powell 1998; Schlecht et al. 1998).

The effects of different manuring and corraling treatments on crop yields in the region vary widely (Table 3). As for crop residue mulching, underlying causes for the positive effects of manure application are increased soil porosity and aggregate stability, increased water infiltration and water holding capacity, decreased eolian soil losses, increased SOM, pH, CEC and nutrient availability (Powell et al. 1996, 1998, 1999).

Similar to other organic amendments, the application of compost has been reported to increase soil pH, CEC and P and N availability on poorly buffered soils of SSWA. In the sub-humid zone of Burkina Faso, surface application of compost at 5 t ha⁻¹ led to grain and straw yield increases of *Sorghum* (*Sorghum bicolor* L. Moench) of 46–69% and 16–20%, respectively, above the unamended control in the year of application (Ouedraogo et al. 2001). Similarly, Dommergues and Ganry (1986) reported yield increases of 13 and 54% above the control in soybean (*Glycine max* L. Merr.) and maize (*Zea mays* L.) grain, respectively, when applying 1.5–2 t ha⁻¹ of compost. While being very effective in increasing yields, compost preparation requires the availability of substantial amounts of unused organic material, labour inputs for the establishment of a suitable pit, and regular watering and turning. Therefore this technology is likely to be of major practical importance only where farmers are better-off or receive external support, where livestock are managed in zero-grazing systems and all manure is deposited at the homestead, and in peri-urban or wetter areas with higher biomass availability.

The dependency of manuring and composting techniques on the availability of significant amounts of biomass (as feed or compostable matter) is also reflected by the fact that these

Table 3. Effects of different application frequencies and amounts of farmyard manure, single superphosphate (SSP) and compost on cereal grain yields in different agro-ecological zones of Sudano-Sahelian West Africa as reported by different authors.

Amendment	Amount (kg ha ⁻¹)	Grain yield increase above control	Application frequency	Zone, soil type	References
Farmyard manure ^a	5000	Millet: 99%	Once every 3 years	Semi-arid (Burkina Faso), Arenosol	Bationo and Mokwunye (1991)
Farmyard manure ^a + SSP	5000 + 8.7 broadcast	Millet: 202%	Once every 3 years/SSP yearly	Semi-arid (Burkina Faso), Arenosol	Bationo and Mokwunye (1991)
Farmyard manure ^a + rockphosphate	5000 + 39.3 broadcast	Millet: 163%	Once every 3 years/RP yearly	Semi-arid (Burkina Faso), Arenosol	Bationo and Mokwunye (1991)
Farmyard manure ^a	20,000	Millet: 302%	Once every 3 years	Semi-arid (Burkina Faso), Arenosol	Bationo and Mokwunye (1991)
Farmyard manure ^a + NPK fertilizer	5000 + 100 broadcast	Millet: 150–700 kg ha ⁻¹	Yearly	Semi-arid (Burkina Faso), Arenosol	Dugué (1998)
Manure corralled	2000	Millet: 1st year 350 kg ha ⁻¹ , 2nd year 90 kg ha ⁻¹ , 3rd year 190 kg ha ⁻¹ , 4th year 145 kg ha ⁻¹	Once every 5 years	Semi-arid (Niger), Arenosol	Schlecht et al. (2004)
Manure corralled	4000	Millet: 1st year 500 kg ha ⁻¹ , 2nd year 177 kg ha ⁻¹ , 3rd year 240 kg ha ⁻¹ , 4th year 150 kg ha ⁻¹	Once every 5 years	Semi-arid (Niger), Arenosol	Schlecht et al. (2004)
Compost ^b	5000	Sorghum: 46%	1-year experiment	Semi-arid (Burkina Faso), Ferric Lixisol	Ouedraogo et al. (2001)
Compost	1500–2000	Soybean: 12% Maize: 54% Sorghum: 45%	Yearly	Semi-arid (Senegal), Arenosol	Dommergues and Ganry (1986)

^aManure contained 0.41% total P and 1.21% total N.

^bCompost from selected household refuses, animal manure, crop residues and ashes; during a second decomposing step, grasses were added to increase the availability of carbon as an energy source; average C:N ratio of the compost was 12 at a C_{org} content of 160 g kg⁻¹ and a pH of 7.

methods of soil fertility restoration are applied more frequently in the humid zones of the West African Sahel: in a village in Western Niger receiving 360 mm a⁻¹ of rain, corralling and farmyard manure application together were practiced on 25% of farmers' fields (Schlecht and Buerkert 2004) compared to 34% in a village in Burkina Faso receiving 800 mm a⁻¹ of rain (Mertz and Reenberg 1999). In any case, due to the scarcity or alternative uses of amendments as well as on-farm labour, such practices often cover only a few smaller fields of a household or parts of an individual field (Schlecht and Buerkert 2004), and will thus not allow to enhance soil productivity at a larger scale.

Association of cereals with legumes

The beneficial effects of legume cultivation for soil fertility are well known and can be ascribed to improved soil physical properties, N₂-fixation, enhanced P-availability through secretion of enzymes or acids in the legume rhizosphere (Bagayoko et al. 2000b) to which phytosanitary components may add.

For groundnut (*Arachis hypogaea* L.) and cowpea (*Vigna unguiculata* L. Walp.) receiving approximately 800 mm a⁻¹ of rainfall in the Sudanian zone of West Africa, N₂-fixation was estimated at 0.6 and 1.7 g N per plant, respectively, equivalent to 1.2 and 1.5% of total N in the harvested biomass (Harris 1998). Intercropping of cowpea with millet may enhance millet grain yields by 30% above the control (Bationo et al. 1995). Rotations of legumes with cereals can lead to even larger yield increases of cereals on West African soils which are, however, strongly dependent upon choice of the legume species and site conditions. Multi-year trials showed groundnut-induced increases in TDM yield of maize and sorghum by 83% at 1300 mm a⁻¹ average rainfall, whereas the use of cowpea in the drier Sahelian zone did not lead to substantial yield differences in rotation cropping compared to continuous cropping of cereals (Buerkert et al. 2002). In their evaluation of traditional cropping systems in Africa, Dakora and Keya (1997) concluded that legume-cereal rotations were by far more sustainable than intercropping systems. Without providing details on growing conditions or soil type they reported

a doubling of maize yields after groundnut or cowpea compared to continuous maize and maize-legume intercropping. Process-oriented research revealed that legume-induced increases in cereal yields were due to higher early season N availability, enhanced infection of cereal roots with arbuscular mycorrhiza, decreased nematode infestation, increased soil pH, improved P availability through changes in soil chemistry and enhanced phosphatase release (Bagayoko et al. 2000a-c; Alvey et al. 2001, 2003; Marschner et al. 2004). Changes were also observed in the bacterial community structure whose effects, however, are still poorly understood.

Despite experimental evidence of large positive legume effects on cereal growth in crop rotations and the conclusion of Bationo and Ntare (2000) that a legume-millet rotation in combination with 30 kg N ha⁻¹ to millet appears to be a viable option for millet production throughout semi-arid West Africa, only very few farmers in sub-Saharan West Africa currently practise legume rotations. The large majority of them grow either pure cereal stands or cereals with loosely interplanted legumes, the latter being introduced as a relay crop filling in for missing planting hills (Mertz and Reenberg 1999; Schlecht and Buerkert 2004). Some of farmers' apparent dislike of pure legume stands in rotations might come from the perceived risk of insect and disease attack of legumes when grown on a comparatively large surface whose prevention would require regular spraying of insecticides. Another cause may be the low storability of legume seeds (particularly in cowpea) due to post-harvest attacks of seed borers which, under farmers' conditions, require a quick sale of the product at low post-harvest prices. For subsistence farmers cereal-dominated intercropping with a sparse legume component may thus be a typical risk-averting strategy. In terms of total surface area cropped, Mertz and Reenberg (1999) reported deliberate intercropping of cereals and legumes on 85% of the fields in a village of Burkina Faso receiving 800 mm a⁻¹ of rain, whereas sparse relay-type intercropping was observed on 78% of the investigated fields in a Nigerian village receiving 360 mm a⁻¹ of rain (Schlecht and Buerkert 2004).

Thomas and Sumberg (1995) have reviewed data from sub-Saharan Africa on the fertiliser requirements, persistence, management, use and

nutritive value of forage legumes. Besides legume intercropping and rotation, the cultivation of legumes in fodder banks or ley systems can be effective to enhance soil fertility along with livestock nutrition. By modelling four different grazing schemes of a *Stylosanthes hamata* (L. Taub.) ley in the Sudano-Sahelian transition zone, Bosma et al. (1999) predicted an annual increase in SOM by 500–1500 kg ha⁻¹ above the values obtained under the current crop–livestock husbandry system, however, the time horizon of the modelling runs was not disclosed. To maintain high SOM levels, their linear programming approach suggested an intensified use of cereal residues as fodder and embedding material in livestock kraals combined with P-fertilized ley systems, whereby the latter would allow maintaining higher animal densities throughout the dry season. However, as portrayed by Sumberg (2002), intensified forage legume production has not been proven attractive for small-scale farmers, despite clear evidence that their cultivation is possible above 800 mm a⁻¹ of rainfall in all major agro-ecological zones of Africa.

Agroforestry

Even if the methodology used to measure their actual N₂-fixation is not always clear, sub-Saharan tree legumes, comprising also the widely spread *Acacia* species, are reported to be an important component in the sustainability of open parkland, agro-forestry and alley cropping systems. Summarizing studies carried out across sub-Saharan Africa, Dakora and Keya (1997) reported that N addition to maize from pruning of tree twigs and leaves ranged from 200 kg N ha⁻¹ for *Calliandra calothyrsus* Meissn on an N-fertilized Alfisol in Nigeria to 643 kg N ha⁻¹ for *Leucaena leucocephala* Lam. De Wit on an unknown soil type in Kenya. Reported estimates of yearly N₂-fixation ranged from 36 kg N ha⁻¹ for *Acacia holosericea* Cunn. ex G. Don to 581 kg N ha⁻¹ for *Leucaena leucocephala*, whereby the range reported for individual tree species was sometimes as wide as the range for all species analysed in one region (Dakora and Keya 1997). The latter high fixation rates would certainly be uncommon for the drier parts of sub-Saharan West Africa where low soil moisture during the recurrent drought

spells has been reported to reduce nodule functioning in symbiotic legumes through the collapse of lenticels (Pankhurst and Sprent 1975), decreased nitrogenase activity, reduced respiratory capacity of bacteroids and a decline in the leg-haemoglobin content of nodules (Guerin et al. 1990). High temperatures, commonly found throughout this region, can further hamper N₂-fixation (Dakora and Keya 1997). As far as perennial shrubs are concerned, much of the typical open parkland system in the Sahelian zone of West Africa is characterised by irregular but relatively dense *Guiera senegalensis* stands. Wezel and Boecker (1998) and Gérard and Buerkert (1999) have well documented the yield enhancing effect of these shrubs on millet planted in their immediate surroundings and shown that this effect is at least partly due to enhanced N and P availability from leaf fall and dust accumulation.

In contrast, Breman and Kessler (1997) concluded that the integration of woody plant species in West African cropping systems does not necessarily provide benefits to farmers, because added values from trees such as improved soil fertility due to efficient internal nutrient recycling and N₂-fixation are lowest in unfavourable biophysical environments where they are most needed. Often there is a strong competition for light, nutrients and water between woody plants and crops or pastures, or else intensive tree use and droughts prevent an optimal canopy cover and effective contribution of woody species to maintain or raise SOM levels.

There has been considerable debate about the role that hedgerow systems involving a perennial shrub or tree and an annual species planted in-between may play in enhancing crop production throughout SSWA. General claims that annual crop yields could be substantially increased after the mulched application of leaves and twigs cut from legume hedgerows were soon challenged by research results from the Guinean and Sudanian zone. It became evident that woody species in alley cropping systems can indeed contribute to increased N₂-fixation, nutrient recycling, reduced leaching and erosion losses and to a stimulation of soil faunal activity (Kang 1997; Tian et al. 2003), but it remains questionable whether they can also be a remedy against a long-term decline in soil fertility, thereby sustaining crop production without the use of added mineral fertilizers. The

results of studies on root distribution and root density across soil profiles (Akinnesi et al. 1999; Lose et al. 2003) pointed to the strong competition for water and nutrients between annuals and perennials in many agro-forestry systems on the predominantly nutrient-poor soils of SSWA. Although alley cropping with low-competitive tree species such as *Cajanus cajan* L. Millsp. was reported to increase maize yields up to 50% on highly weathered unfertilised Ultisols, greatest monetary benefits were obtained with the application of mineral fertilizers in simple cassava-maize intercropping systems where nutrient cycles were reportedly almost closed (Akondé et al. 1996, 1997). Comparable data from the Sahelian zone is scarce but results from the above-mentioned trials on ligneous windbreaks point to even stronger inter-species competition on acid-sandy Arenosols with large depressions in crop yields near hedgerows (Leihner et al. 1993; Michels et al. 1998).

Mineral fertilizers

There is a wealth of site-specific information about the short-term yield enhancing effects of P, N and molybdenum (Mo) fertilizers on cereals and legumes grown on severely nutrient deficient soils of SSWA (Piéri 1986; Bationo et al. 1986, 1990, 1992, 1993; Friesen 1991; Hafner et al. 1992; Rebafka et al. 1993a, 1994; Buerkert and Hiernaux 1998; Buerkert et al. 2000, 2001, 2002; Muehlig-Versen et al. 2003), some of which are summarized in Table 4. Single superphosphate (SSP) applied annually at 13 kg ha⁻¹ effectively removed P deficiency on most soil types tested throughout SSWA. For groundnut, however, Rebafka et al. (1993b) provided evidence that its S-component can lead to reduced Mo uptake and thus growth reduction compared to a P application as triplesuperphosphate (TSP). On S-deficient soils above 1000 mm a⁻¹ rainfall, however, at the same rate of P applied SSP may be more effective than TSP (Friesen 1991).

Phosphorus-induced yield increases in cereals have been shown to substantially increase with N application. Despite site-specific variation in the relative importance of N and P, experimental evidence from Mali strongly suggests that the relative importance of N compared with P increases with rainfall from north to south across the Sudano-Sahelian zone and that at most sites P is more

limiting for crop growth than N (Poulain et al. 1974). Most of this fertilizer-response research was set up to examine the immediate effects of a single or repeated application of soluble N and P. However, surprisingly little is known about their residual effects on plant growth over time, although such effects seem crucial to predict adoption of P-application technologies by small-scale farmers. Residual effects of mineral P fertilizers were studied only occasionally, but Gérard et al. (2001) reported a 14% increase in the dry matter yield of herbaceous fallow vegetation two years after the last addition of SSP to millet plots on a luvic Arenosol in the Sahelian zone.

Rockphosphate (RP) from different regional sources, RP compacted with soluble fertilizers and partially acidulated phosphate rock (PAPR) have also been tested at a number of sites throughout West Africa and shown to vary widely in their efficiency relative to soluble P (Bationo et al. 1990; Bationo and Mokwunye 1991; Buerkert et al. 2000, 2002). The variation of these effects likely depends on the origin of the rock, site-specific soil properties and rainfall, but these parameters have not yet been systematically incorporated into decision-support systems to define recommendation domains for RP.

On the other hand there is evidence that on weakly buffered West African soils the use of mineral fertilizers may also lead to rapid decreases in SOM and pH, thereby detrimentally affecting crop yields in the long run (Piéri 1986; Bationo and Buerkert 2001). This is in contrast to evidence from chemically more fertile soils in the temperate zones with their much higher buffering capacity. To be sustainable, any long-term application of mineral fertilizers to Sudano-Sahelian soils will therefore need to be combined with the application of organic matter to compensate for the relatively higher SOM turnover rates on fertilized plots.

Moreover, harmful effects of fertilizer application on seedling survival have been reported with rainfall scarcity. For trials in farmers' fields in Burkina Faso, Dugué (1998) reported that the application of mineral fertilizer was not profitable in 15–48% of the cases due to water stress during the early stages of millet growth. In on-station experiments in Niger, seed-placed P application at low soil moisture decreased plant survival by 20–33% (Muehlig-Versen et al. 2003).

Table 4. Effects of different application frequencies and amounts of rockphosphate and NPK fertilizer on cereal grain and legume yields in different agro-ecological zones of Sudano-Sahelian West Africa as reported by different authors.

Amendment ^a	Amount (kg ha ⁻¹)	Yield increase above control ^b	Application frequency	Zone, soil type	References
Rockphosphate to cereals (applied in 1984)	39 (broadcast)	Millet grain 34% (measured in 1988)	Not given	Semi-arid (Niger), Arenosol	Battono and Mokwunye (1991)
Rockphosphate to cereals	130 (broadcast)	Millet grain 76%	3–10 years	Semi-arid (Niger), Arenosol	Battono et al. (1990)
Rockphosphate to cereals	130 (broadcast)	Millet grain 14–193%	10 years	Semi-arid (Niger), Arenosol	Battono et al. (1995)
Rockphosphate to cereals and legumes	130 (broadcast)	Cereal TDM 38–172% (in year 3) Legume TDM 13–128%	10 years	Semi-arid (Niger), Arenosol	Buerkert and Hiernaux (1998)
Rockphosphate compacted with soluble fertilizers	130 (broadcast)	Cereal grain 69–108%	Annually	Semi-arid (Niger), Arenosol	Battono et al. (1995)
Rockphosphate to legumes	39 (broadcast)	TDM 31% over 4 years	3-yearly	8 sites across West Africa ^d	Buerkert and Hiernaux (1998) and Buerkert et al. (2002)
Rockphosphate + NPK to legumes	39 (broadcast) + 4 P as NPK ^c placed	Range in year 3: 21–98% TDM 35% over 4 years;	3-yearly/NPK annually	8 sites across West Africa ^d	Buerkert et al. (2002)
Rockphosphate to cereals	39 (broadcast)	Range in year 3: 6–171% TDM 39% over 4 years	3-yearly	8 sites across West Africa ^d	Buerkert et al. (2002)
Rockphosphate + NPK to cereals	39 (broadcast) + 4 P as NPK ^c placed	Range in year 3: 0–203% TDM 51% over 4 years	3-yearly/NPK annually	8 sites across West Africa ^d	Buerkert et al. (2002)
P seed coating (SSP, AHP etc.)	< 0.5 mg P seed ⁻¹	Range in year 3: 65–259% Millet, TDM: 30%	Annually	Semi-arid (Niger), Arenosol	Rebafka et al. (1993a)
SSP + urea to cereals	13 (P) + 30 (N) (broadcast)	Millet grain: 45% Millet grain: 50–> 300%	Annually	Semi-arid (Niger), Arenosol	Yamoah et al. (2002)
SSP to legumes	13 (broadcast)	TDM 18% over 4 years	Annually	8 sites across West Africa ^d	Buerkert and Hiernaux (1998)
SSP to cereals	13 (broadcast)	Range in year 3: 41–127% TDM 24% over 4 years	Annually	8 sites across West Africa ^d	Buerkert and Hiernaux (1998)
SSP to legume	13 (broadcast)	Range in year 3: 59–211% Grain 18%	Annually	8 sites across West Africa ^d	Buerkert et al. 2002
SSP to cereal	8.7 (broadcast)	Millet grain 102%	Annually	Semi-arid (Niger), Arenosol	Battono and Mokwunye (1991)

SSP to cereal	13 (broadcast)	Millet grain 168%	Annually	Semi-arid (Niger), Arenosol	Bationo and Mokwunye (1991)
General response functions on large datasets		Millet straw 120% Grain yield of cereals (Y , kg ha ⁻¹) with N (kg ha ⁻¹) $Y = 2545 + 14.62N - 0.07N^2$ ($R^2 = 0.30$) $Y = 1332 + 32.08N - 0.13N^2$ ($R^2 = 0.72$) $Y = 617 + 14.34N - 16N^2$ ($R^2 = 0.36$)		Humid zone Sub-humid zone Semi-arid zone	Mughogho et al. (1986)
Partially acidulated phosphate rock (PAPR ₅₀)	Effectiveness of PAPR ₅₀ on cereal yields as compared to SSP: (no control yields reported)	56% 85% 76% -109% -142%		Humid zone Sub-humid zone Semi-arid zone Burkina Faso Nigeria	Bationo et al. (1986)

^aSSP single super phosphate, AHP Ammonium hydrogen phosphate.

^bTDM = total dry matter.

^cNPK 15-15-15.

^dSites: 5 Arenosols in semi-arid Niger, 3 Alfisols in sub-humid Togo.

Technology evaluation, transfer and adoption: neglected issues and open questions

The multitude of described technologies aiming at increasing crop yields on Sudano-Sahelian soils is in sharp contrast to their low adoption levels on farmers' fields. Supposing that the small-scale agro-pastoralists predominating in this area must make rational decisions in order to survive in a harsh environment, questions must be raised about which issues may have been neglected in experiments and feasibility studies performed so far. It appears that there are at least the following.

Capital availability and labour costs

A number of authors have pointed to the problem of subsistence farmers not having enough capital to build up fertility on the geologically very old West African soils which are much lower in nutrients and SOM than soils in other parts of the world, except Australia (Breman et al. 2001). In the late 1990s this has been used to advocate large public investment programs such as a World Bank initiative to 'recapitalize' soil fertility in sub-Saharan West Africa, partly based on the use of locally available rockphosphates (Mokwunye 1995; Mokwunye et al. 1996; Scoones and Toulmin 1999). Even if investment needs may be high for some of the technologies advocated, there are two arguments against the claim that lacking capital availability is the major obstacle for innovation at the farmers' level. First, needs for external capital are certainly low for mulching techniques, whereas they may be medium for the application of farmyard manure and corraling and high for rockphosphates and the application of manufactured fertilizers such as SSP or P-coated seeds. Installation and maintenance of fodder-banks and leguminous leys also tend to be both cost and labour intensive. If low capital was indeed limiting technology adoption one would therefore expect that farmers practise mulching much more intensively than they do at present where at the end of the dry season many still burn large amounts of stover on their fields to get rid of it as a nuisance for subsequent weeding. Second, across the Sudano-Sahelian zone even small farmers readily invest in counter-season crops, typically planted in small, clay-rich depressions, in rice fields or in peri-urban

agriculture. It thus appears as if, rather than the capital status of the farmer, the ratio between investments and expected returns as well as 'risk of failure' estimates govern the decision about whether or not an investment is made in soil amendments.

The timely availability of labour and real labour costs seems to be another often overlooked factor governing investment in soil fertility measures. Labour needs can be classified as low for corraling and medium for the practices of mulching and fertilizer application. They are high for the zaï technique, compost making and hand-spreading of compost and for the application of household waste and farmyard manure. However, the scarcity of reliable labour estimates for these technologies complicates the evaluation of their applicability and attractiveness; in fact, their neglect is seen as a major cause for the non-adoption of technologies that seemed to be highly promising from a biophysical point of view (Bationo et al. 1998). This is illustrated by data of Lamers' (unpublished) who valued net returns to labour of different mulching and fertilizing treatments in four villages of south-western Niger. Although annual crop residue mulch application at 2000 kg ha⁻¹ without or in combination with application of P and N fertilizers resulted in high millet yield increases at the same sites (Buerkert et al. 2000), the total net returns to labour were always highest for the untreated control and only occasionally positive for mulching and fertilizer treatments at the site with the most favourable pedologic and climatic conditions (Figure 2).

One problem in this context may be that economic modelling which assesses the attractiveness or profitability of technologies does often not detail labour and capital needs for the individual operations related to a technology. In model approaches labour costs of activities are often considered at an aggregated seasonal or annual level (Shepherd and Soule 1998; Barbier and Carpentier 2000). Aggregating labour costs for field preparation, seeding, manure or fertilizer application, weeding and harvest, such as in the exhaustive WOCAT² knowledge base may disguise treatment effects on labour requirements during critical periods. An exception to this is the model

²WOCAT World Overview of Conservation Approaches and Technologies; <http://www.wocat.org>

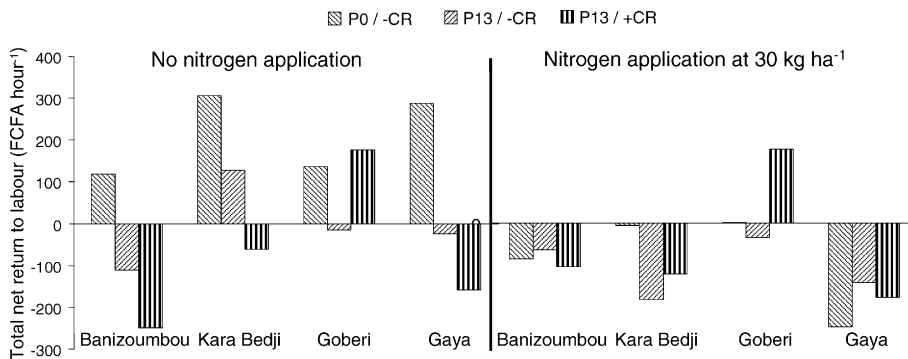

Figure 2. Total net returns to labour of different millet fertilization strategies at four locations in Niger, 1998 (Lamers et al. unpublished data). P0/P13: application of 0/13 Kg P ha⁻¹. -CR/+CR: application of 0/2000 Kg ha⁻¹ crop residue mulch.

of Van Duivenbooden and Veeneklaas (1993), which considers labour requirements for individual field operations. Unlike Lamers et al. (1998), most modelling papers also do not disclose the absolute costs and profits to the reader, which makes conclusions beyond the site-specific context very difficult. Certainly, labour requirements for operations such as weeding and harvesting also depend on the biomass and grain production of weeds and crops, respectively. Other operations, such as field preparation, sowing and starter fertilization require a relatively fixed amount of labour per hectare, but will vary between manual and mechanized methods (Hengsdijk and Van Keulen 2002).

Another major issue of concern in the existing economic evaluation of soil fertility technologies in SSWA are the assumed costs of farm labour themselves. Most agricultural economists base the calculation of the profitability of soil fertility technologies on labour costs at local labour markets, whereas in SSWA many field owners and farm managers travel to major coastal cities to earn a living during prolonged periods of the year. To unravel farmers' decision making processes and opportunity costs for labour, it may therefore be interesting to at least alternatively consider costs of farm labour based on these activities. Another problem is that economic modellers may not be aware of side conditions governing the availability and accessibility of inputs needed for a particular technology. A good example for this is that the experimentally most widely tested rate of crop residue mulch, an annual application of 2000 kg ha⁻¹, is unrealistically high for farmers in

the Sahelian zone, given the many alternative uses of this resource (Lamers and Feil 1993), and the like applies to mulching with unpalatable grasses. However, some of these issues have now been recognised (Scoones and Toulmin 1998; Schlecht and Buerkert 2004) and taken into account in more recent research approaches (Buerkert et al. 2001; Muehlig-Versen et al. 2003).

Geographical and temporal scales

In recent years, the large short-distance variation in crop growth typically observed on sandy Sahelian soils has been an intensively studied phenomenon. Reflecting both, the effects of land use history and present farmers' judicious management practices ('precision farming'), its consequences for farmers' livelihoods and technology adoption continues to be debated. At an experimental level it has been shown that this micro-variability can interact with soil amendment effects on crops or with leaching losses (Buerkert et al. 1995; Buerkert and Stern 1995; Brouwer and Powell 1998; Florax et al. 2002; Gandah et al. 2003). Whether farmers explicitly exploit the micro-variability of their fields to minimize the effects of rainfall-related risks of crop failure or have just learned to cope with it as a consequence of scarce internal resources to enhance soil productivity (manure, crop residues, compost, branches from perennial plants) which are applied on spots of highest returns, has been discussed intensely (Brouwer et al. 1993; Haigis 2000; Mazzucato and Niemeijer 2001; Schlecht and

Buerkert 2004). Whatever the case, any realistic assessment of economic benefits of alternative technologies under on-farm conditions and predictions about farmers' adoption behaviour will require a comprehensive understanding of where and at what scale farmers would likely apply them, at least initially, within their complex land use system.

The interaction between short-distance variability in treatment responses of crop yields at the field scale appears to be mirrored at a larger scale. In a multi-site benchmark experiment, Buerkert et al. (2000) showed that the yield increases in TDM after 4 years of crop residue mulch application at 2000 kg ha⁻¹ varied between 13 and 72% at four Sahelian sites (Arenosols; 500–600 mm a⁻¹, millet) but was only 10% at two Sudanian sites (Alfisols; 1100–1300 mm a⁻¹, maize and sorghum). Subsequent multi-site time trend analyses indicated that mulch effects on cereal dry matter yield depended largely on the soil type. Hereby, the base saturation of the sandy Sahelian soils was a major parameter for the prediction of mulch effects on cereal yields (Buerkert et al. 2001, 2002). Similar results were also obtained for RP application where the magnitude of effects depended on pH or base saturation, rainfall and the simultaneous application of soluble P to the pocket at seeding (Buerkert et al. 2001, 2002).

The experimentally demonstrated spatial variability of treatment effects at different geographical scales is accompanied by a temporal component leading to interactions that need to be taken into account in evaluation schemes to understand farmers' management strategies. Soil organic matter, for instance, can be separated into a coarse (> 50 μm) and a fine (< 50 μm) fraction (Feller and Beare 1997). The decomposition of the coarse SOM fraction by meso- and micro-fauna activities determines the amounts of nutrients recycled to the soil (Manlay et al. 2004). The fine SOM fraction mineralises slowly, as was illustrated by a double-pool exponential model fitted to decomposing organic matter in Sahelian soils (Somda et al. 1995). Such longer-term decomposition processes of fine SOM are presumably responsible for residual effects of mulching and manuring treatments. With manure application to pearl millet, beneficial effects on grain and stalk yields were observed up to 4 years after application of even modest rates of manure (Schlecht

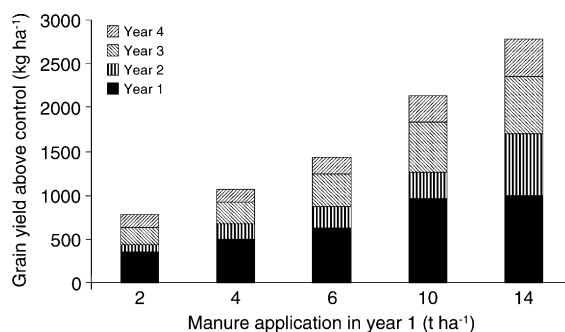

Figure 3. Millet grain yield above control as affected by manure application at 2–14 t ha⁻¹ in year 1 and residual effects until year 4 (Schlecht et al. 2004).

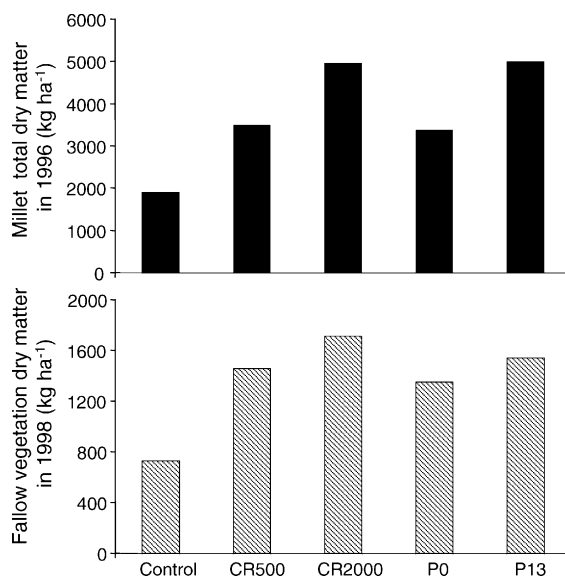

Figure 4. Effects of annually applied soil amendments on millet total dry matter and residual effects of these treatments 2 years after closure of the experiment on the above-ground dry matter of the fallow vegetation. Treatments were an absolute control, annual crop residue mulching at 500 (CR500) and 2000 (CR2000) kg ha⁻¹, and treatment means without P (P0) and annual application of 13 kg P ha⁻¹ (P13). Modified after Gérard et al. (2001).

et al. 2004; Figure 3). Moderate residual effects of crop residue mulch on millet biomass yields were also determined for up to four cropping periods in a pot trial (Powell et al. 1999) and in a field study (Figure 4).

At an intermediate time scale, the decomposition process of SOM is also influenced by the

N-concentration of the applied material: at $> 20 \text{ g N kg}^{-1}$ organic material generally decomposes faster than at lower N levels (Stevenson and Cole 1999). With livestock manure, an observed temporary immobilization of mineral soil N was attributed to undigested cell wall components in the faeces, even at higher N levels in the amendment (De Ridder and Van Keulen 1990; Powell et al. 1999). In addition, seasonal differences in the decomposition and mineralisation of applied organic matter occur, which are due to variations in soil temperature, rainfall and soil moisture (Somda et al. 1995; Esse et al. 2001; Schlecht and Buerkert 2004). Van der Pol (1992) raised the problem that temporal changes in the nutrient release following mineralisation of applied organic matter are not sufficiently assessed in most studies. This issue was subsequently taken up by Smaling et al. (1996), who concluded that the spatio-temporal dynamics of organic matter decomposition and nutrient stocks at different nutrient levels are still poorly understood. To our knowledge, not much has changed in this respect since then. Such an understanding, however, is needed for a better appreciation and exploitation of the effects of SOM mineralization on soil productivity and crop growth. There is mounting evidence that African farmers are well aware of the residual effects of organic soil amendments, and are accounting for these in their land use and cropping strategies (Evéquo et al. 1998; Powell et al. 1999; Schlecht et al. 2004).

The human component of soil fertility management

Dent et al. (1995) and Bationo et al. (1998) pointed to the fact that technology adoption depends to a large extent on socio-economic and socio-cultural factors, which until recently, have been largely ignored in the context of soil fertility research in West Africa. Stoorvogel et al. (1995) viewed individual farmers as the final decision makers, whose decisions are conditioned by their resource endowments, household goals and socio-economic environment. Dent et al. (1995) and Mazzucato and Niemeijer (2001) stated that in many agricultural societies, decisions of a single manager are the result of agreements with family members, friends, neighbours and larger social networks.

In addition to that, the (individual) perception of soil fertility is multi-faceted, dynamic and contextual: Warren (2002) observed that a household's resource endowment strongly influenced the extent of erosion on individual fields, with well-endowed farmers paying less attention to soil conservation measures than poorer ones. Similar results were obtained from bio-economic modelling of nutrient management by Kenyan farmers (De Jager et al. 1998). In addition to that, different social arrangements, different perceptions of the future and changing time horizons diversify the appraisal of a particular resource and its state of degradation. Therefore, Warren (2002) argues that the evaluation of land degradation (or soil fertility) cannot be limited to assessments of soil parameters, nutrient budgets or household economics. If this view is accepted, the evaluation of soil fertility and identification of measures that might help to improve it becomes very complicated.

At present, the perception on future development of soil fertility at the regional level is changing from the pessimistic views of the 1980s and 1990s (Penning de Vries and Djitéye 1982; Van Keulen and Breman 1990; Van der Pol 1992; Stoorvogel et al. 1993) to more optimistic evaluations. From the analysis of the correlation between area productivity and long-term average rainfall, rural population density, animal traction index, fertilizer and manure usage, soil and water conservation measures and agricultural extension across Burkina Faso, it appeared that area productivity was mainly influenced by rainfall, but was barely related to rural population density or use of technology and soil amendments (Mazzucato and Niemeijer 2001). This was attributed to the high specificity of soil fertility management based predominantly on internal organic resources, labour input and social networks. These findings put into question the belief that the low use of external inputs in the Sahel will result in rapid region-wide soil depletion (Mazzucato and Niemeijer 2001). The view of the latter authors is partly based on the comparison of nutrient contents of soil samples taken in the same region at an interval of 30 years. From these it appeared that the N, P and K levels of cultivated surface soils were higher than those of long-term fallowed ones, leading to the conclusion that farmers had developed strategies to maintain or even raise soil fertility over time. In our view, two points were

neglected in the discussion of these results, which might lead to different conclusions: (i) the fact that long-term fallow plots are often situated on marginal lands with inherently low soil fertility, whereas cropland is normally only extended to marginal lands when cultivation pressure increases (Warren 2002) and (ii) the different rooting patterns and annual biomass production of annual crops as compared to a perennial fallow vegetation.

Abdoulaye and Lowenberg De Boer (2000) compared different technologies for improving soil fertility on sandy soils in the Sahel using multiple goal linear programming. For three categories of farmers they found that resource-poor farmers are reluctant to use mineral fertilizers, whereas medium-off farmers applied 66 kg SSP ha⁻¹ and well-off farmers applied the nationally recommended 90 kg SSP ha⁻¹ and 45 kg urea ha⁻¹. The authors concluded that decreasing land availability will increase capital availability per unit of land. Their model predicted that with increasing capital availability, farmers will first intensify the traditional manure application and cropping techniques. As sources of internal amendments are subsequently being exhausted, a gradual shift to the use of mineral fertilizers will be observed especially by medium and well-off farmers. In accordance with these predictions, a significant use of inorganic fertiliser within West Africa was observed at population densities above 40–60 inhabitants per km² (De Ridder et al. 2004). The intensified soil fertility management was primarily ascribed to increasing population density, land scarcity and the development of input and output markets. Examples frequently cited to sustain this reasoning are the Machakos district in south-eastern Kenya (Tiffen et al. 1994), the Kano close settled zone in northern Nigeria (Harris 1998, 2000) and the neighbouring Maradi region in south-eastern Niger (Mortimore et al. 2001). Whether these conclusions can be extrapolated to the entire, very heterogeneous Sudano-Sahelian region is debatable, especially since the observations of Harris (1998) and De Ridder et al. (2004) originate from a small number of farmers and villages, respectively. Certainly, sweeping nutrient budget analyses like the ones by Van der Pol (1992) and Stoorvogel et al. (1993) produced scenarios that, after about 10 years of verification at specific sites, proved to be too pessimistic. How-

ever, it does not seem justified to now go too far in the opposite direction and conclude that the site-specific knowledge and judicious but poverty-driven soil fertility management techniques of farmers and the continued population increase with all its socio-economic consequences will automatically lead to more productive and sustainable land use systems across the region.

Guiding research and extension through comprehensive technology evaluation

A straightforward approach for *ex-ante* testing of the suitability of technologies for a specific biophysical and socio-economic environment was presented by Haigis et al. (1998). In their approach, the technologies have to pass a series of filters consisting of agro-ecological variables (soils, rainfall, sustainability), followed by technical (management requirements), institutional (accessibility of input/output markets, extension services) and sociological variables (gender issues, taboos, prestige, visibility of success), and lastly an economic filter evaluating the technologies' gross margin or internal rate of return. Only those innovations that pass all filters are judged suitable for adoption in the setting they have been tested for. Although useful for a quick screening of technologies, this qualitative approach seems only partly suited to detect gaps in existing knowledge bases, guide further research and provide possibilities for *ex-ante* testing of the impact of technologies or policies at the farm, regional or national scale. Several of these options are provided by different types of models that will be examined in the following.

In the context of natural resource management and the reproduction of interactions between climate, soils, plants, livestock, men and society, the most frequently encountered models are statistical models, programming models, simulation models and combinations of these, with either biophysical or socio-economic emphasis, or combinations of both elements. Bio-economic models simulate biophysical processes and economic activities based on optimization algorithms (Barbier and Carpentier 2000). Hereby, agro-ecological simulation models define input requirements and predict output levels for production activities such as cropping, and livestock husbandry. Since

socio-economic parameters guide farmers' decision making about what and how to produce, their relative attractiveness is most appropriately determined by linear programming (Ruben et al. 1998). An important criterion for model selection is the level of complexity or aggregation, which is needed for data evaluation.

Technology evaluation by models

Various modelling approaches provide possibilities for an *ex-ante* assessment of the potential benefits of (new) technologies at the farm scale and at the same time allow to identify policy measures to make their adoption feasible (Ruben et al. 1998). Since land use and land management are determined by biotic and abiotic environmental factors as well as the farm households' endowment with production assets, by the regional infrastructure and markets, agro-ecological and socio-economic aspects have to be considered simultaneously.

An approach that accounts for biophysical processes but does not optimize functions is the NUTMON programme (Van den Bosch et al. 1998), which at present is probably the most frequently used toolbox in the context of soil fertility research in sub-Saharan Africa (Schlecht and Hiernaux 2004). NUTMON, which evolved from the widely recognized nutrient balance calculations of Stoorvogel and Smaling (1990), is a static approach that enables the systematic calculation of SOM and nutrient balances. Through indication of nutrient deficits or surpluses at the level of individual farm units (such as a home garden or a field), NUTMON can help to identify needs for changes in site-specific soil fertility management. De Jager et al. (1998) coupled the NUTMON toolbox with a statistical economic approach (ECMON) to quantify economic performance indicators at the activity level (gross margin and cash flow per unit area) and farm household level (net farm income and family earnings), and valued depleted soil nutrients according to the market value of an equivalent amount of fertilizer. However, so far the tool does not allow to specify labour requirements for defined operations, opportunity costs of land and labour, input and output prices and off-farm income. Moreover, seasonal and annual variation, such as in input and output prices, is not yet accounted for (De Jager et al. 1998).

A bio-economic model which is based on interactive multiple goal linear programming was built to analyse agricultural development options for a large region in semi-arid Mali (Van Duivenbooden and Veeneklaas 1993; Van Duivenbooden 1993). For different objectives, the model allows defining goal variables that have to be optimized individually, while a set of restrictions is imposed on the other goal variables. The model covers all major agricultural activities of the region, including potential ones, and quantifies all known relations among these activities and between activities and natural and human resources. In this way flow processes for nutrients as well as labour requirements for individual operations and activities are specified and quantified. The approach can be used to examine the consequences of changing land use, intensification of crop and livestock production, and degree of exploitation of natural and human resources. Operating at a regional scale, the model is not suited for an evaluation of individual technologies at the farm level but can be used to guide decisions concerning agricultural development and policies at the level of districts or provinces. However, the disaggregated and explicit nature of input variables makes the model very data demanding.

Shepherd and Soule (1998) presented an economic-ecological simulation model that links biophysical and economic processes at the farm scale. The ecological sub-model comprises livestock, crop production, organic amendments and soil nutrient balances. It permits to screen a wide range of soil management options and to link soil management practices to soil nutrient availability and plant productivity. The approach is dynamic and recursive, in that a current year's agricultural production and management decisions affect the quantitative availability of nutrients for next year's production. For SOM and the various soil nutrients, the ecological sub-model assesses time trends in the supply capacity which can be used as indicators of soil productivity. The economic sub-model uses the outputs from the ecological sub-model (such as grain or milk production) to calculate economic returns. Predicted time changes in nutrient supply serve as agronomic indicators of the sustainability of farming systems or practices, respectively. In this way the long-term effects of existing and improved agricultural practices on nutrient cycling and nutrient availability, plant

production and farm income are assessed. However, seasonality in rainfall, nutrient availability, fodder quality, commodity prices and labour demand is not accounted for. Due to the numerous parameters considered, the approach is very data demanding.

A large number of crop simulation models has been developed and partly been applied to African crops and cropping conditions (Bouman et al. 1996; Van Ittersum et al. 2003). Some of these models, like APSIM,³ proved very useful for modelling the development of various cereals and legumes and of their associations under a wide range of biophysical conditions. Although initially focussing on the soil–crop interface, APSIM models have recently been coupled with economic models and now allow a broader simulation of farming systems and testing of chances for technology adoption (Keating et al. 2003). However, neither of these models has yet been validated in SSWA.

Targeting different types of low input farming systems in West Africa, Sissoko (1998) and La Rovere (2001) adjusted an earlier linear programming approach (Hengsdijk and Kruseman 1992; Kruseman 2000). To assess the sustainability of farming systems, the approach combines a technical coefficient generator for biophysical processes and an economic multi-goal linear programming model which maximises utility functions under criteria such as maximum production, food security, income generation or soil fertility maintenance. The model is run at the level of farm households and takes account of climate, soils, primary and secondary production components, storage and redistribution facilities, labour and monetary flows. Several intensification levels can be defined to simulate the adoption of different soil fertility management strategies and technologies and the impact of policies under one or several of the above criteria, for selected farm types and alternative biophysical and socio-economic settings. Despite iteration routines that permit to predict medium-term trends in key parameters such as labour requirements, land use, soil fertility status, food security and economic performance (La Rovere 2001), the approach is essentially static.

The agro-ecological sub-model presented by Ruben et al. (1998) addresses existing and potential production technologies and is based on a holistic assessment of biophysical processes, such as crop growth in relation to input use, while the socio-economic sub-model focuses on human behaviour and incentives for the choice among currently available agricultural technologies. The approach aims at exploiting the maximum biophysical production possibilities for a farm or a region and at indicating tradeoffs between different production objectives (Ruben et al. 1998). It has been used to assess the influence of agrarian policies on management decisions of farmers in Southern Mali (Ruben and Van Ruijven 2001).

However, Dent et al. (1995) argued that the complexity of farmers' social systems, the insufficient knowledge by researchers about such systems and inconsistencies in preferences and beliefs of individual actors and stakeholders render normative methods, such as optimization models, unsuitable to describe individual decision-making. They therefore proposed the use of decision rules in combination with simulation models. One decision rules model, calibrated and validated in the cotton growing zone of southern Mali, was presented by Struif Bontkes (1999). A farm sub-model accounts for soil and climatic factors, factors related to crop and livestock production, and labour requirements. Time-related changes in parameters determining soil fertility (particularly C_{org} , N, soluble P and soil pH), crop and livestock production, food supply, farm income and employment status are simulated for four different farm types. In this way the impact of technologies on these parameters at the level of different farms can be explored. Data inputs for the connected regional sub-model are the outputs – for each farm type – of the farm sub-model. While the farm types themselves remain unchanged, the number of farms of each type evolves from an initial setting, depending on farm performance, farmer retirement, succession, partitioning of land and migration. The occurrence of these events is affected by decision rules which are influenced by the age of farmers, household demography, farm performance and market prices. However, social arrangements such as labour and land contracts between households, or livestock entrustments are not included in the regional sub-model. Again, alternative management options, technologies and

³APSIM Agricultural Production Systems sIMulator (<http://www.apsru.gov.au/apsru/Products/Publications/APSIM>).

policies can be tested at the regional level for scenarios with set demography, tenure rules and markets. However, the farm sub-model requires the calibration of numerous functions against recognized farming system dynamics, while the functions used in the regional sub-model are based on fixed decision rules.

Existing social relations such as exchange of labour or animals, and communal resource management in a rural community in Burkina Faso were taken into account by the model of Barbier (1998), along with shadow prices of production factors which indicate their scarcity. The approach combined a recursive and dynamic linear programming model of farmers' economic behaviour with a biophysical model predicting crop yields and land degradation for different types of land use and cropping patterns, under constraints such as risk aversion, land scarcity, soil fertility decline, labour and cash availability. It was thus used to evaluate alternative technologies, taking into account their respective benefits, constraints and costs. Recently, aspects such as communal resource management or labour provision through social networks are reproduced through Multi Agent Systems (MAS). Agents are physical or virtual entities (that is actors or stakeholders) that possess or manage certain resources, can work and communicate with other agents and can offer services in the environment. In the MAS approaches, the agents' behaviour is driven by a set of objective functions, survival functions or decision rules, which the model tries to optimize (Ferber 1999). In agricultural sciences, the use of MAS is only at its beginning, but the published examples demonstrate the usefulness of the tool in the modelling and evaluation of managerial aspects of natural resource use, for example for communal irrigation schemes (Feuillette et al. 2003; Barreteau et al. 2004).

Land use planning models

While the bio-economic models vary widely in their approach and scope, the upcoming land use planning models provide a more homogenous setup and orientation. They therefore seem particularly promising for *ex-ante* testing of soil fertility management technologies. The majority of approaches is based on simulation models: crop and livestock

simulation models replicate the productive potential of farm sub-units and generate input variables for subsequently employed economic optimization models which simulate farmers' land allocation and land management decisions. The comparison of the simulated to the original land use demonstrates the environmental effect of decisions. An example is the USTED⁴ methodology (Stoorvogel et al. 1995), which concentrates on particular land units (e.g., a field) together with their type of use (e.g., maize cultivation) and specific technology options applied (e.g., fertilizer use). For this entity of land use and corresponding technology, the respective inputs and outputs for agricultural production and the requirements of the technology in terms of capital and labour are specified. Scenarios determined by changes in socio-economic or biophysical parameters are tested through optimization of land use × technology options by linear programming. The actual or assumed availability of resources sets the model constraints, and additional restrictions can be introduced concerning sustainability parameters (e.g., a minimal soil nutrient concentration). In this way, suitable combinations of land use and technology options are identified for individual farm types, whereby costs of inputs and labour, the value of production, and eventually the values of defined sustainability parameters are specified. Despite some limitations of the approach, the USTED methodology offers useful features for the evaluation of resource management technologies, since it operates at the scale of well-defined farm types, allows for simulation of biophysical processes at that level and specifies the necessary inputs and outputs for technology options. However, Stoorvogel and Antle (2001) point to the fact that geographical scales may vary within a land use analysis approach, since processes take place at different scales (plot, farm, watershed, region) but have to be analysed simultaneously because they interact. Similar problems exist at the time scale. Instead of trying to upscale or downscale different processes to one level, Stoorvogel and Antle (2001) advice to analyse each process at its appropriate geographical scale and adjust scales *ex-post*.

For visualization of initial characteristics of land units, land allocation, land management and

⁴USTED Uso Sostenible de Tierras En el Desarrollo, sustainable land use in development.

survey data, land use models are normally linked to a Geographical Information System (GIS). Likewise, the GIS can be used to visualize model results, which facilitates the discussion of problems and identification of solutions by different actors. This is particularly helpful in the west African context where farmers often have a profound understanding of spatial relations within their region (Osbahr and Allen 2003).

Modelling vs. field research?

The analysis of relevant studies on soil fertility and soil fertility restoration in SSWA reveals several shortcomings. Among these, the poor comparability of results across locations and climatic gradients seems to be one important reason for the frequent failure of technology transfer beyond a specific study region. Another weak point is the yet unsatisfactory consideration of the small-scale spatial variability of soil characteristics that is at the basis of the systems' inherent buffering capacities and farmers' management strategies. Likewise, residual effects of technologies, especially those improving soil nutrient and organic matter content or longer-term soil fertility and productivity, are frequently taken into consideration by farmers but only occasionally by scientists. The poor documentation of the availabilities and requirements of amendments, labour and capital for specific technologies at the level of farm households, communities or regions and the inconsistent and incomplete concomitant consideration of biophysical and socio-economic parameters that determine soil fertility and its management also jeopardize the success of technology transfer. However, there exists a wealth of detailed though discrete data on biophysical and socio-economic aspects of soil fertility and its management in SSWA, which merits to be compiled in a quantifying, publicly accessible soil fertility database. Here, all experimental and monitoring data, and the related qualitative and quantitative biophysical and socio-economic parameters should be entered as detailed as possible, building on existing networks such as AfNet⁵ and knowledge bases such as WOCAT. The constitution of this database would already help identify existing gaps in present

knowledge and thus target further basic and applied soil fertility research. Since it will contain data obtained across different agro-ecological zones, the database should mirror the large-scale spatial variability of climate and soils which affect technology performance. Beyond this, the database should supply input variables for modelling exercises aiming at *ex-ante* testing of technologies and policies enabling soil fertility restoration from the farm to the regional scale, thereby accounting for specific agro-economic settings.

Although normally used at regional scales to provide guidelines for policy decisions, models developed for land use planning might also be adapted to test alternative soil fertility management options at the scale of well-defined types of plots and farms. However, for an *ex-ante* assessment of the suitability of technologies, the ability of the approaches to account for seasonal variation in production factors and management modes, and for small-scale spatial and longer-term temporal variability in biophysical and/or socio-economic parameters has to be improved. Long-term effects of investments in soil fertility can only be evaluated within a framework that considers realistic opportunity costs of land, labour and capital within and outside the agricultural sector. Therefore, the analytical tools need to broaden their focus towards aspects of factor substitution (Ruben et al. 1998).

The mandatory presentation and discussion of model results with farmers and other stakeholders will be facilitated if they are visualized. It is hoped that in the course of this mutual analysis by stakeholders and scientists contextual factors that were not yet accounted for in the model but nevertheless have an impact on the adoption of a technology are identified. These factors should then be included in the biophysical or socio-economic modules (Figure 5).

Used in this way, modelling exercises could guide basic and participatory research and increase the socio-economic compatibility of biologically and technically sound soil fertility management strategies that are applied under defined biophysical and socio-economic settings specified at the scale of farms, communities and regions. However, the usefulness of solutions to specific soil fertility problems as derived from modelling will always be limited by the most poorly quantified parameters or processes

⁵AfNet African Network for Soil Biology and Fertility.

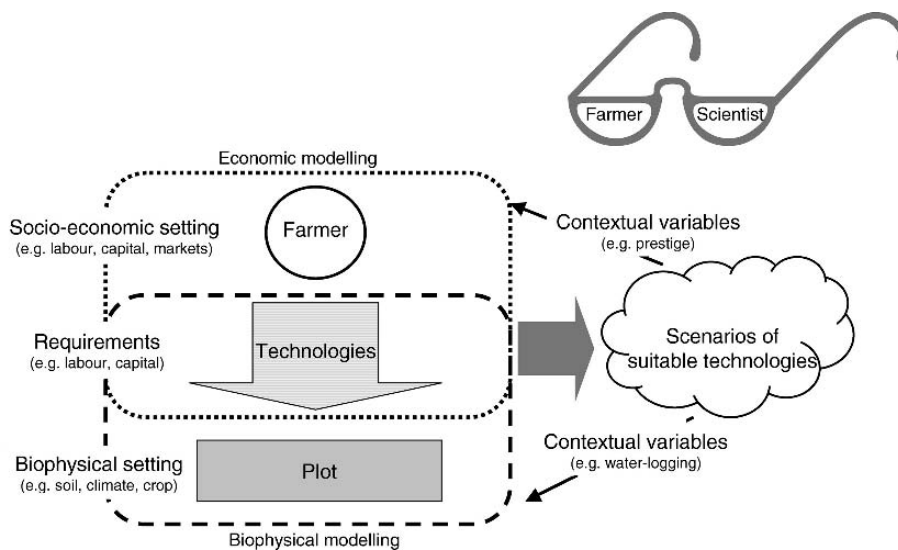

Figure 5. Conceptual framework for an agro-economical modelling approach for technology evaluation based on both farmers' and scientists' views and data.

(modules), and the interpretation of the results will therefore need care.

Acknowledgement

We thank the organizers of the AfNet-TSBF Symposium 2004 for inviting the two first authors to the 2004 Yaounde symposium thereby initiating the writing of this article.

References

- Abdoulaye T. and De Boer J. 2000. Intensification of Sahelian farming systems: evidence from Niger. *Agric. Syst.* 64: 67–81.
- Akinnifesi F.K., Smucker A.J.M. and Kang B.T. 1999. Below-ground dynamics in agroforestry systems. *Ann. Arid Zone* 38: 239–273.
- Akonde T.P., Leihner D.E. and Steinmueller N. 1996. Alley cropping on an Ultisol in subhumid Benin. 1. Long-term effect on maize, cassava and tree productivity. *Agroforest. Syst.* 34: 1–12.
- Akonde T.P., Kuhne R.F., Steinmueller N. and Leihner D.E. 1997. Alley cropping on an Ultisol in subhumid Benin. 3. Nutrient budget of maize, cassava and trees. *Agroforest. Syst.* 37: 213–226.
- Alvey S., Bagayoko M., Neumann G. and Buerkert A. 2001. Cereal/legume rotations affect chemical properties and biological activities in two West African soils. *Plant Soil* 231: 45–54.
- Alvey S., Yang C.H., Buerkert A. and Crowley D.E. 2003. Cereal/legume rotation effects on rhizosphere bacterial community structure in West African soils. *Biol. Fert. Soils* 37: 73–82.
- Bacýé B., Moreau R. and Feller C. 1998. Décomposition d'une poudrette de fumier incorporée dans un sol sableux de versant et un sol argilo-limoneux de bas-fond en milieu Soudano-Sahélien. *Etude Gest. Sols* 5: 83–92.
- Bagayoko M., Alvey S., Buerkert A. and Neumann G. 2000a. Root-induced increases in soil pH and nutrient availability to field-grown cereals and legumes on acid sandy soils of West Africa. *Plant Soil* 225: 117–127.
- Bagayoko M., Buerkert A., Lung G., Bationo A. and Römheld V. 2000b. Cereal/legume rotation effects on cereal growth in Sudano-Sahelian West Africa: soil mineral nitrogen, mycorrhizae and nematodes. *Plant Soil* 218: 103–116.
- Bagayoko M., George E., Roemheld V. and Buerkert A. 2000c. Effects of mycorrhizae and phosphorus on growth and nutrient uptake of pearl millet, cowpea and sorghum on a West African soil. *J. Agric. Sci., Camb.* 135: 399–407.
- Barbier B. 1998. Induced innovation and land degradation: results from a bioeconomic model of a village in West Africa. *Agric. Econ.* 19: 15–25.
- Barbier B. and Carpentier C. 2000. The conditions for sustainability of tropical agriculture. Bioeconomic models applied to five contrasting farming systems, Paper presented for the mini-symposium on modelling at the International Association of Agricultural Economists conference in Berlin, August 2000. Available online at <http://www.zef.de/download/iaae-symp/barbier-paper.pdf>.
- Barreteau O., Bousquet F., Millier C. and Weber J. 2004. Suitability of multi-agent simulations to study irrigation system viability: applications to case studies in the Senegal River valley. *Agric. Syst.* 80: 255–275.
- Bationo A. and Buerkert A. 2001. Soil organic carbon management for sustainable land use in Sudano-Sahelian West Africa. *Nut. Cyc. Agroecosyst.* 61: 131–142.

- Bationo A. and Mokwunye A.U. 1991. Alleviating soil fertility constraints to increased crop production in West Africa: The experience in the Sahel. In: Mokwunye A.U. (eds), *Alleviating Soil Fertility Constraints to Increased Crop Production in West Africa*. Kluwer Academic Publishers, Dordrecht, The Netherlands, pp. 195–215.
- Bationo A. and Ntare B.R. 2000. Rotation and nitrogen fertilizer effects on pearl millet, cowpea and groundnut yield and soil chemical properties in a sandy soil in the semi-arid tropics, West Africa. *J. Agric. Sci., Camb.* 134: 277–284.
- Bationo A., Christianson B.C. and Klaij M.C. 1993. The effect of crop residue and fertiliser use on pearl millet yields in Niger. *Fert. Res.* 34: 251–258.
- Bationo A., Lompo F. and Koala S. 1998. Research on nutrient flows and balances in West Africa: state-of-the-art. *Agric. Ecosyst. Environ.* 71: 19–36.
- Bationo A., Mughogho S.K. and Mokwunye A.U. 1986. Agronomic evaluation of phosphate fertilisers in tropical Africa. In: Mokwunye A.U. and Vlek P.L.G. (eds), *Management of Nitrogen and Phosphorus Fertilisers in Sub-Saharan Africa*. Martinus Nijhoff, Dordrecht, The Netherlands, pp. 283–318.
- Bationo A., Christianson B.C., Baethgen W.E. and Mokwunye A.U. 1992. A farm-level evaluation of nitrogen and phosphorus fertiliser use and planting density for pearl millet production in Niger. *Fert. Res.* 31: 175–184.
- Bationo A., Sedogo M.P., Buerkert A. and Ayuk E. 1995. Recent achievement on agronomic evaluation of phosphorus fertilizer sources and management in the West Africa semi-arid tropics. In: Ganry F. and Campbell B. (eds), *Sustainable Land Management and African Semi-arid and Subhumid regions*. Proceedings of the SCOPE Workshop, 15–19 November 1993, Dakar, Senegal. CIRAD, Montpellier, France, pp. 99–109.
- Bationo A., Chien S.H., Henao J., Christianson B.C. and Mokwunye A.U. 1990. Agronomic evaluation of two unacidulated and partially acidulated phosphate rocks indigenous to Niger. *Soil Sci. Soc. Am. J.* 54: 1772–1777.
- Bosma R.H., Bos M., Kante S., Kebe D. and Quak W. 1999. The promising impact of ley introduction and herd expansion on soil organic matter content in southern Mali. *Agric. Syst.* 62: 1–15.
- Bouman A.M., Van Keulen H., Van Laarh H.H and Rabbinge R. 1996. The 'School of de Wit' crop growth simulation models: a pedigree and historical overview. *Agric. Syst.* 52: 171–198.
- Breman H. and De Wit C.T. 1983. Rangeland productivity and exploitation in the Sahel. *Science* 221: 1341–1346.
- Breman H. and Kessler J.J. 1997. The potential benefits of agroforestry in the Sahel and other semi-arid regions. *Eur. J. Agron.* 7: 25–33.
- Breman H., Groot J.J.R. and Van Keulen H. 2001. Resource limitations in Sahelian agriculture. *Glob. Environ. Change* 11: 59–68.
- Brenner A.J., Jarvis P.G. and den Beldt R.J. 1995. Windbreak-crop interactions in the Sahel. 1. Dependence of shelter on field conditions. *Agric. Forest. Meteorol.* 75: 215–234.
- Bristow A.W., Whitehead D.C. and Cockburn J.E. 1992. Nitrogenous constituents in the urine of cattle, sheep and goats. *J. Sci. Food Agric.* 59: 387–394.
- Brouwer J. and Powell J.M. 1998. Increasing nutrient use efficiency in West-African agriculture: the impact of micro-topography on nutrient leaching from cattle and sheep manure. *Agric. Ecosyst. Environ.* 71: 229–239.
- Brouwer J., Fussel L.K. and Herrmann L. 1993. Soil and crop growth micro-variability in the West African semi-arid tropics: a possible risk reducing factor for subsistence farmers. *Agric. Ecosyst. Environ.* 45: 229–238.
- Buerkert A. and Lamers J.P.A. 1999. Soil erosion and deposition effects on surface characteristics and pearl millet growth in the West African Sahel. *Plant Soil* 215: 239–253.
- Buerkert A. and Hiernaux P. 1998. Nutrients in the West African Sudano-Sahelian zone: losses, transfers and role of external inputs. *J. Plant Nutr. Soil Sci.* 161: 365–383.
- Buerkert A. and Stern R.D. 1995. Effects of crop residue and phosphorus application on the spatial variability of non-destructively measured millet growth in the Sahel. *Expl. Agric.* 31: 429–449.
- Buerkert A., Bationo A. and Dossa K. 2000. Mechanisms of residue mulch-induced cereal growth increases in West Africa. *Soil Sci. Soc. Am. J.* 64: 346–358.
- Buerkert A., Bationo A. and Piepho H.P. 2001. Efficient phosphorus application strategies for increased crop production in sub-Saharan West Africa. *Field Crops Res.* 72: 1–15.
- Buerkert A., Piepho H.P. and Bationo A. 2002. Multi-site time trend analysis of soil fertility management effects on crop production in sub-Saharan West Africa. *Exp. Agric.* 38: 163–183.
- Buerkert A., Stern R.D. and Marschner H. 1995. Post-stratification clarifies treatment effects on millet growth in the Sahel. *Agron. J.* 87: 752–761.
- Dakora F.D. and Keya S.O. 1997. Contribution of legume nitrogen fixation to sustainable agriculture in sub-Saharan Africa. *Soil Biol. Biochem.* 29: 809–817.
- De Jager A., Kariuku I., Matiri F.M., Odendo M. and Wanyama J.M. 1998. Monitoring nutrient flows and economic performance in African farming systems (NUTMON) IV. Linking nutrient balances and economic performance in three districts in Kenya. *Agric. Ecosyst. Environ.* 71: 81–92.
- De Ridder N. and Van Keulen H. 1990. Some aspects of the role of organic matter in sustainable intensified arable farming systems in the West-African semi-arid-tropics (SAT). *Fert. Res.* 26: 299–310.
- De Ridder N., Breman H., Van Keulen H. and Stomph T.J. 2004. Revisiting a cure against land hunger: soil fertility management and farming systems dynamics in the West African Sahel. *Agric. Syst.* 80: 109–131.
- Dent J.B., Edwards-Jones G. and McGregor M.J. 1995. Simulation of ecological, social and economic factors in agricultural systems. *Agric. Syst.* 49: 337–351.
- Dommergues Y.R. and Ganry F. 1986. Biological nitrogen fixation and soil fertility maintenance. In: Mokwunye A.U. and Vlek P.L.G. (eds), *Management of Nitrogen and Phosphorus Fertilizers in sub-Saharan Africa*. Martinus Nijhoff Publishers, Dordrecht, The Netherlands, pp. 95–115.
- Dugué P. 1998. Gestion de la fertilité et stratégies paysannes. Le cas des zones de savanes d'Afrique de l'Ouest et du Centre. *Agric. Dévelop.* 18: 13–20.
- Esse P.C., Buerkert A., Hiernaux P. and Assa A. 2001. Decomposition of and nutrient release from ruminant manure on acid sandy soils in the Sahelian zone of Niger, West Africa. *Agric. Ecosyst. Environ.* 83: 55–63.

- Évéquoz M., Soumana D.K. and Yadjji G. 1998. Minéralisation du fumier, nutrition, croissance et rendement du mil planté dans des ouvrages anti-érosifs. In: Renard G., Neef A., Becker K. and Von Oppen M. (eds), Soil Fertility Management in West African Land Use Systems. Margraf Verlag, Weikersheim, Germany, pp. 203–208.
- Fatondji D. 2002. Organic amendment decomposition, nutrient release and nutrient uptake by millet (*Pennisetum glaucum* L. R. Br.) in a traditional land rehabilitation technique (zai) in the Sahel. PhD Thesis. University of Bonn, Germany. Cuvillier, Göttingen, Germany, 140 pp.
- Feller C. and Beare M.H. 1997. Physical control of soil organic matter dynamics in the tropics. *Geoderma* 79: 69–116.
- Feller C. and Milleville P. 1977. Evolution des sols de défriche récente dans la région des terres neuves (Sénégal oriental)/ 1ère partie: présentation de l'étude et évolution des principes caractéristiques morphologiques et physico-chimiques. *Cahiers ORSTOM, Sér. Biol. Agron.* 12: 199–211.
- Ferber J. 1999. Multi-Agent System: An Introduction to Distributed Artificial Intelligence. Addison-Wesley Longman, Harlow, USA, 528 pp.
- Fernández-Rivera S., Williams T.O., Hiernaux P. and Powell J.M. 1995. Faecal excretion by ruminants and manure availability for crop production in semi arid West Africa. In: Powell J.M., Fernández-Rivera S., Williams T.O. and Renard C. (eds), Livestock and Sustainable Nutrient Cycling in Mixed Farming Systems of Sub-Saharan Africa, Vol. 2. International Livestock Center for Africa, Addis Ababa, Ethiopia, pp. 149–170.
- Feuillette S., Bousquet F. and Goulven P.L. 2003. SINUSE: a multi-agent model to negotiate water demand management on a free access water table. *Environ. Model. Softw.* 18: 413–427.
- Florax R.J.G.M., Voortman R.L. and Brouwer J. 2002. Spatial dimensions of precision agriculture: a spatial econometric analysis of millet yield on Sahelian coversands. *Agric. Econ.* 27: 425–443.
- Friesen D.K. 1991. Fate and efficiency of sulphur fertilizer applied to food crops in West Africa. *Fert. Res.* 29: 35–44.
- Gandah M., Brouwer J., Van Duivenbooden N. and Hiernaux P. 2003. Fertility management and landscape position: farmers' use of nutrient sources in western Niger and possible improvements. *Nut. Cyc. Agroecosyst.* 67: 55–66.
- Gérard B. and Buerkert A. 1999. Aerial photography to determine fertiliser effects on pearl millet and *Guiera senegalensis* growth. *Plant Soil* 210: 167–178.
- Gérard B., Hiernaux P., Muehlig-Versen B. and Buerkert A. 2001. Destructive and non-destructive measurements of residual crop residue and phosphorus effects on growth and composition of herbaceous fallow species in the Sahel. *Plant Soil* 228: 265–273.
- Graef F. 1999. Evaluation of agricultural potentials in semi-arid SW-Niger: a soil and terrain (NISOTER) study. Hohenheimer Bodenkundliche Hefte 54, Hohenheim, Germany, 217 pp.
- Guerin V., Trinchant J.C. and Rigaud J. 1990. Nitrogen fixation (C₂H₂ reduction) by broad bean (*Vicia faba* L.) nodules and bacteroids under water-restricted conditions. *Plant Physiol.* 92: 595–601.
- Hafner H., George E., Bationo A. and Marschner H. 1993. Effect of crop residues on root growth and nutrient acquisition of pearl millet in an acid sandy soil in Niger. *Plant Soil* 150: 117–127.
- Hafner H., Ndunguru B.J., Bationo A. and Marschner H. 1992. Effect of nitrogen, phosphorus and molybdenum application on growth and symbiotic N₂ fixation of groundnut in an acid sandy soil in Niger. *Fert. Res.* 31: 69–77.
- Haigis J. 2000. Field management strategies used by rural households to combat decreasing soil fertility. In: Graef F., Lawrence P. and Von Oppen M. (eds), Adapted Farming in West Africa: Issues, Potentials and Perspectives. Verlag Ulrich E. Grauer, Stuttgart, Germany, pp. 185–200.
- Haigis J. 2004. Sozio-ökonomische Beurteilung von Innovationen: Untersuchungen über die Innovationenakzeptanz auf Betriebs-Haushaltsebene in Niger. PhD Thesis. University of Hohenheim, Germany.
- Haigis J., Wezel A., Rath T., Graef F., Muehlig-Versen B., Abele S., Frick T. and Neef A. 1998. An interdisciplinary approach to evaluate technology options for small scale farming in Niger. In: Lawrence P., Renard G. and Von Oppen M. (eds), The Evaluation of Technical and Institutional Options for Small Farmers in West Africa. Margraf Verlag, Weikersheim, Germany, pp. 23–40.
- Harris F.M.A. 1998. Farm-level assessment of nutrient balance in northern Nigeria. *Agric. Ecosyst. Environ.* 71: 201–214.
- Harris F. 2000. Changes in soil fertility under indigenous agricultural intensification in the Kano region. Working Paper 36. Drylands Research, Crewkerne, Somerset, UK, 43 pp.
- Harris F. 2002. Management of manure in farming systems in semi-arid West Africa. *Expl. Agric.* 38: 131–148.
- Hengsdijk H. and Kruseman G. 1992. Operationalizing the DLV program: an integrated agro-economic and agro-ecological approach to a methodology for analysis of sustainable land use and regional agricultural policy. Report 1, DLV-DLO, Wageningen, The Netherlands.
- Hengsdijk H. and Van Keulen H. 2002. The effect of temporal variation on inputs and outputs of future-oriented land use systems in West Africa. *Agric. Ecosyst. Environ.* 91: 245–259.
- Herrmann L. 1996. Staubdeposition auf Boeden West-Afrikas. Eigenschaften und Herkunftsgebiete der Stäube und ihr Einfluss auf Boden und Standortseigenschaften, Hohenheimer Bodenkundliche Hefte 36. University of Hohenheim, Stuttgart, Germany, 239 pp.
- Herrmann L., Bleich K.E. and Stahr K. 1993. Veränderung eines landwirtschaftlich genutzten Standortes in Niger/Westafrica durch Staubeintrag. *Mitt. Deutsch. Bodenk. Gesellschaft* 72: 927–930.
- Hien F.G., Singerland M. and Hien V. 1998. Le paillage traditionnel dans la gestion de la fertilité des sols en milieu soudano-sahélien: fonctions biophysiques et incidence sur la production de sorgho. In: Renard G., Neef A., Becker K. and Von Oppen M. (eds), Soil Fertility Management in West African Land Use Systems. Margraf Verlag, Weikersheim, Germany, 539 pp.
- Hoffmann I., Gerling D., Kyiogwom U.B. and Mané-Bielfeldt A. 2001. Farmers' management strategies to maintain soil fertility in a remote area in northwest Nigeria. *Agric. Ecosyst. Environ.* 86: 263–275.
- Hoogmoed W.B. and Stroosnijder L. 1984. Crust formation on sandy soils in the Sahel. I. Rainfall and infiltration. *Soil Till. Res.* 4: 5–23.

- Ikpe F.N., Powell J.M., Isirimah N.O., Wahua T.A.T. and Ngodigha E.M. 1999. Effects of primary tillage and soil amendment practices on pearl millet yield and nutrient uptake in the Sahel of West Africa. *Exp. Agric.* 35: 437–448.
- Jansen H.G.P. 1993. *Ex-ante* profitability of animal traction investments in semiarid sub-Saharan Africa: evidence from Niger and Nigeria. *Agric. Syst.* 43: 323–349.
- Kang B.T. 1997. Alley cropping – soil productivity and nutrient recycling. *Forest. Ecol. Manage.* 91(1): 75–82.
- Keating B.A., Carberry P.S., Hammer G.L., Probert M.E., Robertson M.J., Holzworth D., Huth N.I., Hargreaves J.N.G., Meinke H., Hochman Z., McLean G., Verburg K., Snow V.O., Dimes J.P., Silburn M., Wang E., Brown S., Bristow K.L., Asseng S., Chapman S.C., McCown R.L., Freebairn D.M. and Smith C.J. 2003. An overview of APSIM, a model designed for farming systems simulation. *Eur. J. Agron.* 18: 267–288.
- Klajj M.C. and Hoogmoed W.B. 1989. Crop response to tillage practices in a Sahelian soil. In: *Soil, Crop and Water Management in the Sudano-Sahelian Zone*, Proceedings of an international workshop, ICRISAT Sahelian Center, Niamey, Niger, January 11–16, 1987. ICRISAT, Patancheru, pp. 265–275.
- Kretschmar R.M., Hafner H., Bationo A. and Marschner H. 1991. Long- and short-term effects of crop residues on aluminium toxicity, phosphorus availability and growth of pearl millet in an acid sandy soil. *Plant Soil* 136: 215–223.
- Krogh L. 1997. Field and village nutrient balances in millet cultivation in northern Burkina Faso: a village case study. *J. Arid Environ.* 35: 147–159.
- Kruseman G. 2000. Bio-economic modelling for agricultural intensification. Ph.D. Thesis, University of Wageningen, The Netherlands.
- La Rovere R. 2001. Livestock roles and agro-environmental sustainability of Sahelian Niger mixed crop–livestock systems under intensification. Ph.D. Thesis, University of Bologna, Italy.
- Lamers J.P.A. and Feil P.R. 1993. The many uses of millet crop residues. *ILEIA Newslett.* 9: 15.
- Lamers J.P.A. and Feil P.R. 1995. Farmers' knowledge and management of spatial soil and crop growth variability in Niger, West Africa. *Neth. J. Agric. Sci.* 43: 375–389.
- Lamers J.P.A., Becker T. and Von Oppen M. 1996. Arrangements to finance tree windbreaks for wind erosion control. In: Buerkert B., Allison B.E. and Von Oppen (eds), *Wind Erosion in West Africa: The Problem and its Control*. Margraf Verlag, Weikersheim, Germany, pp. 227–241.
- Lamers J., Bruentrup M. and Buerkert A. 1998. The profitability of traditional and innovative mulching techniques using millet crop residues in the West African Sahel. *Agric. Ecosyst. Environ.* 67: 23–35.
- Lamers J.P.A., Feil P.R. and Buerkert A. 1995. Spatial crop growth variability in Western Niger: the knowledge of farmers and researchers. *Ind. Knowledge Develop. Monit.* 3(3): 17–19.
- Leihner D.E., Buerkert A., Banzhaf J. and Serafini P.G. 1993. Soil tillage and windbreak effects on millet and cowpea. II. Dry matter and grain yield. *Agron. J.* 85: 400–405.
- Lose S.J., Hilger T.H., Leihner D.E. and Kroschel J. 2003. Cassava, maize and tree root development as affected by various agroforestry and cropping systems in Benin, West Africa. *Agric. Ecosyst. Environ.* 100(23): 137–151.
- Manlay R.J., Ickowicz A., Masse D., Feller C. and Richard D. 2004. Spatial carbon, nitrogen and phosphorus budget in a village of the West African savanna. II. Element flows and functioning of a mixed farming system. *Agric. Syst.* 79: 83–107.
- Marschner P., Joergensen R.G., Piepho H.P. and Buerkert A. 2004. Legume rotation effects on early growth and rhizosphere microbiology of sorghum in West African soils. *Plant Soil* 264: 325–334.
- Mazzucato V. and Niemeijer D. 2001. Overestimating land degradation, underestimating farmers in the Sahel. *Drylands Issue Papers* 101, IIED, London, UK, 22 pp.
- McIntire J., Bourzat D. and Pingali P. 1992. Crop–Livestock Interaction in Sub-Saharan Africa. World Bank Regional and Sectoral Studies, World Bank, Washington.
- Mertz O. and Reenberg A. 1999. Building on diversity: pathways to agricultural intensification in Burkina Faso. *Dan. J. Geogr.*, Special issue 2: 125–137.
- Michels K., Lamers J.P.A. and Buerkert A. 1998. Effects of windbreak species and mulching on wind erosion and millet yield in the Sahel. *Exp. Agric.* 34: 449–464.
- Michels K., Sivakumar M.V.K. and Allison B.E. 1995a. Wind erosion control using crop residue: I. Effects on soil flux and chemical properties. *Field Crop. Res.* 40: 101–110.
- Michels K., Sivakumar M.V.K. and Allison B.E. 1995b. Wind erosion control using crop residue II. Effects on millet establishment and yields. *Field Crop. Res.* 40: 111–118.
- Mokwunye A.U. 1995. The new World Bank initiative: use of phosphorus and in particular of phosphate rock as an investment in natural resource capital in sub-Saharan Africa. In: Gerner H. and Mokwunye A.U. (eds), *Use of Phosphate Rock for Sustainable Agriculture in West Africa*. IFDC-Africa, Lomé, Togo.
- Mokwunye A.U., De Jager A. and Smaling E.M.A. 1996. Restoring and maintaining the productivity of West African soils: key to sustainable development. International Fertilizer Development Centre, Lomé, Togo, 94 pp.
- Mortimore M., Tiffen M., Boubacar Y. and Nelson J. 2001. Synthesis of long-term change in Maradi department, Niger, 1960–2000. Working paper 39e, Drylands Research, Crewkerne, Somerset, UK, 60 pp.
- Muehlig-Versen B., Buerkert A., Bationo A. and Römhild V. 2003. Phosphorus placement on acid Arenosols of the Sahel. *Exp. Agric.* 39: 307–325.
- Mughogho S.K., Bationo A., Christianson B. and Vlek P.L.G. 1986. Management of nitrogen fertilizers for tropical African soils. In: Mokwunye A.U. and Vlek P.L.G. (eds), *Management of Nitrogen and Phosphorus Fertilizers in Sub-Saharan Africa*. Martinus Nijhoff Publishers, The Hague, The Netherlands, pp. 117–172.
- Neef A. 1999. Auswirkungen von Bodenrechtswandel auf Ressourcennutzung und wirtschaftliches Verhalten von Kleinbauern in Niger und Benin. (Development Economics and Policy, Vol. 12) Frankfurt am Main and Berlin, Lang, 290 pp.
- Nicou R. and Charreau C. 1985. Soil tillage and water conservation in semi-arid West Africa. In: Ohm H. and Nagy J.G. (eds), *Appropriate Technologies for Farmers in Semi-arid West Africa*. Purdue University Press, West Lafayette, pp. 9–32.
- Osbahr H. and Allen C. 2003. Indigenous knowledge of soil fertility management in southwest Niger. *Geoderma* 111(3–4): 457–479.

- Ouedraogo E., Mando A. and Zombré N.P. 2001. Use of compost to improve soil properties and crop productivity under low input agricultural system in West Africa. *Agric. Ecosyst. Environ.* 84: 259–266.
- Pankhurst C.E. and Sprent J.I. 1975. Surface feature of soybean root nodules. *Protoplasma* 85: 85–98.
- Penning de Vries F.W.T. and Djitéye M.A. 1982. La productivité des pâturages Sahéliens. Une étude des sols, des végétations et de l'exploitation de cette ressource naturelle. *Agric. Res. Rep.* 918, Pudoc, Wageningen, The Netherlands.
- Piéri C. 1986. Fertilisation des cultures vivrières et fertilité des sols en agriculture paysanne subsaharienne. *Agron. Trop.* 41: 1–20.
- Powell J.M. and Unger P.W. 1998. Alternatives to crop residues for sustaining agricultural productivity and natural resource conservation. *J. Sust. Agric.* 11(2–3): 59–84.
- Powell J.M., Ikpe F.N. and Somda Z.C. 1999. Crop yield and the fate of nitrogen and phosphorus following application of plant material and feces to soil. *Nutr. Cycl. Agroecosyst.* 54: 215–226.
- Powell J.M., Fernandez-Rivera S. and Höfs S. 1994. Effects of sheep diet on nutrient cycling in mixed farming systems of semi-arid West Africa. *Agric. Ecosyst. Environ.* 48: 263–271.
- Powell J.M., Fernandez-Rivera S., Hiernaux P. and Turner M. D. 1996. Nutrient cycling in integrated rangeland/cropland systems of the Sahel. *Agric. Syst.* 52: 143–170.
- Powell J.M., Ikpe F.N., Somda Z.C. and Fernández-Rivera S. 1998. Urine effects on soil chemical properties and the impact of urine and dung on pearl millet yield. *Exp. Agric.* 34: 259–276.
- Poulain J.F., Doumbia A., Franc M., Jenny F., Pieri C., Thibout F. and Traoré M.-F. 1974. Amélioration de la fertilité des sols agricoles du Mali Bilan de treize années de travaux (1962–1974). *Agron. Trop.* 31: 403–416.
- Rajot J.L. 2001. Wind blown sediment mass budget of Sahelian village land units in Niger. *Bull. Soc. Géol. Fr.* 5: 523–531.
- Rebafka F.P., Bationo A. and Marschner H. 1993a. Phosphorus seed coating increases P uptake, early growth and yield of pearl millet (*Pennisetum glaucum* (L.) R. Br.) grown on an acid sandy soil in Niger, West Africa. *Fert. Res.* 35: 151–160.
- Rebafka F.P., Bationo A. and Marschner H. 1993b. Single superphosphate depresses molybdenum uptake and limits yield response to phosphorus in groundnut (*Arachis hypogaea* L.) grown on an acid sandy soil in Niger, West Africa. *Fert. Res.* 34: 233–242.
- Rebafka, F.P., Hebel A., Bationo A., Stahr K. and Marschner H. 1994. Short- and long-term effects of crop residues and of phosphorus fertilization on pearl millet yield on an acid sandy soil in Niger, West Africa. *Field Crop. Res.* 36: 113–124.
- Renard C., Boudouresque E., Schmelzer G. and Bationo A. 1993. Evolution de la végétation dans une zone protégée du Sahel (Sadoré, Niger). ICRISAT, Niamey, Niger. In: Floret C. and Serpantié G. (eds), *La Jachère en Afrique de l'Ouest*. ORSTOM, Collection Colloques et Séminaires, Paris, France, pp. 297–306.
- Ruben R. and Van Ruijven A. 2001. Technical coefficients for bio-economic farm household models: a meta-modelling approach with applications for Southern Mali. *Ecol. Econ.* 36: 427–441.
- Ruben R., Moll H. and Kuyvenhoven A. 1998. Integrating agricultural research and policy analysis: analytical framework and policy applications for bio-economic modelling. *Agric. Syst.* 58: 331–349.
- Schlecht E. 1995. The influence of supplementation on feed intake and nutrient retention of grazing Zebu Cattle in Sahelian agro-pastoral systems. Ph.D. Thesis, University of Hohenheim, Germany. C. Shaker, Aachen, Germany, 200 pp.
- Schlecht E. and Buerkert A. 2004. Organic inputs on millet fields in western Niger: the implications of farmers' practices for sustainable agricultural production. *Geoderma* 121: 271–289.
- Schlecht E. and Hiernaux P. 2004. Beyond adding up inputs and outputs: process assessment and upscaling in modelling nutrient flows. *Nutr. Cycl. Agroecosyst.* 70: 303–319.
- Schlecht E., Fernández-Rivera S. and Hiernaux P. 1998. Timing, size and N-concentration of faecal and urinary excretions in cattle, sheep and goats – can they be used for better manuring of cropland?. In: Renard G., Neef A., Becker K. and Von Oppen M. (eds), *Soil Fertility Management in West African Land Use Systems*. Margraf Verlag, Weikersheim, Germany, pp. 361–368.
- Schlecht E., Hiernaux P., Achard F. and Turner M.D. 2004. Livestock related nutrient budgets within village territories in western Niger. *Nutr. Cycl. Agroecosyst.* 68: 199–211.
- Schlecht E., Mahler F., Sangaré M., Susenbeth A. and Becker K. 1995. Quantitative and qualitative estimation of nutrient intake and faecal excretion of zebu cattle grazing natural pasture in semi-arid Mali. In: Powell J.M., Fernández-Rivera S., Williams T.O. and Renard C. (eds), *Livestock and Sustainable Nutrient Cycling in Mixed Farming Systems of Sub-Saharan Africa Proceedings of an International Conference*, Vol. II, Technical Papers. International Livestock Centre for Africa, Addis Ababa, Ethiopia, pp. 85–97.
- Scoones I. and Toulmin C. 1998. Soil nutrient budgets and balances: what use for policy? *Agric. Ecosyst. Environ.* 71: 255–269.
- Scoones I. and Toulmin C. 1999. Policies for Soil Fertility Management in Africa: A Report Prepared for the Department for International Development. International Institute for Environment and Development, Russell Press, Nottingham, England, 128 pp.
- Shepherd K.D. and Soule M.J. 1998. Soil fertility management in west Kenya: dynamic simulation of productivity, profitability and sustainability at different resource endowment levels. *Agric. Ecosyst. Environ.* 71: 131–145.
- Sinaj S., Buerkert A., El-Hajj G., Bationo A., Traoré H. and Frossard E. 2001. Effects of fertility management strategies on phosphorus bioavailability in four West African soils. *Plant Soil* 233: 71–83.
- Sissoko K. 1998. Et demain l'Agriculture? Options Techniques et Mesures Politiques pour un Développement Agricole Durable en Afrique Subsaharienne: Cas du Cercle de Koutiala en Zone Sud du Mali. Ph.D. Thesis, University of Wageningen, The Netherlands.
- Slingerland M. and Masdewel M. 1996. Le paillage sur le plateau central du Burkina Faso: une technique très utilisée et bien adaptée aux moyens des paysans. In: Reij C., Scoones I. and Toulmin C. (eds), *Techniques Traditionnelles de Conservation de l'Eau et des Sols en Afrique*. CTA, Wageningen, CDCS, Amsterdam, Karthala, Paris, pp. 127–132.

- Smaling E.M.A., Fresco L.O. and De Jager A. 1996. Classifying, monitoring and improving soil nutrient stocks and flows in African agriculture. *Ambio* 25: 492–496.
- Smith D.M., Jarvis P.G. and Odongo J.C.W. 1997. Energy budgets of windbreak canopies in the Sahel. *Agric. Forest Meteorol.* 86: 33–49.
- Somda Z.C. and Powell J.M. 1998. Seasonal decomposition of sheep manure and forage leaves in soil. *Commun. Soil. Sci. Plant Anal.* 29(19–20): 2961–2979.
- Somda Z.C., Powell J.M., Fernández-Rivera S. and Reed J. 1995. Feed factors affecting nutrient excretion by ruminants and the fate of nutrients when applied to soil. In: Powell J.M., Fernández-Rivera S., Williams T.O. and Renard C. (eds), *Livestock and Sustainable Nutrient Cycling in Mixed Farming Systems of Sub-Saharan Africa*, Vol. 2. ILCA, Addis Ababa, Ethiopia, pp. 227–243.
- Sterk G. and Haigis J. 1998. Farmers' knowledge of wind erosion processes and control methods in Niger. *Land Degrad. Dev.* 9: 107–114.
- Sterk G., Herrmann L. and Bationo A. 1996. Wind-blown nutrient transport and soil productivity changes in southwest Niger. *Land Degrad. Dev.* 7: 325–335.
- Stevenson F.J. and Cole M.A. 1999. The internal cycle of nitrogen in soil. In: Stevenson F.L. and Cole M.A. (eds), *Cycles of Soils: Carbon, Nitrogen, Phosphorus, Sulfur, Micronutrients*, 2nd edn. John Wiley & Sons, Inc., pp. 191–229.
- Stoorvogel J.J. and Antle J.M. 2001. Regional land use analysis: the development of operational tools. *Agric. Syst.* 70: 623–640.
- Stoorvogel J.J. and Smaling E.M.A. 1990. Assessment of soil nutrient depletion in sub-Saharan Africa: 1983–2000. Vol. 1. Main Report. DLO – Winand Staring Centre, Wageningen, The Netherlands, 137 pp.
- Stoorvogel J.J., Schipper R.A. and Jansen D.M. 1995. USTED: a methodology for a quantitative analysis of land use scenarios. *Neth. J. Agric. Sci.* 43: 5–18.
- Stoorvogel J.J., Smaling E.M.A. and Janssen B.H. 1993. Calculating soil nutrient balances in Africa at different scales. I. Supra-national scale. *Fert. Res.* 35: 227–335.
- Struif Bontkes T.E. 1999. Modelling dynamics of agricultural development: a process approach – the case of Koutiala (Mali). Ph.D. Thesis. Wageningen Agricultural University, Wageningen, The Netherlands.
- Subbarao G.V., Renard C., Payne W.A. and Bationo A. 2000. Long-term effects of tillage, phosphorus fertilization and crop rotation on pearl millet-cowpea productivity in the West-African Sahel. *Exp. Agric.* 36: 243–264.
- Sumberg J. 2002. The logic of fodder legumes in Africa. *Food Policy* 27: 285–300.
- Thomas D. and Sumberg J.E. 1995. A review of the evaluation and use of tropical forage legumes in sub-Saharan Africa. *Agric. Ecosyst. Environ.* 54: 151–163.
- Tian G., Kang B.T. and Kolawole G.O. 2003. Effect of fallow on pruning biomass and nutrient accumulation in alley cropping on alfisols of tropical Africa. *J. Plant Nutr.* 26(3): 475–486.
- Tiffen M., Mortimore M. and Gichuki F. 1994. *More People Less Erosion: Environmental Recovery in Kenya*. John Wiley, London, 311 pp.
- Van den Bosch H., De Jager A.A. and Vlaming J. 1998. Monitoring nutrient flows and economic performance in African farming systems (NUTMON) II. Tool development. *Agric. Ecosyst. Environ.* 71: 49–62.
- Van der Pol F. 1992. *Soil Mining An Unseen Contributor to Farm Income in Southern Mali*. Royal Tropical Institute Bulletin 325, KIT, Amsterdam, The Netherlands.
- Van Duivenbooden N. 1993. Impact of inorganic fertilizer availability on land use and agricultural production in the Fifth Region of Mali. II. Scenario definition and results. *Fert. Res.* 35: 205–216.
- Van Duivenbooden N. and Veeneklaas F.R. 1993. Impact of inorganic fertilizer availability on land use and agricultural production in the Fifth Region of Mali. I. Methodology and basic data. *Fert. Res.* 35: 193–204.
- Van Ittersum M.K., Leffelaar P.A., Van Keulen H., Kropff M.J., Bastiaans L. and Goudriaan J. 2003. On approaches and applications of the Wageningen crop models. *Eur. J. Agron.* 18: 201–234.
- Van Keulen H. and Breman H. 1990. Agricultural development in the West African Sahelian region: a cure against land hunger. *Agric. Ecosyst. Environ.* 32: 177–197.
- Warren A. 2002. Land degradation is contextual. *Land Degrad. Dev.* 13: 449–459.
- Wezel A. and Boecker K. 1998. Indigenous shrubs as an agroforestry component in millet fields in semi-arid Niger. In: Renard G., Neef A., Becker K. and Von Oppen M. (eds), *Soil Fertility Management in West African Land Use Systems*. Margraf Verlag, Weikersheim, Germany, pp. 305–309.
- Wezel A. and Boecker R. 1999. Mulching with branches of an indigenous shrub (*Guiera senegalensis*) and yield of millet in semi-arid Niger. *Soil Till. Res.* 50: 341–344.
- Wezel A. and Haigis J. 2002. Fallow cultivation system and farmers' resource management in Niger, West Africa. *Land Degrad. Dev.* 13: 221–231.
- Williams T.O., Powell J.M. and Fernández-Rivera S. 1995. Manure utilisation, drought cycles and herd dynamics in the Sahel: implications for cropland productivity. In: Powell J.M., Fernández-Rivera S., Williams T.O. and Renard C. (eds), *Livestock and Sustainable Nutrient Cycling in Mixed Farming Systems of sub-Saharan Africa*, Vol. II: Technical Papers. Proceedings of an International Conference held in Addis Ababa, Ethiopia, 22–26 November 1993, pp. 393–409.
- Yamoah C.F., Bationo A., Shapiro B. and Koala S. 2002. Trend and stability analyses of millet yields treated with fertilizer and crop residues in the Sahel. *Field Crop. Res.* 75: 53–62.

Appropriate technologies to replenish soil fertility in southern Africa

P. L. Mafongoya · A. Bationo · J. Kihara ·
B. S. Waswa

Abstract In southern Africa, soil nutrient reserves are being depleted because of continued nutrient mining without adequate replenishment. The consequent downward spiral of soil fertility has led to a corresponding decline in crop yields, food insecurity, food aid and environmental degradation. The central issue for improving agricultural productivity in southern Africa is how to build up and maintain soil fertility despite the low incomes of smallholder farmers and the increasing land and labour constraints they face. Under this review five main options namely: inorganic fertilizers, grain legumes, animal manures, integrated nutrient management and agroforestry options appropriate to smallholder farmers are presented. Issues addressed in the use of inorganic fertilizers are reduction in

fertilizer costs, timely availability and use efficiency. Legumes can be used to diversify farm system productivity but this requires P and lime application to support better legume growth and biological nitrogen fixation (BNF) as well as development of markets for various legume products. Manure availability and quality are central issues in increasing smallholder farm productivity and increasing its efficiency through proper handling and application methods. Integrated nutrient management of soil fertility by combined application of both inputs will increase use efficiency of inputs and reduce costs and increase profitability; but the challenge is often how to raise adequate amounts of either inorganic or organic inputs. Issues such as quality of inputs, nutrient balancing, labour to collect and transport organic inputs and their management need to be optimized. These are the challenges of adoption as are the scaling up of these options to millions of small-scale farmers.

P. L. Mafongoya (✉)
ICRAF, Zambia Senior Soil Scientist,
PO Box 510089, Chipata, Zambia
e-mail: mafongoya@zamnet.zm

A. Bationo · J. Kihara · B. S. Waswa
Tropical Soil Biology and Fertility Institute of CIAT
(TSBF-CIAT), PO Box 30677-00100, Nairobi, Kenya

A. Bationo
e-mail: a.bationo@cgiar.org

J. Kihara
e-mail: j.kihara@cgiar.org

B. S. Waswa
e-mail: b.waswa@cgiar.org

Keywords Agroforestry · Grain legumes ·
Inorganic fertilizers · Integrated nutrient
management and Organic inputs

Introduction

Low soil fertility is increasingly recognized as a fundamental biophysical cause for declining food

This article has been previously published in the journal "Nutrient Cycling in Agroecosystems" Volume 76 Issues 2–3.

security among small-farm households in sub-Saharan Africa (SSA) (Sanchez et al. 1997). At present, aggregate maize yield in southern Africa is about 1.0 t ha⁻¹ excluding South Africa. In most cases, nitrogen is the main nutrient that limits maize productivity, with phosphorus and potassium being occasional constraints. Low nutrient holding capacities, high acidity, low organic matter, poor soil structure and low water-holding capacity are other constraints to soil productivity. These constraints are in some cases exacerbated by over exploitation through continuous cropping and low nutrient application rates. Stoorvogel et al. (1993) estimated annual nitrogen losses from arable land to be 31 kg ha⁻¹ in Zimbabwe and 68 kg ha⁻¹ in Malawi. Swaziland, Mozambique and Madagascar have annual NPK losses >60 kg ha⁻¹ with Lesotho falling somewhere between 30 and 60 kg ha⁻¹ (Nandwa, 2003). The estimates of nutrient mining for some South African countries reported by (Henao and Baanante 1999) reflect similar losses (Table 1). Traditionally maintenance of soil fertility in agricultural systems relied largely on bush fallows (Blackie and Jones 1993). Today, fallowing in arable areas of Malawi, Zimbabwe and other countries has almost disappeared and continuous cropping is the norm. In Zambia and Mozambique where fallowing is still widely practiced, the length of the fallow period is decreasing and often insufficient to maintain soil fertility.

The critical issue for improving agricultural productivity in southern Africa is how to build up and maintain soil fertility despite low incomes, increasing labour and land constraints faced by smallholder farmers (Kumwenda et al. 1997).

Table 1 Annual nutrient depletion in agricultural soils in countries of Southern Africa

Country	Nutrient depletion (kg ha ⁻¹ year ⁻¹)			Total fertilizer use (kg ha ⁻¹)
	N	P	K	
Tanzania	-38	-6	-25	4.5
Malawi	-48	-7	-37	14.6
Mozambique	-23	-4	-19	3.5
Zambia	-13	-1	-12	5.7
Zimbabwe	-20	-1	-21	49.3

Source: Henao and Baanante (1999)

(FAO 2003)

Following research from the 1950s, approaches for soil fertility replenishment have been proposed and these range from recurring fertilizer applications to low external input agriculture based on organic sources of nutrients. Although the strategies work well in specific circumstances, they pose major limitations for most smallholder farmers in southern Africa. In this review the focus is on some of the options which are appropriate and available to farmers namely: inorganic fertilizers, animal manures, grain legumes, agroforestry options, and integrated nutrient management options. The socio-economic challenges and constraints that limit the adoption of these options are also presented.

Inorganic fertilizer inputs and their management

Fertilizer use has been responsible for a large part of sustained increases in per capita food production that have occurred in Asia, Latin America as well as for commercial farmers in southern Africa (Sanchez et al. 1997). However, although most small-scale farmers in southern Africa appreciate the value of fertilizers they rarely apply them at the recommended rates and at the appropriate time because of high cost (Kazombo-Phiri 2005), lack of credit, delivery delays and low and variable returns (Heisey and Mwangi 1996). The high prices prohibit fertilizer use among subsistence farmers (Kazombo-Phiri 2005). Such constraints are likely due to lack of enabling policy environment in rural areas aggravated by poor market infrastructure.

Since the 1960s fertilizer use has been growing in SSA at around 6.7% annually but growth in application rates per hectare has slowed down since the 1990s. In Southern Africa, current fertilizer use varies from 3.5 kg ha⁻¹ in Mozambique to 49.3 kg ha⁻¹ in Zimbabwe as compared to 80 kg ha⁻¹ year⁻¹ in the rest of the world. According to Ahmed et al. (1997) and Rusike et al. (2003) as quoted by ICRISAT (2006) <5% of farmers commonly use fertilizers in Zimbabwe for instance and this is due to the fear to risk investment in fertilizer. Recent estimates showed that a little over one-third of the maize, the most important staple food in the southern Africa region receives some inorganic fertilizers. Much less is applied for

Table 2 Nitrogen maize price ratio of some countries in southern Africa and other developing region

Country or Region	Nitrogen maize price ration
Malawi	7.7
Zimbabwe	6.4
Mozambique	4.3
Zambia	5.4
Lesotho	4.8
Swaziland	4.9
Asia	2.7
Latin America	3.8

Source: Waddington and Heisey (1996)

other crops. One of the main factors underlying low fertilizer use in southern Africa is the relatively high nutrient to grain price ratio (Table 2). High price ratios lead to unfavorable benefit cost ratios. For example, the benefit: cost ratio in Malawi is 1.8 for fertilizer use on hybrid maize (Conroy and Kumwenda 1995) and this is substantially below the ratio 2.0 usually assumed necessary for widespread adoption of fertilizer by smallholder farmers. Greater variability in policy, prices and climate especially in drier areas increase the risk of fertilizer use in southern Africa compared with Asia and other parts of the world. There is therefore a need to improve fertilizer use efficiency so that the use of fertilizer is financially attractive to farmers and thus expand its use.

Low fertilizer use efficiency also reflects inappropriate fertilizer recommendations promoted by research and extension services. For >50 years research on inorganic fertilizers in Zimbabwe and Malawi was geared towards commercial farmers who could afford large amounts of fertilizers on commercial crops. Thus, researchers have often ignored climatic and soil conditions of small-scale farmers in most southern Africa countries. For instance, although work has been done since independence on appropriate types, amounts, timing and placement of inorganic fertilizers for food crops produced by smallholder farmers (Hikwa and Mukurumbira 1995) fertilizer recommendations in Zimbabwe and other countries still fail to take sufficient account of cash constraints and risks affecting resource poor farmers in marginal areas. Recent work in the region to tailor inorganic fertilizers types, amounts, timing and placement to the conditions under which smallholder farmers

produce maize and other cash crops is yet to be used in fertilizer recommendations. In Malawi for example, recommendations for improving maize yield include supplementation of basal NP fertilizer with Zn and S, reduction in P application rates, band application of basal and top dress fertilizer (compared with the current method), and earlier application of basal fertilizer and top dress N fertilizer (Jones and Wendt 1995; Kumwenda et al. 1995). Kumwenda et al. (1995) already showed that Zn and S supplementation targeted to deficient soils improved N fertilizer efficiency and increased maize yields by 40% over standard NP recommendations alone. Similarly, in Zimbabwe all compound fertilizers must contain S, Zn or Boron by law to deal with similar deficiencies.

Limited soil moisture in the drier areas is a frequent constraint to maize production and response to fertilizer application. Existing fertilizer recommendations are too risky in these areas and need to be adjusted to evolving rainfall pattern in order to increase their profitability (Piha 1993). An experiment on adjusting fertilizer recommendations to respond to rainfall in Zimbabwe gave 25–42% more yield and 21–41% more profit than existing application recommendations. By concentrating fertilizer applications in basins ('potholes'), along with liming and emphasis on timely planting and weeding, the maize yield of farmers practicing conservation farming has been raised from 1 t ha⁻¹ to six or more. But the general fertilizer recommendations prove the best options compared to common farmer practices in the absence of area specific recommendations (Sakala 1996) indicating that these general recommendations may not be completely irrelevant.

The use of small quantities of fertilizer for crop production was assessed during the 1990s based on the premise that farmers may initiate investments in small quantities of fertilizer. The results suggest that farmers could increase their average yields by 50–100% by applying as little as 9 kg N ha⁻¹ directly to the base of the plant (ICRISAT 2006). The response depends on the rainfall received, crop grown and the zone. According to Bwalya (2005), success in increasing yields will also depend on improved access to seed besides fertilizer inputs.

The challenge of generating and availing fertilizer technology and knowledge that are usable and affordable to small scale farmers must consider the diversity of the southern Africa agro-ecosystems. For instance, within-field and within-farm variabilities are sometimes greater than mean differences across districts and have potentially profound effects for extension recommendations (Carter and Murwira, 1995). The diversity of farmer reality, including access to resources implies that solutions need to be site-specific and requires emphasis on farmer experimentation and participatory learning, and building of partnerships between stakeholders (farmers, credit providers, input dealers, research and extension agencies, government) at village, regional, and national levels. This will require clear understanding of the socioeconomic contexts/constraints of farmers, agro-dealers, private and public sectors across regions in southern Africa, and identification of opportunities and constraints for increasing fertilizer use. These constraints include limited access to credit, poor infrastructure in rural areas, high risks and transaction costs of distant markets, weak purchasing power of the poor farmers, limited access to fertilizer information among the poor, limited number of trained rural fertilizer stockists, lack of inputs in affordable sizes, low and irregular supply of inputs, lack of appropriate fertilizers fit for local conditions among others.

Use of animal manures

Animal manure is an important soil fertility replenishment component in the mixed crop-livestock farming systems that are characteristic of Southern Africa. Animal manure has traditionally been used as a source of nutrients and can improve crop yields considerably. This has been shown in several studies and reviews (Probert et al. 1995; Haque 1993; Murwira et al. 1995). Murwira et al. (2002) observed per cent fertilizer equivalencies of manure across four sites in Zimbabwe to vary between 10 and 35%. In some cases, a yield reduction is observed when N-poor manure is applied due to immobilization effect when the C:N ratio is greater than 23. Within Fundikila (grass-mound) system in Zambia, there

was no difference in finger millet yield between grass mounds only treatment and grass-mounds plus kraal manure treatment and this was due to N immobilization effect from poor quality grass (Goma, 2003). Other demonstrated benefits of manure include increase in soil pH, water holding capacity, hydraulic conductivity and infiltration rate and decreased bulk density. Manure can be an important source of nutrients, especially nitrogen (N), phosphorus (P) and potassium (K). In Zimbabwe, for instance, estimates from the Mutoko communal area suggest that over 80% of the N applied to field and garden crops is derived from kraal manure and about 10% from leaf litter (Scoones and Toulmin 1985).

Quantity and quality of manure

Inadequate availability of manure is a problem faced by farmers in southern Africa. The amount of manure available to a farmer is dependent on several factors such as breed, herd size, management system and seasonal rainfall conditions. Probert et al. (1995) estimated manure production levels of 1 t per livestock unit per year for unimproved local cattle breed in maize-livestock system in the semi-arid parts of eastern Kenya. Similar production levels have been reported in Zimbabwe. According to Murwira et al. (2004), farmers value manure quantity as being more important than quality and farmers usually augment quantity by adding anthill soil, crop residues and leaf litter. But not all farmers with cattle use manure in crop production. In Zimbabwe, 60% of households owning cattle did not use cattle manure as an amendment for crop production (ICRISAT 2006).

In spite of the low levels of manure production, recommended manure application levels are often as high as 10–15 t ha⁻¹ year⁻¹ (Grant 1981) and sometimes upto 40 t ha⁻¹ (Murwira et al. 1995). The manure used in trials where the recommendations are drawn often emanates from feedlots and ranches with higher feed quality than communal areas. The quality of kraal manure from livestock in communal areas is highly variable, with N levels as percentage of dry matter (DM) ranging from 0.46 to 1.98% (Tanner and Mugwira 1984; Mugwira and Mukurumbira 1985; Mureithi

et al. 1994). The effectiveness of manure depend on its N content and the application rate (Murwira et al. 1995) yet nutrient content data is often not cited and quality varies considerably from farmer to farmer (Murwira 2003). For high yielding maize crops, manure alone is unable to supply continuously large amounts of readily available N especially in clay soils where mineralization is often lower than in sandy soils due to its shielding effect (Murwira et al. 1995). The P concentration also can vary greatly depending on the source, the diet of the animal, storage and management (Guar et al. 1984) but quite often, its supply is low requiring supplementary P fertilizer application (Murwira et al. 1995). Additionally, communal area cattle manure contains high fractions of sand due to the mixing of manure with soil during trampling by the livestock (Mugwira 1985).

One way to improve manure quality is to supplement livestock with nutrient rich concentrates and fodder. Many trees and shrubs used in agroforestry systems provide fodder that can improve the quality of manure produced. Jama et al. (1997) showed that high P-content manure (0.49% P) can be obtained if the grass fed to zero-grazed improved breed dairy cows is supplemented with the fresh leaves of *Calliandra calothyrsus*. The effect of the resultant high quality manure increased crop yield both during the season of application as well as during the subsequent season due to residual effects.

The problem of low manure availability in smallholder farms is also addressed through increasing its use efficiency. One such strategy is placement of the manure in the planting hole instead of broadcasting, a common practice among farmers in the region. Spot application also reduces leaching and volatilization effects and maximizes yield. Spot placement or dribbling of manure into the planting furrow each year, rather than broadcast application at high rates every few years, are promising ways of increasing the recurrent crop yields benefits from cattle manure (Munguri et al. 1995). Spot placement however requires farmer knowledge, skills, labor inputs as well as good manure preparation (Ransom et al. 1995). Although data on losses of nutrients during manure management in smallholder farming is generally lacking some recent estimates, suggest

that up to 60% N and 10% of P can be lost through poor manure management. Since 40 to 60% of the N excreted by livestock (ruminants) is in the form of urine, the potential for nutrient loss can be greater under stall-feeding than range grazing systems where only excreta is captured and applied to crop fields (Powell and Williams, 1995).

To increase manure use however, some myths surrounding the use of manure should be addressed. For example, application of raw manure in the planting holes leads to crop 'burning' as often reported by farmers, calling for extension and farmer education. Empowering farmers through greater understanding and application of principles is paramount (Murwira 2003). Murwira et al. (2004) and Bwalya (2005) also highlight the need to consider short-term and long-term effects, economic and environmental factors, farmer perceptions and other limiting nutrients to make manure recommendations. Socio-economic factors of importance are labour availability, cash income, livestock ownership and farmers indicators of manure quality, transport of manure, competitive use such as fuelwood and family headship. Simple indicators of manure quality used by farmers have been used to develop a decision guide, and present a valuable tool for farmer training (Murwira et al. 2004).

Grain legumes

Legumes play a central role in maintaining soil productivity in smallholder agriculture in southern Africa. Mixed intercropping of cereals with grain legumes such as groundnuts (*Arachis hypogaea*) soybeans (*Glycine max* [L] Merr) and *Phaseolus* beans or tree legumes such as pigeonpeas (*Cajanus cajan*) has been advocated (MacColl 1989). Grain legumes are also used as sole crops in rotation with cereals, are intercropped and occasionally used as green manures. Self-nodulating promiscuous types of soyabean, pigeonpea, groundnut, bambara nut and cowpea are the most promising legumes in Malawi, Zambia and Zimbabwe. Perennial legumes are sometimes retained in farmer's fields and are being incorporated in agroforestry interventions as improved fallows and fodder banks. Late

maturing pigeonpea is especially promising as an intercrop with maize in densely populated areas where land is scarce and animals are few such as southern Malawi.

Biological nitrogen fixation (BNF) makes a significant contribution to N supply (Table 3) and for many poor farmers, BNF is an essential, cost effective alternative or complementary solution to industrially manufactured N fertilizers particularly for staple crops. Tropical grain legumes can certainly fix substantial amounts of N given favourable conditions, but the majority of this N is often harvested in the grain. Legumes such as soybean that have been subject to intense breeding efforts are very efficient at translocating their N into the grain, and even when the residues are returned to the soil there is generally a net removal of N from the field (Giller et al. 1994). Some promiscuous soybean varieties that are leafier, have a greater potential to add N to the soil, and are potentially more appropriate for cultivation by smallholder farmers than the recommended varieties grown on commercial farms in southern Africa (Mpepereki et al. 1996). Soybean residues at harvest are lignified (10% lignin) with C/N ratios around 45:1 and these tend to immobilize N when they are added to the soil (Toomsan et al. 1995). By contrast, groundnut (*Arachis hypogaea* L.) residues can contain >160 kg N ha⁻¹, are less lignified (5% lignin), and are rich in N, as the crop is harvested while still green.

Table 3 N fixed on smallholder farms in southern Africa by various legumes

Legume	N ₂ fixed kg ha ⁻¹	Source
Bambara nut	52	Rowe and Giller (2003)
Cowpea	47	Rowe and Giller (2003)
Groundnut	33	Rowe and Giller (2003)
Pigeonpea	39	Rowe and Giller (2003)
Pigeonpea	3–82	Mapfumo et al (2000)
Pigeonpea	97	Chikowo et al. (2004)
Cowpea	28	Chikowo et al. (2004)
<i>Acacia angustissima</i>	122	Chikowo et al. (2004)
<i>Sesbania sesban</i>	84	Chikowo et al. (2004)
<i>Gliricidia sepium</i>	212	Mafongoya PL
<i>Acacia angustissima</i>	210	Mafongoya PL
<i>Leucaena collinsii</i>	300	Mafongoya PL
<i>Tephrosia candida</i>	280	Mafongoya PL
<i>Tephrosia vogelii</i>	157	Mafongoya PL

For many years rotation of maize with groundnut has been the most common crop sequence on smallholder farms in sub-humid parts of Zimbabwe (Shumba 1983; Metelerkamp 1987). Under favourable management and when groundnut residues are incorporated on sandy soils, groundnut in rotation with maize can double the yield of the following maize, particularly when the maize is grown with little or no N fertilizer (Mukurumbira 1985). Another success is the use of a sole pigeon pea crop that can drop up to 40 kg N ha⁻¹ in fallen leaves during its growth (Kumar-Rao et al. 1983) and its small N harvest index means that a relatively large proportion of the fixed N remains in the field and can be of substantial benefit to subsequent crops as observed in Malawi (Kumwenda, 1996). In addition, the rooting habit of pigeon pea has an added advantage of mining nutrients from deeper soil horizons thereby enriching the upper surface of the soil through leaf fall and litter decomposition (Van Noordwijk 1989; Mekonnen et al. 1997).

Intercropping of grain legumes generally results in the legume deriving a greater proportion of its N from N₂ fixation than when grown alone, but legume dry-matter production and N accumulation are usually reduced because of competition from the companion crop (Table 4) so that the overall amount of N₂ fixed is less than that of sole crop of a legume. Cowpea intercropping was advantageous with maize or millet in seasons with adequate rainfall, but the cowpea competed strongly with the cereal crop for soil water when

Table 4 Maize grain yields in intercropping systems with *Tephrosia candida* and *Cajanus cajan* in Chipata, Zambia

Treatment	Grain yield t ha ⁻¹		
	Year 1	Year 2	Total
Fertilized maize	2.3	0.7	3.0
Unfertilized maize	0.6	0.7	1.3
<i>Tephrosia candida</i> (provenance 02970 + Maize)	0.9	0.8	1.7
<i>Tephrosia candida</i> (provenance 02971 + Maize)	0.8	1.0	1.8
<i>Tephrosia candida</i> (provenances 02972 + Maize)	1.0	1.1	2.1
<i>Tephrosia candida</i> + Maize	1.3	1.0	2.3
<i>Cajanus cajan</i> + Maize	0.8	0.8	1.6

rainfall was limiting (Shumba et al. 1990). One notable exception again is traditional pigeonpea, which has a phenology complementary to that of most cereal crops. Its initial aboveground growth and development is very slow, hence there is little direct competition between the two crops (Natarajan and Mafongoya 1992). The long duration growth habit and its ability to root deeply allow the pigeonpea to grow on after the companion cereal crop has been harvested, utilizing residual moisture in the soil (Table 4). However, although sole pigeonpea produced clear residual effects in the growth of subsequent maize, the residual effects of maize and pigeonpea intercrops were not substantial, presumably because of reduced inputs of N. Benefits are more likely to accrue to subsequent crops as the main transfer pathway is due to root and nodule senescence and fallen leaves (Ledgard and Giller 1995).

But virtually all the information that is available on legume N contributions is from research conducted on experimental stations where the crops have been adequately fertilized with P and other nutrients, and sometimes irrigated. As biomass and yields of sole-cropped grain legumes under smallholder conditions in Africa are often small (<500 kg ha⁻¹ of grain), the amounts of N₂ fixed are also little. For example, in the Usambara Mountains in northern Tanzania, where bean (*Phaseolus vulgaris* L.) is the staple grain legume, most farmers' crops lacked nodules because of severe P deficiency, and amounts of N₂ fixed were estimated to be 2–8 kg N ha⁻¹ (Amijee and Giller 1998).

Much of the work on legume based technologies has been done on research stations with little attention to tailor these technologies to smallholder conditions where labor is a problem. The fertilizer which is needed to jump start the system may be too costly or not available and some legume seeds are often difficult to obtain. It may also be difficult to release land from staple food crop production to produce legumes that are efficient in N₂ fixation but have a low food value. The legume market is also not very well developed and farmers will not give up cereal production for legumes. Other issues that need to be addressed are early planting of legumes which is necessary although it brings competition for labour at the onset of rains; time of legume

biomass incorporation is also important to avoid being eaten by animals but incorporating immediately after harvest may also interfere with marketing; legume pests and diseases which present a bottleneck to produce sufficient legume biomass (Kabambe 1996).

Agroforestry options

Planted tree fallows with leguminous trees or shrubs that accumulate N in the biomass through biological nitrogen fixation (BNF) (Table 5) and capture of subsoil N (otherwise unutilized by crops) have been found to be an excellent option to replace natural fallows and increase maize yields on N deficient sites (Ajayi et al. 2004; Kwesiga et al. 1999; Kwesiga and Coe 1994). Two-year tree fallows of *Sesbania* (*Sesbania sesban* [L] Merr.) or *Tephrosia* (*Tephrosia vogelii* Hook. F.) are able to replenish soil N to levels sufficient to grow three subsequent high-yielding maize crops in N-depleted but P-sufficient soils in southern Africa (Kwesiga and Coe 1994; Kwesiga et al. 1998). In general, woody fallows accumulate larger N stocks than herbaceous ones because of their larger and continuing biomass accumulation. The residual effects of tree fallows are therefore longer than herbaceous fallows and grain legume crops. Large-scale adoption of fertilizer trees by farmers is now taking place across southern Africa.

Using non-coppicing species

Since the work of Kwesiga and Coe (1994) on *Sesbania* fallows, much has been learned about the performance of improved non-coppicing fallows such as *Sesbania sesban*, *Tephrosia vogelii*, *Tephrosia candida*, *Cajanus cajan*, and *Crotalaria* spp. The performance of *Sesbania* and *Tephrosia* under a wide range of biophysical conditions for example is shown in Table 6. These improved fallows of 2 year duration significantly increased maize yields well above those of unfertilized maize, the most common farmer practice in the region. The problem demonstrated in these trials was that the residual effects of these improved fallows on maize yield declined after the second year of cropping (Table 5). In the third year of

cropping, maize yields following fallow were similar to those of unfertilized maize. The marked decline of maize yields two or three seasons after a non-coppicing fallow is probably related to depletion of soil nutrients and/or to deterioration in soil chemical and physical properties. In Zambia, *Sesbania sesban* was found to perform poorly in areas where soils were poor and rainfall was low but fairly well in better soils (Goma, 2003).

Using coppicing species

Unlike non-coppicing species, coppicing species such as *Gliricidia sepium*, *Leucaena leucocephala*, *Calliandra calothyrsus*, *Senna siamea* and *Flemingia macrophylla* show increases in residual soil fertility beyond 2–3 years because of the additional organic inputs that are derived each year from coppice regrowth that is cut and applied to the soil. An experiment was established in the early 1990s at Msekera Research Station to examine these relationships. These plots were cropped for 10 years during which both maize yields and coppice growth were monitored (Fig. 1). The species showed significant differences in their coppicing ability and biomass production, with *Leucaena*, *Gliricidia* and *Senna siamea* having the greatest coppicing ability and biomass production, while *Calliandra* and *Flemingia* performed poorly over all 10 years. There were no significant differences in maize grain yield between *Gliricidia* and *Leucaena* fallows over the seasons. In experiments conducted in other different sites in Malawi, however, *Gliricidia* seemed to be the most effective species in increasing maize yield but its use was constrained by seed availability and its growth was limited to some parts of the country only (Phombeya et al. 1996). In Zambia, the growth of

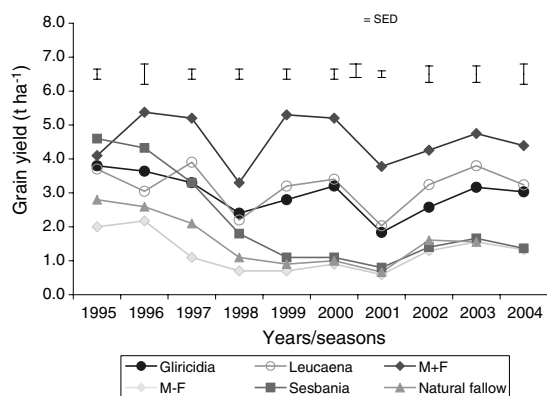

Fig. 1 Grain yield (t ha^{-1}) obtained from various fallow species for ten seasons at Msekera Research Station, Zambia

both *Gliricidia* and *Leucaena* was improved by liming and P application (Goma, 2003).

Species such as *Leucaena* and *Gliricidia* which have good coppicing ability produce large amounts of high-quality biomass, with high nitrogen content and low contents of lignin and polyphenols thereby contributing to higher maize yields (Mafongoya and Nair 1997; Mafongoya et al. 1998). While *Sesbania* produces high quality biomass, its lack of coppice regrowth means that it cannot supply nutrients for an extended period of cropping. Species such as *Flemingia*, *Calliandra* and *Senna siamea*, on the other hand, produce low-quality biomass, high in lignin and polyphenols and low in nitrogen. Their use as fallow species leads to N immobilization and reduced maize yields.

Biomass transfer using fertilizer-tree biomass

Biomass transfer using fertilizer-tree species is shown as a sustainable means for maintaining

Table 5 Maize yields for two season following soyabean in a sandy loam soil in a smallholder farm Hurungwe Zimbabwe (1998/99)

Source: Adapted from Mpepereki and Pompi (2002)

Soyabean variety	N fixed (kg ha^{-1})	Soyabean biomass incorporated (t ha^{-1})	Maize yield (t ha^{-1})	
			97/98	98/99
Magoye (promiscuous)	90	5.4	2.3	1.2
Local (promiscuous)	90	4.9	2.1	1.4
Roan (Specific)	88	3.2	1.8	0.9
Nyala (Specific)	82	2.8	1.4	0.8
Maize control	Nil	Nil	0.2	0.2

Table 6 Maize grain yield after *Sesbania sesban* and *Tephrosia vogelii* fallows on farmers' fields in eastern Zambia during 1998–2000

Fallow species	Maize grain yield t ha ⁻¹			
	Land use system (LUS)	Year 1	Year 2	Year 3
Farmers testing <i>Sesbania sesban</i> fallows	Sesbania fallow	3.6	2.0	1.6
	Fertilized maize	4.0	4.0	2.2
	Unfertilized maize	0.8	1.2	0.4
	LSD (0.05)	0.7	0.6	1.1
	Number of farmers	8	6	4
Farmers testing <i>Tephrosia vogelii</i> fallows	Tephrosia fallow	3.1	2.4	1.3
	Fertilized maize	4.2	3.0	2.8
	Unfertilized maize	0.8	0.1	0.5
	LSD (0.05)	0.5	0.6	0.9
	Number of farmers	17	9	5

nutrient balances in maize and vegetable-based production systems, as the tree leafy materials are able to supply N to the soil (Kuntashula et al. 2004). The transfer involves producing high-quality biomass through the establishment of on-farm 'biomass banks' from which the biomass is cut and transferred to crop fields in different parts of the farm. Synchrony between nutrient release from tree litter and crop uptake can be achieved with well-timed biomass transfer. The management factors that can be manipulated to achieve this are litter quality, rate of litter application, method and time of litter application (Mafongoya et al. 1998).

Biomass transfer technologies require a lot of labor for managing and incorporating the leafy biomass. If used for the production of low-value crops like maize, the higher maize yield from biomass-transfer technologies may not be enough to compensate for the higher labor cost. Most economic analyses have concluded that it is unprofitable to invest in biomass transfer when labor is scarce and its cost is thus high. However, when prunings are applied to high-value crops like vegetables, the technology becomes profitable (ICRAF 1997). For instance, farmer participatory experiments conducted in 2000–2004 by Kuntashula et al. (2004) have shown that biomass transfer using *Leuceana leucocephala* and *Gliricidia sepium* is tenable for sustaining vegetable production in seasonal wetlands (dambos). In addition to increasing yields of vegetables such as cabbage, rape, onion and tomato and maize grown after vegetable harvests, biomass transfer has shown

potential to increase yields of other high-value crops such as garlic (Table 7). At Bunda college in Malawi, it was found that 10 t ha⁻¹ of *Leucaena* leaf biomass is just as effective as 100 kg ha⁻¹ of inorganic fertilizer N (Kazombo-Phiri 2005).

Whether coppicing or non-coppicing fallows or biomass transfer systems, work done for many years has shown how organic matter decomposition and nutrient release are affected by the levels of polyphenol (P), lignin (L) and nitrogen (N) content of the organic inputs (Mafongoya et al. 1998). Recently studies have also shown that maize yields after fallows with various tree legumes were negatively correlated with the (L + P): N ratio and positively correlated with recycled biomass. Fallow species with high N, low lignin and low polyphenols such as *Gliricidia* and *Sesbania* gave higher maize yields compared to species such as *Flemingia*, *Calliandra* and *Senna*. Mafongoya et al. (2000) has shown that it is not the quantity of polyphenols that is critically important, but rather their quality as measured by their protein-binding capacity.

Where land is limiting, the feasibility of fallow systems is yet to be proved. In such situations trees are grown simultaneously with crops (Kazombo-Phiri 2005). This mixed system is being adopted by farmers in southern Malawi using *Gliricidia sepium*. When trees are associated with crops they can compete for moisture, nutrients and light. But *Faidherbia albida*, usually intercropped with crops increases yields of cereal by 50–250% and is perhaps the most important agroforestry species in Malawi (Kazombo-Phiri 2005).

Table 7 Selected vegetable yields (t ha^{-1}) in dambos using inorganic fertilizers or organic inputs from manure, tree leaf biomass in Chipata district, Zambia

Treatments	Cabbage yield ($n = 31$); (2000)	Green maize cob yield after onion (t ha^{-1})	Onion yield ($n = 12$) (2001)	Green maize cob yield after cabbage (t ha^{-1})	Garlic yield ($n = 6$); (2004)
Manure 10 t +1/2rec. fertilizer	66.8	11.6	96.0	11.7	9.1
Recommended fertilizer	57.6	8.4	57.1	10.4	7.2
12 t <i>Gliricidia sepium</i>	53.6	12.4	79.8	17.3	–
8 t <i>Gliricidia sepium</i>	43.1	10.9	68.3	14.9	10.3
12 t <i>Leucaena leucocephala</i>	32.6	–	–	13.0	–
Non-fertilized	17.0	6.4	28.1	7.8	4.2
SED	5.3***	2.06***	11.2*	3.04*	1.2***

– treatment not evaluated, *significant at $P < 0.05$; **significant at $P < 0.01$; ***significant $P < 0.001$

The adoption of agroforestry options is quite low compared to grain legumes. Factors which affect adoption include, land tenure, labor shortage availability of seed and waiting for 2–3 years without benefits. However, current work of ICRAF and non-governmental organizations (NGOs) in southern Africa is showing encouraging results in adoption of various agroforestry options. Case studies on scaling up agroforestry options have been summarized by (Franzel et al. 2004).

Combined inorganic and organic inputs

Many reports in the literature have showed that continuous use of sole fertilizers may lead to shortage of nutrients not supplied by the chemical fertilizers and may also lead to chemical soil degradation. Chemical fertilizers are also too costly for farmers to apply the recommended rates. On the other hand, sole application of organic matter is constrained by low availability of N to the current crop (Hagggar et al. 1993) low or imbalanced nutrient content, unfavorable quality and high labour demands for transporting bulky materials (Palm et al. 1997). The low P content of most organic materials indicates that in the long term addition of external sources of P will be needed to sustain crop productivity. The alternative is to combine application of organic matter and fertilizer so that improved crop yields are maintained without degrading soil fertility status (Swift et al. 1994).

There is substantial evidence demonstrating gains in crop productivity from nutrient additions

through mixtures of organic and inorganic sources of nutrients compared with inputs alone (Swift et al. 1994). Combination of animal manure with inorganic fertilizers for instance is a common practice among smallholder farmers in Zimbabwe. Supplementation of 5 t ha^{-1} with 40 kg N ha^{-1} (inorganic fertilizer) in Zimbabwe resulted in a statistically higher yield than sole manure treatment (Murwira et al. 2002). Studies by (Murwira and Kirchmann 1993) showed that synchrony between N release and crop uptake was best achieved by applying combinations of manure and mineral N and having it in such a way that the N is applied a little later. Late application of mineral N reduced the amount N lost through leaching. Similar results were also reported in biomass transfer systems using manure and fertilizer on vegetables (Table 7, Kuntashula et al. 2004) and improved fallows when combined with small amounts of inorganic fertilizers (Fig. 2). This could be attributed to P addition from inorganic fertilizers or K or N which may not be supplied in sufficient amounts by organic inputs alone leading to better synchrony of nutrient release and uptake.

There are lots of technologies available to manage soil fertility in southern Africa and the range available to farmers is summarized in Table 8. The current challenge is how to increase small-holder farmer adoption of these soil fertility replenishing options. The paradox between profitability and contribution of agricultural technologies to soil fertility should be unraveled through appropriate integrative and more participatory research.

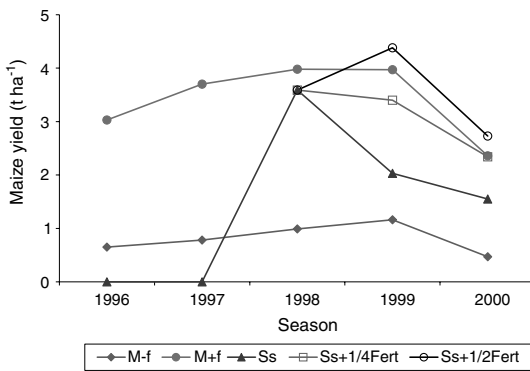

Fig. 2 Interaction of inorganic fertilizer and sesbania fallows on maize grain yield

Conclusions

Smallholder farmers in southern Africa have adopted high yielding maize varieties and other crops such as cotton, sunflower and grain legumes with some success. However, increases in crop yields have been disappointing. This is largely as

result of declining soil fertility among many other factors. This problem is widespread and is becoming worse with market liberalization in southern Africa. Most nutrient budgets show a negative balance due to soil mining and little use of inorganic fertilizer and organic inputs.

The question to be posed is how to build up and maintain soil fertility under the poverty faced by many farmers. The need for added external nutrients is imperative. However, inorganic fertilizers are expensive, their use is sometimes unprofitable especially because of blanket recommendations. The solution to soil fertility problems will not depend on use of inorganic fertilizers alone. More attention should be directed to the use of organic inputs especially better integration of legume crop into cropping systems through legume rotation and intercropping, use of improved fallows in agroforestry as well as animal manures.

The paradigm of research and development on soil fertility options must change. The approaches

Table 8 Soil fertility options available and appropriate to farmers in southern Africa

Contribution to soil fertility	Soil fertility option	Rank	Remarks/Constraints	Ease of adoption by farmers
<div style="display: flex; align-items: center;"> <div style="writing-mode: vertical-rl; transform: rotate(180deg); margin-right: 5px;">High</div> <div style="flex-grow: 1; border-left: 1px solid black; border-right: 1px solid black; position: relative;"> <div style="position: absolute; top: -15px; left: 50%; transform: translate(-50%, -50%);">Low</div> <div style="position: absolute; bottom: -15px; left: 50%; transform: translate(-50%, 50%);">High</div> </div> </div>	<ul style="list-style-type: none"> Crop rotation with legumes Intercrop with legumes 	1	<ul style="list-style-type: none"> - Food security concerns - Limited land 	High
	Inorganic fertilizer	2	<ul style="list-style-type: none"> - Little N contribution to subsequence crop - Poor legume growth - Insufficient cash to buy - Untimely distribution - Scarcity of input markets in rural areas 	
	Use of livestock manure	3	<ul style="list-style-type: none"> - Risk environment and profitability issues - Unavailability, farmers some do not have livestock, problems of weed - Poor quantities of manure 	
	Agroforestry technologies	4	<ul style="list-style-type: none"> - Higher labour requirements - Opportunity cost of leaving land fallow for 2 years is too higher - Immediate food concern - Variable performance agroforestry of options is highly degraded soils 	

Source: Various surveys conducted by Soil Fertility Network Scientists in Malawi, Zambia and Zimbabwe. Ranking was done by farmers.

need to move from rigid and prescriptive approach to flexible, problem solving format with a lot of farmer participation. There is need for social science research to deal with issues of adoption and scaling up of the available options. Potential synergies to address soil fertility problems can be gained by combining technical options with farmer's knowledge as well as new approaches to farmer training and policy dialogue. Policy issues touching on the soil resource base, as well as product markets need to be addressed to ensure use of agricultural technological innovations.

References

- Ajayi OC, Place F, Kwesiga F, Mafongoya PL (2004) Impacts of Natural Resource Management Technologies on Small-scale Farmers: Case of Fertilizer Tree fallows in Zambia (Book chapter in a book compendium of case studies of the impacts of natural resource management research to be published by the Standing Panel on Impact Assessment (SPIA) of the CGIAR Science Council)
- Ahmed MM, Rohrbach DD, Gono LT, Mazhangara EP, Mugwira L, Masendeke DD, Alibaba S (1997) Soil fertility management in communal areas of Zimbabwe: current practices, constraints and opportunities for change. ICRISAT Southern and Eastern Africa regional working paper 6, Bulawayo, Zimbabwe: International Crops Research Institute for the Semi-Arid Tropics (ICRISAT)
- Amijee F, Giller KE (1998) Environmental constraints to nodulation and nitrogen fixation of *Phaseolus vulgaris* L. in Tanzania: a survey of soil fertility and root nodulation. *Afr J Crop Sci* (in press)
- Blackie MJ, Jones RB (1993) Agronomy and increased maize productivity in southern Africa. *Biol Agricul Horticult* 9:147–160
- Bwalya M (2005) Farmer innovations in mitigating water and nutrient deficiencies in rain fed agriculture: lessons from African Conservation Tillage joint pilot activities in Zimbabwe, Zambia and South Africa. 67–81. In Omany GO and Pasternak D (eds) 2005. Sustainable Agriculture Systems for the Drylands. Proceedings of the International Symposium for Sustainable Dryland Agriculture Systems, 2–5 December 2003, Niamey, Niger, 336pp
- Carter SE, Murwira HK (1995) Spatial variability in soil fertility management and crop response in Mutoko communal area, Zimbabwe. *AMBIO* 24:77–84
- Chikowo R, Mapfumo P, Nyamugafata P, Giller KE (2004) Woody legume fallow productivity, biological N₂-fixation and residual benefits to two successive maize crops in Zimbabwe. *Plant Soil* 262:303–315
- Conroy AC, Kumwenda JDT (1995) Risks associated with the adoption of hybrid seed and fertilizer by small-holder farmers in Malawi. In: Jewell DC, Waddington SR, Ransom JK, Pixley KV (eds) Maize research for stress environments: Proceedings of the 4th eastern and southern Africa regional maize conference, Harare, Zimbabwe, 28 March–1 April 1994. International Maize and Wheat Improvement Center (CIMMYT), Harare
- FAO (2003) Arable and permanent cropland, tractor usage, irrigated land, fertilizer use and pesticide use, FAO: Food and Agriculture Organization of the United Nations (FAO), FAOSTAT on-line statistical service
- Franzel S, Denning GL, Lilleso JPB, Mercado Jr AR (2004) Scaling up the impact of agroforestry: lessons from three sites in Africa and Asia. *Agroforestry Syst* 61:329–344
- Giller KE, McDonagh JF, Cadisch G (1994) Can biological nitrogen fixation sustain agriculture in the tropics? In: Syers JK, Rimmal DL (eds), Soil science and sustainable land management in the tropics. CAB Int., Wallingford, England, pp 173–191
- Goma HC (2003) Potential for changing traditional soil fertility management systems in the wet miombo woodlands of Zambia: the chitemene and fundikila systems: In: Gichuru MP, Bationo A, Bekunda MA, Goma HC, Mafongoya PL, Mugendi DN, Murwira HK, Nandwa SM, Nyathi P, Swift MJ (eds). 2003. Soil fertility management in Africa: a regional perspective, pp 187–218
- Grant PM (1981) The fertility of sandy soil in peasant agriculture. *Zimbabwe Agricul J* 78:169–175
- Guar AC, Neelakanan S, Dargan KS (1984) Organic manure. Indian Council of Agriculture Research, New Delhi, India
- Haggard JP, Tanner EU, Beer JW, Kass DCL (1993) Nitrogen dynamics of tropical agroforestry and annual cropping systems. *Soil Biol Biochem* 25:1363–1378
- Haque I (1993) Nutrient management and feed improvement in crop livestock systems of Saharan Africa: present status and future outlook. ILCA Environmental Sciences Division Working Document No. 28. ILCA (International Livestock Centre for Africa), Addis Ababa, Ethiopia
- Heisey PW, Mwangi W (1996) Fertilizer use and maize production in sub-Saharan Africa. Economics Working Paper 96–01. pp 34. Mexico, D.F.: CIMMYT
- Henao J, Baanante CA (1999) Estimating rates of nutrient depletion in soils of agricultural lands of Africa. Int Fertilizer Developing Centre, Muscle Shoals, AL
- Hikwa D, Mukurumbira L (1995) Highlights of previous, current, and proposed soil fertility research by the Department of Research and Specialist Services (DRSS) In Zimbabwe. In: Waddington SR (eds) Report on the First Meeting of the Network Workings Group. Soil Fertility Research Network for Maize-Based Farming Systems in Selected Countries of Southern Africa. Rockefeller Foundation Southern Africa Agricultural Sciences Program and the Inter-

- national Maize and Wheat Improvement Centre Maize Program, Lilongwe and Harare, pp 1–2
- ICRAF (1997) Annual Report 1996. International Centre for Research in Agroforestry, Nairobi, Kenya
- ICRISAT (2006) Spreading the Word on Fertilizer in Zimbabwe. Global Theme on Agroecosystems. Report No.24
- Jama BA, Swinkels RA, Buresh RJ (1997) Agronomic and economic evaluation of organic and inorganic sources of phosphorus in western Kenya. *Agronomy J* 89: 597–604
- Jones RB, Wendt JW (1995) Contribution of soil fertility research to improved maize production by smallholders in eastern and southern Africa. In Jewell DC, Waddington SR, Ransom JK, Pixley KV (eds), *Maize Research for Stress Environments. Proceedings of the Fourth Eastern and Southern Africa Regional Maize Conference*. CIMMYT, Mexico D.F., pp 2–14
- Kabambe VH (1996) Crop Competition, Suppression of *Striga asiatica* (L.) Kunze infestation at different nitrogen levels: preliminary results. In Waddington SR (eds) *Soil fertility network for Maize-based farming systems in selected countries in southern Africa: Research results and network outputs in 1994 and 1995*. CIMMYT, Mexico D.F., pp 100–107
- Kazombo-Phiri SFM (2005) Main causes of declining soil productivity in Malawi: Effects on agriculture and management technologies employed to alleviate the problems.59–66: In: Omanyua GO and Pasternak D (eds) 2005. *Sustainable Agriculture Systems for the Drylands. Proceedings of the International Symposium for Sustainable Dryland Agriculture Systems, 2–5 December 2003, Niamey, Niger* 336 pp
- Kumar-Rao JVDK, Dart PJ, Sastry PVSS (1983) Residual effect of pigeonpea (*Cajanus cajan*) on yield and nitrogen response of maize. *Exp Agric* 19:131–141
- Kumwenda JDT, Waddington S, Snapp SS, Jones JB, Blackie MJ (1997) Soil fertility management in the smallholder maize based cropping systems of eastern and southern Africa. In Eisher C (eds) *The Emerging Maize Revolution*. Michigan State University E. Lansing, MI, USA, pp 153–172
- Kumwenda JDT, Waddington SR, Snapp SS, Jones RB, Blackie MJ (1995) Soil fertility management research for the smallholder maize-based cropping systems of southern Africa: A review. *Soil Fertility Network for Maize-Based Cropping Systems in Countries of Southern Africa, Network Research Working Paper Number 1*, pp 34. Harare, Zimbabwe: CIMMYT
- Kumwenda JDT (1996) Interplanting Legume Manure Crops in Maize in Malawi: Preliminary Results. In Waddington SR (ed). *Soil fertility network for Maize-based farming systems in selected countries in southern Africa: Research results and network outputs in 1994 and 1995*. CIMMYT, Mexico D.F., pp 35–40
- Kuntashula E, Mafongoya PL, Sileshi G, Lungu S (2004) Potential of biomass transfer technologies in sustaining vegetable production in the wetlands (dambos) of eastern Zambia. *Exp Agric* 40:37–51
- Kwesiga F, Coe R (1994) The effect of short rotation *Sesbania sesban* planted fallows on maize yield. *For Ecol Manage* 64:199–208
- Kwesiga F, Franzel S, Place F, Phiri D, Simwanza CP (1998) *Sesbania sesban* improved fallows in eastern Zambia: the inception, development and farmer enthusiasm. In Buresh RJ, Cooper PJ (eds) *The science and practice of short-term improved fallows*. Kluwer Academic Publication, Dordrecht, the Netherlands
- Kwesiga FR, Franzel S, Place F, Phiri D, Simwanza CP (1999) *Sesbania sesban* improved fallows in eastern Zambia: their inception, development and farmer enthusiasm. *Agroforestry Syst* 47:49–66
- Ledgard SJ, Giller KE (1995) Atmospheric N₂ fixation as an alternative nitrogen source. In Bacon P (eds) *Nitrogen fertilization and the environment*. Merceel Dekker, New York, pp 443–486
- MacColl D (1989) Studies on maize (*Zea mays* L.) at Bunda, Malawi. II. Yield in short rotation with legumes. *Experimental Agriculture* 25: 367–374
- Mafongoya PL, Nair PKR (1997) Multipurpose tree prunings as a source of nitrogen to maize under semiarid conditions in Zimbabwe. Nitrogen recovery rates in relation to pruning quality and method of application. *Agroforestry Syst* 35:47
- Mafongoya PL, Barak P, Reed JD (2000) Carbon, nitrogen and phosphorus mineralization from multipurpose tree leaves and manure from goats fed these leaves. *Biol Fertility Soils* 30:298–305
- Mafongoya PL, Giller KE, Palm CA (1998) Decomposition and nitrogen release patterns of tree prunings and litter. *Agroforestry Syst* 38:77–97
- Mapfumo P, Campbell BM, Mpeperekwi S, Mafongoya PL (2000) Legumes in soil fertility management. Opportunities for pigeonpea in smallholder farming systems of Zimbabwe. *African Crop Science Journal* 36:423–424
- Mekonnen K, Buresh RJ, Jama B (1997) Root and inorganic distribution of *Sesbania fallows*, natural fallow and maize. *Plant Soil* 188:319–327
- Metelerkamp HRR (1987) Review of crop research relevant to the semiarid areas of Zimbabwe. In *Cropping in the semiarid areas of Zimbabwe. Proceedings of a workshop held in Harare, 24–28 August 1987*, pp 190–315
- Mpeperekwi S, Pompei I (2002) Promoting new BNF technologies among smallholder farmers: a success story from Zimbabwe. In: Waddington SR (ed) 2003. *Grain legume and green manures for soil fertility in Southern Africa: taking stock of progress. Proceedings of a conference held 8–11 October 2002 at the Leopard Rock Hotel, Vumba, Zimbabwe*. Soil Fert Net and CIMMYT-Zimbabwe, Harare, Zimbabwe, 246pp
- Mpeperekwi SF, Makonese F, Giller KE (1996) Soybeans in smallholder farming systems in Zimbabwe. CIMMYT, Harare, Zimbabwe
- Mugwira L, Mukurumbira L (1985) Nutrient supplying power of different groups of manure from communal

- areas and their effect on plant growth and maize grain yields. *Zimbabwe Agricultural J* 83:25–2
- Mugwira LM (1985) Effects of supplementing communal area manure with lime and fertilizer on plant growth and nutrient uptake. *Zimbabwe Agricultural J* 82:153–159
- Mukurumbira LM (1985) Effects of rate of fertilizer nitrogen and previous grain legume crop on maize yields. *Zimbabwe Agric J* 82:177–179
- Munguri MW, Mariga IK, Chivinge OA (1995) The potential of optimizing cattle manure use with maize in Chinjika Resettlement Area, Zimbabwe. In Waddington SR (eds) *Soil Fertility Network for Maize-based Farming Systems in Selected Countries of Southern Africa Research Results and Network Outputs in 1994 and 1995*. CIMMYT, Harare, Zimbabwe, pp 46–51
- Mureithi JG, Taylor RS, Thorpe W (1994) The effects of alley cropping with *Leucaena leucocephala* and of different management practices on the productivity of maize and soil chemical properties in lowland coastal Kenya. *Agroforestry Systems* 27:31–51
- Murwira HK (2003) Managing Africa's Soils: Approaches and Challenges. In: Gichuru MP, Bationo A, Bekunda MA, Goma HC, Mafongoya PL, Mugendi DN, Murwira HK, Nandwa SM, Nyathi P, Swift MJ (eds) *Soil fertility management in Africa: A regional perspective*, pp 293–306
- Murwira HK, Kirchmann H (1993) Nitrogen dynamics and maize growth in a Zimbabwean sandy soil under manure fertilization. *Communications Soil Sci Plant Ana* 24:2343–2359
- Murwira HK, Mutiro K, Chivenge PP (2004) Decision guides on manure use: a communication strategy. In: Williams TO, Tarawali SA, Hiernaux P, Fernandez-Rivera S (eds) *Sustainable crop-livestock production for improved livelihoods and natural resource management in West Africa*. Proceeding of an International Conference held at the International Institute of Tropical Agriculture (IITA), Ibadan, Nigeria, 19–22 November 2001. ILRI (International Livestock Research Institute), Nairobi, Kenya and CTA, Wageningen, The Netherlands. 528+12pp
- Murwira HK, Mutuo P, Nhamo N, Marandu EA, Rabeson R, Mwale M, Palm CA (2002) Fertilizer equivalency values of organic materials of differing quality. In: Vanlauwe B, Diels J, Sanginga N, Merckx R (eds). *Integrated plant nutrient management in sub-Saharan Africa: from concept to practice*. CAB International, Wallingford, UK, pp 352
- Murwira HK, Swift MJ, Frost PGH (1995) Manure as a key resource in sustainable agriculture. In: Powell LM, Fernandez-Rivera S, Williams OT, Renard C (eds) *Livestock and sustainable nutrient cycling in mixed farming systems of sub-Saharan Africa*. Volume II. Technical papers. Proceeding of an International Conference held in Addis Ababa, Ethiopia, 22–26 Nov. 1993. International Livestock Centre for Africa, Addis Ababa, Ethiopia, pp 131–148
- Nandwa SM (2003) Perspectives on soil fertility in Africa. In: Gicheru MP, Bationo A, Bekunda MA, Goma HC, Mafongoya PL, Mugendi DN, Murwira HM, Nandwa SM, Nyathi P, Swift MJ (eds) *Soil fertility management in Africa: a regional perspective*. Academic Science Publishers (ASP) and Tropical Soil Biology and Fertility of CIAT, Nairobi
- Natarajan M, Mafongoya PL (1992) A study on intercropping of pigeonpea (*Cajanus cajan* L Millsp.) with maize, sunflower and groundnut in Zimbabwe. *Zimbabwe J Agric Res* 30:163–171
- Palm CA, Myers RJK, Nandwa SM (1997) Combined use of inorganic and organic nutrient sources for soil fertility maintenance and replenishment. In: Buresh RJ, Sanchez PA, Calhoun F (eds) *Replenishing soil fertility in Africa*. SSSA Special Publication No. 51. Soil Science Society America, Madison, Wisconsin, USA, pp 193–217
- Piha MI (1993) Optimizing fertilizer use and practical rainfall capture in a semi-arid environment with variable rainfall. *Experimental Agriculture* 29:405–415
- Phombeya HSK, Saka AR, Jones RB (1996) Screening Multi-purpose Tree Species for Hedgerow Intercropping on the Mid-altitude Plateau of Central Malawi. In: Waddington SR (ed) *Soil fertility network for Maize-based farming systems in selected countries in southern Africa: Research results and network outputs in 1994 and 1995*, CIMMYT, pp 41–44
- Powell JM, Williams TO (1995) An overview of mixed farming systems in sub-Saharan Africa. In Powell LM, Fernandez-Rivera S, Williams OT, Renard C (eds) *Livestock and sustainable nutrient cycling in mixed farming systems of sub-Saharan Africa*. Vol 11. Technical papers. Proceeding of an International Conference held in Addis Ababa, Ethiopia, 22–26 Nov. 1993. International Livestock Centre for Africa, Addis Ababa, Ethiopia, pp 21–36
- Probert ME, Okalebo JR, Jones RK (1995) The use of manure on smallholders' farm in semi-arid eastern Kenya. *Experimental Agriculture* 31:371–381
- Ransom JK, Ojiem J, Kanampiu FK (1995) Nutrient flux between maize and livestock in a maize-coffee-livestock system in Central Kenya. In Powell LM, Fernandez-Rivera S, Williams OT, Renard C (eds) *Livestock and sustainable nutrient cycling in mixed farming systems of sub-Saharan Africa*. Volume II. Technical papers. Proceeding of an International Conference held in Addis Ababa, Ethiopia, 22–26 Nov. 1993. International Livestock Centre for Africa, Addis Ababa, Ethiopia, pp 411–419
- Rowe ED, Giller KE (2003) Legumes for soil fertility in southern Africa: Needs, potential and realities. In Waddington SR (eds) 2003. *Grain Legumes and Green Manures for Soil Fertility in the southern Africa: Taking Stock of Progress*. Proceedings of a Conference held 8–11 October 2002 at the Leopard Rock Hotel, Vumba, Zimbabwe. SoilFert Net and CIMMYT-Zimbabwe, Harare, Zimbabwe. 246 pp
- Rusike J, Lo Monaco G, Heinrich GM (2003) Linking technology development and dissemination with market competitiveness: pigeon pea in the semi-arid areas of Malawi and Tanzania. In: Waddington SR (ed)

- Grain legumes and green manures for soil fertility in Southern Africa: taking stock of progress. Harare, CIMMYT, pp 227–235
- Sakala WD (1996) Research-extension linkage through maize fertilizer timing demonstrations in Malawi: In Waddington SR (eds) Soil fertility network for Maize-based farming systems in selected countries in southern Africa: Research results and network outputs in 1994 and 1995. CIMMYT, Mexico D.F., pp 131–134
- Sanchez PA, Shepherd JD, Soule MJ, Place FM, Buresh RJ, Izac AMN, Mokwunye AU, Kwasigwa FR, Ndiritu CG, Woomer PL (1997) Soils fertility replenishment in Africa: An investment in natural resource capital. In Buresh RJ, Sanchez PA, Calhoun F (eds), Replenishing Soil Fertility in Africa, Soil Science Society of America Special Publication 51. SSSA and ASA, Madison, WI, USA, pp 1–46
- Scoones I, Toulmin C (1985) Socio-economic dimensions in nutrient cycling in agropastoral systems in dryland Africa. In Powell JM, Fernandez-Rivera S, Williams TO, Renard C (eds) Livestock and sustainable nutrient cycling in mixed farming systems of sub-Saharan Africa. Vol. 2: technical papers. Proc. of an International Conference held in Addis Ababa, Ethiopia, 22–26 Nov. 1993. ILCA (International Livestock Centre for Africa). Addis Ababa, Ethiopia. 568 pp
- Shumba EM (1983) Factors contributing to a decline in groundnut production in the Mangwende-Murewa District, and the need for a technical research input. *Zimbabwe Agricultural Journal* 80:251–254
- Shumba EM, Dhliwayo HA, Mukoko OZ (1990) The potential of maize-cowpea intercropping in low rainfall areas of Zimbabwe. *Zimbabwe J Agricul Res* 29:81–85
- Stoorvogel JJ, Smaling EMA, Janssen BH (1993) Calculating soil nutrient balances in Africa at different scales. I. supra-national scale. *Fert Res* 35:227–235
- Swift MJ, Seward PD, Frost PGH, Qureshi JN, Muchena FN (1994) Long term experiments in Africa: developing a database for sustainable land use under global change. In Leigh RA, Johnson AE (eds), Long term Experiments in Agricultural and Ecological Sciences, pp 229–251
- Tanner PD, Mugwira L (1984) Effectiveness of communal area manures as sources of nutrients for young maize. *Zimbabwe Agric J* 81:31–35
- Toomsan B, McDonagh JF, Limpinuntana V, Giller KE (1995) Nitrogen fixation by groundnut and soyabean and residual nitrogen benefits to rice in farmers' fields in Northeast Thailand. *Plant Soil* 175:45–56
- Van Noordwijk M (1989) Rooting depth in cropping systems in the humid tropics in relation to nutrient use efficiency. In Van der Heide J (eds), Nutrient Management for Food Crop Production in Tropical Farming Systems. Institute of Soil Fertility, Haren, The Netherlands, pp 129–169
- Waddington SR, Heisey PW (1996) Meeting the nitrogen requirements of maize grown by resource poor farmers in southern Africa by integrating varieties, fertilizer use, crop management and policies. An invited paper presented at the Symposium on Developing Drought- and Low N- Tolerant Maize, CIMMYT, El Batan, Texcoco, Mexico, 24–29 March 1996

Available technologies to replenish soil fertility in East Africa

J. R. Okalebo¹, C. O. Othieno¹, P. L. Woomer², N. K. Karanja³, J. R. M. Semoka⁴, M. A. Bekunda⁵, D. N. Mugendi⁶, R. M. Muasya⁷, A. Bationo⁸ and E. J. Mukhwana²

¹*Department of Soil Science, Moi University, PO Box 1125, Eldoret, Kenya;* ²*SACRED Africa, PO Box 30788, Bungoma, Kenya;* ³*Department of Soil Science, University of Nairobi, PO Box 30197, Nairobi, Kenya;* ⁴*Department of Soil Science, Sokoine University PO Box 3008, Morogoro, Tanzania;* ⁵*Department of Soil Science, Makerere University, PO Box 7062, Kampala, Uganda;* ⁶*Department of Environmental Sciences, Kenyatta University, PO Box 4384, Nairobi, Kenya;* ⁷*Department of Crop Science and Seed Technology, Moi University, PO Box 1125, Eldoret, Kenya;* ⁸*TSBF – CIAT AfNET Co-ordinator, PO Box 30677, Nairobi, Kenya*

Keywords: Affordable, Fertilizers, Infertile soils, Replenishment, Technologies

Abstract

Low inherent soil fertility in the highly weathered and leached soils largely accounts for low and unstained crop yields in most African countries. But in particular, the major nutrients, nitrogen (N) and phosphorus (P), are commonly deficient in these soils. This scenario of nutrient depletion is reflected in food deficits and hence the food aid received continuously, specifically in sub-Saharan Africa. Undoubtedly, substantial efforts have been made in the continent to replenish the fertility of degraded soils in attempts to raise crop yields, towards self-sufficiency and export. Such efforts consist of applications of both organic and inorganic resources to improve the nutrient status of soils and enhanced nutrient uptake by crops, provided that soil moisture is adequate. Overall, positive crop responses to these materials have been obtained. Thus in the East African region, maize (staple) yields have been raised in one growing season from below 0.5 t/ha without nutrient inputs, to 3–5 t/ha from various nutrient amendments at the smallhold farm level. However, in spite of the positive crop responses to nutrient inputs, farmers are generally slow to adopt the soil fertility management technologies. In this paper we review the impact of some technologies, focussing the use of nutrient resources of different characteristics (qualities) in relation to improved crop yields, with an overall goal to enhance technology adoption. Thus, inorganic resources or fertilizers often give immediate crop responses, but their use or adoption is rather restricted to large-scale farmers who can afford to buy these materials. Organic resources, which include crop residues, water hyacinth and agroforestry shrubs and trees, are widely distributed, but they are generally of low quality, reflecting the need to apply large quantities to meet crop nutrient demands. Moreover, most organics will add N mainly to soils. On the other hand, phosphate rocks of varying reactivity are found widely in Africa and are refined elsewhere to supply soluble P sources. The recently developed soil fertility management options in East Africa have targeted the efficient use of N and P by crops and the integrated nutrient management approach. Some people have also felt that the repackaging of inputs in small, affordable quantities, such as the PREP-PAC described in this paper, may be an avenue to attract smallhold farmers to use nutrient inputs. Nonetheless, crop responses to nutrient inputs vary widely within and across agroecozones (AEZs), suggesting specificity in recommendations. We highlight this observation in a case study whereby eight soil fertility management options, developed independently, are being tested side-

This article has been previously published in the journal "Nutrient Cycling in Agroecosystems" Volume 76 Issues 2–3.

A. Bationo (eds.), *Advances in Integrated Soil Fertility Management in Sub-Saharan Africa: Challenges and Opportunities*, 45–62.

© 2007 Springer.

by-side at on-farm level. Farmers will be empowered to identify technologies from their own choices that are agronomically effective and economically friendly. This approach of technology testing and subsequent adoption is recommended for technology development in future.

Introduction

It is widely known that variations in altitude, climate and soils largely influence agricultural productivity within and across countries in Africa. These variations have been used in the sub-divisions of croplands into agroecozones (AEZs) for management purposes in each country. Thus in the eastern African region, low maize (staple) yields are common in the coastal, medium altitude and moisture stressed regions, whereas high yields occur on the cooler high altitude and high rainfall areas (Table 1). Crop yields certainly are dependent on the management factors, but low yields are widespread on the highly weathered and nutrient depleted soils (e.g. Table 2 soils) in Africa, mainly the acrisols (ultisols), ferralsols (oxisols), nitisols

and luvisols (alfisols) (Woomer and Muchena 1996). In the studies of nutrient cycles at the continental (Sanchez et al. 1997), district (Smaling et al. 1997) and farm (Shepherd et al. 1996) scales, major nutrient (nitrogen, phosphorus, potassium) outflows far exceed inflows in a range of farming systems in most countries in Africa, resulting in the well-known negative nutrient balances.

These nutrient deficits (nutrient depletion) are reflected in the overall low and declining crop yields (Figure 1), suggesting long term food deficits and hence food aid in sub-Saharan Africa (see Table 3 for Kenya). Gachene and Kimaru (2003) have gone a step further to pinpoint soil related constraints that contribute to nutrient depletion, low land productivity and low crop yields in Africa; these are: low soil moisture, soil salinity

Table 1. Maize growing areas in Kenya by agro-ecozones (AEZs, after Ayaga 2003).

Growing area	AEZ	Altitude (m) a. s. l.	Area (×1000 ha)	Mean maize yield (t/ha)
Coastal zone	CL3/CL4	0–1000	100	1.36
Moisture-stressed	UM/LM	1000–1600	400	1.03
Non-moisture stressed (mid altitudes)	UM/LM/LH	1600–1700	400	1.44
High altitude late maturity	UM/UH	1700–2300	500	2.91
Very high altitude	UM	2300	100	2.76
Total	–	–	1500	–

Legend CL – Coastal lowlands 3 and 4.

UM and LM – Upper and Lower Midlands.

UH – Upper Highlands.

Table 2. Some properties of soils from maize growing areas in East Africa (after Okalebo, 1987).

Soil parameter	Medium to high altitude		Low altitude including ASALs	
	Mean	Range	Mean	Range
pH (0.01 M CaCl ₂)	5.15	4.64–5.72	5.14	4.56–6.10
Total N (%)	0.25	0.12–0.52	0.11	0.08–0.15
Total C (%)	2.5	1.1–4.0	1.0	0.8–1.4
CEC (cmol kg ⁻¹)	19.0	11.8–26.5	10.8	5.4–16.4
Olsen available P (mg kg ⁻¹)	40	17.3–54.1	21	9.2–40.7

Number of sites for medium to high altitude soils = 14.

Number of sites for low altitude soils = 10.

ASALs = Arid and semi-arid lands.

Note: Low N and C (organic matter contents), the CEC and the clay contents of the soils from the low altitude, including ASALs areas.

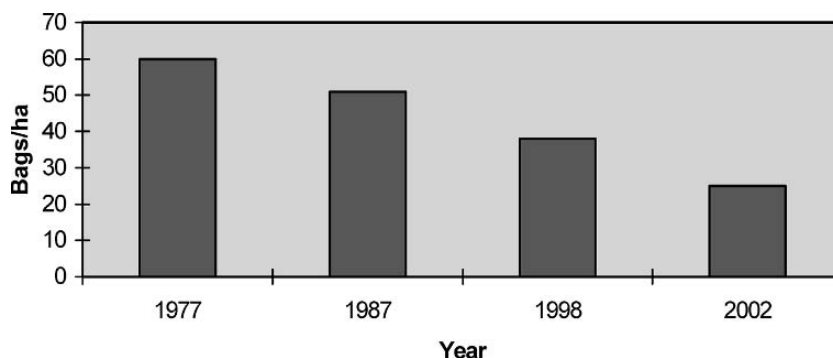

Figure 1. Maize yields in Trans Nzoia district (1977–2002). Source: Rev. (Nelson Kariuki (2003), CENART CONSORT NGO. Note: One bag weighs 90 kg of sun-dried maize grain.

Table 3. Projected deficits in the food commodities in Kenya in the year 2010 (after Ayaga 2003).

Commodity	Annual deficit (×1000 t)
Maize	864
Wheat	251
Rice	161
Vegetable oils	291
Sugar	100

and sodicity, soil compaction and formation of hard pans common in drylands. To improve agricultural productivity, rather extensive research efforts have been made in most areas in Africa to replenish the fertility of nutrient depleted soils. These include the diagnostic investigations to pinpoint nutrient limitations, the identification of both inorganic and organic inputs and their rates, times and methods of application, use of low cost inputs and the agroforestry based systems to recycle nutrients. Results from these soil fertility studies are enormous, but summaries by (Sanchez et al. 1997; Lwayo et al. 2001), Gichuru et al (2003) and Bationo (2004), are very useful.

In this paper, we highlight soil fertility management technologies developed and practiced in the East African region. We recognize the need for site-specific fertilizer or manure recommendations for major crops as a result of variability in the nutrient status of soils within and across croplands (Okalebo et al. 1992). We present case studies, which pinpoint the materials and their rates of application in soil fertility replenishment, together with the results obtained from technol-

ogies. We also recognize and highlight the economics impact on technology adoption in the East African region.

Our main objective in this paper is to expose and summarize a range of soil fertility management options, together with data associated with each option, which will empower the farmer to adopt a specific technology. It is envisaged that the review will guide researchers in their efforts to find the way forward towards soil fertility amelioration and enhanced food security.

Early studies on soil fertility replenishment in East Africa

Crop responses to inorganic fertilizers

The constraint of soil fertility depletion was probably appreciated in most African countries from about 1950s to date. Before this period, shifting cultivation was widely practiced, whereby the bushy to forest lands were cleared and cropped until yields fell; the farmers then moved to other bushy lands and thereby allowed the exhausted land to rebuild fertility through long fallows (e.g. Cooke 1967; Greenland 1974). This shifting cultivation practice is still used in the forest lands in Central Africa and Nigeria, where bushes and forests are slashed down and burnt to facilitate cultivation (Gichuru et al. 2003). However, as a result of population pressures from about 1980s to date, particularly in the eastern African region, land has been cultivated continuously with negligible to no nutrient returns to land (Smaling et al.

1997; Swinkels et al. 1997), resulting in soil fertility depletion constraint outlined above. In this subsection, we summarize results from diagnostic efforts to detect nutrient limitations in soils and solutions to correct these constraints, using mainly the inorganic resources.

Thus, laboratory analysis of soils (Birch 1952; Stephens 1961; Uriyo et al. 1976) and pot tests (Pinkerton 1958; Butters 1961) have been widely used in East Africa to detect nutrients limiting plant growth, while field trials (a few selected and presented in Table 4) have confirmed the nutrient limitations from the laboratory and pot tests. However, the common feature of these early trials is that they indicate wide responses to applied nitrogen (N) and phosphorus (P) fertilizers, but give limited to no economic based recommendations for fertilizer types and rates.

In the early study approach, experimentation varied widely among researchers and the AEZs including soils, sites, and soil characterization was minimal. Types and rates of fertilizer N and P also varied significantly, influencing responses to a wide variety of crops (mainly the cereals). Limited economic analyses in only cost to value ratios were done.

This early study approach has mainly contributed to blanket kind of fertilizer recommendations, for example, the 60 kg N + 26 kg P/ha recommended for maize in many parts of Kenya,

irrespective of factors such as soil type, rainfall regimes and cropping history. From 1990s to date, there has been a shift in research to restore soil fertility in the eastern African region. Tasks have delineated the need to identify specific nutrient limitations within and across fields in a farm (Okalebo et al. 1992; Ikombo et al. 1994; TSBF 1994). This approach permits the narrowing down or the reduction of treatments needed for specific crop responses for the specific area. It also targets the production of packages for target areas, such as the PREP-PAC package (described later in this paper) that replenishes the fertility of seriously depleted patches in a field.

In another development, the organic resources that are commonly available and therefore widely used by the African smallhold farmer to restore soil fertility have been characterized with respect to their quality Woomer et al. 1994a; Probert et al. 2004). The outstanding results are that the organic materials vary widely in quantity and quality (nutrient, lignin and polyphenolics contents) as illustrated in Table 5. The materials are generally very low in quality (compared to inorganic materials). But TSBF suggests the direct use of the organic resources containing total N levels above 2.5% N, towards the affordability constraint (Palm et al. 2001).

In addition to low cost organic materials, short duration fallows (e.g. sesbania, tephrosia,

Table 4. Crop responses to inorganic fertilizers from selected field trials.

Source	N and P rates	Crop	Response
<i>Kenya (1970–1994)</i>			
Gathecha (1970)	50–500 kg P/ha SSP	Sorghum, wheat, maize	+ ve
Vadlamudi and Thimm (1974)	174 kg N + 105 kg P/ha TSP	Maize	+ ve
Allan et al. (1972)	170 kg N + 26 kg P/ha DAP & TSP	Maize	Economical + ve
Allan et al. (1972)	60 kg N + 26 kg P/ha TSP	Maize	Economical
FURP (1994)	75 kg N + 26 kg P/ha TSP	Maize	Economical
Probert and Okalebo (1992)	60 kg N + 20 kg P/ha TSP	Maize	Economical
<i>Tanzania (1963–1984)</i>			
Evans (1963)	50–100 kg P/ha TSP	Maize and groundnuts	+ ve
Anderson (1970)	50 kg P/ha DAP	Maize	+ ve
Marandu et al. (1973)	40 kg P/ha TSP	Maize	+ ve
Mongi et al. (1974)	100 kg N + 40 kg P/ha TSP	Rice	+ ve
Ngatunga (1964)	40 kg N + 44 kg P/ha TSP	Maize	Economical
<i>Uganda (1967–1973)</i>			
Stephens (1967)	100 N + 85–225 kg P/ha TSP	Maize and groundnuts	+ ve
Foster (1973)	ON + 11 kg P/ha SSP	Wheat	Economical
Foster (1973)	53 N + 25 kg P/ha SSP	Maize	Economical
Shumaker and Ogolle (1967)	100 kg N + 22 kg P/ha TSP	Sorghum, millet	+ ve
Starks et al. (1971)	100 kg N + 22 kg P TSP	Sorghum	+ ve

Table 5. Nutrient contents of commonly available organic resources among smallhold farmers in Central Kenya. (Woomer et al. 1999a).

Resource	Nutrient content (% dry matter)				
	N	P	K	Ca	Mg
Napier grass	1.02	0.11	2.63	0.35	0.06
Maize stover	0.89	0.8	2.78	0.41	0.18
Bean trash	1.20	0.13	2.06	0.89	0.16
Cowpea trash	0.57	0.05	1.79	0.81	0.08
Pigeon pea prunings	1.33	0.10	1.02	0.37	0.09
Sweet potato vines	2.27	0.14	3.05	1.32	0.53
Cattle boma manure	1.40	0.20	2.38	0.39	0.27
Poultry manure	3.11	0.42	2.40	0.82	0.42
Goat/sheep manure	1.48	0.20	3.31	0.94	0.42
Domestic compost	1.34	0.20	1.82	0.39	0.22

crotalaria), have been identified and tested by ICRAF to recycle nutrients and to add the most limiting N nutrient to soils through the biological nitrogen fixation (BNF) process and also through incorporation of their biomass into soils (Jama et al. 1997; Ndungu et al. 2003) and subsequent N release.

In the presentation of soil fertility management options used to replenish soil fertility in Eastern African region, the resources, together with their qualities and quantities, are given, focussing their uses to improve and sustain crop yields under the widely practiced maize–legume intercrops, banana and agroforestry cropping systems in the region. A few recently developed managements will highlight the impact of economic analysis/data designed to show profits or losses arising from using specific soil fertility options. It is felt that profitability is a good indicator towards the adoption process of technologies, particularly to the smallhold farmers who constitute over 80% of the farming communities in the developing world. The options now follow.

The impact of organic resources on soil fertility restoration

Addition of organic materials to soil is known to improve the chemical, physical and biological properties that will enhance the availability of nutrients and their uptake by crops.

In Table 5, a wide range of organic resources at farm level have divergent qualities and these materials will decompose and release different

quantities of nutrients in soils at different times (Gachengo et al. 2004), reflecting differences in nutrient availability and overall crop yields from each resource.

High quality materials, such as poultry manure, will therefore mineralize more readily in soils compared to low quality materials such as maize stover. Nonetheless, the mineralization and nutrient release patterns of low quality organic resources may be manipulated through incorporation of inorganic or through decomposition through the composting process (Muasya et al. 1996). This background information is supported by the findings from specific composting and soil fertility restoration tasks carried out in Kenya and Uganda, now described.

Crop responses to inorganic resources

The role of manure for improving soil fertility with reference to ASALs

In the ASALs, water (soil moisture), nitrogen and phosphorus significantly limit crop productivity (Keating et al. 1992). Surface management technologies in these fragile areas and soils have been suggested and tested to enhance moisture and nutrient storage for their efficient utilization, with positive results (Probert and Okalebo 1992).

Manures provide both N and P and other nutrients, but they are present in less soluble forms than in inorganic fertilizers. The crop response obtained will therefore, depend upon the deficiencies that occur in the soil and the rate at which nutrients in the manure are made available.

In studies carried out by J. R. Okalebo (unpublished data), an attempt was made to separate the effects of N and P by including treatments that compared their effects (alone or combined) with those obtained with poultry manure and farmyard manure (FYM) available at farm level. However, there were only single rates of application of each fertilizer material (due to field size limitations at on-farm level). The results from these on farm sites were similar and the means are presented in Table 6. In no instance was the response to separately applied N or P significant, making it impossible to determine which of the nutrients in the manure caused the responses. When N and P were applied together, yields were similar to those obtained with the FYM and poultry manure.

Table 6. The effects of fertilizers and manures on the yield of maize grain (kg/ha) averaged over three ASAL sites in eastern Kenya (Probert and Okalebo 1992).

Treatment	First season 1979	Second season 1979	
		With fresh application of fertilizer	Initial application only
Control	2.34	1.51	1.34
CAN (60 kgN/ha) ^a	2.38	1.33	1.05
TSP (40 kg P/ha) ^a	2.23	1.77	1.43
CAN + TSP	3.21	1.88	1.39
FYM ^b	3.08	2.21	1.77
Poultry manure	4.00	1.97	1.79
SE	(1.09)	(0.91)	(0.95)

^a Sources of N and P were calcium ammonium nitrate (CAN) and triple superphosphate (TSP)

^b The FYM used was not the same at all sites. Rates of N and P applied (kg/ha) in the FYM treatment were: at Kathonzweni and Kampi ya Mawe sites (Kenya) were 103 N and 44 P, at Kimutwa site 215 N and 49 P.

The poultry manure applied was 106 N and 58 P (based on chemical analysis of materials).

Residual effects following a single application of the fertilizer materials tended to be greater for the manures than in the organic sources, but yields were below what could be achieved with fresh application of the manures. Nevertheless, the nutrients responsible for residual effects are not necessarily the same as those causing responses when freshly applied.

This experiment was confounded by many variables. Nonetheless, it gives an insight on complexities involved in handling organics with different qualities. In practice, farmers apply moist manures (some not completely decomposed) in measures of handfuls/planting hole or in wheelbarrow loads (Probert et al. 1992).

Use of water hyacinth (Eichornia crassipes (Mart.) Solms) as an organic input to soils in Uganda

In Uganda, bananas (*Musa*) are grown on a wide range of soils, but mainly on the degraded ferral-sols along Lake Victoria basin. Apart from soil moisture conservation, the mulches (mainly from banana residues) also provide nutrients to growing bananas. Thus banana yield increases have been obtained from retention of crop residues and addition of 10 t/ha of napier grass or as cattle manure (Woomer et al. 1999b).

The invasion of water hyacinth into lakes, and rivers of East Africa has forced the implementation of mechanical clearing around the shores and dams, resulting in difficulties of waste disposal, particularly on crowded areas (Amoding et al. 1999). Water hyacinth therefore, presented an

opportunity to apply organic inputs to agricultural soils of low inherent fertility. Part of the study on the utilization of the water hyacinth examined the composting of wastes as a means of concentrating plant nutrients and the consequent growth response to the compost by the high value cabbage crop. Water hyacinth has been used as a soil additive to agricultural systems as mulch and compost, for example as mulch to tea estates in India (Gopal 1987). Earlier investigations along the shores of Lake Victoria in Uganda indicated that when water hyacinth is applied as mulch, it offers an opportunity as an organic input to soils because of its high nutrient contents and its rapid decay pattern (Amoding et al. 1999). An estimate of 209 t of N is contained in water hyacinth recovered through mechanical clearance at the Owen Falls Dam in Jinja, Uganda. Further, the compost made from water hyacinth contains higher major nutrients than that prepared from cattle manure (Heider et al. 1984).

Composting concentrates nutrients and hence reduces transportation costs of the high water (92%) containing fresh water hyacinth. Results of an experiment where the benefits of fresh and composted water hyacinth were compared as organic inputs to degraded soils around Lake Victoria in Uganda are summarized here. Compost was prepared from dewatered, chopped water hyacinth using the pit method. Composting resulted in an increase in the N content.

The effects of the compost were compared with those of fresh water hyacinth applied as either

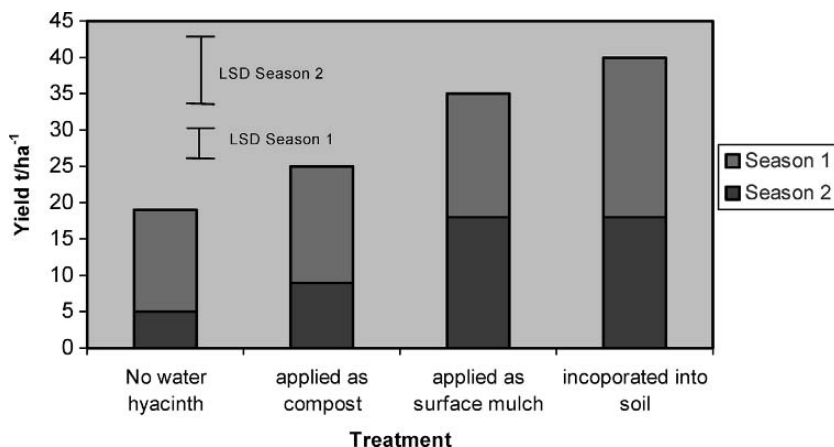

Figure 2. Effect of water hyacinth amendments on cabbage yield (Amoding et al. 1999).

mulch or incorporated into the soil and to a control receiving no inputs (Figure 2). When the costs of chopping and application are considered, fresh water hyacinth wastes give higher benefits than the composted wastes (Amoding et al. 1999). This organic input will continue to be available as long as it keeps on moving across Lake Victoria.

Use of wheat straw, soybean trash and nitrogen fertilizer for maize production in the Kenya Highlands

Making best use of available crop residues is an important component of integrated nutrient management. In the wheat growing areas of Kenya, wheat straw, yielding up to 15 t/ha, is left in the fields and burnt to facilitate land cultivation for the succeeding season. A field study was conducted over two seasons (1997 and 1998) in Kenya (Uasin Gishu district) that examined use of wheat straw, soybean trash and N fertilizer as nutrient inputs for maize production. The organic inputs were applied at the rate of 2 t/ha per season and urea was added at rates of 0, 20, 40, 80 and 100 kg N/ha in an incomplete factorial treatment structure that also included a complete control (no inputs) and 80 kg N/ha as urea without organic inputs. Urea was meant to enhance the decomposition of wheat straw. Rate of 2 t/ha straw as chosen not to cause N immobilization when incorporated into soils.

Maize grain yield ranged between 0.75 and 6.84 t/ha in 1997 with lowest yields observed in the treatment receiving wheat straw alone, and higher yields associated with soybean residue incorpora-

tion. There was benefit from more favourable rainfall, providing grain yield increase of 141% above control treatment as a result of combining 2 t/ha soybean trash and 100 kg N/ha urea (Table 7).

The generally high yields from soybean trash are explained in terms of higher quality, faster decomposition and nutrient release compared to lower quality wheat straw. A positive effect in increases of soil pH, C, N, and P status as a result of cumulative use of crop residues was observed.

Larger yields were obtained when organic and inorganic inputs were applied together to soils,

Table 7. Effect of continued application of crop residues and nitrogen fertilizer on maize grain yield (t/ha) in a Chepkoiel ferralsol, Eldoret, Kenya (after Okalebo et al. 1999).

Treatment	1997	1998
Control	0.87	2.83
80 N	1.02	4.88
WS + ON	0.96	2.05
WS + 20 N	1.32	2.93
WS + 40 N	1.30	3.22
WS + 80 N	1.67	4.79
WS + 100 N	1.68	5.47
SYT + ON	0.75	2.83
SYT + 20 N	1.47	2.50
SYT + 40 N	1.44	3.71
SYT + 80 N	1.50	5.57
SYT + 100 N	1.88	6.84
LSD ($P = 0.05$)	555	1030

NB: WS, Wheat straw; SYT, soybean trash.
N, nitrogen applied as urea at 0, 20, 40, 80 and 100 kg N/ha.

particularly when soil moisture was adequate and from addition of organic inputs higher in mineralisable nutrients. These findings suggest that better use may be made of crop residues than the burning following harvest as is currently practiced by many farmers in this wheat growing area of western Kenya (Okalebo et al. 1999). Added N enhances straw decomposition and N release.

Using a wide range of organics and inorganics to replenish soil fertility in central and eastern highlands of Kenya

Like most African countries, soil fertility depletion largely accounts for low and declining crop yields in eastern and central highlands of Kenya.

Use of inorganic fertilizers in this region is generally low, below 20 kg N and 10 kg P/ha (Muriithi et al. 1994). This amount of fertilizer is inadequate to meet crop nutrient requirements for optimum crop yields at on-farm level. Over 80% of the smallhold farmers use farmyard manure (FYM) to improve soil fertility and crop productivity. Maize yields at farm level hardly exceed 1.5 t/ha (Wokabi, 1994). Positive crop yield increases have been reported as a result of applying the biomass of tithonia, calliandra and leucaena for soil fertility improvement (Gachengo et al. 1999; Mutuo et al. 1998).

These materials needed evaluation in the field particularly for demonstration purpose to smallhold farmers. The demonstration used was researcher–farmer managed in Meru area, Kenya. A

wide range of organic resources (mainly agroforestry shrubs/trees and manures) was compared through their incorporation into soils at an equivalent rate of 60 kg N/ha, the rate considered economical for optimum maize growth and yield in the candidate areas. The organics were also combined and incorporated into soils with inorganic compound fertilizer (23–23–0) at 30 kg N/ha, while the other 30 kg N/ha was obtained from the specific organic sources. Detailed experimentation is described by Mugendi et al (2001). The trial was conducted in two seasons in the year 2000. Maize grain yields obtained are presented in Table 8. Very low yields in the first season are explained in terms of low rainfall (total 126 mm) in that season compared to high yields in the second season, with a total rainfall of 698 mm.

Overall, the results of two seasons from this trial indicate that maize performance may be improved by combining fast decomposing plant biomass and half the recommended rate of N. Tithonia biomass with half of N (30 kg N/ha) gave the best results (6.4 t/ha) of maize grain in two seasons, followed by sole tithonia biomass (6.2 t/ha) then cattle manure with half the recommended rate of inorganic N (6.1 t/ha). The crotalaria gave the lowest yields (2.5 t/ha).

In this study the sole mucuna treatment had the highest benefit cost ratio of 4.1, followed by sole leucaena, sole crotalaria and sole tithonia. The recommended rate of inorganic N gave the lowest benefit–cost ratio of 1.6.

Table 8. Maize yields (t/ha) under different soil fertility amendments in Meru, Kenya.

Treatment	First rains 2000	Second rains 2000	Total
Control	0.8	3.6	4.4
Mucuna 60 kg N/ha	1.2	3.1	4.3
Crotalaria 60 kg N/ha	0.9	1.6	2.5
Mucuna 30 kg N + 30 kg N/ha	1.4	3.7	5.1
Crotalaria 30 kg N + 30 kg N/ha	1.0	3.6	4.6
Cattle manure 60 kg N/ha	0.9	4.9	5.8
Tithonia 60 kg N/ha	1.2	5.0	6.2
Calliandra 60 kg N/ha	0.7	4.5	5.2
Leucaena 60 kg N/ha	1.0	4.6	5.6
Cattle manure 30 kg N + 30 kg N/ha	1.2	4.9	6.1
Tithonia 30 kg N + 30 kg N/ha	1.3	5.1	6.4
Calliandra 30 kg N + 30 kg N/ha	1.0	4.4	5.4
Laucaena 30 kg N + 30 kg N/ha	1.3	4.5	5.8
60 kg N/ha (inorganic)	1.4	4.7	6.1
Mean	(1.1)	(4.2)	
SED	0.2	1.2	

(Source: Mugendi et al. 2001).

Table 9. Estimated resources of important phosphate rocks (PRs) in East Africa (after Buresh et al. 1997; Van Kauwenburgh, 1991).

Country	Name of deposit	Type of PR	Reactivity	Estimated reserves (10 ⁶ tonnes)	Total P content (g/kg)
Tanzania	Minjingu	Sedimentary	Medium to high	10	87–109
Tanzania	Panda Hill	Igneous	Low	125	26
Uganda	Sukulu Hill	Igneous	Low	230	48–57
Kenya	Rangwe	Igneous	Low	–	< 48

Nutrient replenishment using low cost phosphate rock and the biological nitrogen fixation process

Phosphate rocks

Phosphate rocks (PRs) have been used directly over a long period in Africa to improve the P status of soils and hence increase crop yields. Thus in the eastern African region different kinds of PRs are found with different parent rock origins, qualities and quantities in terms of P contents (Table 9).

About 51,000 tonnes of Minjingu PR (MPR) were mined in 1995. Total P contents of this PR vary rather widely. Currently the KEL Chemical Company in Thika, Kenya, imports MPR for the manufacture of single superphosphate for the Ugandan Market mainly and for direct use on coffee, tea and other crops (Paul Mwaluko, personal communication).

Effectiveness of these PRs in relation to crop yields in the eastern, central and southern African regions is generally around 69% compared to that of refined or soluble triplesuperphosphate (TSP) (Okalebo and Woomer 1994). But notably the biogenic/sedimentary MPR has attained 114% effectiveness compared to TSP on the acid and low P status soils of western Kenya (Buresh et al. 1997; Nyambati 2000). This level of effectiveness of MPR was found in the ICRAF experiments on acid and low P soils whereby a one-time replenishment of MPR at 250-kg P/ha was compared with annual MPR applications at 50 kg P/ha. Similar TSP addition rates were used for comparisons.

Using the PREP-PAC¹ technology to restore the fertility of depleted soils

Following the evidence above on the effectiveness of MPR on acid and low P soils, a package, PREP-

PAC, was developed at Moi University, Eldoret, Kenya, in 1997, designed to replenish the fertility of soils on seriously depleted patches that are widespread on smallhold farms. PREP-PAC consists of 2 kg MPR, 0.2 kg urea, 120 g food legume seed, rhizobial inoculant (Biofix) packed with lime pellets to raise the pH of the inoculated seed environment and gum Arabic sticker to hold the inoculant onto the surface of the seed and instructions for use written in English, Kiswahili and local dialects. One packet is designed to replenish soil fertility of patches of size 25-m² (Nekesa et al. 1999).

Since 1997 on-farm trials have been conducted in western Kenya and eastern Uganda to test the effectiveness of PREP-PAC with respect to crop yields and economic considerations; these experiments are:

On-farm testing of PREP-PAC

Through the researcher-NGO-farmer contact, the target soils for replenishment were:

- (i) Acrisols with sandy surface horizons and very low soil fertility (common in Siaya and Busia districts, Kenya).
- (ii) Acrisols with clay surface horizons and low to moderate inherent soil fertility (common in Bungoma and northern Kakamega districts, Kenya).
- (iii) Acrisols/ferralsols complexes with moderate to high clay contents, but now depleted inherent soil fertility (common in Vihiga and Kakamega districts, Kenya).

PREP-PAC was tested on smallhold maize-legume based intercropping systems in the depleted soils and districts above in western Kenya and some packs in eastern Uganda. Soils at the study sites had generally low soil fertility (Table 10) and the farmers considered these the most fertility-depleted areas of their farms (Nekesa et al. 1999).

¹PREP stands for Phosphate Rock Evaluation Project

Table 10. Selected soil (0–20 cm) chemical properties for 52 farms in western Kenya (Nekesa et al. 1999).

Soil property	Minimum	Maximum	Mean	Sd
pH (H ₂ O)	4.68	7.26	5.44	0.52
% N	0.15	0.49	0.32	0.08
% C	0.38	4.20	1.89	0.81
Olsen P (mg/kg)	1.00	7.50	2.40	1.50

PREP-PAC input was provided to 52 farmers in western Kenya and the prescribed application procedure explained. All farm operations, including application, plant disease/pest control were done by the farmers. Two adjacent plots each measuring 25 m² were marked and treatments applied to one plot. Inoculated bean seed and maize were planted immediately. Control plots were beans and maize intercropped with no PREP-PAC inputs.

Treatments were designed to compare economic returns to PREP-PAC with no fertility amendment practices in the bean–maize intercrops. In both treatments farmers planted the same maize variety of the farmers' choice and either climbing (cv Flora) or bush variety of *Phaseolus vulgaris* contained in the PREP-PAC. Farmers managed the experiment (including the trials in eastern Uganda).

After harvest, sun-dried weights of maize and bean grains from two plots at each farm were taken. Statistical analysis of crop yield and economics data was done on the computer using SYSTAT package and FREELANCE package for the graphics. Maize yields were lowest in the unfertilized (control) plots with a mean farm yield of 0.64 t/ha. PREP-PAC application increased maize yield to a mean of 1.36 t/ha. PREP-PAC application to soils of pH < 5.2 improved bean yield from 25 to 125 kg/ha. This is obviously a very low bean yield. Nonetheless, this low pH level favours the dissolution of phosphate rock in soils. At the pH < 5.2, climbing beans (cv Flora) yielded 200 kg/ha on the control plots and the PREP-PAC yield was 350 kg/ha. Economically, use of PREP-PAC in soil pH < 5.2 increased financial return on land from Ksh. 8720 to Ksh. 19,920/ha, with a return ratio of 1.27 (Woomer et al. 2003a).

Testing the effectiveness of components of PREP-PAC

The performance of PREP-PAC components and their interactions were tested at three on-farm sites

with low soil fertility in western Kenya (Obura et al. 1999). This region is also characterized by having two cropping seasons annually. Thus a 2×2×2 factorial arrangement of MPR, Urea and inoculant (at 2 levels each) treatments was used in this experiment (with treatments applied in a randomized complete block design with four replications). Plot size was 25 m², reflecting the target areas for replenishment using one PREP-PAC. Treatments determined the response of maize and N-fixing soybean intercrops to individual components of the pack (MPR, Urea and Biofix) and the interaction of various components of the Pack (rock P + Urea, rock P + Inoculant, Urea + Inoculant, and rock P + urea + inoculant).

MPR (2 kg) and urea (0.2 kg) were broadcast and incorporated to 0–15 cm seedbed at planting. Soybean seeds (cv Black Hawk) were inoculated for specific treatments for planting. Maize was planted and the standard crop husbandry practices maintained. Maize grain yields for one season (first rains 2001) are presented in Table 11. Thus, the main PREP-PAC components (PR, urea and Biofix) applied individually increased maize yields across the three sites, but particularly so in Kakamega with red soil of a high clay content, where a grain yield increase of 162% above control treatment was found. The complete pack (PR + Urea + Biofix) gave the largest yield increase of 205% above the control in Siaya.

Positive economic returns to investment from individual PREP-PAC inputs and their combinations are reported elsewhere (Obura et al. 1999, Woomer et al. 2003a).

Marketing of PREP-PAC

For continuity of acquisition of components of the pack, a marketing study (Mwaura 2002) was conducted whereby the stockists and retailers of agricultural inputs in western Kenya were asked to sell the pack. Selling prices varied widely with farmers able to offer low prices (Figure 3). Economic studies on acquisition of inputs, repackaging, sales and profits need to be continued.

Extended use of Minjingu phosphate rock (MPR) for soil fertility improvement in Kenya

In our presentation on the use of PREP-PAC, we highlighted the MPR as being its major compo-

Table 11. Maize grain yield from three farms in western Kenya under maize - soybean intercrop (Obura, 2001).

Treatment	Grain yield (t/ha)		
	Siaya	Bungoma	Kakamega
Control	1.58	1.62	1.60
Biofix	2.23	1.25	2.26
Urea	1.93	1.18	2.61
MPR	2.51	2.44	4.17
Urea + Biofix	2.28	1.08	2.89
MPR + Biofix	2.93	2.41	2.95
MPR + Urea	3.74	3.03	2.30
MPR + Urea + Biofix	4.81	2.71	3.15
SED (trt)	(0.74)	(0.48)	(0.65)
LSD (<i>P</i> = 0.05)	1.53	(0.99)	1.35
cv (%)	26	24	24

MPR, Minjingu Phosphate Rock.

ment and we also stressed its applicability for amelioration of soil fertility in the worst patches in the fields, focussing the increase in yields of maize–legume intercrops (mainly beans and soybeans).

However, as indicated earlier, MPR is generally effective on acid and low P and Ca soils. Several researches have tested the effectiveness of MPR on a range of crops, including the agroforestry – short or improved fallows. Thus in a field study by Ndungu et al (2003) the use of low cost technology utilizing MPR as a P source to enhance the growth and yield of maize – short fallow intercrops on nutrient depleted soils, also aimed at the provision of low cost N to succeeding maize crops through the N fixed by the legume fallows (crotalaria and tephrosia) and through the fallow biomass

decomposition and N release in soils. Apart from soil fertility replenishment, the fallows tested have also other uses, such as the provisions of poles, fuelwood and pest control (tephrosia). Three on-farm trials in Busia, Siaya and Bungoma districts, Kenya, tested the effectiveness of MPR (at 0, 20, 40, and 60 kg P/ha) on the yields of maize – fallow intercrops in the first cropping season of MPR incorporation.

In the second season, the effect of chopped fallow biomass incorporation with residual MPR, was monitored in relation to the release of mineral N (Table 12) through fallow biomass decomposition 16 and 32 weeks after maize planting (WAP) and the interaction with MPR. Maize yields were also obtained in the second season (Table 13). Treatments significantly increased NO₃-N levels in soils in all three sites, as shown for Siaya site (Table 12). Levels of nitrate in soils also increased with cropping period from 16 to 32 WAP, reflecting the availability of N over a long period during maize cropping.

In the first season, the treatments further significantly increased maize yields in all sites as given in Table 13 for Siaya. Low and insignificant grain yield increase in the second season is attributed to low and poorly distributed rainfall. Nonetheless, the net benefit and return to land from applying different rates of MPR varied with site. The highest net benefits were found in Bungoma site in the maize–bean rotation system when MPR was applied at 60 kg P/ha, giving the return to land values of Kshs. 15,758 over the two seasons. It is to be noted that due to a longer maize growing season in Bungoma (coolest site), only beans were planted at this site in the second season. This obviously raises the question of labour in relation to chopping and incorporation of fallow biomass ready for second season planting. There is a short period between harvesting of first maize crop and planting the second maize crop.

Nevertheless, MPR is effective on replenishing soil fertility for production of a wide range of crops, including short fallows, that will eventually provide additional N input to cropping systems. In a separate/parallel study by Kifuko et al (2003), chicken manure and maize stover mixed with MPR and incorporated into the seedbed significantly increased maize yields, raised the available P levels in soils and reduced P sorption in the same ferralsol of Siaya site.

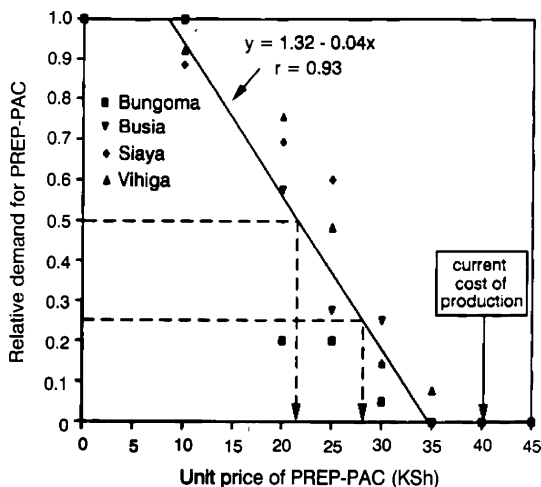

Figure 3. Market testing of PREP-PAC (after Mwaura, 2002).

Table 12. Effect of MPR and short fallow biomass incorporation into (0–15 cm) soils on NO₃-N during maize growth in Siaya (Kenya) site ferralsol, second season (Ndungu et al 2003).

MPR (kg/ha)	Sampling time, weeks after maize planting (WAP)					
	16 WAP			32 WAP		
	Crotalaria	Tephrosia	Mean	Crotalaria	Tephrosia	Mean
0	9.3	5.8	7.5	13.4	12.1	12.7
20	10.7	9.9	10.3	17.0	14.2	15.6
40	9.1	13.2	10.2	17.8	23.8	20.8
60	11.4	8.9	10.2	16.2	18.1	17.1
Mean	10.1	9.5	9.8	16.1	17.0	16.6

No statistical analysis was done on NO₃-N data, due to limited laboratory analytical facilities and hence composite samples from each of four replications for treatment were analyzed.

Replenishment of phosphorus in depleted soils in Tanzania using MPR

A comprehensive review by Semoka and Kalumuna (1999) on MPR research work conducted in Tanzania from 1960s has shown that MPR has agronomic effectiveness. Under favourable conditions of low soil pH, phosphorus, and calcium status of soils and high rainfall, MPR is as effective as the inorganic P fertilizers such as triplesuperphosphate. However, in most cases, conventional fertilizers were found to be better than MPR in the first year/season of application, but in subsequent seasons the effectiveness of MPR increased. Generally, from the third year of application onwards, the yields obtained from MPR addition were

higher than those obtained from conventional fertilizers (Semoka and Kalumuna 1999). In any case, research with MPR has been limited in Tanzania to a few crops grown mainly in the sub-humid areas. Mkwangwe (2003) recognized the stated declining soil fertility status, the changing climate, and the new crop varieties with high nutrient demands, and thus carried out trials in the drier parts of central Tanzania to examine the effect of MPR from its direct and residual additions on the yields of the widely cultivated groundnuts and maize in that area and also compared the residual effects of MPR and TSP applications on maize yields.

Table 14 shows the groundnut yields obtained from six consecutive cropping seasons in central

Table 13. Effect of MPR and short fallow biomass incorporation into 0–15-cm ferralsol of Siaya (Kenya) on maize grain yields (t/ha) in two seasons (Ndungu et al 2003).

MPR (kg/ha)	First season			Second (successive) season		
	Fallow species			Fallow species		
	Crotalaria	Tephrosia	Mean	Crotalaria	Tephrosia	Mean
0	1.45	0.71	1.08	1.11	1.17	1.14
20	3.23	2.26	2.74	1.21	1.84	1.52
40	2.34	2.76	2.55	1.38	1.61	1.50
60	3.63	3.32	3.50	1.55	1.63	1.59
Mean	2.66	2.27	2.47	1.31	1.56	1.44
SED (P)	0.51			NS		
SED (F)	NS			NS		
SED (P × F)	NS			NS		

SED (P), Standard error of deviation for P rates.

SED (F), Standard error of deviation for fallow biomass.

SED (P × F), Standard error of deviation for interaction between P rates and fallow species biomass.

Table 14. Effect of MPR and TSP on seasonal groundnut kernel yield (t/ha) in central Tanzania (adapted from Mkangwe 2003).

P source and rate (kg/ha)	Season					
	1	2	3	4	5	6
Control	178	375	536	511	281	231
MPR, 13.2	112	550	703	857	321	309
MPR, 26.4	101	558	639	957	358	263
TSP, 13.2	134	415	669	918	319	267
LSD ($P = 0.05$)	NS	125	NS	NS	NS	NS

semi-arid Tanzania. Groundnut yields were lowest in the first season of MPR and TSP application due to low rainfall, and were highest in the fourth season with treatments increasing the yields which, subsequently declined in the fifth and sixth seasons. Maize yields (not reported here) were also raised by MPR application up to the third cropping season. This shows the positive or residual effect of MPR.

Towards the adoption of soil fertility replenishment technologies

The case studies presented in this paper have demonstrated positive effects of soil fertility management technologies across East African countries, using a wide range of inorganic and organic resources and packages, particularly of low cost materials. Monetary gains resulting from use of various technologies have also been reported. But in spite of demonstrations and appreciation of technologies, Africa is faced with a problem of negligible to nil adoption of technologies in general. The most obvious response is the constraint of expensive agricultural inputs. In one of the attempts to enhance technology adoption, we report preliminary results of field trials that are being conducted in western Kenya under the rare situation of researcher – NGO (Extension) – small farmer co-operation.

In this endeavour, it is recognized that many existing soil fertility management technologies have been developed on an individual or institutional basis and these technologies have rarely been compared side-by-side on their performance. Thus from 2002 (to date) field trials have been

installed on 140 smallhold farms across seven districts in western Kenya with varying climate, altitude and soils (Woomer et al. 2003b).

The main objective is to compare the effectiveness and the 'acceptability' of eight soil fertility management options across these farms. One NGO (SACRED Africa) is leading this study with other six NGOs collaborating very closely in the studies. Kenyatta and Moi Universities, Kenya, participate in backstopping (Woomer et al. 2003b).

The guiding principle in the study is the need to compare all existing soil fertility amelioration options side-by-side. It is also believed that farmers will accept profitable options that are labour friendly. In the study, the maize-legume widespread intercropping system was adopted, with farmers managing the trials with the advice of the NGOs. The technologies under test consist of the use of organic and inorganic resources applied individually or in combinations, the use of agroforestry short fallow species and the legume cover crops designed to recycle nutrients and the testing of the newly introduced PREP-PAC and MBILI (staggered two maize and two legume spacing) options. The NGOs selected the farmers who participated and executed all field operations.

Treatments/technologies were:

- The absolute control, representing no nutrient inputs from smallhold farmers.
- Farmers' practice where any form of manure, compost or inorganic fertilizer is applied at varying rates (estimated at 15 kg N + 17 kg P/ha as DAP in Bungoma district, but at 4 t/ha FYM in some districts.
- Organic farming community treatment with biogenic MPR fortified wheat straw or maize stover compost developed at Moi University, Kenya, applied at 2 t/ha (44 kg N + 8.5 kg P/ha).
- PREP-PAC package (as above), this is an input of 100 kg P/ha + 40 kg N/ha urea + Biofix (rhizobial inoculant), also developed at Moi University).
- Mineral fertilizer, the KARI/FURP (1994) treatment consisting of 75 kg N/ha CAN or urea + 20 kg P/ha TSP (or DAP).
- Mineral fertilizer for MBILI package (staggered row intercropping with inputs of 31 kg

Table 15. Soil test data (at preplanting in 2002). Before the installation of Best-Bets Experiment in 7 districts in Western Kenya (means for 20 farms per district).

District	Soil test			
	pH (H ₂ O)	%C	%N	Olsen P (mg)
Bungoma	5.54	1.37	0.18	4.8
Busia	5.13	1.00	0.27	4.0
Teso	5.73	0.72	0.09	6.6
Trans Nzoia	5.26	2.01	0.27	3.5
Vihiga	4.84	1.23	0.16	3.3
Siaya	4.82	1.67	0.18	3.6
Homa Bay	6.79	2.29	0.43	19.7
Means	(5.44)	(1.47)	(0.23)	(6.5)

Note:

- (1) Particularly low available P levels in the soils.
- (2) Soils are mainly acrisols, ferralsols (vertisols in Homa Bay) of a sandy to clay texture (in Homa Bay).
- (3) Soils are generally acidic and of low organic matter content.

N + 20 kg P/ha (DAP at planting but CAN as a topdressing). MBILI = Managing Beneficial Interactions in Legume Intercrops.

- ICRAF's maize-bean-crotalaria short fallow intercropping system designed to supply upto 200 kg N from the biological nitrogen fixation (BNF) process (fixed by crotalaria), through legume biomass incorporation into soils and nutrient deep root capture.
- Legume cover crop maize cropping, with Lablab (dolichos) incorporated into soils supplying mainly N. No other external inputs were applied to the fallow and to Lablab relay crops.

Table 16. Yields (t/ha) of maize and legumes from soil fertility managements (Best Bets) in western Kenya during two cropping seasons of 2002 (the researcher-NGO-farmer co-operation; after Woomeer et al. 2003b).

Soil fertility management	Long rains		Short rains		Cumulative (ksh.)	
	Maize yield	Legume yield	Maize yield	Legume yield	Total costs	Net returns
No inputs	1.95	0.19	0.51	0.14	14515	12036
Farmers practice	2.64	0.22	1.00	0.19	25375	10987
Fortified compost	2.37	0.22	0.92	0.13	18895	13651
Mineral fertilizer	2.72	0.24	1.10	0.15	24584	13238
PREP package	2.78	0.24	1.20	0.08	26185	13336
MBILI package	2.43	0.26	1.26	0.24	20811	25378
Crotalaria fallow ^a	2.06	0.21	n.c.	0.16	14515	9258
Lablab relay	2.03	n.c.	0.88	0.14	15412	10388
LSD (0.05) (a)	0.27	0.04	0.27	0.04	551	4150

^a Crotalaria fallow management was intended to produce next residual benefits.

(a) LSD allows for yield comparison between management and season.

n.c. Shows no yield from the management as no cropping for the component was made in the season in question.

Maize, beans and groundnut were planted in the first rains 2002 and the same legumes replanted in the second season 2002. Lablab and crotalaria were also planted about mid way in the first season. Details of experimentation and the low carbon, nitrogen and phosphorus status of soils from 140 test farms are described elsewhere (Woomeer et al. 2003b). The soil test data for farms at preplanting are given in Table 15 (means for each district). However, being on-farm trials, some failure (23%) in recovery of yield data was met. Thus yield data for crops were obtained in 107 farms (Table 16). The overall performance of the intercropping management showed better performance from four technologies out-yielding the no inputs management. The PREP-PAC produced the highest yields (t/ha/year) and the MBILI package produced the greatest annual net return (ksh./ha/year). This positive effect of MBILI economically is largely due to maize-groundnut intercrop. Groundnut is usually sold for twice the price of beans in most areas of Kenya. Nonetheless, the MBILI management has reduced shading of legumes and an overall yield advantage over conventional intercropping (Woomeer et al. 2003b).

Phosphorus use efficiencies by maize from Best-Bets comparison above

Nutrient use efficiency (NUE) by crops is one of the well-known parameters used to evaluate the effectiveness of soil fertility management options. NUE is defined as:

Table 17. Phosphorus use efficiency (kg grain/ kg P uptake) in maize grain from soil fertility management options, combined over five districts in western Kenya, first rains 2002.

District	Technology (treatment)					Mean
	Compost	Farmers' practice	FURP	MBILI	PREP-PAC	
Bungoma	142	116	154	129	226	153
Homa Bay	-168	66	-131	-306	-76	-123
Siaya	235	325	281	323	-17	229
Teso	63	43	177	-264	132	30
Trans Nzoia	67	-46	54	-139	21	-9
Mean	68	101	107	-52	57	56
SED district	66.7					
SED treatment	84.1					
SED dist × trt	157.8					
P dist.	0.123					
P trt.	0.001					
P dist. × trt.	0.206					

Source: Data of K. W. Ndungu and M. N. Kifuko, Best Bets Project Collaborators (unpublished).

NUE =

$$\frac{\text{Change in crop yield above control yield}}{\text{Nutrient uptake by the crop from a nutrient applied}}$$

Thus in the technology comparison for soil fertility management options described above, both N and P inputs varied widely with technologies and therefore the NUEs for these two nutrients are expected to vary. Table 17 presents the P use efficiency data for selected five technologies and districts across western Kenya, focussing the maize grain component (most of the P is accumulated in the grain).

The P use efficiencies varied significantly with soil fertility options across districts, implying differences in maize P uptake from technologies with different P inputs and sites. Negative P use efficiencies are explained in terms of insignificant maize grain yield increases in some districts or soils, like the Homa Bay and Trans Nzoia districts. Homa Bay is particularly associated with rather adequate available P values (Table 15).

Conclusions and recommendations

- Food insecurity in sub-Saharan Africa is mainly explained in terms of low and declining crop yields. But soil fertility depletion particularly contributes to low and unsustainable crop yields.
- There is strong evidence that yields can be raised through applications of external nutrient inputs, but specifically the N and P inputs added indi-

vidually or in combinations. However, in the ASALs, soil moisture stress will limit the uptake of nutrients, implying the need to conserve water and soil organic matter as the top priority.

- Phosphate rocks of varying origins, reactivities and agronomic effectiveness are found widely in Africa. Efficient use of these materials needs to be revisited as it reflects a saving on costs associated with importation of refined mineral phosphate fertilizers.
- Towards the adoption process, soil fertility replenishment options should be evaluated side-by-side (or simultaneously) at on-farm level so that the end users and all stakeholders may have an opportunity to give their own assessment and rating of technologies in relation to effectiveness and economic-based information. Preliminary results from this approach in western Kenya need syntheses after experimentation in 2006.
- Extension messages need updating frequently to educate the farmer, particularly on the newly introduced technologies. To this end, short and simple messages in form of brochures are important, as well as other dissemination media.

Acknowledgements

The authors acknowledge the financial support given to them mainly by Kenya Agricultural Research Institute (KARI), Australian Centre for International Agricultural Research (ACIAR) and

the Rockefeller Foundation. They are grateful to the Tropical Soil Biology and Fertility (TSBF), Institute of CIAT for invitation to present this paper and their kind funding to attend this symposium. Finally, we wish to thank the Vice Chancellor, Moi University, Eldoret, Kenya for permitting time for the senior author to attend the symposium.

References

- Allan A.Y., Were A. and Laycock D. 1972. Trials of types of fertilizer and time of nitrogen application. In: Kenya Department of Agriculture, NARS Kitale. Ann. Rpt. Part II: 90–94.
- Amoding A., Muzira R., Bekunda M.A. and Woomer P.L. 1999. Bioproductivity and decomposition of water hyacinth in Uganda. *African Crop Sci. J.* 7(4): 433–439.
- Anderson G.D. 1970. Fertility studies on sandy loam in semi-arid Tanzania II. Effects of P, K and lime on yields of groundnuts. *Exp. Agri.* 6: 213–222.
- Ayaga G.O. 2003. Maize yield trends in Kenya in the last 20 years. A keynote paper. In: Othieno C.O., Odindo A.O. and Auma E.O. (eds.), *Proceedings of a Workshop on Declining Maize trends in Trans Nzoia district*, Moi University, May 2003, pp. 7–13.
- Bationo A. (ed) 2004. *Managing Nutrient Cycles to sustain Soil Fertility in sub-Saharan Africa*. TSBF–CIAT–AfNet. Academy Science Publishers, Nairobi, pp. 608.
- Birch H.F. 1952. The relationship between phosphorus response and base saturation in acid soils. *J. Agric. Sci.* 42: 276–285.
- Buresh R.J., Smithson P.C. and Hellums D.T. 1997. Building soil P capital in sub-Saharan Africa. In: Buresh R.J., Sanchez P.A. and Calhoun F. (eds), *Replenishing Soil Fertility in Africa*. SSSA Special Publication No. 51, SSSA, Madison, Wisconsin, USA, pp.111–149
- Butters B. 1961. Correlation between pot tests and analytical data: data for the major elements in Uganda soils. *Proceedings of the East African Senior Chemists Conference* 1961.
- Cooke G.W. 1967. *Control of Soil Fertility*, The ELBS and Cosby Lockwood and Sons Ltd., UK
- Evans A.C. 1963. Soil Fertility studies in Tanganyika. III. On the Kikungu and Luseni soil types of the Lake and Western regions. *E. Afr. Agric. For. J.* 28: 231–239.
- Foster H.L. 1973. Fertilizer recommendations for cereals grown on soils derived from volcanic rocks in Uganda. *E. Afr. Agric. For. J.* 38: 303–313.
- FURP (Fertilizer Use Recommendation Project). 1994. *Fertilizer Use Recommendations Vols. 1–22*. Kenya Agricultural Research Institute (KARI), Ministry of Agriculture, Nairobi, Kenya.
- Gachene C.K.K. and Kimaru G. 2003. The crisis in land and agricultural productivity. In: *Soil Fertility and Land Productivity: A Guide for Extension Workers in the Eastern African Region*, Ch.1, p. 1–7, Technical Handbook no. 30, RELMA.
- Gachengo C.N., Palm C.A., Jama B. and Othieno C.O. 1999. Tithonia and senna green manures and inorganic fertilizers as phosphorus sources for maize in western Kenya. *Agroforest. Sys.* 44: 21–26.
- Gachengo C.N., Vanlauwe B., Palm C.A. and Cadisch G. 2004. Chemical characterization of a standard set of organic materials. In: Delve R.J. and Probert M.E. (eds), *Modeling Nutrient Management in Tropical Cropping Systems*. ACIAR Proceedings No. 114, pp. 48–53.
- Gathecha T.W. 1970. The maintenance and improvement of soil fertility under arable crops and grass leys in the first and second rotation cycles of a fertilizer at Embu. *E. Afr. Agric. For. J.* 35: 246–253.
- Gichuru M.P., Niyungeko J., Adiko A., Koffi N., Kotto-Same K.N., Mobambo A., Moikam B.A., Ritigira and Tano Y. 2003. Soil Fertility Management in Africa: A Regional Perspective, Ch. 5. In: M. P. Gichuru et al. (eds), *DANIDA, TSBF-CIAT, CTA*, pp. 306.
- Gopal B. 1987. *Water Hyacinth*. Elsevier Science Publishers, Amsterdam, The Netherlands.
- Greenland D. 1974. Evaluation and development of different types of shifting cultivation. *FAO Soils Bull.* 24: 5–13.
- Haides S.Z., Malki K.M.A., Rahman M.N. and Ali M.A. 1984. Water hyacinth compost as a cheap fertilizer. In: Thygarajan G. (ed), *Proceedings of the International Conference on Water hyacinth*. UNEP, Nairobi, Kenya, p.751–758.
- Ikombo B.M., Esilaba A.O., Kilewe A.M. and Okalebo J.R. 1994. Soils and Water Management Practices in Smallholder Farms in Kiambu District, Kenya. A diagnostic survey. *Proceedings of the 4th KARI Annual Scientific Conference*, Nairobi, October 1994, pp. 30.
- Jama B., Swinkels R.A. and Buresh R.J. 1997. Agronomic and economic evaluation of organic and inorganic sources of phosphorus in Western Kenya. *Agron. J.* 89: 597–604.
- Kariuki (Rev.) N. 2003. Non-Governmental Organizations (NGOs) views of declining maize yields in Trans Nzoia district, Kenya. (In: C.O. Othieno, A.O. Odindo and E.O. Auma, *Proceedings of a Workshop on: Declining Maize Trends in Trans Nzoia district*, Kenya, pp. 20–22, May 2003, pp. 69).
- Keating B.A., Wafula B.M. and Watiki J.M. 1992. Exploring strategies for increased productivity – the case for maize in semi-arid eastern Kenya. In: Probert M.E. (ed), *A Search for Strategies for Sustainable Dry Land Cropping in Semi-arid Eastern Kenya*. ACIAR, (Australia) Proceedings No. 41, pp. 90–100.
- Kifuko M.N., Othieno C.O., Okalebo J.R., Kimenye L.N., Ndungu K.W. and Kipkoech A.K. 2003. Agronomic and economic evaluation of residual Minjingu phosphate rock in combination with organic residues on maize yield in Busia, Western Kenya. *Proceedings of the 6th Biennial Conference of the African Crop Science Society*, Nairobi, Kenya, circulated in a CD ROM in 2005 in Entebbe, Uganda.
- Lwayo M.K., Okalebo J.R., Muasya R.M. and Mongare P.O. 2001. A diagnostic survey on the production constraints and utilization of phosphate fortified wheat straw and maize stover compost for increasing cereal production in Uasin Gishu district, Kenya. A report, pp.108.
- Marandu W.Y.F., Uriyo A.P. and Mongi H.O. 1973. Residual effects of NPK fertilizer application on the yield of maize and

- pasture on a ferralsol at Morogoro, Tanzania. *E. Afr. Agric. For. J.* 40: 400–407.
- Mkangwe C.Z. 2003. Effects of Minjingu Phosphate rock and triplesuperphosphate as phosphorus sources for maize and groundnut in semi-arid lands of central Tanzania. *E. Afr. Agric. For. J.* 69(1): 81–88 (Special issue).
- Mongi H.O., Chowdhury M.A. and Semoka J.M.R. 1974. Lime, nitrogen and phosphorus effects of inorganic N and yield of upland rice in an oxisol. Proceedings of the 5th Eastern African Cereals Research Conference, Lilongwe, Malawi, March 1974. pp.1–18.
- Muasya R.M. 1996. Wheat response to fortified wheat straw compost. M. Phil Thesis, Moi University, Eldoret, Kenya.
- Mugendi D., Mucheru M., Kungu J., Otor S., Micheni A. and Mugwe J. 2001. Soil fertility improvement strategies for increased food production in the central highlands of Kenya. *African Crop Sci. Confer. Proc.* 5: 897–904.
- Muriithi F.M., Thijssen H.J.C., Mugendi D.N., Mwangi J.N., O'Neill M.K. and Nyaata O.Z. 1994. Report of a survey on agroforestry technologies used for fodder production and soil fertility improvement in Meru district, Kenya. National Agroforestry Research Project, RRC, Embu, Kenya.
- Mutuo P.K., Mukalama J.P. and Agunda J. 1998. On-farm testing of organic and inorganic phosphorus sources on maize in western Kenya. In: *The Biology and Fertility of Tropical Soils*. TSBF Report, pp. 22.
- Mwaura F.M. 2002. The market testing of PREP-PAC: A new technology in soil fertility management for resource poor smallholder farmers in western Kenya. M. Phil thesis, Moi University, Eldoret, Kenya.
- Ndungu K.W., Okalebo J.R., Othieno C.O., Kimenye L.N., Kifuko M.N. and Okeyo M.M. 2003. Effect of residual Minjingu phosphate rock on continuous production of maize in nutrient depleted soils of Western Kenya. Proceedings of the 6th Biennial Conference of the African Crop Science Society, Nairobi, Kenya, circulated in a CD ROM in 2005 in Entebbe, Uganda.
- Nekesa P., Maritim H.K., Okalebo J.R. and Woomer P.L. 1999. Economic analysis of maize-bean production using a soil fertility replenishment product (PREP-PAC) in western Kenya. *African Crop Sci.* 7(4): 423–432.
- Ngatunga E.L. and Deckers J. 1964. Preliminary results of a long term experiment comparing the effects of PR and TSP on the yield of maize and sorghum at Mukendele, Mtwara, Tanzania. In: Proceedings of the 6th Ann. Gen. Meeting of the Soil Science Society of East Africa, pp. 26–37, Arusha, Tanzania.
- Nyambati R.O. 2000. Soil phosphorus fractions as influenced by phosphorus and nitrogen sources on two sites in western Kenya. M. Phil Thesis, Moi University, Eldoret, Kenya.
- Obura P.A., Okalebo J.R. and Woomer P.L. 1999. An integrated soil fertility amelioration product intended for smallhold farmers in western Kenya. In: J. Y. K. Zake, J. K. Tumuhairwe, C. Nkwiine and S. Sessanga (eds.) Proceedings of the 17th Conference of the Soil Science Society of East Africa, Kampala, Uganda.
- Obura P.A. 2001. The effect of phosphate rock and rhizobium inoculation on growth, yield and nutrient uptake of maize-soybean intercrop in acid soils of western Kenya. M. Phil Thesis, Moi University, Eldoret, Kenya.
- Okalebo J.R. 1987. A study of the effect of phosphorus fertilizers on maize and sorghum production in some East African soils. Ph.D. Thesis, University of Nairobi, Kenya.
- Okalebo J.R. and Woomer P.L. 1994. Use of rock and fertilizer phosphorus in eastern and southern Africa. A data summary. Proceedings of the 4th Conference of the Soil Science Society of East Africa, Mbarara, Uganda.
- Okalebo J.R., Simpson J.R. and Probert M.E. 1992. Phosphorus status of cropland soils in the semi-arid areas of Machakos and Kitui districts, Kenya. In: Probert M.E. (ed), A search for strategies for sustainable dry land cropping in semi-arid eastern Kenya. ACIAR, (Australia) Proceedings No. 41, pp. 50–54.
- Okalebo J.R., Palm C.A., Gichuru M., Owuor J.O., Othieno C.O., Munyampundu A., Muasya R.M. and Woomer P.L. 1999. Use of wheat straw, soybean trash and nitrogen fertilizer for maize production in the Kenya highlands. *African Crop Sci. J.* 7: 423–432.
- Palm C.A., Gachengo C.N., Delve R.J., Cadisch G. and Giller K.E. 2001. Organic inputs for soil fertility management in tropical agroecosystems: application of an organic resource database. *Agri. Ecosys. Environ.* 83: 27–42.
- Pinkerton A. 1958. Bioassays – pot tests. Proceedings of the East African Specialist Committee Meeting on Soil Fertility.
- Probert M.E. and Okalebo J.R. 1992. Effects of phosphorus on the growth and development of maize. In: Probert M.E. (ed), *Semi-Arid Eastern Kenya*. ACIAR, (Australia) Proceedings No. 41, pp. 55–62.
- Probert M.E., Okalebo J.R., Simpson J.R. and Jones R.K. 1992. The role of boma manure for improving soil fertility. In: Probert M.E. (ed), *Sustainable Dry land Cropping Symposium*. ACIAR, (Australia) Proceedings No. 41, pp. 63–70.
- Probert M.E., Delve R.J., Kimani S.K. and Dimes J.P. 2004. The APSIM Manure Module: Improvements in predictability and application to Laboratory studies. In: Delve R.J. and Probert M.E. (eds), *Modeling Nutrient Management in Tropical Cropping Systems*. ACIAR, Australia Proceedings No. 114, pp. 76–84.
- Sanchez P.A., Shepherd K.D., Soule M.J., Place F.M., Mkwunye A.U., Buresh R.J., Kwasiga F.R., Izac A.-M.N., Ndiritu C.G. and Woomer P.L. 1997. Soil Fertility Replenishment in Africa: An investment in natural resource capital, pp. 1–46. In: Buresh R.J., Sanchez P.A. and Calhoun F. (eds), *Replenishing Soil Fertility in Africa*. SSSA Special Publication No. 51, Madison, Wisconsin, USA.
- Schumaker G. and Ogolle S. 1967. Sorghum and finger millet fertilizer trials in Serere, Uganda. In: *EAAFRO Record of Research Ann. Rpt.* 1967.
- Semoka J.M.R. and Kalumuna M. 1999. Potentials and constraints of using rock phosphate for crop production in Tanzania. Soil Science Department, SUA. Morogoro, Tanzania. Technical Report to FAO, November 1999 (unpublished, pp. 26).
- Shepherd K.D., Ohlson E., Okalebo J.R. and Ndufa J.K. 1996. Potential impact of agroforestry on soil nutrient balances at farm scale in the East African Highlands. *Fert. Res.* 44: 87–89.
- Smaling E.M.A., Nandwa S.M. and Janssen B.H. 1997. Soil fertility in Africa is at stake. In: Buresh R.J. (eds), *Replenishing Soil Fertility in Africa* SSSA Special Publication No. 51, Madison, Wisconsin, USA.

- Starks K.J., Schumaker G. and Eberhart S.S. 1971. Soil fertility and damage of *Chilo zonallus* to grain sorghum. *J. Econ. Entomol.* 64: 740–743.
- Stephens D. 1961. A preliminary note summarizing results of field experiments and pot tests relevant to the phosphate status of Uganda soils. Proceedings of the Conference of Senior Chemists, EAAFRO, Kenya.
- Stephens D. 1967. The effects of ammonium sulphate and other fertilizers and inoculation treatments on beans. *E. Afr. Agric. For. J.* 32: 411–417.
- Swinkels R.A., Franzel S., Shepherd K.D., Ohlsoon E. and Ndufa J.K. 1997. The economics of short term rotation improved fallows: Evidence from areas of high population density in western Kenya. *Agri. Syst.* 55: 99–121.
- SBF (Tropical Soil Biology and Fertility) 1994. Limiting nutrient experiments conducted in Kabras Division, Kakamega District, Ann. Rpt. 1994.
- Uriyo A.P., Singh B.R. and Kimambo A.E. 1976. Fertilizer use technology for growing maize on oxisol at Morogoro. I. Phosphorus placement. III: N P effects on soil, NPK in leaves and grain yield of variety Ilonga Composite. Proceedings of the Sixth Eastern African Cereals Research Conference, Morogoro, Tanzania.
- Vadlamudi V.R. and Thimm H.U. 1974. Economic analysis of fertilizer trials conducted in Kenya on maize. *E. Afr. Agric. For. J.* 40: 189–201.
- Van Kauwenburgh S.J. 1991. Overview of Phosphate Deposits in East and South Africa. *Fert. Res.* 30: 127–150 (Special issue).
- Wokabi S.M. 1994. Quantified land evaluation for maize yield gap analysis at three sites in the Eastern slopes of Mt. Kenya. International Institute for Aerospace Survey and Earth Science (ITC), The Netherlands.
- Woomer P.L. and Muchena F.N. 1996. Recognizing and overcoming soil constraints to crop production in tropical Africa. *African Crop Sci. J.* 4: 503–518.
- Woomer P.L., Karanja N.K. and Okalebo J.R. 1999a. Opportunities for improving integrated nutrient management by smallhold farmers in the Central Highlands of Kenya. *African Crop Sci. J.* 7(4): 441–454.
- Woomer P.L., Bekunda M.A. and Nkalubo S.T. 1999b. Estimation of banana yield based on bunch phenology. *African Crop Sci. J.* 7(4): 341–347.
- Woomer P.L., Okalebo J.R., Maritim H.K., Obura P.A., Mwarura F.M., Nekesa P. and Mukhwana E.J. 2003a. PREP-PAC: A nutrient replenishment product designed for smallholders in western Kenya. *Agri. Ecosys. Environ.* 100: 295–303.
- Woomer P.L., Musyoka M.W. and Mukhwana E.J. 2003b. Best Bet Maize – Legume Intercropping Technologies and Summary of 2002 Network Findings. Best bet Bulletin, SACRED Africa, Bungoma, Kenya. pp. 18.

Integrated Agricultural Research for Development: contributing to the Comprehensive Africa Agricultural Development Programme (IAR4D in CAADP)

Ralph von Kaufmann

Senior Resource Person, FARA PMB CT 173, Accra, Ghana <r.vonkaufmann@fara-africa.org>

Abstract

Agricultural research in Africa has had numerous remarkable successes but the sector has continued to perform badly. This has contributed to falling incomes, increasing food insecurity and continuing degradation of land and water resources. To realise the potential of agriculture to contribute to achieving the Millennium Development Goal (MDG) NEPAD has developed the Comprehensive Africa Agriculture Development Programme (CAADP). Two major projects are being developed to support CAADP by promoting new concepts for the conduct of agricultural research in Africa and providing the required resources. The Multi Country Agricultural Productivity Programme (MAPP) is intended to underpin CAADP's agenda for reform of agricultural research by providing incentives and means for enhancing the efficiency of agricultural technology generation, transfer and adoption. Its goal is to double annual spending on agricultural technology generation and dissemination in Africa by 2015 from about US\$2.3 billion currently to about US\$4.5 billion.

The Sub Saharan Africa Challenge Programme (SSA CP) will promote Integrated Agricultural Research for Development (IAR4D). This new approach builds on Integrated Soil Fertility Management (ISFM) and Integrated Natural Resource Management (INRM) with research on increased productivity and sustainable natural resource management being integrated with research on policies and markets with an emphasis on the interactions between these four factors.

The IAR4D approach recognises that, in addition to disciplinary and basic research skills, agricultural scientists and trainers need the ability to put their disciplines into dynamic systems contexts and to integrate the contributions of different disciplines. They also need to be able to develop partnerships and manage change with multiple stakeholders in the agricultural sector and wider society. This will require building and managing interdisciplinary and inter-institutional teams and enabling all stakeholders to participate.

The research will be underwritten by facilitation, information and knowledge management and capacity building to ensure that the approaches of IAR4D will be internalised, implemented, and scaled out and up to have national and continental level impact on improving the livelihoods of African smallholders and pastoralists.

Key words: Africa, integrated, participatory, agricultural research for development

Background

Agricultural research has had numerous significant successes in Africa (Alston et al. 2000 and Pardey et al. 1997). Without new varieties, maize production would be 25% less than it is today. New cassava cultivars have 40% higher yields and without fertilizer have raised

continental per capita output by 10% benefiting 14 million farmers (Nweke et al. 2002). Anderson (2003) has provided evidence of communally managed success in natural resource management in countries across the continent such as Botswana, Namibia, Madagascar and Mali. The NEW RICE for Africa (NERICA) rice varieties are saving West African countries millions of

dollars by reducing food imports. Research in Africa that led to the development of the rinderpest vaccine and biological control of the cassava mealie bug have both earned the World Food prize in recognition of the impact they have had on the lives of millions of Africans. (Since this paper was presented Dr. Monty Jones has been awarded the World Food Prize for his work on NERICA Rice.)

However, despite the successes, 50% more Africans have fallen into poverty in the last 14 years (Amoako 2003). Sub-Saharan Africa now has 38 of the 48 least developed countries with 16% of the people living in countries with GNP per capita of less than \$200/pa, the lowest average per capita income in the world. There are 180 million people in sub-Saharan Africa living on less than US\$1 per day and this is expected to reach over 300 million by 2020 (Amoako 2003).

A major cause of Africa's increasing poverty is the poor performance of its agricultural sector which, in the last 30 years, has been the worst in the developing world. This has resulted in 385 million smallholders (61%) producing the lowest yields in the world, which has resulted in falling incomes and increasing food insecurity (NEPAD 2003). A situation threatening to get worse because of degrading land, water, wetland and rangeland resources and a dearth of alternative ameliorative technologies. Even where there are technologies that have the potential to improve yields and natural resource management research has fallen short of overcoming the obstacles to high adoption rates.

The millennium development goals

Recognising that a more concrete and focused approach is needed to address the problems of underdevelopment, the international community endorsed the Millennium Development Goals (MDGs). This commits nations to "an expanded vision of development, one that vigorously promotes human development as the key to sustaining social and economic progress in all countries, and recognizes the importance of creating a global partnership for development. The goals have been commonly accepted as a framework for measuring development progress".

Although agricultural development contributes to the achievement of every MDG, those with immediate relevance are MDGs 1, 3, 7 and 8.

MDG 1: Eradicate extreme poverty and hunger.

The targets of this MDG are, between 1990 and

2015, to halve the proportion of people whose incomes are less than \$1 a day and who suffer from hunger. This is a hugely ambitious target given that the trends are, in 2004, still in the opposite direction. Fourteen years have passed and there are only 11 to go to 2015. However, aiming for anything less would be unacceptable for humanitarian and political reasons. Major changes must be made in the way that agricultural development is promoted and funded to ensure that these targets are achieved.

MDG 3: Promote gender equality and empower women. The target of the MDG is to eliminate gender disparity in primary and secondary education preferably by 2005 and in all levels of education no later than 2015. However, it is probably more important that African women should get a fair deal in agriculture so that they can have equal access to material and intellectual resources and can participate in decisions in ways that reflect the fact that the majority of African farmers are women.

MDG 7: Ensure environmental sustainability. The targets of this MDG are to integrate the principles of sustainable development into country policies and programmes and to reverse the loss of environmental resources. It aims to halve, by 2015, the proportion of people without sustainable access to safe drinking water and basic sanitation and, by 2020, to have significantly improved the lives of at least 100 million slum dwellers. Since agriculture has the greatest anthropological impact on the world's natural resources it is curious that improved farming and pastoral practices are not directly referred to as targets. However, it will be impossible to achieve the targets without improvements in agriculture. For example, with food being the major expense of slum dwellers, reducing the cost of food would bring the most significant improvement in their lives.

MDG 8: Develop a global partnership for development. The targets of this MDG are to address the special needs of the least developed countries (including tariff-and quota-free access for exports enhanced program of debt relief for heavily indebted poor countries (HIPC) and cancellation of official bilateral debt, and more generous ODA for countries committed to poverty reduction), to address the special needs of landlocked countries and small-island developing states and, to deal comprehensively with the debt problems

of developing countries through national and international measures in order to make debt sustainable in the long term. These targets have extremely important implications for agriculture. The comparative advantages of developing countries are being annulled by export subsidies and import tariffs imposed by developed countries. Whereas arrangements such as the Lome Convention and its successors provide access to developed markets of unprocessed products, many of which cannot be produced in temperate countries, attempts by developing countries to generate employment and add value by, for example turning cocoa into chocolate, roasting and grinding coffee, fashioning hides into leather goods, are impeded by high Organisation for Economic Cooperation and Development (OECD) country import tariffs.

NEPAD – origins and agricultural priorities

The New partnership for Africa's Development (NEPAD) is an expression of the determination of African leaders to get their countries out of poverty and progressing towards sustainable development and full participation in the global economy. It articulates their conviction that this will only happen if it is led by Africans themselves. They believe that there are sufficient capital, technical and human resources "to launch a global war on poverty and underdevelopment". But these resources have to be mobilized and used properly and NEPAD gives high priority to agricultural development. It has set out the requirements for this in its Comprehensive Africa Agricultural Development Programme (CAADP) (NEPAD 2003).

CAADP – concepts and content

CAADP was endorsed by African Ministers of Agriculture in June 2002 as a guide for action to revitalise African agriculture and it was agreed that it should be quickly translated into action. In the continually changing internal and external circumstance of African agriculture CAADP will have to continue to evolve as a major component of African national and regional poverty reduction strategies (PRSPs), which set out the priorities that the countries themselves and their development partners will focus on. CAADP has four primary areas for action:

1. Extending the area under sustainable land management and reliable water control systems
2. Improving rural infrastructure and trade-related capacities for market access
3. Increasing food supply and reducing hunger
4. Agricultural research, technology dissemination and adoption

These priorities were selected for their potential to make the quickest impact in addressing Africa's agricultural crisis.

The first action point; *Extending the area under sustainable land management and reliable water control systems* is a response to lack of land for further expansion of agricultural production, calling for yield increases. In addition to the need to improve water management, this action point also responds to the fact that 16 percent of all African soils are classified as having low nutrient reserves (NEPAD 2003). For comparison, in Asia the equivalent figure is only four percent. Building up soil fertility and the moisture holding capacity of agricultural soils, will, *inter alia*, enable farmers to raise output on a sustainable basis and contribute to the reliability of food supplies".

The second action area; *Improving rural infrastructure and trade-related capacities for market access* recognises that the value of increased yields cannot be realised unless the products can be stored, transported and processed for markets. Good infrastructure is required to enable local production to compete effectively against imports but this is typically lacking creating a major constraint on African agriculture. There are also increasingly stringent quality control impositions in local as well as export markets.

The third action area; *Increasing food supply and reducing hunger* addresses the need for improved technologies and support systems, including enabling policies, which are adapted to the needs of rural communities and smallholders. The ongoing crises demand the provision of food for disaster and emergency relief but this must be followed up by long-term development. Likewise production related investments must be underwritten with targeted safety nets that will ensure continuing progress over the long-term, despite recurrent set backs due, for example, to adverse weather cycles.

The fourth action area: *Agricultural research, technology dissemination and adoption* is intended to provide the scientific underpinning for long-term productivity gains and competitiveness. CAADP recognises that this will require:

1. Enhanced rates of adoption of the most promising available technologies through more efficient linkages between research and extension systems and producers so as to support immediate improvements in African production;
2. Technology delivery systems that quickly bring innovations to farmers and agribusinesses thereby making increased adoption possible, notably through appropriate use of new information and communication technologies;
3. Renewing the ability of agricultural research systems to efficiently and effectively generate and adapt new knowledge and technologies, including biotechnology, needed to increase output and productivity while conserving the environment; and
4. Mechanisms that reduce the costs and risks of adopting new technologies.

It is estimated that this will require a total investment of US\$4.6 billion between 2002 and 2015 and the goal is to double the current annual spending on agricultural research in Africa within ten years. Achieving this will require increasing the total investment in research and technology development. This will require increasing the share of private sector funding of agricultural research accompanied by institutional and financial reforms aimed at making national agricultural research systems more sustainable.

Programmes for implementing CAADP

Turning CAADP into action will require new concepts and new money in order to improve the livelihoods of the majority of Africans. A first requirement for change is to remove the myth that there is a lot of technology on the shelf that only requires to be implemented. Many good technologies have been adopted often in spite of weak extension systems or even in the face of official opposition when thought to be unsuitable. This indicates that there is something wrong with those that have not been taken up. The myth that there are shelves full of good technologies waiting to be adopted stems from

the pipeline approach to technology generation. In this approach research institutions developed innovations that were then supposed to be taken on by the extension services whose duty was to convince the farmers to adopt them. Thus the lack of adoption of technologies that had apparently worked under research conditions was assumed to be due to failure in extension and left at that. With advances in understanding of systems of innovation and the need for all stakeholders to be involved in all stages of research and development the faults and needs for redesign of technologies that fail to be adopted are being exposed.

The first efforts at operationalising CAADP will be focused on key opportunities that can yield largest gains and benefit as many of Africa's poor and hungry as possible. They will interpret CAADP's pillars into specific priorities for Africa's diverse national, sub-regional and continental realities by addressing four critical needs:

1. Creating a basis for informed choice of investment priorities
2. Formulating and funding of additional concrete projects
3. Integrating NEPAD programmes into development budgets
4. Action to promote private sector engagement and interest

MAPP supporting structural change and greater investment in agricultural research

CAADP's agricultural research programme is comprised of four sub themes which will collectively contribute to testing the central hypothesis: "*that conservation and efficiency of use of soil and other natural resources will be optimised under conditions of market and/or policy and institution driven productivity*"

The four research themes are:

1. Integrated Natural Resource Management
2. Adaptive management of appropriate germplasm
3. Development of sustainable market chains
4. Policies for sustainable agriculture

CAADP recognises that scientific capacity building is required across all these four themes.

The Multi-country Agricultural Productivity Programme (MAPP) is being developed to provide the concepts and resources for reinvigorating and restructuring African national agricultural research systems. MAPP responds to the demands for structural change and

greater investment in agricultural research by providing support for:

- the reform agenda for agricultural research outlined in Chapter 5 of CAADP
- the vision for African agricultural research developed by FARA
- the actions in the five key thematic areas of the United Nations water environment, health, agriculture, biodiversity (UN WEHAB) Initiative

MAPP is also framed by the action plan on Africa of the World Summit for Sustainable Development (WSSD). It also is intended to provide the means for achieving unrestricted access to expanding international markets and the ability to take advantage of Agricultural Trade Liberalization. It will seek technologies for improving the management of natural resources where traditional methods for restoring soil fertility and vegetative cover are undermined by growing land scarcity. It will support the development and application of new research methodologies, increased investments in human capital, development of institutions such as farmers' organisations and building new partnerships with processors and agro-industry.

MAPP will facilitate Africa's participation in the agricultural revolution by enabling increased investment in technology generation and dissemination, which will lead to technological change that will support sustained and wide-spread agricultural growth and result in increased competitiveness and profitability of African agriculture. It will provide funding for investments in and improve the efficiency of agricultural technology generation, transfer and adoption. This will be achieved by adopting five principles for building strong NARS:

1. Increasing stakeholder input in agricultural research
2. Improving funding and financial sustainability
3. Increasing transparency and accountability
4. Strengthening linkages between research, extension and end-users
5. Increasing collaborations

MAPP has an extensive and holistic research agenda including the following:

Land frontier

1. Finding alternatives to area expansion that has been the traditional source of increased agricultural production

2. Considering farmers living in low potential areas and encouraging low use of external inputs and resource base conservation

Reducing risk

3. Mitigating the vulnerability of African rural people exceptionally exposed to adverse shocks, such as droughts, pests and diseases
4. Finding strategies for mitigating and coping with risk including diversification of income sources and social networks
5. Addressing the needs of the poorest, especially women who have constraints on time, access to technological information and investment capital and gaining them much greater voice in priority setting and the development and implementation of technology generation

Improved sil and water management

6. Addressing the most critical issue of water management in rain-fed farming systems usually characterized by soil degradation and nutrient depletion
7. Finding better low-cost agronomic practices for resource-poor farmers
8. Determining the investments in infrastructure and the policy and trade reforms that reduce the cost and raise the efficiency of external inputs

Increased productivity

9. Providing a combination of genetics and yield-improvement technologies and improved management practices

MAPP will specifically address *Technology Transfer and Adoption System* where African governments have to shift away from the traditional pipeline approach of transferring prescriptive information to that of enhancing farmers' technical skills and understanding and promoting pluralistic, demand-driven agricultural advisory systems that give greater control and choice to the farmers. MAPP will also focus on *Improving the Efficiency of Agricultural Technology Development Systems* where it will promote refocused agricultural research that generates technologies fitted to Africa's complex small-holder farming systems, which are for example much

more complex than the uniform Asian irrigated rice systems in which the Green Revolution packages were readily applicable. This will be supported by institutional reforms to improve accountability, efficiency and sustainability and sustainable funding mechanisms.

MAPP proposes innovative funding mechanisms that while encompassing all players will enable the end users or the institutions nearest to them to control the

allocation of resources to ensure that the research is demand-led and participatory. The institutions that will be eligible for funding, the use to which they will be able to put the funds and the proposed source of the funds is shown in Table 1.

The success of CAADP depends on continuing commitment to it by all agricultural authorities from the level of the Commission of the African Union, NEPAD, the Regional Economic

Table 1. The disposition of MAPP funding.

Institution	Use of funds	Source of funds
NEPAD	<ul style="list-style-type: none"> • Overall governance 	<ul style="list-style-type: none"> • Government's contributions
International Centers of Excellence	<ul style="list-style-type: none"> • Own activities • Research programs contracted by FARA/SROs; • Training and capacity building programs in favor of NARSs 	<ul style="list-style-type: none"> • International community • FARA/SROs • NARSs
FARA	<ul style="list-style-type: none"> • Own management Funding of contracted • Africa-wide CGIARs programs; • Funding of SROs management • Funding of SROs agreed upon annual research and capacity-building work programs 	<ul style="list-style-type: none"> • International community • Governments' contributions
SROs	<ul style="list-style-type: none"> • Own activities/management • Funding of sub-regional programs contracted to ICs • Funding of sub-regional research programs through competitive mechanism • Co-funding of agreed upon capacity-building programs for NARSs 	<ul style="list-style-type: none"> • International community and/or FARA • NARSs contributions
National Research Institutions	<ul style="list-style-type: none"> • Own activities • Contribution to SROs • Co-funding of regional research programs • Co-funding of own capacity-building programs 	<ul style="list-style-type: none"> • Governments/Donors • End-users
National Advisory Services	<ul style="list-style-type: none"> • Own activities • Co-funding of Farmers' Organisations and private sector capacity-building and pilot activities 	<ul style="list-style-type: none"> • Governments/donors • End-users
Farmers Organizations	<ul style="list-style-type: none"> • Own activities • Contribution to NARSs and advisory agencies 	<ul style="list-style-type: none"> • Members contribution • Matching grants from Government/public advisory agencies
Private Sector Operators	<ul style="list-style-type: none"> • Own management and activities; • Contribution to professional associations 	<ul style="list-style-type: none"> • Own funds • Matching grants from Government/public advisory agencies

Communities, national governments and national agricultural research and development institutions. Such unity of purpose has not been achieved before and it remains to be seen if Africa's resolve to lead its own development will be sufficiently strong and sustainable. However, there is no other feasible alternative at this time and it must be given every chance to succeed.

Sub-Saharan Africa Challenge Programme (SSA CP)

The constraints imposed by poor quality and degrading soil and water resources are consistently identified as the most widespread and pervasive constraints on African agriculture. The lack of investment in replenishing natural resources forebodes dire long-term consequences for African agriculture. Changing this will need more than just soil and water technologies. It will require what has been termed the four 'I's, i.e., incentives, inputs, information and institutions and these are not sufficiently evident in sub-Saharan African smallholder and pastoral systems.

The Sub-Saharan African Challenge Programme is being developed as a response to the above situation with the objective of adding value to and raising the impact of agricultural research in sub-Saharan Africa. It will be the first programme to take advantage of the existence of the continuum of African agricultural institutions in which National Agricultural Research Institutes (NARIs) are collaborating with each other to gain critical mass as National Agricultural Research Systems (NARS). These NARS have formed Sub-regional Agricultural Research Organisations (SROs) such as Strengthening Agricultural Research in Eastern and Central Africa (ASARECA), the Conseil Ouest et Centre Africain pour la Recherche et le Développement Agricoles (CORAF/WECARD) and the Southern African Development Community, Food, Agriculture and Natural Resources department (SADC/FANR) to address issues that are common between neighbouring countries and minimise duplications. The SROs have in turn formed the Forum for Agricultural Research in Africa (FARA) as an apex body to address continental issues in agricultural research.

The SSA CP Programme Formulation Workshop, Accra, March 2003 proposed Integrated Agricultural Research for Development (IAR4D) as an approach

that would raise the impact of African agricultural research by going further than Integrated Natural Resource Management (INRM) to encompass institutional capacity, market factors, knowledge management and policy issues. It would also pay attention to reversing gender biases and emphasise participatory methods, cross scale analysis and adaptive management.

The SSA CP recognises that producing high-impact innovations will require:

- Redefining the roles of scientists and farmers through collaborative learning processes
- Addressing level and timing and form of participation and how to foster it
- Including policies and marketing issues to encourage sustainable income enhancing innovations
- Understanding interactions between institutional innovation and technological innovation
- Self learning aided by facilitation as teams adopt and adapt to the 'new' research for development approach
- Capacity building for individuals linked to ways in which institutions are structured and managed

The greater impact sought by the Programme will come from focusing on three major innovative integrated thrusts:

1. the complexity and heterogeneity of farming systems
2. interactions between natural resource management, production systems, markets and policies
3. institutional changes to bring all stakeholders together

These will be supported by improvements in information and knowledge and capacity building.

The SSA CP's *Vision* is 'Improved rural livelihoods, increased food security and sustainable natural resource management throughout sub-Saharan Africa as a result of greater impact from agricultural research for development'. Its *Mission* is 'To add value and enhanced impact to ongoing agricultural research for development in sub-Saharan Africa by achieving greater coherence and efficiency through application of the principles and methods of IAR4D'.

SSA CP's *Goal* is to attain quantifiable improvement in alleviating rural poverty, agricultural productivity, sustainable natural resource management and the adaptive capacities of scientists, policy-makers and farmers within fifteen years.

Its *Objectives* are:

1. Productivity and profitability increased through intensified smallholder production, sustainable natural resource management, improved markets and enabling policies
2. Impact quantifiably increased by improved mechanisms for enhancing information management and facilitating the flow of knowledge between the generators and the users and incorporating measures for facilitating out- and up-scaling from the outset.
3. Change from focusing on narrow sectoral concerns to multi-institutional and multi-disciplinary research

The SSA CP's integrated research agenda has the following principal components:

1. Developing functional markets that will involve developing sustainable production of higher value niche commodities, adding value to products by processing and organising markets, organising critical market functions of assembly, grades, storage etc, institutional innovations to reduce market transaction costs and interlinking inputs and outputs through intervention points
2. Intensification of smallholder farming systems that will involve determining the optimum balance for sustainable intensification in subsistence-oriented production systems, between specialisation and

integration suited to markets for African farm products

3. Sustainable management of natural resources involving increasing investment in the management of soil, water and agro-biodiversity by smallholder farmers and pastoralists by adapting on-farm NRM to the fluctuations of market demand, managing natural resources across scales for multiple benefits from ecosystem services, and determining the private and social trade-offs and, adopting an integrated approach to reducing land degradation
4. Developing enabling policies that will focus on analysis of comparative advantages in export crops, promoting private/public partnerships, promoting export and intra-regional agricultural trade, favouring collective institutions (e.g., community-based organisations, co-operatives) and, ensuring that small-scale farmers, and women farmers in particular, have better access to services and assets

An important aspect of IAR4D is that research on the interactions between these factors is at least as important as research on the factors themselves (Figure 1). The integration will provide policy-makers with options from which pro-poor and gender-equitable policies can be formulated.

The IAR4D projects that will be supported by the SSA CP will be designed around entry points targeted at removing specific constraints and focusing

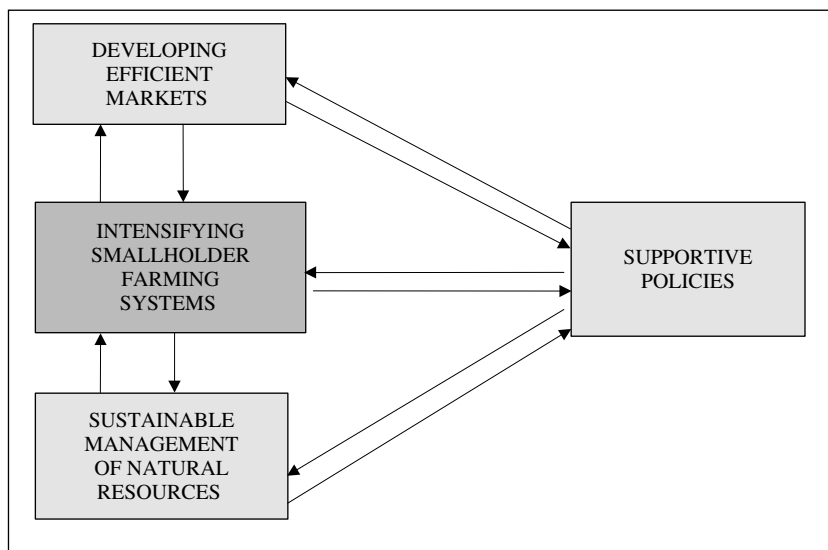

Figure 1. Integration of the four components of the resources-to-policy chain.

the research. The projects will explore, in an integrated manner, the wider dimensions of the constraints, including gender biases and they will be demand-driven and executed by multi-disciplinary teams from different organisations. The teams will be committed to building capacity and to adapt as the dimensions of the constraints are realised and confronted. They will improve methodology and capacity for IAR4D and, as such, will present plausible and persuasive links (impact pathways) connecting the proposed activities and expected outputs and the achievement of the Programme's goal.

The Sub Saharan Africa Challenge Programme will also have supporting activities in the area of organisational change, knowledge management and capacity building. The *organisational change* activities will involve facilitation and mentoring provided to promote action research by assisting in:

- enabling the participation of weaker NARS by helping bring them up to speed
- enabling partners from different disciplines, backgrounds and with different capabilities to interact and participate effectively
- building teams' capacities for self assessment, learning and adapting
- capturing, transferring and internalising successful approaches and methods between teams
- internalising monitoring and self evaluation

Knowledge management will involve ensuring that research outputs are taken up across sub-Saharan Africa taking advantage of contrasting socio-economic and ecological environments in the different sub-regions for methodological development. It will entail synthesis and dissemination of experiences and outcomes with information exchange and knowledge management for rapidly sharing methods between teams

The IAR4D approaches and outcomes will be scaled out by involving communities in the neighbourhood of the research sites including civil society, community based organisations, NGOs and private enterprise, schools producing future farmers and children (future farmers) both as beneficiaries and main actors.

Complementary activities are proposed for strengthening the capacity of the cadres that are expected to take up and support IAR4D by strengthening the teaching of IAR4D principles in African universities (Kaufmann and Temu 2003). This will involve enhanced African inter university collaboration and establishing means for African university faculty to draw on northern universities for pedagogical support and on

the CGIAR centre for relevant and up-to-date locally relevant research products and opportunities for joint development of teaching materials. It will also provide opportunities for scientists from countries without IAR4D sites to join teams in other countries.

IAR4D creating the conditions for achieving greater impact

The purpose of the Sub Saharan Africa Challenge Programme (SSA CP) is to change the way agricultural research is conducted and out scaled and up scaled so that it will have impact on a continental scale in line with the expectations of CAADP. As stated above, it will do this by ensuring local relevance and impact by implementing Integrated Agricultural Research for Development (IAR4D) which will be conducted by multi-institutional multi-disciplinary teams and involve stakeholders in all aspects of the production for consumption chain, or in the case of beverages such as coffee it will extend from seed to sip, including market agents and policy makers.

IAR4D is an innovation systems approach to agricultural research for sustainable development that can accommodate the rapidly changing contexts in which development has to take place (Clark 2001). This requires more sophisticated understanding of how development occurs and recognizing that innovation has multiple sources and results from the actions of a variety of actors. These actors come from a large number and range of organisation associated with agriculture and rural development including but not limited to NGOs, private companies, farmer-operated enterprises and research foundations.

IAR4D will require new working practices involving partnerships and grass-roots participation (Daane and Booth 2003). It recognises that knowledge is increasingly important in the global economy with which development must cope. In addition to disciplinary and basic research skills researchers and trainers need:

Hard systems skills

- the ability to put their discipline in a dynamic systems context
- integrate the contributions of different disciplines
- understand different disciplinary paradigms

Soft skills

- To develop partnerships and manage change with multiple stakeholders in the agricultural sector and wider society

- Build and manage interdisciplinary and inter-institutional teams
- Empower other stakeholders to enter into effective dialogue.

IAR4D creating the conditions for achieving greater impact:

Agricultural scientists have not been at the forefront of developments in the organization of innovation systems but they are beginning to catch up and the proponents of the Sub Saharan Africa Challenge Programme took a bold step in advocating such an approach in the shape of IAR4D. In essence IAR4D creates opportunities for organizational and individual learning hence the use of the terms Pilot Learning Area and Pilot Learning Teams.

Learning is a process for acquiring skills and knowledge. It occurs through mechanisms that reflect the different nature of the subject being learnt. In agricultural development it can occur through learning-by-doing or learning-by-adaptation. With progress it can evolve to learning by imitation when technology is simply replicated and learning by design when technology is changed and improved. Ultimately there is technical learning, which is the capability to develop the whole concept and to transfer it to others. There is also non-technical learning which encompasses the organizational, managerial, financial, marketing and political functions involved in any business including smallholder farming.

As a conceptual framework IAR4D refers to a new understanding of agricultural innovation as an interactive process in which enterprises in interaction with each other and supported by institutions and organizations such farmers' organizations, research and development agencies, marketing organizations and credit institutions play a key role in bringing new products and process and new forms of organization into economic use. The innovations systems approach of IAR4D supersedes the sequential research-extension-adoption approach to agricultural development that has failed to have sufficient impact in improving African livelihoods. It recognises that all stakeholders have important roles to play in the design and conduct of the research to ensure that there are no unforeseen obstacles to adoption of supposedly proven technologies as happened so often in the past.

IAR4D will be conducted at Pilot Learning sites by Pilot Learning Teams involving all stakeholders in the production to consumption chain including smallholders, marketers and policy makers. There research

priorities will not be preconceived by scientists and as such may address any topic however there will still be a tight focus provided by concentration on resolving the constraints identified with the communities.

The innovation systems approach draws attention to the behaviour of local actors with respect to three key elements in the innovation process; linkage, investment and learning. This approach is particularly useful in highlighting policies and routine interactions that lead actors to develop sets of habits and practices with respect to innovation. Unless these are changed to be more conducive to innovation by smallholders and pastoralists African agricultural development will not achieve what is demanded of it in CAADP and Africa will not meet the objectives of NEPAD nor the Millennium Development Goals.

Acknowledgements

The concepts in the paper are drawn from the inputs of the great many farmers, extensionists, development agents and scientists who have contributed to the development of the projects referred to. The author is grateful to Dr. Mike Swift, former Director of TSBF for presenting this paper on his behalf when he was at the last minute unable to present it himself. The paper is dedicated to Hanning Frederick von Kaufmann an outstanding African farmer, innovator and community servant who passed away at the time of the AFNet symposium.

References

- Alston J.M., Chan-Kang C., Marra M.C., Pardey P.G., and Wyatt T. J. 2000 A meta-analysis of rates of return to agricultural R&D. IFPRI research report no. 113. International Food Policy Research Institute, Washington D.C. USA.
- Amoako K.Y. 2003. *Harnessing Technologies for Sustainable Development in Africa*; 5th Annual Peter Doherty Distinguished Lecture, International Livestock Research Institute, Addis Ababa, Ethiopia, 10 April.
- Anderson J. 2003. *Nature, Wealth, and Power in Africa: Emerging Best Practice for Revitalising Rural Africa* (Discussion draft). USAID, Washington D.C..
- Clark N. 2001. *Innovation Systems, Institutional Change and the New Knowledge Market: Implications for Third World Agricultural Development*. The United Nations University Institute for New Technologies (UNU/INTECH) Discussion Paper Series No. 2001-10, Maastricht, The Netherlands.

- Daane J. and Booth R. 2003. *Developing Capacity in Agricultural Research for Development The ICRA Initiative*. Presentation to the 2nd Meeting of the ACP Informal Working Group on Science and Technology with emphasis on Agriculture November 28–December 03, Wageningen, The Netherlands.
- Kaufmann R. von and Temu A. 2003. *Building Africa's Scientific and Institutional Capacity (BASIC): A proposal to FARA on the BASIC requirement for Africa's development*. Paper presented to 2nd Meeting of the ACP Informal Working Group on Science and Technology. November 28–December 03, CTA Ede, The Netherlands.
- NEPAD 2003. Comprehensive Africa Agriculture Development Programme, New Partnership for Agricultural Development (NEPAD), Midrand, South Africa.
- Nweke F.I., Lynam J.K. and Spencer D.S.C. 2002. *The Cassava Transformation: Africa's Best-kept Secret*. Michigan State University Press, East Lansing, Michigan.
- Pardey P.G., Roseboom J. and Beintma N.M. 1997. Investments in African agricultural research. *World Development*, 25(3): 409–423.

From Thousands to Millions: Accelerating Agricultural Intensification and Economic Growth in Sub-Saharan Africa

Maatman A.¹, Wopereis M.C.S.², Debrah K.S.³ and Groot J.J.R.⁴

¹Chief of Party 'From Thousands of Millions', IFDC Africa Division P.O. Box E 103 Bamako, Mali; ²Director, Annual Crops Department CIRAD TA 70/09 Avenue Agropolis 34398 Montpellier; ³Chief of Party MISTOWA, IFDC Africa Division, Orphan Crescent, Labone, Accra, Ghana; ⁴Director, IFDC Africa Division, P.O. Box 4483 Lome, Togo

Abstract

Agricultural growth rates of about 6% are required in sub-Saharan Africa to fuel economic growth. It is generally acknowledged that this will require sustainable agricultural intensification through the increased use of external inputs, in combination with locally available soil amendments, *i.e.*, integrated soil fertility management (ISFM).

Over the last five years and in 16 pilot areas in West Africa, IFDC and its partner organizations in the Agricultural Intensification in Sub-Saharan Africa (AISSA) network have developed the Competitive Agricultural Systems and Enterprises (CASE) approach. The approach is holistic in the sense that it involves all stakeholders of the agribusiness system at the grassroots level, including smallholder farmers, local entrepreneurs, traders, bankers, and facilitating agents. It is dynamic as it fosters both technological and institutional change through experiential and social learning processes. ISFM and Commodity Chain Development are basic concepts and all project activities purposely foster empowerment and strengthen the innovative capacities of local stakeholders, without substituting for the market.

We estimate that about 60,000 farmers and 200 local entrepreneurs have benefited from AISSA-related activities on agricultural intensification in West Africa. To accelerate and extend processes of agricultural intensification, bottom-up grassroots approaches have an important role to play. However upscaling can only be sustainable when, at both local and regional scales, enabling institutional and policy environments for market development exist. IFDC is involved in a number of projects that aim to improve the conditions for ISFM-based agricultural intensification at the regional level, by means of partnerships with farmer-based organizations, traders' associations and government structures (the fertile triangle). Collaboration with the West African Economic and Monetary Union (UEMOA) and the Economic Community of West African States (ECOWAS) is also instrumental in reinforcing efforts to establish common agricultural policies for West Africa, to improve the transparency and competitiveness of agricultural inputs markets, and to nurture the expansion and professionalism of the private sector. The interests of small-scale farmers are safeguarded and the environment is protected.

The approach – combining bottom-up and regional-level projects to promote and scale-up agricultural intensification processes – is not a blueprint package. It offers opportunities for effective participation of all stakeholders involved, partnerships with facilitating institutions, and perspectives to move from thousands to millions of farmers.

Introduction

Despite years and sometimes large amounts of international assistance, the gap between rich countries and sub-Saharan Africa is only widening (IFPRI, 2002). Country assessments of poverty that have been

undertaken during the last decade show that 30%–50% of the population in sub-Saharan African countries lives below the poverty line (Sijm, 1997). It is also known that the rural population is relatively over-represented in this group. Probably for decades to come, most of the poor will remain rural (Cohen, 2001). The

vulnerability of rural livelihoods is related to a large complex of factors, including the relatively unfavorable agro-climatic conditions for agricultural production, increasing scarcity of fertile soils, inappropriate agricultural policies and market failures, and significant social and political disruptions. International trade and (labor) migration policies and measures (i.e., direct or indirect subsidies) to fire up agricultural production elsewhere in the world increasingly affect the lives and economic opportunities of the rural population in sub-Saharan Africa and despite the promises rarely to their benefit (Bigman, 2002a).

Notwithstanding these general facts and factors, rural populations in sub-Saharan Africa are working hard to improve their lives; many of them succeed despite the harsh circumstances. The success stories of populations in sub-Saharan Africa are rarely brought before the court of public opinion. Doom narratives apparently sell better (Roe, 1991). At the end of the tunnel there always is a prescription – tough and bitter as good medication has to be. The African success stories challenge the suggestion of a simple blueprint solution, and the (hidden) idea of the exclusive problem-solver (Schweigman, 2004). They tend to underline the complexities of processes of change and development and the numerous stakeholders involved in transforming rural society at both the local and regional levels (Eicher, 2004). There obviously is no simple prevention for poverty.

A combination of local initiatives, infrastructural works and enabling policies are often the basis for pathways of change. IFDC and partner organizations are collaborating actively at both grassroots and international levels to accelerate processes of change and to improve the performance of agriculture and related industries in sub-Saharan Africa. This paper gives an overview of some of these activities, concentrating in particular on the results obtained by the integrated soil fertility management (ISFM) project, which reaches thousands of farmers. Significant emphasis is placed on strategies and partnerships to be developed for wide-scale impact to reach millions of farmers.

Agricultural intensification and ISFM

Why intensify?

To sustain still growing rural and urban populations and to maintain a strong agricultural sector, agricultural production must grow substantially. According to the

New Partnership for Africa's Development (NEPAD) (2003), agricultural growth rates of about 6% are required. However, the potential for extension of the agricultural area is limited. Besides lowland areas, mostly marginal and forested lands remain, and they would be better conserved for ecological reasons. Therefore, increasing agricultural production per hectare (intensification) offers the most plausible option. It is generally acknowledged that this will require the increased use of external inputs in combination with locally available soil amendments.

A short overview of fertilizer consumption trends

Fertilizers are without doubt part of a solution to correct environmental degradation and properly address rising food demands. Few African countries produce fertilizers. As a consequence, most of the fertilizers that are used in Africa are imported. Jayne *et al.* (2003) conclude that fertilizer consumption in sub-Saharan Africa has grown during the 1980–89 period and the 1996–2000 period from 0.83 million tons, to 1.10 million tons, a 32.5% increase (IFDC, 2002); fertilizer use per ha increased by 5% (Jayne *et al.*, 2003). However, average fertilizer use in Africa is still very low, about 8 kg ha⁻¹ (i.e., only one-tenth of the world average). Most countries apply an average of 5–35 kg ha⁻¹ of fertilizers (calculated as total consumption of fertilizers per ha of annual and permanent crops). Only Zimbabwe has much higher rates and approaches the rates of Latin America (55 kg ha⁻¹).

There are large differences in fertilizer consumption rates and trends between the various countries. In some countries like Nigeria (which consumes about 25% of all fertilizers used in sub-Saharan Africa) and Ghana, fertilizer use rates dropped sharply after the subsidies on fertilizers were reduced. In Ghana, however, fertilizer consumption is recovering and approaches pre-reform levels (Jayne *et al.*, 2003). In some West African countries (Burkina Faso, Togo, Benin and Côte d'Ivoire), high growth rates of fertilizer use were observed, closely related to the expansion of the cotton sector (Jayne *et al.*, 2003). There are also large differences between countries and regions with respect to the crops and cropping systems for which fertilizers are being used (Yanggen *et al.*, 1998). In East Africa fertilizer consumption is largely oriented on food grains, whereas in West Africa consumption is dominated by cotton. Demand for rice and horticultural production is, however, growing in many countries. Rice production

in Mali has spectacularly improved in response to deliberate and well-focused policies of liberalization and decentralization and support to farmer organizations and an emerging private sector. The response has been most impressive and quick in the Office du Niger region but also extends to other rice-producing areas. In West Africa there is a slight tendency toward increased use of fertilizers on food crops, instead of using it for the traditional export crops (cotton). Maize production, in particular, has substantially grown in the Guinean zones of West Africa, due to the use of improved varieties, better agronomic practices, and the use of fertilizers (Sanders *et al.*, 1996). However, its growth has been constrained over the past few years by the reduction in fertilizer use in Nigeria.

Constraints to intensification – based on external inputs

Purchases of external inputs and, in particular, mineral fertilizers, considerably changed financial outlays for agricultural production and given rise to additional financial risks that are determined by (Maatman and Van Reuler, 1999):

- The prices farmers have to pay for the external inputs;
- The costs related to credit;
- The agricultural technology and knowledge about technological options;
- The prices that farmers receive for their agricultural products.

It should be remembered that credit is not always needed to buy fertilizers. Farmers might also use their own financial means to invest in external inputs. Most farmers in sub-Saharan Africa are reluctant to buy external inputs, as a consequence of uncertain supply, the absence of appropriate local credit systems, fluctuating price/value ratios and, last but not least, higher perceived incomes from non-agricultural investments. Some actions that may decrease the financial risks are:

1. Fine-tuning of technological options to improve the (agronomic) efficiency of external input use, including optimal strategies of fertilization according to climatic zone, soil type, and crops cultivated, and complementary measures of soil fertility management and water harvesting (for example, through investments in action-research and extension).
2. Improving the accessibility, both geographically and financially, of external inputs (for example, through the development of infrastructure,

investments in private-sector development and appropriate savings and credit systems, development of effective regulations promoting competitiveness and fair trade).

3. Development of market outlets for agricultural produce (for instance, through the development of agro-industrial enterprises, by diversifying agricultural production, and improved coordination between consumers and producers).

ISFM: a first step

ISFM refers to making best use of inherent soil nutrient stocks, locally available soil amendments, and mineral fertilizers to increase land productivity while maintaining or enhancing soil fertility. Increasing outputs from the same piece of land through agricultural intensification will generally require some use of mineral fertilizers. ISFM-based intensification explicitly focuses on the efficiency of external inputs and addresses the first action point presented in the previous paragraph to decrease the risks of farmers to invest in intensification.

The rationale behind ISFM is simple. First, organic sources of nutrients have low nutrient contents and are usually not abundantly available. Sustaining soil fertility and increasing productivity using organic resources alone is, therefore, a losing battle. Large and often non-available amounts of organic fertilizer would be required to maintain soil fertility levels in each field. Second, the opposite strategy, the unique use of inorganic fertilizers may lead to yield gains in the short term but to serious damage to soil fertility (e.g., acidification) and yield decline in the long term (Pieri, 1989). The best strategy to improve productivity and maintain soil fertility in sub-Saharan Africa lies, therefore, in a combination of both inorganic and organic fertilizers, where the inorganic fertilizer provides (a large part of) the nutrients and the organic fertilizer increases soil organic matter status, soil structure, and buffering capacity of the soil in general. Use of both inorganic and organic fertilizers often results in synergism too, improving efficiency of nutrient and water use (De Ridder and Van Keulen, 1990). Efficient applications of mineral fertilizers will ensure both balanced plant nutrition and maintenance of soil fertility and minimize financial risks. A challenging, continuing task for farmers, researchers, and extension workers. IFDC and partners have developed ISFM technologies in terms of options that enhance soil fertility, productivity, flexibility and – if the prices are right – farmer income.

Facilitating agricultural intensification and market development from the grassroots

Investments in infrastructure; technology development and dissemination; appropriate financing systems; active support to private sector development; and effective coordination between producers, traders, and consumers (urban or global markets) are essential to trigger and sustain agricultural intensification and private sector led market development (Wiggins, 1995). Facilitating institutions can play an important role through the development, validation, and dissemination of ISFM options. However, much more is needed and the development of ISFM options without proper consideration of prices and markets (“Are the inputs available? Are prices affordable? What about the availability and costs of credit, and the market outlets?”) may be totally useless. IFDC and partners have developed the Competitive Agricultural Systems and Enterprises (CASE) approach to overcome this technical bias.

CASE emphasizes the importance attached to competitiveness, both related to the agricultural production systems within the target region and to the rural and urban enterprises that are directly linked to the agricultural production systems, by providing inputs and market outlets. Though the term “enterprise” is not

usually used for services like rural savings and credit banks and even less for extension and research, they are part of the playing field adopted by the CASE approach. The CASE approach is a grassroots approach, but in contrast to many other grassroots approaches, CASE advocates a pro-active role in linking farmers and villages with urban retailers, traders and consumers. The main emphasis is therefore placed on testing and developing alternative institutional arrangements, fostering dynamic and business-oriented farmer organizations with clear economic or advocacy roles, networks of credit structures within the pilot zone and platforms to negotiate land use contracts. The CASE approach is based on two concepts:

1. *ISFM* – discussed above.
2. *The Agribusiness System* (Figure 1). CASE fosters production chain development to decrease the costs of input provisioning and processing and marketing of agricultural produce and improve coordination between producers, and both factor- and product (i.e., final) markets. CASE therefore supports efforts to experiment and extend alternative institutional arrangements that link farmers with input dealers, rural bankers, and traders and strengthens the innovative capacities of the various stakeholders involved.

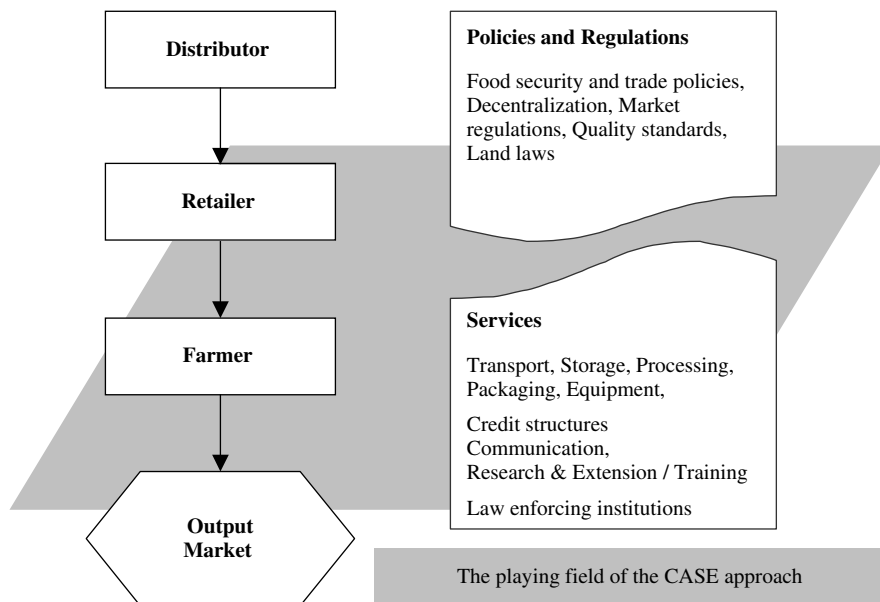

Figure 1. The Agribusiness System.
Source: Adapted from IFDC (1999).

The CASE approach is grounded in experiential and social learning theories and builds on a solid understanding of local settings, indigenous knowledge, and scientific expertise. Two iterative, and partly overlapping participatory learning cycles are used. Each cycle consists of a D(iagnostics), A(ction planning), T(rying things out), and E(valuation) phase: a research-DATE (DATE/R) and an extension-DATE (DATE/E). Both learning cycles address the technological and institutional aspects. The research-DATE builds up new experiences and expertise; the extension-DATE focuses on scaling-up (and -out) of the results. DATE/R focuses mainly on learning centers and groups to advance our understanding of processes to accelerate agricultural intensification. DATE/E provides the link from these knowledge centers and groups to new stakeholders (scaling-up and -out).

In conclusion, the CASE approach is not a technology but a demand-driven approach that fosters production chain development by strengthening the innovative capacities of the various stakeholders including the service providers (e.g., research, extension organizations, NGOs) involved. Farmers and local entrepreneurs themselves identify agricultural production and business opportunities and invest in their own future.

From thousands

Results of the ISFM pilot projects

IFDC and partners have facilitated work on improved and sustainable land management through a number of projects since 1998 in seven West African countries (Benin, Burkina Faso, Ghana, Mali, Niger, Nigeria, and Togo). The projects are sited in 16 target regions that have a potential for agricultural intensification, i.e., with (among other factors) reasonably well-functioning factor and output markets. The projects involve more than 30 governmental and non-governmental organizations as facilitating institutions. Extensive training has been given to staff from the partner organizations (field personnel and supervisors/managers) to strengthen their capacities in participatory approaches, organizational strengthening and facilitation of social learning processes and institutional change. About 3,000 farmers actively participate in learning activities and have formed ISFM farmer groups to develop, validate and disseminate ISFM technologies and to develop and lobby for alternative organizational and institutional arrangements

that may spur agricultural intensification through improved access to factor and output markets. The collaborative activities are usually referred to as the ISFM project. The primary results of this ISFM project are:

1. Adoption of ISFM options: an estimated 60,000 farmers have adopted ISFM technologies on a significant part of their farms. The Value: Cost Ratios of ISFM options adopted are well above two, and returns to family labor are two to six times higher than the average salary in the area. Farm-level incomes of ISFM farmers have increased by 20%–50%. Fertilizer consumption on these farms has increased by approximately 100 kg per ha and is still increasing.
2. ISFM farmer learning groups established in 300 pilot villages are taking the lead in the development and validation of ISFM options for a focused set of marketable products and experimenting with alternative institutional arrangements to improve access to factor (including information) and product markets.
3. Organizational capacities of farmer groups in the pilot areas improved. Farmer groups at the village and regional levels have assumed new roles, e.g., input provisioning, diffusion of information, linkages to credit and savings systems and local and regional traders (including retailers and fertilizer companies).
4. About 200 local entrepreneurs – inputs dealers, traders, managers of warehouses and processing units – have been trained, participated in round table meetings, and work with ISFM farmer groups.
5. Gender awareness increased in the pilot villages and within the facilitating institutions. Women play an important role in the ISFM project activities and related decision-making; they are usually equally represented in the ISFM farmer groups and often have leading roles.
6. Land tenure security improved for ISFM farmers, including female farmers. In some cases, contracts between landowners and ISFM farmers for a sequence of years were established.
7. Capacities of facilitating institutions strengthened. The quality of services provided to farmers and local entrepreneurs has improved considerably.

The ISFM projects implemented by IFDC and its partners are low-budget projects, with emphasis on partnership, capacity building and investments in key activities that otherwise would not have been carried out. Partner organizations leverage resources, combine activities

from different projects and/ or programs to obtain synergy, and are encouraged to work as much as possible with other organizations able to contribute to the dynamics of intensification, whether directly or indirectly (e.g., alphabetization, advice on nutrition, and awareness raising). Inter-institutional collaboration has taken an enormous flight during the last few years of the ISFM project. It is increasingly recognized that no single organization can embrace all activities that are needed to facilitate agricultural intensification. While collaboration between national research and national extension services was not so difficult to establish, open and frank collaboration between national agricultural research and extension services (NARES) and non-governmental organizations (NGOs) was much more difficult. However, the results from the last two years clearly demonstrate that NGOs – the good ones – have competences, in particular related to capacity building, organizational strengthening, institutional developments, and private-sector support that the NARES normally do not have.

The CASE approach demonstrates a feasible pathway to sustainable agricultural intensification. The costs of the CASE approach are low compared to many other approaches, i.e. about \$50 per farmer reached, not counting the traders and other stakeholders that profit from the project. The potential of the CASE approach and the results of the ISFM project only begin to become known and recognized by governments and donor institutions. This is partly because the progressive process, described above, yields visible results only after a tough period of investment in training and learning. It is probably also related to the limited interest that donor institutions – and many governments too – have demonstrated in agricultural development in the 1990s (C. Peacock *et al.*, 2004). The prominent place of agricultural development in NEPAD and the renewed interest of FAO in ISFM-based agricultural intensification prove that these tendencies are changing. It's time to scale-up the results of the ISFM project and other similar projects, within and, if possible, beyond the target areas, aiming not at thousands but at millions of farmers.

The AISSA network

IFDC and partner organizations from the ISFM project have recently formed the Agricultural Intensification in Sub-Saharan Africa (AISSA) network (www.aissa.org). The AISSA network provides a forum

for facilitating organizations to exchange experiences and information, to plan collaborative activities, to produce and diffuse facilitation tools (manuals, guides, etc.), and to lobby for more attention from both the public and private sectors for agricultural intensification (including investments). Facilitating institutions can be the traditional public research and extension services and NGOs but may also include farmer organizations, credit structures, and other organizations that can provide training and other facilitating services.

The combination of institutes involved in the AISSA network is one important particularity of the network. The collective focus on agricultural intensification and (private-sector led) market development is another unique feature. The AISSA network recognizes the fact that capacity building (i.e., the key specialty of the facilitating services) is crucial to accelerate and sustain agricultural intensification and market development, and that no one facilitator can do such a job. Much is being expected from the AISSA network. However, it urgently needs to accommodate memberships from facilitating institutions all over sub-Saharan Africa to become THE learning network on agricultural intensification, i.e., on the practice of facilitating intensification as a multiple stakeholder process on a large scale.

.....to millions

Lessons learned for scaling-up

Over the last five years, many lessons have been learned, both from the successes and the mistakes that have been made. Three main lessons are worth mentioning here because they have had a significant influence on the CASE approach developed, its tools, and its implementation.

1. *Strategic Site Selection and Competitive Analysis.* The first main lesson learned is that the CASE approach only works in regions that already have substantial comparative advantages for agricultural intensification. Competitive analysis of regions, including the assessment of actual and potential industry clusters that link agricultural production systems with local and regional markets, is an essential tool to select target regions.
2. *Systemic Inquiry and Facilitation Skills.* Second, the CASE approach as any other methodology depends on the people who implement it and their capacity to translate theory into practice (and vice-versa). It

is a major challenge to find pathways for action that recognize the heterogeneity of institutions and the diversity and conflicting agendas of the social actors involved. Such pathways build on the legacy of yesterday while creating the institutions that enable markets to function. A process of systemic inquiry, using multi-disciplinary teams and involving facilitators from different institutions, is needed. These facilitators must be able to communicate effectively both with each other and with a large and heterogeneous group of social actors.

3. *Empowerment.* Finally, the CASE approach is based on grassroots initiatives and openly targets the emancipation of farmers and local entrepreneurs. Powerful people can only build competitive agricultural systems and enterprises! Empowerment is a crucial element of the CASE approach. Empowerment is much more than what normally is meant by the increase of capacities. Empowerment is a process by which individuals or groups of people gain control, both over their own lives as over the institutions (including the government) that are supposed to protect their and others' rights. Facilitators and facilitating organizations can play a role in this – an active role, e.g., to assist farmers and local traders in their lobby for more information, for better services from public organizations, for the protection and improvement of their rights and for transparency at all levels of policymaking. Empowerment also plays a role at the grassroots level itself.

All three lessons have important implications for every effort to facilitate agricultural intensification on a large scale. First of all, strategic site selection emphasizes a realistic approach-targeting areas based on their competitive advantages for market-oriented agricultural intensification (Schreurs *et al.*, 2002). The second point, systemic inquiry and facilitation, warns against any blueprint approach. Each region has its own characteristics and potential; its farmers and local entrepreneurs may have specific skills and ways of working, different information networks, and ambitions. Finally, the third lesson, stresses emancipation as a condition for development. It is clearly not enough to focus on the technical skills of farmers and local entrepreneurs. Improved checks and balances in power relationships are crucially needed to enable innovation on a large scale and to provide the incentives for individuals and small economic interest groups to develop and defend their own businesses.

Linking the local and the global

There is a danger in thinking about scaling-up as a way of multiplying pilot projects. Accelerating agricultural intensification through the scaling-up of ISFM and similar projects is, however, not simply a question of reproducing the hard work within a small region to a much larger one. On the one hand, efficient use can and should be made from the lessons learned and the results obtained in the smaller pilot regions to trigger change in the wider region. Farmer-to-farmer exchange and the organization of apprenticeships through trained local entrepreneurs have proved to be very efficient tools to disseminate information and strengthen capacities rapidly at a decreased cost. On the other hand, much more weight needs to be given to (1) commodity chain development and (2) advocacy and lobbying for enabling environments at national and international levels.

(1) Commodity chain development

There is little reason to push ISFM technology on, for instance, maize production, when supply is close to effective demand – also considering farmers' own needs and alternative sources of income to finance the production of maize for home consumption. A supply-push strategy can even prove to be very dangerous and counter-productive (Thurow, 2003). The importance of an agribusiness orientation cannot be easily over-emphasized. Research by the national research institutes in sub-Saharan Africa is still very much oriented toward the staple foods and traditional export crops (Bigman, 2002b). Very little research is done, for instance, on new non-traditional crops or on policy and economic issues. A reversal of thinking in action-research and extension is urgently needed, i.e., concerning cultivars, crops, yield-maximizing efforts, expected profits and income, production methods, and production costs (Bigman, 2002c). Action-research and extension should also focus on new areas such as value-adding processing, storage, and marketing of agricultural products.

Thin markets, poor infrastructures, low levels of employment and incomes in the urban centers, and informal and often exclusive networks of information exchange and trade characterize economies in sub-Saharan Africa. In such contexts, supply-oriented strategies to accelerate agricultural growth will quickly reach their limits, at least when governments or donors

refuse to buy a large part of the surplus production each year, or to subsidize the inputs. Sustainable and private sector-led market development and agricultural intensification needs a more carefully chosen strategy, which considers the whole commodity chain and explores the opportunities for specific regions and industries to develop (and protect) their competitive advantages.

(2) Enabling environments at regional and international Levels

The former argument inevitably leads to the second idea, i.e., that the importance of an enabling environment also grows with the scale of the intensification process. Grassroots approaches are complementary to approaches of a national and even international allure. Where the latter lobby for policies that promote intensification, for instance by stimulating the regional integration of markets or by improving market regulations and taxation policies and strengthening law enforcement, the grassroots initiatives adapt and take advantage of the improved conditions. As the scale of intensification grows, the demand for proper regulations, law enforcement, appropriate market information systems, and other public services will also increase.

IFDC promotes the development of enabling socio-economic and policy environments through a large variety of activities and partnerships. The strategy at the international level is articulated around a fertile triangle composed of farmers' organizations, other stakeholders of the private sector (i.e., traders' associations, industries), and the public sector. Partnerships with national governments have, for instance, produced national action plans for soil fertility investment. Farmer organizations and other stakeholder organizations are supported to improve their capacities to lobby for better policies, to fight corruption, and to improve communication with the regional and local organizations. Market information systems at national and international levels are supported and, if needed, started. Meetings and workshops are organized to discuss and promote improved regulations for the importation and circulation of external inputs, to develop quality control procedures, and to promote investments in private-sector development. Reinforcement of the dialogue between the main stakeholder groups and support to the weakest partners is an important element of the process.

The activities are developed and executed in close cooperation with governments, public services, agricultural input producers, traders and dealers, the financial sector, chambers of agriculture, and farmers' organizations. In certain cases, international organizations such as the Food and Agriculture Organization of the United Nations (FAO), Consultative Group on International Agricultural Research (CGIAR) centers, and international NGOs (e.g., Sasakawa Global, 2000) are also involved. At the international level, discussions and collaborative activities have started with the West African Economic and Monetary Union (UEMOA), the Economic Community of West African States (ECOWAS), the Comité Permanent Inter-états de Lutte contre la Sécheresse dans le Sahel (CILSS) and the Conference of West and Central African Ministers of Agriculture (CMA/WCA) to harmonize regulations and tariffs for a common input market.

Discussion and conclusions

During the past decade, IFDC moved toward a development-oriented institute, facilitating agricultural intensification and private-sector led market development at both the grassroots and international levels. The two-pronged approach developed by IFDC and its partners at the grassroots and international levels is not a blueprint approach, but it offers opportunities for effective participation of all stakeholders involved and for stimulating and creative partnerships of facilitating institutions. IFDC and its partners have already yielded successes by reaching thousands of farmers at relatively low costs. These successes have been achieved by working together at various levels and with different stakeholder groups. For the scaling-up of ISFM options and institutional arrangements developed within the pilot regions and to expand the CASE approach to a larger group of actors, some specific activities have to be strengthened:

1. *Training.* Orient training to a (much) larger group of service providers (NGOs, government organizations) to act as facilitators. Changes of attitude, skills, and to a lesser extent knowledge are essential. Develop new learning groups of farmers and local entrepreneurs and accelerate self-reliance of existing ones and intensify training to emerging local entrepreneurs on product/process knowledge, business management, financing and customer relationships.

2. *Coordination.* Integrate and link CASE activities to other projects and programs within the target regions: this includes awareness raising, coordination of efforts, and lobbying to leverage funds.
3. *Communication.* Strengthen and expand communication strategies, among others, through farmer-to-farmer exchange, rural radio, exchange visits and study tours.
4. *Market Information Systems.* Assist in setting up and/or strengthening of market and other related information systems, including support to capacity-building efforts to enable farmers and traders to select and use information.
5. *Lobbying and Organization Strengthening.* Strengthen lobbying and advocacy groups of farmers and traders at the international level, and facilitate dialogue between policy-makers, farmers and other private sector agents. Give more attention to organizational strengthening and to improve linkages between local, regional, and national level organizations of farmers and other stakeholders (e.g., traders and inputs dealers).
6. *In-depth Research.* IFDC has deliberately reduced its focus on in-depth research, particularly related to agricultural production technologies. Coalitions with research-oriented organizations need to be strengthened to enable IFDC and its partners to stay up to date with new ideas and theories.

To further accelerate sustainable agricultural intensification and economic growth in the target regions and beyond, facilitating services are urgently required to lay the foundations – in terms of learning centers, economic interest groups, lobbying and advocacy groups and platforms, and capacities of service providers. The costs of the facilitating services will be comparable to present levels of investment in ISFM projects, about \$50 per farmer. However, facilitating services do not substitute for the stakeholders own investments in time and money, agricultural intensification, and market development:

- Farmers will need to invest themselves in external inputs and the development of ISFM strategies; they should also invest in organizational strengthening to improve access to factor and output markets and to appropriate information.
- Traders and manufacturers need to invest in local sales-points for external inputs, fabrication of agricultural equipment, and processing and storage of agricultural products.

- Service providers, including savings and credit structures, and transporters need to invest in equipment (e.g., trucks), local offices and customer relations.
- Governments need to invest in public infrastructure and education and should stimulate and facilitate private sector initiatives. Proper legislation and control mechanisms and well-targeted investments might be needed to develop markets and commodity chains.

The costs for scaling-up are high, but the benefits of sustainable agricultural intensification and market development will be priceless. Much can be gained from partnerships between facilitating organizations that have a regional mandate to accelerate agricultural intensification. IFDC is actively pursuing such partnerships in sub-Saharan Africa.

References

- Bigman (Ed.) 2002a. *Globalization and the Developing Countries: Emerging Strategies for Rural Development and Poverty Alleviation*. International Service for National Agricultural Research (ISNAR), The Hague, CABI Publishing.
- Bigman 2002b. Diversifying Agricultural Production and Exports in Africa. In: Bigman (Ed.). *Globalization and the Developing Countries: Emerging Strategies for Rural Development and Poverty Alleviation*. International Service for National Agricultural Research (ISNAR), The Hague, CABI Publishing.
- Bigman 2002c. Introduction and Overview. In: Bigman (Ed.). *Globalization and the Developing Countries: Emerging Strategies for Rural Development and Poverty Alleviation*. International Service for National Agricultural Research (ISNAR), The Hague, CABI Publishing.
- Cohen M. 2001. *2020 Vision: The Prospects for Universal Food Security in the Next Two Decades*. Paper presented at the 42nd Annual International Studies Association Convention, February 2001, Chicago. International Food Policy Research Institute (IFPRI), Washington.
- De Ridder N. and Van Keulen H. 1990. Some Aspects of the Role of Organic Matter in Sustainable Intensified Arable Farming Systems in the West-African Semi-Arid Tropics (SAT), *Fertilizer Research* 26: 299–310.
- Eicher C. 2004. Flashback: Fifty Years of Donor Aid to African Agriculture. Revised version of paper presented at the International Policy Conference, “Successes in African Agriculture: Building for the Future.” Michigan State University, U.S.A.
- IFDC 1999. A Strategic Framework for African Agricultural Input Supply System Development. IFDC, Muscle Shoals, Alabama, U.S.A.
- IFDC 2002. Global and Regional Data on Fertilizer Production and Consumption, 1961/2–2000/1. Muscle Shoals, Alabama, U.S.A.
- IFPRI 2002. Reaching Sustainable Food Security for All by 2020. PDF-file and PowerPoint presentation available at www.ifpri.org/2020_vision.

- Jayne T.S., Kelly V., and Crawford E. 2003. *Fertilizer Consumption in Sub-Saharan Africa*. Policy Synthesis for Cooperating USAID Offices and Country Missions. USAID.
- Maatman A. and Van Reuler H. 1999. Farming Systems Research and the Development of Integrated Nutrient Management Systems: Linking Input/Output Market and Technology Development, In: Renard G., Krieg S., Lawrence P., and Von Oppen M. (Eds). *Farmers and Scientists in a Changing Environment: Assessing Research in West Africa*. Margraf Verlag, Weikersheim, Germany.
- NEPAD 2003. Comprehensive Africa Development Programme. African Union, NEPAD.
- C. Peacock, A., Jowett, A. Dorward, C. Poulton and I. Urey, 2004, Reaching the poor: a call for action. Investment in smallholder agriculture in sub-Saharan Africa. FARM - Africa, HARVESTHelp, and Imperial College London.
- Pieri C. 1989. *Fertilité des terres de savannes: bilan de trente ans de recherche et de développement agricole au sud du Sahara*. Ministère de la Coopération et de Développement Français, Paris, CIRAD, Montpellier, France.
- Renard G., Krieg S., Lawrence P., and Von Oppen M. (Eds) 1999. *Farmers and Scientists in a Changing Environment: Assessing Research in West Africa*. Margraf Verlag, Weikersheim, Germany.
- Roe E. 1991. Development Narratives. Or, Making the Best of Blueprint Development. *World Development* 19 (4): 287–300.
- Sanders J.H., Shapiro B.I. and Ramaswamy S. 1996. *The Economics of Agricultural Technology in Semiarid Sub-Saharan Africa*. The Johns Hopkins University Press, Baltimore, Maryland, U.S.A.
- Schreurs M., Maatman A. and Dangbégnon C. 2002. In for a Penny, in for a Pound: Strategic Site Selection and On-Farm Client-Oriented Research to Trigger Sustainable Agricultural Intensification in West Africa. In: Vanlauwe B., Diels J., Sanginga N. and Merckx R. (Eds). *Integrated Plant Nutrient Management in Sub-Saharan Africa: from Concept to Practice*. CABI publishing in collaboration with the International Institute of Tropical Agriculture (IITA), Ibadan, Nigeria (pp. 65–74).
- Schweigman C. 2004. *Food Security: Opportunities and Responsibilities. Or: The Illusion of the Exclusive Actor*. Valedictory Lecture, November 2003, CDS Research Report No. 19. University of Groningen, The Netherlands.
- Sijm J. 1997. *Food Security and Policy Interventions in Sub-Saharan Africa. Lessons from the Past Two Decades*. Erasmus University Rotterdam, Tinbergen Institute Research Series, No. 166, Rotterdam.
- Snrech 1994. Pour préparer l'avenir de l'Afrique de l'Ouest: une vision à l'horizon 2020: synthèse de l'étude des perspectives à long terme en Afrique de l'Ouest. OCDE/OECD, Club du Sahel, BAD/ADB et CILSS.
- Wiggins 1995. Change in African Farming Systems between the Mid-1970s and the Mid-1980s. *Journal of International Development*, Vol. 7, No. 6, 807–848.
- Yanggen D., Kelly V., Reardon T. and Naseem A. 1998. *Incentives for Fertilizer Use in Sub-Saharan Africa: a Review of Empirical Evidence on Fertilizer Response and Profitability*. MSU International Development Working Paper No. 70, Michigan State University, U.S.A.

Soil science, population growth and food production: some historical developments

Alfred E. Hartemink

ISRIC – World Soil Information, PO Box 353, 6700 AJ Wageningen, The Netherlands, Phone: 0317 471 713, Fax: 0317 471 700, E-mail: alfred.hartemink@wur.nl

“The peoples of the earth, whether they will it so or not, are bound together today by common interests and needs, the most basic of which are, of course, food supply and other primary living requirements. Those come, all of them, from nature and from nature alone – from the forests, the soils and the waterways.”

Fairfield Osborn (1948)

Abstract

The world's population has doubled since 1960. Currently, the developing world accounts for about 95% of the population growth with Africa as the world's fastest growing continent. The growing population has many implications but most of all it requires an increase in agricultural production to meet food demand. Soil science has a long tradition of considering the growth in food production in relation to the increasing human population. This paper reviews some of the major developments in these subjects from a soil scientist's perspective. It starts with the work of Thomas Malthus and various subsequent studies relating population growth and food production. Population growth and projections up to the year 2050 are discussed. The main soil studies since the 1920s are reviewed with a focus on those conducted in the Dutch East Indies and the UK. The productivity of soil science measured by the number of publications and soil scientists has kept pace with the increasing population. Although the number of undernourished people in the world is on the decline, it is concluded that continued efforts from soil scientists remains needed particularly now the focus of attention in the USA and Western Europe moves from population growth *per se* to population ageing and obesity.

Key words: Environmentalism, food production, history, population growth, soil science, Thomas Malthus

Introduction ¹

Soil science is a relatively young science that emerged some 150 years ago. It developed in Europe, North America and the Russian Empire (Kellogg 1974). Soil surveys started in sparsely populated areas where there

was ample land for farm extension and thus a clear need to for soil inventories (e.g. Russian Empire and the USA). In more densely populated Western Europe where land was relatively scarce, research efforts were devoted to maintain and improve soil conditions, and in most European countries soil survey organizations were only established after the Second World War. Soil science has always had a strong focus on increasing agricultural production needed for the increasing human population (van Baren et al. 2000).

¹This is a modified version of chapter 2 in the book “Soil fertility decline in the tropics with case studies on plantations”, by A.E. Hartemink (2003)

One of the most intriguing global phenomena has been the increase in human population. This increase was most dramatic in the past 100 years and has been the cause for debate, which has resulted in a deeper understanding of man's role on earth. Much of the debate is related to food production and the environmental effects of increased land-use pressure due to the growing population. Over the years different views on the effects of a growing human population have been published and in this paper some of the main arguments are discussed including an overview of facts and figures. The aim of this paper is to provide a brief historical overview of studies on the relation between soil science, population growth and food production. Much has been written about these subjects and this paper is not aiming to review all available literature, but to summarize some of the major studies in order to sketch the main trends and developments. It starts at the end of the 18th century – which is some decades before soil science emerged.

Malthus and his followers

Thomas Malthus

In 1998, it was exactly 200 years ago since Reverend Thomas Malthus (1766–1834) wrote “An essay on the principle of population, as it effects the future improvement of Society”. The stimulus for writing this polemic was his concern about the unwarranted euphoria of his colleagues who, in the aftermath of the French revolution, saw mankind progressing ever upwards to a world of universal abundance, peace and prosperity where all would be equal in health, wealth and happiness (Short 1998). He wished to demystify this utopian fantasy, and used his numeracy to point out a simple truth: Population, when unchecked, increases geometrically whereas subsistence increases arithmetically (Malthus 1826).

Malthus' theory on everlasting food shortages and poverty had three basic assumptions: (i) food was considered to be necessary for the existence of man and the sole limiting factor on human population growth, (ii) human population increases exponentially, and (iii) food production could only be increased linearly. His theory explained the scarcities and misery observed in England and he declared food paucity to be ‘checks’ to population growth imposed by the prescribed bounds of nature (Seidl and Tisdell 1999).

Malthus' assumption on exponential population growth was not entirely new and similar views were discussed in demographical research of the 17th and 18th century. His essay that was written in a brilliant way, facilitated the widespread acceptance of his theory. Initially he was abused as his essay was held for unholy, atheistic and subversive of social order (Bettany 1890). A major criticism is that the idea of exponential growth was deduced from growth in North America and it was not observed elsewhere at his time. Population growth in North America was mainly due to immigration, a confounding factor which was initially ignored by Malthus (Seidl and Tisdell 1999). In later editions of the book he slightly altered that view.

Malthus has been named founder of the social demographic discipline, but more importantly, he was one of the first who saw the importance of the environmental limiting factors on human material progress. His essay inaugurated a grand tradition of pessimistic environmentalism (Anon. 1997), which probably found its heydays in the 1960s and 1970s. Although many people in the 19th and beginning of the 20th century thought Malthus was right, he was wrong for he did not foresee the industrial age and the geometric effect of technology upon economic growth (Jensen 1978).

When C. Darwin read Malthus' essay in 1838 he saw the struggle for existence which inspired him for the “Origin of Species” published in 1859. There is thus a substantial influence of Malthus on the most influential biological theory (Bettany 1890; Seidl and Tisdell 1999).

The population bomb

After Darwin, the most renowned biologist and follower of Malthus is P. Ehrlich, who published in 1968 the book “The Population Bomb”. The book became an instant best-seller and ran through several editions bearing slightly different names but the same message. Ehrlich's message was similar to Malthus: unchecked population growth will outstrip food production and destroy the earth's environment (Ehrlich 1968). The book contains a detailed and pessimistic account of what will happen when the population growth continues. Inevitably there will be mass starvation and the 3.5 million who starved to death (in 1968) would only be a handful compared to the numbers that will be starving in a decade or so in addition to the massive environmental degradation. In the foreword, Ehrlich states “In a book about population there is a temptation to stun

the reader with an avalanche of statistics. I'll spare you most, but not all, of that". The few hard figures and projections given have not come out. For example, it was projected that there would be over seven billion people in 2000, a figure that was also used by the Club of Rome (there were six billion people in 2000), and the population in Calcutta would have reached 66 million by 2000, whereas the actual population in 2000 was around 11 million.

Ehrlich, being a scientist, included a small section in his book entitled "What if I'm wrong?" in which he states that the possibility exists that "...technology or a miraculous change in human behavior or a totally unanticipated miracle in some other form will save the day" (Ehrlich 1968). He found that highly unlikely but played it safe: "If I'm right we will save the world. If I'm wrong, people will be better fed, better housed, and happier, thanks to our efforts". Not a modest view and impossible to substantiate.

It is likely that Ehrlich's books inspired groups like the Club of Rome, which was formed and headed by the Fiat director A. Peccei. Their study "The Limits to Growth" which was published in 1972 entailed what would happen if economic growth and population growth continued. It had the following supposition: "The basic behaviour mode of the world system is exponential growth of population and capital, followed by collapse". A model was built to investigate five major trends of global concern: accelerating industrialization, rapid population growth, widespread malnutrition, depletion of non-renewable resources and a deteriorating environment. Calculations were made by a team of the Massachusetts Institute of Technology and the results were shocking as most natural resources would be depleted within 100 year or sooner (Meadows et al. 1972). Moreover the study was pessimistic about the future of the land resources and advocated that the Green Revolution only caused widening inequalities and disruptions of stable societies. It is no exaggeration to note that "The Limits to Growth" study was momentous – partly as it was conducted by computer (so it had to be right) and initiated by an industrialist (a capitalist so not a person from the green movement). Despite the various predictions made in "The Limits to Growth", growth continued exponentially and many of the projections proved false with the comment on the increase of CO₂ in relation to climate change as the most noteworthy exception.

A different sound from Malthus and his more or less faithful followers came from E. Boserup's study entitled "The conditions of agricultural growth" (Boserup

1965). Contrary to the common reasoning which is that the supply of food for the human race is inherently elastic and that this lack of elasticity is the main factor governing the rate of population growth, she advocated that population growth is an independent variable which in its turn is a major factor determining agricultural developments (Boserup 1965). The growth rate of food production will accelerate when population grows since it forces the population to intensify land-use and increased use of inputs. This holds as long as fallow land is available and the population density threshold value has not been reached. In summary: agricultural developments are caused by population trends rather than the other way around. Her viewpoints were largely ignored by both Ehrlich and the Club of Rome whose studies fell in much more fertile public grounds. The reasons hereto may be related to the fact that there was ample food in Europe and the USA and that the post-war babyboom generation felt a need to change the world.

Facts and figures

Historical estimates of world population are published at the website of the US Government on population census (www.census.gov/ipc/www/worldhis.html). Estimates are based on various sources and the mean of the upper and lower boundary for the period -10000 BC to 2000 AD and the period 0 to 2000 AD is shown in Figure 0. Global population hardly changed up to 1000 BC and slightly decreased in medieval times. The real increase started from 1650 onwards when global population passed through the "J-bend" of the exponential growth curve. Population growth remained below 0.5% up to 1800 and was about 0.6% in the 19th century. In the first half of the 20th century growth was 1%, but the largest rate occurred in the second half of the 20th century when the world population grew over 2% in some years.

What has caused the exponential increase in human population since the 1600s? The main reason is science and technology – in particular medical, industrial and agricultural sciences. The conquest of infectious diseases in infancy and childhood and other medical inventions are the main contributors to the exponential growth of the human population. Another factor is the decline in traditional breastfeeding practices by urbanisation and by the premature introduction of animal milk or infant milk (Short 1998). Also the increase in food production in Europe in the 17th and 18th century

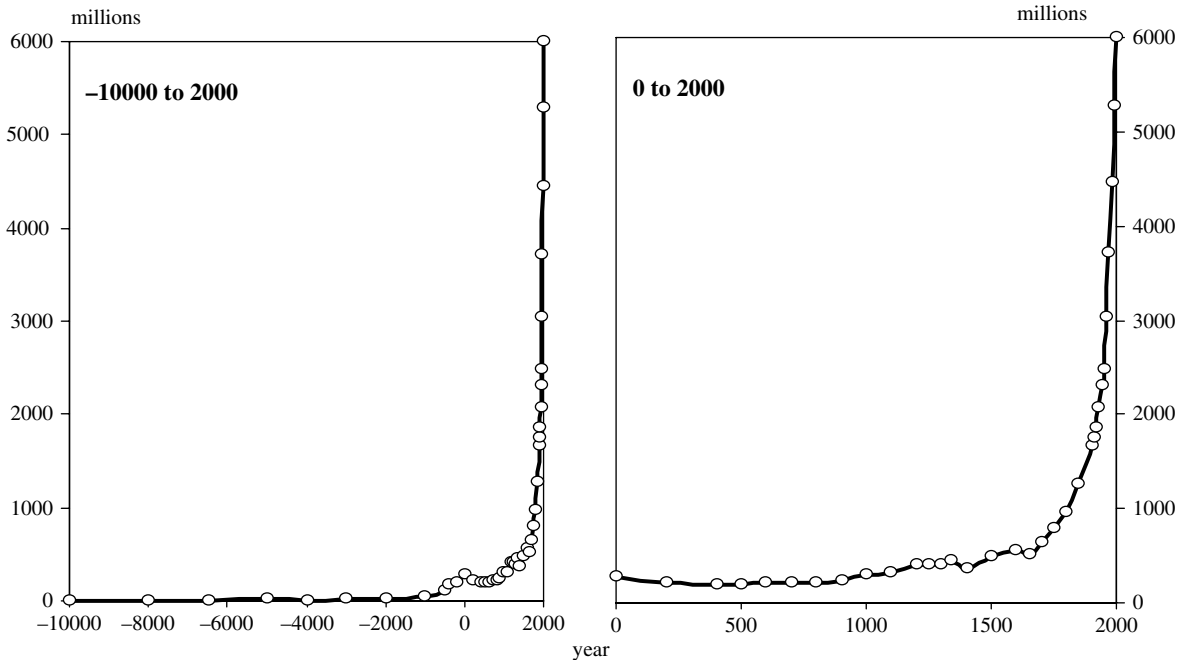

Figure 0. World population estimates for the years –10,000 BC to 2000 and the years 0 to 2000. Based on reconciliation of published data.

due to advanced cultural techniques (ploughing, liming) and more stable societies resulted in an increase in human population. Important inventions like the acidulation of bones by J.B. Lawes and technological marvels like the Haber-Bosch process that allowed the industrial production of urea indirectly caused a large increase in the European population. These were highly important and the invention and extensive use of superphosphate probably resulted in the economic domination of the world by Western Europe, according to Greenland (1994). Factors explaining the strong population growth in tropical regions were the abolishing of the slave trade, the suppression of tribal wars by European colonists, improvements in the health systems and the relieving of famine (Nye and Greenland 1960). Most of these factors became only significant in the 20th century.

Food production and soil science

Whether agricultural development is governed by population growth (Boserup 1965) or vice versa like Malthus and his followers proclaimed, the fact remains that more food needs to be produced when the population grows and if starvation is to be avoided. In

the absence of massive food relocation, the extra food needs to come from either the available land through intensification, better crop husbandry practises and new high yielding varieties (yield increases) or through taking more land into production (area increases). Both production increase and area increase are dependent on a thorough knowledge of the soil and technological applications of this knowledge. Soil science, being essentially an interdisciplinary and applied science, has a long tradition of considering increased food production for the growth of the human population. This emerged in the 1920s (e.g. Penck 1928) and continues to date (e.g. Bouma et al. 1998; Greenland et al. 1997) and the next section reviews some early and recent studies in which soil science, population growth and food production are linked.

At the first Congress of the International Society of Soil Science (ISSS) in 1927, it was suggested that the world could feed at a maximum 15.9 billion people although at that time 7.7 billion was considered a more likely figure (Penck 1928). The estimate was largely based on the climatic maps of the world by Köppen as soil maps of the world were not available. The human population in 1927 was 1.8 billion of which 72% lived in the temperate zone. Penck (1928) quite correctly foresaw a dramatic increase in the human population

and that most of the increase would occur in the tropics, which was first expressed in the early 1900s. The growing human population and the adequacy of food production were a point of concern in both the British Empire and in the Dutch East Indies although commercial developments had usually higher priorities than smallholder agriculture in the tropical colonies.

British studies

Prior to the Second World War, British administrators felt responsible for the feeding of the increasing population that had followed the cessation of war in many of their colonies and territories. Sir A.D. Hall, the first director at Rothamsted Experimental Station after J.B. Lawes, summarised the situation in the mid 1930s as follows “...native agriculture especially in those vast regions of Africa for which we are responsible, is inadequate to provide for the growing population, that is leading to land hunger and political unrest, that is wasting and will eventually destroy even the present limited production from the land”. He stated that the increase of population in Africa has become very marked since the advent of European government, and in many tribes land hunger has developed already to an alarming degree. Unless remedial measures are taken, a state of general congestion is threatened within 30 years and famine is never far away (Hall 1936). He strongly believed that an increase in the amount of available food and the raising of living standards would be accompanied by an automatic reduction in the rate of increase of the population. That point has not been reached yet in Africa.

Hall’s successor Sir E.J. Russell, who was Rothamsted’s director for 31 years, showed great interest in the relation between human population growth and soil science and published a thorough book on the subject (Russell 1954). In the book’s preface he mentioned that there have always been great inequalities in the food supplies of different countries. Prior to the Second World War such inequalities were accepted as part of the natural order of things which it was not for us (i.e. North-West Europeans) to interfere. He added that in the 1950s and 1960s many people in Europe and their descendants overseas had a growing feeling that they must do something to mitigate the hunger that oppresses so many in the undeveloped countries. That argument which was deeply-rooted is still with us today, particular in soil science.

Dutch East Indies

The link between population growth and soil science was recognised in the Dutch East Indies (Indonesia) and in particular on densely-populated Java. Based on earlier work, E.C.J. Mohr showed that Indonesia had a mean population density of 32 people km⁻² in 1930 but with large regional differences: Java carried 316 people km⁻² whereas population density in some parts of Sumatra and Borneo (Kalimantan) was only 11 people km⁻². The soil made all the difference: Java is largely volcanic and most fertile soils are derived from volcanic ejecta which also affects the quality of the irrigation water which is highly important in the rice based farming systems of Java (van Baren 1960). Mohr (1947) compared population densities for different districts near the active Merapi Volcano in Central Java (Indonesia) on volcanic soils and non-volcanic soils derived from limestone. Much higher population densities were found in the area where regular ash deposits are made by the volcano (Figure 1).

Further studies relating soil properties to population density showed that they were closely linked and the problem of the pressure on the land from an ever increasing growth of the population should take this into account (van Baren 1960). Transmigration of people from Java to sparsely populated regions of Sumatra, Papua or Kalimantan was a way in which both the Dutch colonizers and successively the Indonesian government dealt with the growing population on Java’s fertile soils.

White (1941) considered soil fertility as a matter of national concern in relation to the rapidly growing population on Java. It is interesting that he considered two types of soil fertility loss: “emigration” of soil fertility through export crops, and “transmigration” through transport of produce within the archipel. He was amongst the first to consider the soil fertility conditions of the local farmers since most research in the Dutch East Indies was focused on large-scale plantations. The situation was no exception as soil science in the tropics prior to the Second World War largely focussed on plantation agriculture (Hall 1936). Knowledge on the soil resources of the Dutch East Indies increased rapidly in the 20th century. C.H. Edelman compiled a bibliography of soil science publications in the Dutch East Indies and from this it was calculated that there was on average 5.0 publications per year between 1850 and 1900, 44.4 publications per year between 1900 and 1925 and it had increased to 63.3 publications per year between 1925 and 1940.

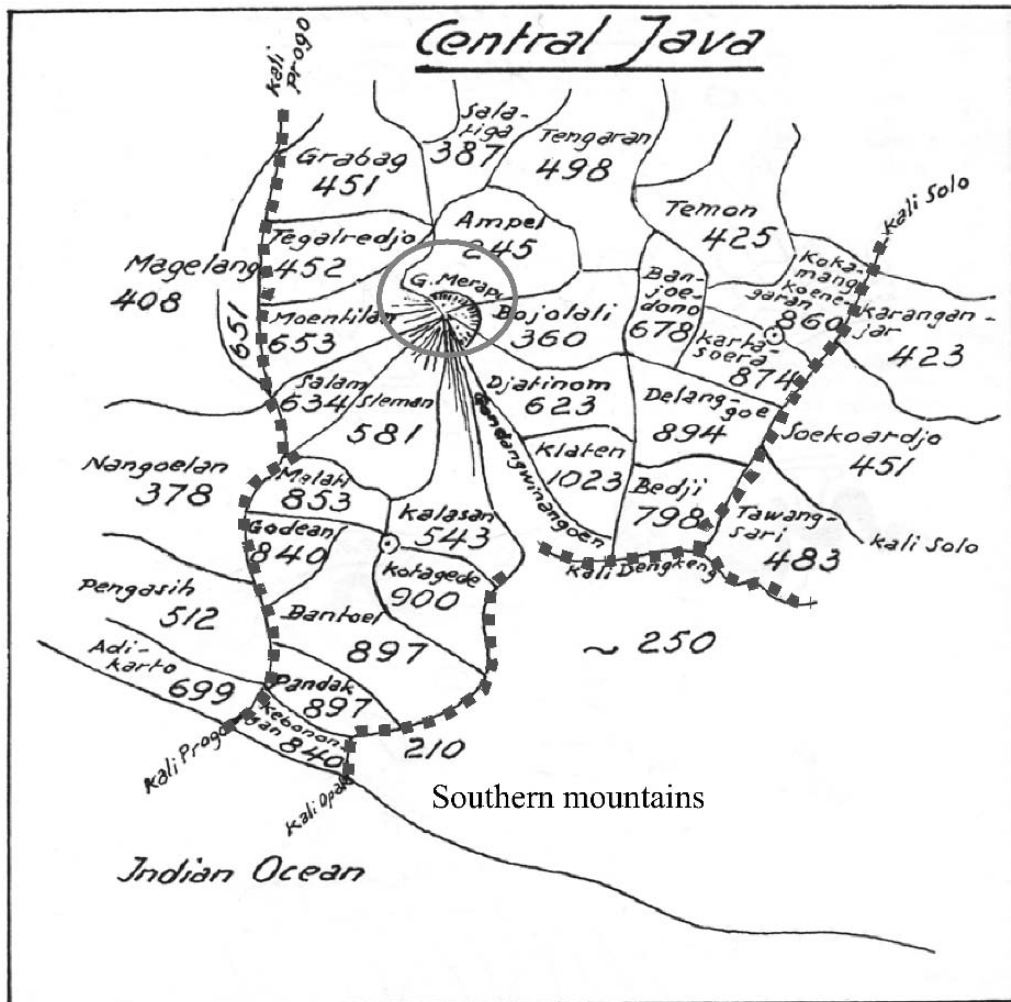

Figure 1. Population density (persons km⁻²) around the Merapi Volcano (Central Java) in the 1930s. The Merapi Volcano (encircled) is an active volcano that regularly ejects lava and ashes that are deposited between the Pogo River in the East and the Opa and Solo in West (dotted lines). Soils in the Southern Mountains are generally poor. Modified after Mohr (1947).

Soil erosion and environmentalism

Soil erosion emerged in the first half of the 20th century as an obvious factor affecting food production in relation to the expanding human population. In the USA there was the question whether sufficient food could be produced for the growing population followed the “dustbowls” in the 1930s caused by severe erosion by wind. The New York Times stated in 1937 that if soil erosion was allowed to continue hunger would be common in the USA. This coincided with a serious economic depression in the USA, and an active

fight of President F.D. Roosevelt against both depression and soil erosion. It resulted in the establishment of the Soil Conservation Service and the belief that productive soils can be maintained through centuries of farming if serious erosion is prevented (Bennett 1939).

A global overview of soil erosion was prepared by Jacks and Whyte (1939) titled “The rape of the earth – A world survey of soil erosion” (the American expurgated title was “Vanishing Lands”). They arrived at similar conclusions: the world food production was seriously affected if erosion would remain unchecked.

Depressing views on the future of the earth were also expressed in “An agricultural testament” (Howard 1940), “Our Developing World” (Stamp 1960) and “Our Plundered Planet” (Osborn 1948), containing quotes like “.. It is easy to understand in present times, with the world so crowded and in need of food, how any overpopulated country might deplete its land in a desperate effort to feed its crowding millions.” The cover of “Our Plundered Planet” from 1948 stated “...we are more likely to destroy ourselves in our persistent and world-wide conflict with nature than in any war of weapons yet devised.” The threats of the cold war and atomic weapons had yet to arrive in 1948. It is certainly not the case that soil science embraced the conclusions of all these books and the well-known Dutch soil scientist C.H. Edelman rightly called them “scare books” (Edelman 1951). He was also convinced that man is inventive so that a much larger human population would be possible provided modern agricultural techniques were available in developing countries.

Although environmentalism is generally associated with the 1960s and 1970s, these “scare books” make clear that the seeds for a pessimistic environmental outlook were sown in the first half of the 20th century (e.g. Hall 1936; Howard 1940; Jacks and Whyte 1939; Osborn 1948). As explained earlier, it was not until the 1960s that similar views gained widespread attention and acceptance. After the Second World War when international organisations such as the FAO were established and many countries were aiming at independence, the feeding of the growing population became an important area of research. Increasing food production was a concern in Western Europe because of the devastation after the war and the babyboom. Fortunately, science came out of the war with high status and was overall respected (Tinker 1985). There was great optimism and positivism in the 1950s and agricultural research rapidly expanded. Most, if not all, agricultural research was directed towards agricultural production, which increased dramatically, thanks to technological developments and major investments in agricultural infrastructure. Even though the term “green revolution” is mostly being reserved for agricultural production in developing countries, it could apply as well to post-war agriculture in Western Europe (Bouma and Hartemink 2002). There is no doubt that soil science played an important role in the increase of agricultural productivity, and Malthus would have been correct in predicting that population growth would outstrip food supplies but for the discoveries of soil scientists (Greenland 1991).

Soil science achievements

Various books and journal articles have reviewed the history and developments in soil science (Greenwood 1993; Hartemink 2002b; Russell and Williams 1977; van Baren et al. 2000; Yaalon and Berkowicz 1997). In addition, detailed reviews on developments in soil chemistry (Sparks 2001), soil physics (Raats 2001), soil microbiology (Insam 2001), soil variation (Heuvelink and Webster 2001) were recently published. These reviews all show the enormous progress that has been made in our understanding of the fundamentals of soil properties and processes. At the same time the reviews show in which areas (e.g. agriculture or the environment) soil science has made major contributions.

Lal (2001) summarised the cause of increased food demand in the 19th and 20th century and a number of causes were related to the soil and its management: ploughing, terracing, soil erosion control, irrigation and soil fertility management through manure and inorganic fertilisers. Mermut and Eswaran (2001) reviewed the developments in soil survey and mapping, soil technology, soil microscopy, pedology and classification of soils, and the mineral and organic components of soils. Several technologies have emerged from these developments including agroforestry, conservation tillage and precision agriculture. Major progress has been made in environmental soil science, and soil science has also been instrumental in studies on land degradation and sustainable use of natural resources and in studies on carbon cycling and sequestration (Mermut and Eswaran 2001).

Recent soil science and food production studies

At the international level, soil science and food production became closely linked in the 1960s and the motto for the 7th International Congress of Soil Science in 1960 in Madison was “Alleviate Hunger, Promote Peace through Soil Science”. In his presidential address R. Bradfield mentioned that he can think of no single group of scientists who have more to contribute to feed the world than this group (Bradfield 1960). He also mentioned, quite correctly, that agriculturists including soil scientists have had more experience and in general more success in increasing food production than population experts have had in population control.

Nearly all studies from the 1930s to the mid-1970s focussed on soil physical and chemical properties limiting agricultural production (e.g. Bradfield 1960; Mohr

1947; Pendleton 1954). These studies were largely qualitative. The first quantitative study estimating the world food production was conducted in the mid-1970s. Following the publication of the report of the Club of Rome (Meadows et al. 1972), the Dutch Nobel laureate J. Tinbergen requested a group of Wageningen researchers headed by the soil scientist P. Buringh to estimate the maximum food production of the world if all suitable agricultural land would be cropped (Buringh et al. 1975). Hereto an assessment was made of land resources and productivity of more than 200 regions of the world introducing the regional aspects of food production and productivity. The absolute maximum production was expressed in grain equivalents of a standard cereal crop and estimated to be 40 times the production in 1975 when there were 4.1 billion people. It was assumed that less than half of the potential agricultural land of the world was cultivated (Buringh et al. 1975). Although the authors admitted that the results have only a theoretical and scientific value, the study showed locations where most productive land is available and that highest possible land productivity is in the tropics where double or triple cropping can be practised.

Characteristic for these early quantitative studies on global food production is the lack of scenarios or uncertainty in the calculations. Analogue to demographic studies which now largely focus on uncertainty *per se* (Lutz et al. 1997), such studies started to appear in the 1990s (Gallopín and Raskin 1998). A study by Kendall and Pimentel (1994) included three scenarios: continuation of present trends whereby population is to reach ten billion in 2050, a pessimistic scenario with 13 billion by 2050 and climatic changes, and an optimistic scenario assuming a population of 7.8 billion by 2050 and improved agricultural practices. In the first scenario food production cannot keep pace with population growth. The pessimist scenario assumed considerable climatic change causing 15% yield loss and gave little hope of providing adequate food for the majority of humanity by 2050. Only the optimist scenario considered that grain production might be adequate for the growing population by 2050 but it would require a doubling of the production and the implementation of soil and water conservation programmes (Kendall and Pimentel 1994). Similar views were expressed by IFPRI (Pinstrup-Andersen 1998).

Another recent estimate showed that a two- to four-fold increase in food production can be easily achieved to satisfy the growing population (Penning de Vries

et al. 1997). The estimate was based on the potential production limited by radiation and temperature, by moisture in rainfed areas and it was further assumed that all surface water is available for irrigation. The authors conclude that actual (or attainable) level of agricultural production will be much lower for land is limited, water use is inefficient and there is loss of productivity because of soil degradation.

Soil degradation was taken into account in a study by Bouma et al. (1998). They explored the effects of different types of soil degradation (compaction, erosion, acidification) on agricultural production. Although the calculated values should not be considered as absolute the study showed that the effects of different forms of degradation cannot simply be extrapolated. So far no study has been conducted which quantified the effects of land degradation on global agricultural production. This is because no accurate data exist on the extent and types of land degradation (Hartemink 2003).

Soil science productivity

One way of measuring the productivity in a branch of science is to count the total number of publications over time for it can be assumed that the number is somewhat proportional to developments and advancements. Figure 2 presents the cumulative increase in soil and agricultural journals and the total number of soil abstracts published annually by CAB International since 1938 (Hartemink 2002a). The first soil science journal appeared at the close of the 19th century and a large number of soil science journals saw the light in the 20th century. Prior to the Second World War, there were only few scientific journals in which soil investigations were published. A considerable number of journals was established directly after the war and another peak occurred in the early 1980s. Only two journals were established in the 1990s and both focus on soil biology (Hartemink 2002a).

The trend in soil science abstracts is somewhat similar to the cumulative number of journals. The main cause for the increase is the growing number of soil scientists which is presently estimated to be 50,000. No accurate data exists on the number of soil scientist over time, but total members of the International Society of Soil Science (now IUSS – International Union of Soil Sciences) is depicted in Figure 2– data from (van Baren et al. 2000). It closely follows the number of CABI abstracts and the cumulative number of journals. It has

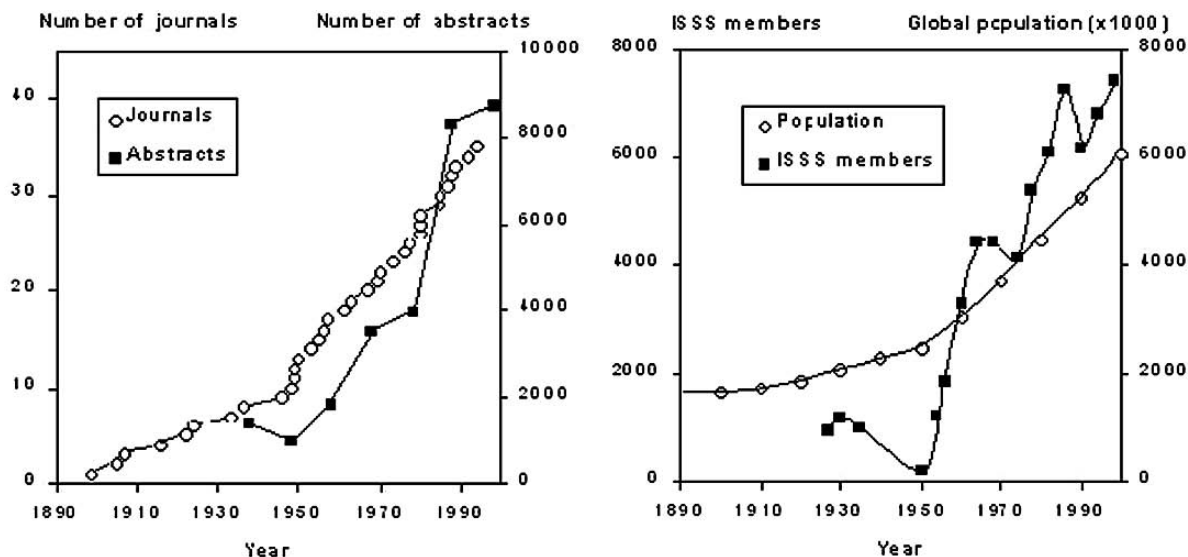

Figure 2. Cumulative number of soil and agricultural journals and number of soil science abstracts in CAB International “Soils and Fertilizers” (graph A), and number of ISSS members and changes in global population (graph B). CABI abstract data from Hartemink (1999), ISSS member data from van Baren et al. (2000) and population data based on reconciliation of published data by the United Nations.

been estimated that the annual increase in soil publications is about 5%. The right-hand side of Figure 2 depicts the increase in world population since the late 1800s and shows that number of journals, abstracts and ISSS members increased more steeply than the global population in the second half of the 20th century. It thus appears that soil science is successful and very productive according to these measures. A recent analysis of papers in the global soil science journal *Geoderma*, revealed that there have been important shifts in soil science since the late 1960s, and much more desk studies are conducted at the expense of laboratory and field studies (Hartemink 2002a).

Population growth estimates

Projections

Since 1950, the world population has grown almost linearly (Figure 3). A linear regression through the 1950 to 2000 data showed that the average increase was 73 million people per year. The regression was highly significant and a high correlation was obtained ($r^2 = 0.994$). Official statistics have shown that the annual increase in human population was 85 million in the late 1980s and had decreased to 80 million per

year in 1995 (Smil 1999). Currently the world population is growing by 1.3% per year, which is significant less than the 2.0% growth rate of the late 1960s. Population growth has been different in different regions. More than 80% of the population lives in developing regions, and Asia accounts for 61% of the world total. Two out of five people in the world live either in China or India. According to the population division of the United Nations, Africa’s population is now larger than that of Europe but in 1960 Africa had less than half of Europe’s population.

Projections for the period 2000 to 2050 are also given in Figure 3. It has been estimated that the world population would be 9.4 billion by 2050. Fischer and Heilig (1997) of the International Institute for Applied Systems Analysis, estimated that the average population increase between now and 2015 is 80 million per year which will decrease to around 50 million per year in 2050. Doubling of the human population by 2050 is therefore unlikely and the UN Department of Social and Economic Affairs has also lowered its forecast to 8.9 billion in 2050 as global population growth is slowing down (Lutz et al. 1997; Smil 1999). About one-third of this drop is due to the unexpectedly dire ravages of AIDS in sub-Saharan Africa and parts of the Indian subcontinent.

Population growth is also slowing down due to a change of attitude in the developing world, which

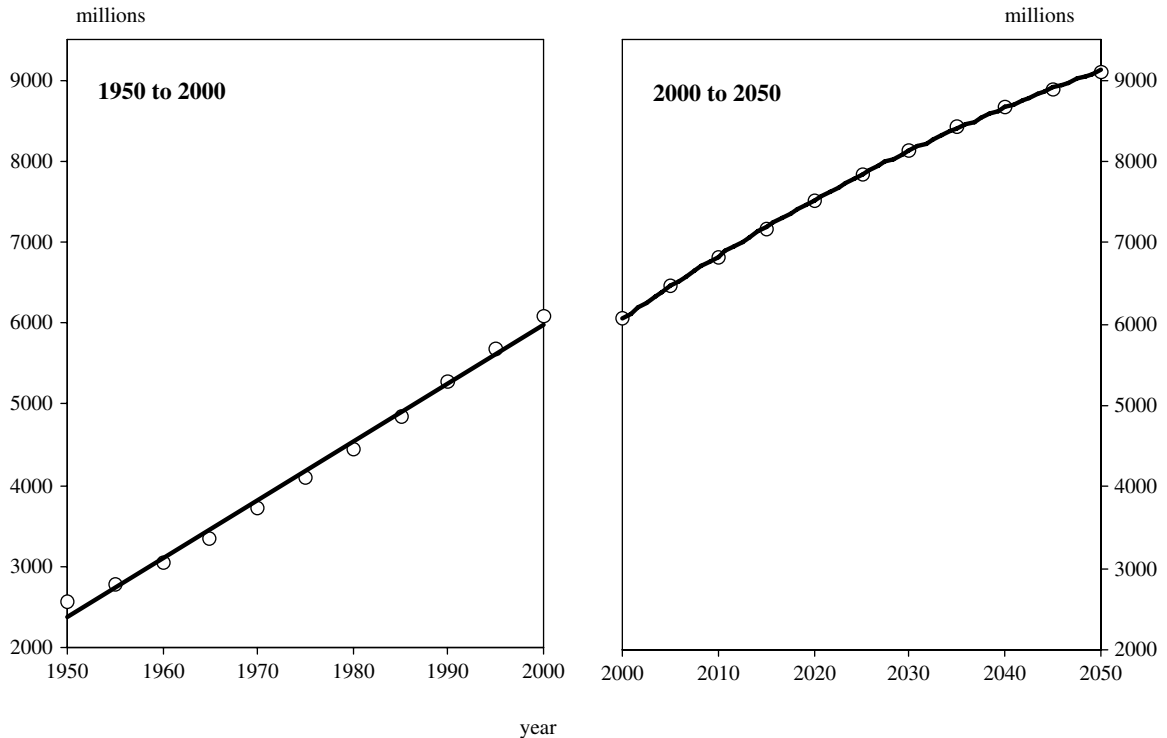

Figure 3. World population estimates for the years 1950 to 2000 and projections for the years 2000 to 2050. Based on reconciliation of published data.

accounts for over 95% of the population growth. In 1969, people in the developing world had an average of six children compared to three today. The population keeps on growing, however, because more babies survive and old people live longer and in Africa each woman has on average five children. By 2050, there will be three times as many people in Africa than in Europe – if AIDS allows it. Of the 34 most AIDS affected countries, 29 are in Africa and life expectancy has been reduced on average by seven years (Anon. 1999). Deaths due to AIDS during 2000 in sub-Saharan Africa was estimated to be about 2.4 million and almost 9% of the adults was infected with HIV/AIDS as opposed to 0.6% in South and South-East Asia (0.47 million deaths in 2000) and 0.2% in Western Europe (7000 deaths in 2000).

Uncertainty

Population forecasts have a mixed record and they are no worse than forecasts by economists, meteorologists and others who have to deal with complex and partially understood systems. However, demographic

projections could point the way for ecological and environmental forecasts which are also bedevilled by uncertainty (Tuljapurkar 1997). Much of the demographic work now focuses on the forecasting of uncertainty, *per se*. A recent report uses a new probabilistic approach that makes use of expert opinion on trends in fertility, mortality and migration and on the 90% uncertainty range of those trends in different parts of the world. It was concluded that the chances for a doubling of the world population by 2050 are less than a third (Lutz et al. 1997). This is based on the expert opinion that human fertility will continue to fall everywhere trailing the decline of mortality by about a half-century (Tuljapurkar 1997).

A new focus of attention is developing in demographic studies and in Western Europe and the USA the focus of the public, political and scientific concern shifts from global population growth to population ageing (Lutz et al. 1997), or as Tuljapurkar (1997) puts it “..for individuals, families and countries everywhere, the largest question of the next few decades will almost surely be, how to age gracefully”. Two hundred years after Malthus’ essay that is quite a shift of focus – at least for those parts of the world where food is ample.

The fear exists that the issue of ageing will detract the much-needed attention from those areas in the world where population keeps on increasing, hunger is widespread and a higher food production is needed to nourish current and future generations. That combination is mostly found in developing countries in tropical regions

Future outlook for food production

The world produces more than enough food at present to feed everyone, but nevertheless many people still starve or are undernourished (Latham 2000). In absolute terms the world already produces enough food to feed ten billion people but the problem is that most of it is fed to animals. It is poverty and not a physical shortage of food that is the primary cause of hunger in the world (Buringh 1982; Latham 2000; Pinstrup-Andersen 1998). Additional problems are inequitable distribution of food supplies, spoilage and other losses between production and consumption, politics (Ross 1999) and war and trading policies. Many international aid programmes aim to alleviate poverty for it is the main cause for hunger and environmental degradation (McCalla 1999). So total global food production is not a good indicator, or as Dudal stated: It is not enough for the world as a whole to have the capability of feeding itself, it is necessary to produce more food where it is needed (Dudal 1982).

Between 1960 and 2000 the world population doubled. But the green revolution during that period brought about substantial increase in food production and quality, these increases resulted from better varieties, improved irrigation and drainage, increased fertiliser use, improved pest and weed control, advances in food storage and transport, increased area under agriculture (Ross 1999). The impact of land degradation on food productivity is largely unknown. In addition there is the loss of land to non-agricultural use which is high (Buringh 1982). There is also limited extra land to take into production (Eswaran et al. 1999; Young 1999) in contrary to predictions made in earlier studies (e.g. Buringh et al. 1975; Meadows et al. 1972).

Prospects for increasing food production depend on improved technologies, a biotechnological revolution, widening of food sources (e.g. sea weed), and more land in production (Ross 1999). Doubling yields in complex and intensive farming systems without damaging the environment is a significant challenge

(McCalla 1999). Progress towards a 'greener agriculture' will come from continued improvements in modern high-yield crop production methods combined with sophisticated use of both inorganic and organic nutrient sources, water, crop germplasm, pest management and beneficial organisms (Sinclair and Cassman 1999).

An important consideration when discussing food production and population growth is undernourishment, which is referred to by FAO as the status of persons whose food intake does not provide enough calories to meet their basic energy requirements (FAO 2000). In 1999, FAO estimated the incidence of undernourishment in the developing countries at some 800 million persons or 18% of the population. It was 960 million in the late 1960s, or 37% of the population (FAO 2000). Projections indicate that it will decrease to 576 million by 2015, and to 401 million by 2030. So both absolutely and relatively the number of undernourished people is on the decline and projections for the future show improvement although hundreds of millions people remain undernourished in the future. Much depends on political resolutions and will-power but if all resources are harnessed, and adequate measures taken to minimise soil degradation, sufficient food to feed the population in 2020 can be produced, and probably sufficient for a few billion more (Greenland et al. 1997).

Discussion and conclusions

Human population grew very fast in the past century and much of this growth occurred in tropical regions. There is no doubt that the concentration of people had environmental implications and in many cases it is likely that the environment has degraded. There are also cases whereby the environment is improved (Tiffen et al. 1994). Various studies in the past predicted gloom: more people, less to eat, scarcity, starvation, misery, war, environmental devastation etc. Obviously, these studies need to be examined against the available information in their times, but it could be argued that the political and emotional content often exceeds the scientific content including the uncertainties in the predictions. But did they help? It is impossible to appraise whether Ehrlich's efforts in predicting gloom have been helping Earth, but we do know now that most of his predictions were wrong. Recent studies have advocated that the widespread environmental problems are grossly exaggerated (Huber 1999; Lomborg 2001).

On the extreme, there are two groups in the world, which either believe that food production and yield increases have reached a plateau (the pessimists) or those who argue that sufficient food can be produced for many billions to come (the optimists). The pessimists, and followers of Malthus, believe that the world is approaching its carrying capacity, that no more cultivable land is available and land degradation is widespread, and that production cannot be sufficiently increased to decrease the 800 million or so who are chronically malnourished (Pinstруп-Andersen 1998). They also believe that socio-economic constraints limit the adoption and spreading of improved cultural practises. The optimists believe that there is room to grow more food by taking new land under cultivation, that the green revolution has not run out of steam and that biotechnology has great potential to feed the growing population. The optimists believe that future generations would produce enough geniuses to solve the problems that more people would cause. Both pessimists and optimists have non-scientific motives in their baggage, and apart from political or emotional motives, they largely base their conclusions on the projections of agricultural production. The wide divergence in these projections can be traced to the different methodological perspectives of ecological and neo-classical economics (Harris and Kennedy 1999).

It can be argued that the preaching of gloom is fruitless unless it is underpinned with science, and is harmful as it encourages fatalism instead of much needed determinism. Given the many unknowns it is fortunate that the discussion on the carrying capacity of the world continues. Like any important subject, the discussion should be based on the collection and careful interpretation of facts and figures in which research plays a major role. Science can provide much needed answers and guide the future focus of the political and research agenda (Greenland et al. 1997). Since agricultural production is largely depending on the soil's productive capacity, soil science should be in the forefront providing the much-needed data on soil resources and scenario studies how soil and land-use changes affect food production. However, it seems that interests of the developed world moves to human ageing instead of population growth. This, in combination with reduced funding for soil research (Mermut and Eswaran 1997), and the inability of the soil science community to clearly demonstrate the importance of soil science (Bouma 2001), is a serious matter of concern.

References

- Anon. 1997. Environmental scare – Plenty of gloom. *The Economist* December 20: 19–21.
- Anon. 1999. Unshapely world, too old or too young. *The Economist* September 25: 60.
- Bennett H.H. 1939. *Soil Conservation*. McGraw-Hill Book Company, Inc: New York & London.
- Bettany G.T. 1890. Introduction. *In: Malthus T.R. by An essay on the principle of population or a view of its past and present effects on human happiness with an inquiry into our prospects respecting the future removal of mitigation of the evils which its occasions* (6th and last edition). Ward, Lock and Co.: London, New York, and Melbourne.
- Boserup E. 1965. The conditions of agricultural growth. The economics of agrarian change under population pressure. Aldine Publishing Company: New York.
- Bouma J. 2001. The new role of soil science in a network society. *Soil Science* 166: 874–879.
- Bouma J., Batjes N.H. and Groot J.J.R. 1998. Exploring land quality effects on world food supply. *Geoderma* 86: 43–59.
- Bouma J. and Hartemink A.E. 2002. Soil science and society in the Dutch context. *Netherlands Journal of Agricultural Science* 50: 133–140.
- Bradfield R. 1960. Opportunities for soil scientists in freeing the world from hunger. *In 7th International Congress of Soil Science*, Madison, Wisconsin, 1960. pp. 1–10.
- Buringh P. 1982. Potentials of world soils for agricultural production. *In 12th International Congress of Soil Science*, New Delhi, 1982. pp. 33–41.
- Buringh P., van Heemst H.D.J. and Staring G.J. 1975. Computation of the absolute maximum food production of the world. Agricultural University, Department of Tropical Soil Science: Wageningen.
- Dudal R. 1982. Land degradation in a world perspective. *Journal of Soil and Water Conservation* 37: 245–249.
- Edelman C.H. 1951. De onuitputtelijke natuur. *Economische-Statistische Berichten*, 12 Sept., 1–4.
- Ehrlich P. 1968. *The population bomb*. Ballantine Book Inc.: New York.
- Eswaran H., Beinroth F.H. and Reich P. 1999. Global land resources and population-supporting capacity. *American Journal of Alternative Agriculture* 14: 129–136.
- FAO 2000. *Agriculture: Towards 2015/30*, Rome.
- Fischer G. and Heilig G.K. 1997. Population momentum and the demand on land and water resources. *In: Greenland D.J., Gregory P.J. and Nye P.H. (Eds) Land resources: on the edge of the Malthusian precipice?* pp. 869–889. The Royal Society: London.
- Gallopin G.C. and Raskin P. 1998. Windows on the future – Global Scenarios and sustainability. *Environment* 40: 7–11.
- Greenland D.J. 1991. The contributions of soil science to society – past, present, and future. *Soil Science* 151: 19–23.
- Greenland D.J. 1994. Soil science and sustainable land management. *In: Syers J.K. and Rimmer D.L. (Eds) Soil science and sustainable land management in the tropics*. pp. 1–5. CAB International: Wallingford.
- Greenland D.J., Gregory P.J. and Nye P.H. 1997. Introduction and conclusions. *In: Greenland D.J., Gregory P.J. and Nye P.H. (Eds) Land resources: on the edge of the Malthusian precipice?* pp. 861–867. The Royal Society: London.

- Greenwood D.J. 1993. The changing scene of British soil science. *Journal of Soil Science* 44: 191–207.
- Hall A.D. 1936. *The improvement of native agriculture in relation to population and public health*. Oxford University Press: London.
- Harris J.M. and Kennedy S. 1999. Carrying capacity in agriculture: global and regional issues. *Ecological Economics* 29: 443–461.
- Hartemink A.E. 1999. Publish or perish (2) How much we write. *Bulletin of the International Union of Soil Sciences* 96: 16–23.
- Hartemink A.E. 2003. *Soil fertility decline in the tropics – with case studies on plantations*. ISRIC-CABI Publishing: Wallingford.
- Hartemink A.E. 2002a. Publishing in soil science – Historical developments and current trends. *International Union of Soil Sciences, Vienna*. p. 196.
- Hartemink A.E. 2002b. Soil science in tropical and temperate regions – Some differences and similarities. *Advances in Agronomy* 77: 269–292.
- Heuvelink G.B.M. and Webster R. 2001. Modelling soil variation: past, present, and future. *Geoderma* 100: 269–301.
- Howard A. 1940. *An agricultural testament*. Oxford University Press: New York and London.
- Huber P. 1999. *Hard green. Saving the environment from the environmentalist. A conservative manifesto*. Basic Books: New York.
- Insam H. 2001. Developments in soil microbiology since the mid 1960s. *Geoderma* 100: 389–402.
- Jacks G.V. and Whyte R.O. 1939. *The rape of the earth – A world survey of soil erosion*. Faber and Faber Ltd: London.
- Jensen N.F. 1978. Limits to growth in world food production. *Science* 201: 317–320.
- Kellogg C.E. 1974. Soil genesis, classification, and cartography: 1924–1974. *Geoderma* 12: 347–362.
- Kendall H.W. and Pimentel D. 1994. Constraints on the expansion of the global food supply. *Ambio* 23: 198–205.
- Lal R. 2001. Managing world soils for food security and environmental quality. *Advances in Agronomy* 74: 155–192.
- Latham J.R. 2000. There's enough food for everyone, but the poor can't afford to buy it. *Nature* 404: 222.
- Lomborg B. 2001. *The skeptical environmentalist: Measuring the real state of the world*. Cambridge University Press: Cambridge.
- Lutz W., Sanderson W. and Scherbov S. 1997. Doubling of world population unlikely. *Nature* 387: 803–805.
- Malthus T.R. 1826. *An essay on the principle of population or a view of its past and present effects on human happiness with an inquiry into our prospects respecting the future removal of mitigation of the evils which its occasions*. Ward, Lock and Co.: London, New York, and Melbourne.
- McCalla A.F. 1999. The challenge of food security in the 21st century. *TAA Newsletter* 19: 12–19.
- Meadows D.H., Meadows D.L., Randers J. and Behrens W.W. 1972. *Limits to growth. A report for the club of Rome's project on the predicament of mankind*. Universe Books: New York.
- Mermut A.R. and Eswaran H. 1997. Opportunities for soil science in a milieu of reduced funds. *Canadian Journal of Soil Science* 77: 1–7.
- Mermut A.R. and Eswaran H. 2001. Some major developments in soil science since the mid-1960s. *Geoderma* 100: 403–426.
- Mohr E.C.J. 1947. De wereldvoedselproductie en de bodem. *Landbouwkundig Tijdschrift* 59: 1–8.
- Nye P.H. and Greenland D.J. 1960. *The soil under shifting cultivation*. Commonwealth Bureau of Soils: Harpenden.
- Osborn F. 1948. *Our plundered planet*. Little, Brown and Company: Boston.
- Penck A. 1928. Das Hauptproblem der physischen Anthropogeographie. *In First International Congress of Soil Science, Washington DC, 1928*. pp 98–116.
- Pendleton R.L. 1954. The place of tropical soils in feeding the world. *Ceiba* 15: 201–222.
- Penning de Vries F.W.T., Rabbinge R. and Groot J.J.R. 1997. Potential and attainable food production and food security in different regions. *In: Greenland D.J., Gregory P.J. and Nye P.H. (Eds). Land resources: on the edge of the Malthusian precipice?* pp 917–928. The Royal Society: London.
- Pinstrup-Andersen P. 1998. Food security and sustainable use of natural resources. *Ecological Economics* 26: 1–10.
- Raats P.A.C. 2001. Developments in soil-water physics since the mid 1960s. *Geoderma* 100: 355–387.
- Ross C. 1999. Can we feed the world in 2020? *New Zealand Soil News* 47: 137–141.
- Russell D.A. and Williams G.G. 1977. History of chemical fertilizer development. *Soil Science Society of America Journal* 41: 260–265.
- Russell E.J. 1954. *World population and world food supplies*. George Allen & Unwin Ltd: London.
- Seidl I. and Tisdell C.A. 1999. Carrying capacity reconsidered: from Malthus' population theory to cultural carrying capacity. *Ecological Economics* 31: 395–408.
- Short R. 1998. An essay on the principle of population, by T.R. Malthus. *Nature* 395: 456–456.
- Sinclair T.R. and Cassman K.G. 1999. Green revolution still too green. *Nature* 398, 556.
- Smil V. 1999. How many billions to go? *Nature* 401: 429.
- Sparks D.L. 2001. Elucidating the fundamental chemistry of soils: past and recent achievements and future frontiers. *Geoderma* 100: 303–319.
- Stamp L.D. 1960. *Our developing world*. Faber and Faber: London.
- Tiffen M., Mortimore M. and Gichuki F. 1994. More people, less erosion. *Environmental recovery in Kenya*. John Wiley & Sons Ltd: Chichester.
- Tinker P.B. 1985. Soil science in a changing world. *Journal of Soil Science* 36: 1–8.
- Tuljapurkar S. 1997. Demography – Taking the measure of uncertainty. *Nature* 387: 760–761.
- van Baren F.A. 1960. Soils in relation to population in tropical regions. *Tijdschrift voor Economische en Sociale Geografie* 51: 230–234.
- van Baren J.H.V., Hartemink A.E. and Tinker P.B. 2000. 75 Years The International Society of Soil Science. *Geoderma* 96: 1–18.
- White J.T. 1941. *Bodemvruchtbaarheid en landsbelang*. Archipel Drukkerij, Buitenzorg.
- Yaalon D.H. and Berkowicz S. 1997. History of soil science – International perspectives. *Catena Verlag, Reiskirchen*. 438 p.
- Young A. 1999. Is there really spare land? A critique of estimates of available cultivable land in developing countries. *Environment, Development and Sustainability* 1: 3–18.

Development of an arable layer: A key concept for better management of infertile tropical savanna soils

Amézquita¹ E., Rao¹ I.M., Hoyos¹ P., Molina¹ D., Chavez¹ L.F. and Bernal² J.H.

¹Tropical Soil Biology and Fertility Institute, International Center for Tropical Agriculture (CIAT), A. A. 6713, Cali, Colombia; ²Grupo Regional Agrícola, Corpoica, C. I. La Libertad, A. A. 3129, Villavicencio, Colombia

Abstract

A concept that is highly relevant for the better management of infertile tropical savanna soils is that of the buildup of an “arable layer”. Before tropical savanna soils can be used for no-tillage systems, the soil’s quality in terms of physical, chemical and biological characteristics need to be improved. The application of this concept will depend on the prevailing soil constraints and current land use, for example, soil compaction and loss of soil structure versus a depletion of soil nutrients and the type of crops to be cultivated. The concept includes tillage practices to overcome physical constraints, an efficient use of amendments and fertilizers to correct chemical constraints and imbalances, and the use of improved tropical forage grasses, green manures and other organic matter inputs such as crop residues, to improve the soil’s “bio-structure” and biological activity. The use of deep-rooting plants in rotational systems to recover water and nutrients from subsoil is also envisaged in this scheme. This concept builds on earlier suggestions for the better management of tropical soils. To be functional, however, more attention needs to be given to the driving forces behind farmer decision-making process and the existing policies for intensifying agriculture on infertile savanna lands.

Key words: arable layer, soil fertility, tropical savanna

Introduction

The Latin American savannas occupy about 250 million ha, or around 50% of the world’s savanna areas. They represent some of the last major frontier available for expanding agricultural production (Borlaug and Dowswell, 1994). The soils of these lands are dominated by Oxisols and Ultisols that characteristically have low fertility (particularly phosphorus (P) and nitrogen (N), high acidity and aluminum (Al) saturation, low organic matter, and poor cation-exchange capacity). Rainfall and temperatures generally favor crop production, although some areas suffer from short-term dry periods during the rainy season that can decrease crop growth.

The level of available P in Oxisols and Ultisols is very low and limit the production of most grain and forage crops. In the Cerrados of Brazil, the physical conditions of the soils are good. The soils are

deep, well drained, and have little presence of rocks and other physical impediments (Kanno *et al.*, 2001). However, the soils of the Colombian Altillanura are relatively shallow, with low rates of water infiltration, and they present problems of superficial sealing (Amézquita *et al.*, 2002; Preciado, 1997; Amézquita, 1998) as shown in Photos 1 and 2 below.

The capacity of water storage and water retention of the soils in the tropical savannas is low, even in the rainy season. The presence of “veránicos” (short dry spells) that are very common during the rainy season in the Cerrados, cause a drastic decline of grain yields (Wolf, 1975). Kanno *et al.* (2001) indicated that to maintain a sustainable production in the Cerrados, it is necessary to develop agricultural systems that facilitate the maintenance or improvement of the physical, chemical and biological conditions of the soil. Research conducted by CIAT in the Llanos resulted in similar conclusions.

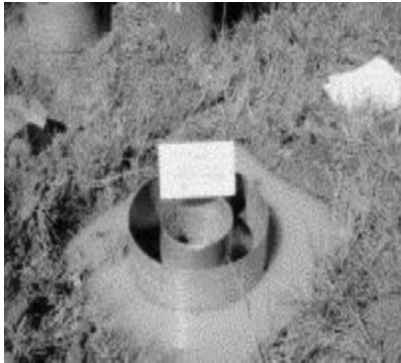

Photo 1. Problem of low rate of water infiltration



Photo 2. Problem of soil compaction



Photo 3. Soil with good aggregation characteristics

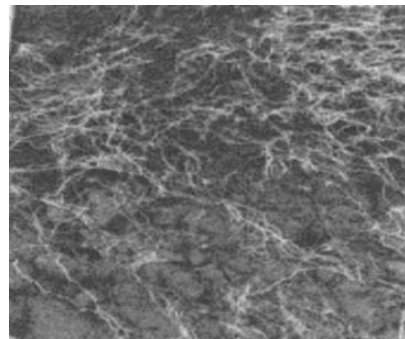

Photo 4. Improved pasture with good root distribution

Soil Quality and Productivity

The quality of the soil can be defined as “the capacity of a specific kind of soil to function, within natural or managed ecosystem boundaries, to sustain plant and animal productivity, maintain or enhance water and air quality, and support human health and habitation (Karlen *et al.*, 1997). The inherent quality of the soil depends on characteristics such as structural attributes, charge density, nutrient reserves, rooting depth, and soil biodiversity (Lal, 1997).

Good soil management should aim to create optimum physical conditions for plant growth and development such as: adequate available water, adequate aeration for roots and microorganisms, ease of root penetration, rapid and uniform seed germination, and resistance of the soil to slaking, surface ceiling and accelerated erosion by wind and water as shown in Photo 3 and 4 (White, 1997). Traditional methods of soil preparation with plow often cause disastrous

results in terms of soil structural deterioration and erosion especially in tropical soils.

A good quality soil permits optimum infiltration due to acceptance and distribution of rainwater across the root zone. It also allows good root penetration by maintaining adequate porosity of (about 50%) with proper pore size (macro, meso and micropores) distribution. These soil physical conditions favor adequate soil moisture and aeration to permit root growth and distribution across the soil profile. It also should contain adequate levels of all the essential nutrients (macro- and microelements) in available form and with good capacity for replenishment. It should also possess medium to high level of organic matter to facilitate better soil aggregation and nutrient supply to plants. The challenge is to maintain or conserve these optimum soil conditions to sustain high level of agricultural productivity over long term.

A poor quality soil impedes infiltration and redistribution of water. It may have good porosity but poor distribution of soil pores thus impeding the development of roots. Because of low availability of some key nutrients such as N and P and the imbalance of

some other essential elements, it cannot provide adequate supply of the essential nutrients in the form and at the time when the plant requires them. Usually it contains low amounts of organic matter and it is difficult to manage and very susceptible to degradation.

Agricultural sustainability implies that agriculture will remain with the principal land use over long periods of time relative to human lifespan, because it is economically competitive and the resource base will not decline in extent, fertility or health (quality) (Hamblin, 1991). The degradation of the soil refers to temporary or permanent changes to the conditions of the soil leading to the decline of crop yields. The decline in crop yields could contribute to both poverty and natural resource degradation.

Relatively few cultivated areas in the world present soils of good natural quality for agriculture. With the need for obtaining high yields, humans have improved the natural fertility of the soil thereby crops with high yield potential and nutritional requirements can produce economically viable yields. One of the biggest challenges for agriculture in the tropics is the vulnerability of tropical soils to the degradation when they are subjected to mechanization for crop production. In the Colombian Llanos, farmers have to abandon the lands after 4 to 7 years of continuous cultivation of upland rice because the soil quality degrades and it is no longer capable to support economic yields.

Investigations carried out in the Llanos of Colombia (Amézquita *et al.*, 1998) have demonstrated that the physical, chemical and biological conditions of the soils of the native savannas don't offer proper environment for adequate root growth and crop yield. These soils are also very susceptible to degradation due to the vulnerability of their structure when they are subjected to cultivation. The use of tillage implements (disc harrow) causes not only superficial sealing but also



Photo 5. Cultivation on native savanna with a disc harrow



Photo 6. Soil erosion and ceiling caused

reduction in water infiltration thus affecting rainwater acceptance as shown in Photos 5 and 6. Thus to sustain the productivity of crop-livestock systems, these soils will require proper diagnosis of soil constraints and management strategies to minimize degradation.

Soil constraints in the Colombian Llanos

The Colombian Altillanura soils present the following physical, chemical and biological constraints for agricultural production. The physical constraints are relatively shallow depth (susceptible to erosion), weak structure, low rates of water infiltration, low aeration capacity, high resistance to penetrability, prone to surface sealing, retain less soil moisture, and contain low levels of organic matter. The main chemical constraints are low availability of essential nutrients, particularly P and N, toxicity of aluminum (Al) throughout the soil profile thus impeding the development of root systems of both crops and pastures. Because of these major physical and chemical constraints, in general the biological activity (rate of N mineralization, density of microorganisms, number and biomass of macrofauna) of these soils is very low.

Need for building up of an “arable layer”

Grain yields of acid soil adapted upland rice and maize planted on newly opened savannas are lower than those obtained from long-term legume-based introduced pastures with similar amounts of fertilizer input (Sanz *et al.*, 1999). This indicated that soil improvement occurred under long-term pasture conditions that contributed to greater grain yields. Therefore we adopted the concept of building up an arable layer

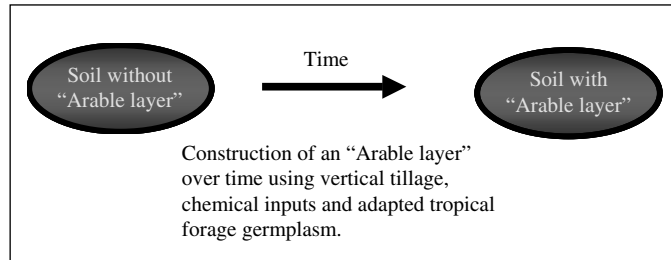

Figure 1. The construction of an “Arable layer” over time using vertical tillage, chemical inputs and adapted tropical forage germplasm.

to improve soil quality, to raise crop-livestock productivity over time and to minimize environmental degradation.

Developing an arable layer requires use of vertical tillage (chisels) to overcome the physical constraints, application of small amounts of lime and fertilizers to overcome the chemical constraints and use of acid soil adapted tropical forage germplasm to improve soil organic matter content and biological activity. Use of vertical tillage and application of lime and fertilizer facilitate rapid growth and turnover of the vigorous root systems of tropical forage grasses (*Brachiaria* and *Panicum*) and contribute to marked improvements in quality of topsoil (Amézquita *et al.*, 1998).

Development of a productive topsoil or “arable layer” involves two stages: first, the physical, chemical and biological constraints of the soil need to be

diagnosed; second, soil and crop management practices need to be optimized to overcome the major soil constraints. We believe that the development of an “arable layer” is a prerequisite for systems of direct planting that can be implemented after improving soil quality. Without developing an arable layer, it may be difficult to develop economically viable, agriculturally sustainable and ecologically acceptable crop-livestock systems for the Llanos Orientales in a near future.

Figure 1 illustrates the necessary steps to construct an “arable layer” and to develop sustainable agriculture.

Construction of an “arable layer”

In practice, construction of an arable layer involves the following procedures (Figure 2):

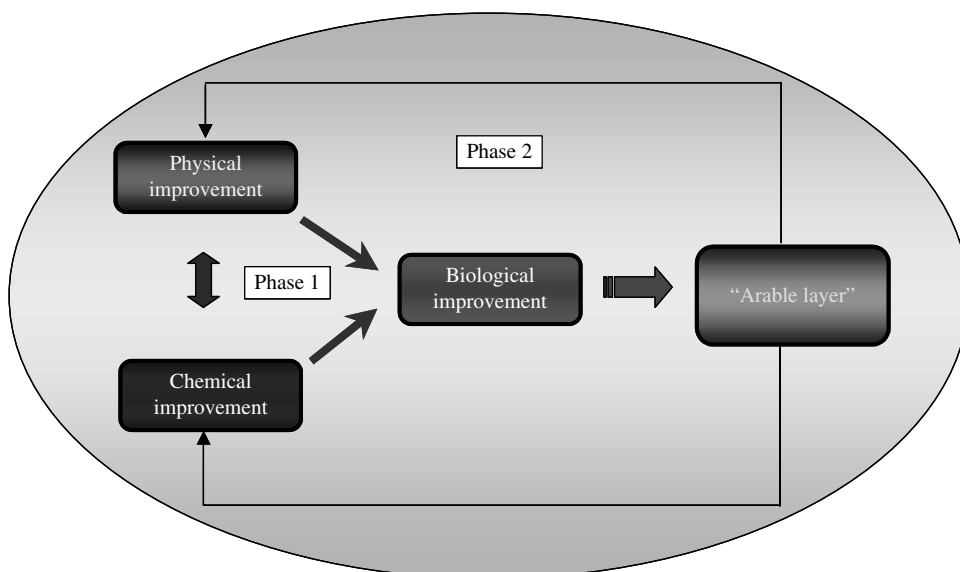

Figure 2. Physical and chemical improvement combined with biological improvement leads to the formation of an “arable layer”.

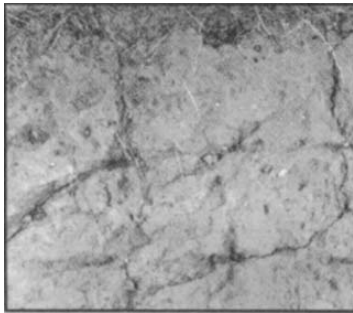

Photo 7. Effect of vertical tillage



Photo 8. Rooting depth of tropical forages

Phase 1

- *Physical improvement of the soil.* In acid infertile soils (Altillanura), the use of vertical tillage with rigid chisels permit a good breaking up of the soil up to a depth of no more than 30 cm (Photo 7). The soil becomes loosened with the use of chisel and this effect (loosening) improves several of its properties: water infiltration, capacity of aeration, distribution of nutrients, and rooting depth for tropical grasses and legumes (Photo 8).
- *Chemical improvement of the soil.* Before passing the rigid chisels, depending on native fertility and Al saturation and on local availability the following inputs may be considered for application to improve availability of Ca, Mg, S and P: lime, sulcamag, dolomite, rock phosphate or calfos. These inputs are incorporated into the soil using rigid (parabolic) chisels.

Phase 2

- *Biological improvement of the soil.* Genetically adapted tropical forage grasses or grasses and legumes need to be planted to introduce abundant fibrous roots across soil profile of the prepared and fertilized soil.

Conclusions

The development of an “arable layer” described here shows the interdependence of the biotic and abiotic components of the soil and it promotes their mutual interaction.

- The use of vertical tillage and fertilizer inputs favors the abundant and vigorous root growth of tropical forages thereby improving soil organic matter and recycling of nutrients via aboveground litter and turnover of roots (Phase 1).
- As the topsoil quality improves through the construction of an arable layer, it becomes more suitable for direct sowing of commercial crops that have high demand for nutrients (Phase 2).

We believe that this concept of building an arable layer is relevant to improve food security and environmental sustainability in the tropics, particularly on infertile soils. However, it is important to note that for the “arable layer” concept to be functional, more attention needs to be given to the driving forces behind farmer decision-making and the existing policies for intensifying agriculture on infertile savanna lands.

References

- Amézquita E. 1998. Propiedades físicas de los suelos de los Llanos Orientales y sus requerimientos de labranza. *In:* Gabriel Romero C., Diego Aristizábal Q. y César A. Jaramillo S. (eds). MEMORIAS “Encuentro Nacional de Conservación”, Villavicencio, 28-30 de Abril de 1998. pp. 145–174.
- Amézquita E., Preciado G., Arias D.M., Thomas R.J., Friesen D.K. and Sanz J.I. 1998. Soil physical characteristics under different land use systems and duration on the Colombian savannas. 16th World Congress of Soil Science. Montpellier, France (poster presentation).
- Amézquita E., Chávez L.F. and Bernal J.H. 2002. Construcción de una “capa arable” en suelos pobres: conceptos esenciales aplicados en la Altillanura. Folleto con la participación de COLCIENCIAS, CIAT y CORPOICA.
- Borlaug N.E. and Doswell C.R. 1994. Feeding a human population that increasingly crowds a fragile planet. Keynote address at the 15th World Congress of Soil Science. Acapulco, México. Suppl. 1–15.
- Hamblin A.P. 1991. Sustainable Agricultural Systems: what are the appropriate measures for soil structure? *Aust. J. Soil Res.* 29: 709–715.
- Kanno T., Macedo M.C.M., Uozumi S., Euclides V.P.B., Bono J.A., Yoshimura Y., Correa M.R. and Santos Jr. J.D.G. 2001. Development of grassland management technology for sustainable agropastoral systems in the sub-tropical zone in Brazil. *In:* Kanno, T. and Macedo M.C.M. (eds). JIRCAS/EMBRAPA Gado de Corte. International Joint Workshop on Agropastoral System

- in South America. JIRCAS Working Report No.19, January 2001. pp.63–73.
- Karlen, D.L., Mausbach M.J., Doran J.W., Cline R.G., Harris R.F. and Schuman G.E. 1997. Soil Quality: A concept, definition and framework for evaluation. *Soil Sci.Soc. Am. J.* 61: 4-10.
- Lal R. 1997. Soil quality and sustainability. pp. 17–30. *In: Lal R., Blum W.H., Valentine C. and Stewart B.A. (eds). Methods for Assessment of Soil Degradation. Advances in Soil Science. CRC. Boca Raton, N.Y.*
- Preciado Pérez L.G. 1997. Influencia del tiempo de uso del suelo en las propiedades físicas en la productividad y sostenibilidad del cultivo de arroz en Casanare. Tesis M.Sc., Escuela de Posgrados, Universidad Nacional de Colombia, Palmira. 131 pp.
- Sanz J.I., Zeigler R.S., Sarkarung S., Molina D.L. and Rivera M. 1999. Sistemas mejoradas arroz-pasturas para sabana nativa y pasturas degradadas en suelos acidos de América del Sur. pp. 232–244. *In: Guimaraes E.P., Sanz J.I., Rao I.M., Amézquita M.C. and Amézquita E. (ed). Sistemas agropastoriles en sabanas tropicales de America Latina. CIAT, Cali, Colombia & EMBRAPA, Brasilia, Brazil.*
- White R.E. 1997. Principles and practice of soil science. The soil as a natural resource. Blackwell Science, United Kingdom. 3rd Edition. pp. 348.
- Wolf J.M. 1975. Soil-water relations in Oxisols of Puerto Rico and Brazil. *In: Bornemisza E. and Alvarado A. (eds). Soil Management in Tropical America. Raleigh, NCSU. pp. 145–154.*

Food Security in Africa: The Challenges of Researchers in the 21st Century.

James B. Kung'u

Department of Environmental Science, Kenyatta University, P.O. Box 43844 Nairobi, Kenya. Email: kungu_james@yahoo.com

Abstract

Food production in most of Sub-Saharan Africa (SSA) has not kept pace with the population increase over the past three decades. In many countries, food security remains a serious problem. It contributes both to high rates of under- and malnutrition, poorer learning in school, and lack of development in general. In Africa as a whole, food consumption exceeded domestic production by 50% in the mid-1980s and more than 30% in the mid-1990s. Food aid constitutes a major proportion of net food trade and in many countries it constitutes more than half of net imports. Despite food imports, per capita dietary energy supply (DES) remains relatively low; with about one-third of the countries having per capita DES of less than 2,000 kcal day⁻¹ which is lower than the minimum recommended intake.

Food imports to Sub-Saharan Africa rose from US\$ 1.1 billion in 1970 to US\$5.3 billion in 1985 contributing to increased external debt from US\$5.4 billion to US\$58.8 billion during the same period. In 1998, external debt stood at US\$230 billion. Since the 1980's global recession and introduction of Structural Adjustment Programs (SAPs), Africa's debt burden has grown from 30% of GNP to over 100% at present

Agriculture in Africa is not only a vital source of food but also the prevailing way of life. An average of 70% of the population lives by farming, and 40% of all exports are earned from agricultural products. One-third of the national income in Africa is generated by agriculture. Crop production and livestock husbandry account for about half of household income. The poorest members of society are those who are most dependent on agriculture for jobs and income. On average, the poor in SSA spend 60-80% of their total income on food.

Agricultural and economic growth must rise in Africa to realise basic development goals in the 21st century. Only a few countries are currently recording a positive growth in agricultural production while the majority of countries are seeing an increase in the area under agriculture. One consequence of the growth in agricultural area could be a doubling by the year 2050 of cultivated land area which will be great cost to the natural environment unless there is greater investment in agricultural management and technology on existing cropland. The scale of food imports in Africa has fostered dependence on food production in the rest of the world. Many Sub-Saharan African countries face the risk that supplies will fluctuate drastically with the rise and fall of grain reserves and prices on international markets. This paper tries to identify major challenges the African scientists must overcome in order for the African farmers to increase their agricultural production and achieve food security and sustainable economic growth in the 21st century.

Key words: Food security, land degradation, Research

Introduction

The number of hungry people in Sub-Saharan Africa (SSA) is reported to be increasing. Food security

is one of the most complex political, economic and moral problems of our times. Yet, food security in a nation is one of the most important indicators of development, particularly in low-income countries

(FAO/WHO, 1992). There can be no development without the creation of sustainable and regenerative food systems for all people. Despite the concerted efforts of governments and non-governmental organisations (NGOs), many countries are faced with food security crisis which arises from growing inequality in the distribution of resources, food and income. The situation is further aggravated by accelerating population growth, severe drought and intensification of commercial market-oriented agriculture, which is accompanied by monetization of rural economies. The threats of famine, mass starvation, civil strife and poverty are looming and persistent in most countries. Many governments are unable to provide for the needed infrastructure, better marketing and storage facilities and/or agricultural policies that could encourage subsistence production. Farmers are overwhelmed by unfavourable conditions and many households are unable to afford food. Hence, food security is a continuing challenge. There are about 800 million hungry people in the world today. Out of these, 232 million (29%) are found in India, 200 million (25%) in SSA, 152 million (19%) in Latin America, 112 million (14%) in Asia other than India, 56 million (7%) in the Caribbean and 40 million (5%) in the Near East and North Africa.

Africa has gone from being a key exporter of agricultural commodities into being a net importer, and is currently receiving most food aid, with some 30 million people requiring emergency food aid in any one year. Sixty per cent of the World Food Program's work now takes place in Africa. Despite food imports, per capita dietary energy supply (DES) remains relatively low with about one-third of the countries having per capita DES of less than 2,000 kcal day⁻¹ in the 1990s which is lower than the minimum recommended intake. Agricultural and economic growth must rise by 4% yr⁻¹ to realise basic development goals. One consequence of agricultural growth could be a doubling by the year 2050 of cultivated land area at great cost to the natural environment unless there is greater investment in agricultural management and technology on existing cropland (Anon., 1999). The scale of food imports has fostered dependence on food production in the rest of the world. Africa faces the risk that supplies will fluctuate drastically with the rise and fall of grain reserves and prices on international markets.

In SSA measures to secure a stable and sustainable flow of food supply, at affordable prices, are imperative for preventing malnutrition, famine and food insecurity. Government interventions in food markets, especially those that are triggered by the instability inherent

in food production and prices, are common in practically all countries. All too often, however, the design and analysis of these measures focus narrowly on the financial-budgetary aspects of the neglect of several other food security aspects that are equally essential for their successful implementation.

The big question is how scientists in Africa can ensure that every citizen in the continent enjoys access to adequate nutritious food. This paper draws attention to the role scientists can play on food security and point out some strategies for food security related research.

Role of agriculture in Africa

Agriculture is not only a vital source of food in Africa; it is also the prevailing way of life. An average of 70% of the population lives by farming, and 40% of all exports are earned from agricultural products (WRI, 1996). One-third of the national income in Africa is generated by agriculture. Crop production and live-stock husbandry account for about half of household income. On average, the poor from developing countries of SSA spend 60-80% of their total income on food (WRI, 1998). Although industry is significant in a few countries, it is still in an early stage of development. In many countries, the level of mechanisation, including irrigation, processing, and storage facilities, is particularly low. Population pressure has been seen as a cause of world hunger, which is hardly the case although it is an aggravating factor. Climatic conditions and change have also been convenient scapegoats, yet an abundance of food can and does exist alongside famine even in natural hazards.

Africa is facing declining per capita agricultural output. Food imports to SSA rose from US\$ 1.1 billion in 1970 to US\$ 5.3 billion in 1985 contributing to increased external debt from US\$5.4 billion to US\$58.8 billion during the same period. In 1998, external debt stood at US\$230 billion. Since the 1980's global recession and introduction of Structural Adjustment Programs (SAPs), Africa's debt burden has grown from 30% to over 100% of GNP. The links between international/national economic policies and the natural resource base of implementing countries have not sufficiently been made in past policy formulation.

Africa is facing declining per capita agricultural output (Delgado and Mellor, 1984). As demand for food increases, so does demand for land. This has led to declining fallow periods and increased mono cropping

(ICHI, 1986). Pastoral livestock agriculture has suffered from a combination of denuded range lands and pressure from agriculture as marginal lands come under cultivation (Dixon et al., 1989). All these factors have contributed to food insecurity.

Agriculture employs a greater share of the labor force than in any other region (apart from East Asia and the Pacific). Over 96% of farmers operate on a small-scale, farming less than five hectares. The sector is, however, characterized by weak linkages to markets and little or no access to external inputs. Many small-scale farmers farm degraded land and most are far from services and roads and consequently from extension programs.

Food security in Africa

The 1975 UN definition of food security reflected the thinking of the day, which focused on adequate production at the global and national level. This was also a conventional view of food as a primary need. Food security is, however, a matter of both limited food availability and restricted access to food. Food insecurity is no longer seen simply as a failure of agriculture to produce sufficient food at the national level, but instead as a failure of livelihoods to guarantee access to sufficient food at the household level. Today, most common definitions begin with individual entitlement, though recognizing the complex inter-linkages between the individual, the household, the community, the nation and the international community. In the 1996 Rome Declaration on World Food Security, food security is defined as:

Food that is available at all times, to which all persons have means of access, that is nutritionally adequate in terms of quantity, quality and variety, and is acceptable within the given culture (World Food Summit, 2002)

As mentioned above availability, access and affordability are all elements of food security. These are complex issues that encompass a wide range of interrelated economic, social and political factors both internal and external. All these factors challenge Africa's ability to address food security. Analysts generally believe that Africa's current food emergencies are the result of a combination of problems that range from drought and adverse weather patterns and civil conflict, to political-economic crises, HIV/AIDS and poor policy decisions. What is undeniable is that "Africa's persistent vulnerability is arguably due as much to a failure of understanding as to a failure of interventions". High-quality land

resources per household have shrunk in Africa over the past two decades, often dramatically.

Current scenario of the food security situation in Africa

No human right has been so frequently and spectacularly violated in recent times as the right to food, despite the fact that it is one of the most consistently enshrined rights in international human rights law and constantly reaffirmed by governments. Concerns generated by the food crisis of the mid-1970s led to world leaders accepting the common responsibility of the international community to abolish hunger and malnutrition. Targets set by the World Food Summit in 1996 for the reduction of hunger have largely failed, despite food production having grown faster than world population. Global, national and human security issues are increasingly converging, and in some regions overlapping.

Throughout the 1970s, the population in SSA expanded more rapidly than food production. The estimated number of people who were undernourished increased from 60 million in 1969/1970 to nearly 80 million by the end of the decade. Africa's nutrition situation became worse in the early 1980s with the onset of severe droughts and reduced food production. At the height of the crisis, the undernourished population rose to 100 million people. Sub-Saharan Africa is projected to have a per capita food supply of 2,170 calories per-day, which is the lowest among all regions by 2010. In contrast, the industrialised countries are projected to have a per capita food supply of 3,470 calories per day (Hazell, 1995). International Food Policy Research Institute's (IFPRI) model, which projects ahead to the year 2020, also envisages little improvement in food security in SSA, even under a variety of alternative projections of growth, investment, and trade liberalisation (Hazell, 1995).

The World Bank projects that developing countries will be importing about 15 percent of their grain consumption by 2010. FAO estimates that net imports by developing countries may increase from 90 million metric tons in 1988–90 to about 160 million metric tons by 2010. Most of the imports are said to be wheat and coarse grains (World Resources Institute, 1996).

Worldwide the trends on food security are alarming as progress in reducing hunger in the developing world has slowed to a crawl and in most regions the

number of undernourished people is actually growing, despite the fact that world food production has grown faster than world population in the past three decades. The latest estimates indicate that some 840 million people were undernourished in 1998–2000—11 million in the industrialized countries, 30 million in countries in transition, and 799 million in the developing world. The consequences of worldwide hunger are only now being appreciated. At the 2002 World Food Summit (WFS) the chairperson stated: “Together with terrorism, hunger is one of the greatest problems the international community is facing” (World Food Summit, 2002).

The reasons why action plans to address food security have continued to fail in Africa can be attributed to faulty problems analysis leading to faulty research actions. What is needed is an understanding that goes beyond conventional, orthodox wisdom to work more strategically in developing and implementing effective, national and regional research policies. Availability, access and affordability are all elements of food security

Major causes of food insecurity in Africa

Land degradation

Regular droughts are a fundamental part of the climate in Africa where there is normally an exceptionally high variability in rainfall and temperatures. Environmental factors impact heavily on agriculture, and agriculture in turn has a substantial impact on the environment. There are increasing reports of land degradation, deforestation, water logging and salinisation contributing to the declining ability of Africa to feed itself. Lesotho is a good example. Agriculture in this small country faces a catastrophic future, with average farm yields having declined by more than two-thirds since the 1970s. Soil erosion is spreading fast, and soil fertility is deteriorating even further. During the last months of 2002, it was reported that Lesotho experienced unseasonal weather conditions in the form of frost, cyclones and hail. While the issue of food security is directly linked to climate change and variability, weather is not the single determinant of yield, nor is the physical environment the only decisive factor in shaping food security. Scientists in Africa must come up with ways and means of overcoming climate related problems.

Fallow periods have declined, in all but some land rich countries in south-central Africa (Binswanger and Pingali, 1988), as African agriculture pushes into, and meets the land frontier. Population and other factors have put considerable pressure on land resources. Farmers have tended to survive by adopting extensification measures (by bringing pastoral or forested lands under cultivation) instead of sustainably intensifying by employing a higher level of labor and capital intensive techniques.

In SSA, soil mining is coupled with low agricultural yields. FAO data (FAO, 1986) indicate that the average yield for sorghum in Niger is 300 kg ha⁻¹ compared to 4000 kg ha⁻¹ in the US. In Sudan maize yields are 800 kg ha⁻¹ while the US is able to produce 7,500 kg ha⁻¹. While these comparisons arise out of diverse farming systems and varied ecological and economic conditions that exist between North America and Africa, they display the relative inefficiency of African agriculture, and may be indicative of a landscape with an inherent potential for degradation.

Ahmed et al. (2000) reported that higher yield for improved varieties of dryland crops, sorghum and millet, can only be realized when complimented with fertilizer use and improved irrigation. They reported that use of these complimentary inputs have been the exception in Africa and not the rule, thus yields are below potential. Low crop yields in SSA are forcing the region to continue importing large quantities of grain.

An endogenous factor affecting production is the poor quality of soil. African soils are relatively nutrient deficient and prone to degradation because they are geologically mature and highly weathered. The Green Revolution of the mid-1960s in Asia occurred because of the use of improved varieties and often with irrigation on fertile land. In comparison most African soils are marginal uplands. Improving yields on marginal uplands requires appropriate resource management strategies (Lal, 1990).

In Africa little research and development on food crops to improve low yields in drylands is occurring. Research funds tend to favor crops that are consumed outside the region. The implication for drylands is lack of improved yields in millet and sorghum, which are staples in 13, mostly dryland countries, with a population of 200 million. There has been no significant breakthrough in the genetic improvement of rainfed crops like millet and sorghum, which are grown in low rainfall areas, including 80% of the cultivated land in the Sahel (World Bank, 1984).

Most of the populations living in SSA are poor and lack sufficient housing, infrastructure and services that can mitigate the impact of a disaster. Some live in flood-prone or geologically unstable areas or they farm marginal lands. Demographic changes, environmental degradation, changes of river, dam and land management and other factors increase vulnerability. Susceptibility to natural hazards aggravate the adverse effects of these natural events, particularly in the least developed and conflict-ridden countries.

Lack of resources

There is a perception that Africa has under performed in macro-economic terms, but in fact according to World Bank statistics, Africa has not lagged behind the world as a whole: its growth rate in the period 1990–96 was 2.1% as against Latin America's 2.5%, East Asia's 4.0%, South Asia's 3.0%, and 0.8% for high income economies. Food production has in fact increased by over 25% in the last two decades, but not fast enough in terms of per capita production. Some countries in SSA has been having a negative per capita GDP growth rate of -1.0% between 1975 and 1999, compared with 6.0% for East Asia and the Pacific and 2.3% for South Asia.

Food insecurity and hunger are closely related to poverty and an inability to purchase food. Tackling hunger cannot be solved by simply producing more food for famines have occurred even with plenty of food. Most people buy food rather than produce it and in fact very few people, including small-scale farmers are entirely self-sufficient in food production. It has been reported that as harvests fails, people resort to selling of their livestock and assets to finance food purchases leading to higher food prices and lower livestock prices.

Security of land tenure is not only a determinant of food production for land is an essential resource for many people if they are to escape poverty, but it also influences conservation of that particular land. Traditional, political, social, and legal factors have been responsible for unequal access to land in Africa. This, in turn has increased the risk of resource degradation. Lack of security in land tenure in many African societies has reduced the motivation to invest in conservation of resources leading to further land degradation and low agriculture productivity. The distribution of land especially the eastern and southern Africa is so unequal that land reform and land redistribution is essential if there is to be a major reduction in poverty.

Land reform programs have enormous potential to increase agricultural production especially if they can be accompanied by comprehensive programs of access to credit, savings and markets. There is need for scientists in Africa to carry out more studies on land distribution and come out with research findings that can influence land policies on the continent.

Public investment in African agriculture has been falling for many years. Aid to agriculture and rural development in the late 1970s accounted for more than a third of total aid. In the late 1980s, that figure dropped to 24%. It is now closer to 10%. World Bank lending has fallen from around 31% of its total lending in 1979–81 to less than 10% in 1999–2000 (World Bank, 2000). Poverty strategies of many African countries make little mention of agricultural and rural development as sources of poverty reduction. No wonder, many African government budgets for agriculture have declined.

African scientists should not ignore traditional crops (which are more drought-resistant e.g. root crops, millet and sorghum) at the expense of cash crops. In Africa, small-holder agriculture has proved to be at least as efficient as large farms when farmers receive similar support services in inputs like seeds, fertilizer and credit. An FAO study revealed that small farms tend to be more productive and offer more employment to surrounding populations than large estates (reference). The International Food Policy Research Institute (IFPRI, 2001) estimated that for 1% rise in agricultural productivity, poverty would be reduced by 0.6%. The African countries must have additional public investment into on-farm improvements such as irrigation, better seeds, conservation of the natural-resource base for food production, improvement in research and extension collaboration, upgrading of rural infrastructure and improved market access.

New challenges and opportunities

Most recent attempts to develop hypothetical models of the world's potential to increase food production over the next decades conclude that the potential is sufficient to meet the growth of effective demand as world population and incomes increases. However, there is a substantial gap between the world's hypothetical production potential and short-term realities in certain regions, particularly in SSA (IFPRI, 1995)

In this millennium, food and agricultural production have to be promoted with viable livelihoods and improved human well-being, while at the same time

ensuring enhanced natural resources and environment at the local, national, and global levels. The fundamental challenge facing scientists in Africa in the 21st Century is to assist African farmers in increasing their food production in a sustainable way to be able to feed the expanding populations. Such an increase has to come primarily through the intensification of current agricultural production, as potential for bringing new land under cultivation in most countries is very limited. If hunger and poverty are to be reduced, this agricultural intensification must be both ecologically, socially, and economically sustainable.

New challenges and opportunities in Africa must be recognized and incorporated in research and development. Success will depend on the effective functioning of the whole continuum of actors and processes, including research, technology, infrastructure, good governance and policies on marketing and extension, combined with commitment to the plight of the Africans. The weakest link will determine the impact of the entire system; hence, it is imperative that all researchers must encourage all partners to play their effective and efficient role.

Sub-Saharan Africa's share of the world's food insecurity is projected to rise to nearly 40 percent of the total SSA population by 2010. At that time, every third person in the region is likely to be food insecure, with some 300 million people chronically undernourished.

The ability of researchers in Africa to incorporate all the scientific and technological capacity necessary to create performing varieties is very important. The involvement of stakeholders holds the key for the success of solving food insecurity in Africa. There is a need for focusing agriculture research on a number of indigenous plant species / or on traits of interest of high economic importance. Researchers in Africa must play a major role in exploiting the rich biodiversity in the continent for the benefit of the continent. Partnerships must be developed with entities that are capable of solving the problems in the continent. The researchers must accept the role of biotechnology in solving some of the continent food related problems but must patent plants and genes for the benefit of the African people.

Research approach:

The various challenges to sustainable management of natural resources for agricultural development, including water scarcity, soil degradation, biodiversity conservation are largely eco-regional in nature

and require eco-regional solutions. An eco-regional research approach will require increased collaboration within regions and a stronger emphasis on incorporating indigenous and farmer knowledge and innovation systems. While there is a need to concentrate on national researches that have international dimensions, it is important to compare notes with other researchers in a particular region. While carrying out research to solve the problems of food insecurity, the researchers must ensure the following: Efficiency, relevance, and collaboration

Food safety and the environment have to become topics of major importance for research in Africa. Researchers must have a considerable amount of research that focuses on finding solutions to protect the environment and human welfare from the negative fallout of agricultural practices. Another major area of research should be on policy, with concerns such as how to make the best use of the water available and what incentives might lead to a sustainable use of resources. These aspects should be particularly noticeable in countries in Sub-Sahara Africa.

Food security, sustainability and poverty alleviation can only be achieved if appropriate policies and investments are in place. From the farm level to the national level, many policies affect food production systems, including trade and macroeconomic policies, water management and allocation, property rights, agricultural input and output markets, and rural infrastructure and financial markets. Policy research should remain an important part of research strategies in the coming decades.

In response to new scientific developments that cannot be categorized within traditional sectors, collaborative research needs to be encouraged. Certain new research techniques can be used for many different purposes; for example, geographical information systems (GIS) can be applied in agricultural research as well as in rural or transport planning. The same is true of molecular biology, which has many biological, medical, and agricultural applications. The interest in collaborative research can be explained as a function of the need to combine new specialization. Because of the high costs involved, many research institutes in Africa cannot maintain all of the new specialization available. There is therefore a need for scientists to seek alliances through collaborative projects.

For Africa to develop and be self-sufficient in food production, mechanisms, programs or institutes need to be established to carry out combined research, which interact with the agro-industrial sector and

the producers. The collaborative mechanisms should emphasize the joint generation of knowledge and new technologies (Rutten, 1999).

Focus on basic research in universities

Traditionally universities in Africa have played a major role in agricultural research and their participation in public agricultural research need to grow more. This is because universities have greater flexibility in adapting their research agendas than research institutions, and they are more concerned with basic research, which continues to be considered as a public responsibility.

Concern has been expressed on many occasions about the low impact of the scientific system on societal development. Basic research in agriculture can lead to the following benefits:

- new information;
- new instruments and technologies;
- skills among researchers and especially among post-graduate students who later move on to other activities;
- access to information and networks of experts;
- ability to resolve complex technological problems;
- creation of new companies based on new discoveries.

This list shows that technological results form only a small part of research benefits and that, to obtain maximum benefits, it can be useful to have a link with the university environment (Persley, 1998).

To ensure more appropriate responses to the new research demands and new financial mechanisms, there has to be an attempt to make use of human resources more creatively. This can most commonly be achieved through short-term contracts, for example, for Ph.D. projects. Though the effect is ambiguous, however, on the one hand, there is greater mobility of researchers between professions, and a wider diffusion of knowledge, which leads to the creation of a broader knowledge cloud. Short-term contracts provide organizations with a mechanism to select the best researchers from the temporary personnel. On the other hand, reduced employment security limits the possibilities to carry out long-term research.

There is a need for integrating research findings into education systems if problems of food security are to be solved in SSA. Such integration has always been strong in many developed countries. Not only does integration of research into the education system

lead to budget cuts, but it also reflects the importance attached to knowledge and the concern to ensure adequate diffusion of research results. In addition, the use of scientists who also have educational responsibilities leads to greater flexibility and facilitates the development of a critical mass. Another element that needs to be done is to integrate nonagricultural disciplines into agricultural research.

Co-financing modalities

Co-financing between producers and governments in Africa need to be encouraged. Researchers in Africa should establish a co-financing formula where the producers decide what research is of interest to them, and pay for it. In situations where the technological impacts of research are barely noticeable to national consumers, while producers benefit through increased economic returns, it makes sense that the producers pay for research. Just like the small-scale farmers have been paying for road maintenance in some countries in Africa, they should also be encouraged to pay for research.

Researchers in Africa should encourage this type of financing which should focus on inputs, machinery, equipment, and processing industries. Private expenditures on research in Africa should be higher than public expenditures. The growth in private research could be influenced by three factors namely: (1) the rapid development of the sector; (2) the legal framework in which they operate and the clarity that exists with regard to legal property rights; and (3) the density of the knowledge cloud. Industry invests in research when it finds itself in a conducive environment (Klotz et al., 1995).

Conclusions

Food and nutrition security for Africa can and must be achieved because it is a human rights issue as well as a moral and socio-economic imperative. Food and nutrition security in Africa must receive renewed attention and commitment from researchers in Africa and we must recognize that with business as usual the goals will not be achieved.

The highest priority actions of researchers in Africa should be to raise agricultural productivity, fostering

Table 1. Land management and crop yield in some African regions as compared to Europe and South East Asia.

	Population Density pop Km ²	Crop land % of total	Irrigated % of total	Average yield Cereals kg ha ⁻¹	Fertilizer use Kg/ha ⁻¹
Northern G. of Guinea	226	5	27	1,973	94
Central	891	21	2	892	15
Eastern	145	4	1	923	2
Southern	451	10	2	1,363	12
Thailand	208	6	7	929	27
U.K	1141	45	19	2,052	39
	2,404	28	2	6,332	350

Table 2. Percent increase in food production between 1961 and 1963 and 1989 to 1990 both in areas and yield per hectare.

Region	Increased area %	Increased yields %
SSA	42	52
Latin America	30	71
South Asia	14	86
East Asia	6	94
High Income Countries	2	98
World	8	92

Source: Rojanasoonthon et al., 2002.

Table 3. Average changes of the forest areas in the world.

Continent	Annual change (Thousand ha)	Annual change rate (%)
Africa	-5,262	-0.78
Asia	-364	-0.07
Oceanic	-365	-0.18
Europe	+881	+0.08
North and Central America	-570	-0.10
South America	-3,711	-0.41
Total world	-9391	-0.22

Source: Urushadze Tengiz, 2002.

pro-poor economic growth through improved markets, better infrastructure, and greater trade competitiveness, building institutional and human capacity, improving nutrition and health with due attention to HIV/AIDS, and strengthening governance. All of these require added resources, but the benefits of food and nutrition security outweigh the resource needs.

The rights of all who have a stake in achieving food security, especially food-insecure people must be respected, protected, facilitated, and fulfilled. Without mechanisms for generating improved incentives for good governance and accountability of all actors, no sustainable progress can be expected.

Sound decision-making and implementation of needed action is constrained by lack of capacity and by governance and institutional weakness. All three constraints must be addressed simultaneously. Implementation must focus on strong government capacity, strong farmers' organizations, strong incentives for the business sector to engage in agriculture and the food industry, strong consumers' associations, media, and strong health systems serving the needs of the poor.

References

- Ahmed M.M., Sanders J.H. and Nell W.T. 2000. New Sorghum and Millet Cultivar Introduction in Sub-Saharan Africa: Impacts and Research Agenda. *Agricultural Systems* 64 pp. 55–56.
- Annon. 1999. UNIDO Workshop on Alternatives to MB in the People's Republic of China. Beijing, 8–9 November 1999, 131 pp.
- Binswanger H. and Pingali P. 1988. Technology Priorities for Farming in Sub-Saharan Africa. *Research Observer* 3 (1) pp. 81–98.
- Delgado C. and Mellor W. 1984. A Structural View of Policy Issues in African Agricultural Development. *American Journal of Agricultural Economics*. 66 pp. 665–670.
- Dixon A.J., James D.E. and Paul B. Sherman 1989. The economics of dryland Management. Earthscan, London UK. 302
- FAO. 1984. A Guide to Staple Foods of the World. Rome.
- FAO/WHO. 1992. Major Issues for Nutrition Strategies Summary, FAO, Rome.
- Hazell P. 1995 Managing Agricultural Intensification, IFPRI, 2020 Brief No. 11 (IFPRI, Washington, DC).
- ICHI (Independent Commission on International Humanitarian Issues). 1986. The Encroaching Desert: The Consequences of Human Failure. Zed Books. London.
- IFPRI 2001. A 2020 Vision for Food, Agriculture and the Environment. Washington DC.
- Indicators of regional vulnerability in Africa (WRI, 1996). WRI, 1996: World Resources: A Guide to Global Environment, 1996–1997. World Resources Institute, United Nations Environment Program, World Bank, Oxford University Press, New York, NY, USA, 342 pp.

- International Food Policy Research Institute (IFPRI). 1995. "A 2020 Vision for Food, Agriculture, and the Environment," draft paper (IFPRI, Washington, DC).
- Klotz, C.A., K.O. Fuglie and C.E. Pray. 1995. Private-Sector agricultural research expenditures in the United States, 1960–1992. US Department of Agriculture Economic Research Service. AGES, 9525.
- Lal R. 1990. Low-Resource Agriculture Alternatives in Sub-Saharan Africa. *Journal of Soil and Water Conservation*. 43 pp. 437–444.
- Persley G.J. (ed.) 1998. Investment strategies for agriculture and natural resources. Wallingford: CABI Publishing.
- Rojanasoonthon S. and Kheoruenromne I. 2002. Tropical soil science. Realities and challenges. In: Proceedings for the 17th World Congress of Soil Society, 14-21 August 2002.
- Rutten H. 1999. Development in the organization and finance of public and finance of public agricultural research in the Netherlands, 1988-1999. Personal communication.
- Urushadze Tengiz F. 2002. Soils in space and time: realities and challenge for the 21st century. In: Proceedings for the 17th World Congress of Soil Society, 14-21 August 2002.
- World Bank. 1984. *Toward Sustainable Development in Sub-Saharan Africa: A Joint Program of Action*. Washington DC.
- World Bank. 2000. *World Development Report 2000/2001: Attacking Poverty*. Washington DC.
- World Food Summit News. 2002. Five years later, 10-13 June.
- World Resources Institute (WRI), 1996/97: *A Guide to the Global Environment*. WRI, UNEP, UNDP. The World Bank. New York.
- WRI, 1998: *1998–99 World Resources Database: A Guide to the Global Environment*. World Resources Institute, Washington, DC, USA.

Background, Current status and the African Context of the International Nitrogen Initiative

Mateete Bekunda¹, James Galloway², Keith Syers³, Mary Scholes⁴

¹ Makerere University, Uganda; ² University of Virginia, USA; ³ Naresuan University, Thailand; ⁴ University of Witwatersrand, South Africa; * Corresponding author: Makerere University, P.O. Box 7062, Kampala, Uganda. Email: mateete@agric.mak.ac.ug

Abstract

Over the past 40 years, world population has increased from about three to six billion with consequent increase in food demand. Food production has kept pace through the combined use of high-yielding varieties, fertilizers and improved crop management practices albeit at different scales across the globe. In Sub-Saharan Africa (with the exception of South Africa), the average application rate of manufactured fertilizers is around 8 kg ha⁻¹ of cultivated land compared with a world average estimated at 91 kg ha⁻¹. Thus fertilizers have been identified as one of the critical elements of the agricultural sector in Sub-Saharan Africa; application rates and use efficiency must be increased in order to restore soil fertility and preserve the fragile ecosystems. This fits in the International Nitrogen Initiative's overall goal which is to "Optimise nitrogen's beneficial role in sustainable food production and minimize nitrogen's negative effects on human health and the environment resulting from food and energy production". This requires identifying gaps in current scientific understanding, uncertainties, controversies, novel approaches, and priorities for research, in order to help define research agendas. An African Regional Centre of the Initiative is necessary to lead in developing the region's specific N issues and solutions, and selective options and plans for implementation of the solutions.

Key words: African Nitrogen Centre, fertilizers, nitrogen use efficiency

Introduction

Nitrogen (N) fertilizers have contributed to the increase in global food production over the past 50 years, tripling cereal grain production from 631 million tonnes in 1950 to 1,840 million tonnes in 2000 (Mosier et al., 2004a). It is the cereal grain production that has largely dictated the global demand for N fertilizer (Cassman et al., 2002). During 1995/1997 ~ 65% of the global N fertilizer consumed was for producing cereal grains (IFA / FAO, 2001). Fertilizer N has contributed an estimated 40% to the increases in per capita food production over the past 50 years (Smil, 2002). IFA and FAO (2001) projects that the relative amount of

N fertilizer used by 2015 will remain unchanged but total N consumption in cereal production will increase by about 15%, so as to meet demands from human population growth.

The global values of fertilizer use and cereal production reflect local and regional differences in demand, supply and efficiencies of fertilizer use in crop production (Table 1). In 2001, for example, the per capita fertilizer N consumption was 38, 22, 11 and 1.1 kg person⁻¹ in the USA, China, India and Sub-Saharan Africa, respectively (Mosier et al., 2004a). Even within Africa, there are large differences in fertilizer nitrogen consumption (Table 2). This is a result of inequities in costs and availability of the fertilizers.

Table 1. Comparative use of fertiliser N in some selected regions and countries during 2001 (adapted from Maene and Heffer, 2004).

Region/Country	World	Sub-Saharan Africa	France	India	Uganda
N consumption ('000t)	82445	680	2398	11309	4
Application (kg ha ⁻¹)	54	4	122	67	0.5
Cereal yield (t ha ⁻¹)	3.1	1.0	6.7	2.4	1.6

Table 2. Comparative fertiliser N consumption by some African countries during 2001 (adapted from Maene and Heffer, 2004).

Country	Consumption ('000t)
Egypt	1150
South Africa	393
Ethiopia	111
Kenya	82
Sudan	70
Cameroon	26
Zambia	12
Uganda	4

In areas where fertilizer availability and cost are not limiting, excessive fertilizer is sometimes used, and can lead to several problems related to ecosystem vulnerability (e.g. acidification, eutrophication; Mosier et al., 2004a), and to human health (e.g. exposure to high concentrations of ozone). To minimize the pollution problems, it is essential that the efficiency of fertilizer N use be improved.

The limited availability of fertilizers in Sub-Saharan Africa has contributed to the decline in soil fertility through the loss of organic matter (Syers, 1997), which is supported by persistent negative N balances over time. Smaling et al. (2002) reported an average of 22–25 kg N loss per ha per year during the period 1983–2000, mainly due to removal of harvested product and erosion. But even where N fertilizer use is low, the efficiency of use of that N may be lower than in areas where consumption is higher, typically caused by insufficiency of other required nutrients (e.g. P, K, and secondary and micronutrients) which limit plant growth along with N.

In general, fertilizer N has not been used efficiently. On average, about 38% of the N applied to soil for cereal crop production is taken up (Table 3), and while grain production over the last 40 years increased by 140%, nitrogen use increased by 600% (Mosier et al., 2004a). So, unless there are significant advances in N use efficiency, the N required to increase yield by 40% in order to meet world food demand in 2025 (FAO, 2001) has the potential to further degrade water and air quality.

Table 3. Fertiliser N recovery efficiency (REN) in grain by maize, rice and wheat across regions of the world (adapted from Krupnik et al., 2004).

Region Crop	N fertiliser rate (kg ha ⁻¹)	Number of observations	Mean fertiliser N recovery (%)
Africa			
Rice	124	47	24
Wheat	138	4	49
Australia			
Rice	175	6	32
Wheat	89	42	38
Eurasia			
Rice	115	3	41
Wheat	119	7	27
Europe			
Wheat	156	78	43
North America			
Maize	139	46	39
Wheat	91	222	35
South America			
Maize	240	3	31
Rice	120	9	39
Wheat	126	10	69
South Asia			
Maize	80	3	30
Rice	213	213	39
Wheat	55	55	49
AVERAGE			38

The role of the International Nitrogen Initiative (INI)

Formation of INI. In 1978 the Scientific Committee on Problems of the Environment (SCOPE) and United Nations Environment Programme (UNEP) established the International Nitrogen Unit which led to the first assessment of existing knowledge (Clark and Rosswall, 1981). In the intervening years SCOPE has sponsored a number of studies focused on N, including the International SCOPE project on Nitrogen Transport and Transformations. This project ran from 1994 to 2002 and was designed to analyze nitrogen flows at the scale of large regions. Several

major reports were produced, the most recent being Boyer and Howarth (2002).

In keeping with the advancement in knowledge on N biogeochemistry achieved by SCOPE and other organizations, there have been two major international conferences on N over the last four years, with a third conference scheduled for 2004. The First International Nitrogen Conference, with a focus on Europe, was held in the Netherlands in March 1998 (van der Hoek et al., 1998). Three years later, the Second International Nitrogen Conference was held in the USA in October 2001 with a focus on North America and Europe (Galloway et al., 2002). The Third Conference, sponsored by the Chinese Academy of Sciences and other organizations, will be held in Nanjing, China in October 2004. The focus of the Third Conference will be Asia.

The Second Conference established as a goal the development of a sustainable approach to manage nitrogen, and thus be able to provide food and energy to the world, yet minimize release of nitrogen to the environment. Towards the realization of this goal, one of the recommendations of the Conference was to establish the International Nitrogen Initiative (INI). This was endorsed at a Workshop titled "Nitrogen Management for Food Security and Ecosystem Security" held as part of the Science Forum associated with the World Summit on Sustainable Development in Johannesburg August 29, 2002. In December 2002, both SCOPE and the International Geosphere–Biosphere Programme (IGBP) agreed to become founding sponsors of the INI.

INI Structure. INI is governed by a Steering Committee (Chair: Jim Galloway (USA); Members: Mateete Bekunda (Uganda), Jan Willem Erisman (The Netherlands), John Freney (Australia), R.W. Howarth (USA), Luiz Martinelli (Brazil), Mary Scholes (South Africa), Sybil Seitzinger (USA), Zhou Jianmin (China)) that receives advice from a Science Advisory Committee. The Steering Committee oversees coordination among the different parts of the program and conducts cross-cut activities at global level. The INI is establishing a presence in the regions of North America, Latin America, Asia, Europe and Africa. Each region has a Director or Coordinator that is working on identifying the interested community, and developing a funding base. The activities of any given Centre will depend upon

the 'maturity' of nitrogen science and policy for that region.

INI Strategy. The INI (and its regional centres) will use a three-phased approach, designed around the program objectives, to work towards the overall goal of the INI, *Optimise nitrogen's beneficial role in sustainable food production and minimize nitrogen's negative effects on human health and the environment resulting from food and energy production:*

- Phase I: Assessment of knowledge on N flows and problems
- Phase II: Development of region-specific solutions to problems identified in phase I.
- Phase III: Implementation of scientific, engineering and policy tools to implement these solutions, in collaboration with critical stakeholder groups.

Phase I is being organized around crosscutting themes at both global and regional levels; initial themes are natural processes (e.g., biological N fixation, denitrification), agriculture, fertilizers, animal production, human waste, energy production/use.

Regional Centres will initially develop an integrated database on nitrogen, useable by a wide variety of interested groups (e.g., scientists, industry representatives, and policy makers), and promote both research and education on nitrogen-related issues. An important activity of each Regional Group is not only to make the assessment of the state of knowledge on N cycle alterations (and associated issues) but also to identify the constituencies within each region that should be involved in Phase III. The Guidelines for the Millennium Ecosystem Assessment, 2004, will be adopted for this process.

INI Activities 2003–2004

We envision that INI will become a long-term programme, with a variety of international, regional and national partners joining the programme over the years. The activities described below, either as part of INI or associated with it, cover the first two years of the programme:

- March 2003, Ubatuba, Brazil, workshop on N fluxes and processes in tropical and temperate systems. L. Martinelli and R. Howarth, co-chairs
- January 2004, Nitrogen Fertilizer: Assessment of Needs and Problems Workshop (A SCOPE Rapid

Assessment Project) (NFRAP) Kampala, Uganda. A book has been published as SCOPE Series 65 (Mosier et al., 2004b)

- May 2004, Advanced Approaches to Quantify Denitrification Workshop, Woods Hole, MA, USA; May 3–5. Eric Davidson and Sybil Seitzinger, co-chairs
- October 2004. 3rd International N Conference. Nanjing, China, October 12–16. Impacts of Population Growth and Economic Development on the Nitrogen Cycle: Consequences and Mitigation at Local, Regional and Global Scales Zhaoliang Zhu (China) and Katsu Minami (Japan), co-chairs.

The African Nitrogen Centre

Globally, the nitrogen cycle is the most altered of any major element cycle. Human activity has doubled the rate of formation of reactive nitrogen on the land surfaces of the Earth over natural rates. The change is recent and rapid, making accelerated nitrogen cycling one of the most immediate and consequential facets of global change. But the alteration of the nitrogen cycle is not uniform, and regional variation raises the need for assessments at regional to continental scales. The African Nitrogen Centre is one of five globally distributed centres of the International Nitrogen Initiative charged with assessing how human activity has altered nitrogen flows within Africa, determining the consequences of this alteration, and helping to develop solutions to reduce the problem.

Although the rate of formation and use of N is low at the continental level, there is variation within Africa, with very little change in some regions (no influence in human activity) and vast changes in others (overuse of fertilizer N, but mainly through N mining). The drivers of change in the N cycle (e.g. agriculture, use of synthetic fertilizers, release of N pollutants during fuel combustion, influence of climate and climate change, landscape alteration) and their consequences in Africa are perhaps only qualitatively known, which is not enough for policy intervention advice. It is proposed therefore, that the African Nitrogen Centre will work collaboratively with other institutions and organizations to achieve goals that will include:

- Comprehensive and quantitative assessment of ecological and human health consequences of N use (or lack of) and the drivers of change in the nitrogen cycling across the regions of Africa (it is

Background, Current status and the African Context

envisaged that will necessarily form baseline data against which future intensification of N use will be compared)

- Developing policy options for increasing N use efficiency and encouraging pilot studies to test potential policies and technical solutions.
- Communicating the issues of human acceleration of the nitrogen cycle to the public and to decision makers, and to facilitate communication and interaction among the scientific community.

References

- Boyer E.W. and Howarth R.W. 2002. *The nitrogen cycle at regional to global scales*. Dordrecht, The Netherlands: Kluwer Academic Publishers.
- Cassman K.G., Dobermann A. and Walters D. 2002. Agroecosystems, nitrogen-use efficiency, and nitrogen management. *Ambio* 31:132–140.
- Clark F.E and Rosswall T. (eds). 1981. *Terrestrial Nitrogen Cycles. Processes, Ecosystems Strategies and management Impact*. Ecol. Bull. (Stockholm) 33.
- FAO (Food and Agriculture Organisation of the United Nations), 2001. *FAOSTAT Database collections*. <http://www.apps.fao.org>.
- Galloway J.N., Cowling E.B. and Kessler E. (eds). 2002. Optimising Nitrogen Management in Food and Energy Production, and Environmental Change. *Ambio* (Special Issue) 31 (2).
- IFA (International Fertiliser Industry Association)FAO. 2001. *Global estimates of gaseous emissions of NH₃, NO and N₂O from agricultural land*. Rome: FAO.
- Krupnik T.J., Six J., Ladha J.K., Paine M.J. and van Kessel C. 2004. An assessment of fertiliser nitrogen recovery efficiency by grain crops. pp. 193–207. In: Mosier A.R., Syers J.K. and Freney J.R. (Eds) *Agriculture and the nitrogen cycle: assessing the impacts of fertilizer use on food production and the environment*, SCOPE; 65: Island Press.
- Maene L.M. and Heffer P. 2004. Current situation and prospects for fertiliser use in Sub-Saharan Africa. Unpublished paper presented at the Symposium on Nitrogen and Crop Production in Uganda. Makerere University, Kampala, Uganda, 14 January 2004.
- Mosier A.R., Syers J.K. and Freney J.R. 2004a. Nitrogen Fertilizer: An Essential Component of Increased Food, Feed and Fiber Production. pp. 3–15. In: Mosier A.R., Syers J.K. and Freney J.R. (Eds) *Agriculture and the nitrogen cycle: assessing the impacts of fertilizer use on food production and the environment*, SCOPE; 65: Island Press.
- Mosier A.R., Syers J.K. and Freney J.R. (Eds) 2004b. *Agriculture and the nitrogen cycle: assessing the impacts of fertilizer use on food production and the environment*. SCOPE; 65: Island Press.
- Smaling E.M.A., Stoorvogel J.J and de Jager A. 2002. Decision making on integrated nutrient management through the eyes of the

- scientist, the land-user and the policy maker. pp. 265—284. In: Vanlauwe B., Diels J., Sanginga N. and Merckx R. (Eds) *Integrated plant nutrient management in Sub-Saharan Africa: From concept to practice.*, Wallingford, UK: CABI Publishing.
- Smil V. 2002. Nitrogen and food production: proteins for human diets. *Ambio* 31:126–131.
- Syers J.K. 1997. Managing soils for long-term productivity. *Philosophical Transactions of the Royal Society of London (B)* 352:1011–1020.
- van der Hoek K.W., Erisman J.W., Smeulders S., Wisniewski J. W. and Wisniewski J. (Eds). 1998. Proceedings of the First International Nitrogen Conference. Elsevier Science.

Within-farm soil fertility gradients affect response of maize to fertiliser application in western Kenya

B Vanlauwe^{1,*}, P Tittonell² and J Mukalama¹

¹Tropical Soil Biology and Fertility Institute of the International Centre for Tropical Agriculture (TSBF-CIAT), P.O. Box 30677, Nairobi, Kenya; ²Plant Production Systems, Department of Plant Sciences, Wageningen University, P.O. Box 430, 6700 AK Wageningen, The Netherlands; *Author for correspondence (e-mail: b.vanlauwe@cgiar.org; fax: +254-20-7224763)

Key words: Limiting nutrient trial, NPK application, Olsen-P, Soil fertility gradients

Abstract

Different fields within a farm have been observed to have different soil fertility status and this may affect the response of a maize crop to applied N, P, and K fertiliser. A limiting nutrient trial was carried out at six farms each, in three districts of Western Kenya. In each of the farms, the following treatments were laid out in three fields with different soil fertility status at different distances from the homestead (close, mid-distance, remote fields): no inputs, application of NPK, NP, NK, or PK fertiliser (urea, triple super phosphate, KCl) to maize. Total soil N decreased at all sites with distance to the homestead (from 1.30 to 1.06 g kg⁻¹), as did Olsen-P (from 10.5 to 2.3 mg kg⁻¹). Grain yields in the no-input control plots reflected this decrease in soil fertility status with distance to the homestead (from 2.59 to 1.59 t ha⁻¹). In the NPK treatments, however, this difference between field types disappeared (from 3.43 to 3.98 t ha⁻¹), indicating that N and P are the major limiting nutrients in the target areas. Response to applied N was related to the soil total N content in Aludeka and Shinyalu, but not in Emuhaia, probably related to the high use of partially decomposed organic inputs with limited N availability. Consequently, response to applied N decreased with distance to the homestead in Aludeka (from 0.95 kg kg⁻¹ relative yield to 0.55 kg kg⁻¹) and Shinyalu (from 0.76 kg kg⁻¹ to 0.47 kg kg⁻¹), but not in Emuhaia (from 0.75 kg kg⁻¹ to 0.68 kg kg⁻¹). Response to applied P was related to the soil Olsen-P content at all sites. While for farms with a relatively high Olsen-P gradient, response to applied P decreased with distance to the homestead (from 0.99 kg kg⁻¹ to 0.68 kg kg⁻¹), large variability in Olsen-P gradients across field types among farms within a specific site often masked clear differences in response to P between field types for a specific site. Clear scope for field-specific fertiliser recommendations exists, provided these are based on local soil knowledge and diagnosis. Scenario analysis, using farm-scale modelling tools, could assist in determining optimum allocation strategies of scarcely available fertiliser for maximum fertiliser use efficiency.

Introduction

Although regional and national estimates of nutrient balances are negative for all major nutrient in most of sub-Saharan Africa, large differ-

ences in nutrient balances can often be observed between fields within a farm – some field even showing positive balances, resulting in substantial differences in soil fertility status between those fields (Smaling et al. 2002). In a study in Burkina

This article has been previously published in the journal “Nutrient Cycling in Agroecosystems” Volume 76 Issues 2–3.

Faso, West Africa, Prudencio (1993) observed a variation in soil C at farm level from 0.2 to 2.2% from the bush fields to the homestead fields, where different cropping patterns and frequencies of cultivation were generally observed in concentric rings around the village composed of household compounds (ring management system), resulting in concentric gradients with increasing soil fertility status near the village. Gradients in both soil fertility status and in soil nutrient balances have also been reported for 'village fields' and 'bush fields' in central Mali (Dembélé et al. 2000). Typically, smallholder farming systems in Uganda contain three enterprise areas (Woomer et al. 1998): 'outfields' cultivated in cereal-legume intercrops mainly intended for home consumption, 'infields' of market crops, and home sites where livestock are confined, manures and composts accumulated and kitchen gardens cultivated.

Although differences in soil fertility status among fields within a farm are common, less clear is their origin. Since in most of the examples given above, soil fertility tended to decrease with distance from the homestead, the term 'gradients' will be used hereafter. Possible causes underlying these fertility gradients at the farm level are differences in inherent soil properties due to a specific position in the landscape, referred to as soilscape by Deckers (2002), distance to the homestead, or farmer-induced differences in management of the different fields. In Uganda, crop residues from the 'outfields' are harvested, fed to livestock and manures applied to crops intended for the market, resulting in nutrient mining of 'outfield' soils and the creation of characteristic patches, plots and fields of nutrient-deficient crops (Woomer et al. 1998). In a study in Central Kenya, Murage et al. (2000) reported differences in chemical and biological soil properties of productive and non-productive fields within a farm. Since clay and sand contents did not vary between soil categories in their study, they suggested that these differences in chemical and biological soil properties are not inherent but result from past soil management. Their findings reveal that farmers are more likely to allocate their limited organic resources and fertilisers to higher value crops in more productive areas of the farm than to attempt amelioration of fertility-depleted fields.

The highlands of western Kenya support one of the densest rural populations in the world, as a

result of large initial settlements attracted by the originally fertile soils in the area. Population growth has led to gradual depletion of nutrients through export in crop products, leaching, and soil erosion, for which farmers have been unable to compensate via imported organic resources or mineral fertilisers (Shepherd and Soule, 1998). Tiftonell et al. (2005a) observed on smallholder farms in Western Kenya that soil fertility indicators and nutrient concentrations varied quite consistently between different land quality classes, according to farmers' criteria. Partial N balances were negative in most fields of all farm types, except for the home gardens of the wealthiest farm types. Residue incorporation took place mainly in the home gardens followed by the close fields, however, the wealthiest farm types incorporated most of the crop residues in all fields. The use of organic fertilisers varied clearly for different field types and was strongly affected by distance from the homestead and type of crop.

Various soil fertility management options have been developed to tackle soil nutrient mining and restore the soil fertility status. Nowadays, there is general consensus, both in the research and development community dealing with soil fertility management, that improving soil fertility requires both mineral fertilisers and organic inputs (Vanlauwe et al. 2002a). However, while information on the soil fertility status of different fields within a farm is relatively abundant, information is scanty on the consequences of such soil fertility gradients for the efficiency of different soil fertility management options, in terms of crop yield increases and/or enhancement in soil fertility status, is scanty. Vanlauwe et al. (2000), for instance, reported varying response to P for different positions in the landscape in the Northern Guinea savanna of West-Africa.

The objectives of the current study were (i) to determine maize crop production as affected by differences in soil fertility status for different fields within a farm, (ii) to quantify field-specific responses to applied N, P, and K fertiliser, and (iii) to evaluate relationships between initial soil fertility characteristics and responses to fertiliser N, P, and K. The working hypothesis was that the initial soil fertility status has a significant impact on responses to fertiliser that is large enough to warrant inclusion of information on the soil fertility status in site-specific fertiliser recommendations.

Materials and methods

Target sites and selection of farms

The study was carried out in the Western Province of Kenya, in Emuhaia (0°4' N; 34°38' E), Shinyalu (0°12' N; 34°48' E), and Aludeka (0°35' N; 34°19' E) divisions, in Vihiga, Kakamega and Teso districts, respectively. A detailed description of the study area is given in Tittonell et al. (2005a). Here only the main characteristics are reported. Average annual rainfall is 1850 mm in Emuhaia, 2145 mm in Shinyalu, and 1463 mm in Aludeka, distributed over two cropping seasons: the long rains from March to July and the short rains from August to November. Average altitude is 1640 m asl for Emuhaia, 1820 masl for Shinyalu, and 1180 m asl for Aludeka, while average annual temperatures are 20.4 °C in Emuhaia, 20.8 °C in Shinyalu, and 22.2 °C in Aludeka. Average farm size is 0.7 ha in Emuhaia, 1.3 in Shinyalu, and 2.1 in Aludeka, with population density decreasing from 930 to 310 people km⁻² in the same order. In Emuhaia and Shinyalu, most farms were concentrated on Nitisols and Ferralsols, whereas in Aludeka, farms were on Acrisols. While in Emuhaia and Shinyalu soil types varied between the crest, slope, and valleys positions in an indulating landscape, soil depth and texture were the main sources of biophysical variability within the farms of Aludeka, due to the relatively flat landscape. Soil organic C values varied between 10.5 and 12.9 g kg⁻¹ in Emuhaia, between 17.2 and 18.5 g kg⁻¹ in Shinyalu, and between 6.9 and 8.8 g kg⁻¹ in Aludeka while pH in water varied between 5.1 and 6.1 in Emuhaia, between 5.2 and 5.7 in Shinyalu, and between 5.2 and 5.8 in Aludeka (Tittonell et al. 2005b). Topsoil silt + clay content varied between 497 and 531 g kg⁻¹ in Emuhaia, between 762 and 788 g kg⁻¹ in Shinyalu, and between 361 and 443 g kg⁻¹ in Aludeka (Tittonell et al. 2005b).

In Emuhaia and Shinyalu the homestead was normally located in the uppermost part of the farm, near the roads that generally run along the top of the ridges in this heavily dissected landscape. Bananas and vegetables intercropped with pulses and cereals were grown around the house. In some farms of Shinyalu, the homestead had been moved to a different place within the farm after about 10 to 15 years, to make use of the

accumulated fertility by growing crops. In Aludeka, the homestead was often placed in the centre of the farm and surrounded by banana plants and fruit trees. Maize and groundnuts tended to be grown nearer the house, while cassava and finger millet were mainly found in further fields. In the few farms with cattle, the animals were kept in a boma (stall) during the night (Tittonell et al. 2005a).

In each division, six farms were chosen to include farmers from different social status or resource endowment (two with high, medium, and low access to resources) and gender (Table 1). Farm size of the selected farms varied between 0.4 and 5.0 ha across the divisions and farms contained between 4 and 14 primary production units (PPU) or fields that are usually managed in a uniform way. For most of the farms selected, resource flow analysis, farm transects and soil profile observations, geo-referenced soil sampling and analysis, maize yield estimates, and farmers' classification of soil fertility status were done previously (Tittonell et al. 2005a, b). A third requisite for farm selection was related to securing the results of the experiments, by choosing highly motivated farmers for collaboration in implementing and evaluating the experiments.

Treatment structure and trial implementation

In each of the farms, 3 fields (close field, mid-distance field, remote field) were chosen at different distances to the homestead, from all primary production units (PPU) within a farm (Table 1). The criterion of Relative Distance from the Homestead (RDH) related the absolute distance between the PPU and the homestead to the average distance between the furthest fields and the homestead. RDH was used to distinguish field types (RDH's = 0.1–0.3; 0.3–0.6; 0.6–1.0, respectively – Tittonell et al. 2005b), together with the results of resource flow analysis that revealed different patterns of resource allocation and intensity of input use in those fields. Farmers' opinion on the soil fertility status of the different fields was also solicited while choosing fields to be used. Homegardens were excluded as in these fields maize usually grows in association with cassava, sugar cane or banana, quite often in competition with other garden crops. Fields with strong

Table 1. Selected characteristics of the households used in the current study.

Division	Farmer	Gender	Typology ^a	Farm size (ha)	PPU ^b Number
Emuhaia	Joash Mukora	Male	4	0.4	6
	Jairus Lusuli	Male	2	1.4	4
	Sarah Mukabi	Female	3	0.9	5
	Sophia Agoi	Female	5	0.8	4
	Dorcas Nakaya	Male	3	0.7	4
	Refa Oluchina	Female	2	2.7	8
Aludeka	Joseph Ebu	Male	1	1.3	8
	John Obonyo	Male	4	0.7	6
	Kefina Ikaelon	Female	5	0.5	5
	Lazaro Osirom	Male	5	0.9	8
	Joseph Ochudi	Male	3	2.5	8
	Ernest Okitwi	Male	2	5.0	14
Shinyalu	Jane Nyerere	Female	5	0.5	6
	Alpine Shibonje	Male	2	3.0	13
	Lucia Khaukani	Female	5	1.4	8
	Peter Shivayanga	Male	3	2.1	11
	Elphas Lichalus	Male	4	0.9	5
	Rose Analo	Female	2	1.6	5

Data adapted from Tittonell et al. (2005a).

^aFarmer typologies were defined based on the occurrence of specific production units and availability of labour and off-farm income (Tittonell et al. 2005a). Overall resource endowment of the farmers tends to decrease with increasing typology number.

^b‘PPU’ means ‘primary production unit’. A PPU is a crop activity consisting of one or various crops grown deliberately in one field within the farm, taking place over a specific period of time, and managed in a similar way. At the study sites, PPUs are often delineated by hedges or terraces.

impediments (e.g., steep slopes, shallow soils, lots of shade) were also avoided, as were fields that were too remote from the homestead (i.e. difficult to access due to topography or isolated, far from the homestead and prone to theft) and/or difficult to keep under controlled conditions (e.g. unfenced fields prone to be grazed by cattle).

In each of the fields, 5 treatments were laid out on plots of 4.5 by 2.25 m, following a one-farm one-replicate design: a no-input control, a fully fertilised treatment (100 kg N ha⁻¹, 100 kg P ha⁻¹, and 100 kg K ha⁻¹), and three treatments with one of the major nutrients (N, P, or K) missing. Fertilisers were applied as urea, triple super phosphate, and muriate of potash. Between 6 and 14 September during the short rains of 2002, maize (variety Hybrid HB513) was planted at a distance of 75 cm between the rows and 25 cm within the rows and thinned to one plant per hill, about 3 weeks after germination. One third of the N fertiliser and the P and K fertilisers were applied broadcast on the entire plot and incorporated before planting. The plots were hoe-weeded three times during the growing season. At the 5th week after planting, two thirds of the N fertiliser was top dressed by banding urea in the rows of maize. At

the same time, insecticide (Bulldock 025EC, granular, active ingredient 25 g l⁻¹ beta-cyfluthrin) was applied in the funnels of the maize leaves to control maize stemborer. Whenever a termite attack was visible, insecticide (Gladiator 4TC, liquid, active ingredient 480 g l⁻¹ chlorpyrifos) was applied at the base of the maize plants to control this damage. No moisture stress or excess rainfall occurred during the entire season at any of the sites.

Measurements and chemical analyses

Topsoil (0–15 cm) samples were taken with an auger at eight sampling points (4 on each diagonal) per field from the three fields chosen within each farm. Soil samples were air-dried, sieved through 2 mm, stored at room temperature, and analysed for total N and available Olsen-P following standard methods (Anderson and Ingram 1993). Maize was harvested at about 15 weeks after planting (between 23 December 2002 and 13 January 2003) from an area of 3 m by 0.75 m (1 line of 3 m long, containing 12 plants), excluding one border row on each site of the harvested area.

Maize ears and stover were weighed and sub-sampled. The sub-samples were dried (65 °C until constant weight) and the grains and inner cobs separated and weighed.

Mathematical and statistical analyses

The relative biomass yield in absence of a specific nutrient (N, P, or K) was calculated as:

$$RY_X = \frac{\text{Aboveground biomass in the treatment without application of } X}{\text{Aboveground biomass in the treatment with N, P, and K applied}} \quad (1)$$

In the above equation, X stands for N, P, or K. RY_X approaches 1 as the response to an applied nutrient X becomes 0.

In the statistical analysis, emphasis was put on overall field characteristics, rather than on differences between specific treatments. Initial soil total N and Olsen-P data, maize grain yields in the control treatment and in the treatment with NPK applied, and RY_X data were analysed using the MIXED procedure of SAS (SAS 1992) and standard errors of the difference (SED) were calculated using the LSMEANS (least square means) option. In the mixed model analysis, 'division', 'field type', and their interaction was used as a fixed factor and 'farm (division)' as a random factor, according to the following linear model:

$$\begin{aligned} \text{Observation}_{ijk} = & \text{Mean} + \text{Division}_i \\ & + \text{Field Type}_j + \text{Farm}_{ik} \\ & + \text{Residual}_{ijk} \end{aligned} \quad (2)$$

with i the number of divisions (3), j the number of field types (3), and k the number of farms used (18).

Means were separated using the PDIF option of the LSMEANS procedure. Simple regression was used to relate site-specific responses to initial soil total N and Olsen-P contents.

Results

Soil fertility status

Close fields had a significantly higher total N and Olsen-P content than the remote fields for all sites

with values for the mid-distance fields falling in between (Table 2). For all field types, soil total N content followed the order: Shinyalu > Emuhaia > Aludeka, while differences in Olsen-P content between sites were not significantly different for all field types (Table 2). For the close fields, however, Olsen-P values varied much between farms at all sites (Aludeka: 1.8–25.1 mg kg⁻¹; Emuhaia: 2.8–29.8 mg kg⁻¹; Shinyalu: 2.6–24.8 mg kg⁻¹). Olsen-P values of the mid-distance and remote

fields varied much less between farms. Farmer resource endowment (Table 1) was not observed to have a significant impact on the soil total N nor on the soil Olsen-P content (data not shown).

Maize yields

At the Aludeka and Shinyalu sites, maize grain yields in the control plots (without fertiliser inputs) were significantly larger (1.17–1.30 t ha⁻¹) in the close than in the remote fields (Figure 1a). Differences between the mid-distance and remote fields were not statistically significant. In Emuhaia, yields in the control plots were not significantly different between the different field types. Grain yields were lower in Shinyalu than in both other sites for all field types, but only significantly at the 10% level (Figure 1a). In the NPK treatments, maize grain yields were not significantly different between field types for all sites (Figure 1b). Yields in Aludeka were similar to yields in Emuhaia and significantly higher than in Shinyalu, although not always at the 5% level (Figure 1b).

RY_N was significantly lower than 1, indicating response to applied N, for all field types and sites, except for the close fields in Aludeka (Figure 2a). In Aludeka, RY_N was significantly higher in the close than in the other two fields, while in Shinyalu, the remote fields had a significantly lower RY_N than the other two field types. In Emuhaia, no differences in RY_N were observed between the field types. For the same field type, RY_N was not significantly different between sites (Figure 2a). RY_P was significantly lower than 1, indicating response to applied P, for all fields and sites, except

Table 2. Initial soil total N and Olsen-P content of the three field types.

Division	Field type	Total N (g kg^{-1})	Olsen-P (mg kg^{-1})
Emuhaia	Close fields	1.34	11.10
	Mid-distance fields	1.17	4.83
	Remote fields	1.10	1.72
Aludeka	Close fields	0.88	10.34
	Mid-distance fields	0.62	3.17
	Remote fields	0.62	2.80
Shinyalu	Close fields	1.67	10.05
	Mid-distance fields	1.56	3.80
	Remote field	1.47	2.46
SED(field) ^a		0.09	3.14
SED(site) ^a		0.11	3.40

^aSED(field) is the Standard Error of the Difference to compare field type for the same division; SED(site) is the Standard Error of the Difference to compare divisions for the same field type.

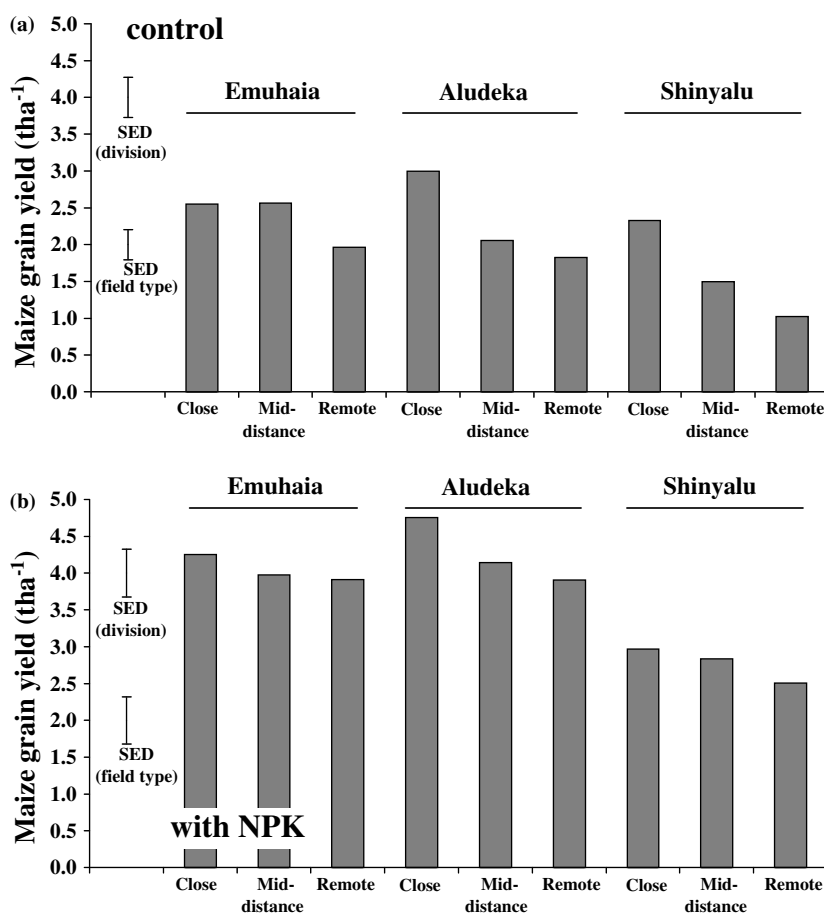

Figure 1. Grain yield in the no-input control plots (a) and in the plots with N, P, and K fertiliser added (b) for the different field types and divisions ($n = 6$). The error bars are Standard Errors of the Difference.

for the mid-distance fields in Emuhaia and the close fields in Shinyalu (Figure 2b). In Emuhaia, RY_P in the mid-distance fields was significantly

higher than in the remote fields, while in Shinyalu, RY_P was significantly higher in the close than in the two other field types. In Aludeka, no

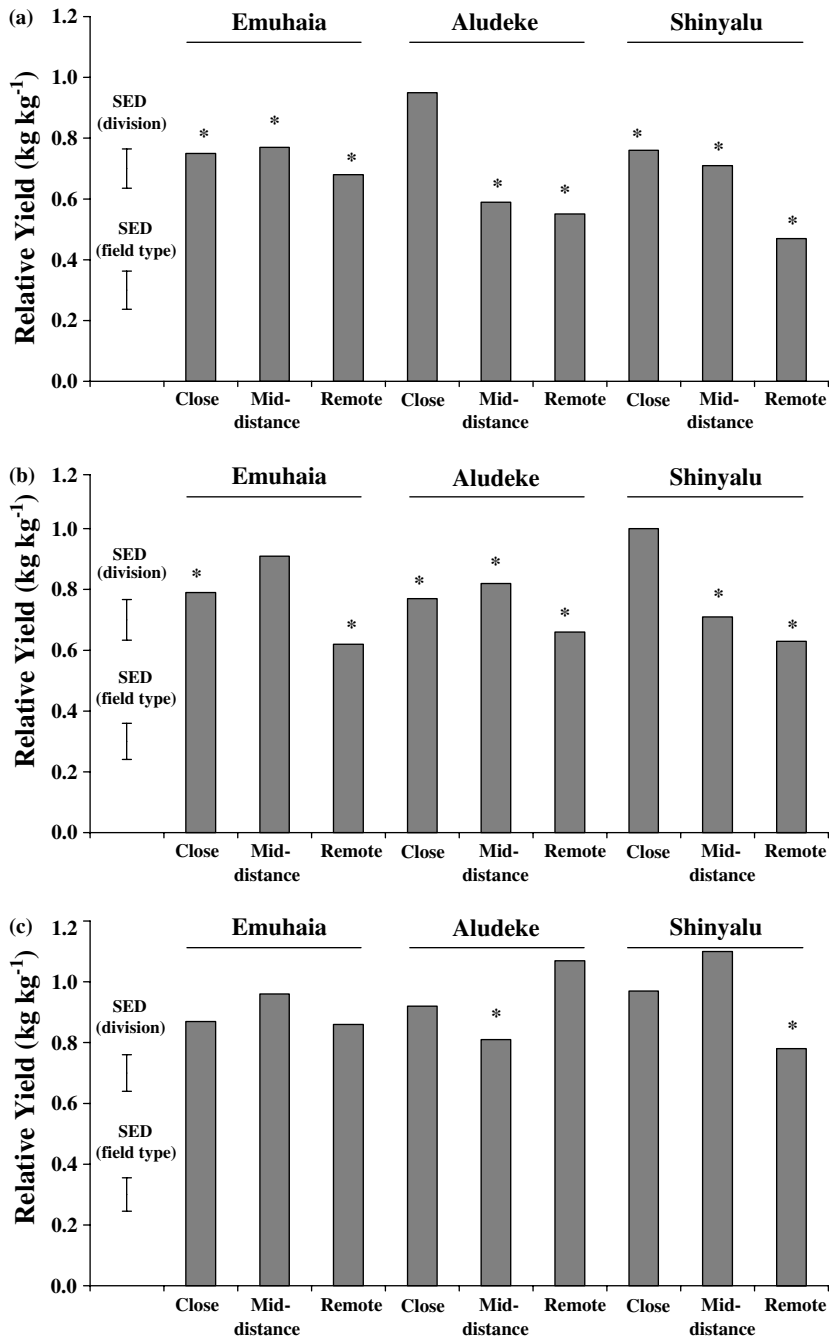

Figure 2. Relative total aboveground biomass yields in absence of N (a), P (b), and K (c) for the different field types and divisions ($n = 6$). ‘SED’ means ‘Standard Error of the Difference’. Bars indicated with ‘*’ are significantly different from 1 at the 5% level. The lowest bars indicate the strongest response to the missing element.

differences in RY_P between field types were observed. For the same field type, RY_P was not significantly different between sites (Figure 2b).

When considering the farms with relatively large differences in Olsen-P content between the close and remote fields, the close fields had a significantly

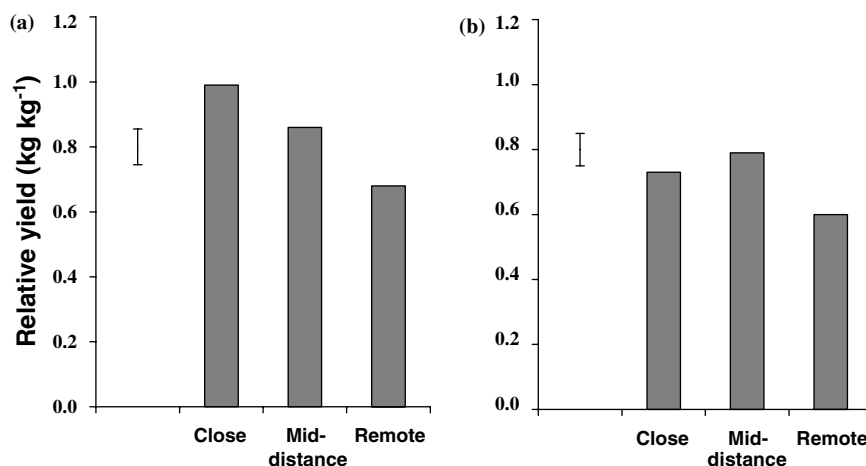

Figure 3. Relative total aboveground biomass yields in absence of P for the fields with the highest Olsen-P gradients across the three field types (difference in Olsen-P > 5 mg kg⁻¹) across the 3 sites (8 farms) (a) and those with the lowest Olsen-P gradients across the three field types (difference in Olsen-P < 5 mg kg⁻¹) across the three sites (10 farms) (b). The error bars are Standard Errors of the Difference.

larger RY_P than the other two field types (Figure 3a) while for the other farms, no differences in RY_P between field types were observed (Figure 3b). RY_K was significantly lower than 1, indicating response to applied K, only for the mid-distance fields in Aludeka and the remote fields in Shinyalu (Figure 2c). For the mid-distance fields, RY_K was significantly higher in Shinyalu than in Aludeka, while the reverse was true for the remote fields (Figure 2c).

Relationships between responses to applied nutrients and soil fertility status

RY_N was significantly related to the initial soil total N content in Aludeka and Shinyalu but not in Emuhaia (Figure 4a). For the same level of soil total N, RY_N was higher in Aludeka than in Shinyalu, indicating less response to applied N at Aludeka (Figure 4a). RY_P tended to reach a plateau for Olsen-P values above 8 mg kg⁻¹ and to decrease with further increases in Olsen-P. No differences in relationships between RY_P and Olsen-P contents were observed between the three sites (Figure 4b). As most fields did not show response to applied K, no attempts were made to relate RY_K to the initial soil K status.

Discussion

Maize grain yield (Figure 1) and total biomass production (data not shown) in the absence of fertiliser inputs decreased with increasing distance to the homestead and related decreasing soil fertility status (Table 2) at all sites, although the decline in yields was less steep in Emuhaia. In Northern Nigeria, Carsky et al. (1998) equally observed that compound fields close to the homestead produced substantially larger amounts of maize than fields further away. Important to note is that the relative area of each of the field types is not equal for a specific farm, with the close fields with high soil fertility status often occupying only a marginal area of the total farm (Tittonell et al. 2005b). With NPK fertiliser additions, differences in maize grain yield between field types were smaller than for the control soils, indicating that low soil available N, P, and/or K are the most limiting factors to maize production. An implication is that different amounts of fertiliser inputs are needed to achieve similar yields on the different field types, indicating that the response to applied inputs or their agronomic use efficiency is likely to decrease with increasing soil fertility status. Using ¹⁵N labelled urea under on-farm conditions in Southern Benin and Northern Nigeria, Vanlauwe et al. (2004) observed contrasting relationships

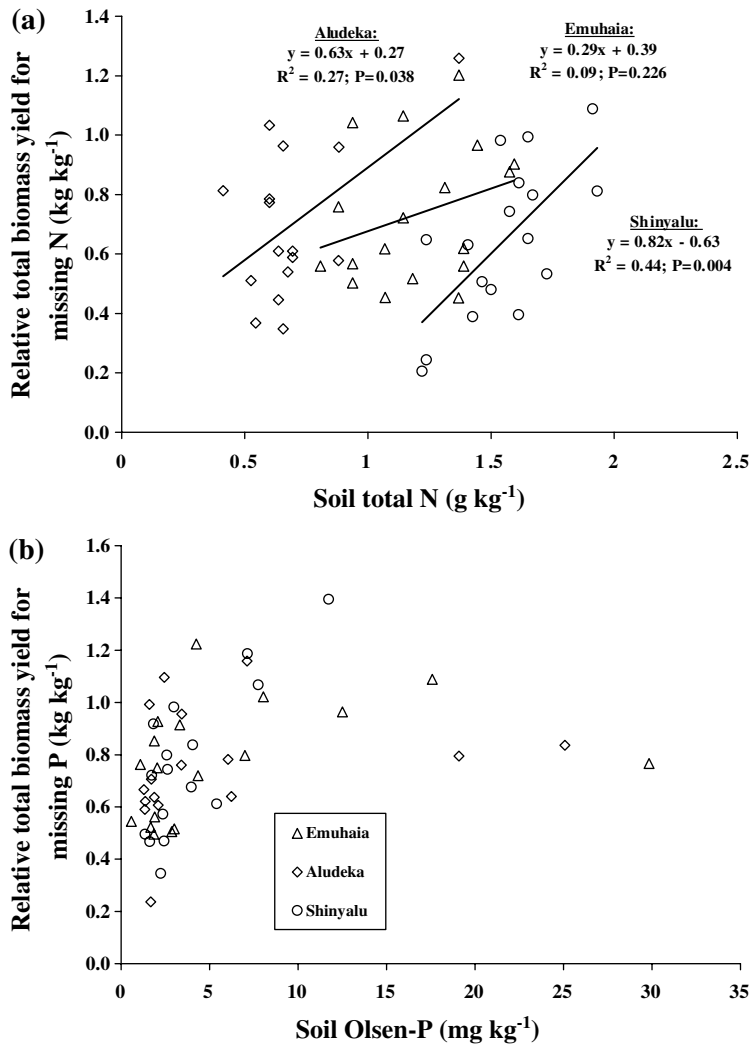

Figure 4. Relationships between relative yields without N and the initial soil total N content (a) and between the relative yields without P and the soil Olsen-P content (b). Y-axis values of 1 indicate no response to applied N or P fertiliser. The number of observations is 18 for Emuhaia (no missing values), 16 for Aludeka (2 missing values due to unrealistically low yields in the NPK treatment caused by within field variability), and 17 for Shinyalu (1 missing values due to crop failure caused by livestock browsing).

between N fertiliser recovery and the soil organic matter status of different fields at the two sites. While total recoveries of urea-N covered the same range in both areas (between 20 and 45%), in Benin, recovery of applied urea-N was positively related with soil organic C content while in Nigeria a negative relationship was observed. Although the reasons underlying these different trends were not clear, one could hypothesize that the major function of the soil organic matter pool in Benin was to alleviate one or more specific constraints to

crop growth besides N, while in Nigeria, soil organic matter supplied N to the growing crop, in competition with the N fertiliser applied. In the latter case, N released from the soil organic matter pool may be better synchronized with plant demand for N than applied fertiliser N.

Zooming in on the specific lack of available N, P, and K across the different field types, the following could be observed: (i) most fields responded to applied N and P fertiliser, (ii), in Aludeka and Shinyalu, the response to applied N tended to in-

crease with distance to the homestead (Figure 2a), and in Emuhaia and Shinyalu, this was also true for the response to applied P (Figure 2b), and (iii) response to applied K fertiliser was scarce at all sites, although not completely absent (Figure 2c). Shepherd et al. (1997) equally observed that N and P were the main limiting nutrients in food crop production in western Kenya. The increase in N response with distance from the homestead in Aludeka and Shinyalu, reflected in the decline in RY_N , was related to the decline in soil total N with distance from the homestead (Table 2, Figure 4a), although the relationship between both parameters only explained 27 to 44% of the variation. It is commonly known that total N or organic C are weak indicators for soil N availability although a wider range in soil total N values included usually results in a stronger correlation with crop yield (Carsky et al. 1998). The larger intercept for the Aludeka soils, compared with the Shinyalu soils (Figure 4a), reflected the higher soil clay and silt content in Shinyalu, resulting in stronger protection of the soil organic matter and lower N mineralisation potential (Vanlauwe et al. 2002b). The intermediate position of the Emuhaia points in Figure 4a reflects their intermediate clay and silt content and consequently intermediate protective capacity of the soil organic matter pool. The lack of correlation between crop dry matter production and soil total N content for the Emuhaia soils might be associated with the quality of the soil organic matter pool as the range in soil total N values between the close and the remote fields is similar (0.24 g kg^{-1}) as for the other two sites ($0.20\text{--}0.26 \text{ g kg}^{-1}$). In Emuhaia, relatively more organic inputs are used, mostly in the form of compost and/or animal manure (2.9 t ha^{-1} , averaged across all farm types – Tittonell et al. 2005a) than in Shinyalu (0.3 t ha^{-1}) or in Aludeka (0.0 t ha^{-1}), and application rates decrease with distance to the homestead (Tittonell et al. 2005b). Such organic resources have undergone a decomposition phase, either in the rumen of cattle and/or in a compost heap, and their N is usually less available than fresh organic resources of a similar biochemical quality (Vanlauwe et al. 2002c), which form the likely bulk of inputs in the other sites through crop residues (roots, cereal stover, etc). Consequently, the differences in total soil N values between the three field types may represent in fact smaller differences in soil available N, compared to

the other two sites, consequently resulting in less difference in response to N applied between the three field types.

Due to the high variability in Olsen-P of the close fields, differences in Olsen-P among fields within a farm varied widely at all sites, potentially masking some of the impacts of field type on P response. When considering all farms, in farms with relatively high Olsen-P gradients, clear differences in P response between fields were observed and close fields were observed to be non-responsive to P (Figure 3a). The relatively low RY_P values for the close fields in Emuhaia and Aludeka (Figure 2b) reflect the declining trend in RY_P for Olsen-P values ranging from 10 to 30 mg kg^{-1} (Figure 4b). The reasons behind this trend are not clear and could be related to the occurrence of limitations in nutrients that react with soil and/or fertiliser P, e.g., Zn. As for K, continuous cultivation and consequent extraction of available K from the soil reserves may induce K deficiencies in the medium to long term, especially in areas with relatively low base cation status. Shepherd et al. (1997) equally observed that N and P were the main limiting nutrients in food crop production in western Kenya, although K deficiencies were locally important.

Our findings highlight the need, in areas where management has induced often substantial differences in soil fertility status among fields, for site-specific fertiliser recommendations, especially in sub-Saharan Africa, where fertiliser is either relatively expensive and/or scarce. In Western Kenya (Kitale), for instance, transport costs nearly double the cost of one bag of di-ammonium phosphate to about 17 USD a bag (IFDC 2003). However, in order to formulate site-specific recommendations, it will be essential to base the diagnostic part on local soil quality assessment schemes, as formal soil analysis currently is beyond the financial reach of most small-scale farmers. Fortunately, farmers are often aware of within-farm soil fertility gradients and use local terms for the different soil quality levels of their fields. According to Murage et al. (2000) farmer's criteria for distinguishing productive and non-productive fields include crop performance, ease of tillage, soil moisture retention, soil colour and presence of weeds and soil invertebrates. Tittonell et al. (2005b) showed agreement between farmers classification and soil fertility status and maize yields; and management

intensity varied accordingly (e.g. planting date; fields with a higher fertility status were usually planted earlier than fields with lower fertility) from the fertile to the poor fields.

As farms in the target areas do contain fields with different soil fertility status and as this soil fertility status was shown to affect responses to applied fertiliser (mainly N and P), targeting of external inputs within this heterogeneity is a research question worth addressing. Due to the complexity of this question and the many potential combinations of management options, tools for evaluation of various scenarios will be required. An example of such farm-level modelling framework is the NUANCES (Nutrient Use in ANimal and Cropping systems – Efficiency and Scales) framework (Giller et al. 2005). The NUANCES modelling framework aims at analysing tradeoffs in technology adoption for mixed crop/livestock systems, which includes nutrients, labour and economic balances, and effects on environmental services. Scenarios could be evaluated under constant availability of resources, to assess whether alternative resource allocation strategies might result in enhanced resource use efficiency at the farm level, or under increased availability of resources, to derive optimum allocation strategies for these additional resources. The former exercise could be regarded as an evaluation of current farmer knowledge and practices while the latter exercise is likely to generate information beyond the current farmer knowledge.

Acknowledgements

We acknowledge the Bundesministerium für Wirtschaftliche Zusammenarbeit und Entwicklung (BMZ) for providing the necessary financial support in the framework of the project on 'Improving integrated nutrient management practices on small-scale farms in Africa'. We also thank Isaac Ekise (TSBF) and Walter Munyuere (Kenya Rural Extension Service) for their skilled assistance with the field activities. Helen Wangechi and Wilson Ngului are acknowledged for the laboratory analyses.

References

Anderson J.M. and Ingram J.S.I. 1993. *Tropical Soil Biology and Fertility: A Handbook of Methods*. CAB International, Wallingford, UK.

- Carsky R., Jagtap S.S., Tian G., Sanginga N. and Vanlauwe B. 1998. Maintenance of soil organic matter and N supply in the moist savanna zone of West Africa. In: Lal R. (eds). *Soil Quality and Agricultural Sustainability*. Ann Arbor Press, Chelsea, Michigan, pp. 223–236.
- Deckers J. 2002. A systems approach to target balanced nutrient management in soils of sub-Saharan Africa. In: Vanlauwe B., Diels J., Sanginga N. and Merckx R. (eds), *Integrated sub-Saharan Africa: From Concept to Practice*. CABI, Wallingford, UK, pp. 47–62.
- Dembélé I., Koné D., Soumaré A., Coulibaly D., Koné Y., Ly B. and Kater L. 2000. Fallows and field systems in dryland Mali. In: Hilhorst T. and Muchena F. (eds), *Nutrients on the Move. Soil Fertility Dynamics in African Farming Systems*. International Institute for Environment and Development, London, pp. 83–102.
- Giller K.E., Rowe E., de Ridder N. and van Keulen H. 2005. Resource use dynamics and interactions in the tropics: Scaling up in space and time. *Agric. Syst.* In press.
- IFDC 2003. An assessment of fertiliser prices in Kenya and Uganda: domestic prices vis-à-vis international market prices. IFDC Paper Series IFDC – PCD-27. IFDC, Muscle Shoals USA.
- Murage E.W., Karanja N.K., Smithson P.C. and Woome P.L. 2000. Diagnostic indicators of soil quality in productive and non-productive smallholders fields of Kenya's Central highlands. *Agric. Ecosyst. Environ.* 79: 1–8.
- Prudencio C.Y. 1993. Ring management of soils and crops in the west African semi-arid tropics: the case of the Mossi farming system in Burkina Faso. *Agric. Ecosyst. Environ.* 47: 237–264.
- SAS 1992. The MIXED procedure. SAS Technical Report P-229: SAS/STAT Software: Changes and Enhancements. SAS Institute Inc., Cary NC USA.
- Shepherd K.D. and Soule M.J. 1998. Soil fertility management in west Kenya: dynamic simulation of productivity, profitability and sustainability at different resource endowment levels. *Agric. Ecosyst. Environ.* 71: 131–145.
- Shepherd K.D., Ndufa J.K., Ohlsson E., Sjogren H. and Swinkels R. 1997. Adoption potential of hedgerow intercropping in maize-based cropping systems in the highlands of western Kenya. I. Background and agronomic evaluation. *Exp. Agric.* 33: 197–223.
- Smaling E.M.A., Stoorvogel J.J. and de Jager A. 2002. Decision making on integrated nutrient management through the eyes of the scientist, the land-user and the policy maker. In: Vanlauwe B., Diels J., Sanginga N. and Merckx R. (eds), *Integrated sub-Saharan Africa: From Concept to Practice*. CABI, Wallingford, UK, pp. 265–284.
- Tittonell P., Vanlauwe B., Leffelaar P.A., Rowe E. and Giller K.E. 2005a. Exploring diversity in soil fertility management of smallholder farms in western Kenya. I. Heterogeneity at region and farm scale. *Agric. Ecosyst. Environ.* In Press.
- Tittonell P., Vanlauwe B., Leffelaar P.A., Shepherd K.D. and Giller K.E. 2005b. Exploring diversity in soil fertility management of smallholder farms in western Kenya. II. Within-farm variability in resource allocation, nutrient flows and soil fertility status. *Agric. Ecosyst. Environ.* In press.
- Vanlauwe B., Nwoke O.C., Diels J., Sanginga N., Carsky R.J., Deckers J. and Merckx R. 2000. Utilization of rock phosphate

- by crops on a representative toposequence in the Northern Guinea savanna zone of Nigeria: response by *Mucuna pruriens*, *Lablab purpureus*, and maize. *Soil Biol. Biochem.* 32: 2063–2077.
- Vanlauwe B., Diels J., Sanginga N. and Merckx R. 2002a. Integrated Plant Nutrient Management in sub-Saharan Africa: From Concept to Practice. CABI, Wallingford, UK.
- Vanlauwe B., Diels J., Lyasse O., Aihou K., Iwuafor E.N.O., Sanginga N., Merckx R. and Deckers J. 2002b. Fertility status of soils of the derived savanna and northern guinea savanna and response to major plant nutrients, as influenced by soil type and land use management. *Nutr. Cycl. Agroecosyst.* 62: 139–150.
- Vanlauwe B., Palm C.A., Murwira H.K. and Merckx R. 2002c. Organic resource management in sub-Saharan Africa: validation of a residue quality-driven decision support system. *Agronomie* 22: 839–846.
- Vanlauwe B., Sanginga N., Giller K.E. and Merckx R. 2004. Management of nitrogen fertiliser in maize-based systems in subhumid areas of sub-Saharan Africa. In: Mosier A.R., Syers J.K. and Freney J.R. (eds), *Agriculture and the Nitrogen Cycle*. SCOPE Nr 65. Island Press, Washington, USA, pp. 115–127.
- Woomer P.L., Bekunda M.A., Karanja N.K., Moorehouse T. and Okalebo J.R. 1998. Agricultural resource management by smallholder farmers in East Africa. *Nat. Resour.* 34: 22–33.

Characterisation of soil degradation under intensive rice production in Office du Niger zone of Mali

Minamba Bagayoko¹, Mamadou K. N'Diaye², Mohamed Dicko¹ and Bréhima Tangara¹

¹ Institut d'Economie Rurale (IER) Centre de Recherche Agronomique de Niono, Pole Système Irrigué BP 12 Niono, Mali; ² Institut d'Economie Rurale (IER) Coordinateur Régional du Pole Système Irrigué BP 258 Bamako, Mali

Abstract

Food security is a major priority of the most Sahelian governments. With the cyclic droughts, irrigation has shown the potential of ensuring self sufficiency in food production. Unfortunately, soils of irrigated areas in Sub Sahara African countries have continued to be degraded as a result of poor irrigation management practices. In the “Office du Niger” zones, for example, producers and extension workers are concerned about emerging soil degradation symptoms such as salinisation/alkalinisation or sodisation. Whereas the above problems require urgent attention, the phenomenon has been treated as localised and therefore not very important. From 1995 to 1999, studies were conducted by “the Pole regional de recherche sur les Systèmes Irrigués (PSI)” which was a regional networking project, to determine the nature, importance and dynamics of soil degradation processes in irrigated zones of Mali

A piezometric network installed in the area revealed the impact of cropping systems and soil types on the evolution of water table in terms of dynamics and quality. The results clearly show evidence of soil geochemical changes and water management of the irrigated areas. The present paper highlights the research conducted to combat soil degradation in the irrigated rice system in the “Office du Niger” in Mali from 1995 to the present days.

Introduction

The context of irrigation in most Sub Sahara African countries is characterized by poor management practices that result in soil degradation. In general, irrigation results in many physical and biochemical changes in soil properties. These changes may be expressed in terms of salt balance in soil and water which may result in soil degradation. Soil salinity and sodicity are generally considered to be linked with water logging. However, survey at the geographical level generally shows that the causes of soil salinity are much more diverse.

In Mali, during the period between 1935 and 1965 some 55000 ha of irrigated land were developed in the “Delta Mort” of the River Niger. The irrigated areas were initially advocated for cotton production. Over the years a number of adverse conditions have become apparent: deterioration of infrastructure,

including irrigation and drainage channels and regulating devices; poor management of irrigation water supply, resulting in considerable over-irrigation; lack of a suitable outlet for the drainage water (the main outfall drain for the zones of Niono and N'Débougou (the “Kala Inférieur”) ends abruptly after some 60 km); high groundwater table throughout the irrigated areas. After the introduction of irrigation some 50 years ago, groundwater tables rose from a depth of some 30–40 meters to about land surface in a time span of some 20–30 years as a result of excessive irrigation applications and the lack of sufficient (natural and/or artificial) drainage facilities. Since 1970 with government policy changes, the irrigated areas of ON have been devoted mainly for rice production.

Water from the Niger River has long been considered as suitable for irrigation because of its low salt concentration. However, significant changes have occurred in the soil geochemical properties of irrigated

zones of ON during the last fifty years (PSI/CORAF, 1999; Toujan, 1980). Dabin (1951) noticed that the soils of Office du Niger were neutral or acid. He found that the soils had low sodium concentration and explained their low structural stability by the low calcium content at the exchange sites. Thirty five years later, Bertrand (1985) noticed that the soils had changed towards alcalinisation, salinisation and sodification and concluded that such a rapid evolution endangered the durability of irrigation systems in Mali. He emphasised the case of Dougabougou where sugar cane is the main crop. N'Diaye in 1987 confirmed Bertrand findings that sodification had occurred in most of the study sites. Sidibe (1987) found that alcalinisation and sodification were the main production constraints of sugar cane at Dougabougou and Siribala. Dicko and N'Diaye (1994), found that soils under vegetable crops were more affected than soils under rice production. N'Diaye et al. (1990) found a pH value of 8 and exchangeable sodium percentage (ESP) value greater than 10.

Salts in the soil solution are mainly introduced by irrigation or through capillary water rise and removed through leaching. The process by which the total salts concentrations increase due to evaporation and transpiration or to introduction of salts through irrigation or capillary rise is referred as salinisation. During this process divalent cations (Ca^{2+} and Mg^{2+}) remain dominant in the solution and there is no substitution of Ca^{2+} and Mg^{2+} on the complex exchange by Na^+ . The total concentration of salts in the soil solution is measured approximately by electrical conductivity of the saturated extract (EC_e in dS m^{-1}). The US salinity laboratory retains an EC_e value of 4 dS m^{-1} as a critical limit. Alkaline soils are generally characterised by pH values between 7.2 (moderately alkaline soils) and 10.5 (high alkaline soils). Sodification is the process by which divalent Ca^{2+} and Mg^{2+} on the complex are replaced by Na^+ ions when these ions become dominant in the soil solution. Generally sodium adsorption ratio (SAR) which is the root square of the ratio of sodium ions over divalent cations, is used as an indicator of water hazard. Critical values range between 3 when EC_e is 0.7 to 40 for EC_e of 5 dS m^{-1} .

Soil alkalinity is defined as the sum of all reactive ions in the soil susceptible to accept a proton. Calcite residual alkalinity (C-RA) is defined as:

$$\text{C-RA} = \text{Soil alkalinity} - 2\text{Ca}^{2+}$$

When C-RA is negative, that means there are more calcium ions in the soil solution. Therefore, its concentration will increase and the alkalinity will decrease. As a result, the soil will tend toward salinity. In contrast, when C-RA is positive, the soil will tend toward alkalinity because of calcium ions. While soil calcium concentration decreases, the portion of Sodium which does not participate to any precipitation reaction increases in soil solution leading to sodification

Materials and methods

Study site

The "Office du Niger" (ON) in Mali, which is located in the central delta of the River Niger was built by French engineers in 1932. Through the construction of a dam in the Niger river near Markala, old beds of the upper Niger (Fala de Molodo, Fala de Boky-Were) are used to supply water to all four zones (Kala superieur, Kala inferieur, Kouroumary and Macina) of the ON. The area is characterised by a very high evaporation rate, four months rainy season (with a yearly average of 460 mm) from June to September followed by eight months period of dry season occurring from October to May. The dry season is characterised by three months cool season (from mid-November to February) with minimum temperature around 20° and four months hot season during which maximum temperature is generally above 40° .

Methodology

From 1984 to 1999 studies were conducted in the ON zones to determine the cause effects relationships of soil degradation processes in Mali. To understand the mechanism of soil degradation phenomenon, water samples were taken the river and deep wells around the irrigated areas. Data were gathered at the levels of landscape, hydraulic channels (irrigation and drainage systems) and plots. To understand the ground water characteristics and the functioning of irrigation water, chemical and hydrodynamic parameters were measured on samples from randomly selected 221 deep wells covering the entire irrigated areas of ON. Survey and extensive sampling permitted the determination of salt distribution as a function of soil type, soil texture, water regime and cropping systems. Soil and water chemical analysis permitted the establishment of the

hydro-saline balance of the irrigation systems. Components measured were actual evaporation and transpiration rates of crops and the volume of water and salt incoming and outgoing through irrigation systems. To characterise the spatial and temporal variation of soil degradation, salinisation, alcalinisation and sodification indices were determined at the plot levels. Measurements concerned soil texture, pH, electrical conductivity on extract, hydraulic conductivity at saturation and soil density. A geo-statistical analysis allowed determination of the spatial structure of each parameter. Temporal changes of parameters were determined by comparison of areas differing in age and management practices.

Results and discussion

In many irrigated perimeters of the “Office du Niger”, signs of soil degradation through salinisation, alcalinisation and sodification zones were observed. These included apparition of visual characteristics such as the white and black efflorescence on soil surfaces. The visual characteristics of degradation were related to the results of soil sample analysis and indicated high pH values greater than 9 and exchangeable sodium percentage (ESP) values greater than 16%.

Areas affected by salinisation, alcalinisation and sodification

Survey at the village levels in Niono, Molodo and Kouroumari zones indicated high spatial variability in the problem of soil degradation through salinisation, alcalinisation and sodification (Table 1, 2 and Figure 1). In rice cultivated areas, the apparition of black and white efflorescence was generally related to soil types, surface topography and cropping systems. Keita et al. (1991), related Dabin’s vernacular soil classification

Table 1. Average salt affected areas in 5 villages of the Office du Niger (Barral and Dicko, 1996).

Villages	% of affected areas
Retail (new management site)	4.9
Retail (old management site)	3
Gruber	3.2
KL	6
KO	4.1

Table 2. Average salt affected areas in 3 zones of the Office du Niger (Barral and Dicko, 1996).

Irrigated zones	% of affected areas
Niono	4
Molodo	4.3
Kouroumari	3.2

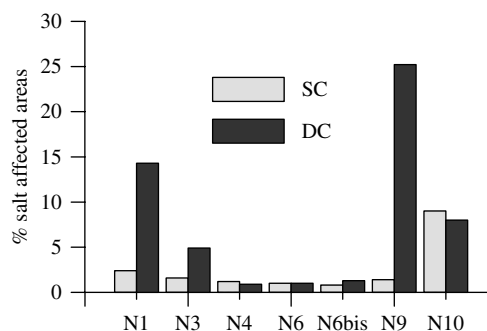

Figure 1. Percent salt affected areas in single (SC) and double (DC) rice cropping systems (Barral and Dicko, 1996).

to topographic conditions and noticed that in general soils of the depression zones (cuvettes) are predominantly Moursi and Dian while the soils on elevation (high levee or hills) are dominated by silt (Danga) or by silt and sand (Danga blé and Seno). It was generally observed that the elevated surfaces had more degradation problems than soils in depression zones. This is because when depression soils are submersed salts easily dissolved and leached out through irrigation and drainage water. In contrast, soils of high levee are in general not sufficiently flooded by irrigation water, but capillary water rise becomes more important when ground water level rises near soil surface. This causes salts to concentrate on top when evaporation becomes important.

Figure 1 shows that soils under double cropping systems were less affected than those cropped once within a year. This is certainly because in double cropping system, the soils are flooded during most of the year and this prevents salts from concentrating on the soil surface. Survey data indicated that 20% to 50% of soils cropped with vegetables were affected by salinisation and alcalinisation. This can be explained by capillary water rise and high evaporation rates under vegetable cropping systems.

Table 3. Analysis of water samples from the river Niger according to different authors (Van Diepen, 1984; N'Diaye, 1987 and Winja et al., 1994).

Literature Sources	Sampling sites and locations	pH	CE mmho/cm	Na ⁺ (meq/l)	Ca ⁺⁺ (meq/l)	Mg ⁺⁺ (meq/l)	K ⁺ (meq/l)	HCO ₃ ⁻⁻⁻ (meq/l)	SO ₄ ⁻⁻ (meq/l)	PO ₄ ⁻⁻⁻ (meq/l)	Cl ⁻ (meq/l)	SAR	Alc Calcite Residual
Van Diepen	N12g (Niono)	7.63	0.100	0.480	0.300	0.180	0.060	0.980	0.005	0.004	0.002	0.980	0.680
Van Diepen	K5 (Macina)	7.06	0.060	0.210	0.200	0.160	0.050	0.550	0.005	0.004	0.002	0.460	0.350
N'Diaye	K7 (Kourimary)	6.95	0.035	0.130	0.130	0.120	0.030	0.420	< 0.010	0.000	0.010	0.370	0.290
N'Diaye	K7 (Kourimary)	6.7	0.036	0.130	0.140	0.130	0.020	0.440	< 0.010	0.000	0.020	0.350	0.300
Wijnja	N4Lg (Niono ^o)	7.2	0.100	0.190	0.120	0.130	0.050	0.500	0.000	0.000	0.000	0.530	0.380

River "Niger" water quality

Experimental data from various studies (Table 3) showed that irrigation water coming from the River Niger has very low salt concentration and pH values near neutrality. Ions with relatively higher values are Na⁺, Ca²⁺, Mg²⁺, and HCO₃⁻. All samples had predominantly higher values as compares to other ions. Also, all samples had positive residual alkalinity. According to Richards (1954) irrigating soils with such low concentrations presents no risk of salinisation or sodification.

Salt levels of ground water

Chemical analysis of ground water (Table 4) after different studies showed that pH values were more than a

unit greater than that of irrigation water (Table 3). As results when water rises through capillarity, evaporation will cause the salts to concentrate gradually on soil surface. This may lead to precipitation of CaCO₃ thus cause a relative enrichment in Na⁺ which in turn will result in high pH (leading to soil alkalinity) and high exchangeable sodium percentage (ESP) leading to soil sodicity (Bertrand, 1985).

Dynamic of water table

Before irrigation, ground water levels in the ON zones varied between 30 m and 70 m depth. Surveys at the geographical levels indicated that since the beginning of irrigation, the levels of ground water had risen toward soil surface. Seasonal water variation at the plot levels caused ground water to rise up to only two meters from

Table 4. Analysis of water samples from deep wells according to different authors (Soviet mission (1964) cited by Toujan (1980); N'Diaye, 1987 and Winja, 1993).

Samples variables	Sources					
	Soviet mission(8 wells)	Van Diepen G (km26)	N'Diaye	N'Diaye	Winja KL3	Winja G5
pH		8.17	8.24	8.3	7.6	8.1
CE mmho/cm		0.850	1.10	0.74	0.5	1.98
Na ⁺ (meq/l)	5.060	7.300	12.61	5.46	3.1	16.53
Ca ⁺⁺ (meq/l)	3.540	0.820	0.74	3.18	1.7	1.5
Mg ⁺⁺ (meq/l)	1.550	1.180	0.58	1.00	0.7	1.8
K ⁺ (meq/l)		0.030	0.02	0.08	5.60.1	0.04
HCO ₃ ⁻⁻⁻ (meq/l)	7.560	8.050	12.76	8.32	0.25.6	16.77
SO ₄ ⁻⁻ (meq/l)	0.090	0.230	1.43	0.57	0.00.2	2.32
PO ₄ ⁻⁻⁻ (meq/l)		0.010	0.00	0.00	0.0	0.06
Cl ⁻ (meq/l)	0.930	0.430	0.71	0.54		3.6
SAR	3.100	7.300	15.5	3.80	2.9	12.87

the soil surface when crops were irrigated. Data from piezometric net work installed throughout the region indicated that soil water dynamic was largely influenced by cropping systems. When crops were irrigated, water rose rapidly near the surface during the mid season. The levels stabilised during the maximum growth stage and then declined at harvest from November until June. Outside the plots, groundwater levels followed the rhythm of irrigation water flow in the irrigation canals.

Drainage

Causes for the high water levels in the outfall channels were identified as:

- Insufficient extension of the main channel. As observed the outfall channel of the Niono-N'Débougou zones ended abruptly after some 60 km. This situation was not likely to change in the foreseeable future
- Wastage of irrigation water, which continued even in rehabilitated areas. The situation was, however, expected to improve as a result of the planned training programmes for irrigation operators
- The outfall channel was also being used as a source of irrigation water by farmers who occupy lands outside the official irrigation schemes (“hors casiers”). In order to irrigate their land by gravity, the farmers raised the water level in the outfall channel by means of makeshift barriers (illegal but tolerated). Reliable figures could not be obtained, but it was said that in the order of 10,000 ha of rice growing “hors casiers” was fully dependant on drainage water of the Niono-N'Débougou schemes.

Given the nature of the field drains (shallow, widely spaced “rigoles”), the function of the existing drainage networks is practically limited to surface drainage; it will hardly allow for any significant percolation/leaching. There may, however, be some natural subsurface drainage due to the fact that in the irrigated areas the groundwater table was approximately at land surface, whereas at a distance of some 20 km it was at a depth of some 40 m. Thus there exists a hydraulic gradient which, in principle, would cause some groundwater flow. Estimates made for natural drainage varied between some 0.5% and 2.5% of the amount of irrigation water applied.

Table 5. Salt balance at plot levels in village N 4 in Niono zone (Barral, 1997).

Village N4-1g	Water losses	Irrigation water	Salt balance
EC (dS m ⁻¹)	0.4	0.045	
Water (mm)	160	820	
T ha ⁻¹ salt	0.42	0.24	-0.18

Table 6. Salt balance at plot levels in village N 9 in Niono zone (Barral, 1997).

Plot	Variables	Water losses	Irrigation water	Salt balance
P9	EC (dS m ⁻¹)	1	0.045	
	Water (mm)	130	850	
	T ha ⁻¹ salt	0.8	0.25	0.6
P10	EC (dS m ⁻¹)	0.2	0.045	
	Water (mm)	40	640	
	T ha ⁻¹ salt	0.05	0.29	0.24

Water and salt balances at irrigated plot levels

Salt balance for N4 and N6 villages at Niono zone are presented in Tables 5 and 6. Accumulation of salts under irrigation depends on soil type and soil drainage conditions. On well drainage soils, salts accumulated on soil surface through capillary rise are quickly dissolved when the plots are submersed by irrigation water and leached out with drainage water. However, salt balance of low level and depression soils which are generally dominated by silt and clay, may be positive or negative depending on drainage conditions.

Causes of soil degradation

The dysfunctioning of irrigation system appear to be driving factor that contributes to soil degradation in Mali. This is in particular related to poor drainage conditions and poor water use efficiency. Further, the high evaporation rates and the ionic composition of the Niger River water (comparatively high in Na⁺ and HCO₃⁻) could also be playing a major role in enhancing soil degradation in the region.

As a result, the shallow ground water will gradually become more concentrated, which may lead to precipitation of CaCO₃ and thus a relative enrichment in Na⁺, which in turn results in a high pH (alkalinity) and a high ESP of the soil.

Contrary to salinisation, alcalinisation/sodification develops slowly, but once it has developed, the cure is difficult, time consuming and costly.

Conclusion

Considering the overall water balance of the entire region, it can be concluded that the dysfunctioning of irrigation system is the driving factor that contribute to soil degradation in Mali. The high salt concentration of groundwater, the poor drainage conditions lead to poor water use efficiency of crops. Capillary water rise and the ionic composition of the Niger River water (comparatively high in Na^+ and HCO_3^-) contribute to accumulation of salts on soil surface and deterioration of soil structure. There is more concern about sodicity/alkalinity than salinity. At present, soil alcalinisation and sodification have not significantly affected average rice paddy yields because of improvement in cultural practices such as shift in rice transplanting technique, pest management and improvement in fertiliser applications.

References

- Barral J.P. and Dicko M. 1996. La dégradation des sols à l'Office du Niger, synthèse bibliographique. Travaux et étude n° 1, PSI-Mali.
- Barral J.P., Marlet S., N'Diaye M.K., Valenza A., Dicko M., Tangara B. et Grillot J.C. 1996. Fonctionnement des nappes en relation avec la dégradation des sols à l'Office du Niger, synthèse bibliographique. Travaux et étude n° 2, PSI-Mali.
- Barral J.P. 1997. Rapport d'activités, 1996-97. Evolution des sols sous irrigation à l'Office du Niger. La gestion de l'eau sur les périmètres de l'Office du Niger, IER/PSI Mali. Travaux et étude n° 3, PSI-Mali.
- Bertrand R. 1985. Sodisation et alcalinisation des sols de l'Office du Niger (Mali), CIRAD-IRAT, 25 P.
- Dicko M. and N'Diaye M.K. 1994. Rapport volet Salinisation. Caractérisation des sols irrigués, IER, Bamako, 59p. (this is an annual report).
- Keita B., Koukandji B. et Dioni L. 1991. Etude morphopédologique du Kala inférieur (1/20000) rapport et carte, IER.
- N'Diaye M.K. 1987. Evaluation de la fertilité des sols à l'Office du Niger (Mali), contribution à la recherche des causes et origines de la dégradation des sols dans le Kouroumari. Thèse de docteur ingénieur, INP Toulouse. 133p.
- N'Diaye M.K., Guindo D. Dicko M. 1994. Caractérisation des processus de salinisation en zone Office du Niger, CRRAN, Niono, (1994 annual report).
- PSI/CORAF. 1999. Pour un développement durable de l'agriculture irriguée dans la zone Soudano-Sahélienne. Acte du Séminaire Dakar (Sénégal) du 30, pveùbre ai 3 décembre 1999.
- Toujan M. 1980. Aménagement hydroagricole dépendant du canal du Sahel. Evolution des sols irrigués, Office du Niger SOGREHA, Ségou.
- Richards L.A. 1954. Diagnosis and improvement of saline and alkali soils. USDA Agricultural handbook 60. Washington DC USA.
- Sidibe N. 1987. Contraintes pédologiques à la production de la canne à sucre dans le périmètre de Dougabougou. Thèse INA. 150 p.
- Van Diepen C. 1984. Les sols irrigués des casiers rizicoles de l'Office du Niger, ARPON, Ségou.

Soil fertility issues in the Blue Nile Valley, Ethiopia

Per Ivar Våje

Jordforsk, Norwegian Centre for Soil and Environmental Research; Frederik A. Dahls vei 20, 1432 Ås, Norway,
E-mail: perivav@frisurf.no

Abstract

The Gumuz people in Ethiopia is a minority group with a population of about 100,000 in Ethiopia. Most of them live in the Blue Nile valley. They traditionally practice shifting cultivation and lead semi-nomadic lives, settling for four to five years before moving on to clear new land. Population increase and more permanent settlements have led to increasing pressure on available land, shorter cultivation-fallow cycles and widespread soil fertility decline. The introduction of striga (*Striga* spp.) further exacerbates the situation. Forests, bushland and grasslands are burned annually to clear the land, thus removing valuable organic matter from the ecosystem. Nutrients in the ash are to some extent lost through runoff and erosion. Efforts are being made through Agallo Meti Sirba Community Development Project (ASCDP) to contain and reverse the situation. The project is run by the Ethiopian Evangelical Church Mekane Yesus, with cooperation and funds from NORAD and The Norwegian Missionary Society (NMS). This paper is based on results and field observations during the period September 2001 to February 2003, focusing on current trends in soil fertility, making recommendations on what should be done to reverse the general decline in soil fertility and to ensure agricultural sustainability in the area.

Key words: Soil fertility, Blue-Nile valley, Ethiopia, slash- and burn, sustainable agriculture, rural development

Introduction

Soil fertility degradation has been described as the single most important constraint to food security in Sub-Saharan Africa (SSA) (World Bank 1996). Nandwa (2003) classified Ethiopia as having a high nutrient depletion rate of more than 60 kg N, P, and K ha⁻¹ yr⁻¹. However there are great variations within SSA and within regions in a country. Most work on soil fertility decline in Ethiopia has been done at higher elevations (Bezuayehu et al. 2000; Mekonnen, 2003; Olana 2003). Therefore there is a need to conduct site specific research and surveys on soil fertility dynamics in lower elevations of the country. Soil fertility decline is not just a problem of soil nutrient deficiency (Bationo 2004), it also depends on other factors including cropping systems, pest and diseases, poverty, population growth, national and global policies and institutional structures.

To address this problem effectively, a holistic approach is required when addressing the causes, consequences and designing management strategies for combating soil fertility decline. The Gumuz people in the Blue Nile Valley are traditionally semi-nomadic, moving to a new settlement every 4–5 years to clear new land for crop production. The prevalent practice of slash- and burn-agriculture, combined with population increase and a shift to more permanent settlements, makes soil fertility management and agricultural sustainability a challenge. The work presented in this paper attempts to address the above issues and is based on research, observations and reflections during a 16 month period among the Gumuz people in Agallo Meti and Sirba. The author worked in this period as an agricultural advisor within an integrated rural development project run by the development section under the Ethiopian Evangelical Church Mekane Yesus (EECMY).

Materials and methods

This study was conducted in Agallo Meti (930 masl) and Sirba (600 masl) Woredas in the Kamashi administrative Zone of Region 4, Western Ethiopia. The area lies within the Blue-Nile Valley which forms a wide depression about 1,000 m below the surrounding Ethiopian highlands. The predominant vegetation consists of forest and bush land with patches of agricultural fields and settlements in between. Common and valued tree-species in the area are lowland bamboo (*Oxytenanthera Abyssinica*) *Cordia Africana* and *Ficus Sycomorus* in Agallo Meti, and *Ziziphus Spinachristi* and *Boswellia Papyrifera* in Sirba. Grasses grow vigorously during the rainy season and reach a size of up to 3–4 m some places.

Current agricultural practice

The Gumuz people is a minority group in Ethiopia, with a population of approximately 100,000 living in region 4 of Ethiopia. Their language, culture and way of life are very different from their neighbours in the surrounding Ethiopian highlands. Their staple food is made from sorghum (*Sorghum bicolor* Moench), supplemented by maize (*Zea mays* L.), beans (*Phaseolus vulgaris* L.) sesame (*Sesamum indicum*), groundnuts (*Arachis hypogaea* L.), and roots and leaves from the forest. Some fruit and vegetables are grown in the area or bought at the local market. Sesame, cotton (*Gossypium hirsutum* L.) and groundnut are important cash crops. Livestock includes goats and sheep, however poultry and cattle-keeping are also increasing due to immigration of neighbouring tribes from the highlands and improved veterinary services.

Traditional cropping methods are done manually, with no inputs of mineral fertilizers or irrigation, instead moving corals with cattle manure are used wherever possible to partly sustain soil productivity on some fields. Land is cleared by fire during the dry season, burning the area surrounding the houses first. Some trees are cut down to avoid shading and competition for water, while those left survive the burning and regenerate naturally. Sorghum-fields are sown at the onset of the rains by planting 5–10 seeds per hole made using a single stroke of a hand hoe. The crops are weeded 3–6 weeks after sowing and it is the only additional work done in the field prior to harvesting. Local varieties of climbing beans often climb on remaining dead trunks in the field. Fields are also burned every year between the

cropping seasons to remove weeds and plant residues. The cropping phase for sorghum may last for 4–5 years depending on yields and available land, before the fields are left under fallow. Cotton and sesame are sometimes grown in rotation with sorghum, before a new fallow period. Maize, beans and some vegetables are normally grown on fields closer to the settlements.

Climate and soils

Daily rainfall and temperature data were collected more or less continuously from July 1998 in Agallo Meti and from 1996 in Sirba. The average daily temperature ranges from 25 to 32°C in Sirba and 20 to 30°C in Agallo Meti (Figure 1). Annual precipitation is about 1,000 mm and 1,500 mm at Sirba and Agallo Meti, respectively. Rainfall is unimodal, with the wet season running from April to October, and about four weeks shorter in Sirba.

Composite topsoil samples were collected from different fields, representing a variety of arable land in Agallo Meti (1998–2001), and from one field only in Sirba (2002). Samples were analysed at the National Soil Research Centre under the Ethiopian Agricultural Research Organization (EARO), using their standard methods. Samples in 1998 were taken from the top 15 cm, while all other samples from the top 20 cm. The samples collected in 1998 were from a farmers field, after one (98/1) and four (98/2) years of cropping a previously bush-fallowed and fire-cleared land. A variety of demonstration plots were sampled in 1999 (Table 1). Sample 99/1 and 99/2 were taken from the first demonstration plot just outside the compound. This plot was used for different crops and management practices from 1996 and onwards. Sample 99/3 was collected from a sloping and stony sorghum field, but different varieties of maize were also tested. A nursery (99/4) and banana (*Musa* spp.) field (99/5) were also sampled. In 2001, samples were collected from fallow land at different locations (Table 1). The field of 01/1 was cleared and used for testing out about 40 different tree species. Sample 01/ 3 came from a field in a nearby village. This field was cleared in 2002 and used as a local nursery.

Project activities for research and development

The Agallo Meti-Sirba Community Development Project (ASCDP) was launched in 1995 to address

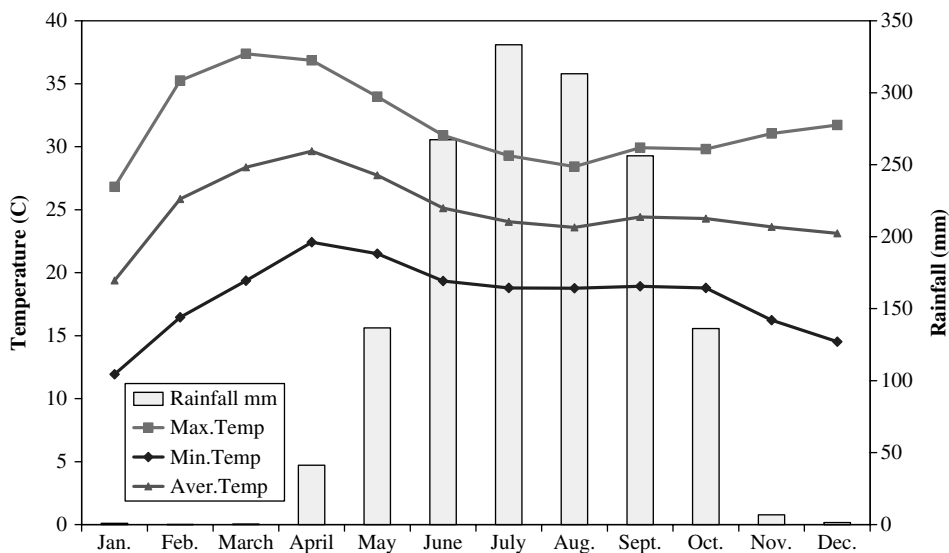

Figure 1a. Monthly rainfall and temperature in Agallo Meti, average over four years (1999–2002).

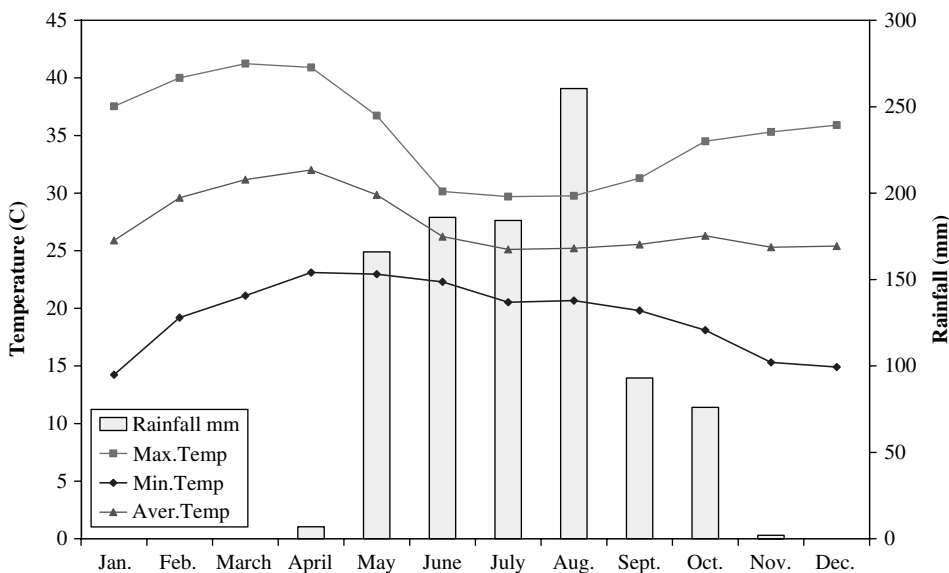

Figure 1b. Monthly rainfall and temperature in Sirba, average over five years (1996–2000). Dataset is not complete for all months.

problems such as high child mortality, decreasing yields, lack of clean drinking water and an illiteracy-rate of 85–98%. Agricultural improvements have been an integrated part of the project. The project activities have aimed at increasing crop yield per ha, diversify the number of crops produced, with due consideration of soil fertility and agricultural sustainability. A number of legumes, tubers, vegetables, grain crops and about 40 different multi-purpose trees were tested.

Demonstration plots were established with intercropping of maize and legumes and alley cropping with pigeon pea (*Cajanus Cajan*), *leucaena Leucocephala* and *Sesbania Sesban*. Twenty maize varieties were tested of which eight were local cultivars, and 12 were brought from Malkassa and Bako research stations.

In 2002, two trials were established in Agallo Meti with eight and nine maize and sorghum varieties, respectively. The design was a split block with 5 (4)

Table 1. Location and identification of demonstration plots for soil sampling 1998–2002.

Sample	Site	Location	Identification
98/1	Agallo Meti	Farmers field, deep soil	One year of cropping after clearing
98/2	—“—	—“—	Four years of cropping after clearing
99/1	—“—	Demo-field near compound	Sweet potato-1999. Maize, Rep.2-2002
99/2	—“—	—“—	Sorghum-1999. Maize, Rep.3-2002
99/3	—“—	Farmers field, shallow soil	Sloping field, many stones
99/4	—“—	Riverbank, small creek	Nursery for trees and vegetables
99/5	—“—	—“—	Banana field
01/1	—“—	Nearby the airstrip	Testing of trees. Need drainage
01/2	—“—	Outside the compound	Sorghum field in 2002
01/3	Denda Ate	2 hrs. walk from Agallo M.	Field with spring water all year
02/1	Sirba	Riverbank, Boka river	Nursery
02/2	—“—	—“—	—“—
02/3	—“—	—“—	Banana field

treatments and 3 replicates. Plot size was 2.5×2.25 m the spacing was 75 cm \times 20 cm for sorghum and early varieties of maize, and 75 cm \times 40 cm for late varieties, whereby two seeds were sown in each hole. Maize was thinned after three weeks to achieve 18 plants per plot (3.2 plants m^{-2}) for late varieties and 33 plants per plot (5.9 plants m^{-2}) for early varieties. Sorghum was not thinned due to very poor emergence for several varieties.

The treatments were:

- I. Traditional (minimum tillage, no fertilizer)
- II. As I, but with extensive hand hoeing, or oxen ploughing
- III. As II, but with mineral fertilizer: 100 kg diammonium phosphate (DAP) and 100 kg Urea ha^{-1} . Urea was applied in two equal applications at sowing and when the plants were at knee height.
- IV. As II but with goat manure: 2 kg m^{-2} (about 60 kg N ha^{-1}) manure is mixed with topsoil prior to sowing.
- V. As II, but with compost – 3 months old (made from grass, mango leaves, bamboo, sisal and some ash and donkey manure): One topped bucket was added to each plot and mixed with the soil, in addition to one handful applied to each hole at sowing.

Results and discussion

Soil properties

Results of soil analysis illustrated the soil variability and effects of different management practices. The samples from the farmers field in 1998 indicate a clay soil with a decrease in total N (2.1 – 1.9 g kg^{-1}), SOC

(25.7 – 22.7 g kg^{-1}) and available P (6.6 – 3.3 mg kg^{-1}), with time of cropping since clearing new land (98/1–98/2, Table 2). A similar declining trend was found for other parameters like Na, K, Ca, Mg and CEC (Table 3) after four years of continuous cropping. These trends indicate a situation with negative nutrient flow where export from the farm/plots is higher than what is added to the plots/farms. (Nandwa, 2003).

Sample 99/1 and 99/2 were sampled from the same field with the exact same texture (Table 2). Still sample 99/1 had more P (7.4 vs. 4.4 mg kg^{-1}) and K (0.94 vs. 0.42 g kg^{-1}) than 99/2, which illustrates large soil variability over short distances. The sorghum-field with the stony clay loam soil (99/3) had the lowest P value of all samples (2.5 mg kg^{-1}), and was found to be unsuitable for maize. The banana field by the river (99/5) had the highest level of P (9.3 mg kg^{-1}) and total N (2.9 g kg^{-1}) compared to all other samples, most probably due to deposition of sediments and ash from runoff upstream when the field is flooded during heavy rains. Due to their location near the river, the soil in this field and the nursery (99/4) were sandier than those of the other sites, and classified as sandy clay loam. This field will also remain moist throughout the dry season due to the river and shading of trees. All samples collected in 1999 had lower base saturation (60–72 %), CEC (26–28%) and concentrations of Na, K and Ca than the sample taken one year after burning (Agallo 98/1, Table 3). This also indicates a general loss of soil fertility with continuous cultivation.

Samples from fallow plots in 2001 (01/1, 01/2, 01/3) had higher contents of SOC (> 40.9 g kg^{-1}) than the other samples, illustrating the accumulation of SOC during a fallow period. This further implies a potential loss of SOC after clearing and burning. Sample 01/1

Table 2. Some soil parameters of samples from Agallo Meti and Sirba, collected 1998–2002.

Sample	pH H ₂ O 1:2.5	Sand %	Silt	Clay	TN g kg ⁻¹	SOC	C/N - ratio	Avail. P mg kg ⁻¹
Agallo 98/1	6.6	30	28	42	2.1	25.7	12.0	6.6
Agallo 98/2	6.3	36	24	40	1.9	22.7	12.0	3.3
Agallo 99/1	6.1	35	22	43	1.9	22.7	12.0	7.4
Agallo 99/2	6.4	35	22	43	1.8	22.3	12.3	4.4
Agallo 99/3	6.3	39	26	35	2.1	27.7	13.2	2.5
Agallo 99/4	6.3	47	24	29	2.5	28.9	11.8	5.5
Agallo 99/5	5.7	49	22	29	2.9	31.9	10.9	9.3
Agallo 01/1	6.4	30	34	36	2.5	41.5	16.3	7.0
Agallo 01/2	6.2	24	42	34	2.5	40.9	16.7	5.8
Agallo 01/3	5.8	28	30	42	2.9	43.9	15.3	5.8
Sirba 02/1	7.5	56	28	16	1.3	11.7	9.1	7.0
Sirba 02/2	8.0	56	32	12	1.1	12.0	11.0	8.4
Sirba 02/3	7.8	62	26	12	1.2	14.1	11.5	7.6

Table 3. Some soil parameters of samples from Agallo Meti and Sirba, collected 1998–2002.

Sample	Na cmol kg ⁻¹	K	Mg	Ca	Sum cmol kg ⁻¹	CEC %	Base sat. %
Agallo 98/1	0.55	0.94	5.91	30.3	37.7	39.5	95
Agallo 98/2	0.31	0.67	4.66	24.4	30.0	31.6	95
Agallo 99/1	0.31	0.92	4.92	9.8	16.0	26.6	60
Agallo 99/2	0.23	0.42	4.67	12.8	18.1	26.4	68
Agallo 99/3	0.23	0.25	6.25	12.6	19.3	28.4	68
Agallo 99/4	0.23	0.25	4.58	11.3	16.4	27.0	60
Agallo 99/5	0.23	0.57	6.00	13.1	19.9	27.6	72
Sirba 02/1	0.25	0.07	2.72	12.7	15.8	13.1	NA
Sirba 02/2	0.26	0.10	1.15	13.7	15.2	12.9	NA
Sirba 02/3	0.27	0.12	1.23	13.5	15.1	12.9	NA

and 01/2, were a clay loam, while 01/3 were a pure clay soil. The total N, SOC, K and Mg levels for the soil samples from Sirba (0.1 and 1.2–2.7 cmol kg⁻¹, respectively) were much lower than for samples from Agallo (0.2–0.9 and 4.5–6.0 cmol kg⁻¹, respectively). The pH varied from 5.7 to 6.6 in samples from Agallo, compared to 7.5 to 8.0 for the soil samples from Sirba. Also total N (1.1–1.3 g kg⁻¹) and SOC (11.7 and 14.1 g kg⁻¹) was much lower for this soil than for samples from Agallo Meti (1.8–2.9 and 22.3–43.9 g kg⁻¹ respectively). The soils from the riverbank of the relatively large Boka River in Sirba were loam and sandy loam, with less clay and more sand than all samples from Agallo Meti (Table 2).

Demonstration plots and trials

Some vegetables (onions, tomatoes, sweet pepper, water melon, and certain varieties of cabbage) and

fruit trees adapted well to different site conditions both climatically and culturally. Among fruit trees mango (*Mangifera indica*), papaya (*Carica papaya*), banana, and to some extent orange (*Citrus sinensis*), have been adopted by the local people. Establishment of group nurseries where water is available throughout the dry season, have proven very successful for vegetable and fruit production.

Results presented in Table 4 show no significant differences ($P < 0.05$) among maize varieties. The BH varieties are hybrids from Bako research station, while the others are open pollinated. The hybrid “BHQP 542” performed very well in 2002, and may contribute substantially to improving the nutritional status of the area due to its high content of well balanced amino-acids. The major limitation with hybrid maize is that it requires new seeds every year which are not always available in the area. The open pollinated varieties are more likely to succeed because farmers can save seeds to plant next season. The earlymaturing varieties

Table 4. Results from maize-trials in Agallo Meti in 2002, average over three replications.

Varieties	Manure	Compost	Trad.+ plough	Trad.	Average
Weight of cobs in tons ha ⁻¹					
Malkassa	9.60	8.89	9.01	7.35	8.71
Katumani	10.19	9.96	8.89	8.77	9.45
Agallo	11.02	9.78	10.19	8.77	9.94
Obatampa	10.96	10.49	10.19	7.29	9.73
Gibe-1	11.91	12.15	10.90	8.83	10.95
BHQP 542	10.13	11.02	10.61	8.65	10.10
BH 530	8.77	9.90	8.83	6.70	8.55
BH 540	10.61	9.78	9.42	8.83	9.66
BH 140	8.00	8.18	7.47	6.16	7.45
Average:	10.13	10.01	9.50	7.93	9.39

(Malkassa and Katumani) are promising because they can provide fresh maize for consumption at a time of the year when food is scarce and also a second crop preferably a legume can be grown after harvesting.

No yield benefits were found for newly introduced sorghum varieties. On the contrary, the local variety had several qualities as compared to the new varieties tested. Early maturing sorghum varieties may be useful for late planting especially if the crop has failed at the beginning of the season. One of the major problems with planting early- and late-maturing varieties at the same time is that the seeds/grain of the former will be eaten by birds. Secondly early maturing varieties are damaged by goats because of their short and weak stems. The local variety is late maturing and grows very tall (3–4 m), making it strong

against attack by birds and goats. It is not greatly affected by Striga because of its vigorous growth. It also proved to be highly drought tolerant and produced more tillers (1–4 from each seed) compared to only 1 for other varieties. This multiplying ability was not known by the local farmer since they normally put an unknown number of seeds in each hole at planting. It remains to be tested if this effect was triggered by the drought stress during emergence, or if this is a varietal characteristic.

Trials with maize have shown a substantial yield increase with manure as well as mineral fertilizer for all the years these trials have been conducted. (Figure 2). Traditional cropping without tillage and fertility inputs gave the lowest yields. Ploughing alone significantly ($P < 0.05$) improved the average maize yield in

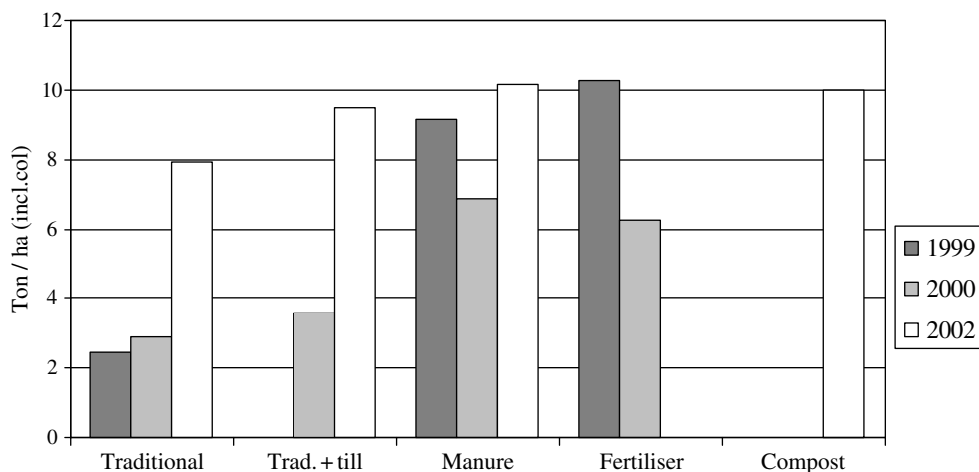

Figure 2. Comparison of results of maize yields from three years and different treatments.

2002 from 7.9 to 9.5 t ha⁻¹ (Table 3). Ploughing and adding either manure or compost also resulted in significantly higher yield in 2002 (10.1 and 10.0 t ha⁻¹, $P < 0.05$). However, there was no significant difference among the three best treatments. Mineral fertilizer is not an option for most farmers due to the high costs and risks involved. Farmers however may afford buying fertilizer if they organise themselves since there is a strong tradition of group efforts amongst the Gumuz people. The use of inorganic fertilizers is an option for remote fields where manure and compost use is unpractical due to transport difficulties. Animal manure is available in increasing quantities, yet it is not considered a resource for soil fertility improvement. Plant materials for composting are abundant, and it could easily be prepared in the rainy season when there is enough moisture, the quality can be improved by adding small amounts of animal manure or ash during composting. The compost should preferably be available at the onset of the rainy season. The main limiting factor for the adoption of composting techniques is that they are too laborious, making it more applicable to small home-gardens with vegetables. Hence utilizing plant residues in-field, is more applicable.

The reason for the positive effect of ploughing on yields may be both physical and chemical, related to water as well as nutrients. Softening and mixing the soil provides a better environment for root growth and improve infiltration of rainfall. This enables the young plants to survive the early drought. Incorporating ash and plant residues into the soil lead to improved soil structure and availability of nutrients that otherwise may be lost through wind or water erosion. Furthermore, ploughing increases mineralization of soil organic matter due to improved aeration. This will give increased nutrient availability and yields in the short run, but may prove to be negative in the long run as reserves of soil organic matter decrease. There is much evidence for rapid decline in SOC levels with continuous cultivation in sub-Saharan Africa (Bationo et al. 1995; Kapkiyai et al. 1997), and ploughing of previously untilled soil accelerates this process. Ox-ploughing is not a traditional practice among the Gumuz population, however, it is getting increasingly popular due to the influx of settlers from the highland introducing the practice. Ox-ploughing saves labour, which is a limiting factor for the agricultural system. It is also promoted by the ASCDP through training farmers and by renting out oxen for ploughing.

The importance of grass burning

Grass burning is a traditional and essential management tool for the Gumuz population, and cannot be ignored when considering possible improvements in the agricultural cropping systems. Farmers have several reasons for grass-burning which reach far beyond the agricultural sector (Figure 3a). It has been reported as the most effective way to manage pastures with low stocking rates, large areas and low capital and labour inputs (Pyne 1995; 1997). The grasses commonly reach 3–4 m in height and are 7–8 mm thick at the base, forming an almost impermeable thicket, making burning essential. Burning also ensures grass dominance, and avoids bush encroachment (Kull 2002). Burning ensures immediate regeneration of new fresh grasses that are easily digested by ruminants, even during the dry season. It also overrides the competitive effects of selective grazing, giving favoured forage species a better chance (Kull 2000). The increased grazing pressure due to more cattle may reduce the need of grass burning as a way of clearing the land, but forage quality may be reduced, and overgrazing will worsen the situation of soil fertility decline and increased soil erosion. Burning reduces problems with pests, snakes, scorpions and wild animals. It also is a traditional way of hunting by scaring animals into the open. Finally it reduces plant residues that would otherwise make sowing more difficult, and even produce ash that give a short-term soil fertility improvement.

From a soil fertility perspective, there are several effects of grass burning (Figure 3b).

Organic C along with N and S is lost to the atmosphere. Other nutrients may also be lost through volatilization and as ash particles (Cook 1994; Pivello and Coutinho 1992; Van de Vijver et al. 1999). These losses may vary greatly depending on fire temperature, which again depends on amount and type of the biomass and timing of the burning (Fynn et al. 2002). Plant nutrients bound in above-ground organic matter will be rendered available and concentrated at the soil surface through the ash (Boerner 1982; Christensen 1977). Burning may also increase mineralization of nutrients in the topsoil (Hobbs and Schimel, 1984; Hulbert 1988; Singh 1993). Ash may have a liming effect and increase pH in the topsoil, resulting in increased availability of P, Mg, Mo, and possibly reduced availability of some nutrients, depending on pH and nutrient status in the soil. P may be bound as Ca-phosphates if pH increases beyond 7, which was the case for the samples taken from Sirba. Removal of all

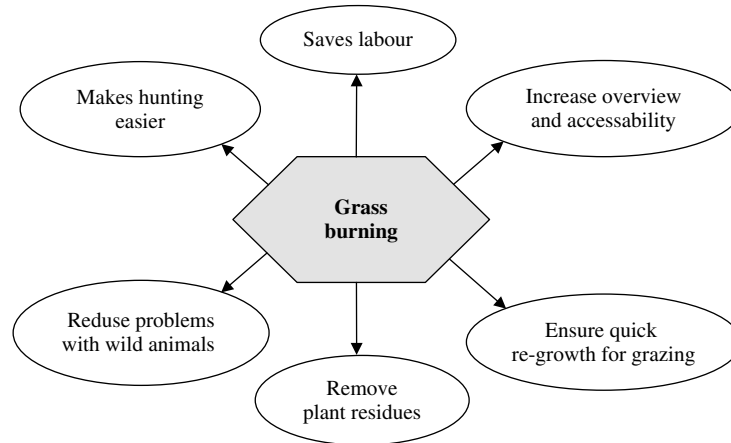

Figure 3a. Importance of grass burning from a local farmers perspective.

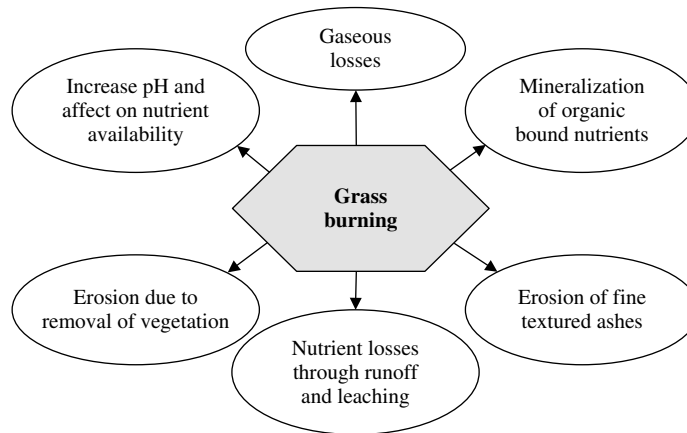

Figure 3b. Implications of grass burning from a soil fertility perspective.

vegetation by burning will increase the risk of soil erosion (Jansson 1982). Soil erosion is a selective process, removing the finer particles before the coarser fractions (Gachene et al. 1997; Våje 1998), which makes the fine-textured, and high nutrient content–nature of ash very prone to wind and water erosion as well as loss through runoff and leaching.

Changes in current agricultural practice

The slash- and burn-agriculture has been sustainable up to now, given the very scattered population and abundance of land. This situation, however, is rapidly changing due to the population growth of humans and cattle as well as more permanent settlements leading to increasing pressure on land. The balanced exploitation

of the resources in a shifting cultivation system has been transformed to an unsustainable exploitation of the resources, as described by several authors (Ruthenberg, 1980, IITA, 1993, Dixon et al. 2001; Nandwa, 2003). The negative effects on agriculture and the environment are evident. Reduced fallow periods leading to a decline in soil fertility (van Reuler and Prins, 1993). More areas under continuous cropping without any external fertilizer input leading to soil fertility mining (Stoorvogel and Smaling, 1990). Striga becoming a dominant weed, and declining crop yield due to continuous cropping and poor soil fertility management. A decline in labour availability for agriculture and animal husbandry due to paid jobs by the government and children going to school leads to a suboptimal timing of agricultural practices such as weeding and more damage in fields by birds and animals.

Under the current agricultural practice, yields per ha are declining due to the above mentioned reasons. This combined with the increased need for food due to population growth leads to more clearing of land and more land under continuous cultivation. The vicious circle of land degradation and lack of resources and knowledge described by Bationo (2004) has started. The increased need for firewood and building materials is furthermore putting pressure on the forest reserves.

Conclusion

The study has provided evidence of a rapidly progressing soil fertility decline in the area. Soil samples have indicated a loss in soil fertility with continuous cropping and reduced SOC after clearing and burning of fallow land. Farmers have also expressed concern about decreasing yields and lack of labour and resources. The situation calls for an integrated nutrient management approach where the available resources are utilised in the best possible way to sustain yield and food production. The application of mineral fertilizers, manure, compost, ploughing, early varieties of maize, intercropping with legumes, agroforestry and crop diversification should be a part of this strategy. The project has shown positive effects on maize yield provided management strategies are improved. Establishment of group nurseries for vegetable and fruit tree production, as well as introduction of oxen ploughing have been very well adopted among the local people. Different plant residue-management systems as alternative to burning could also be of great importance. Main criteria for successful adaptation are a low labour demand, immediate positive effect on yields, availability of construction material needed, a high quality of plant material for food and fodder, and a thorough follow-up of qualified extension workers.

Acknowledgement

Agallo Meti Sirba Community Development Project (ASCDP) was funded 90% from NORAD through the Norwegian Missionary Society (NMS). NMS funded the remaining 10 %, and served as the employer for the expatriates. These funds and support from NMS in many ways are highly acknowledged. Similarly important were the practical arrangements of the host NGO and long term partner of NMS, the Ethiopian Evangelical Church Mekane Yesus (EECMY). Without this

cooperation, the project would never be realized. Particular thanks are due to Mrs. Elin Boe, who served as the first agricultural expatriate in ASCDP from 1996 to 2001, and who collected much of the information presented in this paper. The contribution, cooperation and friendship of Lamessa Endalu, project DA and project leader of ASCDP from 2001 to 2004 is also highly appreciated. I would also like to express my gratitude to Jordforsk and to AfNet who made it possible to work on these data in Norway, and to present it at the AfNet conference in Yaounde, Cameroon. I am also grateful to our Gumuz friends who allowed us to live in Agallo Meti and to be a part of the Gumuz way of life. The experience we gained from this certainly enriched our lives. Last, but by no means least, I want to thank my wife, Lilliann, who was my closest co-worker in the project and continues to be my closest friend.

References

- Bationo A., Buerkert A., Sedogo M.P., Christianson B.C. and Mokwunye A.U. 1995. A critical review of crop residue use as soil amendment in the West African Semi-Arid Tropics. In: Powell, J.M., Fernandez-Rivera, S., Williams, T.O. and Renard, C. (eds), *Livestock and Sustainable Nutrient Cycling in Mixed Farming Systems of Sub-Saharan Africa*, pp. 305–322. Volume 2: Technical Papers. Proceedings of an International Conference, 22-26 November 1993. International Livestock Centre for Africa (ILCA), Addis Ababa, Ethiopia.
- Bationo A. (ed) 2004. *Managing nutrient cycles to sustain soil fertility in Sub-Saharan Africa*. Academy Science Publishers (ASP) and Tropical Soil Biology and Fertility (TSBF) of CIAT, Nairobi, Kenya. 608 pp.
- Bezuayehu T., Gezahegn A., Yigezu A., Paulos D. and Mohammad A.J. 2000. Nature and causes of land degradation in the Oromiya region: A review of literature. In: Mohammad A.J., Pender J. and Ehui S. (eds.). *Environment and production technology division*. International food policy research institute (IFPRI), Washington DC.
- Boerner R.E.J. 1982. Fire and nutrient cycling in temperate ecosystems. *BioScience* 32: 187–191.
- Christensen N.L. 1977. Fire and soil-plant nutrient relations in a pine-wiregrass savanna on the coastal plain of North Carolina. *Oecologia* 31: 27–44.
- Cook G.D. 1994. The fate of nutrients during fires in a tropical savanna. *Aust. J. Ecol.* 19: 359–365.
- Dixon J., Gulliver A. and Gibbon D. 2001. *Farming systems and poverty: Improving farmers' livelihoods in a changing world*. FAO and World Bank, Rome, Italy and Washington DC, USA.
- Fynn R.W.S., Haynes R.J. and O'Connor T.G. 2002. Burning causes long-term changes in soil organic matter content of a South African grassland. *Soil Biology & Biochemistry* 35: 677–687.
- Gachene C.K.K., Jarvis N.J., Linner H. and Mbuvi J.P. 1997. Soil erosion effects on soil properties in a highland area of central Kenya. *Soil Sci. Soc. Am. J.* 61: 559–564.

- Hobbs N.T. and Schimel D.S. 1984. Fire effects on nitrogen mineralization and fixation in mountain shrub and grassland communities. *J. Range Manage.* 37: 402–405.
- Hulbert L.C. 1988. Causes of fire effects in tall grass prairie. *Ecology* 69: 46–58.
- IITA (International Institute of Tropical Agriculture), 1993. Sustainable food production in Sub-Saharan Africa 2. Constraints and opportunities, IITA, Ibadan, Nigeria.
- Jansson M.B. 1982. Land erosion by water in different climates. UNGI Rapport Nr. 57. Uppsala Univ. Dept. of Phys. Geogr., Uppsala, Sweden.
- Kapkiyai J.J., Woormer P.L., Qureshi J., Smithson P. and Karanja K.N., 1997. Effects of fertilizer and organic inputs on soil organic matter and nutrient dynamics in a Kanyan Nitisol. In: Bergstrø L. and Kirchmann H. (eds.) Carbon and nitrogen dynamics in natural and agricultural tropical ecosystems. Cab International, Wallingford, UK.
- Kull C.A. 2000. Isle of fire: the political ecology of grassland and woodland burning in highland Madagascar. PhD Dissertation, Univ. California, Berkeley.
- Kull C.A. 2002. Madagascar aflame: landscape burning as a peasant protest, resistance, or a resource management tool? *Polit. Geogr.* 21: 927–953.
- Mekonnen A.G. 2003. Soil fertility decline and integrated nutrient management in Tullo district, Eastern Ethiopia. Noragric MSc thesis. Agric. Univ. of Norway. Ås, Norway.
- Nandwa S.M. 2003. Perspectives on Soil Fertility in Africa. In: Gichuru M.P., Bationo A., Bekunda M.A., Goma H.C., Mafongonya P.L., Mugendi D.N., Murwira H.M., Nandwa S.M., Nyathi P., and Swift M.J. (eds) Soil fertility management in Africa: A regional perspective. Academy Science Publishers (ASP) and Trop. Soil Biol. and Fert. (TSBF) of CIAT, Nairobi, Kenya.
- Olana G.W. 2003. Prospects of integrated soil fertility management in Tullo district, Eastern Oromia, Ethiopia. Socio-economic and institutional challenges and opportunities. Noragric MSc thesis. Agric. Univ. of Norway. Ås, Norway.
- Pivello V.R. and Coutinho L.M. 1992. Transfer of macro-nutrients to the atmosphere during experimental burnings in an open cerrado (Brazilian savanna). *J. Trop. Ecol.* 8: 487–497.
- Pyne S.J. 1995. *World fire*. New York: Henry Holt
- Pyne S.J. 1997. *Vestal fire*. Seattle: University of Washington Press.
- Ruthenberg H. 1980. *Farming systems in the Tropics* 3rd edition. Clarendon press, Oxford, GB.
- Singh R.S. 1993. Effect of winter fire on primary productivity and nutrient concentration of a dry tropical savanna. *Vegetation* 106: 63–71.
- Stoorvogel J.J. and Smaling E.M.A. 1990. Assessment of soil nutrient depletion in Sub-Saharan Africa: 1983-2000. Volume 1. Main report. The Winand Staring Centre, Wageningen, NL.
- Van de Vijver C.A.D.M., Poot P. and Prins H.H.T. 1999. Causes of increased nutrient concentrations in post-fire regrowth in an East African savanna. *Plant and Soil* 214: 173–185.
- Van Reuler H. and Prins W.H. (eds) 1993. The role of plant nutrients for sustainable food crop production in Sub-Saharan Africa. The Dutch Association of Fertilizer Producers (VKP), Wageningen, NL.
- Våje P.I. 1998. Erosional effects on nitrogen uptake and losses in a volcanic ash soil in Kilimanjaro region, Tanzania. Dr. Scient. Thesis 1998:1. Dep. of Soil and Water Sciences, Agric. Univ. of Norway, Ås, Norway.
- World Bank. 1996. Natural resource degradation in Sub Saharan Africa. Restoration of soil fertility. A concept paper and action plan. World Bank, Washington DC.

Overcoming phosphorus deficiency in soils of Eastern Africa: recent advances and challenges

Generose Nziguheba

Laboratory of Soil and Water Management, K.U. Leuven, Kasteelpark Arenberg 20, B 3001 Heverlee, Belgium,
Fax: +32 16 32 1997, E-mail: generose.nziguheba@agr.kuleuven.ac.be

Abstract

Phosphorus deficiency occurs in many soils of East Africa due not only to P depletion through crop harvest and erosion but mainly to the prevalence of high P-fixing soils in the region. Unlike nitrogen, P replenishment, particularly in smallholder agriculture, remains a challenge as it is mainly fertilizer dependent. While soluble mineral P fertilizers are the obvious best means to combat P deficiency, their use is limited by their high cost at farmer's level. Several researches have focused on developing strategies adapted to smallholder farming system for replenishing P and improving its availability to crops. This paper summarizes results from recent studies aiming at combating P infertility in the East African region. Much attention has been given to locally available resources, mainly phosphate rocks and organic materials. Most of the phosphate rock deposits available in East Africa are of low reactivity, thus inappropriate for direct application. Their combination with organic resources to improve their solubility has generated controversial results. Partial acidulation of these rocks, though promising, has remained experimental. Minjingu phosphate rock is identified as the largest most reactive deposit in East Africa qualifying for direct application in many acid P-deficient soils. However, a market adapted to smallholder needs to be developed before its adoption. The use of organic materials as P source is handicapped by their low P content and their limited availability. Studies on the contribution of organic resource for improving P availability to crop, either in sole application or in combination with mineral fertilizers indicate the ability of residues from some plant species to increase P availability through the release of their P content, reduction of P adsorption, microbial processes and other non elucidated processes. Other residues have no or negative effect in the short-term. Overall, the quality of the organic resource determines its effect on P availability. However, it has been difficult to establish selection criteria probably because of the many soil processes affected by application of organic resources. One of the major handicaps for understanding processes associated with P availability in soils of East Africa, is the lack or inaccessibility of analytical methods adapted to P-fixing soils.

Introduction

Nutrient depletion in East Africa ranges from high to very high with alarming figures in countries such as Kenya, Ethiopia and Rwanda where annual depletion rates exceeded 40 kg N ha⁻¹, 6.6 kg P ha⁻¹ and 33.2 kg K ha⁻¹ (Smaling et al., 1997). Land scarcity, intensive cultivation without adequate nutrient inputs and water erosion are the main causes of such depletion. Located in the sub-humid zone, the highlands

of East Africa constitute the most potential zones for agricultural production both for the climate and the soils. However, beside the high nutrient depletion, the highlands are dominated by acid P-fixing soils in the orders of Ferralsols, Acrisols, and Nitisols (Deckers, 1993; Sanchez et al., 1997), and phosphorus becomes a major limiting nutrient for crop production in many soils. While the use of soluble fertilizers is the obvious means to overcome P limitation, their application in small scale farming systems is limited by their high

cost as a result of poor infrastructure. The majority of the population in the region is rural and relies on subsistence agriculture. Developing low cost technologies for solving P limitation to crop production has been the core of several researches in the region. The contribution of locally available resources for correcting P deficiency has been given much attention. These include phosphate rocks and organic resources. The East African region has several phosphate rock (PR) deposits but unlike phosphate deposits of West Africa which are mainly of sedimentary origin, most of the East African phosphate rock deposits are of igneous origin and thus not suitable for direct application as P sources (Buresh et al., 1997; Van Straaten, 2002). Numerous strategies for increasing PR solubility have been tested. They include partial acidulation of PRs, their concomitant application with soluble P fertilizers and their combination with organic resources. It is clear that organic resources are insufficient to replenish soil P due to their low P content and availability. Strategies for use of organic resources repose on their role in enhancing the availability of P already in the system rather than replenishing P. This paper reviews results of the different approaches used in the last 10 years with the aim of correcting phosphorus limitation to crop production. Much emphasis is given to P-fixing soils in the highlands of East Africa because the highlands constitute the most potential zone for agricultural production. Limitations to developed approaches, gaps and opportunities are discussed.

Availability of soil P to plants

Plants assimilate P in inorganic form directly from the soil solution. In the absence of fertilization, solution P is replenished from other soil P pools with different degree of availability. The quantity of P reserve to replenish solution P and the ability of a soil to maintain sufficient solution P concentration are the main factors governing P supply to plants (Buresh et al., 1997). Buresh et al. (1997) and Mokwunye and Bationo (2002) partitioned soil suppliers of plant P into Capital P and Agricultural or Liquid P. Capital P is defined as the stock of soil P that gradually supplies plant-available P and includes sorbed P, a portion of primary P minerals and P associated with non labile organic matter. Agricultural or Liquid P represents soil P available to crop within one growing season and includes P in soil solution and labile P. Data reported from numerous experiments in P-deficient soils in the highlands in East

Africa, indicate that the inorganic form of Agricultural P assessed by the Olsen method is less than 5 mg P kg^{-1} soil (Nziguheba et al., 1998; Gachengo et al., 1999; Ikerra, 2004). Capital P represents the largest portion of soil P in these soils. Reported data from the NaOH extractable P in sequential extraction, which presumably represents a large portion of Capital P in highly weathered P-fixing soils, ranges from 300–400 mg P kg^{-1} soil (Nziguheba et al., 1998; Maroko et al., 1999; Ikerra, 2004). It follows that P deficiency to crops results mainly from limited supply of Agricultural P. Short-term management options should prioritize the increase of Agricultural P whereas building capital P should be regarded as a long-term investment for sustainability.

Phosphorus rocks for P replenishment

The East African region has several PR deposits which are considered as the main potential resources for phosphorus replenishment (Buresh et al., 1997; Van Straaten, 2002). Two types of deposits are distinguished: sedimentary/biogenic and igneous/residual deposits. The few sedimentary/biogenic deposits are located in the East African Rift Valley, with the most and largest known deposit at Minjingu in Northern Tanzania (Van Straaten, 2002). Igneous/residual PRs are widespread in the region (Buresh et al., 1997; Van Straaten, 2002). Phosphorus deficient soils in the highlands are generally acidic, thus providing suitable soil conditions for the use of PRs. However, due to their low reactivity, most of these phosphate rocks qualify for replenishing Capital P but they are seldom sufficient as source of Agricultural P. Approaches studied to improve their solubility and effectiveness are viewed in the following sections.

Partial acidulation or Compaction with soluble fertilizers

Partial acidulation of PRs is the most known practice to increase P solubility while reducing the cost of commercial fertilizers. Raw or concentrate phosphate rock is treated with a portion of the phosphoric acid and/ or sulphuric acid required for soluble P fertilizers (single or triple superphosphate) production. In this way, the cost is reduced compared to that of soluble fertilizers. Results from various experiments

Table 1. Reported effectiveness of selected East African phosphate rocks applied either directly or after partial acidulation.

	Rate kg P ha ⁻¹	Level of acidulation	RAE (%)	Soil	Crop	Duration	Source
Minjingu	0–80	0	114	Vertisol (Ethiopia)	Clover	5 years	Haque et al., 1999
		25	113				
		50	107				
Chilembwe	0–80	0	27	Vertisol (Ethiopia)	Clover	5 years	Haque et al., 1999
		25	46				
		50	73				
Matongo	0–100	0	8	Ferralsol (Burundi)	Bean	1 year	Nziguheba, 1993
		50	83				
Sukulu	0–600	0	1	Ultisol (Uganda)	Maize	6 weeks	Butegwa et al., 1996
		50	54.8				
						Green house	

with partial acidulated PRs showed improved relative agronomic effectiveness (RAE) of low reactive phosphate rocks such as Matongo phosphate rocks (Burundi) (Nziguheba, 1993) and Chilembwe phosphate rock (Malawi) (Haque et al., 1999) (Table 1). Butegwa et al. (1996) reported an increase in RAE after partial acidulation of concentrate Sukulu PR but no improvement from the partial acidulation of raw PR and concluded that partial acidulation can be inhibited by high Fe₂O₃ in PRs. Relative effectiveness of partially acidulated rocks increased with high rates of acidulation and with the application rates (Nziguheba, 1993; Haque et al., 1999). However, partial acidulation of high reactive Minjingu phosphate rock, tended to reduce its effectiveness (Haque et al., 1999) (Table 1).

Combined application of phosphate rocks with soluble P fertilizers with or without prior compaction was also tested and resulted in improved effectiveness of both low reactive PRs (Mpanda hills, Sukulu, Matongo) (Nziguheba, 1993; Butegwa et al., 1996) and the high reactive Minjingu PR (Mowo, 2000). In two studies where both partial acidulation and compaction were tested, compaction tended to be more effective than the partial acidulation of the same rocks with reported RAE of partial acidulation vs. compaction of 75% vs. 83% in Nziguheba (1993), and 54.8% vs. 94.4% in Butegwa et al. (1996). Although either partial acidulation or compaction with soluble P fertilizers proved to be effective in increasing crop yield, these practices have remained experimental and little information is available on their economic value. An investment in acidulation or compaction practices is required before any adoption is envisaged. Combined application of phosphate rocks and soluble P fertilizers without prior compaction may be more feasible but would require high labor for the double application, thus

the need for economic assessment of the profitability of such practice.

Organic resources and phosphate rock solubility

Combined application of PRs and organic resources

It is expected that decomposing organic materials release protons that would provide adequate conditions for PR dissolution. Based on this, studies on combined application of PRs with organic resources have received some attention. However such studies have generated controversial results and reasons for divergence are still not well understood. Earlier research in East Africa focused on the combination of the most commonly used organic materials, i.e. farmyard manure and compost, with phosphate rocks and reported positive effect on PR solubility (Ikerra et al., 1994). Composting with Matongo PR (Van den Berghe et al., 1996) or Tundulu PR (Nyirongo et al., 1999) did not improve crop yield compared to the compost produced without PR addition. Likewise, no increase in Minjingu PR dissolution was observed by combining it with farmyard manure in Tanzania (Mowo, 2000). However, Waigwa et al. (2003) reported improved RAE of Minjingu PR on maize yield when combined with farmyard manure in western Kenya but the magnitude of increase varied with sites.

The concept of high quality organic materials which emerged mainly in Agroforestry systems stimulated the combination of these materials with phosphate rocks to increase their solubility. Active research was conducted in this line with little progress. The combination of Minjingu phosphate rock with leaf biomass from *Tithonia diversifolia*, *Lantana camara* and *Gliricidia*

Table 2. Influence of organic materials on P release from Minjingu PR assessed by the NaOH extractable P during 112 day incubation. Values (mg kg^{-1}) are net increase of NaOH extractable P from the values in a non treated soil (control).

Treatments	Incubation period in days				
	1	7	14	28	112
MPR	114 a	121 b	149 a	182 a	205 a
MPR + Manure	105 a	109 c	134 b	124 c	159 c
MPR + Lantana	61 c	96 d	127 b	159 b	189 ab
MPR + Gliricidia	87 b	141 a	136 d	151 b	184 b
MPR + Tithonia	82 b	105 cd	110 c	106 d	156 c

Source: Ikerra, 2004.

sepium depressed maize dry matter yield and soil available P compared to the sole application of Minjingu (Savini, 2000; Smithson, 1999; Ikerra, 2004) (Table 2). Zaharah and Bah (1997) concluded from their study that green manures generally increased the solubility of less reactive PRs and depressed that of more reactive ones. Likewise, Kpombekou and Tabatabai (2003), working on a range of PRs and a range of low molecular weight organic acids, found little or no effect of organic acids on solubility of high reactive phosphate rocks, including Minjingu PR whereas they increased the solubility of less reactive PRs. Processes underlying reduced solubility and effectiveness of PRs by organic resources converged towards increased pH and

Ca concentrations which constrain further dissolution of PRs.

Interaction between Legumes and Phosphate rocks

Rhizosphere acidification by legumes could improve the solubility and P availability from phosphate rocks. In East Africa, this approach has been seldom tested. In a greenhouse trial in Tanzania, Mowo (2000) tested the effect of intercropping legumes (cowpea or pigeonpea) with maize on P availability from Minjingu PR. Results indicated better P uptake by legumes than maize, and enhanced P uptake by maize intercropped with legumes compared to maize grown alone. In a pot trial, Weil (2000) reported dramatic increase in P uptake and yield of cabbage grown on soil amended with Panda PR or Minjingu PR, but no effect for maize, bean or pigeon pea. However, maize grown after pigeon resulted in higher yield and P uptake than that grown after cabbage. In western Kenya, the influence of improved fallows of *Crotalaria grahamiana* or *Tephrosia vogelii* on Busumbu PR performance is being tested and preliminary results showed a significant additional fallow effect on maize yield, which was attributed to improved soil P status (Smithson and Kimiti, unpublished) (Figure 1). The identification of crops apt to utilize P from PR and the development of adequate crop sequences can be considered as one strategy to effectively integrating PRs in farming systems.

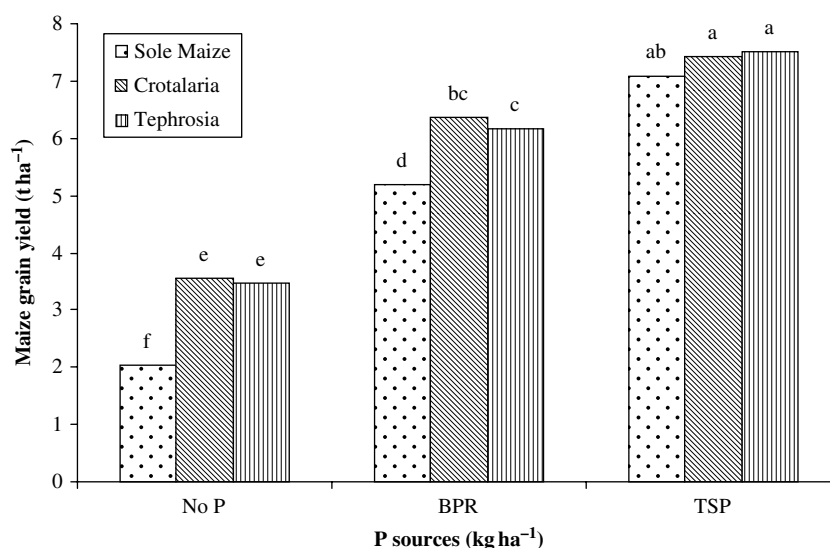

Figure 1. Maize grain yield in improved fallow with additions of Busumbu phosphate rock or triple superphosphate on a P deficient soil in western Kenya.

Source: Smithson and Kimiti, unpublished.

Minjingu Phosphate rock case study

The Minjingu phosphate deposit is located at a small hill in the plains of the eastern side of Lake Manyara, about 110 km SW of Arusha in northern Tanzania (Van Straaten, 2002). Two types of phosphates have been identified at Minjingu, the “soft” and “hard” ore (Van Straaten, 2002). The grade of most of the soft phosphate ore is between 22 and 25% P₂O₅, whereas the hard ore averages about 24% P₂O₅. Details on its composition have been reported by Smithson et al. (2001) and Van Straaten (2002). Minjingu phosphate is the largest most known deposit of sedimentary/biogenic origin in East Africa and is regarded as the most promising P source in the region. Results from most agronomic experiments indicate that the PR is suitable for direct application (Mowo, 2001, Smithson et al., 2001). Minjingu PR was more efficient when broadcast than with band application (Mowo, 2000). Combined application of Minjingu PR with organic resources to increase its solubility and effectiveness has often resulted in depressive effect (Savini, 2000; Kpomblekou and Tabatabai, 2003; Ikerra, 2004). Though not clearly explored, reasons for such depression converge towards an increase in pH and Ca due not only to organic resources but to the presence of Ca as impurity in the PR. The residual effect of Minjingu PR is high and it qualifies for increasing both Capital P and Agricultural P (Mutuo et al., 1999; Smithson et al., 2001).

On economical point of view, initial experiments in western Kenya indicated Minjingu PR as an attractive P source compared to triple superphosphate (TSP) under smallscale farming systems. Buresh et al. (1997) estimated that the retail price of Minjingu PR in western Kenya in December 1996 was about 55 to 76% that of TSP on a P basis. Mutuo et al. (1999) obtained RAE of Minjingu PR on maize in the same area of 107% in the first season and 79% in the third season, both higher than the estimated relative cost (55 to 76%). In a P recapitalization experiment in western Kenya, cumulative maize yield over 5 years did not differ between Minjingu PR and TSP whether P sources were applied once at 250 kg P ha⁻¹ at the beginning of the first season or gradually applied at 50 kg P ha⁻¹ year⁻¹ (Figure 2) (Smithson et al., 2001). This means that Minjingu PR could be an economically attractive P source in western Kenya. However, multi-locational trials, resulted in a high variability in the RAE of Minjingu ranging from 41–113% which would lead to different economical conclusions of the PR, ranging from less attractive to very attractive compared to TSP (Smithson et al., 2001). More economical studies, based on long-term experiments and not on RAE, are needed which take into account labor cost for application of the PR. Despite attractive performance of the Minjingu PR in western Kenya, its market is currently limited. Woomer et al. (2003) elaborated a nutrient replenishment product (PREP-PAC) adapted

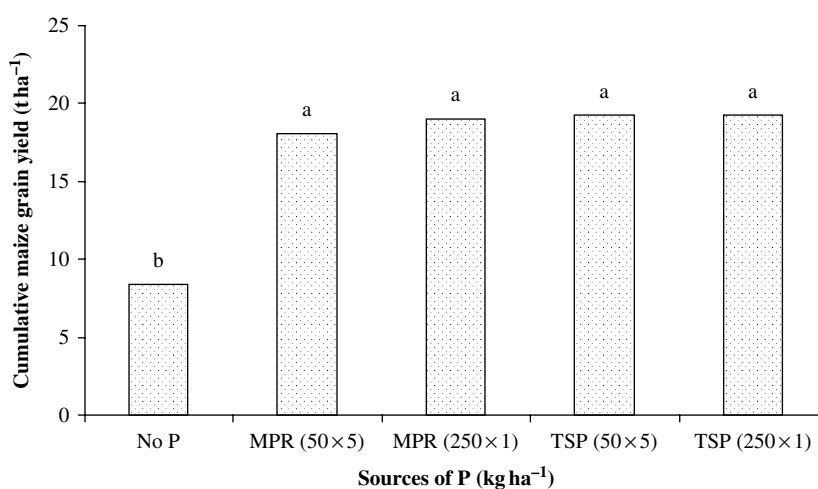

Figure 2. Cumulative maize grain yield after 5 years in a P recapitalization experiment with Minjingu phosphate rock and triple superphosphate in western Kenya. P source are applied either in one time (250 kg P ha⁻¹) at the beginning of the experiment, or gradually (50 kg ha⁻¹ every year).

Source: Smithson et al., 2001.

to small scale farmers containing Minjingu PR as the phosphorus source. The nutrient replenishment product was assessed and found attractive both agronomical and economically in western Kenya.

Organic resources for improving phosphorus availability to crops

Animal manure, compost and crop residues are the most commonly used organic resources in smallholder farming systems in East Africa but are often of low quality. Many plant species in the vicinity of farms may play a role in soil fertility improvement (Nandwa and Bekunda, 1998) but they vary in P content within and between species (Table 3). Organic resources will play limited role in replenishing soil P due to their low P content and their limited supply at farm level (Palm et al., 1997). However, organic materials may increase Agricultural P by improving the availability of phosphorus already in the system through different processes. This is particularly important in P-fixing soils where a major proportion of soil P is unavailable in the short-term due to fixation. The exploitation of the reserve of unavailable P in these soils can be a standby strategy to increase P in soil solution before adoption of more sustainable strategies with mineral fertilizers. This implies the development of management practices for judicious utilization of this stock. The identification of plant species with an ability to take up P from less available soil P and to recycle it

into more available forms is an essential way to reduce P limitation to crops.

Different ways exist for accessing less available P: (i) plants with an extended rooting pattern can access a larger soil volume than plants with smaller roots, (ii) some plants can modify their rhizosphere through root exudates (phosphatases, organic acids) which can dissolve some soil P otherwise not available to crops (Jones and Farrar, 1999), and (iii) the association of roots with mycorrhizae has been reported to increase uptake of P (Godbold, 1999). In western Kenya, processes identified as possible reason for high P content in leaves of *Tithonia diversifolia*, and probably in other high P content plant species, include extended lateral rooting, phosphatase secretions which solubilise organic P, and association with mycorrhizae (George, 2000). Assimilated P is recycled in more available form through decomposition of plant residues added to soil. Available P in many P deficient soils in East Africa is so low that crops respond to P rate as low as 10 kg ha⁻¹ (Jama et al., 1997, Nziguheba et al., 2002). Based on Table 3, large addition of high quality organic materials (about 4 tonnes per hectare) would be needed to increase crop yield. Beside the direct release of their P content, the alteration of soil reactions governing soil P sorption processes through organic residue amendments can also increase phosphorus availability. These include the release of organic anions during the decomposition which in turn may compete with P for adsorption sites (Hue, 1991), increase in soil pH and in soil aggregate size and decrease of exchangeable Al and of specific surface area (Công, 2000). It should be noted however that the use of plant materials for P replenishment contribute to soil P mining and should be considered as temporary strategies aiming at improving P availability before more sustainable strategies are developed.

In order to explore the above-mentioned opportunities with plant materials, numerous studies have been conducted in East Africa mainly in agroforestry systems. The main technologies developed to maximize the benefits of trees and shrubs for nutrient supply and availability to crops are biomass transfer and improved fallows. Biomass transfer technology consists of incorporation into the soil of biomass (mainly leaf biomass) from plant species collected from outside the farms. In situ incorporation of biomass from short-duration (6–18 months) improved fallows using leguminous shrubs combine the benefit of deep nutrient capture and biological N₂ fixation for restoration of soil fertility.

Table 3. Range of nutrient contents in leaves of some organic materials found in East Africa. (based on 4 tonnes dry weight of plant material).

Organic material	N (%)	P (%)	K (%)
<i>Leucaena leucocephala</i>	2.8–6.1	0.12–0.33	1.3–3.4
<i>Calliandra calothyrsus</i>	1.1–4.5	0.04–0.23	0.6–1.9
<i>Crotalaria grahamiana</i>	3.0–3.6	0.13–0.14	0.9–1.6
<i>Lantana camara</i>	2.3–4.0	0.18–0.30	1.8–2.4
<i>Sesbania sesban</i>	1.4–4.8	0.11–0.43	1.1–2.5
<i>Trephrosia vogelii</i>	2.2–3.6	0.11–0.27	0.5–1.3
<i>Tithonia diversifolia</i>	3.1–4.0	0.24–0.56	2.7–4.8
<i>Senna spectabilis</i> [#]	3.2–4.0	0.20–0.26	–
<i>Croton megalocarpus</i> [#]	2.6–2.9	0.17–0.23	–
Maize stover	–	<0.1	–

Source: Palm, 1995; Gachengo et al. unpublished unless indicated

[#]From Nziguheba et al., 2000. Analyses done on plant materials collected in 6 consecutive seasons in Vihiga district in western Kenya.

Biomass transfer and P replenishment

Sole application of plant materials

Most studies on biomass transfer in East Africa have assessed changes in soil P fractions and crop yield (mainly maize) after addition of plant residues to the soil. Incorporation of leaf biomass from *Croton megalocarpus*, *Lantana camara* and *Tithonia diversifolia* on a P-fixing Nitisol in western Kenya increase soil labile P, assessed by anion exchange resin method (Sibbesen, 1978) to level greater than equivalent levels of TSP during the first maize cropping season (Figure 3) (Nziguheba et al., 2000). Maize yield and microbial biomass were as well increased compared to a treatment with no P addition. In another experiment, Nziguheba et al. (1998) reported increase in resin extractable P and reduction in the amount of sorbed P following incorporation of leaf biomass from *Tithonia diversifolia* but not of maize stover. Likewise, Iyamuremye et al. (1996) reported increased available P and reduced P sorption by high quality residues of alfalfa (*Medicago sativa*) but no effect from wheat straw in soils in Rwanda. Laboratory and field studies

revealed increase in soil pH, reduction in exchangeable Al and Fe (Công, 2000; Maertens, 2003; Ikerra, 2004) with application of *Tithonia diversifolia* to P-fixing soil, all of which favour P availability. A study on a P-fixing Acrisol in Tanzania indicated significant increase in low molecular weight organic acids in soil after incorporation of *Lantana camara* and *Tithonia diversifolia* leaf biomass compared to unamended soil (Ikerra, 2004). Due to the improved biological nutrient cycling and soil physical conditions, organic materials are expected to have longer residual effect on crop yield than soluble fertilizer (Table 4).

Though it is clear that the effect of plant material as P sources varies with the quality of residues, attempts to establish selection criteria and thresholds such as for nitrogen were not successful probably due to the high reactivity of released P and to the effect of added materials on many soil processes controlling P availability. Nevertheless, the P content of plant materials, their C content and particularly soluble P appear to be the main indicators of P availability (Iyamuremye et al., 1996; Gachengo et al., 1999; Nziguheba et al., 2000; Kwabiah et al., 2003; Ikerra, 2004) (Figure 4).

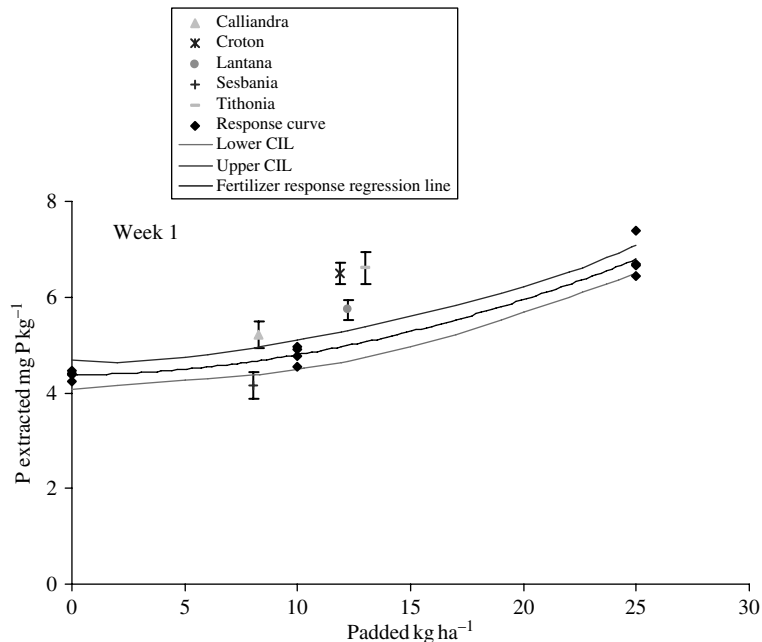

Figure 3. Resin P extracted one week incorporation of organic materials as compared to equivalent P application from triple superphosphate under maize cropping in a P-deficient soil in western Kenya).

Source: Nziguheba et al., 2000.

Table 4. Cumulative maize grain yields during input and residual phase after addition of organic residues to a P-deficient soil in Kenya.

	Input phase (6 seasons) t ha ⁻¹	Residual phase (7 seasons)
120N 0P ^a	5.8	2.9
120N 10P	14.3	6.0
120N 25P	19.5	6.5
<i>Calliandra Calothyrsus</i>	11.7	13.9
<i>Senna spectabilis</i>	13.6	16.9
<i>Croton megalocarpus</i>	15.5	15.0
<i>Lantana camara</i>	14.1	15.9
<i>Sesbania sesban</i>	12.8	15.6
<i>Tithonia diversifolia</i>	17.2	15.3

Source: Nziguheba, unpublished.

^a N and P input from urea and TSP expressed in kg ha⁻¹, organic materials were added at 5 t ha⁻¹. Fertilizers and organic materials are applied at the beginning of every cropping season during the input phase.

Combined application of organic materials and soluble fertilizers

Palm et al. (1997) estimated the amount of P needed to produce 2 tonnes of maize grain to be 18 kg P ha⁻¹. Based on data in Table 3, large amounts of residues would be required to meet the adequate supply even for high quality plant materials. There is limited supply of organic residues in the vicinity of farms. The combination of organic materials and soluble P fertilizers addresses the problem of limited accessibility to both plant materials and commercial fertilizers. Conceptually, the combination of mineral fertilizers and organic materials would be advantageous than the sole application of fertilizers owing to the many other soil biological and physical properties improved by the presence of the organic resources. The quality of the organic material used and the proportions of nutrient applied from either source would determine the effect of the combination (Palm et al., 1997). The combination of plant materials and soluble fertilizers has been assessed both on soil P availability and on maize yield. The combination of TSP and leaf biomass from the high quality *Tithonia diversifolia* at 50:50 P ratio provided similar labile P (anion resin or bicarbonate extractable P) as that extracted from either source (Nziguheba et al., 1998). The combination of low quality residue maize stover with TSP provided intermediary values between those obtained from the application of the two sources separately. In an agronomical test, more maize yield was harvested from the combination of TSP with leaves of *Tithonia diversifolia* than from its

combination with *Senna spectabilis* in western Kenya (Gachengo et al., 1999). Likewise, the combination of TSP with farmyard manure was more effective than that with *Calliandra calothyrsus* on maize (Jama et al., 1997). In an experiment with different combinations of TSP and *Tithonia diversifolia* but at equal final NPK rates, Nziguheba et al. (2002) reported that maize yield increased with increased proportion of *Tithonia* in the combination. An advantage of combined application of organic and inorganic P sources over organic materials alone is that it contributes to P replenishment from the P fertilizer.

Improved fallow and P availability

Improved fallows were initiated to restore soil fertility in area where long duration fallows are no longer possible due to land shortage. They are adapted to cropping systems where one cropping season (mainly short rainy season) is often unreliable for crop production. They were tested successfully in small-scale farming systems in Eastern and Southern Africa. While the contribution of this technology to N replenishment, using N₂-fixing legumes, stands above questioning, data on phosphorus are scarce. Higher P uptake by fallow species is expected compared to maize owing to their extended rooting zone. However the recycling of the P uptake and its availability to following crop are presumably governed by the same plant parameters discussed in the biomass transfer section. The quality of the material returned to soil would determine its contribution to P availability. In improved fallow with *Sesbania sesban* in western Kenya, Jama et al. (1998) and Maroko et al. (1999) reported increase in maize yield grown after incorporation of sesbania leaf biomass compared to continuous maize on site where rainfall was not limiting but not on site with erratic distribution of rainfall. Addition of P fertilizer on maize grown after fallow significantly increased maize yield compared to continuous maize at both sites. Likewise, significantly higher maize yield in *Crotalaria grahamiana* fallow-maize rotation than in continuous maize was observed only when P was applied to maize grown after the fallow (Buneman, 2003). In studies by both Maroko et al. (1999) and Buneman (2003) improved fallow had no effect on available P assessed by bicarbonate or anion exchange resin extraction. However microbial biomass P and NaOH extractable organic P were increased in the fallow systems compared to continuous maize, indicating improved P cycling in these

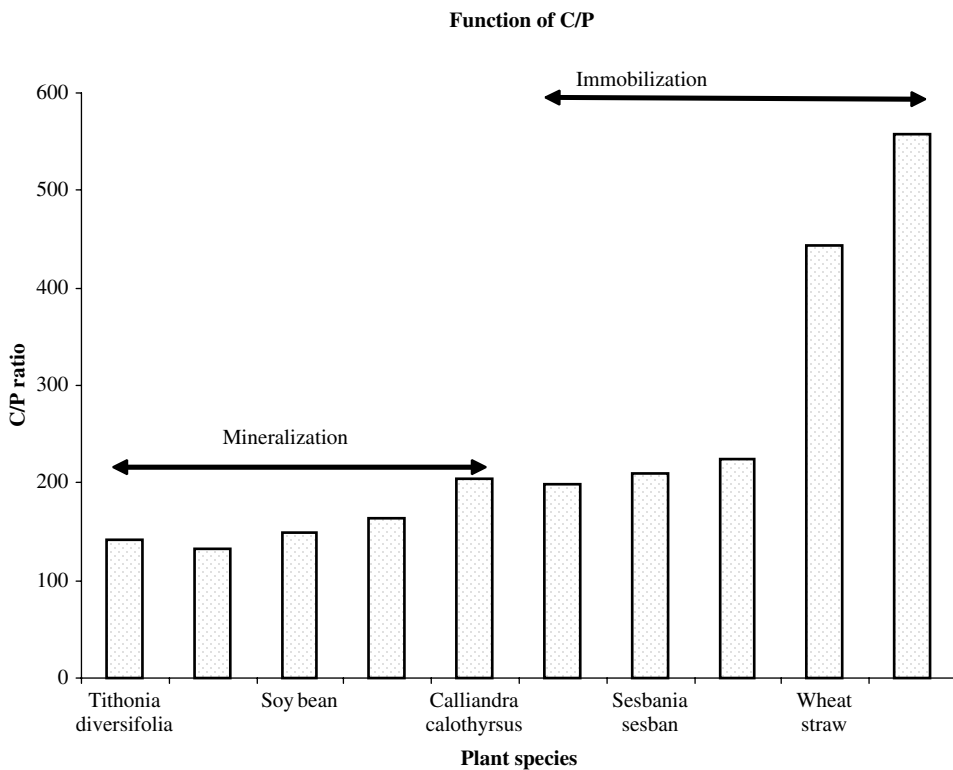
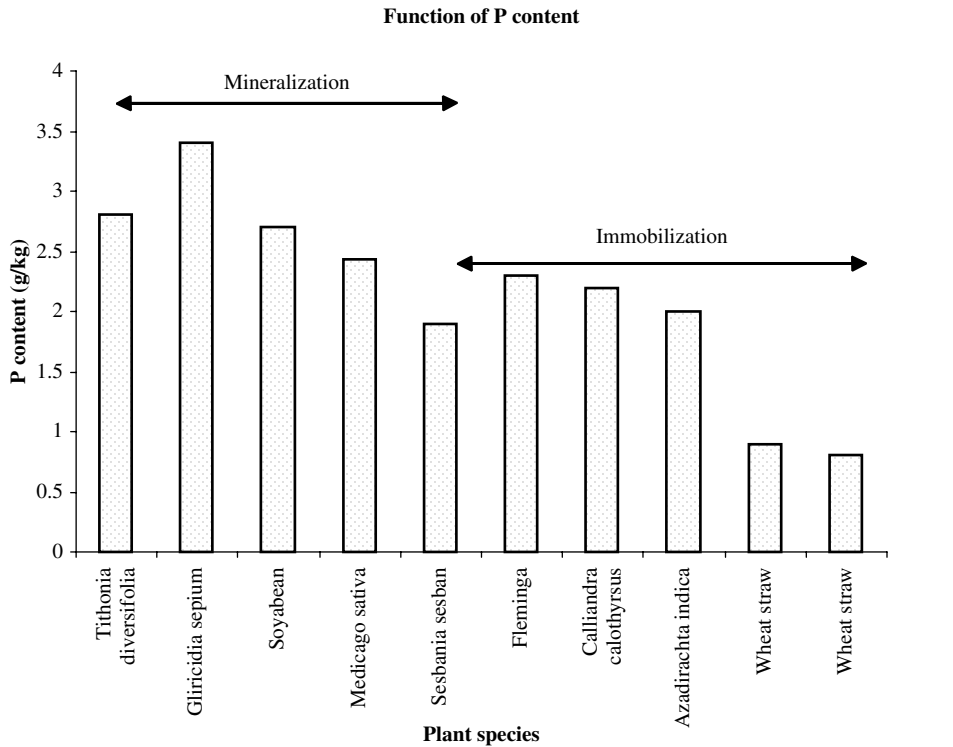

Figure 4. Influence of P and C/P in organic materials on availability of P in selected experiment in East Africa. Source: Iyamuremye et al., 1996; Gachengo et al., 1999; Nziguheba et al., 2000; Kwabiah et al., 2003; Ikerra, 2004.

systems. These organic P pools contributed to available P after mineralization. The P content in leaf biomass produced in these improved fallows was low and could lead to short-term P immobilization after incorporation of the leaf biomass. It can be concluded from the above that improved fallows are unlikely to eliminate P limitation to crops in P-deficient soils, thus a need for P fertilization for the crop grown after the fallow.

Economic evaluation

Only few studies have attempted an economic evaluation of the use of organic resources as source of phosphorus. Jama et al. (1997) evaluated the economic benefit of applying 10 kg P ha⁻¹ from *calliandra calothyrsus* leaf biomass (0.13% P), farmyard manure (0.49% P) or their mixture with soluble fertilizers (TSP, urea) for maize production in two P-deficient soils in western Kenya. Positive net benefit, higher than that of fertilizers was observed from manure, whereas the incorporation of Calliandra alone resulted in negative net benefit in the season following the application. However, combined application of Calliandra and TSP (50:50 P) resulted in net positive benefits. Nziguheba et al. (2002) evaluated net positive benefits for biomass transfer from *Tithonia diversifolia* (0.33% P) either applied alone or in combination with TSP on maize in western Kenya. It was concluded from both studies that organic materials suitable for use as P source should have a high P content and low cost of production. Collecting organic materials from existing niches on farm boundaries would be more attractive but the strategy is constrained by limited supply of materials. A more attractive use of *Tithonia diversifolia* and probably other high P quality organic materials in western Kenya, was its application to high value crops such as vegetables (Jama et al., 2000).

Economic evaluation of a 1.5 year old Sesbania sesban improved fallow in western Kenya, indicated positive net benefit for maize production only when maize was not limited by rainfall (Jama et al., 1998). However, this fallow technology was more attractive when P was added to maize after fallow.

Assessment of Capital and Agricultural P in developed approaches: a challenge

For better interpretation of agronomic data and for sustainability, soil processes involved in approaches developed to improve soil fertility need to be understood.

Several methods have been developed for characterizing plant available P (Agricultural P). In many cases, increases in crop yield were observed under agroforestry systems with little or no effect on soil P availability tests (Maroko et al., 1999; Nziguheba et al., 2000; Buneman, 2003). Currently available tests were developed for use with water-soluble P fertilizers and in high input systems and may not qualify for water-insoluble P sources (PRs) or for low-input organic-based systems. In addition, most of these methods use chemical extractants that may not be adapted to developed approaches. In their study on Minjingu PR, Mutuo et al. (1999) reported that acid extractant (1M HCl) tended to overestimate the bioavailability of P from the PR while alkaline extractant (0.1M NaOH) underestimate it. The anion exchange resin method (Sibbensen, 1978) is believed not to alter chemical properties of the soil and has been used successfully to detect changes in many systems including those with phosphate rocks (Mutuo et al., 1999) and organic resources (Nziguheba et al., 1998). Often resin P data do not correlate with crop yield, indicating limitation of the method to predict yield. The anion resin can extract significant amount of sulphur (Nziguheba et al., 2005). In agroforestry systems, significant amounts of sulphur can be added along with P, and P extraction with the method may be constrained by sulphur.

Organic-based systems improved P cycling as indicated by phosphatase, microbial biomass P and soil organic P. Mineralization of organic P may play an important role for plant nutrients in these systems but also in systems with no P fertilization. One way to understand the contribution of the organic pools to plant nutrients is to study the dynamics of these pools. The sequential method (Hedley et al., 1982; Tiessen and Moir, 1993) which extracts P of differing degrees of availability is used all over the world to evaluate the distribution of P in soil inorganic and organic P pools. While this method can be used to evaluate changes in organic P pools as affected by land uses and mineralization, results from agroforestry systems have been complex. The applicability of the method to highly weathered and P-fixing soils is limited because of the acid-precipitation step required to separate organic and inorganic P in the NaHCO₃ and NaOH extractions. Inorganic P associated with Fe or Al hydroxides may precipitate together with organic matter upon acidification, resulting in an underestimation of inorganic P and thus an overestimation of organic P (Tiessen and Moir, 1993). Beside this difficulty, the method is time consuming and inadequate for routine work.

Use of isotope methods to assess the availability of P to plants and organic P mineralization in weathered P-fixing soils has been limited by the low solution P, often below detection limit and the high reactivity of P (Frossard et al., 1996). Overall, there is a need to develop sensitive methods, less time consuming, adapted to high weathered soils and to the new approaches for improving P availability.

Conclusions

Despite the recognition of the magnitude of P infertility in East Africa, strategies for its correction remain either at experimental stage or difficult to implement. Most phosphate rocks are not suitable for direct application and some strategies for improving their solubility have been developed. Partial acidulation, though proved to be effective, has not been adopted. Combination of the low reactive phosphate rocks with organic resources has generated controversial results and reasons are not well understood. Studies on combined application of PRs and soluble P sources with or without prior compaction reported improved effectiveness of the PRs. However, compaction remains at experimental stage and tool for compaction need to be developed before commercialization. Combined application of non compacted PRs and soluble P fertilizer, is likely to be adopted by farmers once the market for PRs is developed. However, the double application of the two P sources definitely increases the labor cost and economic evaluations of the strategy are needed.

The high reactive Minjingu phosphate rock was proved to be suitable for direct application in most studies and attempts to increase its solubility often did not improve its effectiveness. Minjingu PR was economically attractive based on relative agronomic effectiveness compared to TSP. However, economic studies based on long-term experiments and which include labor for application are still lacking. Despite promising data with Minjingu PR, a market adapted to smallholder needs to be developed before its adoption.

Organic-based systems, biomass transfer and improved fallow, though not suitable to replenish P, enhance P availability and soil biological activity. These systems can play an important role as standby strategies before adoption of mineral fertilizer in soils with large unavailable P reserves such as P-fixing soils. Combination of organic resources with soluble P fertilizers would be a more suitable strategy for replenishing

both P and N. However there are yet no clear guidelines for selection of organic resources with ability to improve P availability.

Processes underlying the dynamics of soil P in organic-based or phosphate rock-based systems are not well understood due most probably to the lack of sensitivity of most existing extraction methods. There is a need to develop more useful method, adapted to such systems and less time consuming for routine analyses.

References

- Bünemann E.K. 2003. Phosphorus dynamics in a Ferralsol under maize-fallow rotations: the role of the soil microbial biomass. Ph.D. dissertation, Swiss Federal Institute of Technology, Zurich, Switzerland. p. 154.
- Buresh R.J., Smithson P.C. and Hellums D.T. 1997. Building soil phosphorus capital in Africa. In: Buresh, R.J., Sanchez, P.A., and Calhoun, F. (eds.), Replenishing soil fertility in Africa. SSSA/ASA, Madison, WI, pp. 111–149.
- Butegwa C.N., Mullins G.L. and Chien S.H. 1996. Agronomic evaluation of fertilizer products derived from Sukulu Hills phosphate rock. *Fert. Res.* 44: 113–122.
- Công P.T. 2000. Improving phosphorus availability in selected soils from the uplands of south Vietnam by residue management. A case study: *Tithonia diversifolia*. PhD N° 439. K.U. Leuven, Belgium.
- Deckers J. 1993. Soil fertility and environmental problems in different ecological zones of the developing countries in Sub-Saharan Africa. In: Van Reuler H. and Prins W.H. (eds.), The role of plant nutrients for sustainable food crop production in Sub-Saharan Africa. Dutch Association of Fertilizer producers. Leidschendam The Netherlands, pp. 37–52.
- Frossard E., Lopez-Hernandez D. and Brossard M. 1996. Can isotopic exchange kinetics give valuable information on the rate of mineralization of organic phosphorus in soils? *Soil Biol. Biochem.* 28: 857–864.
- Gachengo C.N., Palm C.A., Jama B. and Othieno C. 1999. Combined use of trees, shrubs, and inorganic fertilizers for soil fertility improvement. *Agrofor. Syst.* 44: 21–36.
- George T.S. 2000. Enhanced phosphorus acquisition by *Tithonia diversifolia* and other potential agroforestry species. PhD Thesis. University of Reading, UK.
- Godbold D.L. 1999. The role of mycorrhizae in phosphorus acquisition. Special issue on phosphorus availability, uptake and cycling in tropical agroforestry. *Agrofor. For.* 9: 25–27.
- Haque I., Lupwaya N.Z. and Ssali H. 1999. Agronomic evaluation of unacidulated and partially acidulated Minjingu and Chilembwe phosphate rocks for clover production in Ethiopia. *Eur. J. Agron.* 10: 37–47.
- Hedley M.J. Stewart J.W.B. and Chauhan B.S. 1982. Changes in inorganic soil phosphorus fractions induced by cultivation practices and by laboratory incubations. *Soil Sci. Soc. Am. J.* 46: 970–976.
- Hue N.V. 1991. Effects of organic acids/anions on P sorption and phytoavailability in soils with different mineralogies. *Soil Sci.* 152: 463–471.

- Ikerra T.W.D., Mnkeni P.N.S. and Singh B.R. 1994. Effects of added compost and farmyard manure on P release from Minjingu phosphate rock and its uptake by maize. *Norwegian J. Agr. Sci.* 8: 13–23
- Ikerra S.T. 2004. Use of organic inputs combined with Minjingu phosphate rock in improving phosphorus availability and maize yield on a Chromic Acrisol in Morogoro, Tanzania. Doctorate thesis, Sokoine University.
- Iyamuremye F., Dick R.P. and Baham J. 1996. Organic amendments and phosphorus dynamics: I. Phosphorus chemistry and sorption. *Soil Sci.* 161: 426–435.
- Jama B., Swinkels A.R. and Buresh J.R. 1997. Agronomic and economic evaluation of organic and inorganic sources of phosphorus in Western Kenya. *Agron. J.* 89: 597–604.
- Jama B., Buresh R.J. and Place F.M. 1998. Sesbania fallows on phosphorus-deficient sites: Maize yield and financial benefit. *Agron. J.* 90: 717–726
- Jama B., Palm C.A., Buresh R.J., Niang A., Gachengo G., Nziguheba G. and Amadalo B. 2000. *Tithonia diversifolia* green manure for improvement of soil fertility: A review from western Kenya. *Agrofor. Syst.* 49: 201–221.
- Jones D. and Farrar J. 1999. Phosphorus mobilization by root exudates in the rhizosphere: fact or fiction. *Agrofor. For.* 9: 20–25.
- Kpomblekou K. and Tabatabai M.A. 2003. Effect of low-molecular weight organic acids on phosphorus release and phytoavailability of phosphorus in phosphate rocks added to soils. *Agr. Ecosyst. Environ.* 100: 275–284.
- Kwabiah A.B., Palm C.A., Stoskopf N.C. and Voroney R.P. 2003. Response of soil microbial biomass dynamics to quality of plant materials with emphasis on P availability. *Soil Biol. Biochem.* 35: 207–216.
- Maertens E. 2003. Phosphorus availability in strongly weathered soils: new approaches. PhD Thesis No. 568, KU Leuven, Belgium.
- Maroko J.B., Buresh R.J. and Smithson P.C. 1999. Soil phosphorus fractions in unfertilized fallow-maize systems on two tropical soils. *Soil Sci. Soc. Am. J.* 63: 320–326.
- Mowo J.G. 2000. Effectiveness of phosphate rock on ferralsols in Tanzania and the influence of within field variability. PhD Thesis submitted to Wageningen University, The Netherlands. pp. 164.
- Mokwunye A.U. and Bationo A. 2002. Meeting the phosphorus needs of soils and crops of West Africa: the role of indigenous phosphate rocks. In: Vanlauwe B., Diels J., Sanginga N. and Merckx R. (Eds.) *Integrated plant nutrient management in sub-Saharan Africa: From concept to practice*. CABI, Wallingford, UK, pp. 209–224.
- Mutuo P.K., Smithson P.C., Buresh R.J. and Okalebo R.J. 1999. Comparison of phosphate rock and triple super phosphate on a phosphate deficient Kenyan soil. *Commun. Soil Sci. Plant Anal.* 30: 1091–1103.
- Nandwa S.M. and Bekunda M.A. 1998. Research on nutrient flows and balances in East and Southern Africa: state-of-the-art. *Agric Ecosyst Environ* 71: 5–18.
- Nyirongo J.C.V.B., Mughogho S.K. and Kumwenda J.D.T. 1999. Soil fertility studies with compost and igneous phosphate rock amendments in Malawi. *Afr. Crop Sci J.* 7: 415–422.
- Nziguheba G. 1993. Efficacité agronomique de la roche phosphatée de Matongo (Burundi): Essais sur le haricot. Mémoire. Université du Burundi. Faculté d'Agronomie. pp. 72
- Nziguheba G., Palm C.A., Buresh R.J. and Smithson P.C. 1998. Soil phosphorus fractions and adsorption as affected by organic and inorganic sources. *Plant and Soil* 198: 159–168
- Nziguheba G., Merckx R., Palm C.A. and Rao M. 2000. Organic residues affect phosphorus availability and maize yields in a Nitisol of western Kenya. *Biol. Fertil. Soils* 32: 328–339.
- Nziguheba G., Merckx R., Palm C.A. 2002. Soil phosphorus dynamics and maize response to different rates of phosphorus fertilizer applied to an Acrisol in western Kenya. *Plant Soil* 243: 1–10.
- Nziguheba G., Smolders E, Merckx R. 2005. The immobilization of sulfur in soils measured with the isotope dilution technique. *Soil Biol. Biochem.* 37: 635–644.
- Palm C.A. 1997. Contribution of agroforestry trees to nutrient requirements of intercropped plants. *Agrofor. Syst.* 30: 105–124.
- Palm C.A., Myers R.J.K. and Nandwa S.M. 1995. Combined use of organic and inorganic nutrient sources for soil fertility maintenance and replenishment. In: Buresh R.J., Sanchez P.A. and Calhoun F. (Eds.) *Replenishing soil fertility in Africa*. SSSA/ASA, Madison, WI, pp. 193–217.
- Sanchez P.A., Shepherd K.D., Soule M.J., Place F.M., Buresh R.J., Izac A.M., Mokunywe A.U., Kwesiga F.R., Ndiritu C.G. and Woome P.L. 1997. Soil fertility replenishment in Africa: An investment in natural resource capital. In: Buresh R.J., Sanchez P.A. and Calhoun F. (Eds.) *Replenishing soil fertility in Africa*. SSSA/ASA, Madison, WI, pp. 1–46.
- Savini I. 2000. The effect of organic and inorganic amendments on phosphorus release and availability from two phosphate rocks and triple super phosphate in phosphorus fixing soils. MSc. Thesis, submitted to the Faculty of Agriculture, Department of Soil Science, University of Nairobi, pp. 104.
- Sibbesen E. 1978. Investigation of anion-exchange resin method for soil phosphate extraction. *Plant Soil* 50:305–321.
- Smaling E.M.A., Nandwa S.M. and Janssen B.H. 1997. Soil fertility in Africa is at stake. In: Buresh R.J., Sanchez P.A. and Calhoun F. (Eds.) *Replenishing soil fertility in Africa*. SSSA/ASA, Madison, WI, pp. 47–61.
- Smithson P.C. 1999. Interaction of organic materials with phosphate rocks and triple superphosphate. *Agrofor. For.* 9: 37–40.
- Smithson P.C., Jama B., Delve R., Van Straaten P. and Buresh R. 2001. East Africa phosphate rocks and their agronomic performance. Conference Proceedings: Direct application of phosphate rock and related technology: latest developments and practical experiences. July 16–20, Kuala Lumpur, Malaysia.
- Tiessen H. and Moir J.O. 1993. Characterisation of available P by sequential extraction. In: Carter, M.R. (ed.) *Soil sampling and methods of analysis*. CRC Press, Boca Raton, pp. 75–86.
- Van Straaten P. 2002. Rocks for crops: Agrominerals of sub-Saharan Africa. ICRAF, Nairobi, Kenya, pp. 338.
- Waigwa M.W., Othieno C.O. and Okalebo J.R. 2003. Phosphorus availability as affected by application of phosphate rock combined with organic materials to acid soils in western Kenya. *Exptl. Agr.* 39: 395–407.
- Weil R.R. 2000. Soil land plant influences on crop response to two African phosphate rocks. *Agron. J.* 92: 1167–1175.
- Woome P.L., Okalebo J.R., Maritim H.K., Obura P.A., Mwaura F.M., Nekesa P. and Mukhwana E.J. 2003. PREP-PAC: a nutrient replenishment product designed for smallholders in western Kenya. *Agr. Ecosyst. Environ.* 100: 295–303.
- Zaharah A.R. and Bah A.R. 1997. Effect of green manures on P solubilization and uptake from phosphate rocks. *Nutr. Cycling Agroecosyst.* 48: 247–255.

Relative contribution of trees and crops to soil carbon content in a parkland system in Burkina Faso using variations in natural ^{13}C abundance

J. Bayala^{1,*}, J. Balesdent², C. Marol², F. Zapata³, Z. Teklehaimanot⁴ and S.J. Ouedraogo¹

¹Département Productions Forestières, 03 BP 7047 Ouagadougou 03, Burkina Faso; ²Laboratoire d'Ecologie Microbienne de la Rhizosphère, UMR 6191 CNRS/CEA/Université de la Méditerranée, CEA DEVM Centre de Cadarache 13108, Saint-Paul lez Durance, Cedex, France; ³IAEA, Soil and Water Management and Crop Nutrition Section, Wagramer Strasse 5, P.O. Box 100, A-1400 Vienna, Austria; ⁴School of Agricultural and Forest Sciences, University of Wales, Bangor, Gwynedd, LLL57 2UW, UK; *Author for correspondence (e-mail: jules.bayala@coraf.org or j_bayala@hotmail.com; phone: +226-50-33-40-98 or 50-37-15-80; fax: +226-50-31-50-03 or 50-31-49-38)

Key words: Carbon-13, Crops, Parklands systems, Soil organic carbon, Trees

Abstract

The origin of organic matter was studied in the soils of a parkland of karité (*Vitallaria paradoxa* C.F. Gaertn) and néré (*Parkia biglobosa* (Jacq.) Benth.), which is extensively cultivated without the use of fertilisers. In such systems, fertility (physical, chemical and biological) gradients around trees have been attributed by some authors to a priori differences in fertility, allowing for better tree establishment on richer sites. In reverse, other workers believed that these gradients are due to the contribution of trees to the formation of soil organic matter through litter and decay of roots. Measurements of the variations in the ^{13}C isotopic composition allowed for a distinction between tree (C_3) derived C and crop and grass (C_4) derived C in the total soil organic C content. The organic carbon contents of the soils were recorded under the two species at two soil depths and at five distances going from tree trunk to the open area and their C isotopic signatures were analysed. The results showed that soil carbon contents under karité ($6.43 \pm 0.45 \text{ g kg}^{-1}$) and néré ($5.65 \pm 0.27 \text{ g kg}^{-1}$) were significantly higher ($p < 0.01$) than in the open area ($4.09 \pm 0.26 \text{ g kg}^{-1}$). The $\delta^{13}\text{C}$ of soil C was significantly higher ($p < 0.001$) in the open area ($-17.5 \pm 0.3\text{‰}$) compared with the values obtained on average with depth and distance from tree under karité ($-20.2 \pm 0.4\text{‰}$) and néré ($-20.1 \pm 0.4\text{‰}$). The C_4 -derived soil C was approximately constant, and the differences in total soil C were fully explained by the C_3 (tree) contributions to soil carbon of 4.01 ± 0.71 , 3.02 ± 0.53 , $1.53 \pm 0.10 \text{ g kg}^{-1}$, respectively under karité, néré and in the open area. These results show that trees in parklands have a directly positive contribution to soil carbon content, justifying the need to encourage the maintenance of trees in these systems in semi-arid environments where the carbon content of soil appears to be the first limiting factor for crop growth.

Introduction

The coexistence of woody plants and grasses in subtropical and tropical savanna ecosystems,

called parklands, is currently of great interest due to the rate at which relative tree abundance declines by human influence, especially through manipulation of fire, grazing and bush clearing to

This article has been previously published in the journal "Nutrient Cycling in Agroecosystems" Volume 76 Issues 2–3.

create crop fields. In parkland systems, the woody plant component is comprised exclusively of C_3 species and the crops of C_4 species (including grass weeds). Therefore, $\delta^{13}C$ values of the soil organic matter can be used to document the relative contributions of these two components of parklands to the soil organic carbon (SOC) contents in savanna region (Balesdent and Mariotti 1996; Boutton 1996; Andriulo et al. 1999; Diels et al. 2001).

The soil carbon contents constitute one of the factors essential for assessing the sustainability of cropping systems and their effect on the environment particularly in region with kaolinite as the main type of clay in the soils (Andriulo et al. 1999; Bationo and Buerkert, 2001). For their contribution to soil carbon contents, trees have a different impact on soil properties than annual crops, because of their longer residence time, larger biomass accumulation, and longer-lasting, more extensive root systems. In natural forests nutrients are efficiently cycled with very small inputs and outputs from the system (Sanchez et al. 1997). In most agricultural systems the opposite happens. Agroforestry encompasses the continuum between these extremes, and emerging hard data is showing that successful agroforestry systems increase nutrient inputs, enhance internal flows, decrease nutrient losses and provide environmental benefits, when the competition for growth resources between tree and the crop component is well managed (Sanchez et al. 1997). Therefore, there is a strong need to develop research activities on soil C sequestration as this is truly a win-win situation (Lal 2002). Above- and below-ground carbon sequestration values, however, need to be generated locally, taking into account the duration of each agroforestry system, and extrapolated geographically in a realistic fashion, based on actual rates of agroforestry adoption (Sanchez et al. 1997).

Although fertility gradients around trees have been well studied (Breman and Kessler 1995; Belsky and Amundson 1998), the hypothesis that these differences reflect a priori differences in fertility, allowing for better tree establishment on richer sites, forms an alternative to the explanation based on soil improvement by the trees (Brouwer et al. 1993; Van Noordwijk and Ong 1999).

Our aim was to investigate the contribution to soil carbon accumulation of tree and crop (and

grass) components of agroforestry parklands using the natural ^{13}C tracer technique. We hypothesized that tree component would have a higher contribution to soil organic carbon than crops.

Materials and methods

Study site and tree species studied

The study was carried out in the parklands of the village of Saponé (12°03' N and 1°43' W and at an altitude of 200 m), the characteristics of which have been described in Bayala et al. (2002). Soil density and texture data are shown in Table 1 displaying a slight non-significant higher clay content under karité compared to néré as well as under both tree species compared to their open areas (Bayala, Unpublished data). The mean rainfall of the last 10 years was 728 mm. Annual evapotranspiration (ETP_{Penman}) is 1963 mm whereas annual maximum temperature is 34.9 °C and the minimum is 21.5 °C (Sivakumar and Gnoumou 1987). According to FAO (1988) classification the major soils types are Ferric/Luvisols.

The dominant tree species of agroforestry parkland systems in Saponé are *Vitellaria paradoxa* and *Parkia biglobosa*. *V. paradoxa* (known as karité in French and shea butter tree in English) gives a variety of useful products including kernel, medicine, and fuelwood. Karité is the source of vegetable fat which, in Africa, is second in importance only to palm oil (Hall et al. 1996) and its primary traditional role is derived from this oil present in the kernels. Karité belongs to Sapotaceae family. It can grow upto 15 m height and its leaves are as large as 12–25 cm. This species occurs within a belt ranging from 1°00' N to 34°35' E and 13°53' N, 16°21' W (Hall et al. 1996). *P. biglobosa* (known as néré in French and locust bean in English) is found in savannah zones with a natural range extending from 5° N to 15° N and 16° W to 32° E (Hopkins and White 1984). It is a large tree, up to 20 m high, with a wide-spreading crown. *P. biglobosa* belongs to family Mimosaceae, with small leaflets; 0.8–3.0 × 0.2–0.8 cm (Maydell 1983), but it doesn't fix atmospheric N_2 (Dommergues 1987; Tomlinson et al. 1998). The tree yields a condiment locally called 'soubala' (type of cheese

Table 1. Soil physical properties according to tree species, distance from the trunk and soil depth under karité (*Vitellaria paradoxa*) and néré (*Parkia biglobosa*) in an agroforestry parkland system in Saponé, Burkina Faso.

Species	Zone	Depth (cm)	Density (mg m ⁻³)	pH-water	pH-KCl	Texture (%)		
						Clay < 2 µm	Silt 2–50 µm	Sand 50–2000 µm
Karité	A	0–10	1.60	6.59	6.23	21	8.9	70.1
Karité	A	10–30	1.72	6.61	6.29	22	13.6	64.4
Karité	B	0–10	1.58	7.27	6.64	9.5	18	72.5
Karité	B	10–30	1.70	6.46	6.12	17	18.4	64.6
Karité	C	0–10	1.59	6.74	6.50	9.5	19.5	71
Karité	C	10–30	1.71	6.03	5.46	20.8	17.5	61.7
Karité	D	0–10	1.61	6.39	6.14	8.3	19.7	72
Karité	D	10–30	1.73	5.87	5.23	20.5	17.5	62
Karité	Control	0–10	1.63	6.17	5.55	6.5	17.5	76
Karité	Control	10–30	1.75	5.60	5.02	17.7	15.5	66.8
Néré	A	0–10	1.57	7.18	6.72	9.3	23.6	67.1
Néré	A	10–30	1.68	7.29	6.81	18.5	24.7	56.8
Néré	B	0–10	1.53	6.55	6.43	8.8	27.4	63.8
Néré	B	10–30	1.64	6.46	6.30	19	23.7	57.3
Néré	C	0–10	1.60	6.91	6.29	7.2	22	70.8
Néré	C	10–30	1.71	6.14	5.70	19.2	21.5	59.3
Néré	D	0–10	1.63	6.29	6.08	6.8	24.2	69
Néré	D	10–30	1.74	5.86	5.25	17.2	21.2	61.6
Néré	Control	0–10	1.61	6.33	5.99	6.7	19.8	73.5
Néré	Control	10–30	1.72	5.87	5.11	22.3	19.8	57.9

made from seeds), food (pulp), medicine, and fuelwood (Hall et al. 1997).

The two species are scattered forming an open permanent overstorey of associated annual crops consisting of rotation of millet and sorghum without the application of fertilisers.

Sampling approaches

The samples comprised 5 types of material: soil, tree leaves and roots, crop straws and crop roots. Soil sampling was made under randomly selected eight trees including 4 trees of néré (*P. biglobosa*) and 4 trees of karité (*V. paradoxa*). The area around each of the 8 trees was subdivided into 4 concentric zones:

Zone A – from the base of each tree up to 2 m away from the tree trunk;

Zone B – from 2 m to half of the diameter of the crown (on average 1.1 and 3.1 m width for karité and néré, respectively);

Zone C – from half of the diameter of the crown up to the edge of the crown (on average 3.1 and 5.1 m width for karité and néré, respectively);

Zone D – from the edge of the crown up to 2 m outside of the crown; and

A control plot – an area of 4×4 m situated at least 40 m away from the edge of the crown of the selected sample trees to insure that it is not under the influence of any surrounding tree.

Soil samples under trees were taken at 4 points (corresponding to the 4 compass directions east, west, north and south) in each concentric zone and at 2 points in the control plot. Each point was sampled according to two depths, 0–10 and 10–30 cm. The 4 samples from each concentric zone and the 2 samples from each control plot were bulked and mixed thoroughly per soil depth to make a total of 10 samples per tree and a total of 80 for the 8 trees for the 2 species.

Senescent yellow leaves, which were about to fall, were collected from each of the 8 trees. Trees roots extracted during fine root distribution study (Bayala et al. 2004) were bulked and used in the present study. Crop straws and crop roots were collected at harvest. All these samples were oven dried at 70 °C, ground, sieved at 200 µm and analysed for C and ¹³C in the Laboratoire d'Ecologie Microbienne de la Rhizosphère,

CNRS/CEA/Université de la Méditerranée, France.

Laboratory analyses

The carbon content and $\delta^{13}\text{C}$ values of plant and soil samples were determined by dry combustion in a CHN autoanalyser (ThermoFinnigan flash EA series 1112). This apparatus was coupled to an isotope mass spectrometer (ThermoFinnigan DeltaPlus). The ^{13}C natural abundance was expressed in δ units (Eq. 1) in relation to VPDB reference using international standards AIEA C6 and IAEA CH7:

$$\delta^{13}\text{C} = (\text{R}_{\text{sample}} - \text{R}_{\text{standard}}) / \text{R}_{\text{standard}} \times 10^3 \quad (1)$$

where $\text{R} = ^{13}\text{C}/^{12}\text{C}$.

Each sample was analysed 3 times. The analysis was repeated when the difference between replicates from a single sample was more than 0.3‰.

Calculations and statistical analysis

The total soil C content, C_t , the mixed trees-crops of parklands can be expressed as:

$$C_t = C_C + C_T \quad (2)$$

$$C_t \times \delta^{13}\text{C}_t = C_C \times \delta^{13}\text{C}_C + C_T \times \delta^{13}\text{C}_T \quad (3)$$

Where $\delta^{13}\text{C}_t$ is the $\delta^{13}\text{C}$ of the soil organic matter at sampling time, $\delta^{13}\text{C}_C$ is the $\delta^{13}\text{C}$ value of C_4 plants, i.e. the crops and grasses (average of straws and roots values was $-11.7 \pm 0.1\text{‰}$ over a population of 12 samples of sorghum, millet, and bulk grasses), $\delta^{13}\text{C}_T$ is the $\delta^{13}\text{C}$ values of C_3 plants, i.e. trees (averages of leaves and roots values were $-26.2 \pm 0.4\text{‰}$ and $-27.9 \pm 0.5\text{‰}$ for karité and néré, respectively).

The fractions of soil C derived from trees (C_T) and crops and grasses (C_C) were calculated with a simple mixing model (Balesdent et al. 1988; Nyberg and Hogberg 1995):

$$C_T = C_t * (\delta^{13}\text{C}_t - \delta^{13}\text{C}_C) / (\delta^{13}\text{C}_T - \delta^{13}\text{C}_C) \quad (4)$$

$$C_C = C_t * (\delta^{13}\text{C}_t - \delta^{13}\text{C}_T) / (\delta^{13}\text{C}_C - \delta^{13}\text{C}_T) \quad (5)$$

With the hypothesis that R value is not modified with the maturation of organic matter derived from leaves.

The C contents derived from C_4 and C_3 were calculated for each zone by multiplying the fraction of each component by the content of soil organic matter at sampling time for each zone.

The difference between species, zones, and soil depths in all the above parameters was analysed using ANOVA General Linear Model (GLM). Data were analysed as a multifactorial design with three factors (species, zone and depth) and including all possible two-way interactions between these factors and the three-way interaction. Where significant differences were observed Tukey's comparison test was used to separate all the means.

The karité or néré-derived C was obtained by deducting from the value of C_3 -C in each zone the value of C_3 -C obtained in the control (due to the uncertainty linked to possible old C_3). To establish the balance of karité or néré-derived C at the landscape scale, we have multiplied the concentrations of karité or néré-C by soil bulk density and sampling depth to convert it in kg C m^{-2} . Afterward we added the figures of the 2 depths to obtain the value for each zone. This value was multiplied by the surface areas of the zones and the data of zones integrated to give an amount per tree for each species. This amount was extrapolated to the landscape scale by multiplying the mean value of an average tree by the tree density for each species according to 2 modalities: balance up to the edge of the crown and balance up to 2 m outside tree crown influence.

Results

Crops ($-11.7 \pm 0.1\text{‰}$) $\delta^{13}\text{C}$ mean value was more than 2 times higher than that of any of the 2 tree species. $\delta^{13}\text{C}$ of leaves of karité ($-26.6 \pm 0.4\text{‰}$) was higher than that of néré leaves ($-28.7 \pm 0.5\text{‰}$) by almost 2 units whereas the difference was 1 unit in favor of the roots of karité (-25.9‰) in comparison with the roots of néré (-27.1‰). The mean of leaves and roots carbon contents were 463, 430 and 407 mg g^{-1} for karité, néré and the crop, respectively. Interactions between zone and soil depth appeared in soil carbon and tree contribution to soil carbon (C_T) when analyses with three factors were done, suggesting that differences should be looked into separate soil layers

for these 2 parameters. Only tree contribution to soil carbon showed significant difference ($p < 0.01$) between species (Figures 2 and 3). Soil carbon under karité ($6.43 \pm 0.45 \text{ mg g}^{-1}$) and néré ($5.65 \pm 0.27 \text{ mg g}^{-1}$) was significantly higher ($p < 0.01$) than in the control plot ($4.09 \pm 0.26 \text{ mg g}^{-1}$). The trend was similar for tree contribution to soil carbon with 4.01 ± 0.71 , 3.02 ± 0.53 , $1.53 \pm 0.10 \text{ mg g}^{-1}$, respectively under karité, néré and in the control plot. As a consequence the $\delta^{13}\text{C}$ was significantly higher ($p < 0.001$) in the control plot ($-17.5 \pm 0.3\text{‰}$) compared with the figures obtained under karité ($-20.2 \pm 0.4\text{‰}$) and néré ($-20.1 \pm 0.4\text{‰}$) (Figure 1). Nevertheless, it is necessary to indicate that a certain amount of C_3 -derived-C corresponds to organic matter derived from trees of ancient savannas, i.e. old C. This old C can be expected to be spread homogeneously in all zones and thus would encompass the amount of tree-derived C in the control plot, i.e. 1.5 mg g^{-1} .

Results per species showed a significant decreasing trend in soil carbon going from tree

trunk to the open area both for the layer 0–10 cm ($p < 0.01$) and layer 10–30 cm ($p < 0.05$) under karité (Figure 2). Similarly, C_3 contribution to soil carbon decreased significantly in the same way for the upper and lower layer ($p < 0.01$ and $p < 0.001$, respectively). As a result $\delta^{13}\text{C}$ values decreased from the open area to tree trunk ($p < 0.001$) and from the lower layer to the upper layer ($p < 0.01$). Layer 10–30 cm ($2.67 \pm 0.11 \text{ mg g}^{-1}$) displayed significantly ($p < 0.01$) higher C_4 plants contribution to SOC compared to the upper layer ($1.96 \pm 0.26 \text{ mg g}^{-1}$). No significant difference was found in the contribution of C_4 plants to soil

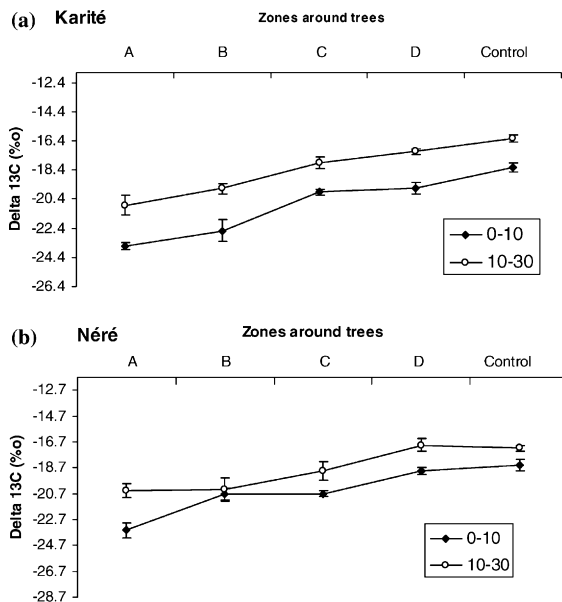

Figure 1. $\delta^{13}\text{C}$ in soil under karité (*Vitellaria paradoxa*) and néré (*Parkia biglobosa*) in a parkland system in Saponé, Burkina Faso; Distance from tree trunk: Zone A = 0 to 2 m from the trunk, Zone B = from 2 m to half diameter of the crown, Zone C = from half diameter to the edge of the crown, Zone D = from the edge of the crown to 2 m outside of the crown, Control = open area; Soil depth: 0–10 = soil depth 0–10 cm, 10–30 = soil depth 10–30 cm.

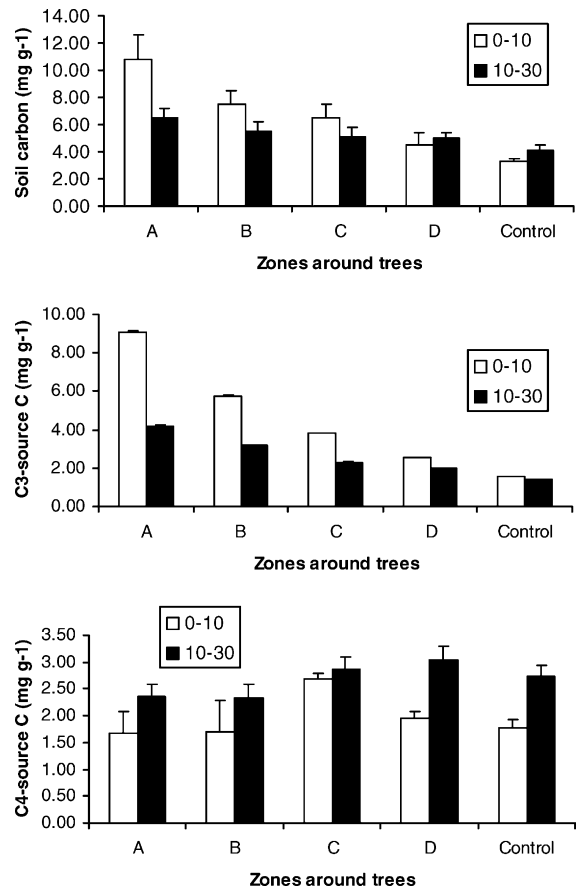

Figure 2. C_3 and C_4 -derived C contributions to soil carbon building up under karité (*Vitellaria paradoxa*) in a parkland system in Saponé, Burkina Faso; Distance from tree trunk: Zone A = 0 to 2 m from the trunk, Zone B = from 2 m to half diameter of the crown, Zone C = from half diameter to the edge of the crown, Zone D = from the edge of the crown to 2 m outside of the crown, Control = open area; Soil depth: 0–10 = soil depth 0–10 cm, 10–30 = soil depth 10–30 cm.

carbon according to zones for both soil layers, nevertheless their contribution on average for the two soil layers increased from zone A ($2.01 \pm 0.22 \text{ mg g}^{-1}$) to zone C ($2.78 \pm 0.22 \text{ mg g}^{-1}$) and thereafter decreased going to the open area ($2.26 \pm 0.21 \text{ mg g}^{-1}$). Apart from zone C, the two other zones underneath tree crown showed lower values of C_4 plants contribution to SOC compared to the two zones outside the influence of tree crown (zones D, Control plot).

Under *néré*, a significant ($p < 0.01$) decreasing trend in SOC going from tree trunk to the open area was observed for zones whereas no significant difference was found between layers (Figure 3). In turn, $\delta^{13}\text{C}$ values revealed a significant increasing pattern going from tree trunk to the open area and from the upper layer to the lower layer (both $p < 0.001$). Consequently the values of both C_3 contribution to soil carbon in zones decreased significantly from tree trunk to the open area both for the upper 0–10 cm layer ($p < 0.001$) and for the lower 10–30 cm layer ($p < 0.01$). This parameter significantly also decreased with soil depth ($p < 0.01$). In reverse, layer 10–30 cm ($2.82 \pm 0.16 \text{ mg g}^{-1}$) displayed significantly higher C_4 plants contribution to SOC compared to the upper layer ($2.33 \pm 0.20 \text{ mg g}^{-1}$) ($p < 0.05$). Again as in *karité*, no significant difference was found in the contribution of C_4 plants to soil carbon under *néré* according to zones for both soil layers (Figure 3). However, the values of this variable on average for the two soil layers increased from tree trunk ($2.44 \pm 0.30 \text{ mg g}^{-1}$) to zone D ($2.76 \pm 0.22 \text{ mg g}^{-1}$) and thereafter slightly decreased in the control plot ($2.70 \pm 0.29 \text{ mg g}^{-1}$). Thus all zones underneath trees showed lower values of C_4 plants contribution to soil carbon compared to the two zones outside (zones D, Control plot).

In any case of the 2 modalities used to establish the balance of *karité* and *néré*-derived C, the relative contribution of *karité* was higher than that of *néré* because of the higher abundance of *karité* compared to *néré* (Table 2).

Discussion

In one hand, crop materials showed $\delta^{13}\text{C}$ values two times higher compared to those of the 2 tree species because of the natural isotopic difference between C_3 and C_4 vegetation in relation with their

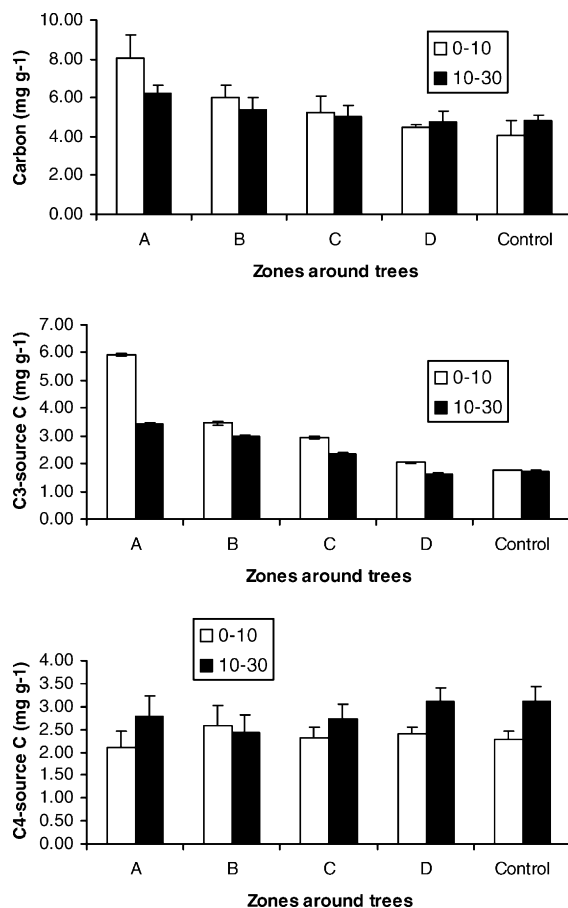

Figure 3. C_3 and C_4 -derived C contributions to soil carbon building up under *néré* (*Parkia biglobosa*) in a parkland system in Saponé, Burkina Faso; Distance from tree trunk: Zone A = 0 to 2 m from the trunk, Zone B = from 2 m to half diameter of the crown, Zone C = from half diameter to the edge of the crown, Zone D = from the edge of the crown to 2 m outside of the crown, Control = open area; Soil depth: 0–10 = soil depth 0–10 cm, 10–30 = soil depth 10–30 cm.

Table 2. Balance of *karité* and *néré*-derived C in upper 0–30 cm layer at the landscape scale in an agroforestry parkland system in Saponé, Burkina Faso.

Modalities	Karité-source C (kg ha ⁻¹)	Néré-source C (kg ha ⁻¹)	Total karité and néré-source C (kg ha ⁻¹)
1	546	226	772
2	787	247	1034

Modality 1, tree-derive C under tree crown in zones A, B, and C; modality 2, tree-derive C upto 2 m outside tree crown in zones A, B, C and D.

different photosynthetic pathways (Andriulo et al. 1999). In another hand, leaves and roots of karité displayed $\delta^{13}\text{C}$ values higher than those of the leaves and roots of néré. The difference in $\delta^{13}\text{C}$ in the materials of the 2 species may be due to different metabolisms for water linked to the stomatal closure or a genetically difference in fractionation associated with stomatal closure. Eventhough no data are available for karité with this respect, Osonubi and Fusehun (1987), and Teklehaimanot et al. (1998) found that transpiration of *P. biglobosa* is under a high degree of stomatal control associated with a high tissue capacitance and internally stored water, which can be used during periods of rapid transpiration. The difference may stem from different reallocations of carbon just before leaf abscission as the leaves used in the present study are senescent ones. This hypothesis may stand true because Bayala et al. (2003) found higher carbon content in néré 'young' leaves of pruned materials ($503.9 \pm 2.1 \text{ mg g}^{-1}$) compared with karité leaves ($484.4 \pm 5.0 \text{ mg g}^{-1}$) whereas in the present study with abscised leaves the opposite was found. Finally the difference in lipid content (which are currently depleted by as much as 10%) is another candidate for the explanation of this difference, which was not investigated here.

Despite the difference in $\delta^{13}\text{C}$ between the materials of the two species, soil carbon contents were not significantly different in the influence zones of the two species. Nevertheless higher soil carbon content under karité is consistent with the fact that its material showed higher values in $\delta^{13}\text{C}$ and has higher carbon content than that of néré. These findings are slightly different from those of Bayala et al. (2002) who found 5.64 ± 0.48 and $5.96 \pm 0.49 \text{ mg g}^{-1}$ of carbon for the 0–10 cm soil depth under karité and néré, respectively. Such differences may be due to sampling method, core sampling in discrete points having been used in the two studies.

Soil carbon contents were higher under trees compared with the open area showing the important contribution of trees to soil carbon contents and that may partly explain the lower soil bulk density under trees compared to the open area (Table 1). For the same reason soil bulk density was lower in the upper layer compared to the lower layer (Table 1). This higher SOC under tree and in the upper layer may also explain their

higher pH values compared to the open area and the lower layer, respectively (Table 1).

C_4 derived carbon was less variable ($2\text{--}3 \text{ mg g}^{-1}$) along the transect going from tree trunk to the open area. To this amount was superposed the C_3 -derived carbon with an increasing trend going from the open area to tree trunk. This impact of trees on soil carbon content is in line with the lower values in $\delta^{13}\text{C}$ of soil under trees compared to the $\delta^{13}\text{C}$ values of soil in the open area. These results corroborate those of Nyberg and Hogberg (1995) who recommended ^{13}C natural abundance as a particularly sensitive indicator of the influence of trees in soil organic matter. The higher soil carbon content in 10–30 cm depth compared to 0–10 cm depth in zone D and control may stem from the fact that either the priming effect on ancient C_4 -derived carbon is high and equivalent for all zones in the upper 0–10 cm or the priming effect is lower in 10–30 cm layer of zones D and control because of lower organic restitutions at that depth.

Karité-derived carbon was higher than that of néré at landscape scale because this species was more abundant in tree samples used with 4 trees ha^{-1} for karité against 1 tree ha^{-1} for néré (Bayala 2002). Moreover, Karité and néré-derived C were underestimated in the present study because mature trees, which were ≥ 30 cm in diameter, were used thus excluding trees with lower stem diameters. In fact, the actual densities of trees were 9.1 trees ha^{-1} for karité and 1.2 trees ha^{-1} for néré (Bayala 2002). Tree-derived carbon was higher in the upper layer and this is consistent with the fact soil carbon in zones under tree influence (A, B, C) was higher in the upper soil layer compared with the lower layer (Figures 1 and 2). These findings corroborate those of Manjaiah et al. (2000) who found that irrespective of the cropping system, approximately 58.4, 25.7, and 15.9% of the carbon was distributed in 0–15, 15–30, and 30–60 cm depths, respectively. In another hand, C_4 -derived carbon was higher in the lower layer in line with the higher soil carbon content found in the lower layer in zones outside tree crown (D and Control). This trend suggests that C_4 materials may be easily decomposable with a migration of soluble carbon down soil profile because the maximum root density of crops was found in 0–10 cm layer in these systems (Bayala et al. 2004). Besides, feeding activity of soil invertebrates and

microbial respiration were shown to change natural abundance of ^{13}C of the organic matter in a range of 1–3‰ with soil depth (Boutton 1996; Santruckova et al. 2000). Furthermore, the older organic carbon deeper in the profile has been exposed to decomposer activity for a longer period of time than the younger organic carbon near the soil surface, and therefore, should have larger $\delta^{13}\text{C}$ values that reflect the cumulative effects of this activity (Boutton 1996; Balesdent and Mariotti 1996). According to the latter hypothesis, the little higher amount of C_4 -derived C in the deeper layer would be partly apparent, due to the uncertainty of the isotopic composition of the C_4 -derived source.

Higher soil fertility has been seen as controversial issue because trees may have simply grown in spots of higher fertility. The present study has proven that trees contribute to the increase and maintenance of soil carbon content showing their importance in carbon sequestration in semi-arid zones where soil carbon is also a major factor controlling soil fertility both for nutrients release and soil organic matter formation.

Conclusions

In summary, we found that soil carbon content was higher under both karité and néré species compared to the open area. The results also showed that the higher carbon under trees is due to the direct positive impact of trees in parkland systems on soil organic matter formation. Such results are very important for semi-arid zones where bush clearing and transformation into farmed fields is expanding with the increase in population pressure. Eventhough it can be argued that these trees are simply concentrating elements in their surroundings their role in avoiding losses of elements from the system is not negligible and should be considered. However, because in the parkland systems the level of organic matter restitutions is low (removal of crop residues and burning of tree litter), balanced fertilisation, residue management and cultivation practices that conserve soil organic matter need to be developed to maintain soil fertility. To develop such techniques, there is a need for continued monitoring of long term effects of trees to soil organic matter formation as well as the effects of this SOM in soil

fertility in relation to different cropping systems for sustainable production. Moreover, the challenge of maintaining the quality of the soil resource in agriculture of semi-arid zones is as great as the problem of increasing atmospheric concentration of CO_2 due to total removal of trees in some cropping systems or mismanagement of tree litter in systems where they are preserved.

Acknowledgements

This study was funded by the International Atomic Energy Agency, through the project: Lutte contre la desertification au Sahel. We wish to thank the farmers in Saponé for their permission and participation in the field experiment. We also wish to thank Koté Lansina and Belem Achille for field assistance. Anonymous reviewers helped in improving the draft and we want to thank them.

References

- Andriulo A., Guérif J. and Mary B. 1999. Evolution of soil carbon with various cropping sequences on the rolling pampas – Determination of carbon origin using variations in natural ^{13}C abundance. *Agronomie* 19: 349–364.
- Balesdent J. and Mariotti A. 1996. Measurement of soil organic matter turnover using ^{13}C natural abundances. In: Boutton T.W. and Yamasaki S.I. (eds), *Mass Spectrometry of Soils*. Marcel Dekker Inc., New York, pp. 83–111.
- Balesdent J., Wagner G.H. and Mariotti A. 1988. Soil organic matter turnover in long-term field experiments as revealed by carbon-13 natural abundance. *Soil Sci. Soc. Am.* 52: 118–124.
- Bationo A. and Buerkert A. 2001. Soil organic carbon management for sustainable land use in Sudano-Sahelian West Africa. *Nutr. Cycl. Agroecosys.* 61: 131–142.
- Bayala J. 2002. Tree crown pruning as a management tool to enhance the productivity of parklands in West Africa. PhD Thesis, University of Wales, Bangor, UK.
- Bayala J., Mando A., Ouedraogo S.J. and Teklehaimanot Z. 2003. Managing *Parkia biglobosa* and *Vitellaria paradoxa* prunings for crop production and improved soil properties in the Sub-Saharan zone of Burkina Faso. *Arid Land Res. Manage.* 17: 283–296.
- Bayala J., Teklehaimanot Z. and Ouedraogo S.J. 2004. Fine root distribution of pruned trees and associated crops in a parkland system in Burkina Faso. *Agroforest. Syst.* 60: 13–26.
- Bayala J., Teklehaimanot Z. and Ouedraogo S.J. 2002. Millet production under pruned tree crowns in a parkland system in Burkina Faso. *Agroforest. Syst.* 54: 203–214.
- Belsky A.J. and Amundson R.G. 1998. Influence of savannah trees and shrubs on understorey grasses and soils: new directions in research. In: Bergstrom L. and Kirchman H. (eds.),

- Carbon and Nutrient in Natural and Agricultural Tropical Ecosystems. CAB-International, Wallingford, UK, pp. 153–171.
- Boutton T.W. 1996. Stable carbon isotope ratios of soil organic matter and their use as indicators of vegetation and climate change. In: Boutton T.W. and Yamasaki S. (eds), *Mass Spectrometry of Soils*. Marcel Dekker Inc., New York, USA, pp. 47–82.
- Breman H. and Kessler J.J. 1995. Woody Plants in Agro-ecosystems of Semi-arid Regions (with an Emphasis on the Sahelian Countries). Springer-Verlag, Berlin, Germany.
- Brouwer J., Fussell L.K. and Herrmann L. 1993. Soil and crop growth micro-variability in the West African semi-arid tropics: a possible risk-reducing factor for subsistence farmers. *Agr. Ecosyst. Environ.* 45: 229–238.
- Diels J., Vanlauwe B., Sanginga N., Coolen E. and Merck R. 2001. Temporal variations in plant $\delta^{13}\text{C}$ values and implications for using the ^{13}C technique in long-term soil organic matter studies. *Soil Biol. Biochem.* 33: 1245–1251.
- Dommergues Y.R. 1987. The role of biological nitrogen fixation in agroforestry. In: Stepler H.A. and Nair P.K.R. (eds), *Agroforestry: A Decade Of Development*. ICRAF, Nairobi, Kenya, pp. 245–271.
- FAO. 1988. Revised legend of soils map of the world 1/5 000 000. *Soils Resources Report 60*. FAO-Rome, Italy.
- Hall J.B., Aebischer D.P., Tomlinson H.F., Osei-Amaning E. and Hindle J.R. 1996. *Vitellaria paradoxa*. A Monograph. School of Agricultural and Forest Sciences, University of Wales, Bangor, UK.
- Hall J.B., Tomlinson H.F., Oni P.I., Buchy M. and Aebischer D.P. 1997. *Parkia biglobosa*. A Monograph. School of Agricultural and Forest Sciences, University of Wales, Bangor, U.K.
- Hopkins H.C. and White F. 1984. The ecology and chorology of *Parkia* in Africa. *B. Jardin Botanique Naturelle Belgique* 54: 235–266.
- Lal R. 2002. The potential of soils of the tropics to sequester carbon and mitigate the greenhouse effect. *Adv. Agron.* 76: 1–30.
- Manjaiah K.M., Voroney R.P. and Utpal Sen. 2000. Soil organic carbon stocks, storage profile and microbial biomass under different crop management systems in a tropical agricultural ecosystem. *Biol. Fert. Soils* 31: 273–278.
- Maydell H.J. von 1983. Arbres et arbustes du Sahel. Leurs caractéristiques et leurs utilisations. GTZ, Eschborn, Germany.
- Nyberg G. and Hogberg P. 1995. Effects of young agroforestry trees on soils in on-farm situations in western Kenya. *Agroforest. Syst.* 32: 45–52.
- Osonubi O. and Fusehun F.E. 1987. Adaptation to soil drying in woody seedlings in African locust bean (*Parkia biglobosa* (Jacq.) Benth). *Tree Physiol.* 3: 321–329.
- Sanchez P.A., Buresh R.J. and Leakey R.R.B. 1997. Trees, soils, and food security. *Phil. Trans. R. Soc., Lond B.*, pp. 949–961.
- Santruckova H., Bird M.I., Frouz J., Sustr V. and Tajovsky K. 2000. Natural abundance of ^{13}C leaf litter as related to feeding activity of soil invertebrates and microbial mineralisation. *Soil Biol. Biochem.* 32: 1793–1797.
- Sivakumar M.V.K. and Gnomou F. 1987. Agroclimatologie de l'Afrique de l'Ouest: le Burkina Faso. Bulletin d'information n°23. ICRISAT, Patancheru, Andhra Pradesh, Inde.
- Teklehaimanot Z., Lanek J. and Tomlinson H.F. 1998. Provenance variation in morphology and leaflet anatomy of *Parkia biglobosa* and its relation to drought tolerance. *Trees* 13: 96–102.
- Tomlinson H., Traore A. and Teklehaimanot Z. 1998. An investigation of root distribution of *Parkia biglobosa* in Burkina Faso, West Africa, using a logarithmic spiral trench. *Forest Ecol. Manage.* 107: 173–182.
- Van Noordwijk M. and Ong C.K. 1999. Can the ecosystem mimic hypotheses be applied to farms in African savannahs?. *Agroforest. Syst.* 45: 131–158.

Mineral fertilizers, organic amendments and crop rotation managements for soil fertility maintenance in the Guinean zone of Burkina Faso (West Africa)

B.V. Bado¹†, A. Bationo², Lompo, F³, M.P. Cescas⁴ and, M.P Sedogo³

¹INERA, Centre Régional de Recherche Agronomique de Farakô-Ba, P. O. Box 910 Bobo-Dioulasso, BURKINA FASO; ²The Tropical Soil Biology and Fertility Institute of CIAT, P. O. Box 30677, 00100, Nairobi, KENYA; ³INERA, CREAf de Kamboinse, 01 BP 476 Ouagadougou, BURKINA FASO; ⁴Département des Sols et Génie Agroalimentaire (FSSA), 2219 Comtois, Université Laval Ste Foy Québec (QC) G1K 7P4 CANADA

Abstract

The effects of cowpea (*Vigna unguiculata*) and groundnut (*Arachis hypogea*) on succeeding sorghum yields, soil mineral nitrogen and N recoveries were studied during three years (2000 to 2002) in a weakly acid Ultisol of the agronomic research station of Farakô-Ba located in the Guinean zone of Burkina Faso. A field agronomic experiment with a factorial 3×4 design of three crop rotations (cowpea-sorghum, groundnut-sorghum and sorghum-sorghum) as first factor and four fertilizer treatments (PK fertilizer, NPK, NPK+ Manure and control) as second factor in a split plot arrangement with four replications.

Highest yields were obtained when sorghum was rotated with legumes while lowest yields were obtained in mono cropping of sorghum. Compared to mono cropping, sorghum could produced 2.9 and 3.1 times more grain yields when it was rotated with groundnut or cowpea respectively. A better use of fertilizer N was observed in legume-sorghum rotations. In continuous sorghum, fertilizer N use efficiency (NUE) was 20%. But in Cowpea-Sorghum and Groundnut-Sorghum rotations, NUEs were 28 and 37% respectively. Legume-sorghum rotations increased soil mineral nitrogen. The soils of legume-sorghum rotations provided more nitrogen to succeeding sorghum compared to mono cropping of sorghum and the highest total N uptake by sorghum was observed in legume-sorghum rotations

Key words: Cowpea, crop rotation, groundnut, fertilizer, legume, nitrogen

Introduction

Nutrient deficiencies, mainly nitrogen (N) and phosphorous (P) are the main soil fertility constraints limiting crop yields in West Africa. Despite the recognized need to apply nutrient inputs such as chemical fertilizers for obtaining high yields, their use in West Africa is limited by several factors such as the lack of capital investment and financial credit and other socio-economic factors. Affordable and efficient means of improving soil fertility and productivity are therefore,

necessary. N₂-fixing legume crops such as groundnut (*Arachis hypogea* L.) and cowpea (*Vigna unguiculata* (L) Walp) are reported to improve soil fertility of cropping systems as a consequence of N supplied by legumes via biological nitrogen fixation (Bagayoko et al., 2000; Bationo and Ntare, 2000). This could be easily demonstrated in cropping systems where legume residues are recycled in soil. However at the end of each rainy season, legume residues are mainly exported for animals feeding. Thus, the total N yield and the quantity of nitrogen fixed by legume crops do not reflect their real contribution to improve soil nitrogen status. Considering that the legume shoots are exported and used to feed livestock but not incorporated in the soil as green manure, the N input effect of legume crops

* Corresponding author: Boubié Vincent Bado, Tel: 226 97 33 78, Fax: 226 97 01 59, E-mail: Vincent.Bado@Coraf.Org

on the succeeding crops could be overestimated when N fixed in the above-ground is considered. N₂-fixing legumes may also provide nitrogen to the subsequent crops through the fallen senescent leaves and below ground parts. However, the N effect alone cannot completely explain the positive effects of legumes on the succeeding crop yields. For instance, legume yields and N₂-fixation are also affected by soil fertility status and fertilizer applications.

In Rhizobium-Legume symbiosis, both Rhizobium and host plant (legume) are affected by soil fertility status and fertilizer applications, if any. It's also well known that many legume plants can efficiently use phosphorus from high P retention soils through their abilities to dissolve P strongly fixed by Fe and Al in mineral acid soils (Nagarajah et al., 1970; Subbarao et al., 1997). Soil acidity (and Al toxicity) is also a limiting factor to crop production in weakly acid low buffered soils affecting biological nitrogen fixation by legume crops. As a source of nutrients, organic manure can be used for soil acidity correction.

This research aims to investigate different management options of legume-sorghum rotations and fertilizer applications to improve soil fertility and cropping system productivity.

Methodology

A field experiment was carried out at the agronomic research station of Farakô-Ba (4° 20' West, 11° 6' North and 405 m altitude above sea level), located in the Guinean savannah zone of Burkina Faso. This agro-ecological zone has one rainy season per year, starting in May-June and ending in October. A factorial of 3 × 4 experiment in a split plot experimental design with randomised block arrangement and four replications. The experiment was carried out during three seasons (2000–2002). Each main plot was split in 4 sub plots for different fertilization treatments (PK, NPK, NPK+Manure and control) employed as second factor. Rotation treatments (first factor) were randomised in the blocks and fertilization treatments (second factor) were randomised in the sub plots.

Improved varieties of sorghum, groundnut and cowpea were used. The list of crops, varieties, planting densities and doses of mineral fertilizer by crops is presented on Table 1. Mineral NPKS fertilisers were applied at sowing on all crops. At 40 days after sowing, complementary dose of nitrogen in the form of urea

was applied to sorghum. To the manure containing treatments, three tonnes per hectare of air-dried cattle manure or compost were applied. Cattle manure contained 1.8, 18.40, 0.31 and 0.16% of N, C, P and K. Legume crops were not inoculated. The experiment was laid down on a six years old fallow area. The soil was an Ultisol, a weakly acid sandy soil with low clay and organic carbon contents. Available P (P-Bray I), Ca, Mg, exchangeable K and exchange capacity were very low (Table 2).

Soil mineral nitrogen (NH₄⁺ + NO₃⁻) was measured at the start of the second year of cultivation (2001). Soil samples were taken in the first 20 cm layer at sowing and seven days after sowing. Mineral N was extracted with 1M KCl solution and measured by colorimetric method (Keeney, 1982). Fertilizer and soil nitrogen recoveries by sorghum was studied by isotopic dilution method on the three rotations and three fertilization regimes. Fourteen kg N ha⁻¹ of urea fertiliser with 5 atomic % ¹⁵N excess were applied at sowing in the isotope micro plots of 3.2m × 1.6m (5.12 m²) delimited in the sub plots. The total above parts of plants were harvested at physiological maturity. Plant samples were dried at 60°C during 72 hours, ground and ¹⁵N atomic excess was determined by mass spectrometry at the IAEA Seibersdorf Laboratory. Indirect method was used for N recovery studies. Labelled urea with ¹⁵N was used as tracer for N recoveries assessment. Nitrogen Fertilizer Use Efficiency (NUE) was calculated using the percentage of N derived from fertiliser (Ndff) and the total N applied by fertilization treatment (Menzel and Smith 1984)

$$\text{NUE} = (\text{Ndff} \cdot \text{kg ha}^{-1} / \text{N applied} - \text{kg ha}^{-1}) \times 100 \quad (1)$$

Soil pH was measured in 1 N KCl using a 2:1 solution to soil ratio and exchangeable acidity was measured as described by McLean (1982). Organic carbon was measured by the wet chemical digestion procedure of Walkley and Black (1934). Total nitrogen was determined by the Kjeldahl procedure. Exchangeable bases (Ca, Mg, K and Na) were displaced with Ammonium acetate. Calcium and Mg were determined by atomic absorption spectrophotometry, while K and Na were determined using flame photometry. Effective Cation Exchange Capacity of the soil (ECEC) was calculated by the total exchange bases. Available phosphorus was determined using Bray I method (Fixen and Grove 1990).

Table 1. List of crops, varieties, planting densities and doses of mineral fertilizer applications by crops.

Crops	Scientific names	Name of varieties	Plant densities (plants ha ⁻¹)	NPKS fertilizer applications (kg ha ⁻¹)			
				N	P	K	S
Sorghum:	<i>Sorghum bicolor</i>	Gnofing	62500	37	10	11	6
Groundnut	<i>Arachis hypogaea</i>	RMP 91	62500	14	10	11	6
Cowpea	<i>Vigna unguiculata</i> (L.) Walp.	KVX-61-1	125000	14	10	11	6

Table 2. Main physico-chemical characteristics of the original soil (0–20 cm layer) of Farako-ba in 2001.

Clay (%)	7	pH H ₂ O	6.5
Sand (%)	74	pH KCl	5.6
Silt (%)	19	Ca ⁺⁺ (cmol ⁺ kg ⁻¹ soil)	1.08
Organic C (%)	0.67	K ⁺ (cmol ⁺ kg ⁻¹ soil)	0.02
Total N (mg kg ⁻¹)	409	Mg ⁺⁺ (cmol ⁺ kg ⁻¹ soil)	0.46
Total P (mg kg ⁻¹)	69.8	ECEC (cmol+ kg ⁻¹ soil)	1.82
Available-Bray I (mg kg ⁻¹)	6.6	pH H ₂ O	6.5
Available K (mg kg ⁻¹)	531		

Results and discussions

Legume yields

High yields of legumes were observed during the first year (Figure 1). But legume yields decreased during the last two years. This can be explained by the effect of the six years old fallow that have been used, leading to high yields during the first year. Without fertiliser applications, the grain yields of the two legumes were very low. PK fertilization alone didn't increase legume yields. However, NPK fertilizer significantly increases grain yields, indicating that in spite of the ability of legume to fix atmospheric N, a low quantity of starter chemical N fertiliser is necessary to improve legume yields. Compared to NPK fertilizer alone, the addition of manure did not significantly increase legume grain yields.

Sorghum yields

During the first season (absence of rotation effect), only the effects of fertilizers were measured. The rotation effects were assessed during the last two years (2001 and 2002). Sorghum yields were affected by fertilizer applications and rotations (Table 3). But during the last two years, interactions were not observed between the two factors, indicating that rotation effects were not influenced by fertilizer applications and conversely. Without fertilizer applications, sorghum

grain yields were very low during the last two years. But in the first year, sorghum produced high yields even fertilizers were not applied. This is probably due to the positive effects of fallow in the first year of cultivation. Chemical NPK fertilization alone increased sorghum grain yields because of the low soil fertility, leading to good responses to fertilizer applications (Berger et al., 1987; Pieri, 1989; Bationo and Mokwunye, 1991a; Bado et al., 1997). But NPK fertilizer applications with manure produced higher sorghum yields. Similar results on the beneficial effects of chemical and organic fertilizers on crop yields have been reported, though they are usually attributed to the role of organic materials on both soil acidity correction and source of nutrients (Pichot et al., 1981; Bationo and Mokwunye, 1991b; Bado et al., 1997).

Continuous cultivation of sorghum produced the lowest yields during the two years (Table 3). But when sorghum was cultivated in rotation with groundnut or cowpea, sorghum produced highest yields and the effects of legume-sorghum rotations increased over years. In year 2001, groundnut-sorghum and cowpea-sorghum rotations increased sorghum grain yields by 60 and 96% respectively compared to continuous sorghum. In 2002, groundnut-sorghum and cowpea-sorghum rotations produced 2.9 and 3.1 times more grain yields respectively than mono cropping of sorghum. Beneficial effects of N₂-fixing legumes on succeeding crops are been reported by many workers (Peoples et al., 1995; Wani et al., 1995; Chalk, 1998;

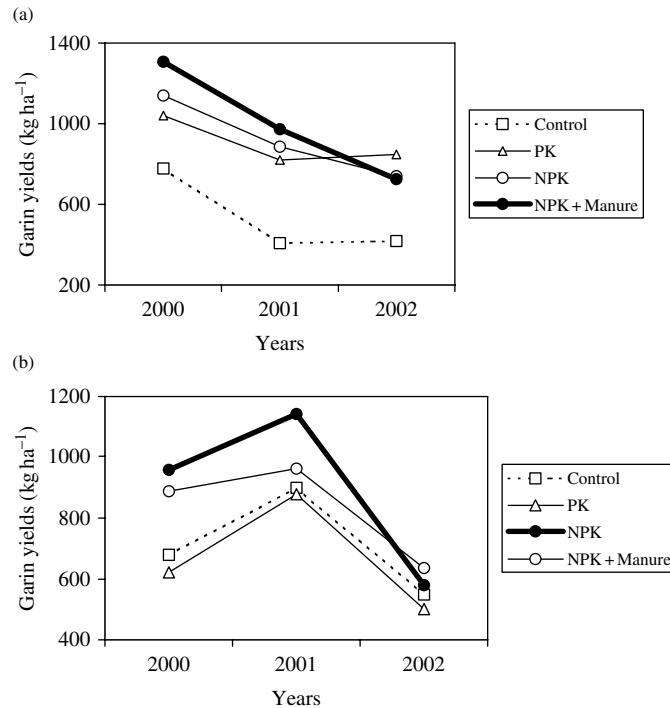

Figure 1. Effects of fertilizer applications on (a) cowpea and (b) groundnut grain yields during 3 years (2000–2002) at Farakô-Ba.

Table 3. Effects of crop rotations and fertilization treatments on succeeding sorghum grain yields (kg ha^{-1}) during three years (2000 to 2002).

		Years			Means	
		2000	2001	2002	Kg ha^{-1}	% of control
Rotations	Groundnut-Sorghum	na	1626 ^b	1826 ^b	1726 ^b	209
	Cowpea-Sorghum	na	1995 ^a	1987 ^a	1991 ^a	241
	Sorghum-Sorghum	na	1018 ^c	636 ^c	827 ^c	100
Fertilization	NPK	1487 ^b	1553 ^b	1574 ^b	1538 ^b	163
	NPK+Manure	1779 ^a	1876 ^a	1933 ^a	1863 ^a	197
	PK	1096 ^c	1387 ^{bc}	1340 ^c	1274 ^c	135
	Control	1092 ^c	864 ^d	881 ^d	946 ^d	100

Values affected by the same letter in the same column are not significantly different at $p < 0.05$, according to Fisher's test; na: Not applicable.

Bagayoko et al., 2000; Kouyaté et al., 2000). Peoples and Crasswell (1992) reported that in legume-cereal rotations, legumes can increase cereal yields from 50 up to 350%. In the semi-arid zone of West Africa, Bationo and Ntare (2000) found that cowpea increased pearl millet yields from 58 to 100%. The positive effects of legume on the increase of succeeding crop yields is mainly attributed to BNF inputs leading to soil fertility improvement for the succeeding non-fixing crops. The N effects of legume are likely to occur but other effects

related to the legumes themselves, soil and fertilizer N utilisation can interact with these N-effects.

Soil mineral N and N recoveries

Soil N mineral estimation at the start of the season (1 and 7 days after sowing) indicated that N available varied with cropping systems (Table 4). For all crop rotation treatments, soil mineral nitrogen decreased

Table 4. Fertilization and legume-sorghum rotations effects on soil mineral N, fertiliser N use efficiencies (NUE) and total N uptake by the succeeding sorghum crop in 2001.

	Soil mineral N (NH ₄ , NO ₃) (kg ha ⁻¹)		NUE		Total N uptake (Kg ha ⁻¹)	
	At sowing	7 DAS	%	Total	Ndfr	
Rotations						
Groundnut-Sorghum	64 ^a	52 ^{ab}	37 ^a	121 ^a	73	
Cowpea-Sorghum	57 ^{ab}	58 ^a	28 ^b	107 ^b	59	
Sorghum-Sorghum	42 ^c	45 ^c	20 ^c	48 ^c	0	
Fertilization						
NPK	53	48	30	82 ^b	0	
NPK+Manure	58	59	32	110 ^a	28	

Values affected by the same letter in the same column are not significantly different at $p < 0.05$, according to Fisher's test.

Ndfr: Increasing of soil mineral N compared to control treatment (sorghum-sorghum rotation or NPK fertilizer.)

DAS: Days after sowing.

rapidly during the season (data not shown). The first rains of the season induced a resurgence of microbial activity leading to a "mineralization flush" of soil organic nitrogen and increases in mineral N. Soil mineral N decline was due to the decrease in N mineralization, N uptake by plants, N leaching and other N losses.

In spite of those variations, soil mineral N was affected ($P < 0.05$) by crop rotations. But soil mineral N was not affected by fertiliser applications and interactions were not observed between the two factors. Compared to continuous sorghum, the soils of cowpea-sorghum and groundnut-sorghum rotations provided respectively 2.3 and 2.6 times more N to sorghum (Table 4). However, significant differences were not observed between cowpea-sorghum and groundnut-sorghum rotations. Shumba (1990) also found an increase of 32 kg N ha⁻¹ of soil mineral N in cowpea-maize rotation compared to continuous maize cultivation. Similar results have been reported by Wani et al. (1995) and Bationo and Ntare (2000). After the first week, differences were no observed between rotations.

The effects of rotation and fertilisers on N yields increasing were also calculated using sorghum-sorghum rotation or NPK fertilizer as control treatments (Ndfr). Cowpea-sorghum and groundnut rotations increased N providing by soil from 59 to 73 kg ha⁻¹ respectively. At the same time, legume-sorghum rotations increased N fertiliser use efficiency (NUE) compared to continuous sorghum (Table 4). Nitrogen use efficiency increased from 20% in continuous

sorghum to 28 and 37% when sorghum was rotated with cowpea and groundnut respectively. As a consequence of soil mineral N and NUE increasing, total N uptake was also affected by rotations ($P < 0.001$) and fertiliser applications ($P < 0.001$). But, interaction was not observed between the two factors.

Those data clearly indicated that high N uptake in legume-sorghum rotations was explained by the effectiveness of legume-sorghum rotations to provide more N to succeeding sorghum and the better use of N fertiliser applied promoting better plant growth and higher yields. Soils in both cowpea-sorghum and groundnut-sorghum rotations provided more N for succeeding sorghum compared to continuous sorghum. A better use of N fertiliser was particularly observed in cowpea-sorghum rotations leading to higher N uptake and yields of succeeding sorghum compared to groundnut-sorghum rotations. Legume residues probably provided more organic N leading to high mineral N for the succeeding crop (Kurtz et al., 1984; Varvel and Peterson, 1990). High mineral N in the soils where the legume-sorghum rotations were grown could be a consequence of organic N provided by legume residues. Despite the exportation of legumes shoots, the remaining crop residues and the below ground part of legumes can improve organic matter and soil mineral N of the topsoil. Compared to continuous sorghum, the good quality of the legume residues probably contributed to supply more organic N in legume-sorghum rotations leading to an increase of soil mineral N at the beginning of the next season. Giller et al. (1995) estimated that 15 to 20% of the nitrogen of legumes is recycled

for the succeeding crop by legume residues. The better use of N from soil and fertiliser in the legume-sorghum rotations led to high N uptake explaining higher yields of the succeeding sorghum. The positive interaction between organic and mineral N can justify the effectiveness of legume on N uptake by succeeding crops.

Conclusion

Soil fertility of smallholder farmer's systems can be improved by integrated management of the two N₂-fixing legume crops (cowpea and groundnut) and low quantities of mineral fertilizers used by farmers. The two legumes increased fertilizer N recoveries, N uptake and yields of succeeding sorghum. Between the two legumes, cowpea is most efficient than groundnut on succeeding sorghum yield increasing. In legume-sorghum rotations, only the recommended doses of mineral NPK fertilizer can be applied on groundnut and cowpea. Organic manure applications are not necessary on the two legumes. But on the succeeding sorghum, mineral NPK fertilizer can be associated with 3 tonne ha⁻¹ of organic manure.

Acknowledgements

This work has been funded by the National Agricultural Research Institute of Burkina Faso (INERA), the Institute of Tropical Soil Biology (TSBF, institute of CIAT) and the International Atomic Energy Agency (IAEA). The authors are grateful to Dr Bationo, AfNet coordinator and Dr. F. Zapata, Project Officer and the staff of the FAO/IAEA Agriculture and Biotechnology Laboratory at Seibersdorf for their support for the isotopic analyses.

References

- Bado B.V., Sedogo M.P., Cescas M.P., Lompo F. and Bationo A. 1997. Effet à long terme des fumures sur le sol et les rendements du maïs au Burkina Faso. *Cahiers Agricultures* 6 (6): 571–575.
- Bagayoko M., Buerkert A., Lung G., Bationo A. and Römhild V. 2000. Cereal/legume rotation effects on cereal growth in Sudano-Saharan West Africa: soil mineral nitrogen, mycorrhizae and nematodes. *Plant and Soil* 218: 103–116.
- Bationo A. and Mokwunye A.U. 1991a. Role of manure and crop residues in alleviating soil fertility constraints of crop production with special reference to the Sahelian and Sudanian zones of West Africa. *Fertilizer Research* 29: 117–125.
- Bationo, A. and Mokwunye A.U. 1991b. Alleviating soil fertility constraints to increased crop production in West Africa: The experience of the Sahel. In: Mokwunye A. (Ed) *Alleviating soil fertility constraints to increased crop production in West Africa*. Kluwer Academic Publishers, Dordrecht, The Netherlands, pp. 195–215.
- Bationo A. and Ntare B.R. 2000. Rotation and nitrogen fertilizer effects on pearl millet, cowpea and groundnut yield and soil chemical properties in a sandy soil in the semi-arid tropics, West Africa. *Journal of Agricultural Sciences* 134: 277–284.
- Berger M., Belem P.C., Dakouo D. and Hien V. 1987. Le maintien de la fertilité des sols dans l'Ouest du Burkina Faso et la nécessité de l'association agriculture-élevage. *Cot. et Fib. Trop.*; vol.XLII, Fasc 3, pp 10.
- Chalk P.M. 1998. Dynamics of biologically fixed N in legume-cereal rotations: a review. *Aust. J. Res.* 49: 303–316.
- Fixen P.E and Grove J.H. 1990. Testing soil for phosphorus. In: Westerman R.L. (Ed) *Soil Testing and Plant Analysis*. Soil Science Society of America, Madison, WI, pp. 141–180.
- Giller K.E., Mcdonagh J.F., Toomsan B., Limpinuntana V., Cook H.F. and Lee H.C. 1995. Legumes in the cropping systems of North-East Thailand. University of London, UK. Third International Conference on Sustainable Agriculture, Wye College Press, Ashford.
- Keeney D.R. 1982. Nitrogen availability indices. In: Page A.L., Miller R.H. & Keeney D.R. (Eds). *Methods of Soil Analysis. Part II*. (2nd Edn) *Agronomy Monograph No 9*, pp 711–730. Madison, WI: American Society of Agronomy.
- Kouyaté Z., Franzluebbbers-Kathrin; Juo-Anthony S.R. and Hossner-Lloyd R. 2000. Tillage, crop residue, legume rotation and green manure effects on sorghum and millet yields in the semiarid tropics of Mali. *Plant-and-Soil* 225 (1–2): 141–151.
- Kurtz L.T., Boon L.V., Peck T.R. and Hoefl R.G. 1984. Crop rotation for efficient nitrogen production. In: Hauck D. (Ed) *Nitrogen in crop production*, Madison, WI, pp. 295–305.
- Mclean, E. O. 1982. Soil pH and lime requirement. In: Page, A.L., Miller R.H. and Keeney D.R. (eds) *Methods of Soil Analysis* (2nd edn). *Agronomy Monograph No 9*, American Society of Agronomy, Madison, WI, pp 199–223.
- Menzel R.G. and Smith S.J. 1984. Soil fertility and plant nutrition. In: L'Annunziata M.F. and Legg J.O. (ed) *Isotopes and radiation in agricultural sciences Vol 1:1–34*. Soil-Plant-Water Relations. Academic Press, London.
- Nagarajah S.A., Posner M. and Quirk J.P. 1970. Competitive adsorption of phosphate with polygalacturonate and others organic anions on kaolinite and oxide surfaces. *Nature* 228: 83–84.
- Peoples M.B and Crasswell E.T. 1992. Biological nitrogen fixation: Investment, Expectation and actual contribution to agriculture. *Plant and Soil* 141: 13–39.
- Peoples M.P., Herridge D.F. and Ladha J.K. 1995. Biological nitrogen fixation: an efficient source of nitrogen for sustainable agricultural production? *Plant and Soil* 174: 3–28.
- Pichot J., Sedogo M.P. and Poulain J.F. 1981. Évolution de la fertilité d'un sol ferrugineux tropical sous l'influence des fumures minérales et organiques. *Agronomie Tropicale N° 36*: 122–133.
- Pieri C. 1989. Fertilité des terres de savane. Bilan de 30 années de recherche et de développement agricoles au sud du Sahara. Paris, Agridoc-International, 444 p.
- Shumba E.M. 1990. Response of maize in rotation with cowpea to NPK fertilizer in a low rainfall area. *The Zimbabwe-Journal-of-Agricultural-Research* 28 (1): 39–45.

- Subbarao G.V., Ae N. and Otani T. 1997. Genotypic variation in iron and aluminium-phosphate solubilizing activity of pigeon pea root exudates under P deficient conditions. *Soil Science and Plant Nutrition*, 43(2) : 295–305.
- Varvel G.E. and Peterson T.A. 1990. Nitrogen fertilizer recovery by corn in monoculture and rotation systems. *Agron. J.* 82: 935–938.
- Walkley A. and Black J.A. 1934. An examination of the Detjareff method for determining soil organic matter and a proposed modification of the chromatic acid titration method. *Soil Science* 37: 29–38.
- Wani S.P., Rupela O.P. and Lee K.K. 1995. Sustainable agriculture in the semi-arid tropics through biological nitrogen fixation in grain legumes. *Plant and Soil* 174: 29–49.

Effect of planting technique and amendment type on pearl millet yield, nutrient uptake, and water use on degraded land in Niger

D. Fatondji¹, C. Martius^{2,*}, C.L. Bielders³, P.L.G. Vlek², A. Bationo⁴ and B. Gerard¹
¹ICRISAT-Niger, BP 12404, Niamey, Niger; ²ZEF, UNI-Bonn, Walter-Flex-Street 3, D-53113, Bonn, Germany; ³Université catholique de Louvain (ULC), Croix du Sud 2, boîte 2, B-1348, Louvain-la-Neuve, Belgium; ⁴TSBF-CIAT, c/o ICRAF, P.O. Box 30677, Nairobi, Kenya; *Author for correspondence (e-mail: c.martius@uni-bonn.de)

Key words: Agronomic efficiency, Indigenous technology, Nutrient use efficiency, Planting pit, Rainfall use efficiency, Uptake, Zai

Abstract

Due to increased population pressure and limited availability of fertile land, farmers on desert fringes increasingly rely on marginal land for agricultural production, which they have learned to rehabilitate with different technologies for soils and water conservation. One such method is the indigenous zai technique used in the Sahel. It combines water harvesting and targeted application of organic amendments by the use of small pits dug into the hardened soil. To study the resource use efficiency of this technique, experiments were conducted 1999–2000, on-station at ICRISAT in Niger, and on-farm at two locations on degraded lands. On-station, the effect of application rate of millet straw and cattle manure on millet dry matter production was studied. On-farm, the effects of organic amendment type (millet straw and cattle manure, at the rate of 300 g per plant) and water harvesting (with and without water harvesting) on millet grain yield, dry matter production, and water use were studied. First, the comparison of zai vs. flat planting, both unamended, resulted in a 3- to 4-fold (in one case, even 19-fold) increase in grain yield on-farm in both years, which points to the yield effects of improved water harvesting in the zai alone. Zai improved the water use efficiency by a factor of about 2. The yields increased further with the application of organic amendments. Manure resulted in 2–68 times better grain yields than no amendment and 2–7 times better grain yields than millet straw (higher on the more degraded soils). Millet dry matter produced per unit of manure N or K was higher than that of millet straw, a tendency that was similar for all rates of application. Zai improved nutrient uptake in the range of 43–64% for N, 50–87% for P and 58–66% for K. Zai increased grain yield produced per unit N (8 vs. 5 kg kg⁻¹) and K (10 vs. 6 kg kg⁻¹) compared to flat; so is the effect of cattle manure compared to millet straw (9 vs. 4 kg kg⁻¹, and 14 vs. 3 kg kg⁻¹), respectively. Therefore zai shows a good potential for increasing agronomic efficiency and nutrient use efficiency. Increasing the rate of cattle manure application from 1 to 3 t ha⁻¹ increased the yield by 115% TDM, but increasing the manure application rate further from 3 to 5 t ha⁻¹ only gave an additional 12% yield increase, which shows that optimum application rates are around 3t ha⁻¹.

This article has been previously published in the journal "Nutrient Cycling in Agroecosystems" Volume 76 Issues 2–3.

Introduction

Sustainable land use implies harmony between man's use of land and the land's ability to maintain its quality. Once this balance is upset, land degradation occurs (Katyal and Vlek 2000). Agricultural land degradation is one of the major problems facing agricultural production nowadays. According to the Global Land Assessment of Degradation (GLASOD) (Oldeman et al. 1990) 38% of the world's total cropland has been degraded since the 1950s and in Africa, 65% of the cropland is degraded to some extent. As Sundquist (2004) reported that desertification along the Sahara desert proceeds at an estimated 1000 km² every year, these areas are likely to have increased significantly since the GLASOD assessment. In the Sahelian zone, soil fertility restoration through the vegetative fallow system is becoming increasingly ineffective due to population pressure, which leads to shorter fallow periods or simply to land abandonment (Amissah-Arthur et al. 2000). Limited availability of fertile land forces farmers to rely on marginal or even degraded lands for agricultural production.

Zai is one of several techniques available for rehabilitation of degraded lands. To prepare the zai, farmers dig small pits in the soil to collect water, wind-driven soil particles, and plant debris around the plant. About two handfuls (the equivalent to 300 g) of organic amendments such as millet straw, cattle manure or their composted form are typically added to the pits (Roose et al. 1992, 1993; Kaboré 1995; Ouédraogo and Kaboré 1996). The technique thus combines water harvesting with nutrient management practices. As locally available material is used, small-scale farmers who are the major food producers in the Sahel (Roose et al. 1992) are easily able to implement it. The main investment required by the technology is manpower for digging the zai holes, but the work is done during the dry period of the year when the farmers can invest some spare time. Previous studies have shown that zai promotes crop production on highly degraded soils and helps alleviate the adverse effect of dry spells, which are frequent during the cropping period in the Sahel (Roose et al. 1993; Hassan, 1996). However, no attempts have been made to study the resource use efficiency of the technology. To address this

gap, we hypothesized that both the water collected in the pit and the nutrient released from the amendment (which is concentrated at the rooting zone of the crop) induce better plant development and yield, resulting in higher nutrient and water use efficiencies. To address this hypothesis in the present study, experiments were carried out in the Sahelian zone of Niger, on-station under controlled water supply in 1999, and on-farm at two locations during the rainy seasons 1999 and 2000. The objective of the on-station experiment was to determine the optimum application rate of organic amendments for pearl millet (*Pennisetum glaucum*) production as a function of the type of amendment. The objective of the on-farm experiment was to study resource use efficiency of millet under rainfed conditions in the zai system as compared to planting on flat soil.

Material and methods

Site description

The on-station experiment was conducted under controlled water supply at the ICRISAT research station at Sadoré (13°15' N, 2°17' E) in Niger from March to May 1999. Longterm average annual rainfall at this site is 550 mm, which falls between June and September. Monthly temperature varies between 25 and 41 °C. The soils are classified as psammentic paleustalf (West et al. 1984), acidic with relatively high Al saturation and very high sand content (Table 1). The experiment was conducted on a field that had been subject to severe wind and water erosion for a period of 4 years, and that had developed extensive erosion crusts (Casenave and Valentin 1989), locally known as "Gangani", characteristic of severely degraded land.

The two on-farm yield trials were conducted during the rainy seasons 1999 and 2000 at Damari (13°12' N and 2°14' E) and Kakassi (13°50' N and 1°29' E). Long-term average annual rainfall and monthly temperature amplitude at Damari are similar to conditions at the ICRISAT research station. The soil at Damari is classified as kanhaplic Haplustult (Soil Survey Staff 1998). It is acidic, with 84% sand content and relatively low effective cation exchange capacity (ECEC). The vegetation was an open bush with scattered trees.

Table 1. Selected initial soil properties of the experimental fields at Sadoré, Damari and Kakassi, (0–20 cm soil depth).

Soil characteristics	Sadoré	Damari	Kakassi
pH (H ₂ O)	4.5	4.2	6.4
pH (KCl)	3.9	3.9	5.4
Exchangeable base (cmol kg ⁻¹)	0.4	1.7	7.9
Exchangeable acidity (cmol kg ⁻¹)	0.7	1.1	0.04
ECEC ^a (cmol kg ⁻¹)	1.0	2.8	7.9
Al saturation (%)	47	29	0
Base saturation (%)	37	61	99
P-Bray I (mg kg ⁻¹)	2.3	2	0.8
C org (%)	0.1	0.2	0.2
Total N (mg kg ⁻¹)	120	116	169
Bulk density (kg m ⁻³)	1.5	1.6	1.8
Sand (%)	92	84	69
Silt (%)	3	3	6
Clay (%)	5	13	25

^aEffective Cation Exchange Capacity.

The selected field had been left fallow for 3 years prior to the experiment. In addition to small patches of loose sand deposits, which were cropped by the farmer, the field contained large patches of bare crusted soil, which were selected for installing the experimental plots.

Long-term average annual rainfall at Kakassi is 450 mm. Annual temperature variation is in the range of 25–35 °C. The soil is classified as vertic Haplustept (Soil Survey Staff 1998), with almost neutral pH, no exchangeable aluminum and relatively high clay content (Table 1). The vegetation was an open bush with scattered trees. The experimental field was located on bare soil in a fallow, with scattered patches of cropped areas less affected by erosion. The field had been an uncultivated fallow for more than 10 years prior to the installation of the experiment.

Experimental layout

(1) On-station (at Sadoré), the effects of amendment type (millet straw and cattle manure) and rate of application (1, 3, and 5 t ha⁻¹) on dry matter production of millet (*Pennisetum glaucum* L. R. Br) were evaluated in zai pits under controlled irrigation. The field was sprinkler-irrigated uniformly throughout the growing period at a weekly rate of 20 mm. The experimental design was a randomised complete block design (RCBD) + control non-amended pit and a control non-amended flat, replicated four times. A local millet variety ‘Sadoré local’ (120 days growing cycle) was sown on 17 March 1999 and harvested on 25 May before grain production to avoid interference of rain with the treatments, but also due to the photosensitivity of the crop. Therefore only dry matter production was evaluated.

(2) On-farm, the effect of planting technique (planting on flat vs. planting in zai pits) and amendment type (millet straw and cattle manure) on millet growth and development was studied. At both sites, the experimental design was a RCBD + control (no organic amendment) with four replications. The millet variety ‘Sadoré local’ was sown at Damari on 29 June in 1999 and 26 June in 2000 and harvested at maturity (Table 2). At Kakassi a local millet variety ‘Darinkoba’ (120 days to maturity) was sown on 1 July in both years and harvested at maturity (Table 2). In all experiments, planting density was 10,000 pockets per ha. They were thinned to three plants per pocket approximately 3 weeks after planting.

Plant establishment was delayed at Damari in 1999 due to heavy rains (sand covered the young

Table 2. Details experiments at Damari and Kakassi 1999 and 2000.

	Damari		Kakassi	
	1999	2000	1999	2000
Plot size: 6 m × 6 m				
Zai pits digging: 12 May at Damari and 29 May at Kakassi in both years				
Amendment application	24-May	7-Jun	4-Jun	12-Jun
Missing hills re-sowing	14 DAS	10 DAS	15 DAS	13 DAS
Plant thinning	22 DAS	22 DAS	22 DAS	20 DAS

DAS, Days after sowing.

seedlings in the zai), and at Kakassi in 2000 due to dry spells at the beginning of the rainy season.

On-farm, in both years, the rain started at the end of June at Damari (Figure 1a and c) with adequate rain for planting. Cumulative rainfall in both years (499 mm in 1999 and 425 mm in 2000) was below the long-term average (550 mm). At Kakassi it was 397 mm in 1999 and 490 mm in 2000 (Figures 1b and d), compared to the long-term average of 450 mm, with useful rainfall for planting received at the end of June. In both years and particularly in 2000, frequent dry spells (more than 1 week without rain) occurred.

Data collection

At harvest, total dry weight (on-farm and on-station experiments) as well as seed dry weight and harvest index (on-farm only) were recorded. Harvest index is the ratio of grain yield to aboveground dry matter. Grain samples were analysed for N, P and K in both years' on-farm trials. To study crop nutrient uptake during the cropping period in the

dry season trial, whole-plant samples were collected from two pockets in three replications every 3 weeks, starting three weeks after planting. Samples were cleaned, dried at 65 °C for 48 h; weighed and ground to pass a sieve of 1 mm mesh size. Sub-samples of 5 g were analysed for total N, P and K, following a digestion according to the Kjeldahl method (Houba et al. 1995). Total N was determined with an auto-analyzer using the colorimetric method based on the Bertholet reaction. Total P was determined with the colorimetric method based on the phosphomolybdate complex, reduced with ascorbic acid and total K with flame emission spectrophotometry. To study water use, soil moisture profiles were measured weekly at 15 cm intervals down to 240 cm depth using a Didcot neutron probe (Didcot Instrument Company Limited). Two 48 mm inner diameter aluminum access tubes were installed in each plot, one tube between the hills, the other in the pocket close to the plant. At Damari, the depth of the shallowest tube was restricted to 45 cm due to the presence of a lateritic layer, while the deepest reached 300 cm. At Kakassi the depths were, respectively, 100 and 165 cm. The probe had

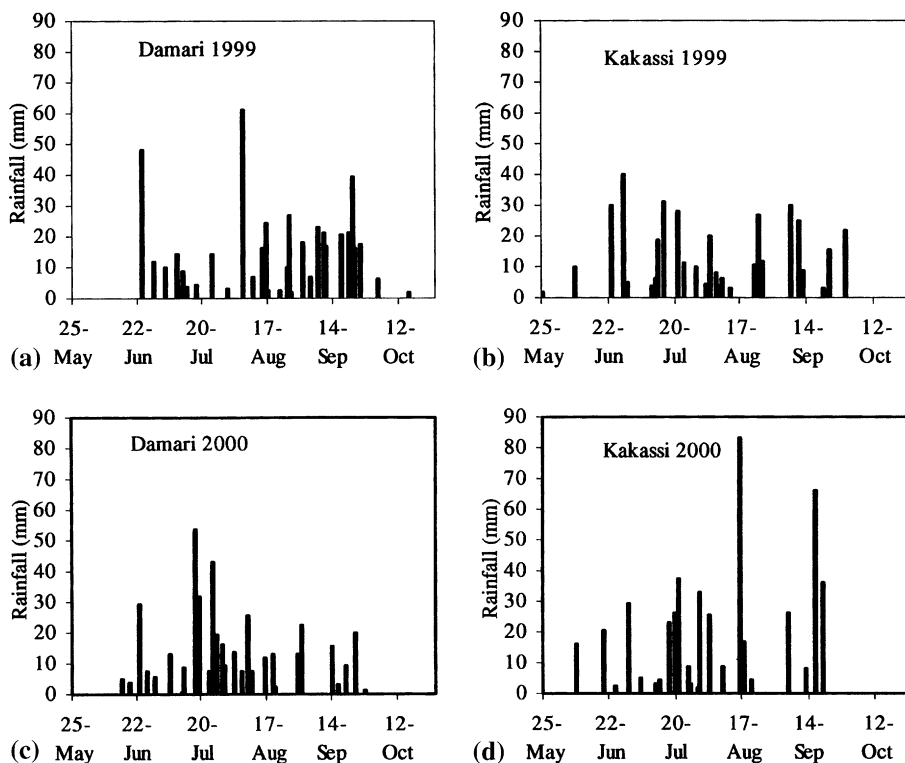

Figure 1. Daily rainfall at the experimental sites. Rainy seasons 1999 and 2000.

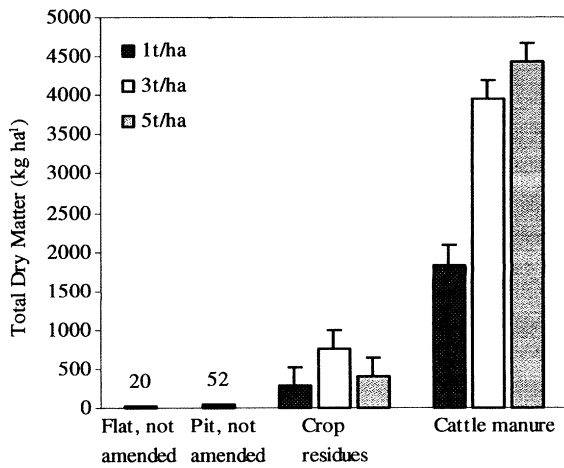

Figure 2. Millet dry matter production as affected by amendment type and rate in the zai system; Sadoré 1999. Error bars are standard error of difference between means.

been calibrated *in-situ* for the soils of the experimental sites applying the gravimetric method. Data of the tubes installed between the millet pockets are reported in this paper.

From the neutron probe data, the volumetric soil water content and the stock of water in the soil profile were calculated. Water use efficiency was calculated as:

$$WUE = Y / \left(\sum (R - \Delta S) \right),$$

where WUE, water use efficiency ($\text{kg mm}^{-1} \text{ha}^{-1}$); Y , yield (kg ha^{-1}) (Total dry matter or grain); ΔS , change in soil water content between two dates of observation (mm); R , total rainfall between two dates of observation (mm).

From the data recorded at maturity the following parameters were calculated:

N, P and K uptake:

$$(C \times D) / 100 (\text{kg ha}^{-1}),$$

where C , nutrient content in millet straw or grain (%) and D , dry matter or grain yield at sampling (kg ha^{-1}).

Agonomic Efficiency (AE):

$$AE = (\Delta \text{yield} / \text{Quantity of nutrient applied}) (\text{kg kg}^{-1})$$

where Δ yield, the difference in yield obtained between the treated plot and the control (no amendment).

Nutrient Utilization Efficiency (NUE) (Christianson and Vlek 1991):

$$NUE = (\text{Yield} / \text{Total nutrient absorbed}) (\text{kg kg}^{-1})$$

where Yield, millet straw or grain yield in (kg ha^{-1}); Total nutrient absorbed, total nutrient uptake in millet straw or grain (kg ha^{-1}).

The statistical analysis was done with the ANOVA procedure of the statistical software GENSTAT® 6.1 (Lawes Agricultural Trust 2000). Due to the large differences between the amended plot and the controls, at a first step a restriction was put on the control plots data to analyse the amended plots. At a second step, the amended plots were restricted to analyse the control plots. The interpretation of results was done accordingly. The data of the on-farm trials were analysed for each site and year individually, and subsequently pooled and analysed as a split plot to compare the effect of the treatments in the two environments for the 2 years.

Results

Dry matter production at Sadoré

On-station, millet total dry matter (TDM) in the non-amended zai pit and the non-amended flat planting was very low (52 and 20 kg ha^{-1} , respectively ($\text{sed} = \pm 32$); Figure 2). Organic amendment application increased TDM production. Cattle manure was more effective than millet straw (3957 vs. 756 kg ha^{-1} – $\text{sed} = \pm 239$ (Figure 2) when applied at 3 t ha^{-1}). Furthermore, millet straw gave highest TDM at 3 t ha^{-1} , while animal manure gave 12% more dry matter at 5 t ha^{-1} .

Grain yield and total dry matter production on-farm

Effect of planting technique. Millet total dry matter (TDM) and grain production on flat planted control plots were very low to moderate at both sites in both years (grain yields 0.9 – 118 kg ha^{-1} ; Table 3). With the zai technique grain yields were 3–4 times higher (and 19 times in one situation),

Table 3. Effect of planting technique on millet grain and dry matter yield in un-amended plots; Damari and Kakassi, rainy season 1999 and 2000; values averaged over all treatments.

Sowing technique	Grain yield (kg ha ⁻¹)				Total dry matter (kg ha ⁻¹)			
	1999		2000		1999		2000	
	Damari	Kakassi	Damari	Kakassi	Damari	Kakassi	Damari	Kakassi
Zai	17	434	19	388	303	2125	213	1938
Flat	0.9	118	6	94	96	752	101	768
Sed(±)	6.4	105.8	10.0	54.8	77.3	405.0	72.8	251.7
Fprob	0.08	0.06	> 0.05	0.013	0.07	0.04	> 0.05	0.007

Sed, standard error of difference between means.

Table 4. Effect of planting technique on millet grain yield and total dry matter production in plots amended with organic matter (average); Damari and Kakassi 1999 and 2000; values averaged over all treatments.

Sowing technique	Grain yield (kg ha ⁻¹)				Total dry matter (kg ha ⁻¹)			
	1999		2000		1999		2000	
	Damari	Kakassi	Damari	Kakassi	Damari	Kakassi	Damari	Kakassi
Zai, amended	662	628	488	637	3096	3800	1824	3593
Flat, amended	416	366	292	389	1881	2382	1346	1704
Sed (±)	142.9	84.1	47.7	143.5	456.9	490.0	135.6	448.2
Fprob	> 0.05	0.012	0.003	> 0.05	0.026	0.018	0.006	0.002

Sed, standard error of difference between means.

illustrating the contribution of the water harvesting effects of the zai technique.

The overall tendency observed across years and sites in the amended plots was that grain yield and total dry matter in the zai were higher than on flat, with the differences in grain yield statistically significant at Kakassi in 1999 and at Damari in 2000 (Table 4), which may be due to the drier conditions in these years that enlarged the positive effect of the zai at the two sites.

Effect of amendment. In both years at both sites, cattle manure significantly increased the positive effect of the zai technique expressed in terms of straw yield, grain yield and total dry matter, but millet straw did not (Figures 3 and 4; Table 5). Millet straw application was more effective at Kakassi than at Damari (Table 5). The difference between both types of amendment was larger at Damari than at Kakassi (Table 5) with a 2- to 5-fold grain yield increase at Kakassi and Damari, respectively, when manure application is compared to millet straw, indicating a better response to manure application on the more degraded soils (Damari). Cattle manure was more effective in

1999 than in 2000 in terms of dry matter production (Table 6).

Zai increased the harvest index mainly in 2000 (Table 7), a year characterized by intermittent dry spells that may have induced poor grain filling in contrast with 1999, a year with relatively better rainfall distribution. The zai was able to alleviate the effect of the frequent dry spells in the rainy season 2000. In addition, the better results of millet straw application at Kakassi compared to Damari may be attributed to the moderate soil fertility level of the soil at Kakassi (Table 1), that may have compensated for the nutrient deficiency in the millet straw applied (Table 8)

Nutrient uptake, nutrient utilization efficiency, and agronomic efficiency

On-station. All parameters were calculated on dry matter basis as the plants were harvested before grain setting. Nutrient uptake increased throughout the cropping period and was higher in manure-amended plots than in plots with millet

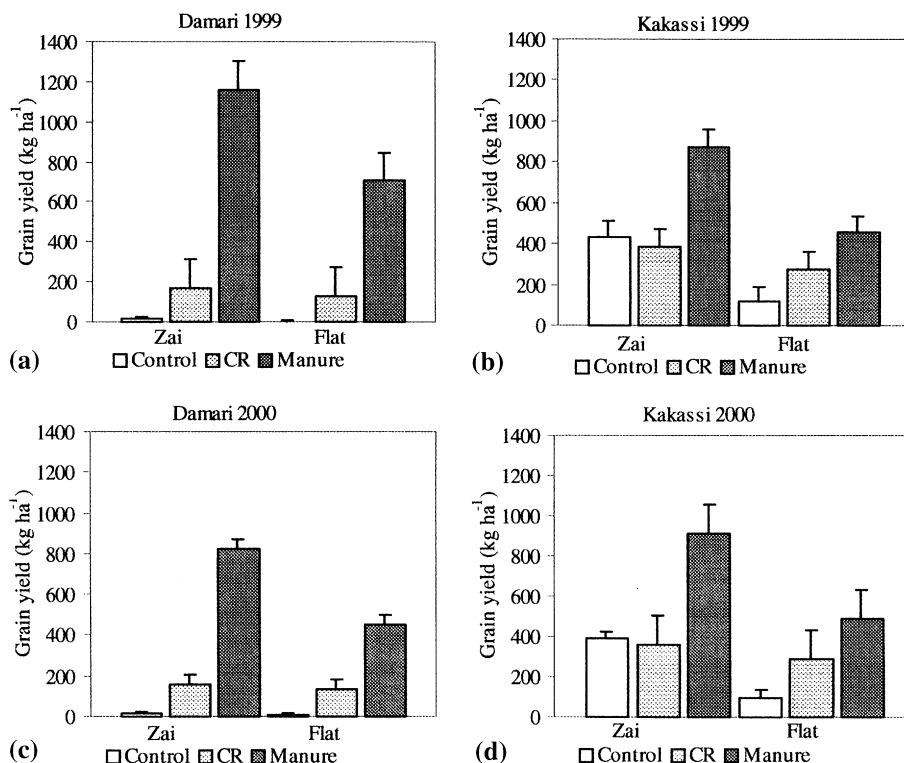

Figure 3. Millet grain yield as affected by sowing technique and amendment type. Damari and Kakassi, rainy seasons 1999 and 2000. CR, millet straw. Error bars are standard error difference between means.

Table 5. Millet production characteristics as affected by amendment type at Damari and Kakassi; values averaged over treatments and years.

Sites	Amendment	Straw yield (kg ha ⁻¹)	Grain yield (kg ha ⁻¹)	Total biomass (kg ha ⁻¹)
Damari	Straw	567	146	839
	Manure	2014	783	3234
Kakassi	Straw	1184	327	1772
	Manure	2735	683	3968
	Sed (\pm)	185.4	79.4	289.0
	Fprob	> 0.05	0.017	> 0.05

Sed, standard error of difference between means.

Table 6. Millet production characteristics as affected by amendment type in 1999 and 2000; values averaged over all treatments and sites.

Year	Amendment	Straw yield (kg ha ⁻¹)	Grain yield (kg ha ⁻¹)	Total biomass ^a (kg ha ⁻¹)
1999	Straw	960	239	1400
	Manure	2882	797	4180
2000	Straw	791	233	1211
	Manure	1867	669	3022
	Sed (\pm)	185.4	79.4	289.0
	Fprob	0.003	> 0.05	0.023

Sed, standard error of difference between means.

^aTotal biomass exceeds the sum of straw yield and grain yield, because it corresponds to the total of straw yield and head yield (the yield of the reproductive part before threshing).

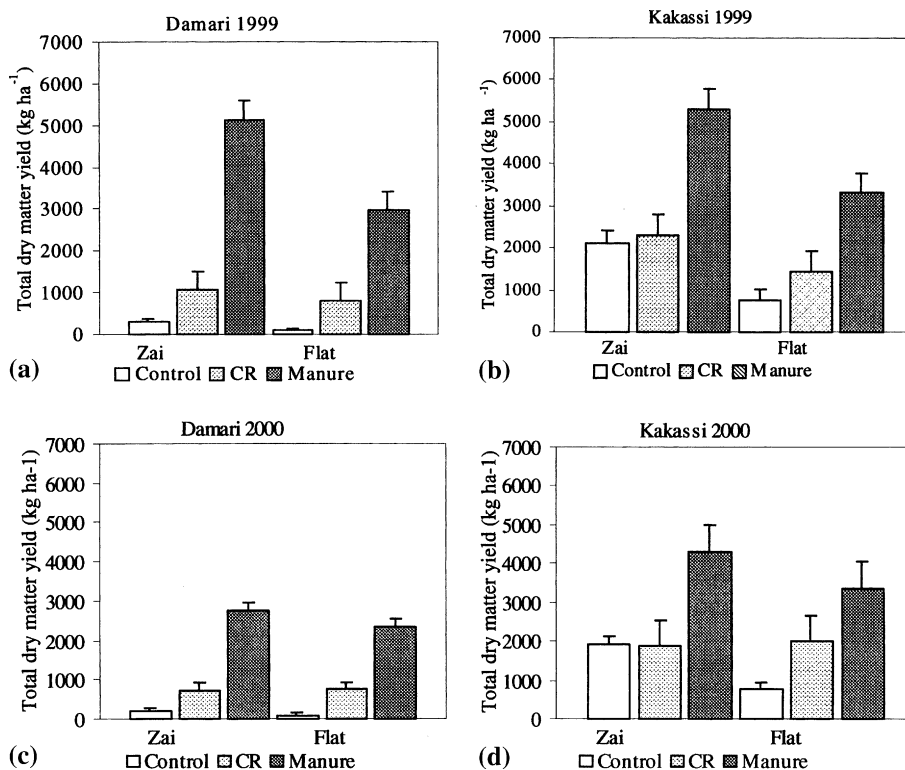

Figure 4. Millet total dry matter production as affected by sowing technique and amendment type. Damari and Kakassi, rainy seasons 1999 and 2000. CR, millet straw. Error bars are standard error of difference means.

straw (Figure 5); it was higher at higher rates of amendment application. The agronomic efficiency of manure was higher than that of millet straw (left side of Table 9) but the nutrient utilization efficiency of millet straw was higher than that of manure, particularly so for P and K (right side of Table 9). For both amendments, the higher the rate of application, the lower the agronomic efficiency (Table 10). These findings indicate that manure application increased nutrient uptake compared to millet straw, which was not efficiently used in the present study.

On-farm. At both sites in both years, a strong effect of amendment type on nutrient uptake was observed across years and sites (Figure 6). Nutrient uptake in the zai was higher than in flat planting although it was statistically significant only at Kakassi in 1999 and at Damari in 2000 (Figure 7b and c). Total rainfall was far below the long-term average at Kakassi in 1999 and at Damari in 2000 (Figure 1), which led to a strong effect of the zai on nutrient uptake, which was also

evident in the control plots at Kakassi (Figure 8). Therefore, the more favorable moisture conditions in the zai stimulated nutrient uptake and led to higher yields. No effect of planting technique and amendment type was observed on nutrient utilization efficiency except for Damari in 2000, where N utilization was more efficient under zai than under flat planting (55 vs. 51 kg kg⁻¹). Straw P and K were also more efficiently utilized than

Table 7. Effect of sowing technique on millet harvest index.

Sowing technique	Harvest index			
	1999		2000	
	Damari	Kakassi	Damari	Kakassi
Zai	0.19	0.17	0.25	0.21
Flat	0.18	0.16	0.20	0.12
Sed (\pm)	0.02	0.02	0.02	0.02
Fprob	>0.05	>0.05	0.015	0.003

Sed, standard error of difference between means. Damari and Kakassi, rainy seasons 1999 and 2000; values averaged over treatments.

Table 8. Chemical characteristics of the amendments used in the study.

Organic amendment	N (%)	P (%)	K (%)	C/N
	1999			
Millet straw	0.83	0.10	0.98	50
Manure	1.74	0.82	0.86	20
	2000			
Millet straw	1.18	0.10	1.57	50
Manure	2.53	0.94	1.72	21

manure P and K (553 vs. 337 kg kg⁻¹, sed = ± 34.2 and 178 vs. 165 kg kg⁻¹, sed = ± 2.9, respectively).

Zai increased grain yield produced per unit N (8 vs. 5 kg/kg, sed = ± 0.8) and K (10 vs. 6 kg kg⁻¹, sed = ± 1.1) compared to flat; so is the effect of cattle manure compared to millet straw (9.4 vs. 3.7 kg/kg, sed = ± 0.8 and 13.8 vs. 2.8 kg kg⁻¹, sed = ± 1.1), particularly at Damari in 2000.

The pooled data show that in general nutrient concentration and uptake in the grain were higher in 1999 than in 2000, but the nutrients were more

efficiently used in 2000 (Table 11) indicating that favorable rainfall distribution in 1999 favored nutrient uptake. Nitrogen, P and K concentration and uptake were higher at Kakassi than at Damari (Table 12), resulting in higher grain yield except for Damari in 1999. But grain yield per unit of nutrient absorbed was higher at Damari than at Kakassi, which could be due to the better rainfall conditions at Damari which improved nutrient utilization efficiency.

Rainfall use efficiency

Rainfall was more efficiently used in the zai than in flat planting, even though some site and year-specific trends were observed. At Damari in 1999 and at Kakassi in 2000 with relatively high total rainfall, the effect of planting technique on water use efficiency was not statistically significant (Table 13), whereas at Kakassi in 1999 and at Damari in 2000, seasons with lower total rainfall,

Table 9. Agronomic efficiency and nutrient utilization efficiency as affected by amendment type; Sadoré, dry season 1999 (kg kg⁻¹); values averaged over treatments.

Amendment	Agronomic efficiency			Nutrient utilization efficiency		
	N	P	K	N	P	K
Millet straw	11	92	9	38	785	25
Cattle manure	38	81	78	39	516	22
Sed (±)	2.7	6.6	5.4	0.7	37.2	0.7
Fprob	<0.001	>0.05	<0.001	>0.05	<0.001	<0.001
Flat non-amended				40	887	52
zai non-amended				37	731	26
Sed (±)				1.0	84.4	0.8
Fprob				0.08	>0.05	<0.001

Sed, standard error of difference between means.

Table 10. Agronomic efficiency and nutrient utilization efficiency as affected by amendment rate of application; Sadoré, dry season 1999 (kg kg⁻¹); values averaged over both amendments types.

Rates	Agronomic efficiency			Nutrient utilization		
	N	P	K	N	P	K
1 t ha ⁻¹	33	118	57	39	724	26
3 t ha ⁻¹	25	93	43	39	659	24
5 t ha ⁻¹	16	47	30	38	569	21
Sed (±)	3.3	8.0	6.6	0.9	45.5	0.9
Fprob	0.002	<0.001	0.008	>0.05	0.021	<0.001

Sed, standard error of difference between means.

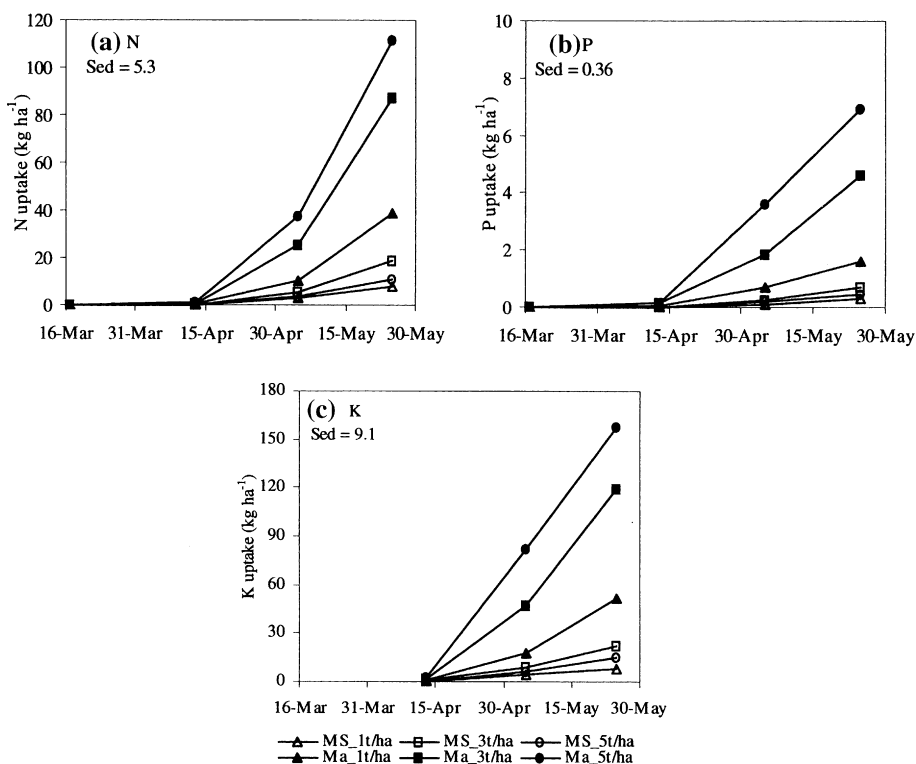

Figure 5. Millet nutrient uptake dynamics during growth; Sadoré 1999. (Crop allowed growing for 2 months and half). MS, millet straw; Ma, manure.

water use efficiency in zai was higher than in flat planting (1.9 vs. 1.1 kg/mm at Kakassi and 1.4 vs. 0.8 kg/mm at Damari). Therefore, the effectiveness of the technology is more evident under drier conditions. Water use efficiency was higher with manure application than with millet straw for both sites and years (Table 14).

Discussion

Grain yield and total dry matter production

Farmers of the Sahel hardly use any inorganic fertilizer. According to Bationo et al. (2003), farmers in the region apply less than 5 kg ha⁻¹ of plant nutrients, and subsidies on mineral fertilizers have been removed which has increased unsustainable nutrient mining. Therefore, the introduction of organic amendments is important to meet the crops' nutritional requirements and sustain soil fertility. These amendments are even more

important for resource-poor farmers who use them in combination with the zai technique. The organic amendments induced better plant growth and development, which resulted in relatively high TDM production. Grain and total dry matter yields with millet straw amended plots were lower than with cattle manure which is consistent with lower nutrient contents in the millet straw amendment, especially in terms of N and P. Bationo and Mukwenye (1991), Michels et al. (1995), Pichot et al. (1981) and Pieri (1986) have reported the beneficial effect of crop residues and cattle manure application on millet yield. The present results with cattle manure support this view, but the 815 kg ha⁻¹ total dry matter obtained with 3 t ha⁻¹ crop residue application was far below the 3673 kg ha⁻¹ reported by Buerkert et al. (2000) for Sadoré in Niger with 500 kg ha⁻¹ surface-applied crop residues. However, in the latter study the mulch may have reduced wind erosion, sand blasting and burial of seedlings (Michels et al. 1995). Furthermore, millet straw in the zai pit may

locally have increased N immobilization due to the high C/N ratio.

Increasing the rate of manure application from 3 to 5 t ha⁻¹ did not produce a proportional yield increase, which suggests that the lower rate is preferable from the farmer's viewpoint; however, further investigations are needed as this also depends on the rainfall. Grain yield was substantially higher in the non-amended zai at Kakassi than in the control (flat planting). Except for extractable P, soil fertility at Kakassi was much higher than at Damari; thus, the increased water availability in the zai pits at this site alleviated the primary constraint for crop production, water. However, in both years, the zai pits accumulated wind-blown sand and plant debris before planting, which may have constituted an additional nutrient source for the millet.

The combination of cattle manure application with zai always resulted in grain yield increases. This illustrates the combined effect of the readily available nutrients from the cattle manure and the water harvested in the zai pits.

Nutrient uptake, utilization and agronomic efficiency

Higher nutrient availability stimulated crop growth; but crop yield per unit of nutrient absorbed was lower under good nutritional conditions indicating that zai may be relatively less efficient on good soils. Also, nutrient utilization efficiency decreased with increased amendment rate of application. Therefore, to make better use of the limited quantity of available organic matter, it is necessary to identify suitable application rates for the zai system. According to Williams et al. (1995), farmers in Niger can apply manure only to 10–40% of their cultivated fields each year, if they rely on their household livestock. Using good quality compost may help to overcome part of this constraint.

Penning de Vries and Djiteye (1982) and Breman and De Wit (1983) suggested that nutrient availability, but not water availability was the most important limiting factor for agricultural

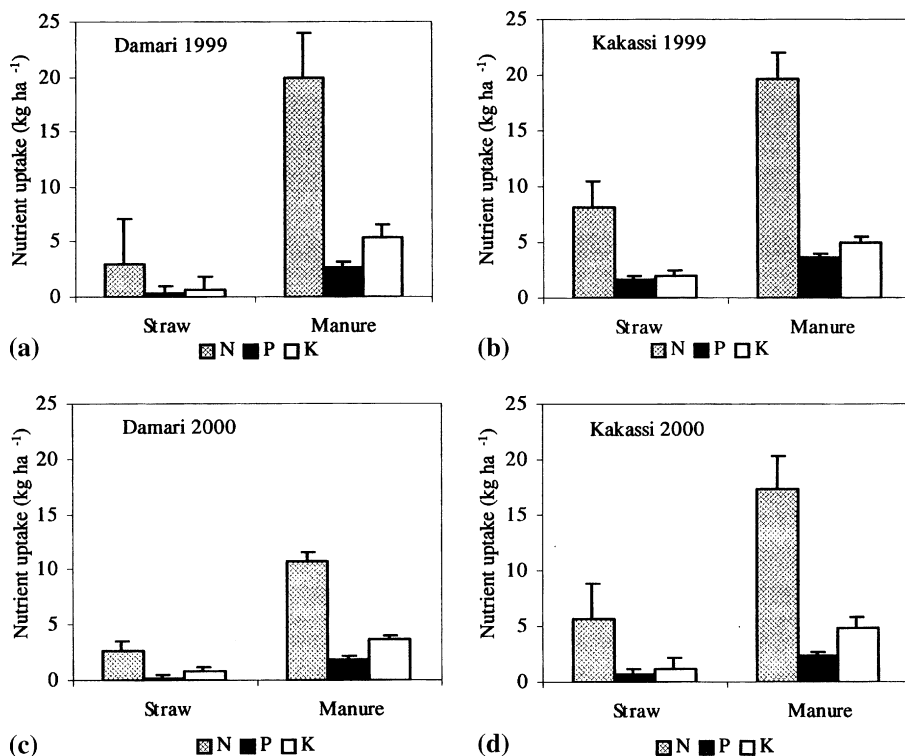

Figure 6. Millet nutrient uptake as affected by amendment type in 1999 and 2000 at Damari and Kakassi. Error bars are standard error of difference between means.

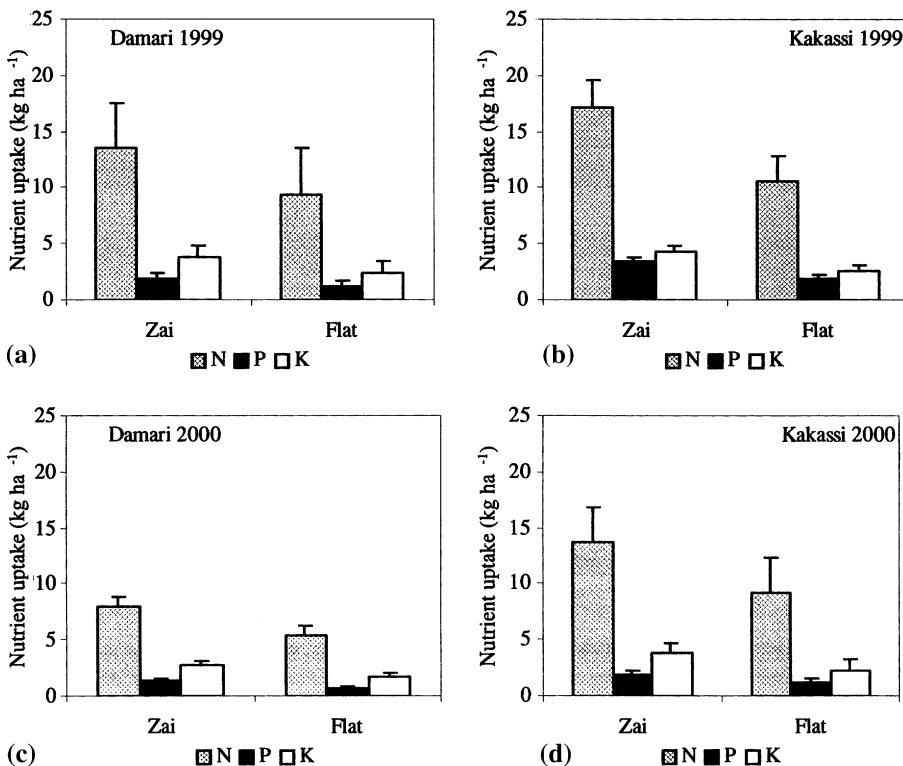

Figure 7. Millet nutrient uptake as affected by planting technique in 1999 and 2000 at Damari and Kakassi. Error bars are standard error of difference between means.

production in the Sahel. However, Bationo et al. (1990) reported a poor response of millet to N application in dry years, and Payne et al. (1995) argued that plant nutrients in agriculture in the Sahel should be considered in relation to the water component. Many studies have shown the strong interaction between the availability of water and

plant nutrients, and changing one of these factors can greatly affect the response to the other. Increased water supply not only directly enhances fertilizer response but also may affect indigenous nutrient availability and efficiency of utilization, Campbell et al. (1977), Campbell and Paul (1978), Wright and Black (1978) and Payne et al. (1995)

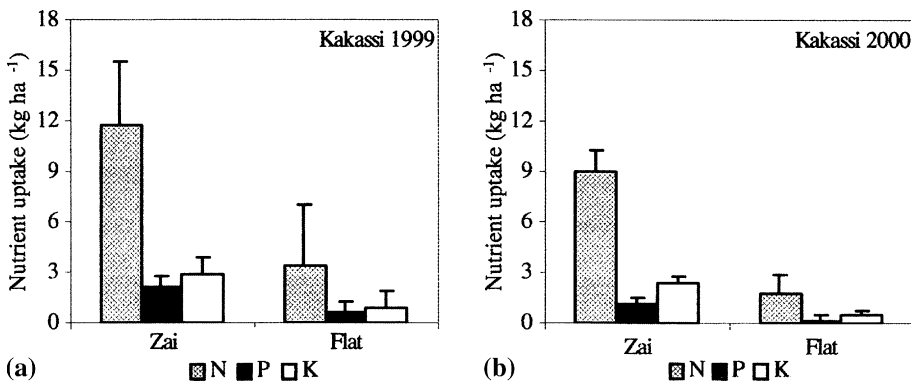

Figure 8. Millet nutrient uptake as affected by planting technique at Kakassi in control plots. Error bars are standard error of difference between means.

Table 11. Millet chemical characteristics in the two experimental years; values averaged over treatments and sites.

Year	% Nutrient in grain			Grain nutrient uptake (kg ha ⁻¹)			Nutrient utilization efficiency (kg kg ⁻¹)			Agronomic efficiency (kg kg ⁻¹)		
	N	P	K	N	P	K	N	P	K	N	P	K
1999	2.5	0.4	0.6	12.7	2.1	3.3	40	266	157	9	29	17
2000	2.5	0.3	0.6	9.1	1.3	2.6	48	395	182	5	22	7
Sed (±)	0.07	0.02	0.04	1.74	0.31	0.44	1.2	14.5	20.5	2.3	12.5	3.5
Fprob	<0.001	<0.001	>0.05	0.07	0.03	>0.05	<0.001	<0.001	>0.05	>0.05	>0.05	0.018

Sed, standard error of difference between means.

Table 12. Millet chemical characteristics in the two experimental sites; values averaged over treatments and years.

Site	% Nutrient in grain			Grain nutrient uptake (kg ha ⁻¹)			Nutrient utilization efficiency			Agronomic efficiency		
	N	P	K	N	P	K	N	P	K	N	P	K
Damari	2.1	0.3	0.6	9.1	1.3	2.7	48	389	167	10	39	16
Kakassi	2.5	0.4	0.6	12.7	2.1	3.3	41	273	171	5	12	9
Sed (±)	0.07	0.02	0.04	1.74	0.31	0.44	1.2	14.5	20.5	2.3	12.5	3.5
Fprob	0.001	0.001	>0.05	0.07	0.03	>0.05	<0.001	<0.001	>0.05	0.06	0.07	0.07

Sed, standard error of difference between means.

Table 13. Millet rain use efficiency as affected by planting technique in 1999 and 2000 at Damari and Kakassi; values averaged over all treatments.

Sowing technique	WUE – grain (kg mm ⁻¹)				WUE – dry matter (kg mm ⁻¹)			
	1999		2000		1999		2000	
	Damari	Kakassi	Damari	Kakassi	Damari	Kakassi	Damari	Kakassi
Zai	1.4	1.9	1.4	1.9	6.3	11.7	5.1	10.9
Flat	0.8	1.1	0.8	1.1	3.8	7.5	3.8	4.7
Sed	0.29	0.26	0.13	0.41	0.92	1.52	0.37	1.33
Fprob	>0.05	0.015	0.003	0.07	0.024	0.022	0.007	0.001

Sed, standard error of difference between means.

Table 14. Millet rain use efficiency as affected by amendment type in 1999 and 2000 at Damari and Kakassi; values averaged over all treatments.

Amendment	WUE – grain (kg mm ⁻¹)				WUE – dry matter (kg mm ⁻¹)			
	1999		2000		1999		2000	
	Damari	Kakassi	Damari	Kakassi	Damari	Kakassi	Damari	Kakassi
Millet straw	0.3	1.0	0.4	0.9	1.9	5.8	2.1	4.8
Manure	1.9	2.0	1.8	2.1	8.2	13.3	6.7	10.8
Sed	0.29	0.26	0.13	0.41	0.92	1.52	0.37	1.33
Fprob	<0.001	0.004	<0.001	0.02	<0.001	<0.001	<0.001	0.001

Sed, standard error of difference between means.

have reported that plants grown with adequate nutrient supply extend roots deeper than when grown in deficient conditions. Increased root proliferation increases the volume of soil colonized, thereby increasing the potential for water use and thus reducing the probability of plant growth being restricted by intermittent periods of drought (Brown, 1971). In the zai technique, water and nutrients are placed in the vicinity of plant roots. Therefore it favours crop growth and alleviates the adverse effects of the irregularly occurring dry spells. In addition, when cattle manure or other good quality amendments are used in the zai, they induce efficient water use compared to the traditional flat planting.

Conclusions

Zai is a strong tool to mitigate a major constraint to agricultural production in the Sahel, the limited total rainfall and its uneven distribution in time and space, because zai alleviates the effect of dry spells during plant growth, and improves rain use efficiency by a factor of two compared to traditional flat planting. This study confirms the results of former studies that substantial increases in TDM and grain yields are possible when using the zai technique. The effects are not only due to the water harvesting, but also due to the amendments, and they can be increased when using high-quality amendments. More than 1 t ha⁻¹ millet grain yield was obtained from zai amended with cattle manure at a rate of 3 t ha⁻¹. An additional 500 kg ha⁻¹ of grain were obtained by planting in zai compared to flat planting, an important gain to the farmers.

Zai and cattle manure application improved millet nutrient uptake, crop growth, and ultimately, yields. Economic yield per unit of nutrient applied under zai was higher than without zai.

Nevertheless, availability of good-quality organic amendments is a pre-requisite for the success of the technology on highly degraded soils such as at Damari. In this regard, the scarcity of animal dung presents a constraint to the use of the zai technology. However, farmers are generally able to prepare good quality compost using all kinds of domestic wastes, weeds, and leguminous residues before and during the onset of the rainy season (own observation), although there may be

limits to this (cf. de Ridder et al. 2004). Also, total dry matter gain increased by 115% when increasing the manure application rate from 1 to 3 t ha⁻¹, but only by 12% from a further increase to 5 t ha⁻¹. This (and also the significant reduction in nutrient agronomic efficiency) shows that an optimal application rate should be around 3 t ha⁻¹. Here, nevertheless, further work is needed to optimize the use of the limited available organic amendments.

References

- Amissah-Arthur A., Mougnot B. and Loireau M. 2000. Assessing farmland dynamics and land degradation on Sahelian landscapes using remotely sensed and socioeconomic data. *Intl J. Geograph. Inform. Sci.* 14(6): 583–599.
- Bationo A., Christianson C.B. and Baethgen W.E. 1990. Plant density and nitrogen fertilizer effects on pearl millet production in a sandy soil in Niger. *Agron. J.* 82: 290–295.
- Bationo A. and Mokwunye A.U. 1991. Role of cattle manures and crop residue in alleviating soil fertility constraints to crop production: with special reference to the Sahelian and the Soudanian zone of West Africa. *Fertil. Res.* 29: 117–125.
- Bationo A., Mokwunye U., Vlek P.L.G., Koala S. and Shapiro B.I. 2003. Soil fertility management for sustainable land use in the West African sudano-sahelian zone. In: *Soil Fertility Management in Africa: A regional perspective*. Academy Science Publisher & Tropical Soil Biology and Fertility, pp. 253–292.
- Breman H. and de Wit C.T. 1983. Rangeland productivity and exploitation in the Sahel. *Science* 221: 1341–1347.
- Brown P.L. 1971. Water use and soil water depletion by dryland winter wheat as affected by nitrogen fertilization. *Agron. J.* 63: 43–46.
- Buerkert A., Bationo A. and Dossa K. 2000. Mechanisms of residue mulch-induced cereal growth increases in West Africa. *Soil Sci. Soc. Amer. J.* 64: 346–358.
- Campbell C.A. and Paul B.A. 1978. Effect of fertilizer N and soil moisture on mineralization, N recovery and A-values, under spring wheat grown in small lysimeters. *Can. J. Soil Sci.* 58: 39–51.
- Campbell C.A., Davidson H.R. and Warder F.D. 1977. Effects of fertilizer N and soil water in yield, yield components, protein content and N accumulation in the aboveground parts of spring wheat. *Can. J. Soil Sci.* 57: 311–327.
- Casenave A. and Valentin C. 1989. Les états de surface de la zone sahélienne; Influence sur l'infiltration. Les processus et les facteurs de réorganisation superficielle, Ed. ORSTOM. Institut Français de Recherche Scientifique pour le Développement en Coopération, Collection Didactiques, Paris, pp. 65–190.
- Christianson C.B. and Vlek P.L.G. 1991. Alleviating soil fertility constraints to food production in west Africa: efficiency of nitrogen fertilizer applied to food crops. *Fertil. Res.* 29: 21–33.
- de Ridder N., Breman H., van Keulen H. and Stomph T.J. 2004. Revisiting a 'cure against land hunger': soil fertility

- management and farming systems dynamics in the west African Sahel. *Agricult. Sys.* 80: 109–131.
- Hassan A. 1996. Improved traditional planting pits in the Tahoua department, Niger. An example of rapid adoption by farmers. In: Reij C., Scoones I. and Toulmin C. (eds.), *Sustaining the Soil. Indigenous Soil and Water Conservation in Africa*. Earthscan Publisher, pp.56–61.
- Houba V.J.G., Van de Lee J.J. and Novozamsky I. 1995. Soil and Plant Analysis, Part 5B, Syllabus 1995. In: *Soil Analysis Procedures, Other Procedures*. Department of Soil Science and Plant Nutrition, Wageningen Agricultural University.
- Kaboré V. 1995. Amélioration de la production végétale des sols dégradés (zipelles) du Burkina Faso par la technique des poquets (“zai”). Ph.D. thesis, EPFL (no 1302), Lausanne, 201 pp.
- Katyal J.C. and Vlek P.L.G. 2000. Desertification – concept, causes and amelioration, ZEF Discussion Paper on Development Policy 33, 65 pp.
- Lawes Agricultural Trust 2000. GENSTAT® 6 release 1. VSN International, Wilkinson House, Jordan Hills Road, Oxford, UK.
- Michels K., Sivakumar M.V.K. and Allison B.E. 1995. Wind Erosion Control using Crop Residue: I. Effect on soil flux and soil properties. *Field Crop. Res.* 40: 101–110.
- Oldeman L.R., Hakkeling R.T.A. and Sombroek W.G. 1990. *World Map of the Status of Human-Induced Soil Degradation: An Explanatory Note*, Revised edition. International Soil Reference and Information Centre, United Nation Environment Program, Wageningen, Nairobi.
- Ouedraogo M. and Kaboré V. 1996. The “zai”: a traditional technique for the rehabilitation of degraded land in the Yatenga, Burkina Faso. In: Reij C., Scoones I. and Toulmin C. (eds.), *Sustaining the Soil. Indigenous Soil and Water Conservation in Africa*. Earthscan Publisher, pp.80–92.
- Payne W.A., Lloyd R., Arthur H., Onken B. and Wendt C.W. 1995. Nitrogen and phosphorus uptake in pearl millet and its relation to nutrient and transpiration efficiency. *Agron. J.* 87: 425–431.
- Penning de Vries F.W.T. and Djiteye M.A. 1982. L'élevage et l'exploitation des pâturages au Sahel. In: Penning de Vries F.W.T. and Djiteye M.A. (eds.), *La productivité des pâturages Sahéliens. Une étude des sols, des végétations et de l'exploitation de cette ressource naturelle*. Centre for Agricultural Publication and Documentation, Wageningen, The Netherlands.
- Pichot J., Sedogo M.P., Poulain J.L. and Arrivets J. 1981. Evolution de la fertilité d'un sol ferrugineux sous l'influence de fumures minérales et organiques. *Agron. Trop.* 36: 122–133.
- Pieri C. 1986. Fertilisation des cultures vivrières et fertilité des sols en agriculture paysanne sub-saharienne. *Agron. Trop.* 41: 1–20.
- Roose E., Dugué P. and Rodriguez L. 1992. La G.C.E.S. Une nouvelle stratégie de lutte anti-érosive appliquée à l'aménagement de terroirs en zone soudano-sahélienne du Burkina Faso. *Revue Bois et Forêts des Tropiques* 233: 49–62.
- Roose E., Kaboré V. and Guenat C. 1993. Le “zai”: Fonctionnement, limites et amélioration, d'une pratique traditionnelle africaine de réhabilitation de la végétation et de la productivité des terres dégradées en région soudano-sahélienne (Burkina Faso). *Cahier de l'ORSTOM, Série Pédologie* XXVIII(2): 59–173.
- Soil Survey Staff 1998. *Keys to Soil Taxonomy*, 8th edition. USDA/NRCS.
- Sundquist B. 2004. Land area data and aquatic area data; a compilation. Edition 1, March, 2004. <http://home.Alltel.net/bsundquist/laO.html> [checked 5.12.2005].
- West L.T., Wilding L.P., Landeck J.K. and Galhoun F.G. 1984. Soil Survey of the ICRISAT Sahelian Center, Niger. Soil and Crop Science Department/TropSoils Texas A&M System, College Station, Texas in cooperation with the International Crop Research Institute for the Semi-Arid Tropics.
- Williams T.O., Powell J.M. and Fernandez-Rivera S. 1995. Manure availability in relation to sustainable food crop production in Semi-Arid West Africa: evidence from Niger. *Quart. J. Intl. Agricul.* 34: 248–258.
- Wright J.R. and Black A.L. 1978. Soil water use and recharge in a fertilized mixed prairie plant community. *J. Range Manag.* 31: 280–282.

Short-term effects of cover crops on stem borers and maize yield in the humid forest of southern Cameroon

Chabi-Olaye A.^{1,2}, Nolte C.², Schulthess F.³ and Borgemeister C.^{1*}

¹ Institute of Plant Diseases and Plant Protection, Herrenhäuser Str. 2, 30419, Hannover, Germany; ² International Institute of Tropical Agriculture, Humid Forest Ecoregional Centre, (IITA/HFC), Messa 2008 Yaoundé, Cameroon;

³ International Center of Insect Physiology and Ecology, P.O. Box 30772-00100, Nairobi, Kenya; * Author for correspondence (phone +49-511-7622642; fax +4-511-7623015; email: borgemeister@ipp.uni-hannover.de)

Abstract

Field trials were designed to investigate the effect of leguminous cover crops and bush fallow on maize yield and stem borer attacks with particular reference to *Busseola fusca* (Fuller) (Lep.: Noctuidae). Maize alternate cropping was compared with a mucuna-maize, cajanus-maize and bush fallow-maize cropping sequences. Total N content in the 0–10 cm layers of the soil was 26.0–29.2% higher after mucuna and cajanus fallows than after continuous maize production. Total N in plant dry matter increased with the availability of N in the soil and was significantly positively correlated with the plant height. Borer-days were 40–46% higher after mucuna and cajanus fallows than after maize continuous cropping whereas larval mortality at 63 days after planting (DAP) was 1.5–2.0 times higher in both leguminous fallows than in the continuous maize systems. As results, the percent of stem tunnelled did not vary significantly among treatments. The average yield loss due to borers was five times higher in the maize-maize sequence as compared to both cover crop-maize sequences, when comparing between control and insecticide-treated plants, suggesting that increased nutritional status of the plant enhanced both borer fitness and plant vigour but with a net-benefit for the plant.

Key words: Cover crop, Nitrogen, Maize stems borers, Yield loss

Introduction

Maize is one of the most important sources for carbohydrates in sub-Saharan Africa (FAO, 2001). In Cameroon, maize is grown across all agro-ecological zones from sea level to the highlands at 2,000 m. The major constraints for maize production in the forest zone of Cameroon are *inter alia* weeds, pests, the most important include lepidopterous stem borers (such as the noctuids *Busseola fusca* (Fuller) and *Sesamia calamistis* Hampson and the pyralids *Eldana saccharina* (Walker) and *Mussidia nigrivenella* Ragonot) and termites, grasscutters, and birds, and low soil fertility (Hauser and Nolte 2002; Hauser *et al.*, 2002). These constraints lead to a reduction in quality and quantity of pre- and post-harvest maize (Cardwell

et al., 1997; Schulthess *et al.*, 1997; Ndemah, *et al.*, 2001).

During the last two decades field experiments in sub-Saharan Africa showed that crop rotation of maize with several leguminous cover crops improved soil fertility properties and considerably increased succeeding maize yields (Carsky *et al.*, 1998, 2001; Hauser and Nolte, 2002). However, no studies have addressed how lepidopteran stem borers are affected by these cropping systems. Thus, field trials were set up to investigate densities of stem borers in different maize-legume cropping sequences and their effects on plant growth and yield of maize. In the present study, emphasis was given to *B. fusca*, which is the economically most important maize pest in the region (Cardwell *et al.*, 1997; Ndemah *et al.*, 2001).

Materials and methods

Experimental procedure and sampling

Experiments were conducted at Nkometou (4° 05'N, 11° 33'E), a village 40 km west of Yaoundé, Cameroon. The site is characterized by a bimodal distribution of rainfall, the first and second growing seasons (hereafter referred to as long and short rainy seasons, respectively). The chemical analyses of the top soil (0–20 cm) revealed a pH (H₂O) of 5.6, 0.14% total N, 2.15% organic carbon, 11.4 µg g⁻¹ available P (Mehlich-III extract) (Mehlich, 1984), and 0.23 cmol (+) 100 g⁻¹ of exchangeable K.

Two field trials were set up. The first, during the long-short rainy season sequence (LSR) where cover crops preceded maize during the long rains, and the second during the short-long season sequence (SLR), in which leguminous cover crops were planted during the short and maize in the long rains of the next year. The cover crop species used were *Mucuna pruriens* var. *Jaspeada* and *Cajanus cajan* (L.) Millsp. (local var.) (both Fabaceae). Each rotation treatment included a control and insecticide treatment of the subsequent

maize crop. The treatments were arranged in a completely randomised block design with four replications. Plots were 6 by 6 m each. *Mucuna* was planted at 25 by 50 cm distance (8 grains m⁻²), *cajanus* at 50 by 50 cm (8 plants m⁻²) and maize at 40,000 plants ha⁻¹).

Twelve plants per plot were destructively sampled every two weeks. Data recorded in insecticide-free plots were plant height, the number of borers and an estimate of borer tunnel length. At harvest, the grain yield was recorded for each plot.

For plant nutrient analysis, four plants were randomly taken from each plot. All fresh biomass samples were oven-dried at 65°C to constant weight and the corresponding N concentration determined. In addition, soil sampling was done prior to planting the succeeding maize.

Statistical analyses

Borer-days (i.e., the mean number of borers observed on consecutive sampling dates multiplied by the days between samples, and then summed over the whole sampling period) was used to assess the effect of borers

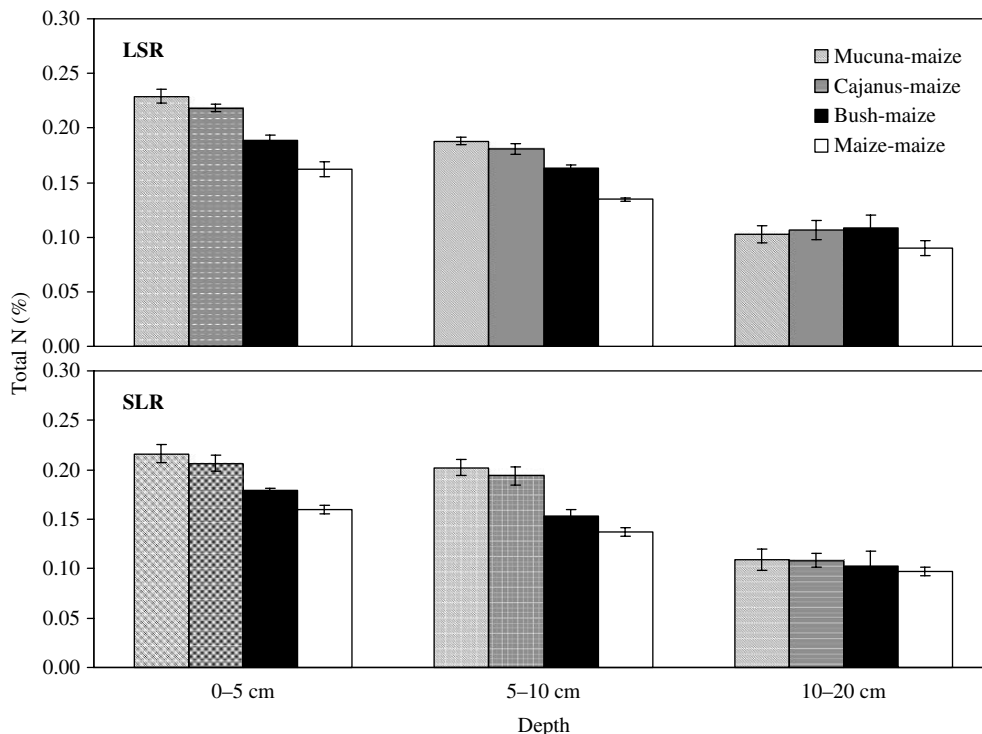

Figure 1. Total N content in the 0–5, 5–10 and 10–20 cm layers after natural regrowth and cover crop fallows, during the long-short rainy (LSR) and short-long rainy (SLR) season sequence.

on plant. Cumulative borer-days up to 63 DAP, larval mortalities, percentage of stem tunnelled and grain yield were subjected to analysis of variance (ANOVA), using the general linear model (GLM) procedure of SAS (SAS, 1997). Means were separated using the t-test ($P = 0.05$). For the yield variable the *LSD* values at 5% significant level were computed. Regression analyses were used to describe the relationship between the total N (%) in the plant dry matter and plant growth as well as borers density per plot.

Results

Relationship between N, plant growth, borers and their damage

Total N content in the soil decreased significantly with depth and was higher after mucuna and cajanus fallows than after the continuous maize production system ($P < 0.001$) in the 0–10 cm layer. It was also higher after both leguminous fallows than after natural fallow ($P < 0.001$) within the same layer (Figure 1).

The plant height was significantly affected by the total N in the stem dry matter at 63 DAP ($P < 0.05$). Hence, increasing the total N uptake increased plant height as indicated by the strong relationship between plant height and total N in the stem dry matter ($r^2 = 0.68$, $n = 64$, $P < 0.001$). The average plant height (\pm *s.e.*) at 63 DAP was 100.6 ± 5.2 in maize after maize; 110.0 ± 4.2 in maize after natural fallow; 118.5 ± 5.2 in maize after cajanus and 128.8 ± 3.9 cm in maize after mucuna fallow. Similarly, borer densities increased with total N in the plant dry matter (Figure 2). However, the relationship between larval density and percent N in plant dry matter was stronger at 35 DAP than at 63 DAP ($r^2 = 0.53$ and 0.24 , respectively, $P < 0.001$).

In both seasonal sequences (LSR and SLR), borer-days varied significantly with cropping sequences

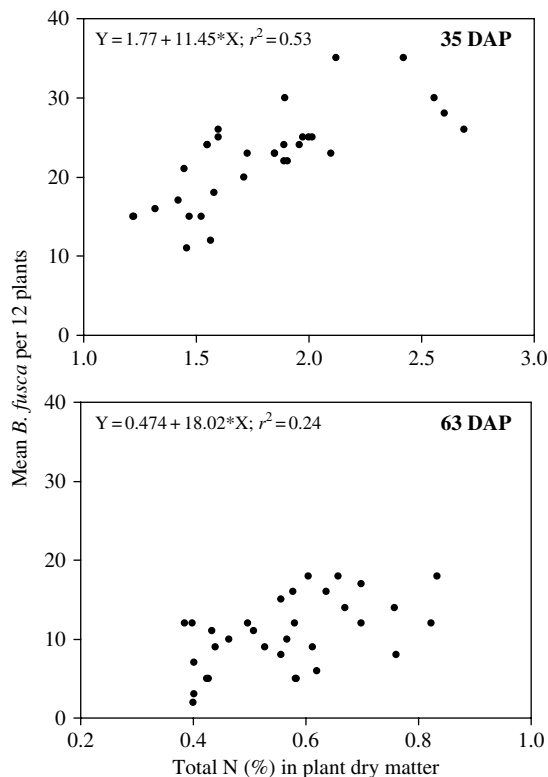

Figure 2. Relationship between average *B. fusca* density per plot and total N (%) in leaf and stem dry matter at 35 and 63 days after planting (DAP) respectively.

($P < 0.001$) (Table 1). They were 40–46% higher after mucuna and cajanus fallows than after sequential maize production, and 21.3–26.8% higher after both leguminous fallows than after natural fallow (Table 1).

Larval mortalities at 63 DAP were 1.5–2.0 times higher in both leguminous fallows than in the continuous maize system and 1.2–1.4 times higher after natural fallow than in the maize-maize treatment (Table 1).

Table 1. Mean borer-days, larval mortality (%) and percent stem tunnelled at 63 DAP.

Treatments	Seasonal sequence					
	LSR			SLR		
	Borer-days	Mortality	Tunnel	Borer-days	Mortality	Tunnel
Maize-maize	36.0c	45.9c	3.2	46.2c	30.4c	10.9
Bush-maize	47.2b	58.6b	3.3	62.5b	42.4b	7.5
Cajanus-maize	60.8a	69.2a	3.5	81.7a	58.5a	8.6
Mucuna-maize	59.2a	70.3a	4.0	89.1a	63.3a	7.4
<i>s.e.</i>	1.92	3.33	1.16	3.26	3.98	2.75
<i>d.f.</i>	12	12	12	12	12	12

Table 2. Effect of different fallow systems on maize grain yield (Mg ha^{-1}).

Treatments	Seasonal sequence			
	LSR		SLR	
	Infested Plot	Insecticide-treated plot	Infested Plot	Insecticide-treated plot
Maize-maize	1.74	2.19	2.18	2.84
Bush-maize	2.66	2.88	3.54	4.02
Cajanus-maize	2.99	3.14	4.33	4.50
Mucuna-maize	3.41	3.56	4.82	4.94
<i>P</i>	<0.001		<0.001	
<i>lsd</i> (5 %)	0.40		0.55	

The mean percentage of stems tunnelled did not vary significantly between the LSR and SLR treatments (Table 1).

Short-term effects of cover crops on maize grain yield

Significant differences in grain yield were obtained between the maize-maize and fallow system treatments. They were between 31.4–42.4% in the LSR, and 36.7–48.5% in the SLR (Table 2). Hence, the yield loss of maize grains due to insects was five times higher in the maize-maize sequence as compared to both cover crop-maize sequences (Figure 3A and B).

Discussion

In the fallow systems, significantly higher stem borer densities were recorded than in continuous maize cropping during the early part of plant growth, when >95% of the borer larvae collected were found feeding in the whorl. This suggests that larval arrestment was higher or mortality was lower on plants with high N contents, and is corroborated by the strong relationship between N in the leave dry matter and densities of *B. fusca* ($r^2 = 0.53$). With increase of plant age, the r^2 values considerably decreased and larval mortality at 63 DAP was significantly higher in the fallow

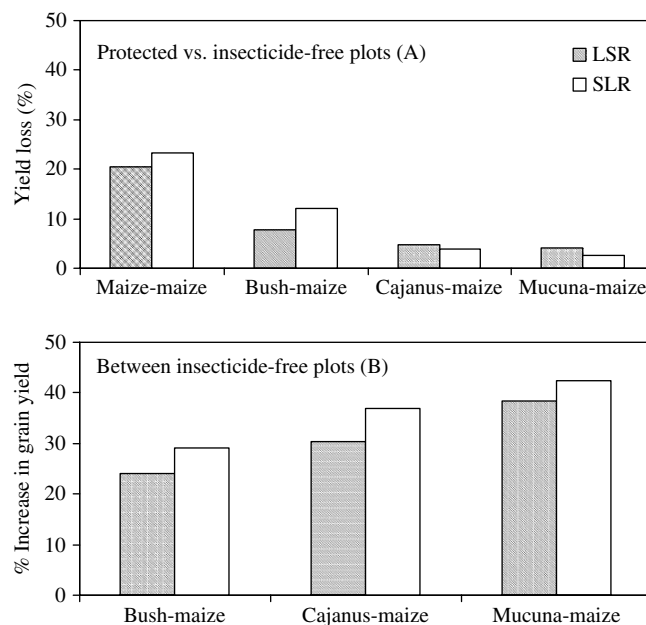

Figure 3. Effect of cover crops on grain yield losses due to insects (A) and increase in yield due to the fallows (B).

system compared to the continuous maize cropping. Yet, the percentage stem damage, that is, the economically most important damage variable (Bosque-Pérez and Mareck, 1991; Schulthess *et al.*, 1997) did not vary significantly among treatments.

It is well known that the N content of plants can be a crucial factor for the development and reproduction of herbivores (Strong *et al.*, 1984). Saroja *et al.* (1987) reported that every increase in N level resulted in an increase in incidence of both pests (e.g. *Scirpophaga incertulas* Walker (Lepidoptera, Pyralidae, Schoenobiinae)) as well as an increase in yield. In the present study, borer populations in cropping sequences were higher than in continuously cropped maize, but the borer-induced grain yield losses were considerably lower. These results confirm previous findings by Sétamou *et al.* (1995) who hypothesised that an increased nutritional status of the plants enhanced both borer fitness and plant vigour but with a net benefit for the plants.

Our results clearly show that leguminous fallow systems appear to be the better management practice than a continuous maize production system, with more or less similar effects on borers as insecticide applications. Presently, we are investigating the direct effects of N and K on the bionomics of *B. fusca* and damage caused to maize in the field.

Acknowledgement

This study was financed by a grant from the German Research Council (DFG).

References

- Bosque-Pérez N.A. and Mareck J.H. 1991. Effect of the stem borer *Eldana saccharina* Walker (Lepidoptera: Pyralidae) on the yield of maize. *Bulletin of Entomological Research* 81: 243–247.
- Cardwell K., Schulthess F., Ndemah R. and Ngoko Z. 1997. A systems approach to assess crop health and maize yield losses due to pests and diseases in Cameroon. *Agriculture, Ecosystems and Environment* 65: 33–47.
- Carsky R.J., Becker M. and Hauser S. 2001. Mucuna cover crop fallow systems: Potentials and limitations, pp. 111–136. In: Tian G., *et al.*, eds. Sustaining Soil Fertility in West Africa. SSSA Special Publications 58. *Soil Science Society of America, Inc./American Society of Agronomy, Inc.*, Madison, WI, USA.
- Carsky R.J., Tarawali S.A., Becker M., Chikoye D., Tian G. and Sangiga N. 1998. *Mucuna-herbaceous cover legume with potential for multiple uses*. 52 pp. Resource and Crop Management Research Monograph Vol. 25, International Institute of Tropical Agriculture, Ibadan, Nigeria.
- FAO 2001. FAOSTAT Data Query Crops, www.apps.fao.org.
- Hauser S. and Nolte C. 2002. Biomass production and N fixation of five *Mucuna pruriens* varieties and their effect on maize yields in the forest zone of Cameroon. *Journal of Plant Nutrition and Soil Science* 165: 101–109.
- Hauser S., Henrot J. and Hauser A. 2002. Maize yields in mulched and burned *Mucuna pruriens* var. utilis and *Pueraria phaseoloides* relay fallow systems in southern Cameroon. *Biological Agriculture and Horticulture* 20: 243–256.
- Mehlich M. 1984. Mehlich 3 soil test extractant: a modification of the Mehlich 2 extractant. *Communications in Soil Science and Plant Analysis* 15: 1409–1416.
- Ndemah R., Schulthess F., Korie S., Borgemeister C. and Cardwell K.F. 2001. Distribution, relative importance and effect of lepidopterous borers on maize yields in the forest zone and mid-altitude of Cameroon. *Journal of Economic Entomology* 94: 1434–1444.
- Saroja R., Jagannathan R. and Raju N. 1987. Effect of N nutrition and rice variety on leaffolder (LF), yellow stem borer (YSB), and grain yield. *International Rice Research Newsletter* 12: 11–12.
- SAS Institute 1997. SAS/STAT Software: Changes and Enhancements, Through Release 6.12. SAS Institute, North Carolina.
- Schulthess F., Bosque-Pérez N.A., Chabi-Olaye A., Gounou S., Ndemah R. and Goergen G. 1997. Exchanging natural enemies species of lepidopterous cereal stemborers between African regions. *Insect Science and its Application* 17: 97–108.
- Sétamou M., Schulthess F., Bosque-Pérez N.A. and Thomas-Odjo A. 1995. The effect of stem and cob borers on maize subjected to different nitrogen treatments. *Entomologia Experimentalis et Applicata* 77: 205–210.
- Strong D.R., Lawton J.H. and Southwood T.R.E. 1984. Insects on plants. *Community patterns and mechanisms*. Blackwell Scientific Publications. Oxford.

Improving cereal productivity and farmers' income using a strategic application of fertilizers in West Africa

Ramadjita Tabo^{1*}, Andre Bationo², Bruno Gerard¹: Jupiter Ndjeunga¹, Daniel Marchal³, Bassirou Amadou³, Mallam Garba Annou⁴, Diakala Sogodogo⁵, Jean-Baptiste Sibiry Taonda⁶, Ousmane Hassane¹, Maimouna K. Diallo¹ and Saidou Koala¹

¹International Crops Research Institute for the Semi-Arid Tropics (ICRISAT), B.P. 12404, Niamey, Niger; ²Tropical Soil Biology and Fertility (TSBF-CIAT), Nairobi, Kenya; ³FAO Projet Intrants, Niamey, Niger; ⁴Institut National de la Recherche Agronomique du Niger (INRAN), Niamey, Niger; ⁵Institut d' Economie Rurale (IER), Cinzana, Mali; ⁶Institut de l'Environnement et de Recherches Agricoles (INERA), Saria, Burkina Faso; *Corresponding author: ICRISAT, B.P. 12404, Niamey, Niger; Tel: +227-722626/722529; Fax: +227-734329; Email: r.tabo@cgiar.org

Abstract

In the past two years, ICRISAT, in collaboration with other International Agricultural Research Centres, National Agricultural Research and Extension Systems, has been evaluating and promoting point or hill application of fertilizer along with “Warrantage” in three West African countries, namely, Burkina Faso, Mali and Niger. The hill application of fertilizers consists of applying small doses of fertilizer in the planting hills of millet and sorghum. The combination of strategic hill application of fertilizer with complementary institutional and market linkages, through an inventory credit system (known as “Warrantage”) offers a good opportunity to improve crop productivity and farmers' incomes. Results from the two year on-farm trials showed that, on average, in all the three countries, grain yields of millet and sorghum were greater by 44 to 120% while incomes of farmers increased by 52 to 134% when using hill application of fertilizer than with the earlier recommended fertilizer broadcasting methods and farmers' practice. Substantial net profits were obtained by farmers using “Warrantage”. Farmers' access to credit and inputs was improved substantially through the “Warrantage” system. The technology has reached up to 12650 farm households in the three countries and efforts are in progress to further scale-up and out the technology to wider geographical areas.

Key words: Collaboration, millet, sorghum, poor soil fertility, strategic application of fertilizers, “Warrantage”/inventory credit system, net profits

Introduction

The Semi-Arid Sudano–Sahelan zone of West Africa remains one of the poorest regions of the world due to several constraints to agricultural development. The major constraints to arable agriculture are crop growth on the predominantly sandy soils that are of poor soil fertility; particularly in phosphorus (P) and nitrogen (N) (Bationo et al., 1992; 1993; 1998a;b); It has, however, been reported that phosphorus tends to be more limiting to crop productivity than nitrogen. Crop

response to nitrogen was found to be minimal until crop phosphorous requirements had been satisfied (Traore, 1974).

The little arable land in these zones is being gradually reduced due to the southward creep of the 400 mm isohyet (Sivakumar, 1992). Furthermore, due to the high population growth rate (3.4% per annum) and the increasing population density, considerable pressure is being put on the available cultivated lands. As a consequence of this, the length of fallow periods has significantly decreased and in most cases fallow

periods have completely disappeared; this has forced farmers to cultivate marginal and degraded lands, which result in low yields and further land degradation. Stoorvogel and Smaling (1990) reported that because of these problems, increases in crop production have resulted more from the expansion of cultivated areas than from improved productivity.

Van Keulen and Breman (1990, pp. 177–197) and Breman (1990, pp. 124–134) stated that the only real cure against land hunger in the West African Sahel lay in increased productivity of the arable land through the use of external inputs, mainly chemical fertilizers. Although soil fertility enhancement technologies have been developed over the years for the main staple food crops in West Africa, such as sorghum and millet, these technologies have not been adopted by farmers due to the high costs and unavailability of the inputs as well as the inappropriateness of the fertilizer recommendations made. Yields per hectare (ha) of sorghum and millet have therefore continued to decrease.

In the past years, a collaborative research effort between various national and international research institutions operating in the Sahel, led to the development of an effective technique to increase fertilizer use efficiency, reduce investment costs for resource-poor small scale farmers, thereby increasing crop growth and productivity (Bationo et al., 1998a;b; Buerkert and Hiernaux, 1998). The strategic application of fertilizer, also known as fertilizer “micro-dosing”, is based on applying small doses of fertilizer in the hill of the target grain crop.

Linking farmers to input or product markets, and the vertical integration between these are also becoming prerequisites to uptake of agricultural technologies. Efforts to develop institutional arrangements likely to improve the linkages of rural households to major markets are often major development challenges. The combination of the strategic application of fertilizer (fertilizer “micro-dosing”) with the complementary institutional and market linkages, through an inventory credit system (known as “Warrantage”) appears to be a promising strategy for improving crop productivity and increasing farmers' incomes in the Semi-Arid Sudano-Sahelian zone of West Africa. The “Warrantage” credit facility was initiated in Niger in the late 1990s to remove barriers to the adoption of soil fertility restoration inputs. Through this system, farmers have access to cash credit to enable them purchase external inputs such as fertilizers, and can store their surplus harvested grains to take advantage of the higher prices

offered during the period when market supply of grains begins to decline.

Through a United States Agency for International Development (USAID) grant, ICRISAT in collaboration with its national and international research and development partners have extended the fertilizer “micro-dosing” technology and “Warrantage” system to three countries in West Africa, namely, Burkina Faso, Mali and Niger. This paper highlights the major results obtained from the evaluation of these technologies in the three selected countries.

Materials and methods

Demonstrations/On-farm field trials

Demonstrations and field tests of the strategic application of fertilizers (fertilizer “micro-dosing”) were established in farmers' fields in the three participating countries in West Africa, namely Burkina Faso, Mali and Niger, during the 2002 and 2003 rainy seasons. The demonstration tests consisted of three plots per farmer, each plot measuring approximately 300 square metres (m²). Three treatments were applied comprising of the farmers' practice, the earlier recommended broadcasting system of fertilizer application (about 100 kg NPK (15:15:15) per ha, and the fertilizer “micro-dosing” at 4–6 grams per hill of compound fertilizer (NPK) [40 to 60 kg NPK per ha) or two grams of Diammonium Phosphate (DAP) per hill (20 kg DAP per ha)]. The test crops used were millet and sorghum. Plant densities under farmer conditions varied between 5,000 and 6,000 hills per ha while the recommended densities in the “micro-dosing” plots are about 10,000 hills per ha.

These demonstrations were managed by the farmers themselves together with technical backstopping from the resident extension workers. Farmers planted when they felt the soil was moist enough for germination of seeds. They used their own densities in the control plots, but had to follow the recommended densities in the ‘micro-dosing’ plots. They also weeded when it is time to do, in some cases, on the advice of field technicians. Harvesting is done by farmers under the supervision of field technicians. Data collection was done by the field extension agents and Non-Governmental Organization (NGO) staff. Regular visits and monitoring tours were undertaken by all the partners including ICRISAT, and other International Agricultural Research Centres (IARCs) and National Agricultural Research Centres (NARES) staff.

In addition to the field demonstrations, a socio-economic evaluation was carried out in order to assess the economic performance of the fertilizer “micro-dosing” technology. Net gain was calculated as the difference between the total revenues from the grain and the total cost of the main input, in this case the cost of fertilizer, as:

$$NG = R - C$$

Where, NG = Net gain; R = revenue from grains; and C = cost of fertilizer

Net gain was expressed in FCFA per ha. The cost of labour was not used as the data were collected from plots that are not large enough and the data were not reliable.

Burkina Faso

In Burkina Faso, INERA (Institut National de l'Environnement et de Recherches Agronomiques) coordinated the local project activities. Its NGO partners were: FNGN (Fédération Nationale des Groupements NAAM); ADRK (Association pour le Développement de la Région de Kaya); and Hunger Project.

FNGN operates in the northern zone of Burkina Faso. In the first year, demonstration plots were established in the three villages of Kain, Oula and Pobe Mengao. Ten farmers per village participated in the trials giving a total of 30 farmers in the northern zone. ADRK covered the Central North Zone. The demonstration fields were sited in the villages of Tallé, Nionko and Kassirin in the department of Pissila. There were ten farmers per village. Field trials were established by Hunger Project in the villages of Malgretenga, Sarago and Nagrengo. Ten farmers per village also participated in these demonstrations. The total number of villages and farmers involved in the demonstrations in Burkina Faso increased from 9 villages in 2002 to 30 villages in 2003 and from 90 farmers in 2002 to 210 farmers in 2003.

Mali

Three NGO partners: Winrock International, Sasakawa Global 2000 (SG 2000), and ADAF-Gallé; the Institut d' Economie Rurale (IER), the Malian National Research Institute that coordinates the local project in Mali were involved in the demonstration trials.

Demonstration plots were also set up during the 2002 and 2003 cropping seasons. In 2002, rainfall was below the long term annual average and there were also dry spells immediately following sowing and at the flowering stage, which adversely affected crop growth. In contrast, rainfall amount and distribution were adequate during the 2003 cropping season.

Demonstration plots of fertilizer micro-dosing were established in villages in the Mopti and in the Segou regions, which are covered by Winrock International. SG 2000 established the demonstration fields in villages in the Koulikoro and the Segou regions. Two zones were covered by ADAF-Gallé: The Mande and the Bélé Dougou zones. Sasakawa 2000 (SG 2000) conducted the demonstrations in Segou and Beledougou. Overall, 22 villages were involved in the field tests in 2002 and this increased to 44 villages in 2003. The number of participating farmers increased from 108 in 2002 to 321 in 2003

Niger

About 1,536 demonstrations were established by Projet Intrants of FAO in 254 villages in five departments in southern Niger, namely, Tillabery, Dosso, Tahoua, Maradi and Zinder. Projet Intrants of FAO collaborates with various structures including farmers' organizations, NGOs, projects and federations. The USAID TARGET project complemented the on-going work on fertilizer “micro-dosing” by expanding the work to more villages, increasing the frequency of joint visits to the demonstration fields by the Niger NARES, INRAN, Projet Intrants of FAO and ICRISAT, and, by enabling the project team to collect additional data which will be very useful for up-scaling the fertilizer “micro-dosing” technology. Sowing was done early in June 2002, but drought in June and July 2002 adversely affected crop establishment. Several farmers had to re-sow their fields. As the rains became more regular in August and September 2002, crop performance improved. In 2003, the rainfall conditions were good.

Training

Field agents and farmers

Before the start of the cropping seasons targeted for the 2002 and 2003 rainy seasons, extension agents and farmers in all the three selected West African countries

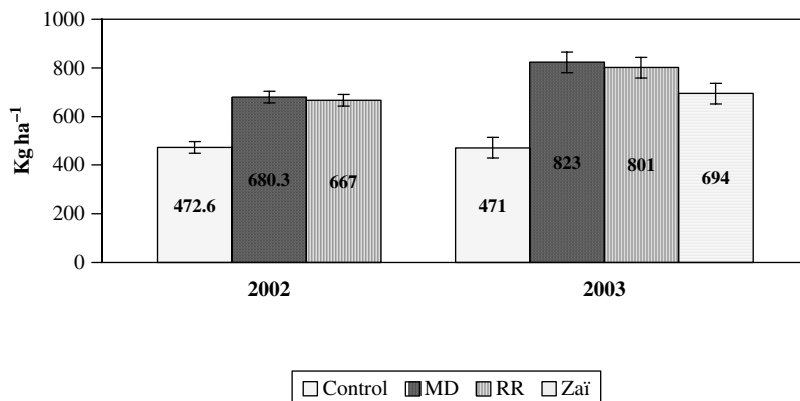

Figure 1. Millet Grain Yields (kg ha^{-1}) for Demonstration Trials (Control, Micro-Dose, Recommended Rates (RR), and Zai) in Burkina Faso, 2002 and 2003.

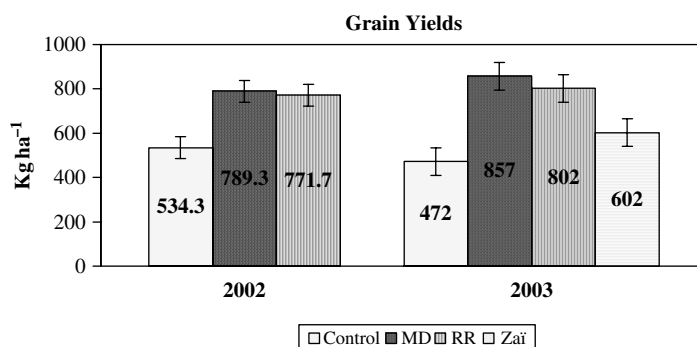

Figure 2. Sorghum Grain Yields (kg ha^{-1}) for Demonstration Trials (Control, Micro-Dose, Recommended Rates (RR), and Zai) in Burkina Faso, 2002 and 2003.

were trained in the correct application of the fertilizer “micro-dosing” technology. These training sessions consisted of demonstrating to them in the field how to measure the recommended rate of fertilizer (micro-dose), how to apply it correctly and how to manage the field after sowing. Emphasis was also put on the best way of collecting agronomic as well as socio-economic data from the trials set up.

Results

Burkina Faso

Grain yields

Overall, during both the 2002 and 2003 cropping seasons, grain and fodder yields from the micro-dosing treatments were higher than yields from the control treatments. In 2002 and 2003 millet grain yields from the micro-dose were, on average, 43% and 75% higher,

respectively, than yields from the control (Fig. 1). In 2003, the Zai treatment yielded 47% more than the control. During both 2002 and 2003 there was no significant difference between the grain yields from the micro-dose and the recommended rates of fertilizer broadcasting. Sorghum grain yields from the micro-dosing were 48% higher than those from the control plots in 2002 while in 2003 the micro-dosing treatments produced 82% more grain yield than the control treatments

(Fig. 2). There was no significant difference between yields from the micro-dosing and the recommended practice of fertilizer broadcasting.

Net returns

The revenue that was obtained with millet from the micro-dose treatment was approximately three times the revenue from the recommended practice (12575

FCFA ha⁻¹ as compared to 5175 FCFA ha⁻¹). For sorghum, it was about 2.5 times (22780 FCFA ha⁻¹ vs 9255 FCFA ha⁻¹)

Mali

Grain yields

In Mali, overall grain yields of both sorghum and millet obtained from the fertilizer micro-dosing plots were greater than those from the control treatments. In 2002, millet grain yields from the micro-dose treatments were about 61% greater than those from the control plots while the micro-dose treatment gave a 107% higher sorghum grain yields than the control plots (Fig. 3 and 4). In 2003, millet and sorghum grain yields from the micro-dosing plots were 90% and 69% higher than the control, respectively.

In Segou, sorghum grain yields from the micro-dosing treatments were significantly higher than those from the control plots (1069 kg ha⁻¹ vs 728 kg ha⁻¹). Millet grain yields increased from 687 kg ha⁻¹ under

no-fertilizer treatment to 1212 kg ha⁻¹ with fertilizer micro-dosing, a 100% increase. In Beledougou, sorghum grain yields were also significantly greater than the yields from the control plots (1050 kg ha⁻¹ vs 738 kg ha⁻¹). Millet yields from fertilizer micro-dosing were three times the yields from the control plots (688 kg ha⁻¹ vs 205 kg ha⁻¹).

ADAF-Gallé covered the zones of Beledougou and Mande. In Beledougou, sorghum grain yields from fertilizer micro-dosing plots were twice as much as those from the control plots (670 kg ha⁻¹ vs 300 kg ha⁻¹). This trend was also observed in the Mande region where sorghum grain yields from the fertilizer micro-dosing treatment were twice as much as the yields from the control plots (1300 kg ha⁻¹ vs 600 kg ha⁻¹). Yields were generally higher in the Mande than in Beledougou due to the relatively higher rainfall in Mande.

The zones where Winrock International established the tests included villages in Mopti and Segou. Sorghum grain yields increased from 500 kg ha⁻¹ to 800 kg ha⁻¹ when fertilizer was applied in small quantities in plant hills. In the Segou region yields have

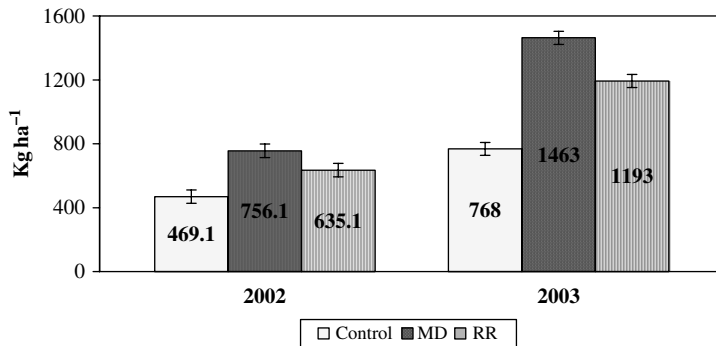

Figure 3. Millet Grain Yields (kg ha⁻¹) for Demonstration Trials (Control, Micro-Dose, and Recommended Rates (RR)) in Mali, 2002 and 2003.

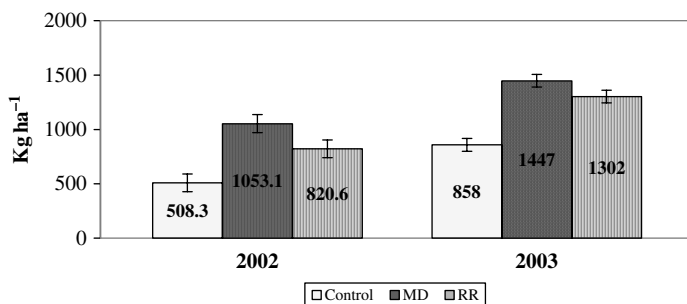

Figure 4. Sorghum Grain Yields (kg ha⁻¹) for Demonstration Trials (Control, Micro-Dose, and Recommended Rates (RR)) in Mali, 2002 and 2003.

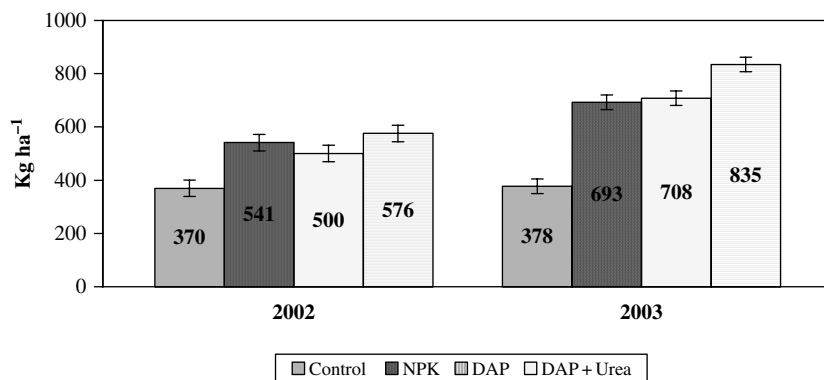

Figure 5. Millet Grain Yields (kg ha^{-1}) for Demonstration Trials (Control and Micro-Dose) in Niger, 2002 and 2003.

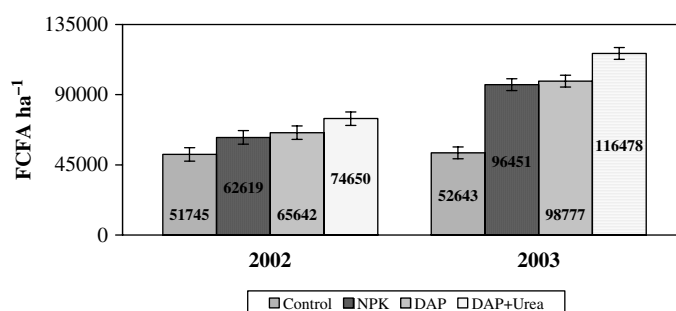

Figure 6. Net Profits (FCFA ha^{-1}) from Millet Grown Under Fertilizer Micro-Dosing Technology and Farmers' Practice, Niger, 2002 and 2003.

doubled under the fertilizer micro-dosing (1000 kg ha^{-1} vs 500 kg ha^{-1}).

Net returns

Net monetary gains obtained from millet from the micro-dosing plots were $119690 \text{ FCFA ha}^{-1}$ which were 68% higher than the net profits from the control ($71167 \text{ FCFA ha}^{-1}$) and 33% greater than the net gain from the earlier recommended rates ($89959 \text{ FCFA ha}^{-1}$).

Niger

Overall, fertilizer micro-dosing treatments yielded higher than the controls. In 2002, average grain yields of millet were 576 kg ha^{-1} for DAP+Urea, 500 kg ha^{-1} for DAP, 541 kg ha^{-1} for NPK and 370 kg ha^{-1} for the control treatment (Fig. 5). In 2003, the micro-dose treatments produced up to 120% more grain yields than the control treatment (Fig. 5).

Net returns

In 2002, net gains were 74650 FCFA for DAP + Urea, 65642 FCFA for DAP, 62619 FCFA for NPK and 51745 FCFA for the control (Fig. 6). Net profits from the micro-dose were 44% higher than the control plots in 2002 and 121% higher in 2003. (Fig. 6)

'Warrantage' or Inventory Credit System

This scheme enables the establishment of a link between credit and cereal grain markets. This credit facility removes the barriers to the adoption of soil fertility restoration technologies. Farmers can have access to credit to enable them purchase external inputs such as fertilizers and invest in income generating activities like fattening of small ruminants, horticulture, trading, etc., while using the stored grains to get higher prices at a time when the market supply begins to decline. In order to make inputs accessible to farmers, sustainable farmer-based enterprises and cooperative organizations

Table 1. Results from “Warrantage” in Mali, 2002/2003.

NGO Partner	Villages	Crops	Quantity of grain stored (kg)	Credit received under “Warrantage” (FCFA)	Management fees (FCFA)	Net benefits (FCFA)
SG 2000	Kondogola	Millet	4,000	360,000	4,000	236,000
		Niamabougou	Millet/	28,500	4,246,500	1,320,000
	Sélinkégny Tioribougou	Sorghum	2,000	580,000	79,000	Consumed
		Paddy	3,800	482,000	—	29,400 +
		rice	4,200	420,000	100,000	Consumed
		Maize/millet	4,130	619,500	10,500	196,000
		Paddy rice Sorghum				
ADAF/ Gallé	Kénioroba	Millet/ Sorghum	6,885	1,141,000	—	91,415
Winrock International	Tissa laSofara	Millet/	6,200	620,000	46,500	35,000
		Sorghum	13,107	638,375	—	215,547
		Paddy	902	126,280	49,925	Consumed
		rice Sorghum				

are developed, storage facilities and inputs shops (boutique d'intrants) are built, credit and savings schemes are also developed. These facilities are managed by members of these cooperatives.

Significant net benefits were achieved by farmers who practiced the “Warrantage” system in Mali in 2002/2003 (Table 1).

Training

Discussion

Results obtained from the demonstration trials in all the three participating countries confirmed the potential of this strategic application of fertilizer in the hill of plants (fertilizer “micro-dosing”). In general, grain yield increases under the fertilizer “micro-dosing” technology were more than twice as much as those from the control treatments. Net gain was also achieved by farmers using this technology. Earlier studies with fertilizer “micro-dosing” had been conducted mainly on millet grown in the sandy soils of Niger. The USAID TARGET project made it possible to evaluate this technology in higher rainfall areas with heavier soils in Burkina Faso and Mali. As was the case with millet in Niger, significant yield increases were also achieved with sorghum and millet at higher planting densities and in wetter environments.

The main concern of the project development partners relates to the socio-economic aspect of the technology in wetter areas where planting densities of sorghum and millet are usually higher than in drier areas thereby leading to larger quantities of fertilizer use per ha if the same rate of 6 grams of the compound fertilizer NPK or two grams of DAP fertilizer is applied. This shows that further studies are needed to come up with lower fertilizer application rates per hill in these cases. These studies are already in progress on research stations.

Another issue that requires further investigation is the possibility of soil mining arising from using the fertilizer “micro-dosing” technology. As grain yields increase per unit area and very little organic matter (OM), including crop residues, are put back into the soil there is the risk that nutrient imbalances will inevitably develop with time. There is therefore a need to ensure that OM is added and incorporated into these soils to improve their structure so that their capacity to store adequate moisture and nutrients even after crops are harvested is enhanced.

Labor could also be a major constraint to the wide adoption of the fertilizer “micro-dosing” technology. To further reduce the cost-benefit ratio, efforts should be made to develop labor-reducing equipment to complement the farmers efforts. The precise application of the fertilizer micro-dose in the hill of the plant requires that appropriate technology be developed and used.

The “Warrantage” or inventory credit system offers an excellent opportunity to farmers to get better prices for their grain products like sorghum and millet, to have access to cash credit and to purchase the needed inputs for increasing their agricultural productivity. The example from Mali given in this paper showed clearly that farmers can obtain great benefits from practicing the “Warrantage” system. There is, however, a need to strengthen farmers' organizations and assist them to establish effective linkages with financial stakeholders (commercial banks etc.) for additional funding.

Conclusions

In all the project study sites in the three West African countries (Burkina Faso, Mali and Niger), grain yields of millet and sorghum were greater by 43 to 120% when using fertilizer “micro-dosing” than with the earlier recommended fertilizer broadcasting rates and farmers' practices. The incomes of farmers using fertilizer “micro-dosing” and inventory credit system or “Warrantage” increased by 52 to 134%. Farmers associations were strengthened through training, technical back-stopping and exchange visits arranged among producers/farmers together with NGO staff from the three selected countries.

Acknowledgements

The authors are grateful to USAID for providing funding to carry out this study in the three participating countries, Burkina Faso, Mali and Niger.

We thank all the farmers, farmers' organizations and development partners for their active involvement in the execution of the field activities in all the three countries.

References

- Bationo A., Christianson B.C., Baethgen W.E. and Mokwunye A.U. 1992. A farm-level evaluation of nitrogen and phosphorus fertilizer use and planting density for pearl millet production in Niger. *Fert. Res.* 31: 175–184.
- Bationo A., Christianson B.C. and Klaij M.C. 1993. The effect of crop residue and fertilizer use on pearl millet yields in Niger. *Fert. Res.* 34: 251–258.
- Bationo A., Lompo F. and Koala S. 1998a. Research on nutrient flows and balances in West Africa: State-of-the art. *Agric. Ecosyst. Environ.* 71: 19–35.
- Bationo A., Ndjeunga J., Biolders C., Prabhakar V.R., Buerkert A. and Koala S., 1998b. Soil fertility restoration options to enhance pearl millet productivity on sandy Sahelian soils in south-west Niger. In: Lawrence P., Renard G. and von Oppen M. (Eds) *Proceedings of an International Workshop on the Evaluation of Technical and Institutional Options for Small Farmers in West Africa*, University of Hohenheim, Stuttgart, Germany, April 21–22, 1998. Margraf Verlag, Weikersheim, Germany, pp. 93–104.
- Breman H. 1990. No sustainability without external inputs. *Sub-Saharan Africa; Beyond Adjustment. Africa Seminar. Ministry of Foreign Affairs, DGIS, The Hague, The Netherlands.* pp. 124–134.
- Buerkert A. and Hiernaux P. 1998. Nutrients in the West African Sudano-Sahelian Zone: losses, transfers and role of external inputs. *J. Plant Nutr. Soil Sci.* pp. 365–383.
- Sivakumar M.V.K. 1992. Climate Changes and Implications for Agriculture in Niger. *Climate Change* 20: 297–312.
- Stoorvogel J.J. and Smaling E.M.A. 1990. Assessment of soil nutrient depletion in sub-Saharan Africa: 1983–2000. Report 28. Wageningen. The Winand Staring Center for Integrated Land, Soil and Water Research (SC-DLO), Wageningen, The Netherlands.
- Traore F. 1974. Etude de la fumure azotée intensive des céréales et du rôle spécifique de la matière organique dans la fertilité des sols du Mali. *Agron. Trop.* 29: 567–586.
- Van Keulen H. and Breman H. 1990. Agricultural development in the West African Sahelian region: a cure against land hunger? *Agric. Ecosyst. Environ.* 32: 177–197.

Advances in improving Agricultural Profitability and Overcoming Land Degradation in Savanna and Hillside Agroecosystems of Tropical America

M. Ayarza, E. Amézquita, I. Rao, E. Barrios, M. Rondón, Y. Rubiano and M. Quintero
Tropical Soil Biology and Fertility (TSBF) Institute of CIAT, A.A 6713 Cali, Colombia

I. Introduction

Savannas and hillsides are the most important agroecosystems of Tropical America. They comprise a total of 350 million ha and sustain a large rural population. With over 250 million ha, savannas in Bolivia (4 million), Brazil (180 million), Colombia (17 million), Guyana (4 million) and Venezuela (28 million) constitute the last major frontier for agricultural expansion in the region (Borlaug and Doswel, 1994).

Hillsides, on the other hand, cover three quarters of all land in southern Mexico, Central America and parts of the Caribbean region. Andean hillsides dominate the landscape of a considerable proportion of several countries in South America. They constitute the main source of water, forest and biodiversity for lowlands and, more importantly, they constitute the main resource for domestic food supply of maize, beans, potatoes and cassava (Scherr and Neidecker-Gonzales, 1997; Amézquita et al., 1998).

Developing knowledge and technologies to reverse land degradation and reduce poverty in these two regions are the major challenges faced by agricultural research. It is estimated that 75% of agricultural land in Central America and 45% of land in South America are showing degradation problems. Land degradation results in different combinations of losses of productivity, biodiversity, soil nutrients, soil carbon stocks, and soil biota.

Poverty is also a serious problem in hillsides. More than 60% of rural population in Honduras and Nicaragua and Guatemala are under the poverty line.

Population often contain a large group of people dominated by “vulnerable groups”, such as women-headed households, landless farmers, the young and elderly, indigenous people and ethnic minorities (Scherr, 2000).

In this paper we describe the major progress made by CGIAR Centers, NARS and local partners during the last thirty years to improve productivity and sustainability of production systems in tropical savannas and hillsides of Latin America. Main lessons learned in the process of land use change and adoption of improved technologies are also discussed.

II. Recent land use transformations in savannas and hillsides

The Cerrados of Brazil constitute the best example of the role of savannas to increase agricultural productivity and to respond to growing food demands by population. In the last 30 years there has been an impressive expansion of agriculture in this region. Today, there are more than 60 million ha planted with crops and improved pastures. Some estimates indicate that there is potential to increase by three-fold the agricultural land and increase productivity by 16 fold using improved management technologies (Macedo, 1996). Such level of expansion has been the result of intensive use of technology and inputs, good infrastructure and strong policy support.

Colombian and Venezuelan savannas are also experiencing rapid land use changes in spite of limited infrastructure and access to inputs. Large native savanna areas previously devoted to extensive cattle ranching

have been converted into productive pastures (6 million ha), annual crops (1.4 million ha) and forest plantations (0.9 million ha) (Rondón et al., 2006).

Hillsides have also experienced important economic and policy transformations during the last two decades. Governments and development agencies are investing to reduce poverty and improve education, road infrastructure and access to markets. Many countries are becoming important sources of high-value crops, for both national and export markets, particularly where higher altitudes allow production of coffee, temperate fruits and vegetables. This is uncovering an unprecedented potential for many tropical hillsides to become significant sources of agricultural supply and economic growth and employment (Scherr, 2000). In addition, there are important initiatives for regional integration.

III. Problems to develop sustainable production systems in Savannas and Hillsides

Savannas

Savanna soils under natural conditions have a low inherent productivity and are susceptible to rapid degradation. Around 75% of the soils are highly weathered Oxisols and Ultisols that are characterized by having low nutrient reserves, high soil acidity and phosphorus (p) fixation problems (Table 1).

These soils are also prone to soil compaction and erosion due to the intensive use of machinery and the highly erosive potential of rainfall (Amézquita et al.,

2004; Lopes et al., 2004). However, the susceptibility to compaction differs among savanna types. Soils of the Cerrados of Brazil, have in general, good physical conditions due to the strong microstructure inherited from its high content of iron sesquioxides (Neufeldt et al., 1999). Soils are deep, well drained, and have little presence of rocks and other physical impediments (Kanno et al., 2001). In contrast to this, soils of the Colombian savannas are relatively shallow, with low rates of water infiltration, and present problems of compaction and surface sealing (Amézquita et al., 1998a). Figure 1 shows bulk density values of soils for the Brazilian Cerrados and Colombian Llanos under different land management systems. Values are significantly lower for the Cerrados.

Lessons learned from agricultural expansion in the Brazilian Cerrados indicated that continuous crop monocultures and pastures are not sustainable in the long run. Declining crop productivity in these systems is accompanied by increasing costs, soil and water losses and a gradual built up of pests and diseases (Lopes et al., 2004). Amézquita et al. (1988) found a strong reduction in the total porosity and in percentage of macro and mesopores in a soil of the Colombian Llanos subjected to continuous cultivation to plant rice (Figure 2). The use of tillage implements (disc harrow) caused not only superficial sealing but also reduction in water infiltration thus affecting rainfall acceptance.

Pure grass pastures often decline in productivity after 4–10 years of grazing, the effect being faster in sandy soils (Boddey et al. 1996; Lopes et al., 2004). The decline of animal and grass productivity is followed by invasion of unpalatable weed species and the loss of

Table 1. Characteristics of some representative soil types found in the Cerrados of Brazil and Llanos of Colombia and Venezuela.

Site	Cerrados Planaltina, Brazil ⁽³⁾	Carimagua Colombian llanos ⁽¹⁾	Guarico Venezuelan llanos ⁽²⁾
Soil type	Typic Acrustox	Typic Haplustox	Ultisol
pH	4.8	4.5	5.1
SOC (%)	2.5	2.0	1.3
Effective CEC (cmol/kg)	0.13	4.2	4.6
Al saturation (%)	n.d	88.0	25.1
P (ppm)	2.0	3.9	—
K (cmol/kg)	0.05	0.08	0.4
Ca (cmol/kg)	0.04	0.18	1.4
Mg (cmol/kg)	0.05	0.06	0.9
Bulk density (0–20cm) (Mg/m ³)	0.84	1.38	1.46

(1) Rao, 1998; (2) Hernández and López, 2002; (3) Westerhof et al., 1998.

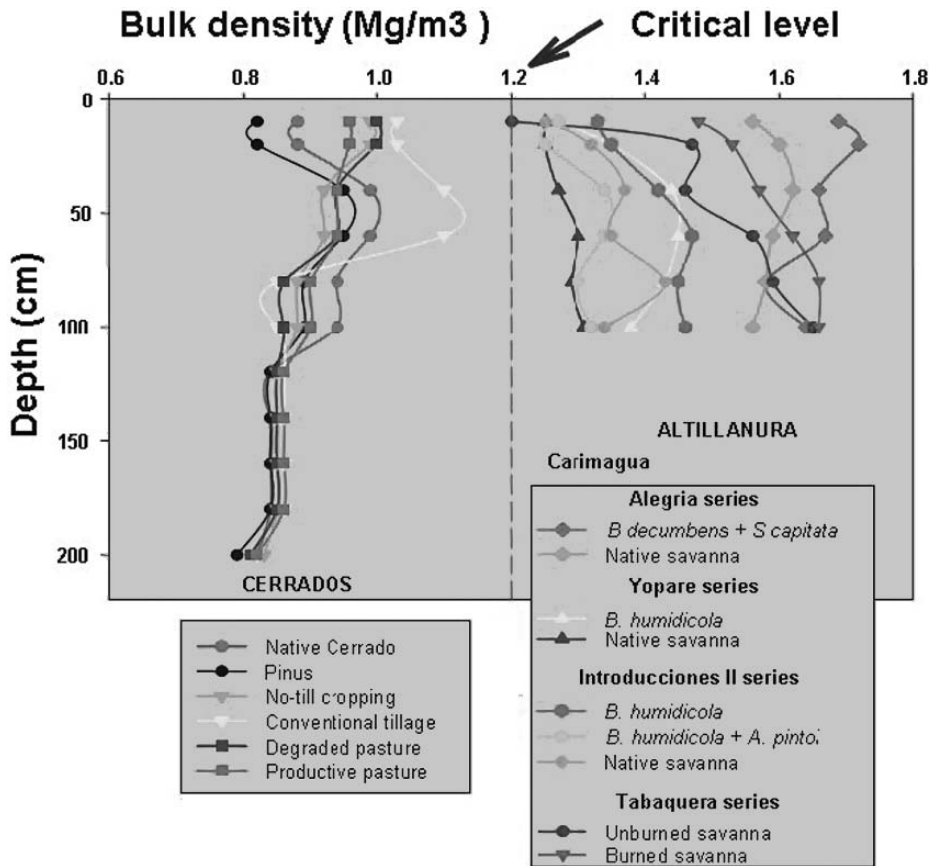

Figure 1. Effect of land use systems on bulk density of soils of the Brazilian Cerrado (Lilienfein et al., 1999) and the Colombian Llanos (E. Amézquita, unpublished data).

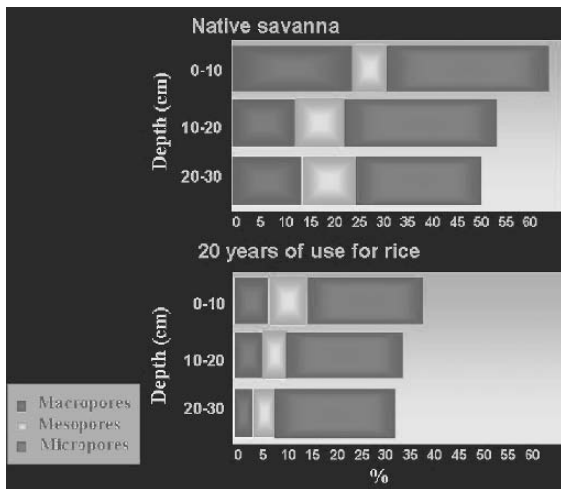

Figure 2. Effect of continuous cultivation of rice on percentage of soil macro, meso and micro-pores in an Oxisol of the Llanos of Colombia.

soil cover. Often the number of termite populations and number of mounds increase markedly (Boddey et al., 1996). Causes for pasture degradation are associated with N losses from the system and lack of maintenance fertilization (Spain et al., 1996). Degraded pastures produce less roots thus diminishing the capacity to take up nutrients and also, accumulate soil carbon (Rao, 1998).

Hillsides

Many hillside soils are of low intrinsic quality (shallow, phosphorus deficient, acid, rocky, etc). They require careful management and active soil-building efforts to maintain or increase yields (Scherr, 2000). Volcanic soils in Andean hillsides generally contain high amounts of soil organic matter (SOM) but nutrient cycling through SOM in these soils is limited because most of it is chemically protected, which limit the

Table 2. Soil chemical characteristics of the topsoil (0–20 cm) from three selected hillside sites in Nicaragua, Honduras and Colombia.

Site Soil type	San Dionisio ⁽¹⁾ Entisol and Inceptisol (Nicaragua)	Yorito ⁽²⁾ Entisol and Inceptisol (Honduras)	Pescador ⁽³⁾ Oxic Dystropepts (Colombia)
pH	5.6–6.4	6.2–8.0	5.1
SOM (%)	1.7–9.7	0.1–6.9	5.0
CEC (cmol/kg)	27.8–46.3	6.3–32.1	6.0
P (mg/kg)	8.5–56.9	9.0–15.0	4.6 ⁽⁴⁾
K (cmol/kg)	0.6–1.7	0.14–0.64	0.6 ⁽⁵⁾
Ca (cmol/kg)	20.7–38.3	2.5–25.1	2.5 ⁽⁵⁾
Mg (cmol/kg)	5.3–7.5	0.8–3.9	0.9 ⁽⁵⁾
Bulk density (Mg/m ³)	n.a	n.a	0.8

⁽¹⁾ and ⁽²⁾: MuMaSS annual Report 2003; ⁽³⁾: Barrios et al. 2004; ⁽⁴⁾ Bray II method, ⁽⁵⁾: Cobo et al. (2002a) n.a = not available.

rate of its decomposition (Phiri et al., 2001). Table 2 shows the characteristics of three hillside soils from Honduras, Nicaragua and Colombia.

Yet the most commonly noted environmental problems associated with hillside agriculture are nutrient depletion and soil erosion. Continuous cropping without replenishment of nutrients removed by crops, lead to a rapid exhaustion of native soil fertility. Steep slopes accelerate the movement of water downhill and without adequate soil cover and barriers, topsoil is transported off of farm fields, together with key nutrients (Scherr, 2000). As a result of this, SOM is depleted, waterholding capacity is reduced and, vulnerability to drought is increased. Furthermore, inappropriate tillage and over-grazing can lead to compacted soils.

The typical cropping cycle in the region includes monocrops or intercrops of maize (*Zea mays* L.), beans (*Phaseolus vulgaris* L.) and/or cassava (*Manihot esculenta* Crantz). Traditional management in hillsides of Central America is based on slash and burn of the native vegetation and previous crop residue before planting and little use of external inputs. In Andean hillsides slash and burn is followed by 3–5 years of cropping and then abandonment to fallow vegetation because of low crop yields (Knapp et al., 1996).

IV. Research strategies and technologies developed to overcome limitations

1. Savannas

1.1. Adapted crops for improved production systems

Most commercial crops do not tolerate the low fertility acid soil conditions prevalent in savannas and require the application of high doses of amendments

and fertilizers for economically viable production. Agricultural Research Institutions in Brazil developed during the 80–90s improved cropping systems for the Cerrados on the basis of soil fertility management technologies to correct topsoil and subsoil acidity, low availability of phosphorus and micro-nutrient deficiencies (Lopes et al., 2004). Today it is common to obtain more than 3 t/ha soybeans, 6–8 t/ha maize and 3 t/ha of common beans using improved soil fertility management technologies and high yielding varieties. Perennial crops such as coffee and citrus are also expanding rapidly in the Cerrados. All this change has been largely possible due to the ample availability of lime and P deposits throughout the region.

Research institutions working in the Colombian savannas followed a different approach. Instead of relying on application of large amounts of amendments and fertilizers they focused on selecting germplasm tolerant to soil acidity and low nutrient availability. Collaborative research between the Colombian Institute for Agricultural Research (ICA) and International Research Centers such as CIAT (rice and cassava), INTSORMIL (sorghum), and CIMMYT (maize) and ICRISAT (sorghum and millet) has led to the identification of crops tolerant of Al, and with high production potential (Table 3).

New upland rice varieties are able to tolerate more than 70% Al saturation and can be planted using less than one-ton lime/ha. Soybean and maize varieties are able to tolerate up to 55% of Al saturation levels and can be planted using 2–4 ton/ha of lime depending on soil type (Valencia and Leal, 2004). Studies on mechanisms for Al resistance in maize indicated that exudation of organic acids such as citric acid plays a key role for improved adaptation to acid soil conditions (Gaume et al., 2001).

Table 3. Yield of conventional and acid-tolerant crop varieties developed for the Llanos of Colombia.

Crop	Traditional varieties		Improved Varieties	
	Commercial Name	Yield (t/ha)	Commercial Name	Yield (t/ha)
Soybean	Soyica P-34	1.8	Soyica P-34	3.0
Maize	Corpoica H-108	4.0	Pioneer 3041 – Monsanto 4004	7.5
Rice	Oryzica Sabana 10	3.2	Altillanura 11	5.0
	Altillanura 11 (Linea 30)	3.8	Altillanura 11	5.0
Cassava	Brasilera (consumption)	25	Corpoica Vergara (Industry)	30

Source: Molina D.L. personal communication.

1.2. Forage grasses and legumes for improved livestock systems

Until 30 years ago, the most common land use system in the Cerrados and Llanos was extensive cattle ranching based on native grass species. Today, there are more than 48 million ha in the Cerrados and 6 million ha in the Llanos of Colombia and Venezuela planted with exotic grasses introduced from Africa, such as *Brachiaria spp.*, *Panicum* and *Andropogon spp.* (Macedo, 1995; Rondón et al., 2006).

A portfolio of new grass and legume species is now available as a result of the collaborative work between NARS and CGIAR Centers. In Brazil, EMBRAPA conducted for several years a collaborative research program with CIRAD to exploit genetic variability and adaptation of *Panicum spp.* to the Cerrado environment. More than six new *Panicum* varieties have been selected and are widely spread in several countries of Latin America.

On the other hand, the Colombian Institute for agricultural research ICA and the Tropical Pasture/Forage Program of CIAT adopted the strategy of selecting acid-tolerant forage grass and legume species and developing low-input management techniques to establish selected materials. This strategy relied on the selection of promising cultivars from the CIAT forage germplasm collection that contains more than 20,000 accessions.

Using a regional network (RIEPT) for germplasm evaluation new acid-tolerant germplasm options are now available (*Brachiaria brizantha*, *Brachiaria humidicola*, *Brachiaria dictyoneura*, *Paspalum*, and *Panicum*) and legumes (*Arachis*, *Stylosanthes*, *Desmodium* and *Cratylia*). Adaptation to acid soils is associated with mechanisms at the root level to tolerate high Al saturation levels (Figure 3). For Al resistance, the grass *Brachiaria* shows considerable

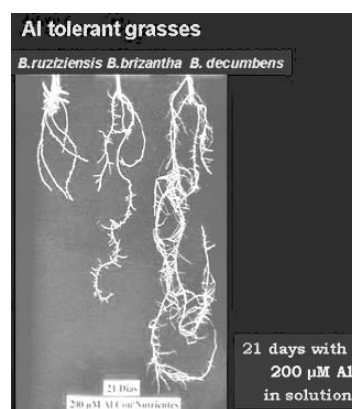

Figure 3. Effect of aluminium in solution on root growth of three *Brachiaria* species in a greenhouse experiment.

variation. For example, *B. decumbens* cv. Basilisk is much more resistant to Al toxicity than are the other *Brachiaria* species. A rapid and reliable screening procedure was developed, based on findings from physiological studies, to identify Al-resistant genotypes and improve the efficiency of CIAT's on-going *Brachiaria* breeding program. The use of such screening methods will help breeders develop superior genotypes that combine several desirable traits to improve pasture productivity and combat pasture degradation (Rao, 2001).

The potential impact of improved grass and grass-legume pasture associations to increase animal productivity has been clearly demonstrated in several experiments conducted in the Llanos of Colombia. Figure 4 shows that grass-legume pastures have the capacity to double animal live weight gains (LWG) and increased productivity per hectare by 10 fold compared with a managed native savanna.

Animal gains on improved pastures have also been accompanied by enhanced soil fertility. A grazing

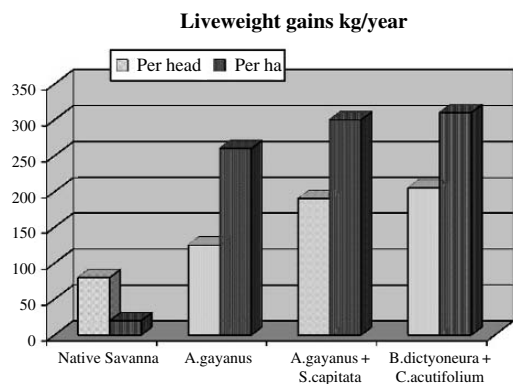

Figure 4. Impact of pure grass and grass–legume pastures on animal productivity in an Oxisol of the Colombian Llanos (Adapted from Thomas et al., 1995).

experiment that was planted in the Carimagua Research Station in 1980 with the grass *B. decumbens* CIAT-606 alone and in association with strips of *Pueraria phaseoloides* CIAT 9900 (kudzu) showed that after 10 years the SOM content in the 0–2 cm soil of the pure grass and grass/legume pastures was higher than the savanna control (Rao et al., 1994).

Legume carbon contributed up to 29% of the total soil carbon found in the topsoil of the grass-legume pasture (Rao et al., 1994). Potential N mineralization was also higher in the pasture association. This type of improvement was probably responsible for the extra 1.7 t/ha rice grain obtained in plots planted on the grass-legume pasture (Table 4). This was equivalent to the application of 86 kg N fertilizer/ha in the pure grass pasture (Thomas et al., 1995).

Improved pastures had also a very important impact on soil macrofauna, especially on earthworm populations. Decaëns et al. (2001) reported increased earthworm biomass from 4.8 to up to 51.1 g/m² under several grass pastures. *B. decumbens* + *P. phaseoloides* improved not only population but also maintained

diversity of earthworm populations. The authors indicated that these results can be associated with the better quality of the legume residues.

1.3. Rice-pasture systems

Grass pastures could perform well for several years if managed properly with maintenance fertilizer application. However, once they degrade due to biotic or abiotic constraints, economic factors limit their reclamation. These pastures require a minimum capital investment for adequate establishment and reclamation and, usually farmers are not willing to invest in these practices (Vera and Seré, 1985). One strategy is to establish or reclaim pastures using maize, soybeans and upland rice as pioneer crops (Kluthcousky et al., 2004; Sanz et al., 2004).

Sanz et al. (2004) conducted several trials in the Eastern Plains of Colombia to test the feasibility of planting acid-tolerant upland rice varieties in association with improved grass-legume pastures. The work was conducted at two sites in the Eastern Plains of Colombia, both Oxisols (isohyperthermic Tropeptic Haplustox) with a pH of 4.5 and low nutrient availability: Ca < 0.2 meq/100 g; Mg < 0.08 meq/100 g; K (0.1 mg/kg). Aluminium saturation was greater than 80%. Field trials included planting of rice in monocultures, rice association with grass-legume pastures and rice planted after pastures. Fertilizer treatments included varying rates of N and P and land preparation methods (early and late preparation methods).

Results showed that new upland rice lines planted simultaneously with pastures produced more than 2 t/ha and did not show significant yield reduction (Table 5). Rice crop accumulated more nutrients than did the pastures, but pastures competed with rice especially for P, K and Mg. Besides obtaining a good rice crop, pastures were well established and ready for light grazing.

Table 4. Yields of a rice crop sown after a 10-year-old grass or grass/legume pasture.

Year	Grain yeild (t / ha)	
	B.decumbens	B.decumbens + kudzu
1989	1.36 ± 0.17	3.07 ± 0.26
1990	1.40 ± 0.21	2.22 ± 0.21

The rice crop received 0 N and 25 kg P ha⁻¹ ± S.E.
Source: From Thomas et al., 1995.

Table 5. Rice grain yield and pasture biomass in monocropped rice and rice in association with several grass-legume pastures planted in an Oxisol of the eastern plains of Colombia.

Treatment	Dry matter (t/ha)			
	Rice (t/ ha)	Grass	Legume	Weeds
Monocrop	2.23	–	–	0.65
Rice+Brachiaria decumben/centrosema acutifolium	2.09	1.22	0.21	0.67
Rice+Andropogon gayanus/stylosanthes capitata	1.95	1.77	0.44	0.43
LSD ₀₀₅	0.52	0.59	0.14	0.22

Rice/Grass-legume pastures associations combine the large financial benefit of an annual crop in the short term with the long-term increase in animal productivity and improved soil quality. Rice/pasture systems also improve soil nutrient status through the direct application of the most important elements as fertilizers, nitrogen fixation by legumes, and increased SOM resulting from the abundant biomass of the associated pasture.

1.4. Integrated crop/pasture systems

In more recent years considerable research has been done on the integration of crops and pastures systems over time and space. The main advantages of this type of integration are based on the potential synergism between annual and perennial components in terms of enhanced soil fertility, increased biological activity, more efficient nutrient cycling, enhanced soil physical properties and controlled weed, pests and diseases.

A successful case of integration was documented by Ayarza et al. (2004a) in a farm near Uberlandia, Brazil. With the introduction of agricultural activity to the Santa Terezhina farm in 1983, the original system of calf fattening based on old *Brachiaria* pastures was transformed into an integrated system, in which cycles of crops and pastures were alternated. Figure 5 shows that by 1992, all the original pastures of *B. decumbens* had been replaced by pastures of *P.maximun*, planted simultaneously with maize after 3–4 year cycle of cropping.

Despite the reduction in pasture area by 60%, the number of animals in the farm remained almost the same because of the higher carrying capacity of pastures after crops. This resulted in an increase in the calf productivity as compared to traditional systems (Table 6).

During the crop cycles fertility was improved because of the use of fertilizers and amendments.

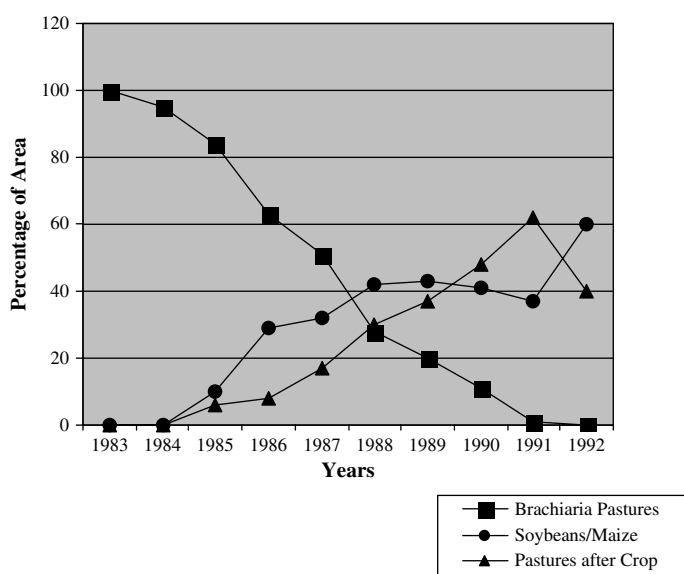

Figure 5. Dynamics of land use change in the Santa Terezhina farm as a result of the integration of crops and pastures over time and space.

Table 6. Economic efficiency of calf production in three farms in Uberlandia, Brazil with different degrees of intensification.

Parameter	Management System		
	Traditional	Improved	Crop/pasture
Pasture reclaimed/year (%)	1	10	25
Age of pasture (years)	15–20	10	5
Hectares/cow	1.85	1.3	0.96
Calves/ha	2.8	5.7	6.6
Gross income/ha (US\$)	43	95	110
Area in pastures	1728	2110	416
Total gross income (US\$)	74,304	200,459	45,760

Source: Fisher (unpublished).

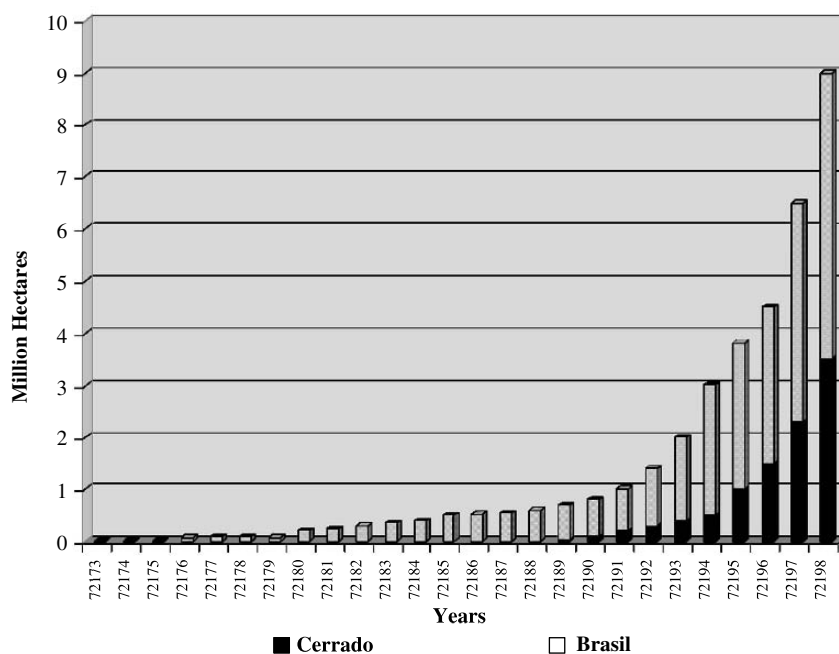

Figure 6. Dynamics of adoption of no-till systems in Brazil.

During the pasture cycle, soil aggregation and SOM improved due to the large root biomass of pasture (Ayarza et al., 2004). Carbon, N and P content in the macroaggregates were also enriched (Lilienfein et al., 1998). The farmer is now planting crops using no-till practices on mulch of chemically controlled *Panicum* pastures.

1.5. No-till systems

Probably more important than the “cerrado revolution” that occurred in the 70’s was the “no-tillage revolution” that started in the 1980s in Brazil and spread rapidly in the 90’s. In 1980 this system was applied to 150,000 ha,

increasing to 1 million ha in the 90’s and then to almost ten million ha in 1998 (Figure 6). No-till systems are applied to more than 2 million ha in the Cerrados. According to Landers (2001) expansion of no-till systems was driven by (i) farm-tested and cost-effective technology, (ii) awareness of benefits, (iii) technical training, (iv) removal of serious soil physical and chemical constraints and problem weeds, (v) availability of cover crops, (vi) credit or small grants for small farmers and (vii) enabling legislation for community management of micro-watersheds. Farmer to farmer contact with integrated support from private sector, NGOs, government, and some international agencies were the prime factors for successful dissemination. Smith

et al. (1999) conducted a survey in a Cerrado region of Uberlandia, Brazil about reasons behind adoption of no-till systems. Results indicated that policies are also important for the adoption of the system. They create conditions for asset accumulation by farmers during the good times and allow them to embark on profound changes during a period of financial stress.

The system is based on three main principles: minimizing soil disturbance, covering the soil with plants or plant residues for as long as possible and rotating crops. Lopes et al. (2004) summarized the different types of no-till that have been developed. They basically range from no-till with cover crop as a winter crop to no-till with a living cover crop of a legume.

Green manures and cover crops play an important role on crop productivity and soil quality as they reduce water losses by evaporation and improve soil aggregation by the release of organic substances.

Before the 90's, adoption of no-till by small-scale farmers was limited. They could use the same crop rotations, herbicides and cover crops as large-scale farmers but lacked technology for planting by hand or with animals. To solve this problem three development projects in Paraná State in Brazil financed by the World Bank fostered the development of adequate planters and provided strong technical support to small farmers (Ayarza et al., 2004b). Those producers that adopted the system recognized the benefits of the system in terms of more stable crop production, reduced labour and more time left for other activities.

1.6. The need of developing an arable layer prior to move to no-tillage systems in the Colombian Llanos

Initial attempts of farmers of the Colombian Llanos to plant crops using no-till failed, because of the intrinsic vulnerability of these soils to lose topsoil structure (Amézquita et al., 1998). Thus, to sustain the productivity of crop-livestock systems, they require proper diagnosis of soil constraints and management strategies to minimize degradation. The concept of "Arable Layer" was developed by Amézquita et al. (1998) to improve soil quality, to raise crop-livestock productivity over time and to minimize environmental degradation. Once an arable layer is built-up, soils can go to no-tillage systems.

Developing an arable layer requires the use of vertical tillage (chisels) to overcome the soil/physical constraints, application of small amounts of lime and fertilizers to overcome the chemical constraints and use of acid soil adapted tropical forage germplasm

to improve soil organic matter content and biological activity. Use of vertical tillage and application of lime and fertilizer facilitate rapid growth and turnover of the vigorous root systems of tropical forage grasses (*Brachiaria* and *Panicum*) and contribute to marked improvements of topsoil quality.

Research conducted in close collaboration with CORPOICA and other partners in the Llanos of Colombia indicated that building-up of an arable layer in tropical savannas is not only economically attractive but also technically feasible to farmers that are increasingly adopting this technology. Work conducted by Rivas et al. (2004) analyzed the profitability of three alternatives to building-up an arable layer (Table 7). All the alternatives had positive financial returns. However, net returns were better when crop cycles of three years were followed by the establishment of a pasture.

1.7. Improved understanding of nutrient dynamics

Knowledge of the short- and long-term fate of P fertilizer in relation to different management practices is essential for the sustainable management of tropical savannas.

Field studies conducted by Friesen et al. (1997) quantified the residual effectiveness of P fertilizer inputs in tropical savannas in the Llanos of Colombia, in cereal-legume rotations (maize-soybean or rice-cowpea) and ley pasture systems. Results indicated that applied P moves preferentially into labile inorganic P pools, and then only slowly via biomass production and microbes into organic P pools under both introduced pastures and crop rotations. Similar results were reported for the Cerrado soils of (Neufeldt et al., 1999). These results indicate that applications of soluble P to Oxisols remain available for periods of time, which are much longer than expected. This has important implications on the residual value of P fertilizer applications.

Legume-based pastures are more deep rooted than crops and acquire considerable amounts of P despite a much lower level of available P than in the surface soil. These differences in rooting strategies have important implications for P acquisition efficiency in relation to available soil P in different crop and pasture systems. Greenhouse studies confirmed that forage legumes are more efficient in acquiring P per unit root length than grasses (Rao et al., 1997). Comparative studies of a forage grass (*Brachiaria dictyoneura* CIAT 6133) and a legume (*Arachis pintoii* CIAT 17434) demonstrated that the legume could acquire P from relatively less

Table 7. Economic performance of three alternatives to build-up an arable layer in soils of the Llanos of Colombia.

Alternatives	Time required for the development of the arable layer (years)	Indicators of profitability	
		Net present Value (Thousands of pesos/ha)	Internal Rate of return (%)
Alternative 1:			
✓ Establishment of a grass pasture	5	113	19.9
✓ Three years of grazing			
✓ One year of rotation with crops			
Alternative 2:			
✓ Establishment of a grass + legume pasture	5	511	37.4
✓ Three years of grazing			
✓ One year of rotation with crops			
Alternative 3			
✓ Three years of crop rotations	4	660	57.4
✓ Establishment of a pasture through simultaneous sowing with a crop			

Source: Adapted from Rivas et al., 2004.

available P forms from Oxisols of Colombia (Rao et al., 1999).

Mineralization of organic P is a more important mechanism for delivering available P in improved grass-legume pastures than in continuously cropped soils. Oberson et al. (2001) found that the amount and turnover of P that is held in the soil microbial biomass is increased when native savanna is replaced by improved pasture while it was lowered when soils are cultivated and cropped continuously. Based on these studies, an alternative strategy is proposed to cropping low P Oxisols using of lower amounts of P fertilizer to crops and planting of grass-legume pastures to promote P cycling and efficient use of P inputs. Thus legume-based pastures could be considered as important land use options to stimulate P cycling, reduce P fixation and minimize soil degradation in tropical savannas.

1.8. Potential ecosystem services provided by improved-production systems

1.8.1. Nitrification inhibition Nitrogen fertilizer, which is mostly applied in the (NH₄⁺) form, is rapidly converted into NO₃⁻ by soil bacteria. However, when converted into NO₃⁻, it is highly susceptible to leaching, thus entering into water streams and ground-water bodies. Thus, keeping a greater proportion of fertilizer N in NH₄⁺ form is one of the major goals of nitrogen management.

CIAT scientists for the first time, reported the existence of mechanisms of inhibition of nitrification in the

soil under pastures of *Brachiaria humidicola* (CIAT 679) in the Llanos of Colombia (Sylvester-Bradley et al., 1988; CIAT, 2004b)). Subsequently, JIRCAS, Japan showed that root exudates of this tropical grass has a strong nitrification inhibition effect. Recently, a rapid and reliable bioassay using a recombinant *Nitrosomonas* strain was developed to assess quantitatively the inhibitory activity on nitrification in root exudates, and plant/soil extracts. Using this bio-assay it was found that there is considerable genetic variability among different *Bracharia humidicola* genotypes (CIAT, 2004a).

Identification of crop and forage cultivars with a range of inhibition capabilities can facilitate the development of management systems to minimize nitrification-associated N losses in densely populated rural areas where, intensification of agriculture through N and water inputs are currently at its highest. Management and genetic strategies that address the issue of nitrification inhibition could consequently make a significant contribution to enhance rural livelihoods and improve human and environmental health.

1.8.2. Carbon accumulation Improved management technologies in agriculture, livestock and forestry in Latin America that are able to sequester atmospheric carbon in the biomass or in the soils will make an important contribution to agricultural sustainability. Data from a long-term experiment conducted in Typic Haplustox of the Carimagua research station in the

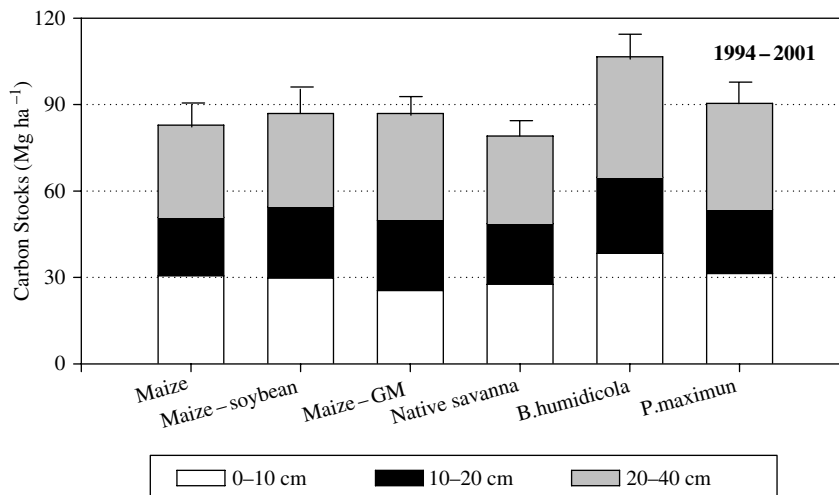

Figure 7. Soil carbon stocks under a long-term experiment on clay-loam Oxisols from central Colombian Llanos.

middle of the Colombian Llanos, to study the sustainability of different land use options was used by Rondón et al. (2006) to estimate carbon accumulation in the soil. Continuous cultivation of upland rice, maize and rotation of these two crops with soybean or cowpea were evaluated during a 8 year period. Other systems included grass-legume pastures (*B. humidicola* and *A. pintoi*; *Panicum maximum* and *Pueraria phaseoloides*) and native savanna.

At the time of establishment in 1993, a detailed soil sampling was conducted in the area. Soil C was determined to 40 cm depth with 5 cm increments to 20 cm and then for every 10 cm depth. Soil bulk density was measured for the same soil increments. The plots were monitored annually until the end of the experiment in 2003. Total carbon stocks as well as stocks in each soil layer increment for the maize based systems were calculated.

As shown in Figure 7, the conversion of native savannas into pastures of *B. humidicola* and *A. pintoi*, resulted in net increases in soil C stocks of 25 Mg Cha⁻¹ over 8 years. Very similar rates of SOC accumulation (3 Mg Cha⁻¹y⁻¹) have been reported on pastures of *B. dictyoneura* associated with *Centrosema macrocarpum* on a sandy soil from well drained plains in Venezuela (Hernández et al., 2004). These results confirm previous findings (Rao, 1998; Trujillo, (2000) in clay-loam soils from central Llanos in Colombia, indicating that introduced pastures can significantly enhance total C in soils.

Figure 7 also shows that most of the accumulation in grasses occurs in the top 10 cm of the soils. This

may be the result of higher influence of litter added to surface layers and also of the high biomass of roots concentrated in that layer. Rao (1998) evaluated different grasses in the same area and indicated that introduced grasses have up to 5.7 Mg ha⁻¹ of root biomass compared to 1.4 Mg ha⁻¹ for native savannas down to 80 cm depth. He also observed that up to 73% of the root biomass from the grasses is concentrated in the top 20 cm layer. Trujillo (2000) found that standing root biomass was about three times more in pastures of *B. dictyoneura* (8.6 Mg ha⁻¹) than in native savanna (2.9 Mg ha⁻¹).

Given the relative small area converted into crops and the reported low or no losses of C due to cultivation in the region, agriculture and forestry are not seen to have caused large impact on total stocks of C in soils from the Llanos.

1.8.3. Greenhouse gas emission Measurements of the emission of greenhouse gases (GHG's) from different land uses in the Colombian Llanos were carried out by Rondón et al. (2002). Figure 8 shows the global warming potential of various land uses calculated for 20 and 100 years scenarios. The main conclusion of this work is that the introduction of improved grass/legume pastures is estimated to convert the savannas from a net source of global warming potential into a net sink. This is due to the low emissions of methane and nitrous oxide from pastures and the very high sequestration of atmospheric CO₂, as soil organic carbon.

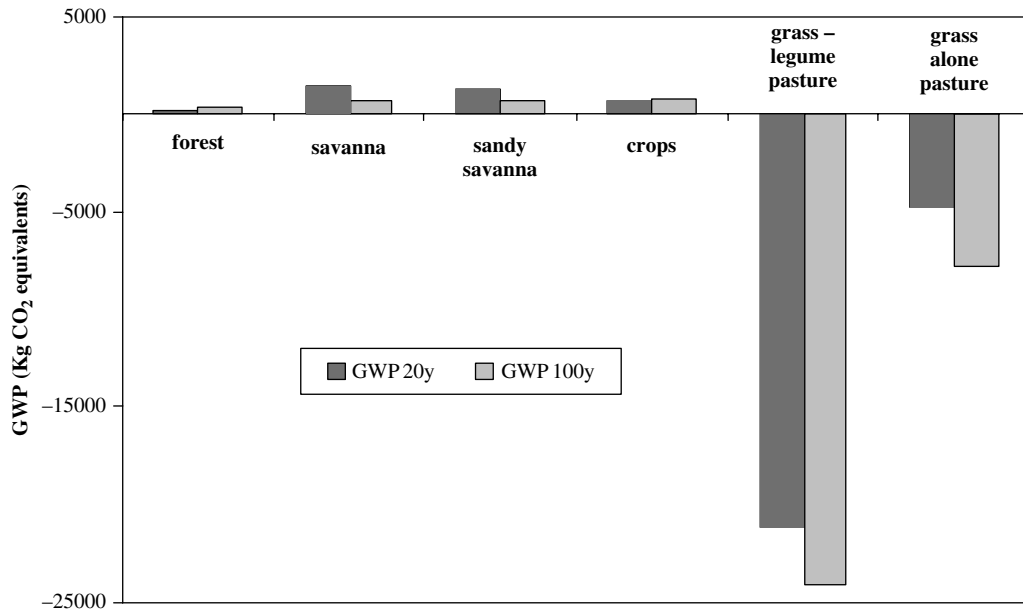

Figure 8. Global warming potential for various land uses in the Llanos of Colombia under two time horizon scenarios (20 and 100 years), expressed as Kg CO₂ equivalents. Values represent the contribution of annual emissions per hectare.

1.9. Decision support tools for Land-use planning

Researchers at CIAT developed a land-use planning tool for the Colombian savannas known as “GEOSOIL” (Rubiano, 2005). This tool allows decision-makers to store, consult and process soil data at several scales of resolution (plot, farm, community and country). The morphological and analytical elements of the soils are combined to form indicators of soil quality and to qualify the constraints for different agricultural purposes. The system has several modules that deliver information regarding suitability of a given soil type for a given land use, major constraints and produce outputs linked to visual observation using mapmaker or Spring. The system now is in the process of validation.

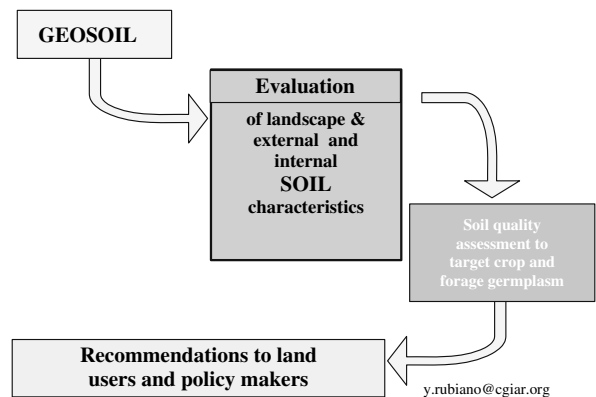

Figure 9. Main components of the GEOSOIL.

1.10. Decision tree: A decision support tool to define land use alternatives in Colombian tropical savannas.

To confront the land degradation process and to avoid loss of productivity as time of use elapse, in the Colombian savanna soils, a decision support tree was developed by a group of researchers at CIAT. The decision tree permits to give Altillanura soils, the best land use possible for high productivity, but at the same time to conserve the natural resources. The decision tree is a decision support tool that indicates what kinds of land use is more appropriate and sustainable based

on soil texture and topography characteristics. It was constructed based on local and technical knowledge developed during scientific research in the Colombian tropical savanna landscape.

This tool combines the use of both the SPRING and MapMaker Popular GIS packages and the Microsoft Access 2000 database software, with which the decision rules were programmed in Visual Basic. Decision rules can be applied on soil and topography characteristics specified by the user for a given point, or on the characteristics stored in a table corresponding to the units (polygons) of a soil map.

When a soil and unit topography characteristics are specified for a given location, the application presents a menu of soil textures, ranges of slope and effective soil depth from which to take a land use decision. As a result of the application of the decision tree, the tool proposes a range of potential land uses. The number of production system options increase as soil depth increases and slope decreases. In the cases where the soil characteristics constraints the land use of a farm or soil unit, the tool proposes practices for the improvement of soils, using the concept of generation of an arable layer. This is recommended especially where the soil depth is low. Land practices are suggested, to improve soil characteristics of Colombian savannas to increase productivity and to gain in sustainability.

The results of the analysis are displayed through text and spatial reports. The maps are generated, one for each land use option, when the decision tree is applied

on soil units characteristics (1:100.000 scale) in the soil map. To spatialize these results in GIS software, soil and slope characteristics were coded according to the values used in the decision tree. The polygons or soil units in soil maps generally correspond to groups of soils that can have different characteristics. The percentage area that each soil represents in the polygon is indicated in the tables accompanying the maps. The polygons are colored according to the percentage of soil, which is suitable for each option (Figure 10).

The spatial reports are visualized through a Map-Maker Popular customized application elaborated with all the maps resulting from the analysis of the soil maps, for each of the 13 land use options considered.

The database tool was designed to allow a modification of the decision tree to adapt it to other localities, or simply to allow soil researchers to revise the decision rules as the research in the savannas progresses.

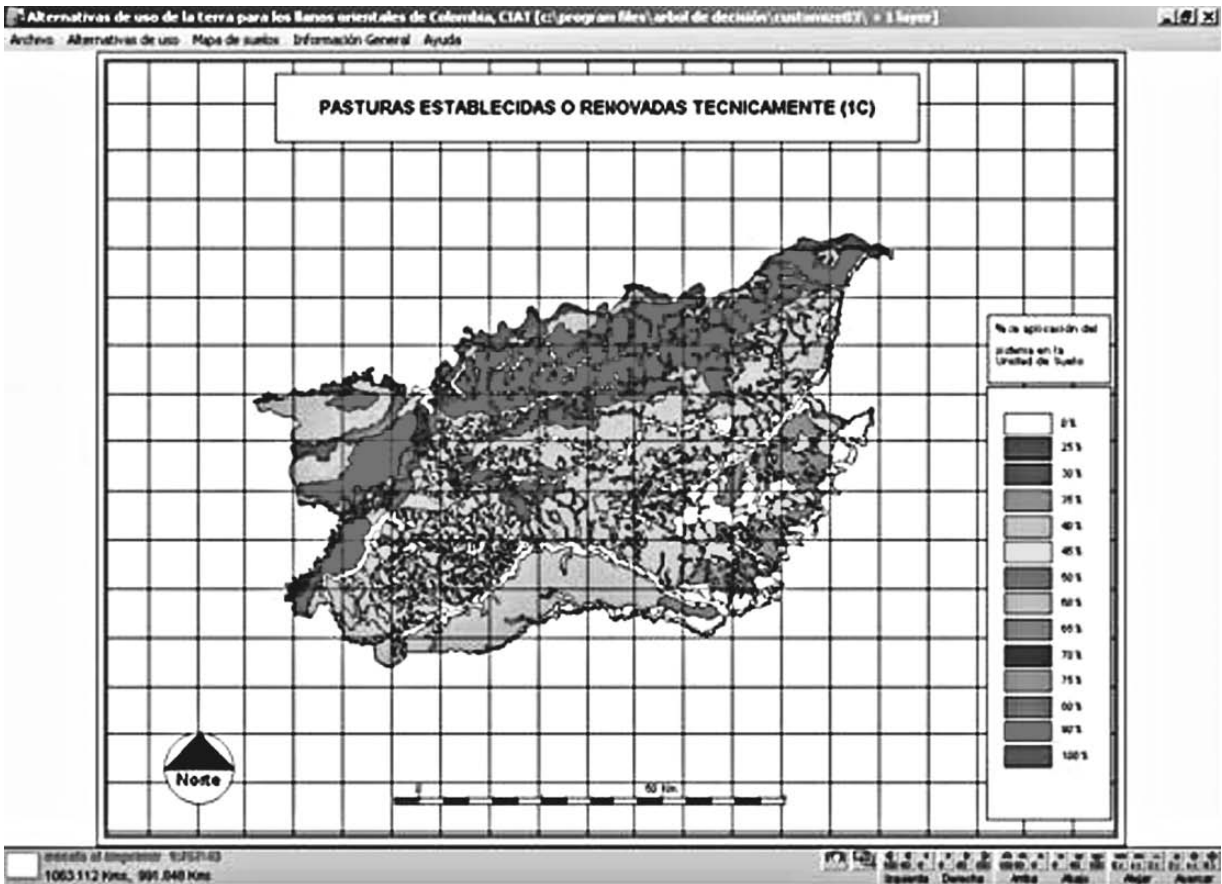

Figure 10. Mapping of areas recommended for pastures to be established and renovated for each 5 years as a function of the percentage of area of each polygon having adequate soil characteristics for that land use.

Through the use and adaptation of this tool with partners, users can combine their knowledge into decision trees, work out how local stakeholders can use these, and then adjust the decision rules through monitoring of the results of the adoption of the proposed options.

1.11. Partnerships, synthesis of information and capacity building

Development of a large body of knowledge and technologies to improve management of acid-soil savannas was only possible because of the collaborative effort made by researchers from national agricultural research institutions, universities of developing and developed countries and International Research Institutions like IRD and CIAT. They worked for 7 years (1994–2000) in representative sites of the Cerrados and Colombian savannas to: 1) characterize the agroecology of acid soil savannas; 2) to develop sustainable land management practices and, 3) to identify indicators of land quality.

As a result of this partnership, major advances were made on the understanding of effect of land use on soil biological and chemical properties of savanna soils. These outputs were synthesized and delivered to the technical and scientific community in three books: 1) *Agropastoral systems for the Tropical Savannas of Latin America*; 2) *Nature's Plow: Soil Macroinvertebrates in the Neotropical savannas of Colombia* and 3) *Sustainable Land Management of the Oxisols of the Latin American savannas* and in 57 publications in refereed journals and 10 refereed book chapters. In the process, 51 students were trained and obtained their degree (27 B.Sc, 14 MSc and 10 Ph.D). This achievement was awarded by the CGIAR with a prize of excellence in science as the most Outstanding Partnership in 2002.

2. Hillsides

New technical advances by CGIAR Centers and partners in the region include; 1) more adapted and more productive crop and pasture germplasm to improve productivity and profitability of production systems for smallholders; 2) management systems more efficient in the use of water and nutrients; 3) decision support systems to improve Natural Resource Management; 4) participatory research methods and 5) tools for information management.

2.1. Improved germplasm to intensify and diversified production systems

Programs to identify and develop crop and pasture germplasm more productive and more adapted to biotic and abiotic stresses prevalent in Hillsides have been conducted by NARS and CGIAR centers for more than 20 years. CIAT, CIMMYT and CIP have established regional networks of NARS to conduct field evaluation of most promising germplasm of beans and cassava, maize and potatoes respectively. Most current varieties available to small farmers in the region have been developed through these networks.

2.1.1. Drought tolerant germplasm Because of the increasing farmer concern about potential hazard of drought CIAT and CIMMYT, in collaboration with their partners, have been developing a number maize and bean cultivars that are more tolerant to water stress and to low nutrient availability for hillsides of Central America. CIMMYT has developed several varieties able to allocate more carbohydrates to grain, which allows them to produce more grain with less moisture. The new breeds also show up to 10% increase in grain yield during non-drought seasons.

On the other hand, the new bean materials developed by CIAT are capable to withstand severe water stress events. They combine the mechanisms of deep rooting ability with photosynthate mobilization to grain, which contributes to greater grain filling during terminal stress conditions (Beebe et al., 2003).

Sorghum is an excellent alternative to dry regions given its superior drought tolerance in comparison to maize. New varieties having improved grain yields and fodder quality are becoming available through the INSORMIL network and the CIAT-CIRAD project.

Cassava is another important option for drought prone areas. It is highly adapted to dry conditions through physiological mechanisms of drought avoidance. It is rapidly being transformed from a traditional staple into a market-oriented commodity. Roots provide raw material for small-and large-scale processing into livestock feed and starch. CIAT has been able to develop high yielding genotypes and has identified good genetic stocks to improve levels of vitamins and minerals in the roots and leaves.

Cowpea is also a promising crop for dry hillsides. It could provide not only grain for food consumption, but could also be used as a hay for feeding ruminants and small animals during the dry season or contribute to soil fertility enhancement for the following maize crop (Rieber, 2004). The forages project has identified

several cowpea accessions with potential to increase maize production when used as green manures.

Recently, CIAT and its partners have developed new forage options for hillsides using agronomic evaluation, genetic enhancement and farmer participatory approaches. Two grasses (*Brachiaria brizantha* cv Toledo and *Brachiaria* hybrid cv Mulato) and a shrub legume (*Cratylia argentea*) have demonstrated great potential to intensify production in livestock systems for small holders during the dry season (CIAT, 2004b).

2.2. Improved production systems

2.2.1. New cropping systems New crop options to diversify traditional maize-based systems are currently under testing in several hillside sites in Honduras and Nicaragua. CIAT introduced in 2001 improved germplasm from other CGIAR Centers: 1) sweet potatoes varieties from CIP with potential to improve diet of the family; 2) early growing soybean varieties from IITA with potential to produce good yields and large amounts of biomass to recycle nutrients and ; 3) upland rice varieties from CIRAD resistant to diseases and able to tolerate water stress and cold temperatures.

Promising materials are being assembled in novel crop rotation systems in the field. Preliminary results obtained by the TSBF-CIAT project in Yorito, Honduras and San Dionisio Nicaragua indicate that it is possible to replace the traditional maize-bean system by soybean-maize, rice-beans and bean-sorghum rotation systems. Results of small plot experiments showed that there is a synergistic effect between improved crops and enhanced soil fertility to intensify and diversify hillside agriculture. In the near future it will be possible to plant more than three crops per year and introduce market oriented crops in rotation with maize-based systems.

2.2.2. Agroforestry systems Agroforestry systems that intercrop or strip crop perennials with grains offer opportunities for diversification and conservation in hillside ecosystems. Although different models have been tested in hillsides of Central America perhaps the most widely adopted is the “Quesungual” agroforestry system. This system has been a critical option in achieving food security by more than 6,000 poor farmers living in hillsides of Honduras (Ayarza and Alvarez-Welchez, 2004).

In the “Quesungual” system dispersed native trees remaining in cropping fields and through periodic pruning, competition is kept low while provision of plant

residues for soil cover is maintained for soil moisture conservation and as a source of nutrients (Hellin et al., 1999; Alvarez-Welchez and Cherret, 2002). Annual crops (maize, sorghum, beans) and pastures are planted with fertilizers, using no burning and zero tillage/direct planting operations on a permanent soil cover. This enabled farmers to intensify and diversify their production systems. Crop yields increased by more than 100% (maize from 1200 to 2500 kg/ha, beans from 325 to 800 kg/ha) in comparison to the traditional slash and burn system. The main economic gains of the QSMAS are: 1) improved income; 2) less labour for land preparation and weed control; 3) reduced cost of production, and 4) higher net profits (Clercx and Deugd, 2002).

TSBF-CIAT and partners in the region are identifying the main management principles driving the resilience of the system and validating the system in dry areas of Nicaragua and Colombia.

2.2.3. Improved Fallows In some areas of Andean hillsides, a considerable proportion of land (about 25–30%) remains under natural fallow every year. Planted fallow agroforestry systems are an appropriate technological entry point given their low risk for the farmer and, the potential to generate additional products (i.e. fuel-wood) that bring immediate benefit while improving soil fertility.

Fallow improvement studies conducted by Barrios et al. (2005) indicated that the *Tithonia* planted fallow agroforestry system, under slash and mulch management, was the best option to contribute to the rapid restoration of soil fertility by increasing the plant available P pool in the soil that is the limiting nutrient in the study area (Phiri et al., 2001). The study was conducted on soils following 3 years of cassava cultivation at two farms in Pescador, Cauca, Colombia.

The potential for soil fertility recovery after 12 and 28 months was evaluated with two fast growing trees, *Calliandra calothyrsus* Meissn (CAL) and *Indigofera constricta* L.(IND), and one shrub, *Tithonia diversifolia* (Hemsl.) Gray (TTH), under slash and mulch management compared to the natural fallow management (NAT) used by farmers when the soils become unproductive. All planted fallow agroforestry systems produced greater biomass than the natural fallow. Greatest cumulative dry weight biomass (37 Mg ha⁻¹) was produced by TTH (Barrios and Cobo, 2004). Nutrient levels in the biomass were especially high for TTH. Soil parameters most affected by planted fallow agroforestry systems included soil total N, available N (ammonium and nitrate), exchangeable cations (K, Ca,

Mg and Al), amount of P in light fraction, soil bulk density and air permeability, and soil macrofauna diversity (Barrios et al., 2005).

Tithonia planted fallow agroforestry systems, however, may not be suitable to areas with seasonal drought as it is not tolerant of extended dry periods.

Conversely, the *Calliandra* planted fallow agroforestry system proved to be the most resilient option as it produced similar amounts of biomass independent of initial level of soil fertility and tolerated seasonal droughts (Barrios and Cobo, 2004). Its slower rates of decomposition, compared to *Indigofera constricta* and *T. diversifolia* indicated that benefits provided may be longer lasting (Cobo et al., 2002b). The *Indigofera* planted fallow agroforestry system was least adapted to low soil fertility and this may limit its potential for extended use.

2.3. Improved soil conservation and fertility management

2.3.1. Multipurpose legumes Deteriorating soil fertility, low productivity, low income and lack of animal feed are problems faced by smallholders in the hillsides of Central America. To address these challenges CIAT has been investigating the potential role of several multipurpose legumes. In this context, several species of *cowpea* and *Cannavalia* have been identified as promising components for alternative cropping systems. They can play an important role in animal feed, soil improvement and human nutrition. Since 2001, the Tropical Forages Project of CIAT has conducted agronomic and participatory research on different *cowpea* and *Cannavalia* accessions in Honduras, Nicaragua and Colombia. The results obtained so far, have shown that maize yields increase when it is planted after green manures of these two species (A. Schmidt, pers comm.). The contribution of several green manure species was estimated to be equivalent to the application of 70 kg/ha N (Figure 11). These results are under validation with farmer groups in San Dionisio, Nicaragua.

Similar experiments conducted in Cauca, Colombia have shown that intercropping of cassava with legume cover crops reduced soil loss and improved nutrient acquisition by cassava (CIAT, 1999).

2.3.2. Dual purpose live barriers Development projects in many hillside areas have spent in the past a large amount of resources to stimulate the adoption of barriers by small farmers in hillsides of Honduras

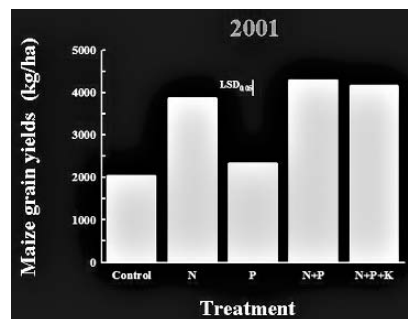

Figure 11. Mean effect of N, P and K applications on grain yields of maize planted in several farms of San Dionisio, Nicaragua (Source: CIAT, 2003a).

and Nicaragua. Different types of barriers have been developed (contour barriers, live barriers, etc.). Unfortunately, they have been seldom adopted because of the extra-labor required to establish them and the lack of short-term economic benefits. Therefore, new approaches are required to integrate this soil conservation technology into farming systems. CIAT developed the concept of “multiple purpose barriers” to solve this problem. It is based on the use of species that are able to protect the soil, improve soil fertility and provide feed and food for farmers.

Field studies conducted in the Andean hillside of Cauca, Colombia identified elephant grass as an effective grass barrier to reduce soil erosion in Andean hillsides. It produces greater root biomass (9.3 t/ha) than the Imperial grass (4.2 t/ha). The greater root length density (per unit of soil volume) of this species contributed to its superior acquisition of N, P, K and Ca from soil (Zhiping et al., 2003). In addition, the abundance of very fine roots reduced soil losses from the topsoil. Besides of the benefits to retain soil and nutrients, elephant grass is commonly used in cut and carry feeding systems.

Another promising barrier that has received increasing attention in recent years is sugar cane. Sugar cane live barriers control soil erosion and loss by reducing the speed of water flow down the slope and also by promoting the formation of natural terraces as a result of retention and accumulation of soil from higher positions in the slope. Sugar cane live barriers also have the capacity to produce sufficient brown sugar to satisfy an important part of household consumption and to generate additional income given mean yields of about 2 kg of brown sugar for every meter of sugarcane barrier (CIAT, 1999).

2.3.3. Methods to diagnose nutrient constraints to crop production Simple and reliable methods are needed to assess nutrient deficiencies at the farm level. Several years ago the TSBF program in Africa developed the nutrient strips methodology to diagnose N, P and K deficiencies. This methodology was applied to diagnose nutrient limitations in several farms of Yorito, Honduras and San Dionisio, Nicaragua to show farmers the extent of nutrient depletion in their own plots. Average results of 21 on-farm trials conducted in San Dionisio Nicaragua showed that N is the most limiting nutrient for maize production (Figure 11). Single applications of P were not sufficient to improve yields. The methodology is being validated under a broader set of conditions with partners in the region.

2.3.4. Soil quality Indicators Land degradation is a major concern in the Central American region. However, there is a lack of standardized field methods enabling farmers, local organizations and policy makers to assess the impact of interventions on soil fertility. During the past few years CIAT and its partners in the region have been developing local indicators of soil quality by combining technical and local knowledge into a user-friendly decision support tools. One example of this is the Guide on Local Indicators of Soil Quality developed by Barrios et al. (2001). Farmers using this guide are able to assess the condition of their own soil using parameters that are not only relevant for them but also meaningful for the scientific community.

Simple and reliable field methods have also been developed to assess the stage of important soil physical and biological parameters such as water infiltration, runoff, aggregate stability, resistance to penetration Herrick et al. 2004, Améezquita et al. 2000, Cobo, 1999, Campo, 2004). Figure 12 shows some of the devises developed to measure these parameters in the field.

Biological indicators of soil quality successfully used in Latin America and Africa include light fraction N, N mineralization and density of the parasitic weed *Striga* that were found sensitive to land use and management and also directly related to maize grain yield (Barrios et al., 1998; Basamba et al., 2005). Near infrared reflectance spectrometry (NIRS) has also shown to be a useful and resource saving methodology to evaluate soil organic matter and was found significantly related to soil macrofauna (Velasquez et al., 2005). Local biological indicators of soil quality commonly used by farmers include native plants and soil macrofauna (i.e. earthworms) which have also been found sensitive to land use and management practices (Barrios and Trejo, 2003).

2.4. Information Management Systems

CIAT and CIMMYT have compiled and published databases on levels and geographic location of commodity production, markets, input use, etc., for rigorous analysis of trends of focus commodities. CIAT

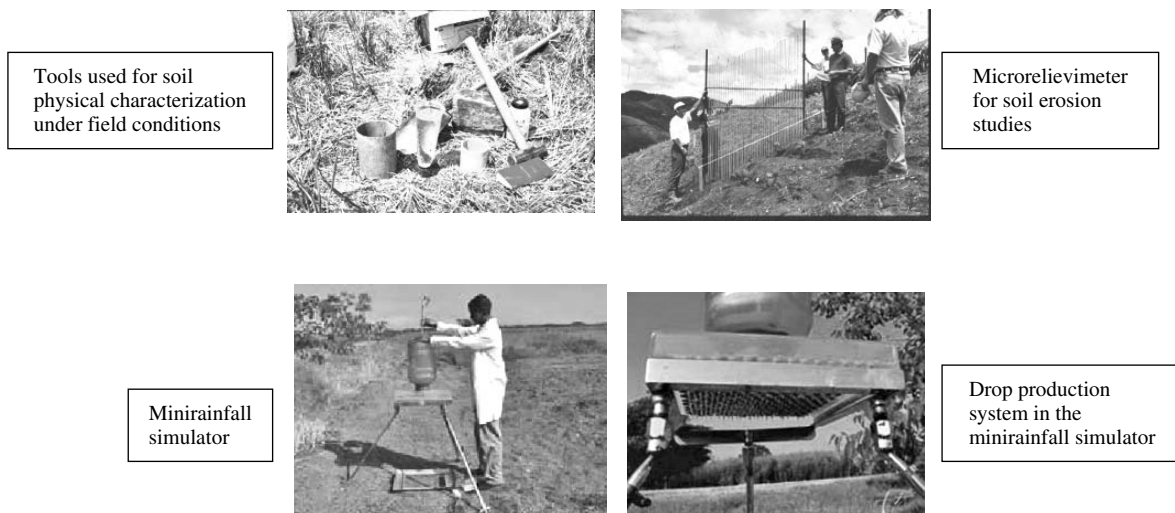

Figure 12. Field tools developed by CIAT to assess soil degradation in hillside areas.

extended the concept to develop geographic information systems that integrate data on climate, topography, population, agricultural production of diverse commodities, and selected ecological variables. The intention is to explore the dynamics of agricultural response to biophysical and socio-economic factors. Important products of this effort are the CIAT's Atlas of Honduras and Atlas of Sustainability Indicators for Latin America and the CIP's GIS system for the Andes.

2.5. Watershed management

Impact of the decisions made by communities on Natural Resource Management at the landscape level is difficult to assess. This requires tools and methods to integrate biophysical and socioeconomic indicators into a coherent analytical framework and the development of solutions that go beyond the biophysical domain. The Communities and Watershed Project activities in the Cabuyal Watershed of Colombia, the Yoro Watershed of Honduras and the Calico Watershed of Nicaragua are developing base-line indicators of change. The CIP project for upper watersheds of the Andes is following a similar approach.

These projects are identifying social and biophysical hotspots within pilot watersheds and are developing technical and institutional innovations that are introduced, together with development partners, and then evaluated in terms of their development impact. The communities within the study watershed typically evaluate innovations.

2.6. Knowledge management and capacity building

The new knowledge gained (new germplasm, improved management technologies, new tools and information systems) is disseminated to a wide audience using different pathways. These methods include: 1) journal publications for researchers; 2) training workshops, collaborative planning workshops, cross-site visits, videos and presentations for extensionists and project managers; 3) policy briefs, articles and press releases for policy makers and 4) pamphlets in local languages; radio programs; videos; farmer-to-farmer diffusion, presentations to farmer organizations for farmer groups. FAO is launching the TECA digital platform to improve access to information in order to enhance and improve the adoption of proven technologies in agriculture, livestock, fisheries and forestry.

The dissemination of new knowledge requires a continuous process of strengthening the capacity of stakeholders to validate and adapt technological innovations and to share results with others. To do this, CIAT and other CGIAR Centers are facilitating the development of local and regional networks to improve management of Natural Resources. One example of this is the regional Consortium for the Integrated Management of Fragile Soils of Central America, MIS. The other is the Consortium for the sustainable management of the Andes CONDESAN. CIAT and CIP are supporting training on cutting-edge bio-physical methodologies, laboratory techniques and field methods to improve management of soil, water and nutrients. Staff from Universities and development Projects in Honduras, Nicaragua and Honduras are engaged into this process within the MIS Consortium.

3. Conclusions

Savannas and Hillsides have the potential for dramatic increases in food production in a short-term. The information presented in this paper illustrates clearly the fundamental role that research institutions have played to achieve this potential and to improve its sustainability.

Research conducted by several CGIAR, NARS and local partners in the region has resulted in the following concrete outputs: 1) identification of main biophysical constraints for savannas and hillsides, 2) development of crop and pasture germplasm with potential to increase productivity and improve system resilience; 3) new production systems and improved soil management technologies to intensify and diversify productivity and generate income; and 4) decision support tools to improve decision making in natural resource management at several scales (plot, farm, community, etc.). All this has been accompanied by an effective effort to improve the scientific capacity of partners to use and adapt new knowledge and to share results with other stakeholders.

Savanna and Hillside research could also contribute in several ways to arrest land degradation and deforestation. Available technologies will permit to relieve current pressure on native forests in hillsides and revert degradation problems observed in Llanos and Cerrados. Researchers could also identify or develop a range of land management designs and practices to protect watersheds under a variety of land uses, and

help to devise effective strategies for buffer zone management or low environmental impact forest use. They can identify land uses and practices that will increase carbon sequestration while allowing local people to economically utilize or replace natural forests.

However, to exploit fully this potential there is a need for policy initiatives to provide a support to institutional environment and for development investments.

Most NARS in developing countries remain weak in the biophysical and socio-economic disciplines required to generate solutions for savannas and hillsides. For this reason the role of networks is quite important in strengthening the capacity of stakeholders of using and adopting knowledge and technologies to solve savanna and hillside problems on a very broad scale.

Acknowledgements

The work reported in this review resulted from multidisciplinary research activities conducted collaboratively with the Rice, Tropical Forages and Land Use projects of CIAT together with our partners in the national research programs of Colombia (CORPOICA), Nicaragua (INTA) and Honduras (DICTA). We also acknowledge the research support for this work from D. Molina, P. Hoyos, M. Rivera, J. Cobo, N. Asakawa and J. Ricaurte. This work was partially supported from the funds of the Ministry of Agriculture and Rural Development of Colombia.

References

- Alvarez Welchez, L and I. Cherret. 2002. The Quesungual systems in Honduras: Alternative to slash-and-burn. In: magazine on Low Input and Sustainable Agriculture (LEISA). pp. 10–11. October, Vol. 18 No 3.
- Amézquita, E., G. Preciado, D.M. Arias, R.J. Thomas, D.K. Friesen and J.I. Sanz. 1998a. Soil physical characteristics under different land use systems and duration on the Colombian savannas. 16th World Congress of Soil Science. Montpellier, France (poster presentation).
- Amézquita, E., Ashby, J., Knapp, E.B., Thomas, R., Muller-Samman, K., Ravnborg, H., Beltrán, J., Sanz, J.I., Rao, I.M., and Barrios, E. 1998b. CIAT's strategic research for sustainable land management on the steep hillsides of Latin America. In: "Soil Erosion at Multiple Scales: Principles and Methods for Assessing Causes and Impacts". Penning de Vries, F.W.T., Agus, F. & Kerr, J. (eds.) pp. 121–132. CABI/IBSRAM, Wallingford, Oxford, UK.
- Amézquita, E., L. Cobo Q., and E.A. Torres. 2000. Diseño, construcción y evaluación de un minisimulador de lluvia para estudios de susceptibilidad a erosión en áreas de laderas. Presented at the 11th International Soil Conservation Organization Conference (ISCO) "Land Conservation and Food Production in the Third Millennium". Buenos Aires, Argentina. October 22–27, 2000.
- Amézquita, E., Thomas, R.J., Rao, I.M., Molina, D.L. and Hoyos, P. 2004. Use of deep-rooted tropical pastures to build-up an arable layer through improved soil properties of an Oxisol in the Eastern Plains (Llanos Orientales) of Colombia. *Agriculture, Ecosystems and Environment* 103: 269–277.
- Ayarza, M.A., L.Vilela, E.A. Pizarro and P.D. da Costa. 2004a. Agropastoral systems based on multiple-purpose legumes. pp. 185–202. In: *Agropastoral Systems for the Tropical Savannas of Latin America*. Editors. E.P. Guimaraes, J.I. Sanz, I.M. Rao, M.C. Amezquita, E. Amezquita, R. Thomas. Cali, Colombia. Centro Internacional de Agricultura Tropical (CIAT): Empresa Brasileira de Pesquisa Agropecuaria (Embrapa). 342 p.
- Ayarza, M.A., R. Ralish and J.G. Abi-Saab. 2004b. Drivers effecting development and sustainability of no-till systems for small-holders at the watershed level in Brazil. Bright Spots Project Comprehensive Assessment Program Report. International Water Management Program, IWMI. (In Press).
- Ayarza, M.A., and L.A. Welchez. 2004. Drivers effecting the development and sustainability of the Quesungual Slash and Mulch Agro forestry System (QSMAS) in hillsides of Honduras. Bright Spots Project Comprehensive Assessment Program Report. International Water Management Program, IWMI. (In Press).
- Barrios E, Trejo M.T. 2003 Implications of local soil knowledge for integrated soil management in Latin America. *Geoderma* 111: 217–231.
- Barrios E, Cobo J.G 2004. Plant growth, biomass production and nutrient accumulation by slash/mulch agroforestry systems in tropical hillsides of Colombia. *Agroforestry Systems* 60: 255–265.
- Barrios E, Kwesiga F, Buresh RJ, Sprent JJ, and Coe R (1998) Relating presason soil nitrogen to maize yield in tree legume-maize rotations. *Soil Science Society of America Journal* 62(6): 1604–1609.
- Barrios E, Bekunda M, Delve R, Esilaba A, and Mowo J. 2001. Identifying and classifying local indicators of soil quality. Eastern Africa Version. Participatory Methods for Decision Making in Natural Resource Management. CIAT-SWNM-TSBF-AHI.
- Barrios E, Cobo JG, Rao IM, Thomas RJ, Amézquita E, Jimenez JJ, Rondón M (2005) Fallow management for soil fertility recovery in tropical Andean agroecosystems in Colombia. *Agriculture, Ecosystem and Environment* (in press).
- Basamba T, Barrios E, Singh BR, Rao IM (2007) Nitrogen and Phosphorus availability, organic matter fractions and maize yield under follows and Manure Management on a Colombian volcanic-ash soil. *Journal of Sustainable Agriculture* (in press).
- Beebe, S., I. Rao, H. Terán and C. Cajiao. 2003. Breeding concepts and approaches in food legumes: The example of common bean. Invited paper presented at the "Second National Workshop on Food and Forage Legumes". Addis Ababa, Ethiopia. 22–27 (in press).
- Boddey, R.M, B.J.R. Alves and S. Urquiaga. 1996. pp. 33–38. Nitrogen cycling and sustainability of improved pastures in the Brazilian cerrados. In: Pereira R.C.; Nasser L.C. eds. *Simposio sobre o Cerrado*, 8 EMBRAPA.-CPAC, Planaltina, DF Brazil.
- Borlaug, N.E. and C.R. Doswell. 1994. Feeding a human population that increasingly crowds a fragile planet. Keynote address at the 15th World Congress of Soil Science. Acapulco, México. Suppl.1–15.

- Campo Quesada, J.M. 2004. Evaluación de la susceptibilidad a la erosión hídrica, del contenido de material orgánico y de las propiedades físicas, en Oxíc Dystrustept bajo seis historias de uso intensivo, en Pescador-Cauca mediante el uso de un minisimulador de lluvia. Thesis BsC. Facultad de Ingeniería y Administración, Universidad Nacional de Colombia, Sede Palmira. 138 p.
- CIAT, 1999. Annual Report Project PE-2: Overcoming soil degradation through productivity enhancement and natural resource management. Annual Report. 160 p.
- CIAT, 2003 a. Annual Report Tropical Soil Biology and Fertility Program.
- CIAT. 2003b. Annual Report Tropical Forages Project.
- CIAT. 2004a. Annual Report Tropical Soil Biology and Fertility Program.
- CIAT. 2004b. Tropical Forages Project. Annual Report. 216 p
- Cobo, L., and E. Amézquita. 1999. Diseño, construcción y evaluación de un minisimulador de lluvia para estudios de susceptibilidad a erosión en laderas. *Revista Suelos Ecuatoriales* 29(1): 66–70.
- Cobo JG, Barrios E, Kass DCL and Thomas RJ. 2002a. Decomposition and nutrient release by green manures in a tropical hillside agroecosystem. *Plant and Soil* 240: 331–342.
- Cobo JG, Barrios E, Kass DCL and Thomas RJ (2002b) Nitrogen mineralization and crop uptake from surface-applied leaves of green manure species on a tropical volcanic-ash soil. *Biology and Fertility of Soils* 36: 87–92.
- Decaens, T, P. Lavelle, J.J. Jimenez, G. Escobar, G. Ripstein, J. Schneidmadl, J.I. Sanz, P. Hoyos, and A.G. Moreno. 2001. Impact of land management on soil macrofauna in the Eastern Plains of Colombia. In *Nature's Plow: Soil Macroinvertebrate Communities in the Neotropical Savannas of Colombia*. Eds: J.J. Jimenez and R.J. Thomas. Cali, Colombia: Centro Internacional de Agricultura tropical, 2001, 389 p. CIAT Publication no: 324. ISBN 958-694-038-1.
- Friesen, D.K., Rao, I.M., Thomas, R.J., Oberson, A., and Sanz, J.I. 1997. Phosphorus acquisition and cycling in crop and pasture systems in low fertility tropical soils. *Plant and Soil*, 196, 289–294.
- Gaume, A., Machler, F., and Frossard, E. 2001. Aluminum resistance in two cultivars of *Zea mays* L.: Root exudation of organic acids and influence of phosphorus nutrition. *Plant and Soil* 234: 73–81.
- Hellin J, Welchez L,A and Cherrett, I (1999) The Quezungal system: an indigenous agroforestry system from western Honduras. *Agroforestry Systems* 46: 229–237
- Hernández-Hernández, R.M. and D. López-Hernández. 2002. El tipo de labranza como agente modificador de la materia orgánica: un modelo para suelos de sabana de los Llanos Centrales Venezolanos. *INTERCIENCIA*. 27(10): 529–536
- Hernández-Hernández, R.M., Z. Lozano, C. Bravo, B. Moreno and L. Piñango. 2004. Alternativas para el mejoramiento de la productividad del sistema maíz-ganado en suelos del Estado Guárico. Proyecto FONACIT. Venezuela. 257 p.
- Herrick, J., J.V. Zee, K.M. Havstad, L. Burkett and W. Whifordt. 2004. Monitoring Manual for Grassland, and Scrubland and Savanna Ecosystems. Vol I and II. USDA-ARS. Jornada Experimental Range. Las Cruces, New México.
- Kanno, T., M.C.M. Macedo, S. Uozumi, V.P.B. Euclides, J.A. Bono, Y. Yoshimura, M.R. Correa and J.D.G. Santos Jr. 2001. Development of grassland management technology for sustainable agropastoral systems in the sub-tropical zone in Brazil. In: Kanno, T. and M.C.M. Macedo (eds). JIRCAS/EMBRAPA Gado de Corte. International Joint Workshop on Agropastoral System in South America. JIRCAS Working Report No.19, January 2001. pp. 63–73.
- Knuthcouski, J, I.P de Oliveira, L.P. Yokoyama, L.G Dutra, T. de Portes, A.E. da Silva, B. Da S. Pinheiro, E. Ferreira, E. Da M de Castro, C. M. Guimaraes, J. De C. Gomide and L.C. Balbino. 2004. The Barreirao System: Recovering and Renewing Degraded Pastures with Annual Crops. In: *Agropastoral Systems for the Tropical Savannas of Latin America*. Editors. E.P. Guimaraes, J.I. Sanz, I.M. Rao, M.C. Amezcuita, E. Amezcuita, R. Thomas. Cali, Colombia. Centro Internacional de Agricultura Tropical (CIAT): Empresa Brasileira de Pesquisa Agropecuaria (Embrapa). 342 p.
- Knapp, B., Ashby, J.A. and Ravnborg, H.M. 1996. Natural resources management research in practice: the CIAT Hillside Agroecosystem Program. In: Press, H-J.A., ed., *Agricultural Research and Sustainable Management of Natural Resources*. LIT Verlag, Munster-Hamburg, Germany, pp. 161–172
- Landers, J. 2001. How and Why the Brazilian Zero Tillage Explosion Occurred. Pages 29–39. In: D.E. Stott, R.H. Monther and G.C. Steinhardt (eds). *Sustainable the Global farm*. Selected paper from the 10th International Soil Conservation Organization meeting held in May 24–29, 1999 at Purdue University and the USDA-ARS National Soil Research Laboratory.
- Lopes, A.S, M. Ayarza and R.J. Thomas. 2004. Managing and Conserving Acid savanna soils for Agricultural Development: Lessons from the Brazilian Cerrados. pp. 11–41. In: *Agropastoral Systems for the Tropical Savannas of Latin America*. Editors. E.P. Guimaraes, J.I. Sanz, I.M. Rao, M.C. Amezcuita, E. Amezcuita, R. Thomas. Cali, Colombia. Centro Internacional de Agricultura Tropical (CIAT): Empresa Brasileira de Pesquisa Agropecuaria (Embrapa). 342 p.
- Lilienfein, J., W. Wilcke, H. Neufeldt, M. Ayarza and W. Zech 1998. Land-use effects on Organic Carbon, Nitrogen and Sulphur concentrations in macroaggregates of differently textured Brazilian Oxisols. *Z. Pflanzenernähr. Bodenk.*, 161, 165–171.
- Lilienfein et al. 1999. Annual course of matric potential in differently used savanna Oxisols in Brazil. *Soil Sci. Soc. Am. J.* 63: 1778–1785.
- Macedo, J. 1996. Prospectives for the rational use of the Brazilian Cerrados for food production. EMBRAPA-CPAC, Planaltina, DF, Brazil.
- Macedo, M.C. 1995. Pastagens no ecossistema Cerrados: pesquisa para o desenvolvimento sustentavel. In: Proc. Simposio sobre Pastagens nos ecossistemas Brasileiros, Brasilia, DF. SBZ, Brasilia. pp. 28–62.
- Neufeldt, H., J.E da Silva, M. Ayarza and W. Zech. 1999. Phosphorus Fractions under different Land use Systems in Oxisols of the Brazilian Cerrados. pp. 146–157. In: *sustainable Manegment for the Oxisols of the Latin American savannas*. Eds R. Thomas and M. Ayarza. Centro Internacional de Agricultura tropical. Ciat publication no 312.
- NuMaSS 2003. Progress Report: Adoption of the nutrient management support system (NuMaSS) software throughout Latin America. Soil Management Collaborative Research Support Program, Soil Science Dept., N.C. State Univ., Raleigh, NC. 35 p.
- Oberson, A., Friesen, D.K., Rao, I.M., Bühler, S., and Frossard, E. 2001. Phosphorus transformations in an oxisol under contrasting land-use systems: The role of the soil microbial biomass. *Plant and Soil*, 237, 197–210.
- Phiri, S., Barrios, E., Rao, I.M., and Singh, B.R. 2001. Changes in soil organic matter and phosphorus fractions under planted fallows

- and a crop rotation on a Colombian volcanic-ash soil. *Plant and Soil*, 231, 211–223.
- Phiri, S., Amezcuita, E., Rao, I. M. and Singh, B. R. 2003. Constructing an arable layer through chisel tillage and crop-pasture rotations in tropical savanna soils of the Llanos of Colombia. *Journal of Sustainable Agriculture*. 23(1): 6–29.
- Rao, I.M. 1998. Root distribution and production in native and introduced pastures in the South American savannas. In Proc. 5th Symposium of the International Society of Root Research, "Root demographics and their efficiencies in sustainable agriculture, grasslands and forest ecosystems", pp.19–41. James E. Box, Jr (ed). Kluwer Academic Publishers, Netherlands.
- Rao, I.M. 2001. Adapting tropical forages to low-fertility soils. In: J.A. Gomide, W. R. S. Mattos and S. C. da Silva (Eds.) *Proceedings of the XIX International Grassland Congress*. Brazilian Society of Animal Husbandry, Piracicaba, Brazil. pp. 247–254.
- Rao, I.M., M. Ayarza and R.J. Thomas. 1994. The use of carbon isotope ratios to evaluate legume contribution to soil enhancement in tropical pastures. *Plant and Soil* 162: 177–182.
- Rao, I.M., Borrero, V., Ricaurte, J., Garcia, R., and Ayarza, M.A. 1997. Adaptive attributes of tropical forage species to acid soils III. Differences in phosphorus acquisition and utilization as influenced by varying phosphorus supply and soil type. *Journal of Plant Nutrition*, 20, 155–180.
- Rao, I.M., Borrero, V., Ricaurte, J., and Garcia, R. 1999. Adaptive attributes of tropical forage species to acid soils. V. Differences in phosphorus acquisition from inorganic and organic phosphorus sources. *Journal of Plant Nutrition*, 22, 1175–1196
- Rieber, C. 2004. Potential and constraints of Cowpea (*vigna unguiculata*) in Honduran Hillsides. Master Thesis. University of Hohenheim, Germany.
- Rivas, L., P. Hoyos, E. Amézquita and D.L. Molina. 2004. Manejo y uso de los suelos de la altillanura Colombiana. Análisis económico de una estrategia para su conservación y mejoramiento: Construcción de la capa arable. Proyecto de Evaluación de impacto. Centro Internacional de Agricultura Tropical. Convenio MADR-CIAT. 44 p.
- Rondón, M. DUXbury, J. Thomas, R. 2002. Effects of land use change in the Llanos of Colombia on Fluxes of methane and nitrous oxide and on radiative forcing of the atmosphere. In: *Confronting global climate change*. Annual report of the climate change project of CIAT. Cali, Colombia, p. 45–68.
- Rondón, M.A., Acevedo, D., Hernandez, R.M., Rubiano, Y., Rivera, M., Amezcuita, E., Romero, M., Sarmiento, L., Ayarza, M., Barrios, E. and Rao, I. 2004. Carbon Sequestration Potential of the Neotropical Savannas (Llanos) of Colombia and Venezuela. In: R. Lal and J. Kimble (eds) *Carbon sequestration potential of the main biomes of Latin America*. CRP Press. In review.
- Rubiano, Y. 2005. Sistema georreferenciado de indicadores de calidad del suelo GEOSOL. Herramienta SIG para apoyo a la toma de decisiones en planificación, uso y manejo del suelo. Estudio de caso Municipio de Puerto López, Meta. Thesis PhD. Facultad de Ciencias Agropecuarias, Enfoque Manejo de Suelos y Aguas. Universidad Nacional de Colombia, Sede Palmira. 128 p.
- Sanz, J.I., R.S. Zeigler, S. Sarkarung, D.L. Molina and M. Rivera. 2004. Improved Rice/pasture Systems for native savannas and degraded pastures in acid Soils of Latin America. pp. 240–252 In: *Agropastoral Systems for the Tropical Savannas of Latin America*. Editors. E.P. Guimaraes, J.I. Sanz, I.M. Rao, M.C. Amezcuita, E. Amézquita, R. Thomas. Cali, Colombia. Centro Internacional de Agricultura Tropical (CIAT): Empresa Brasileira de Pesquisa Agropecuaria (Embrapa). 342 p.
- Scherr, S.J. 2000. Hillsides research in the CGIAR: towards an Impact assessment. Report for the Special Program on Impact Assessment (SPIA) of the Technical Advisory Committee (TAC) of the Consultative Group for International agriculture (CGIAR), 63 pp. draft.
- Smith, J., J.V. Cadavid, M. Ayarza, J.L. Pimienta de Aguiar and R. Rosa. 1999. Land use Change in soybean production systems in the Brazilian savanna: the role of policy and market conditions. *Journal of Sustainable Agriculture*. Vol 15(2/3)
- Spain J.M, M. A. Ayarza and L. Vilela. 1996. Crop pasture rotations in the Brazilian cerrados. In: Pereira R.C; Nasser L.C, eds. *Simposio sobre o Cerrado*, 8, 1996, Brasilia EMBRAPA-CPAC, Planaltina. DF, Brazil, p 39–45.
- Scherr, S.J. and O. Neidecker-Gonzales. 1997. Desarrollo sostenible en las laderas en Mesoamérica: Alcances y potenciales. In S. Scherr, B. Miranda, O. Neidecker-Gonzales, eds. *Investigación sobre políticas para el desarrollo sostenible en las laderas mesoamericanas*, San Salvador, E.S.: IICA-Holanda/LADERAS, pp. 33–83.
- Sylvester-Bradley, R., Mosquera, D and J.E. Mendez. 1988. Inhibition of nitrate accumulation in tropical grassland soils: effect of nitrogen fertilization and soil disturbance. *J. Soil. Sci.* 39: 407–416
- Thomas.R.J., M.J. Fisher, M. A. Ayarza and J.I. Sanz, 1995. The role of Forage Grasses and Legumes in Maintaining the Productivity of Acid Soil in Latin America. In *Soil Management Experimental basis for Sustainability and environmental quality*. Eds R. Lal and A. Stewart. *Advances in soil science*. Boca Ratón, Fla. S590.2.S88.
- Trujillo, W., E. Amézquita, M.J. Fisher and R. Lal. 1998. Soil organic carbon dynamics and land use in the Colombian savannas. In R. Lal, J. Kimble, R. Follett, B. Stewart (Eds) "Soil Processes and the Carbon Cycle". CRC press, New York: 267–280.
- Valencia, R. A and D. Leal. 2004. Genetic Alternatives for Production Systems in the Acid-Soil Savannas of the Colombian Orinoquia. P 128–139. In: *Agropastoral Systems for the Tropical Savannas of Latin America*. Editors. E.P. Guimaraes, J.I. Sanz, I.M. Rao, M.C. Amezcuita, E. Amezcuita, R. Thomas. Cali, Colombia. Centro Internacional de Agricultura Tropical (CIAT): Empresa Brasileira de Pesquisa Agropecuaria (Embrapa). 342 p.
- Velasquez E, Lavelle P, Barrios E, Joffre R and F. Reversat. 2005. Evaluating soil quality in tropical agroecosystems of Colombia using NIRS. *Soil Biology and Biochemistry* 37: 889–898.
- Vera R and C. Seré. 1985: *Sistemas de producción pecuaria extensiva: Brazil, Colombia, Venezuela*. Informe Final del proyecto ETES (estudio Técnico y económico de Producción pecuaria). Centro Intenacional de Agricultura tropical (CIAT), Cali, Colombia 538 p.
- Westerhof, R., L. Vilela, M. Ayarza and W. Zech. 1998. Land use effects on labile N extracted with permanganate and the nitrogen management index in the Cerrado region of Brazil. *Biology and Fertility Soil*. 27:353–357. Springer-Verlag.
- Zhiping, Q., Rao, I.M., Ricaurte, J., Amézquita, E., Sanz, J., and Kerridge, P. 2003. Root distribution and nutrient uptake in crop-forage systems on Andean hillsides. *Journal of Sustainable Agriculture* (in press).

Integrating legumes to improve N cycling on smallholder farms in sub-humid Zimbabwe: resource quality, biophysical and environmental limitations

Regis Chikowo^{1,2,*}, Paul Mapfumo¹, Peter A. Leffelaar² and Ken E. Giller²

¹Department of Soil Science and Agricultural Engineering, University of Zimbabwe, Box MP 167, Mount Pleasant, Harare, Zimbabwe; ²Plant Production Systems, Department of Plant Sciences, Wageningen University, 6700 AK, Box 430, Wageningen, The Netherlands; *Author for correspondence (e-mail: Regis.Chikowo@cirad.fr; fax: (33) 467615512)

Key words: *Acacia angustissima*, Leaching, N mineralization, Nitrous oxide, Polyphenols, Residue quality, *Sesbania sesban*

Abstract

The release of mineral-N in soil from plant residues is regulated by their ‘quality’ or chemical composition. Legume materials used by farmers in southern Africa are often in the form of litter with N concentration <2%. We investigated the decomposition of *Sesbania sesban* and *Acacia angustissima* litter in the field using litterbags, and N mineralization of a range of legume materials using a leaching tube incubation method in the laboratory. The mass loss of the litter could be described using a modified exponential decay model: $Y = (Y_0 - Q)e^{-kt} + Q$. The relative decomposition constants for *Sesbania* and *Acacia* litter were 0.053 and 0.039 d⁻¹, respectively. The % N mineralized from fresh *Sesbania* prunings was 55% compared with only 27% for the *Sesbania* litter after 120 days of incubation under leaching conditions. During the same period, fresh prunings of *Acacia* released only 12% of the added N while *Acacia* litter released 9%. Despite the large differences in N concentration between *Acacia* prunings and its litter, the total mineralized N was similar, as mineralization from prunings was depressed by the highly active polyphenols. While N supply may be poor, these slow decomposing litter materials are potentially useful for maintaining soil organic matter in smallholder farms. In two field experiments with contrasting soil texture, *Sesbania*, *Acacia* and *Cajanus* produced large amounts of biomass (>5 Mg ha⁻¹) and improved N cycling significantly (>150 kg N ha⁻¹) on the clay loam soil, but adapted poorly on the sandier soil. There was a rapid N accumulation in the topsoil at the beginning of the rains in plots where large amounts of *Sesbania* or *Acacia* biomass had been incorporated. Despite the wide differences in resource quality between these two, there was virtually no difference in N availability in the field as this was, among other factors, confounded by the quantity of N added. A substantial amount of the nitrate was leached to greater than 0.4 m depth within a three-week period. Also, the incidence of pests in the first season, and drought in the second season resulted in poor nitrogen use efficiency. Our measurements of gaseous N losses in the field confirmed that N₂O emissions were <0.5 kg N ha⁻¹. As we had measurements of all major N flows, we were able to construct overall N budgets for the improved fallow – maize rotation systems. These budgets indicated that, in a normal rainfall season with no major pest problems, reducing nitrate leaching would be the single largest challenge to increased N recovery of added organic N in the light textured soils.

This article has been previously published in the journal “Nutrient Cycling in Agroecosystems” Volume 76 Issues 2–3.

Introduction

Incorporation of plant residues in agricultural soils is a useful means to sustain soil organic matter content, and thereby enhance the biological activity, improve physical properties and increase nutrient availability (Kumar and Goh 2000; Palm et al. 2001b). Legume remains and animal manures form a potentially important source of nutrients for crop production in smallholder agriculture in sub-Saharan Africa. The potential of these resources to contribute nutrients, especially N, for other crops is highly dependent on their N release characteristics with respect to demand for uptake by the crops. Decomposition and N release from organic materials in the soil is influenced by several biotic and abiotic factors including the quality of residues (Swift et al. 1979; Cadisch and Giller 1997). High quality materials (high N content, low lignin and polyphenols) are known to decompose quickly and could substitute mineral fertilizers in supplying N for annual crops (Mafongoya et al. 1998). However, the quantity of high quality legume materials on most smallholder farms is pitifully small.

Grain legumes are grown on very small portions of the land on smallholder farms, and though N_2 -fixation rates can be high, overall farm N inputs from biological N_2 -fixation are in some cases as low as $5 \text{ kg farm}^{-1} \text{ year}^{-1}$ as the area planted to legumes is often small (Giller 2001; Mapfumo et al. 2001). It therefore follows that systematic legume-cereal rotations are not feasible because of the disproportionately mismatching areas under the cropping of legumes and cereals. Most farmers grow maize and average crop residue carbon production is often less than $2 \text{ Mg ha}^{-1} \text{ year}^{-1}$. With the exception of the crop roots, a substantial part of these crop residues are eaten by animals and are returned to the fields as manure. As the food chain gets longer, leakages are bound to increase and the overall efficiency of the system is compromised. Under the current system, actual N and C additions on the farms are therefore variable and difficult to quantify, although in general additions are small and fertility of many cultivated fields is declining as evidenced by declining crop productivity (Smaling et al. 1997). In the absence of substantial native soil organic matter, organic fertility management must be

based on adequate repeated residue inputs that balance losses through mineralization and erosion.

Determination of N release from plant residues is often included in decomposition studies. Much research has focused on indicators of chemical quality (N concentrations, C:N ratios, lignin and polyphenol concentrations and computed ratios for the various combinations) as possible predictors for N mineralization or immobilization (Palm and Sanchez 1991; Constantinides and Fownes 1994; Handayanto et al. 1997). There are, however, varied reports in the literature on the relative importance of each of these residue quality parameters. A decision tree, which uses critical values of the different resource quality parameters to quantitatively define high and poor quality organic materials as they relate to their capacity to supply N for crop growth, was developed by Palm et al. (1997; 2001a). Due to retranslocation of nutrients, senesced leaves or litter have lower N and higher C:N ratios, are more lignified and may show decreased mineralization rates compared with the fresh material. Fresh legume prunings (leaves and twigs) are most widely studied for decomposition patterns (e.g. Mafongoya et al. 1998), and relatively little attention has been paid to N mineralization by the litter component.

This paper discusses the capacity of various legumes to cycle N and benefit rotational maize under the different edaphic conditions. The other objective was to investigate decomposition of litter materials in a litterbag experiment, and also to investigate N mineralization of both fresh prunings and litter of the various legume species in a leaching tube incubation experiment. Further, after presenting results of both N mineralization under controlled conditions and data on mineral N profiles in the field with *Sesbania sesban* and *Acacia angustissima*, we show why extrapolation of results from laboratory conditions to the field with improved fallows will remain elusive, as residue quality alone fails to fully account for many of the results from field experiments. Finally, as we had estimated all the major flows of N, we are able to construct detailed N budgets for a case study of an improved fallow-maize rotation system with both *Sesbania* and *Acacia*, compared with continuous maize cultivation.

Materials and methods

Quantifying nitrate leaching and N₂O emissions after improved fallows

Two field experiments were conducted at two sites with different soil texture: The first one was located at the field station of the International Centre for Research in Agroforestry (ICRAF) located at Domboshawa, Zimbabwe (17°35' S latitude, 31°14' E longitude). The soil is a sandy clay loam with 22% clay content, and classified as a Lixisol (World Reference Base for Soil Resources). Two successive maize crops were planted in plots after harvesting two-year old legume improved fallows of (i) *Sesbania sesban*, (ii) *Acacia angustissima*, (iii) *Cajanus cajan*. The fourth treatment was continuous maize without any fertilization. These treatments, on plot sizes of 12 m × 8 m, were replicated three times in a randomized complete block design. After cutting the legumes, all woody plant materials (>5 mm diameter) were removed from the plots for firewood, whereas twigs (<5 mm diameter), leaves and litter were left in the plots for incorporation.

Soils were sampled using augers in sections of 0–20, 20–40, 40–60, 60–90 and 90–120 cm to determine nitrate N dynamics during the cropping phase in all treatments, except *Cajanus*. In each plot soil was collected and bulked from two locations at each sampling time. Subsamples were taken to the laboratory in polythene bags and stored at 4 °C prior to extraction usually within two days of collection. The NO₂-N cadmium reduction method (Keeney and Nelson 1982) was used for soil nitrate-N determination. The quantity of nitrate leached was estimated as the cumulative decrease in the nitrate content of the soil profile between successive sampling events, early in the season when N uptake by maize was still insignificant. The closed soil chamber technique as described by Mathias et al. (1980) was used to estimate gaseous N losses as nitrous oxide in the field. In short, the method involved deploying PVC rings in the field a day before actual measurements were done. On the following day chamber lids were placed on the rings and sealed. Accumulated headspace was then sampled using a syringe at 0, 30 and 60 min after enclosing the

chambers. The gas samples were then analyzed by electron capture gas chromatography.

The second experiment was at a site where the soil was a highly leached coarse-grained sand derived from granite, with no more than 5% clay content to at least 1.2 m depth (Arenosol, FAO classification). The experiment involved a comparison of a range of legumes that included soyabean (*Glycine max*), mucuna (*Mucuna pruriens*), *Crotalaria paulina*, and the agroforestry species as described for the Domboshawa site. This experiment is described in detail by Chikowo et al. (2004a). In both experiments the % N derived from biological N₂-fixation was determined in the legume shoots using the ¹⁵N-natural abundance method (Peoples et al. 1989).

Litter decomposition in litterbags

To further our understanding of the behavior of the organic materials generated, the rate of mass loss of *Sesbania* and *Acacia* litter were assessed by placing 30 g dry weight litter into 25 × 25 cm litterbags with 2 mm mesh size. A total of 21 litterbags were used for each litter type. Seven litterbags of each type were placed in each of the three blocks and the litterbags were buried in the unfertilized maize plots to a depth of 0.15 m. This is the tillage depth normally achieved by farmers using ox-drawn ploughs hence litter is incorporated to this maximum depth. The placement of litterbags was done at the time of establishing the maize crop in the field at Domboshawa. Twigs of varying diameters ranging up to 5 mm constituted approximately 25% of the litter used. Initial chemical properties of these litters are shown in Table 1. One litterbag was retrieved from each block at 1, 3, 5, 8, 12, 17 and 21 weeks after burying, for each of the litter types. At each retrieval time, residues recovered from the litterbags were placed on a 0.5 mm sieve and soil adhering to the litter was carefully cleaned off in a bucket of water. Dry weight was recorded after oven drying at 65 °C for 48 h. Ash-free dry weight of recovered litter retrieved from the soil was obtained following combustion of the litter in a muffle furnace at 550 °C for 3 h. A modified exponential decay model was then fitted to the mass loss data.

Table 1. Chemical composition of legume fresh prunings and senesced litter used in the experiments.

Plant material	% N	% P	% lignin	% polyphenols	PBC	C:N ratio	Lignin:N
Sesbania leaves	3.2	0.28	4.5	1.9	28	14	1.4
Sesbania litter	1.6	0.21	5.4	0.8	20	21	3.4
Acacia leaves	4.8	0.57	7.1	5.7	160	10	1.5
Acacia litter	1.5	0.17	24.4	1.3	29	24	16.2
Soyabean stover	1.7	0.20	12.9	0.6	18	25	7.6
Mucuna litter	1.8	0.31	11.5	3.4	52	24	6.4

‰: (mg per mg dry weight) \times 100; PBC: protein binding capacity, μg BSA mg^{-1} plant sample (BSA = bovine serum albumin).

N mineralization in leaching tube incubations

Decomposition and N mineralization of different legume litters and two fresh prunings were determined in leaching tube incubations (Stanford and Smith 1972). Leaching tube incubations take into account the initial rapid loss of organic and mineral constituents during decomposition and allow periodic leaching from the same tube over time (Sakala et al. 2000). The treatments were fresh prunings of *Sesbania* and *Acacia*, and senesced litter of *Sesbania*, *Acacia*, soyabean, mucuna, and an unamended soil as the control. The soil was a granitic derived sandy soil from a smallholder farm with 4% clay content. To determine total plant N and P, samples of the materials were oven dried at 30–35 °C and ground to pass through a 1 mm sieve. Total N and P were analyzed through complete oxidation by Kjeldahl digestion using sulphuric acid, hydrogen peroxide and selenium digestion mixture (Anderson and Ingram 1993). All the residues were then added at a rate equivalent to 100 mg N of residues kg^{-1} soil.

The leaching tubes were made of plexiglass tubing, and were 28 cm long with an internal diameter of 40 mm. At the base of the tube was a rubber stopper with an opening at the centre where a glass tube was inserted to drain water during leaching. The immediate top of the rubber stopper was covered with rock-wool filter and then a layer of fine sand. After completion of setting up of the experiment tubes were immediately leached with 100 ml of leaching solution (1 mM CaCl_2 ; 1 mM MgSO_4 ; 0.1 mM KH_2PO_4 and 0.9 mM KCl) in 50 ml aliquots (Cassman and Munns 1980). Excess water was removed with a mild suction pump, and then the tubes were incubated in the dark at 24–25 °C.

The tubes were further leached on days 4, 8, 16, 32, 48, 64, 90 and 120. After each leaching, mild

suction was applied to drain excess leaching solution. The leachates were analyzed for $\text{NH}_4\text{-N}$ and $\text{NO}_3\text{-N}$. Net N-mineralization was calculated by subtracting N released from the unamended soil from that released by the residue-amended treatments. Nitrogen mineralization from the plant residues as a function of time (Nmin_t) was calculated from the difference in cumulative amounts of mineral N between soil treated with plant materials and the control at each sampling time divided by the total residue N added.

$$\text{Nmin}_t = \frac{\text{Min N (treat)}_t - \text{Min N (control)}}{\text{Total residue N added}}$$

All the materials used were also analyzed for their lignin and polyphenols contents, as well as the protein binding capacity of the polyphenols. Lignin was determined through acid detergent fibre. Total soluble polyphenols were determined by the Folin-Ciocalteu method (Constantinides and Fownes 1994). This involved extraction of 0.1 g material with 50% methanol in a flask that was placed in a water bath at a temperature of 77–80 °C for 1 h. Protein binding capacity of polyphenols was determined by extracting the material using 50% aqueous methanol at 95 °C. The extract was centrifuged and applied to chromatographic paper, followed by a reaction with bovine serum albumin.

Results and discussion

Biological N_2 -fixation rates and legume productivity

Estimates of biological N_2 -fixation on two field experiments with different texture showed that legumes fixed a large proportion of their accumulated N on both sites, but the actual amounts of the fixed N were very different (Table 2). As

Table 2. Biomass production, biological N₂-fixation, and N input through litter and stover from selected legumes grown on a sandy soil and clay loam soil in Zimbabwe (adapted from Chikowo et al., 2004a, b).

Legume	Leaves/litter (Mg ha ⁻¹)	Recyclable N ^a (kg ha ⁻¹)	% N from N ₂ -fixation	Net N input ^b (kg ha ⁻¹)
Sandy soil				
Soyabean	1.7 (0.11)	28 (2.2)	76	24
<i>Mucuna pruriens</i>	3.9 (0.20)	87 (3.7)	96	106
<i>Crotalaria paulina</i>	0.2	4	46	2
<i>Cajanus cajan</i>	0.4	7	65	4
<i>Sesbania sesban</i>	nd ^c	nd	84	nd
<i>Acacia angustissima</i>	nd	nd	79	nd
Sandy clay loam				
Cowpea	2.5 (0.18)	48(3.6)	58	30
<i>Cajanus cajan</i>	5.3 (0.23)	115 (4.6)	84	103
<i>Sesbania sesban</i>	5.7 (0.30)	152 (5.7)	55	67
<i>Acacia angustissima</i>	9.9 (0.58)	218 (11.6)	56	129

^a Above-ground plant accumulated N (Soil N + N₂-fixed N) returned to the soil in the form of litter and leaves.

^b Amount of N₂-fixed and returned to soil (above ground non-woody components + all root N) – soil derived N exported (woody parts and grain).

^c nd = not determined as these legumes grew poorly on the sandy soil site. values in parenthesis are standard error of means (SEMs).

estimated by the ¹⁵N natural abundance method, all the legumes, except *C. paulina*, derived at least 55% of their N from biological N₂-fixation across the sites. On the sandy site, although N₂-fixation rates were high for these woody legume species, total N fixed was small as these legumes grew poorly and produced little biomass. Soyabean responded well to inoculation with rhizobia and P fertilizer, and cycled comparatively larger quantities of N through its litter and stover when compared with the other legumes (Table 2). Net N input was, however, poor, as soil N was exported through seed harvest. As expected, mucuna had the greatest net N input of 106 kg ha⁻¹ into the system as no N was exported from the field through seed harvest. On the sandy clay loam soil *Sesbania*, *Cajanus* and *Acacia* had comparatively larger net N inputs compared to the same species on the sandy soil due to large biomass accumulated on the soil with less biophysical limitations (Table 2).

Sesbania sesban, *Cajanus cajan*, *Acacia angustissima* are legume species that have resulted in high subsequent maize yields (Mafongoya and Dzewela 1999). *Acacia* is expected to be especially efficient in recycling nutrients as its regrowth capabilities after fallow clearance means that it can be pruned regularly during maize cropping, and the prunings are spread in the field where they act as green manure or mulch. Herbaceous green manure legumes like mucuna grown specifically for soil fertility restoration have not been widely adopted

by farmers in southern Africa (Snapp et al. 1998). The lack of a direct usable product, such as food or fodder, is the principal disincentive that prevents farmers from readily adopting green manuring. Grain legumes have been grown by smallholder farmers in rotations with cereal crops and these can contribute N, but the contributions are variable (from -47 to 137 kg N ha⁻¹) depending on legume type, N partitioning characteristics and rate of biological N₂-fixation (Giller 2001). The benefit of grain legumes to soil fertility largely depend on how their residues are utilized, and grain legumes with large N harvest indices invariably contribute little N to the soil.

Mass loss by litter

The mass loss for both *Sesbania* and *Acacia* litter was rapid during the first 8 weeks after the litterbags had been buried in the soil (Figure 1). When the remaining organic material was plotted logarithmically against time, the resulting lines were non-linear indicating a poor fit to simple first order kinetics ($Y = Y_0 e^{-kt}$). Data were then fitted to a modified single exponential decay model: $Y = (Y_0 - Q) e^{-kt} + Q$, which gave a linear relationship for the plot of $\ln \{(Y - Q)/(Y_0 - Q)\}$ vs. time. 'Q' is the 'quantity' of litter that would remain undecomposed in the litterbags in the long run, and k is the relative decomposition rate. The proportions of recalcitrant material were found to

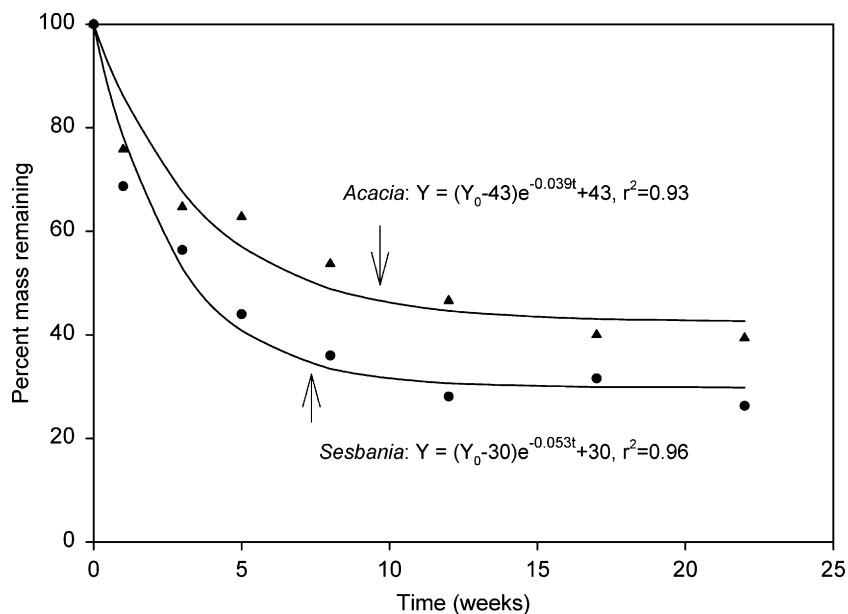

Figure 1. *Acacia* and *Sesbania* litter remaining in litterbags buried in soil on several retrieval times over a 22-week period under sub-humid conditions in the field at Domboshawa, Zimbabwe (see text for explanation of the regression functions).

be 30 and 43% for *Sesbania* and *Acacia*, respectively. The relative decomposition constants for *Sesbania* and *Acacia* litters were estimated to be 0.053 and 0.039 d⁻¹, respectively. These decomposition constants do not have a decomposition meaning solely since some mass loss may be due to material movement through the mesh, as evidenced by the darkened soil on the spots where litterbags had been removed.

At five weeks, about 60% of the *Sesbania* litter had been lost compared with only 40% for *Acacia* litter (Figure 1). The slower mass loss of *Acacia* litter as compared to *Sesbania* litter was probably linked to its higher lignin content (Table 1). About 25% of the litter we used was in the form of small twigs of up to 5 mm diameter, and such material is the more lignified component of the litter that takes longer to decompose or physically be removed from the litterbags with 2 mm mesh size.

Nitrogen mineralization patterns

The chemical composition of the materials used in the N mineralization study varied widely (Table 1). Except for *Acacia* litter, all the materials had lignin concentrations <15%. Total N was

less than 2% for all senesced materials, indicating large variations between fresh and litter materials from the same species. The % N mineralized from high quality *Sesbania* prunings was 55% compared with 27% for the *Sesbania* litter after 120 days of incubation under leaching conditions (Figure 2). During the same period, fresh prunings of *Acacia* released only 12% while its litter released 9% of the added N. Despite the large differences in total N concentration of the *Acacia* prunings and litter, the total mineralized N at the end of the incubation period was similar. The small proportion of N mineralized from the *Acacia* prunings was associated with the high activity of the polyphenols as indicated by the large protein binding capacity (Table 1). Palm and Sanchez (1991) attributed the differences in N release from prunings of various tropical legumes to the presence of polyphenols, and showed that the polyphenol:N ratio was a good predictor of N mineralization. Reactive polyphenols (condensed tannins) bind strongly to proteins in the residues and form complexes that are resistant to microbial attack (Handayanto et al. 1997). The larger polyphenol content and protein-binding capacity of mucuna litter compared with soyabean litter could partly explain why it immobilized N throughout the incubation period in our study.

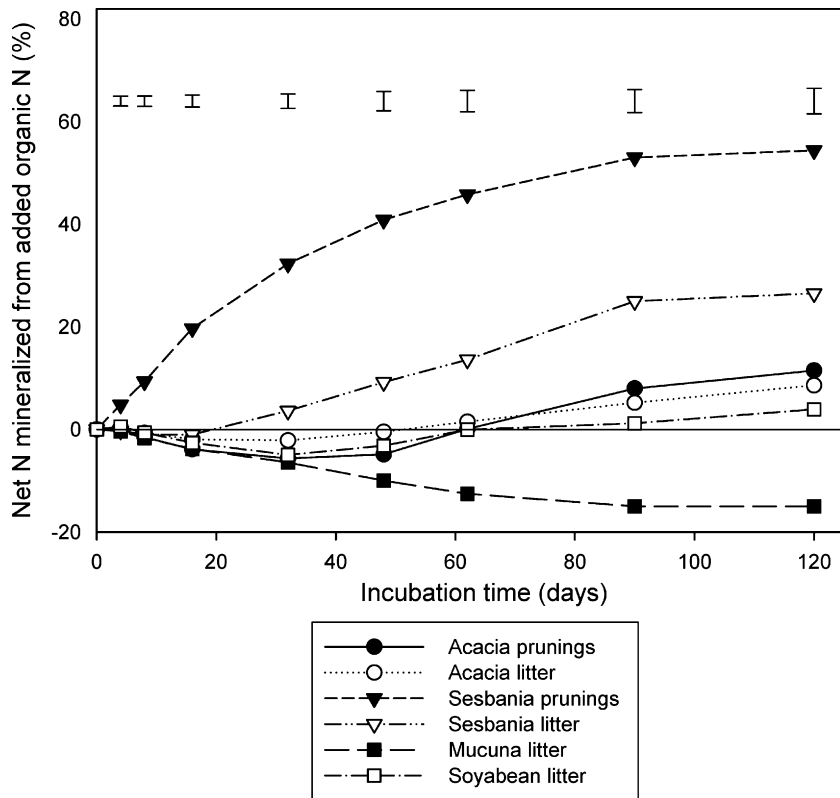

Figure 2. N release by various legume materials in a leaching tube incubation experiment. Bars represent least significant differences.

Net N mineralization from the fresh *Sesbania* prunings was more rapid and resulted in a greater proportion of the N released after 120 days than that from *Sesbania* litter. By contrast there were no obvious differences in N mineralization between prunings or litter of *Acacia*. Most of the senesced litter materials showed N immobilization up to 60 days of incubation, and then slight net mineralization. *Sesbania* litter immobilized N for a 2-week period only and then mineralized N slowly over the next 90 days. Much of the high energy soluble carbon compounds that support microbial activity are translocated from leaves during senescence, prior to abscission and leaf fall, and litter becomes more lignified (Constantinides and Fownes 1994). In a review of decomposition and N release patterns of tree prunings and litter, Mafongoya et al. (1998) showed that litter materials had lower nutrient concentrations compared with green foliage of the same legume species, and this was correlated with slower decomposition rates.

Nitrate leaching and N_2O emissions after the different legumes

Nitrate-N increased substantially in the top 0–0.4 m depth at the beginning of the rains, from 3.2 to 34 kg N ha⁻¹ in *Sesbania*, and from 6.7 to 29 kg N ha⁻¹ in the *Acacia* plots during the period from pre-season sampling to week one (Figure 3). There were no treatment differences in nitrate concentration in soil layers below 0.4 m for the week one samples. These increases in nitrate concentration in topsoil were not sustained as concentrations decreased rapidly only three weeks after planting maize. The decrease in topsoil nitrate concentration was accompanied by a relative increase at depths below 0.4 m. *In situ* production of nitrate at lower depth is unlikely to account for these dramatic increases as the soil contained little organic matter at depths below 0.4 m.

Beyond the third week after planting, the bulk of the nitrate had moved to the 1.0–1.2 m layer or beyond. Poor N recovery following incorporation

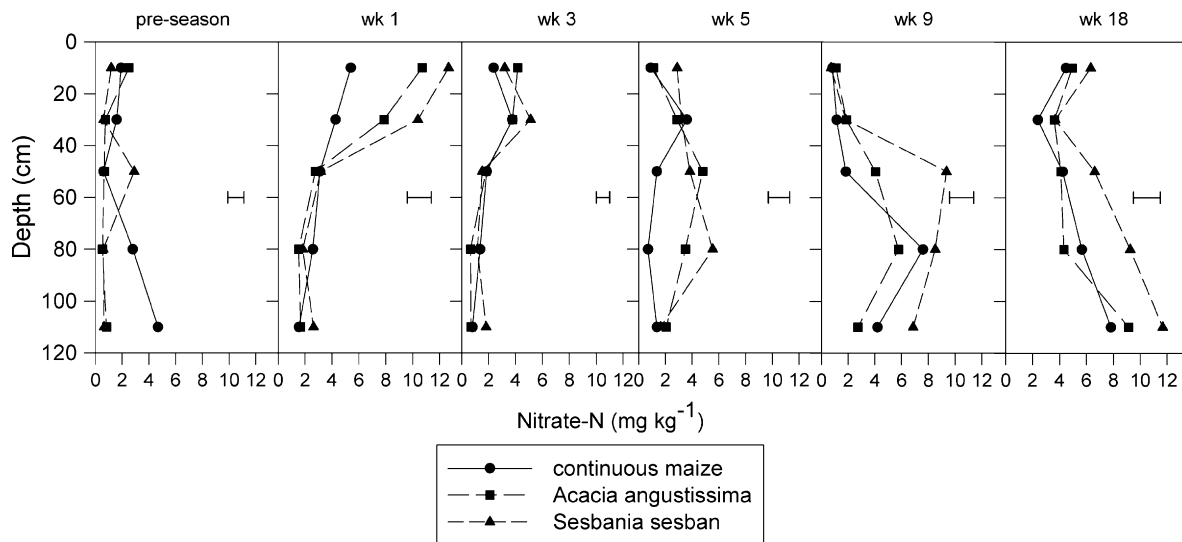

Figure 3. Nitrate-N dynamics following plots that had maize, and 2-year fallows of *Acacia* and *Sesbania*. Each error bar represents LSD ($P < 0.05$) for all depths for the respective sampling dates.

of high quality legume prunings such as *Sesbania* results due to rapid N release and subsequent leaching before crop root systems sufficiently develop (Figure 3). Despite the marked contrast in quality and N release patterns between both prunings and litter of *Sesbania* and *Acacia* in the laboratory incubations described above, this resulted in only slight differences in mineral N contents during the cropping season in the field. This is discussed further below. Using the mass balance approach on soil profile nitrate contents between successive sampling times, Chikowo et al. (2004c) estimated that up to 30 kg N ha^{-1} was leached from the top 0.4 m in the early weeks following planting of maize. None of the materials used in this study demonstrated a perfect synchrony of N release and plant uptake. Mineral N in topsoil following legume tree-improved fallows increases significantly at the start of the rains following a long dry season. Such temporary flushes in mineral N are not directly related to the quality of legume materials as described above, but probably other N sources such as turnover of microbial biomass and labile organic matter.

Nitrous oxide emissions following two-year improved fallows on a sandy clay loam soil indicated that legumes significantly increased N_2O emissions compared to unfertilized maize monoculture, but losses were $<0.5 \text{ kg ha}^{-1}$ for a measurement period of 56 days (Table 3). Under the less-reducing

Table 3. N_2O emissions in a field experiment that involved improved fallows on a sandy loam soil over a 56-day measurement period, Zimbabwe (from Chikowo et al. 2004c).

Treatment	Amount of N added (kg ha^{-1})	Total $\text{N}_2\text{O-N}$ emission (g ha^{-1})
Unfertilized maize	0	60 (12)
<i>Acacia angustissima</i>	218 (11.6)	180 (25)
<i>Sesbania sesban</i>	152 (5.7)	290 (38)
* <i>Sesbania sesban</i> -NT	152 (5.7)	240 (35)

SEM values for amount of N added and $\text{N}_2\text{O-N}$ emissions are given in parenthesis.

**Sesbania sesban*-NT = *Sesbania sesban* plots that were not tilled.

conditions of the open textured soils, a large proportion of the gaseous N could have been lost in the form of nitric oxide (NO). In a study of gaseous N emissions from savanna sandy soils, Scholes et al. (1997) reported that N_2O emissions averaged just 8% of the total N emissions. When denitrification losses were corrected using this factor, maximum amounts of N lost were still only 5 kg ha^{-1} . Though legumes result in increased N_2O emissions, the quantities lost are small and do not contribute significantly to the poor N recovery by crops under organic fertilization that is widely reported in literature (e.g. Mugwira and Mukurumbira 1986; Snapp et al. 1998; Chikowo et al. 2004c).

The nutrient release dilemma of the available organic materials

While nutrient quality explains and predicts N release under controlled conditions (Cadisch and Giller 1997; Handayanto et al. 1997), field environmental factors drive a substantial part of the realities that the farmers face. There are complex factors involved in the N transformations in soils once organic materials are incorporated, and quality parameters as well as the environment will dictate N release. Synchronization of N mineralization and crop demand will be difficult to achieve for many organic resources as either N release precedes plant demand or is too slow. For example, data for nitrate dynamics in the field under maize in sequence with improved fallows showed nitrate profiles of both *Acacia* and *Sesbania* moving well in advance of the crop demand (Figure 3). There was virtually no difference in N availability in *Acacia* or *Sesbania* plots in the field, despite the wide differences in quality that clearly explained the differences in N mineralization patterns in the controlled leaching tube incubation experiment described in section 3.3 above. Specifically, the rapid mineral N accumulation in *Acacia* plots after one week would seem to sharply contradict its N release characteristics as controlled by high lignin content for its litter and the high protein binding capacity of its polyphenols for the prunings. In the field the effects of litter quality and differing N mineralization patterns are confounded by differences in the quantity of N between treatments as well as the duration of exposure of the materials to the environment. In the case of an improved fallow system we report here, at the end of the two years of having the legumes in the plots, there is usually a mixture of plant materials that are at various stages of decomposition and the beginning of rains triggers immediate N mineralization. The resulting N release patterns are, thus, atypical of what would be expected from the chemical composition of the materials. Managing N release in the field under such conditions will remain elusive.

When fresh prunings are used, as in biomass transfer systems, the release of N is in most cases similar to that of litter that has been in the field for a long time. Materials such as *Acacia* prunings that have large amounts active polyphenol would decompose too slowly, again in asynchrony with plant uptake (Figure 2), although accumulated

decomposing litter from the two-year fallow supplies mineral N immediately. Slow decomposing legume materials have the additional advantage of building up and maintaining reasonable soil organic matter contents on sandy soils.

Of the non-legume organic materials, cattle manure is widely used by smallholder farmers as a soil amendment to sustain crop production (Mapfumo and Giller 2001). Cattle graze in large grasslands during the day and manure is collected overnight in cattle pens, thus effectively concentrating nutrients from the large pasture areas. The concentrated nutrients are, however, susceptible to losses (e.g. N loss through volatilization, leaching in pens) and the end product is manure usually mixed with substantial amounts of sand, and with low N and recalcitrant C. Mineralization characteristics of such manure are also not favourable to support high crop yields (Mugwira and Mukurumbira 1986).

Impact of an improved fallow system: a case study

Much is known concerning N supply by a wide range of organic resources and an organic resource database has been developed to aid systematic analysis of these inputs for tropical agriculture (Palm et al. 2001a). Despite the vast documentation of such knowledge, there is a growing challenge to increase crop productivity to levels adequate to sustain human populations in sub Saharan Africa. The resultant increased intensity of land use as populations grow, has led to increased nutrient depletion through crop removal and soil erosion.

Figure 4a summarizes N cycling in an improved fallow system of both *Sesbania* and *Acacia* as related to the specific seasons we carried out our experiment. The combined N uptake by the two maize crops following *Sesbania* fallows was 45 kg ha⁻¹. When the 22 kg N ha⁻¹ used by the unfertilized maize treatment in the two seasons is subtracted from this figure, the N from *Sesbania* prunings and litter recovered by the two subsequent maize crops can be estimated to be 23 kg, representing a N recovery rate of 15% N of that applied. In this experiment, growth of maize and N use efficiency were strongly depressed by cutworm infestation during the first season, and by drought during the second season (Chikowo et al.

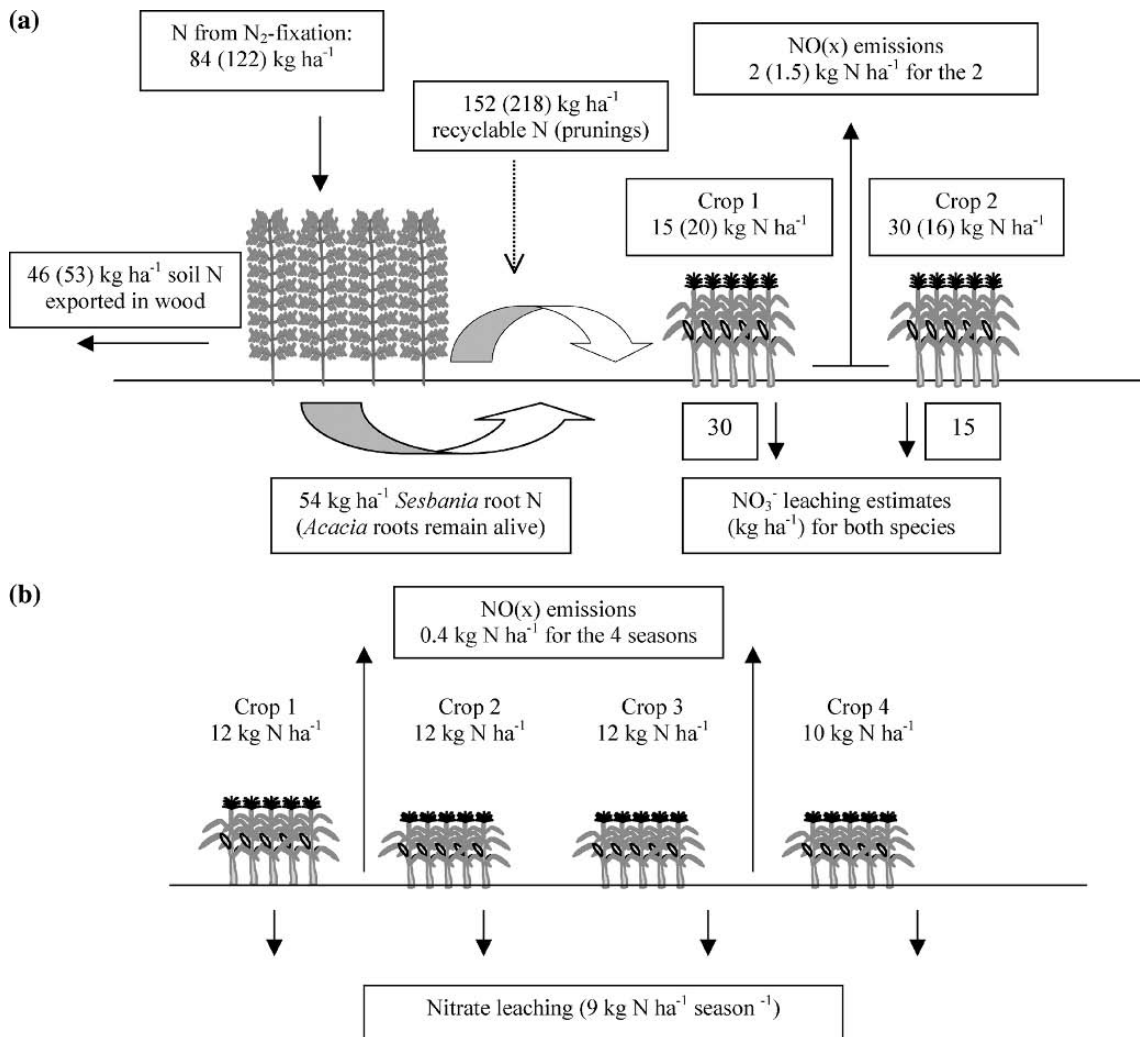

Figure 4. Nitrogen flows in (a) *Sesbania* (*Acacia*)-maize-maize cropping sequence and (b) maize monoculture with no fertilizer application. Figures in brackets for (a) are for *Acacia* N flows. It was assumed that N mineralization from SOM was equal in both cases at 30 kg N ha⁻¹ year⁻¹ (2% of native SOM).

2004b). A similar analysis with *Acacia* shows that of the total of 218 kg ha⁻¹ recycled N, about 122 kg was derived from N₂-fixation. Even after accounting for the soil-sourced N that was exported from the field in woody material (53 kg N ha⁻¹), there was still substantial net N input. *Acacia* root system contained substantially larger N amount than *Sesbania*, but unlike *Sesbania*, most of the roots remain alive after tree harvests as the species has regrowth capabilities. Thus, *Acacia* root N does not translate into an active N input until the trees are completely destroyed. We have already indicated earlier that

there were strikingly similar mineral N profiles early in the season, between *Sesbania* and *Acacia* plots, this despite the contrasting litter qualities. Differences in profile mineral N became significant later in the season, probably due to *Acacia* trees capturing some of the leached N from depth (Figure 3). As was for *Sesbania* plots, maize following *Acacia* was also affected by pests and drought in the first and second seasons, respectively. Improved N cycling was therefore not supported well via maize yields and N uptake in this study. An earlier experiment on the same field resulted in high maize yields following improved

fallows (Mafongoya and Dzowela, 1999; Table 4). The depressed yields of maize due to pest attack and drought demonstrates the high risks that farmers face as legume technologies are integrated into the farming system.

In continuous cropping systems with little external inputs in Africa, crop production is generally supported through native soil organic matter decomposition until the systems collapse due to soil organic matter reaching critically low concentrations or other soil physical limitations getting more prominent (Smaling et al. 1997). If the decomposition coefficient of SOM is assumed to be 2% (Swift et al. 1979), the soil with 0.06% organic N in the top 0.2 m layer releases about 30 kg N ha⁻¹ year⁻¹. Even with very high N use efficiency, this amount would only support modest crop yields (Figure 4b). With no substantial annual organic material additions (except from weeds), the native soil organic matter decreases and the capacity of soil to supply N gradually decreases, and so will the production intensity that can be supported. We have established that gaseous N emissions are small under unfertilized conditions, and we propose that a substantial proportion of the mineralized N from soil organic matter will be leached as unfertilized maize in a P deficient soil has a poor root system to absorb the N. Though soil losses due to erosion are higher under maize monoculture than following improved fallows, the eroded soil has poor nutrient content and total N losses are thus small.

While the N₂-fixation rate in the legumes is fairly consistent, crop growth and N accumulation are strongly influenced by variability in rainfall during the cropping seasons. It is expected that in the absence of pests and when rainfall is more

evenly distributed, N leaching losses will be smaller and N use efficiency will be larger. Losses of N through erosion will also depend on the rainfall intensity, and its partitioning into infiltration and runoff. N losses due to erosion are small during immediate cropping season after fallow termination, as infiltration rates are large. However, such losses markedly increase in subsequent cropping seasons as the physical effects of improved fallows on water infiltration dynamics disintegrate (Nyamadzawo et al. 2003).

Conclusions

Large proportions of the N accumulated by legumes came from N₂-fixation on both the sandy clay loam and the sandy soil. However, on the sandy site, these were large proportions of small amounts of N and overall N cycling was therefore poor. We have further confirmed that total N content is a poor index to use for N mineralization prediction in some legume prunings like *Acacia* that have highly active polyphenols. The slow release of N due to initial immobilization by a number of senesced legume materials we used means that crop fertilization with such materials alone will not support high productivity. Though N mineralization differences between *Sesbania* and *Acacia* were pronounced in the laboratory experiment, there was virtually no difference in N availability in *Acacia* or *Sesbania* plots in the field, despite the wide resource quality differences. Thus, there remains the challenge to integrate results from litterbag and leaching tube incubation studies to the prediction of N availability in the field. Senesced legume litter materials decompose

Table 4. Maize grain yields (Mg ha⁻¹) for two immediate seasons of cropping following 2-year improved fallows at the same site, Domboshawa, Zimbabwe.

Legume species	Phase 1 ^a		Phase 2 ^b	
	Season 1 1995	Season 2 1996	Season 1 2001	Season 2 2002
<i>Sesbania sesban</i>	4.9	3.7	0.67	1.30
<i>Acacia angustissima</i>	2.9	1.3	0.91	0.58
<i>Cajanus cajan</i>	3.4	3.0	1.20	1.11
Unfertilized maize	1.2	1.3	0.85	0.62
LSD (0.05)	0.4	0.5	0.18	0.14
Rainfall (mm)	672	715	1 218	461

^a Adapted from Mafongoya and Dzowela (1999).

^b Chikowo et al. 2004b.

slowly, thus, are potentially more useful for maintaining soil organic matter in smallholder farms than the rapidly decomposing fresh prunings. Our measurements of gaseous N losses in the field confirmed that N₂O emissions were small, while substantial amounts of nitrate were leached from the topsoil, driven by the high intensity rainfall and the asynchronous nature in the release of N and its demand by crops. In principle increased N cycling should be associated with increased crop productivity, but we have presented a case in which external biological and environmental factors may nullify the great potential of a promising legume-based farming system.

Acknowledgements

We thank ICRAF for facilitating this work at a long-term experiment at Domboshawa site in Zimbabwe. We are grateful to The Rockefeller Foundation and the EU through the IMPALA project, for financial support, and TSBF through AfNet for funding the first author to attend the AfNet Symposium in Yaounde, Cameroon.

References

- Anderson J.M. and Ingram J.J. 1993. *Tropical Soil Biology and Fertility (TSBF), A Handbook of Methods* (2nd ed.). CAB International, Wallingford, UK.
- Cadisch G. and Giller K.E. 1997. *Driven by Nature Plant Litter. Quality and Decomposition*. CAB International, Wallingford, UK.
- Cassman K.G. and Munns D.N. 1980. Nitrogen mineralization as affected by soil moisture, temperature and depth. *Soil Sci. Soc. Am. J.* 44: 1233–1237.
- Chikowo R., Mapfumo P., Nyamugafata P. and Giller K.E. 2004a. Maize productivity and mineral N dynamics following different soil fertility management technologies on a depleted sandy soil in Zimbabwe. *Agric. Ecosyst. Environ.* 102: 119–131.
- Chikowo R., Mapfumo P., Nyamugafata P. and Giller K.E. 2004b. Woody legume fallow productivity, biological N₂-fixation and residual benefits to two successive maize crops in Zimbabwe. *Plant Soil* 262: 303–315.
- Chikowo R., Mapfumo P., Nyamugafata P. and Giller K.E. 2004c. Mineral N dynamics, leaching and nitrous oxide losses under maize following two-year improved fallows on a sandy loam soil in Zimbabwe. *Plant Soil* 259: 315–330.
- Constantinides M. and Fownes J.H. 1994. Nitrogen mineralization from leaves and litter of tropical plants: relationship to nitrogen, lignin and soluble polyphenol concentrations. *Soil Biol. Biochem.* 26: 49–55.
- Giller K.E. 2001. *Nitrogen Fixation in Tropical Cropping Systems*. CAB International, Wallingford, UK.
- Handayanto E., Cadisch G. and Giller K.E. 1997. Nitrogen mineralization from mixtures of legume tree prunings of different quality and recovery of nitrogen by maize. *Soil Biol. Biochem.* 29: 1417–1426.
- Keeney D.R. and Nelson D.W. 1982. Nitrogen-inorganic forms. In: Page A.L., Miller R.H. and Keeney D.R. (eds), *Methods of Soil Analysis. Agronomy 9*, 2nd ed.. WI, ASA Madison, pp. 643–698.
- Kumar K. and Goh K.M. 2000. Crop residues and management practices: effects on soil quality, soil nitrogen dynamics, crop yield, and nitrogen recovery. *Adv. Agron.* 68: 197–319.
- Mafongoya P.L. and Dzwowela B.H. 1999. Biomass production of tree fallows and their residual effect on maize in Zimbabwe. *Agroforest. Syst.* 47: 139–151.
- Mafongoya P.L., Nair P.K.R. and Dzwowela B.H. 1998. Mineralization of nitrogen from decomposing leaves of multi-purpose trees as affected by their chemical composition. *Biol. Fert. Soils.* 27: 143–148.
- Mapfumo P. and Giller K.E. 2001. Soil fertility management practices by smallholder farmers in semi-arid areas of Zimbabwe. ICRAF/FAO, Hyderabad, India.
- Mapfumo P., Chikowo R. and Giller K.E. 2001. Closing the Loop: Identifying N sources and Minimizing N Losses in Leguminous Cropping Systems. Final Project Report of the Nitrogen Exploration Project to the Rockefeller Foundation. Harare, Zimbabwe.
- Matthias A.D., Blackmer A.M. and Bremner J.M. 1980. A simple chamber technique for field measurement of emissions of nitrous oxide from soils. *J. Environ. Qual.* 9: 251–256.
- Mugwira L.M. and Mukurumbira L.M. 1986. Nutrient supplying power of different groups of manure from the communal areas and commercial feedlots. *Zimb. Agric. J.* 83: 25–29.
- Nyamadzawo G., Nyamugafata P., Chikowo R. and Giller K.E. 2003. Partitioning of simulated rainfall in a kaolinitic soil under improved fallow-maize rotation in Zimbabwe. *Agroforest. Syst.* 59: 207–214.
- Palm C.A. and Sanchez P.A. 1991. Nitrogen release from the leaves of some tropical legumes as affected by their lignin and polyphenolic contents. *Soil Biol. Biochem.* 23: 83–88.
- Palm C.A., Myers R.J.K. and Nandwa S.M. 1997. Combined use of organic and inorganic nutrient sources for soil fertility maintenance and replenishment. In: Buresh R.J., Sanchez P.A. and Calhoun F. (eds), *Replenishing Soil Fertility in Africa. Spec. Publ. 51*. ASA, CSSA, SSSA, Madison, WI, pp. 193–217.
- Palm C.A., Gachengo C.N., Delve R.J., Cadisch G. and Giller K.E. 2001a. Organic inputs for soil fertility management in tropical agroecosystems: application of an organic resource database. *Agric. Ecosyst. Environ.* 83: 27–42.
- Palm C.A., Giller K.E., Mafongoya P.L. and Swift M.J. 2001b. Management of organic matter in the tropics: translating theory into practice. *Nutr. Cycl. Agroecosyst.* 61: 63–75.
- Peoples M.B., Faizah A.W., Rerkasem B. and Herridge D.H. 1989. *Methods of Evaluating Nitrogen Fixation by Nodulated Legumes in the Field*. Australian Centre for International Agricultural Research, Canberra.
- Sakala W.D., Cadisch G. and Giller K.E. 2000. Interactions between residues of maize and pigeonpea and mineral N

- fertilizers during decomposition and N mineralization. *Soil Biol. Biochem.* 32: 699–706.
- Scholes M.C., Martin R., Scholes R.J., Parsons D. and Winstead E. 1997. NO and N₂O emissions from savanna soils following the first simulated rains of the season. *Nutr. Cycl. Agroecosyst.* 48: 115–122.
- Smaling E.M.A., Nandwa S.M. and Janssen B.H. 1997. Soil fertility in Africa is at stake. In: Buresh R.J., Sanchez P.A. and Calhoun F. (eds), *Replenishing Soil Fertility in Africa*. ASA, CSSA, SSSA, Madison, WI, pp. 47–61.
- Snapp S.S., Mafongoya P.L. and Waddington S. 1998. Organic matter technologies for integrated nutrient management in smallholder cropping systems of southern Africa. *Agric. Ecosyst. Environ.* 71: 185–200.
- Stanford G. and Smith S.J. 1972. Nitrogen mineralization potentials of soils. *Soil Sci. Soc. Am. J.* 36: 465–472.
- Swift M.J., Heal O.W. and Anderson J.M. 1979. *Decomposition in Terrestrial Ecosystems*. Blackwell, Oxford, UK.

Meat and bone meal as nitrogen and phosphorus fertilizer to cereals and rye grass

Alhaji S. Jeng^{1,*}, Trond Knapp Haraldsen¹, Arne Grønland¹ and Per Anker Pedersen²
¹Norwegian Centre for Soil & Environmental Research, Frederik A. Dahls vei 20, N-1432 Ås, Norway;
²Department of Plant and Environmental Sciences, Norwegian University of Life Sciences, N-1432 Ås, Norway; *Author for correspondence (e-mail: alhaji.jeng@jordforsk.no; fax: +47-64948110)

Key words: Meat and bone meal, Nitrogen, Phosphorus, Residual effects

Abstract

Meat and bone meal (MBM) contains appreciable amounts of total nitrogen (~8%), phosphorus (~5%) and calcium (~10%). It may therefore be a useful fertilizer for various crops. This paper shows results from both pot and field experiments on the N and P effects of MBM. In two field experiments with spring wheat, increasing amounts of MBM (500, 1000, 2000 kg MBM ha⁻¹) showed a linear yield increase related to the N-supply. A similar experiment with barley gave positive yield increase for 500 kg MBM ha⁻¹ and no further yield increase for larger amounts of MBM. Supply of extra mineral P gave no yield increase when 500 kg MBM ha⁻¹ or more was applied. Meat and bone meal as P fertilizer was studied in greenhouse experiments using spring barley and rye grass as test crops. N applications were 100 N kg ha⁻¹ to barley and 200 kg N ha⁻¹ to rye grass, either from mineral fertilizer or assuming that 80% of total N in MBM was effective. Four different P deficient soils were given increasing doses of MBM and compared with compound NPK fertilizer 11-5-18, mineral N fertilizer (0 kg P ha⁻¹) and a control (0 kg N ha⁻¹, 0 kg P ha⁻¹). In barley there was no significant yield difference between the NPK treatment and MBM treatment with equal N supply, and both had significant higher yield than the treatment receiving the same amount of mineral N without P-supply. The positive yield response of MBM was even larger in rye grass. Both in barley and rye grass a significant residual effect of P from MBM applied the year before was found when the treatments received the same amount of mineral N fertilizer (0 kg P ha⁻¹). The pot experiments confirmed the assumed N effect of MBM. When MBM is used according to the N demand of the crops, the P supply will be more than sufficient and residual P will be left in the soil. Since a part of this residual P was utilized by the crops of the following year, it is not recommended to apply P-fertilizer the year after MBM application.

Introduction

Meat and bone meal (MBM) has been widely used as a valuable protein and mineral source in diets of production animals (Hendriks et al. 2002). Development of animal transmissible spongiform encephalopathies (TSE), like ovine scrapie and

bovine spongiform encephalopathy (BSE) has been linked to feeding ruminants with MBM contaminated with transmissible agents (Brewer 1999). Therefore the use of MBM for ruminants was banned in the European Union in 1994, and the use of MBM for all production animals was banned in 2000 in the European Union and most

This article has been previously published in the journal "Nutrient Cycling in Agroecosystems" Volume 76 Issues 2–3.

other European countries (Kamphues 2002). This situation has forced the meat production industry to look for alternative use of MBM.

Chemical analyses of MBM indicate that the material contains substantial amounts of organic matter, nitrogen, phosphorus and calcium. The material should therefore be interesting as a fertilizer.

The effectiveness of MBM as a nitrogen fertilizer to wheat has been evaluated by Salomonsson et al. (1994, 1995). They found better use of nitrogen from MBM than from pig slurry, and the N content of the fertilizer was as effective as urea-N. Meat and bone meal has been found to give sufficient nitrogen supply for good baking performance of organically grown wheat (Fredriksson et al. 1997, 1998). Mixing MBM to soil has been found to increase potato quality due to reduced incidence of potato scab (*Verticillium dahliae*) and decreased populations of parasitic nematodes (Lazarovits et al. 1999; Lazarovits 2001). Jeng et al. (2004) found that 80% of total N in MBM was effective compared to mineral N fertilizer.

The efficiency of added P depends, to a considerable extent, on the quantity of residual P in soils. When MBM is added as phosphate fertilizer, the labile pool of available P is increased and the capacity of soils to adsorb additional phosphate can be expected to decrease. The MBM-P is partly present as $\text{Ca}_5(\text{PO}_4)_3\text{OH}$ in the bone fraction and in organic form in the meat fraction. Kahiluoto and Vestberg (1998) found a significantly larger P uptake from bone meal than from Kola apatite in a pot experiment. Kola apatite did not influence soil acetate-extractable P contents, whereas bone meal increased the acetate-extractable P contents significantly. However, Baker et al. (1989) performed different laboratory tests of P-availability of bone meal (BM), and found considerable P-effect of bone meal in green house experiments. This indicates that bone meal is a better P source than the commonly used phosphate rock. As the dissolution of $\text{Ca}_5(\text{PO}_4)_3\text{OH}$ in the bones requires H^+ ions, pH is an important factor influencing P release from bone meal. Earlier investigations indicate that bone meal may be a more effective P fertilizer in acid soils than in soils with $\text{pH} > 6$ (Bekele and Hofner 1993; Surendra et al. 1993). Novelo et al. (1998) found that bone meal significantly

increased P-Olsen level and microbial biomass in coffee plantation soils. Compared with soluble mineral P fertilizers, MBM-P is expected to have a greater residual effect. Studies using a mixture of rock phosphate and poultry manure (Akande et al. 2005) have indicated that one time application was able to sustain four successive cropping of maize and cowpea. Meat and bone meal containing both organic and inorganic P-fractions may be expected to possess similar properties.

The objective of this investigation was to determine the effectiveness of MBM as a source of nitrogen and phosphorus for cereals and rye grass.

Materials and methods

Chemical analyses of meat and bone meal and soils

pH was determined potentiometrically, using a combined electrode and a reference electrode (NS 4720), in a suspension of MBM (soil) and water (1:3).

Material density, Loss on ignition (LOI) and dry matter (DM) content were determined gravimetrically.

Total contents of phosphorus (P), calcium (Ca) magnesium (Mg), and potassium (K) were determined by simultaneous ICP-AES, using a Perkin Elmer 3000DV, after aqua regia dissolution of the material.

Total Organic Carbon (TOC) was determined by combustion of a crushed sample at 925 °C using a Perkin Elmer 2400 CHN analyzer after sample treatment with 2 M HCl to remove any inorganic carbon.

Kjeldahl-nitrogen was determined by the Kjeldahl method (Bremner 1960). $\text{NH}_4\text{-N}$ and $\text{NO}_3\text{-N}$ were determined after extraction with 2 M KCl.

Readily available plant nutrient was determined by extraction with 0.1 M ammonium lactate and 0.4 M acetic acid buffered to pH 3.75 (AL-extractable) (Egnér et al. 1960), and analysed by ICP.

Experiments for evaluation of fertilizer effects of MBM

The effect of MBM as fertilizer was studied in green house and field experiments.

Field experiments

Three field experiments with combination of commercial fertilizer and MBM to cereals were carried out in 2003. The experiments were located to farmers' fields in the counties Rogaland, Østfold and Hedmark in Southern Norway. There was a split plot design with treatment A on large plots, and treatment B on small plots (Table 1), using two replicates. To ensure sufficient nitrogen supply after germination all plots received a base fertilizer of 30 kg N ha⁻¹ in calcium nitrate in spring. The field at Rogaland received 70 kg K ha⁻¹ as potassium chloride due knowledge about the climatic conditions with long periods with heavy rain during the growing season, increasing the risk for leaching of potassium. The soil in Østfold was clay loam soil of marine origin, which has large content of HNO₃ extractable K (K-HNO₃). The soil at the experimental field in Hedmark was on a sandy loam (till), where the local agricultural advisor found the K-status high enough to give satisfactory yield without supply of K. Spring wheat (*Triticum aestivum*) was grown in the experiments at Østfold and Hedmark, while spring barley (*Hordeum vulgare*) was grown at the experiment in Rogaland.

Pot experiments

The pot experiments were designed in order to study the effect of MBM as P-fertilizer. Based on previous experiments (Jeng et al. 2004) the N fertilization effect in the first growing season was estimated to be 80% of the total N in MBM. The intention was to apply sufficient amounts of N to ensure that N was not a limiting factor on plant growth while studying the P effect. The nutrient content of MBM from the field experiment carried out in 2002 was used for calculation of the amounts MBM to apply (Table 2). The intended N fertilization level for barley was 100 kg N ha⁻¹. For rye grass (*Lolium perenne*) the intended N

fertilization level was 200 kg N ha⁻¹. However, the MBM used in the experiment had higher N concentration and lower P concentration than the MBM used the previous season (Table 2), and this MBM had similar chemical characteristics as the mean values for the production in 2003 at the factory Norsk Protein, Hamar. Pots with effective volume of 3 l soil were used. In the pot experiments four soil types were used: Øksna sandy loam, Steinskogen sandy loam, Elverum medium sand, and Ås silt loam (Table 3). Before the experiment started in 2003 the soils from Steinskogen, Elverum and Ås were limed with dolomite (1 g l⁻¹). The liming gave pH above 6 for the soils from Elverum and Ås, while the pH in the Steinskogen soil was 5.2.

The experimental design for spring barley is shown in Table 4. A base fertilization of potassium and magnesium sulphate (25% K, 6% Mg, 17% S) equivalent to 80 kg K ha⁻¹ was applied to all pots. There were 4 replications. The experimental design for rye grass is shown in Table 5. A base fertilization of potassium and magnesium sulphate (25% K, 6% Mg, 17% S) equivalent to 200 kg K ha⁻¹ was applied to all pots. There were 4 replications.

In order to test the residual P effect of P-application in fertilizer and MBM, the pot experiments were repeated in 2004. In the spring barley experiment the treatments 2–8 received mineral N fertilizer (YARA OPTI-KAS), equivalent to 100 kg N ha⁻¹, while the control (treatment 1) was not fertilized with N. In the rye grass experiment the treatments 2–8 received mineral N fertilizer (YARA OPTI-KAS), equivalent to 200 kg N ha⁻¹, while the control (treatment 1) was unfertilized. The same base fertilization with potassium and magnesium sulphate was applied to the pot experiments as in the previous year. Because some of the soil in the pots had been sampled for soil analyses in autumn 2003, the pot

Table 1. Experimental design for field trials with MBM, Southern Norway (base fertilization 30 kg N ha⁻¹ in calcium nitrate).

Treatment A commercial fertilizer	Treatment B meat and bone meal	kg Kjeldahl N ha ⁻¹ in MBM	kg P ha ⁻¹ in MBM
1. Without fertilizer	1. Without MBM	0	0
2. 25 kg P ha ⁻¹ (P8)	2. 500 kg MBM ha ⁻¹	42.5	25
3. 30 kg N ha ⁻¹ calcium nitrate	3. 1000 kg MBM ha ⁻¹	85	51
4. 25 kg P ha ⁻¹ + 30 kg N ha ⁻¹	4. 2000 kg MBM ha ⁻¹	170	102

Table 2. Chemical characteristics of the MBM used in the experiments and mean values of MBM from Norsk Protein at Hamar in 2003.

Parameter, unit	MBM used in field experiment at Ås (mean of 4 samples)	MBM used in pot experiments	Mean of MBM analyses from Norsk Protein, Hamar
pH	6.5	6.6	–
DM, g (100 g) ⁻¹	97	97.8	96.2
Loss on ign., g (100 g) ⁻¹ DM	66.4	74.0	71.9
Tot. org. C, g (100 g) ⁻¹ DM	29.0	29.0	–
Tot. N, g (100 g) ⁻¹ DM	7.89	9.16	8.73
C/N ratio	3.68	3.17	–
NH ₄ -N, mg kg ⁻¹ DM	273	45.2	–
NO ₃ -N, mg kg ⁻¹ DM	0.57	0.4	–
Tot. P, g (100 g) ⁻¹ DM	5.58	4.66	4.78
P-AL, g (100 g) ⁻¹	2.23	1.55	–
N/P ratio	1.41	1.97	–
Tot. K, g (100 g) ⁻¹ DM	0.36	0.47	–
Tot. Ca, g (100 g) ⁻¹ DM	11.1	8.37	8.70
Tot. Mg, g (100 g) ⁻¹ DM	0.21	0.20	–

Table 3. Chemical analyses of the soils used in the pot experiments (after liming and before fertilizer application).

Parameter	Unit	Øksna	Steinskogen	Elverum	Ås
pH		6.7	5.2	6.6	6.2
Org. C	g (100 g) ⁻¹ TS	0.4	4.5	<0.1	0.3
Total-N	g (100 g) ⁻¹ TS	<0.05	0.25	<0.05	<0.05
C/N-ratio		–	18	–	–
Na-AL ^a	mg (100 cm ³) ⁻¹	1.5	2.7	2.4	2.5
K-AL ^a	mg (100 cm ³) ⁻¹	8.6	13.2	7.6	7.9
Mg-AL ^a	mg (100 cm ³) ⁻¹	5.3	11.4	2.9	18.9
Ca-AL ^a	mg (100 cm ³) ⁻¹	68.5	66.2	20.0	165.0
P-AL ^a	mg (100 cm ³) ⁻¹	5.0	4.7	3.7	2.5

^aExtracted by ammonium lactate and acetic acid (AL-method) according to Egnér et al. (1960).

experiments in 2004 had three replications. The soil from Steinskogen, which had too low pH for normal growth of barley in 2003, was limed with 5 g l⁻¹ dolomite before the experiment started in 2004. This increased the pH from 5.2 to 6.0.

Statistical analysis

Analysis of variance (ANOVA) was carried out according to the experimental design for the plot experiments and the field experiments. For multiple comparisons the Tukey's studentized range test (HSD) was used for the field experiments, while the Ryan-Einot-Gabriel-Welch (REGWQ) multiple range test was applied for the pot experiments. The significance level of $P = 0.05$ was used. The GLM procedure (SAS Institute

Inc. 1989) was used to test linear response effects.

Results and discussion

Chemical properties of meat and bone meal

Meat and bone meal was weakly acidic (pH 6.5–6.6). Loss on ignition was 65–75 g/100 g dry matter (DM) (Table 2). Although frequently regarded as organic, the content of the organic fraction (loss on ignition) indicates that about one-third of the material is inorganic and is associated with the bone fraction.

Total nitrogen content was about 8 g/100 g DM, while the ammonium (NH₄-N) and nitrate (NO₃-N) concentrations were rather low (Table 2). Due to

Table 4. Experimental design in pot experiment with spring barley (fertilizer applied 2003).

Treatment	Fertilizer ha ⁻¹ (per pot)	Fertilizer (kg ha ⁻¹)	
		N	P
1	None	0	0
2	360 kg YARA OPTI-KAS (0.53 g)	100	0
3	360 kg YARA OPTI-KAS (0.53 g) + 260 kg YARA OPTI-P (0.37 g)	100	20
4	900 kg YARA Fullgjødsele 11-5-18 (1.34 g)	100	42
5	800 kg MBM (1.23 g) + 180 kg YARA OPTI-KAS (0.25 g)	109	37
6	1600 kg MBM (2.46 g)	117	75
7	1600 kg MBM (2.46 g) + 260 YARA OPTI-P (0.37 g)	117	95
8	3200 kg MBM (4.92 g)	234	149

low C/N ratio (3–4) the nitrogen in MBM may mineralize rapidly after application to soil.

Total (aqua regia extractable) phosphorus varied according to the ratio between meat and bone fraction of MBM, and the mean value of the 2003 production of MBM at the factory at Hamar was about 4.8 g P/100 g DM. Readily available P (AL extractable) represented 33–40% of the total. It is assumed that the P from the organic fraction of MBM is more easily soluble than P in the bone (inorganic) fraction.

The N/P ratio of 1.4–1.9 and C/N ratio of 3–4 were very narrow. This implied that application of MBM to provide adequate N for a crop will invariably result in the application of P amounts in excess of the P needs of that crop.

The low potassium and magnesium contents in MBM (<0.5 g/100 g DM) require annual application of these elements in fertilizer, unless there are sufficient reserves of these elements in the soil. Although the calcium content is high (8–11 g/100 g DM), the weakly acidic reaction (pH 6.5–6.6) indicates that MBM will not influence the soil pH significantly.

The effect of MBM application on yields

Field experiments

The field experiments with spring wheat showed a linear yield increase with increasing amounts of MBM up to 2000 kg MBM ha⁻¹, while for barley a positive yield increase was found for 500 kg MBM ha⁻¹ and no further increase for larger amounts of MBM (Figure 1). In these experiments no significant effect of additional phosphorus (25 kg P ha⁻¹) was found at the treatments with 500 kg MBM ha⁻¹ or more (data not shown).

Pot experiments

The different P application rates in 2003 influenced the barley yield in the pot experiments. By comparison of treatment 2 (with N supply and no P supply) and the other treatments with P supply either as MBM or mineral fertilizer, largest effect of P applications was found for Elverum medium sand and Steinskogen sandy loam, while the effect was also considerable for Ås silt loam (Table 6). The poor yield of the treatments 1, 2 and 3 at Steinskogen sandy loam could partly be related to

Table 5. Experimental design in pot experiment with rye grass (fertilizer applied 2003).

Treatment	Fertilizer ha ⁻¹ (per pot)	Fertilizer (kg ha ⁻¹)	
		N	P
1	None	0	0
2	720 kg YARA OPTI-KAS (1.06 g)	200	0
3	720 kg YARA OPTI-KAS (1.06 g) + 520 kg YARA OPTI-P (0.74 g)	200	40
4	1800 kg YARA Fullgjødsele 11-5-18 (1.34 g)	200	83
5	1600 kg MBM (1.23 g) + 360 kg YARA OPTI-KAS (0.50 g)	217	75
6	3200 kg MBM (2.46 g)	234	149
7	3200 kg MBM (4.92 g) + 520 YARA OPTI-P (0.74 g)	234	189
8	6400 kg MBM (9.84 g)	468	298

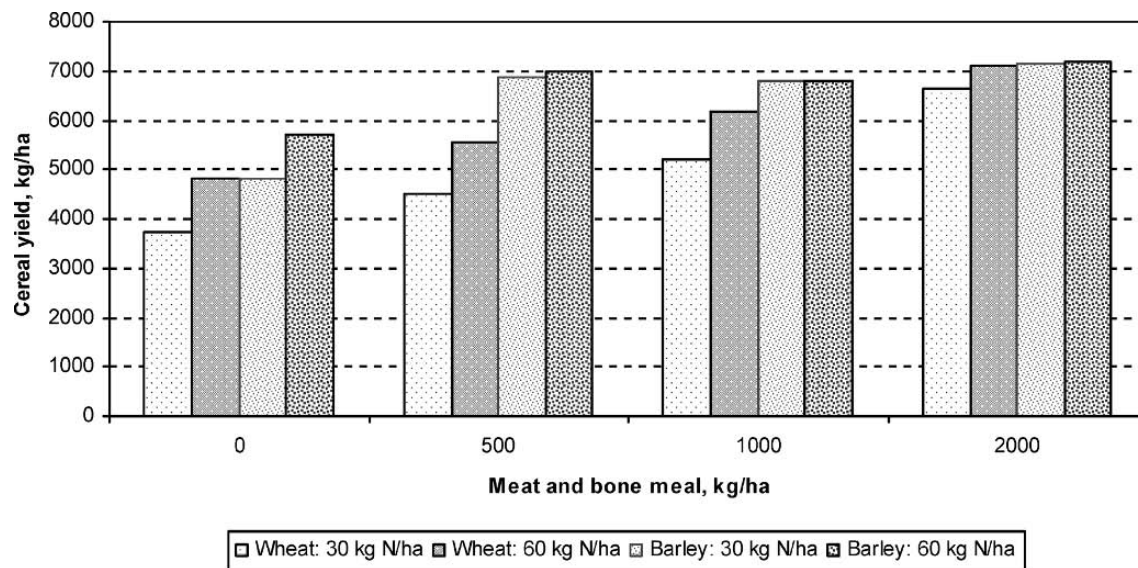

Figure 1. Yield of wheat and barley after MBM and mineral fertilizer application (15% water content).

Table 6. Yield of barley (g DM pot⁻¹) after different P-applications in 2003 to different soils in a pot experiment (means followed by the same letter are not statistically significant ($P > 0.05$)).

Treatment	P (kg ha ⁻¹)	Yield of barley (g DM pot ⁻¹)											
		Øksna		Steinskogen		Elverum		Ås		Mean		Rel. yield	
		2003	2004	2003	2004	2003	2004	2003	2004	2003	2004	2003	2004
1	0	0.6	1.3	1.1	3.4	0.4	0.8	1.9	0.9	1.0f	1.6e	17	30
2	0	5.3	4.5	0.2	4.3	0.5	2.3	4.2	5.2	2.5e	4.1cd	44	77
3	20	5.6	6.7	1.4	6.1	5.4	2.5	6.7	4.8	4.8d	5.0bcd	83	94
4	42	5.7	6.4	3.9	5.4	6.2	2.1	7.2	7.3	5.8bc	5.3abc	100	100
5	37	5.9	4.7	2.6	5.6	5.8	2.6	7.1	2.4	5.4cd	3.8d	93	72
6	75	6.2	6.6	4.5	5.8	6.2	2.7	8.8	7.8	6.4ab	5.7ab	111	108
7	95	6.4	7.1	5.5	5.9	7.6	4.6	9.2	8.2	7.2a	6.5a	125	122
8	149	7.0	7.1	7.2	4.7	4.5	4.0	9.9	8.4	7.1a	6.0ab	124	114

the low pH (5.2), which is lower than recommended for barley. Compared to treatment 4, which represented adequate N and P for 100% yield, there were no significant differences between treatments 4, 5 and 6. Additional application of P did not give significant yield increases when MBM was applied (compare results for treatments 6 and 7). In 2004 when the treatments 2–8 received the same amount of N-fertilizer, the treatments 6, 7 and 8 (with MBM), gave similar yield as treatment 4. The treatment 5 (half amount of MBM compared to treatment 6) gave the same yield as the treatment without added P-fertilizer in 2004.

The P treatments to rye grass gave similar yield response as obtained for barley in 2003 (Table 7).

There was no significant difference between treatments 3, 4 and 5. Treatments 6 and 7 had significantly higher yields than treatment 4. Double amount of MBM (treatment 8) gave significantly increased yield compared to treatment 6. In 2004 there was no significant differences in rye grass yield between the treatments 3, 4 and 5, while larger yields were obtained after the application of MBM in 2003 (treatments 6, 7 and 8).

Effects of different amounts of P on P status in soil

The treatments to which no P fertilizer or MBM was applied had negative P-balance and decreased

Table 7. Yield of rye grass (g DM pot⁻¹) after different P applications in 2003 to different soils in a pot experiment.

Treatment	P (kg ha ⁻¹)	Yield of rye grass (g DM pot ⁻¹)											
		Øksna		Steinskogen		Elverum		Ås		Mean		Rel. yield	
		2003	2004	2003	2004	2003	2004	2003	2004	2003	2004	2003	2004
1	0	1.7	2.2	3.4	4.9	1.0	1.2	1.7	1.3	2.0f	2.2d	18	20
2	0	8.7	9.2	11.0	12.5	4.4	5.1	8.9	8.4	8.3e	8.4c	76	78
3	40	10.0	13.8	11.8	14.3	9.8	8.4	10.3	10.4	10.4d	11.3b	96	105
4	83	10.6	12.6	12.4	14.5	10.5	8.1	9.8	9.7	10.8cd	10.8b	100	100
5	75	9.5	11.9	11.7	14.2	10.4	8.3	10.8	12.1	10.6d	11.4b	98	105
6	149	10.8	12.5	13.0	17.2	10.4	10.6	11.9	12.1	11.5bc	12.8a	106	119
7	189	10.4	13.7	13.1	16.2	10.4	9.3	12.9	13.1	11.7b	12.7a	108	118
8	298	17.9	11.8	20.5	16.4	16.8	12.3	21.3	12.7	19.1a	13.2a	177	122

Sum of three cuts (means followed by the same letter are not statistically significant ($P > 0.05$)).

Table 8. P-balance (mg P pot⁻¹) (applied P – P uptake in crop), and effect of P-supply on readily available P (P-AL) (mg P pot⁻¹) after harvest of barley in 2003 and 2004 (means followed by the same letter are not statistically significant ($P > 0.05$)).

Treatment	Description	P (mg pot ⁻¹)			
		P-balance		P-AL	
		2003	2004	2003	2004
1	No N and P	-3	-6	-14.4c	-33.3cd
2	N fertilizer, no P	-6	-14	-15.3c	-38.4d
3	N + P fertilizer	19	8	-9.9c	-31.2cd
4	Fullgjødse (NPK)	46	32	2.7bc	-26.7cd
5	MBM + N-fertilizer	42	34	-4.2c	-18.9bcd
6	MBM	93	79	13.8bc	-0.6bc
7	MBM + P-fertilizer	121	103	42.6ab	14.7ab
8	MBM double amount	200	182	82.5a	42.9a

in readily available P extracted from soil compared to the P status of the soils before the start of the experiment (Tables 8 and 9). The treatment with N + P fertilizer (treatment 3) showed a positive P-balance, but the readily available P (P-AL) in the soil decreased from the initial P-status in soil. The treatment with Fullgjødse (NPK) 11-5-18 (treatment 4) represented almost no change in readily available P status of the soils from the start of the experiment to after harvest in 2003, but decreased P-AL level after harvest in 2004. Almost equal result as treatment 4 was found at treatment 5 (50% N from mineral fertilizer and 50% N from MBM). The treatments 6, 7 and 8, which received MBM, had a large positive P-balance. The level of readily available P increased in 2003, but after the growing season in 2004 only the treatments 7 and 8 had significantly increased level of readily available P compared to the initial status in the soils (Tables 8 and 9).

General discussion and concluding remarks

Nitrogen effect of meat and bone meal

The MBM was shown to be a very effective N fertilizer for the first crop in all experiments. The soils used in the pot experiments represented forest soil (Steinskogen), subsoil (Elverum and Ås), and recently cultivated soil (Øksna). The soils from Elverum, Ås, and Øksna had very low initial content of soil organic matter (Table 3). Therefore there were small effects of mineralization of N from soil organic matter in these soils, and low yield was obtained at the control treatment (treatment 0). Although the N content in MBM was somewhat higher than expected from previous analyses, the results confirmed the assumption that fertilization effect was approximately 80% of total N in MBM in the first growing season.

Table 9. P-balance (mg P pot⁻¹) (applied P – P uptake in crop), and effect of P supply on readily available P (P-AL) (mg P pot⁻¹) after harvest of rye grass in 2003 and 2004 (means followed by the same letter are not statistically significant ($P > 0.05$)).

Treatment	Description	P (mg pot ⁻¹)			
		P-balance		P-AL	
		2003	2004	2003	2004
1	No N and P	-3	-5	-16.2c	-30.3bc
2	N-fertilizer, no P	-5	-11	-22.5c	-48.3c
3	N + P fertilizer	45	34	-6.3c	-42.0c
4	Fullgjødsel (NPK)	103	93	-3.0c	-20.1bc
5	MBM + N-fertilizer	93	81	-0.3c	-17.4bc
6	MBM	193	176	55.8bc	12.3b
7	MBM + P-fertilizer	246	228	114ab	71.7a
8	MBM double amount	380	359	186a	101a

The field experiments showed varying responses of the crops to applied N as MBM, depending on the N status of the soil and for the yield response when no N was applied. Jeng et al. (2004) found highest yield for the MBM treatment with 2500 kg MBM ha⁻¹, and the treatment with 2000 kg MBM ha⁻¹ had highest yield at Østfold and Hedmark in the present study. At the field experiment in Rogaland there was no further yield increase for larger amounts of MBM than 500 kg MBM ha⁻¹. This result supports findings of Lundström and Lindén (2001) who found very limited yield increase when more than 40 kg N ha⁻¹ in MBM (Biofer) was applied. Large supplies of plant-available soil nitrogen, partly present in the soil in spring and partly released by mineralization during the growing season, may influence the crops need of nitrogen released from MBM. Our results showed that the effect of MBM was largest on soils with low content of soil organic matter (SOM) and limited supply of N mineralized from SOM.

Phosphorus effects of meat and bone meal

The pot experiments showed that MBM was an effective P fertilizer. The soils used in this experiment had low concentrations of readily available P, and P supply in fertilizer was expected to give positive effect on yields. Yields for treatments 3 (P-source YARA OPTI-P) and 5 (P-source MBM) were not significantly different for barley and rye grass, so the relative P efficiency of MBM-P was about 50% compared to phosphate-P in the first crop. The effect of MBM applied in 2003 (treat-

ments 6, 7 and 8) on yields of barley and rye grass in 2004, and positive effect on readily available P in the soils, showed that the P in MBM had residual effect the year after application. The field experiments at Rogaland, Hedmark and Østfold showed that there was no need for additional P when 500 kg MBM ha⁻¹ or more was applied.

Because the N/P ratio of MBM is rather narrow, and represent more P relative to N than normal uptake of cereals, the treatments with MBM applications should increase readily available P in the soils. This effect was confirmed by the pot experiments. We therefore recommend that if MBM is used to meet the N fertilizer demand of the crops, P application the following year should be omitted. Further studies are needed to determine the long term availability of P from MBM in soils.

Acknowledgements

This paper presents results of research projects which have been financially supported by the programme “ORIO-Organic Waste Products and Recycling of Resources” and Norsk Protein, AS (Grant No: 306 and 403). We thank Harald Solberg, Per Ove Lindemark, Arne Vagle, and Ellen Zakariassen for skilful technical assistance and preparation of the results from the experimentst.

References

- Akande M.O., Adediran J.A. and Oluwatoyinbo F.I. 2005. Effects of rock phosphate amended with poultry manure on

- soil available P and yield of maize and cowpea. *Afr. J. Biotechnol.* 4: 444–448.
- Baker A.M., Trimm J.R. and Sikora F.R. 1989. Availability of phosphorus in bone meal. *J. Assoc. Off. Anal. Chem.* 72: 867–869.
- Bekele T. and Hofner W. 1993. Effect of different phosphate fertilisers on yield of barley and rape seed on reddish brown soils of the Ethiopian highlands. *Fert. Res.* 34: 243–250.
- Bremner J.M. 1960. Determination of nitrogen in the soil by the Kjeldahl method. *J. Soil Sci.* 55: 11–33.
- Brewer M.S. 1999. Current status of bovine spongiform encephalopathy – a review. *J. Muscle Foods* 10: 7–117.
- Egnér H., Riehm H. and Domingo W.R. 1960. Untersuchungen über die chemische Bodenanalyse als Grundlage für die Beurteilung des Nährstoffzustandes der Böden. II. Chemische Extraktions Methoden zur Phosphor und Kaliumbestimmung. Statens Jordbruksforsök, Särtryck och Småskrifter nr. 133, Uppsala.
- Fredriksson H., Salomonsson L. and Salomonsson A.C. 1997. Wheat cultivated with organic fertilizers and urea: baking performance and dough properties. *Acta Agric. Scand. Section B-Soil Plant Sci.* 47: 35–42.
- Fredriksson H., Salomonsson L., Andersson R. and Salomonsson A.C. 1998. Effects of protein and starch characteristics on the baking properties of wheat cultivated by different strategies with organic fertilizers and urea. *Acta Agric. Scand. Section B-Soil Plant Sci.* 48: 49–57.
- Hendriks W.H., Butts C.A., Thomas D.V., James K.A.C., Morell P.C.A. and Versteegen M.W.A. 2002. Nutritional quality and variation of meat and bone meal. *Asian Austral. J. Anim. Sci.* 15: 1507–1516.
- Jeng A., Haraldsen T.K., Grønland A., Vagstad N. and Tveitnes S. 2004. Meat and bone meal as nitrogen fertilizer to cereals in Norway. *Agric. Food Sci.* 13: 268–275.
- Kahiluoto H. and Vestberg M. 1998. The effect of Arbuscular Mycorrhiza on biomass production and phosphorus uptake from sparingly soluble sources by leek (*Allium porrum* L.) in Finnish field soils. *Biol. Agric. Hort.* 16: 65–85.
- Kamphues J. 2002. Feeding and feed legislation after the detection of the first indigenous Bse cases in Germany. *Deutsche Tierärztliche Wochenschrift* 109: 362–367.
- Lazarovits G. 2001. Management of soil-borne plant pathogens with organic soil amendments: a disease control strategy salvaged from the past. *Can. J. Plant Pathol. Revue – Canadienne De Phytopathologie* 23: 1–7.
- Lazarovits G., Conn K.L. and Potter J. 1999. Reduction of potato scab, Verticillium wilt, and nematodes by soymeal and meat and bone meal in two Ontario potato fields. *Can. J. Plant Pathol. – Revue Canadienne De Phytopathologie* 21: 345–353.
- Lundström C. and Lindén B. 2001. Nitrogen effects of human urine, meat bone meal (Biofer) and chicken manure (Bina-dan) as fertilisers applied to winter wheat, spring wheat, and spring barley in organic farming. Swedish University of Agricultural Sciences, Department of Agricultural Research, Skara, Series B crops and soils, report 8, 51 pp.
- Novelo L.P., Martinez N.S.L. and Garza V.P. 1998. Bone meal applied to soils of the coffee plantation area in Los Altos de Chipas, Mexico (in Spanish, English summary). *Terra* 16: 71–77.
- SAS Institute Inc. 1989. SAS/STAT User's Guide, Version 6, Fourth Edition, Volume 2, Cary, NC.
- Salomonsson L., Jonsson A., Salomonsson A.C. and Nilsson G. 1994. Effects of organic fertilizers and urea when applied to spring wheat. *Acta Agric. Scand. Section B-Soil Plant Sci.* 44: 170–178.
- Salomonsson L., Salomonsson A.C., Olofsson S. and Jonsson A. 1995. Effects of organic fertilizers and urea when applied to winter wheat. *Acta Agric. Scand. Section B-Soil Plant Sci.* 45: 171–180.
- Surendra S., Singh K.P., Sarkar A.K., Singh B.P. and Gupta B.P. 1993. Release pattern of phosphorus from indigerous phosphatic sources on acid soil. *J. Indian Soc. Soil Sci.* 41: 774–775.

Screening Legume Green Manure for Climatic Adaptability and Farmer Acceptance in the Semi-Arid Agro-ecological Zone of Uganda

J.B. Tumuhairwe^{1*}, M.C. Rwakaikara-Silver¹, S. Muwanga¹ and S. Natigo²

¹Department of Soil Science, Makerere University, P.O. Box 7062, Kampala-Uganda; ²Farmer, Maduudu Sub-County, Mubende District in Uganda; *Corresponding author: jbtumuhairwe@agric.mak.ac.ug

Abstract

Crop yields in Uganda are severely limited by declining soil fertility. Nitrogen (N), phosphorus (P) and soil organic matter (SOM) are the most limiting factors, yet legume green manures are known to fix N₂ and increase SOM. Legume green manure technology has proved suitable for smallholder and subsistence farmers in sub-Saharan Africa. In Uganda, the spread of the technology has so far been concentrated in the central and eastern part of the country. Therefore, this study aimed at scaling out the legume green manure technology in the western semi-arid and cattle corridor zone of Uganda through on-farm researcher-designed, researcher/farmer managed village trials. For this purpose the six legumes namely *Crotalaria grahamiana*, *Crotalaria ochroleuca*, *Mucuna pruriens*, *Canavalia ensiformis*, *Lablab purpureum* and *Tephrosia vogelli* were tested in plot of 10 m by 10 m in a randomized complete block design whereby each farm site represented a replicate. Six months after planting of the legumes, farmers were individually asked to select their preferred species and to name the reasons for their choice. Subsequently, the legume biomass was determined and incorporated in the soil prior to planting maize. *C. ensiformis* and *T. vogelli* were the most and least preferred species, respectively, *C. ensiformis* yielded the highest (5.2 t ha⁻¹) and *T. vogelli* the lowest (2.0 t ha⁻¹) biomass. Highest maize grain yields were obtained from plots of *M. pruriens* (3.5 t ha⁻¹), but they were not significantly different from those of *C. ensiformis* with 3.4 t ha⁻¹. Incorporation of the natural fallow vegetation led to the lowest maize grain yields (1.9 t ha⁻¹).

Key words: *Canavalia ensiformis*, *Crotalaria grahamiana*, *Crotalaria ochroleuca*, *Lablab purpureum*, *Mucuna pruriens*, soil fertility, *Tephrosia vogelli*

Introduction

Agriculture is still the mainstay of Uganda's economy predominated by crop production. However, crop yields on smallholder farms are steadily declining due low soil fertility. Like in other parts of sub-Saharan Africa, negative nutrient balances have been reported for all major farming systems in Uganda (Wortmann and Kaizzi, 1998) whereby N is more rapidly depleted than other nutrients (Walaga *et al.*, 2000). The situation has been aggravated by a rapid population growth leading to an ever declining amount of arable land

per capita and an increase in area under continuous cropping. Notably smallholder farmers have limited ability to purchase soil fertility inputs, in particular inorganic fertilizers (Bekunda *et al.*, 1997). Consequently, there has been accelerated nutrient mining. In this context legume green manures have a particularly large potential to improve the soil fertility on smallholder farms (Mureithi *et al.*, 2003).

Realizing the impact of low soil fertility on their crop yields, farmers in Uganda have attempted to alleviate it by the targeted recycling of crop residues and animal manure. However, these efforts have been

constrained by poor quality of such amendments and lack of adequate amounts to apply to the entire farm. Secondly, these organic materials are bulky and this has severely limited their application to further fields. As a result, most farming systems in Uganda are becoming unsustainable.

While nitrogen is limiting crop production, it is abundant in the atmosphere and can cheaply be harnessed for crop production through biological nitrogen fixation. Estimates of symbiotic N₂ fixation in legumes vary from 25–280 kg N ha⁻¹yr⁻¹ (Sanchez *et al.*, 1997). Therefore, the systematic utilization of legumes in farmers cropping systems can play a great role in replenishing N and increasing crop yields. Additionally, incorporation of legume residues enhances SOM and can improve the soil's physical properties. They also provide ground cover and conserve soil against erosion (Lal *et al.*, 1991). Some legume species can be utilized as food or fodder and therefore have a particular potential to become an integral part of smallholder farming systems in Uganda.

So far the use of legume green manure in Uganda has been concentrated in eastern and central part of the country where there is relatively high rainfall (>1500 mm per year). Success story on adoption of legume green manures in this region has been reported in Ikulwe community of Iganga District (Fischler 1997; Fischler and Wortmann, 1999). Therefore, this study introduced selected legume species to the drier, cattle corridor of the country, where in addition to declining soil fertility, the farmers are constrained by pasture for their animals. Since most of these selected legume green manure species are drought tolerant, they could substitute for pasture while increasing agricultural biodiversity.

Materials and methods

Site characteristics

The study was conducted in Mubende district located in the wooded savannah of Uganda at. It lies on 31°40'E and 0°25'N, and altitude ranges from 1372–1448 m asl and with annual rainfall varying from 1000–1200 mm. This area is part of the cattle corridor zone of Uganda characterized by free range grazing and crops which are equally grown. The soils are loamy but deficient of major plant nutrients.

Research design

As this was the first legume green manure extension activity in the area; a one day sensitization workshop using Participatory Rural Appraisal (PRA) tools was organized to inform farmers about this innovation. From the farmers who attended the meeting, 10 farmers were selected to host the trials on their farm. The most important selection criterion for the farmers was their accessibility to others in different villages of Maduudu sub-county where communities from different village could easily gather to monitor the experiment and learn. Subsequently, the selected farmers were requested to identify parts of their land that they considered of low fertility and thus appropriate for the soil fertility enhancement experiment.

A composite soil sample was collected at each experimental site and six plots of 10 m by 10 m were demarcated. The soil samples were brought to the Soil Science Laboratory at Makerere University, air-dried, ground and sieved through a 2 mm sieve and analyzed for pH, SOM, total N, available P, exchangeable bases of sodium (Na), potassium (K), magnesium (Mg) and calcium (Ca), and texture using standard procedures described by Okalebo *et al.* (1993). Subsequently, each field was manually ploughed then harrowed and planted with the following legume green manures species: *Crotalaria grahamiana*, *Crotalaria ochroleuca*, *Mucuna pruriens*, *Canavalia ensiformis*, *Lablab purpureum* and *Tephrosia vogelli*. The seeds were obtained from CIAT (Uganda) at Kawanda having been collected from farmers in eastern Uganda where the technology has been used for over ten years. *Crotalaria grahamiana*, *C. ochroleuca*, *L. purpureum*, *C. ensiformis*, *M. pruriens* were planted at a spacing of 0.7 m by 0.3 m and *T. vogelii* at 0.7 m by 0.6 m. The researcher-designed experiment was managed by the researcher and farmers. The farmers ploughed and harrowed the land, and were guided in planting the legume and maize seed, monitored plant development, harvested and incorporated the legume biomass. Similarly, they were guided in the management of the following test crop and recorded its grain yield. Treatments were arranged in a randomized complete block with each farmer representing a replicate.

The legume green manure crops were planted in March 2002, cut down and weighted in September 2002 having grown for six months and incorporated *in-situ*. Following incorporation, all plots were planted with the improved maize variety Longe IV at the recommended spacing of 0.7 m by 0.3 m whereby a single plant

per hole was maintained at thinning two weeks after planting. A control treatment of incorporated natural vegetation fallow was used for comparison. It consisted of a neighboring field on each site that was under natural vegetation since March 2002, when the legume green manures were planted. The variety and density of maize planted on this control plot was identical to those one of the other treatments. Weeding was manually done with a hand hoe and there was no serious pest and disease infestation. At physiological maturity, maize was harvested and grain yield determined after sun drying to weight constancy.

Farmers' preferences on the legume green manure species

Farmers were asked to closely monitor the experiment right from planting stage. A few weeks before cutting down the legume biomass, five farmers of each village were asked to identify their preferred species. A ranking scale of 1 to 6 was used because there were six species to be ranked. Farmers were asked to provide reasons for their selection guided by a structured questionnaire inquiring impressions about perceived variety traits such as resistance to drought, pests and diseases and about vegetative growth and weed suppression.

Data analysis

Data of legume biomass and maize grain yield were subjected to analysis of variance using GENSTAT and mean difference determined at a significance level of 5%. Also recorded and analyzed were maize grain yield

data of the second (residual) season after incorporation of the legume or fallow vegetation biomass. Qualitative data about farmers' preferences were tabulated for frequencies.

Results and discussion

Soils

All ten farms had sandy clay loam to sandy loam soils with plant available P (Bray P) values $< 10 \text{ mg kg}^{-1}$. Seven of the farm soils had N levels below the critical value of 2% (Table 1). Surprisingly, all soils had a relatively high SOM which could be the result of farmers having selected those parts of their often relative large holdings as infertile that were left fallow and used for grazing animals.

Green manure biomass

The highest above ground legume biomass was recorded from *C. ensiformis* and the least yield from *T. vogelli* (Table 2).

Maize yield

Grain yields in natural vegetation fallow plots were significantly ($p < 0.05$) lower than in any of the legume green manure plots. Among the legume species *M. pruriens*, *C. ensiformis* and *L. purpureum* were followed by significantly higher maize yields than *C. grahamiana*, *C. ochroleuca* and *T. vogelli* (Table 3).

Table 1. Soil characteristics of the 10 selected on-farm sites in Uganda at 0–20 cm depth.

Farmer's name	pH	%OM	%N	Av. P	K	Na	Ca	Mg	Sand	Clay	Silt
				mg kg ⁻¹							
Site 1	5.9	6.5	0.20	3.33	0.61	0.08	8.4	1.93	60	28	12
Site 2	6.3	5.25	0.20	2.97	0.77	0.10	8.8	1.7	56	28	16
Site 3	6.3	2.88	0.13	3.12	0.66	0.09	5.6	0.86	62	26	12
Site 4	6.6	4.30	0.17	3.63	1.17	0.15	8.9	1.29	70	18	12
Site 5	6.4	3.39	0.13	3.02	0.61	0.09	5.0	0.91	64	28	8
Site 6	5.9	4.73	0.17	5.76	0.51	0.05	7.5	1.32	52	34	14
Site 7	6.6	5.25	0.17	9.10	1.53	0.18	10.7	1.68	64	24	12
Site 8	6.6	3.00	0.10	9.42	0.92	0.12	5.1	0.68	74	14	12
Site 9	5.8	2.92	0.13	3.43	0.71	0.07	5.0	1.08	62	30	8
Site 10	6.6	4.90	0.20	7.36	1.38	0.18	8.4	1.27	62	26	12
Mean	6.3	4.31	0.16	5.11	0.89	0.11	7.34	1.27	62.6	25.6	11.8

Table 2. Total dry matter (TDM) of legume green manure plants after six months in Mubende, Uganda.

Species	Mean TDM (t ha ⁻¹)
<i>C. ensiformis</i>	5.22
<i>M. pruriens</i>	4.18
<i>C. grahamiana</i>	3.88
<i>C. ochroleuca</i>	3.45
<i>L. purpureum</i>	3.20
<i>T. vogelii</i>	2.03
SED	0.585
F-value of a treatment effect	< 0.001

Table 3. Maize grain yield (t ha⁻¹) following incorporation (season 1) and 5 months (season 2) after the incorporation of natural fallow vegetation or a legume manure crop. Data show means of ten on-farm trials in Mubende, Uganda.

Treatment	Season 1	Season 2
Natural fallow (control)	1.91	0.63
<i>C. grahamiana</i>	2.87	1.16
<i>C. ochroleuca</i>	2.80	1.12
<i>C. ensiformis</i>	3.43	2.14
<i>M. pruriens</i>	3.48	1.80
<i>L. purpureum</i>	3.41	1.16
<i>T. vogelii</i>	2.69	1.10
SED	0.411	0.281

When maize was grown in the same plots for the second season (season 2 in Table 3), a similar trend was observed but grain yields were relatively low, in most cases less than those of the natural vegetation fallow plots in the first season except for *C. ensiformis*. This might be due to drought conditions in this season. Climatic data were not provided but this area experiences average rainfall of 1000 mm per annum for a short period of time and dry most of the year.

Farmers' preferences

C. ensiformis was the most preferred species, followed by *C. grahamiana*, the least preferred was *T. vogelii*. *C. ensiformis* was placed at 5 of the 10 sites in the 1st position compared to *T. vogelii*, which was placed in 6th position at 5 of the 10 sites (Table 4).

Farmers based their ranking of legumes mainly on plant biomass, growth vigor and germination. For instance, *C. ensiformis* produced the largest above

Table 4. Farmers' preference ranking for legume green manure species in Mubende, Uganda.

Species	Frequency in rank position					
	1	2	3	4	5	6
<i>M. pruriens</i>	1	2	3	2	2	0
<i>C. ensiformis</i>	5	3	1	1	0	0
<i>L. purpureum</i>	1	0	2	0	4	3
<i>C. grahamiana</i>	1	0	3	5	0	1
<i>C. ochroleuca</i>	2	5	0	0	2	1
<i>T. vogelii</i>	0	0	1	2	2	5

ground biomass on most farms, showed fast germination and was of great vigor. At sites where *L. purpureum* was ranked first farmers opted for its use as an animal feed rather than for soil fertility improvement. However, it appeared to be more susceptible to drought stress than most species and was attacked by defoliators after germination. Nevertheless, farmers acknowledged that all legume species were more tolerant to drought than the natural vegetation. Apparently, there was a dry spell during this season with erratic rainfall of less than 300 mm. On one site farmers were astonished by how *M. pruriens* smothered couch grass (*Digitaria* spp), one of the most serious weeds in the area, and were willing to grow it on large scale. *C. ochroleuca* was preferred because of its rapid growth and seed production. However, acceptance of *Crotalaria* spp. was hampered by its susceptibility to pest attack, which farmers thought would also infest their leafy crops such as tobacco.

Conclusions

Legume green manures seem to have a high potential for improving soil fertility in Mubende district. *M. pruriens*, *C. ensiformis* and *L. purpureum* exhibited a better performance than the other legumes used in this series of on-farm experiments. *C. ensiformis* was the most preferred species in Mubende and *L. purpureum* ranked high with farmers having livestock.

Acknowledgement

The authors are very grateful to AfNet-TSBF/CIAT for the financial and technical support to conduct the study.

References

- Bekunda M.A., Bationo A. and Ssali H. 1997. Soil fertility management in Africa. A review of the selected trials. In: Buresh R.J., Sanchez P.A. and Calhoun F.G. (eds.) *Replenishing Soil Fertility in Africa. Special Publication No.51 of Soil Science Society of America, Madison Wisconsin*, pp. 63–79.
- Fischler M. 1997. Legume green manures in the management of maize-bean cropping systems in eastern Africa with special reference to *Crotalaria (C. ochroleuca G. Don.)*. Ph.D. thesis No. 12099 ETH Zurich.
- Fischler M. and Wortmann C.S. 1999. Green manures maize-bean systems in eastern Uganda: Agronomic performance and farmers' perception. *Agroforestry Systems* 47: 123–138.
- Lal, R., Reigner E., Edwards W.M. and Hammond R. 1991. Expectations of cover crops for Sustainable agriculture. In: Hargrove W. L. (ed.). *Proceedings Cover crop for clean water: an international Conference*, West Tennessee Experiment Stations, 9–11 April 1991. Soil and Water Conservation Society, Ankeny, IA, USA, pp. 1–11.
- Mureithi J.G., Gachene C.K.K. and Ojiem J. 2003. The role of green manure legumes in smallholder farming systems in Kenya: The Legume Research Network Project. *Tropical and Subtropical Agroecosystems*. 1: 57–70.
- Okalebo J.R., Gathau K.W. and Woomer L.P. 1993. Laboratory methods of soil and plant analysis. A working manual.
- Sanchez P.A., Buresh R.J. and Leakey R.R.B. 1997. Trees, Soils and Food security. *Phil. Trans. R. Soc. London B* 352: 949–961.
- Walaga C., Egulu B., Bekunda M. and Ebanyat P. 2000. Impact of policy change on soil fertility management in Uganda. In: Hilhorst, T. and Muchena, F.M. (eds.). *Nutrients on the move –soil fertility dynamics in Africa farming systems*. International Institute for Environment and Development. pp. 29–44.
- Wortmann C.S. and Kaizzi C.K. 1998. Nutrient balances and expected effects of alternative practices in farming systems of Uganda. *Agriculture, Ecosystems and Environment* 17: 115–129.

Nutrient flows in smallholder production systems in the humid forest zone of southern Cameroon

J. Kanmegne^{1,*}, E.M.A. Smaling^{2,3}, L. Brussaard⁴, A. Gansop-Kouomegne⁵ and A. Boukong⁵

¹Institute of Agricultural Research for Development, IRAD/ICRAF collaborative agroforestry project, P. O. Box 2067, Messa-Yaounde, Cameroon; ²International Institute for Geo-Information Science and Earth Observation (ITC), P.O. Box 6, 7500 AA Enschede, The Netherlands; ³Plant Production Systems Group, Wageningen University, P.O. Box 430, 6700 AK Wageningen, The Netherlands; ⁴Department of Soil Quality, Wageningen University, Dreijenplein 10, 6703 HB Wageningen, The Netherlands; ⁵Faculty of Agronomy and Agricultural Sciences, University of Dschang, P.O. Box 222, Dschang, Cameroon; *Author for correspondence (jkanmegne@hotmail.com)

Key words: Humid forest, Nutrient budget, Nutrient flows, Traditional land uses

Abstract

The flows and balances of N, P and K were studied in 20 farms in the Campo Ma'an area in Cameroon between March and August 2002 to assess the nutrient dynamics in smallholder farms. Data were collected through farmer interviews, field measurements and estimates from transfer functions. Nutrient input from mineral (IN1), animal feed (IN2a) and inorganic amendments (IN2b) was absent. Major outputs were through crop (OUT1a) and animal (OUT1b) products sold. Partial budgets for farmer managed flows were negative: -65 kg N, -5.5 kg P and -30.8 kg K ha^{-1} year $^{-1}$. For inflows not managed by farmers, deep capture (IN6) was the major source: 16.6, 1.4 and 6.6 kg ha^{-1} year $^{-1}$ of N, P and K, respectively. Atmospheric deposition (IN3) was estimated at 4.3 kg N, 1.0 kg P and 3.9 kg K ha^{-1} year $^{-1}$, and biological nitrogen fixation (IN4) at 6.9 kg N ha^{-1} year $^{-1}$. Major losses were leaching (OUT 3a): 26.4 kg N, and 0.88 kg K ha^{-1} year $^{-1}$. Gaseous losses from the soil (OUT 4a) were estimated at 6.34 kg N, and human faeces (OUT 6) were estimated at 4 kg N, 0.64 kg P and 4.8 kg K ha^{-1} year $^{-1}$. The highest losses were from burning (OUT 4c), i.e. 47.8 kg N, 1.8 kg P and 14.3 kg K ha^{-1} year $^{-1}$. Partial budgets of environmentally controlled flows were negative only for N -4.8 kg N, $+2.4$ kg P and $+9.6$ kg K ha^{-1} year $^{-1}$. The overall farm budgets were negative, with annual losses of 69 kg N, 3 kg P and 21 kg K ha^{-1} . Only cocoa had a positive nutrient balance: $+9.3$ kg N, $+1.4$ kg P and $+7.6$ kg K ha^{-1} year $^{-1}$. Nutrients reaching the household waste (1.9 kg N, 2.8 kg P and 18.8 kg K ha^{-1} year $^{-1}$), animal manure (4.9 kg N, 0.4 kg P and 1.6 kg K), and human faeces (4 kg N, 0.64 kg P and 4.8 kg K ha^{-1} year $^{-1}$) were not recycled. Five alternative management scenarios were envisaged to improve the nutrient balances. Recycling animal manure, household waste and human faeces will bring the balance at -62.6 kg N, 0 kg P and $+1$ kg K ha^{-1} year $^{-1}$. If, additionally, burning could be avoided, positive nutrient balances could be expected.

This article has been previously published in the journal "Nutrient Cycling in Agroecosystems" Volume 76 Issues 2–3.

Introduction

In sub-Saharan Africa, stakeholders and decision makers progressively recognize the depletion of soil nutrients as a major constraint to sustainable agriculture and rural development (Smaling et al. 1993, 1996). Stoorvogel and Smaling (1990) estimated for southern Cameroon for 2000: 21 kg N, 2 kg P and 13 kg K loss per ha and per year. One of the difficulties to reverse the trend is the farmers' limited access to fertilizers and the subsequent vicious circle of soil fertility depletion and poverty (Sanginga et al. 2003).

Soil qualities at farm scale depend on the nutrient management by farmers: the manipulation of nutrient stocks and flows, nutrient inputs in the system through organic and chemical amendments, nutrient export via crop harvest and crop residue removal, and conversions within the production systems (Bationo et al. 1998; Deugd et al. 1998). Smallholders in southern Cameroon recognize spatial soil heterogeneity within farms and adjust land management accordingly (Westphall et al. 1981; Buttner and Hauser 2003).

Nutrient budgets of agroecosystems can be used as a tool to increase the understanding of nutrient cycling, or as a performance indicator and awareness raiser in nutrient management and environmental policy (Oenema et al. 2003). In sub-Saharan Africa, information on the dynamics of total nutrient stocks in the primary forest ecosystem and in subsequent land uses, i.e. budgets and flows between the different production compartments, is scarce (Juo and Manu 1996; Kotto-Same et al. 1997).

Smaling et al. (1996) and Van den Bosch et al. (1998) presented the nutrient-monitoring concept, which considers five units within farms: crop production, animal production, household, stock or family store, and redistribution (Figure 1). They considered six nutrient flows into the farm, i.e., inorganic fertilizers (IN1), organic inputs (IN2), wet and dry deposition (IN3), biological nitrogen fixation (IN4), sedimentation (IN5), and deep capture (IN6), and six outflows, i.e. through harvested crop products (OUT1), crop residues leaving the farm (OUT2), leaching (OUT3), gaseous losses (OUT4), water erosion (OUT5), and human faeces (OUT6). Internal flows refer to the redistribution of crop and animal products, crop

residues, animal manure and household waste in the different units of the farm.

The present paper uses this approach to calculate nutrient balances in 20 farms of the Campo Ma'an area, focusing on the farm as a whole, and then on the subsystems within the farm (crop fields and the different land uses, farm animals, and household). Codification of the various nutrient flows investigated in this study are summarized in Table 1. The main objective is to contribute to the understanding of the degree of nutrient depletion and identify major constraints to integrated nutrient management. Alternative management scenarios are also envisaged, to redress the system nutrient balance.

Materials and methods

The study site

The study was conducted in four villages: Asseng, Ma'an-village, Messama III and Mvi'illimengale, located in the Ma'an sub-Division of the agroforestry zone of the Campo Ma'an National Park, southern Cameroon. The site is located between longitude 10°10'–10°70' East and latitude 2°–3° North, and is characterized by a sub-equatorial climate, with a bimodal rainfall regime. The mean annual temperature is 24°C with a relatively small thermal variation. The mean annual rainfall is 1900 mm. The soils are Oxisols/Ultisols, which make up about 80% of the soils in the humid forest region of Cameroon, with low cation exchange capacity, but excellent physical properties, with 24–34% clay. The general soil properties are summarized in Table 2.

The population density of the site is low, 3.5 inhabitants/km², the major ethnic groups are Ntoumou, Mvae and Bulu. Agriculture is the main activity of 84% of the population, while hunting and fishing is practiced by 15%. The household size is 5–7.

Every year, a mature secondary forest or a long fallow plot is slashed and burned, then planted to ngon (*Cucumeropsis manii*) and plantain (*Musa sp.*). This land use is called *essep*. The ngon is harvested within one year. This land use is the major source of household revenue. The plot will then be managed for banana and plantain production, for one to two years. Usually, after

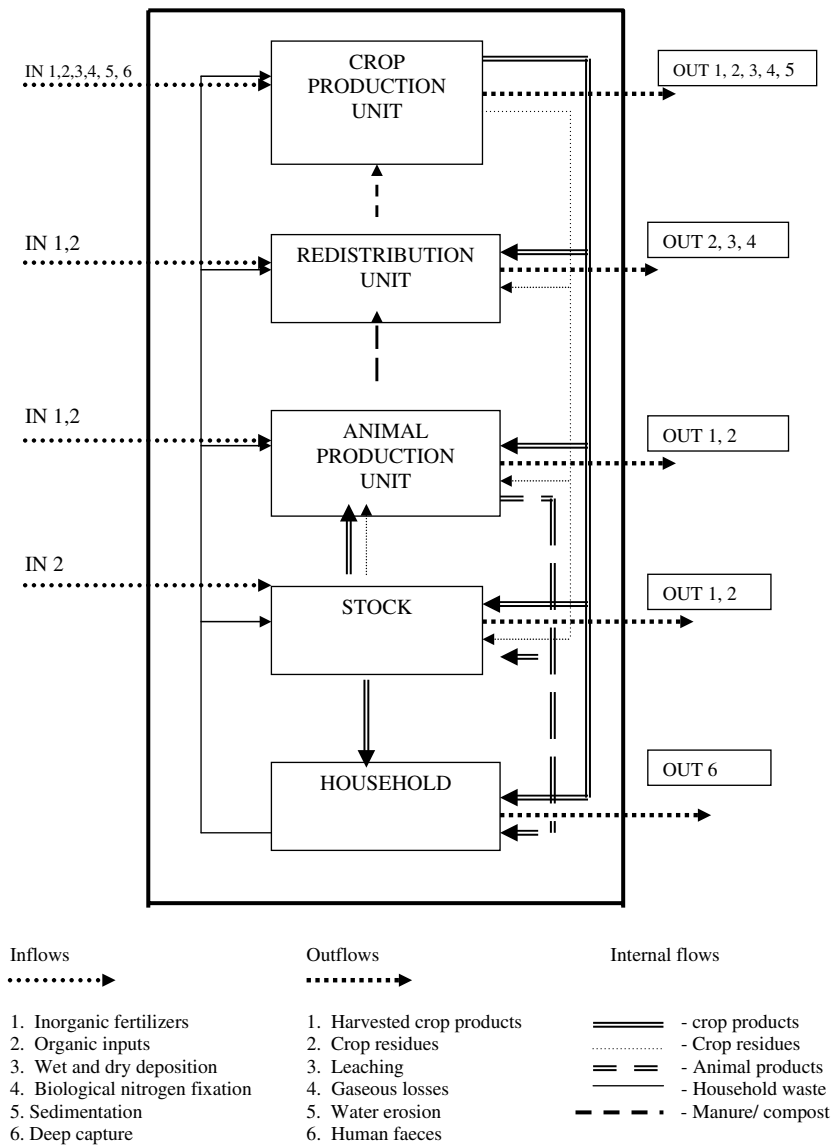

Figure 1. Conceptual framework of nutrient flows and budgets, indicating the major inflows (IN), outflows (OUT) and internal flows (FI) of nutrients in a farm system.

banana the plot is left for a short fallow of 2–3 years, then slashed and burned and planted to various food crops. The major crops are groundnut (*Arachis hypogaea*) and cassava (*Manihot esculenta*). This land use is called afup owondo, and largely guarantees household food security and, in areas with market access, generates marketable surpluses. Cocoa plantations are a mixture of cocoa, a multitude of trees with food and medicinal values, and timber tree species either

planted by farmers or retained during the initial forest clearing. Cocoa plantations are the predominant productive land use and until the collapse of cocoa prices in the late 80 s, cocoa systems were the main source of household income. Each household on average manages annually 1.16 ha essep, 0.4 ha banana farm, 1.0 ha afup owondo and 3.5 ha cocoa. A total of 120 ha of agricultural land, managed by the 20 selected households, was surveyed in the course of this study.

Table 1. Codification of nutrient flows calculated or estimated in the study.

Code	Flows
<i>Inflows</i>	
IN1:	Inorganic fertilizers
IN2:	Organic inputs
	IN2a: manure, feed, concentrates
	IN2b: organic fertilizers
	IN2c: fuel wood
IN3:	Wet and dry depositions
IN4:	Biological nitrogen fixation
	IN4a: symbiotically fixed nitrogen
	IN4b: non- symbiotically fixed nitrogen
IN5:	Sedimentation
IN6:	Deep capture
<i>Outflows</i>	
OUT1:	Harvested products
	OUT1a: crop products leaving the farm
	OUT1b: animal products leaving the farm
OUT2:	Farm residues
	OUT2a: crop residues leaving the farm
	OUT2b: animal manure leaving the farm
OUT3:	Leaching
	OUT3a: leaching below the root zone
	OUT3b: leaching from the garbage heap
OUT4:	Gaseous losses
	OUT4a: gaseous losses from the soil
	OUT4b: gaseous losses from animal manure
	OUT4c: gaseous losses from burning of the natural vegetation
OUT5:	Water erosion
OUT6:	Human faeces
<i>Internal flows</i>	
F11:	Animal browsing from crop residues
F12:	Household waste
	F12a: animal consumption from household waste
	F12b: decomposition of household waste
F13:	Redistribution of crop residues
F14:	Animal browsing from external pasture
F15:	Redistribution of manure by farm animals
F16:	Farm products used by the household
	F16a: crop products used for food
	F16b: animal products used for food

Quantification of the different nutrient flows

Nutrient flows managed by farmers

The survey was conducted from March to August 2002, in 20 households. Biophysical, socio-economic and farming system data were collected through household interviews. Farmers gave information on the different production compartments, the different land uses, and their

Table 2. Soil properties of the study site, Ma'an in southern Cameroon (forest soil).

Soil properties	Soil depth (cm)			
	0–5	5–10	10–20	20–50
pH (1:1 soil:water)	3.95	3.98	4.16	4.51
pH (KCl)	3.81	3.91	4.07	4.37
O.M (%)	7.55	5.17	3.55	1.98
C (%)	4.38	3.00	2.06	1.55
Total N (%)	0.215	0.161	0.116	0.067
Ca (cmole kg ⁻¹)	0.143	0.110	0.074	0.027
Mg (cmole kg ⁻¹)	0.135	0.095	0.056	0.024
K (cmole kg ⁻¹)	0.116	0.077	0.056	0.019
Na (cmole kg ⁻¹)	0.008	0.006	0.025	0.006
Total bases (cmole kg ⁻¹)	0.402	0.288	0.206	0.075
Extractable P (ppm)	5.96	3.56	1.82	0.29
Sand (%)	66	62	60	54
Clay (%)	24	26	30	34
Silt (%)	10	12	10	12

major farm products and destinations. Nutrient flows were quantified by asking farmers and through direct measurements on the farm or in the household. The inflows investigated by asking farmers were: the quantities of mineral fertilizers (IN1), organic inputs such as manure, feedstuffs, concentrates and outside grazing by farm animals (IN2a) and organic fertilizers (IN2b), and fuel wood (IN2c) entering the farm annually. The outflows included crops (OUT1a) and animal products (OUT1b) leaving the farm as gifts or sales. Outflows measured were crop residues (OUT2a), and animal manure (OUT2b) leaving the farm. Nutrient loss through human faeces (OUT6) was estimated as 80% of nutrients in crop and animal products effectively consumed by the household, assuming that the human body assimilates 20% of the nutrients contained in food. Farmers generally gave quantities in their own units, such as sacks, bags and buckets, which were converted to standard metric amounts. Also all classes of farm animals were counted and weighed. For each farmer, a field survey allowed us to identify the different land uses, the number of plots under each land use, and to estimate the surface area of each plot. This helped to estimate the different yields. The different products were sampled, and analyzed for major nutrients N, P, K, for quantification of the nutrient flows. Nutrient flows presented hereafter refer to a unit farm area.

Measurement of internal flows. The flows between the different farm compartments were measured and included feed for farm animals (F11), household waste (F12), its consumption by animals (F12a), and the decomposing part (F12b), crop residues (F13), grazing of vegetation (F14), animal manure (F15), crop (F16a) and animal (F16b) products used for food by the household. Data on feed for farm animals (F11) was recorded from farmer interviews, and data on household waste (F12) determined by weighing daily all the waste from the selected households during the experimental period.

Animal consumption of household waste (F12a). Household waste was weighed daily and supplied to farm animals. The residuals not eaten by the animal were weighed in the evening. This operation was conducted during 30 days in the different households, and separately for the different types of waste leaving the kitchen. The consumption factor (F_i) was determined for each type of waste (quantity supplied to the animal over the quantity eaten by the animals). The nutrient flow from the household waste to farm animals was determined for each type of waste i as:

$$F12b = (F_i * Q_i * C_i) * (F_s)^{-1}$$

where F is the consumption factor of the waste, Q the quantity of waste deriving from the crop, C the nutrient content of the waste, and F_s the farm size.

Decomposition of household waste (F12c). The decomposition of household waste was calculated as the difference between the nutrients in the waste produced by the household (F16c), and the quantities of N, P, and K consumed by the farm animals (F12b). We assumed that the losses through volatilization and leaching during decomposition were negligible.

Crop residues from farm to household (F13): Crop residues were not purposely removed from the farm. All crop residues were mulched on the field.

Animals browsing on external pasture (F14). The quantity of fodder eaten by animals from pastures along the road or from the cocoa farm where they freely roam was estimated from the manure

production. We assumed that nutrients in animal manure represent 80% of total consumption of feeds and fodder.

Production of manure by the farm animals (F15). The quantity of manure produced by the different animal groups was estimated from the live weight (L_w) of the animal. Small ruminants consume 3.2% of their live weight as feed daily (F_d), and the mean digestibility (D) is 60%. The daily production of manure by pigs was estimated at 0.69% of their live weight, for poultry at 1.68% of their live weight. Daily urine production was estimated at 2–6 litters for pigs, and 0.5–2 litters for sheep and goats (Tchoumboue 1980). It is also considered that 60% of excreted N (Haynes and Williams 1993) and 70–90% of excreted K (Barrow 1987) are through urine. The quantity of a nutrient Y excreted by a small ruminant in manure per unit farm area was estimated through the equation:

$$F15(Y) = L_w * F_d * (1 - D) * 365 * Y_m * (F_s)^{-1}$$

where Y_m is the Y content in manure. *Farm products used by the household (F16):* The quantity of farm products used by the household was estimated from interviews, and samples of the different products analyzed for nutrient N, P, K.

Estimation of inflows not managed by farmers. Nutrient inflows not managed by farmers were estimated from transfer functions, site climate and soil data. These included atmospheric deposition (IN3) and biological nitrogen fixation (IN4). Atmospheric depositions (IN3) correlate to rainfall (p), and have been estimated from functions developed by Stoorvogel and Smaling (1990).

$$IN3(N) = 0.14 * p^{1/2}$$

$$IN3(P) = 0.023 * p^{1/2}$$

$$IN3(K) = 0.092 * p^{1/2}$$

Biological nitrogen fixation (IN4) in production systems was estimated from the general equation:

$$IN4(N) = [(S_{afup} * IN4a) + (F_s * IN4b)] * [F_s]^{-1}$$

where S_{afup} is the groundnut field area or $afup$, F_s is the farm size, IN4a is the symbiotically fixed

and IN4b the non-symbiotically fixed nitrogen. It was assumed that 60% of the total N demand of groundnut crop is supplied through symbiotic nitrogen fixation (Stoorvogel and Smaling 1990).

$$\text{IN4a} = [\text{OUT1(N)} + \text{FI3(N)}] * 0.6 + [2 + (p - 1350) * 0.005]$$

where OUT1 (N) is the N exported in groundnuts, and FI3a, the quantity of N accumulated in crop residues. At the site, groundnut yield (G_y) was 273 kg ha⁻¹, haulm to grain ratio (R) of groundnut was 2.76, and N content was 1.96% in haulms and 3.8 % in grains, therefore:

$$\text{OUT1(N)} = 0.038 * G_y$$

and

$$\text{FI3a(N)} = 2.76 * 0.0196 * G_y$$

Non-symbiotic nitrogen fixation was estimated from the function (Smaling et al. 1993)

$$\text{IN4b(N)} = 2 + (p - 1350) * 0.005$$

Deep capture (IN6). Litter fall estimation in the different land uses, followed the methodology described by Anderson and Ingram (1993). Litter traps were set in the different land uses, and litter collected over the whole year. The collected material was oven-dried, weighed, sub-sampled and analyzed for N, P, and K. The nutrient input to the system was calculated by multiplying annual litter fall and the nutrient concentration. We assumed that 75% of nutrients in the litter is recycled in the root zone, and that 25% is deep capture from below the root zone, as most trees on acid soils have 70–80% of their roots in the top 50 cm (Szott 1995).

Estimation of nutrient outflows not managed by farmers

Leaching below the root zone (OUT3a). In tropical soils P is tightly bound to soil particles. The quantities of N and K annually lost through leaching (in kg ha⁻¹ year⁻¹) were estimated from the transfer functions developed by Smaling (1993):

$$\text{OUT3a (N)} = (\text{N}_{\text{min}} + \text{N}_{\text{fert}}) * (2.1 * 10^{-2} * p + 3.9)$$

$$\text{OUT3a (K)} = (\text{K}_{\text{exch}} + \text{K}_{\text{fert}}) * (2.9 * 10^{-4} * p + 0.41)$$

where N_{min} is the quantity of N mineralized in the top 30 cm of the soil, N_{fert} is the fertilizer N, K_{exch} is the exchangeable K and K_{fert} the fertilizer K. N_{min} is determined from soil total N (N_{tot}), the annual relative mineralization rate (M) estimated at 3% (Nye and Greenland 1960), and N_{tot} is 1.1%; then in the top 30 cm soil. We assumed that fertilizer N is brought to the system through litter fall and K through litter fall and ash. Exchangeable K was 48.1 kg ha⁻¹ for essep, and 49.4 kg ha⁻¹ for afup. Nye and Greenland (1960) estimated K content of ash from forest and short fallow burning to 56.6 and 27 kg ha⁻¹, respectively. In our study we considered 20 ha afup and 23.2 ha essep. Gaseous losses from the soil (OUT4a). The annual loss of N is related to N_{min} , N_{fert} and the percentage of denitrified N (DN).

$$\text{OUT4a (N)} = \% \text{DN} * (\text{N}_{\text{min}} + \text{N}_{\text{fert}})$$

where DN is a function of clay content of the soil, and the annual rainfall (p), through the transfer function (Smaling et al. 1993):

$$\text{DN}(\%) = -9.4 + 0.13 * \% \text{clay} + 0.01 p$$

Gaseous losses from animal manure (OUT4b). Farmers did not collect animal manure, and we had no hard data to quantify this nutrient loss from the system. Therefore, gaseous losses from animal manure were set to zero although in reality, volatilisation is not negligible especially from urine voided in the field.

Gaseous losses from the burning of the natural vegetation (OUT4c). Losses from burning of the forest vegetation are estimated at 189.6 kg N, 7.4 kg P and 52.2 kg K kg ha⁻¹ year⁻¹ and for the short fallow at 67.3 kg N, 2.4 kg P and 25 kg K ha⁻¹ year⁻¹ Nye and Greenland 1960; Hölscher et al. 1997). Losses of nutrient (X) during burning from the forest and short fallow was estimated as:

$$\text{OUT4c (X)} = [(\text{S}_{\text{afup}} * \text{QX}_{\text{f}}) + (\text{S}_{\text{essep}} * \text{QX}_{\text{F}})] * [F]^{-1}$$

where S_{afup} and S_{essep} are the land area under afup owondo and essep, respectively, QX_{f} the loss from fallow, QX_{F} the loss from forest.

Losses from erosion (OUT5). Erosion was considered negligible in the humid lowland characterizing the study site.

Nutrient balance

Partial nutrient balances were determined at farm level comprising flows over the farm gate:

$$\begin{aligned} \text{Partial budget}_1 = & (\text{IN1} + \text{IN2a} + \text{IN2b} + \text{IN2c}) \\ & - (\text{OUT1a} + \text{OUT1b} + \text{OUT2a} \\ & + \text{OUT2b} + \text{OUT4b} + \text{OUT6}). \end{aligned}$$

Another partial budget was determined with only environmentally controlled flows:

$$\begin{aligned} \text{Partial budget}_2 = & (\text{IN3} + \text{IN4} + \text{IN5} + \text{IN6}) \\ & - (\text{OUT3} + \text{OUT4a} + \text{OUT4c} \\ & + \text{OUT5}). \end{aligned}$$

The total budget was then determined as partial budget₁ + partial budget₂, representing nutrient flows entering or leaving the farm. Different management scenarios were then formulated, to identify strategies for system improvement.

Results

The codes used for the different flows in this study are similar to those defined by Smaling et al. (1996) and Van den Bosch et al. (1998).

*Nutrients managed by farmers**Inorganic fertilizers (IN1)*

No farmer in the study used mineral fertilizers. Farmers depend solely on fallowing and burning of the vegetation to improve the soil fertility, which is the cheapest alternative to mineral fertilizers.

Animal feeds (IN2a)

None of the household surveyed used external feed for farm animals. Pigs, sheep, goats and poultry roam freely with no additional care. They feed on household waste, and/or road side vegetation.

Organic fertilizers (IN2b)

No farmer during the survey reported use of animal manure, compost, kitchen residue or any other organic residue for soil fertility improvement. In

the cocoa plantations, farmers rely on soil fertility-indicating/improving tree species and litter fall from shade trees to maintain the soil fertility.

Wood/charcoal from the forest for cooking (IN2c)

Wood/charcoal from the forest for cooking was estimated from the quantity of wood ash produced by the household. An average of 205 kg of wood ash was produced per household, the nutrient equivalent was 1.6 kg P and 15.6 kg K ha⁻¹ year⁻¹.

Crop products sold or donated (OUT1a)

Crop species monitored included one from essep (ngon), two from banana farm (plantain and banana), 13 from afup owondo, and 12 from the cocoa plantation. The different crop products leaving the farm as sales and gifts and their nutrient equivalent are presented in Table 3. Crop products sold or donated accounted for export of 9.5 kg N, 2.0 kg P, and 9.8 kg K ha⁻¹ year⁻¹.

Animal products sold or donated (OUT1b)

Farm animal groups were pigs, poultry, sheep and goats. The total production of the 20 households, the quantities exported and their nutrient (N, P, K) equivalents are given in Table 4. The nutrient equivalents of animal products leaving the farm were 0.53 kg N, 0.18 kg P, and 0.04 kg K ha⁻¹ year⁻¹.

Nutrient loss in human faeces (OUT6)

The total nutrient contents in the food products eaten by the household annually were 6.6 kg N, 2.0 kg P and 9.2 kg K ha⁻¹ year⁻¹ (Figure 2), out of which 1.9 kg N, 1.2 kg P and 3.2 kg K ha⁻¹ year⁻¹ were returned in the household waste and added to wood ash (Table 5). Nutrient loss in human faeces was 3.9 kg N, 0.64 kg P and 4.8 kg K ha⁻¹ year⁻¹.

The following flows were considered to be zero: Crop residues leaving the farm (OUT2a), animal manure leaving the farm (OUT2b), and gaseous losses from animal manure (OUT4b).

*Internal nutrient flows**Feed for farm animals (F11)*

No farmer reported the use of feed for farm animals.

Table 3. Destination of crop products in a smallholder farming system of the Campo Ma'an area, southern Cameroon (kg household⁻¹ year⁻¹).

Farm section	Crop products	Total Products (a + b)	Sales and gifts OUT1a (a)	Household consumption Fl6 (b)	Total household waste F12 (c+d)	Animal feed Fl2a (c)	Decomposed waste Fl2b (d)
Essep (1.16 ha)	<i>Ngon</i>	189	154	35.4	0	0	0
Banana farm (0.4 ha)	Banana	525	139	386	222	187	34.5
	Plantain	1918	978	940	459	318	141
Afup owondo 1.0 ha)	Groundnut	276	123	153	43.3	3.0	40.3
	Cassava	6237	2716	3521	886	775.5	111
	Maize	508	123	385	205	54.8	150
	Cocoyam	845	515	330	127	1.9	125
	Sweet potatoes	208	39.9	168	39.6	39.6	0
	Yam	137	25.2	112	15.3	14.3	1.0
	Sugar cane	670	281	388	180	120	60.4
	Pepper	12.7	5.0	7.7	0.60	0	0.6
	Tomatoes	64.7	22.6	42.2	0.10	0	0.1
	<i>Okra</i>	29.6	2.0	27.6	0	0	0
	Beans	3.2	0	3.2	2.2	0.1	2.1
	<i>Djinja</i>	2.1	0	2.1	0	0	0
	Onions	1.7	0	1.7	0	0	0
	Cocoa farm (3.5 ha)	Cocoa	593	593	0	0	0
Guava		121	80.2	41.1	0	0	0
Cola		8.4	5.5	2.9	0	0	0
<i>Andok</i>		71.1	42.8	28.3	0	0	0
Citrus		177	102	75.4	52.3	0	52.3
<i>Safou</i>		176	62.8	112.9	35.6	2.5	33.1
Papaw		70.7	22.4	48.3	0	0	0
Pear		1245	534	711	161	1.6	159
Palm oil		779	421	358	312	60.8	252
Coco nut		105	67.8	37.7	28.2	0	28.2
Mangoes		11.2	3	8.3	0	0	0
<i>Casmango</i>	173	86.4	86.4	0	0	0	

Table 4. Animal products and nutrient (N, P, K) equivalents in traditional land uses of Campo Ma'an, southern Cameroon.

Animal groups	Total ^a (kg)	Sales and gifts (OUT1b) (kg year ⁻¹)				Household consumption (Fl6b) (kg)			
		Products	N	P	K	Products	N	P	K
Pigs	4539	2575	25.7	12.9	2.6	1964	19.6	9.8	2.0
Poultry	895	302	9.1	1.8	0.30	593	17.8	3.6	0.59
Sheeps and goats	1578	1138	28.4	6.8	2.3	440	11.0	2.6	0.88
Mean (kg ha ⁻¹ year ⁻¹)			0.53	0.18	0.04		0.40	0.13	0.03

^aTotal of 20 households.

Nutrient transfer from the household to household waste (Fl2)

It was estimated that 1.9 kg N, 1.2 kg P and 3.2 kg K ha⁻¹ year⁻¹ is transferred from the household to the waste, as food remains that can be consumed by animals. By including nutrient from the wood ash (1.59 kg P and 15.6 kg K ha⁻¹ year⁻¹), total nutrients in the kitchen household waste are 1.9 kg N, 2.79 kg P and 18.8 kg K ha⁻¹ year⁻¹.

Animal consumption of household waste (Fl2a)

Farm animals annually recycle from the household waste 0.7 kg N, 0.6 kg P and 1.6 kg K per ha of total farm area.

Decomposition of household waste (Fl2b)

The difference between nutrients transferred to household waste, and nutrients recycled by farm animals is 1.1 kg N, 2.2 kg P and 17.2 kg K ha⁻¹

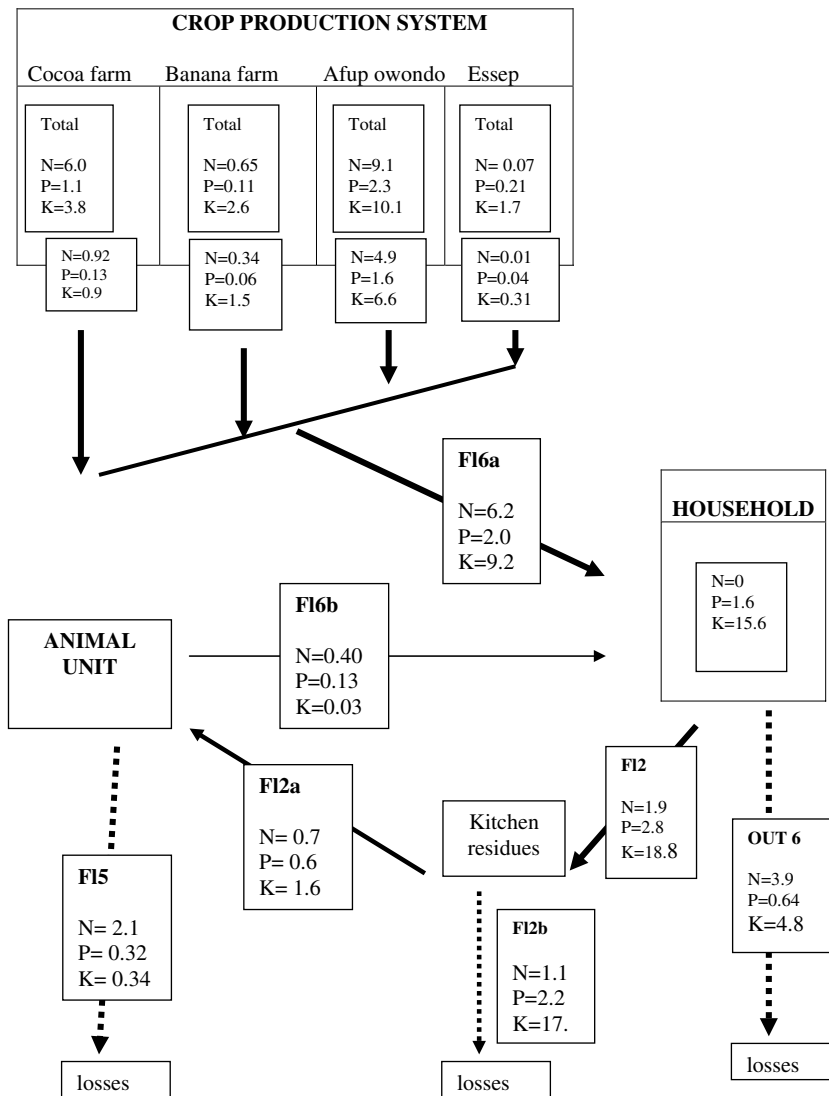

Figure 2. Internal nutrient flows in a traditional farming system of southern Cameroon.

year⁻¹, accumulating in household waste and thus lost from the system.

Nutrient transfer in crop residues within the crop unit (F13)

Transfer of crop residues was not recorded in the course of this study.

Browsing animals (F14)

Animal browsing from roadside vegetation was estimated as 1.25*F15, equivalent to 6.1 kg N, 0.5 kg P and 2 kg K ha⁻¹ year⁻¹.

Production of manure by the farm animals (F15a)
Farm animals excreted 2.1 kg N, 0.32 kg P and 0.34 kg K ha⁻¹ year⁻¹ in manure (Table 6).

Crop products eaten by the household (F16a)
From the farm products used for family consumption, the estimated quantity of nutrients was 6.2 kg N, 1.9 kg P and 9.2 kg K ha⁻¹ year⁻¹. High K value products such as cassava and leafy legumes are the staple food. Products with high N contents such as cocoa and groundnuts are mostly sold.

Table 5. Nutrient export and destination through crop products in the traditional farming systems of the Campo Ma'an area, southern Cameroon.

		Farm sections				
		Essep (1.16 ha)	Banana (0.4 ha)	Afup (1.0 ha)	Cocoa (3.5 ha)	Total (kg ha ⁻¹)
<i>Total production</i>						
N	0.42		3.99	55.3	36.5	15.8
P	1.3		0.7	14.7	6.8	3.7
K	10.2		15.9	61.3	23.1	18.1
<i>Sales and gifts (OUT1a)</i>						
N	0.34		1.8	25.2	30.8	9.5
P	1.1		0.34	4.7	6.6	2.0
K	8.3		7.0	27.3	17.6	9.8
<i>Household consumption (Fl6b)</i>						
N	0.08		2.1	30.1	5.6	6.2
P	0.25		0.4	9.9	0.8	1.9
K	1.9		8.9	40.0	5.5	9.2
<i>Household waste (Fl2)</i>						
N	0		0.9	8.1	2.3	1.9
P	0		0.2	6.8	0.3	1.2
K	0		5.6	10.7	2.9	3.2
<i>Animal feed from the waste (Fl2a)</i>						
N	0		0.7	3.6	0.2	0.7
P	0		0.2	3.0	0.04	0.6
K	0		4.3	5.3	0.2	1.6
<i>Residues (Fl2b)</i>						
N	0		0.2	4.6	2.1	1.1
P	0		0.05	0.8	0.2	0.8
K	0		1.3	5.5	2.7	1.6

Table 6. Production of manure by farm animals and nutrient (N, P, K) equivalents, in the Campo Ma'an area, southern Cameroon.

Animal groups	Live weight (kg)	Manure produced (kg)	Concentration (g kg ⁻¹ manure)			Nutrient equivalent in animal manure (kg year ⁻¹)		
			N	P	K	N	P	K
Pigs	1149	2896	2.5	0.48	0.65	72.4	13.9	18.8
Chicken	210	1286	2.2	0.37	0.20	28.3	4.8	2.6
Ducks	63.3	450	0.95	0.01	0.16	4.3	0.04	0.72
Sheeps	567	2649	3.2	0.32	0.40	84.8	8.5	10.6
Goats	367	1717	3.8	0.67	0.50	65.5	11.5	8.6
Total	2357	8997				255	39	41
Mean (Fl5a) (kg ha ⁻¹ year ⁻¹)						2.1	0.32	0.34

Animal products used for food (Fl6b)

From the animal products used for family consumption, the estimated quantity of nutrients was 0.4 kg N, 0.13 kg P and 0.03 kg K ha⁻¹ year⁻¹.

Nutrient inputs not controlled by farmers

Atmospheric deposition (IN3)

With annual rainfall of 1900 mm, deposition was estimated at 4.35 kg N, 1 kg P and 3.92 kg K ha⁻¹ year⁻¹.

Biological nitrogen fixation (IN4)

$$\begin{aligned} \text{IN4 (N)} &= [(20 \times 17.84) + (100 \times 4.75)][120]^{-1} \\ &= 6.93 \text{ kg ha}^{-1} \text{ year}^{-1} \end{aligned}$$

Deep capture (IN6)

Annual litter fall in the production systems was 5t/ha, and the equivalent nutrient input is 66.4 kg N, 5.15 kg P and 26.2 kg K ha⁻¹ year⁻¹.

We then estimated IN6 as 16.6 kg N, 1.38 kg P, and 6.55 kg K ha⁻¹ year⁻¹.

Nutrient outputs not controlled by farmers

Nutrient loss through leaching (OUT3)

$$\begin{aligned} \text{OUT3a(N)} &= 66 \times (2.1 \times 10^{-2} \times 1900 + 3.9) \\ &= 26.37 \text{ kg ha}^{-1} \text{ year}^{-1} \end{aligned}$$

$$\begin{aligned} K_{\text{fert}} &= [(27 \times 20) + (56.6 \times 23.2)][20 + 23.2]^{-1} \\ &= 42.9 \text{ kg ha}^{-1} \text{ year}^{-1} \end{aligned}$$

$$\begin{aligned} \text{OUT3a (K)} &= (48.7 + 42.9) \times (2.9 \times 10^{-4} \times 1900 \\ &\quad + 0.41) \times 0.01 = 0.88 \text{ kg ha}^{-1} \text{ year}^{-1} \end{aligned}$$

Gaseous losses from the soil (OUT4a)

$$\begin{aligned} \text{OUT4a (N)} &= (N_{\text{min.}} + N_{\text{fert}})(-9.4 + 0.13 \times 0.22 \\ &\quad + 0.01 \times 1900) = 66 \times 0.096 \\ &= 6.34 \text{ kg ha}^{-1} \text{ year}^{-1} \end{aligned}$$

Gaseous losses through burning of the natural vegetation (OUT4C)

$$\text{OUT4c (N)} = [(20 \times 67.3) + (23.2 \times 189.6)][120]^{-1} = 47.8$$

$$\text{OUT4c (P)} = [(20 \times 2.4) + (23.2 \times 7.42)][120]^{-1} = 1.83$$

$$\text{OUT4c (K)} = [(20 \times 25) + (23.2 \times 52.2)][120]^{-1} = 14.25$$

Therefore, losses through burning of the natural vegetation is estimated at 47.8 kg N, 1.8 kg P and 14.2 kg K ha⁻¹ year⁻¹.

Partial budget of flows managed by farmers

The balance of nutrients managed by farmers is -65 kg N, -5.5 kg P and -30.8 kg K ha⁻¹ year⁻¹ (Table 7). Burning during land preparation accounts for 70% of N, 25% of P and 30% of K losses. No input is brought into the farm, except for firewood, and a considerable quantities of nutrients are exported in crop products leaving the farm. There is a high export of K, compared to N and P. Most of the K in sold products comes from the afup owondo, 4.8 kg, 1.36 from essep and 1.15 kg from the banana farm. In terms of crops, each household exports 11.4 kg in cocoa, 8.30 kg

Table 7. Farm-level nutrient budgets in traditional systems of southern Cameroon. (kg ha⁻¹ year⁻¹)

Type of flows		N	P	K
<i>Farmer managed</i>				
IN1:	Mineral fertilizers	0	0	0
IN2a:	Animal feeds	0	0	0
IN2b:	Organic fertilizers	0	0	0
IN2c:	Fuel wood	0	1.6	15.6
FI5	Losses from animal manure	2.1	0.32	0.34
FI2c:	Losses from household waste	1.1	2.2	17.2
OUT1a:	Crop products sold	9.5	2.0	9.8
OUT1b:	Animal products sold	0.53	0.18	0.04
OUT2a:	Export of crop residues	0	0	0
OUT2b:	Animal manure leaving the farm	0	0	0
OUT4c:	Gaseous losses from burning	47.8	1.8	14.3
OUT6:	Human faeces	4.0	0.64	4.8
Partial budget 1		-65	-5.5	-30.8
<i>Not farmer managed</i>				
IN3:	Atmospheric deposition	4.4	1	3.9
IN4:	Biological N fixation	6.9	0	0
IN5:	Sedimentation	0	0	0
IN6:	Deep capture	16.6	1.4	6.6
OUT3a:	Leaching	26.4	0	1.0
OUT4a:	Gaseous losses from the soil	6.3	0	0
OUT5:	Water erosion	0	0	0
Partial budget		-4.8	+2.4	+9.5
Total budget		-69.8	-3.1	-21.3

in ngon, and 8.23 kg in plantain. Most of the nutrients consumed by the household originate from the afup owondo, 4.93 kg N, 1.62 P and 6.56 K (Figure 2).

Partial budget of flows not managed by farmers

Table 7 indicates a balance of -4.8 kg N, $+2.4$ kg P and $+9.6$ kg K ha^{-1} year^{-1} , for nutrient flows not managed by farmers. The major input is through deep capture by trees; farmers maintain many trees especially in cocoa farms as shade trees, which significantly contribute to nutrient recycling in the system. Despite the absence fertilizer input, cocoa fields are sustainable through recycling by the trees and the high litter production. Main losses originate from burning of the vegetation, either directly through volatilisation, or indirectly through leaching.

Total farm nutrient budget and scenario results

Figure 3 summarizes the major nutrient inflows and outflows of the system. The total budgets (Table 7) of the farming system are negative: -69.8 kg N, -3.1 kg P and -21.3 kg K ha^{-1} year^{-1} . The deficit in nitrogen results mostly from volatilisation during burning and that of K from non-recycled household waste and animal manure. Recycling household waste, animal manure and even human faeces could be envisaged as management options to improve the nutrient balance. To explore the options for improvements in the system, six management scenarios have been formulated (Table 8): (S1) the actual management system is maintained, the nutrient (N, P, K) balance (kg ha^{-1} year^{-1}) are $(-69.8, -3.1, -21.3)$; (S2) household waste and animal manure are recycled (balance: $-66.6, -0.62, -3.8$). If the human faeces are also recycled (S3) the balance will be: $-62.6, 0, +1$. If burning is avoided and the actual management level maintained (S4), the budget will be: $+4.4, -1.3, -6.1$. Two scenarios resulted in completely positive nutrient balances: no burning and recycling of household waste and animal manure (S5), with balances of: $+7.6, +1.2, +1.5$, and no burning and all residues recycled (S6): $+11.6, +1.82, +16.2$.

Discussion and conclusions

Farm level results

Previous work on nutrient budgets has targeted densely populated and agriculturally intensive areas, where farmers invest in soil fertility improvement. Organic and chemical amendments, household residues and crop residues are actively recycled and redistributed in the different production compartments (Smaling et al. 1993; Bajjukya and De Steenhuijsen Pieters 1998; Hoffmann et al. 2001). The system investigated in this study is structurally different, as burning and fallowing are the sole mechanisms for soil fertility management, resulting in extremely "depletive" cropping system. As there is no addition of nutrients from outside the system, it survives on natural soil fertility. In the forest zone, the animal component is small and poorly documented; farmers do not actively redistribute animal manure in the farm. In northwest Nigeria farmers combine application of organic and mineral fertilizers in an effective way to maintain the fertility of their soils, adding annually 87 kg N, 33 kg P, and 120 kg K ha^{-1} (Hoffmann et al. 2001). In cattle producing areas in North West Tanzania, animal manure redistributes 68 kg N, 15 kg P and 56 kg K ha^{-1} year^{-1} (Bajjukya and De Steenhuijsen Pieters 1998). Inputs of 44 kg N, 23 kg P and 11 kg K ha^{-1} year^{-1} as inorganic fertilizers have also been reported in the sub-humid zone of Kenya (Van den Bosch et al. 1998). Many African countries have removed subsidies on fertilizers and they are no longer available or smallholders cannot afford them. Nutrient flows not directly managed by farmers, and estimated from transfer functions are generally site-specific, depending on rainfall and soil texture. Very little information is available for the humid forest zone. However, most of the nutrient flows calculated in this study were similar to those reported for the humid forest of Ivory Coast (Janssen et al. 1990), humid Amazonian forest (Hölscher et al. 1997), and the humid savannas of eastern Africa (Smaling et al. 1993; Van den Bosch et al. 1998).

Animal production is small-scale probably because of limited animal feed (Table 6), resulting in low production of manure compared to the savannah. The only external input into the system by farmers was fuel wood. Substantial losses

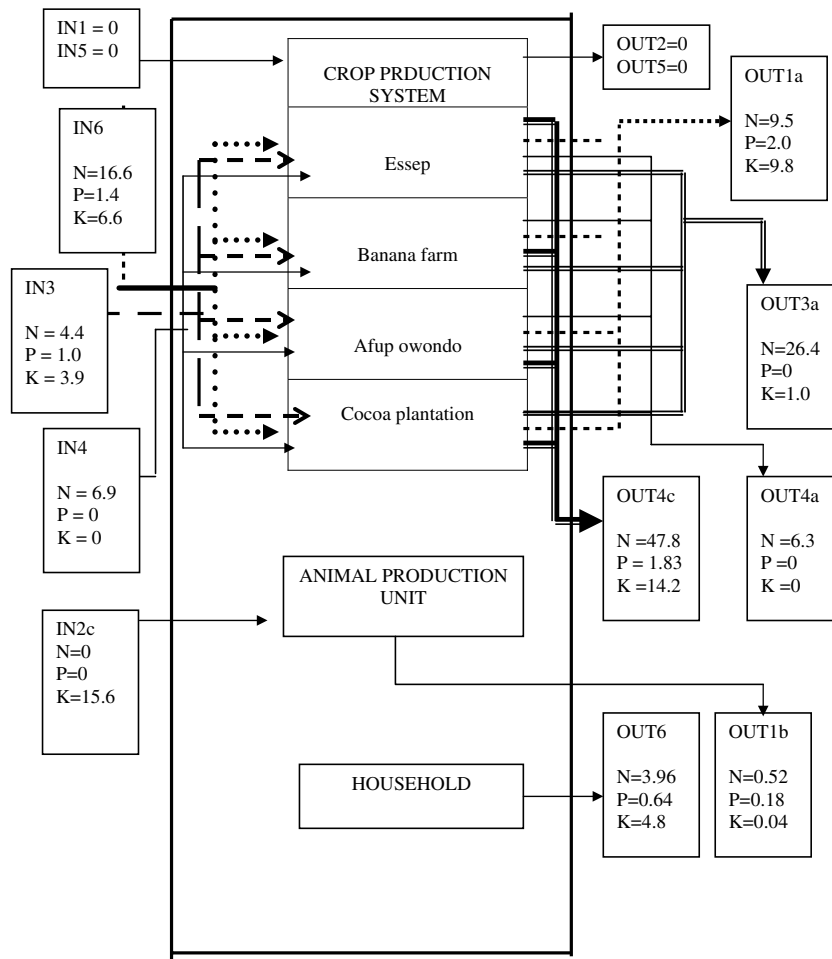

Figure 3. Inflows and outflows of nutrients in a traditional farming system of southern Cameroon.

through burning, leaching, non-recycled household waste and animal manure could not be balanced by nutrient inputs though natural processes. The system thus shows negative nutrient balances: -70 kg N , -3 kg P and $-21 \text{ kg K ha}^{-1} \text{ year}^{-1}$. Main losses occurred from burning and leaching. Nutrient export in crop products represented 14% of N, 45% of P and 25% of K. Main inputs into the cocoa system are through deep capture.

Subsystem level results

Table 9 compares nutrient budgets in the different land uses. We assumed that because of very few trees maintained in essep, banana and afup, deep capture in those farming system components is

negligible. In cocoa, farmers maintained a large number of trees that prevent nutrient leaching, and act as “pumps” for deep capture of nutrients. We also assumed that the presence of these trees in cocoa reduced leaching by 75%. Major inflows into the four sub-systems are atmospheric depositions and biological N fixation. Nutrient balances in essep and afup were negative, with high N and K deficits. Major losses in essep and afup were through burning. In banana however, the P and K balance were positive. Nutrient balances in the cocoa plantation were positive: 9.3 kg N , 1.4 kg P and $7.6 \text{ kg K ha}^{-1} \text{ year}^{-1}$. Cocoa can therefore be considered as a sustainable system in terms of nutrient balances. The nutrient balance in banana is positive for K: $+1.9 \text{ kg ha}^{-1} \text{ year}^{-1}$. Table 5 indicates banana production requires 39.8 kg of

Table 8. Total nutrient balance for different management scenarios in the slash and burn agricultural system in southern Cameroon. (kg ha⁻¹ year⁻¹)

Flows	Management scenario ^a														
	S2			S3			S4			S5			S6		
	N	P	K	N	P	K	N	P	K	N	P	K	N	P	K
<i>Inflows</i>															
IN1: Mineral fertilizers	0	0	0	0	0	0	0	0	0	0	0	0	0	0	0
IN2a: Animal feeds	0	0	0	0	0	0	0	0	0	0	0	0	0	0	0
IN2b: Organic fertilizers	0	0	0	0	0	0	0	0	0	0	0	0	0	0	0
IN2c: Fuel wood	0	1.6	15.6	0	1.6	15.6	0	1.6	15.6	0	1.6	15.6	0	1.6	15.6
IN 3: Atmospheric depositions	4.4	1	3.9	4.4	1	3.9	4.4	1	3.9	4.4	1	3.9	4.4	1	3.9
IN 4: Biological N fixation	6.9	0	0	6.9	0	0	6.9	0	0	6.9	0	0	6.9	0	0
IN 5: Sedimentation	0	0	0	0	0	0	0	0	0	0	0	0	0	0	0
IN 6: Deep capture	16.6	1.4	6.6	16.6	1.4	6.6	16.6	1.4	6.6	16.6	1.4	6.6	16.6	1.4	6.6
Total Inflows	27.9	4	26.1	27.9	4	26.1	27.9	4	26.1	27.9	4	26.1	27.9	4	26.1
<i>Outflows</i>															
OUT 1a: Crop products sold	9.5	2	9.8	9.5	2	9.8	9.5	2	9.8	9.5	2	9.8	9.5	2	9.8
OUT 1b: Animal products sold	0.53	0.18	0.04	0.53	0.18	0.04	0.53	0.18	0.04	0.53	0.18	0.04	0.53	0.18	0.04
OUT 2a: Export of crop residues	0	0	0	0	0	0	0	0	0	0	0	0	0	0	0
OUT 3a: Leaching	26.4	0	1.0	26.4	0	1.0	0	0	0	0	0	0	0	0	0
OUT 4a: Gaseous losses from soil	6.3	0	0	6.3	0	0	6.3	0	0	6.3	0	0	6.3	0	0
OUT 4c: Gaseous losses from burning	47.8	1.8	14.3	47.8	1.8	14.3	0	0	0	0	0	0	0	0	0
OUT 5: Erosion	0	0	0	0	0	0	0	0	0	0	0	0	0	0	0
OUT 6: Human faeces	4	0.64	4.8	0	0	0	4	0.64	4.8	4	0.64	4.8	0	0	0
Fl5: Losses from animal manure	0	0	0	0	0	0	2.1	0.32	0.34	0	0	0	0	0	0
Fl2c: Losses from household waste	0	0	0	0	0	0	1.1	2.2	17.2	0	0	0	0	0	0
Total outflows	94.5	4.62	29.9	90.5	4.0	25.1	23.5	5.3	32.1	20.3	2.8	14.6	16.3	2.18	9.8
Balance	-66.6	-0.62	-3.8	-62.6	0	+1	+4.4	-1.3	-6.1	+7.6	+1.2	+1.5	+11.6	+1.82	+16.2

^a S1: Actual balance, see Table 7.

S2: household waste and animal manure recycled.

S3: S2 plus human faeces recycled.

S4: Actual management, but burning avoided.

S5: No burning + S2.

S6: No burning + S3.

K ha⁻¹, which is less than K requirements of afup (61.3 kg ha⁻¹). Banana is the staple food, and 56% of the crop is used for household consumption. The area under banana represents only 6% of the total farm area. The small production scale and the high internal recycling explain the positive K balance in banana. Market-oriented intensification of banana production would rapidly lead to negative K balance, unless amendments are provided.

In afup and essep 74 and 76 kg N ha⁻¹ are lost annually, respectively. Introduction of nitrogen-fixing tree species in essep and afup as planted fallow might be a suitable technological innovation to remedy the N depletion in the system, provided adequate residue management is developed to avoid losses during land preparation. Most of the household nutrients supply is from the essep: 4.9 kg N, 1.6 kg P and 6.6 kg K ha⁻¹year⁻¹. However, from the total nutrients supply to the household, 60% of

Table 9. Nutrient budgets in the different land use system components of the slash and burn chronosequence in southern Cameroon (kg ha⁻¹ year⁻¹).

Flows	Land uses											
	Essep			Banana			Afup			Cocoa		
	N	P	K	N	P	K	N	P	K	N	P	K
<i>Inflows</i>												
IN1: Mineral fertilizers	0	0	0	0	0	0	0	0	0	0	0	0
IN2a: Animal feeds	0	0	0	0	0	0	0	0	0	0	0	0
IN2b: Organic fertilizers	0	0	0	0	0	0	0	0	0	0	0	0
IN2c: Fuel wood	0	0	0	0	0	0	0	0	0	0	0	0
IN3: Atmospheric deposition	4.4	1	3.9	4.4	1	3.9	4.4	1	3.9	4.4	1	3.9
IN4: Biological N fixation	0	0	0	0	0	0	6.9	0	0	0	0	0
IN5: Sedimentation	0	0	0	0	0	0	0	0	0	0	0	0
IN6: Deep capture	0	0	0	0	0	0	0	0	0	16.6	1.4	6.6
Total Inflows	4.4	1.0	3.9	4.4	1.0	3.9	11.3	1.0	3.9	21	2.4	10.5
<i>Outflows</i>												
OUT1a: Crop products sold	0.06	0.17	1.39	0.31	0.05	1.1	4.2	0.7	3.5	5.1	0.97	2.9
OUT1b: Animal products sold	0	0	0	0	0	0	0	0	0	0	0	0
OU 2a: Export of crop residues	0	0	0	0	0	0	0	0	0	0	0	0
OU 3a: Leaching	26.4	0	0.88	26.4	0	0.88	26.4	0	0.88	6.6	0	0.20
OUT4a: Gaseous losses from soil	6.6	0	0	6.6	0	0	6.6	0	0	6.6	0	0
OUT4c: Gaseous losses from burning	47.8	1.8	14.3	0	0	0	47.8	1.8	14.3	0	0	0
OUT6: Human faeces	0	0	0	0	0	0	0	0	0	0	0	0
Total outflows	80.9	1.97	16.6	33.3	0.05	2.0	85.0	2.5	18.6	11.7	0.97	2.9
Balance	-76.5	-0.97	-12.7	-28.9	+0.95	+1.9	-73.7	-1.5	-14.7	+9.3	+1.43	+7.6

N, 32% of P and 52% of K are lost in deep latrines. Large quantities of K enter household waste through wood ash, but are recycled.

Management scenarios

Recycling household waste, animal manure and/or human faeces, and the abolishment of burning could significantly modify the nutrient balances of the system. From the management scenarios proposed (Table 8), scenarios S2 and S3 are feasible, without major difficulties; in densely populated areas of western Cameroon, human faeces are recycled as feeds for pigs, or used as organic manure. The major challenge in the system will be to reduce burning during land preparation, which is necessary to achieve a positive nutrient balance. Farmers cannot avoid burning in essep and afup, and cannot do without afup, since it is the main source of food for the household. Completely avoiding burning is therefore difficult. The trade-off will be to reduce farmer dependence on essep and afup as sources of income, and develop alternative tree-based systems with high income generating potentials. The strategy might involve enriching cocoa plantations with fruit and medic-

inal tree species of high commercial value, i.e. reducing essep and afup at household consumption scale, and developing tree-based systems at commercial scale.

Acknowledgements

This study was funded by Tropenbos International, through the GEF/World Bank-funded Campo Ma'an Project. We are indebted to many farmers in Messama, Asseng, Mvi'llimengale and Ma'an-village who allowed us to collect data and sometimes embarrassing samples from their farms, kitchens and garbage heaps.

References

- Anderson J.M. and Ingram J.S.I. 1993. Tropical Soil Biology and Fertility: A Handbook of Methods. CAB International, Oxon, UK.
- Bajjukya F.P. and De Steenhuijsen P.B. 1998. Nutrient balances and their consequences in the banana based land use systems of Bukoba district, North West Tanzania. *Agricult. Ecosyst. Environ.* 71: 147–158.
- Barrow N.J. 1987. Return of nutrients by animals. In: Synadon R.W. (ed.), *Managed Grasslands*. Oxford, Elsevier.

- Bationo A., Lompo F. and Koala S. 1998. Research on nutrient flows and balances in west Africa: state-of-the-art. *Agricult. Ecosyst. Environ.* 1: 19–35.
- Büttner U. and Hauser S. 2003. Farmer's nutrient management practices in indigenous cropping systems in southern Cameroon. *Agricult. Ecosyst. Environ.* 100(2–3): 103–110.
- Deugd M., Roling N. and Smaling E.M.A. 1998. A new praxeology for integrated nutrient management, facilitating innovation with and by farmers. *Agricult. Ecosyst. Environ.* 71: 269–283.
- Haynes R.J. and Williams P.H. 1993. Nutrient cycling and soil fertility in grazed pasture ecosystems. *Adv. Agronom.* 49: 119–199.
- Hoffman I., Gerling D., Kyogwom U.B. and Mane-Bielfeldt 2001. Farmers' management strategies to maintain soil fertility in a remote area in northwest Nigeria. *Agricult. Ecosyst. Environ.* 86(3): 263–275.
- Hölscher D., Möller R.F., Denich M. and Fölster H. 1997. Nutrients input–output budget of shifting cultivation in Eastern Amazonia. *Nutrient Cycling Agroecosyst.* 47: 49–57.
- Janssen B.H., Noij I.G.A.M., Wesselink L.G. and Van Grinsven J.J.M. 1990. Stimulation of the dynamics of nutrients and moisture in tropical ecosystems. *Fert. Res.* 26: 145–156.
- Juo A.S.R. and Manu A. 1996. Chemical dynamics in slash-and-burn agriculture. *Agricult. Ecosyst. Environ.* 58: 49–60.
- Kotto-Same J., Woomer P.L., Moukam A. and Zapfack L. 1997. Carbon dynamics in slash-and-burn agriculture, and land-use alternatives of the humid forest zone in Cameroon. *Agricult. Ecosyst. Environ.* 65(3): 245–256.
- Nye P.H. and Greenland D.J. 1960. The soil under shifting cultivation. Technical Communication 51, Commonwealth Bureau of Soil, Harpenden, UK.
- Oenema O., Kros H. and de Vries W. 2003. Approaches and uncertainties in nutrient budgets: implications for nutrient management and environmental policies. *Eur. J. Agron.* 20: 3–16.
- Sanginga N., Lyasse O., Diels J. and Merckx R. 2003. Balanced nutrient management systems for cropping systems in the tropics: from concept to practice. *Agricult. Ecosyst. Environ.* 100(2–3): 99–102.
- Smaling E.M.A. 1993. An Agroecological Framework for Integrated Nutrient Management with Special Reference to Kenya. Wageningen Agricultural University, Wageningen, The Netherlands, (Ph.D. thesis).
- Smaling E.M.A., Stoorvogel J.J. and Windmeijer P.N. 1993. Calculating soil nutrient balances in Africa at different scales. II District scale. *Fert. Res.* 35: 237–250.
- Smaling E.M.A., Fresco L.O. and de Jager A. 1996. Classifying, monitoring and improving soil nutrient stocks and flows in Africa agriculture. *Ambio* 25(8): 492–496.
- Stoorvogel J.J. and Smaling E.M.A. 1990. Assessment of soil nutrient depletion in sub-Saharan Africa, 1983–2000. Report 28. The Winand Centre for Integrated Land, Soil and Water Research (SC-DLO) Wageningen.
- Szott L.T. 1995. Growth and biomass production of nitrogen fixing trees on acid soils. In: Evans D.O. and Szott L.T. (eds), *Nitrogen Fixing Trees for Acid Soils*. Proceedings of a workshop organized by NTFA and CATIE held in Costa Rica July 3–8 1994 in Turrialba, USA, NFT Research Report Arkansas.
- Tchoumboue J. 1980. Rôle des déjections animales dans la pollution de l'environnement. Animation Scientifique, Département de Zootechnie, ENSA Yaoundé.
- Van Den Bosch H., Gitari J.N., Ogaro V.M., Maobe S. and Vlaming J. 1998. Monitoring nutrient flows and economic performance in Africa farming systems (NUTMON). III. Monitoring nutrient flows and balances in the districts in Kenya. *Agric Ecosyst. Environ.* 71: 63–80.
- Westphal E., Embrechts J., Mbouemboue P. Mouzong Boyomoet and Westphal-stevens J. M.C. 1981. *l'Agriculture autochtone au Cameroun: les techniques culturelles, les séquences de culture, les plantes alimentaires et leur consommation*, Miscellaneous papers 20 Landbouwhogeschool Wageningen, The Netherlands.

Management of improved fallows for soil fertility enhancement in the western highlands of Cameroon

Meppe F.^{1,*}, Bilong P.² and Nwaga D.³

¹ Institute of Agricultural Research for Development, (IRAD), Box 2067, Yaoundé, Cameroon, e-mail: pacomep2000@yahoo.com (*Corresponding author); ² Faculty of Sciences, University of Douala I, Cameroon; ³ Plant Biology Department, Faculty of Science, University of Yaounde I, Cameroon

Abstract

A fallow management experiment was initiated at Mfonta and Babungo to identify a suitable method of incorporating *Crotalaria juncea* and *Tephrosia vogelii* as green manures into maize cropping systems. Experimental designs were randomized complete block (RCB) with a split plot treatment arrangement the first year and RCB the subsequent years. Each legume species was either planted alone, simultaneously with maize at planting or relayed both 45 days after planting and at the silking growth stage. In one half each maize plot, below ears were defoliated and in the other part, there was no defoliation. Above plant biomass from legume shrubs was harvested, incorporated into the soil and planted to maize crop the two subsequent years to study the residual effects of treatments and their duration. Results indicated that defoliating maize significantly ($p < 0.05$) increased legume plant height and biomass at both sites. Intercropping maize with legumes resulted in significant ($p < 0.05$) legume biomass and maize yield differences at Mfonta but not at Babungo. Residual effects of green manures in both locations increased maize grain yield compared to the two control treatments. *Tephrosia* intercropped with maize at planting at Mfonta produced the highest residual effects of 67% and 84% higher, respectively, as compared with the two control treatments; While at Babungo the same treatment, with *Crotalaria* generated the highest residual effects of 14% and 74% higher. When the same plots were cropped to maize the third year, yields were much lower at Mfonta and slightly higher at Babungo, indicating that the legume fallows can distinctly sustain the productivity at those study sites.

Key words: Cameroon, *Crotalaria*, improved fallows, maize, soil fertility, *Tephrosia*

Introduction

Most soils in the western highlands of Cameroon (WHC) have low fertility and many tests have indicated that they are deficient in plant nutrients (N, P, Ca, Mg). These soils are moderately acidic ($\text{pH} < 5.5$) Ultisols derived from basalts, trachytes and granites with varying degrees of weathering of parent materials, climate and land use pattern (Van Ranst et al., 1989; 1990; Osiname et al., 1992). Crop yields have declined with continuous cropping.

The zone is one of the most densely populated areas of the country which has led to the over exploitation of

crop lands, reduced levels of soil organic matter, extension of cultivation into marginal areas, drastic reduction of fallow periods from two years to below the minimum threshold required for the system's sustainability (FAO, 1985; Conway, 1997) and soil degradation due to water erosion and low replenishment of plant nutrients. Over the past decades, more farmers have reacted by applying fertilizers to their crops (McHugh and Kikafunda-Twine, 1995). However, with the rising costs of farm inputs, this is becoming less of an option for the majority of smallholders who do not have enough cash to purchase inorganic fertilizers. A practical technological option for improving soil conservation and

management that is economically viable and ecologically sound would be the use of improved fallows.

Improved fallows of nitrogen fixing legumes (NFL) species improve soil fertility in intensified cropping systems (Sanchez and Hailu, 1996; Weber, 1996). Integrated N management can take advantage of biological nitrogen fixation to reduce fertilizer requirements (Greenland, 1985). Improvement of soil fertility through the use of nitrogen fixing legumes is an old practice in developed countries. Plant biomass added to soil results in increased soil organic matter content which contributes to the supply of plant nutrients like nitrogen, phosphorus, potassium, calcium and magnesium, therefore helps small scale farmers save money and fight against poverty.

During the 1987–93 period, the Institute of Agronomic Research (IRA) conducted research on various options for sustaining soil fertility crop production. Investigations initially involved the introduction and evaluation of the potential of using indigenous herbaceous legume crops for improved soil productivity and quantification of nitrogen contribution of the promising legumes. The results of these trials led to the identification of two herbaceous legume species (*Tephrosia vogelii* and *Crotalaria juncea*) as promising candidates for the sustainability of small-scale farming systems (Kikafunda-Twine, 1990; Yamoah and Ngueguim, 1992). These species were selected for a one-year fallow rotation with food crops in the WHC. However, the extent to which these two species are managed under the maize (the people's most important staple food in the region)-based cropping systems is not well understood. Therefore, the objectives of the study were: (1) To determine the effect of maize canopy management on legume plant height, above-ground biomass and maize grain yield, under various periods of legumes/maize associations, (2) To determine the best maize/legumes association that will favor the production of both above-ground biomass and maize grain yield, and, (3) To assess the magnitude and duration of the legume residual effect on maize yield.

Materials and methods

Trial site description

The experiment was carried out during the 1996–98 cropping period at experimental fields of the “Institut

de la Recherche Agronomique (IRA)”, Bambui Station, NW Cameroon at Mfonta (10°17'E and 6° 12'N; 1330 meters above sea level (masl) and Babungo (10° 26'E and 6° 04'N; 1176 masl). The soil at Mfonta is derived from lava basalt and is classified as Typic Kandihumult, and that of Babungo is derived from tertiary basalt and is classified as an Umbric Cambisol (Hof et al., 1987). The areas have a mean annual rainfall of approximately 1900 mm for Bambui and 1200 mm for Babungo. The rainfall distribution is monomodal beginning from March to November with most of rains falling in the month of July, August and September when most crops have matured and often times been harvested (Kikafunda-Twine, 1990). The vegetation present in the areas is grassland of the moist derived Sudan Savanna with abundant grass species. The trial sites were isolated bush fields that had been cropped for several years without organic manure or very little inorganic fertilizer and tilled by hand hoe with very limited incorporation of fallow and crop residues.

Experimental design and treatment

The first year, the experiment at both sites was arranged as a 9 x 2 factorial in a split plot design with 4 replicates. Maize/legume association (cropping systems) (*Tephrosia* sole, *Crotalaria* sole, maize sole (control₁), maize/*Tephrosia* T₁ (planted at the same time as maize), maize/*Crotalaria* T₁, maize/*Tephrosia* T₂ (relayed to maize at 45 days after planting), maize/*Crotalaria* T₂, maize/*Tephrosia* T₃ (relayed to maize at silking), maize/*Crotalaria* T₃) was the main plot (9m x 6m) and maize canopy management (defoliating maize leaves below the ear two weeks after silking (+defoliation) and not defoliating (–defoliation)) the subplots (4.5m x 6m). The sole legume and maize plots were also split and only the latter got the defoliation treatment since it has maize. Natural bush fallow treatment plot (control₂) which is the traditional practice of leaving weeds in place to allow regrowth during the long fallow period (one year) was demarcated the first year and included in the experiment the second year as a second control to help in the comparison of legume residual effects. The design was therefore reduced to a randomized complete block with one factor having 10 treatments the two subsequent years since defoliation treatment was no longer done on maize.

Trial management

The sole maize plots were left fallow (3 months) for part of the season after maize was harvested (about five months after planting), whereas sole legume and maize/legume plots had legumes for the rest of the growing season (6–9 months). Maize (composite) was planted on ridges spaced at 75cm with a population of 53,333 plants ha⁻¹ in 1996 and the two subsequent cropping seasons to study the residual effect of the legumes treatments after two years. *Crotalaria* and *Tephrosia* seeds were obtained from some maize farmers in the WHC who had been using the species for six years, so well adapted to the ecology of the zone. They were uniformly broadcast to the plots and lightly worked into the soil with hand hoe. Legume fallow plots were weeded twice and at the end of the cropping season, fresh biomass of legumes and natural fallow were sampled using two 0.5m lengths of rows for *Crotalaria* and one 1m x 1m quadrant for the others. At the same time, the height of ten legume plants from the four central ridges was measured by holding a level just above the plant and measuring from the ground to the level. At maturity, maize grain yields were estimated from net subplot sizes of 9m² (area of the four central ridges) in 1996 and 18m² in 1997 and 1998. Yields were expressed in Mg grain per hectare at 12% moisture content.

Analytical procedure

Plant height, legume above-ground biomass and maize yield data were compiled onto a computer spreadsheet MSTAT (1985) statistical software. Analyses of variance (ANOVA) were performed for a split-plot in the first year and a randomized complete block design for the second and third years with one factor (cropping systems) in 10 treatments. The interaction between the cropping systems and defoliation was no longer tested the two subsequent years since maize plants were only defoliated the first year.

Results and discussion

Maize canopy management (defoliation)

There was no significant interaction between the cropping systems and defoliation factors for all parameters at both study sites. The mean plant height and fresh

Table 1. Effect of maize defoliation on both legume canopy height and total biomass (fresh weight in Mg ha⁻¹) at Mfonta and Babungo in 1996.

Maize canopy* Management	Mfonta	Babungo
Plant height (cm)		
+ Defoliation	158.8	161.3
– Defoliation	136.2	134.5
LSD (0.05)	6.5	6.8
Biomass (Mg ha ⁻¹)		
+ Defoliation	23.3	26.9
– Defoliation	17.2	18.3
LSD (0.05)	2.1	2.8

*+ Defoliation = removal of lower leaves.

– Defoliation = No removal of lower leaves.

LSD = least significance difference.

biomass yields were comparable for the maize canopy management (Table 1). Defoliating maize at two weeks after silking resulted in an increase of legume plant height by 16% at Mfonta and by 20% at Babungo. Similarly, biomass increased by 12% at Mfonta and by 35% at Babungo. Defoliating maize might have allowed more solar radiation penetration to the lower canopy storey and thus allowed better legume growth. Consequently, the competition for light and water was less for legumes.

Canopy management effects on the average maize yields is shown in Table 2. Maize yields at both study sites were significantly ($p < 0.05$) affected by the defoliation practice relative to the control (–defoliation). Yield reduction was 11% (4.5Mg without defoliation as compared to 4.0Mg ha⁻¹) and 19% for Bambui and Babungo, respectively. This indicates that the removed leaves were still young enough to contribute to carbon assimilation and grain filling. Similar observations were made by McHugh (1985 in a study carried out on maize/groundnut intercropping.

Table 2. Effect of maize canopy management on maize yield (Mg ha⁻¹) at Bambui and Babungo in 1996.

Maize canopy management	Grain Yield (Mg ha ⁻¹)	
	Mfonta	Babungo
+Defoliation	4.0	5.6
–Defoliation	4.5	6.9
LSD (0.05)	0.1	0.6

Table 3. Effect of cropping systems on legume above-ground biomass and grain yields of the companion maize crop at Mfonta and Babungo in 1996.

Cropping* Systems	Mfonta		Babungo	
	Legume biomass ^a (Mg ha ⁻¹)	Maize yield ^b (Mg ha ⁻¹)	Leg. biomass ^a (Mg ha ⁻¹)	Maize yield ^b (Mg ha ⁻¹)
Maize sole	None	5.0	None	6.8
Teph sole	50.4	None	53.2	None
Maize/Teph T ₁	37.5	4.1	44.9	6.1
Maize/Teph T ₂	16.0	4.9	22.7	6.1
Maize/Teph T ₃	8.6	4.8	20.7	6.0
Crot sole	36.5	None	42.7	None
Maize/Crot T ₁	24.2	2.6	36.8	5.4
Maize/Crot T ₂	19.8	3.8	32.7	6.4
Maize/Crot T ₃	6.0	4.9	21.7	6.7
Mean	24.9	5.0	34.4	6.2
LSD (0.05)	2.0	0.9	3.6	NS
CV (%)	22.3	25.4	14.1	13.0

* Teph = Tephrosia; Crot = Crotalaria

T₁ = legume planted at the beginning of the season with maize

T₂ = legume relayed to maize 5 weeks after planting

T₃ = legume relayed to maize at silking

+ NS = not significant

a Only 8 treatments having data were used in the analysis

b Only 7 treatments having data were used in the analysis

LSD = least significant difference.

Crop/legume association effects on legume above-ground biomass and maize yields

Regardless of the location, legumes planted sole significantly ($p < 0.05$) generated more biomass than other treatments (Table 3), with maize/Tephrosia T₃ and maize/Crotalaria T₃ giving the lowest yields (8.6 Mg ha⁻¹ and 6.0 Mg ha⁻¹ at Mfonta, 20.7 Mg ha⁻¹ and 21.7 Mg ha⁻¹ at Babungo, respectively). This could be due to maize shading that might have inhibited the legume growth, and short duration of the fallow (biomass was harvested at the end of the season when the first planting was 9 months, the second 7.5 months and the third 6 months old).

Associating legumes with maize significantly reduced its grain yields at Mfonta compared to the sole maize treatment (5.0 Mg ha⁻¹). The lowest yield was obtained with maize/Crot T₁ (2.6 Mg ha⁻¹). This indicated that maize had been out competed by Crotalaria which is an early maturing species with a faster canopy development (leaf formation and stem extension). At Babungo, intercropping maize with legumes led to a non-significant reduction in maize yield. The most affected treatment was maize/Crot T₁ (5.4 Mg ha⁻¹) due to competition with Crotalaria. In general,

maize/Crot T₃ was 1.5% affected compared to 10% for maize/Tephrosia intercropping over the sole crop. This indicates that Crotalaria was less affected by maize competition than Tephrosia when planted at the same time at Babungo. Whatever the species and cropping patterns, legumes biomass generated was higher in Babungo than Mfonta (Table 3) which showed a significant legume by site interaction as reported in the WHC (Yamoah and Ngueguim, 1992) during a screening work on N₂-fixing legumes. These results also stress the need to respect the agroecological specificity of the species with regard to selection and use for soil improvement. In our study, Babungo offers a better environment for legume production because of its moderate soil acidity and higher base status than Mfonta (Osiname et al., 2000; Yamoah and Ngueguim, 1992).

Residual effects of planted legumes on subsequent maize yields

The data show that over location (Table 4), there was a significant difference between the legume species and

Table 4. Residual effects of legume fallow species and the previous cropping systems on maize grain yield at Mfonta and Babungo, in 1997 and 1998.

Legume fallow species and Cropping system.	Maize yield (Mg ha ⁻¹)			
	Mfonta		Babungo	
	1997	1998	1997	1998
Natural bush	3.1	1.5	4.4	5.0
Maize following maize	2.8	2.0	2.9	4.9
Tephrosia Sole	6.6	2.8	5.6	5.8
Maize/Tephr T ₁	5.1	2.5	3.7	5.2
Maize/Tephr T ₂	3.9	1.9	3.2	4.8
Maize/Tephr T ₃	3.7	2.1	3.3	5.0
Crotalaria Sole	5.3	2.9	7.4	6.9
Maize/Crot T ₁	4.3	2.2	5.0	6.0
Maize/Crot T ₂	3.6	2.1	4.7	5.6
Maize/Crot T ₃	4.4	2.6	3.3	5.0
Mean	4.3	2.3	4.3	5.4
LSD (0.05)	1.7	1.3	1.3	0.9
CV (%)	28.0	21.0	20.0	11.6

cropping systems for maize grain yields in the subsequent year (1997) after the incorporation of biomass at the end of the season in 1996. However, the fallow duration within each legume species didn't influence the residual effects of the latter except at Babungo for *Crotalaria* where it significantly increased maize yields. Relative to the controls (natural bush and maize following maize) there was an increase in maize yields at Mfonta following legume fallows in the order *Tephrosia* > *Crotalaria* and maize/Teph T₁ > maize/Crot T₃ for both legume sole and maize/legume intercropping, respectively. At Babungo, *Crotalaria* sole plots out-yielded both *Tephrosia* sole and natural bush plots while the highest increase in the yield of maize/legume intercropping followed the order maize/Crot T₁ > maize/Tephr T₁ (14% and 74% higher). These above results can be explained that the species and intercropping period effects on maize grain yield are related to the amount of fallow biomass produced, the quality of the fallow biomass, and the ecological conditions in which they were grown. In fact there was a significant correlation ($R^2 = 80\%$ for Mfonta and 68% for Babungo) between the legume biomass produced in 1996 and the maize grain yield generated from its residual effect the following year. Vanlauwe et al. (2001) have found that maize responses to residual effects of some legume species grown in derived savanna (DS) and Northern Savanna Guinea (NSG) were a function of many factors that should be considered before taking a decision to use them. Without carrying out a chem-

ical plant analysis for legume, above plant biomass added to the soil must have contributed equivalents of N chemical fertilizer like urea from maize, *Tephrosia* and *Crotalaria*, respectively. In cash terms this is a very impressive saving for small scale farmers, who have little or no purchasing power for such vital inputs like chemical fertilizers. We can therefore conclude that in monocropping and maize/legume association conditions, *Tephrosia vogelii* should be planted as soil improver at Mfonta, while *Crotalaria juncea* should be planted at Babungo; both legumes are better planted at the onset of the rains.

In 1998, the same plots were cropped to maize in the same conditions to test the duration of the residual effects of legumes (Table 4). There was an overall reduction (average 45%) in maize yield in all treatments at Mfonta, compared to a moderate increase (average 32%) at Babungo. This decrease could be due in part to a decrease in levels of nutrients (mostly nitrogen) generated by legumes and other crop residues at Mfonta which is the poorer of the two study sites as far as soil fertility is concerned (Yamoah and Ngueguim, 1992) and a high rainfall pattern (Kikafunda-Twine, 1990). At Babungo, however, there might have been a build up of nutrients that could have sustained the production in 1998. These results indicate that legume fallows planted at the onset of rain can sustain the soil productivity only for one year where the fertility level is low and two years where it is moderate.

Conclusions

Defoliating maize at both sites significantly ($p < 0.05$) increased both legume plant height and above plant biomass, and partly contributed to a significant grain yield reduction of maize, indicating a reduction in the competition for sunlight and soil nutrients among maize and legume plants. Intercropping maize with legume reduced legume biomass and the associated maize grain yield at Mfonta but not significantly at Babungo. This could be related to the more vigorous growth of maize and the relatively high radiation observed at Babungo, supporting the ecological differences between the two locations. At Mfonta, *Tephrosia* intercropped with maize at planting produced the highest residual effect (5.1 Mg ha^{-1}) of 67% and 84% higher, respectively, as compared with the control treatments (grass bush fallow and maize following maize); while at Babungo the same treatment with *Crotalaria* generated the highest residual effect (5.0 Mg ha^{-1}) of 14% and 74%. These results suggest that the two species have a potential for improving soil productivity when planted at the onset of rains. Residual effects of the two legume species in 1998 produced a grain yield reduction of 45% at Mfonta compared to a moderate increase of 32% at Babungo. This decrease could be due to in part to a decrease in levels of soil nutrients (mostly nitrogen) generated and a high rainfall pattern (favoring water logging) at Mfonta which is the poorer of the two study sites. These results indicate that they can sustain soil fertility only for one year when its level is low and two years if it is moderate.

References

- Conway G. 1997. The doubly green revolution. Food for all in the twenty first Century. Penguin, London, UK.
- Food and Agricultural Organization (FAO). 1985. Changes in shifting cultivation Africa: Seven case studies. FAO Forestry paper 50/1. FAO, Rome, Italy.
- Greenland D.J. 1985. Nitrogen and food production in the tropics: Contributions from fertilizer nitrogen and biological nitrogen fixation. *In*: Kang B.T. and Van der Heid J. (Eds). Nitrogen Management in Farming Systems in Humid and Subhumid Tropics, pp 9–38. Institute for Soil Fertility, Haren, The Netherlands.
- Hof J., Kips P.A., Bisong E.E. and Trinh S. 1987. Sols, land use and land evaluation of the North West Province, Cameroon. Vol. IIIa FAO/UNDP Soil Resources Project. Technical Report No. 39. IRA Nkolbison, Yaounde, Cameroon.
- Kikafunda-Twine J. 1990. Highland Maize Agronomy. Annual Report, Inst. de la Recherche Agron. (IRA), Bambui Station, Cameroon.
- McHugh D. 1985. Effect of fertilizer on maize/groundnut intercropping. Annual Report. IRA, Bambui Station, Cameroon.
- McHugh D. and Kikafunda-Twine J. 1995. Ten years of farming systems research in the North West Highlands of Cameroon. Resource and Crop Management Research Monograph No.13. International Institute of Tropical Agriculture (IITA), Ibadan, Nigeria.
- MSTAT. 1985. A Microcomputer Statistical Program for the Design, Management and Analysis of Agronomic Research Experiments. Michigan State University, USA.
- Osiname O.A., Meppe F. and Yamoah C. 1992. Soil fertility constraints to maize grain yield in the Western Highlands of Cameroon. Amer. Society of Agronomy Meeting, Minneapolis, Minnesota, USA.
- Osiname O.A., Meppe F. and Everett L. 2000. Response of maize (*Zea mays*) to phosphorus application on basaltic soils in North-western Cameroon. *Nutrient Cycling in Agroecosystems* 56:209–217
- Sanchez P.O. and Hailu M. (Eds). 1996. Alternatives to slash and burn agriculture. *Agriculture, Ecosystems and Environment* (Special issue). 58(1).
- Vanlauwe B., Wendt J. and Diels J. 2001. Combined application of organic matter and fertilizer. *In*: Tian G., Ishada F and J.D.H (Eds), *Sustaining Soil Fertility in West Africa*. SSSA Spec. Publ. No. 58, SSSA, Madison, WI, USA., pp. 247–279.
- Van Ranst E., Pauwels J.M., Debaveye J. and Zweier K. 1989. Soil Characterization and maize fertilization of PAFSAT experimental farms in the southern part of the North-West Province of Cameroon. Technical Report No.1 Soil Science Dept., Dschang Univ. Centre, Cameroon.
- Van Ranst E., Pauwels J.M., Debaveye J. and Zweier K. 1990. Soil Characterization and maize fertilization of PAFSAT experimental farms in the Northern part of the North West Province of Cameroon. Technical Report No.2. Soil Science Dept., Dschang Univ. Centre, Cameroon.
- Weber G. 1996. Legume-based technologies for African Savannas: Challenges for research and development. *Biological Agriculture and Horticulture* 18: 309–333
- Yamoah C.M. and Ngueguim M. 1992. Soil fertility conservation for sustainable crop production: Experiences from some highlands areas of North-West Cameroon. IRA/NCRE Annual Report, Bambui Station, Cameroon.

Integrated Soil Fertility Management: Use of NUTMON to Quantify Nutrient Flows in Farming Systems in Central Kenya

Kathuku A.N.^{1*}, S.K. Kimani², J.R. Okalebo¹, C.O. Othieno¹, and B. Vanlauwe³

¹ Moi University, Soil Science Department Box 1125, Eldoret, Kenya; * Corresponding author: Tel: +254 721 227 347, E-mail: angelandan2000@yahoo.com; ² Kenya Agricultural Research Institute, National Agricultural Research centre, Muguga, P.O. Box 30148, Nairobi, Kenya; ³ Tropical Soil Biology and Fertility Institute (TSBF)-CIAT, P.O. Box 30677, Nairobi, Kenya

Abstract

A study based on Participatory Learning and Action Research (PLAR) to categorize soil fertility management was carried out in three districts of Central Kenya: Kirinyaga, Maragua and Kiambu. The PLAR classified farms according to their economic and soil fertility management status. In each district 20–30 farmers were selected who represented three hundred farmers. The selected farmers had discussions with the facilitators who grouped them into three categories according to their soil fertility management level: Good (Class I), Average (Class II) and poor (Class III). Three farmers in Classes I and II and four in Class III were selected to represent the groups. Out of the selected representatives in each group, two were selected for Nutrient Monitoring (NUTMON) questionnaire assessment and this was done during the short rains cropping season. The farmers were visited at their homes and researchers had free discussions with them related to their farming systems and soil fertility management. Farm plans were drawn, fertilizer and manure inputs recorded and cash in and out flows monitored. Results were analyzed using NUTMON software model. Results showed a general trend of negative nutrient balances particularly in food crop fields. Mineral nutrient inputs (IN1) was high in classes II and I but low in class III, low negative nutrient balances were recorded in Kiambu district while Maragua district had higher nutrient balances. In fields where both organic and inorganic nutrient sources were used had positive nutrient balances.

Key words: Nutrient balance, nutrient monitoring, mineral fertilizer input, organic fertilizers input, soil fertility management, sustainability indicator

Introduction

Soil fertility replenishment in Sub-Saharan Africa (SSA) is critical to the process of poverty alleviation (Place *et al.*, 2003). African poverty is mainly a rural phenomenon attributed to low soil productivity, while per capita arable land in SSA has shrunk from 0.53 to 0.35 hectares between 1970 and 2000 (FAOSTAT, 2002). Therefore, accelerated and sustainable agricultural intensification is required. Yet intensification, increased agricultural productivity and

improved rural livelihoods cannot occur without investment in soil fertility (Place *et al.*, 2003). Limited use of nutrient inputs among smallholder farmers exerts pressure on soil nutrient deficiency. The estimated nutrient losses due to erosion, leaching and crop harvests are sometimes staggering, at over 60–100kg of N, P, and K per hectare each year in Western and Eastern Africa (Stoorvogel and Smaling, 1990; De Jager *et al.*, 1998).

Over the past 10 years in Sub-Saharan Africa, much attention has been given to the quantification and

estimation of nutrients that enter and leave agricultural systems (Lesschen *et al.*, 2003). The balance between these nutrient inputs and outputs shows whether the agricultural system is a net gainer or a net loser of soil fertility. In many areas of Kenya, low soil fertility tends decline further, as farmers remove many nutrient outputs in crops, crop residues and through losses by processes such as leaching, and soil erosion. Nutrient mining have led to negative nutrient balances. In Embu district, Central Kenya, nutrient balances of N, P, and K were -55 , 9 and -15 $\text{kg ha}^{-1} \text{yr}^{-1}$ respectively in 1998. In 2003, in the same district, nutrient balances further decreased to -116.2 , -22.1 and -31.7 $\text{kg ha}^{-1} \text{yr}^{-1}$, N, P and K respectively (Van den Bosch *et al.*, 1998; Lesschen *et al.*, 2003). The amounts of negative nutrient balances are not matched by inputs in little fertilizers and manure applied and/or biological fixation in smallholder farming systems.

Recent studies have indicated that, use of well-managed nutrient replenishment regimes incorporating use of manure and modest amounts of fertilizers are important to increased and sustained crop yields (Kimani *et al.*, 1998). Among several study approaches carried out, which indicated good results, was integrated soil fertility management (ISFM). As a result ISFM is becoming more accepted by development and extension programs in SSA, and, most importantly by smallholder farmers. ISFM is about expanding the choice set of farmers by increasing their awareness of the variety of options available and how they may complement or substitute for one another. Integrated soil fertility management encompasses a range of driving factors and consequences such as biological, physical, chemical, economic and political aspects of soil fertility degradation (Place *et al.*, 2003). ISFM provides a wide choice use of both organic and mineral fertilizer inputs to smallholder farmers, but many farmers are still staggering on how much of organic and mineral fertilizers to apply.

Monitoring nutrient flows and economic performance (NUTMON)

Farm-NUTMON is a research tool that integrates the assessment of stocks and flows of the macronutrients such as nitrogen, phosphorus and potassium on one hand and economic farm analysis on the other. Farm-NUTMON allows (i) the estimation of the extent to which farmers generate income from soil nutrient mining, (ii) assessment of the impact of changes in farm

management techniques on nutrient balance and economic performance at activity level and farm level, and (iii) calculation of the economic impact of exogenous changes on the farm and activity level (Van den Bosch *et al.*, 1998). Thus NUTMON assesses the amounts of both organic and mineral fertilizer inputs a farmer uses and nutrient losses through crop harvests, removal of crop residues, leaching, gaseous losses and erosion.

NUTMON concept for nutrient monitoring has five in and outflows: IN1: mineral fertilizer, IN2: manure, IN3: atmospheric deposition, IN4: biological nitrogen fixation and IN5: sedimentation. Outflows: OUT1: harvested products, OUT2: removal of crop residues, OUT3: leaching, OUT4: gaseous losses and OUT5: erosion (Smaling and Fresco, 1993; Smaling *et al.*, 1996). NUTMON provides a quick tool for monitoring the sustainability of ISFM methods used.

The broad objective of this study was to monitor nutrient inflows, outflows and balances in central Kenya using NUTMON model. The specific objectives of the study were: (1) to assess nutrient balances at sub-system level to shed light on the relative contributions of individual farm activities, both crop and livestock, to the farm's nutrient balance, (2) to capture soil fertility patches within the farm to narrow the gap of broad fertilizer recommendation, and, (3) to assess nutrient balances at farm level to improve understanding of the degree of nutrient mining of different farming systems in central Kenya

Study approach and concepts

A team of scientists from KARI, MUGUGA south and Ministry of Agriculture carried out a soil fertility survey using a diagnostic phase of Participatory Learning and Action Research (PLAR) in three districts of Central Kenya: Kirinyaga, Maragua and Kiambu. The major objective of the survey was to make it easy for development initiatives in the districts, particularly on soil fertility management. With the help of the farmers who convened for the survey meeting that classified the farms into two major categories (i) according to their Wealth (Physical) and (ii) according to their fertility management (according to crop performance). In each farm soils were sampled for laboratory analysis. The team scored class I for good, Class II for medium and Class III for poor according to their soil fertility management. Out of the farmers who attended 10 farmers were selected: 3 in Class I, 3 in Class II and 4 in Class III to represent the group. From the representatives two

farms were selected in each class for nutrient monitoring assessment (NUTMON). The farmers were visited in their farms, their farm plan (crops (Primary Production Unit, PPU)), topography and soil types (Farm Section Unit, FSU), Kraals, manure or compost heaps, Latrine (Redistribution Unit, RU), animal (Secondary Production Unit, SPU) and their confinement areas were sketched. The farmers were interviewed using NUTMON questionnaire, which captures the inputs and outputs in each PPU within the farm and any soil erosion control measures undertaken in the farm. The data collected using the NUTMON questionnaire and laboratory soil analysis results was entered in NUTMON data entry model and analyzed using the NUTMON data processing model. Results were subjected to Ms Excel for Windows for pivot table reports and nutrient balance graphs.

Results and discussions

The results showed that Class I farmers in Kirinyaga had both positive nutrient balances and net farm cash flow. In Maragua and Kiambu, negative nutrient balances were observed, with Nitrogen (N) and Potassium (K) being the most limiting as low as -65.9 and -45.5 kg ha^{-1} during the short rains respectively, but the net farm cash flow was positive. Class II farmers in all the districts had similar trends with rampant negative nutrient balances and low net farm cash flow.

The economic and soil fertility management levels of the farmers in the three districts was clearly shown by Class III farmers who represents 88%, 62% and 56% of the three hundred farmers in Kirinyaga, Kiambu and Maragua districts respectively. Farms in this Class showed that, majority of them had large negative nutrient balance with N and K being severe and to some extent deficiencies of phosphorus (P) were observed. The balances were at the tune of -85.3 to -108.2 kg ha^{-1} and -36.0 to -54.9 kg ha^{-1} for N and K during the short rains respectively. The lowest observed P deficiency was -17.4 Kg ha^{-1} in the short rains in Class III at Maragua. The net farm cash flow showed negatives, recorded Kshs. $-2,660$ in Maragua, an indication of a loss of income invested in the farming system but two thirds showed positive cash flows though less than a dollar per day.

It is quite clear from the results that in all the farms integrated soil fertility management was practiced, but, with limitations in each household set up, depending on financial capacity, innovations and prospects of the household head. This is because in each farm there were both organic and inorganic sources of nutrient inputs. Much of these initiatives are due to farmer innovations and adaptations, often in response to macroeconomic and sectoral reforms that have driven up real fertilizer prices throughout the continent. Figure 1 shows that input of mineral fertilizers is high (IN1), for class I farms and low organic inputs (IN2). Due to high input of mineral fertilizers, much of nitrogen is lost

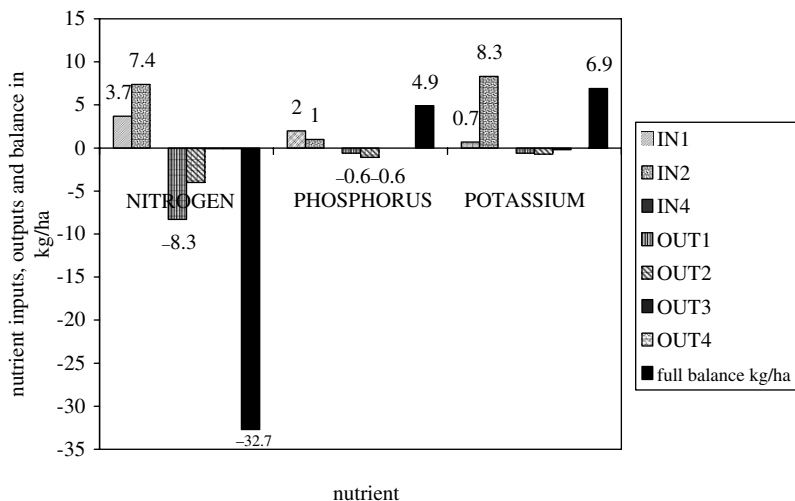

Figure 1. Inputs, outputs and balances of nutrients in a soil fertility management of class I farm.

through leaching and gaseous loss. The other macronutrients (P and K) are commonly lost through crop harvest and removal of crop residues, OUT1 and OUT2 respectively, particularly potassium (K) is more vulnerable in those farm section units with coffee and maize. This imbalance of fertilizer inputs and outputs leaves the farm with negative nutrient balances. A similar imbalance of nutrient inflows and outflows was observed in Kisii, Kakamega and Embu districts of Kenya where mean N, P and K balances were $-71 \text{ kg ha}^{-1} \text{ yr}^{-1}$, $-9 \text{ kg ha}^{-1} \text{ yr}^{-1}$ and $+3 \text{ kg ha}^{-1} \text{ yr}^{-1}$ respectively (De Jager *et al.*, 1998). Class II farms (Figure 2) seem to strike a balance of both mineral and organic

sources of nutrient inputs, though the general rate of input application in both organic and mineral inputs are quite low. The inputs range from $3\text{--}7.4 \text{ kg ha}^{-1} \text{ N}$, $1\text{--}2 \text{ kg ha}^{-1} \text{ P}$ and $0.7\text{--}8.3 \text{ kg ha}^{-1} \text{ K}$. There is minimal loss of nutrients through gaseous (volatilization) and leaching due to higher application of organic sources of nutrients.

Much investment on organic fertilizer inputs has been practiced in Class III farms (Figure 3), no loss through leaching and gaseous loss but soil erosion (OUT5) threatens their sustainability, though minimal. Nutrient mining through crop harvest and crop residue removal is evident. Generally, K input is low in terms of

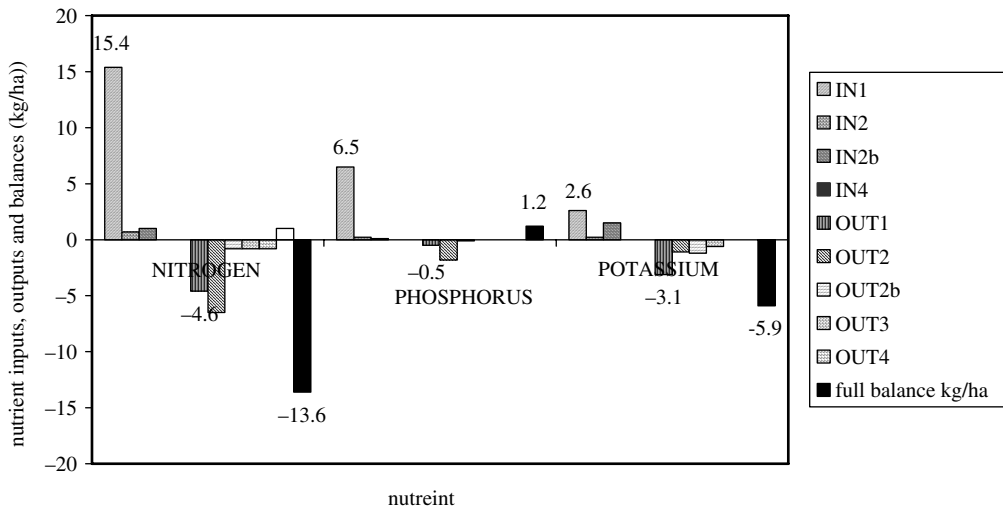

Figure 2. Inputs, outputs and balances of nutrients in a soil fertility management of class II farm.

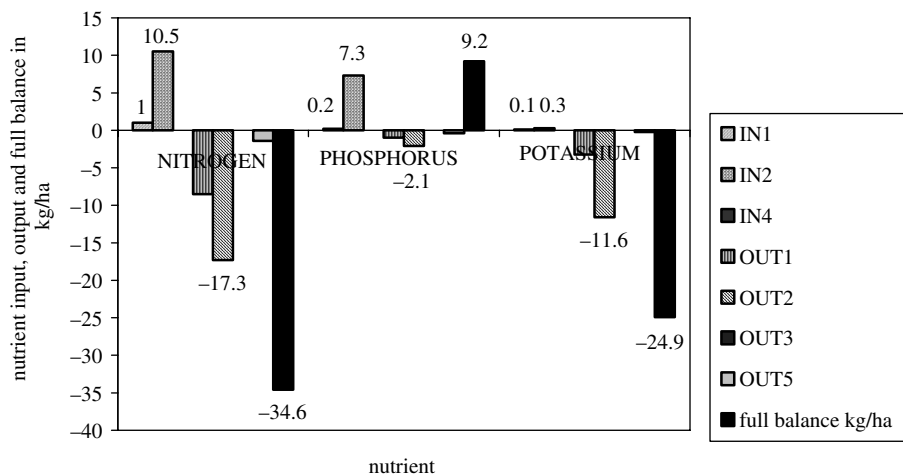

Figure 3. Inputs, outputs and balances of nutrients in a soil fertility management of class III farm.

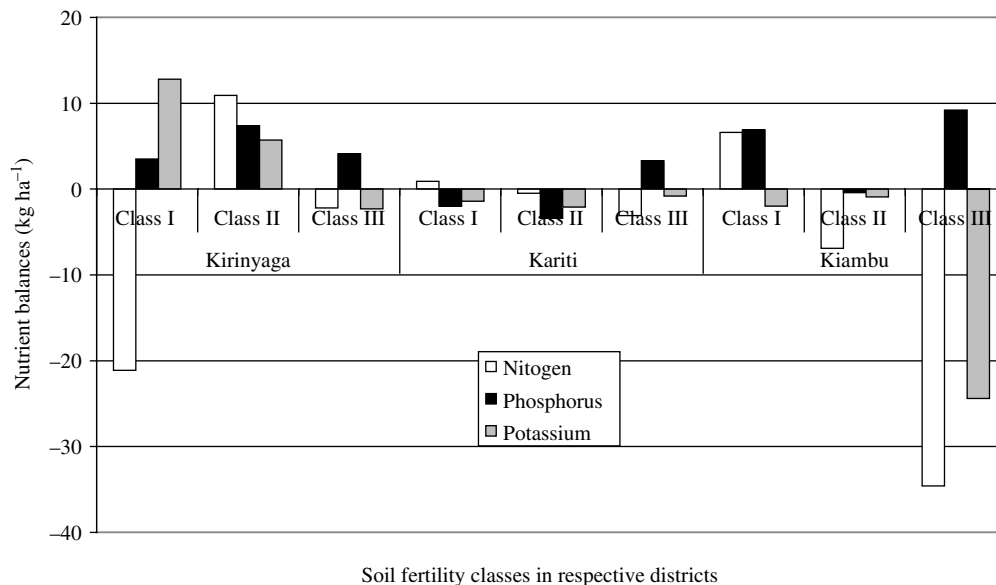

Figure 4. Nutrient balances in relation to fertility class in three districts in central Kenya.

mineral fertilizer input as the widely used fertilizers are diammonium phosphate (DAP) and Calcium ammonium nitrate (CAN). Much of K is removed through crop harvest hence resulting negative K balances. From Figure 4 the summary of all the classes, nitrogen (N) and K are the most limiting nutrients. This is a common in Sub-Saharan Africa (Stoorvogel and Smaling, 1990). From the analysis, results show that all the FSU occupied by root crops: arrow roots sweet potatoes and Irish-potatoes showed higher mining of soil nutrients this is particularly because these crops are heavy feeders. These crops were able to mine nutrients through crop harvest and crop residual removal up to 105, 16.6 and 48.8 kg ha⁻¹ N, P, K per season respectively. According to De Jager *et al.*, 1998, farmers in

Kisii, Kakamega and Embu districts earn an average of US\$ 2.8 per day. Similarly in Table 1 shows that the agro-economic performance of class I farms is stable even without off-farm income but class II farms depend mostly on off-farm income whereas class III farmers entirely depend on farm income, this gives an average of US\$ 1–5 per day, the lowest being recorded in class III. This could be the reason why class II farms use substantial amounts of fertilizers than class III farmers who rely mainly on organic fertilizer and little inorganic fertilizer inputs.

Conclusions and recommendations

ISFM practices were thriving in these agroecosystems, as all farms were characterized by use of both organic and inorganic nutrient sources for soil fertility replenishment strategies but there is still need to develop more attractive options, components and integrated options for smallholder farmers. Farms in which relatively high amounts of organic inputs were being used showed positive nutrient balances while use of singly inorganic fertilizers was accompanied by leaching and gaseous nutrient losses as calculated by NUTMON background database in relation to rainfall precipitation per season. Uniform application of both organic and inorganic nutrient sources accompanied

Table 1. Farm cash flows.

Cash Flows	Amount (KShs.)		
	Class I	Class II	Class III
Net Cash Flow SPU	68476	1494	8455
Net Cash Flow RU	-17600	6260	1930
Off-Farm income	0	33000	0
Farm Net Cash Flow	50876	7754	10385
Household Net Cash Flow	50876	40754	10385

Key: PPU- primary production unit (crops), SPU-Secondary production unit (animals), RU-Redistribution unit (boma, manure heap, Kraals, Compost heap, Latrine, etc.).

by crop rotation is more likely to alleviate fertility gradients in the farm caused by planting heavy feeders in one portion of the farm for long or application of inorganic fertilizers to commercial crops only and organic to food crops. Much remains to be done in increasing ISFM practices in smallholder farmers owing to the fact that in many farms negative nutrient balances tends to dominate.

Acknowledgement

Appreciation goes to Ministry of Agriculture field staff (extension officers in Kerugoya and Kariti), farmers in the research site for their cooperation, and KARI, Muguga Chemistry Laboratory technicians. My sincere gratitude goes to Dr S.K. Kimani of KARI, Muguga for his critical scrutiny of this paper, dedicated and collaborative assistance throughout the research period, Job Kihara of TSBF-CIAT, Nairobi for dedicating his time to teach me NUTMON and Rockefeller Foundation for financial support.

References

De Jager A., Kariuku I., Matiri M., Odeno M. and Wanyama J.M. 1998. Monitoring nutrient flows and economic performance

in African farming systems (NUTMON). IV. Linking nutrient balances and economic performance in three districts in Kenya. *Agriculture ecosystems and environment* 71 (1–3): 81–92.

FAOSTAT 2002. Food and agricultural Statistical Data base. www.foa.org/waicent/portal/statistics-en.asp.

Kimani S.K., Mangale N., Gichuru M., Palm C., Njuho P. and Wamuongo J. 1998. Integrated Use and effects of Manure with Modest Application of Inorganic fertilizers on soil Properties and Maize production in the Central Kenya Highlands. Report no. 2 to Rockefeller Foundation, December 1998.

Lesschen, Asiamah, Gicheru, Kanté, Stoovorgel, Smaling, 2003. Scaling Nutrient balances. Draft report, February 2003.

Place F., Christopher B.B., Ade Freeman H., Ramisch J.J. and Vanlauwe B. 2003. Prospects for integrated soil fertility management using organic and inorganic inputs: evidence from smallholder African agricultural systems. *Food Policy* 28: 365–378.

Smaling E.M.A. and Fresco L.O. 1993. A decision-support model for monitoring nutrient balances under agricultural land use (NUTMON). *Geoderma* 60: 237–256.

Smaling E.M.A., Fresco L.O. and De Jager A. 1996. Classifying, monitoring and improving soil nutrient stocks and flows in African agriculture. *Ambio* 25: 492–496

Stoovorgel J. and Smaling E. 1990. Assessment of nutrient depletion in sub-Saharan Africa: 1983–2000. Report no. 28, Vol.1–4 Winand Staring Centre, Wageningen, Netherlands.

Van den Bosch H., Gitari J.N., Ogaro V.N., Maobe S. and Vlaming J. 1998. Monitoring nutrient flows and economic performance in African farming systems (NUTMON). III. Monitoring nutrient flows and balances in three districts in Kenya. *Agriculture ecosystems and environment* 71 (1–3): 63–80.

Optimizing Soil Fertility Gradients in the Enset (*Ensete ventricosum*) Systems of the Ethiopian Highlands: Trade-offs and Local Innovations

Tilahun Amede^{1*} and Endale Taboge²

¹ International Livestock Research Institute/International Water Management Institute (ILRI/IWMI), Addis Ababa, Ethiopia, P.O. Box 5689, Addis Ababa, Ethiopia, Tel. + 251-116-463215, 911-230135; Fax. + 251-116-461252;

* Email of correspondence author: T.Amede@CGIAR.ORG; ² Areka Research Centre, Southern Regions Agricultural Research Institute. P.O. Box 79, Soddo, Wollayita, Ethiopia

Abstract

Ensete ventricosum is a perennial, security crop that feeds about 13 million people in Ethiopia. It is grown in the homesteads, covering about 18% of the farm, in mixture with Coffee, kale, and other vegetables. The recent shift from enset to cereals and continual soil fertility decline in the outfields caused food deficit for at least three months in a year. The objective of this work was to evaluate the effect of soil fertility gradients on enset growth, identify the major growth limiting nutrients, and identify farmers' decision making criteria in allocating resources to various enterprises. The research was conducted on farmer's fields of resource rich (G1) and poor (G3) for four years (2001–2004). Enset transplants were planted in homestead and outfields. Application of fertilizers by farmers to different units over seasons and years was recorded. Enset growth and nutrient content was measured. The results showed that the G1 group produced about 2xs more organic waste than G3, and purchased chemical fertilizers 5xs more than the G3 farmers. About 80% of the organic resource produced was allocated for maintaining soil fertility, while 20% being allocated as cooking fuel. Of this 65% is allocated for the enset field in the homestead. There were significantly higher N, P, K and Ca contents in the homestead soils than in the outfield, regardless of farmers' resource endowment. The P content of the outfield was the lowest, less than 25% of the P content of the homestead. Similarly organic matter in the outfield was only about 40% of the homestead. Enset plants grown in the outfields experienced about 90% height reduction and 50% reduction in pseudo stem diameter, regardless of resource categories, while the NPK content of the plant tissues grown in the outfield was significantly higher, in some case up to 150% than those planted in homestead. We thus concluded that growth reduction in the outfield was not directly related to NPK deficiency, but it could have been caused by off-season moisture stress in the outfields, manifested by low soil organic matter. The attempt to attract resources to the outfield using enset as an attractant crop failed, not because of labour shortage but because of unavailability of enough organic resources in the system. Hence on spot management of nutrients was initiated by farmers.

Key words: *Ensete ventricosum*, farmer innovation, growth, nutrients, soil fertility gradient

Introduction

Enset system is one of the four major agricultural systems in Ethiopia feeding about 13 million people, more than 20% of the population residing in the southern Ethiopian highlands. Enset (*Ensete ventricosum*) is a

perennial, banana-like crop, endemic to Ethiopia that produces pseudo stem and a starchy belly corm pulped for food, feed and fibre. Although the exact age of Enset domestication is not yet established, it was practiced in Ethiopian highlands between 5000 and 10000 years ago (Brandt et al., 1997). It has probably given rise

to better intensification of production systems involving year round cultivation of the land, with emphasis on root crops and close integration between livestock and crop production units (Brandt et al., 1997; Kippe, 2002). One plant of 5 years old could produce up to 21 kg of local food (*Kocho*, *Bulla* and *Amcho*) and 3.6 t/ha dry matter residue (Kippe, 2002). It is commonly grown in the homesteads, in mixture with Coffee, kale, sweet potato seedlings and other high value vegetables, covering about 18% of the farm. Other fillers of the system are maize, wheat, potato and beans, grown mainly in the mid fields and outfields either sole or intercropped. Enset in the sub-system fulfils both production and protective functions (Kippe, 2002). Because of its very high yield it covers the food demand of household covering from 25% where it is a subsidiary crop to 85% where it is the major food crop (Tsgaye, 2002). Its funnel like leaves and spongy root systems form mate-like structure in the root zone that minimizes soil erosion and run-off, which ultimately improves the water and nutrient budget of the sub unit. However, like that of the banana systems in Uganda (Bekunda, 1999), it also attracts most of the organic waste whereby farmers allocate about 80% of the organic manure and crop residue to the enset field, including the nutrients coming from outfield in terms of feed and mulch. As a consequence, the outfields and midfields suffer from very low soil fertility status, aggravated by farmers' preferential management, soil erosion and nutrient mining (Amede and Kirkby, 2004). Whole farm nutrient flow analysis by farmers, and yield variability across the farm units in the area indicated that there was a positive N and P balance, while the outfields indicated largely negative N and P balances for all farmers of various social categories (Elias, 2000). The same trend was observed for banana system in Uganda, with the highest deficient being in the outfield of resource-poor farmers (Bekunda, 1999) as their financial capacity to buy chemical fertilizers is very weak (Elias, 2000).

In recent years, the Enset system has been in jeopardy in southern Ethiopia partly due to the desire of town dwellers to shift to the 'prestige' foods of cereals thereby affecting the market opportunities to Enset products and partly due to decreased number of animals to produce enough manure to support the enset fields. As a consequence of the shift accompanied by increasing human population, the system has been experiencing food deficit for at least 3 months in a year in recent years (Amede et al., 2004). Decreasing farm size, currently 0.32 ha per family of 7, and declining productivity of the system to support household needs

also aggravated food deficit. Decline in productivity was primarily associated with decline in soil fertility and increased incidence of Enset pests (Amede et al., 2001). Farmers tend to build hot-spots of fertility knowingly or unknowingly, based on their own priorities of crops, labour and financial investments. The Enset sub-unit became a hotspot to application of organic residues due to social favouritism towards Enset as a security crop for bad years (Brandt et al., 1997; Tsgaye, 2002). Some argue that farmers apply organic waste mainly in the home gardens is due to distance effects to the house, demanding less labour needed to transport household refusal, stall manure and enset by-products (Bekunda, 1999; Elias, 2000).

Although Enset is a high yielding crop whereby only 42 mature plants per year, grown in a small plot of land (Kippe, 2002) could support the food demand of a household of seven, the system became vulnerable to frequent food crisis in the last ten years, and the population became food aid dependent for at least 3 months per year. Hence there is an immediate need to expand the Enset field, which is currently less than 20% in average to about 45% to become food self sufficient with the existing yield and production inputs (Amede et al., 2004). Alternatively, there is a need to double the yield of the cereal crops per area to feed the growing population, which may in turn demand an extensive use of inputs and innovations. On the other hand, expansion of enset from the traditional fertile home gardens to the non-fertile outfields will call for an improved soil fertility management strategy that may require more organic inputs and sustainable nutrient flows. Elias (2000) noted the interest of farmers in the region to continually expand the Enset field to the outfield as farm land holding decreases.

We hypothesise that since Enset is a security crop of the system that people rely on in bad days, growing it in the outfield as an attractant would be an incentive for farmers to transport more manure and organic resources to the outfields.

The objectives of this work were (1) to evaluate the effect of soil fertility gradient on growth and productivity of Enset, (2) to quantify the amount of organic matter that farmers would bring to the outfield following Enset as an attractant crop, (3) to identify the major growth limiting nutrients for possible expansion of Enset to the outfield, and, (4) to learn about farmers' decision making criteria in allocating nutrients and organic resources to various farm plots and/or enterprises.

Materials and methods

Characteristics of the study area

The research was conducted in southern Ethiopian highlands, Gununo, Areka. Gununo is situated at 37° 39' E and 6° 51' N about 430 km south-west of Addis Ababa, at an altitude range between 1880 and 1960 m.a.s.l. Topography is characterised by steep, undulating slopes divided by v-shaped valleys of seasonally intermittent streams. Mean annual rainfall and temperature are about 1300 mm and 19.5°C, respectively, with bimodal rainfall. The short rainy season (*belg*) extends from March to June while the main rainy season (*meher*) extends from July to the end of October. The months of July and August receive the highest rainfall amounts that cause significant soil erosion, mainly in the outfields. Eutric Nitosols are the dominant soils, slightly acidic in nature, and are characterised by phosphorus fixation.

The farming system is subsistence, mixed crop and livestock production, with relatively fewer livestock than elsewhere in Ethiopian highlands. Currently less than 15% of households own oxen. Gununo is characterised by very high population density (about 450 people km²) with only about 0.32 ha for a family of seven, so small that some children are not in a position to inherit land. Hence, the majority of young people migrate to other parts of the country as labourers. Share cropping and renting of land are also common, especially among young farmers who do not own land. For the same reason, hillsides that were formerly used as grazing areas or tree plots came under cultivation.

Experimental methods

Farmers have identified soil fertility decline as one of the six major system constraints (Amede et al., 2001), apparent particularly in the distance fields. Two groups of farms, belonging to resource-poor and -rich farmers with clear soil fertility gradients were selected through participatory negotiation. Those willing farmers planted Enset transplants in May 20, 2001 in both homestead (5 m away from the house) and outfields (about 60 m away from the house). Farmers opened pits, watered the holes and planted the transplants. Sixteen plants were planted per treatment with spacing of 2 m², in four replications following the contour. Researchers have trained farmers on how to record the amount of organic matter (household

refusal, stall manure, mulch, crop by-products) and mineral fertilizers (Urea or DAP) they may apply to the different fields of the farm in general and to the Enset planted in the homestead and outfields in particular. The researchers measured plant height and pseudo stem diameter as growth parameters. We also recorded farmer's perceptions on alternative soil fertility management options and on their decision making criteria to allocate organic/inorganic fertilizers to various fields and enterprises through structured questioners (using pair wise ranking) and various PRA tools (resource flow analysis, resource mapping, key informant and informal discussion).

On February 20, 2004, shortly before the beginning of the short rainy season, soil samples were collected from the Enset inter rows of the above 20 cm of the homestead and the outfield, from the four replications. Additional soil samples were collected from the neighboring outfields. Similarly, four upper leaves per plant per replication were harvested for nutrient analysis. Plant and soil samples were oven dried to constant weight, then ground to pass through a 1.0 mm sieve and analyzed for total NPK by Kjeldahl digestion with concentrated sulfuric acid (Anderson and Ingram, 1993). Nitrogen and phosphorus were determined colorimetrically (Parkinson and Allan, 1975) and potassium using atomic absorption spectrophotometer. Similarly, the soil samples were analyzed for N, P, K and Ca using methods given by Anderson and Ingram (1993). Organic C was determined using Wakley-Black method.

Treatment differences were tested using ANOVA and treatment means were compared by LSD at P<0.05 (Jandel Scientific software).

Results

Organic Resources Production and Distribution

The amount of organic resource on farm depended upon the resource endowment category of farmers (Tables 1 and 2) in that resource-rich farmers (G1) produced more organic residue than resource-poor farmers (G3) because of owning more animals and more land to produce higher amount of crop residue and forages. The G1 group produced about 2x more farm yard manure and crop residue than G3. Similarly, the G1 farmers were in a position to purchase inorganic fertilizer, Di Ammonium Phosphate (DAP), about five times more than the resource poor farmers (Table 2).

Table 1. Organic resource production by resource-rich (G1) or resource-poor (G3) farmers and its distribution to different farm sub-units in Areka, Southern Ethiopia, 2002.

Farmers' category	No. of Animals		Organic manure (Kg/week)		Use in %		Distribution in the field %			
	Cattle	Sheep	FYM (Wet)	Others	Soil Fert.	Fire wood	Home stead	Mid field	Mid field	Outfield
G1										
A	4	2	101.5	15.0	75	25	70	30	0	Inorganic
B	3	0	72.5	12.3	90	10	50	30	20	Inorganic
C	4	1	116.0	11.5	80	20	70	20	10	Inorganic
Mean	3.67	1.00	96.67	12.93	81.67	18.33	63.33	26.67	10.0	
SE	0.33	0.58	12.80	1.06	4.41	4.41	6.67	3.34	5.78	
G3										
A	2.00	0.00	72.50	8.00	70.00	30.00	40.00	30.00	30.0	–
B	0.00	2.00	29.00	7.50	100.00	0.00	85.00	15.00	0.00	–
C	2.00	0.00	58.00	6.20	60.00	40.00	65.00	25.00	10.0	–
Mean	1.33	0.67	53.17	7.23	76.67	23.33	63.33	23.33	13.3	
SE	0.67		12.80	0.54	12.03	12.03	13.03	4.41	8.83	

Table 2. Major crops grown in different positions of the farm and crop residues and chemical fertilizers applied to the respective crops by resource-rich (G1) and resource-poor (G3) farmers in 2002/2003 growing season in Areka.

Crop grown	Position in the farm	Type of fertilizer applied	Amount of fertilizer applied (kg) (DAP)/ 500 m ²	
			FarmersG-1	FarmersG-3
Enset-Coffee mixture	Home stead	Organic	80 bundles*	12 bundles*
Sweet potato	Mid field	organic	none	none
Maize	Mid/Out field	Inorganic	29 kg DAP	9 kg DAP
Wheat	Mid/out field	Inorganic	7 »	3 »
Teff	Mid/out field	Inorganic	29 »	3 »
Potato	Out field	Inorganic	7 »	none

The organic source is a mix of crop residues from maize stover, wheat stover, Enset residue and other mixtures. *One bundle ≈ 6.5 kg dry matter.

However, the proportional distribution of resources among various farm sub units was similar across wealth categories. In general, the multi-storey production system with coffee-Enset field around the home garden is favoured to receive high amount of organic matter. Resource flow record of the respected farms showed that about 80% of the organic resources that farmers are producing are allocated for maintaining soil fertility, the rest 20% being allocated as cooking fuel (Table 1). Of the organic resources allocated for soil fertility maintenance about 65% is allocated for the homestead, where the most important security crops, like Enset and Coffee are grown and the remaining amount being allocated for the nearby midfields. Crops grown in the outfields did not receive any organic manure in farms of both resource endowment categories. However, resource rich farmers applied DAP to the outfield maize and potato crops.

When farmers were asked to identify the major five reasons behind to apply most of the organic waste in the homestead year after year, they have identified the following, namely (1) there is no enough organic matter to apply in good amount all over the farm (100%), (2) the most important crops in the homestead field (100%), (3) Enset is traditionally grown in the homestead and the organic matter follows it (100%), (4) there is lack of labour to carry the organic matter in the outfield (33%), and, (5) soil erosion will remove the organic matter if applied in the outfield (33%). Besides, there was a social consensus that the most important security crops (e.g. Coffee, Enset and Taro) be planted around homesteads to protect them from theft, wild animals and manage them better, hence a better care to nearby fields. In some cases, like farmers G1, the heads of the households were willing to transport the organic manure while who are doing the actual work, women

and children, were sceptical to implement it due to the traditional favouritism to the homestead fields.

Soil fertility gradients

The differential application of different sources of fertilizers within the farm over years created a clear soil fertility gradient from the home stead to the outfield soil nutrient status decreasing from the homestead to the outfields, regardless of resource endowment categories. In this study, there was a significant difference in nitrogen, phosphorus, potassium and calcium contents of the soil between the homesteads and the outfields, regardless of farmers' resource endowment categories (Figures 1, 2 and 3). However the N concentration of the outfield was adequate, but P was the major nutrient in deficit in the outfield followed by potassium. In contrary to the expectations, the N, K and Ca concentration of the resource poor farmer was as good, and in some cases better than the fields of the resource-rich farmer. Phosphorus content was significantly higher in the homestead units of G1 than G3, though P content of the outfield was less than 25% of the P content of the homestead in both categories. Similarly, there was significant decrease in organic matter with distance from the home whereby the organic matter concentration in the outfield was about 40% of the homestead

field regardless of farm categories. Despite differences in organic matter application and nutrient status there was no major change in soil pH between farms neither of the two wealth groups nor within farms (Figure 3). However, in G1 the pH in the outfields was reduced from 6.65 in the homesteads to 5.95 in the outfields.

Enset nutrient contents

Nutrient content in the leaves and young stems of the Enset plant showed a completely reversed trend to the soil nutrient concentration in that enset plants grown in the outfield contained a higher concentration of major nutrients, NPK (Figure 4), and in some case, like K the concentration was 150% or higher in plants grown in the outfield compared to plants grown in the homestead. There was no difference in trend between resource endowment categories (Figure 4).

Enset growth and yield

Enset growth was significantly affected by soil fertility gradients. Differences in major nutrient content between the homestead field and the outfield was

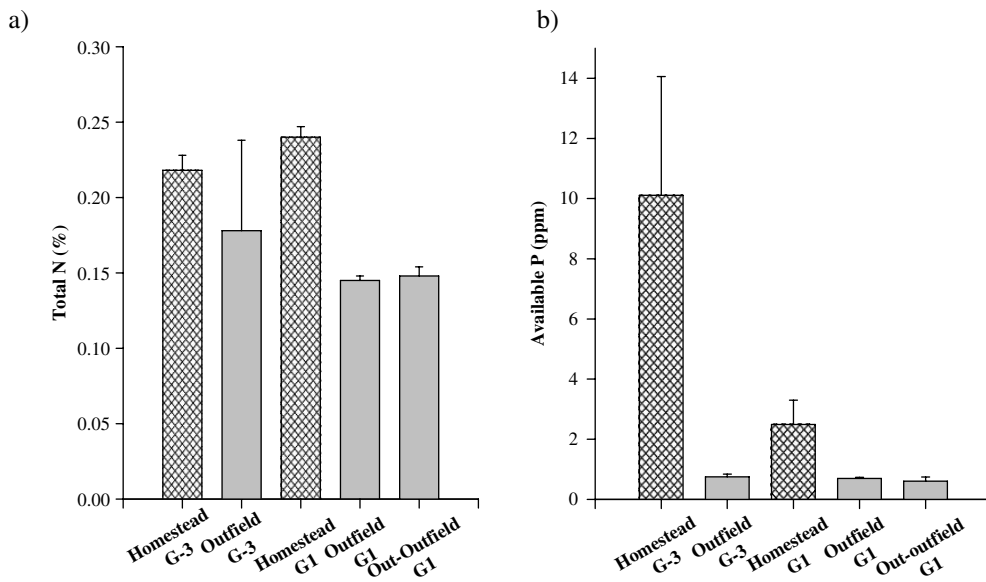

Figure 1. Total nitrogen (a) and available phosphorus (b) content of homestead and outfield soils in farms of resource-rich and resource-poor farmers' fields. Out-out field indicates fields beyond the Enset rows of the outfield. n = 4.

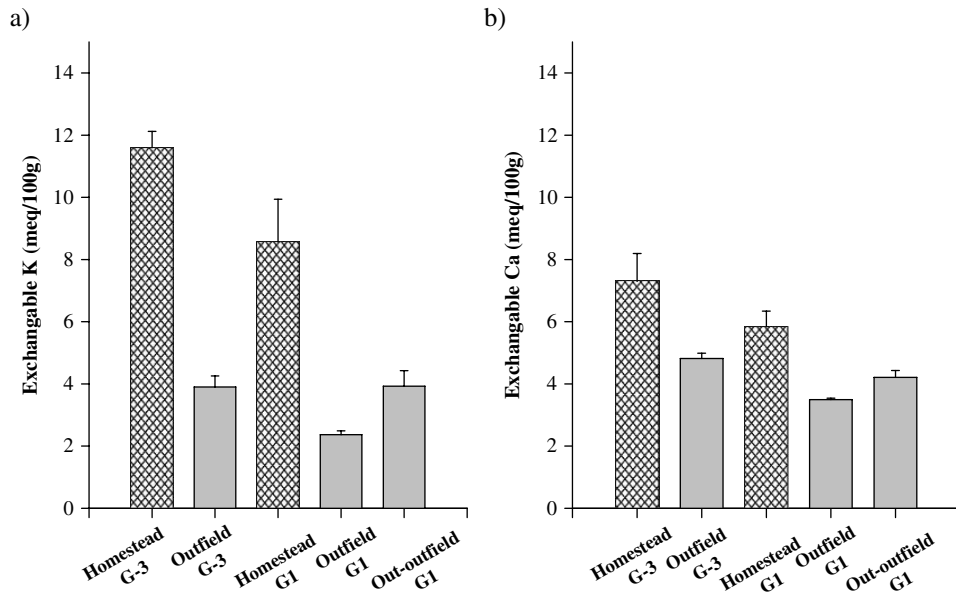

Figure 2. Potassium (a) and calcium (b) content of homestead and outfield soils in farms of resource-rich and resource-poor farmers' fields. Out-out field indicates fields beyond the Enset rows of the outfield. $n = 4$.

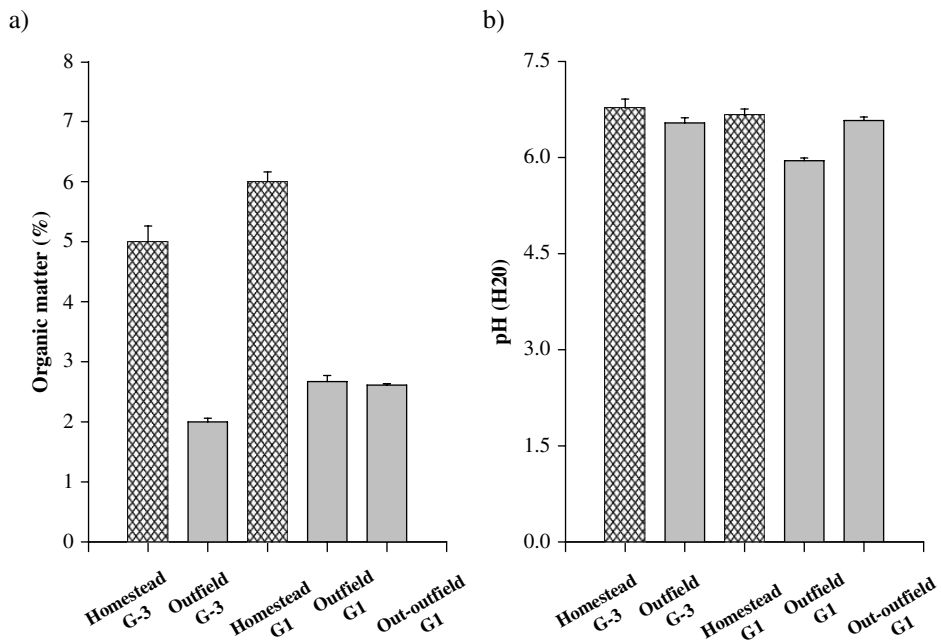

Figure 3. Organic matter content (a) and pH (b) of homestead and outfield soils in farms of resource-rich and resource-poor farmers' fields. Out-out field indicates fields beyond the Enset rows of the outfield. $n = 4$.

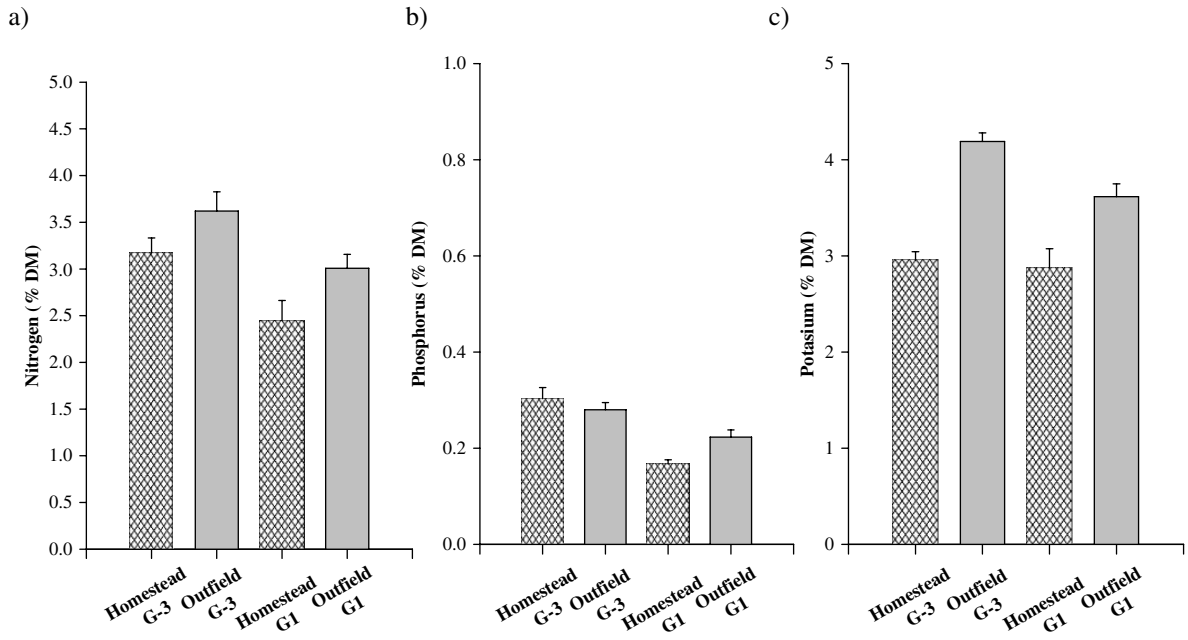

Figure 4. Nitrogen (a), Phosphorus (b) and Potassium (c) content (% of dry matter) of Enset plant tissues grown under homestead and outfield soils in farms of resource-rich and resource-poor farmers' fields. n = 4.

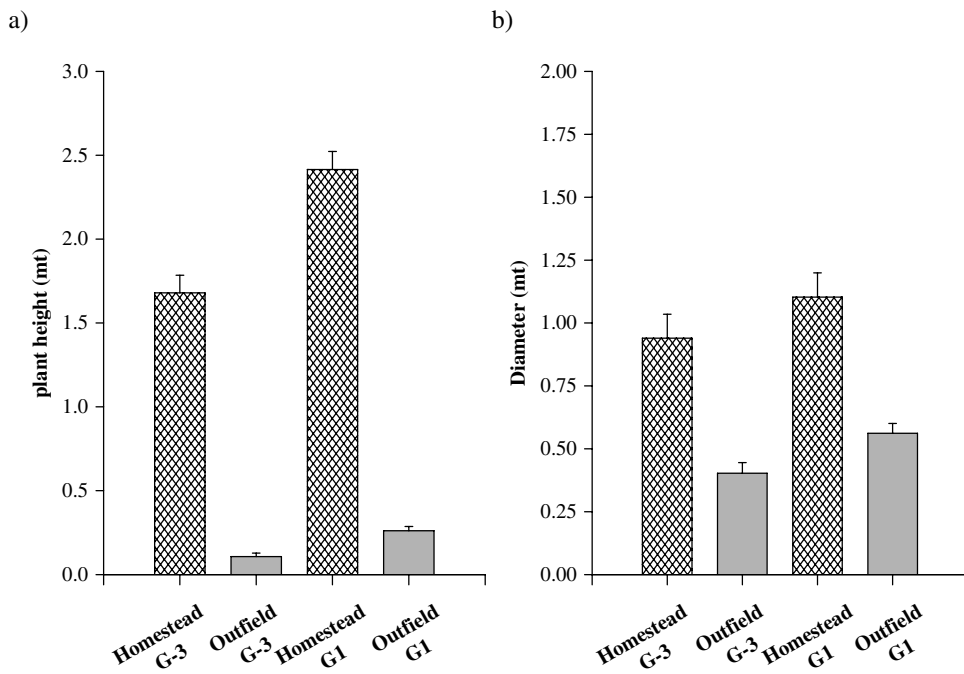

Figure 5. Plant height (a) and Pseudo stem diameter (b) of Enset grown under homestead and outfield soils in farms of resource-rich and resource-poor farmers' fields. n = 4.

strongly correlated to enset growth (data not presented). Enset productivity parameters, height, pseudostem diameter and pseudostem height were severely reduced (Figure 5). Plant height was the most affected by soil fertility gradients, experienced about 90% height reduction, regardless of household resource endowment categories. Similarly pseudo stem diameter was reduced by about 50%. However, enset growth in G1 farm in the homestead was by about 0.8 m higher than that of plant height in G3 farm. Enset growth in the out field of farm G1 was also higher than that of Farm G3.

Discussion

The desire of the town dwellers to shift towards cereals, and the related high market demand for cereal products has been forcing farmers to allocate more land to cereals at the expense of Enset and other perennial crops. On the other hand, as the available land per capita becomes more limited it became a necessity to intensify the systems to produce more food per unit area. Enset is one crop that could enable to feed a household of seven with only about 45 Enset plants per year (Kippe, 2002). Hence, the expansion of Enset from the current number, which is in average 10 mature Enset per household per year to about 30 Enset plants, i.e. a total of about 250 Enset plants of different age per household, would address food security, supplemented by pulses, cereals and other root crops (Amede et al., 2004). This ultimately needs for an expansion of the Enset field to the middle and outfields.

Enset as a major sub-unit has been positively contributing to nutrient cycling (Brandt et al., 1997; Kippe, 2002), as an erosion barrier particularly when it is planted on the top of the farm, and as an incentive to farmers to invest labour and manure. Farmers favour mulching crops like banana and Enset because they know that it suppresses weed growth, maintains soil fertility and conserves moisture for these shallow rooted crops (Bekunda, 1999). On the other hand, the concentration of Enset in the homesteads encouraged a continual nutrient mining of the outfield via crop residues transported as mulch and feed to be used for fertilizing the homestead fields.

The soil nutrient analysis across the gradient showed that soil fertility decline is not global; rather there is a very high difference in nutrient accumulation within the farms, the homestead fields being rich in major

plant nutrients (Figures 1, 2 and 3). The attempt to attract more organic and inorganic fertilizer by planting the most favoured security crop, Enset, in the outfield was not successful as little organic matter was transported to the outfield over time (Table 2). In contrary to the observations of Bekunda (1999), where farmers applied most of the manure for banana in the home fields to reduce the time and effort needed to transport the organic waste to the outfield, the limited transfer of manure to the outfield in the Enset systems of Areka could not be explained by labour shortage, as farmers' did not transport manure to the outfield even in off-season months when labour is abundant (data not presented). Rather, they were investing their family labour to transport crop residues of maize, wheat, and other crops from the out and mid fields to the homestead for mulch and feed (Table 2). The preferential application of the organic waste to the home garden was partly because of the limited manure available due to reduced number of animals and partly as a result of decline in farm size which resulted in fewer opportunities to produce and apply cattle manure and crop residue, as also observed in Uganda (Bekunda, 1999). Households, with no/few animals, lack access to manure as it is becoming an increasingly valuable resource, and not even keen ship or local market can guarantee a supply of it (Eyasu, 2000). But farmers, regardless of wealth groups, initiated three innovation schemes to enhance the management of the outfield. Firstly they have minimized the transportation of crop residues that was taken as mulch (e.g. maize and wheat stover) – with limited feed value- and compost it on the spot to recycle back to the field. Secondly they have been growing N-fixing, fast growing legumes (mainly vetches and stylosanthes) that they have identified earlier (Amede and Kirkby, 2004) as short term fallows and intercrops in the outfields. Thirdly, they have started to construct soil bunds to minimize run-off.

Although the nutrient status of the outfield was significantly lower than the nutrient status of the homestead, which was also reflected by Enset growth, plant analysis showed that there was a very strong accumulation of NPK in the plant tissue of the stressed plants. Accumulation of nutrients under stress conditions could be explained by two possible reasons (Amede and Schubert, 2003). Firstly Enset plants grown in the degraded corners of the farm could be exposed to repeated water stress over the course of the year as the soil water holding capacity, expressed by the low soil organic matter content (Figure 3) is

relatively low. In this case, the domination of external atmospheric deficit over water uptake may lead to a reduction in the expansion rate of the tissue (reduced cell volume), and thereby to an accumulation of cations in the plant cell. Secondly, under moderate levels of stress, roots may still actively absorb nutrients, but they may not be utilized by the plant owing to growth inhibition. Instead translocated ions may accumulate in the cell and induce substantial role in maintaining the turgidity of the plant. Crop growth inhibition, despite sufficient amount of available in the rhizosphere, has been reported (Marschner, 1995). Although Enset is considered as a drought resistant crop that could survive short term dry spells better than annuals (Bayush, 1991) it has got little additional weight beyond survival when planted in outfields. Increased use of chemical fertilizers for Enset in the outfield may not compensate for the manure loss because of the multiple roles the organic waste plays (Brandt et al., 1997), but it could be possible to increase yield in the far out fields by increasing the soil water holding capacity of the soil through increasing the soil organic matter content and reducing the evaporation through mulching low quality crop residues, tree litters and other conservation measures. Although the hypothesis of a U-form relation between population pressure and soil fertility management is not yet observed in the Enset systems, a U-form response is needed to feed the ever growing population.

Acknowledgments

We would like to thank the farmers for professionally managing and monitoring the experiment, Dr Ann Stroud for her continual advice, and Mr Sefene for assisting in data collection. The management of Areka research centre and the African highlands initiative were very supportive to the work.

References

- Amede T. and Kirkby R. 2004. Guidelines for Integration of Legume Cover Crops into the Farming Systems of East African Highlands, pp. 43–64. In: Bationo A. (Ed.) Managing nutrient cycles to sustain soil fertility in Sub-Saharan Africa. Academic Science Publishers, pp. 43–64.
- Amede T., Takele B. and Endrias G. 2001. Reversing the degradation of arable land in Ethiopian Highlands. *Managing African Soils*: No. 23. IIED, London.
- Amede T. and Schubert S. 2003 Mechanisms of drought resistance in grain legumes: Osmotic adjustment. *SINET: Eth. J. Sci.* 26 (1): 37–46.
- Amede T., Stroud A. and Aune J. 2004. Advancing human nutrition without degrading land resources through modeling cropping systems in Ethiopian highlands. *Food and Nutrition Bulletin* 25(4): 344–353.
- Anderson J.M and Ingram J.S.L. 1993. *Tropical Soil biology and Fertility: A hand book of methods*. CAB International, Willingford, U.K.
- Bayush T. 1991. Community management of crop genetic resources in the Enset complex farming systems of Southern Ethiopia. A case study from Sidama region. Unpublished MSc thesis. Agricultural University of Norway.
- Bekunda M.1999. Farmers' response to soil fertility decline in banana-based cropping systems of Uganda. *Managing African Soils* No. 4. IIED-London. 17p.
- Brandt S., Spring A., Hiebsch C., McCabe T., Taboge E., Diro M., Micheal G., Ynitso G., Shigeta M. and Tesfaye S. 1997. The 'Tree Against Hunger': Enset-based Agricultural systems in Ethiopia. American Association for the Advancement of Science. 66p.
- Elias E. 2000. Soil enrichment and depletion in Southern Ethiopia. Pp 65–82. In: Hillhorst, T. and Muchena F. (Eds). *Nutrients on the move: Soil fertility dynamics in African farming systems*, pp. 65–82.
- Kippe T. 2002. Five thousand years of sustainability? A case study of Gedeo land use, Southern Ethiopia. *Tree book 5*, Treemial Publishers, Heelsum, The Netherlands. 261p.
- Marschner H. 1995. *Mineral nutrition of higher plants*. Second edition. Academic press, U.K., 889p.
- Parkinson J.A. and Allen S.E. 1975. A wet oxidation procedure suitable for the determination of nitrogen and mineral nutrients in biological materials. *Communications in Soil Science and Plant Analysis* 6:1–11.
- Tsgaye A. 2002. On indigenous production, genetic diversity and crop ecology of Enset (*Ensete ventricosum*). PhD Dissertation, Wageningen University.198p.

Consequences of Field Management and Soil Erosion on the Sustainability of Large Scale Coffee Farming in Kiambu

Okoth P.F.¹, Ng'ang'a J.K.² and Kimani P.K.²

¹ Tropical Soil Biology and Fertility (TSBF) Institute of CIAT, c/o The World Agroforestry Centre (ICRAF), United Nations Avenue, P.O. Box 30677, Nairobi, Kenya. Telephone: 254-20-524775, Cell: 254-722-768537, Fax: 254-20-524764, Email: p.okoth@cgiar.org; ² Kenya Agricultural Research Institute, National agricultural Research laboratories, Kenya Soil Survey, P.O. box 14733; Nairobi, Kenya.

Abstract

Uncontrolled soil erosion and land degradation affect production systems and are a threat to the sustainability of most agricultural systems. This paper introduces a new management concept; the integrated land use management concept (ILUM), as a means of mitigating against erosion. Large scale coffee estates in Kiambu District, Kenya, were selected for soil erosion investigations through the use of aerial photographs and satellite images. Aerial photographs (1:10,000) were used to delineate coffee field boundaries in the selected sample area after the coffee producing region was delineated using satellite images. Samples collected from the plots indicated pH values of extremely acid to slightly acid soils with deficiencies of Ca, Mg and K. The erosion status varied from slight to severe with the bulk of the fields under moderate to critical erosion severity conditions. A direct relationship between management and nutrient status of the fields, soil erosion status and slope steepness was observed. Liming of the extremely acid soils at 500 g/tree, and the use of SSP and DSP fertilizers is recommended instead of acidifying fertilizers. Mulching is recommended for steep slopes (8–13% and 13–18% slopes). Large fields should be subdivided and Kikuyu grass (*Pennisetum clandestinum*) introduced between the fields as a conservation measure for erosion management and control.

Key words: Integrated Land Use Management (ILUM); Coffee; Sustainability; Conservation; Erosion

Introduction

Uncontrolled soil erosion and land degradation is currently of major concern both globally and in Kenya. Observations in parts of Kenya during the last three decades indicate that the rate of soil loss has been increasing over the years (Dunne, 1974; Edwards, 1979; Amuyunzu, 1989; Biamah, 1986). The harmful effects both in magnitude and extent are not well recognized and quantified in most parts of the country. First, the improved crop production technologies of the late sixties have resulted in increased productivity per unit area, obscuring the destructive effects of soil erosion. Secondly, there is a common notion that

gully erosion is the most damaging form of erosion, thus in areas where gullies do not exist, the damaging effects of soil erosion are ignored (Kiome and Stocking, 1995). Soil loss studies through river sedimentation in the highlands east of the Rift Valley including parts of Kiambu indicate that there are quantified soil losses in many parts of the area. Sediment yields ranging from 20 tons/km²/year in undisturbed forested areas to 3000 tons/km²/year in cultivated and grazing lands have been obtained through river sediment load studies in the past (Dunne, 1974; Dunne and Ogwenyi, 1976; Edwards, 1979; Thomas et al., 1981; Aubry and Wahome, 1983; Barber, 1983). Soil loss studies from runoff plots in Kiambu (Lewis, 1985;

Okoth and Omwega, 1989; Omwega, 1989) indicated that cultivated land loses between 20 and 30 tons $\text{ha}^{-1}/\text{season}^{-1}$ and bare soil loses more than 70 tons $\text{ha}^{-1}/\text{season}^{-1}$.

Most soil erosion studies in the tropics have been short-term, involving measurements of soil erosion rates under different crop and soil management practices (Chinene and Lungu, 1990 cited in Gachene et al. (1997a) and paid little attention to the effects of measured soil loss rates on soil productivity. Several studies have assessed the effect of soil erosion on soil productivity, examples being Salter and Good (1967), Renard and Follet (1985), FAO (1985), Lal (1988) and Sarrantonia and Scott (1988). Gachene et al. (1997a) attempted to fill the gap by carrying out studies on soil productivity loss in Central Kenya. According to them soil erosion affects chemical properties of a soil mainly through the loss of soil organic matter and minerals and the exposure of the subsoil mantle with low fertility and high acidity. The results presented by Frye et al. (1982) on the relationship between soil loss and soil productivity indicate that erosion causes considerable deterioration in soil fertility and decline in crop yields. To assess soil loss research on run-off plots in Kiambu have been carried out in which losses of plant nutrients due to erosion can be assessed using enrichment ratios (Okoth and Omwega, 1989; Gachene et al., 1997a; Ongwenyi, 1978). These studies show that nutrients such as phosphorous, organic carbon, calcium, manganese, nitrogen and sodium are the most affected due to loss of topsoil caused by erosion. Further, pH values are lowered making the soils acidic.

Mitigating factors for soil erosion control are soil conservation practices and good crop husbandry practices. In a study carried out at Mathioya, Murang'a District, Ongwenyi (1978) observed that if crop management and agricultural practices included soil and water conservation (i.e., C and P factors in the universal soil loss equation) as well as supporting practices such as contouring, sediment losses individual crops were almost reduced by half. Further, planting of crops in rows along the contour as opposed to planting down-slope greatly reduced the extent of erosion. If crops are grown on ridges along the contour, the erosion hazard from run-off can effectively be reduced. If mulching, terracing or both support the planting methods, the soil erosion can be reduced to its bare minimum.

An integrated land use management (ILUM) is explored in this paper. The distinction between land use and integrated land use management is that, whereas land use describes only the use to which a piece of

land is kept, integrated land use management refers to additional appropriate interventions in its use that ensure conservation and sustainability. For distinction, Tiffen et al. (1994) defined *conservation* as the retention of soil and water in places useful to man through the creation of structures, and *sustainability* as the maintenance or improvement, over several years (of fluctuating rainfall), of soil chemical and physical properties on cultivated land, or of pasture productivity on grazing land. Soil and water conservation on the other hand refer to the execution of measures aimed at the prevention, reduction and regeneration of harmful losses of soil, water, and nutrients on sloping land. Integrated management in this definition refers both to the agronomic and husbandry practices necessary to maintain and ensure sustainability of a crop. Another inclusion into the integrated management terminology is the use of conservation structures, contour tillage, ridge planting, strip cropping and terracing as a basis of soil and water retention on required parts of the terrain. Good soil fertility maintenance is also necessary (Pereira and Jones, 1950).

In Kiambu, the problem of soil erosion is obscured by the fact that on a casual view of the landscape, one might think that there is no continuous soil erosion. Apart from the lower lying areas with lower annual rainfall, most of the Kiambu district receives an annual rainfall higher than 800 mm up to a maximum of 2000 mm. This has contributed to a high degree of vegetative vigor and cover in the steeper parts of the district, which are also the areas that suffer the higher risk of soil erosion. The areas appear stable from superficial observation, while in reality they are not.

As already stated, soil erosion in Kiambu district appears not to be well appreciated due to its invisibility in the landscape. The belief by many and from earlier soil erosion research reports is that coffee and tea (*Camelia siniensis*) protect the land and only induce minor erosion (e.g., Lewis, 1985). By coincidence, coffee and tea cover nearly 55% of the land area of Kiambu (Wiegers, 1995). Evidence from the latest field observations (this paper) show, that on certain slopes and slope positions coffee and tea induce a relatively high rate of soil erosion.

The objectives of this study were therefore: (1) to document the degree of soil erosion in some large scale coffee estates in Kiambu district; (2) to evaluate the role of agronomic management practices, slopes, and conservation measures for their influence in the occurrence of soil erosion in the large coffee estates; and (3) to show the impacts of soil erosion

on soil productivity and coffee yields and, hence, the consequence of erosion on the sustainability of the soil resource.

Materials and methods

Location

Kiambu district is situated in the Central Province of Kenya. It lies between latitudes $0^{\circ} 46' S$, and $1^{\circ} 31' S$ and longitudes $36^{\circ} 30' E$ and $37^{\circ} 20' E$. It borders Nairobi to the south, Muranga district to the North, Machakos to the East and Nakuru and Nyandarua districts to the West. Location of Kiambu district in Kenya is shown in Figure 1.

The large scale coffee estates of Kiambu are situated on the lower parts (1630–1650 m a.s.l.) of the district and occupy more than 75,000 hectares (Wieggers, 1995). Compared to the small-scale coffee region (1650–2200 m a.s.l.), the mean annual rainfall in the large scale coffee region is lower (750–950 mm). Therefore, in the drier periods, rainfall tends to be insufficient and erratic making irrigation essential. Overhead irrigation methods are employed. Due to the low altitude, pests and diseases (e.g., berry borer and leaf rust) are prevalent. Figure 1 shows the location of the study area.

Climate

Rainfall is largely influenced by altitude (Sombroek et al., 1980). The mean annual rainfall therefore varies from 500 mm in the lower areas around Thika, increasing gradually to 1500 mm in the upper region of the district. The highest rainfall is recorded on the Kikuyu escarpment to the North and decreases progressively towards the low lying areas of Munyu-Ngoliba to the South-East and Ndeiya-Karai to the South-West. The mean maximum temperature ranges from $26\text{--}28^{\circ} C$ in the East and the South, and $18\text{--}20^{\circ} C$ in the Northwest. The mean minimum temperature ranges from $14\text{--}16^{\circ} C$ in the Eastern and Southern parts, and $6^{\circ}\text{--}8^{\circ} C$ in the Northwest (Kinangop area).

Soils of the study area

According to Shitakha (1983), the soils of the areas under coffee cultivation are well drained, strongly weathered, extremely deep and dark red to dark reddish brown friable clay soils with an ABC sequence of horizons. The topsoil has medium, moderately strong, sub-angular blocky structure while the B-horizon has

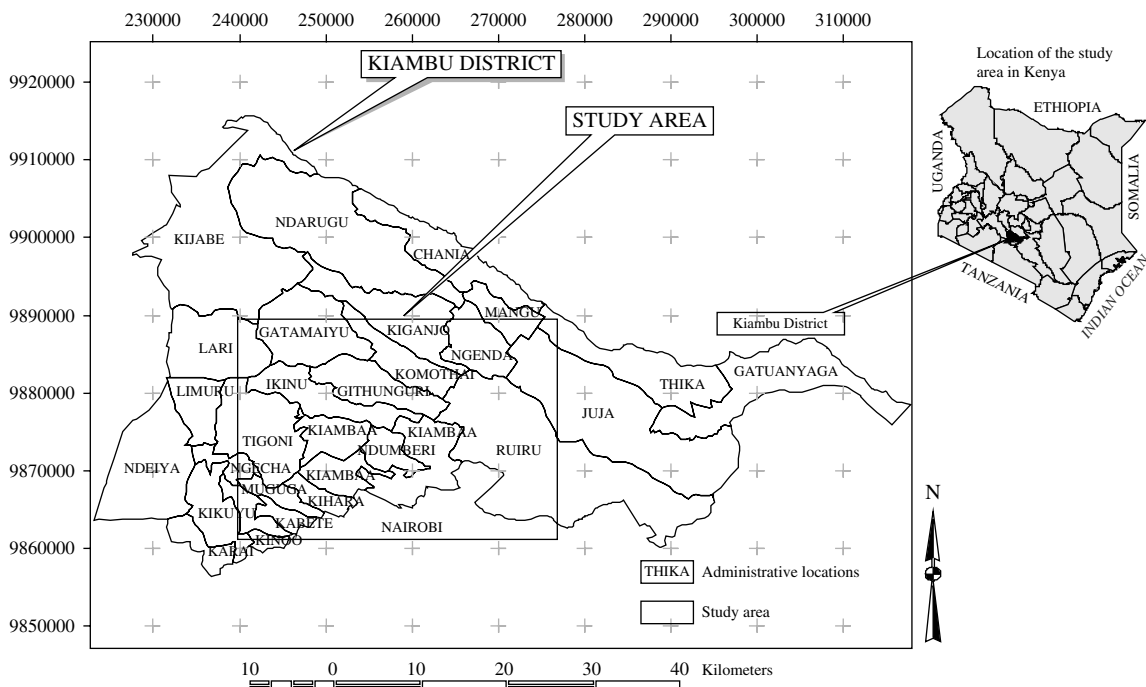

Figure 1. Location of the study area in Kenya and parts of Kiambu and Nairobi districts.

the same structure supplemented with medium, moderately strong, angular blocky structure. The topsoil is friable when moist and sticky and plastic when wet, while the B-horizon is slightly hard when dry, friable when moist, sticky and plastic when wet. The soils are generally slightly acidic with pH values range from 6.0 to 6.6 in the topsoil and from 5.1 to 6.6 in the B-horizon. CEC varies between 19 and 34 me/100g in the topsoil and between 10 and 28 me/100g in the B-horizons. The soils classify as Mollic and Humic Nitisols in the FAO-UNESCO "Soil Map of the World" (1974) classification.

Methodology

General

Three methods were used to collect data. Direct observations in the field, questionnaires on field plot management and field sample collection for analysis in the lab. Vegetation and land use data of the study area were obtained from existing reports, maps and satellite images. LandSat Thematic Mapper images acquired in January 1995 were used as the primary source of boundaries for land cover/use units. After field descriptions, further analysis gave nomenclature of the units. Okoth (1998) has given a detailed description of the land use types in Kiambu. After the delineation of the coffee zone, a sample area from the zone was selected for more detailed studies and analysis. Aerial photographs (scale 1:10,000) were used to delineate individual coffee field boundaries. The following field data was then acquired from 28 observation sites:

Detailed methodology

Management conditions

The management conditions that were considered include, (a) agronomic management of the coffee fields, which included type of fertilizer used, the amount applied, method of traction and tillage, crop spacing, the type of weeding, and the spraying regimes, and, (b) soil conservation measures employed, which included mulching and the use of wash pits which appeared to be the dominant form of conservation measures in the coffee fields.

The management attributes used to assess the impact of the agronomic measures in the study included planting distance, fertilizer amount applied, weeding, and spraying. According to findings by Stocking (1988), all attributes of agronomic measures impact on the vigor of vegetative growth of the crop. Their impact can therefore be inferred from the crop canopy cover (this paper). Findings relating crop growth, crop canopy cover and crop yield to agronomic measures have been reported before (Omweaga, 1989; Gachene et al., 1997b; Gicheru et al., 1998).

In this study, crop canopy cover was used for rating the degree of agronomic measures applied, which is considered to include all the mentioned management attributes. In integrated land use management, agronomic measures are assigned a score rating; then the individual ratings are summed up with those of conservation measures to obtain the final integrated land use management (ILUM) measure rating (Table 1). In this paper, the soil and water conservation measures evaluated were: (i) percentage cover of mulch and trash on the measurement site, and (ii) the spacing of wash pits between the coffee trees. The attributes: canopy cover, mulch, trash-lines, and wash pit spacing were evaluated and rated according to knowledge and evidence obtained from the field on their efficacy for erosion control. The ratings were then summed up and a final classification rating allocated to each of the selected integrated land use management attributes. Table 1 shows the individual, summed ratings and a final classification rating for the integrated land use management factor (ILUM).

For data collection, the slope categories were grouped into seven categories: 0–2%; 2–5%; 5–8%; 8–13%; 13–18%; 18–30%; >30%. Only 5 categories were prevalent in the sampled area, i.e., 0–2%; 2–5%; 5–8%; 8–13% and 13–18%.

The soil properties assessed and determined through laboratory analysis were pH, available phosphorous (P₂O₅), available potassium (K), exchange capacity (EC), calcium (Ca) and manganese (Mg). Other data collected included field plot erosion status according to Table 2 and coffee yields, obtained from green berries of three straight coffee tree branches per site, which were averaged for each site.

The attributes used to describe erosion were soil movement, surface litter, root exposure, stem washing, flow patterns, and rills. Gullies were not included since they did not occur in the coffee estates. The classification followed a modified erosion condition classification system as described by Clark (1980). The

Table 1. Rating of the individual management attributes.

Management attributes classification	Very Good	Good	Moderate	Poor
Agronomic:				
Crop canopy cover (%)	> 65	65–55	55–45	<45
Ratings	1	2	3	4
Conservation measures:				
Mulching + Trashlines (%)	> 80	80–70	70–60	< 60
Ratings	1	2	3	4
Distance between wash pits (m)	2–3	3–6	6–9	> 9
Ratings	1	2	3	4
Final Summed score rating	3–4	5–7	8–9	10–12
ILUM category classification	1	2	3	4

Slopes Sampled.

individual attributes were assigned a risk factor depending on the erosion category and were summed up to obtain the final erosion class based on observed field evidence and knowledge. The following erosion classes were used: stable, slight, moderate, critical and severe. Table 2 shows the individual summed up ratings, the erosion evidence categories used for the ratings and the final erosion classification ratings.

Sample analysis

Particle size distribution in soil samples was determined by the hydrometer method (Black, 1965). Chemical analysis was carried out on soil samples with a particle size <2.0 mm using standard methods as described by Hinga et al. (1980). Organic C was determined using the Walkley and Black method (Walkley and Black, 1934; Black, 1934); soil pH was determined in 1:2.5 soil–water suspension; available P was determined by the molybdenum blue/ascorbic acid method (Mehlich et al., 1962) and K by flame photometry.

Results and discussion

Severity of erosion varied in the study area indicated by different values obtained from different sites. Results indicate that many of the sites suffered slight to moderate erosion, although critical and severe erosion conditions were also observed in five sites (Table 3c). The analysis of soil samples from the study area are presented in Table 3a. The dataset indicate soil acidity ranged from extremely acid soils (pH 3.8–4.5) to

slightly acid soils (i.e., pH 5.0–6.2). From the same data, most of the soils appear to have been deficient in some required plant nutrients for coffee i.e., Ca, Mg and K (Table 3a). Soil potassium (K) shows the highest deficiency with no site having sufficient amounts. Organic matter was fairly well occurring in the soils (adequate) with values ranging from 2.3 to 3.5 gm kg⁻¹). The occurrence of organic carbon in such amounts indirectly indicates the supply of nitrogen (N) in the soils. In this case, available nitrogen was not determined during laboratory analysis. As observed from the soil chemical data and the allocated management categories there exists a relationship between the management inferred from ILUM and the erosion status of the observed sites (Table 3b with correlation statistical analysis). ILUM was found to correlate positively with the erosion class showing that better managed sites suffered less erosion than the less well managed sites. Table 3a shows the relationship between slope class, ILUM (management), erosion and soil chemical properties. The table indicates that the poorly managed plots are directly affected by soil erosion. Out of the six poorly managed plots, four plots were rated in erosion class 3 to 5 (moderate to severe erosion). Where management was poor (ILUM class 4), even gentle slopes with 2–5% were rated in erosion class 3, which is critical. Where management was good (ILUM class 2), the erosion status was slight (erosion rating 2). For steep slopes (8–13% and 13–18%) where management was rated as good (ILUM class 2 and 3), the erosion status was slight to severe (erosion class 2 and 4).

For slopes where management was rated as moderate (ILUM class 3), the erosion status ranged from

Table 2. Soil water erosion classification system based on field observations in Kiambu.(Modified after the Clark 1980 classification system).

Erosion Feature	Erosion Severity Class				
	Stable	Slight	Moderate	Critical	Severe
Soil movement (cm)	0–1.5	1.5–3.0	3.0–5.0	5.0–8.0	> 8.0
Rating	1	2	3	4	5
Surface litter (%)	0–2	2–10	10–25	25–50	>50
Rating	1	2	3	4	5
Root exposure (cm)	0–0.5	0.5–2.0	2.0–3.0	3.0–5.0	>5.0
Rating	1	2	3	4	5
Stem washing (cm)	0–1.0	1.0–3.0	3.0–5.0	5.0– 7.0	>7.0
Rating	1	2	3	4	5
Flow patterns (%)	0–2	2–10	10–25	25–50	> 50
Rating	1	2	3	4	5
Rills:					
Depth (cm)	1–41	4–8	8–12	12–20	> 20
Rating	1	2	3	4	5
Width (cm)	< 10	10–25	25–45	45–80	> 80
Rating	1	2	3	4	5
Frequency (m)	10–5	5–4	4–3	3–2	> 2
Rating	1	2	3	4	5
Range totals	3–4	5–7	8–10	11–13	14–15
Final Rating	1	2	3	4	5
*Gullies:					
Depth (cm)	15–35	35–55	55–75	75–95	> 95
Rating	1	2	3	4	5
Width (cm)	30–60	60–100	100–150	50–15	15–5
Rating	1	2	3	4	5
Frequency (m)	> 500	500–150	150–50	50–15	15–5
Rating	1	2	3	4	5
Range totals	3–4	5–7	8–10	11–13	14–15
Final Rating	1	2	3	4	5
Erosion class, totals	6	12	18	24	30
range totals (exc. Gullies)	6–8	9–14	15–20	21–26	27–30
Final Erosion Class Rating	1	2	3	4	5

*Gullies were absent in the coffee estates and were not included in the erosion classification.

moderate to critical (class 3 to 4). Normally, this occurred on the lower parts of the slope (slope position *l*), (Table 3a). From field observations, these slope positions had the highest run-off impact due to the high velocity of the flowing water and the cumulative effect of concentrated flow from several rills or stream channels. Observation sites that had good management (i.e., ILUM class 2 and above) had higher pH values that ranged from 4.33 to 5.77 except one site that had a pH of 3.79. It is evident from Table 3a, that where management rating was poor (ILUM class 4), pH values were likewise very low ranging from 3.82 to 3.89. The same trend occurred for magnesium, calcium and

potassium. Phosphorous was generally in excess and well supplied in all the soils of the study area. This was mostly likely due to the excessive use phosphorous fertilizers in many of the coffee farms. From the statistical analysis presented in Table 3b, there was good correlation between soil pH, soil K, soil P, soil Ca and soil Mg. This may be attributed to the fertilization regimes by the said nutrients. This has a direct consequence on the soil pH. The occurrence of high organic matter in the soils could be attributed mainly to the intensity of mulching with grass or coffee leaf-prune mulches. This is a commonly used water conservation measure in the area.

Table 3a. Relationships between slope classes, ILUM, erosion severity classes and soil chemical properties.

Observation No.	Slope class	Slope pos.	ILUM class	Erosion class	Yield per tree (gm)	pH	P mg/kg	K mg/kg	Ca mg/kg	Mg mg/kg	C gm/kg	EC mmhos/cm	N gm/kg
97182/14	0-2	u	2	2	465	4.5	139	0.18	1.00	0.34	3.32	0.40	-
97182/13b	2-5	u	2	1	504	4.3	152	0.1	1.25	0.11	3.39	0.36	-
97181/7s	2-5	u	3	2	262	4.8	47	0.1	0.75	0.68	2.40	0.31	-
97181/1	5-8	u	2	2	-	-	-	-	-	-	-	-	-
97182/18	5-8	u	3	2	168	5.2	34	0.18	1.50	1.54	3.28	0.45	-
97182/11b	5-8	u	3	2	202	5.2	39	0.15	1.25	1.49	2.76	0.24	-
97182/10b	5-8	u	3	3	238	0	0	0	-	-	-	-	-
97182/17	5-8	u	3	3	182	6.2	30	0.18	2.75	2.42	3.35	0.60	-
97182/16	5-8	u	3	3	265	-	-	-	-	-	-	-	-
97181/85-8c	u	3	3	299	4.1	108	0.1	0.75	tr	2.27	0.30	-	-
97181/9	5-8	u	4	3	224	3.9	137	0.08	0.75	tr	2.27	0.30	-
97182/8b	8-13	u	2	2	147	3.8	121	0.1	0.75	tr	3.54	0.91	-
Average values for the upper slopes					269	4.7	90	0.13	1.19	1.1	2.95	0.43	
97182/17b	0-2	m	3	2	234	6.2	30	0.18	2.00	2.53	3.02	0.31	-
97181/2b	2-5	m	4	1	-	-	-	-	-	-	-	-	-
97182/15	5-8	m	3	3	-	5.3	99	0.15	1.50	2.16	3.34	0.37	-
97181/10c	5-8	m	4	2	248	3.9	49	0.08	0.75	tr	1.93	0.48	-
Average values for the mid slopes					241	5.1	59	0.14	1.42	2.35	2.76	0.39	
97182/18b	2-5	l	2	1	147	5.8	14	0.2	1.25	1.84	2.60	0.26	-
97182/15b	2-5	l	4	3	180	4.6	44	0.1	0.75	1.85	2.58	0.29	-
97182/11	5-8	l	2	1	53	5.1	33	0.13	1.50	1.52	3.06	0.23	-
97181/8s	5-8	l	3	4	305	5.9	77	0.2	1.75	4.52	2.76	0.31	-
97181/10s	5-8	l	3	2	379	4.3	145	0.08	0.75	tr	2.99	0.28	-
97181/7b	5-8	l	3	2	226	4.7	69	0.1	0.75	tr	1.67	0.57	-
97182/16b	5-8	l	4	4	278	4.6	44	0.1	0.75	1.85	2.58	0.29	-
97181/9b	5-8	l	4	5	325	3.9	228	0.08	0.75	tr	2.25	0.29	-
97182/10	8-13	l	3	4	73	5.8	73	0.1	1.75	2.45	3.13	0.35	-
97182/13	8-13	l	3	3	319	-	-	-	-	-	-	-	-
97182/8	>13	l	2	2	55	5.4	7	0.13	1.25	1.63	2.37	0.31	-
97182/14b	>13	l	3	4	135	4.6	25	0.1	0.75	1.50	2.28	0.22	-
Average values for the lower slopes					206	5.0	69	0.12	1.09	2.15	2.57	0.31	
Optimal nutrient requirements for coffee						4.4-5.4	20-100	0.4-2.0	1.6-10	0.8-4			2.0-3.0

C = Soil Organic Carbon-Walkley and Black method (Black, 1965); P = Soil Phosphorous (Mehlich et al., 1962); pH pH = soil pH (1:2 soil to water ratio) K = Soil Potassium (Flame photometer method); Ca = Soil Calcium (Ammonium acetate method, pH 7); C = Soil Electrical Conductivity (1:1.5 soil:H2O ratio); slope pos.= slope position; m = mid-slope; l = lower u = upper slope; erosion severity class 1 = less severe, class 4 = very severe.

Table 3b. Correlation coefficients between the slope class, slope position, erosion class, yield, and the soil chemical properties derived from Table 3a.

	ILUM	ERoS C	SlopeC	SlopeP	Yield	pH	P	K	Ca	Mg	SOC	EC
ILUM	1.00	.49**	.32	-.17	.06	-.37	.12	-.39	-.23	-.03	-.45*	-.17
ERoS C	.49**	1.00	-.01	-.27	.01	-.21	.25	-.21	-.04	.25	-.21	-.14
SlopeC	.32	-.01	1.00	.23	.23	-.17	.15	.01	-.00	-.07	-.18	-.15
SlopeP	-.17	-.27	.23	1.00	.27	-.01	.16	.11	.09	-.30	.32	.34
Yield	.06	.01	.23	.27	1.00	-.34	.65**	-.10	-.23	-.34	.10	-.05
pH	-.37	-.21	-.17	-.01	-.34	1.00	-.39*	.66	.74**	.56**	.28	-.06
P	.12	.25	.15	.16	.65**	-.39*	1.00	-.41	-.35	-.53**	.10	.11
K	-.39*	-.21	.01	.12	-.08	.66**	-.41*	1.00	.69**	.66**	.44**	-.02
Ca	-.23	-.04	-.00	.09	-.23	.74**	-.35	.69	1.00	.69**	.54**	.08
Mg	-.03	.25	-.07	-.30	-.34	.56**	-.53**	.66	.69**	1.00	.27	-.24
SOC	-.45*	-.29	-.18	.32	.100	.28	.10	.44	.54**	.27	1.00	.28
EC	-.17	-.14	-.15	.34	-.05	-.06	.11	-.02	.08	-.24	.28	1.00

ILUM = integrated land use management; ERoS C = erosion class; SlopeC = slope class; SlopeP = slope position; SOC = soil organic carbon; ** = correlation is significant at the 0.001 level; * = correlation is significant at 0.05 level.

Table 3c. Comparing slope class, slope position, obtained yields, ILUM (management class) and erosion severity class.

Observation No	Slope class	Slope position	Yield*(g/tree)	Yield Difference (%)	ILUM	Erosion severity class
97181/8c	5-8	U	299.4		3	3
97182/10b	5-8	U	237.7		3	3
97182/11b	5-8	U	201.7		3	2
97182/13b	2-5	U	504.2		2	1
97182/14	0-2	U	465.2		2	2
97182/18	5-8	U	168.4		3	2
97181/9	5-8	U	224.1		4	3
97182/8b	8-13	U	146.9		2	2
97181/7s	2-5	U	261.9		3	2
97182/16	5-8	U	264.8		3	3
97182/17	5-8	U	181.5		3	3
97181/10c	5-8	M	247.7		4	2
97182/15	5-8	M	-		3	3
97182/17b	0-2	M	234.0	+22	3	2
97181/8s	5-8	L	304.5	+2	3	4
97182/10	8-13	L	73.0	-69	3	4
97181/10s	5-8	L	378.9	+35	3	2
97182/11	5-8	L	53.1	-74	2	1
97182/13	8-13	L	319.1	-37	3	3
97182/14b	13-18	L	134.6	-71	3	4
97182/18b	8-13	L	146.9	-13	2	1
97181/9b	5-8	L	325.2	+31	4	5
97182/8	13-18	L	55.0	-63	2	2
97181/7b	5-8	L	226.3	-14	3	2
97182/16b	5-8	L	278.2	+5	4	4
97182/15b	2-5	L	180.4	-	4	3

M = mid-slope; L = lower slope; U = upper slope; erosion severity class 1 = less severe, class 4 = very severe.

According to Wrigley (1988), a soil acidity of pH 5.8-6.0 appears to be the limit for good root growth, though roots occur in more acid soils. The Coffee Research Foundation (CRF) Ruiru give the lowest and upper pH limits as 4.4 and 5.4, respectively. From the ILUM data, the well-managed coffee estates are within the CRF ranges as compared to the poorly managed coffee estates. Other nutrients like Ca, K, and Mg even though deficient in nearly all of the coffee estates, are slightly higher in soils of the well-managed estates (ILUM class 2).

Table 3a and 3c show that lower slope positions lower yields of coffee compared to the upper or middle slope positions in a single field. Coincidentally the lower slope positions were steeper with gradients varying between 5 and 18% compared to the upper slopes with values ranging from 0-8% slopes. The coffee productivity differences could be attributed to biased management that mostly favored the upper slopes due to their gentler gradients and ease of access. Lower productivity on the lower slopes was further worsened

by higher rates of erosion. Generally, the more gentle slopes retain more soil moisture and nutrients due to higher rates of vertical infiltration as opposed to higher surface water translocation on the steeper slopes.

All in all, out of the twenty eight observations, it was only in four cases where the trends reported on yields differed. Site 97181/8s, 97181/10s, 97181/9b, on lower slopes and site 97181/17b, a mid-slope site, obtained higher yields than on the respective upper slope positions. It is likely that in these cases, nutrients were translocated from the upper mid-slopes and retained on the lower part of the slopes where the obtained yields were higher. Otherwise the higher p levels could be due to higher application rates of the phosphate fertilizers than the corresponding upper slope positions as shown by higher values of P in Table 3a. Previous studies (e.g., Okoth and Omwega, 1989), found that selective translocation of the finer clay particles occurs from higher slope positions to lower parts in an erosion event. This migration of clay might result in a degradation of the topsoil of the upper slope and an enrichment of the

lower parts. This theory is supported by the chemical properties of the topsoil for three out of the four sites on higher slopes (Table 3a). The pH, P-content and C-content of sites 97181/8c, 97181/10c and 97181/17 on upper and the mid-slopes had lower values compared to the values of lower slope positions (i.e., 97181/8s, 97181/10s and 97181/17b (Table 3a)). An exception occurred in the upper slope on site 97181/8c, where the P-content was 108 mg/kg that was higher than many other sites in the mid-slope and lower slope positions. This condition was magnified where the gradients were also high. Where the gradients were lower (i.e., slope gradients less than 5%) the situation reversed and the lower positions had better yields.

Previous works investigating the effect of management and soil erosion on crop yields showed a direct relationship between management practice and obtained crop yields. Examples include the works by: (Lal, 1988; Larson and Pierce, 1991; Gachene et al., 1997b; Gicheru et al., 1998; Castillo et al., 1997; and Helming et al., 1998).

The effect of different agronomic measures was demonstrated by the results obtained for sites 97182/14, 97182/18b and 97182/13b (Table 3a). Although the three sites were rated in ILUM class 2 and in erosion severity class 2 (site 97182/14), and severity class 1 (sites 97182/18b and 97182/13b) respectively, the berry yield on sites 97182/14 and 97182/13b were 465 g and 504 g compared with 147 g at site 97182/18b. The high yield difference between the plots was explained by the fact that sites 97182/14 and 97182/13b belonged to one farmer (Socfinaf-Oakland Farm) who applied 200 g/tree of NPK, 150 g/tree of CAN and 100 g/tree of DAP fertilizers and 20 tons of manure per year. Site 97182/18b belonged to a different farmer (Bradgate Farm), who applied 150 g/tree of NPK and 100 g/tree of CAN or ASN fertilizers but did not add any manure. Another influence of management is observed in the Socfinaf-Oakland farm where site 97182/18b belonging to ILUM class 2 and erosion class 1, similar to site 97182/13b, site 97182/13b produced higher yields due to the application of higher quantities of mineral fertilizers and farm yard manure than site 97182/18b that had similar erosion severity class (Erosion severity class 1). The yield increased by a factor of 3–3.5 indicating the importance of adequate agronomic measures. The other difference between the two sites was that site 97182/13b was on the upper slope and more accessible for management. The results show the importance of integrated land use management in that, while the physical conservation measure using mulch

reduced the risk of erosion, it did not directly result in higher yields. Conservation measures must therefore be coupled with adequate fertilization and irrigation to obtain the desired yield levels. Due to higher fertilizer inputs, Socfinaf-Oakland farm obtained about two tons of clean coffee per hectare compared to 1.2 tons per hectare obtained by the Bradgate Farm. The undesirable effects of erosion were shown by the results obtained at sites 97182/14 and 97182/14b in the Socfinaf-Oakland farm. Site 97182/14, located on a more gentle slope (0–2%) and rated in erosion severity class 2 received the same agronomic management as site 97182/14b (slope 13–18%), but the latter suffered severe erosion (class 4) due to inadequate application of conservation measures. On this steeper site (ILUM class 3), yields were lowered by 71% compared to the upper slope site 97182/14 (ILUM class 2), which was conserved with adequate amounts of grass mulch. The soil nutrient content was also depleted at the steeper site, which further indicates the need for more integrated management to ensure higher yields.

Conclusion

The study concluded that most of the soils showed pH values lower than the optimum range for coffee (5.8–6.0). Only two sites had pH values higher than 6.0. This contributes to a depression of coffee productivity and necessitates action to alleviate the problem. Most of the soils were deficient in Ca, Mg, and K, leading to an imbalance in the micro-nutrient uptake by the crop. The soils were sufficiently supplied with P due to excessive use of phosphate fertilizers. Organic matter was well supplied to the soils. However, it is not clear, which proportions contribute to optimal N-availability for uptake by the crop. Most of the organic matter might have been present in the form of lignified material, which is not easily converted into organic matter fractions from which N-release for plant uptake occurs. This aspect requires further studying for best strategies.

As pertains to the soil erosion, the study concluded that well-managed gentle slopes (0–5%) suffered the least erosion. Slopes ranging from 5–18% suffered the highest water erosion (moderate to severe), including rills, exposed stems and roots, translocated surface litter, flow patterns and soil movement. The plots without integrated agronomic and conservation measures suffered the highest erosion risk.

Field plots receiving good conservation measures but less agronomic management suffered less from erosion but gained lower yields. Plots receiving good agronomic management but less conservation measures suffered higher erosion and yield declines, especially on steeper slopes. Plots receiving good agronomic and conservation measures suffered the least erosion and had the highest crop yields, despite steep slope gradients.

In general coffee plantations cannot be recommended on slopes exceeding 15%, due to the high hazard of erosion and productivity decline. To obtain optimum productivity and sustainability in such environments, very high inputs of labor, mulch material, conservation structures, fertilizer and irrigation are required. Farmers might not be aware of the need for an integrated land use management approach as a means of increasing their yields and conserving the soils.

The study recommends that the soil resource as the growing medium for coffee and other crops needs to be well managed to ensure continuous production. The soil pH and the nutrient contents need to be raised to achieve optimum productivity and sustainability. We recommend liming not only because coffee prefers a less acid soil but also to provide for the fairly high calcium and magnesium requirements of the crop. Liming or organic amendments are recommended on a yearly basis until the optimum soil pH of 5.8–6.0 is attained. Per tree, 500 g/year of liming material should be incorporated at 20 cm soil depth to achieve the desirable pH (5.4–6.5). Where calcium and magnesium is deficient, the use of Ca-based and Mg-based liming materials are recommended, or the use of a fertilizer containing both Mg and Ca (e.g., Dolmax).

Where pH values are strongly acid to extreme acid (pH < 4.4), single or double super phosphate (SSP, 18–22% P₂O₅) and (DSP, 46% P₂O₅) should be applied at the rate of 350 g/tree for SSP and 150 g/tree for DSP. The same is recommended for moderately acid conditions (pH 4.4–5.4). For mildly acid soils (pH > 5.4) Di-ammonium phosphate (DAP) should be used at a rate of 150 g/tree.

In order to maintain and sustain productivity, adequate amounts of NPK fertilizer should be used. To attain 1.5 to 2.0 tons/ha of clean coffee, NPK (26% N) should be applied at 500 kg/ha/year or 380 g/year/tree. For yields > 2 tons/ha of clean coffee, NPK should be applied at 750 kg/ha/year or 600 g/year/tree. The fertilizer recommendations are based on a planting density of 1330 trees/ha or 2.74 x 2.74 m² spacing. Where low

values of organic carbon have been recorded, it is recommended to apply of 20 tons/ha of organic manure; where moderate values of organic carbon have been recorded, 10 tons/ha of manure should be applied.

The soils should be well conserved by the use of mulch, trash and wash pits. Where the fields are too long (> 50 m) especially on sloping parts, they should be segmented by planting Kikuyu grass (*Pennisetum clandestinum*) as a conservation measure. Terracing could also be used where slopes are too steep (> 8%).

Large-scale coffee farmers should be made aware of and educated on the advantages of using integrated land use management measures on their fields.

Farmers should regularly test and monitor their soils for nutrient status and erosion conditions in order to manage their farming enterprises more profitably and sustain soil productivity.

Acknowledgements

The authors of this paper wish to acknowledge the Netherlands Government, the IDA and KARI for financial and administrative support to carry out this work. We also would like to thank the commercial farmers of Kitamayu, Socfinaf (Oacklands) and Mbo-I-Kamiti (Bradgate) Coffee Estates, for allowing us access onto their farms and facilitating sample collection. The contribution of all staff of Kenya Soil Survey who assisted in one way or another in the execution and finalization of this work is highly acknowledged. Finally, we wish to thank the AfNet Coordinator for allowing us to present this paper AfNet Symposium in Cameroun.

References

- Amuyunzu C.L. 1989. Soil loss and desertification in Kenya: A Study in Marsabit District In: D.B. Thomas et al. (Eds), Soil and Water Conservation in Kenya. Department of Agricultural Engineering, University of Nairobi and Swedish International Development Authority (SIDA), Nairobi, Kenya.
- Aubry B. and Wahome E.K. 1983. Field Experiments on Soil Erosion in Amboseli, Kajiado District. A Paper Presented to the Second National workshop on Soil and Water Conservation in Kenya, Nairobi, March, 1982.
- Barber R.G. 1983. The Magnitude and Sources of Soil Erosion in Some Humid and Semi Arid Parts of Kenya and Significance of the Soil Tolerance Values in Soil Conservation in Kenya. In Thomas D.B. and Sega W.M. (Eds). Soil and Water Conservation in Kenya. Proceedings of a Second National Workshop 21–23 September, 1977. University of Nairobi: 20–46.
- Biamah E.K. 1986. Technical and Socio-Economic Considerations in Rehabilitating and Conserving an Eroded/Denuded Catchment

- area. A Case Study of the Chemoron Catchment Area in Central Baringo, Kenya. A Paper Presented to the Third National Workshop on Soil and Water conservation in Kenya, Kabete Campus, Nairobi.
- Black C.A. (ed.) 1965. Methods of soil analysis. Agron. Monogr. 9. Pt.2. ASA, Madison, WI.
- Castillo V.M., Martinez-Mena M., and Albaladejo J. 1997. Runoff and Soil Response to Vegetation Removal in a Semiarid Environment. Department of Soil and Water Conserv., CEBAS-CSIC, Murcia, Spain. *Soil Sci. Soc. Am. J.* 61:1116–1121.
- Chinene V.R.N. and Lungu D. 1990. Measuring Soil Loss in Different Land Use Systems on an Oxic Paleustalf in Lusitu, Zambia. *Trop. Agric. (Trinidad)* 67:221–222.
- Clark R. 1980. Erosion Condition Classification System. US Department of the Interior Bureau of Land Management. Denver Service Center, Denver, Colorado.
- Dunne T. 1974. Suspended Sediment Data for Rivers of Kenya. Report to the Ministry of Water Development.
- Dunne T. and Ongwenyi G.S. 1976. A New Estimate of Sedimentation Rates in the Upper Tana River, Kenyan Geographer, 2, pp. 20–38.
- Edwards K.A. 1979. Regional Contrasts in Rates of Soil Erosion and their Significance with Respect to Agricultural Development in Kenya. In Lal, R and Greenland D.J. (Eds). *Soil Physical and Crop Production in Willey and Sons, Chichester.*
- FAO 1985. Erosion induced loss in soil productivity. A Research Design. FAO Consultant's Working Paper No. 2, FAO, Rome.
- FAO-UNESCO 1974. *Soil Map of The World: Volume VI, Africa.* Unesco, Paris.
- Frye W.W., Ebelhar S.A., Murdock L.W., and Blevins R.L. 1982. Soil Erosion Effects on Properties and Productivity of two Kentucky soils. *Soil Sci. Soc. Am. J.* 46:1051–1055.
- Gachene C.K.K., Jarvis N.J., Linner H. and Mbuvi J.P. 1997a. Soil Erosion Effects on Soil Properties in a Highland area in Central Kenya. Joint Contribution from the Departments of Soil Science, University of Nairobi, Kenya; and Department of Soil Sciences, Swedish Univ. of Agric. Sciences, Uppsala, Sweden. *Soil Science Society. Am. J.* 61: 559–564.
- Gachene C.K.K., Mbuvi J.P., Jarvis N.J. and Linner H. 1997b. Maize Yield Reduction due to Erosion in a High Potential Area of Central Kenya Highlands. Joint Contribution from the Departments of Soil Science, University of Nairobi, Kenya; and Department of Soil Sciences, Swedish University of Agric. Sciences, Uppsala, Sweden. *African Crop Sci. Journal*, Vol 6. No. 1 pp. 29–37.
- Gicheru P.T., Gachene C.K.K. and Biamah E.K. 1998. Effects of Tillage and Mulching on Soil Moisture Conservation and Crop Production. Paper Published in the Applied Plant Sciences, 1998. Kenya Agr. Res Institute and University of Nairobi.
- Hinga G., Muchena F.N. and Njihia C.M. 1980. Physical and Chemical Methods of Soil Analysis. Report, National Agricultural research Laboratories, Nairobi, Kenya.
- Helming K., Romkens M.J.M. and Prasad S.N. 1998. Surface Roughness Related Process of Runoff and Soil Loss: A Flume Study. Center for Agricultural Landscape and Land Use Res., Dep. Of Soil Landscape Res, Munchenberg, Germany; USDA-ARS Nat. Sedimentation Lab., Oxford; Dep. Of Civil Eng., Univ. of Mississippi. *Soil. Sci. Soc. Am. J.*
- Lal R. 1988. Monitoring Soil Erosion Impact on Crop Productivity. In: Lal R. (ed.) *Soil Erosion Research Methods.* Soil and Water Conservation Society, Ankeny, IA.
- Larson W.E. and Pierce F.J. 1991. Conservation and Enhancement of Soil Quality. P.175–203. In International Workshop on Evaluation for Sustainable Land Management in the Developing World, Chiang Rai, Thailand. 15–21 Sept. Int. Board for Soil Res.
- Lewis L.A. 1985. Assessing Soil Loss in Kiambu and Muranga Geogr. Annaler, 67A: 273–284.
- Mehlich, A., A. Pinkerton, W. Robertson, and R. Kempton. 1962. Mass Analysis Methods for Fertility Evaluation. Internal Publication, Ministry of Agriculture, Nairobi, Kenya.
- Okoth P.F. 1998. A Hierarchical Land Use Classification System for Kiambu. FAO, Consultancy Report.
- Okoth P.F. and Omwega A.K. 1989. Nutrients Lost from a Nitisol with no Conservation Measures in Githunguri Division of Kiambu District, Kenya. Kenya Soil Survey and Geography Dept. Kenyatta University. Sixth, Int. Soil conserv. Conf. 6–18 Nov, 1989, Ethiopia and Kenya.
- Omwega A.K. 1989. Crop Cover, Rainfall Energy and Soil Erosion in Githunguri (Kiambu District), Kenya. A Thesis Submitted to the University of Manchester for the Degree of Doctor of Philosophy in the Faculty of Science.
- Ongwenyi G.S.O. 1978. Erosion and Sediment Transport in the Upper Tana Catchment with Special Reference to the Thiba Basin. PhD Thesis University of Nairobi, 1978.
- Pereira H.C. and Jones P.A. 1950. The Maintenance of Fertility in Dry Coffee Soils. *East Africa Agricultural Journal* 15: 174–79.
- Renard K.G. and Follet R.F. 1985. A Research Strategy for Assessing the Effect of Erosion on Future Soil Productivity in the US. P. 691–702. In: El-Swaify S.A. et al. (ed.) *Soil Erosion and conservation.* Soil conservation Society of America, Ankeny, IA.
- Salter P.J. and Good J.E. 1967. Crop Responses to Water and Different Stages of Growth. Commonwealth Agricultural Bureaux, Farnham Royal, Bucks, England.
- Sarrantonio M. and Scott T.W. 1988. Tillage Effects on Availability of Nitrogen to Corn following a Winter Green Manure Crop. *Soil Science Society. Am. J.* 52:1661–1668.
- Shitakha F.M. 1983. Detailed Soil Survey of the Coffee Research Station, Ruiru, Kiambu District.
- Sombroek W.G., Braun H.M.H. and Van der Pouw B.J.A. 1980. Exploratory Soil Map and Agroclimatic Zone Map of Kenya. K. S. S., Min of Agric, Nairobi. Report No. E1.
- Stocking M.A. 1988. Assessing Vegetative Cover and Management Effects. In: R. Lal (Ed). *Soil erosion Research Methods.* Soil and Water Conservation Society, Ankeny, Iowa, USA.
- Thomas D.B.; Edwards K.A.; Barber R.G. and Hogg I 1981. Runoff, Erosion and Conservation in a Representative Catchment of Machakos District, Kenya. In: Morgan, op.cit.
- Tiffen M., M. Mortimor, and F. Gichuki, 1994. More people, less erosion. *Environmental Recovery in Kenya.* Acts press, Nairobi, Kenya.
- Walkley A. and Black I.A. 1934. An Examination of the Degtjareff Method for Determining Soil Organic Matter and a Proposed Modification of the Chromic Acid Titration Method. *Soil Sci.* 37:29–38.
- Wiegiers E. 1995. Land Use and Erosion Risk in the Kiambu District. Msc-Thesis. Department of Agronomy and the Department of Land Survey and Remote Sensing, Wageningen Agricultural University, The Netherlands.
- Wrigley G. 1988. *Coffee.* Longman Scientific and Technical, New York, USA and Essex, England.

The Use of Erosion Proxies for the Spatial Assessment of Erosion in a Watershed and Modelling the Erosion Risk in a GIS

Okoth P.F.¹, Oketch P.A.² and Kimani P.K.²

¹ *Tropical Soil Biology and Fertility (TSBF) Institute of CIAT, c/o The World Agroforestry Centre (ICRAF), United Nations Avenue, P.O. Box 30677, Nairobi, Kenya, Telephone: 254-20-524775, Cell: 254-722-768537, Fax: 254-20-524764, Email: p.okoth@cgiar.org;* ² *Kenya Soil Survey, National Agricultural Research Laboratories, Kenya Agricultural Research Institute, P.O. Box 14733, Nairobi, Kenya, e-mail: kss@iconnect.co.ke*

Abstract

This paper presents a new approach to soil erosion risk assessment and modelling. The approach recognizes that erosion risk is linked to biophysical landscape features, societal activities and spatio-temporal attributes of the landscape processes. The assessment involves making measurements of soil erosion in the field and linking the erosion features to some selected landscape elements that act as either drivers or disruptors of erosion. These drivers or barriers of erosion are referred to in this paper as erosion proxies. Examples of the erosion proxies in a watershed include drainage ditches, field boundaries, footpaths, animal tracks and other man made elongate features that cause water concentration and flow in the watershed. These are referred to in this paper as erosion drivers. Barrier proxies or disruptors of erosion include: hedges, closed fences, grassed field boundaries, trashed field boundaries, banded field boundaries, barrier ditches, constructed dykes or built earth dams. Erosion risk is on the other hand defined as the potential for the occurrence of soil erosion due to the presence or absence of the proxies. The watershed has a high or low risk of erosion depending on the intensity of occurrence of erosion proxies. The approach views the watershed more from the principles of energy and matter flows in them rather than by assessing the individual factors in a deterministic erosion model such as the Universal Soil Loss Equation (USLE) (Wischmeier and Smith, 1978). The net risk of erosion in the watershed, or sub-watershed is modelled by summing up the total length of the erosion drivers and the total length of the disruptors in a GIS database. The ratio between the sum of the drivers, and the total sum of the drivers and the disruptors provides an indication of whether the watershed is at high or low risk.

The method uses the spatial characteristics of the erosion proxies to extract them from the broader landscape mosaic through visual interpretation of aerial photographs or satellite images. The results of the interpretations are afterwards digitized into a geographic information system (GIS) database and processed to paper maps. The produced maps are then carried to the field to characterize and link the proxies to the presence or absence of soil erosion features. In the field, the occurrence of different soil erosion features on each erosion proxy is measured and recorded.

The influence of the individual erosion proxy is obtained by using the analysis of variance (ANOVA) and the F test. The statistical analysis forms the basis for ranking erosion proxies into different risk categories and for selecting the best mitigation options.

The method is tested on an agricultural test area at the National Agricultural Research Laboratories (NARL) in Nairobi. The results indicate that grassed field boundaries (an example of an erosion proxy) form good management practice for conserving the NARL sub-watershed. Other proxies for use against the risk of erosion include constructed earth and stone bunds along the field boundaries, trash and stover cover along the field boundaries or any other method that disrupts water flow in channels on the watershed or sub-watershed. Due to this method of assessment, field plots and large portions of the test area at the National Agricultural Research Laboratories compound is now well conserved and suffers a minimum risk of soil erosion by water.

Key words: Erosion proxies, Spatial assessment, Spatial modelling, Water watershed, Soil water erosion, GIS, Environmental conservation

Introduction

Soil erosion by water manifests itself in any terrain in the form of sheet-wash, rills, gullies or landslides. These features have been used as field indicators for assessing and mapping soil erosion visually and through aerial photo interpretations (e.g. Bergsma, 1970, Morgan et al., 1997). Other methods for assessing soil erosion include sediment yields data (Ongwenyi, 1978; Edwards, 1979). Indirect methods include the use of the factors of erosion in a deterministic model such as the Universal Soil Loss Equation (USLE) by Wischmeier and Smith (1978) or the Revised Universal Soil Loss Equation by Renard et al. (1991).

Though the use of aerial photographs in the assessment of soil erosion has assisted in distinguishing land areas with visible soil erosion, they have however, not been able to show the extent of erosion that goes on below the plant canopy cover. This is mainly due to obscurity of below-canopy to above ground observations in remote sensing or aerial photography. The use of river sediment data has so far also not been able to trace the eroded material back to its original source. The data therefore, cannot be easily used in soil and water conservation where the affected areas need to be identified for attention and mitigation.

The development of mathematical models for estimating soil loss started with Zingg in 1940. He related soil loss to slope length and gradient. Smith (1941) included factors for the influence of crops and conservation practices to his soil loss model. The addition of the rainfall factor resulted in the Musgrave equation (Musgrave, 1947). Finally, data collection and analysis of 10,000 plot years from 49 locations led to the development of the 'Universal Soil Loss Equation (USLE) (Wischmeier and Smith in 1978), which is still the basic tool for soil conservation in the United States and many other countries. The equation is expressed as:

$$A = R * K * L * S * C * P \quad (1)$$

Where, soil loss (A) is the mean annual soil loss in tons/ha on a long-term basis. Rainfall erosivity (R) is calculated from rainfall charts for single erosive rains during a period of 22 years and represents the mean annual erosivity for the period. Soil erodibility (K) indicates a soil's susceptibility to the erosive forces and gives the amount of soil loss per unit erosivity. L, S, C and P are expressed as ratios of soil loss on a given unit plot.

The USLE was designed to predict annual soil loss from sheet and rill erosion on a field scale. The model is described as a lumped equation according to Foster (1988) and does not account for deposition nor does it predict sediment yield. The USLE estimates erosion for moderate slopes and medium soil textures. It may be inaccurate at extreme slopes and textures, and in regions where the erosive forces are primarily from overland flow (Robinson, 1979). Since its development, the USLE has been modified several times and other models such as the modified universal soil loss equation (MUSLE) and the revised soil loss equation (RUSLE) have also been developed from it.

(Williams, 1975; Foster and Meyer, 1975) developed the modified USLEs, commonly known as the MUSLEs while the RUSLE was developed by (Renard et al. 1991). In the MUSLE the R-factor of the USLE is adjusted by introducing a hydrological runoff factor besides the rainfall factor R. All other characteristics remain the same.

The RUSLE developed by Renard et al. (1991) include improvements such as an expanded erosivity or the iso-erodent map for the Western United States based on data analysis from more than 1,000 locations. Also included in the revision were minor changes in the R factor based on data collected in the Eastern United States, where flat slopes occur in regions of long, intensive rainstorms. Erodibility data from around the world were also reviewed and an equation developed that gives useful estimation of K as a function of the average diameter of the soil particles.

The factors used for predicting soil loss as presented in Equation 1, must be included in the model to estimate the expected soil loss. In the absence of data for any of the factors, estimating soil loss becomes difficult and inaccurate. Moreover, the values obtained from the model are mere estimates that vary according to the prevailing rainfall and slope conditions (Nill et al., 1996).

The modelling of erosion risk and soil loss is normally made complex by the enormity of data required to reasonably construct real-time terrain conditions and equally the soil erosion occurring on them (Nill et al., 1996). Micro-differences in the terrain are not normally easy to model, nor is it possible to easily predict natural factors such as rainfall, which in most cases are erratic, especially in the tropics (Stocking, 1987).

Another method for estimating soil loss and erosion is by the use of the Wischmeier plots. The Wischmeier plots are normally 22.1 m long and 1.87 m wide and

placed on a 9% slope. The weakness of the method is that estimating soil loss from run-off plots is usually site and time specific and the results cannot be conveniently extrapolated to cover other or wider geographic areas unless many data points and repetitions are included for validating the experiments (Stocking, 1987 in: Blaikie and Brookfield, 1987).

As an observation, individual deterministic-models or run-off plots might not provide all the answers in erosion risk prediction in the broad landscape. They however, present a reasonable indication of what goes on during an erosive rainstorm. Event-based process models are more appropriate compared to empirical models (Stocking, 1987; Foster et al., 1980). Issues of validity, accuracy and application context still need to be tackled in most of the models. By their very nature, soil erosion models only provide soil loss estimations, and therefore by extension will never be exact. It may sometimes be easier to work backwards first by observing the occurrence of soil erosion and then relating the observed erosion with the environments in which it occurs. This strategy was used in developing the methodology presented in this paper.

The method seeks to establish an alternative way by which erosion risk can be assessed. The strategy recognizes that erosion risk is linked to biophysical landscape features, societal activities and spatio-temporal attributes of the landscape processes. It deviates from other erosion risk assessment methods which assess soil erosion risk by measuring soil loss from runoff plots under different experimental conditions or from river sediment loads. It rather views the landscape as a medium in which erosion processes are taking place in an intricate manner at different spatial scales and which are sometimes not easy to discern. It targets landscape features which relate to or condition the occurrence of water erosion and which are also linked to rural land utilization hereby referred to as the erosion proxies. The erosion proxies are targeted due to the opportunity they offer in soil and water conservation and their spatial attributes which enables a spatial analyst to capture them from the landscape continuum using aerial photographs or satellite images. The word '*erosion proxy*' as used, is considered to be connotative of landscape features with some bearing on the conditioning or disrupting water erosion, while they are in themselves not the common features of erosion. Soil erosion features are most of the time occurring on or are absent from the erosion proxies. The method targets features which can be manipulated

for better control of soil erosion and for environmental conservation.

The aim of the study was to increase watershed or water watershed conservation through a spatially oriented erosion risk assessment method. The specific objectives were 1) to develop a spatial method for soil erosion risk assessment in a watershed, watershed or sub watershed, and, 2) to create an improved understanding of soil erosion and management in a watershed.

Materials and methods

General remarks about the method

The method identifies a *watershed* as a '*delimiter*' or a '*semi-whole*' unit of flowing water. Sub-watersheds being parts of a watershed are all included. From hierarchy theory, the watershed is considered to be a closed environment in which soil erosion is taking place without external interference depending on how the internal features of the watershed are arranged and constructed. A water-catchment in the normal definition refers to an elementary hydrographic surface where rainwater falls before it drains into the drainage network or river-flow stream (Martínez-Casasnovas and Stuver, 1998). A catchment thus could imply a single landscape unit or an aggregation of several units depending on scale. A watershed on the other hand includes both the catchment and the drainage channels within a single morphometric divide. The method stresses more on an analysis of the internal elongate flow features of the watershed and how they relate to the occurrence of soil erosion. The flow occurs in elongate channels that form the carriers of the eroded soil material. These channels are in this paper considered to be the drivers of erosion. For clarity, drivers of erosion are linear elongate features which favour and cause the concentration of water and flow during a storm and thereby causing soil erosion while disruptors of erosion are features that hinder or form barriers against the flowing water. These spatial drivers and disruptors of erosion are by definition referred to in this paper as erosion proxies.

Examples of drivers of erosion include drainage ditches, field boundaries, footpaths, animal tracks or any other linear features that concentrate and allow water to flow through them. Barrier hedges, closed fences, grassed field boundaries, trashed field boundaries, constructed dykes or built earth dams that are

used as barriers against erosion are also defined as erosion proxies but more as disruptors of erosion. Erosion risk is on the other hand defined as the potential for the occurrence of erosion due to the presence or absence of the erosion proxies.

The ratio between the sum of the proxy drivers of erosion and the total sum of the proxy disruptors of

erosion provide an indication of the total watershed erosion risk. When the driving erosion proxy total length is greater than the barrier length the watershed is considered to be at higher risk whereas greater barrier lengths are considered to lower the risk.

The method uses GIS to capture, store, analyse and model the features in a graphical manner for

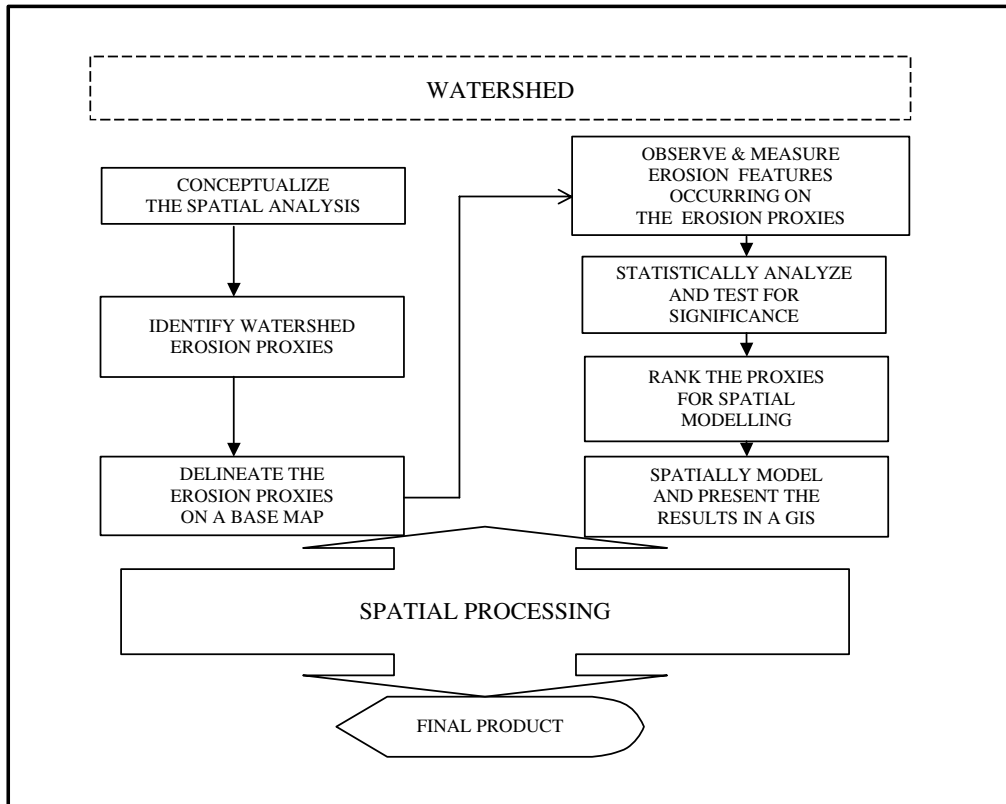

Figure 1. A flowchart of the methodology.

Table 1. Erosion proxies and observable erosion features used for the assessment and modelling of erosion risk in a watershed.

Erosion proxies in a watershed		Observable erosion features
Drivers of erosion in the watershed	Disruptors of erosion in the watershed	
<ul style="list-style-type: none"> - bare field boundaries - footpaths - animal tracks - drainage ditches 	<ul style="list-style-type: none"> - retention ditches - barrier hedges - closed fences - grassed field boundaries - trashed field boundaries - constructed dykes - built earthdams 	<ul style="list-style-type: none"> - soil movement - surface litter movement - root exposure - stem washing - flow patterns - rills - gullies

visual representation and for mathematical analysis and modelling. The geometric maps are linked to tables with data that provide the ratio of the modeled risk of the selected erosion proxies. The sequential implementation of the different parts of the method is shown in Figure 1. Table 1 shows the erosion proxies and observable erosion features in a watershed.

Execution steps of the methodology

The method involves the execution of eight steps where each step deals with different tasks. The steps in the methodology are shown in Figure 1. As an initial step the executor of the methodology is required to understand the kind of watershed, watershed or sub-watershed he or she is dealing with. It could be an agricultural or rangeland landscape. This step makes the executor be aware of the kinds of elongate features that he/she might encounter and the size of the watershed to be dealt with. He or she must determine how data on the landscape is captured and the type of GIS data models that are to be used. It is an organizational and mental step where the executor determines the tools he or she is going to use in the subsequent steps. It is referred to as the conceptual step of the methodology.

The second step involves the determination of the erosion proxies occurring on the watershed. Suitable data sources such as aerial photographs scale 1:20,000 or larger are identified and interpreted. The visible and discernible erosion proxies are each given a unique identifier for field characterization. After this, the photo

interpretation boundaries are transferred onto a base map at the same scale. In the absence of a base map, the photo interpretation boundaries are transferred to transparent paper sheets on which the watershed boundaries and the identified erosion proxies are mapped. After preparing a map of the watershed and the erosion proxies, the lines are digitized into a GIS database in the third step. For the linear elongate watershed features, an object oriented data model (Molenaar, 1989) is used in a vector-based GIS software. The resultant map is plotted on a GIS plotter ready for observations in the field.

The fourth step involves taking the GIS map to the field for characterization and observing visible erosion features occurring on the delineated erosion proxies. Erosion features in the field are described, measured and recorded according to a modified Clark's (1980) method of field erosion assessment. Table 2 shows the erosion features and their placement into severity classes. This is a modification of Clark's (1980) classification categories. A minimum of three observations are made and recorded for all the features of erosion present on a proxy and an average computed. All the data are entered on pre-designed forms where the unique identifier of the erosion proxy is entered in addition to other data on erosion and the terrain such as slope, aspect, etc.

The fifth step involves statistical analysis, which validates the link between the erosion features and the identified erosion proxies. The severity of erosion on the particular proxy is also tested at this stage. Whether the proxies differ in their level of containment of erosion is determined by using the analysis of variance in the sixth step.

Table 2. Erosion feature classification according to severity classes.

Erosion feature	Severity Class				
	Stable	Slight	Moderate	Critical	Severe
Soil movement	0–1.5 cm	1.5–3.0 cm	3.0–5.0 cm	5.0–8.0 cm	> 8.0 cm
Surface litter	0–2%	2–10%	10–25%	25–50%	> 50%
Root exposure	0–0.5 cm	0.5–2.0 cm	2.0–3.0 cm	3.0–5.0 cm	> 5.0 cm
Stem washing	0–1.0 cm	1.0–3.0 cm	3.0–5.0 cm	5.0–7.0 cm	> 7.0 cm
Flow pattern	0–2%	2–10%	10–25%	25–50%	> 50%
Rills:Depth	1–4 cm	4–8 cm	8–12 cm	12–20 cm	>20 cm
Width	< 10cm	10–25 cm	25–45 cm	45–80 cm	>80 cm
Frequency	10–5 m	5–4 m	4–3 m	3–2 m	< 2 m
Gullies:Depth	15–35 cm	35–55 cm	55–75 cm	75–95 cm	> 95
Width	30–60 cm	60–100 cm	100–150 cm	150–200 cm	
Frequency	> 500 m	500–150 m	150–50 m	50–15 m	15–5m

(A modification of Clark's 1980 classification system by Okoth et al. 1999).

The seventh step involves the weighting of the drivers and disruptors of erosion according to their degrees of influence. Their degrees of influence are obtained from Table 6. The eighth step and in the GIS database, the net erosion risk ratio is computed. First, the length of all the proxy drivers and disruptors are summed up each separately. This is followed by the computation of the overall erosion risk, which is computed as a percent ratio using the following equation.

$$Er = \frac{W_d}{W_d + W_b} \times 100 \quad (2)$$

Where:

Er = Erosion risk

W_d = Weighted length of the erosion drivers

W_b = Weighted length of the erosion disruptors or barriers

Testing the methodology

The method as described was tested at the National Agricultural Research Laboratories (NARL) in Nairobi after three heavy rainstorms in April 2000. The identified erosion proxies in the case of the NARL sub-watershed were field-plot boundaries, constructed non-grassed earth bunds, grassed earth bunds, grassed trenches, and non-grassed unbundled field boundaries. They were all found to bear a strong relationship with the occurrence of erosion.

The method was found to be quick and can easily be applied in any watershed. The tool of measurement is an ordinary portable tape measure and a slope metre. The pre-requisite for applying the method is a good knowledge for the recognition of erosion features.

Environment of the study area

The National Agricultural Research Laboratories (NARL) is located in the Nairobi Province of Kenya. The Centre co-ordinates of the compound are 36°41' East and 1°15' North of the Equator. The total acreage is about 35 ha inclusive of buildings, roads and experimental fields. This study focused on erosion conditions occurring within the experimental fields, which cover about 20 ha.

The area has an almost flat topography (0–2%), with the slope gradient gradually increasing towards the North and East to about 6% slope. Within the experimental fields, the topography is gently undulating with a general North to Northeast aspect. The ridge on which NARL is located is bordered to the South by a tributary of the upper Nairobi River, which flows in an easterly direction. To the North is a canalized stream following the same direction. Both streams contribute to the Athi River. The area is underlain by the Limuru Quartz Trachyte which are intermediate extrusive igneous rocks dating back to the early Pleistocene according to Saggerson (1971).

NARL has a bimodal rainfall pattern with one rainy season falling between mid-March to May and the other

Table 3. Climate data for the NARL station.

Month	Mean monthly rainfall (1931–1960)	Mean monthly rainfall (1923–1970)	Mean monthly potential evaporation	Mean monthly potential evapotranspiration	Mean monthly air temperature (maximum)	Mean monthly air temperature (minimum)	Mean monthly air temperature (mean)
January	44	52	173	115	25.3	12.4	18.9
February	54	46	176	117	26.5	12.8	19.7
March	100	106	183	122	25.9	13.7	19.9
April	205	223	146	97	24.2	14.3	19.4
May	156	168	125	83	22.9	13.3	18.1
June	47	42	113	75	21.9	11.8	16.9
July	18	15	108	72	21.0	10.8	15.9
August	25	27	116	77	21.6	11.0	16.3
September	24	22	140	93	23.9	11.5	17.7
October	52	54	158	105	24.8	12.7	18.8
November	108	133	141	94	23.3	13.4	18.4
December	77	85	159	106	23.6	13.0	18.3
Annual	881	926	1,738	1,156	24	13	18

falling between mid-October to December. According to Siderius (1976), important characteristics of the climate are the alternating dry and wet seasons and the absence of large seasonal changes in temperatures. The period from June to October is cool rather cloudy, and almost dry, while the warmest time of the year is encountered from mid-December to mid-March. The climatic data of the area is shown in Table 3.

The soils according to Siderius (1976), classify as Clayey, kaolinitic, non-calcareous, acid, isothermic, very deep Paleustult in the USDA (1975) classification. The FAO Soil Legend of the World (1997) distinguishes them as Humic Nitisols. These are soils with an argic B-horizon, with clay distribution, which does not show a relative decrease from its maximum of more than 20% within 150 cm of the surface. They show gradual to diffuse horizon boundaries between A and B-horizons and having *nitic properties* in some sub-horizons within 125 cm of the surface. The NARL Nitisols are humic with an umbric A-horizon and a base saturation (by NH₄OAc method) of less than 50% in parts of the B-horizon within 125 cm of the surface.

Results and discussions

Influence of the erosion proxies

Table 4 shows the results of the measurements of the features of erosion in each boundary category (erosion proxy) at NARL. The erosion proxies as described earlier are elongate constructed or natural features occurring on watersheds, or sub-watersheds and which have an influence on the occurrence of erosion but are in themselves not erosion features. Field boundary management methods of different field plots are all considered to be erosion proxies since they induce water concentration and flow during a rainstorm. In NARL field boundaries with grass cover and stone bunds were eight, boundaries that had bunds but with no grass cover were five, boundaries trashed with maize stover were three and boundaries with 100% grass cover were only two. The field boundaries that lacked grass cover and bunds were placed in two categories. Field boundaries that were on slopes whose steepness were less than 2% and field boundaries occurring on slopes with their steepness greater than 2%. Table 4 shows that the highest occurrence of erosion, was in field boundaries that had neither grass cover nor earth bunds and occurring on slopes steeper than 2%. It was observed that on the field boundaries with slopes equal to or

less than 2% there were depositions even when there were no bunds. Under similar boundary conditions and with slopes steeper than 2%, rills instead of depositions occurred. On the grassed field boundaries there were neither depositions nor formation of rills for varying slopes.

Though the computed averages (Table 4) showed a difference in the depth of the erosion rills occurring on the different erosion proxies, it was important to test the results statistically to determine the significance of the differences. Differences would indicate that some proxies are more important than others as drivers or disruptors of erosion in a watershed. A parametric one-way analysis of variance (ANOVA) was carried out to determine and obtain the variances between the different erosion proxies and variances within them. The ANOVA results are shown in Table 5b.

Table 5a shows the analysis of variance for the NARL erosion proxies. The ANOVA table (Table 5b) shows that the mean values of the treatments (erosion proxies) are different and are comparable to those in Table 4.

The obtained variance between the proxies is 413.94 and within the individual proxies is 35.71. Since the variance between the proxies is greater than the variance within the proxies, it is concluded that there is a higher variation between the different erosion proxies (field boundary categories) than the variations within each category of proxy. This means that different proxies influence the occurrence of erosion differently a factor that can be used to select the proxies that are the best disruptors of erosion. This was confirmed by the statistical F-test.

The F test and the degrees of freedom were used to determine the statistical significance of the observed differences (Table 5b). The calculated F value from the data of the proxies was 11.59 and those occurring in the statistical students F-test tables of significance were 2.48 at 5% significance and 3.58 at 1% significance. Since the calculated value was higher than the two values for significance from statistical tables the null hypothesis that there is no difference between the proxies was rejected and the inverse accepted that there is a difference between the occurrences of erosion on the different proxies with a 1% probability of error.

From Table 4, the highest rates of erosion occurred in the field boundaries with no grass cover and where there were no earth bunds. Besides lack of management measures along boundary furrows, boundaries with steeper gradients induced the formation of rills. Thicker erosion deposition features occurred on barriers along furrow boundaries where the slopes were

Table 4. Results of the measurements of the features of erosion in each boundary category at NARL.

Cases	Depth of rills on different erosion proxies at NARL measured in centimeters					
	Bunded and grassed boundaries*	Bunded and un-grassed boundaries*	Un-bunded and un-grassed boundaries* (slopes <2%)	Un-bunded and un-grassed boundaries** (slopes 3-6%)	Boundaries trashed with maize stover*	Only grassed boundaries
1	2	0	25	20	2	0
2	5	15	2	10	5	0
3	5	0	2	20	3	—
4	10	0	6	30	—	—
5	4	15	3	25	—	—
6	10	—	2	20	—	—
7	10	—	9	18	—	—
8	0	—	5	22	—	—
9	—	—	—	25	—	—
10	—	—	—	27	—	—
11	—	—	—	22	—	—
12	—	—	—	20	—	—
13	—	—	—	20	—	—
14	—	—	—	20	—	—
15	—	—	—	10	—	—
16	—	—	—	12	—	—
17	—	—	—	14	—	—
18	—	—	—	10	—	—
Average	5.75	6.00	6.75	19.17	3.33	0.00

- = Erosion proxies absent; ** = Observed erosion is in the form of rills; * = Observed erosion is in the form of soil depositions.

less than 2% while deeper rills occurred in furrow boundaries that had no barriers on them. Grassed field boundaries yielded no visible erosion features. The grassed field boundaries proved to be the best-bet disruptors of soil erosion with a mean value of 0.0 for the measured features of erosion. The trashed field boundaries yielded smaller depositions than the bunded boundaries whether with grass or without grass cover. Table 6 shows the average values of the erosion influenced by the different erosion proxies according to the measured features of erosion on them. The observed

differences are the basis for placing the erosion proxies in different classes for use in spatial erosion risk modelling or conservation.

Weighting and modelling the results

The weighting of the observed measured erosion features on the delineated proxies is carried out to determine the influence of each proxy on the occurrence or disruption of erosion. The computation is based on the

Table 5a. The analysis of variance for the NARL erosion proxies.

Variable	Mean	Sample Size	Group Standard Deviation
Bunded and grassed	5.9	8	3.7
Bunded and ungrassed	6.6	5	7.7
Grassed	0.0	2	0.0
Trashed	3.3	3	1.5
Unbunded and ungrassed < 2% slopes	6.8	8	7.8
Unbunded and ungrassed > 2% slopes	19.2	18	5.9
Total	11.1	44	5.9

Table 5b. One Way Analysis of Variance.

Source	DF	SS	MS	F	P
Between	5	2069.7	413.9	11.59	0.0000
Within	38	1356.7	35.7		
Total	43	3426.4	449.6		

Table 6. Ranking the boundary conditions (erosion proxies) according to erosion risk (-ve values mean low risk while +ve values mean high risk).

Erosion assessment proxy(Field boundary condition)	Mean values of erosion(cm)	Individual contribution To erosion	Weighted value for each proxy	Risk rating
Drivers of erosion (evidenced by the presence of rills)				
● Unbunded Ungrassed (slopes >2%)	19.1	19.2	+1.0	Very high
● Grassed	0.0	22.6	-1.0	Very low
● Trashed	3.3	19.2	-0.8	Low
● Bunded Grassed	5.9	16.7	-0.7	Moderately low
● Bunded & ungrassed	6.6	15.9	-0.7	Moderately low
● Un-bunded & un-grassed (slopes <2%)	6.8	15.8	-0.7	Moderately low

classification of the proxies as either disrupters (*Pb*) or drivers of erosion (*Pd*). First, a sum of the individual mean erosion rates on each proxy is computed. This is followed by the computation of the individual contribution of each proxy to the disruption or enhancement of erosion. Equations 3 and 4 expound on the weighting principle. As an illustration, there could be *n* number of individual erosion proxies in the whole population of erosion proxies in a watershed. If each proxy is designated as *i*, the weight allocated to each proxy may be computed by:

$$Wd = \frac{\sum_{i=1}^n Pd - Pd_k}{\sum_{i=1}^n Pd} \tag{3}$$

Where:

- Wd* = weighted value of individual erosion driving proxy
- Pd_k* = mean value of the individual erosion driving proxy
- Pd* = all driving erosion proxies

For the erosion driving proxies and;

$$Wb = \frac{\sum_{i=1}^n Pb - Pb_k}{\sum_{i=1}^n Pb} \tag{4}$$

Where:

- Wb* = weighted value of individual erosion disrupting proxy
- Pb_k* = mean value of individual erosion disrupting proxy
- Pb* = all disrupting erosion proxies

for the erosion distributing or barrier proxies.

Equations (3) and (4) are used to place a weighted value to the measured erosion-feature means of each delineated proxy. The weighted value provides an indication of the contribution of each proxy to the overall disruption or enhancement of erosion. The computed weighted value of each proxy (Table 6) is multiplied with the total length of that particular proxy (Table 7) using the GIS database to obtain the contribution of each proxy to the overall erosion risk. All individual values of the driver proxies are summed up like

Table 7. Weighted lengths of the individual erosion proxies.

Erosion proxy	Name of proxy	Weighted length
Drivers of erosion	Unbunded Ungrassed (Slopes >2%)	1171.7
Total weighted length		1171.7
Disruptors of erosion	Grassed field boundaries	4345.1
	Trashed field boundaries	84.9
	Bunded Grassed	73.0
	Bunded Ungrassed field boundaries	175.8
	Unbunded Ungrassed (slopes < 2%)	984.2
Total weighted length		5662.9
Erosion risk ratio (%)		17%

in the case of the disrupting proxies. A ratio of the watershed erosion risk, watershed or sub-watershed is then obtained by dividing the summed value of the driver proxies with a summation of total driver and total disruptor proxies as shown in equation (2).

In the NARL example, the results show that on slopes steeper than 2% rills deeper than 30 cm were formed on field boundaries with neither bunds nor grass cover. In such circumstances, where the flowing water met uneven ground inside the furrows, the

ORIGINAL MAP OF NARL

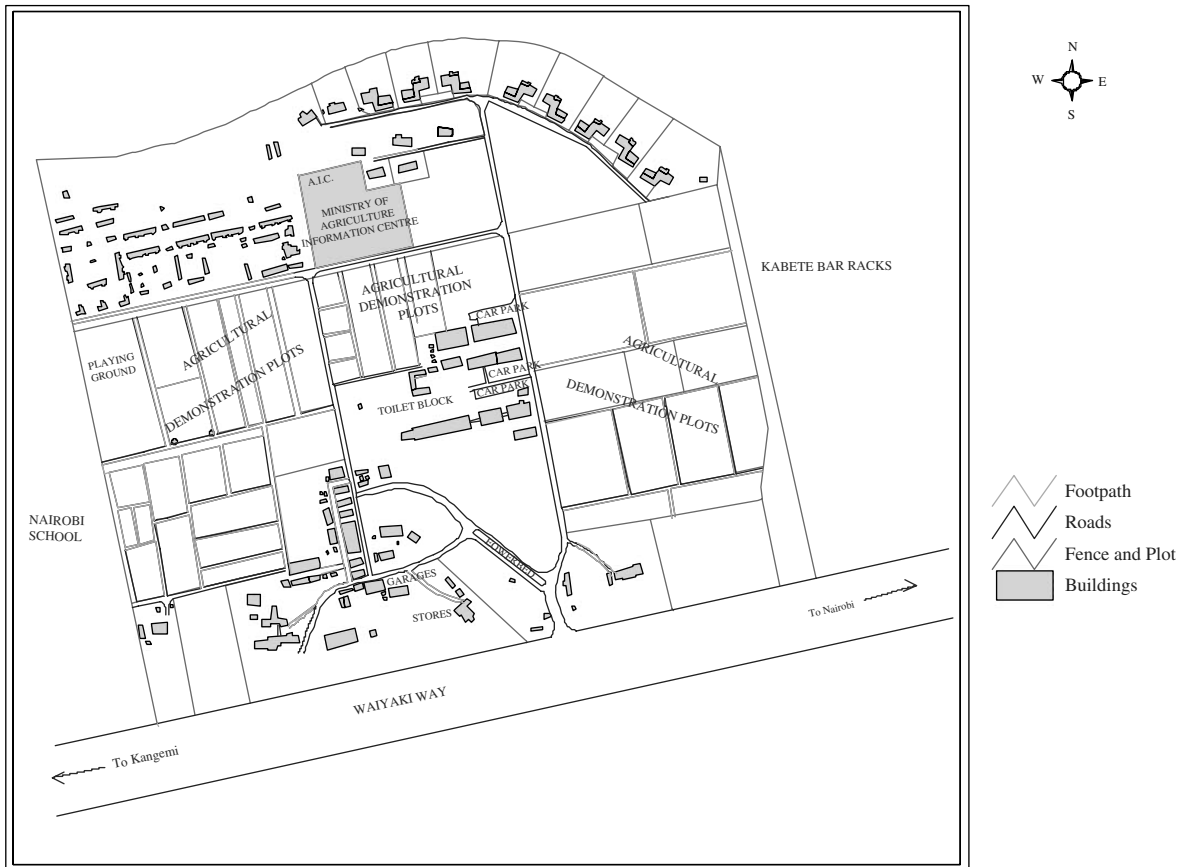

Figure 2. The original layout of the NARL Compound.

flow-channels cut through the raised land and across the crop fields. On the lower parts of such fields, rills became as wide as 62 cm, and gradually develop into gullies when not disrupted. Huge depositions occurred on the field-plot portions where the slope steepness was reduced to less than 2%. Figure 2 shows the original layout of the NARL compound where little conservation efforts had been made. Figure 3 shows current field layout with the different plot-boundary management practices (proxies) in NARL. In order to increase the NARL sub-catchment conservation, it is recommended that bunds across the slopes and cut off drains be constructed inside the field plots to complement the boundary bunds and grassed boundaries especially where slopes exceed 2%.

Table 6 shows the weighted values of the individual erosion proxies computed from the mean values of the rill-depths or deposition heights occurring on them. Field-plot furrow-boundaries that had no bunds and without grass cover on slopes steeper than 2% had the highest measured features of erosion (mean rill-depth of 19.17 cm). These were also the only erosion drivers (*driving proxies*) encountered in the NARL sub-watershed. The un-bunded and un-grassed field-plot

boundaries on slopes less than 2% had the highest depositions with a mean deposition height of 6.7 cm followed by the bunded and un-grassed boundaries on less than 2% slopes with mean deposition of 6.6 cm. Bunded and grassed field boundaries had depositions with a mean height of 5.88 cm and trashed boundaries a mean deposition height of 3.33 cm. It is only the fully grassed boundaries that showed no evidence of depositions. All the boundaries with depositions are considered to be the best choices for disrupting soil erosion and hence suitable for to be used for soil conservation along the field boundaries.

Table 7 shows the results of summing up the erosion drivers and disruptors for purposes of computing the sub-watershed erosion risk. All the drivers and disruptors are shown in Figure 3. Figure 2 shows the original layout of the NARL compound without the categorization of the erosion proxies. From the Table 7, the total weighted length of the erosion drivers was 1,172 metres while the weighted length of the disruptors was 5,663 metres. Using the same values in equation 2, a percent net risk of the sub-watershed is computed and the obtained value is 17%. This implies that 17% of the plot boundaries are at the risk of soil erosion and

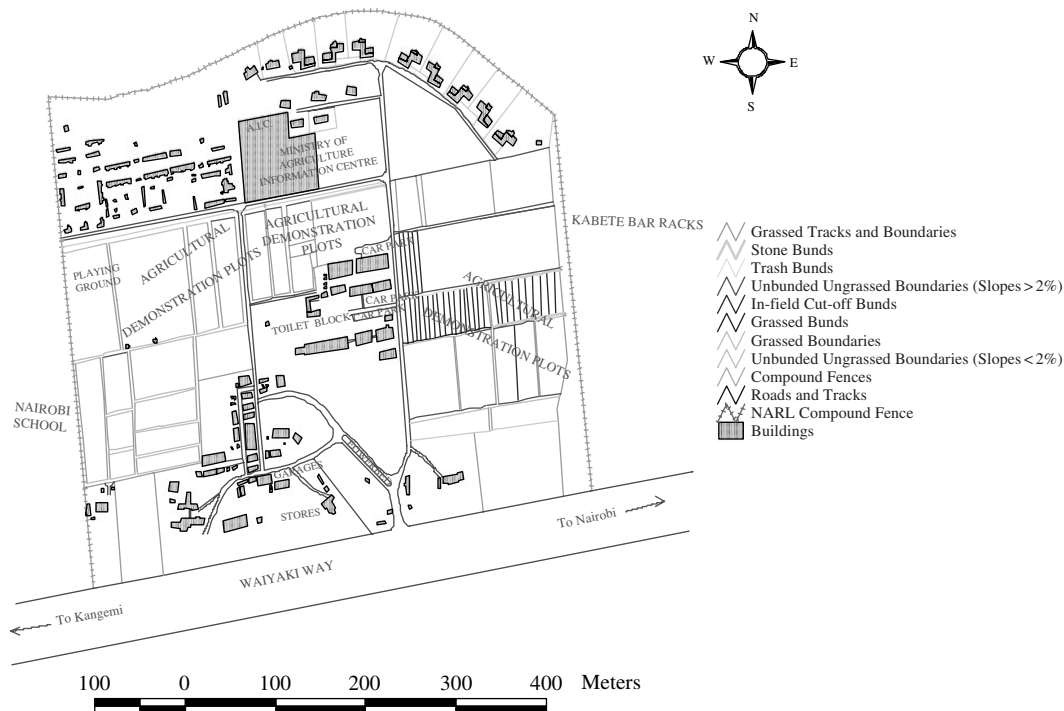

Figure 3. NARL Compound in April 1999 showing the layout of the different erosion proxies and where erosion risk exists.

must be properly managed by either planting grass or by constructing bunds and other forms of water barriers along the field-plot boundaries or furrows in order to manage the sub-watershed erosion risk.

Conclusions

The method as presented in this paper can be adopted, applied and tested in any watershed or watershed other than the NARL sub-watershed where linear spatial erosion proxies exist. Other linear proxies of erosion in a watershed or watershed include footpaths, hedges, fences, woodlot boundaries and tracks. More erosion indicators can also be discovered in the process of working and included in the risk computation model.

The method was easy to apply in the NARL sub-watershed in a spatial modelling scenario. The method needs further validating in other watersheds or sub-watersheds before being extrapolated. This could be considered to be a first approach to the procedures in the methodology. The tool of measurement was an ordinary portable tape measure and a slope metre. The pre-requisite for applying the method is a good knowledge for the recognition of erosion features and knowledge of GIG methods. Once the erosion proxies have been linked statistically to the occurrence of erosion, and some significance of such relationships established to be reliable, aerial photographs or satellite images can give a good indication of the erosion risk in a watershed if all the disrupting or barrier erosion proxies are delineated and mapped in a GIS. These could then be compared to the proxy erosion drivers. The requirement is that the photo interpreter should have good knowledge of recognizing the erosion proxies from experience or from their spatial properties. It should be clear that erosion proxies as used in this paper are in themselves not features of erosion as those shown in Table 2, they are elongate or linear features in the terrain that either disrupt or condition run-off concentration and flow and thus the occurrence of soil erosion. The erosion risk is calculated quantitatively in a ratio scale meaning that the results obtained in different watersheds or watersheds can be objectively compared.

A watershed or water watershed can be well conserved if the best disruptors of erosion are identified and placed on the pathways of the erosion drivers. In an agricultural environment, soil and water conservation measures inside individual field-plots, reinforce the watershed conservation by minimizing soil and water

flows from the plots to the field boundaries where most watershed or water watershed erosion starts and continues through the interconnectedness of the boundaries, or channel flows by drainage ditches or footpaths.

Terrains with slopes less than 2% suffer lower risks of erosion and should therefore not incur a lot of energy and labour costs in conservation.

The method might be weak for the assessment of watershed erosion in non-agricultural land, but the determinant principle is that for any watershed, elongate linear water flow channels should be identified that cuts across vegetation barriers. The extent and interconnectedness of the erosion proxies and their coverage of a watershed must be assessed and related to measured erosion. The reliability of the model can be achieved by collecting river sediment loads from the studied watershed, and modeling soil loss for the same watershed assuming that it is bare. If the ratio of the river sediment load and the modeled soil loss are comparable or are close, then the method can be concluded to provide a good and reliable estimation of the erosion risk of the watershed.

References

- Bergsma E. 1970. Aerial photo-interpretation for soil erosion and conservation surveys. Part I: Soil Erosion features. ITC Lecture Notes SOL 13 Revision April 1980.
- Clark R. 1980. Revision condition classification system. US Department of the Interior Bureau of Land Management. Denver Service Center, Denver, Colorado.
- Edwards K.A. 1979. Regio-I contrasts in rates of Soil erosion and their significance with respect to agricultural development in Kenya. In: Lal, R and Greenland, D.J. (eds). Soil physical and crop production in the Willey and Sons, Cluchester.
- FAO-UNESCO 1997. Soil map of the world. Revised Legends with corrections and updates. Reprint of World soil Resources Report 60. Food and Agriculture Organization of the United Nations, Rome, 1988. Reprinted with corrections 1990.
- Foster G.R. and Meyer L.D. 1975. Mathematical Simulation of upland erosion by fundamental erosion mechanics. In ANONYMOUS (1977), 190–207.
- Foster G.R., Jane L.J., Nowlin J.D., Lafen J.M. and Young R.A. 1980. A model to estimate sediment yield from field-size areas: Development of a model. International Institute of applied systems analysis, A-2361 Laxenburg, Austria. P40.
- Foster G.R. 1988. Modelling soil erosion and sediment yield. In Soil Erosion Research Methods LalR. (ed) Published by Soil and Water Conservation Society, Ankeny, Iowa, USA.
- Martínez-Casasnovas J.A. and Stuiver H.J. 1998. Automated delineation of drainage networks and elementary watersheds from digital elevation models. ITC Journal, Volume 3/4 pp 198–208.
- Molenaar M. 1989. Single valued vector maps. A concept in GIS. Geo-information Systems, 2(1), pp. 18–26.

- Morgan R.P.C., Rickson R.J., McIntyne K., Brewer T.T. and Altshul H. J. 1997. Soil erosion survey of the central part of the Swaziland. *Soil Technology* Jur-1 11: 263–289.
- Musgrave G.W. 1947. The quantitative evaluation of factors in water erosion, a first approximation. *J. Soil Water Cons.* 2, 3: 133-138.
- Nill D., Schwertmann U., Sabel-Koschella U., Ber-rd M. and Brewer J. 1996. Soil erosion by water in Africa. Principles, predication and Protection. GTZ GmbH Number, 257. 292pp.
- Okoth et al. 1999. Consequences of field management and soil erosion on the sustainability of large-scale coffee farming in Kiambu. *Soil Science Society of East Africa Proceedings, Uganda. 17th Conference*, pp. 331–339.
- Ongwenyi G.S.O 1978. Erosion and sediment transport in the upper Ta- watershed with special reference to the Thiba Basin. Ph.D. thesis, University of Nairobi, 1978.
- Renard K.G., Foster G.R., Weesies G.A. and Porter J.P. 1991. RUSLE, Revised Universal soil Loss Equation. *Jour-l of soil and water conservation*, 41(1): 30–33.
- Robinson A.R. 1979. Sediment yield as a function of upstream erosion. In: Peterson A.E. and Swan J.B. (ed.). *Universal soil loss equation: Past, present and future*. SSSA special publication no. 8, Soil Science Society of America, Madison Wisconsin. 53 p.
- Saggerson E.P. 1971. Geological map of the Nairobi area. (To accompany Geological Report No. 98). Geological survey of Kenya.
- Siderius W. 1976. Environment and the characteristics of the Nitisols at (Kabete, Nairobi). *Miscellaneous Soil Paper No. 10*. Ministry of Agriculture – National Agricultural Laboratories-Kenya Soil Survey.
- Smith D.D. 1941. Interpretation of soil conservation data for field use. *Agr. Eng.*, 22: 173–175.
- Stocking M. 1987. Measuring land degradation. In: Blaikie P. and Brookfield H. (Eds). *Land degradation and society*. Published by Methuen & Company Ltd., London.
- USDA –Soil Conservation Service 1975. *Soil Taxonomy. A system for soil classification*. Soil survey staff. United States Department of Agriculture. SMSS Technical Monograph No. 19.
- Williams J.R. 1975. Sediment Routing for small scale agricultural watersheds. *Water Research Bulletin* 11 (5).
- Wischmeier W.H. and Smith D.D. 1978. Predicting rainfall erosion losses. *Agricultural handbook no 537, USDA-science and education administration*, pp.58.
- Zingg A.W. 1940. Degree and length of land slope as it affects soil loss in runoff. *Agric. Eng.*, 21, 2: 59–64.

Bean Improvement for Low Soil Fertility Adaptation in Eastern and Central Africa

Lunze L.¹, Kimani P.M.², Ngatoluwa R.³, Rabary B.⁴, Rachier G.O.⁵, Ugen M.M.⁶, Vicky Ruganza⁷, Awad elkarim E.E.⁸

¹INERA, Centre de Recherche de Mulungu, B.P. 496 Bukavu, R.D. Congo (or INERA-Mulungu, B.P. 327 Cyangugu, Rwanda); ²Department of Crop Science, University of Nairobi, P.O. Box 29053 Nairobi, Kenya; ³Selian Agricultural Research Institute, P.O. Box 6024 Arusha, Tanzania; ⁴FOFIFA, B.P. 230 Antsirabe 110, Madagascar; ⁵KARI, P.O. Box 169 Kakamega, Kenya; ⁶NAARI, P.O. Box 7084 Kampala, Uganda; ⁷ISAR-Rubona, B.P. 138 Butare, Rwanda; Hudeiba Station, Sudan, Corresponding author: Lunze L.: <mailto:llunze@yahoo.fr>

Abstract

Low soil fertility is one of the most important common bean (*Phaseolus vulgaris* L) productivity yield limiting factors in Eastern and Central Africa and cause substantial production losses. As a component of integrated soil fertility management strategy, a collaborative research was initiated to screen bean germplasms for their tolerance to the important edaphic stresses of the region, namely soil acidity, low available phosphorus and low nitrogen. A set of 300 breeding lines of major market classes seed types were evaluated at varying ecologies under moderate and non-stress conditions at different locations in five countries. Bean genotypes evaluated vary considerably in their yield under stress conditions. Several lines identified tolerant to individual stresses and gave yield advantage over previously selected tolerant varieties. A few lines, BZ 12894-C-1, AND 932-A-1, DRK 137-1, Nm 12806-2A were tolerant to all three stresses, while ARA 8-B-1, AFR 709-1, AFR 703-1 and AND 1055-1 are tolerant to low P and low pH, and RWK 10, ARA 8-5-1, and T 842-6F11-6A-1 tolerant to low N and low pH. It is concluded that bean genotypes with multiple tolerance to edaphic stresses will make it possible to improve bean yield on low fertility soils common on small scale farmers' fields generally characterized by a complex constraints rather than a single stress.

Key words: common bean, edaphic stresses, low soil fertility, market classes, tolerance

Introduction

Common bean (*Phaseolus vulgaris* L.) crop production is very much constrained by low soil fertility in African countries. In Central and Eastern the major soil fertility related problems are found to be low available N and P, low exchangeable bases and soil acidity. According to the Atlas of common bean production in Africa (Wortmann et al., 1998), phosphorus is deficient in 65 to 80% of soils and nitrogen in 60% of soils in bean production areas of Eastern and Southern Africa, while about 20% of soils are acidic with a pH less than 5.0, containing

high levels of either aluminum or manganese. In the Great Lakes region of Central Africa, which comprises Burundi, DRC and Rwanda, where bean is an important food crop, 45% of the agricultural lands are acidic and the aluminum saturation above 60% in most soils of the highlands (Rutunga, 1997). Bean production losses in Sub-Saharan Africa due to abiotic stresses, namely N and P deficiency, soil acidity and water deficit are estimated at 1.3 million tons per year (Kimani et al., 2001).

Several soil management technologies for higher productivity have been developed, tested with farmers and widely promoted in the region (Esilaba et al.,

2001). Although soil amendment is the most effective and convenient way to improve the productivity, the vast majority of small-scale farmers bean producers cannot afford to correct soil acidity and nutritional deficiencies through conventional practices such as liming and application of mineral fertilizers. In the Great Lakes region for example, Dreschsel et al. (1996) report extremely low use of mineral fertilizer equivalent to 0.4 kg ha⁻¹. The only common practice used by farmers to improve soil fertility remains organic manure application. Therefore, the overall bean productivity remains generally low as substantial increase in productivity using the organic manure alone is limited because of insufficient quantities and the poor qualities of the available organic resources on farms (Palm et al., 1997; Ngongo and Lunze, 2000).

The genetic variability of common bean with respect to edaphic stresses is well established and has been well documented (Singh, 2001; Singh et al., 2003; Wortmann et al., 1995). Based on that, the identification and use of genotypes adapted to soils with inadequate nutrient supply and low pH associated nutritional disorders is now considered as a component of integrated soil fertility management approach to improving bean productivity in the region. Bean Improvement for low fertility soils in Africa (BILFA) was initiated with the objective of identifying bean genotypes adapted to low soil as a group work conducted by several scientists in different ecologies of bean production in Easter and Central Africa. The contributing countries are Kenya, Democratic Republic of Congo, Madagascar, Rwanda, Sudan, Tanzania and Uganda.

In the previous work, Wortmann et al. (1995) have reported considerable genetic variability in bean germplasm at the national and CIAT breeding pro-

grams with respect to low soil fertility tolerance. In this study, most bean lines identified as tolerant were small seeded and black, not often of regionally preferred seed types. As a consequence, very few lines were accepted by farmers. In Eastern Congo, for example, only two varieties, Mwamafutala (RWR 382) and Mwasole (Ubusosera) were widely adopted by farmers in Eastern Congo (Njingulula, 2003). Therefore, the later screening focused on major market classes seed type in the region.

The objective of the study is to provide small-scale farmers with common bean genotypes with tolerance to soil related constraints to allow for increased productivity on low fertility soils and household income. The present paper presents the results of evaluation of different market classes of common bean for tolerance to low soil nitrogen, available phosphorus and soil acidity.

Materials and methods

Evaluation sites

The evaluation was done at several sites in the participating countries with varying soil characteristics and ecologies. The experimental site for soil acidity and aluminum tolerance study were Gokongoro in Rwanda, Mulungu in Democratic Republic of Congo (DRC) and Antsirabe in Madagascar. The low phosphorus site was at Kakamega in Kenya. The low N site was Mulungu in DRC and Selian in Tanzania. The soil characteristics of the sites are presented in Table 1.

Table 1. Soil characteristics at the experimental sites.

Properties	Site					
	Mulungu 1	Antsirabe	Gikongoro	Kakamega	Mulungu 2	Selian
pH H ₂ O	4.7	4.6	4.8	4.9	5.8	6.50
Organic C (%)	2.3	3.7	5.0	2.6	2.4	1.80
Bray-I P (mg kg ⁻¹)	0.5	1.2	2.2	7.3 ⁽¹⁾	9.6	18.2
Exch. Ca (cmol(+) kg ⁻¹)	2.6	0.46	1.4	1.6	4.4	9.1
Exch. Mg (cmol(+) kg ⁻¹)	1.1	0.65	0.3	n.a	3.1	1.6
Exch. K (cmol(+) kg ⁻¹)	0.07	0.28	0.01	0.23	0.56	6.2
Exch. Al (cmol(+) kg ⁻¹)	2.6	2.43	2.6	–	–	–
Al saturation (%)	41	58	60	–	–	–

n.a.: not available; ⁽¹⁾ Olsen P, Mulungu 1: low pH site, Mulungu 2: low N site.

Materials origin and characteristics

The genotypes selected for evaluation to edaphic stresses tolerance consisted of an original set 300 breeding lines from the CIAT Africa regional breeding program at the University of Nairobi, Kabete Campus. These materials are the advanced lines generated from previously selected tolerant BILFA materials as breeding parents Lunze et al., 2002. They are distributed as follows in five most popular market classes in Eastern and Central Africa: 115 red kidney, 100 red mottled, 32 small red, 43 white navy and 19 pintos. Two check varieties were commonly used: a local released and popular varieties and a tolerant variety at each site: GLP 585 (Red haricot) at Kakamega, RAB 478 and 714 Acc at Gikongoro; Kirundo, Mwasole and Mwamafutala at Mulungu, and Goiano Precoce and Soafianarana at Antsirabe and Selian 97 at Selian.

Screening methodology

Screening methodology for bean tolerance to low soil fertility has been described (Wortmann et al., 1995). When screening for tolerance to low soil fertility, the objective is to detect the real difference in response to the stress to which the materials are exposed, and make selection according to their performance. The major problem encountered to achieve this is to select or create appropriate stress levels. It has to be high enough to produce a marked growth reduction, but not too high to completely inhibit the growth of the tolerant varieties. Screening is done under field conditions, and the main selection criterion is the grain yield.

Screening is done at two stress levels: moderate stress and no stress. The moderate stress corresponds to the stress level at which a well-adapted control variety under stress performs at 40 to 50% of its normal unstressed performance. All test materials are evaluated under a single stress only. All other constraints are carefully controlled. Bean root rot and bean stem maggot are prevented by spraying with locally available fungicides and insecticides.

At low nitrogen sites, Mulungu and Selian, nitrogen was applied at the rate of 0 and 30 kg ha⁻¹ on stress and non stress plots respectively. No other nutrients were added. At low P site Kakamega, phosphorus fertilizer was applied at the rates of 0 and 30 kg ha⁻¹. All plot received nitrogen applied in form of Calcium Ammonium nitrate (26%) in two split application at the rate of 30 kg ha⁻¹ N.

Three locations, Mulungu, Gikongoro and Antsirabe were high aluminium sites. Lime was applied at the rates of 0.5 ton ha⁻¹ on moderate stress plots and 2 tons ha⁻¹ on non-stress plots. At Gikongoro, however the lime rate on the non-stress plots was slightly increased to 2.5 t ha⁻¹ lime. A uniform rate of 5 ton/ha farmyard manure and 25 kg ha⁻¹ N, P and K were applied at both lime levels.

The set of 300 materials were evaluated for two seasons under moderate stresses at each location. Based on grain yield one third (100) best lines were then selected and evaluated further for two seasons at both moderate stress and no stress level. At this stage, 30 to 36 best lines are selected for each constraint. The present paper presents the results of the evaluation of these 36 lines.

The experimental layout used was a split plot with either lime, phosphorus or nitrogen levels as main plots and bean varieties as sub-plot, with three replicates.

Results and discussion

Low nitrogen

The yield data of the test bean genotypes at two nitrogen levels (0 and 30 kg N/ha) at Mulungu site are presented in Table 2. The genotypes varied significantly in their grain yield under nitrogen deficient conditions and in their response to applied N. Without applied nitrogen, the yield varied from 695 to 1789 kg.ha⁻¹ while with added nitrogen, the grain yield varied from 1258 to 3139 kg ha⁻¹ at Mulungu. Without nitrogen, most lines gave significantly higher yield than the local sensitive check Kirundo, and previously selected tolerant variety MwaMafutala. These lines considered to be adapted to low N conditions are Nm 12806-2A, AND 932-A-1, RWK 10, BZ 12894-B-1, AFR 689, DRK 137-1, VTTT 921-11, VTTT 919-1, AFR 676-B-1, AFR 593-1, and VTTT 919-8-1. Bean genotypes varied in their response to applied N as well. Most high yielding lines under N-limiting condition had poor response to added nitrogen. Their yield under no nitrogen was equivalent to the yield with 30 kg ha⁻¹ applied nitrogen. The results suggest lesser N requirement of fertilizer nitrogen for acceptable productivity under similar environments. Such genotypes appear promising for use by small-scale farmer who cannot afford expensive mineral fertilizers. The genotypes with adaptation to low N are red mottled, red kidney and navy seed types, widely accepted seed types on regional market.

Table 2. Bean lines yield with and without applied nitrogen, Mulungu, DRC 2003 A.

Entries	Market classes	Grain Yield with 0 kg ha ⁻¹ N	Grain Yield with 30 kg ha ⁻¹ N
Nm 12806-2A	Red Kidney	2798.1	2773.1
AND 932-A-1	Red mottled	2591.9	2300.0
RWK 10	Red Kidney	2560.6	3139.4
BW 12894-B-1	Red mottled	2526.9	3050.0
AFR 689	Red mottled	2323.1	2850.0
MwaSOLE	Dark tan	2316.9	3125.0
DRR 137-1	White/navy	2237.5	2431.3
VTTT 921-11-1	Red kidney	2195.6	3156.3
VTTT 919-1	Red mottled	2164.4	2420.6
AFR 676-B-1	White/navy	2066.3	1891.3
AFR 593-1	Red mottled	2012.5	2368.8
VTTT 919-8-1	Red kidney	2003.8	2587.5
VTTT 917-12	Red kidney	1941.9	2320.6
RAB 475-1	White/navy	1906.3	1868.8
FEB 200-1	Small red	1785.6	2476.9
TZ 3386-7-1	White/navy	1743.8	2723.1
NR 12633-5B	Red mottled	1737.5	2810.6
CAPSULA-1	Small red	1703.8	2591.9
MwaMAFUTALA (tolerant check)	Small red	1660.6	2828.8
POA 5-1	Red mottled	1654.4	2050.0
T 8426F11-6	White/navy	1639.4	1956.3
Nm 12805-4A	Red mottled	1612.5	1891.9
ARA 8-1B	White/navy	1543.8	2281.3
CAL172-2	Red mottled	1368.8	1616.3
NR 12634-1B-1	Red kidney	1364.4	1868.8
VTTT 917-6-2	Red kidney	1306.3	2304.4
FEB 176	White/navy	1293.8	2260.6
HM 21-7	Red mottled	1170.6	2039.4
VTTT 923-6-1	Red mottled	1031.3	1648.1
DOR 645A-1	Small red	1014.4	1543.8
CAL 160	Red mottled	941.3	1754.4
UBR(92)9-1-1	Pinto	925.0	1258.1
KIRUNDO (check)	Yellow	866.9	2079.4
VTTT 920-26	Red kidney	814.4	1539.4
BZ 12684-C-1	White/navy	800.0	2010.0
RWR 1742-1	Red kidney	695.6	1331.3
Mean		1714.4	2254.1
LSD (0,05)		336.8	
CV (%)		28.3	

At Selian, seed yield ranged from 466 to 2253 kg ha⁻¹. The following lines gave significantly higher seed yield than the local check Selian 97: T842-6F11-6A-1, DRK 137-1, ARA 8-5-1, TY 3396, RAB 475, BZ-12984-C-1, NR 12635-5A-1, KS-19-1, KS 55-1-1, T842-6F12-11-1, Nm 12656-8C, KS-40-7-1, Nm 12803-4C-4, UBR(92)25, EMP 264-5-1, RWR 1896-6. The genotypes selected at Selian were generally different from those identified as adapted to N-limiting condition at Mulungu. In fact, at the trial site, the N effects were not significant. The differences observed in yield might well be attributed to factors other than genetic variability to low nitrogen stress.

Low phosphorus

The performance of the best lines selected under low P was evaluated at Kakamega is presented in Table 4. Several lines were outstanding compared with the local released bean variety GLP 585. Considerable yield advantage up to 80% is observed compared with the local check. Such a substantial variability has been observed elsewhere in phosphorus efficiency in CIAT bean germplasm collection by Beebe et al. (1997). Again low P tolerance was found essentially in red mottled and red kidney groups, and only a few in small red and white/navy seed types.

Table 3. Performance of bean genotypes under N stress condition at Selian, Tanzania, 2003 A.

Entries	Market class	Grain yield kg ha ⁻¹
T842-6F11-6A-1	White navy	2253
DRK 137-1	White/navy	2135
ARA 8-5-1	White/navy	2118
TY 3396	White/navy	2117
RAB 475-1	White/navy	1985
BZ-12984-C-1	White/navy	1972
NR 12635-5A-1	Small red	1967
KS-19-1	Pinto	1959
KS 55-1-1	Pinto	1912
T842-6F12-11-1	Small red	1893
Nm 12656-8C	Small red	1863
KS-40-7-1	Pinto	1658
Nm 12803-4C-4	Red mottled	1628
UBR(92)25 (check)	White/Navy	1572
Selian 97 (check)	–	1351
Mean ⁽¹⁾		1294
CV (%)		32.2

⁽¹⁾Mean of 50 lines.

Table 4. Bean yield of selected market class entries at low P site, Kakamega, Kenya, 2002 (Rachier et al. 2002).

Entries	Market class	Yield kg ha ⁻¹
AFR-709-1	Red mottled	1352
Nm 126806-2A-1	Red kidney	1290
FOT 44-1	Red mottled	1289
T 842-6-9	Red kidney	1272
AND 1055-1	Red kidney	1266
NR 12634-13C-1	Red kidney	1145
NR 12634-1B-2	Red kidney	1144
NR 12634-9B-1	Red kidney	1103
NM 12803-4E-1	Red mottled	1041
NM 12656-7B-1	Navy	986
AFR 703-1	Red mottled	930
ARA 8-1B	White/navy	927
AND 932A-1	Red mottled	875
DFA 55-1	Small red	880
GLP 885(local check)	–	750

Low pH

The variety Mwasole was used as a check for low pH tolerance evaluation at Mulungu. This variety selected as aluminium tolerant is well adapted (Wortmann et al., 1995), and is widely grown in Eastern Congo under low fertility soil conditions (Njingulula, 2003). The seed yield data are presented under acid soil conditions (high aluminium) and under limed soil non stress conditions in Mulungu in Table 5. The genotypes varied widely in their performance under acid soil condition and in

their response to lime. With no lime, most test lines gave significantly higher yield than the sensitive check variety Kirundo, while only two lines VTTT 923-6-1 and HM 21-7 outperformed the tolerant check Mwa-Sole. Among these two elite lines, only the former is a new breeding line and the second HM 21-7 is an old variety adapted to acid soil and released in Burundi. In fact, it has been recognized that source of tolerance to aluminium toxicity is common in the germplasm from Great Lakes region (Wortmann et al., 1995). Several lines gave seed yield comparable to the tolerant check Mwasole, and tolerance to low pH soil conditions could be confirmed in these lines: AFR 593-1, ARA 8-5-1, AND 932-A-1, BZ 12984-C-1, VTTT 920-26, CAPSULA-1, VTTT 919-12, CAL 172-1, AND 1056-1, UBR(92)9-21. Among the above 12 promising acid tolerant materials identified at Mulungu, six are red mottled, two red kidney, two white/ navy, one small red and one pinto.

At Antsirabe (Table 6), several lines outperformed the local check Soafianarana and improved check Goiano Precoce. More white/navy seed type in addition to red mottled are selected as aluminium tolerant. Most genotypes selected as tolerant to aluminium toxicity at Antsirabe were the same at Mulungu. The following lines gave consistently better yield under acid aluminium toxic soil at these two low pH sites: AND 1056-1, AND 932-A-1, ARA 8-1B, BZ 12984-C-1 and VTTT 920-26. Aluminium toxicity tolerance could be confirmed in these genotypes.

The evaluation results at Gikongoro, Rwanda are presented in Table 7. Many lines gave higher yield than the tolerant checks 714 Acc and RAB 478. However only 3 lines, AND 93-A-1, BZ 12894-C-1 and AFR 593-1 were also identified as tolerant to aluminium at the other low pH sites Mulungu and Antsirabe.

Although the genotypes selected to be aluminum tolerant at three low pH sites do not coincide, a few outstanding materials performed consistently well across sites. The variability across site could be attributed to the difference in adaptation to local environments (Wortmann et al., 1995).

Multiple tolerances

Several bean lines that had consistently high yield under different stresses and across sites are identified having tolerance to one, two or even all three soil constraints considered. BZ 12894-C-1, AND 932-A-1,

Table 5. Bean lines yield without and with lime, Mulungu, DRC, 2003 A.

Entries	Market classes	Grain yield with 0 t ha ⁻¹ lime (kg ha ⁻¹)	Grain yield with 2 t ha ⁻¹ lime (kg ha ⁻¹)
VTTT 923-6-1	Red mottled	1494.0	1588.1
HM 21-7	Red mottled	1316.9	1455.3
AFR 593-1	Red mottled	1040.3	1801.1
MWASOLE (tolerant check)	Dark tan	998.8	1264.4
ARA 8-5-1	White/navy	957.3	1394.4
AND 932-A-1	Red mottled	932.4	1206.3
BZ 12984-C-1	White/navy	866.0	874.3
VTTT 920-26	Red kidney	835.5	824.5
CAPSULA-1	Small red	830.0	702.7
VTTT 919-12	Red kidney	771.9	1048.6
CAL 172-1	Red mottled	763.6	600.4
AND 1056-1	Red mottled	752.5	1103.9
UBR(92)9-21	Pinto	730.4	1350.1
Nm 12806-21	Red kidney	724.9	1261.6
T 8426F11-6	White/navy	675.1	1084.5
BZ 12894-B-1	Red mottled	658.5	1247.8
VTTT 921-11	Red kidney	628.0	1178.6
MWAMAFUTALA (check)	Small red	625.3	1510.6
ARA 8-1B	White/navy	614.2	841.1
UBR(92)25-25-1	White/navy	583.8	1278.2
AFR 676-B-1	White/navy	583.8	1106.7
FEB 176	White/navy	569.9	1087.3
NR 12633-5B	Red mottled	531.2	910.2
RAB 475-1	White/navy	520.1	1148.2
NR 12634-1B	Red kidney	486.9	827.2
VTTT 917-6-2	Red kidney	481.4	758.1
KIRUNDO (check)	Yellow	481.4	987.7
RWK 10	Red kidney	481.4	866.0
TZ 3386-7-1	Carioca	417.8	713.8
BW 1294-B-1	Red mottled	415.0	846.6
CAL 160	Red mottled	412.2	702.7
DRR 137-1	White/navy	392.9	796.8
VTTT 919-8-1	Red kidney	387.3	785.7
DOR 645A-1	Small red	365.2	697.2
VTTT 917-12	Red Kidney	343.1	462.0
AFR 689	Red mottled	337.5	724.9
Mean		663.8	
LSD (0,05)		128.5	
CV (%)		47.1	

DRK 137-1, Nm 12806-2A are outstanding across sites and over all stresses, high aluminum toxicity, low N and P availability. Several other lines have manifested tolerance to two stresses: ARA 8-B-1, AFR 709-1, AFR 703-1 and AND 1055-1 are tolerant to low P and low pH; RWK 10, ARA 8-5-1, and T 842-6F11-6A-1 tolerant to low N and low pH. These appear to have multiple tolerances to edaphic stresses and good adaptation at all environments. They are likely to perform well under very low fertility prevailing in small-scale farmers' fields prevailing in small-scale farms.

Conclusion

A set of 300 genotypes of five market class seed types have been evaluated in various agro-ecologies at six different sites in Eastern and Central Africa for their tolerance to the edaphic stresses recognized to be regionally important. These stresses are soil acidity, phosphorus deficiency and nitrogen deficiency. Considerable genetic variability in bean germplasm with respect to soil acidity, low phosphorus and low nitrogen is observed in all market classes. Many lines were

Table 6. Performance of selected lines under low pH at Antsirabe, Madagascar, 2002/2003.

Entries	Market class	Grain Yield Kg ha ⁻¹
AND 1056-1	Red mottled	1936.0
TZ 3399-12-1	White/Navy	1850.0
AFR 684	White/navy	1806.6
VTTT 915-11	Red Kidney	1756.8
Nm 12805-4A-1	Red mottled	1728.7
DOR 733-1	White/navy	1609.5
AND 932-A-1	Red mottled	1590.0
FEB 187	White/Navy	1542.7
GOIANO PRECOCE (tolerant check)	White	1536.7
CAL 160	Red mottled	1507.3
VTTT 915-12	Red mottled	1461.3
ARA 8-1B	White/Navy	1397.0
BZ 12984-C-1	White/Navy	1395.3
VTTT 920-26	Red Kidney	1371.3
FEB 200-1	Small red	1154.1
VTTT 917-12	Red kidney	1150.7
AFR 702	Red kidney	1129.7
NR 12798-4A-1	Red kidney	1111.3
RWK 10	Red kidney	1034.0
AFR 709-1	Red mottled	1002.7
MX 3016-15	White/navy	959.2
POA 5-1	Red mottled	955.3
AFR 684-1	White/Navy	928.0
SOAFIANARANA (local check)		227.4
Mean		1272.6

Table 7. Grain yield of lines selected for tolerance to high soil Al levels under high and low Al stress at Gikongoro, Rwanda 2003A.

Entries	Market classes	Grain yield with 0.5 t ha ⁻¹ lime (kg ha ⁻¹)	Grain yield with 2.5 t ha ⁻¹ lime (kg ha ⁻¹)
VTTT 916-3-1	Red mottled	916	658
DB 190-74-1	White/navy	851	940
RA 13151-1	Red kidney	824	861
BZ 12894-C-1	Red mottled	798	1128
VTTT 917-17-1	Red kidney	794	847
VTTT 921-11-1	Red kidney	746	1579
RAB 478 (check)	Red	732	1095
Nm 12634 1A-1	Red kidney	726	1295
VTTT 920-16-1	Red mottled	706	545
Nm 12634-1	Small red	697	925
Nm 12856-8C	Small red	693	652
UBR(92)3-1	Pinto	693	691
Nm 12634-1B-1	Red kidney	661	1021
NR 12638-6-1	White/navy	647	1374
AND 932-A-1	Red kidney	616	1468
CAL 160	Red mottled	606	672
FOT 7	Red mottled	606	672
AFR 703-1	Red mottled	573	693
714 Acc(check)	Black	572	756

identified having tolerance to a single stress, while several had multiple tolerance. These promising lines are: BZ 12894-C-1, AND 932-A-1, DRK 137-1, Nm 12806-2A, ARA 8-B-1, AFR 709-1, AFR 703-1 and AND 1055-1, RWK 10, ARA 8-5-1, T 842-6F11-6A-1. Unlike the cultivars selected for tolerance to edaphic stresses in our previous work (Lunze, 1994; Wortmann et al., 1995), the materials identified are found having the characteristics that meet different regional market requirements.

The genetic approach, e.g. tolerant bean varieties, is a fast adoption soil fertility management option. The new tolerant bean varieties identified have opened opportunity for higher bean productivity on acid soils and those with limited N and P supply and allowed small scale farmers improve at no additional cost their bean production for food and sale. As Singh (2001) stated, development of high yielding cultivars adapted to low soil fertility and low input sustainable system is essential to maximize yield of common bean in order to enhance food security, reduce production costs and generate income.

Acknowledgements

The authors are grateful to the directors of the research institutions and support staff and technicians of the bean programs that have hosted field trials. The study is supported by Eastern and Central African Bean Research (ECABREN) of ASARECA through Pan-African Bean Research in Africa (PABRA) funding.

References

- Beebe S., Lynch J., Galwey N., Tohme J. and Ochoa I. 1997. A geographical approach to identify phosphorus-efficient genotypes among landraces and wild ancestors of common bean. *Euphytica* 95:325–336.
- Dreschel P., Steiner K.G. and Hagedorn F. 1996. A review of potential of improved fallow and green manure in Rwanda. *Agroforestry Systems* 33: 109–136.
- Esilaba A.O., Byalebeka J.B., Nakiganda A., Mubiru S., Delve R.J., Ssali H. and Mbalule M. 2001. Integrated Nutrient Management strategies in Eastern Uganda. CIAT, Kampala. CIAT Africa Occasional Publication Series, No. 35. 71pp.
- Kimani P., Buruchara R., Ampofo K., Pyndji M., Chirwa R. and Kirkby R. 2001. Breeding bean for smallholder farmers in Eastern, Central and Southern Africa: Constraints, Achievements and Potential. In Proceedings of PABRA Millennium Synthesis. Arusha, Tanzania, 28 May-1 June, 2001.

- Lunze L. 1994. Screening for tolerance to aluminum toxicity in bean. In. *Bean Improvement for Low Fertility in Soils Africa: Proceedings of a Working Group Meeting*. Kampala, Uganda, 23-26 May 1994. Wortmann C.S. (Ed). Network on Bean Research in Africa. Workshop Series. No. 25. CIAT.
- Lunze L., Kimani P.M., Ndakidemi P., Rabary B., Rachier G.O., Ugen M.M. and Nabahungu L. 2002. Selection of bean lines tolerant to low soil fertility conditions in Africa. *Bean Improvement Cooperative*, BIC 45:182–183.
- Ngongo M. and Lunze L. 2000. Espèces d'herbe dominante comme indice de la productivité de sol et de la réponse du haricot commun à l'application du compost. *African Crop Science J.* 8 (3): 251–261
- Njingulula M. 2003. Etude de l'impact socio-économique des variétés améliorées du haricot dans le système de culture paysan au Congo, République Démocratique. *Proceedings of a Regional Workshop to Develop a Work Plan for Impact Assessment Studies and Monitoring and Evaluation*. Kampala, Uganda. . PABRA, CIAT. pp 83–87.
- Rachier G.O., Lunze L. and Kimani P.M. 2002. Selection of bean varieties tolerant to Low Soil Phosphorus at Kakamega, Kenya. Paper presented at Soil Fertility and Bean Improvement for low Fertility Soil (BILFA) Working Group Meeting at Awassa, Ethiopia, 11 November 2002.
- Rutunga V. 1997. Sols acides de la région d'altitude de la Crête Zaïre-Nil (Rwanda): Potentialités agricoles et forestières. Lengo Publishers, Nairobi, 68pp.
- Singh S.P. 2001. Broadening the genetic base of common bean cultivars: a review. *Crop Science* 41: 1659–1675.
- Singh S.P., Teran H., Munoz C.G., Osorno J. M., Takegami J.C. and Thung M.D.T. 2003. Low Soil fertility Tolerance in Landraces and Improved Common bean genotypes. *Crop Science* 43(1): 110–119
- Wortmann C.S., Lunze, L., Ochwoh V.A. and Lynch J.P. 1995. Bean improvement for low fertility soils in Africa. *African Crop Science J.* 3(4): 469–477.
- Wortmann C.S., Kirkby R.A., Aledu C.A. and Allen J.D. 1998. Atlas of common bean (*Phaseolus vulgaris* L.) Production in Africa, CIAT Cali, Colombia.

Combining *Tithonia diversifolia* and minjingu phosphate rock for improvement of P availability and maize grain yields on a chromic acrisol in Morogoro, Tanzania

S.T. Ikerra*, E. Semu and J.P. Mrema

Mlingano Agricultural Research Institute, P.O. Box 5088, Tanga, Tanzania; *Author for correspondence (e-mail: susikera@yahoo.com)

Key words: Maize grain yield, Minjingu phosphate rock, Nutrient concentration, P pools, Tithonia green manure, Triple super phosphate

Abstract

A 2-year field experiment was conducted to evaluate the effects of *Tithonia diversifolia* green manure combined with either Minjingu phosphate rock (MPR) or triple super phosphate (TSP) on soil chemical properties that influence P availability, P pools and maize grain yields, on a Chromic Acrisol in Morogoro, Tanzania. Leafy biomass of tithonia was applied before maize planting for two consecutive growing seasons. Treatments compared were the control, MPR and TSP each at 80 kg P ha⁻¹; tithonia alone at 2.5, 5.0, and 7.5 Mg ha⁻¹ dry matter and tithonia combined with MPR or TSP at 40 kg P ha⁻¹. Tithonia led to significant increases in soil pH, exchangeable Ca, labile (resin and NaHCO₃-Pi), and moderately labile inorganic P (NaOH-Pi). It reduced exchangeable Al and P sorption. Application of MPR alone had liming effects and resulted in increase in labile P. Combining tithonia with MPR had similar but more intense effects. Triple superphosphate alone led to acidification and this was reversed when TSP was co-applied with tithonia. Increasing the application rates of tithonia either alone or in combination with TSP or MPR led to more pronounced liming effects but the differences between 2.5 and 5.0 Mg tithonia ha⁻¹ were not significant due to moisture stress that was experienced during the season. The P and Ca concentrations of the maize plants at tasselling increased with the application of tithonia alone or combined with MPR or TSP, and were significantly correlated with maize grain yields ($r = 0.75$ and 0.64 for MPR and TSP, respectively). Tithonia added consecutively for 2 years increased total maize grain yields by 70% compared to that in the control. The relative agronomic effectiveness (RAE) of MPR increased from 46% in the first year of application to >142% in the second year, indicating that the initially slow dissolution of MPR improved by combined application of tithonia and MPR, attributed to reduction of P sorption. It is concluded that tithonia can enhance P availability from the Chromic Acrisol through modification of soil properties associated with P transformation and availability. In cases where tithonia is found within the farmers' fields its combined application with MPR can increase maize yields at a much-reduced cost associated with tithonia procurement.

Introduction

In Tanzania, as elsewhere in Sub-Saharan Africa (SSA), continuous cropping without adequate

fertilization has led to soil fertility depletion and subsequent low crop yields. For instance, N, P and K uptake from soils, and other losses and transformations have led to negative balances in

This article has been previously published in the journal "Nutrient Cycling in Agroecosystems" Volume 76 Issues 2–3.

arable lands to the magnitudes of $-27 \text{ kg ha}^{-1} \text{ year}^{-1}$ of N, $-4 \text{ kg ha}^{-1} \text{ year}^{-1}$ of P, and $-18 \text{ kg ha}^{-1} \text{ year}^{-1}$ of K (Smaling et al. 1993). Phosphorus deficiency associated with P fixation is one of the major causes of declining crop yields in Tanzania (Ikerra and Kalumuna 1992; Mnkeni et al. 1994) in highly weathered soils, which constitute about 52% of all the Tanzania soils (De Pauw 1984).

Use of mineral or organic amendments is a possible option to reverse this trend of declining crop yields. However, use of these amendments is constrained by several socio-economic limitations like high prices of inorganic fertilizer, their timely availability, high transport costs and lack of credit facilities. Although most organic soil amendments are low in P (Palm et al. 1997), they can improve soil parameters such as soil pH, exchangeable Al and Ca, which are closely related to P fixation (Warren 1992). Organic soil amendments also improve P availability through reduction of the P sorption capacities of soils (Easterwood and Sartain 1990; Nziguheba et al. 2000) and supply of the P released during their decomposition (Nziguheba et al. 2002). Use of high rates of inorganic P fertilizers has been suggested as one of the strategies for managing high P-fixing soils (Sanchez and Jama 2002). However, this is limited by the high costs involved in purchasing and applying the fertilizers. Integrated use of organic soil amendments with modest rates of locally available inorganic P sources like phosphate rocks could be a cheaper and more appropriate option for small scale peasant farmers in terms of reduced costs, increased yields and enhanced and sustained soil fertility.

Minjingu phosphate rock is a sedimentary biogenic phosphate deposit found around lake Manyara in Arusha, Tanzania. The estimated reserve of this deposit is 10 million tons (Van Straaten 2000). The P concentration ranges from 13–15%, with neutral ammonium citrate solubility (NAC) of 4.4% (Szilas 2002).

Use of MPR as an alternative P source to TSP has received attention in Tanzania since the 1960s (Anderson 1965; Ikerra et al. 1994; Szilas 2002). Research findings from eight agro-ecological zones in Tanzania indicate that TSP is superior to MPR in the first year of application but MPR had a

better residual effect (Ngatunga and Deckers 1984; Mnkeni et al. 1991; Szilas 2002). The superior and long lasting residual effect was attributed to a continual release of P from MPR. Organic anions like oxalates and malates, produced during decomposition of organic materials, competed with P for the P fixation sites (Hue 1991; Iyamuremye et al. 1996) through anion exchange processes and blocked the P fixation sites (Reddy et al. 1980; Easterwood and Sartain 1990), making the solubilized P more available. Ikerra et al. (1994) observed that the agronomic effectiveness of MPR increased when it was combined with high quality farmyard manure but not with low quality compost. In contrast, Mowo (2000) found that composted farmyard manure and MPR had no effect on MPR dissolution when co-applied on a Rhodic Ferralsol. This was attributed to the high pH of farmyard manure and a lack of proton supply.

Farmyard manure, however, is not available to all the farmers, implying that locally available green manures on the farm could be evaluated. Although many studies have concentrated on the use of these materials for nitrogen supply (Ikerra et al. 1999, 2001a) little has been reported in Tanzania on their contribution to P availability and transformations in soils and their effects on soil properties related to P availability. Integrated use of these materials with modest rates of soluble P fertilizers like TSP has been documented in the region (Nziguheba et al. 2000, 2002). Combining green manures with locally available inorganic P sources like MPR could reduce the cost on P fertilizers, improve nutrient balances and crop yields, and sustain soil fertility.

Although information about soil P fractions is useful in predicting the bio-availability of P in soils, and in monitoring the fate of P after fertilization with different inorganic and organic P sources, such information is still lacking in the published work dealing with MPR use in Tanzania.

In view of the foregoing knowledge gaps, this study was carried out to evaluate the effects of combined application of MPR or TSP with *Tithonia diversifolia* green manure on some soil chemical properties associated with P availability, soil P pools, and grain yields of maize grown on a Chromic Acrisol in Morogoro, Tanzania.

Materials and methods

Study site

A field experiment was conducted in 2002 and 2003 in the Magadu area of the Sokoine University of Agriculture (SUA) farm, located at 6°51' S and 37°39' E, at an altitude of 568 m asl in Morogoro, Tanzania. The area had been under fallow for the previous five years. The area has a mean annual total rainfall of 750–1,000 mm, with two growing seasons. The long rains, from mid February to May (277–530 mm), are more reliable and better distributed, while the short rains, from October to December (298–410 mm), are light and erratic. The study was undertaken during the long rain seasons. The soil at the experimental site was an isohyperthermic ustic, fine clayey kaolinitic, kanhaplic Haplustults (Soil Survey Staff 1975) or Chromic Acrisol (WRB 1998).

Soil sampling and analysis

Prior to setting up the trial, 20 surface (0–15 cm depth) soil samples were randomly collected in the 0.5 ha experimental site and thoroughly mixed by hand to form one composite sample. The composite sample was air-dried, sieved through a 2-mm sieve and subsequently analysed for site characterization. In all the two years (2001 and 2002) soil samples were also collected at the maize tasselling stage (55 days after planting) and analysed for pH, Ca, exchangeable Al and P sorption capacity.

The composite soil sample was analysed for pH (1:2.5 water) according to McLean (1965). Exchangeable Al was extracted by 1 M KCl and determined titrimetrically using the method of McLean (1965). Organic C was determined by sulphuric acid–dichromate digestion and colorimetric determination of Cr^{3+} (Anderson and Ingram 1993). Total nitrogen (N) was determined by the Kjeldahl method (Bremner and Mulvaney 1982). Nitrate nitrogen (NO_3^- -N) was extracted using 2 M KCl and determined after reduction with cadmium (Dorich and Nelson 1984) while inorganic ammonium was determined in the 2 M KCl extract by the salicylate–hypochlorite colorimetric method (Anderson and Ingram 1993). Total inorganic nitrogen was taken as the sum of

nitrate N and ammonium N. The CEC and exchangeable bases were determined following extraction using 1 M NH_4 -acetate at pH 7 (Rhodes 1982). Zinc and Fe was extracted by EDTA or DTPA and measured by Atomic Absorption Spectroscopy according to Lindsay and Norvell (1978). Particle size distribution was determined according to Gee and Bauder (1986). Anion resin extractable P was determined by the method of Sibbesen (1978).

Soil samples were collected at tasselling in the second season, and available P was characterized by sequential extraction following the method of Tiessen and Moir (1993). In the sequential fractionation procedure the different fractions are interpreted as follows: Resin-Pi (RP), stated as resin-extractable inorganic phosphate represents inorganic P that is in equilibrium with the soil solution. Sodium bicarbonate P (Bic-P) inorganic and organic P (Bic-Po) represents the weakly adsorbed Pi and easily hydrolysable organic P that is plant available. Sodium hydroxide extractable inorganic P (NaOH-Pi) and organic P (NaOH-Po) are less available to plants and are thought to be associated with amorphous and crystalline Al and Fe hydroxides and clay minerals. Dilute hydrochloric acid extractable P (HCl-Pi) is that P associated with apatite or octacalcium P.

The P sorption index was determined by the method of He et al. (1996) but with an initial solution P concentration of 50 mg l^{-1} rather than 150 mg l^{-1} to avoid precipitation of calcium phosphate at high P concentration. A 2.5 g soil sample was equilibrated by shaking for 18 h with 50 ml of 0.01 M CaCl_2 containing 50 mg P l^{-1} (as KH_2PO_4). Phosphorus in the equilibrium solution was determined by the phosphomolybdate colorimetric method (Murphy and Riley 1962). The P sorption index was then calculated as follows.

$$\text{P sorption index} = \frac{\text{sorbed P (mg P kg}^{-1}\text{)}}{\log_{10} \text{P concentration (mg P l}^{-1}\text{) in the equilibrium solution.}}$$
 The P adsorption maximum (P_{max}) was determined according to Fox and Kamprath (1970).

Analysis of MPR

Minjingu PR, collected from the Minjingu factory in Babati, Arusha, Tanzania was ground and

sieved such that 80% of the material passed a 0.15 mm sieve (100 mesh). It was analysed for pH, total P, calcium carbonate, calcium oxide and neutral ammonium citrate (NAC)-extractable P. The pH was measured in a 1:2.5 MPR–H₂O suspension (McLean 1965). Calcium carbonate was determined by the acidification-titration procedure (Loeppert and Suarez 1996), and its equivalence computed according to Tisdale et al. (1993). Calcium oxide content was determined by the wet digestion method using HF–H₂SO₄–HClO₄ (Hossner 1996). Neutral ammonium citrate soluble P was determined as described by McClellan and Gremillion (1980). Total P was determined according to Okalebo et al. (2002).

Analysis of tithonia green manure

Tithonia green manure (GM) samples were thoroughly washed and rinsed using distilled water, dried, ground and analysed for pH, N, P, K, Ca, Mg, C, lignin and polyphenol. The samples were analysed for pH in water at a manure: water ratio of 1:5, total N (Bremner and Mulvaney 1982), and P, K, soluble and organic C (Anderson and Ingram 1993). Lignin and polyphenols were determined by the acid detergent method and the revised Folin – Denis method, respectively (Anderson and Ingram 1993).

Plant sampling and analysis

To determine nutrient uptake at 45 days after planting, six maize plants per plot outside the net plot area were randomly sampled and cut using a knife at about 2–2.5 cm above the soil surface. The maize stumps were uprooted using a hoe after prior wetting of the surrounding soil to loosen it, and washed by spraying water to retain most of the small roots. The maize shoots and roots, and *tithonia* GM samples were oven dried at 70 °C to constant weight and ground to pass through a 0.5 mm sieve.

The dried maize shoots and roots were analysed for total P and Ca using the same methods as for *tithonia* GM. The data were used to calculate P and Ca uptake at tasselling, by multiplying the dry matter yields and the nutrient concentrations.

Experimental design

The experiment was established during the long rains of 2001. Twelve treatments, in a randomized complete block design with three replications, were randomly allocated to 4×7 meter plots. The treatments included a control (no P); MPR and TSP at 80 kg P ha⁻¹; *tithonia* alone at 2.5, 5.0, or 7.5 Mg dry matter ha⁻¹ and MPR and TSP at 40 kg P ha⁻¹ each combined with *tithonia* at 2.5, 5.0, or 7.5 Mg dry matter ha⁻¹. The experimental plots were left fallow during the short rain periods (October–December).

During the long rains of 2001 and 2002, fresh *tithonia* leaves and rachis were surface applied and incorporated into the soil to 15 cm depth by hand hoes one-week before planting. Minjingu rock phosphate was broadcasted and incorporated into the soil by a hand hoe at planting.

Triple superphosphate was banded along the rows and incorporated into the soil along the rows at planting. Ammonium sulphate at 80 kg N ha⁻¹ was split applied in the plots without *tithonia*, one third at planting and two-thirds at 5 weeks after planting. Following chemical analysis, the *tithonia* green manure was found to contain 4% N. This high N content was considered enough for supplying N initially and hence no inorganic N application was done at planting in the plots that received *tithonia* green manure. Since decomposition of *tithonia* is generally fast (Gachengo et al. 1999), there was a need of top-dressing the plots with *tithonia* 5 weeks after planting to avoid N deficiency. Thus, in the plots with *tithonia*, two thirds of the basal N (i.e. 53.3 kg N ha⁻¹) was top-dressed 5 weeks after planting. In plots without *tithonia*, potassium, as potassium sulphate, was applied at 50 kg K ha⁻¹ at planting. No K application was made in the plots that had received *tithonia* GM because *tithonia* has a high K content (4%). Zinc, as zinc sulphate at 5 kg Zn ha⁻¹, was applied at planting time because the Chromic Acrisol was deficient in zinc (Table 1).

In both years, after the treatments had been assigned, two maize (*Zea mays* L. var. TMV-1) seeds were planted per hill at a spacing of 75 × 30 cm, and were thinned to one plant per hill 21 days after planting. Weeding was done twice per season using hand hoes. Harvesting was done in June by opening the maize cobs, removing the husks, and hand shelling. Maize grain yields were expressed at 12.5%

moisture content. After harvesting, all the maize stover and weeds were removed from the plots to reduce confounding effects from additional organic inputs of different qualities.

Statistical analysis and mathematical calculations

Statistical analysis

Analysis of variance was conducted using the general linear models procedure (GLM) of the SAS program (SAS Institute 1995) to determine the effects of treatments on soil parameters, P sorption index, P availability indices, nutrient uptake and maize grain yields. Statistical significances were determined at the 0.05 level of probability. Means were compared using the Duncan's New Multiple Range Test.

Mathematical calculations

Relative agronomic effectiveness

The relative agronomic effectiveness (RAE) of MPR compared to TSP was calculated as:

$$\text{RAE} = (Y_{\text{MPR}} - Y_{\text{control}}) / (Y_{\text{TSP}} - Y_{\text{control}}) \times 100$$

where Y_{MPR} is maize grain yield from MPR treatment at the rate of 80 kg P ha⁻¹, Y_{TSP} is maize grain yield from TSP treatment at the rate of 80 kg P ha⁻¹, and Y_{control} is maize grain yield from the control treatment (-P, +N, +K).

Results

Characteristics of the soil, MPR and tithonia green manure used

The soil used in this experiment was very acidic, with low extractable P, low exchangeable Ca and moderate aluminium saturation (Table 1). It had low organic matter content and low cation exchange capacity (Table 1). The sample of MPR used had 13% total P, 35.5% Ca and 3.6% NAC-soluble P, indicating a moderate to high reactivity of the material (Table 2). The P, N, lignin and polyphenol contents of the tithonia GM used had high contents of Ca and K (Table 3) that would supplement the low levels of Ca and K in the Chromic Acrisol used.

Effect of tithonia green manure with MPR or TSP on soil properties determined at tasselling time in 2002

Soil pH

In the two seasons, soil pH increased significantly ($P \leq 0.0001$) with increasing rate of tithonia application. In 2002, there was no difference in soil pH between the 2.5 and 5.0 Mg ha⁻¹ treatments (Table 4). Combining tithonia at this rate with MPR (40 kg ha⁻¹) increased soil pH compared to

Table 1. Some physiochemical properties of the top-soil (0–15 cm) of the experimental site at Morogoro, Tanzania.

Parameter	Value	Rating	Reference
pH (H ₂ O) (1:2.5)	4.8	Very acidic	Landon (1991)
pH _{KCl} (1:2.5)	4.4	–	–
Organic C (g kg ⁻¹)	9.9	Low	Landon (1991)
Total N (g kg ⁻¹)	0.9	Low	Landon (1991)
Mineral N (mg kg ⁻¹)	6.8	–	–
Total P (mg kg ⁻¹)	0.3	Very Low	Landon (1991)
Available P (mg kg ⁻¹)	–	–	–
Bray-1	6.4	Low	Singh et al. (1977)
Resin	4.1	Low	Landon (1991)
Exch. Al (cmol _c kg ⁻¹)	3.2	Moderate	Landon (1991)
Exch. bases (cmol _c kg ⁻¹)	–	–	–
Ca	1.80	Low	Landon (1991)
Mg	1.34	Medium	Landon (1991)
K	0.53	Medium	Landon (1991)
Na	0.05	–	–
CEC (pH 7)	8.40	Low	Landon (1991)
DTPA (mg kg ⁻¹)	–	–	–
Zn	1.04	Low	Lindsay and Norvell (1978)
Fe	60.69	Very high	Lindsay and Norvell (1978)
Texture (%)	–	–	–
Sand	32	–	–
Silt	13	–	–
Clay	55	–	–

Table 2. Chemical characteristics of MPR and TSP used in the study.

Parameter	Magnitude	
	MPR	TSP
pH (H ₂ O)	8.5	2.1
P (%)	13.0	19.4
Ca (%)	35.5	13.5
CaCO ₃ (%)	6.9	Nil
Bray 1-P (%)	0.01	20.1
NAC solubility (%)	3.6	43.7

that of the control. MPR at 80 kg P ha⁻¹ had a similar effect on pH as had *Tithonia*, but TSP reduced soil pH relative to that of the control. The effect of combining TSP with *tithonia* on soil pH was generally similar to that of *tithonia* alone.

Exchangeable Ca

The trend of exchangeable Ca was similar to that of soil pH. *Tithonia* increased exchangeable Ca compared to that in the control (Table 4). Combining *tithonia* with MPR further increased exchangeable Ca relative to that under *tithonia* alone. Similarly, TSP increased exchangeable Ca when compared to that in the control and when combined with *tithonia*.

Exchangeable Al

Tithonia at all rates significantly ($P < 0.0001$) reduced exchangeable Al. Combining *tithonia* with MPR had a similar effect. TSP increased exchangeable Al in 2001 but not in 2002, while combining it with *tithonia* gave a similar effect as *tithonia* or MPR applied alone.

Phosphate sorption

There was a decrease in P sorption by *tithonia* as indicated by decrease in the Langmuir adsorption maximum (P max) in all treatments as compared to that in the control (Table 4). Similarly, soil P sorption capacity, as indicated by the PSI determined on selected treatments, was decreased by 32% due to *tithonia* applied at 5 Mg ha⁻¹ compared to that in the control. *Tithonia* alone and when combined with MPR had a similar depressing effect on the PSI. A similar depressing effect on PSI was obtained with TSP alone. Though not statistically different from each other, MPR had a slightly higher depressing effect on PSI than that of TSP. Combination of TSP with *tithonia* led to the lowest PSI that was 54% lower than that in the control. The decrease in PSI had a significant ($P \leq 0.0001$) negative correlation ($r = -0.81$), $P < 0.0001$) with maize grain yields in 2002.

Soil P pools

The treatments (namely *tithonia* alone, or combined with MPR or TSP) significantly ($P \leq 0.0001$)

Table 3. Chemical characteristics of *tithonia* used in the experiments in Magadu.

	pH (water)	N mg kg ⁻¹ (DM)	P mg kg ⁻¹ (DM)	K mg kg ⁻¹ (DM)	Ca mg kg ⁻¹ (DM)	Mg mg kg ⁻¹ (DM)	T C %	C _s %	Lig %	Poly %	L/P	C _s /P _t
<i>Tithonia</i>	6.9	40	4.6	40.6	20.3	6.4	41.4	2.6	7.2	3.17	2.2	5.8

C_s = soluble carbon, P_t = total phosphorus, Lig. = lignin, Poly. = polyphenols, TC = total carbon, DM = dry matter.

Table 4. Some soil characteristics from the field site in Morogoro as affected by different treatments at 45 days after planting in 2001 and 2002.

Treatment	pH (water)		Ca (cmol (+) kg ⁻¹)		Al (cmol (+) kg ⁻¹)		P-max (mg P kg ⁻¹)	PSI
	2001	2002	2001	2002	2001	2002		
Control (-P)	4.80f	4.57d	1.73h	1.78h	0.55b	0.36a	717 a	231
<i>Tithonia</i> 2.5 t ha ⁻¹	5.20cde	4.85b	2.47def	2.45ef	0.22de	0.25b	606 c	nd
<i>Tithonia</i> 5 t ha ⁻¹ (T5)	5.40b	4.80bc	2.53def	2.44ef	0.20e	0.22bc	592 c	157
<i>Tithonia</i> 7.5 t ha ⁻¹	5.30bc	5.30a	2.90c	2.57e	0.10fg	0.22bc	538 de	nd
MPR (P 80)	5.22cde	4.83bc	4.45a	3.32b	0.17ef	0.20bc	550 d	133
TSP (P 80)	4.70g	4.34e	3.73b	2.24g	0.73a	0.39a	641 b	144
MPR (P 40) + T2.5	5.14e	4.86b	2.44def	2.34fg	0.40c	0.22bc	518 def	nd
MPR (P 40) + T5	5.14e	4.88b	2.26fg	2.84d	0.28d	0.17c	512 ef	149
MPR (P 40) + T7.5	5.57a	4.87b	2.67cde	3.12c	0.08gh	0.20bc	525 ed	nd
TSP (P 40) + T2.5	5.16de	4.68cd	1.98gh	2.45ef	0.18e	0.21bc	602 c	nd
TSP (P 40) + T5	5.18de	4.82cb	2.32efg	2.55e	0.10fg	0.18c	592 c	107
TSP (P 40) + 7.5	5.30bc	5.36a	2.69cd	3.68a	0.01h	0.02d	525 de	nd
CV (%)	1.33	2.04	8.12	3.35	19.03	16.06	3.46	

Means followed by the same letter in the same column are not significantly different $P < 0.05$ according to DMRT. nd, not determined.

influenced the different P pools (namely resin P, Bic-Pi, Bic-Po, NaOH-Pi, NaOH-Po, HCl-Pi). Tithonia significantly increased resin P compared to that in the control (Table 5). The resin P fraction increased with increasing tithonia green manure rates but there were no significant differences between 2.5 and 5.0 Mg tithonia ha⁻¹. The significant increase in Bic-Pi fraction was obtained at a rate of 7.5 Mg tithonia ha⁻¹. Although there was an increase in moderately labile P pool (NaOH-Pi) with an increase in tithonia application rate compared to control, the increase at the lowest rate was not significant. Combining tithonia with MPR or TSP resulted in a four-fold increase of labile P (Resin P) compared to that in the control but the effect on moderately labile P (NaOH-Pi) was only one and half fold. The effect of tithonia green manure on organic P pools varied from one extractant to the other. Although tithonia significantly increased Bic-Po at all rates, its influence on NaOH-Po was the same or lower than the control.

With the exception of TSP for the NaOH-Po fraction, both MPR and TSP had a drastic effect on inorganic P pools compared to those in the control but had no effect on organic P pools. Most of the applied inorganic P (from MPR or TSP) was extracted in the NaOH-Pi form, a fraction associated to the P chemisorbed by hydrous oxides of Fe and Al, and hence relatively unavailable to plants. The NaOH-Pi fraction from MPR (100 mg kg⁻¹) at 80 kg P ha⁻¹ was smaller than that from TSP (118 mg kg⁻¹) at the same P rate. Addition of MPR produced

the largest HCl-Pi fraction that is related to P in Ca-P forms. Tithonia green manure alone had similar or no effect on HCl-Pi compared to that in the control however, its combination with either MPR or TSP resulted in larger HCl-Pi than that of the control.

Maize grain yields

The maize grain yields varied from year to year due to drought and termite attacks. However, the applied treatments significantly ($P \leq 0.0001$) increased maize grain yields compared to that in the control in both seasons (Table 6). Both MPR and TSP significantly ($P \leq 0.0001$) increased maize grain yields in both seasons. The relative agronomic effectiveness of MPR increased from 46% in the first year to 142% in the second. In the first year (2001), maize yields from tithonia alone were similar to those when tithonia was combined with MPR but the yields from tithonia alone were significantly ($P \leq 0.0340$) lower in the second year (2002). Combining tithonia with TSP produced significantly higher maize grain yields ($P < 0.0014$) than when tithonia was applied alone in year two. When the total yield for 2 years is considered, the yield increase was 70% for tithonia alone, and 109% when, tithonia was combined with MPR. Maize grain yields obtained in the year 2002 correlated with shoot P uptake ($r = 0.81$). The resin P and bicarbonate Po fractions (Table 7) accounted for 49.6 and 43.4% of the variation in maize grain yields, respectively.

Table 5. Sequentially extracted soil P pools at 45 days after planting in 2002 as affected by tithonia and inorganic P fertilizers.

Treatment	RP (mg kg ⁻¹)	Bic-Pi (mg kg ⁻¹)	Bic-Po (mg kg ⁻¹)	NaOH-Pi (mg kg ⁻¹)	NaOH-Po (mg kg ⁻¹)	HCl-Pi (mg kg ⁻¹)
Control	2.6 k	6.7 e	10.4 e	51 h	139 bc	1.6 gh
Tithonia 2.5 t ha ⁻¹ (T2.5)	5.1 j	8.4 e	12.3 cd	55 gh	143 abc	1.1 h
Tithonia 5.0 t ha ⁻¹ (T5)	5.7 j	7.9 e	12.5 cd	59 g	131 c	1.4 h
Tithonia 7.5 t ha ⁻¹ (T7.5)	8.0 i	12.6 d	11.7d	69 f	136 bc	2.0 fg
MPR 80 kg P ha ⁻¹	48.7 b	33.6 b	9.9 e	100 b	145 abc	11.1 a
TSP 80 kg P ha ⁻¹	37.8 c	41.3 a	10.6 e	118 a	160 a	5.4 b
MPR 40 + T2.5	21.1 h	20.5 c	13.3 bc	93 c	133 bc	3.3 d
MPR 40 + T5	23.2 g	18.5 c	13.9 b	81 e	145 abc	2.9 de
MPR 40 + T7	31.6 e	14.1 d	15.4 a	87 d	150 ab	2.4 ef
TSP 40 + T2.5	28.9 f	32.9 b	15.3 a	95 c	148 abc	3.1 d
TSP 40 + T5	36.0 d	41.5 a	15.2 a	85 de	140 bc	4.5 c
TSP 40 + T7.5	58.4 a	34.8 b	15.4 a	84 de	149 ab	4.5 c
CV (%)	3.53	6.07	4.56	3.74	6.37	7.85

RP = Resin P; Bic-Pi and NaOH-Pi = inorganic extractable P; Bic-Po and NaOH-Po = organic extractable P.

Table 6. Effect of tithonia when applied alone or combined with MPR or TSP on maize yields.

Treatments	MGY t ha ⁻¹	
	2001	2002
Control (-P)	1.34 f	0.87 e
Tithonia 2.5tha ⁻¹ (T2)	2.10 bcde	1.50 d
Tithonia 5 tha ⁻¹ (T5)	2.33 abc	1.69 cd
Tithonia 7.5tha ⁻¹ (T7)	2.29 abcd	2.06 bcd
MPR (P 80)	1.87 e	2.21 abc
TSP (P 80)	2.50 a	1.81 cd
MPR (P 40) + T2	2.36 ab	2.30 abc
MPR (P 40) + T5	2.34 abc	2.31 abc
MPR (P 40) + T7	2.36 ab	2.74 a
TSP (P 40) + T2	2.07 cde	2.50 ab
TSP (P 40) + T5	2.29 abcd	2.72 a
TSP (P 40) + T7	2.48 a	2.84 a
CV (%)	7.62	15.69

Means followed by the same letter in the same column are not significantly different $P < 0.05$ according to DMRT; MGY = Maize grain yield.

Phosphorus and Ca uptake by the maize plants at tasselling

Tithonia significantly ($P \leq 0.0001$) increased P uptake in both shoots and roots, as well as concentrations in leaves, over those in the control (Table 8). Similarly combining tithonia with MPR increased shoot and root P compared to that in the control treatment. The increases in shoot P for the highest level of tithonia + MPR was higher than that of tithonia alone.

The trend for P uptake was similar when tithonia was combined with TSP. The Ca uptake in both shoots and roots followed a similar pattern as P uptake.

Discussion

Characteristics of the soil and organic material used

The experimental site had low soil pH, P and Ca, which are conducive for increased MPR dissolution (Mnkeni et al. 1991). Dissolution of any phosphate rock is enhanced by low pH, Ca and P (Rajan et al. 1996; Szilas 2002) because such a situation provides protons and Ca and P sinks. The high green manure quality of tithonia (as depicted by high N, P, low lignin and polyphenol contents, narrow C:N ratio) ensures rapid decomposition and net N and P mineralization

(Palm et al. 2001). The high N, P and K concentrations of tithonia (Table 3) make it a good source for plant nutrients on this Chromic Acrisol (Gachengo et al. 1999; Nziguheba et al. 2000). The high basic cation concentrations of tithonia green manure (Table 3) makes it a fairly good acidity ameliorating amendment on this Chromic Acrisol (George et al. 2002).

Effects of the treatments on soil properties

The increase in soil pH due to tithonia and MPR can be attributed to the large Ca concentration of tithonia (Table 3) and MPR (Table 2). These results are consistent with the work of Phan Thi Cong (2000) and George et al. (2002) who reported increase in pH on similar soils due to tithonia application in Vietnam and Kenya, respectively. Displacement of hydroxyls from sesquioxide surfaces by organic anions can also be a cause for increase in pH (Parffit 1978). Ikerra (2004) found that tithonia contained relatively high concentrations of organic acids like oxalic and tartaric, and these could have participated in such reactions. The same reason explains why there was increase in exchangeable Ca for the same treatments. Since the soil under study was Ca deficient (Table 1), application of tithonia and MPR improved the supply and availability of Ca to crops as depicted by increased concentrations and uptake by maize (Table 8). However, when tithonia is combined with MPR, and depending on the Ca gradient created by plant uptake, it can decrease MPR dissolution because of the common ion effect (Rajan et al. 1996; Savini 2000; Ikerra et al. 2001b). Reduction of exchangeable Al by tithonia and MPR was caused by the increase in soil pH and exchangeable Ca (Table 4). Some of the exchangeable Al could have been complexed by Ca or chelated by organic ligands produced during decomposition of tithonia (Ikerra 2004). Decrease in pH due to TSP application is attributed to the production of phosphoric acid during its hydrolysis and its low pH (Table 2).

The decrease in exchangeable Al accompanied by increase in pH and Ca, has a positive effect of reducing P sorption (Sanyal and De Datta 1991). This was revealed by a decrease in the P sorption index due to application of tithonia either alone or combined with MPR or TSP (Table 4). The

Table 7. Linear regressions of maize yields in 2002 (Y) on different P pools.

P Pool	R ²	Probability	Equation
Resin P	0.4963	***	$Y = 0.023 \text{ RP} + 1.53$
Bic-Pi	0.2687	**	$Y = 0.025 \text{ Bic-Pi} + 1.55$
Bic-Po	0.4339	***	$Y = 0.202 \text{ Bic-Po} - 0.49$
NaOH-Pi	0.2210	**	$Y = 0.015 \text{ NaOH-Pi} + 0.88$
NaOH-Po	0.0038	ns	$Y = 0.010 \text{ NaOH-Po} + 0.59$
HCl-P	0.0690	ns	$Y = 0.063 \text{ HCl-P} + 1.90$

Decrease in P sorption capacity, as reflected by the P-adsorption maximum and PSI, could be due to (1) increase in soil pH which results in precipitation of exchangeable Al and Fe, (2) competitive adsorption of organic ligands on P sorption sites (Hue 1991; Ikerra 2004), (3) chelation of Fe and Al by organic ligands, which releases the fixed P (Ikerra 2004), (4) addition of P from organic material decomposition (Singh and Jones 1976), and (5) addition of inorganic P from MPR dissolution (Ikerra et al. 1994, 2001b). Decrease in P sorption reduces the P buffer capacity and hence decreases MPR dissolution (Wright et al. 1992). The positive interactive effects observed by combining MPR with tithonia should, therefore, be the result of improved P availability rather than enhanced MPR dissolution because Ca, P and proton affinity were all increased following tithonia application (Ikerra et al. 2001b).

P pools

The significant increase in both labile and moderately labile P obtained through application of MPR alone (Table 5) implies that MPR underwent considerable dissolution. The substantial MPR dissolution could be attributed to the low pH, Ca and P contents of this soil (Ikerra et al. 1994). Most of the P released from inorganic fertilizers was extracted in the NaOH-Pi and NaOH-Po fractions. Since these fractions are associated with Al and Fe, this indicates that there was rapid adsorption of the P in soil solution through chemisorption by Al and Fe. Tithonia at all rates increased resin P compared to that in the control due to the high concentrations of P in tithonia and its depressing effect on P sorption. Tithonia GM at all rates produced significantly more bicarbonate extractable organic P than did inorganic fertilizers, and this may contribute to a better residual P effect in plots that received the GM (Gachengo et al. 1999). The lack of significant differences between Gm treated plots and controls in the NaOH-Po fraction indicates that the soil has a good reserve of chemisorbed organic P that can be available through management strategies that reduce P fixation. This P fraction has been reported to be an important P source in unfertilized systems (Beck and Sanchez 1994). More P was found in the HCl-Pi fraction (Ca-P) in treatments with MPR than in

Table 8. Influence of tithonia applied alone or co-applied with MPR or TSP on shoot and root Ca and P uptake at tasselling of maize in the field experiment in 2002.

Treatment	Shoot P and Ca uptake (kg ha ⁻¹)		Roots P and Ca uptake (kg ha ⁻¹)		Leaf P and Ca conc. (%)	
	P	Ca	P	Ca	P	Ca
Control (-P)	1.25 h	1.77 g	0.04 g	0.09 e	0.22 d	0.14 d
Tithonia2.5tha ⁻¹ (T2)	2.63 fg	2.36 ef	0.07 f	0.14 cd	0.27 abc	0.19 abc
Tithonia5tha ⁻¹ (T5)	2.45 g	2.62 de	0.08 f	0.13 d	0.28 abc	0.20 ab
Tithonia7.5tha ⁻¹ (T7)	2.70 fg	2.63 de	0.16 d	0.20 b	0.28 abc	0.21 a
MPR (P 80)	3.02 ef	3.38 bc	0.15 d	0.24 a	0.29 a	0.19 abc
TSP (P 80)	4.14 bc	2.53 ef	0.14 de	0.14 cd	0.25 bc	0.18 bc
MPR (P 40) + T2	3.91 cd	1.92 fg	0.14 de	0.15 c	0.28 abc	0.16 cd
MPR (P 40) + T5	4.39 bc	3.26 bcd	0.15 de	0.16 c	0.29 ab	0.18 bc
MPR (P 40) + T7	4.62 b	4.41 a	0.19 c	0.15 c	0.28 abc	0.18 bc
TSP (P 40) + T2	3.50 de	2.84 cde	0.13 e	0.08 e	0.25 cd	0.18 bc
TSP (P 40) + T5	4.45 b	3.85 ab	0.22 b	0.13 d	0.28 ab	0.17 bc
TSP (P 40) + T7	5.76 a	4.35 a	0.25 a	0.24 a	0.28 ab	0.18 bc
CV (%)	7.97	13.35	7.02	7.52	6.77	9.18

Means followed by the same letter in the same column are not significantly different $P < 0.05$ according to DMRT.

those with TSP, revealing that unlike TSP which dissolves instantaneously, MPR dissolution is a slow process, and in this case part of it was still undissolved and hence more residual effects could be expected in subsequent years from MPR than from TSP. This makes MPR an agronomically better P source on this Chromic Acrisol than TSP.

Maize grain yields

Maize grain yields were increased by tithonia in both years (Table 6). This reflects the corresponding increase in resin P (Table 5) and improvement in soil chemical properties that enhance P availability. It was further revealed by the remarkable positive correlation between resin P and maize grain yields. Both P and Ca uptake by the shoots and roots were increased following GM application because uptake is a product of yield and concentration. Combining tithonia with MPR at half the recommended rate (40 kg P ha⁻¹) in 2002 gave higher yields than using tithonia alone and this was probably due to the increased resin P and improvements in other soil parameters. The lower relative agronomic effectiveness for MPR in the first year of application was due to its slow dissolution (Szilas 2002).

Conclusions

Application of tithonia to this soil resulted in improvement in soil chemical properties related to P availability (i.e. pH, Ca, Al) and reduced P sorption as reflected by the P max and PSI. Combining tithonia GM at 5 Mg ha⁻¹ with MPR at half the recommended rate of 40 kg P ha⁻¹ further improved these soil chemical properties and consequently maize grain yields. The positive interactive effects on resin P cannot be attributed to enhancement in MPR dissolution by tithonia but rather to improvement in P availability because tithonia increased soil pH and exchangeable Ca, and reduced exchangeable Al. Where tithonia is easily obtained within farmer's fields it could be used in conjunction with MPR at half the recommended rate of P for increasing maize yields. This would be a cheaper option than supplying P from either MPR or TSP alone at the recommended rate of 80 kg P ha⁻¹. Transfer of tithonia from

off-farm might be expensive since large amounts of fresh tithonia are needed to obtain moderate maize yields of 2 Mg ha⁻¹. Hence, integrating lower rates of tithonia with MPR could be a viable option for improving soil chemical and physical properties and consequently maize grain yields on this Chromic Acrisol in Morogoro, Tanzania.

Acknowledgements

We would like to thank the Tanzania TARP-II World Bank Research Program for funding this research. Partial financial support from ICRAF under the ANAFE fellowship program and the Rockefeller Foundation are highly acknowledged. The first author would like to thank the Ministry of Agriculture and Food Security, Tanzania, for granting her a study leave. Assistance by the laboratory staff of the Department of Soil Science at SUA, TSBF and at ICRAF is gratefully appreciated.

References

- Anderson G.D. 1965. Estimation of potential productivity of some pastures in Mbuluhighlands (Tanganyika) by application of fertilizers. *E.A Agric. For. J.* 30: 206–217.
- Anderson J.M. and Ingram J.S.I. 1993. *Tropical Soil Biology and Fertility. A Handbook of Methods*, 2nd ed. CAB International, Wallingford, UK.
- Beck M.A. and Sanchez P.A. 1994. Soil phosphorus fraction dynamics during 18 years of cultivation on a Typic Paleudult. *Soil Sci. Soc. Am. J.* 58: 1424–143.
- Bremner J.M. and Mulvaney C.S. 1982. Nitrogen total. In: Page A.L. (ed.), *Methods of Soil Analysis*, Part 2. Soil Science Society of America, Madison, Wisconsin, USA, pp. 595–624.
- De Pauw 1984. *Soils, Physiography and Agroecological zones of Tanzania. A Consultant Report*. Ministry of Agriculture, Dar es Salaam, Tanzania FAO, Rome Italy, 163 pp.
- Dorich R.A. and Nelson D.W. 1984. Evaluation of manual cadmium reduction methods for determination of nitrate in potassium chloride extracts of soil. *Soil Sci. Soc. Am. J.* 48: 72–75.
- Easterwood G.W. and Sartain J.B. 1990. Clover residue effectiveness in reducing orthophosphate sorption on ferric hydroxide coated soil. *Soil Sci. Soc. Am. J.* 54: 1345–1350.
- Fox R.L. and Kamprath E.J. 1970. Phosphate sorption isotherms for evaluating the phosphate requirement of soil. *Soil Sci. Soc. Am. Proc.* 34: 902–907.
- Gachengo C.N., Palm C.A., Jama B. and Othieno C. 1999. Combined use of trees, shrubs and inorganic fertilizers for soil fertility management. *Agrofor. Syst.* 44: 21–36.
- Gee G.W. and Bauder J.W. 1986. Particle size analysis. In: Klute A. (ed.), *Methods of Soil Analysis*, Part 1. Physical and

- Mineralogical Methods, Agronomy No. 9, 2nd ed. America Society of Agronomy, Inc., Madison, Wisconsin, USA, pp. 383–412.
- George T.S., Gregory P.J., Robinson J.S., Buresh R.J. and Jama B. 2002. Utilization of soil organic phosphorus by agroforestry and crop species in the field in western Kenya. *Plant Soil* 246: 53–63.
- He Z.L., Baligar V.C., Martens D.C., Ritchey K.D. and Kemper W.D. 1996. Factors affecting phosphate rock dissolution in acid soil amended with liming materials and cellulose. *Soil Sci. Soc. Am. J.* 60: 596–1601.
- Hossner L.R. 1996. Dissolution of total elemental analysis. In: Sparks D.L. (ed.), *Methods of Soil Analysis, Part 3. Chemical Methods*. Soil Science Society of America, American Society of Agronomy, Madison, Wisconsin, USA, pp. 57–58.
- Hue N.V. 1991. Effects of organic acids/anions on P sorption and phytoavailability in soils with different mineralogies. *Soil Sci.* 152: 463–471.
- Ikerra S.T. 2004. Use of Minjingu phosphate rock combined with different organic inputs in improving phosphorus availability and maize yields on a Chromic Acrisol in Morogoro, Tanzania, Ph.D Thesis. Sokoine University of Agriculture, Morogoro, Tanzania.
- Ikerra S.T. and Kalumuna M.C. 1992. Phosphorus adsorption characteristics of soils and their influence on maize yields to P application along Mlingano catena, Tanga, Tanzania. In: Zake J.Y.K. et al. (eds), *Proceedings of the 11th AGM of the SSSEA, Mukono Kampala*. Dec. 1991, pp. 85–94.
- Ikerra S.T., Maghembe A.J., Smithson P.C. and Buresh R.J. 1999. Soil nitrogen dynamics and relationships with maize yields in a gliricidia–maize intercrop in Malawi. *Plant Soil* 211: 155–164.
- Ikerra S.T., Maghembe A.J., Smithson P.C. and Buresh R.J. 2001a. Dry season sesbania fallows and their influence on nitrogen availability and maize yields in Malawi. *Agrofor. Syst.* 52: 13–21.
- Ikerra S.T., Mrema J.P., Semu E. and Smithson P.C. 2001b. Effect of organic materials on MPR dissolution on an Ultisol in Morogoro, Tanzania. Paper Presented at the 19th AGM of the SSSEA, Moshi, Tanzania, Dec. 2001.
- Ikerra T.W.D., Mnkeni P.N.S. and Singh R. 1994. Effects of added compost and farmyard manure on P release from Minjingu phosphate rock and its uptake by maize. *Norwegian J. Agric. Sci.* 8: 13–23.
- Iyamuremye F., Dick R.P. and Baham J. 1996. Organic amendments and phosphorus sorption by soils. *Adv. Agron.* 56: 139–185.
- Lindsay W. and Norvell W.A. 1978. Development of DTPA Soil test for zinc, iron, manganese and copper. *Soil Sci. Soc. Am. J.* 42: 421–428.
- Landon J.R. 1991. *Booker Tropical Soil Manual. A Handbook for Soil Survey and Agricultural and Land Evaluation in the Tropics and Subtropics*. Longman, London.
- Loeppert R.H. and Suarez D.L. 1996. Carbonate and gypsum. In: Sparks D.L. (ed.), *Methods of Soil Analysis, Chemical Methods*, Soil Science Society of America, American Society of Agronomy, Madison, Wisconsin, USA, pp. 437–474.
- McLean E.O. 1965. Soil pH and lime requirement. In: Black C.A. et al. (eds), *Methods of Soil Analysis, Part 2. Agronomy 9*, American Society of Agronomy, Madison, Wisconsin, pp. 199–223.
- McClellan G.H. and Gremillion L.R. 1980. Evaluation of phosphate raw materials. In: Khasawneh F.E. et al. (eds), *The Role of Phosphorus in Agriculture*, Soil Science Society of America, Madison, USA, pp. 43–80.
- Mnkeni P.N.S., Semoka J.M.R. and Buganga J.B. 1991. Agronomic effectiveness of Minjingu phosphate rock as a source of phosphorus for maize in four soils of Morogoro district, Tanzania. *Zimbabwe J. Agric. Res.* 30(1): 27–37.
- Mnkeni P.N.S., Semoka J.M.R. and Kaitaba E.G. 1994. Effect of Mopogoro philipsite on the availability of phosphorus in phosphate rocks. *Trop. Agric. Trin.* 71(4): 249–253.
- Mowo J.G. 2000. Effectiveness of phosphate rock on Ferral soils in Tanzania and the influence of within field variability, Ph.D Thesis. Wageningen Agricultural University, The Netherlands, 164 pp.
- Murphy J. and Riley J.P. 1962. A modified single solution method for the determination of phosphate in natural waters. *Anal. Chim. Acta* 27: 31–36.
- Ngatunga E.L. and Deckers, J. 1984. Preliminary results of long term experiment comparing the effects of rock phosphate and triple super phosphate on the yield of maize and sorghum at Naliende Mtwaru, Tanzania, Presented at the 6th AGM of the SSSEA.
- Nziguheba G., Merckx R., Palm C.A. and Mutuo P. 2002. Combining *Tithonia diversifolia* and fertilizers for maize production in phosphorus deficient soil in Kenya. *Agrofor. Syst.* 55: 165–174.
- Nziguheba G., Merckx R., Palm C.A. and Rao M. 2000. Organic residues affect phosphorus availability and maize yields in a Nitisol of western Kenya. *Biol. Fertil. Soils* 32: 328–339.
- Okalebo J.R., Gathua K.W. and Woome P.L. 2002. Laboratory methods of soil and plant analysis. A working manual. KARI, SSSEA, TSBF, UNESCO-ROSTA, Nairobi, 88 pp.
- Palm C.A., Myers R.J.K. and Nandwa S.M. 1997. Combined use of organic and inorganic nutrient sources for soil fertility replenishment. In: Buresh R. (ed.), *Replenishing Soil Fertility in Africa*. SSSA Special Publication Number 51, SSSA, USA, pp. 193–217.
- Palm C.A., Gachengo C.N., Delve R.J., Cadisch G. and Giller K.E. 2001. Organic inputs for soil fertility management in tropical agroecosystems: application of an organic resource database. *Agric. Ecosyst. Environ.* 83: 27–42.
- Phan Thi Cong 2000. Improving phosphorus availability in selected soils from the uplands of south Vietnam by residue management. A case study: *Tithonia diversifolia*, Ph.D Thesis No. 439. Katholieke University Leuven, Belgium.
- Parffit R.L. 1978. Anion adsorption by soils and soil materials. *Adv. Agron.* 30: 26–34.
- Rajan S.S.S., Watkinson J.K. and Sinclair A.G. 1996. Phosphate rocks for direct application to soils. *Adv. Agron.* 53: 77–159.
- Reddy K.R., Overcash M.R., Khaleel P. and Westerman P.W. 1980. Phosphorus adsorption desorption of two soils utilized for disposal of animal waste. *J. Environ. Qual.* 9: 86–92.
- Rhodes J.D. 1982. Cations exchange capacity. In: Miller R.H. and Keeney P.R. (eds), *Methods of Soil Analysis, Part 2. Chemical and Microbiological Properties*, Agronomy Monographs No. 9. American Society of Agronomy, Inc., Madison, WI, pp. 149–169.
- Sanchez P.A. and Jama B.A. 2002. Soil fertility replenishment takes off in East and Southern Africa. In: Vanlauwe B. et al.

- (eds), Integrated Plant Nutrition Management in Sub-Saharan Africa from Concept to Practice. CABI International, pp. 23–45.
- Sanyal S.K. and De Datta S.K. 1991. Chemistry of phosphorus transformations in soils. *Adv. Soil Sci.* 16: 31–60.
- SAS Institute 1995. SAS User's guide, 6th ed. SAS Institute, Cary, N.C.
- Savini I. 2000. The effect of organic and inorganic amendments on phosphorous release and availability from two phosphate rocks and triple super phosphate in phosphorous fixing soils, MSc Thesis. University of Nairobi, Kenya, 104 pp.
- Sibbesen E. 1978. An investigation of anion exchange resin method for soil phosphate extraction. *Plant Soil* 50: 305–321.
- Soil Survey Staff 1975. *Soil Taxonomy*. United States Department of Agriculture, McGraw Hill Book Co., Inc., New York.
- Smaling E.M.A., Stoorvogel J.J. and Windmeijer P.N. 1993. Calculating soil nutrient balances in Africa at different scales. 11. District scale. *Fert. Res.* 35: 237–250.
- Singh B.R., Uriyo A.P., Mkeni P.N.S. and Msaky J.J. 1977. Evaluation of indices of N and P availability for soil of Morogoro, Tanzania. *Proceedings of the Conference on Classification of Tropical Soils*, Kuala Lumpur, Malaysia, pp. 273–278.
- Singh B.B. and Jones J.P. 1976. Phosphorus sorption and desorption characteristics of soil as affected by organic residues. *Soil Sci. Soc. Am. J.* 40: 38–394.
- Szilas C. 2002. The Tanzanian Minjingu phosphate rock - Possibilities and limitations for direct application. Ph.D. Thesis. Royal Veterinary and Agricultural University, Copenhagen, Denmark, 175 pp.
- Tiessen H. and Moir J.O. 1993. Characterization of available phosphorus by sequential extraction. In: Carter M.R. (ed.), *Soil Sampling and Methods of Analysis*. Lewis, Ann Arbor, Michigan, USA.
- Tisdale S.L., Nelson W.L., Beaton J.D. and Havlin L. 1993. *Soil fertility and Fertilizers*, 5th ed. Prentice-Hall, Inc., New Jersey, 634 pp.
- Van Straaten P. 2000. Poverty reduction in sub-Saharan Africa. Geological resources for sustainable crop production. Report for United Nations Revolving Fund for Natural Resources Exploration, University of Guelph, Canada, May 2000, 274 pp.
- Warren G.P. 1992. Fertilizer Phosphorus Sorption and Residue Value in Tropical African Soils. NRI, Bulletin 37. Natural Resource Institute, Chatham, England.
- Wright R.J., Baligar V.C. and Belesky D.P. 1992. Dissolution of North Carolina phosphate rock in soils of the Appalachian Region. *Soil Sci.* 153: 25–36.
- WRB 1998. World Reference Base for Soil Resources. World Soil Resources Report 84. FAO ISRIC, ISSS, Rome, Italy.

Improving food production using ‘best bet’ soil fertility technologies in the Central highlands of Kenya

Daniel Mugendi¹, Monicah Mucheru-Muna¹, Jayne Mugwe², James Kung'u¹ and Andre Bationo³

¹Kenyatta University, Department of Environmental Sciences, P. O. Box 43844, Nairobi, Kenya Email: dmugendi@yahoo.com; moniquechiku@yahoo.com; kungu-j@yahoo.com; ²Kenya Forestry Research Institute, P. O. Box 20412, Nairobi, Kenya Email: jaynemugwe@yahoo.com; ³Tropical Soil Biology and Fertility (TSBF) Institute of CIAT, P. O. Box 30677 Nairobi, Kenya Email: abationo@cgiar.org

Abstract

Declining crop productivity is a major challenge facing smallholder farmers in central highlands of Kenya. This decline is caused by continuous cultivation of soils without adequate addition of external inputs in form of manures and fertilizers. With this background, an on-station trial was initiated at Embu in 1992 to evaluate the feasibility of using two leguminous shrubs; *Calliandra calothyrsus* and *Leucaena leucocephala* for improving food production. In 2000, an off-station farmers' participatory trial aimed at offering farmers soil enhancing technologies for replenishing soil fertility was established in Meru South District. The results from the Embu on-station trial indicate that, over the 11 years of study, calliandra and leucaena biomass transfer with half recommended rate of inorganic fertilizer treatments gave the best average maize grain yields of 3.3 Mg ha⁻¹. Treatment where calliandra was alley cropped with maize but the prunings removed recorded the lowest maize yield of 1.2 Mg ha⁻¹. Treatments with calliandra and leucaena biomass transfer had similar yields but treatments that were alley cropped with leucaena did better than those that were alley cropped with calliandra. On the other hand, results from the off-station trial in Meru South indicate that, on average, across the seven seasons, sole tithonia gave the highest maize grain yield followed closely by tithonia with half recommended rate of inorganic fertilizer with 6.4 and 6.3 Mg ha⁻¹ respectively. Control gave the lowest yield of 2.2 Mg ha⁻¹ across the seasons. On average, integration of organic and inorganic sources of nutrients gave higher yields compared to all the other treatments.

Key words: Leucaena, Calliandra, Herbaceous legumes, Tithonia, Farmers, Cattle manure

Introduction

The Central highlands of Kenya are densely populated with more than 700 persons km⁻² (Government of Kenya, 2001) and declining land productivity with reduced crop yields has been a major challenge facing smallholder farmers in the region. Declining land productivity is as a result of soil impoverishment caused by continuous cropping without addition of adequate external inputs, and soil erosion on steep slopes (Minae and Nyamai, 1988). Land sizes are small, averaging 1.2

ha, leading to continuous cropping with limited scope for crop rotation and inadequate soil fertility replenishment. For instance, the use of inorganic fertilizers is as low as less than 20 kg N and 10 kg P ha⁻¹ (Murithi et al., 1994). The amount is inadequate (below the recommended level of 60 kg N ha⁻¹), to meet the crop nutrient requirement for optimum crop productivity in the area. Kihanda (1996) observed that less than 25% maize growers in the central highlands of Kenya use inorganic fertilizers. Wokabi (1994) reported that, though high yielding maize varieties have been developed with

yield potentials of 7–12 Mg ha⁻¹, maize yields at the farm level hardly exceed 1.5 Mg ha⁻¹.

Research work by Gachengo (1996), Kihanda (1996), Gitari et al. (1997), Mugendi et al. (1999), Mutuo et al. (2000) and Nziguheba and Mutuo (2000) reported positive results from use of biomass from mucuna, crotalaria, manure, tithonia, calliandra and leucaena for soil fertility improvement in Kenyan highlands. These organic inputs are important components in soil fertility replenishment and hence need to be evaluated on-farm by farmers. An on-station trial was established in Embu in 1992 to evaluate the performance of calliandra and leucaena on soil fertility replenishment. In 2000 a multidisciplinary participatory trial was established in Meru South District to bring feasible soil nutrient replenishment technologies to the smallholder resource poor farmers.

Materials and methods

Study area

The on-station trial was located at the Kenya Agricultural Research Institute Regional Centre (Embu), in the central highlands of Kenya. The site is characterized by a bimodal rainfall distribution, which ranges from 1200 mm to 1500 mm per annum. The soils are commonly known as “Kikuyu Red Clay Loams”. They are extremely deep (> 2m), well drained, with moderate structure (Mwangi, 1997). They are derived from rich, basic volcanic rocks and have been classified as Humic Nitisols (Jaetzold and Schmidt, 1983).

The off-station trial was conducted in Meru South District, an area classified as upper midlands 2 and 3 (UM2 and UM3) according to Jaetzold and Schimdt (1983) with an altitude of approximately 1500 m above sea level. The annual mean temperature is 20°C and annual rainfall varies from 1200 to 1500 mm. The soils are Humic Nitisols (Jaetzold and Schmidt, 1983), which are deep, well weathered with moderate to high inherent fertility. The rainfall is bimodal, falling in two seasons, the long rains (LR) lasting from March through June and short rains (SR) from October through December.

Experimental layout

The on-station experiment was initiated in 1992 at the Embu Regional Research Centre as a randomized

Improvement using ‘best bet’ soil fertility technologies

complete block design with four replicates. The plot dimensions were 9 × 10 m while the sample plot was 6 × 4.5 m. The test crop was maize (*Zea mays* L, var. H511). In six of these treatments fresh leaf prunings of tree species (*Leucaena leucocephala* and *Calliandra calothyrsus*) were applied, the prunings being obtained from hedgerows grown in situ (alley-cropped) or ex-situ (cut and carry) from other sources. The treatment structure was as follows;

- 1) Calliandra alley crop; prunings incorporated
- 2) Leucaena alley crop; prunings incorporated
- 3) Calliandra alley crop; prunings not incorporated
- 4) Leucaena alley crop; prunings not incorporated
- 5) Calliandra prunings + no fertilizer
- 6) Leucaena prunings + no fertilizer
- 7) Calliandra prunings + fertilizer (25 kg N ha⁻¹)
- 8) Leucaena prunings + fertilizer (25 kg N ha⁻¹)
- 9) With fertilizer (50 kg N ha⁻¹)
- 10) Without fertilizer

Lopping of calliandra and leucaena tree hedges was done at a height of 50 cm one to two days before maize planting. Leafy biomass and succulent stems were separated from woody stems and each weighed separately. The leafy biomass was evenly spread on the ground in the treatments designated to receive prunings (Treatment 1, 2, 5, 6, 7, and 8) and soil-incorporated by hand hoes as the land was prepared for maize planting. Sub-samples were collected for N content determination before the prunings were incorporated into the soil. Leafy biomass applied in treatments 7 and 8 (that received prunings from outside the experimental plots-biomass transfer) were obtained from block plantings of calliandra and leucaena hedges established near the site. These treatments received average biomass (dry matter basis) of 2 and 1 Mg ha⁻¹ for calliandra and leucaena biomass containing approximately 60 and 30 kg N ha⁻¹ season⁻¹ respectively. Treatment 9 received the recommended level of inorganic fertilizer of 50 kg N ha⁻¹ (FURP, 1987) as calcium ammonium nitrate while treatments 7 & 8 received half of the recommended rate (30 kg N ha⁻¹) (to approximate the lower levels commonly applied by most farmers in the area). Application was through top dressing in two doses; the first dose (one-third of the full dose) four weeks after maize germination and the second (two-thirds), four weeks later.

The off-station trial was established in March 2000 in Meru South on a farm with poor and impoverished soils and laid out as a randomised complete block design

Table 1. Soil fertility replenishment technologies under experimentation in Meru south District, Kenya.

No	Treatment	Amount of N supplied (kg ha ⁻¹)	
		Organic	Inorganic
1	Mucuna pruriens alone	–	–
2	Mucuna + 30 kg N ha ⁻¹	–	30
3	Crotalaria ochroleuca alone	–	–
4	Crotalaria + 30 kg N ha ⁻¹	–	30
5	Cattle manure	60	–
6	Cattle manure + 30 kg N ha ⁻¹	30	30
7	Tithonia diversifolia	60	–
8	Tithonia + 30 kg N ha ⁻¹	30	30
9	Calliandra calothyrsus	60	–
10	Calliandra + 30 kg N ha ⁻¹	30	30
11	Leucaena trichandra	60	–
12	Leucaena + 30 kg N ha ⁻¹	30	30
13	Recommended rate of fertilizer	–	60
14	Control (No inputs)	–	–

(RCBD) with three replicates. The trial was researcher-designed and managed, and the test crop was maize (*Zea mays* L, var. H513). Thirteen external soil fertility amendment inputs (technologies) were applied to give an equivalent amount of 60 kg N ha⁻¹ except for the herbaceous legume treatments where the N quantity was determined by the amount of biomass harvested and incorporated in the respective treatments (Table 1). The fourteenth technology was the absolute control.

The herbaceous legumes were intercropped between two maize rows one week after planting maize. The legumes were left in the field after harvesting the maize until the start of the following season when they were cut, weighed, chopped and applied into the soil. The other organic materials (biomass transfer) were incorporated into the soil to a depth of 15 cm during land preparation. Compound fertilizer (23:23:0) was the source of N and was applied during sowing. Agronomic procedures for maize production were appropriately followed during all the seasons. At harvesting maize grain yield was determined.

Farmers' field days were held at the grain filling stage during each season where the farmers toured the experimental plots. The technologies used were described and farmers evaluated the various technologies and exchanged views about the different technologies. The farmers were then requested to select the technologies they wanted to take to their farms. Eventually, starting with the SR 2001, farmers started trying out some of the promising technologies in their own farms. The farmers

applied the organic inputs as explained during the field days though some of them adapted the technologies to fit their socio-economic status. During harvesting, at the end of each growing season, maize grain yields and moisture content were determined.

All data on maize grain yields was subjected to analysis of variance (ANOVA) using Genstat and the means separated using LSD at 5% probability level.

Results and discussions

On-station trial (maize grain yield)

The average maize grain yields obtained in the on-station trial at Embu indicated that maize monocrop with prunings + 30 Kg N ha⁻¹ gave the highest yields of 3.3 Mg ha⁻¹ followed by maize monocrop + prunings, which gave 2.9 Mg ha⁻¹ (Table 2). Calliandra with prunings removed gave the lowest yields (1.2 Mg ha⁻¹) followed by leucaena with prunings removed and control with 1.8 and 1.7 Mg ha⁻¹ respectively. Leucaena alley cropped treatment with prunings incorporated (Treatment 2) gave better yields (2.8 Mg ha⁻¹) than the recommended fertilizer treatment (2.5 Mg ha⁻¹), whereas the equivalent calliandra treatment (Treatment 1) performed poorer than the fertilizer treatment by recording an average yield of 2.1 Mg ha⁻¹. It was further observed that all leucaena alley cropped treatments (with or without prunings incorporated) produced higher maize yields compared to similar calliandra alley cropped treatments.

These results concur with findings of Mafongoya and Nair (1997) and Mugendi et al. (1999) who reported significant maize yield increases following application of green manure. The leafy prunings incorporated into the soil (as green manure) at the beginning of the season decomposed and released nutrients especially nitrogen, which enhanced crop performance (Mugendi et al., 1999).

Treatments with prunings incorporated with fertilizer gave better maize grain yields compared to treatments with only prunings applied. This could be due to improved synchrony between nutrient release and uptake (Sanchez and Jama, 2002). Kapkiyai et al. (1998) reported that combination of organic and inorganic nutrient sources has been shown to result into synergy and improved synchronization of nutrient release and uptake by plants (leading to higher yields). Tian et al. (1993) reported that nutrient uptake and grain yield of the crop was higher when nitrogen was partially

Table 2. Mean maize grain yield (Mg ha⁻¹) from 1993 – 2003 seasons from various treatments at Embu, Kenya.

TRT	LR 93	SR 93	LR 94	SR 94	LR 95	SR 95	LR 96	LR 97	SR 97	LR 98	SR 98	SR 99	SR 00	SR 01	LR 02	SR 02	LR 03	SR 03	Mean
1	2.4	0.1	0.3	3.2	3.4	2.4	2.0	2.3	4.3	2.7	0.7	2.7	2.5	1.5	0.8	1.8	2.7	2.9	2.2
2	2.2	0.2	0.2	3.8	4.4	3.9	3.6	3.1	5.0	3.8	0.6	3.9	4.2	2.5	1.3	1.9	2.6	4.1	2.9
3	1.7	0.1	0.4	1.6	1.1	1.0	1.3	1.9	3.6	1.3	0.5	1.3	1.4	1.0	0.2	0.9	1.4	1.4	1.2
4	1.5	0.2	0.5	2.7	1.8	1.7	1.5	1.7	4.6	2.2	0.7	2.0	1.7	2.6	0.4	1.7	1.9	2.3	1.8
5	1.9	0.6	0.3	3.6	4.0	4.9	3.8	3.0	4.0	2.8	1.0	3.8	3.9	3.2	1.9	3.8	2.6	3.6	2.9
6	1.6	0.3	0.9	3.3	4.2	4.7	3.9	2.5	7.1	2.7	1.2	3.1	3.5	2.9	1.4	2.8	2.9	3.2	2.9
7	2.1	0.7	2.1	3.6	2.2	5.6	4.2	2.2	7.9	3.4	0.9	3.9	4.3	3.2	1.9	3.5	3.4	4.9	3.3
8	1.8	0.3	2.5	3.2	3.1	5.0	4.0	1.8	7.5	2.6	1.1	4.4	4.6	3.3	1.9	3.6	3.2	4.6	3.3
9	1.6	0.3	3.0	3.1	3.1	3.5	3.6	2.0	4.1	2.9	0.7	2.8	2.1	2.5	1.6	2.1	2.1	4.3	2.5
10	1.4	0.2	1.1	3.0	2.8	2.0	1.8	1.9	1.8	2.3	0.6	2.4	2.2	1.8	0.8	1.6	1.5	2.2	1.7
SED	0.8	0.1	0.2	0.6	0.5	0.4	0.2	0.4	0.2	0.3	0.2	0.4	0.8	0.5	0.7	0.9	0.6	0.5	0.2

Abbreviations: SR = Short rains; LR = Long rains; TRT = Treatments; TRT 1 = Calliandra, prunings incorporated; 2 = Leucaena, prunings incorporated; 3 = Calliandra, prunings not incorporated; 4 = Leucaena, prunings not incorporated; 5 = Calliandra prunings + no fertilizer; 6 = Leucaena prunings + no fertilizer; 7 = Calliandra prunings + fertilizer (25 kg N/ha); 8 = Leucaena prunings + fertilizer (25 kg N/ha); 9 = fertilizer (50 kg N/ha); 10 = control; NB: There was a crop failure in the SR 1996, LR 1999, LR 2000 and LR 2001 seasons as a result of inadequate rainfall.

applied as prunings, indicating the importance of the combined addition of plant residue and fertilizer N for improving crop production.

Plots that received calliandra and leucaena prunings (biomass transfer), with and without fertilizer, gave identical average maize yields (Treatments 5 & 6 and 7 & 8). However, maize grain yields obtained in leucaena alley crop (with prunings incorporated or with prunings removed) treatments (Treatment 2 and 4) was significantly higher compared to calliandra alley crop (with prunings incorporated or with prunings removed) treatments (Treatment 1 and 3). This is an indication that leucaena can be used effectively in alley cropping arrangements to improve crop yields in the region (Mugendi et al., 1999; Mugwe and Mugendi, 1999). Other researchers working with calliandra have reported mixed performance. Some have reported improved crop yields (Heinneman, 1992; Rosecrance et al., 1992), while Gutteridge (1992) reported depressed or marginal yields. The poor performance of calliandra may be attributed to root morphology where root studies showed that over 95% of all maize roots were located in the top 90 cm while for calliandra and leucaena it was 60% and 25% respectively in the same depth (Mugendi et al., 2003).

Calliandra therefore competed with maize more intensely compared to leucaena whose greater percentages of roots were located below the effective rooting zone of the maize crop. Indeed, Jama et al. (1998) demonstrated that calliandra had the greatest root density in the top 15 cm of soil when compared to four other

multipurpose tree species (*Eucalyptus grandis*, *Sesbania sesban*, *Markhamia lutea*, and *Grevillea robusta*) evaluated in the western highlands of Kenya.

Off-station

Table 3 shows the average maize grain yields in the different treatments across the seven seasons from the off-station trial in Meru South. The maize grain yields were significantly different ($P < 0.05$) between treatments in the seven seasons.

Sole tithonia recorded the highest maize grain yield of 6.4 Mg ha⁻¹ followed closely by tithonia with half recommended rate of inorganic fertilizer (6.3 Mg ha⁻¹). The control recorded the lowest maize grain yields across the treatments and seasons with 2.2 Mg ha⁻¹ followed closely by sole crotalaria with 2.6 Mg ha⁻¹ (Table 2).

It was observed that in most of the seasons, the integration of organic and inorganic nutrient sources of N gave higher maize yields than all the other treatments during the seven seasons of the study. These results concur with results by Gachengo (1996), Mugendi et al. (1999), Mutuo et al. (2000) and Nziguheba and Mutuo (2000) on the integration of organic and inorganic soil fertility inputs. As noted by Vanlauwe et al. (2002), the integration of inorganic and organic nutrient inputs increases fertilizer use efficiency and provides a more balanced supply of nutrients to the crop.

Table 3. Maize yields (Mg ha^{-1}) under different technologies from 2000 to 2003 in Chuka, Meru South District, Kenya.

Treatment	Seasons							Mean
	Grain weight (Mg ha^{-1})							
	LR 2000	SR 2000	LR 2001	SR 2001	LR 2002	SR 2002	LR 2003	
1	1.3	4.0	2.4	3.7	3.2	5.1	3.0	3.2
2	0.9	2.1	1.9	1.8	3.5	4.3	4.0	2.6
3	1.4	4.4	3.2	2.7	3.8	4.8	4.3	3.5
4	1.4	3.4	2.4	3.2	4.3	5.9	4.9	3.6
5	1.2	6.7	3.7	4.6	4.2	6.1	5.0	5.3
6	1.2	6.5	4.9	2.9	5.9	5.0	6.5	5.5
7	1.2	6.6	4.3	6.5	5.4	7.0	7.4	6.4
8	0.7	6.0	2.8	4.5	4.5	7.6	6.5	5.4
9	1.0	6.1	4.0	5.8	4.7	6.3	6.4	5.7
10	1.3	6.8	5.4	5.6	5.4	6.2	7.2	6.3
11	1.1	5.8	4.3	5.1	4.3	7.2	6.2	5.7
12	1.3	6.1	3.7	4.4	5.0	7.2	6.2	5.7
13	1.4	6.3	5.0	3.2	4.3	5.8	5.5	5.3
14	0.6	2.6	1.2	1.5	1.8	2.6	2.8	2.2
LSD	0.2	0.2	0.4	0.4	0.3	0.4	0.5	0.3

Treatment (1 = Mucuna; 2 = Crotalaria; 3 = Mucuna + $\frac{1}{2}$ fert; 4 = Crotalaria + $\frac{1}{2}$ fert 5 = manure; 6 = manure + $\frac{1}{2}$ fert; 7 = tithonia; 8 = calliandra; 9 = leucaena; 10 = tithonia + $\frac{1}{2}$ fert; 11 = calliandra + $\frac{1}{2}$ fert; 12 = leucaena + $\frac{1}{2}$ fert; 13 = rec fert; 14 = control).

On-farm

Farmers visiting the field days in Meru South chose some of the technologies that were demonstrated to them and started trying them out in their farms starting with the SR 2001 season. Results showed that more technologies were implemented in LR 2002 and SR 2002 than in 2001 (Table 4).

Also, maize grain increased as a result of using the introduced technologies over the seasons (Table 3). However, the yields varied significantly among treatments/technologies and across seasons. Mucuna + 30 kg N ha^{-1} , cattle manure + 30 kg N ha^{-1} and leucaena alone gave the highest yields of more than 4.5 Mg ha^{-1} during SR 2002 an indication that these are some of the technologies that could be recommended as bets bet for farmers. Generally, modifications by farmers, mainly mixing of the different organic materials, were observed to give higher yields than most of the other practices implemented by the farmers. The main reason advanced by farmers for mixing the materials was that they lacked adequate materials for incorporation and that they already knew that their soils were low in soil fertility and thus needed large amounts of biomass. The materials mixed mainly consisted of the easily available organics (tithonia and manure) and the herbaceous legumes. Farmers indicated that they added manure or tithonia to the legumes so that the legumes

would grow vigorously and provide a lot of biomass for applying into the soil during the following season. This is important, as the amount of plant nutrients supplied via organic materials is highly dependant on the quantity of the organic materials applied (Mathews et al., 1992).

These farmer innovations could hold the key to improving soil productivity in the region as farmers report inadequate biomass for incorporation into the soil as a major constraint. Akiwumi and Chinau (2002) reported modification of alley farming technology for soil fertility improvement in Nigeria and noted that farmers' innovations is what finally remain on farmers' fields as this is what best suits the farmers needs.

Impact of the introduced technologies

Farmers practicing the new technologies initially mentioned lack of sufficient biomass (tithonia, calliandra and leucaena) and finances to purchase manure and fertilizer in the required quantities as some of the constraints to adoption of the proposed soil fertility improvement technologies. However, with time they started planting trees for biomass production along fences and on terraces. They have also learnt how to manage manure more effectively. Some of the farmers have modified the technologies to fit in their

Table 4. Average on-farm maize yields (Mg ha^{-1}) under different technologies during the SR 2001, LR 2002 and SR 2002 seasons at Chuka, Meru South District.

Technology	Seasons		
	Grain weight (Mg ha^{-1})		
	SR 2001	LR 2002	SR 2002
Mucuna	–	1.6	2.7
Crotalaria	–	0.4	2.5
Mucuna + 30 kg N ha^{-1}	2.4	1.2	5.3
Crotalaria + 30 kg N ha^{-1}	3.3	4.5	
Cattle manure	0.3	2.1	4.2
Cattle manure + 30 kg N ha^{-1}	2.8	3.0	4.8
Tithonia	1.9	1.3	2.4
Leucaena	3.7	0.2	4.7
Tithonia + 30 kg N ha^{-1}	–	2.8	3.4
Calliandra + 30 kg N ha^{-1}	–	1.2	4.4
Leucaena + 30 kg N ha^{-1}	2.4	2.1	–
60 kg N ha^{-1}	3.2	3.0	3.9
*Cattle manure + tithonia	1.8	–	4.2
*Cattle manure + mucuna + 30 kg N ha^{-1}	–	4.3	3.3
Control	1.0	0.4	1.4
SED	1.1	1.2	1.5

*Modification by farmers.

own environments in very innovative ways; for example, instead of maize some farmers started growing vegetables using tithonia. The participating farmers said that they had observed better performance of crops using the new technologies and that the cost of production had been reduced and soil fertility improved. In the SR 2002, 206 farmers were already working with these technologies.

Conclusions and recommendations

The on-station and off-station trials showed promising results in using organic inputs for soil fertility improvement when they are incorporated into the soil. At Embu on-station trial, maize monocrop with prunings of either calliandra or leucaena applied gave highest yields of about $3.5 \text{ Mg ha}^{-1} \text{ season}^{-1}$. On average, leucaena alley cropping treatment gave better yields than the recommended rate of fertilizer, and calliandra alley crop treatments. At the off-station trial at Meru south, tithonia alone and tithonia combined with 30 kg N ha^{-1} gave the highest overall yields of more than 6.0 Mg ha^{-1} . Generally, integration of organic and inorganic nutrient sources gave highest yields which were attributed to increased fertilizer use efficiency and provision of more balanced nutrients to the crop. On the

individual farms, farmers modified the technologies by mixing the different organic materials, for example, manure plus legumes. These farmer modifications gave among the highest yields possibly due to increased nutrient supply. Farmers practicing the new technologies benefited from increased crop yields and have tried to cope with the problem of lack of adequate biomass by planting trees for biomass production on their farms.

Application of organic materials, especially calliandra, leucaena and tithonia to improve crop production should be encouraged among smallholder farmers. Alley cropping using calliandra adversely affected crop production and should not be recommended for this area. There is need for farmer follow-up to assess adoption process and technology adaptation.

Acknowledgements

The authors would like to thank the Rockefeller Foundation, the Swedish International Development Agency (Sida) through the National Agroforestry Research Project and AfNet (TSBF-CIAT) for continued support for this research work. The support from the collaborators from KARI, KEFRI and ICRAF, the staff of National Agroforestry Research

Project at Embu and Kenyatta University (Department of Environmental Science) is truly acknowledged and highly appreciated. The cooperation and contributions by researchers and Kirege community members (farmers and administration) are also acknowledged.

References

- Akiwumi A.A. and Chianu J. (2002) Determinants of farmers' adoption and adaptation of alley farming technology in Nigeria. *Agrof Syst* 55: 99–112.
- Fertilizer Use Recommendation Project (FURP), 1987. Description of first priority site in the various districts. Final Report. Vol 24. Embu district. National Agricultural Research laboratories, Nairobi, Kenya.
- Gachengo C. 1996. Phosphorus release and availability on addition of organic materials to Phosphorus fixing soils. MPhil thesis, Moi University, Eldoret, Kenya.
- Gitari J.N., Dyke E.A. and Maina P. 1997. Legume screening for soil fertility improvement, food and fodder utilization in medium altitude areas of Mount Kenya region. In: Mureithi J.N., Mwendia C.W., Muyekho F.N., Anyango M.A. and Maobe S.N. Participatory Technology Development for Soil Management by Smallholders in Kenya. A compilation of selected papers presented at the Soil Management and Legume Research Network Project Conference Kanamai, Kenya. National Agricultural Laboratories, Nairobi, Kenya.
- Government of Kenya 2001. The 1999 Kenya National Census results. Ministry of Home Affairs, Nairobi, Kenya.
- Gutteridge R.C. 1992. Evaluation of the leaf of a range of tree legumes as a source of nitrogen for crop growth. *Experimental Agriculture* 28: 195–202.
- Heinemann A.M. 1992. Growth and yield of eight agroforestry tree species in line plantings in Western Kenya and their effects on maize yields and soil properties. *Forest Ecology and Management* 91: 103–135.
- Jaetzold R. and Schmidt H. 1983. Farm management handbook of Kenya. Natural conditions and farm information. Vol. 11/ C. East Kenya. Ministry of Agriculture, Kenya.
- Jama B., Buresh R.J., Ndafa J.K. and Shepherd K.D. 1998. Vertical distribution of roots and soil nitrate; tree species and phosphorus effects. *Soil Sci. Soc. Am. J.* 62(1): 280–286.
- Kapkiyai J.J., Karanja N.K., Woome P. and Qureshi J.N. 1998. Soil organic carbon fractions in a long-term experiment and the potential for their use as a diagnostic assays in highland farming systems of central Kenya. *African Crop Science Journal* 6: 19–28.
- Kihanda F.M. 1996. The role of farmyard manure in improving maize production in the sub-humid Central highlands of central Kenya. PhD Thesis, UK.
- Mafongoya P.L. and Nair P.K.R. 1997. Multipurpose tree prunings as a source of nitrogen to maize under semiarid conditions in Zimbabwe. *Agrof Syst* 35: 31–46.
- Mathews R.B., Holden S.T., Volk J. and Lengu S. 1992. The potential of alley-cropping in improvement of cultivation systems in the high rainfall areas of Zambia I. Chitemene and Fundikila. *Agrof Syst* 17:219–240.
- Minae S. and Nyamai D. 1988. Agroforestry research proposal for the Coffee based land use system in the bimodal highlands, Central and Eastern provinces, Kenya. *AFRENA Report No. 16*. International Centre for Research in Agroforestry, Nairobi, Kenya. pp 58.
- Mugendi D.N., Nair P.K.R., Mugwe J.N., O'Neill M.K. and Woome P.L. 1999. Calliandra and Leucaena alley cropped with maize. Part 1: Soil fertility changes and maize production in the sub-humid highlands of Kenya. *Agrof. Syst.* 46: 39–50.
- Mugendi D.N., Kanyi M., Kung'u J.B. and Wamicha W. 2003. Mineral-N movement in an agroforestry system in the Central Highlands of Kenya. In: Mureithi J.G., Macharia P.N., Gichuru M., Mburu M.W.K., Mugendi D.N. and Gachene C.K.K. (eds.) Proceedings of the 18th Soil Science Society of East Africa Conference held in Mombasa on 4th–8th Dec. 2000. pp 287–300.
- Mugwe J.N. and Mugendi D.N. 1999. Use of leguminous shrubs for soil fertility improvement in sub-humid highlands of Kenya. Soil Science Society of East Africa Proceedings of the 17th conference, Pg 194–198 Tenywa J.S., Zake J.Y.K., Ebatat P., Semalulu O, Nkalubo S.T. (Eds) 6–10 September 1999, Kampala, Uganda.
- Murithi F.M., Thijssen H.J.C., Mugendi D.N., Mwangi J.N., O'Neil M.K. and Nyaata O.Z. 1994. Report of a survey on agroforestry technologies used for fodder production and soil fertility improvement in Meru District, Kenya. National Agroforestry Regional Project, Regional Research Centre, Embu, Kenya.
- Mutuo P.K., Mukalama J.P. and Agunda J. 2000. On-farm testing of organic and inorganic phosphorous source on maize in Western Kenya. In: The Biology and Fertility of Tropical Soils: TSBF Report, pp 22.
- Mwangi J.N. 1997. Effect of soil incorporated leaf prunings on soil productivity in alley and sole cropping systems using *Leucaena leucocephala* (Lam) de Wit and *Calliandra calothyrsus* Meissn. M. Phil. thesis, Moi Univ., Eldoret, Kenya.
- Nziguheba G. and Mutuo P.K. 2000. Integration of *Tithonia diversifolia* and inorganic fertilizer for maize production. In: The Biology and Fertility of Tropical Soils: TSBF Report, pp 23.
- Rosecrance R.C., Rogers S. and Tofinga M. 1992. Effect of alley cropped *Calliandra calothyrsus* and *Gliricidia sepium* hedges on weed growth, soil properties and taro yields in Western Samoa. *Agroforestry systems* 19: 57 – 66.
- Sanchez P.A. and Jama B.A. 2002. Soil fertility Replenishment Takes off in East and Southern Africa. In: Vanlauwe B., Diels J., Sanginga N. and Merckx R. (Eds.), Integrated Plant nutrient Management in Sub-Saharan Africa: From concept to practice. CAB International Wallingford, Oxon, UK.
- Tian G., Kang B.T. and Brussaard L., 1993. Mulching effect of plant residues with chemically contrasting compositions on maize growth and nutrients accumulation. *Plant and Soil* 153: 179–187.
- Vanlauwe B., Diels J., Aihou K., Iwuafor E.N.O., Lyasse O., Sanginga N. and Merckx R. 2002. Direct interactions between N fertilizer and Organic matter: Evidence from trials with ¹⁵N-labelled fertilizer. In: Vanlauwe B., Diels J., Sanginga N. and Merckx R. (Eds.) Integrated Plant nutrient Management in Sub-Saharan Africa: From concept to practice. CAB International Wallingford, Oxon, UK.
- Wokabi S.M. 1994. Quantified land evaluation for maize yield gap analysis at three sites in the Eastern slopes of Mt. Kenya. International Institute for Aerospace Survey and Earth Science (ITC) The Netherlands.

Effects of organic and mineral sources of nutrients on maize yields in three districts of central Kenya

Kimani S.K.^{1*}, Esilaba A.O.¹, Odera M.M.¹, Kimenye L.², Vanlauwe B.³ and Bationo A.³

¹Kenya Agricultural Research Institute, Muguga South, P.O. Box 30148, Nairobi, Kenya.

²Department of Agricultural Economics, University of Nairobi, P.O. Box 29053, Nairobi, Kenya.

³Tropical Soil Biology and Fertility Institute of CIAT, P.O. Box 30677, Nairobi, Kenya.

*Corresponding author: Kenya Agricultural Research Institute, Muguga South, PO Box 30148 Nairobi, Email: skimani@africaonline.co.ke

Abstract

Trials were set up in three districts of central Kenya to evaluate organic and mineral sources of nutrients and their effects on maize yields. The experiments were set up during the long rains 2004 with fifteen different soil fertility management treatments. The treatments included cattle manure, green manures, maize stover, *Tithonia*, and mineral fertilizer. The test crop was maize (*Zea mays*), intercropped with beans (*Phaseolus vulgaris*). The experimental design was a Randomized Complete Block with three replicates. At final harvest at maturity, grain yield data were recorded. In general the yields were low ($\leq 1\text{t ha}^{-1}$) in the unfertilized control, in plots intercropped with green manure cover crops, and where maize stover alone was applied. In Kirinyaga, and Maragwa, the highest maize grain yields (6.5t ha^{-1}) were obtained when manure was combined with mineral fertilizer. The responses were not as clear in the Kiambu site, possibly due to soil acidity at the site. There were no significant difference ($p = 0.05$) in grain yields between the green manure cover crops ($0.4\text{--}1.5\text{t ha}^{-1}$), maize stover ($0.3\text{--}0.9\text{t ha}^{-1}$) and the unfertilized control ($0.4\text{--}1\text{t ha}^{-1}$) across treatments and sites during this first season. The work confirms the efficiency of combining mineral sources of nutrients with organic inputs.

Introduction

Maize (*Zea mays*) is the staple food crop in Kenya and is grown over a wide range of agro-ecological zones. The area under maize production is estimated has presently stagnated at 1.5 million hectares, with an expected national production of 2.52 million tonnes and a national consumption of 3 million tonnes (Government of Kenya, 2002), indicating a production deficit. Soil fertility depletion in smallholder farms is the major cause for declining per-capita food production in most of sub-Saharan Africa (Sanchez et al., 1997). The central Kenya Highlands, where this study was carried out, covers approximately 18% of the land

area of the country but contains around 64% of the population, with population densities in excess of 1,000 people per square kilometre in many areas (Braun et al., 1997). In this highly populated region, maize yields can decline by about 30% in the absence of fertilizer and/or manure application (Quereshi, 1987). The use of inorganic fertilizers can overcome most of this soil fertility decline. A survey in Kiambu district, central Kenya showed high cost and unavailability of fertilizer as major constraints to fertilizer use in maize production (Makokha et al., 2001). An alternative to this, is the utilization of farm-derived sources of crop nutrients such as crop residues, composts and farmyard manure (Delve et al., 2001; Lekasi, 2000; Kihanda, 1996).

Legume cover crops and biomass transfer from trees and shrubs growing along farm borders have also been used as alternative sources of nutrients (Jama et al., 2000; Mafongoya and Nair, 1997).

In central Kenya, manure is the most widely used organic fertilizer, by approximately 80% of households (Makokha et al., 2001). Of these about 90% of farmers use manure from their farms, while 10% either purchase it or are given free. However, in the majority of farms, the available manure is not enough to fertilize the farms (Makokha et al., 2001; Lekasi et al., 1998; Kihanda, 1996; Kagwanja, 1996). Most manures from farmers fields have less than 1% N and therefore do not contain enough nutrients to sustain crop production (Giller et al., 1997). In comparison, legume cover crops can have over 3% N (Palm et al., 2001). In addition, manures can have beneficial effects on other factors, for example, improvement in soil physical conditions such as improved moisture retention and addition of micronutrients, other than N and therefore play an important role in production systems (Kihanda and Gichuru, 1999). The best option would be to overcome the nutrient deficiencies through the combined use of cattle manures with modest amounts of inorganic fertilizers as a strategy to maintain and enhance soil fertility.

To date there are no recommended guidelines for combining organic and inorganic nutrients because of inadequate experimental design and little information on the quality of organic inputs used (Palm et al., 1997). However, recent studies to better define manure quality, and possible combinations with mineral fertilizers have been useful in furthering the hypothesis of manure and mineral fertilizer combinations (Kimani and Lekasi, 2004; Kimani et al., 2004).

The objectives of this study were therefore to compare the effects of different sources of organic nutrients on maize production.

Materials and methods

Experimental sites: The study sites were three districts of central Kenya, namely Kirinyaga, Maragwa and Kiambu. These districts differ in socio-economic conditions and also in soil fertility management.

On-farm trials were conducted at one site in each of the three districts that were identified to be N deficient. The trials were set up at Mukanduini area of Kirinyaga (0°35' S, 37° 17'E 1000 m a.s.l.), Kariti (0°52' S, 37° 01' E, 2000 m a.s.l.) in Maragwa and Githunguri

(0° 56'S 37° 05' E, 2200 m.a.s.l) in Kiambu. At Kariti, mean annual rainfall is 1300–1600 mm and annual mean temperatures of 19.7–18.0°C. Githunguri has a mean annual rainfall of 1200–1400 mm and annual mean temperature of 18.4–19.5°C, while Mukanduini has a mean annual rainfall of 1000–1200 mm and annual mean temperatures of 21–22°C. The soils for the three sites are well-drained, extremely deep, dusky red to dark reddish brown, friable clay (Humic Nitisol). Surface soils were sampled (0–15cm), air-dried and ground to pass a 2 mm sieve and characterized for pH (in water), total C (Walkley-Black), total N (Kjeldahl), total P, Ca, Mg and K (extracted in NH₄OAc). Details of the analytical methods are described by Anderson and Ingram (1996).

Three field trials with 15 different soil fertility treatments were established in each of the study Districts. Plots sizes were 4 by 6m with three replicates in a randomized complete block design. Maize was sown at a spacing of 90 by 30 cm during 4th April at Kirinyaga, 24th April at Kandara and during 25th April at Githunguri. Beans were also planted in plots where leguminous green manures were not included. The varieties of maize planted were H13 in both sites. Rose coco beans were used for the inter-planting. The maize was harvested at maturity on 3rd, 10th and 19th September 2003 for Mukanduini, Kariti, and Githunguri respectively. This paper only reports on the maize yield data.

The 15 soil fertility management technologies included unfertilized control, manure + mineral fertilizer (5t ha⁻¹; 20kg N ha⁻¹), manure + mineral fertilizer (5t ha⁻¹; 40 kg N ha⁻¹), manure + mineral fertilizer (5t ha⁻¹; + 60kg N ha⁻¹), and manure + mineral fertilizer (5t ha⁻¹; +80kg N ha⁻¹). Other treatments included compost (10t ha⁻¹), maize stover (5t ha⁻¹ + decomposing bacteria, EM1), maize stover alone (5t ha⁻¹), tithonia (5t ha⁻¹) and the green manure cover crops mucuna (*Mucuna pruriens*), crotalaria (*Clotalaria ochlereuca*) and Dolichos (*Dolicos lablab*). The rest of the treatments comprised mineral fertilizer (100 kg N ha⁻¹), manure (5t ha⁻¹) and manure (10t ha⁻¹).

Grain yield data were collected at final harvest, which was done on 3rd, 10th, and 19th September respectively for Mukanduini, Kariti and Githunguri respectively.

Statistical analysis

Data were analyzed using SAS (SAS Institute Inc. 1988). Significant differences between treatments are reported at the p≤0.05 level.

Table 1. Three-site characterization in Central Kenya.

Site	Depth	PH	% C	Mineral N ppm	% N	ppm P	ppm K	ppm Ca	ppm Mg	ppm Na	CEC (cmol/Kg)
Kariti	0–20	4.98	1.06	14.65	0.19	81.073	376.699	1217.800	93.56	9.087	4.440
	20–40	5.01	1.22	12.69	0.20	50.631	327.132	1422.467	125.56	9.087	4.958
	40–60	5.32	1.10	10.18	0.18	22.275	354.040	1566.267	157.56	9.769	5.522
Kirinyaga	0–20	5.63	1.07	41.11	0.13	505.547	98.073	965.533	588.22	12.803	4.139
	20–40	5.60	0.80	37.85	0.11	429.991	61.067	915.400	515.11	12.291	4.105
	40–60	5.70	0.82	12.78	0.06	357.547	51.816	867.067	371.00	11.779	3.450
Kiambu	0–20	4.61	1.92	37.92	0.20	33.020	210.712	394.633	131.67	20.279	2.164
	20–40	4.56	2.23	27.77	0.21	20.843	162.774	373.300	106.44	15.228	1.860
	40–60	4.67	1.83	24.65	0.19	13.287	128.532	441.433	133.89	11.187	2.040

Results and discussion

Table 1 shows the general characteristics of the soils based on some selected parameters. Soil pH was around 5 for Kariti and 4.6 for Githunguri. The Kariti soil could be described as moderately acidic, whilst the Githunguri soil is strongly acidic. The carbon content was higher for Kiambu at 2% compared to Kariti at 1.1%. The higher C levels may have contributed to the relatively higher mineral N at Githunguri. P levels were lower in Kiambu at 30 ppm compared with Kariti at 80 ppm for surface soils and highest in Kirinyaga. The cation exchange capacity was much lower in Kiambu at 2 cmol kg⁻¹, compared with Kandara at 5 cmol kg⁻¹, which could be attributed to lower levels of Ca and K at Githunguri. From the soils data, it appeared that the Githunguri soil was less fertile compared to Kariti. Soil fertility at the Kirinyaga site could be described as in between the other two sites, with more favorable soil pH > 5.5, but with exceptionally high values of available P at 500 ppm for surface soils.

Maize grain yields

Overall, grain yields were higher at Kariti, followed by Mukanduini and lowest in Githunguri (Table 2).

Manure alone when applied at 5 t ha⁻¹ increased grain yields by 300%, 164%, and 500% at Mukanduini, Kariti and Githunguri respectively. Increasing the applied manure to 10 t ha⁻¹ resulted in an increase in grain yield of 370%, 300% and 700% respectively for Mukanduini, Kariti, and Githunguri respectively. The results indicate only a slight increase in grain yields at Kariti on increasing the manure rate, from 5–10 t ha⁻¹, but twofold increase at Mukanduini. The greater response Mukanduini and Githunguri could be

Table 2. Mean maize yields during the long rains, 2003 in three sites in Central Kenya.

Treatments	SITE		
	Mukanduini	Kariti	Githunguri
Manure 5t ha ⁻¹	3.996	2.83	2.30
Manure 10 t ha ⁻¹	4.460	4.36	3.04
Manure 5t+20Kg N	3.222	4.28	3.17
Manure 5t+40Kg N	5.378	5.89	2.61
Manure 5t+60Kg N	6.507	6.14	2.61
Manure 5t+80Kg N	6.542	6.82	1.79
100Kg N	3.348	5.24	2.84
Tithonia 5 t ha ⁻¹	4.682	4.02	1.36
Compost 10 t ha ⁻¹	2.980	3.08	2.22
Maize stover 5t ha ⁻¹	0.824	0.78	0.32
Maize stover 5t ha ⁻¹ +EM1	0.853	0.92	0.33
Crotalaria	1.404	1.45	0.73
Dolichos	1.018	1.40	0.56
Mucuna	0.492	1.03	0.73
Unfertilized control	0.944	1.07	0.37
LSD (0.05)	2.16	1.24	1.40

attributed to the water shortages, due to lower total rainfall, particularly at Githunguri (Data not shown) which could have been alleviated by the increase in water holding capacity associated with manure application. Combining manures with mineral fertilizers resulted in high yields at Mukanduini and Kariti. This response was not observed for Githunguri possibly due to the high levels of soil acidity. Similarly for the Githunguri site, the response for the mineral fertilizer was not as pronounced as in the other two sites (Table 2). The combinations resulted in higher yields with the increase in the level of mineral fertilizer application. Combining manure with 40 kg N ha⁻¹ or more mineral fertilizer resulted in

higher yield than using a high rate of mineral fertilizer (100 kg N ha⁻¹).

Tithonia addition increased maize yields significantly at all sites. However the increase was most pronounced at Mukanduini (400%), and Kariti (275%) and less at Githunguri (70%). Maize stover suppressed yields at all sites during this growing season. This is attributable to immobilization of nutrients particularly nitrogen by the stover addition (Delve et al., 2001). Application of bacteria, EM1, on the incorporated maize stover had no effect on maize yield, suggesting that its ability to decompose the maize stover may require further study.

The green manure cover crops were not effective during this season since they had just been introduced. The normal practice is to grow them for the first season, then incorporate them during the subsequent season. Consequently, this paper may not discuss the effects of these amendments.

Conclusions and implications

Soil fertility can be ameliorated by application of manures singly or in combination with mineral fertilizers. Singular application of manure resulted in an increased relative maize yields of 3.5, 3.3, and 2.7t ha⁻¹ for Mukanduini, Kariti, and Githunguri, respectively. The combinations of manure and fertilizer resulted in higher maize yields, compared with the singular application of either manure or mineral fertilizer. This integration, however, may be more feasible, as an option for farmers, considering the high costs of mineral fertilizers, and the level of resource endowment of most farmers in the study areas. Variability in soil fertility across the sites as shown by the carbon and cation exchange capacity levels indicate that formulation of recommendation domains may need to consider this variability. While biomass transfer resulted in more than a fourfold maize yield increase, availability of the materials remains a problem. Finally, it is important to perform economic analysis for the various technologies, in order to develop feasible recommendations for farmers.

Acknowledgements

The authors wish to thank the Rockefeller Foundation and KARI for financial support. We thank KARI

and TSBF-CIAT for facilitating the field and laboratory work. Lastly we acknowledge our field staff, E. Mwangi, JM Kaiyare and S. Aguphane for managing the field trials.

References

- Anderson J.M. and Ingram J.S.I. 1996. Tropical Soil Biology and Fertility. A Handbook of Methods, 2nd Edition. CAB International, Wallingford, UK.
- Braun A.R., Smaling E.M.A., Muchugu E.I., Shepherd K.D. and Corbett J.D. 1997. *Maintenance and improvement of soil productivity in the highlands of Ethiopia, Kenya, Madagascar and Uganda;* Rep. No. No. 6. African Highlands Initiative, Nairobi.
- Castellanos J.Z. and Pratt P.F. 1981. Mineralization of manure nitrogen – correlation within laboratory indexes. *Soil Sci. Soc. of Am. J.* 45: 354–357.
- Delve R.J., Cadisch G., Tanner J.C., Thorpe W., Thorne P.J. and Giller K.E. 2001. Implications of livestock feeding management on soil fertility in the smallholder farming systems of sub-Saharan Africa. *Agricultural Ecosystems and Environment* 84: 227–243
- Giller K.E., Cadisch G., Ehaliotis C., Adams E., Sakala W.D. and Mafongoya P.L. 1997. Building soil nitrogen capital in Africa. In: Buresh R.J. et al. (Eds.) *Replenishing soil fertility in Africa*. SSSA *Spec. Publ.* 51. SSA, Madison, WI, USA, pp. 151–192
- Government of Kenya 2002. National Development Plan (2002–2008) on Effective Management for Sustainable Economic Growth and Poverty Reduction. Government Printer, Nairobi, Kenya.
- Jama B., Palm C.A., Buresh R.J., Niang A., Gachengo C., Nziyheba G. and Amadalo B. 2000. *Tithonia diversifolia* green manure for improvement of soil fertility: A review from western Kenya. *Agroforestry Systems* 49: 201–221.
- Kagwanja J.C. 1996. Determinants of farm level soil conservation technology adoption; lessons from the high rainfall, highly populated, steep sloped Mt. Kenya highlands, Embu Kenya. PhD thesis, University of Missouri-Columbia.
- Kihanda F. 1996. The role of farmyard manure in improving maize production in the sub Humid highlands of central Kenya. PhD thesis, University of Reading, UK
- Kihanda F.M. and Gichuru M. 1999. Manure management for soil fertility improvement. TSBF/AHI Report.
- Kimani S.K. and Lekasi J.K. 2004. Managing manures throughout their production cycle enhances their usefulness as a fertilizer: A review. In: Bationo A. (Eds.). *Managing nutrient cycles to sustain soil fertility in sub-Saharan Africa*. Academy Publishers, Nairobi, pp. 187–198.
- Kimani S.K., Macharia J.M., Gachengo C., Palm C.A. and Delve R.J. 2004. Maize production in central Kenya Highlands using cattle manures combined with modest amounts of mineral fertilizer. *Uganda Journal of Agricultural Sciences* 9: 480–490.
- Kimetu J.M., Mugendi D.N., Palm C.A., Mutuo P.K., Gachengo C.N., Bationo A., Nandwa S. and Kungu J.B. 2004. Nitrogen fertilizer equivalencies of organics of differing quality and optimum combination with inorganic nitrogen source in central Kenya. *Nutrient Cycling in Agroecosystems* 68: 127–135.

- Lekasi J.K., Tanner J.C., Kimani S.K. and Harris P.J.C. 1998. Manure management in the Kenya highlands: Practices and Potential. Emmerson Press, Kenilworth, UK.
- Lekasi J.K. 2000. Manure management in the Kenya highlands: collection, storage and composting strategies to enhance fertilizer quality. PhD Thesis. Coventry University, UK.
- Mafongoya P.L. and Nair P.K.R. 1997. Multipurpose tree prunings as a source of nitrogen to maize under semi-arid conditions in Zimbabwe. Nitrogen recovery rates in relation to pruning quality and method of application. *Agroforestry Systems* 35: 47–57.
- Makokha S., Kimani S.K., Mwangi W., Verkuijl H. and Musembi F. 2001. Determinants of fertilizers and manure use in maize production in Kiambu district, Kenya. Mexico, D.F.:International Maize and Wheat Improvement Centre (CIMMYT) and Kenya Agricultural Research Institute (KARI).
- Palm C.A., Myers R.J.K. and Nandwa S.M. 1997. Combined use of organic and inorganic nutrient sources for soil fertility maintenance and replenishment. In: Buresh R.J., Sanchez P.A. and Calhoun F. (Eds.) *Replenishing soil fertility in Africa*, SSSA, American Society of Agronomy, Madison, Wisconsin, USA, pp 193–217.
- Palm C.A., Gachengo C.N., Delve R.J., Cadisch G. and Giller K.E. 2001. Organic inputs for soil fertility management in tropical agroecosystems: application of an organic resource database. *Agriculture, Ecosystems and Environment* 83: 27–42.
- Qureshi J.N. 1987. The cumulative effects of N-P fertilizers, manure and crop residues on maize grain yields, leaf nutrient contents and some soil chemical properties at Kabete. Paper presented at the National Maize Agronomy Workshop, National Agricultural Laboratories, Nairobi, Kenya, February 17-19, 1987.
- SAS Institute Inc. 1988. SAS Users Guide, Cary, NC, USA.
- Sanchez P.A., Shepard K.D., Soule M.J., Place F.M., Buresh R.J., Izac A.N., Mokwunye A.U., Kwesiga F.R., Ndiritu C.G. and Woome P.L. 1997. Soil fertility replenishment in Africa: An investment in natural resource capital. In: Buresh R.J., Sanchez P. A. and Calhoun F. (Eds.). *Replenishing soil fertility in Africa* pp. 1–46. Soil Science Society of America, Indiana, USA.

Effect of Combining Organic Leafy Biomass and Inorganic fertilizer on Tomato Yields and nematodes control in Arenosols in Kinshasa Area

Mafuka M.-M.¹, Nsombo M.¹, Nkasa C.¹ Ibwenzi K.¹ and Taba K.²

¹Natural Resources Management Department, Faculty of Agriculture, P.O. Box 170, KinXI, University of Kinshasa, D. R. Congo. Tel. +2438931713; E-mail: mpmafuka@yahoo.fr; ²Chemistry Department, Faculty of Science, P.O. Box 117, Kin XI, University of Kinshasa, D. R. Congo.

Abstract

Low soil fertility and crop productivity is a major problem facing all smallholder farmers in Democratic Republic of Congo. The low soil fertility is caused by continuous cropping without addition of adequate external soil fertility inputs. The use of inorganic fertilizers to alleviate this constraint is limited mainly by its high costs, untimely availability and low producer prices. A pot and a field experiment were initiated from 2001 to 2003 to investigate the effect of combining inorganics and organic with leafy biomass types (*Tithonia diversifolia* and *Ricinus communis*) on tomato yields in soil where this crop is sown during the dry and rain seasons using arenosols with soil pH 4.8 to 5.2 and low available P (1.3-2.6 mg P/kg soil)

The combined use of leaf biomass showed that organic matter added in soil reduced crop yield mainly during the rain season. And the negative effect was mainly observed when *Tithonia* leaf biomass was used alone or combined with inorganic fertilizers. Yields were decreased from 10 to 40%. Roots were therefore observed and it appeared that they were infected by knot-born nematodes. However, when *Tithonia* was mixed with *Ricinus*, tomato yields were increased and no knots were observed on roots of tomato plants. The results suggest in that organic matter can also contribute decrease crop yield by increasing density of nematodes which is correlated to soil moisture content and affect plant performance.

Key words: Arenosols, knot-born nematodes, leaf biomass, *Ricinus communis*, tomato

Introduction

Low input agriculture mainly explains the cause of low and declining crop yields in many countries in Sub-Saharan Africa (World Bank, 1996). The soils in Kinshasa area are deep, extremely drained, weathered arenosols with very low inherent fertility. During colonial period, Kinshasa area was considered as an unfertile region where cropping activities should not be done (Sys 1972).

In the recent past there has been increased interest in the use of leaf biomass from woody perennials as a source of nutrients to annual crops (Kang et al., 1990; Jama et al., 2000). The amounts of nutrients released

from organic materials are a function of their physical and chemical composition, the amounts applied and environmental factors (reference). However, in this area no type or quantity of organic materials is recommended. Leaf amendments are sometimes used to increase crop yields or to maintain soil fertility at the moderate level which can allow farmers to continue growing crop in the same field. This is partly due to the fact that inorganic fertilizers are expensive and irregular. In Kinshasa area, phosphorus (P) and nitrogen (N) soil nutrients are deficient in cropping soils (Mafuka and Matia, 1999). The continuous application of organic materials of different quality contributed on moderate crop yields. Surveys carried

out in this area indicate that soil fertility is one of the most important factors limiting crop production and all farmers are fully aware of low and declining soil fertility, but they do not have available resources to replenish soil nutrients. Much research has been done to determine the use of leaf biomass as a source of nutrients in place of inorganic fertilizers and most of this has revealed both advantages and disadvantages of combining nutrient sources. (Palm et al., 1997) However, little predictive understanding for the management of organic materials inputs especially in tropical agroecosystems is not available (Palm et al., 2001). It is therefore difficult to give valid advice to farmers on the best organic materials nutrients sources for direct application and the right combinations with inorganic fertilizers.

Attempts have been made and continue to find correct agricultural practice to grow crop and also to keep soil fertility at moderate level. These include combined applications of leaf amendments of different types and inorganic fertilizer resources.

Among root pests, plant-parasitic nematodes are important problem affecting crop production in sub-Saharan area (Johnson and Fassuliotis, 1984; Duponnois et al., 1997a,b). Roots of tomato plants are affected by root-knot nematodes. Nematicides used for nematode control can no longer be recommended to African smallholder farmers because of their high price. However, some plants have shown their high potential in biological control of the multiplication of nematode infections and used as organic amendments.

This study is a part of research program initiated to investigate the effect of different types of leaf amendments used by smallholder farmers for growing tomato in Kinshasa area. The main objective of the study is to (i) Assess the synergy resulting from integrated use of different types of leaf biomass on tomato crop and (ii) Test the effect of combining some types of leaf amendments and inorganic fertilizers on tomato yields.

Materials and methods

Site description

The experiment was carried out in the station of the Faculty of Agronomy at the University of Kinshasa. The station is located at 15°20'–15°23'E and 04°29'–4°32'S and an altitude of 350–450 m above sea level. The soils are mainly arenosols (FAO, 1990) that are

deep and well weathered. The soils at the experimental site in 0–20 cm soil layer are composed of 0.69% carbon, 0.07% nitrogen, pH of 4.8–5.2, 7.7% clay, 90.9% sand and 25mg/kg⁻¹ extractable P.

Experimental design

The experimental designed was complete randomised design with 6 treatments replicated 4 times. The experiment was conducted from May 2001 to February 2003 both in the pots and field.

Ten-litre plastic pots with surface area of 0.04m² were filled with 10 kg of soil and 50 gm of leaf biomass. The field elementary plot surface was 10 × 10 m and 125 kg of biomass was applied. Tomato seedlings were transplanted in pots Plant were watered daily with tap water and grown outside under natural light (day length approximately 12 hours and mean temperature 28°C).

Two months after transplanting, some plants were harvested and roots were gently washed, the knock-roots (nematode) were therefore counted and the percentages of roots infected were appreciated. For each treatment, the parameters assessed were plant diameter, height, number and weight of fruits per plant and tomato yield.

Statistical analyses

The data collected were subjected to analyses of variance (ANOVA), to compare treatment effects on plant height and tomato yields. ANOVA was conducted using the GENSTAT 5 Committee (1993) statistical package. Treatment differences were evaluated using the least significance difference (LSD) at P = 0.05. In each one of the two experiments (pots and field), each treatment was replicated four times to make a total of 24 experimental units each cultural season.

Results and discussion

In this study, leaf materials were dried over night at 65°C before use (transfer to materials and methods). The effect of leaf amendments on collar diameter of plants, number of fruits per plant and fruit weight of tomato in the pot experiments varied according to the treatments (Table 1). Collar diameter of tomato plants were mainly the same for both growing seasons.

Table 1. Results of the pot experiments.

Treatments	Collar growth (mm)		Fruits number/pl.		Mean of fruits weight (gr)	
	Dry*	Rain*	Dry*	Rain*	Dry*	Rain*
1. Control	9.7 a	9.1 a	4.3 a	2.9	58.0	61.0
2. Tithonia	11.6 b	9.9 ab	12.3 b	9.8	80.3	81.5
3. Ricin	11.9 b	10.3 b	13.4 b	11.7	90.1	81.7
4. Tithonia & Ricin	12.4 b	10.5 b	15.6 c	12.0	79.0	79.4
5. NPK	12.3 b	10.7 b	15.2 c	12.3	79.5	80.0
6. Tithonia + NPK	12.3 b	10.2 b	15.1 c	11.2	78.1	79.0
LSD (5%)	0.9	0.8	1.2	1.1	0.3	0.3

Values in the column with the same letters are not significantly different at 0.05 probability level.

*Season of plant growing.

There was no significant difference between all treatments according to collar growth. The relative values obtained for control are due to low soil fertility of the experiment site as described below.

The results of this experiment shown in Table 1 showed that there was a difference between dry and rain season. The first one improves each parameter studied. Different values recorded during the rain season are low.

From the field experiment, the number of fruits per plant was low during the rain season (Table 2). The effects of the organic amendments were relatively the same for all treatments, no significant difference was observed between them. The yield was significantly higher in the treatments with fertiliser (Table 3). However, the use of tithonia leaves and the inorganic fertiliser decreased yield.

Duponnois et al. (2001) also observed that when leaves of tithonia were mixed into the soil, yield of

tomato decrease. Several environmental factors control decomposition of organic matter (temperature, moisture and soil nutrient level) (Moore, 1986; Hunt et al., 1988) as well as organic quality. The decomposition of organic compounds is important for the function of soil ecosystems, through supply of nutrient elements and as a source of energy for soil microorganisms (Elliot et al. 1988). The organic amendments added into soil stimulate microorganism's growth. Consequently, the development of some parasitic microorganisms of soil may have been responsible of the reduction of tomato yield in our experiment. They may use available nutrient for their biosynthesis. This can be explains yields decrease when tithonia was mixed with inorganic fertilizer or other treatments. Even though, the use of nematicide plants as *Ricinus cummunis* can solve this problem. *Ricinus cummunis* affect soil microorganisms development especially root-knot nematodes by its inhibitory effect on microbial growth. *Ricinus cummunis* can also

Table 2. Results of the Field Experiments.

N°	Treatments	Collar growth (mm)		Fruits number/plant		Mean of fruits weight (gr)	
		Dry*	Rain*	Dry*	Rain*	Dry*	Rain*
1	Control	4,6 a	a	6,1 b	2,6 a	70 a	61,1 a
2	Tithonia	6 b	6 b	4,7 b	2,9 a	97,1 b	80,5 ab
3	Ricinus Tithonia +	6,3 bc	6 b	4,8 b	3,8 b	98,2 b	88,5 b
4	Ricinus	6,6 b	6,3 b	4,6 b	3,8 b	115,3 c	110,2 c
5	NPK	7,3 c	6,5 b	3,9 b	3,9 b	132 d	113 c
6	Tithonia + NPK	7,6 c	6,7 b	3,9 b	3,7 b	119,4 cd	95 bc
	LSD (5%)**	1,1	0,9	0,9	0,5	13,4	19,8

Values in the column with the same letters are not significantly different at 0.05 probability level. * Season of plant growing.

Table 3. Plant Infection and Yield in the Field Experiments.

N° Treatments	Root-knot invasion*		Yields (Kg/100m2)	
	Dry**	Rain**	Dry**	Rain**
1 Control	4	5	159,3a	56,9a
2 Tithonia	3	4	171,6a	74,6ab
3 Ricinus	1	1	207,6ab	109bc
4 Tithonia + Ricinus	2	2	233,3b	128,3c
5 NPK	3	3	349,3c	141,1c
6 Tithonia + NPK	3	4	316c	130,6c
LSD (5%)	—	—	56	38,2

Values in the column with the same letters are not significantly different at 0.05 probability level. *Intensity of infestation by root-knot (1 = low; 5 = high). **Season of plant growing.

be used as organic matter as showed in this study. But, some studies must be carried out to know their nutrient and phenolics contents in leaves and leaf litter.

Values recorded in control were significantly different compared to all treatments. The effect of all treatments was too low during the rainy season probably due to leaching of nutrients. The leaching is very important in the sandy soil of this area and the decomposition of the organic matter is very fast because of the high temperatures. Soils of Kinshasa area are too wet during this season and tomato yield for any variety is low; there is no explanation to this until now. The results further show that the best practice to improve soil fertility does not necessarily lead to increased yield.

Conclusions

This research showed that soil fertility improvement by using organic matter to increase crop yield did not give the expected results. Soil fertility appeared to be one of the factors which affect crop yield. The results of this experiment also showed that future researches should be focused on the type of organic matter to be used to enhance tomato production in the similar areas. This will allow getting more information that can help researchers and farmers to improve their knowledge and the yield of tomato plants.

Acknowledgements

We thank Professor Albert LEMA for his valuable comments on a previous draft.

References

- Duponnois R., Cadet P., Senghor K. and Sougoufara B. 1997a. Etude de la sensibilité de plusieurs acacias australiens au nématode à galles *Meloidogyne javanica*. Ann Sci For 54 : 181–190.
- Duponnois R., Tabula T.K. and Cadet P., 1997b. Etude des interactions entre trios espèces d'Acacia (*Faidherbia albida* Del., *A. seyal* Del., *A. holosericea* A Cunn ex G. Don) et *Meloidogyne mayaguensis* au Sénégal. Can J Soil Sci 77: 359–365.
- Duponnois R., Chotte J.L. and Sall S. 2001. The effects of organic amendments on the interaction between a nematophagous fungus *Artrobotrys oligospora* and the root-knot nematode *Meloidogyne mayaguensis* parasitizing tomato plants. Biol Fertil Soils 33:1–6.
- Elliot E.T., Hunt H., Walter D.E., 1988. Detrital foodweb interactions in North American grassland ecosystems. Agri Ecosyst Environ 24: 41–51.
- FAO (Food and Agriculture Organisation), 1990, New Environmental Treat: Declining Soil Fertility. Land and Water Technical Newsletter
- Genstat 5 Committee, 1993, Genstat release reference manual. Oxford University Press, Oxford U.K.
- Hunt H., Ingham E., Coleman D.C., Elliot E.T. and Reid C. 1988. Nitrogen limitation of production and decomposition in prairie, motain meadow, and pine forest. Ecology 69:1009–1016.
- Jama B. Palm C.A., Buresh R.J., Niang A. Gachengo C., Nziguheba G. and Amadalo B., 2000. Thitonia diversifolia as a green manure for soil fertility improvement in western Kenya: A review. Agroforestry systems 49: 201–221.
- Johnson A.W. and Fassuliotis G. 1984. Nematode parasites of vegetable crops. In: Nickle W.R. (ed) Plant and insect nematodes. Dekker, New York, pp 323–372.
- Kang B.T., Reynolds L. and Atta-Krah A.N. 1990. Alley cropping farming. Advances in Agronomy 43 : 315–359.
- Mafuka M.M. and Matia K. 1999. Effect of guano and lime on nodulation, grown and grain yield of soybean (*Glycine max* C.L.) var. Afya. Revue congolaise des Sciences Nucléaires, 15: 116–121.
- Moore A.M. 1986. Temperature and moisture dependence of decomposition rates of hardwood and coniferous leaf litter. Soil Biol Biochem 18: 427–4335.

- Palm C.A., Myers R.J. and Nandwa S.M. 1997. Combine used of organic and inorganic nutrient sources for soil fertility maintenance and replenishment. In Buresh, R.J. and Sanchez P.A. (eds) Replenishing soil fertility in Africa SSSA spec. Publ. 51. SSSA, Madison, WI.
- Palm C.A., Gachengo C.N., Dalve R.J., Cadisch G. and Giller K.E. 2001. Organic inputs for soil fertility management in tropical agroecosystems : application of an organic resource database. *Agriculture, Ecosystems and Environment* 83: 27–42.
- Sys C. 1972. Caractérisation morphologique et physico-chimique de profils types de l'Afrique centrale. Publications INEAC
- World Bank 1996. Natural Resource Degradation in Sub-Saharan Africa. Restoration of soil fertility, Africa Region. World Bank: Washington D.C. USA.

Nutrient Dynamics On Smallholder Farms In Toghane, Northern Highlands Of Ethiopia

Assefa Abegaz^{1,2*}, Herman van Keulen^{2,3}, Mitiku Haile¹ and Simon J. Oosting⁴

¹Mekelle University; ²Plant Production Systems Group, Wageningen University and Research Centre; ³Plant Research International, Wageningen University and Research Centre; ⁴Animal Production Systems Group, Wageningen University and Research Centre; * Corresponding author: Assefa Abegaz; current address: Plant Production Systems Group; P.O. Box 430, 6700 AK Wageningen, The Netherlands; Telephone +31 317 482057, E-mail: assefa.abegaz@wur.nl or assefa_abegaz@yahoo.com

Abstract

To evaluate the sustainability of agricultural systems, the dynamics of nitrogen (N), phosphorus (P) and potassium (K) were studied at field and farm scales in Toghane micro-catchment, Northern Highlands of Ethiopia. Three farm wealth groups (rich, medium and poor) were distinguished based on farm size, capital assets and grain stocks. The NUTMON questionnaire and software have been used for data collection and calculation of partial macronutrient balances. The study indicates that total input to farm fields of all three macronutrients does not balance nutrient removal in crop yield and animal feeds. Consequently, N, P and K stocks in the soil are rapidly declining, with annual depletion rates higher for the rich group (2.4% of total N, 1.3% of total P and 1.3% of total K) than for the poor group (1.0% of total N, 0.2% of total P and 0.4% of total K), and the medium group taking an intermediate position. For all three groups, current farm management is not sustainable. The study clearly identifies the need for the development of integrated nutrient management systems to reduce the high rates of nutrient depletion and to transfer to sustainable farm management systems. Three possible measures can be suggested: First, improvements in nutrient use efficiency from manure, which could be attained through judicious management, i.e. manure must be carefully stored to minimize physical loss of the manure/compost and nutrients, and that manure must be applied to the appropriate crop with the appropriate method at the proper time. Secondly, introduction of energy-saving stoves to reduce use of cattle dung for fuel and consequently increasing manure availability for field application. Thirdly, application of more external chemical fertilizer, together with improved rainwater harvesting for supplementary moisture supply.

Key words: Mixed farming systems, nutrient balances, nutrient mining, NUTMON

Introduction

Agriculture is the basis of the Ethiopian economy, accounting for 46% of its GDP and 90% of its export earnings and employing 85% of the country's labor force (UNDP, 2002). About 95% of the agricultural output originates from subsistence smallholder farms in the highlands (ADF, 2002). The country's long-term economic development strategy, 'Agricultural Development-Led-Industrialization'

(ADF, 2002), has been designed to target these smallholders' private agricultural economy with the aim of maintaining food security and supporting economic growth. Moreover, it aims at initiating development of home industries, stimulating the service sectors and creating additional purchasing power. These objectives illustrate the important role envisaged for agriculture in the Ethiopian economy (Block, 1999). For attainment of the goals formulated for agriculture, sustainable agricultural development is a pre-requisite, for which

development of appropriate soil fertility management systems is one of the tools (Terry, 1999). However, most of the environmental problems facing the country are associated with subsistence agriculture-related activities (UNEP, 2002), such as inappropriate land management practices associated with low external nutrient inputs and population pressure (UN, 2002). Agricultural practices based on low external input levels carry the risk of depleting soil nutrient stocks, seriously threatening the sustainability of agricultural production (Hengsdijk et al., 2005; Tellarini and Caporali, 2000; Elias et al., 1998; Harris, 1998; Bojo and Cassels, 1995; Stoorvogel and Smaling, 1990). Within the farming systems of the Ethiopian highlands, only small amounts of manure are applied to arable crops (cattle dung cakes are predominantly used for fuel) and most crop residues are used as animal feed. Fallowing, for natural soil fertility replenishment, has almost completely disappeared from agricultural practice, due to the small farm sizes associated with high population pressure.

Soil nutrient dynamics are important sustainability indicators for agricultural production systems (Smaling, 1998). Soil nutrient status in agricultural systems is, on the one hand, determined by physical, chemical and biological processes in the soil, which are affected by climate, soil type and topography (Janssen, 1999) and, on the other hand, by farm management practices. Inappropriate farm management practices play a role in the development of unsustainable agricultural systems (Stoorvogel and Smaling, 1990).

Many of the previous studies on land degradation in Ethiopia have focused on losses of nutrients through physical soil erosion caused by run-off (Belay, 1992; FAO, 1986; Constable, 1984). Since the beginning of the 1990s, attention has also been paid to removal of economic yield and all crop residues from agricultural land as one of the major components of soil nutrient depletion (Tellarini and Caporali, 2000; Elias et al., 1998; Harris, 1998; Bojo and Cassels 1995; Stoorvogel and Smaling, 1990). Rates of nutrient depletion in Africa have been quantified at various spatial scales and for different farming systems (for example Stoorvogel and Smaling (1990) for Sub-Saharan Africa, Van der Pol (1992) for southern Mali, Smaling et al. (1993) for Kisii district of Kenya). Based on such studies, it has been concluded that analysis of inputs and outputs of the macronutrients, nitrogen (N), phosphorus (P) and potassium (K) is an important component of sustainability assessment of farming systems. Although doubts have been voiced about the usefulness of nutrient balance studies for sustainability

evaluation (Scoones and Toulmin, 1998), careful analysis of the inflows and outflows of nutrients from farming systems may reveal imbalances, and may serve as a starting point for the design of modifications in the system, leading to more balanced nutrient flows. Moreover, the results may serve as awareness raisers for the local farming community and to alert policy makers (Janssen, 1999).

The Sub-Saharan Africa study by Stoorvogel and Smaling (1990) indicated that Ethiopia is one of the countries with the highest rates of nutrient mining, with aggregated national values of -41 kg of N, -6 kg of P and -26 kg of K ha^{-1} . However, Ethiopia is characterized by diverse climatic conditions, soil types and topography, resulting in a wide variety of farming systems, each with its specific nutrient management system, and the associated rates of nutrient addition or depletion. For instance, Elias et al. (1998), in their nutrient balance analyses, recorded high rates of N depletion by well-endowed (annually -102 kg ha^{-1}) and medium-endowed farmers (-88 kg) in the highlands and -24 kg ha^{-1} by poor and -57 kg ha^{-1} by very poor farmers in the lowlands in Kindo Koisha district, southern Ethiopia. Such results can not be extrapolated to the Northern Highlands of Ethiopia, characterized by completely different relief, climate conditions, soil types, history of farming, and farm management systems. For example, a recent study at plot scale in cultivated fields in the Northern Highlands of Ethiopia (Hengsdijk et al., 2005) reported a negative balance of 27 kg N ha^{-1} . Hence, there is a need for assessment of nutrient dynamics at field and farm scales in different localities and under different socio-economic conditions, as a basis for the design of technically feasible, ecologically non-degrading, and economically viable nutrient management strategies. The study described in this paper responds to that need, reporting on assessment of partial macro-nutrient balances at field and farm scale in Tegahane, in the Northern Highlands of Ethiopia.

Materials and methods

The study area

The study was conducted during 2002–2003 in Tegahane, Atsbi Wonberta district, situated between $13^{\circ}52'53''$ and $13^{\circ}53'37''$ NL and between $39^{\circ}42'05''$ and $39^{\circ}43'57''$ EL, in Tigray Regional State in the Northern Highlands of Ethiopia, covering an area of 13.56 km^2 . Its altitude ranges from 2720 to 2880 m

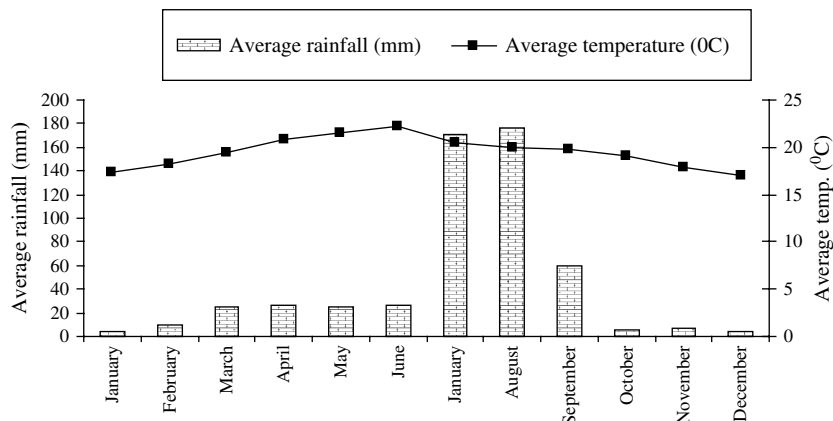

Figure 1. Average monthly rainfall and temperature for Teghane, 1901–2002 (Source: Viner, 2003).

above mean sea level. The climate is ‘Dega’ (MOA, 2002), with average annual monomodal rainfall from July to September of 541 mm (coefficient of variation 53%, for the period 1901–2002, at a location near Teghane at 14°NL and 40°EL (Viner, 2003)) (Figure 1). For the period 2000–2004, average annual rainfall was 532 mm (Atsbi World Vision, 2004), i.e. comparable to the long-term average. The year in which the data were collected represents an ‘average’ production situation for the area (local farming experts, pers. comm.).

Farming systems

The dominant farming system in Teghane is a subsistence mixed crop-livestock system. Smallholder farmers integrate crop and animal production to maximize returns from their limited land and capital resources, minimize production risk, diversify sources of income, provide food security and increase productivity (Paris, 2002).

Annual food crops, such as barley (*Hordeum* spp.) and wheat (*Triticum* spp.) are the major crops, grown on 66 and 14%, respectively of the cultivated land in 2002. Field pea (*Pisum* spp.) and faba bean (*Vicia* spp.) are the next important crops, occupying 10 and 9%, respectively. Most of the grazing lands are in the valley bottom, where water logging is a serious problem for growth of crops. Marginal fields are under open woodland and prickly pear (*Opuntia* spp.). Climatic factors, i.e. rainfall pattern and temperature, mainly control the crop calendars. The main cropping period is the rainy season between July and October, whereas from March

to June barley and some vegetables are grown in small irrigated fields.

The farm animals provide draft power and manure for crops. Dried animal manure is used extensively as a source of household energy. Crop residues are used as feed for livestock. Outputs from livestock, such as milk, meat and eggs are important sources of food for the family. Cash from the sales of crop products, animal products and animals is used to purchase farm inputs and cover expenditures for schooling, clothing and veterinary costs. Hence, livestock serves as a capital asset, in the form of a readily available source of cash and means of savings (Mohamed Saleem, 1998; Slingerland, 2000; Paris, 2002; Udo, 2002; Bebe, 2003).

Farm selection

Farmers were classified according to the community’s viewpoint, during a village farmers’ assembly, in three wealth groups (rich, medium and poor), on the basis of the socio-economic conditions in Teghane. The criteria used were land holding, herd size (HS) and the stock of seed/grain for planting and consumption, i.e., farmers in the ‘rich’ group possessed land >1 ha, oxen = 2, cows = 2 and had enough seed/grain in stock to cover the requirements for planting and consumption, in the ‘medium’ group farmers possessed 0.75–1 ha, one ox and one cow and the ‘poor’ group possessed land holdings <0.75 ha and owned one or no oxen, one or no cow and few other animals and had insufficient seed/grain in stock for planting and consumption. Through stratified random sampling, five households from the rich, seven

from the medium and 12 from the poor group were selected from the list of all households of the village. Three experts in local farming practices were consulted on past farming practices in the area.

Framework for analysis of N, P and K flows

The NUTMON toolbox (Van den Bosch et al., 2001) was used to analyze nutrient flows. The NUTMON-methodology is based on systematic collection of information from the farm household on farm characteristics, farm practices and farm management. This information, both quantitative and qualitative, is used to quantify flows of material (with emphasis on nutrients) and cash through the farm system. Information collection starts with the *farm inventory*, that is, in principle, repeated before each crop cycle. In the farm inventory, information is collected on the farm household, i.e. its composition, and its assets (land, capital goods, i.e. machinery and animals). The farm household is characterised in terms of available labour and consumer units. Also the education level of the head of the household is recorded. The available land resources are specified in terms of both, *Farm Section Units (FSU)* (land units with more or less 'stable' soil characteristics) and *Primary Production Units (PPU)* (land

units dedicated to production of a certain commodity in a given season). Capital goods are specified, such as hoe(s), plough(s), etc. Animals present at the farm (*Secondary Production Units (SPU)*) are defined in terms of Animal Management Groups, i.e. groups of animals (generally) of the same species that are managed by the farm household as homogenous units in terms of feeding, confinement, and grazing. The presence of *redistribution units (RU)*, such as stables (night corrals), manure heaps and compost pits is recorded. In addition, the *Household (HH)* is defined as the labour supply and consumption unit, *Stock*, as temporary store for staple crops (cereals and pulses), crop residues (for cattle feeding) and finally the 'external world' (EXT), consisting of markets, neighbours and/or other families, serving as a source of and/or destination for flows, that as externalities (not on-farm) are not monitored.

Quantifying nutrient flows

In the subsistence mixed crop-livestock farming system of Teghane, flows between the farm system and the external system/market (Figure 2, solid lines) and internal flows (Figure 2, broken lines) have been

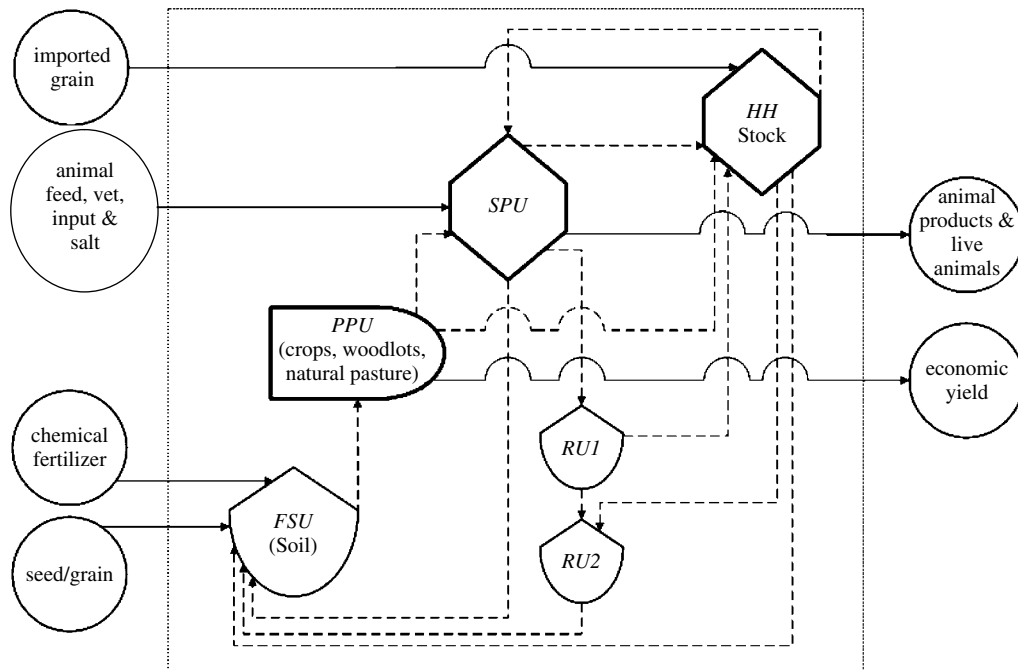

Figure 2. Inflows and outflows over the farm boundaries ('farm gate flows') (solid lines) and farm scale internal flows (broken lines).

schematized to quantify N, P and K inflows and outflows at both, field and farm scale. The external system/market is the source of inputs into the farm, i.e. chemical fertilizer and grain/seeds to the soil sub-system, animal feed (grass, crop residues and salt) and veterinary input to the secondary production sub-system, and food grains (food aid) to the household. Flows out of the farm consist of sales of economic yield from the crop component and animal products and live animals from the livestock component.

Internal flows within the farm consist of nutrient supply from the soil sub-system to Primary Production Units (crop, woodlot and grass/roughage), crop residues, grass and prickly pear leaves from the Primary Production Units to the Secondary Production Unit and grains and prickly pear fruits to the Household. The Secondary Production Unit supplies manure to the soil and the stable, animal products as food to the Household and animal dung for household fuel. Manure is transferred from the stable (RU1) to the compost pit (RU2), from where compost is transported to the crop land. Woodlots supply wood to the Household for fuel. Household waste is swept into the compost pit.

Using the NUTMON-toolbox, the quantities of nutrients entering and leaving the system components have been estimated and the balances (= inputs – outputs) for N, P and K are calculated for: (i) the farm scale, (ii) the field scale (PPU) (aggregation of all PPU's and iii) individual PPU's. Five PPU's have been distinguished, i.e., barley, wheat, faba bean and pea and natural pasture. Economic yield and removed residues/weeds from each field were estimated by sampling two to three quadrats of 3 × 3 metres along a diagonal within each field. Economic product and crop residues/weeds were separated and composite samples collected for laboratory analysis in the National Soil Research Center (NSRC), Addis Ababa to determine NPK contents. N removal from faba bean and pea fields was estimated at 50% of the total N content of harvested products (haulms and grain), assuming that the remaining N originates from biological fixation. 'Hard-to-quantify' nutrient inputs via atmospheric deposition and sedimentation and outputs via leaching, denitrification and erosion were not considered in this study, (iv) the SPU scale.

The quantities of N, P and K in the manure deposited in the stable were calculated from the number, type and confinement period of the animals in the stable, and the composition of the manure. Manure used for household energy was estimated as the average value of monthly weightings for eight months. Nutrients in

manure added to the compost pit/heap were estimated from daily measurements of the quantities of manure transferred from stable to compost pit/heap. Nutrients in refused fodder and household waste were calculated in NUTMON. During the dry season, immediately after harvest, livestock freely graze crop residues. In the wet season and when arable fields are cropped, animals graze natural pastures. Nutrients ingested by the animals and deposited in manure in the same fields were calculated from the length of the grazing period, assuming ad-lib feed intake. Nutrient flows from Primary Production Units to livestock were calculated from crop residue production, and other forms of feed/weeds for livestock and their NPK contents.

Nutrients transported from the woodlot for household energy were calculated from measured quantities of wood harvested and its nutrient content. Nutrient flows from Primary Production Units to stock/household were calculated from economic yields and their nutrient contents.

From each *FSU*, composite soil samples from the 0–20 cm surface layer were collected for laboratory determination of OC (Walkley and Black, 1947), available P (Olsen et al., 1954), total N (Bremner and Mulvaney, 1982) and total K (Knudsen et al., 1982) at the International Livestock Research Institute (ILRI), Addis Ababa and soil bulk density in the soils laboratory of Mekelle University.

Statistical analysis

Data on farm scale inflows, outflows and balances per farm group were subjected to analysis of variance using SPSS (SPSS, 2001).

Results

Agriculture in the Northern Highlands of Ethiopia

Agriculture in the Northern Highlands of Ethiopia has a very long history, in which schematically four stages can be distinguished in terms of farm management practices.

Stage I. In the early stage, the agricultural system was supported by indigenous soil fertility. The prevailing farming system was that of shifting cultivation, whereby areas were cleared of trees and the remaining materials burned to add ash to the soil. After some years of cultivation, the plots were abandoned for

Table 1. Organic carbon (OC), total nitrogen (TN), total P, available P (P-Olsen) and total K contents of the surface soil (0–20 cm) per farm group.

Farm group	OC (%)	TN (%)	Total P (ppm)	P-Olsen (ppm)	Total K (ppm)
Rich	2.89	0.26	567.5	26.0	5372
Medium	1.95	0.17	500.2	19.3	4036
Poor	1.17	0.12	544.9	9.1	4311

regeneration and new sites opened. As long as population densities were low, these systems were sustainable (Nye and Greenland, 1960). With increasing population pressure, the farming system gradually developed into a sedentary system with continuous cropping.

Stage II. In the sedentary farming system, characterized by continuous and intensive cropping, soil fertility rapidly declined, and so did crop yields (Bationo et al., 1998). In response, land management was modified to a system in which a proportion of the land was fallowed, allowing the natural vegetation to return and regenerate natural soil fertility. According to experts in local farming practices, use of long fallow periods greatly contributed to sustained agricultural production until about five decades ago. This was possible, because (i) sufficient arable land was available, and fallow periods of over three years could be maintained, (ii) demand for agricultural produce to feed a slowly growing population with low living costs was relatively low. However, accelerated population increase led to breakdown of this system, so that continuous cultivation became common practice and with it soil fertility decline.

Stage III. Continuous cultivation, with crop rotation was introduced as a management system to maintain favorable soil conditions and satisfactory yields. In these rotations, a grain crop (wheat or barley) was often grown the first year, followed by a legume crop (faba bean or field pea) in the second year and a grain crop (barley or wheat) in the third year, and 1–2 years of fallowing after 5–7 years of continuous cultivation.

Stage IV. Recently, rapid population increase, which has resulted in very small holdings, has changed the situation. All the land, including marginal lands, which are heavily degraded and eroded, is used for rainfed cultivation with a rotation of 4–5 years of cereal crops, followed by a leguminous crop. Fallowing has almost completely been abandoned, much of the animal manure is used for household energy, all crop residues are collected from the field for livestock, and grazing lands are excessively overstocked. Levels of

external inputs in the form of inorganic fertilizer and/or animal feed are very low. Thus, soil nutrients are rapidly depleted.

Farm scale analysis

Stocks and soil nutrient flows

Soil nutrient stocks per farm were defined as the total quantities of the macro-nutrients present in the top 20 cm of the soil profile, from where crops usually take up the major part of the nutrients (Van den Bosch et al., 1998; De Jager et al., 1998). These stocks include dissolved ions, nutrients in organic matter, adsorbed to the solid phase or in stable inorganic components. To assess the size of these stocks per farm for the macro-nutrients NPK, between 10 and 25 samples per farm have been analysed, depending on farm size and heterogeneity of its soils (Table 1).

Total biomass production and nutrient removal (both in absolute and relative terms) were higher from soils with higher total nitrogen contents (Table 2). Relative depletion rates were highest for N for all farm groups (but with varying rates, i.e., 1.5% for the rich, and 0.6% for both the medium and poor groups), followed by K and lowest for P for the medium and poor groups, whereas for rich farms, rates for P and K were the same.

Table 2. Nutrient stocks to a depth of 20 cm, calculated with average soil bulk density of 1240 kg m⁻³, and rates of change in Teghane, Northern Highlands of Ethiopia, 2002.

	Rich	Medium	Poor
Total N stock (kg ha ⁻¹)	3998	2614	1845
N-flows (kg ha ⁻¹ yr ⁻¹)	-96.0	-24.9	-18.3
N-flows (% of stock yr ⁻¹)	-1.5	-0.6	-0.6
Total P-stock (kg ha ⁻¹)	869	769	836
P-flows (kg ha ⁻¹ yr ⁻¹)	-11.3	-4.9	-1.3
P-flows (% of stock yr ⁻¹)	-0.8	-0.4	-0.1
Total K-stock (kg ha ⁻¹)	8620	6206	6629
K-flows (kg ha ⁻¹ yr ⁻¹)	-110.5	-42.1	-25.6
K-flows (% of stock yr ⁻¹)	-0.8	-0.4	-0.2

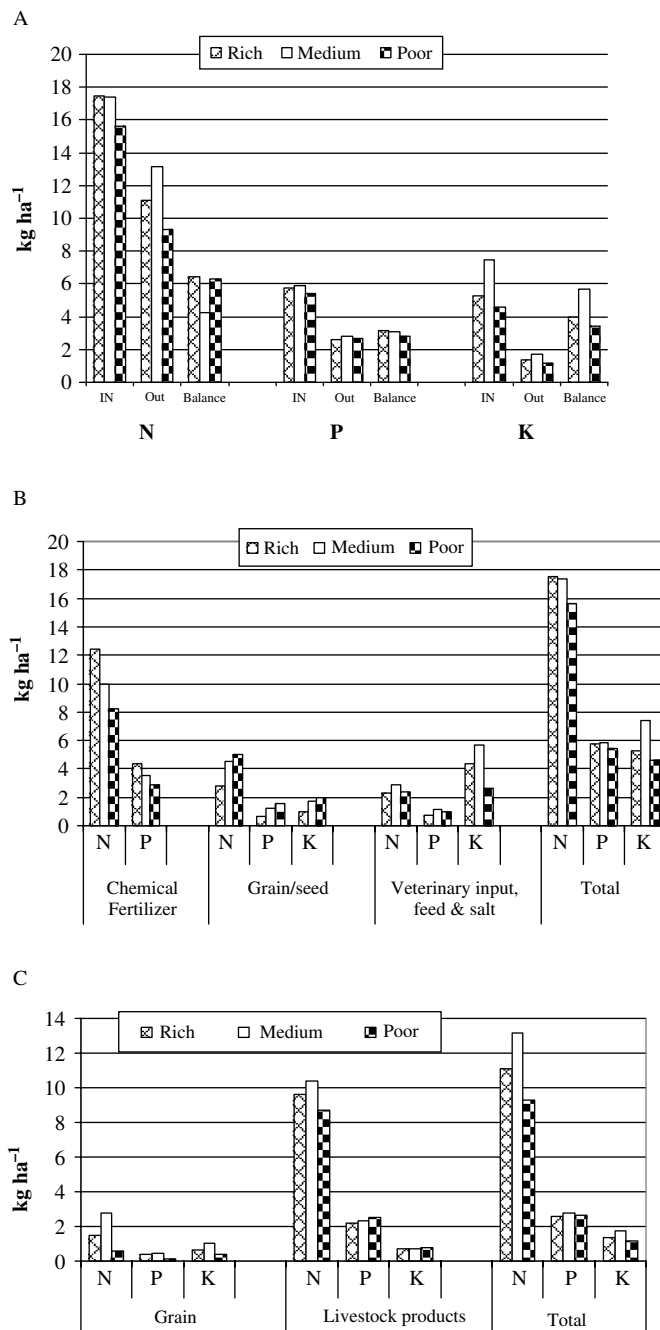

Figure 3. Farm gate NPK inflows, outflows and balances (A), inflows from external sources (B) and outflows to external destinations (C) (kg ha⁻¹ yr⁻¹) per farm group.

Farm gate balances

Farming in Teghane is characterized by subsistence farming systems with small land holdings, simple farm technology, and low yields. Farm scale NPK flow analysis (Figure 3A) indicates that although the quantities

of both exported and imported nutrients are small, imported nutrients from external sources into the farm are higher than nutrients exported to external destinations. Hence, for all farm groups the balances for all three macro-nutrients are positive, with higher values

for the rich farms than for the medium and the poor farms ($P < 0.05$).

Inflows

For all three farm groups, inflows into the farm (Figure 3B) include chemical fertilizer, veterinary products, animal feed and salt, purchased grain and other food items, plus external food aid in the form of food for work for medium and poor farmers. Inflows of the inorganic fertilizers urea and diammonium phosphate (DAP), restricted to irrigated fields, were very small, i.e. 12.5 kg N and 4.4 kg P ha⁻¹ for the rich; 10 kg N and 3.5 kg P ha⁻¹ for the medium; and 8.2 kg N and 2.9 kg P ha⁻¹ for the poor farm group, respectively.

Medium and poor farmers depended on external food aid, because grain production from their own fields was insufficient to meet the food requirements of the household. In total, 3 kg N, 0.9 kg P and 1.2 kg K ha⁻¹ for the medium group, and 4.4 kg N, 1.4 kg P and 1.8 kg K ha⁻¹ for the poor group, were imported in the form of wheat and sorghum. Rich farmers purchased 'teff' (*Eragrostis tef*) from the market, after selling barley or wheat from their stock and/or live animals.

Outflows

Farm scale outflows consisted of grain from stock, live animals and livestock products, i.e. eggs, skins and hides (Figure 3C), sold as a source of cash to buy chemical fertilizer, food items and clothing, for school fees and materials, and for land tax. For all farm groups, the highest outflows are through live animals and animal products.

Farm field analysis

Farm field here is defined as the 'aggregated' arable and natural pasture fields. In the following sub-sections (balances and flows) balances and flows are analyzed based on inputs 'into' and outputs 'from' cultivated fields and natural pastures, taking into account both external and internal transfers of NPK.

Balances

The balances of N, P and K showed negative values for all three farm groups (Figure 4), with higher values for the rich than for the medium and the poor farms ($p < 0.05$). The major causes of these high rates

of nutrient mining are very small land holdings, large families, large herds (with cattle dung mainly used for fuel) and very limited external inputs. Land is a very scarce resource with average holdings of 1.5, 0.8 and 0.5 ha per household, for the rich, the medium and the poor, respectively and household sizes of eight members for the rich, six for the medium and four for the poor. Average herd sizes are large in relation to the available grazing resources, i.e., 13 TLU¹ ha⁻¹ of grazing land for the rich, 7.3 TLU ha⁻¹ for the medium and 15 TLU ha⁻¹ for the poor.

Flows

Inflows of N, P and K were higher for the rich farms than for the medium and the poor ($P < 0.05$). In all farm groups, inflows of nutrients into farm fields originated partly from internal transfers (IN2), comprising compost, animal excreta voided during grazing and grain/seeds from stock, and partly from external sources (IN1), i.e. purchased inorganic fertilizer and seeds. Internal transfers accounted for more than 90% of the total inflows for all wealth groups, however with vastly different absolute rates: 112.4, 14.7 and 119.8 kg ha⁻¹ for N, P and K for the rich, 66.8, 10.1 and 69.9 kg ha⁻¹ for the medium and 62.3, 9.4 and 64.8 kg ha⁻¹ for the poor (Figure 5). Nutrient-saving techniques, such as soil and water conservation practices, were practiced more frequently by the rich group.

Animal excreta directly voided in the field provided the largest contribution for all farm groups (Figure 6): 93.6 kg N, 13.1 kg P and 107.2 kg K ha⁻¹ for the rich, 51.5 kg N, 9.2 kg P and 60.6 kg K ha⁻¹ for the medium and 48.7 kg N, 8.9 kg P and 54.9 kg K ha⁻¹ for the poor group. Chemical fertilizer (urea and DAP) contributed only 5.6–12% to the total inputs.

Outflows of N, P and K were higher for the rich farms than for the medium and the poor farms ($P < 0.05$). Removed crop products and animal feed (crop residues, grazed roughage/grass and removed weeds) comprised the main outflows of NPK from farm fields (Figure 7). In all fields of all farm groups, the largest outflow was through removal of grass/roughage and crop residues for animal feed.

¹TLU = Tropical Livestock Unit, a hypothetical animal of 250 kg liveweight, introduced as a common denominator for different animal types

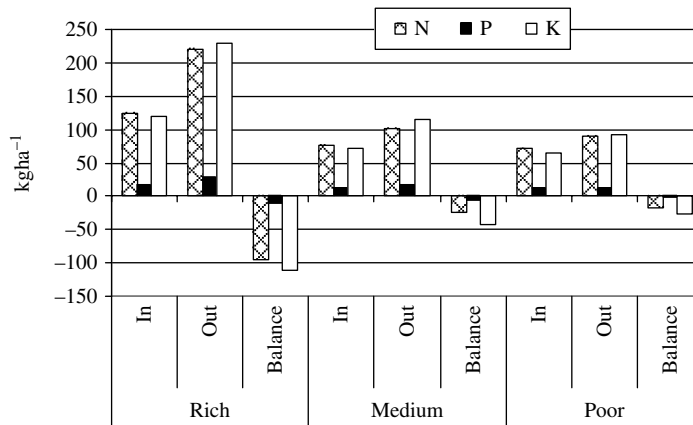

Figure 4. Partial NPK balances from farm fields per farm group (kg ha⁻¹ yr⁻¹).

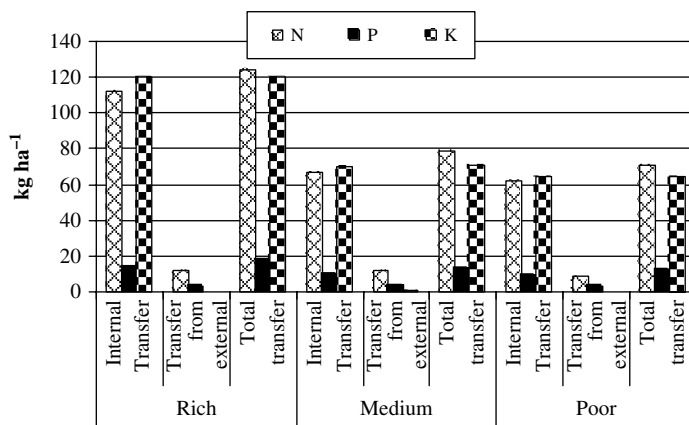

Figure 5. NPK transfers in farm fields per farm group (kg ha⁻¹ yr⁻¹).

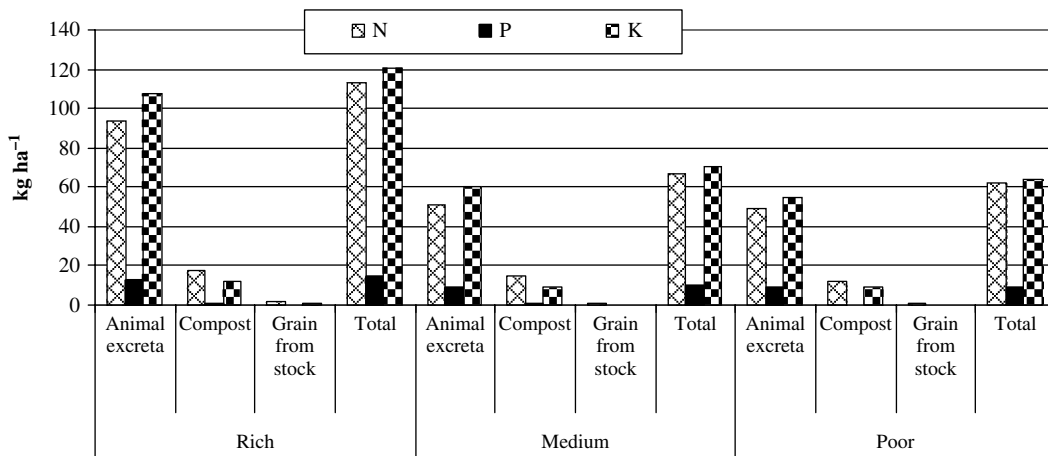

Figure 6. NPK internal transfers in farm fields per farm group (kg ha⁻¹ yr⁻¹).

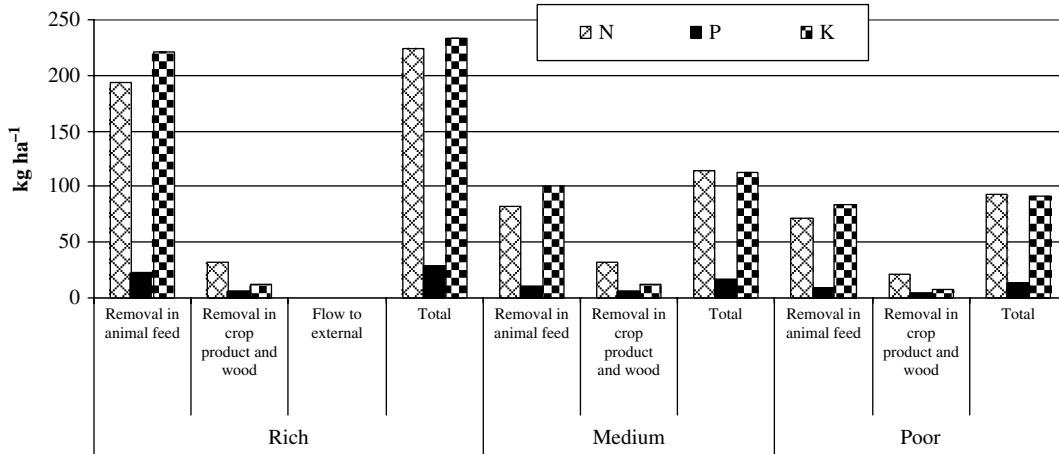

Figure 7. NPK removals from farm fields per farm group ($\text{kg ha}^{-1} \text{ yr}^{-1}$).

Field scale analysis/primary production units

Balances

The most important primary production units were barley, wheat, faba bean and pea and natural pasture. Grazing lands, including small pasture plots, borders of crop fields and areas around homesteads, are overgrazed and depletion rates were highest for all farm groups: -115 kg N , -5.8 kg P and $-112 \text{ kg K ha}^{-1}$ for the rich, -56.2 kg N , $-42.5 \text{ kg K ha}^{-1}$ for the medium and -56.5 kg N and $-34.6 \text{ kg K ha}^{-1}$ for the poor farms (Figure 8). For the latter two groups, P was almost in balance.

In barley fields, the highest negative balances were recorded for K: -112 kg ha^{-1} for the rich, -50.4 kg for the medium and -18.2 kg for the poor (Figure 8). The N balance was positive for the poor group (5.1 kg ha^{-1}) and negative for the rich (-81.9 kg ha^{-1}) and the medium groups (-8.7 kg ha^{-1}).

For wheat, all balances were negative for all farm groups (Figure 8). N balances for all fields were negative for the rich farm group with the lowest balance for faba bean and pea (-10.5 kg ha^{-1}). N balances for faba bean and pea were positive for the medium and poor farmers, with values of 4.0 and 20.3 kg ha^{-1} , respectively.

Flows

Stall-feeding is not practiced and nutrient outflows from grazing fields are through the removal of grass/roughage. During the dry season, March–July, a substantial proportion of the animals' ration consisted

of prickly pear leaves. The only input to the grazing fields was animal excreta voided during grazing. Women and children collect part of the cattle excreta from the fields for household energy in the dry season (October–June), so that only during the wet season all animal excreta remain in the field.

For barley fields, inputs consisted of compost, animal excreta, chemical fertilizer (in irrigated fields), and seed. For wheat, inputs included compost, animal excreta and seed. For faba bean and field pea, inputs consisted of compost, animal excreta, biological N fixation from the atmosphere, and seed. Removed grain, residues and weeds were sources of nutrient outflows from fields.

Significant quantities of the manure collected in the stable were used for household energy (Figure 9). The physical state of the stables and manure management in the stable led to some losses, i.e. 25.3 kg N , 5.8 kg P and $23.8 \text{ kg K ha}^{-1}$ for the rich group, 25 kg N , 5.5 kg P and 33 kg K ha^{-1} for the medium group and 8.8 kg N , 2.4 kg P and 8 kg K ha^{-1} for the poor group.

Compost is applied by spreading to the cultivated fields in the period from just after harvest (January) till sowing (end of June). The compost is not immediately incorporated in the soil, and, therefore, some of the N will be lost through volatilization. Compost is applied to cultivated land, irrespective of crop type, although, it was observed that fields with compost were mostly planted to barley and faba bean. As insufficient compost is available for all fields, some fields may not receive compost for three to five years.

All cattle, sheep, donkeys and chickens share the same stable at night. Stable floors consist of compacted

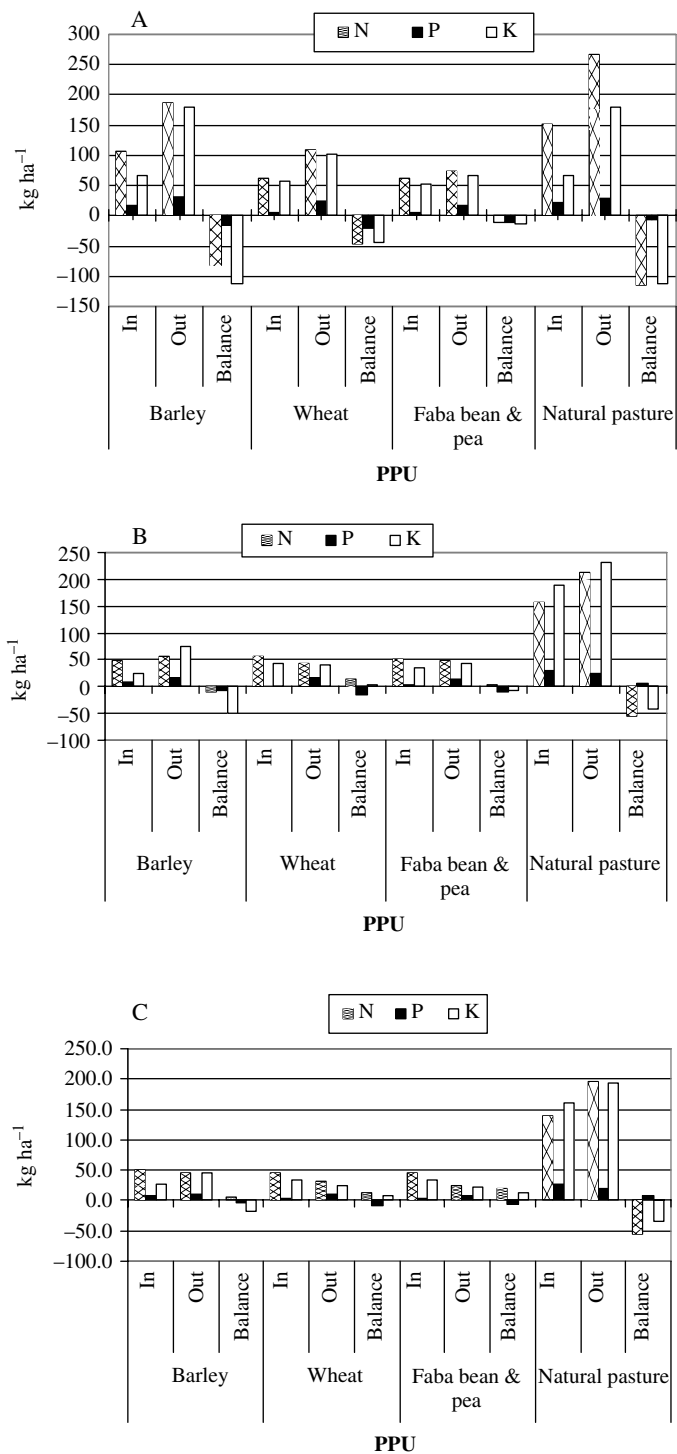

Figure 8. Average field scale NPK flows for rich farms (A), medium farms (B) and poor farms (C) kg ha⁻¹ yr⁻¹.

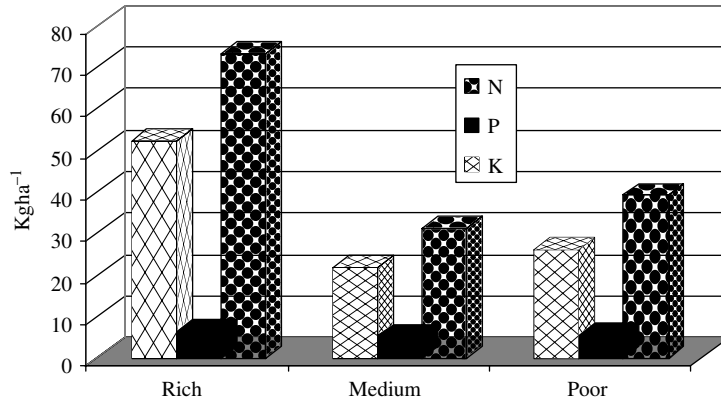

Figure 9. NPK contents of manure used for household energy per farm group ($\text{kg ha}^{-1} \text{ yr}^{-1}$).

soil, run under slope angles exceeding 10%, and have two to five urine drainage lines. Consequently, urine and manure do not mix, so that all nutrients in the urine are lost. Moreover, the stable is only partly covered, so that during the rainy season water flows through the accumulated manure and drains through the urine lines. Compost is stored in pits/heaps for long periods in the open, and after application to the field may again be exposed for extended periods before being worked in. This management leads to losses of the major part of the (inorganic) nitrogen from this material through volatilization and/or leaching.

Discussion and conclusions

In this study, the NUTMON software was applied to quantify and analyze nutrient flows and management at field and farm scale. Although the method performed satisfactorily for use at farm scale in Ethiopia, it needed some modification. First, in Ethiopia most of the manure from the livestock sub-system (stable and grazing fields) is transferred to the household subsystem of the farm as a source of household energy. This process was not captured in the NUTMON methodology. Second, NUTMON underestimates farm scale nutrient outflows in two ways: a) all nutrients transferred to household/stock and livestock from cultivated and grazed fields in the form of grain and residues/roughage are retained in the system without loss. In reality, almost all nutrients transferred to the household and part of the nutrients transferred to livestock are not recycled, as they are used for growth of animals and the household members and eventually will be exported out of the farm, b) flows of nutrients

out of the livestock sub-system through sales or when they die or are consumed by the household are not considered. Modifications in the size of the livestock sub-system (birth, death, sales, transferred and consumed) are only considered in the financial analysis.

Analyses at PPU and farming field scale of partial macro-nutrient (NPK) balances in Teghane, in the Northern Highlands of Ethiopia indicate that soil nutrient depletion proceeds at an alarming rate at both 'farm field' and plot scales. This soil mining is associated with increasing population pressure, which has led to very small land holdings. Thus, the only option for farmers is to exploit their farmland to the maximum to feed the family and the livestock, and satisfy household energy requirements as much as possible. Animal feed is extremely scarce and hence, every piece of crop organic matter, including roots and weeds, are collected from the farm fields at harvesting time (de Ridder et al., 2004). Moreover, from immediately after harvest till first ploughing, animals graze the cultivated land, so that hardly any plant remains are recycled in cultivated fields.

Nutrient depletion rates differ significantly among different farmer wealth groups. The highest rates were recorded for the rich farm group, followed by the medium and poor farm groups. These differences have two causes. First, chemical and physical soil fertility of the cultivated fields of the rich is generally higher. Secondly, they implement more frequently nutrient-saving techniques, such as soil and water conservation practices and apply more external and internal inputs. These farmers better prepare their land, seed on time, practice timely weeding, all of which require higher labor inputs. On the other hand, the low rates of depletion in the poor farm group are partly associated with low

crop production, due to low indigenous soil fertility, low inputs and poor crop management.

The results indicate that significant quantities of manure are used for household energy supply, equivalent to 52.3, 21.9 and 26 kg N ha⁻¹ yr⁻¹, respectively by rich, medium and poor farmers. In addition, due to inappropriate management of manure in the stable and the compost heap, significant losses take place, averaging 25.3 kg N, 5.8 kg P and 23.8 kg K ha⁻¹ year⁻¹ for the rich group, 25 kg N, 5.5 kg P and 33 kg K ha⁻¹ for the medium group, and 8.8 kg N, 2.4 kg P and 8 kg K ha⁻¹ for the poor group.

It may be concluded thus, that there is a need for development of integrated nutrient management systems. Two major processes restrict the efficiency of nutrient recycling through manure. First, a substantial proportion of the manure, both from the stable and from the grazing land is used for household energy. Although during burning, the major part of the nitrogen is lost, phosphorus and potassium are to a large extent retained in the ashes. However, for cultural reasons, only a small proportion of the ashes is recycled. Second, manure/compost management is far from optimal. Hence, improvements in nutrient use efficiency from manure could be attained through judicious manure management. First, it must be carefully stored to minimize physical loss of manure/compost, and its nutrients and it must be applied to the appropriate crop with the appropriate method at the proper time. Second, introduction of energy-saving stoves so that more manure, now used for household energy, can be applied to farming fields. On top of these, conditions should be created to make application of external inorganic fertilizer more attractive (Breman et al., 2001; Breman and Debrah, 2003). This could lead to application of more external chemical fertilizer in both irrigated and rainfed fields, combined with expansion of moisture harvesting for supplementary moisture supply.

Acknowledgments

The study was financed by the RESPONSE Project; 'Regional food security policies for natural resource management and sustainable economies', jointly run by Wageningen University and IFPRI in collaboration with Mekelle University (MU). We thank very much the farmers of Teghane who allowed us to collect extensive data from their farms which demanded sharing their time with us. We also thank our field assistants. Sincere thanks are due to Abebe Abay, National Soil

Research Laboratory Center, and Dawit Negasa, ILRI, both in Addis Ababa, Ethiopia, for laboratory analysis of plant and soil samples. Sincere thanks are also to Fokje Steenstra, Animal Production Systems Group, Wageningen University, for drawing of nutrient flow illustration.

References

- ADF (Africa Development Fund) 2002. The federal Democratic Republic of Ethiopia: Agricultural sector review. Agricultural and Rural Development Department, Addis Ababa.
- Atsbi World Vision 2004. Atsbi World Vision climatic data (2000–2004), Atsbi
- Bationo A., Lompo F. and Koala S. 1998. Research on nutrient flows and balances in West Africa: state-of-the-art. *Agric. Ecosyst. Environm.* 71: 19–35
- Bebe B.O. 2003. Herd dynamics of smallholder dairy in the Kenya highlands. Ph.D. Thesis. Wageningen University, Wageningen, The Netherlands .
- Belay T. 1992. Erosion: Its effect on properties and productivities of Eutric Nitosols in Gununo area, southern Ethiopia and some techniques of its control. African Studies Series A9. University of Bern, Bern, Switzerland.
- Block S.A. 1999. Agriculture and economic growth in Ethiopia: growth multipliers from a four-sector simulation model. *Agric. Econ.* 20: 241–252.
- Bojo J. and Cassels D. 1995. Land degradation and rehabilitation in Ethiopia: a reassessment. AFTES working paper No. 17, World Bank, Washington DC. 48 pp.
- Breman H. and Debrah K. 2003. Improving African food security. *SAIS Review* 23: 153–170.
- Breman H., Groot J.J.R. and van Keulen H. 2001. Resource limitations in Sahelian agriculture. *Global Env. Change* 11: 59–68.
- Bremner J.M. and Mulvaney C.S. 1982. Nitrogen-total. ANR analytical Lab, University of California. <http://groups.ucanr.org/danranlab/soil%5Fanalysis/>
- Constable M. 1984. Degradation of the Ethiopian highlands and action to combat it. Economic implications, costs and benefits. GAO/MOA joint project, EHRS report. Addis Ababa, Ethiopia.
- De Jager A., Nandwa S.M. and Okoth P.F. 1998. Monitoring nutrient flows and economic performance in African farming systems (NUTMON) I. Concepts and methodology. *Agric. Ecosyst. Environm.* 71: 37–48
- De Ridder N., Breman H., van Keulen H. and Stomph T.J. 2004. Revisiting a 'cure against land hunger': soil fertility management and farming systems dynamics in the West African Sahel. *Agric. Syst.* 80: 109–131.
- Elias E., Morse S. and Belshaw D.G.B. 1998. Nitrogen and phosphorus balances of kindo Koisha farms in southern Ethiopia. *Agric. Ecosyst. Environm.* 71: 93–113.
- FAO 1986. Highlands reclamation study. Ethiopia. Final report, Vol. 1. FAO, Rome, Italy. 334 pp.
- Harris F.M.A. 1998. Farm-level assessment of the nutrient balance in northern Nigeria. *Agric. Ecosyst. Environm.* 71: 201–214.
- Hengsdijk H., Meijerink G.W. and Mosugu M.E. 2005. Modeling the effect of three soil and water conservation practices in Tigray, Ethiopia. *Agric. Ecosyst. Environm.* 105: 29–40.

- Janssen B.H. 1999. Basics of budgets, buffers and balances of nutrients in relation to sustainability of agroecosystems. In: Smaling E.M.A., Oenema O., and Fresco L.O. (Eds.) *Nutrient Disequilibria in Agroecosystems*. CAB International, Wallingford, UK, pp. 27–56.
- Knudsen D., Peterson G.A. and Pratt P.F. 1982. Lithium, sodium and potassium. ANR analytical Lab, University of California. <http://groups.ucanr.org/danranlab/soil%5Fanalysis/>
- MOA (Ministry of Agriculture) 2002. A strategic plan for the sustainable development, conservation and management of the woody biomass resources. Vol. 5. Methodology, land use system analysis. Addis Ababa, Ethiopia.
- Mohamed Saleem M.A. 1998. Nutrient balance patterns in African livestock systems. *Agric. Ecosyst. Environm.* 71: 241–254.
- Nye P.H. and Greenland D.J. 1960. The soil under shifting cultivation. Commonwealth Bureau of Soils, Technological Communications No. 51, Harpenden, UK.
- Olsen S.R., Cole C.V., Watanabe F.S. and Dean L.A. 1954. Estimation of available phosphorus in soils by extraction with sodium bicarbonate. USDA Circular No. 939, USDA, Washington DC, USA.
- Paris Th. R. 2002. Crop-animal systems in Asia: Socio-economic benefits and impacts on rural livelihoods. *Agric. Syst.* 71: 147–168.
- Scoones I. and Toulmin C. 1998. Soil nutrient balances: What use for policy? *Agric. Ecosyst. Environm.* 71: 255–267
- Slingerland M. 2000. Mixed farming: Scope and constraints in West Africa savanna. Ph.D. Thesis. Wageningen University, Wageningen, The Netherlands.
- Smaling E.M.A. (Ed.) 1998. Nutrient balances as indicators of productivity and sustainability in Sub-Saharan African agriculture. *Agric. Ecosyst. Environm.* (Special issue) Vol. 71 (1,2,3). 346 pp.
- Smaling E.M.A., Von Uexkuell H.R. and Mutert E.W. 1993. The soil nutrient balance: an indicator of sustainable agriculture in Sub-Saharan Africa. Conference Proceedings, the Fertilizer Society. No. 340.
- SPSS (Statistical Package for the Social Sciences) 2001. Statistical Package for the Social Sciences. <http://www.spss.com>.
- Stoorvogel J.J. and Smaling E.M.A. 1990. Assessment of soil nutrient depletion in Sub-Saharan Africa: 1983–2000. Report 28, Winand Staring Centre, Wageningen, the Netherlands.
- Tellarini V. and Caporali F. 2000. An input/output methodology to evaluate farms as sustainable agroecosystems: An application of indicators for farms in central Italy. *Agric. Ecosyst. Environm.* 77: 111–123.
- Terry, E., 1999. Integrated Nutrient Management. Smallholders generally lack adequate nutrients for their crops. Agriculture Technology Notes No. 23, The World Bank, Washington
- Udo H.M.J. 2002. Use of ruminant livestock resources in resource-poor farming systems; back to the future: A view on current issues in livestock research and development. Animal Production Systems Group, Wageningen University and Research Centre, Wageningen, The Netherlands.
- UN 2002. United Nations Emergencies Unit for Ethiopia. Addis Ababa, Ethiopia. http://www.sas.upenn.edu/African_Studies/eue_web/eue_mnu.htm (consulted in April 2005)
- UNDP 2002. UNDP assistance in the 5th country program to the agricultural sector. http://www.sas.upenn.edu/African_Studies/eue_web/undp_p1.htm#top (consulted in January 2005)
- UNEP 2002. Ethiopia: National progress report submitted to the third series of sub-regional workshops (2003/2004), African regional workshop, 16–18 January 2002. <http://www.unep.ch/biosafety/development/countryreports/ETprogressrep.pdf> (consulted in April 2005).
- Van den Bosch H., De Jager A. and Vlaming J. 1998. Monitoring nutrient flows and economic performance in African farming systems (NUTMON). II. Tool development. *Agric. Ecosyst. Environm.* 71: 49–62.
- Van den Bosch H., Vlaming J., Van Wijk M.S., De Jager A., Bannink A. and Van Keulen H. 2001. Manual to the NUTMON Methodology. Alterra/LEI, Wageningen University and Research centre, Wageningen, The Netherlands.
- Van der Pol F. 1992. Soil mining – An unseen contributor to farm income in Southern Mali. Bulletin 325, Royal Tropical Institute, Amsterdam, the Netherlands.
- Viner D. 2003. The climatic impacts links project. High-resolution girded datasets. <http://www.cru.uea.ac.uk/cru/data/hrg.htm> (consulted in February 2005).
- Walkley A. and Black I.A. 1947. Estimation of soil organic carbon by the chromic acid digestion method. *Soil Sci.* 63: 251–264.

Nitrogen-15 Recovery in Cropped Soil Cores Fertilized With Potassium Nitrate and Clover Residues

Anne W. Muriuki^{1*}, Larry D. King², and Richard J. Volk²

¹ Kenya Agricultural Research Institute, National Horticultural Research Center, P.O Box 220-01000 Thika, Kenya, Tel: 254 067 21284, Fax 254 020 21282. Email: annewmuriuki@yahoo.co.uk; ² Department of Soil Science, North Carolina State University, NC 27695-7619;

Correspondence for Proofs: Dr Anne Muriuki, Kenya Agricultural Research Institute, National Horticultural Research Center, P.O Box 220-01000, Thika, Kenya.

Abstract

Although maize production in southeastern USA depends heavily on fertilizers, concerns over NO_3^- leaching have renewed interest in green manure legumes. Soil cores were extracted from a clayey, kaolinitic thermic Typic Kanhap-ludult in the North Carolina Piedmont in 1996 and fertilizer (K^{15}NO_3), $^{15}\text{N}^-$ enriched clover (*Trifolium incarnatum* L.) and no N (control) applied in 1997. Nitrogen movement in the soil/plant system was monitored 1997 and 1998. Clover residues mineralized rapidly (70% within 6 wk), treatments affected dry matter accumulation in maize in 1997 only, and total N content in vegetation (maize + weeds) was not affected any year. Treatments did not affect recovery of applied N in vegetation in 1997, but in 1998, more clover than fertilizer N was recovered (3.4% vs. 1.0%). More clover than fertilizer N was recovered in the organic (86.7% vs. 34.3%) and inorganic (3.6% vs. 1.8%) soil N pools in 1997 and in the organic soil N pool (91.3 vs. 21.3%) in 1998. Within the surface 0–25 cm, more clover than fertilizer N remained as organic N in 1997 (clover = 65% vs. fertilizer = 18%) and 1998 (clover = 70% vs. fertilizer = 14%), thereby underscoring the importance of green manure legumes in maintenance of long term soil fertility. Nitrate leaching (~1 m depth) was negligible both years; therefore higher loading rates can be applied to this soil. More fertilizer N and more clover N was recovered in the initial year of this study than reported previously for southeastern USA

Key words: Maize, fertilizer, green manure, leaching, ^{15}N

Introduction

Maize (*Zea mays* L.) is the second most important crop after wheat in USA, covering some 60 M ha (USDA 1990). Nitrogen fertilizers are routinely applied to maximize production, but a major concern is the potential for NO_3^- leaching, because large amounts of this N species (between 40 and > 150 kg ha⁻¹) remain in the surface 0–1.2 m soil (40 and > 150 kg ha⁻¹) after crop harvest, even without excess N fertilizer application (Magdoff 1991). A growing concern over excessive use of N fertilizers in North America has been

reported over the years (Newbould 1989; Shaviv and Mikkelsen 1993), and consequently, a renewed interest in green manure legumes (Hoyt and Hargrove 1986; King and Buchanan 1993; Crozier et al. 1998). Fertilizers are considered to be the main contributors to NO_3^- leaching (Germon 1989). However, incorporation of legumes with a low C:N ratio can also enhance leaching (Maidi et al. 1991; Drury et al. 1991; Azam et al. 1993) because they increase the ability of the soil to supply inorganic N (Sarrantonio and Scott 1988; Patra et al. 1992; Francis et al. 1994).

Studies involving fertilizer or legume N uptake by crops are best studied using ^{15}N . Recoveries from first year crops vary from < 20% to > 50 % from N fertilizer sources (Timmons and Cruse 1990; Varvel and Peterson 1990; Crozier et al. 1998) and from < 5% to > 30% from legume N sources (Azam et al. 1986; Ladd and Amato 1986; Varco et. al. 1989; Harris and Hesterman 1990). Crozier et al. (1998) investigated whether N form affected recovery of applied N in a long-term cropping systems study in southeastern USA. Recovery in maize + soil (0–30 cm soil depth) after one maize crop was 38% from $^{15}\text{NH}_4^+$, 44% from $^{15}\text{NO}_3^-$ and 44% from ^{15}N labeled legume clover residues. Since losses can be reduced to < 25% in well managed studies (Ladd and Amato 1986), we hypothesized that N movement was occurring below the surface 30 cm. Other losses could have occurred through volatilization and denitrification (Brady and Weil 1996), but volatilization was assumed to be negligible because soil pH was < 7. To monitor N movement more closely in that soil, we collected soil cores, applied ^{15}N from a fertilizer (K^{15}NO_3) and a ^{15}N -labeled crimson clover source, and monitored N movement in soil and percolate and uptake in maize over two growing seasons. Our objectives were to investigate whether (1) N leaching was occurring below the surface 30 cm soil (2) if greater recoveries were possible with increased depth of soil sampling and (3) to monitor N uptake in maize.

Material and methods

Lysimeters

Fifteen soil cores were collected in 1996 from a Cecil sandy clay loam (clayey, kaolinitic thermic Typic Kanhapludult) in the North Carolina Piedmont by pressing polyvinyl chloride (PVC) pipes (60 cm outside diameter x 120 m long) into the soil using a tractor-mounted press. The Ap horizon had 47% sand, 21% silt, 32% clay, pH 6.3, total N, 860 mg kg^{-1} and total C 14.4 g kg^{-1} . The pipes were beveled on the inside and outside to facilitate good contact between pipe and soil and the area irrigated to facilitate pressing. The pipes were pressed using a hydraulic press mounted from a tractor. (Fig. 1) as deep as possible and the soil surrounding 75% of the pipe removed. Then a PVC plate (66cm by 66cm by 1.2cm) was beveled on the advancing edge and pressed tightly against the bottom end of the core using a guide bracket and a portable hydraulic cylinder driven from the remote hydraulic system of a tractor (Fig. 2). A steel plate (61.6cm by 60cm by 0.9cm) with a lifting

eye was placed on top of each lysimeter and four steel rods (1.7cm diameter by 134.4cm) threaded between the bottom plate and steel plate. Lysimeters were lifted with a backhoe and transported to a permanent site at the Department of Biological and Agricultural Engineering, North Carolina State University. Twelve cores were selected for the experiment after irrigating with 181 mm and a randomized complete block design applied based on the ease of drainage (Muriuki 2000).

Production of ^{15}N -labeled crimson clover

Tibee crimson clover (*Trifolium incarnatum* L) was planted in sand culture contained in bins (78 cm by 49 cm by 25 cm) in a greenhouse at North Carolina State University on 3 March 1997 and watered with distilled water until germination was complete (~1 wk). A Hoagland solution (Hoagland and Arnon 1950) containing 5mM K^{15}NO_3 (60.555 atom % ^{15}N) was applied twice weekly to supply nutrients and label the clover with ^{15}N . Unlabeled clover was grown in bins, and watered with a Hoagland solution containing unlabeled KNO_3 . After thinning clover plants at 10 and 64 d after sowing, the remaining plants were harvested whole (shoots + roots) on May 15 (73 d), just before they reached full bloom. Roots were washed thoroughly with running water to remove sand particles, cut (0.5–1.0 cm) and dried (65°C) for 2d. A sub sample was analyzed for total C and N on Perkin Elmer 2400 CHN elemental Analyzer (Perkin-Elmer Corp. Norway, CT).

Treatments

Three treatments were applied on June 2 1997, and replicated three times: fertilizer- N (83 kg N ha^{-1}), clover- N (81 kg N ha^{-1}) and no N (control). Clover residues (380 g carbon kg^{-1} , 40.255 atom % ^{15}N , 25.4 g N kg^{-1}) were incorporated into the upper 15 cm of soil, while fertilizer- N was supplied by a 0.17 M K^{15}NO_3 solution containing 60.921 atom % ^{15}N in two splits (2 June and 11 August, 1997). Maize was planted on June 24 1997 (B73 purple x NC296A) and May 8 1998 (7706 x 7705 KU2301) at a rate of 17 seed m^{-2} and thinned to seven seeds m^{-2} on July 11 in 1997 and June 6 in 1998. Stalk borer was controlled with Furadan –156 (3.4 g m^{-2}) in 1998. Supplemental irrigation (Fig. 3), was applied whenever drought stress caused maize to begin curling by 9 a.m. Maize was harvested on 31 October in 1997 and 5 October in 1998. Shoots (stovers + cobs + grain) were cut to 20–30 cm and

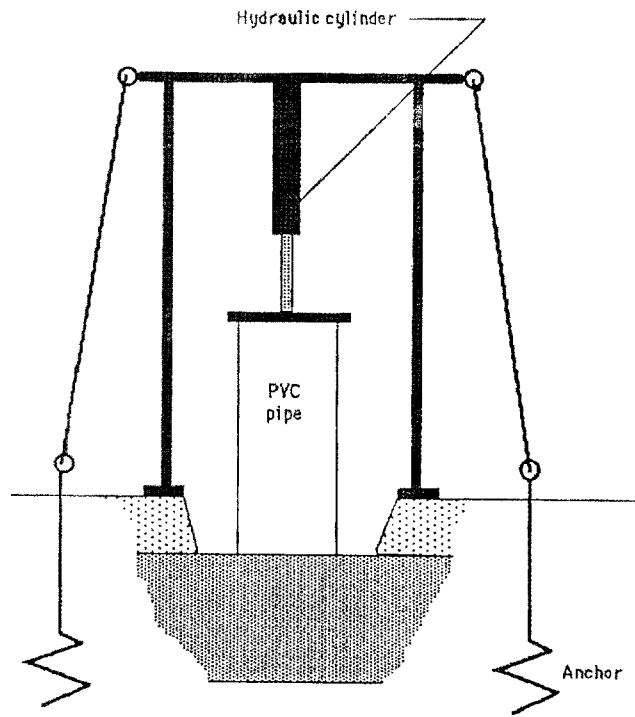

Figure 1. Tractor mounted press used to force pipe into soil.

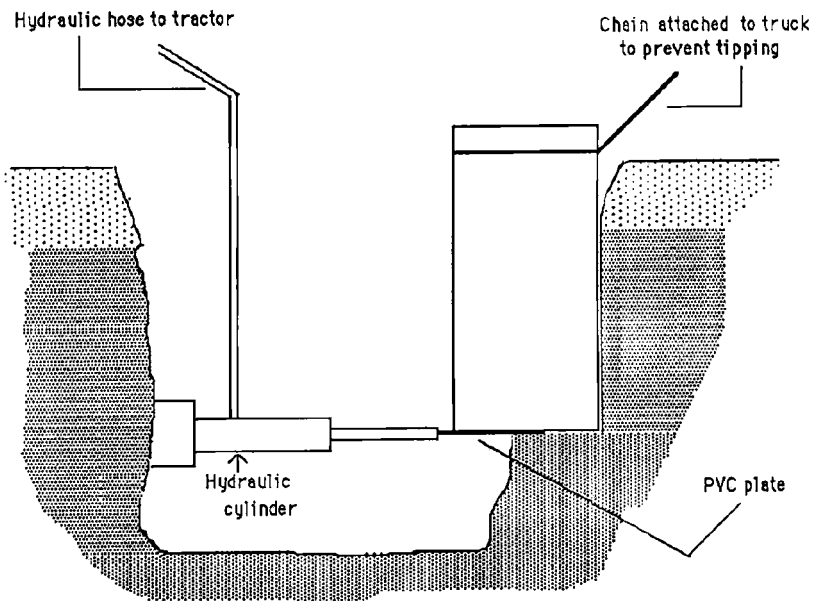

Figure 2. Tractor mounted hydraulic cylinder used for installation of PVC plate at bottom of pipe.

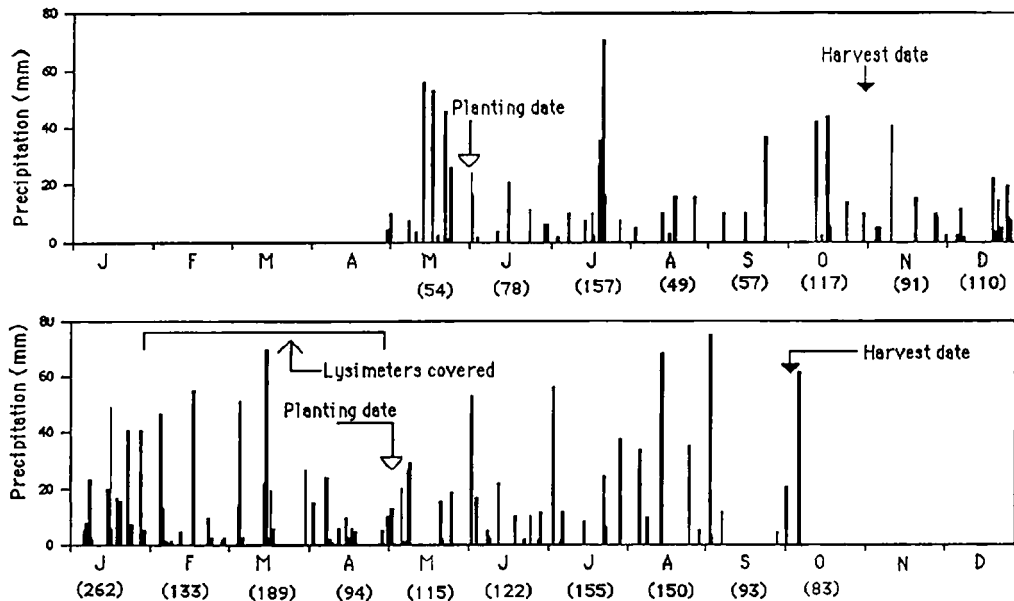

Figure 3. Precipitation during maize growing seasons. Monthly totals are shown in parentheses.

the roots carefully extracted and washed thoroughly in running water. Then all material was dried (65°C) for 3 d, ground (< 1 mm) and stored in plastic vials prior to analyses. Weeds were removed whole by hand, on 11 July, 9 August, and 31 October in 1997 and 3 May, 9 June, 21 July, and 5 October in 1998. After washing in running water to remove soil, they were dried (65°C) for 3 d, ground (Tecator Cyclotec 1093), and stored in plastic vials prior to analyses. All dry matter calculations were made on an area basis.

Soil sampling protocol

Soil samples were collected after each maize harvest, from 0–25 cm and 25–55 and 55–85 cm soil depth using a 2.54-cm diameter probe, bulked, then air dried and sieved to < 2 mm. Percolate draining from ~1m soil depth was collected whenever the volume reached 1.2 to 2.2 L and measured. Sub-samples (~50 ml) were stored frozen until analyses of inorganic N. A portion of the remaining sample was used to concentrate NO₃⁻ for ratio-isotope analyses.

Clover decomposition

Clover decomposition was determined by the litter bag technique. Twelve samples of cut (0.5–1.0 cm) unlabeled crimson clover residues (28 g N kg⁻¹) weighing

~4.5 g were placed into 15 cm by 15 cm nylon mesh bags with 1.5 mm by 1.5 mm openings. A color marker string was attached to ease retrieval. The bags were buried horizontally 15 cm deep, in one core separate from other treatments. Three bags were removed after 4, 8 and 12 wk, dried (65°C for 2 d) and the soil carefully removed. After weighing and grinding (Tecator Cyclotec 1093 sample mill) samples were stored in plastic vials prior to analyses of total N by Kjeldahl digestion (Bremner and Mulvaney 1982). Dry weights were determined after burning a sub-sample to ash in a muffle furnace at 500°C for 6 h. Decomposition was described using the regression model after Wilson and Hargrove (1986) as described in equation 1.

$$NR_t = R + [(100 - R)e^{-kt}] \quad (1)$$

where NR_t is the percent of initial N recovered at time t, R is the percentage of tissue N resistant to decomposition, k is the decomposition rate constant (wk⁻¹) and t is time (wk).

Laboratory analyses

Sixty- or 70- g of air dry soil (< 2mm) was extracted with 0.5M K₂SO₄ (1:3 soil solution ratio) by shaking and subsequent centrifugation. The supernatant was retained for total inorganic N (NO₃⁻, NO₂⁻, NH₄⁺) determination by steam distillation methods (Keeny

and Nelson 1982) and the residue dried for 2–3 wk before determination of organic N in a 3- or 4- g sub sample by the micro-Kjeldahl procedure (Bremner and Mulvaney 1982). Total N in maize and weeds was determined by the micro-Kjeldahl procedure (Bremner and Mulvaney 1982). Inorganic N in percolate samples (NH_4^+ , $\text{NO}_2^- + \text{NO}_3^-$) was determined by automatic colorimetric procedures using Lachat auto-analyzer. Preparation of percolate samples for ratio isotope analyses involved evaporation (150°C) of 1L sub-samples until the volume could be contained in a 12-mm by 75-mm borosilicate test tube. One ml of 1 M KOH was added to the test tubes prior to evaporation to trap NO_3^- . Trapping solutions were evaporated to dryness on a Savant vacuum centrifuge evaporator.

The ^{15}N enrichment of total N in plant material (maize, weeds and clover) and organic N in soil samples was determined from samples containing $\sim 0.4\text{g N}$, following a modification of the diffusion procedure (Mackown et al. 1987), described by Muriuki et al. (2001) and for total inorganic N, from samples containing $\sim 0.4\text{g N}$ following a modification of the diffusion procedure (Brooks et al. 1989) described by Muriuki et al. (2001). All ratio isotope ratio analyses were performed using a CEC 21 620 mass spectrometer (Consolidated Electrodynamics Corp., Pasadena, CA) after converting NH_4^+ to N_2 gas by the NaOBr freeze layer technique (Volk and Jackson 1979) and NO_3^- to NO (Volk et al. 1979). Computations for recovery of ^{15}N were made following the calculations of Hauck and Bremner (1976).

Statistical analyses

All data was subjected to analyses of variance (ANOVA) using the general linear model procedure (SAS Institute Inc. 1989) and comparisons made by protected LSD tests.

Results and discussion

Decomposition of clover residues

Initially, total N disappeared rapidly from decomposing clover residues (Fig. 4), in response to their low C:N ratio (15:1). Of the 25 g N kg^{-1} N initially present, 35% had mineralized within 2 wk and 70% by 6 wk. By 12 wk, we found only 16% of the N initially present. Ranells and Waggoner (1992) and Crozier et al. (1994)

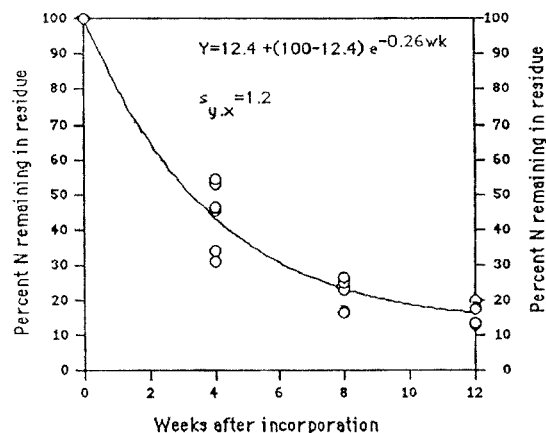

Figure 4. Disappearance of clover N during decomposition of residues.

found a similar pattern of clover N disappearance during decomposition of buried clover residues in other southeastern USA field studies. The pattern has been interpreted to represent the decomposition of labile N first, followed by decomposition of more recalcitrant fractions (Watkins and Barraclough 1996).

Dry matter production and plant N uptake

Dry matter accumulation in maize was greater with fertilizer than with clover and control treatments in 1997 only (Fig. 5). Dry matter accumulation in weeds did not differ amongst treatments any year (data not shown) and treatments did not affect the total N content of maize shoots any year (Fig. 6) or the total N content of weeds (data not shown). Total N content of roots responded to treatments both years (1997: fertilizer > clover > control and 1998: clover > control) and was related to dry matter accumulation in 1997 (Fig. 5 and 6). Nitrogen concentration was not affected by treatments any year (data not shown). Clover residues mineralized rapidly (Fig. 4), but maize roots took up less N with clover than with fertilizer treatments in 1997 (Fig. 6), presumably because clover decomposition occurred under anaerobic conditions following the heavy rainfall events of June 3 to 6, 1997 (Fig. 3). As a result, nitrification was presumably inhibited for a considerable period of time, and NH_4^+ accumulated instead. Since microorganisms take up NH_4^+ more readily than NO_3^- , (Jackson et al. 1989; Lekkerkerk et al. 1990; Ahlgren et al. 1994) microbial sequestration of NH_4^+ may have exceeded crop uptake, thereby reducing the enriched inorganic N pool available to

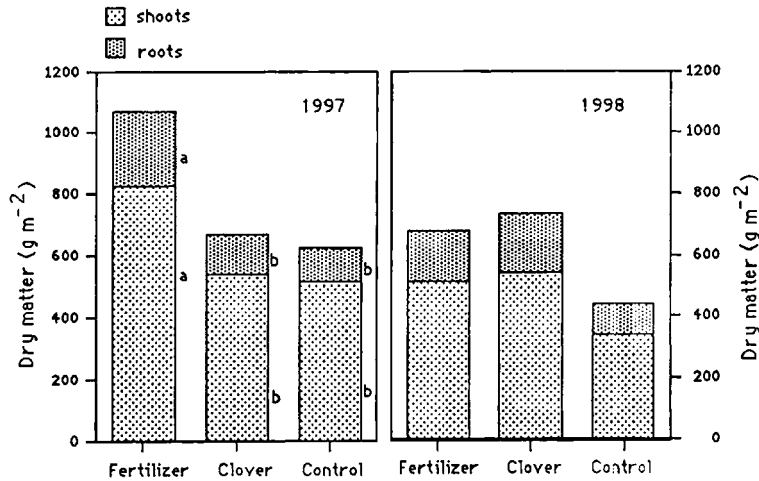

Figure 5. Maize dry matter in 1997 and 1998.

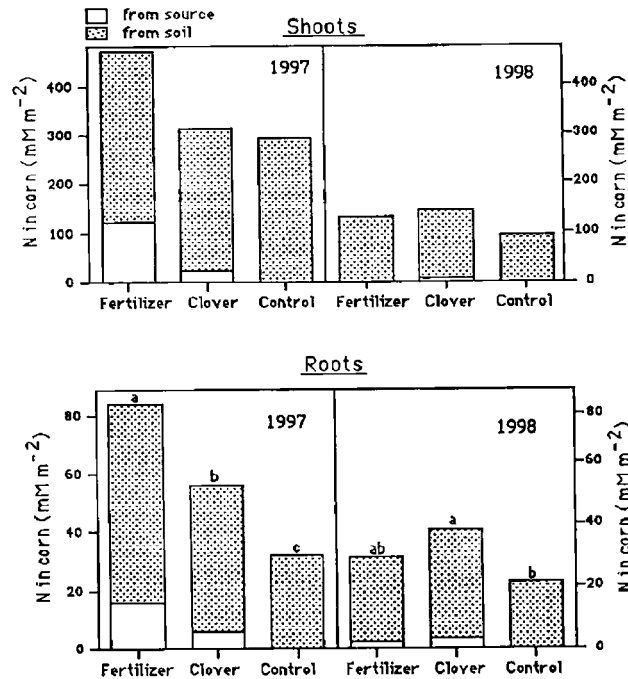

Figure 6. Effect of treatments on N content in maize.

maize. Microbial populations can temporarily immobilize inorganic N from legumes (Aulakh et al. 1991; Muriuki et al. 2001).

Effect of treatments on native soil N

Accumulation of N derived from soil in maize (shoots + roots) and weeds was similar among treatments both

years (data not shown), suggesting that an added nitrogen interaction (ANI) did not occur following N applications. So we subtracted the N derived from applied sources in plants and in soil from the total N in plants and total inorganic N in soil and compared it with N in the control. Total soil N (left in soil + in plants) in the inorganic pool was similar among treatments (Table 1), indicating that treatments did not affect mineralization of native soil N, and consequently, no ANI was

Table 1. Effect of treatments on accumulation of native soil inorganic N

Treatment	1997				1998			
	Shoots	Roots	Weeds	Soil	Shoots	Roots	Weeds	Soil
	mM N m ⁻²							
Fertilizer	349	68	176	523	126	27	112	191
Clover	289	50	133	501	136	35	139	177
Control	292	32	129	429	93	21	129	168
LSD_{0.05}	ns	17.6	ns	ns	ns	ns	ns	ns

found. We therefore presumed that mineralization of soil organic N had occurred similarly in all treatments, perhaps as a result of elevated temperatures during summer (Thiagalingam and Kameliaro, 1973; Binkley et al. 1994). Crozier et al. (1998), found N accumulation from enriched fertilizer and legume sources in maize to be small, and concluded that substantial mineralization of native organic N and inorganic N immobilization occurs in this soil.

Movement of applied N in the soil profile

In 1997, more applied N was recovered from the 0- to 25-cm soil layer in organic and inorganic soil N pools with clover than with fertilizer treatments, but not at lower depths (Fig. 7). The same trend was noted in 1998, for the organic N pool (Fig. 8). Ladd and Amato (1986) reported a similar trend for treatments supplied with legume N in a soil sampled to 90 cm depth. About

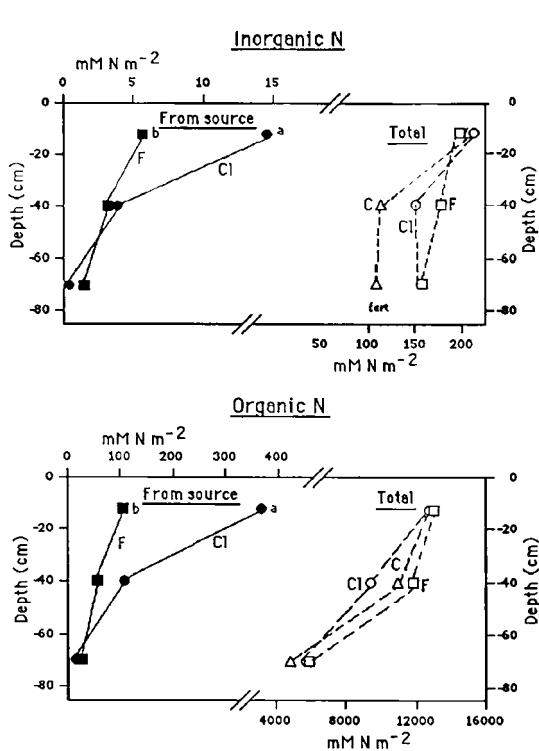

Figure 7. Total inorganic and organic N and amounts derived from applied sources in treatments supplied with fertilizer (F) or clover (Cl) N and no N © in 1997. Symbols followed by a different letter at the same depth are significantly different at the 5% level of probability.

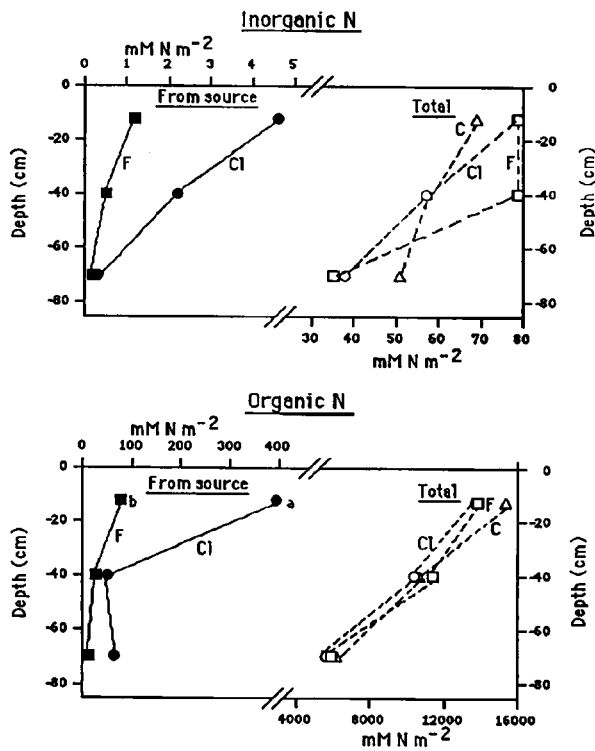

Figure 8. Total inorganic and organic N and amounts derived from applied sources in treatments supplied with fertilizer (F) or clover (Cl) N and no N (C) in 1998. Symbols followed by a different letter at the same depth are significantly different at the 5% level of probability.

Table 2. Recovery of applied N in various N pools

N Source	1997			1998		
	Fertilizer N	Clover	LSD	Fertilizer	Clover N	LSD
	% of applied N					
Soil organic N	33.6	86.7	49.2	21.3	91.3	27.7
Soil inorganic N	1.8	3.6	1.8	0.3	1.3	ns
Total soil N	34.4	90.3	49.8	21.7	92.6	27.2
Maize + weeds	25.2	10.4	ns	3.4	1.0	0.7
Maize shoots	21.3	4.7	ns	0.4	1.1	0.3
Maize roots	2.8	1.0	0.3	0.1	0.4	0.1
Weeds	1.2	4.6	ns	0.5	1.9	1.0
Leachate	<0.1	<0.1	ns	<0.1	<0.1	ns

one third of fertilizer N was immobilized into the soil organic pool in 1997: 0–25 cm, 18%; 25–55 cm, 10%; and 55–85 cm: 5% indicating that microbial immobilization of fertilizer N was not limited by availability of carbon. Most clover N remained in the organic form both years (Table 2) and was concentrated in the surface 25 cm (Fig. 7 and 8). Sixty-five percent of clover N was found in the surface 25 cm, but 19% moved into the soil layer below (25–55 cm). We suggest that the heavy precipitation (Fig. 1) received within the first 4d after incorporating clover in 1997 leached organic N from a labile pool residing within clover. This was confirmed after we extracted clover tissue with 0.5 M K₂SO₄ and found that 14% of the clover N was extracted as organic N and 21% as inorganic N (Muriuki, 2000). Analyses of NO₃⁻ in percolate showed minimal leaching loss over the entire period of the study (data not shown).

Recovery of applied N

Treatments did not affect uptake of applied N in vegetation (maize + weeds) in 1997, but maize roots took up more fertilizer than clover N (Table 2). Maize shoots tended to take up more fertilizer than clover N ($Pr > F = 0.11$) and weeds, more clover than fertilizer N ($Pr > F = 0.06$). In 1998, vegetation took up more clover (3.4%) than fertilizer N (1.0%) and more clover than fertilizer N ($P < 0.05$) was recovered in shoots (1.1% vs. 0.4%), roots (0.4 vs. 0.1%), and weeds (1.9% vs. 0.5%). Nitrate leached in percolate (~1m depth) was negligible both years (Table 2). Treatments did not affect total N found in the organic and inorganic soil pools either year (Fig. 7 and 8), but recovery of applied N in soil N pools was always greater with clover than

with fertilizer except for the inorganic N pool in 1998 (Table 2).

Like in our study, Crozier et al. (1998) reported that the source of N did not affect N recovery in a first year maize crop but recovery was greater from clover than from fertilizer in a second maize crop. In 1997, recovery of fertilizer-supplied N in vegetation i.e. shoots + roots + weeds (25.2%) was within the < 20% to 59% reported in published studies (Ladd and Amato 1986; Timmons and Cruze 1990; Varvel and Peterson 1990; Reddy and Reddy 1993; Harris et al. 1994). Similarly, recovery of clover N in vegetation (10.4%) was within the range of published values (2 to >30%) for a first year crop (Ladd and Amato 1986; Varco et al. 1989; Harris and Hesterman 1990; Jensen 1994). In 1998, fertilizer N recovered in vegetation (1.0%) was within the 1 to 3% range reported by others (Ladd and Amato 1986; Janzen et al. 1990; Harris et al. 1994; Crozier et al. 1998) and residual clover N recovery (3.4%) within the range (1–7%) of published values (Ladd and Amato 1986; Harris and Hesterman 1990; Harris et al. 1994; Crozier et al. 1998).

Weeds competed well for plant available N because they grew well early in the season (data not shown), mostly acting as a sink for mineralized clover N (Table 2), and thereby minimizing early season losses. Therefore, we propose that weed kill can be manipulated early in the season to release legume N to maize later in the season. House et al. (1984) outlined the importance of weeds as a store pool for the N that would be otherwise lost from the soil via denitrification, leaching or erosion. Groffman et al. (1987) also found N accumulation in weeds to be greater in treatments supplied with legume N than with fertilizer N.

Most applied N remained in the soil in the initial year of study and more of it was recovered with clover than

with fertilizer treatments. Others have reported similar findings with cover crops e.g. labeled *Medicago littoralis* vs. $^{15}\text{NO}_3^-$ (Ladd and Amato 1986), labeled crimson clover vs. $^{15}\text{NO}_3^-$, (Crozier et al. 1998) and labeled red clover vs. NH_4^+ (Harris et al. 1994). Like other legume green manure, most clover N remained in the organic form, thereby contributing to long-term soil fertility by building up soil organic N reserves (Azam et al. 1986; Ladd and Amato 1986; Harris et al. 1994).

Total recovery of applied N tended to be greater with clover than with fertilizer treatments (101% vs. 60% $P > F = 0.07$) in the initial year of this study. Some studies concur with this trend e.g. 84% of red clover N vs. 70% of fertilizer N (Harris et al. 1994), 94% from legume N vs. 60% from fertilizer N (Azam et al. 1986). Others show comparable recoveries between an organic and inorganic N source e.g. 44% from crimson clover vs. 44% from NO_3^- (Crozier et al. 1998), 83.3% from *Medicago littoralis* vs. 80.1% from NO_3^- , (Ladd and Amato 1986).

Conclusions

Because of its rapid decomposition rate and high N content, clover green manure can be used to meet some of the N requirements of maize from the time of emergence in southeastern USA. Persistence of clover N in soil underscored the importance of green manure legumes in building up soil organic N reserves, thereby maintaining long term soil fertility. Neither residual N from fertilizer or clover could meet the N requirements of a second maize crop, so fresh applications from either N source should be made each season. Nitrate leaching was negligible both years, indicating that it is safe to apply higher loading rates ($>80 \text{ kg N ha}^{-1}$) to this soil and more fertilizer and more clover N was recovered in the initial year of this study than previously reported for southeastern USA.

Acknowledgements

The authors are grateful to Dr RO Evans for technical support in extraction of soil cores and to Mr. M Barnes and Ms. Penny for technical support at various stages of the work. Our gratitude also goes to the Rockefeller Foundation for financing this research.

References

- Ahlgren I., Sorensson F., Waara T. and Verde K. 1994. N budgets in relation to microbial transformations in lakes. *Ambio*. 23: 376–377.
- Aulakh MS., Doran J.W. Walters D.T. Mosier A.R. and Francis D.D. 1991. Crop residue type and placement effects on denitrification and mineralization. *Soil Sci. Soc. Am. J.* 55: 1020–1025.
- Azam F., Malik K.A. and Sajjad M.I. 1986. Uptake by wheat plants and turnover within soil fractions of residual N from leguminous plant material and inorganic fertilizer. *Plant Soil* 96: 97–108.
- Azam F., Simmons F.W. and Mulvaney R.L. 1993. Mineralization of N from plant residues and its interaction with native soil N. *Soil Biol. Biochem.* 25: 1787–1792.
- Binkley D., Stottlemeyer R., Suarez F. and Cortina J. 1994. Soil N availability in some arctic ecosystems in northwest Alaska: responses to temperature and moisture. *Eco. Sci.* 1: 64–70.
- Brady N.C. and Weil R.R. 1996. The nature and properties of soils. 11th ed. Prentice Hall, upper Saddle, NJ. pp. 400–444.
- Bremner J.M. and Mulvaney C.S. 1982. Nitrogen: Total. In: Page A.L. (Ed.) *Methods of soil analyses, part 2, chemical and microbiological methods*. Agronomy monograph no. 9, 2nd ed. Soil Science Society America Inc., Madison. pp. 565–624.
- Brooks P.D., Stark J.M., McInteer B.B. and Preston J. 1989. Diffusion method to prepare soil extracts for automated nitrogen-15 analysis. *Soil Sci. Soc. Am. J.* 53: 1707–1711.
- Crozier C.R., King L.D. and Volk R.J. 1994. Tracing nitrogen movement in corn production systems in the North Carolina Piedmont: Analysis of nitrogen pool size. *Agron. J.* 86: 642–649.
- Crozier C.R., King L.D. and Volk R.J. 1998. Tracing N movement in maize production systems in the North Carolina Piedmont: A N-15 study. *Agron. J.* 90: 171–177.
- Drury C.F., Stone J.A. and Findlay W.I. 1991. Influence of cover crops on denitrification and nitrogen mineralization. In: Hargrove, W.I. (Ed.) *Cover crops for clean water*. pp. 94–96.
- Francis G.S., Hayes R.J. and Williams P.H. 1994. Nitrogen mineralization, nitrate leaching and crop growth after plowing in leguminous and non-leguminous grain crop residues. *J. Agric. Sci.* 123: 81–87.
- Germon J.C. 1989. Management systems to reduce impact of nitrogen. Elsevier UK.
- Groffman P.M., Hendrix P.F. and Crossley Jr. D.A., 1987. N dynamics in conventional and no-tillage agro-ecosystems with inorganic fertilizer or legume N inputs. *Plant Soil* 97: 315–332.
- Harris G.H. and Hesterman O.B. 1990. Quantifying the N contribution from alfalfa to soil and two succeeding crops using N-15. *Agron. J.* 82: 129–134.
- Harris G.H., Hesterman O.B., Paul E.A., Peters S.E. and Janke R.R. 1994. Fate of legume and fertilizer N-15 in a long term cropping systems experiment. *Agron. J.* 86: 910–915.
- Hauck R.D. and Bremner, J.M. 1976. Use of tracers for soil and fertilizer nitrogen research. *Adv. Agron.* 28: 219–266.
- Hoagland D.R. and Arnon, D.I. 1950. The water culture method for growing plants without soil. *California Agric. Exp. Station*. pp. 4–32.
- House G.J., Stinner B.R. and Crossley Jr. D.A. 1984. N cycling in conventional and no-tillage agro-ecosystems in the Southern Piedmont. *J. Soil Water Conserv.* 39: 194–200.

- Hoyt G.D. and Hargrove W.K. 1986. Legume cover crops for improving crop and soil management in the southeastern United States. *Hort. Sci.* 21: 397–402.
- Jackson L.E., Schimel J.P. and Firestone M.K. 1989. Short-term partitioning of ammonium and nitrate between plants and microbes in an annual grassland. *Soil Biol. Biochem.* 21: 409–415.
- Janzen H.H., Bole J.B., Biederbeck V.O. and Stinkard A.E. 1990. Fate of N applied as green manure or ammonium fertilizer to soil subsequently cropped with spring wheat at three sites in Western Canada. *Can. J. Soil Sci.* 70: 313–323.
- Jensen E.S. 1994. Availability of N in ¹⁵N-labeled mature pea stands to subsequent crops in the field. *Soil Biol. Biochem.* 26: 465–472.
- Keeny D.R. and Nelson D.W. 1982. Nitrogen: Inorganic forms. In: Page A.L. (Ed.) *Methods of soil analyses, part 2, chemical and microbiological methods*. Agronomy monograph no. 9 (2nd ed.) Soil Science Society America Inc., Madison. pp. 643–698.
- King L.D. and Buchanan M. 1993. Reduced chemical input cropping systems in the Southeastern United States I: Effect of rotations, green manure and nitrogen fertilizer on yields. *Ame. J. Alternative Agric.* 8: 58–77.
- Ladd J.N. and Amato M. 1986. The fate of N from legume fertilizer sources in soils successively cropped with wheat under field conditions. *Soil Biol. Biochem.* 18: 417–425.
- Lekkerkerk L., Lundkrisk H., Alhgren G.I., Ekbohn G. and Bosatta E. 1990. Decomposition of heterogeneous substrates: an experimental investigation of a hypothesis on substrate and microbial properties. *Soil Biol. Biochem.* 22: 161–167.
- MacKown C.T., Brooks P.D. and Smith M.S. 1987. Diffusion of nitrogen-15 Kjeldahl digests for isotope analysis. *Soil Sci. Soc. Am. J.* 51: 87–90.
- Magdoff F. 1991. Managing nitrogen for sustainable maize systems: Problems and possibilities. *Am. J. Alt. Agric.* 6: 3–8.
- Maidi F.X., Suckert J., Funk R. and Fisdibeck G. 1991. Field studies on nitrogen dynamics after cultivation of grain legumes. *J. Agron. Crop Sci.* 167: 259–268.
- Muriuki A.K. 2000. Tracing ¹⁵N in cropped and uncropped soil treated with enriched potassium nitrate and labeled clover residues. Ph.D. Thesis. North Carolina State University.
- Muriuki A.W., King L.D. and Volk R.J. 2001. Nitrogen-15 recovery in soil incubated with potassium nitrate and clover residues. *Soil Sci. Soc. Am. J.* 65: 1430–1436.
- Newbould, P. 1989. The use of nitrogen fertilizer in agriculture. Where do we go from here practically and ecologically? *Plant Soil* 115: 297–311.
- Patra D.D., Bhandari S.C. and Misra A. 1992. Effect of plant residues on the size of microbial biomass and nitrogen mineralization in soil: incorporation of cowpea and wheat straw. *Soil Sci. Plant Nutri.* 38: 1–6.
- Ranells N.N. and Waggoner M.G. 1992. N release from crimson clover in relation to plant growth stage and composition. *Agron. J.* 84: 424–430.
- Reddy G.B. and Reddy K.R. 1993. Fate of N-15 enriched ammonium nitrate applied to maize. *Soil Sci. Soc. Am. J.* 57: 111–115.
- Sarrantonio M. and Scott T.W. 1988. Tillage effects on availability of nitrogen to maize following a winter green manure. *Soil Sci. Soc. Am. J.* 52: 1661–1668.
- SAS Institute Inc. 1989. *SAS/STAT @ Users guide, version 6, 4th edition, volume 2*. SAS.
- Shaviv A. and Mikkelsen R.L. 1993. Controlled-release fertilizers to increase efficiency of nutrient use and minimize environmental degradation –A review. *Fert. Res.* 35: 1–12.
- Thiagalingam K. and Kameliaro Y. 1973. Effect of temperature on N transformation in Hawaiian soils. *Plant Soil* 38: 177–189.
- Timmons D.R. and Cruse R.M. 1990. Effect of fertilization method and tillage on N-15 recovery by maize. *Agron. J.* 82: 777–784.
- USDA 1990. *Agricultural statistics*. United States government printing office. Washington D.C. pp. 571.
- Varco J.J., Frye W.W., Smith M.S. and MacKown C.T. 1989. Tillage effects on N recovery by maize from a N-15 labeled legume cover crop. *Soil Sci. Soc. Am. J.* 53: 822–827.
- Varvel G.E. and Peterson T.A. 1990. Nitrogen fertilizer recovery by maize in mono-culture and rotation systems. *Agron. J.* 82: 935–938.
- Volk R.J. and Jackson W.A. 1979. Preparing nitrogen gas for nitrogen-15 analysis. *Anal. Chem.* 51: 463–463.
- Volk R.J., Pearson C.J. and Jackson W.A. 1979. Reduction of plant tissue nitrate to nitrite oxide (NO) for mass spectrometric ¹⁵N analysis. *Anal. Biochem.* 97: 131–135.
- Watkins N. and Barraclough, D. 1996. Gross rates of N mineralization associated with the rates of decomposition of plant residues. *Soil Biol. Biochem.* 28: 169–175.
- Wilson D.O. and Hargrove W.L. 1986. Release of nitrogen from crimson clover residues under two tillage systems. *Soil Sci. Soc. Am. J.* 50: 1251–1254.

Evaluation of nitrogen fixation using ^{15}N dilution methods and economy of a maize-tepary bean intercrop farming system in semi-arid SE-Kenya

Chris A. Shisanya¹ and Nkanata M. Gitonga²

¹*Kenyatta University, Department of Geography, P.O. Box 43844 GPO 00100 Nairobi, Kenya, Tel: +254-20-810901Ext. 57321; Fax: +254-20-811575; E-mail: shisanya@yahoo.com (Corresponding author);* ²*Kenyatta University, Department of Biological Sciences, E-mail: gitonga35@avu.org*

Abstract

Tepary bean has become popular among poor small-scale farmers in semi-arid Kenya, where it is intercropped with maize. This study aimed at i) evaluating the N-economy of maize/tepary bean intercrop versus sole crop using natural abundance and ^{15}N enriched fertilizer methods, and ii) assessing the contribution of fixed N_2 by tepary bean to the total N balance in the intercrops and sole cropping systems assessed from harvested seed and residues. Experiments were carried out during the short rains of 2001/2002 and long rains of 2003 at Kenya Agriculture Research Institute (KARI) Kiboko, Kenya. Randomised block design was used with one block devoted to the ^{15}N natural abundance ($-\text{N}$), the other ^{15}N labelled fertilizer ($+\text{N}$), replicated 4 times. Above ground biomass and total N were determined in sole crops or intercrops ($-\text{N}$ or $+\text{N}$). Tepary bean received 53–69% of its N supply from N_2 -fixation with N_2 -fixation slightly affected by intercropping or N fertilizer application. N_2 -fixation of tepary in greenhouse experiment was lower (36–66%) than in the field study and more affected by N supply. Budgets for N were estimated for field intercrops based on above-ground seed yields, return of crop residues, input of fixed N and fertilizer N. N_2 -fixation was 59 kg N ha⁻¹ in plots receiving no N fertilizer, and 73 kg N ha⁻¹ in plots receiving N as urea. Corresponding fixation by sole tepary was high (87 and 82 kg N ha⁻¹, respectively), but this advantage was outweighed by greater land use efficiency in intercrop than sole crop

Key words: ^{15}N dilution methods; Kenya; intercropping; maize; Tepary bean

Introduction

The Government of Kenya has underscored the important role played by the arid and semi-arid lands (ASALs) of Kenya in food production (Republic of Kenya, 1993). Currently, food production has been declining in these ASALs as population growth increases (Rao and Mathuva, 2000; Maingi et al., 2001; Shisanya, 2002), and also because long periods of fallow are no longer practiced and the land is cropped continuously after clearing. Fertilizer use is low because of socio-economic constraints, its unavailability at the right time, its high cost, and risks from erratic rainfall. As a result, yields of cereals do not exceed 1 t ha⁻¹,

and legumes 0.5 t ha⁻¹ per crop season (Tiffen et al., 1994). It is therefore a major challenge to sustain crop yields and economic returns in such low input agricultural systems, predominantly by small-scale farm.

Various researchers have emphasized the importance of research on drought tolerant crop species of short cycle as a priority in addressing the food deficit problem in the ASALs (Hornetz et al., 2000; Shisanya, 2002, 2004). Unfortunately, this has not received adequate attention (Shisanya, 1999). Most smallholder farmers in the ASALs cannot afford the required external inputs in the form of chemical N fertilizer to improve their food production. Researchers in Kenya have exploited

the legume *Rhizobium* symbiosis as a substitute for the expensive N fertilizers in these ASALs (Gitonga et al., 1999; Hornetz et al., 2000; Maingi et al., 2001; Shisanya, 2002, 2004). Nitrogen (N) contribution by legumes to other crops in the system depends on the species, biological N_2 fixation and growth of legumes as determined by climate and soil, and management of residues.

In semi-arid Kenya, maize (*Zea mays* L.) is commonly intercropped or rotated with bean (*Phaseolus vulgaris* L.), pigeon pea (*Cajanus cajan* L. Millsp.) or cowpea (*Vigna unguiculata* L. Walp), although the relative proportion of the legume in these mixed systems is small. Tepary bean (*Phaseolus acutifolius* A. Gray var. latifolius), a drought tolerant legume (Hornetz, 1990) has recently assumed importance in the intercrop farming systems of semi-arid Kenya (Shisanya, 2002). The N removed by maize in this region is estimated to be as much as 25–40 kg ha⁻¹ per season, which means that a matching amount of N needs to be supplied for long term sustainability of production (Rao and Mathuva, 2000). Nitrogen fixation by bean is notoriously inconsistent, with or without inoculation (Maingi et al., 2001), but cowpea nodulates well by the ubiquitous *Bradyrhizobia* sp. and fixes up to 20 kg N ha⁻¹ (Pilbeam et al., 1995). Recently, Shisanya (2004) found that tepary bean (TB) nodulates very well with *Rhizobium* sp. strain R3254 and fixes up to 260 kg N ha⁻¹. However, this study by Shisanya (2004) did not investigate the effect of intercropping maize and TB on nitrogen fixation and the actual amount fixed by the latter under the semi-arid conditions. Further, the study did not make an assessment of the contribution of fixed N_2 by tepary bean to the total balance of the intercrop farming system. Earlier studies (Gitonga et al., 1999; Maingi et al., 2001) investigated the effect of intercropping on nitrogen fixation by common bean and green gram (*Vigna radiata* L. Wilczek) under semi-arid conditions.

In view of the above, the main objectives of this study were, therefore to: (1) evaluate the relative efficiency of maize/teparty bean intercrop versus sole cropping situation under the semi-arid conditions of southeast Kenya, (2) evaluate the N-economy of maize/teparty bean intercrop versus sole crop using the natural abundance and ^{15}N enriched and (3) assess the contribution of fixed N_2 by tepary bean to the total balance of N in the intercrops and sole cropping farming systems as assessed in terms of harvested seed and crop residues, under the semi-arid conditions of southeast Kenya.

Materials and methods

Experimental site

The experiments were carried out at Kenya Agriculture Research Institute (KARI) Kiboko sub-centre (latitude 02° 12' S, longitude 37° 43' E, altitude 975 m a.s.l.), located at about 160 km southeast of Nairobi, the capital town of Kenya. The climates of the experimental site is described as hot and dry (Hornetz et al., 2000). The soils are well drained Fluvisols, Ferralsols and Luvisols (Eichinger, 1999). Rainfall is bimodally distributed, with median monthly maximum in April (126 mm) and November (138 mm). The medial annual rainfall is about 582 mm year⁻¹. The short rains (SR) (October–January) generally have more rainfall and are more reliable than the long rains (LR) (March–June) (Hornetz et al., 2000). The lengths of the agrohumid periods for drought-adapted crops are 50–55 days (LR) and 65–70 days (SR) (Jaetzold and Schmidt, 1983). Average monthly temperatures are highest in February (24.3°C) and October (23.4°C) (Shisanya, 1996) prior to the onset of the rains in March and November, respectively. Preliminary soil analysis indicated that the N and P in 0–60 cm soil depth were 0.7 mg N kg⁻¹ and 3.0 mg P kg⁻¹ soil respectively. The C/N ratio and CEC are 11.7 and 7.8 ML⁻¹, respectively. The soil pH of the experimental field was acid (5.3) (measured in 0.01 ML⁻¹ CaCl₂).

Field experiments

Field experiments were conducted over two seasons, i.e. short rains (SR) 2001/2002 (October–January) and long rains (LR) 2002 (March–June). A basal dose of triple superphosphate (TSP) fertilizer was applied at the rate of 40 kg ha⁻¹ on all the plots to alleviate phosphorus deficiency. The N treatment plots (+N) received calcium ammonium nitrate fertilizer (CAN) (26% N) at the same rate as TSP. The experimental layout comprised two randomised block designs (Figure 1). One block was devoted to the ^{15}N -natural-abundance (-N) study, the other to the ^{15}N -labelled fertilizer (+N) experiment. The (-N) and (+N) blocks each consisted of four replicate plots of sole maize (M), sole tepary bean (TB), or intercropped maize/teparty bean (MTB) (Figure 1). The plots were sown on 3rd November and 4th April for the short rains and long rains experiments, respectively. In the (+N) study, all treatments were given a basal dose of 40 kg ha⁻¹

of N as urea, except for the unconfined microplots (3 m × 0.75 m), which were carefully watered (to avoid contamination) with ¹⁵N-urea solution (1.37% atom excess ¹⁵N) after post emergence thinning, at an equivalent rate of 40 kg N ha⁻¹. Unlabelled urea was added to the remainder of the block at the same rate. Each experimental plot measured 8 m × 6 m and consisted of 6 raised seedbeds separated by an irrigation furrow. The sole crops M, TB and TB comprised a two-row layout on each seedbed, with rows 75 cm apart with a spacing of 30 cm between plants

in the row for (M), yielding a plant density of 44,000 plants/ha. The TB and SB spacing were 50 cm between rows and 20 cm within rows, giving a density of 100,000 plants/ha. The intercrop plots consisted of central plots of maize with flanking rows of TB. The above planting densities are those recommended for semi-arid southeast Kenya (Hornetz et al., 2000; Shisanya, 1998). TB was inoculated with a peat culture in gum *arabic* incorporating the effective Rhizobium strain R3254 according to the method described by Kibunja (1984).

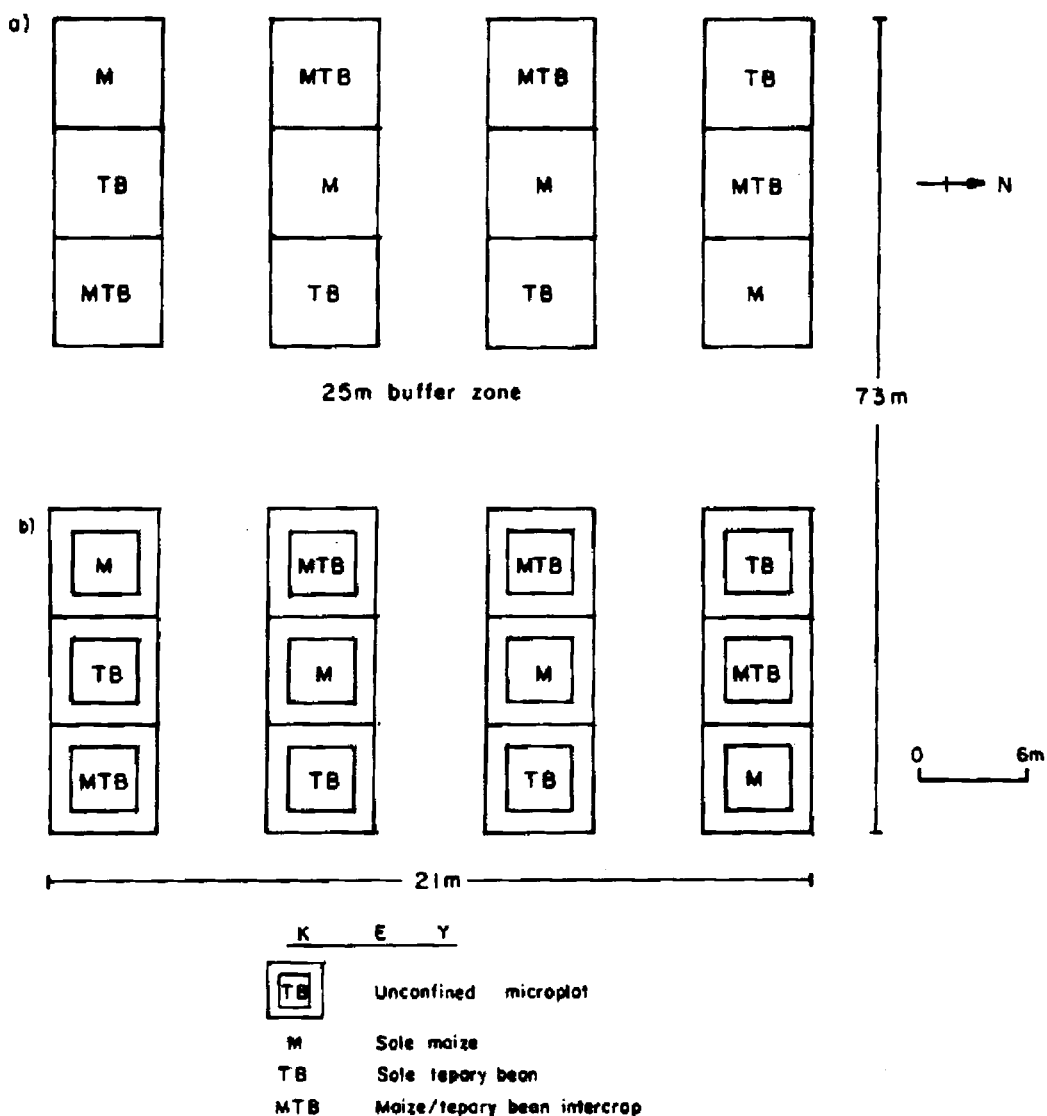

Figure 1. Plan of field site, (a) No added fertilizer N (-N experiment) (b) Fertilizer added (40 kg ha⁻¹) (+N experiment).

Maize, tepary seeds, and *Rhizobium* culture

Seeds of maize (cv. Makueni DLC1) and tepary bean (cv. latifolius) were obtained from local farmers. Undamaged seeds were carefully selected to ensure uniformity in size. Commercial *Rhizobium leguminosarum* biov. *phaseoli* strain R3254 used to inoculate TB was obtained from the Microbiological Resource Centre (MIRCEN), University of Nairobi. The infectivity and effectivity of this strain had been established in an earlier study (Shisanya, 2002).

Harvests from field plots

A 90-day harvest of 10 plants was made from the middle region of each unconfined, ^{15}N -fertilized treated microplot of assay of ^{15}N , in order to determine the extent of dependence of the crop species on the applied fertilizer N.

Greenhouse experiment

This was conducted in a naturally-lit greenhouse in the Department of Botany, Kenyatta University. Air temperatures ranged from 23 to 28°C, using evaporative cooling and shadecloth (75% transmission) to prevent excessively high temperatures on sunny days. The soil used in the experiment was collected from a fallow area at the field experimental site, sieved to pass through a 2-mm mesh, and supplemented with superphosphate and KCl at rates equivalent to that of the field study. The experiment involved four replicates, i.e. 24 pots sown to maize and tepary bean or maize plus tepary bean, with or without ^{15}N -labelled urea. Post emergence densities were 1 maize, 2 tepary beans, or 1 maize plus 2 tepary bean plants per pot. Yields of total above-ground biomass and seed, and ^{15}N analyses of total N were made for the (-N) and (+N) treatments at plant maturity (90 days). An additional series of greenhouse grown plants of tepary beans inoculated with *Rhizobium* R3254 was raised in minus nitrogen sand culture. Plants were harvested at 30, 60 and 90 days and total N of shoot, nodule and root dry matter analysed for ^{15}N natural abundance. Estimates were thus obtained of the isotopic fractionation (so called B value) realized by nodulated tepary bean subsisting on atmospheric N_2 (Amarger et al., 1979).

^{15}N analysis of soil and plant dry matter

Samples of soil or plant dry matter were prepared and analysed according to the methods described by (Boddey et al., 2000; Bergersen, 1980). ^{15}N analyses were done at the UFZ Centre for Environmental Research in Leipzig-Halle, Germany, using a triple ion collector, dual inlet mass spectrometer (SIRA 9, VG Isogas, Middlewich, Cheshire, UK), incorporating a direct inlet line from hypobromite oxidation system similar to that described by Porter and O'Deen (1977). The standard reference source for ^{15}N analysis was a sample of $(\text{NH}_4)\text{SO}_4$ showing 0.36598 ± 0.00001 atom% ^{15}N and a $\delta^{15}\text{N}$ of $-0.87 \pm 0.024\%$. All $\delta^{15}\text{N}$ values for the (-N) materials were calculated in the conventional manner i.e.:

$$\delta^{15}\text{N} (5) = 1000 \times (\text{R}_{\text{sample}} - \text{R}_{\text{reference}}) / \text{R}_{\text{reference}} \quad (1)$$

where: $\text{R} = {}^{15}\text{N}^{14}\text{N} / {}^{14}\text{N}^{14}\text{N}$ (mass 29/mass 28)

Estimation of N_2 fixation by tepary bean

The percentage of N_2 fixed by tepary bean from the atmosphere was estimated by ^{15}N natural abundance at each harvest, and at the final harvest only in the ^{15}N -enriched fertilizer experiment.

- a) ^{15}N natural abundance: Percent N fixed was calculated using the expressions of Bergersen and Turner (1983):

$$\% \text{N fixed} = \left((\delta^{15}\text{N}_{\text{maize}} - \delta^{15}\text{N}_{\text{tepar y bean}}) / (\delta^{15}\text{N}_{\text{maize}} - \delta \text{B}) \right) \times 100 \quad (2)$$

where: B is the δ value of the N of total plant dry matter of tepary beans grown in N-free sand medium in the greenhouse.

- b) ^{15}N -enriched fertilizer: Percent N fixed was calculated as follows:

$$\% \text{Ndfa} = \left[1 - \text{E}_{\text{fixing plant}} / \text{E}_{\text{reference plant}} \right] \times 100 \quad (3)$$

$$\text{Ndfa (kg/ha)} = \% \text{Ndfa} \times \text{Total N in fixing crop (kg/ha)} / 100 \quad (4)$$

where: %Ndfa = Percent N derived from the atmosphere, and

E = atom% excess of either N₂-fixing plant or the reference plant

Soil analysis

Soil samples were collected to a depth of 60 cm using a soil auger before planting. Five sub-samples were collected from each plot, mixed thoroughly in polythene bags and transported to the laboratory. Soil organic C was analysed according to the method described by Anderson and Ingram (1993), total N according to (Forster, 1995a; Bremner and Mulvaney, 1982) and soil P (Forster, 1995b).

Statistical analysis

The data were subjected to analysis of variance and pairwise multiple comparisons were based on least

significance difference (LSD) among treatment means (Steel and Torrie, 1981).

Results

Dry matter yields, N and land equivalent ratio for field experiments

Dry matter gains by sole crops and intercrops of maize in the presence or absence of fertilizer N were as plotted in Figures 2a and 2b. Analysis of variance for data at final harvest showed significant ($p < 0.05$) reductions in yield of either species with intercropping in both the N fertilized (+N) or unfertilised (-N) plots. Both crop species, sole or intercropped, responded positively to N fertilizer application, but to a greater degree in maize than in tepary bean. Overall, yielding capacities between the two seasons bore evidence of yield responses to N by both crops whether as sole crops or intercrops, and remarkably similar values between the two seasons for LER. Intercropping advantages,

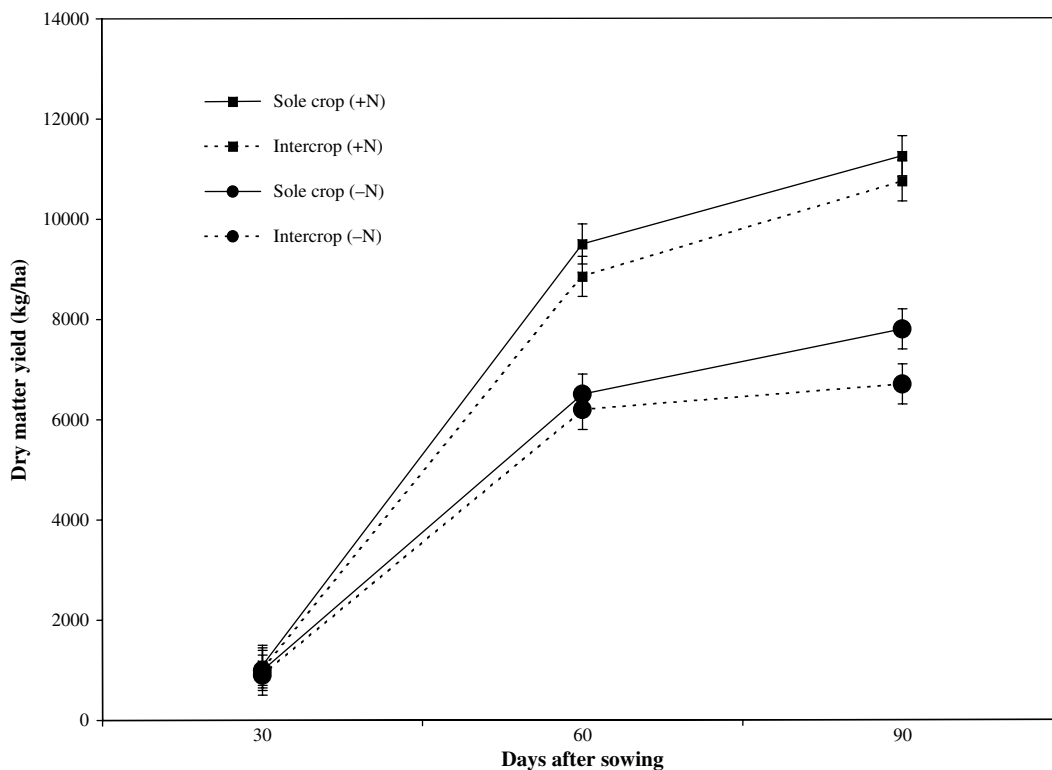

Figure 2a. Dry matter yields of maize as influenced by intercropping and N fertilizer under field conditions. Vertical bars indicate LSD ($p < 0.05$) to compare sole crops and intercrops, with or without added N fertilizer at 90 days harvest.

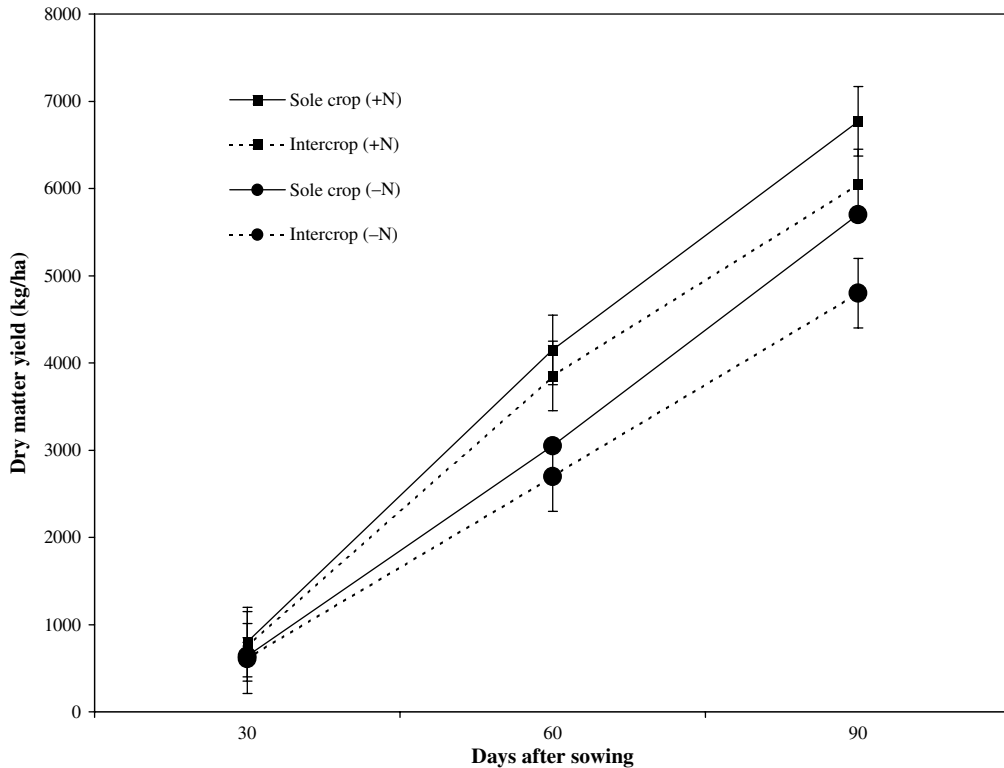

Figure 2b. Dry matter yields of tepary bean as influenced by intercropping and N fertilizer under field conditions. Vertical bars indicate LSD ($p < 0.05$) to compare sole crops and intercrops, with or without added N fertilizer at 90 days harvest.

in terms of LER, ranged between 59 and 102% for dry matter and 85 to 98% for grain yield for crops grown without N fertilizer compared with 82–88% and 82–90%, respectively for N fertilized treatments (Table 1).

Nitrogen yields for the field experiments showed similar trends to those for dry matter, with no significant increase of %N in dry matter at final harvest due to N-fertilizer application (Table 2). Nitrogen yield and N concentrations in seed and straw were significantly higher with N fertilizer application, except for tepary bean in association with maize, where growth was suppressed. Significant differences ($P < 0.05$) were evident between sole crops and intercrops in respect of N yields of tepary bean and maize in the greenhouse experiments. The nodulated tepary bean plants grown separately in nitrogen free sand medium gave $\delta^{15}\text{N}$ values for shoot biomass within the range +0.26 to +0.38% (atom % ^{15}N 0.36638 to 0.36642) i.e. close to the atmospheric N_2 ($\delta^{15}\text{N} = 0$). ^{15}N values for the above ground biomass of the ^{15}N -enriched fertilizer plots showed proportionality greater dilution of ^{15}N in tepary bean than in maize (Table 3).

Estimating the proportion of dependence of tepary bean on symbiotic N_2 -fixation and yields of fixed N

The proportion (%) of plant final N of sole crop and intercrop tepary bean arising from atmospheric N_2 are given in Table 4. The data for (-N) experiment suggest that approximately two thirds of the nitrogen of tepary bean resulted from N_2 -fixation, with no evidence of statistically significant difference in %N-fixed values between sole crop and intercrop. The comparable (-N) greenhouse plants showed lower %N-fixed values (42–50%) for sole crop than in the field experiments, probably indicative of higher rates of availability of mineralised N in pot culture. These greenhouse intercrops, however, gave %N-fixed values (63–72%) equalling those of the field study and significantly greater than sole tepary bean under greenhouse conditions.

Percent-N-fixed values for the (+N) experiments in the greenhouse study, showed lower dependence on fixed N_2 than in (-N) experiment. This was to be expected from the well-known inhibitory effect of combined N on symbiotic activity. However, comparison

Table 1. Yields of total dry matter (TDM), grain and land equivalent ratios (LER) of maize and tepary beans planted with or without nitrogen (N) fertilizer in the field

Cropping system		SR 2001/2002			LR 2002		
		Yield (kg ha ⁻¹)					
		TDM	Grain	LER	TDM	Grain	LER
Sole crop							
Maize	(-N)	8400	2800		7200	2500	
	(+N)	12200	4280		10300	4150	
Tepary bean	(-N)	6300	950		5100	1000	
	(+N)	7100	1280		6500	1320	
				TDM	Grain		TDM
Intercrop							
Maize	(-N)	6800	2650	0.81 ^a	0.95 ^a		1.08 ^a
	(+N)	11300	3960	0.93	0.93		0.99
Tepary bean	(-N)	5000	980	0.79 ^a	1.03 ^a		0.94 ^a
	(+N)	6300	1200	0.89	0.94		0.89
Total	(-N)	11800	3630	1.59	1.98		2.02
	(+N)	17600	5160	1.82	1.87		1.88

^a Partial LER for single species of intercrop.

between percent-N-fixed values of field-grown (+N) and (-N) tepary beans showed reduced dependence on N₂-fixation only where sole tepary beans had received N fertilizer. Yields of fixed N (Table 4) were suppressed appreciably by intercropping in the (-N) plots, but not in comparably treated greenhouse experiment. The reverse obtained for the (+N) treatments in which greenhouse grown plants, but not field grown plants, showed markedly reduced yields of fixed N through competition.

Discussion

Tepary bean plants had lower ¹⁵N atom % excess, though not significant, than maize (Table 3). The application of P-fertilizer has been found to significantly affect the ¹⁵N dilution effects, especially during plant reproductive stage (Irungu et al., 2002). The BNF symbiosis is a culmination of interactions between the host plant, rhizobia and environment (Boddey et al., 2000). Consequently, tackling the limitations, which hinder the optimal functioning of the BNF symbiosis, can only enhance BNF. The limitations include lack of suitable rhizobia, poor N₂-fixing legumes, and environmental limitations (Irungu et al., 2002).

Lack of suitable rhizobia can be tackled through production and inoculation with efficient host-specific rhizobia or in the absence of an elaborate breeding

programme, selection of a suitable legume that nodulates abundantly and forms effective symbiosis with indigenous rhizobia. In the study area, tepary bean nodulated very well with indigenous *Rhizobium leguminosarium* sp. (Shisanya, 2002). However, as reported by Giller and Wilson (1991), acute deficiency of P can prevent nodulation and hence N₂ fixation by legume. It is for this reason that all treatment plots received a basal dose of P at the rate of 40 kg P ha⁻¹ before planting.

This study has provided further evidence in addition to a previous one (Shisanya, 2002) that there exists a substantial symbiotic activity of tepary beans, whether grown as sole or intercropped with maize. From the ¹⁵N-natural abundance (-N) or ¹⁵N-enriched fertilizer (+N) studies, the data showed lower percentage reliance of tepary beans on symbiotic N₂-fixation in (+N) treatments in which fertilizer N was applied than in unfertilised (-N) treatments. N fertilizer applications have been found to suppress N uptake and N₂ fixation in legumes (Kerley and Jarvis, 1999). For example a lack of response by cowpea (*Vigna unguiculata* L. Walp) to N application in the study has been reported by Pilbeam et al., 1995. A limiting factor in the drylands of southeast Kenya is that the prevalent soils, i.e. Fluvisols, Luvisols and Ferralsols (Eichinger, 1999), release important available plant nutrients only after a very short period of cultivation and through leaching (Eichinger, 1999; Hornetz, 1997). In addition, N-uptake by crops may be constrained by low root

Table 2. Nitrogen yields and nitrogen concentrations in dry matter of maize and tepary beans as influenced by intercropping under field and greenhouse conditions

Harvest	Cropping System	Maize		Tepary bean	
		N yield matter	%N in dry matter	N yield	%N in dry Matter
<i>(-N) study.</i>					
<i>Field study</i>					
		<i>kg ha⁻¹</i>		<i>kg ha⁻¹</i>	
30 days	Sole crop	17.5	0.55	29.9	1.62
(shoot)	Intercrop	15.3	0.52	15.6	1.49
60 days	Sole crop	32.8	1.01	49.9	2.68
(Shoot)	Intercrop	38.5	0.95	25.6	2.40
90 days	Sole crop	68.0	0.90	90.6 ^a	1.95
(Shoot)	Intercrop	61.3	0.88	73.5	1.65
90 days	Sole crop	20.4	0.25	45.0	0.72
(Straw)	Intercrop	19.5	0.27	29.3	0.70
90 days	Sole crop	57.4	1.20	80.4 ^a	4.50
(Seed)	Intercrop	46.4	1.10	60.2	4.30
90 days	Sole crop	77.8	0.72	125.4 ^a	1.52
(Seed+Straw)	Intercrop	65.9	0.70	89.5	1.63
<i>Greenhouse study</i>					
		<i>mg N pot⁻¹</i>		<i>mg N pot⁻¹</i>	
90 days	Sole crop	520 ^a	0.66	750 ^a	0.94
(Straw)	Intercrop	330	0.56	500	0.98
90 days	Sole crop	1020 ^a	1.20	1390 ^a	4.30
(Seed)	Intercrop	700	1.18	860	4.20
90 days	Sole crop	1600 ^a	0.82	2040 ^a	1.86
(Seed+Straw)	Intercrop	1040	0.80	1370	1.89
<i>(+N) experiment (40 kg ha⁻¹)</i>					
<i>Field study</i>					
		<i>kg ha⁻¹</i>		<i>kg ha⁻¹</i>	
90 days	Sole crop	31.5 ^a	0.46	55.0 ^a	1.06
(Straw)	Intercrop	27.8	0.41	39.9	1.05
90 days	Sole crop	73.1 ^a	1.15	97.5	3.80
(Seed)	Intercrop	59.8	1.09	68.0	3.75
90 days	Sole crop	104.6 ^a	0.80	152.5 ^a	1.98
(Seed+Straw)	Intercrop	87.6	0.78	107.9	1.96
<i>Greenhouse study</i>					
		<i>mg N pot⁻¹</i>		<i>mg N pot⁻¹</i>	
90 days	Sole crop	705	0.60	785	1.05
(Straw)	Intercrop	680	0.66	460	1.00
90 days	Sole crop	1450 ^a	1.40	1740 ^a	3.90 ^a
(Seed)	Intercrop	996	1.30	770	3.68
90 days	Sole crop	2100 ^a	0.98	2510 ^a	2.20
(Seed+Straw)	Intercrop	1620	0.96	1220	1.98

^aDifferences between sole crop and intercrop significant at $p < 0.05$.

density, which is typical of tepary bean and cowpea (Shisanya, 1998), and or inadequate soil moisture content by which mineral N can move to the plant root (Pillbeam et al., 1995). However, results from this study in +N treatments were contrary to the above observations as will be shown later on in the discussion.

One of the objectives of this study was to evaluate the economy of nitrogen in a maize/tepar bean intercrop. In the absence of fertilizer (-N experiment), the amounts of fixed N in above-ground biomass of

tepar bean (59 kg N ha⁻¹), almost balanced with the amount of N removed as tepary bean seed (60 kg N ha⁻¹) (Table 2). The amount of N removed as maize seed was 46 kg N ha⁻¹. Thus, essentially, there was a deficit of 46 kg N ha⁻¹ in the system (Figure 3a). In the presence of N fertilizer (+N experiments), the amounts of N in the above-ground biomass of tepary bean was 73 kg N ha⁻¹, while N removed as tepary seed was 68 kg N ha⁻¹ (Table 2 and Figure 3b). The amount of N removed as maize seed was 60 kg N ha⁻¹. In this +N

Table 3. ^{15}N abundance values of maize and tepary beans as sole crops or intercrops under field and greenhouse conditions with and without ^{15}N -enriched fertilizer

Harvest	Cropping	Maize	Tepary bean
<i>(-N) study.</i>			
Field study			
60 days	Sole crop	$\delta^{15}\text{N} \%$ 6.7 (0.73) ^a	$\delta^{15}\text{N} \%$ 6.3 (0.47)
(Shoot)	Intercrop	7.6 (1.07)	5.9 (0.41)
90 days	Sole crop	6.5 (0.97)	4.3 (0.90)
(Shoot)	Intercrop	6.2 (0.64)	3.1 (0.12)
90 days	Sole crop	6.8 (0.72)	2.1 (0.07)
(Straw)	Intercrop	5.0 (0.48)	2.1 (0.22)
90 days	Sole crop	7.0 (0.81)	2.4 (0.30)
(Seed)	Intercrop	6.6 (0.90)	2.3 (0.12)
<i>Greenhouse study</i>			
90 days	Sole crop	$\delta^{15}\text{N} \%$ 2.4 (0.21)	$\delta^{15}\text{N} \%$ 1.5 (0.21)
(Straw)	Intercrop	3.6 (0.42)	1.2 (0.19)
90 days	Sole crop	4.1 (0.48)	2.2 (0.34)
(Seed)	Intercrop	3.9 (0.29)	1.6 (0.10)
<i>(+N) experiment (40 kg ha⁻¹)</i>			
Field study			
90 days	Sole crop	<i>Atom % ¹⁵N</i> 0.4151 (0.0061)	<i>Atom % ¹⁵N</i> 0.3919 (0.0049)
(Straw)	Intercrop	0.4233 (0.0031)	0.3864 (0.0059)
90 days	Sole crop	0.4149 (0.0064)	0.3872 (0.0037)
(Seed)	Intercrop	0.4150 (0.0050)	0.3813 (0.0037)
<i>Greenhouse study</i>			
90 days	Sole crop	<i>Atom % ¹⁵N</i> 0.5554 (0.0216)	<i>Atom % ¹⁵N</i> 0.5069 (0.0081)
(Straw)	Intercrop	0.5389 (0.0179)	0.5047 (0.0119)
90 days	Sole crop	0.5227 (0.0168)	0.4586 (0.0087)
(Seed)	Intercrop	0.5384 (0.0160)	0.4591 (0.0084)

^aValues in parentheses are standard errors of 2 replicate analyses 5 or 10 plant samples from each plot (see text for details).

experiment, there was a net loss to the soil of 21 kg N ha⁻¹. This comprised a relatively small deficit in comparison to that shown by the (-N) plots. Amounts of N in the total biomass, harvested seed and crop residues of maize and tepary bean components were higher in the fertilized than unfertilised, and somewhat surprisingly, N-fertilizer application appeared to have promoted a greater return of fixed N in tepary bean shoots (73 kg N ha⁻¹) than in the unfertilised situation (42 kg N ha⁻¹). This may have been due to the greater competitiveness of maize than cowpea in acquiring the added fertilizer (Maingi et al., 2001).

Nitrogen derived from fertilizer by intercrop maize was 5.3 kg N ha⁻¹ and fertilizer use efficiency 22%. In intercrop tepary bean, these values were 3.6 kg N ha⁻¹ and 15%, respectively. Maize thus met 5.3% of its N requirement from the ^{15}N -labelled fertilizer compared with 1.7% for tepary bean. Overall, intercrop above ground biomass derived 59.5% of its N from the soil, 3.3% from the added fertilizer and 37.3%

from atmospheric N₂ fixation, suggesting that proportional benefits from symbiotic fixation were not significantly depressed by N fertilizer application, as pointed out earlier in this discussion. However, a detailed cost benefit analysis would be required to determine whether N fertilizer application is warranted under conditions in semi-arid southeast Kenya, and, if so, how its effectiveness might be reduced were extensive leaching of applied fertilizer to occur during the crop cycle.

A major inadequacy of the present approach, and other similar studies (Amarger et al., 1979; Kohl et al., 1980; Bergersen et al., 1990; Hardarson et al., 1991), is that no measurements were made of N in root biomass, especially in relation to the amount of fixed N added by legume component through decay of roots and nodules at the end of the growing season. It is proposed that such an approach be considered in future in similar studies. The present data using the ^{15}N -natural-abundance technique were encouraging in

Table 4. Proportional dependence on N_2 -fixation and N_2 fixed by sole and intercrop estimated by ^{15}N -labelled fertilizer method under field and greenhouse conditions

Harvest	Cropping	% N fixed	N_2 fixed ^a
<i>(-N) study.</i>			
<i>Field study</i>			<i>kg N ha⁻¹</i>
90 days	Sole crop	73.1	32.9
(Straw)	Intercrop	62.5	18.3
90 days	Sole crop	69.3	55.7
(Seed)	Intercrop	68.9	41.5
90 days	Sole crop	70.0	87.8
(Straw + Seed)	Intercrop	63.5	42.4
<i>Greenhouse study</i>			<i>mg N pot⁻¹</i>
90 days	Sole crop	44.3b	330
(Straw)	Intercrop	74.2	370
90 days	Sole crop	50.9	657
(Seed)	Intercrop	62.7	537
90 days	Sole crop	46.5	947
(Straw + Seed)	Intercrop	66.1	896
<i>(+N) experiment</i> <i>(40 kg ha⁻¹)</i>			
<i>Field study</i>			<i>kg N ha⁻¹</i>
90 days	Sole crop	47.6	26.2
(Straw)	Intercrop	64.9	25.9
90 days	Sole crop	57.1	55.7
(Seed)	Intercrop	69.3	47.1
90 days	Sole crop	53.4	81.9
(Straw + Seed)	Intercrop	67.7	73.0
<i>Greenhouse study</i>			<i>mg N pot⁻¹</i>
90 days	Sole crop	25.7	200 ^b
(Straw)	Intercrop	19.8	90
90 days	Sole crop	41.0	706 ^b
(Seed)	Intercrop	46.1	351
90 days	Sole crop	36.2	906 ^b
(Straw + Seed)	Intercrop	36.2	440

^aComputed by multiplying % N fixed by tepary bean N yield data (Table 2); ^bDifference between sole crop and intercrop significant at $P < 0.05$.

showing reproducible differences between legume and reference crop under field conditions, and sufficiently great differences between $\delta^{15}\text{N}$ values of tepary bean relying solely on atmospheric N_2 (B-values, Table 3) and $\delta^{15}\text{N}$ of soil and maize to suggest that the technique might be used in future occasions for monitoring N balance of legume/cereal intercrops. The values for percentage N_2 fixed by tepary beans using ^{15}N -natural abundance and ^{15}N -enriched fertilizer methods lay within the range 53–69%. Combining high symbiotic competence of tepary bean with considerable yield advantages of mixed culture with maize in comparison with growing either species separately, there would appear to be considerable potential advantages in practicing maize/tepar bean intercrop, especially where it is not feasible or economical to effect large

inputs of fertilizer to the cropping system as is the case in semi-arid southeast Kenya.

Acknowledgements

The International Foundation for Science (IFS), Stockholm, Sweden, supported this research work under grant number C/2832-2. The author is grateful for their generous financial assistance. The project field assistants Mr. Juma and Mr. Nobert are sincerely thanked for their input. The Director of KARI, Katumani Centre is thanked for giving permission for the use of the facilities at the centre under the management of Mr. Duncan Mutinda.

a) No added fertilizer N (-N)(experiment)

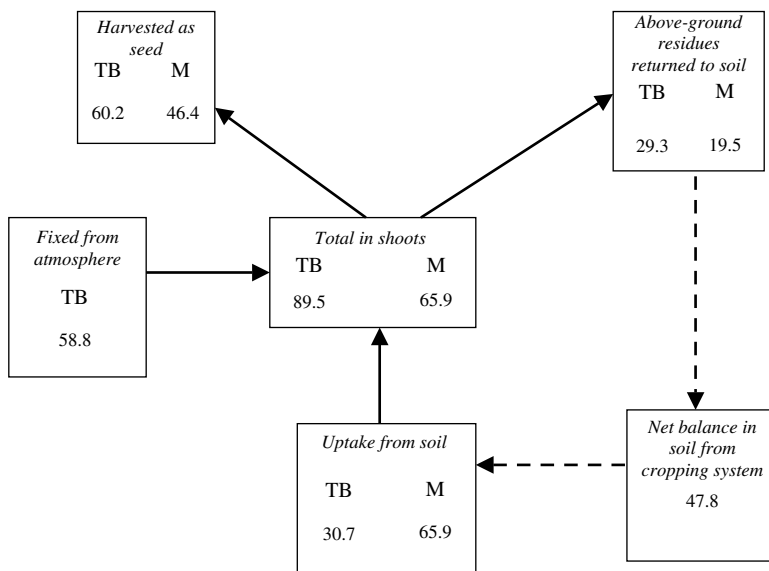

Figure 3a. Nitrogen budgets for maize tepary bean intercrops determined by ¹⁵N dilution methods without N fertilizer.

b) Fertilizer N added (40 kg N ha⁻¹)(+N) experiment)

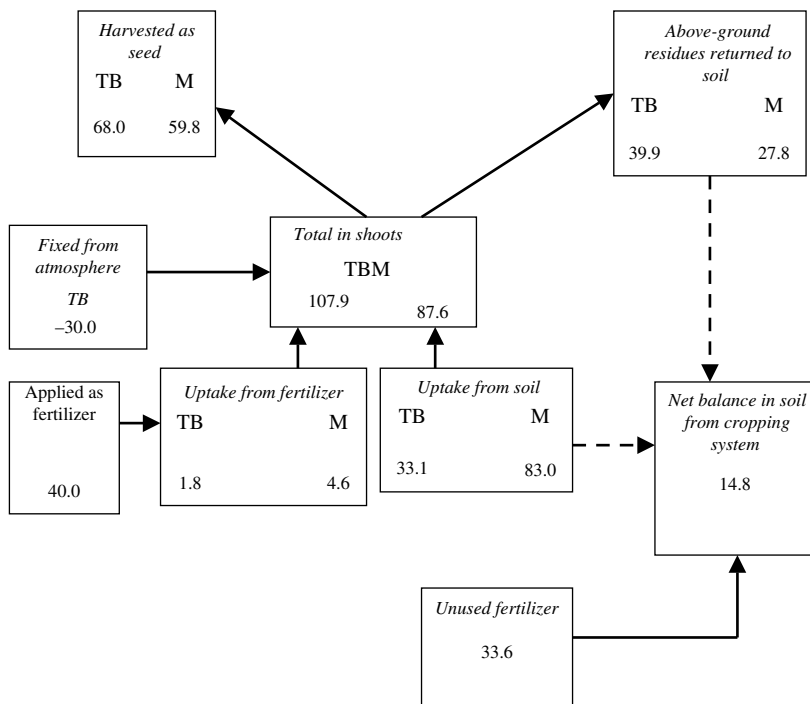

Figure 3b. Nitrogen budgets for maize tepary bean intercrops determined by ¹⁵N dilution methods with added N fertilizer (40 kg N ha⁻¹urea).

References

- Amarger N., Mariotti A., Mariotti F., Durr J.C., Bourguignon, C. and Lagacherie B. 1979. Estimate of symbiotically fixed nitrogen in field grown soybeans using variations in ^{15}N natural abundance. *Plant and Soil* 52: 269–280.
- Anderson, J.M., Ingram, J.S.I., 1993. *Tropical Soil Biological and Fertility: A Handbook of Methods* 2nd Ed. CAB International, Wallingford, U.K. 232pp.
- Bergersen F.J. and Turner G.L. 1983. An evaluation of ^{15}N methods for estimating nitrogen fixation in a subterranean clover-perennial ryegrass sward. *Austr. J. Agric. Res.* 34: 391–401.
- Bergersen F.J. 1980. Analysis of nitrogen fixation by direct means. In: Bergersen F.J. (Ed.) *Methods for Evaluating Biological Nitrogen Fixation*. John Wiley and Sons, Chichester, U.K., pp. 65–110.
- Bergersen F.J., Peoples M.B., Herridge D.F. and Turner G.L. 1990. Measurement of N_2 fixation by ^{15}N natural abundance in the management of legume crops: roles and precautions. In: Gresshoff P.M. (Ed.) *Nitrogen Fixation: achievements and objectives*. Chapman and Hall, New York, pp. 315–322.
- Boddey R.M., Peoples M.B., Palmer P. and Dart P.J. 2000. Use of the ^{15}N natural abundance technique to quantify biological nitrogen fixation by woody perennials. *Nutr. Cycl. Agroecosyst.* 152: 25–52.
- Bremner J.M. and Mulvaney C.S. 1982. Nitrogen-total. In: Page A.L., Miller R.H. and Keeney D.R. (Eds.) *Methods of Soil Analysis, Part 2. Chemical and Biological Properties*. Am. Soc. Agron. 9: 595–624.
- Eichinger M. 1999. Die Applikation von Gesteinmehlen als Alternative Düngemittel in den Trockenregionen SE-Kenias: Eine Untersuchung Mittels bodenmikrobiologischer Feld- und Labormethoden. Diplomarbeit, Universitaet Trier, 140pp.
- Forster J.C. 1995a. Soil nitrogen. In: Alef, K., and Nannipieri, P. (Eds.) *Methods in Applied Soil Microbiology and Biochemistry*. Academic Press, London, pp. 79–87.
- Forster J.C. 1995b. Soil phosphorus. In: Alef, K., Nannipieri, P. (Eds.), *Methods in Applied Soil Microbiology and Biochemistry*. Academic Press, London, pp. 105–117.
- Giller K.E. and Wilson K.J. 1991. *Nitrogen Fixation in Tropical Cropping Systems*. CAB International, Wallingford, U.K.
- Gitonga N.M., Shisanya C.A., Maingi J.M. and Hornetz B. 1999. Nitrogen fixation by *Vigna radiata* L. Wilczek in pure and mixed stands in Southeast Kenya. *Symbiosis* 27: 239–250.
- Hardarson G., Danson S.K.A., Zapata F. and Reichardt K. 1991. Measurements of nitrogen fixation in fababean in different N fertilizer rates using ^{15}N isotope dilution and “A-value” methods. *Plant and Soil* 131: 161–168.
- Hornetz B., Shisanya C.A. and Gitonga N.M. 2000. Studies on the ecophysiology of locally suitable cultivars of food crops and soil fertility monitoring in the semi-arid areas of southeast Kenya. *Materialien zur Ostafrika-Forschung, Heft Nr. 23*. Universitaet Verlag, Trier.
- Hornetz B. 1997. *Resourcenschutz und Ernährungssicherung in den semiariden Gebieten Kenyas*. Reimer Verlag, Berlin.
- Hornetz B. 1990. Vergleichende Stressphysiologie von Tepary Bohnen als ‘Minor crop’ und Mwezi Moja Bohnen als Hochleistungsleguminose im tropischen Landbau. *J. Agron. Crop Sci.* 164: 1–15.
- Inrugu J.W., Wood M., Okalebo J.R. and Warren G.P. 2002. Enhancement of biological nitrogen fixation input in smallholder farms in semi-arid Kenya through application of phosphorus fertilizer. In: Karanja N.K., and Kahindi J.H.P. (Eds.) *Proceedings of the 9th Congress of AABNF, 25–29th September 2000, Nairobi*, pp.306–323.
- Jaetzold, R., Schmidt, H., 1983. *Farm management handbook of Kenya*. Vol. II. GTZ and Ministry of Agriculture, Eschborn and Nairobi.
- Kerley S.J. and Jarvis S.C., 1999. The use of nitrogen-15 natural abundance in white clove (*Trifolium repens* L.) to determine nitrogen fixation under different management practices. *Biol. Fert. Soils* 29: 437–440.
- Kibunja C.N. 1984. Agricultural residues as Rhizobia carriers in Kenya. In: Ssali, H. and Keya, S.O. (Eds.) *Proceedings of the First Conference of the African Association for Biological Nitrogen Fixation (AABNF) in Africa, 23–28 September, Nairobi*, pp 160–172.
- Kohl D.H., Shearer G. and Harper J.E. 1980. Estimates of N_2 fixation based on differences in the natural abundance of ^{15}N in nodulating and non-nodulating isolines of soybeans. *Plant Physiol.* 66: 61–65.
- Maingi J.M., Shisanya C.A., Gitonga N.M. and Hornetz B. 2001. Nitrogen fixation by common bean (*Phaseolus vulgaris* L.) in pure and mixed stands in semi-arid south-east Kenya. *European J. Agron.* 14: 1–12.
- Pilbeam C.A., Wood M., and Mugane P. G. 1995. Nitrogen use in maize-grain legume cropping systems in semi-arid Kenya. *Biol. Fert. Soils* 20: 57–62.
- Porter L.K. and O’Deen W.A. 1977. Apparatus for preparing nitrogen from ammonium chloride for nitrogen-15 determinations. *Analyt. Chem.* 49: 514–516.
- Rao M.R., and Mathuva M.N. 2000. Legumes for improving maize yields and income in semi-arid Kenya. *Agric., Ecosys. Env.* 78: 123–137.
- Republic of Kenya, 1993. *National Development Plan 1993–96*. Government Printer, Nairobi.
- Shisanya C.A. 2004. Improvement of grain legume production in semi-arid Kenya through biological nitrogen fixation: The experience with tepary bean (*Phaseolus acutifolius* A. Gray var. Latifolius). In: Dris R. and Jain S.M. (Eds.) *Production Practices and Quality Assessment of Food Crops. Vol. 1: Preharvest Practices*. Kluwer Academic Publishers, Dordrecht, The Netherlands, pp. 163–188.
- Shisanya C.A. 2002. Improvement of drought adapted tepary bean (*Phaseolus acutifolius* A. Gray var. latifolius) yield through biological nitrogen fixation in semi-arid SE-Kenya. *European J. Agron.* 16: 13–24.
- Shisanya C.A. 1999. Farming systems characteristics in semi-arid SE-Kenya: resource base, production dynamics and the way forward. *Chem Chemi* 1: 56–74.
- Shisanya C.A. 1998. Phenology and diurnal course of leaf water potential of three bean varieties under a semi-arid environment in southeast Kenya. *E. Afric. J. Sci.* 1: 11–19.
- Steel R.D.G. and Torrie J.H. 1981. *Principles of Statistics: A Biometrical Approach*. 2nd Edition. McGraw-Hill, London.
- Shisanya C.A. 1996. Chances and risks of maize and bean growing in the semi-arid areas of SE-Kenya during expected deficient, normal and above normal rainfall of the short rainy seasons. *Materialien zur Ostafrika-Forschung, Heft 14*. 418pp.
- Tiffen M., Mortimore M. and Gichuki F. 1994. *More People, Less Erosion*. ACTS Press, Nairobi.

Evaluation of cowpea genotypes for variations in their contribution of N and P to subsequent maize crop in three agro-ecological zones of West Africa

R.C. Abaidoo^{1*}, J.A. Okogun¹, G.O. Kolawole¹, J. Diels¹, P. Randall², and N. Sanginga^{1,3}

¹International Institute of Tropical Agriculture (IITA), Oyo Road, PMB 5320, Ibadan, Nigeria, Mailing address: c/o L.W. Lambourn & Co., Carolyn House, 26 Dingwall Road, Croydon CR9 3EE, England; ²Commonwealth Scientific and Industrial Research Organization (CSIRO) Plant Industry, GPO Box 1600, Canberra, ACT, 2601, Australia; ³present address, Tropical Soil Biology and Fertility, Institute of CIAT, P.O. Box 30677, Nairobi, Kenya; *Corresponding author E-mail: r.abaidoo@cgiar.org, Tel: +234-(0)2-241 2626 ext 2300

Abstract

Cowpea is an important source of food, cash, and fodder in West Africa. It is perceived to be tolerant to low available soil phosphorus (P) conditions and nodulates promiscuously contributing to soil fertility through its high nitrogen (N)-fixing capacity. Cowpea can contribute substantial amounts of N to a subsequent cereal crop but little is known of the effect of cowpea on P nutrition of a cereal crop grown in rotation. This study, therefore evaluated eight cowpea genotypes for N₂ fixation, tolerance to low soil P (0P), and response to P fertilizer application (90 kg P ha⁻¹ as Rock Phosphate (RP) or 30 kg P ha⁻¹ as Triple Superphosphate (TSP)), and their potential contribution of N and P to a subsequent maize crop in three agroecological zones (at Shika, northern Guinea savanna; at Fashola, derived savanna; and Davié, coastal savanna). Grain yield and P uptake of cowpea genotypes were influenced by location. Relative response of cowpea genotypes to P application was highest at Shika where soil resin P content was lowest. The responses to RP application across locations ranged from -14 to 94%; and 194 to 358% for TSP application. Variation between genotypes was minimal within the 0P and RP treatments but more pronounced within the TSP treatment at all the locations. The results showed that N₂ fixation, N exported in grain, and N balances of cowpea genotypes were different depending on P nutrition conditions. Grain yield of maize following cowpea was influenced largely by the previous cowpea genotype through its N and P dynamics, location, and VAM colonization of roots. There was, however, no consistent evidence of a significant effect of P applied to the legume, on the residual value to the subsequent maize crop.

Key words: Cowpea, Maize, Nitrogen fixation, Phosphorus efficiency, Rotation

Introduction

Cowpea is widely cultivated in the drier regions of West Africa and is found in rotation, strip cropping, relay cropping, and intercropping systems with other legumes and non-legumes, or as a mono-crop. It plays an important role in the livelihood of millions of people as a source of food, cash, and fodder for livestock. Cowpea also plays an important role in the nutrient economies of these cropping systems by reducing the

need for N fertilizers through biological nitrogen fixation (BNF). Estimates of the benefits of cowpea to soil N supply in the savanna through BNF range from 60 to 80 kg N ha⁻¹, depending on how the residues are managed (Dakora et al. 1987; Horst and Härdter 1994). Lower, and even negative values have also been reported (Awonaike et al. 1990; Sanginga et al. 2000).

Cowpea is a common component of the intensified cropping systems being adopted in the derived and the Guinea savanna where the crop is relied upon to fix N

and improve soil fertility. However, the BNF process has a high requirement for P (Vance 2001), yet many soils in this region have a bicarbonate-extractable P content of less than 8 ppm (Mokwunye et al. 1986). Consequently, unless the P nutrition is improved, the full potential of cowpea to the nitrogen economy of soil may not be realized, and there is a risk that cowpea based cropping systems will fall short of expectations as integrated soil fertility management options in many parts of the savanna.

One approach to improving crop P nutrition is through better P acquisition efficiency, and there is evidence that legume genotypes may have developed various strategies to take up P from sparingly soluble sources (Marschner 1998; Bagayoko et al. 2000). The potential therefore exists for the identification of cowpea genotypes that are productive under relatively low soil P fertility conditions or are better able to extract residual P or to use applied P fertilizers more efficiently, particularly sparingly soluble fertilizers. Successful identification and use of such genotypes in prevalent cropping systems will improve P nutrition of the legume and possibly also the non-legume components.

Unlike the situation with N, the contribution of cowpea to soil P availability, and its subsequent use by cereals has not been extensively studied in the West African moist and derived savanna. Sanginga et al. (2000) observed large differences among cowpea genotypes in their P requirements for growth and N₂ fixation at a site in derived savanna in southern western Nigeria, but suggested further testing to examine the effects on the soil P status and P nutrition of subsequent crops. The objectives of the study were (i) to evaluate eight cowpea genotypes in three savanna environments (northern Guinea, derived, and coastal) for inter-genotypic variations in N₂ fixation, tolerance to low P, and response to P fertilizer application (90 kg P ha⁻¹ as Rock Phosphate and 30 kg P ha⁻¹ as TSP), and (ii) to assess their contribution of N and P to the subsequent maize crop.

Materials and methods

Study sites

The field experiments were conducted at Fashola and Shika in Nigeria, and Davié in Togo during 2001, 2002 and 2003. Fashola (7°50'N, 3°55'E; soil type, Ferric Luvisol) is located in the derived savanna of southern western Nigeria and has a bimodal rainfall pattern with

about 1200 mm rainfall per annum. Shika (11°13' N, 7°12' E; soil type, Haplic Lixisol) is located in the northern Guinea savanna (northern Kaduna State, Nigeria) and has a unimodal rainfall pattern with about 1100 mm rainfall per annum. Davié (6° 23'N, 0°50'E; soil type, Rhodic Ferralsol) is located in the coastal savanna of Togo with a mean annual rainfall of 1000 mm.

Soil characteristics

Soil chemical characteristics determined at the beginning of the trials included pH (1:1, soil:H₂O), available P and exchangeable bases (in Mehlich-3 solution at pH 2.5), using standard laboratory procedures (IITA 1989). In addition, sequential P fractionation was done using the modified Hedley's procedure, as described by Tiessen and Moir (1993), and the P in the solution was measured by the method of Murphy and Riley (1962). Available P (Olsen P) in previous legume plots was measured at maize planting.

Experimental layout, planting and crop management

Fields were cleared at the three locations, ploughed and ridges spaced 75 cm apart were constructed with a tractor-mounted ridger. The plot sizes were 4 m x 4 m with 1 m gap between plots, 1.5 m between treatments, and 2 m between replications.

The experiment was laid out as a split plot design with four replications. The treatments consisted of three P treatments (nil (0P), 30 kg P ha⁻¹ as triple superphosphate (TSP) and 90 kg P ha⁻¹ as rock phosphate (RP) applied on the main plots; and eight cowpea genotypes (Dan-ila, IT82D-716, IT82D-849, IT86D-715, IT89KD-374, IT89KD-349, IT89KD-391, IT90K-59), and one maize genotype (Oba Super 1) grown on the sub-plots. Both the cowpea and maize genotypes were obtained from the germplasm collection of IITA, Ibadan, Nigeria. Both species were sown at four seeds per hole at 25 cm spacing and thinned to one plant at 2 weeks after planting (WAP). The plots were weeded manually using hoes and plants were sprayed periodically, with Karate insecticide from 4 WAP until late podding stage, to control pod borers (*Maruca testularis*), aphids, (*Aphis craccivora*), and thrips (*Megalurothrips sjostedti*).

An early harvest was made at 50% podding stage (R3.5) for cowpea (Fehr et al. 1971) to estimate shoot

biomass, vesicular arbuscular mycorrhiza (VAM) colonization of roots, percentage N derived from N_2 fixation (%Ndfa), and total N and P uptake. The colonization of roots by VAM was estimated using the method of Giovannetti and Mosse (1980) after staining and clearing following the procedure of Philips and Hayman (1970). The %Ndfa was estimated by determining the concentrations of ureides in xylem sap at cowpea podding stage ($R_{3.5}$), as described by Peoples et al. (1989). The amount of N fixed (N_f) was estimated from %Ndfa and the amount of N in the crop at the same growth stage. The net contribution of N_2 fixation to the N balance in the soil was estimated using the equation proposed by Peoples and Craswell (1992): Net N balance = $N_f - N_g$, where N_g is the total N in the grain.

Harvesting was done at physiological maturity to estimate grain yield and total N and P exported in the grain. Harvested plants were weighed and subsamples of shoots and grain were oven dried at 65°C for seven days for dry weight determination, and were then ground and analysed for total N and P using an autoanalyser following wet acid digestion (IITA 1989).

The effects of the cowpea genotypes and P applied in 2001 and 2002 on the subsequent maize crop were determined in 2002 and 2003. In 2003, the previous OP plots were split into two; one half received 15 kg P ha⁻¹ as a fresh addition of TSP while the other half did not. Weeds that had grown in the previous crop cycle or during the fallow period were cut and cleared by hand ensuring that remaining legume residues were not dislodged from their original plots. Soil samples (0–10 cm) from the individual cowpea and maize plots were analysed for changes in pH, Olsen P content, and P fractions, before maize was planted. Four seeds of maize (Oba Super I) were sown at 75 cm x 25 cm spacing in the previous cowpea and maize plots and the seedlings were later thinned to one plant per stand at 2 WAP. The maize plots received the same management as the cowpea crop cycle plots except for the use of insecticide. Five plants were randomly harvested from the two middle rows at 8 WAP for estimation of VAM infection, and total tissue N and P, while 7 m² of the harvest (two inner) rows were harvested at physiological maturity for grain yield and determination of total N and P exported in grain.

Statistical analysis

Data collected were combined over two years for each location and analysed using the mixed model ANOVA

procedure of SAS (Littel et al. 1996). In this model, P source and genotype were considered as fixed effects and replications as random effects. Data collected for maize in rotation were analysed separately for each year since treatments for the years were not the same. Treatment means were separated using standard error of the mean.

Results

Soil physico-chemical characteristics

The pH of the field sites ranged from 5.5 (Davié) to 6.50 (Shika) while the exchangeable cations were lowest at Fashola and highest at Davié (Table 1). The resin-extractable P (mg P kg⁻¹, mean of two years) was 1.6 at Shika, 2.4 at Fashola and 5.4 at Davié. The comparable values for readily available P (sum of the labile fractions) ranged from 10 mg P kg⁻¹ at Fashola to 15 mg P kg⁻¹ at Davié. The NaOH-Po fraction ranged from 22.6 mg P kg⁻¹ at Fashola to 37.7 mg P kg⁻¹ at Davié and was the largest fraction in the labile plus moderately labile pool, comprising about 60% of this pool in each soil.

The first crop phase

Grain yield of cowpea and response to P

The grain yield of cowpea was considerably lower at Shika, the driest site, than at Fashola or Davié, probably reflecting the effect of differences in rainfall. Inter-genotypic variation was slight within the OP and RP treatments but this was more pronounced with the TSP application in all locations. Grain yield differences among genotypes within the OP treatments were not significant at Shika and Fashola, but at Davié, the grain yield of IT86D-715 was significantly higher than of Dan-ila, IT82D-716, IT89KD-374, and IT89KD-391, while IT82D-716 produced significantly lower yields than IT89KD-849, IT89KD-349, and IT90K-59 (Table 2).

Relative grain yield response of cowpea genotypes to P application was highest at Shika where soil resin P content was lowest (Table 1). At this location, grain yield responses to RP application ranged from 14 to 94%, and from 194 to 358% in response to TSP application. Responses to RP and TSP applications at the two other locations were lower and ranged from 0 to 15% for RP and from 20 to 53% for TSP. Cowpea

Table 1. Physico-chemical characteristics of top soil (0–15 cm) from the three locations, sampled in 2001 prior to sowing of the first (cowpea) crop phase. At each location, the sites used in 2001 and 2002 were adjacent

Soil characteristics	Fashola		Shika		Davié	
	2001	2002	2001	2002	2001	2002
pH (H ₂ O)	6.3	6.0	6.3	6.5	5.5	6.0
Soil texture (g kg⁻¹)						
Sand	670	730	790	790	430	450
Silt	220	100	100	100	400	380
Clay	110	170	110	110	170	170
Exchangeable cations (c molc kg⁻¹)						
Ca	2.0	1.7	2.1	1.9	3.2	3.1
Mg	0.8	1.0	1.5	1.3	2.2	2.0
K	0.2	0.3	0.2	0.2	0.8	0.4
P fractions (mg kg⁻¹)						
<i>Labile</i>						
Resin-P	3.2	1.5	0.7	2.5	6.9	3.8
HCO ₃ -Pi	3.2	0.8	2.6	3.8	4.6	1.5
HCO ₃ -Po	4.1	7.1	4.3	9.2	5.0	8.2
<i>Moderately labile</i>						
NaOH-Pi	7.3	3.6	7.2	10.5	10.4	10.0
NaOH-Po	27.7	17.5	27.1	34.3	38.8	36.6
<i>Ca bound</i>						
1M HCl	2.7	3.7	2.0	4.6	5.4	13.5
<i>Stable</i>						
Conc. HCl-Pi	27.4	6.0	26.2	8.9	23.8	17.3
Conc. HCl-Po	1.0	5.4	22.2	5.9	6.9	11.1
Residual P	15.3	10.0	31.5	48.7	31.5	32.9
Total P	91.6	55.6	123.6	128.4	133.2	134.8

Table 2. Grain yield (kg ha⁻¹) of cowpea genotypes grown at three locations without P or with P applied as RP or TSP¹

Genotype	Location											
	Shika				Fashola				Davié			
	OP	RP	TSP	Mean	OP	RP	TSP	Mean	OP	RP	TSP	Mean
Dan-ila	167	224	510	301	791	880	1010	894	668	655	968	763
IT82D-716	159	193	468	273	652	721	998	791	498	410	600	503
IT89KD-849	163	186	528	292	792	868	1039	900	880	840	1145	955
IT86D-715	213	355	768	445	684	693	968	782	1013	905	1090	1002
IT89KD-349	172	270	607	350	879	914	1054	949	868	720	675	754
IT89KD-374	150	207	530	296	800	797	1129	909	760	863	873	832
IT89KD-391	198	314	745	419	784	835	959	860	593	570	595	586
IT90K-59	166	322	761	416	860	990	1244	1031	940	915	1230	1028
Mean	173	259	614		780	838	1050		777	744	897	
SEM²												
P source	15				38				28			
Genotype	25				65				45			
P×Genotype	43				107				78			

¹Data represent means across 2001 and 2002, and ²SEM, the standard error of the mean.

genotypes IT90K-59 and IT86D-715 had the highest grain yield response to both RP and TSP at Shika and Fashola while IT89KD-374 and IT90K-59 gave positive responses to RP at Davié. The cowpea genotype IT82D-716 produced the lowest grain yield response to RP and TSP at Shika and was among the genotypes with lowest response to P application at Fashola and Davié.

Total P exported in cowpea grain

The application of TSP significantly increased grain P content in all cowpea genotypes at all locations except for a few genotypes in Davié. The percentage increases in grain P content ranged from 234 to 386 at Shika, from 23 to 66 at Fashola, and from 11 to 69 at Davié. The increases in grain P content due to PR application were not significant at Fashola and Davié, but a few genotypes (e.g., IT86D-715, IT89KD-391 and IT90K-59) accumulated higher P from RP than the corresponding OP treatments (Table 3).

N fixation and N balance

Phosphorus fertilizer application significantly enhanced N₂ fixation at Shika but not at the other two locations. The mean percentage N derived from the atmosphere (%Ndfa) within the OP treatment was increased by 18% with RP application and by 26% with TSP application (Figure 1). Variations between genotypes

were, however, more pronounced. The %Ndfa by Dan-ila, IT89KD-349, and IT89KD-374 at Shika was significantly greater than that of IT82D-716 in the OP treatment. Within the TSP treatments, %Ndfa by IT82D-716 and IT89KD-849 was significantly lower than that measured for Dan-ila, IT89KD-349, and IT89KD-374.

Application of TSP increased total N accumulation in shoot biomass at mid podding stage (R3.5). Increases over OP treatments were 32% at Davié, 69% at Fashola, and 294% at Shika (Table 4). Variations among genotypes within the OP and RP treatments at all locations were not significant but the differences among some genotypes within TSP treatments at Shika and Davié were significant. At Shika, for example, the N accumulation of 145 kg ha⁻¹ for IT82D-715 was significantly higher than the 77 kg N ha⁻¹ accumulated in IT89D-374, while at Davié, N accumulation of 133–138 kg ha⁻¹ measured for IT82D-716, IT82D-715, and IT89D-391 was significantly higher than the 85 kg N ha⁻¹ of IT89D-849.

The N contribution to the subsequent maize crop (N balance) was significantly improved with TSP but not with RP application in all the locations. At Shika, mean N balance across genotypes within the TSP treatment was 31.7 kg ha⁻¹ compared to the 1.8 kg ha⁻¹ and 6.1 kg ha⁻¹ for the OP and RP treatments, respectively (data not shown). Similarly, TSP application at Fashola resulted in a mean N balance of 27.9 kg ha⁻¹

Table 3. Total P exported in grain (kg ha⁻¹) of cowpea genotypes grown at three locations under low and high P conditions¹

Genotype	Location											
	Shika				Fashola				Davié			
	OP	RP	TSP	Mean	OP	RP	TSP	Mean	OP	RP	TSP	Mean
Dan-ila	0.58	0.83	1.94	1.12	2.66	2.94	4.17	3.26	2.31	2.43	3.91	2.88
IT82D-716	0.61	0.75	2.19	1.18	2.54	2.98	4.73	3.41	2.09	1.81	3.12	2.34
IT89KD-849	0.46	0.56	1.73	0.92	3.45	3.92	4.87	4.08	3.33	2.63	5.20	3.72
IT86D-715	0.66	1.19	2.62	1.49	3.17	3.37	4.88	3.80	3.53	3.14	4.66	3.78
IT89KD-349	0.57	0.98	2.24	1.27	3.32	3.21	4.10	3.54	3.18	2.40	2.82	2.80
IT89KD-374	0.45	0.70	1.98	1.04	3.48	3.39	4.82	3.90	2.77	2.95	3.35	3.02
IT89KD-391	0.72	1.10	2.82	1.55	2.58	2.99	4.27	3.28	2.54	2.40	3.26	2.74
IT90K-59	0.56	1.14	2.72	1.48	3.18	3.73	4.74	3.88	3.45	3.15	4.71	3.77
Mean	0.58	0.91	2.28		3.05	3.32	4.57		2.90	2.62	3.89	
SEM ²												
P source	0.06				0.20				0.15			
Genotype	0.09				0.33				0.25			
P × Genotype	0.16				0.58				0.43			

¹Data represent means across 2001 and 2002, and ²SEM, the standard error of the mean.

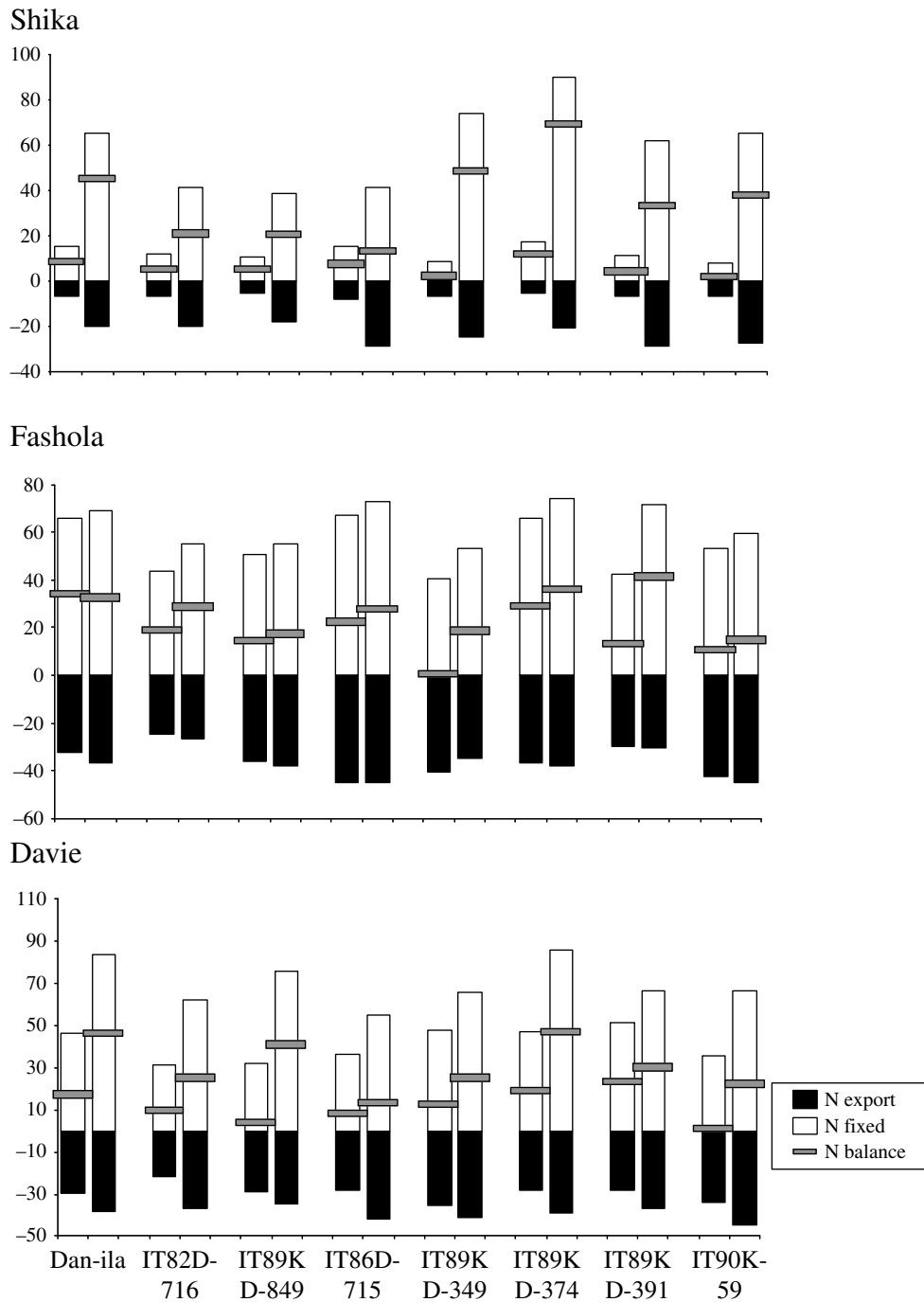

Figure 1. Nitrogen fixation, N exported in grain, and N balance of cowpea genotypes grown at three locations with no added P or with 30 kg P ha⁻¹ (as TSP). For each pair of bars, the left represents low-P and the right, the high-P (30 kg P ha⁻¹) condition.

Table 4. Total N (kg ha⁻¹) in shoot biomass at R3.5 growth stage of cowpea genotypes grown at three locations without P or with P applied as TSP or RP

Genotype	Location											
	Shika				Fashola				Davié			
	OP	RP	TSP	Mean	OP	RP	TSP	Mean	OP	RP	TSP	Mean
Dan-ila	28.3	49.0	106.6	61.3	70.7	94.5	126.9	97.4	97.4	103.4	125.1	108.6
IT82D-716	34.3	45.8	120.2	66.8	56.5	74.9	94.5	75.3	86.5	115.8	133.1	111.8
IT89KD-849	28.3	41.4	107.9	59.2	59.5	61.8	151.3	90.9	72.8	90.6	85.4	82.9
IT86D-715	34.2	36.1	144.8	71.7	70.3	64.7	99.0	78.0	108.6	107.9	133.4	116.6
IT89KD-349	15.6	36.8	89.9	47.4	76.9	69.4	101.9	82.7	76.8	98.4	98.6	91.3
IT89KD-374	31.2	36.7	76.6	48.2	77.8	59.4	133.8	90.3	88.9	108.1	106.0	101.0
IT89KD-391	20.9	47.6	104.3	56.6	73.3	83.7	108.1	88.4	94.5	121.6	137.6	117.9
IT90K-59	18.9	26.7	84.6	43.4	66.7	88.4	118.0	91.0	86.1	91.9	119.9	99.3
Mean	26.5	40.0	104.4		69.0	74.6	116.7		88.9	104.7	117.4	
SEM												
P source	6.92				8.44				5.43			
Genotype	11.31				13.79				8.78			
P × Genotype	19.58				23.88				15.15			

¹ Data represent means across 2001 and 2002, and ²SEM, the standard error of the mean.

compared to 7.2 kg ha⁻¹ for OP and 7.9 kg ha⁻¹ for the RP treatment. Variation among genotypes was also location-specific. For example, Dan-ila and IT82D-715 had significantly higher N balances than IT90K-59 at Shika within the TSP treatments (Figure 1), but the N balance estimated for IT89D-849 was significantly higher than those of IT82-715 and IT90K-59 at Fashola.

Olsen P concentration in soil of plots previously sown to cowpea genotypes

Olsen P contents of previous (2001) P treatment plots measured in 2003 (at maize planting) varied significantly at Davié, but not at Fashola (the 2001 Shika plots were lost in 2002, and therefore unavailable for sampling in 2003). However, differences among previous cowpea genotype plots within the P treatments were not significant. The ranges of Olsen-P values (mg P kg⁻¹ soil) measured from the previous P treatment plots at Davié were: OP, 2.3–4.0; RP, 3.1–5.0; and TSP, 4.0–8.8; and at Fashola were: OP, 2.9–5.3; RP, 3.3–5.5; and TSP 2.6–5.3. Similar trends were observed for the previous 2002 legume × P treatment plots sampled in 2003. At Shika and Davié, mean Olsen P contents (mg kg⁻¹ soil) of previous TSP plots (Shika, 7.1; Davié, 7.30) were significantly higher than that of the previous RP (Shika, 4.2; Davié, 4.5), and OP (Shika, 3.3; Davié, 3.6) plots. At Fashola, mean values for OP (3.8),

RP (4.4), and TSP (3.7) were not significantly different. Differences between previous cowpea genotype plots within the same P treatment were not significant at any of the locations.

The second crop phase

Grain yield of maize grown after cowpea

In 2002, mean maize grain yields across plots previously planted to cowpea genotypes were generally low and ranged from 1086 to 2069 kg ha⁻¹ but the mean maize grain yield after pooling data for all genotypes in response to previous TSP application was significantly higher than the mean yields from the previous RP treatment. Grain yields from previous OP treatments were also significantly higher than those from the RP treatment but were comparable to yields from previous TSP plots at Fashola (data not shown). In Fashola, mean maize grain yield was influenced by the previous cowpea genotype treatment but only the differences between maize grain yields from previous Dan-ila, and IT89KD-391, and the previous maize plot were significant within the previous TSP plots. Mean total N and P exported in the grain of maize grown in previous OP and TSP plots were significantly higher than N and P exported from previous RP plots at Fashola but not at Davié (data not shown).

Table 5. Grain yield (kg ha^{-1}) of maize grown in 2003 following cowpea genotypes or maize grown in 2002. P treatments were 0P or a current application of 15 kg P ha^{-1} or residual P from RP or TSP applied in 2002

Previous crop	Location											
	Shika				Fashola				Davié			
	0P	15 kg P	RP	TSP	0P	15 kg P	RP	TSP	0P	15 kg P	RP	TSP
<i>Cowpea</i>												
Dan-ila	1669	3004	2110	2115	700	1110	1260	1018	3120	3152	2839	3721
IT82D-716	1025	2503	1795	1820	1219	1807	1593	1522	2547	3051	3067	3082
IT89KD-849	1063	2501	2271	2265	1116	1204	972	1539	1978	2310	2419	2885
IT86D-715	909	2649	1668	2275	1100	1261	1406	1372	2906	3166	2527	3315
IT89KD-349	587	1820	1850	2057	1217	1533	1347	1222	2515	3396	2850	3348
IT89KD-374	717	2041	1778	1807	808	1318	1189	1210	2428	3167	2684	2873
IT89KD-391	975	2171	1744	2298	875	1116	1146	1249	2507	3800	2502	2525
IT90K-59	756	1982	2171	2013	1253	1683	1410	934	2394	3332	2478	3125
Maize	449	1544	1632	1422	729	940	1063	1136	2646	3068	3267	2637
Mean	906	2246	1891	2008	1002	1330	1265	1245	2560	3160	2737	3057
SEM ¹												
P source	97				81				115			
P × Genotype	292				245				344			

¹ SEM: standard error of the mean.

Maize grain yields (from previous 2001 cowpea and maize plots) from the 0P and TSP plots were generally higher than yields from previous RP plots at Fashola but not at Davié (data not shown). Also, differences between maize grain yield from previous cowpea genotypes and maize plots were significant ($P < 0.05$) only for the Dan-ila–RP plot and IT89KD-391-TSP plot at Fashola. The fresh addition of 15 kg P ha^{-1} at planting did also significantly improve maize grain yields over the yields from the previous P treatments at Fashola.

The application of 15 kg P ha^{-1} to the 2002 cowpea plots increased maize grain yields over yields from previous 0P plots within the range of 18–95% at Shika, 18–92% at Fashola, and 3–24% at Davié (Table 5). At Shika, mean maize yields from previous 0P plots were significantly lower than those from the previous RP and TSP plots. At Fashola, mean maize yields from previous RP and TSP plots were significantly higher than yields from the previous 0P plots but the addition of 15 kg P ha^{-1} made no significant contribution to yield increases in previous 0P plots, as observed at Shika. The effect of previous cowpea genotypes and the fresh addition of 15 kg P ha^{-1} on grain yield of maize followed no consistent pattern across the locations. For example, at Shika, the addition of 15 kg P ha^{-1} resulted in a significantly higher grain yield from previous 0P plots for Dan-ila, IT82KD-716, IT89KD-849, and IT86KD-715 compared with yields from the previous maize plot.

Total N and P in grain of maize grown after cowpea

Total grain N and P from previous (2002) TSP plots and the plots that received the 15 kg P ha^{-1} were significantly higher than the 0P yields at Shika and Fashola but not at Davié (Data not shown). Percentage increases in total N in maize grain following cowpea genotypes over that of maize following maize ranged from –12 to 341 at Shika, –22 to 134 at Fashola and –22 to 49 at Davié (Figure 2). With respect to residual P benefits, percentage increases over that of maize after maize ranged from –13 to 226 at Shika, –41 to 212 at Fashola, and –10 to 76 at Davié. Despite these gains, there were only a few isolated instances where total maize grain N and P contents from previous cowpea genotype plots were significantly higher than from previous maize plots, but this was not consistent across the locations and within P treatments.

Mycorrhizal infection of maize roots following cowpea

Percentage VAM infection of roots of maize grown in previous 0P and TSP treatment plots was generally higher than those from the previous RP plots while the fresh application of 15 kg P ha^{-1} resulted in significant suppression of VAM infection of maize roots (Table 6). The effect of previous cowpea genotype on VAM infection of the root of the subsequent maize crop

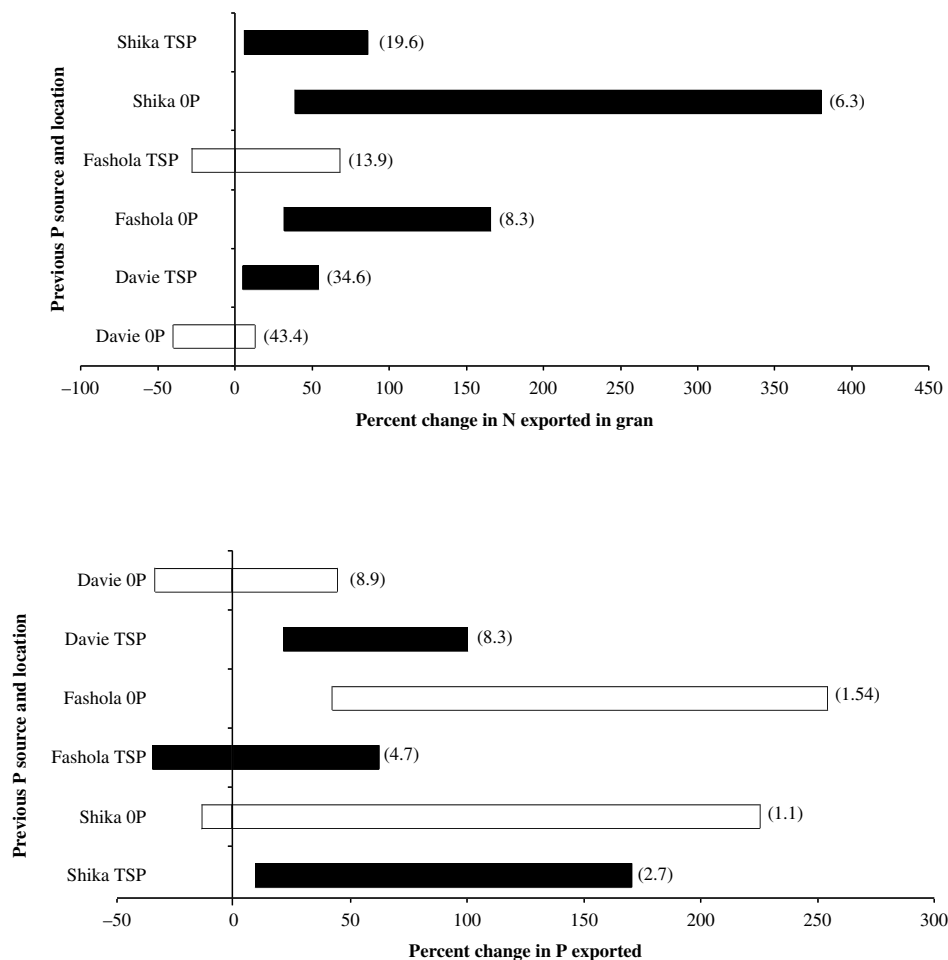

Figure 2. Gains in total N and P in grains of maize grown after cowpea genotypes over maize after maize. Figures in parenthesis represent absolute N and P contents of grain of maize grown after maize.

was also inconsistent but higher infection rates were more commonly associated with previous OP plots in all the locations.

Discussion

The available P data indicated that the sites selected were low in soil available P. The NaOH-Po fraction was, however, large indicating that it may potentially serve as an available P source upon mineralization (Kolawole et al. 2003). However, this depends on other soil factors and the capability of the legume plants to use this sparingly available source readily. The Olsen P contents of previous cowpea treatment plots measured during the maize crop cycle suggest that much of the TSP applied during the legume cycle was utilized

by the cow pea crop and amounts from the expected release and accumulation of P from the RP were not substantial due to the low solubility of RP.

Despite its reputation for tolerance to low P, cowpea has shown good response to external P application (Sanginga et al. 2000; Ahloowalia et al. 1995). This has been attributed to inherent low availability of soil P in the locations used and the high demand by legumes for P for N₂ fixation. Cowpea breeding programmes in Africa advocate genotypes that are capable of producing high yields under low soil P conditions. The variety IT90K-59, relative to the others in this study, invariably meets this requirement and would fit well in other cropping systems such as, in rotation with previously fertilized maize.

The differential responses of cowpea genotypes to applied P were also reflected in the amount of P

Table 6. VAM colonization (%) of roots of maize in 2003 following cowpea genotypes or maize grown in 2002. P treatments were 0P or a current application of 15 kg P.ha⁻¹ or residual P from RP or TSP applied in 2002

Previous crop	Location											
	Shika				Fashola				Davié			
	0P	15 kg P	RP	TSP	0P	15 kg P	RP	TSP	0P	15 kg P	RP	TSP
Cowpea												
Dan-ila	41.2	4.1	15.9	32.2	41.8	3.5	5.7	21.8	24.4	5.0	13.2	32.8
IT82D-716	41.8	1.7	12.8	38.4	42.7	7.0	12.7	12.9	51.5	4.6	5.5	26.2
IT89KD-849	47.6	3.1	34.6	43.0	41.4	5.5	3.4	32.3	23.3	5.8	8.5	31.8
IT86D-715	48.4	2.5	17.2	41.0	20.9	6.1	12.6	31.1	30.3	5.7	1.9	22.1
IT89KD-349	36.8	3.1	25.1	39.9	42.6	8.0	11.5	27.4	23.3	3.7	5.3	27.5
IT89KD-374	49.5	3.5	15.9	24.9	42.6	7.3	1.0	23.4	33.9	1.3	7.8	32.0
IT89KD-391	33.2	4.4	19.2	31.9	28.2	8.1	4.2	29.5	41.0	2.5	5.5	34.7
IT90K-59	43.9	3.2	37.3	41.5	37.1	1.7	1.1	25.2	30.1	1.8	6.4	19.2
Maize	44.5	4.4	28.7	46.4	44.5	6.0	5.9	28.1	31.5	5.8	17.7	29.6
Mean	43.0	3.3	23.1	37.7	38.0	5.9	6.6	25.9	31.4	4.0	11.0	28.4
SEM ¹												
P source	0.45				0.34				0.45			
P × Genotype	1.35				1.03				1.50			

¹SEM, the standard error of the mean

exported in grain. The total P exported in the grain of the responsive cowpea genotype IT90K-59 was higher than the uptake in the inefficient non-responsive IT82D-716 in almost all the P treatments (data not shown). This suggests that IT90K-59 may not be a suitable candidate when considering cowpea genotypes with the potential of enhancing the P nutrition of the cereal crop in rotation, due to its high P export in grain and which may suggest a high P harvest index (PHI). Blair (1993) suggested that an ideal P efficient plant should have low PHI so as to retain more P in straw for subsequent use by less efficient plants in the cropping system. A successful improvement of P availability in cowpea–maize cropping systems in the savannas will require cowpea genotypes efficient in P utilization for high grain and stover productivity for sustained benefits to farmers.

The relatively wide range of %Ndfa recorded for the cowpea genotypes under the various P environments compares with levels reported elsewhere (Eaglesham et al. 1982; Awonaike et al. 1990; Sanginga et al. 2000) but was lower than the maximum reported for cowpea (Peoples and Craswell 1992). BNF was generally increased by P application but this was most pronounced at Shika where initial soil P availability levels were lowest which confirmed the high P requirements for the N₂ fixation process (Vance 2001). However, the moderate increases in %Ndfa resulting from RP and

TSP applications in the other locations may suggest that cowpea genotypes can maintain a high rate of N₂ fixation under moderately low available P conditions. The relatively low response may also be attributed to other nutrient limitations. An interesting observation was that the cowpea genotype IT82D-716 recorded a relatively low N₂ fixation rate at all the locations but its total N accumulation and N balance remained relatively high. This may be attributed to an efficient uptake and use of available soil N and possibly accounts for the low response to P application, as soil N uptake is less dependent on P availability than N₂ fixation.

Nitrogen benefits to cereals through legume cultivation have been attributed to N sparing for the cereal's use, or from mineralization of the N₂ fixed in the legume stover and belowground plant parts (Sanginga et al. 2000). The N balances estimated in this study due to previous cowpea cultivation ranging from -2.6 to 52 kg N ha⁻¹ were lower than values reported elsewhere (Dakora et al. 1987; Horst and Härdter 1994), but higher than some of the estimates reported by Awonaike et al. (1990) and Sanginga et al. (2000). These differences could have been due to the variations among genotypes used in the various studies and, more importantly, to environmental influences such as the population sizes and effectiveness of indigenous rhizobia and soil physico-chemical characteristics.

The significant maize grain yield response to the fresh application of 15 kg P as TSP in some of the locations may corroborate the suggestion by Linquist et al. (1996) that smaller but regular applications of P fertilizer would act as an insurance for maintaining moderate yields and also contribute to the gradual build-up of the soil P capital of tropical soils.

The anticipated benefits of previous cowpea cultivation were characterised by wide variations that could be attributed to cowpea genotype and soil P availability (Figure 1). The ranges of total N and P accumulated in the grain of maize following cowpea genotypes were relatively wide but higher percentage increases over values from maize-after-maize plots were common within OP plots, especially at the Shika location where inherent soil P availability was low. Even though these increases recorded in the three locations are similar to those earlier reported (Dakora et al. 1987), the high incidence of more and even negative gains in maize grown after certain cowpea genotypes calls for thorough evaluations of cowpea genotypes before they are used in rotations with maize in anticipation of positive and significant N and residual P benefits to the maize component. The relatively low grain yield and P accumulation values recorded for maize after the P efficient genotype (IT90K-59) suggest that the use of efficient genotypes may not necessarily lead to P sparing for use by the following cereal crop.

VAM colonization of maize roots was considerably higher in the OP plots than in plots where P had been applied to the maize at sowing and consistent with observations made by Borie et al. (2002) of increased VAM infection in plants under P stress. VAM infection was also low in RP and high in TSP, a surprising result considering that the soil Olsen P values were higher following TSP than following RP, at least at Shika and Davié, and the reason for this is unclear from our data. There is the need for a holistic analysis of the factors that have the potential to interact with N and P availability to limit the full expression of the potential of grain legumes to improve soil fertility and yield stability in low input cowpea–maize cropping systems.

Conclusions

The cowpea genotypes used in the study varied in their efficiency at maintaining high yields under low P conditions, their response to P application, and to maintain N balance for potential use by the subsequent maize. Phosphorus application to cowpea improved the

N contribution to subsequent maize through enhanced N₂ fixation. Unlike N contribution, growth of P efficient cowpea genotypes may not necessarily lead to P sparing effect on subsequent maize growth due to the high P levels exported in grain from system. The fresh application of moderate levels of P rather than dependence on residual P from previous P application would, therefore, be necessary for maintaining yield stability in cowpea–maize rotation systems in sites extremely deficient in P, such as those used at the Shika location.

References

- Ahloowalia B.S., Kumarasinghe K.S., Sigurbjoernsson B. and Maluszynski M. 1995. Genotype selection for improved phosphorus utilization in crop plants. In: Johansen C. Lee K.K., Sharma K.K., Subbarao G.V. and Kueneman E.A. (eds.), Genetic manipulation of crop plants to enhance integrated nutrient management in cropping systems-1. Phosphorus: Proceedings of an FAO/ICRISAT Expert Consultancy Workshop, 15–18 Mar. 1994. ICRISAT Asia Center, Patancheru 502 324, Andhra Pradesh, India: International Crops Research Institute for the Semi-Arid Tropics, pp. 49–54.
- Awonaike K.O., Kumarasinghe K.S. and Danso S.K.A. 1990. Nitrogen fixation and yield of cowpea (*Vigna unguiculata*) as influenced by cultivar and *Bradyrhizobium* strain. *Field Crops Res.* 24: 163–171.
- Bagayoko M., Buerkert A., Lung G., Bationo A. and Römheld V. 2000. Cereal/legume rotation effects on cereal growth in Sudano-Sahelian West Africa: soil mineral nitrogen, mycorrhizae and nematodes. *Plant and Soil* 218: 103–116.
- Blair G. 1993. Nutrient efficiency – what do we really mean? In: P.J. Randall (ed), *Genetic Aspects of Plant Mineral Nutrition*. 1993. Kluwer Academic Publishers, The Netherlands. pp. 205–213.
- Borie F., Redel Y., Rubio R., Rouanet J.L. and Barea J.M. 2002. Interactions between crop residues application and mycorrhizal developments and some soil-root interphase properties and mineral acquisition by plants in an acidic soil. *Biol. Fert. Soils* 36: 151–160.
- Dakora F.D., Aboyinga R.A., Mahama Y. and Apaseku J. 1987. Assessment of N fixation in groundnut (*Arachis hypogea* L.) and cowpea (*Vigna unguiculata* L. Walp) and their relative N contribution to a succeeding maize crop in northern Ghana. *MIRCERN. J.* 3: 389–399.
- Eaglesham A.R.J., Ayanaba A., Rao V.R. and Eskew D.L. 1982. Mineral N effects on cowpea and soybean crops in a Nigerian soil. *Plant Soil* 68: 171–181.
- Fehr W.R., Caviness C.E., Burmood D.T. and Pennington J.S. 1971. Stages of development descriptions for soybeans *Glycine max* (L.) Merrill. *Crop Sci.* 11: 929–931.
- Giovanetti M. and Mosse B. 1980. An evaluation of techniques for measuring vesicular-arbuscular mycorrhizal infection in roots. *New Phytol.* 84: 489–500.
- Horst W.J. and Härdter R. 1994. Rotation of maize with cowpea improves yield and nutrient use of maize compared to maize monocropping in an Alfisol in the northern Guinea savanna of Ghana. *Plant Soil.* 160: 171–183.

- International Institute of Tropical Agriculture (IITA) 1989. Automated and semi-automated methods for soil and plant analysis. Manual series No. 7. IITA, Ibadan, Nigeria.
- Kolawole G.O., Tian, G. and Tijani-Eniola H. 2003. Dynamics of phosphorus fractions during fallow with natural vegetation and planted *Pueraria phaseoloides* in south western Nigeria. *Plant Soil* 257: 63–70.
- Linquist B.A., Singleton P.W., Cassman K.G. and Keane K. 1996. Inorganic and organic phosphorus and long-term management strategies for an Ultisol. *Plant Soil* 184: 47–55.
- Littel R.C., Milliken G.A., Stroup W.N. and Wolfinger R.C. 1996. SAS system for mixed models. Statistical Analysis Systems Inc. Cary, NC., USA. 633pp.
- Marschner H. 1998. Role of root growth, arbuscular mycorrhiza, and root exudates for the efficiency in nutrient acquisition. *Field Crops Res.* 56: 203–207.
- Mokwunye A.U., Chien S.H. and Rhodes E. 1986. Phosphorus reaction in tropical African soils. In: Mukwunye, A.U. and Vlex P.L.G. (eds), Management of nitrogen and phosphorus fertilizers in sub-Saharan Africa. Martinus Nijhoff Publishers, Dordrecht, The Netherlands. pp 253–281.
- Murphy J. and Riley J.P. 1962. A modified single solution method for the determination of phosphate in natural waters. *Anal Chim. Acta* 27: 31–36.
- Peoples M.B. and Craswell E.T. 1992. Biological nitrogen fixation: Investments, expectations, and actual contributions to agriculture. In: Ladha, J.K., George, T. and Bohlool B.B. (eds), Biological Nitrogen Fixation for Sustainable Agriculture. Kluwer Academic Publishers, Dordrecht, The Netherlands. pp 13–40.
- Peoples M.B., Faizah A.W., Rerkasem B. and Herridge D.F. 1989. Methods for Evaluating Nitrogen Fixation by Nodulated Legumes in the Field. ACIAR Monograph No 11, ACIAR, Canberra, Australia. 76 pp.
- Philips J.M. and Hayman D.S. 1970. Improved procedure for clearing roots and staining parasitic and vesicular-arbuscular mycorrhizal fungi for rapid assessment of infection. *Trans. Br. Mycolo. Soc.* 55: 159–161.
- Sanginga N., Lyasse O. and Singh B.B. 2000. Phosphorus use efficiency and nitrogen balance of cowpea breeding lines in a low P soil of the derived savanna zone in West Africa. *Plant Soil.* 220: 119–128.
- Tiessen H. and Moir J.O. 1993. Characterization of available P by sequential extraction. In: Carter, M.R. (ed), Soil Sampling and Methods of Analysis (Chapter 10). Lewis Publishers, Boca Raton, FL. pp. 75–86.
- Vance C.P. 2001. Symbiotic nitrogen fixation and phosphorus acquisition, plant nutrition in a world of declining renewable resources. *Plant Physiol.* 127: 390–397.

Variability of cowpea breeding lines to low phosphorus tolerance and response to external application of Phosphorus

A.K. Saidou¹ R.C. Abaidoo¹, B.B. Singh¹, E.N.O. Iwuafor² and N. Sanginga³

¹International Institute of Tropical Agriculture (IITA), Oyo Road, PMB 5320, Ibadan, Nigeria, Mailing address: c/o L.W. Lambourn & Co., Carolyn House, 26 Dingwall Road, Croydon CR9 3EE, England; ²Institute of Agricultural Research (IAR) Ahmadu Bello University, Samaru, Zaria, Nigeria; ³Tropical Soil Biology and Fertility (TSBF), P.O. Box 30677, Nairobi, Kenya.

Abstract

Cowpea is the most important legume crop in the dry areas of West Africa and features in several cereal-based cropping systems of Sudan and Sahel environments. Low availability of phosphorus is a major constraint to crop production, and efforts are being made to identify crop genotypes with tolerance to low P and greater P use efficiency. Two hundred cowpea genotypes differing in plant type and maturity were evaluated at 3 P levels (0 P, 90 kg P ha⁻¹ as rock phosphate, and 30 kg P ha⁻¹ as SSP) in 2002 at Minjibir, Nigeria and at Toumnia, Niger. The results showed large variations in grain and fodder yields was found among the 200 genotypes. Grain yield response to RP and SSP ranged from 1 to 160%. Based on the performance at low (0 P) and high phosphorus levels (SSP), genotypes were classified into the following groups: i) inherently low yielding at low (0 P) and high P, ii) inherently high yielding at low and high P, iii) low yielding at low P but high yielding at high P, iv) high yielding at low P, but low yielding at high P, and v) inherently moderate yielding. Fifteen genotypes were selected from the different P use and response groups and further evaluated in the greenhouse and field studies for tolerance to low P and response to applied P. In general, application of P increased grain yield, shoot-root ratio but decreased AMF colonization of cowpea roots. There were large differences in P use efficiency and the values ranged from -11 to 38 kg grain (kg P)⁻¹ applied. AMF infection was reduced by at least 50%, while shoot-to-root ratio was significantly increased with P application. Variation between genotypes was significant for certain paired means but not consistent for all parameters measured, and the locations. The cowpea genotypes appeared to differ in AMF colonization, shoot growth relative root development, and relative P use efficiency for tolerance to low P soils and response to external application of P.

Key words: Arbuscular Mycorrhizal Fungi (AMF), Cowpea genotypes, P-tolerance/response, Relative P-use efficiency, Shoot: root ratio

Introduction

Cowpea [*Vigna unguiculata* (L) Walp] is an important legume crop that provides food, feed and cash in the dry savanna areas of West Africa. It also enriches the soil through biological nitrogen fixation. Low availability of phosphorus (P) is a major constraint to cowpea production in the Sudano-Sahelian region of West Africa

(Danso, 1992; Mc Dermott, 1999). Legumes like alfalfa (Al-Niem et al., 1997; Deng et al., 1998), clover, common bean, cowpea (Cassman et al., 1981) and pigeon pea (Itoh, 1987) showed a high positive response to P supplementation. However, farmers' inability to purchase chemical fertilizer is another crucial problem especially in land locked country like Niger Republic where P fertilizer is scarce. There is, therefore,

need for screening cowpea for low P tolerance and response to added external P to obtain suitable genotypes for these predominantly low P soil environments. The identification/establishment of criteria useful for the selection of P use efficient cowpea genotypes would be needed for a successful selection and breeding program. The P use efficiency (grain yield per unit of nutrient supplied) (Moll et al., 1982) has been established to a certain extent (Sanginga et al., 2000; Bationo and Anand-Kumar, 2002). Root symbiosis with the AMF has also been shown to enhance P absorption by increasing the effective root area (Hayman and Mosse, 1971). A strong correlation between P use efficiency and root fungus AMF infection rate was observed in moist savanna of West Africa (Sanginga et al., 2000). Shoot-root ratio could also be an indicator of the response of cowpea lines to low P soils. Available evidence indicates that genes controlling tolerance to low P appear to be independently heritable and recombinable (Polle and Konzak, 1990). Thus any identified tolerant cowpea genotype can be crossed with another to transfer the tolerance trait. The objectives of this study were: 1) to identify cowpea genotypes that maintain high yields under low P conditions and respond to P application and 2) to identify criteria or mechanisms to explain the tolerance to low P and response to applied P.

Materials and methods

A total of 200 cowpea genotypes with diverse plant types, duration of growth, yield and origins were obtained from International Institute for Tropical Agriculture (IITA), Institute of Agricultural Research (IAR) Samaru, Zaria and National Institute for Agronomic Research of Niger Republic (INRAN). Field experiments were conducted at Minjibir (12° 8.73'N, 8° 39.97'E) on an Alfisol (Olsen P, 2.1 mg kg⁻¹), located in the Sudan savanna of Nigeria and at Toumnia, Zinder in Niger Republic (13° 28.76'N, 9° .79'E) located in the Sahelian zone on soils with an Olsen P level of 0.7 mg kg⁻¹. The mean rainfall in 2002 was 841.4 mm at Minjibir, and 372.8 mm at Toumnia. The field experiments were set up after P response curves in potted soils from the two locations had been determined and optimum P rates for the field experiments determined. The land was cleared of trees, ploughed and then disc harrowed. Cowpea genotypes were planted at an inter-row distance of 1 m and 0.25 m within row. Single super phosphate (SSP, 30 kg P ha⁻¹) and Rock

P from Niger (90 kg P ha⁻¹) were the sources of P applied by banding before planting. The Rock P has the following characteristics: 28% P₂O₅, 1.5% CS, 43.9% CaO, 2.1% Al₂O₃, 13% F₂O₃, 1.6% MgO, and 3.3% F (Bationo et al., 1986). Each genotype was grown in a single row of 4 m long with 42 plants in each row. The experimental design was a strip-plot design with 4 replications. The cowpea fields were sprayed with Delfos for aphids and Uppercolt for *Maruca* damages. Weeding was done according to standard agricultural practice. Plants were harvested at maturity and grain and fodder yields were measured.

In 2003 off-season, based on high biomass and grain yields, 15 genotypes selected from the 2002 field screening experiment were retested in a pot experiment in sand cultures at IITA Kano Station. The sand was air dried, sieved (< 2 mm screen) and weighed (3 kg sand pot⁻¹). A basal application of 60 mg K kg sand⁻¹, as muriate of potash, and 1 ml of micronutrient combination (Vincent, 1970) kg sand⁻¹ were applied to each pot at planting. Phosphorus was applied as SSP at the rate of 13 mg P kg sand⁻¹ or as RP at the rate of 39 mg P kg sand⁻¹. The seeds were surface sterilized with 95% ethanol for 1 min and 3% hydrogen peroxide for 5 min, and then rinsed with several changes of sterile water (Vincent, 1970). Five seeds of each line were sown in each pot and thinned to one plant pot⁻¹ a week after emergence. The experimental units were arranged as a strip plot in a randomized complete block design with three replications. All plants were harvested at 49 days after planting (DAP) and assessed for leaf area, shoot and root dry matter, shoot: root ratio, and nodulation.

In 2003 cropping season, the same 15 cowpea genotypes selected from the 2002 field screening experiments were planted on newly selected low available P fields at Toumnia and Minjibir with a total rainfall of 430.3 mm and 1031.4 mm, respectively. Cowpea genotypes were planted at a spacing of 25 cm within rows and 75 cm between rows at five seeds sown hill⁻¹ and the seedlings thinned to two, a week after emergence. Phosphorus was applied as SSP at 30 kg P ha⁻¹ and as RP at 90 kg P ha⁻¹ and each cowpea cultivar in a plot of 4 x 3 m received a basal application of 30 kg K ha⁻¹ as muriate of potash. No N fertilizer, mycorrhizal fungi or bradyrhizobia inocula were applied. The treatments of cowpea genotype as vertical factor and P source as horizontal factor were arranged in a strip plot design with 3 replications. Fresh roots were collected in sampling vials at early podding for AMF colonization rate by the method of Giovanetti and Mosse (1980). The

clearing and staining procedure described by Phillips and Hayman (1970) was used prior to detection of AMF colonization of cowpea roots.

Statistical analysis

Analysis of variance (ANOVA) was done using the SAS 8e program (SAS, 2001) to determine treatment and interaction effects. Least significant differences (LSD) were also calculated to assess treatment differences.

Results

The soils used in the experiments were sandy, slightly acidic at Minjibir and slightly alkaline at Toumnia and the organic carbon and total nitrogen as well as the available P were very low (Table 1).

A great deal of variability was observed among the cowpea genotypes in many traits. Some of the cowpea genotypes had narrow leaves (IT82E-16 and IT82E-32) while others had naturally broad leaves (DAN'ILA, TN256-87, IAR-48, IT98K-476-8, IT98D-1399). Achishiru, and IT98k-813-21 represented those with intermediate leaf size. Representatives of maturity groups of cowpea genotypes were as follows: Achishiru and IT93K-452-1, extra early maturing (60–65 days);

IT97K-819-170, IT97K-819-154, early maturing, (65–70 days); IT90K-277-2, TN256-87, IT98K-476-8, and IT98D-1399, medium maturing (70–80 days); and DAN'ILA and Borno, late maturing (over 80 days). Phosphorus application significantly ($P \leq 0.05$) increased the grain and fodder yield at both locations. The increase was in the order SSP > RP > control (without P). Five major P-response groups were identified at both Toumnia and Minjibir fields based on grain (Figure 1) and fodder (Figure 2) yields according to Gerloff (1977) as follows: 1) Inefficient nonresponder (low yield under low and high P conditions, 2) Inefficient responders (low yield at low P and high yield at high P), 3) Efficient nonresponders (high yield at low P and low yield at high P), and 4) Efficient responders (high yield at low and high P). 5) Genotypes that did not fall into any of these groups were classified as moderate or intermediate yielding lines. The genotypes TN256-87, IT98K-476-8 and IT98D-1399 were recorded as efficient at low P and but responded to P fertilizer application while IT97K-813-21 maintained high yields under low P (0P) conditions at the Minjibir location. This classification was however slightly different at Toumnia. At Toumnia, the genotypes IT97K-340-1, IT98D-1399, IT97K-819-170, and IT99K-826-119 were classified as inefficient responders; TN28-87 and TN256-87 as efficient responders; and IT97K-819-154 and IT99K-826-119 as efficient nonresponders.

The pot study revealed that all the 15 cowpea genotypes significantly ($P \leq 0.001$) responded to SSP addition to river sand and the differences were in the order SSP > RP > control (without P). Significant differences in shoot as well as root dry weight, were also observed between the cowpea lines and with the genotypes by P source interaction. The SSP application ($13 \text{ mg P kg sand}^{-1}$) significantly increased the shoot: root ratio of the cowpea lines ($P = 0.004$). The sister lines IT97K-819-170 and IT97K-819-154 had the highest shoot: root ratio of 11.7 and 9.9, respectively; and the genotype IT99K-826-119 had the lowest shoot: root ratio, with applied SSP (Table 2).

Significant ($P \leq 0.001$) differences in shoot: root ratio of cowpea genotypes was observed in the fields at both Toumnia and Minjibir. However, $P \times$ cowpea genotype interaction was not significant in these field trials. At Minjibir, the genotype TN256-87 had the highest shoot: root ratio (14) suggesting that the genotype had efficiently responded to SSP at Minjibir. The genotype IT98K-826-119 had the lowest shoot: root ratio (6) in the field at Minjibir while the genotype

Table 1. Physico-chemical properties of Minjibir(M), Toumnia(T) and River Sand(RS) 0-10 cm

Soil-sand Characteristics	M	T	RS
pH (H ₂ O)	6.5	7.3	6.3
pH (KCL)	5.4	6.5	5.8
Organic Carbon (g kg ⁻¹)	0.25	0.24	0.036
Total N (g kg ⁻¹)	0.013	0.01	ND
Olsen P (mg kg ⁻¹)	2.3	0.7	8
Bray I P (mg kg ⁻¹)	7.6	2.7	ND
NH ₄ -Acetate-extractable Cations (cmol kg ⁻¹)			
Ca	0.9	0.8	1
Mg	0.2	0.3	0.13
K	0.1	0.1	0.06
Na	0.4	0.4	0.23
Sand%	88	91	92
Silt%	5	2	2
Clay%	7	7	6
Textural class	Sandy	Sandy	NA

NA: not applicable; ND, not determined.

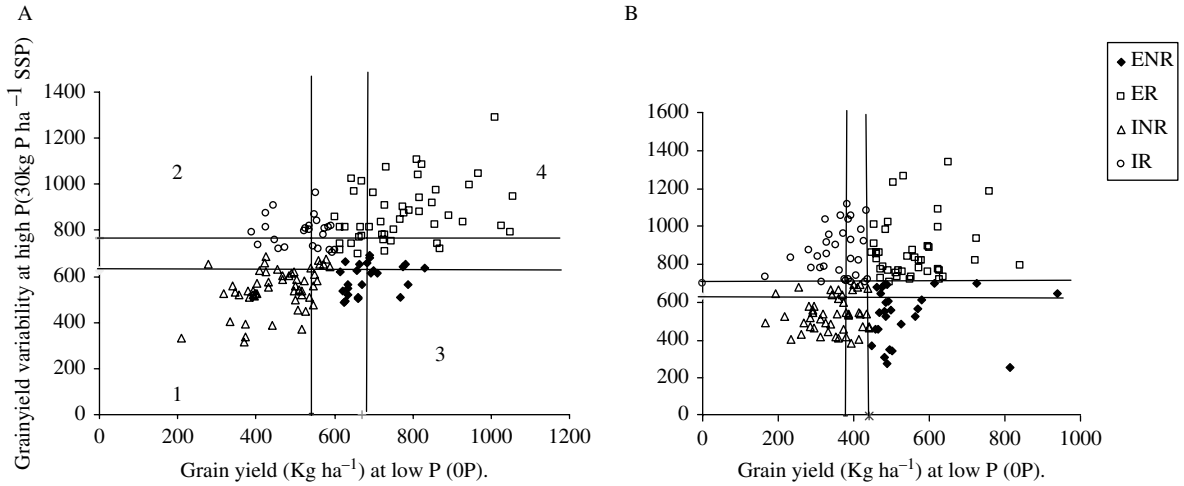

Figure 1a. Biplot of cowpea grain yield (kg ha^{-1}) at low P (OP) and high P (SSP): (A) at Minjibir field and (B) at Toumnia field in 2002 cropping season. The four lines at the middle represent the mean separation (LSD).

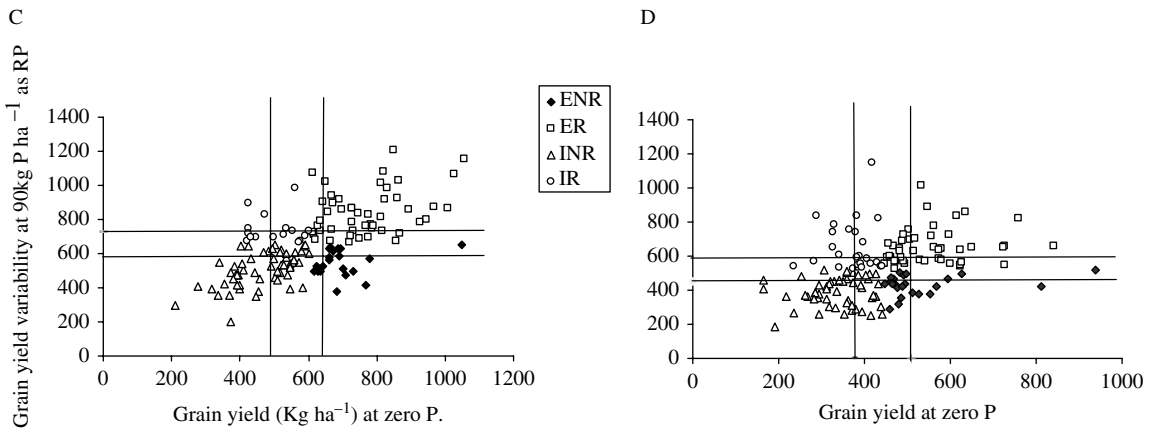

Figure 1b. Biplot of cowpea grain yield (kg ha^{-1}) at low P (OP) and high P (RP): (C) at Minjibir field and (D) at Toumnia field in 2002 cropping season. The four lines at the middle represent the mean separation (LSD).

IT00K-1148 had the same shoot: root ratio under both low and high P conditions. On the other hand, the same genotype (IT00K-1148) had high shoot: root ratio under high P condition at Toumnia. There were high shoot: root ratios from Aloka (24), IT97K-819-170, (19) and IT97K-813-21 (15) at Toumnia under rock P condition suggesting that the genotypes could probably use RP from Niger efficiently. Also, the cowpea genotypes IT98K-476-8 and IT98D-1399 gave relatively high shoot: root ratios under low P conditions at both locations. The cowpea genotypes TN256-87, IT98K-813-21, IT98D-1399, and DAN'ILA had shoot: root ratios of 14, 13, and 12, respectively when no P was applied. This suggests that these genotypes

are efficient in P exploration to obtain P from the P-deficient soil hence the increase in shoot: root ratio (Table 2). For the root to effectively take up phosphorus in low P soil, plant root-microbe interaction such as AMF association could be significant and may be responsible for the improved nutrient uptake and shoot growth. Phosphorus application suppressed AMF colonization in more than 53% of field grown-cowpea genotypes at both Minjibir and Toumnia (Table 3). The assessment of cowpea genotypes in terms of AMF infection rate in relation to P availability was significant ($P = 0.05$) at Toumnia and highly significant ($P < 0.001$) at Minjibir. The cowpea genotype IT97K-813-21 had the highest (24%) AMF infection rate under low

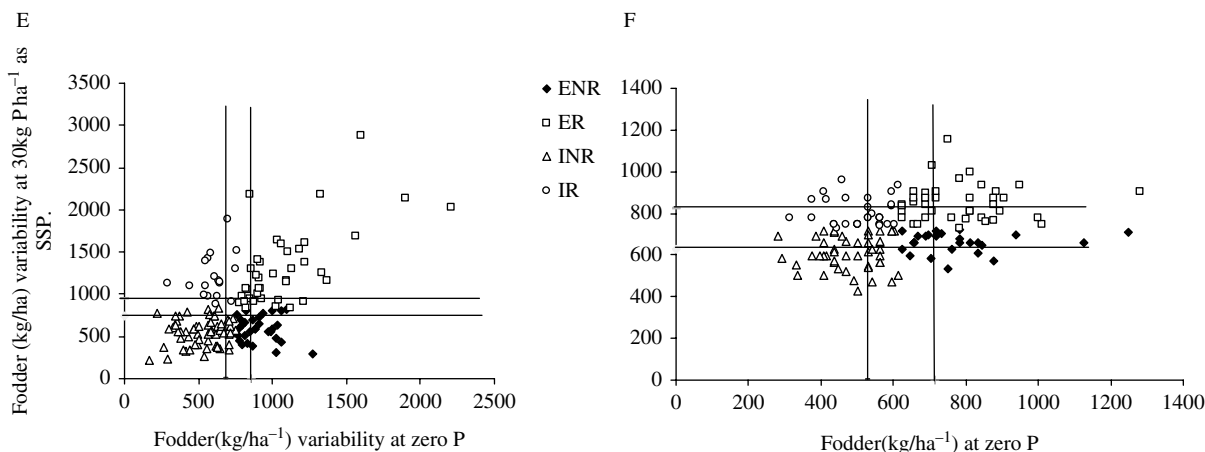

Figure 2a. Biplot of cowpeas fodder yield (kg ha^{-1}) at low P (OP) and high P (SSP): (E) at Minjibir field and (F) at Toumnia field in 2002 cropping season. The four lines at the middle represent the mean separation (Lsd).

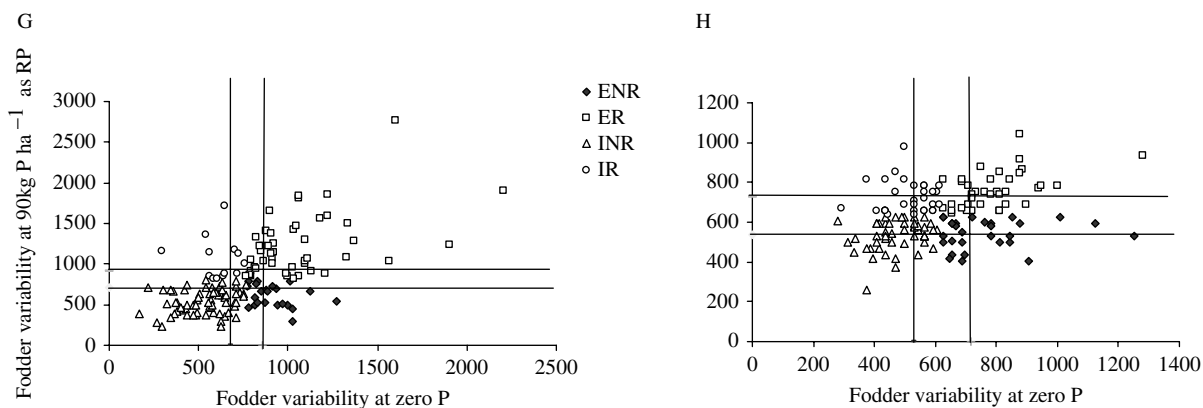

Figure 2b. Biplot of cowpeas fodder yield (kg ha^{-1}) at low P (OP) and high P (RP): (G) at Minjibir field and (H) at Toumnia field in 2002 cropping season. The four lines at the middle represent the mean separation (Lsd).

P and IT97K-819-170 had the lowest (6%) at Toumnia while IT98K-476-8 had the highest (21%) and Aloka, the lowest (4%) under low P conditions at Minjibir. The cowpea line IT97K-340-1 had the highest infection rate (29%) under RP followed by IT99K-826-119 (28%) and IT98D-1399 (23%) at Toumnia. At Minjibir, the genotypes IT98K-476-8 with 21% infection rate and IT98D-1399 with 20% infection rate under RP condition, were the highest suggesting that the genotypes were associated with AMF at the various locations for enhanced RP utilization. DAN'ILA was observed to be associated to AMF (13%) under RP at Minjibir, where it originated from while Aloka was found to be better associated to AMF (15%) at Toumnia, the genotype's origin. This suggests the location specificity due probably to cowpea genotypes adaptability to association

with indigenous AMF. The relative P use efficiency (RPUE) of the cowpea genotypes also varied significantly at both Minjibir and Toumnia. The local variety DAN'ILA was observed to have the highest RPUE of $38 \text{ kg grain (kg P)}^{-1}$ at Minjibir and the genotype IT98D-1399 was recorded as the most efficient P user ($13 \text{ kg grain (kg P)}^{-1}$ at Toumnia (Table 4).

Discussion

The data indicate that significant genotypic differences exist in P use efficiency in cowpea but this is influenced by the environment as demonstrated by Bationo and Anan Kumar (2002). The study established the criteria for selection of cowpea genotypes in relation to

Table 2. Variability in shoot: root ratio of cowpea genotypes grown in P-deficient soils at Toumnia and Minjibir

Genotype(G)	TRTS(T)							
	C	RP	SSP Minjibir	Class ¹	C	RP	SSP Toumnia	Class ¹
IT90K-277-2	6	7	8	INR	8	5	8	IR
IT97K-340-1	NG	NG	NG		12	8	14	IR
IT97K-813-21	13	8	11	T	11	15	11	ER
IT97K-819-154	8	9	10	INR	22	13	17	IR
IT97K-819-170	10	10	12	INR	16	19	10	IR
IT98D-1399	13	8	11	ER	12	11	7	IR
IT98K-476-8	10	9	8	ER	9	8	8	ER
IT99K-826-119	6	7	6	INR	10	11	8	T
ALOKA	9	12	11	INR	19	24	10	ER
DAN'ILA	12	12	11	IR	13	13	11	INR
IAR-48	5	4	6	IR	8	13	11	ER
IT00K-1148	12	12	12	INR	12	13	13	ER
TN256-87	14	14	14	ER	16	14	15	ER
TN28-87	12	14	11	T	13	10	9	ER
MEANS	10	10	11		13	13	11	
Cv%	33				30			
	T	G	T×G		T	G	T×G	
LSD ($P \leq 0.05$)	3	3	5		4	6	10	
Significance	NS	**	NS		NS	**	NS	

¹IR, Inefficient Responder; INR, Inefficient non responder; ER; Efficient responder; and T, Tolerant; NS, not significant; **, highly significant. NG, No germination; Class; P use efficiency group.

P availability. The high grain and fodder yields of the cowpea genotypes in relation to P availability was one of the major criteria used to select the cowpea genotypes. Another criterion was the shoot: root ratio in relation to P availability where the P deficient cowpea genotypes gave low shoot: root ratio and the P efficient and P responder gave high shoot: root ratio. Association of the cowpea genotypes root with AMF in relation to P availability was also examined as a potential criterion. The cowpea genotypes that gave high yields of grain, fodder or both under low P conditions were considered as efficient. While those that gave high yields only under high P conditions were classified as responding to P. Genotypes, which gave high yields under both low and high P conditions were considered as efficient and with good response to applied P.

Differences in P use efficiency among the cowpea genotypes were observed in the field screening experiment and different P response groups were established depending on location and whether grain yield or stover yields were used as basis of the evaluation. The study supported earlier observations made by Bationo

and Anan Kumar (2002), and Sanginga et al. (2000) that environmental factors affect response of cowpea genotypes to P levels. However, some genotypes (e.g., IT98K-476-8, IT97K-826-119, and IT97K-813-21) were consistent in their performance at the two locations. On the other hand, a local variety DAN'ILA previously described as efficient in utilizing inherent soil P because of its long lateral roots for P exploration in the soil (Singh et al., 1997) and as non-responder to applied P in previous work in moist Savanna (Sanginga et al., 2000), appeared to dependent on external application of P for optimum growth. Our data indicated that the P requirement for cowpea varies widely within the germplasm. The response of the sister genotypes IT97K-819-154 and IT97K-819-170, suggests the expression of the same gene expression within the cowpea genotypes (Polle and Konzak, 1990).

The increase in shoot: root ratio upon P application supported observations made by Anghinoni and Barber (1980) on the effect of P application on shoot: root ratio that the crops use the applied P to develop

Table 3. Variability in AMF infection rates of selected genotypes in P-deficient soils at Toumnia and Minjibir

Genotype(G)	Toumnia			Minjibir		
	C	RP	SSP	C	RP	SSP
	AMFIR (%)					
IT90K-277-2	15	11	8	19	12	5
IT97K-340-1	8	29	9	NG	NG	
IT97K-813-21	24	16	10	17	13	3
IT97K-819-154	17	11	7	2	1	2
IT97K-819-170	6	7	10	7	1	3
IT98D-1399	14	23	9	20	10	6
IT98K-476-8	13	11	9	21	20	6
IT99K-826-119	21	28	12	8	5	8
ALOKA	16	15	11	4	8	3
DAN'ILA	11	15	4	11	13	3
IAR-48	20	13	12	14	8	5
IT00K-1148	19	10	6	16	12	6
TN256-87	19	15	12	15	8	6
TN28-87	15	6	10	8	7	5
Means	16	15	9	12	9	5
CV (%)	47		46			
	T	G	T×G	T	V	T×G
LSD	4	6	10	3	4	7
Significance	*	**	*	**	***	**

* significant, ** highly significant***, very highly significant NG, No germination.

the above ground biomass. The increase in the shoot: root ratio in some genotypes has been explained as a mechanism (root interception) used by some crops to efficiently use P added to soils for dry matter production. The genotype IT99K-826-119, which had lowest shoot: root ratio (under low P conditions), suggests that the line performed well under low P conditions in terms of below ground biomass production. This would probably be significant in the next cropping system. The reduction in AMF colonization rate in the fields (Toumnia and Minjibir) indicate the role that AM fungus may play in absence of the fertilizer P in these dry areas of West Africa (Bagayoko et al., 2000). The increase in AMF infection with some cowpea lines under RP conditions confirmed the results by other workers (Vanlauwe et al., 2000; Manjunath et al., 1989). This may be probably related to the low reactivity of the RP phosphate from Niger due to its low molar ratio of the carbonate to phosphate (Mahamane et al., 1997). The relative P use efficiency increased from 0 to 38 kg grain (kg P⁻¹) for the local variety DAN'ILA and this suggests that the variety is an inefficient (inefficient at low P levels) but responds to external application of SSP. However, certain improved varieties (e.g., IT97K-813-21, IT97K-826-119) have shown that they are non-responsive to P application by giving almost

Table 4. Relative phosphorus use efficiency (kg grain (kg P)⁻¹) of cowpea genotypes grown at Toumnia and Minjibir

Genotype(G)	RPUE (kg grain (kg P) ⁻¹)						
	Toumnia			Minjibir			
	RP	SSP	Class ¹	RP	SSP	Class ¹	
IT90K-277-2	1.17	8.44	IR	0.10	2.00	INR	
IT97K-340-1	3.52	8.2	ER	NG	NG		
IT97K-813-21	3.17	0.00	ER	3.50	18.70	T	
IT97K-819-154	1.04	7.26	IR	0.60	2.80	INR	
IT97K-819-170	2.32	2.53	IR	-2.60	7.60	INR	
IT98D-1399	7.92	13.13	T	-4.60	21.50	IR	
IT98K-476-8	-5.62	-1.00	ER	7.10	0.30	ER	
IT99K-826-119	NG	NG		-2.50	-2.50	INR	
ALOKA	1.31	4.69	ER	2.10	3.20	INR	
DAN'ILA	1.15	0.75	INR	2.40	38.10	IR	
IAR-48	0.00	9.93	ER	9.70	30.00	IR	
IT00K-1148	-11.55	1.00	ER	6.40	14.20	INR	
TN256-87	2.82	0.00	ER	-0.70	3.20	ER	
TN28-87	-3.23	3.61	ER	-1.70	1.10	T	
MEANS	0	5		2	11		
	P source (P)	Genotype (G)	P×G	P source (P)	Genotype (G)	P×G	
LSD	6.159	5.278	9.895	13	16	29	

NG, No germination.

the same RPUE values with and without SSP. The PUE results demonstrate that this trait is also a useful criterion for the selection of P use efficient genotypes for specific sites.

Conclusion

Wide differences were observed between cowpea genotypes in grain and fodder yields, phosphorus use efficiency, AMF colonization rate and shoot: root ratio parameters. The cowpea genotypes also differed widely in their P requirement for growth and AMF colonization rate in the fields. The results indicated that cowpea genotypes IT97K-476-8, IT98D-1399, and 97K-813-21 with high RPUE and high shoot: root ratio under low P conditions will be suitable for cropping systems of dry savannas. The results also indicated that the cowpea genotypes IAR-48, and TN256-87 are tolerant to low P soils.

The potential to use low reactive rock P in combination with selected improved P-efficient genotypes has been demonstrated in this study. The cowpea genotype 97K-340-1, which exhibited some response to RP application, needs further testing to confirm this attribute. The results also suggest that AMF may play a crucial role in these soils and the need for Breeders to consider it in their cowpea breeding programmes. The results also, affirm the importance of considering P requirements of these cowpea lines when introducing them in Sudan and Sahel savanna zones.

Acknowledgments

This work was carried out under the Fellowship of the International Institute for Tropical Agriculture (IITA) and additional support from ACIAR, Australia.

References

- Al-Niem T.S., Kahn M.L., and Mc Dermott T.R. 1997. Phosphorus metabolism in the *Rhizobium tropici*-bean symbiosis. *Plant physiology*. 113: 1233–1242.
- Anghinoni I and Barber S.A. 1980. Effect of phosphorus nutrition on shoot to root ratio *Agron. Journal* 72: 685–688.
- Bagayoko M, Buerkert A., Lung G., Bationo A. and Romheld V. 2000. Cereal/legume rotation effects on cereal growth in Sudano-Sahelian West Africa: Soil mineral nitrogen, mycorrhiza and nematodes. *Plant and Soil* 218: 103–116.
- Bationo A. and Anand-Kumar K. 2002. Phosphorus use efficiency as related to sources of P-fertilizers, rainfall, soil, crop management and genotypes in the West African Semi Arid Tropics. In: J.J Adu-Gyamfi (Ed). *Food security in nutrient stressed environment: exploiting plant's genetic capabilities*. pp. 145–154.
- Bationo A. Mughogho S.K. and Mokwunye A.U. 1986. Agronomic evaluation of phosphate in tropical Africa. In: Africa Mokwunye, A.U. and Vlek, P.G., (Eds) *Management of Nitrogen and Phosphorus Fertilizers in Sub-Saharan*. Development in Plants and Soil Sciences. Vol. 24. Dordrecht, the Netherlands: Martins Nijhoff. pp 283–318.
- Cassman K.G., Whiteny A.S. and Fox K.L. 1981. Phosphorus requirement of soybean and cowpea as affected by mode of N nutrition. *Agron. J.* 73:17–22.
- Danso S.K.A. 1992. Biological nitrogen fixation (BNF) in tropical agro systems. Twenty years of Biological nitrogen fixation research in Africa. In: Mulongoy K., Gueye M. and Spencer D.S.C. (Eds), *BNF and Sustainability of Tropical Agriculture*. John Wiley and sons Ltd. Chimester, UK, pp.3–13.
- Deng S., Kahn M.L., and Mc Dermott T.R. 1998. Characterization and mutagenesis of a non specific acid phosphatase cloned from *Rhizobium meliloti*. *Arch. Microbiol.* 170:18–26.
- Gerloff, G.C. 1977. Plant efficiencies in the use of nitrogen, phosphorus, and potassium. In: Wright M.J. (Ed) *Plant Adaptation to Mineral Stress in Problem Soils*. New York, Cornell University Press. pp. 161–174.
- Giovanetti M. and Mosse B. 1980. An evaluation of techniques for measuring Vesicular-arbuscular mycorrhizal infection in roots. *New Phytol.* 84: 489–500.
- Hayman D.S. and Mosse B. 1971. Plant growth response to vesicular arbuscular mycorrhiza I. Growth of endogone inoculated plants in phosphate deficient soils *New Phytol.* 70: 19–27.
- Itoh H.S. 1987. Characteristics of phosphorus uptake of chickpea in comparison with pigeon pea, soybean and maize. *Soil Sci, Plant Nutr.* 33: 417–422.
- Mahamane I., Bationo A, Seyni F. and Hamidou Z. 1997. Acquis recents des recherches sur les phosphates naturels du Niger. In: Renard G. Neef A., Becker K. and Von Oppen M. (eds). *Soil Fertility Management in West African Land Use Systems*. Margraf Verlag, Weiker-sheim, Germany, pp. 73–78.
- Manjunath A., Hue N.V. and Habte M. 1989. Response of *Leucaena leucocephala* to vesicular arbuscular mycorrhizal colonization and rock phosphate fertilization in an oxisol. *Plant and soil*, 114: 127–133.
- Mc Dermott T.R. 1999. Phosphorus assimilation and regulation in Rhizobia. In: E.W Triplett (Ed), *Nitrogen fixation in prokaryotes: Molecular and cellular biology*. Horizon Scientific Press USA.
- Moll R.H., Kamprah E.J. and Jackson W.A. 1982. Analysis and interpretation of factors which contribute to efficiency of nitrogen utilization. *Agro. J.* 74: 462–564.
- Phillips J.M. and Hayman D.S. 1970. Improved procedure for clearing roots and staining parasitic and Vesicular arbuscular mycorrhizal fungi for rapid assessment of infection. *Trans. Brit. Myc. Soc.* 55: 158–161.
- Polle E.A. and Konzack C.F. 1990. Genetics and breeding of cereals for acid soils and nutrient efficiency. In: Baligar V.C., and Dunea R.R. (Eds), *Crops are Enhancers of nutrient use*. Academic Press. pp. 81–121.

- Sanginga N., Lyasse O. and Singh B.B. 2000. Phosphorus use efficiency and nitrogen balance of cowpea breeding lines in a low P soil of the derived savanna zone in West Africa. *Plant and Soil*. 220: 119–128.
- Singh B.B., Chambliss O.L and Sharma B. 1997. Recent advances in cowpea breeding. In: *Advances in Cowpea Research*. Singh B.B., Mohan D.R., Dashiell K.E and Jackai L.E.N. (Eds). IITA. Ibadan, Nigeria, pp: 30–49.
- SAS 2001. SAS Institute Inc. Cary, North Carolina, USA.
- Vanlauwe B., Nwoke C., Diels J, Sanginga N., Carsky R.J., Deckers J. and Merckx R. 2000. Utilisation of rock phosphate by crops on a representative toposequence in the Northern guinea savanna zone of Nigeria: response by *Mucuna pruriens*, *Lablab purpureus* and maize.
- Vincent J.M. 1970. A manual for practical study of the root nodule bacteria. Blackwell Scientific Publications, Oxford.

The potential benefits of *Azolla*, Velvet bean (*Mucuna pruriens* var. *utilis*) and N fertilizers in rice production under contrasting systems in eastern Uganda

Crammer K. Kaizzi^{1*}, Henry Ssali¹, Angella Nansamba¹, and Paul, L.G. Vlek²

¹Kawanda Agricultural Research Institute (KARI), National Agricultural Research Organization (NARO) Box 7065 Kampala, Uganda, Tel. 256 41 567 696, Fax. 256 41 567 649, email: landuse@infocom.co.ug; ²Center for Development Research (ZEF), University of Bonn, Walter-Flex Str. 3. D-53113 Bonn, Germany, Tel. 49 228 73 18 66, Fax 49 228 73 18 89; *Corresponding author: E-mail: kckaizzi@hotmail.com

Abstract

Nitrogen is the most limiting nutrient in farming systems of Uganda. Research was conducted in E. Uganda at two sites (Doho and Nakisenye) with contrasting rice production systems to evaluate the benefits of either a mucuna – green manure, or an *Azolla* – green manure as well as inorganic fertilizers in rice production. Farmers in the Doho grow two rice crops in a year due to irrigation facilities. In contrast, Nakisenye farmers grow one rice crop during the long rains only. As green manure benefits are derived in the subsequent season, this study evaluated the benefits of the alternative systems over a two-season cycle. There was a significant ($P < 0.05$) increase of 0.8 t ha^{-1} grain in response to a preceding mucuna crop and to the application of inorganic N at Nakisenye. The use of *Azolla* or the application of inorganic N was equally effective resulting in an average increase of 1.4 t ha^{-1} of grain, application of P and K fertilizers resulted in, an additional 0.9 t ha^{-1} of grain. The use of inorganic N fertilizers, mucuna and *Azolla* is economic viable in the rice farming systems and farmers will not lose money by adopting these interventions. Farmers appreciated the value of the alternative strategies for increasing crop yield plus other benefits. Variation in farmers' assessment of the green manure emphasizes the need to provide multi-purpose ones, which can be tailored to prevailing conditions.

Key words: Nitrogen, *Azolla*, mucuna, inorganic fertilizers, economic benefits

Introduction

A Crop yield per unit area of production in sub-Saharan Africa (SSA) is declining (Sanchez et al., 1996). The main contributing biophysical factors are low inherent soil fertility particularly N and P deficiencies (Bekunda et al., 1997), exacerbated by nutrient/soil fertility depletion (Vlek, 1993; Sanchez et al., 1997). Loss of nutrients in crop harvests as well as through runoff and soil erosion is on the increase in many farming systems. Yet, many farmers are unable to compensate for these losses, resulting in the negative nutrient balances at the national level for sub-Saharan Africa countries

(Stoorvogel and Smaling, 1990) and at the regional scale for the farming systems of Eastern and Central Uganda (Wortmann and Kaizzi, 1998).

Replenishing and enhancing soil N, P and K is essential for improved and sustainable productivity. Inorganic fertilizers are the only option available to improve and balance the loss of P and K. However, N has an additional source through biological nitrogen fixation (BNF). Unfortunately socio-economic factors do not favor the use of inorganic fertilizers by the smallholder farmers, for instance they cost 2–6 times as much as in Europe mainly due to transport and other charges (Sanchez, 2002). Therefore BNF can be exploited for

increased productivity through the use of legumes, and the aquatic fern *Azolla* in the farming systems. Under favorable conditions that is, a good supply of nutrients, moisture availability and optimum pH (Peoples et al., 1995), herbaceous legumes can accumulate 100 to 200 kg N ha⁻¹ in 100–150 days in the tropics with a significant portion derived from BNF (Giller et al., 1994). *Azolla* can accumulate 40–90 kg N ha⁻¹ in 30–45 days (Watanabe, 1982) with more than 80% derived from BNF (Kikuchi et al., 1984; Watanabe et al., 1991). Biological nitrogen fixation can meet N requirements and sustain tropical agriculture (Giller et al., 1994; 1997).

The use of legumes and *Azolla* for soil fertility improvement as green manure has declined in many countries where N fertilizers are readily available (Giller and Cadisch, 1995). However, green manures have a potential in the agricultural systems of the smallholder farmers in SSA, because of the low or non-use of external inputs. Even economic considerations make BNF an attractive N source for resource-poor farmers (Giller and Wilson, 1991) and a solution for the low-input agriculture typical in SSA (Van Cleemput, 1995). *Azolla* is abundant in eastern Uganda, where farmers consider it an obnoxious weed, removing it from the field, which is a waste of a potential source of N in the low-input systems.

In this study the use of inorganic N fertilizers was compared with the exploitation of BNF through the use *Azolla* – green manure, and Velvet bean (*Mucuna pruriens*), either as relay crops, or as an improved fallow. The objectives of the study were to determine under contrasting production systems: (i) rice yield in response to *Azolla*, mucuna or inorganic N fertilizers, (ii) the economic benefits of using *Azolla*, mucuna and inorganic N fertilizers and (iii) farmers assessment of the alternative strategies.

Materials and methods

Site description

On-farm (researcher designed but farmer managed trials) research was conducted at Nakisenye (1°N, 34°E, 1138 masl) and Doho rice scheme [Doho] (1°N, 34°02'E, 1083 masl), in eastern Uganda. Both sites receive 1164 mm of rainfall per year. Farmers at Doho grow two rice crops in a year due to irrigation facilities, compared to their counterparts at Nakisenye growing one rice crop during the long rains, and either planting

upland crops or leave their land under fallow during the short rains due to insufficient water for rice cultivation.

The trials were set up on 20 randomly selected farmers' fields at each site and managed by farmers, with each farm acting as a replicate. The farmers' fields were characterized through analysis of composite soil samples collected from the 0–20 cm depth prior to the initiation of the trials. Soil samples were air-dried and ground to pass a 2 mm sieve and analyzed for pH, soil organic matter, extractable P, Ca, K and texture according to Foster (1971).

Nakisenye

The 2000b season (August–December) was mainly for testing various alternatives to the common practice of either planting upland crops or leaving the land under fallow. In the 2001a season (March–July), the impact of the treatments of the preceding season was evaluated for their effect on rice. During the 2001a season (March–July) the treatments in the square brackets [] were superimposed on those with the equivalent number of the previous season. The treatments were; (1) Maize – control/farmers practice (2) Maize [received 60 kg N ha⁻¹ in 2001a season] (3) Maize [received (60 kg N + 20 kg P + 25 kg K) ha⁻¹ in 2001a season] (4) Mucuna relay (5) Mucuna relay + 25 kg P ha⁻¹ [received (20 kg P + 25 kg K) ha⁻¹ in 2001a season] (6) Mucuna fallow (7) weedy fallow. Rice was planted on all plots during 2001a season.

The plot size was 10 m by 10 m and field preparation was done by hand. Mucuna was partially incorporated into the soil during the time of seedbed preparation. Rice variety “China K87” was direct seeded by broadcasting the seeds, a common practice in the area. Phosphorus fertilizer (20 kg P ha⁻¹) was broadcast on treatment 3 and 5 at the time of planting. Nitrogen (60 kg N ha⁻¹) and K (25 kg K ha⁻¹) fertilizers were applied in three splits, with the first split (equivalent to 25%) three weeks after germination, second split (equivalent to 50%) at tillering, and the third split (equivalent to 25%) at panicle initiation. Water was drained off all plots/fields three days before and allowed onto the fields two days after fertilizer application. The N and K fertilizers were also broadcasted within the rows, and covered immediately with some soil.

The rice yield (grain and straw) was determined at maturity using a 1 m by 1 m quadrant randomly placed four times within the plots. Both grain and straw samples were collected for moisture determination. The

rice yield was adjusted to 14% moisture content. No analysis for nutrients was carried out.

Doho

The plot size was 3 m by 17 m. The plots were separated by raised bunds to control undesired lateral movement and/or spillover of water, Azolla and fertilizers between treatments. The treatments during the two seasons were, (i) rice – control (farmer practice), (ii) rice + [60kg N + 20 kg P + 25 kg K] ha⁻¹, (iii) rice + Azolla, (iv) rice + [60kg N + 20 kg P + 25 kg K] ha⁻¹ + Azolla, (v) rice + 60 kg N ha⁻¹. Twenty five (25) day old rice seedlings of variety “China K87” raised in a nursery-bed were transplanted at a spacing of 20 by 20 cm. Two seedlings were transplanted per hill.

Fertilizers were applied during the two seasons at rates and the time of application similar to those at Nakisenye.

Application of Azolla

During the 2000b season, Azolla was collected from fields where it was abundant and broadcast as uniformly as possible in plots designated for treatment (iii) and (iv) at average rate of 1.4 t ha⁻¹ (dry weight), manually incorporated and trampled into the soil at transplanting. The average biomass was determined from six randomly selected fields, using a 1 m by 1 m quadrant. The Azolla in the quadrant was washed, and thoroughly drained before weighing, sub-samples were collected for moisture and total N determination. The samples were oven dried at 60°C to a constant weight, ground and analysed for total N. Total N was determined according to Anderson and Ingram (1993). The unincorporated Azolla was allowed to re-grow, and incorporated at tillering stage. The process was repeated at panicle initiation stage. Weeds were manually trampled into the soil. Beta-cyfluthrin 0.05–2.5% (Ambush) was used to control stem borers.

The same procedures were repeated during 2001a season, but by this time all target plots {i.e. treatments (iii) and (iv)} had Azolla arising from that added during the previous season. The yield (grain and straw) was determined at maturity using a 1 m by 1 m quadrant placed eight times randomly within the plots. Samples were collected for moisture determination.

The rice grain yield was adjusted to 14% moisture content.

Statistical analysis

Data was subjected to analysis of variance (ANOVA) using a general linear model and comparisons of treatments were made by the least significant difference (LSD) using Statistix V. 2.0 (Statistix for windows, Analytical Software, 1998).

Economic analysis

The partial budgets for the different strategies were determined according to CIMMYT (1988) methodology. The economic benefits of the treatments were determined for the combined 2000b and 2001a seasons, which is equivalent to one year because the benefits of green manure are derived in the subsequent season.

The items used to calculate the benefit to cost ratio that is, [(benefit/cost) = gross benefits/total variable costs] for the different systems included;

1. Total variable costs = {the cost of maize, rice and mucuna seeds, pesticides, mucuna seeds, farm gate price of urea, muriate of Potash and TSP fertilizers, labor for -ploughing, -weeding, -making ridges, -guarding rice fields -fertilizer application, -harvesting, -removing mucuna vines from maize plants, transport cost to the mill, and milling charges};
2. Gross benefits = adjusted maize/and rice yield (90% of the average yield i.e. to cater for the relatively higher yield obtained on smaller plots due to better management) multiplied by field price of maize/and rice.

The benefit to cost ratio (B/C) is the indicator of the profitability of a given strategy, and value of one (1) is the break-even point implying that farmers recover the total variable costs. The B/C > 1 implies that farmers have earned some profits, and B/C < 1 indicate that farmers incurred losses.

Farmer evaluation of green manure and inorganic fertilizers

Data on farmers' independent assessment of the alternative strategies was collected through individual

interviews with all farmers who participated in the study using an open-ended questionnaire. Individual interviews were preferred to group interviews to avoid biased responses due to influence by vocal members.

Results

Soil characteristics

The results of the analysis for selected soil properties are given in Table 1. The fields had clay soils, and are acidic.

Maize, mucuna and rice yield

There was no significant difference ($P < 0.05$) in maize grain yield between the mucuna-maize intercrop (3.4 t ha⁻¹) and the control – sole maize (3.1 t ha⁻¹),

implying that, mucuna did not affect the maize. The rice yield (t ha⁻¹) in response to the different treatments at Nakisenye during 2001a season is shown in Table 2.

Doho Azolla biomass and N accumulation

The estimated amount (dry weight) of Azolla incorporated at the beginning of 2000b and 2001a season activities was 1.47 and 1.27 t ha⁻¹, respectively, with an average total N content of 2.9%. It is estimated that 3.8 and 4.4 t ha⁻¹ of Azolla was incorporated into the soil during 2002b and 2001a season, respectively from the three crops of Azolla, contributing 110–128 kg N ha⁻¹. This is on the assumption that the total N content of Azolla did not vary, and same quantities of Azolla were incorporated each time. The quantity of N accumulated by Azolla is within the range reported by Kikuchi et al. (1984);

Table 1. The range and mean values of selected soil properties at Nakisenye and Doho

Soil parameter	Location				
	Critical value ¹	Nakisenye		Doho Rice Scheme	
		Range	Mean	Range	Mean
pH (1 soil:2.5 water)	5.2	4.7–5.8	5.1	4.6–5.2	4.8
OM (%)	3.0	5.0–15	12.6	5.1–18.2	11.6
Extractable P (mg kg ⁻¹)	5.0	29–52	45.1	8.4–63.7	26.9
Extractable K (cmolc kg ⁻¹)	0.4	0.7–1.6	1.1	0.6–1.4	0.9
Extractable Ca (cmolc kg ⁻¹)	0.9	2.2–5.0	4.0	4.6–7.0	5.9
Sand (%)	na	23–40	29	26–40	32
Silt (%)	na	19–35	23	7–33	23
Clay (%)	na	24–50	48	23–53	45

¹Below these values, levels are low/deficient (Foster, 1971); na = not applicable Nakisenye.

Table 2. Rice yield (t ha⁻¹) at Nakisenye during 2001a season (No. of farmers = 13)

Treatment	Grain	Straw
Control	1.5	10.8
60 kg N ha ⁻¹	2.0	11.7
NPK ^a	2.3	15.5
Preceding mucuna relay	2.3	13.7
Preceding mucuna relay + PK ^b	2.1	16.9
Preceding mucuna fallow	2.2	15.4
Preceding a weedy fallow	1.7	14.9
Mean	2.0	14.1
LSD _{5%}	0.4	5.1

^a NPK = (60 kg N + 20 kg P + 25 kg K) ha⁻¹, ^b PK = (20 kg P + 25 kg K) ha⁻¹.

80% of which is presumably derived from biological N fixation (Eskew, 1987; Watanabe, 1982; Watanabe et al., 1991).

Rice yield

The rice yield response to the different treatments at Doho is presented in Table 3. There was a significant increase ($P < 0.05$) in rice yield in response to the different amendments compared to the control, indicating the effectiveness of the different strategies to increase rice production.

Economic analysis

Nakisenye

The economic analysis at Nakisenye included a short rains (2000b season) maize crop and long rains (2001a season) rice crop. The partial budget over of the system over one year is given in Table 4.

Doho

The results of the economic analysis showed that farmers' break-even with their current practice of growing rice each season without applying any source of nutrients (Table 5). It is observed that inorganic fertilizers or Azolla are more profitable than the current farmers' practice, due to the significant increase in rice grain yield from the use of these strategies.

Farmers' evaluation of green manure and inorganic fertilizers

Nakisenye

Mucuna

The results of the farmers' assessment of mucuna and inorganic fertiliser use in the maize and rice systems at Nakisenye are presented in Table 6. In general, a large number of farmers appreciated the value of mucuna and inorganic fertilisers in improving soil productivity and increasing crop yields.

Table 3. Rice yield ($t\ ha^{-1}$) at Doho during 2000b and 2001a seasons (No of farmers = 14)

Treatment	Season			Season		
	2000b	2001a Grain	Total	2000b	2001a Straw	Total
Farmer practice (control)	2.2	1.5	3.7	6.7	7.0	13.7
NPK ¹	3.4	2.8	6.2	10.3	9.6	19.9
Azolla	2.7	2.2	4.9	8.1	6.4	14.5
Azolla + NPK ^a	3.0	2.5	5.5	9.5	7.8	17.3
60 kg N ha^{-1}	2.9	2.4	5.3	8.7	8.4	17.1
Mean	2.9	2.3	5.2	9.2	7.8	16.5
LSD _{5%}	0.4	0.4	0.7	2.3	2.3	3.3

^a NPK = (60 kg N + 20 kg P + 25 kg K) ha^{-1} .

Table 4. The partial budget at Nakisenye (short rains – maize, long rains – rice)

Treatment	Gross benefits ^a	Total variable costs	Benefit to cost ratio ^b
	,000 Uganda shillings ^c ha^{-1}		
Farmer practice (maize – rice)	936	591	1.58
60 kg N ha^{-1}	1233	757	1.63
NPK ^d	1328	893	1.49
Mucuna relay + PK ^e	1266	911	1.39
Mucuna relay	1340	628	2.13
Mucuna fallow	977	561	1.74
Weedy fallow	783	476	1.65

^a Gross benefits = yield * price; ^b Benefit to cost ratio = (Gross benefits/total variable costs); ^c conversion rate of 1750 Uganda shillings per US dollar; ^d NPK = (60 kg N + 20 kg P + 25 kg K) ha^{-1} ; ^e PK = (25 kg P + 25 kg K) ha^{-1} .

Table 5. Partial budget for rice production at Doho

Treatment	Gross benefits ^a	Total variable costs	Benefit to cost ratio ^b
	,000 Uganda shilling ^c ha ⁻¹		
Farmer practice (rice – rice)	1539	1314	1.27
60 kg N/ha	2385	1697	1.41
NPK ^d	2790	1999	1.40
Azolla + NPK ^d	2475	1935	1.28
Azolla	2205	1492	1.48

^a Gross benefits = yield * price; ^b Benefit to cost ratio = (Gross field benefit/total variable costs); ^c Conversion rate of 1750 Uganda shillings per US dollar; ^d NPK = (60 kg N + 20 kg P + 25 kg K) ha⁻¹.

Table 6. Farmers' observations on mucuna and inorganic fertilisers as a percentage of the total number of farmers (20) who participated in the trials at Nakisenye

Farmers' observations (%)			
Mucuna			
<i>Benefits</i>		<i>Problems</i>	
High/good crop yields	100	Smothering other plants in an intercrop	70
Improve soil fertility	80	Harbours pest (rats)	30
Weed suppression	100		
Conserves water/ keeps the soil cool	10		
Makes ploughing easier	10		
Fodder for livestock	40		
<i>Best use of mucuna in the system</i>		<i>Proposed solutions to the problems</i>	
Intercrop	40	Manual removal from crop	30
Fallow	70	Use in sole crop	50
		No solution	20
Inorganic fertilisers			
<i>Benefits</i>		<i>Problems</i>	
High/good crop yields	80	Expensive (High cost)	40
Improves soil fertility	40	Encourages excessive weed growth	10
		Not available in the village	60

Doho

Azolla

The results of farmers' evaluation of Azolla and inorganic fertiliser use in the rice system are presented in Table 7. Farmers appreciated the value of alternative sources of N in increasing rice yields, indicating that soil fertility is a problem at Doho and the two sources are effective, which agrees with the yield obtained.

Discussion

Soil characteristics

The mean values of the soil pH were below the low critical value for Uganda soils (Foster, 1971). However the soil chemistry changes under submerged conditions,

the pH changes towards neutral, thus influencing nutrient availability. The mean values of other soil properties indicated that the soils were of average fertility (Table 1). The observed high organic matter levels was due to the fields being submerged for a greater part of the year, the anaerobic conditions retards organic matter decomposition, hence its accumulation. Moreover, deposition of sediments eroded from upland areas, which are often rich in organic matter could also have contributed to the high organic matter contents.

Nakisenye

Maize, mucuna and rice yield

There was no significant difference ($P < 0.05$) in maize grain yield between the mucuna-maize intercrop (3.4 t

Table 7. Farmers' observations on *Azolla* or inorganic fertilisers as a percentage of the total number of farmers (14) who participated in the trials at Doho

Farmers' observation (%)			
<i>Azolla</i>			
<i>Benefits</i>		<i>Problems</i>	
High/good crop yields	100	Dislodges newly transplanted rice seedlings	43
Crops grow fast	43	Shading of rice plants from direct sunlight	71
		Reduces number of tillers	21
		Harbouring pests/insects	8
<i>Proposed solutions to the problems</i>			
Regulating water flow	57		
Incorporating <i>Azolla</i> into the soil	71		
Removing <i>Azolla</i> from the fields	16		
Inorganic fertilisers			
<i>Benefits</i>		<i>Problems</i>	
High/good crop yields	64	Expensive	87
Plants mature early	16	Excessive vegetative growth	21
Increases number of tillers	16	Nil	30

ha⁻¹) and the control – sole maize (3.1 t ha⁻¹), implying that, mucuna did not affect the maize. This was partly attributed to the good management of mucuna by the farmers, that is, by preventing it from smothering the maize through cutting off the vines, and also removing it from the maize stems. However, there was a significant reduction ($P < 0.05$) in mucuna biomass production in relay (6 t ha⁻¹) compared to the fallow (7.6 t ha⁻¹), due in part to the frequent cutting of mucuna vines by farmers. On average, mucuna accumulated 205 kg N ha⁻¹, within the range reported for green manures in the tropical lowland rice systems (Buresh and De Datta, 1991; George et al., 1999; Ladha et al., 1996).

It is observed from Table 2 that there was a significant increase ($P < 0.05$) in rice yield in response to the application of inorganic N fertilizers and to preceding mucuna fallow or relay when compared to the control. Implying that, N was limiting rice production. Several investigators (Becker et al., 1990; Ladha et al., 1996; Becker and Johnson, 1998) reported an increase in rice yield in response to preceding green manures. The lack of significant difference in yield in response to the application of inorganic N fertilizer and preceding mucuna fallow or relay, indicates that the green manure and inorganic N fertilizers are both effective N sources for the rice crop. From the nutrient analysis, it was estimated that approximately 205 kg N ha⁻¹ was applied as mucuna-derived N, which became available to the rice crop through mineralization. Though a large amount of mucuna-derived N was applied, the efficiency of its utilisation by the rice crop was low because a considerable amount was lost since its release was not synchronized with plant demand. George et al. (1998)

reported that up to 32% of the N in the green manures is lost due to excessive amounts often added. Loss of mucuna-derived N partly explains the lack of significant difference between the inorganic N and mucuna treatments.

The lack of a significant difference ($P < 0.05$) between the N with, and without P and K fertilizers implied that, P and K were not limiting rice production at these low yield levels. This also explains the lack of a significant difference in rice grain yield between the treatments with preceding mucuna relay with, and without P and K fertilizers.

There was a significant increase ($P < 0.05$) in rice yield in response to preceding mucuna fallow compared to the weedy fallow due to the N input into the system by mucuna. This further demonstrated the superiority of leguminous short-term fallows to weedy fallows in soil fertility improvement. There was lack of a significant difference in rice grain yield between the weedy fallow and the control indicating that a single season weedy fallow was not adequate as a soil fertility replenishment strategy. This is in agreement with the current recommendation for rotations in Uganda, which is three years of cropping followed by three years under fallow (Foster, 1976).

Doho

Rice yield

The yield data presented in Table 3 indicates a significant increase ($P < 0.05$) in rice yield in response to the

different amendments as compared to the control. The response to the application of 60 kg N ha⁻¹ was similar to that of Azolla incorporation. Thus Azolla-derived N was as effective as the applied inorganic N fertilizers. The increase in rice yield following the incorporation of Azolla was in agreement with the results reported in Asia (Watanabe, 1982; Lumpkin and Plucknett, 1982; Kumarasinghe and Eskew, 1993).

The overall rice production over two seasons indicated a significant increase in rice yield in response to the application of N, P and K fertilizers compared to N fertilizers only, indicating that P and K were also limiting rice production at this site. However a larger increase in rice yields was in response to N, implying that N was the major limiting nutrient.

The lack of a significant difference in rice yield between N, P, and K with, and without Azolla, implied that Azolla might have contributed less N to the system through biological N fixation. This is partly attributed to the application of inorganic N to which Azolla might have relied on for its N requirements, hence competing with the rice crop. The inorganic N fertilizer may also have inhibition BNF of the Azolla. It is well established that soluble N inhibits biological N fixation (Herridge et al., 1990; Herridge and Danso, 1995; Giller and Cadisch, 1995).

Economic analysis

Nakisenye

The partial budget presented in Table 4 indicated high economic returns with all the alternative strategies. Since rice was basically for the local market, producer prices do not fluctuate much. The high returns obtained even with the current farmers' practice, explains the extensive clearing-taking place in the swamps by farmers for rice cultivation in eastern Uganda. Using mucuna, the relay gave the highest benefit to cost ratio. Even with the complete season crop lost by farmers when fields were under mucuna fallow, the increase in yield during the subsequent season compensated for this loss. The addition of P and K fertilizers to mucuna relay reduced the benefit to cost ratio due to the high cost of the fertilizers, as the increase in yield was not proportional to the extra costs incurred. Adoption of mucuna is therefore a viable alternative to the current system of non-use of external inputs, which is unsustainable in the long run as observed from the extensive clearing of swamps.

Application of 60 kg N ha⁻¹ was as profitable as the farmers' current practice, due to high cost of the inorganic fertilizers. The addition of P and K fertilizers reduced the benefit to cost ratio, and even there was no significant difference in yield between the N with, and without P and K treatments. Therefore at current yield levels, inorganic fertilizers are not economical and there is little incentive for farmers to adopt fertilizers!

The results from the sensitivity analysis (data not shown) of the effect of reduction in fertilizer prices revealed that, N, P, K fertilizer prices would have to come down by 25% for the farmers to break even. That is for the B/C ratio of the NPK treatment to be above that of the current farmers practice. In the case of combining mucuna relay with P and K, a reduction of more than 50% would be needed to profit from a shift to fertilizer use. To achieve a substantial reduction in fertilizer price require government intervention at policy level.

Doho

Inorganic fertilizers or *Azolla* were more profitable than the current farmers' practice, due to the significant increase in rice grain yield from the use of these strategies (Table 5). The benefit to cost ratio from N, P, and K fertilizers was similar to that of N fertilizer alone, indicating that additional increase in grain yield in response to the application of P and K covered the extra cost of the fertilizers. However, application of N, P, K fertilizers together with *Azolla* reduced the benefit to cost ratio compared to either strategy used alone. This was due to the extra costs incurred, which were not compensated with a proportional increase in grain yield.

Farmer's evaluation of green manure and inorganic fertilizers

Nakisenye

It was observed from that 80–100% of the farmers appreciated the value of mucuna and inorganic fertilizers in improving soil productivity and increasing crop yields (Table 6). Additional benefits for mucuna mentioned/observed by farmers included weed suppression and ease of field preparation or ploughing during the subsequent season, which reduced labour requirements, resulted to early field preparation, hence timely planting. In addition, 10% of the farmers appreciated the value of mucuna in conserving soil moisture and keeping the soil cool mainly because of its mulching

effect. Farmers' made similar observations in central-eastern Uganda (Fischler and Wortmann 1999) and in Honduras (Buckles and Triomphe, 1999). Farmers (40%) reported that animals grazed on mucuna implying that it can be used as fodder for livestock, which is important in the farming system because fodder is of poor quality, and inclusion of legumes is being advocated as one way of improving fodder quality.

However, farmers reported problems associated with mucuna, with 70% observing smothering of other plants in intercrops. The solutions proposed by farmers included manual removal, but the majority preferred using it in sole crop, that is, as a fallow.

A large number of farmers appreciated the value of inorganic fertilizers in increasing crop yields, indicating that soil fertility was a major problem and fertilizers were effective in increasing crop yields (Table 7). The problems mentioned by the farmers for instance high cost, were the common ones often reported as limiting the use of fertilizers in sub-Saharan Africa (Vlek, 1990; Sanchez, 2002). The economic analysis of our experiments arrived at similar conclusions. Non-availability of inorganic fertilizers in the area was due to low use hence dealers were not ready to invest in taking fertilizers to these areas because the rate of stock turnover and the returns were low.

Doho

The results presented in Table 7 indicates that all the farmers who participated in the study appreciated the value of Azolla in increasing rice yields, because it was an effective source of N and as such could address one of the factors limiting rice production at Doho. However some farmers' associated Azolla with some problems. The major ones reported by 43–71% of the farmers were shading of rice plants and dislodging newly transplanted rice seedlings. A close observation indicated that these problems were mainly due to poor regulation/control of irrigation water and non-use of Azolla. For instance the dislodging of newly transplanted rice by a dense mass of Azolla floating on the surface of un-regulated floodwater. In addition, the dense mass also shade the young rice plants from sunlight, reducing their photosynthetic activities, thus affecting growth and subsequent yield. Control of irrigation water and incorporating Azolla were potential solutions to the problems as suggested by the farmers.

The problem of Azolla harbouring insects/pests was due to attack by a large number of insect larvae, which

might not necessarily be pests for rice crop. Boddey et al. (1997) and Giller (2001) reported that damage by insects was one of the most important factors leading to poor performance of Azolla. The insects/pests are normally controlled through spraying, which unfortunately will be an additional cost to the already resource constrained farmers!

Similarly all farmers appreciated the value of inorganic fertilizers in increasing rice yields, indicating that soil fertility was a major problem in the Doho rice scheme. Further fertilizers were seen to be effective as evident in the yield responses obtained. The problems mentioned by farmers were the usual ones limiting the use of fertilizers in sub-Saharan Africa (Vlek, 1990; Sanchez, 2002). The fact that 87% of the farmers mentioned cost as a problem indicated that farmers at the scheme had experience with fertilizer use. Some farmers at the scheme used fertilizers because rice had a ready market and the prices were high. Market availability was one of the pre-requisite for adoption of the improved technologies.

Conclusion

Inorganic fertilizers and green manures are effective strategies for increasing rice yields for resource poor farmers in eastern Uganda. The farmers' favorable evaluation of the alternative strategies confirmed that inorganic fertilizers and green manures were potential resources for addressing the problem of low N supply, a major limiting factor for crop production in the region. Farmers' recognized the additional benefits from mucuna, though primarily investigated as a source of N. Proper control of irrigation water and farmers' appreciation of the value of Azolla will lead to its use as a source of N in the rice system rather than considering it as an obnoxious weed. The economic analysis indicated that adoption of Azolla, mucuna and inorganic fertilizers in rice production was profitable due to the high price of rice. There are benefits (agronomic and economic) from the use Azolla, mucuna and inorganic fertilizers, which farmers should take as incentives to change from the current unsustainable non- or low-use of external inputs agriculture.

Acknowledgements

The authors are grateful to the farmers, and to the field assistants Mr. Kibubula and Mr. Mbayo, at Nakisenye

and Doho, respectively, for the good work done. This work was part of the project on policies for improved land management in Uganda with the following collaborating institutions: International Food Policy Research Institute, Center for Development Research – University of Bonn, Agricultural Policy Secretariat – Bank of Uganda, and Makerere University.

References

- Anderson J.M., Ingram S.J. 1993. *Tropical Soil Biology and Fertility: A Handbook of Methods*. CAB Int. Wallingford, England. 221 p.
- Bekunda M.A., Bationo A. and Ssali H. 1997. Soil Fertility Management in Africa. A review of selected research trials. In: Buresh R. J., Sanchez P.A., Calhoun F., (Eds.) *Replenishing soil fertility in Africa*. SSSA spec. Publ. 51 SSA, Madison WI, pp 63–79.
- Becker M. and Johnson D.E. 1998. Legumes as dry season fallow in upland rice-based farming systems of West Africa. *Biol Fertil Soils* 27: 358–367.
- Becker M., Ladha J.K. and Ottow J.C.G. 1990. Growth and N₂ fixation of two stem nodulating legumes and their effects as green manure on lowland rice. *Soil Biol. Biochem.* 22: 1109–1119.
- Boddey R.M., Moraes J.C., Alves J.B.R. and Urquiaga S. 1997. The contribution of Biological Nitrogen Fixation for sustainable agricultural systems in the tropics. *Soil Biol. Biochem.* 29: 787–799.
- Buckles D. and Triomphe B. 1999. Adoption of mucuna in the farming systems of northern Honduras. *Agrofor. Syst.* 47: 67–91.
- Buresh R.J. and De Datta S.K. 1991. Nitrogen dynamics and management in rice-legume cropping systems. *Adv. Agron.* 45: 1–59.
- CIMMYT 1988. *From Agronomic Data to Farmer Recommendations: An Economics Training Manual*. Completely revised edition. Mexico, D.F.
- Eskew D.L. 1987. Use of ¹⁵N in N₂ fixation and N cycling studies of *Azolla*. In: *Azolla Utilization*. Proceedings of a workshop on Azolla Use, Fuzhou, Fujian, China, 31 Mar.- 5 Apr. 1985. IIRI, Los Baños. The Philippines, pp. 233–239.
- Foster H.L. 1971. Rapid routine soil and plant analysis without automatic equipment. I. Routine Soil analysis. *E. Afric. Agric. For. J.* 37: 160 – 170.
- Foster H.L. 1976. *Soil Fertility in Uganda*. PhD thesis. Univ. of Newcastle Upon Tyne, England.
- Fischler M. and Wortmann C.S. 1999. Green manures maize-bean systems in eastern Uganda: Agronomic performance and farmers' perceptions. *Agrofor.Syst.* 47: 123–138.
- George T., Buresh R.J., Ladha J.K. and Punzalan G. 1998. Recycling in situ of Legume-Fixed and Soil Nitrogen in Tropical Lowland Rice. *Agron. J.* 90: 429–437.
- George T., Ladha J.K., Garrity D.P. and Buresh R.J. 1994. Legumes as nitrate catch crops during dry-to-wet transition in lowland rice cropping systems. *Agron. J.* 86: 267–273.
- Giller K.E. 2001. *Nitrogen Fixation in Tropical Cropping Systems*. 2nd Edn, CAB International, Wallingford, 423p.
- Giller K.E. and Wilson K.J. 1991. *Nitrogen Fixation in Tropical Cropping Systems*. CAB International, Wallingford, 313p.
- Giller K.E. and Cadisch G. 1995. Future benefits from biological nitrogen fixation: An ecological approach to agriculture. *Plant and Soil* 174: 255–277.
- Giller K.E., McDonagh J.F. and Cadisch G. 1994. Can biological nitrogen fixation sustain agriculture in the tropics? In: Syers J.K. and Rimmer D.L. (Eds.) *Soil Science and sustainable land management in the tropics*. CAB Int., Wallingford, England, pp. 173–191.
- Giller K.E., Cadisch G., Ehakuitum C., Adams E., Sakala W.D. and Mafongoya P.L. 1997. Building soil nitrogen capital in Africa. In: Buresh R.J., Sanchez P.A., Calhoun F. (Eds.), *Replenishing soil fertility in Africa*. SSSA spec. Publ. 51 SSSA, Madison, EI, pp. 151–192.
- Herridge D.F. and Danso S.K.A. 1995. Enhancing legume N₂ fixation through selection and breeding. *Plant and Soil* 174: 51–82.
- Herridge D.F., Bergersen F.J. and Peoples M.B. 1990. Measurement of nitrogen fixation by soybean in the field using the ureide and natural abundance methods. *Plant Physiol.* 93: 708–716.
- Kikuchi M., Watanabe I. and Haws L.D. 1984. Economic evaluation of *Azolla* use in rice production. In: *Organic matter and Rice*. IIRI, Los Banos, Philippines, pp. 569–592.
- Kumarisinghe K.S. and Eskew B.L. (Eds.) 1993. *Isotopic Studies of Azolla and Nitrogen Fertilization of Rice*. Kluwer Academic Publishers, Dordrecht, Netherlands.
- Ladha J.K., Kundu D.K., Angeno M.G., van Coppenolle B., Peoples M.B., Carangal V.R. and Dart. P.J. 1996. Legume Productivity and Soil Nitrogen Dynamics in Lowland Rice-Based Cropping Systems. *Soil Sci. Soc. Am. J.* 60: 183–192.
- Lumpkin T.A. and Plucknett D.L. 1982. *Azolla as a Green manure: Use and Management in Crop Production*. Westview Press, Boulder, Colorado.
- Peoples M.B., Herridge D.F. and Ladha J.K. 1995. Biological nitrogen fixation: an efficient source of nitrogen for sustainable agriculture? *Plant Soil* 174: 3–28.
- Sanchez P.A. 2002. *Soil Fertility and Hunger in Africa*. Science 295 : 2019–2020.
- Sanchez P.A., Izac A.M.N. Valencia I. and Pieri C. 1996. Soil Fertility Replenishment in Africa; A concept note. In: Breth S.A. (Ed.) *Achieving greater impact from research investments in Africa*. Sasakawa Africa Assoc, Mexico City, pp. 200–207.
- Sanchez P.A., Sheperd K.D., Soule M.J., Place F.M., Buresh R. J., Izac A.M.N., Mkwunye A.V., Kwasiga F.R., Ndiritu C.G. and Woome P.L. 1997. Soil Fertility replenishment in Africa: An investment in natural resource capital. In: Buresh R. J., Sanchez P.A. and Calhoun F. (Eds.) *Replenishing Soil Fertility in Africa*. SSSA spec. Publ. 51. SSSA, Madison, WI. pp. 1–46.
- Statistix for Windows 1998. Analytical Software, Tallahassee, FL. USA.
- Stoorvogel J.J. and Smaling E.M.A. 1990. Assessment of soil nutrient depletion in sub-Saharan Africa, 1983–2000. Rep. 28 Win and Staring ctr, for Integrated Land, Soil and Water Res., Wageningen, the Netherlands.
- Van Cleemput O. 1995. Fertiliser, Sustainable Agriculture and Preservation of the Environment. In: IAEA (Ed.) *Nuclear methods in Soil-Plant aspects of Sustainable Agriculture*. Proceedings of an FAO/IAEA Regional Seminar for Asia and Pacific held in Colombo, Sri Lanka, 5-9 April 1993. IAEA-TECDOC-785. Vienna, Austria, pp. 7–16.
- Vlek P.L.G. 1990. The role of fertilisers in sustaining agriculture in sub-Saharan Africa. *Fert. Res.* 26: 327–339.
- Vlek P.L.G. 1993. Strategies for sustaining agriculture in sub-Saharan Africa. In: Rogland J. and Lal R. (Eds.) *Technologies for sustaining*

- agriculture in the tropics, ASA Spec. Publ. 56. ASA, CSSA, and SSSA, Madison, WI, pp 265–277.
- Watanabe I. 1982. *Azolla-Anabaena* symbiosis – its physiology and use in tropical agriculture. In: Dommergues Y.R. and Diem H.G. (Eds.) *Microbiology of Tropical Soils and Plant Productivity*, Martinus Nijhoff, The Hague, pp. 168–185.
- Watanabe I., Yoneyama T., Talukdar H. and Ventura W. 1991. The contribution of Nitrogen fixation to *Azolla* spp grown on flooded soils. *Soil Sci and Plant Nutr* 37: 101–110.
- Wortman C.S. and Kaizzi C.K. 1998. Nutrient balances and expected effects of alternative practices in farming systems of Uganda. *Agric. Ecosystem. Environ.* 71: 115–129.

Tied-ridging and integrated nutrient management options for sustainable crop production in semi-arid eastern Kenya

Miriti J.M.¹, Esilaba A.O.², Bationo A.³, Cheruiyot H.², Kihumba J.¹ and Thurairira E.G.⁴

¹National Agricultural Research Centre, Kenya Agricultural Research Institute, P.O. Box 30148, Nairobi, Kenya. Email: jmmiriti@yahoo.co.uk; ²Desert Margins Programme, Kenya Agricultural Research Institute, P.O. Box 57811, Nairobi, Kenya. Email: aoesilaba@kari.org; ³Tropical Soil Biology and Fertility Institute of CIAT (TSBF-CIAT) c/o World Agroforestry Centre (ICRAF), United Nations Avenue, Gigiri, P.O. Box 30677 Nairobi, Kenya. Email: A.Bationo@cgiar.org; ⁴National Agricultural Research Laboratories, Kenya Agricultural Research Institute, P.O. Box 14733 Nairobi, Kenya.

Abstract

A field experiment was conducted for two seasons at Emali, Makueni District in Eastern Kenya to compare the effect of tied ridging and integrated nutrient management practices on the yield of rainfed maize (*Zeamays L.*) and cowpeas (*Vigna unguiculata L.*). The main treatments were flat bed (FB, traditional farmers' practice) and tied ridging (TR) as main plots. The manure and fertilizers were farmyard manure (FYM, goat manure at 0 and 5 t ha⁻¹) in a factorial combination with nitrogen (N fertilizer at 0, 40, 80 and 120 kg N ha⁻¹) and P fertilizer at 0 and 40 kg P ha⁻¹ as the subplots in a split-plot treatment arrangement of a randomized complete block design (RCBD). Results from maize yield data in the continuous maize cropping systems indicate that maize stover was significantly ($P \leq 0.05$) increased by the application of 5 t ha⁻¹ of manure in both seasons. Tied ridges, manure and fertilizer did not affect grain yields in the first season. However, mean grain yields obtained in plots with tied-ridges and manure were higher by 11% and 14% compared to plots without tied ridges and manure respectively. There was a significant interaction between manure and nitrogen which gave higher stover yields in the 2003 long rains season. Under the cowpeas–maize intercropping system, tied ridges and manure application did not have a significant effect on maize yields in both seasons. Application of nitrogen significantly ($P \leq 0.05$) increased maize stover by 29% and TDM yields by 50% in first and second season respectively when compared with treatments without nitrogen. Nitrogen application also increased cowpea stem and TDM yields by 57% and 45% respectively in the second season. Cowpea yields were not affected by tied-ridges in both seasons. There was significant effects of manure, nitrogen, manure * nitrogen and tied ridging * nitrogen interactions on cowpea stem and TDM in 2003 short rains season. In general, the combination of tie-ridges with manure or nitrogen gave higher maize and cowpea yields than when these factors are applied alone. These preliminary results indicate that tied ridging in combination with integrated nutrient management has the potential to improve crop production in semi-arid eastern Kenya

Key words: Arid and semi arid lands, cowpea, integrated nutrient management, tied ridging

Introduction

Approximately 83% of Kenya is classified as the arid and semi-arid (ASALs). The ASALs are characterized by low and erratic rainfall (100–900 mm

per annum), high transpiration rates, scattered vegetation and generally fragile ecosystems which is not suitable for permanent rainfed agriculture (Keating et al., 1992). Dry spell analysis by Barron (2004) in two locations in semi-arid eastern Kenya indicate

that potentially yield-limiting dry spells occur at least 75% of the seasons during a 20-year period. Despite the environmental limitation, the marginal areas are experiencing the greatest population change as land for agriculture becomes more scarce in the wetter highlands (McCown and Jones, 1992). Consequently, food production has lagged behind population growth in these areas to the extent that majority of smallholder farmers cannot adequately provide for their livelihood.

High risk of crop failure due to drought and dry spells leads to reluctance by smallholder farmers to invest on cropland (Brouwer and Bouma, 1997). Which suggests that drought and dry spell mitigation through better on-farm rainwater management could be the key to improved crop production in the current farming systems in arid areas (Rockström, 2003). The potential of improving crop production through use of rainwater harvesting and soil fertility management is widely cited (Biamah et al., 2000; Mellis, 1996; Njihia, 1977; Liniger, 1990). Different water harvesting techniques (i.e., level basin, tied ridges and conventional tillage) have been compared for their water retention, availability and suitability to crop production. Results from tied ridges techniques have given superior yields for different crops (Miriti et al., 2003; Kipserem, 1996). However, tied ridging is also reported to give contradictory results as the net effects of tied ridging can be both positive and negative partly because of variation of in soil and climatic characteristics among sites and between years (Lal, 1995). Most studies have also not taken into consideration the interactions with cropping systems and nutrient management variability in farming systems. Jensen et al. (2003) have reported enhanced crop response to rainfall and fertilizer, the soil supply of available N and crop yields as a result of ridging. Furthermore, other studies have shown that low crop yields levels may persist even with increased soil moisture if plant nutrients in the soil are inadequate (Fox and Rockström, 2003). The combined use of rainwater harvesting and nutrient management holds the key to ensuring higher and sustainable agricultural productivity in these areas.

Soil fertility in the ASALs is low particularly where continuous cultivation without nutrient replenishment is practiced (Probert et al., 1992). Reports indicate that farmyard manure is the most widely used to improve soil fertility for crop production in the Kenyan ASALs (Freeman and Coe, 2002). However, farmers have indicated that there were inadequate quantities of animal manure in relation to farm requirements and high labour demands as the most important constraints to use of animal manure (Omiti et al., 1999). Integrating tied ridging with manure and inorganic fertilizers could result in considerable crop yield increases in farmers' fields because of improved water and nutrient availability. Although integration of water harvesting and nutrient management is important in increasing and sustaining crop production, and also the maximization of the return from inputs such as fertilizers, there is limited knowledge on their interaction and crop response in the drylands of Kenya. The objective of this study was therefore to assess the effects of tied-ridging and integrated nutrient management on crop production in semi-arid eastern Kenya.

Materials and methods

Site description: The study was conducted for two seasons at Emali in the semi-arid areas of Makueni District in eastern Kenya in 2003 (Jaetzold and Schmidt, 1983). The site has bimodal distribution of rainfall which is low and erratic. The short rains occur in October to January and the long rains in March to June. Temperatures are high giving rise to high evapotranspiration. The experimental sites soil chemical characteristics are presented in Table 1. The methods for soil analysis were: pH (H₂O) in a 1:1 soil/water suspension; organic C by wet oxidation, available P by Bray 2, exchangeable bases (Ca²⁺, Mg²⁺, K⁺ and Na⁺) by Ammonium Acetate extraction (Okalebo et al., 2002). The soils are Ferralsols and their chemical properties at 0–20 cm indicate that they are acidic (pH 4.8), while % organic carbon, % total N, available P, exchangeable K were low, moderate,

Table 1. Soil chemical characteristics of the topsoil (0–20cm) at Emali

PH (1:2.5 H ₂ O)	% Org C	% Total N	Bray P2 P (ppm)	NH ₄ OAC EXT. K (ppm)	NH ₄ OAC EXT. Mg (ppm)	NH ₄ OAC EXT. Ca (ppm)	NH ₄ OAC EXT. Na (ppm)	CECC mol/Kg (soil)
4.86	1.07	0.14	314.74	218.33	263.51	340.33	17.12	2.58

Table 2. Crop management and fertilizer application rates *

Crop rotation	Cowpea (P40, N0)	Maize (P40, N0)	Cowpea (P40, N40)	Maize (P40, N40)
Intercrop	Cowpea/ Maize (P40, N0)	Maize (P0, N0)	Cowpea/ Maize (P40, N40)	Cowpea (P0, N0)
Continuous Cropping	Maize (P40, N0)	Maize (P40, N40)	Maize (P40, N80)	Maize (P40, N120)

*P0 = 0 kg P ha⁻¹; P40 = 40 kg P₂O₅ ha⁻¹; N0 = 0 kg N ha⁻¹; N40 = 40 kg N ha⁻¹; N80 = 80 kg N ha⁻¹; N120 = 120 kg N ha⁻¹.

very high and very high respectively (Okalebo et al., 2002).

Experimental layout and treatments: The experimental design was split-split-split plot with water harvesting versus conventional tillage as the main plots; and manure versus no manure application as the sub-plots. The sub-plots were split into three cropping systems i.e., (1) legume–cereal rotation, (2) legume–cereal intercrop and (3) continuous cereal as shown in Table 2. Each treatment was replicated four times in a randomized complete block design (RCBD).

Tillage: Tied-ridges were used as the water harvesting method. Ridges (30 cm high) and ties (cross ridges, 20 cm high) were constructed to create a series of basins for storing water. The spacing of the ridges was 90 cm and the cross ridges were made at 2.5 m interval using a hand hoe to prevent flow of runoff and ensure an even spread of captured water.

Fertilizer application: In each cropping system different fertilizer treatments were applied as indicated in Table 2. Goat manure was applied at 5 t ha⁻¹ (Kihanda et al., 2004). The applied manure contained 1.7% N, 0.72% P, 3.66% K, 2.23% Ca and 0.59% Mg. Phosphorus (P) fertilizer was applied at 0 and 40 kg P₂O₅ ha⁻¹ and nitrogen (N) at 0, 40, 80 and 120 kg N ha⁻¹ depending on the treatment requirements. Triple superphosphate (TSP) and Calcium ammonium nitrate (CAN) fertilizers were used as source of P and N respectively.

Planting: Maize (*Zea mays* L., Dryland Composite hybrid variety) and cowpea (*Vigna unguiculata* L., K80 variety) were used as the test crops. Maize and cowpeas were planted during the long rains (LR) and short rains (SR) of 2003 in 25 m² plots. Maize and cowpeas spacing was 90×30 cm in pure stands while in the intercropping system, maize and cowpea was planted in the same row but in alternating hills at the same spacing. The crops were dry planted before the onset of the rains in each season. Thinning was done to a single plant per hill one month after planting. The thinned cowpea

and maize plants were sampled for dry matter biomass yield determination. The final maize and cowpea seed and dry matter yields were determined at harvesting time by sampling the inner 3 m by 1.8 m area of each plot. All plant data were subjected to statistical analyses using Genstat statistical package and the treatments were separated using the Least Significant Difference (LSD) test.

Results

Maize dry matter and grain yields

Maize yields data in the continuous maize cropping system is presented in Table 3. Maize yields in the continuous cropping system indicate that total dry matter yield (TDM) and maize stover yields were significantly ($P \leq 0.05$) increased by manure application during the first season (LR 2003). Tied ridges, manure and fertilizer did not significantly affect grain yields. However, mean grain yields obtained in plots with tied ridges and manure were higher than plots without these treatments. A combination of tie-ridges with manure or nitrogen gave higher maize yields than when these factors are applied alone, but yield increases were not significant. Although tie-ridging and manure application increased TDM by 7% (from 6.56 to 7.04 t ha⁻¹) and 16% (from 6.29 to 7.30 t ha⁻¹), this change was also not significant at 5%. However, there was a significant ($P = 0.05$) interactions between manure and N on maize stover and TDM yields during the season.

During the second season (SR 2003), the application of nitrogen and manure separately increased maize dry matter yield at thinning and TDM yields significantly ($P_{0.05}$) in the continuous maize cropping system (Table 3). Total dry matter yields were increased by 55% after manure application. In the nitrogen treatments the highest TDM yields were observed with 80 kg N ha⁻¹ but this was not significantly different from 40 kg N ha⁻¹ and 120 kg N ha⁻¹. The effects of tillage

Table 3. Effects of tied ridges, manure and nitrogen application on maize under the continuous maize cropping system

Treatment	Long Rains 2003				Short Rains 2003	
	Thinning g plant ⁻¹	Stover t ha ⁻¹	Grain t ha ⁻¹	TDM t ha ⁻¹	Thinning g plant ⁻¹	TDM t ha ⁻¹
Water harvesting						
No tied ridging	24.4	3.38	2.18	6.56	20.2	2.97
Tied ridging	34.8	3.46	2.43	7.04	22.1	3.70
LSD (0.05)	ns	ns	ns	ns	ns	ns
Manure						
0 t ha ⁻¹	27.1	3.08	2.16	6.29	17.6	2.67
5 t ha ⁻¹	32.1	3.76	2.46	7.30	24.7	4.00
LSD (0.05)	ns	0.58	ns	1.03	6.9	0.75
Nitrogen						
0 kg N ha ⁻¹	36.6	3.64	2.8	7.74	16.0	2.3
40 kg N ha ⁻¹	31.4	3.01	2.37	6.45	24.3	3.66
80 kg N ha ⁻¹	26.8	3.43	2.24	6.70	24.6	4.18
120 kg N ha ⁻¹	23.6	3.60	1.84	6.30	19.7	3.19
LSD (0.05)	ns	0.76	ns	ns	6.8	0.90
P > F						
Water harvesting	0.147	0.839	0.500	0.475	0.237	0.079
Manure	0.176	0.030	0.40	0.052	0.045	0.005
Nitrogen	0.187	0.329	0.059	0.191	0.041	0.001
Tr * M	0.047	0.371	0.621	0.304	0.801	0.605
Tr * N	0.559	0.245	0.769	0.601	0.734	0.200
M * N	0.486	0.020	0.259	0.065	0.278	0.138
Tr * M * N	0.998	0.412	0.698	0.690	0.488	0.271

Tr = Tied ridges; N = nitrogen; M = manure; ns = not significant.

on TDM was not significant although mean TDM yields were 25 % higher in tied ridges plots than in flat tillage.

Under cowpea–maize intercropping systems (Table 4), the maize yields were not significantly affected by tie-ridging and manure application during both seasons. However, application of nitrogen significantly ($P \leq 0.05$) increased stover and TDM yields by 29% and 50% in LR 2003 and SR 2003 respectively when compared with treatments without nitrogen. Application of N significantly ($P \leq 0.05$) increased maize dry matter at thinning by 22% (from 34.8 to 42.5 t ha⁻¹) and 32% (13.0 to 19.4 g plant⁻¹) in the first and second season respectively. There was a significant positive interaction between manure and tied-ridging on the maize dry matter yields at thinning in the LR 2003 season.

Cowpea dry matter and grain yields

Cowpea yields were not significantly affected by either tied ridges, manure or nitrogen application during the LR 2003 season (Table 5). The total dry matter yields

were 43% lower in tied ridges than in the flat cultivation treatments during the LR 2003 season. The TDM yields obtained from manure and N treatments during LR 2003 were similar (3.00 t ha⁻¹ and 3.01 t ha⁻¹ respectively) and were 10% higher than where these factors were not applied. However, there was a significant interaction between tied ridging, manure and nitrogen on the cowpea TDM.

During the SR 2003 season, addition of nitrogen significantly increased cowpea stem and TDM yields in the intercrop by 57% and 45%, respectively. Whereas manure significantly increased cowpea TDM and dry matter at thinning, cowpea yields response to tied-ridging was not significant. The manure * nitrogen and tied ridging * nitrogen interactions also had a significant influence on cowpea TDM. Similar interactions were observed between manure * nitrogen and tied ridging * nitrogen on stem yields and manure * nitrogen on cowpea at thinning in the short rains season. Their combined effects resulted in higher stem dry matter yields. Generally, tied ridges, manure and nitrogen application did not have significant effects on cowpea grain yields.

Table 4. Effects of tied ridges, manure and nitrogen application on maize yields under the cereal–legume intercropping system

Treatment	Long Rains 2003				Short Rains 2003	
	Thinning g plant ⁻¹	Stover t ha ⁻¹	Grain t ha ⁻¹	TDM t ha ⁻¹	Thinning g plant ⁻¹	TDM t ha ⁻¹
Water harvesting						
No tied ridging	41.2	3.29	2.40	6.70	16.0	1.99
Tied ridging	36.1	2.73	1.70	6.27	16.4	2.41
LSD (0.05)	ns	ns	ns	ns	ns	ns
Manure						
0 t ha ⁻¹	36.5	3.01	2.25	6.74	13.9	1.83
5 t ha ⁻¹	40.8	3.01	1.86	6.23	16.4	2.57
LSD (0.05)	ns	ns	ns	ns	ns	ns
Nitrogen						
0 kg N ha ⁻¹	34.8	2.63	1.95	5.43	13.0	1.76
40 kg N ha ⁻¹	42.5	3.39	2.15	6.53	19.4	2.64
LSD (0.05)	ns	0.76	ns	ns	5.9	0.65
P > F						
Water harvesting	0.528	0.258	0.159	0.151	0.914	0.095
Manure	0.248	0.987	0.143	0.497	0.131	0.134
Nitrogen	0.210	0.051	0.424	0.066	0.040	0.012
Tr * M	0.045	0.730	0.514	0.949	0.100	0.881
Tr * N	0.481	0.388	0.302	0.251	0.287	0.215
M * N	0.139	0.077	0.415	0.506	0.967	0.358
Tr * M * N	0.443	0.650	0.823	0.142	0.332	0.592

Tr = Tied ridges; N = nitrogen; M = manure; ns = not significant.

Table 5. Effects of tied ridges, manure and nitrogen application on cowpeas under legume–cereal intercropping system

Treatment	Long Rains 2003		Short Rains 2003			
	Thinning g plant ⁻¹	TDM t ha ⁻¹	Thinning g plant ⁻¹	Stem t ha ⁻¹	Grain Kg ha ⁻¹	TDM t ha ⁻¹
Water harvesting						
No tied ridging	11.8	3.65	2.83	1.63	149	1.85
Tied ridging	8.8	2.08	2.87	1.38	252	1.77
LSD (0.05)	ns	ns	ns	ns	ns	ns
Manure						
0 t ha ⁻¹	11.8	2.73	3.17	1.36	211	1.68
5 t ha ⁻¹	8.8	3.00	2.53	1.66	190	1.94
LSD (0.05)	ns	ns	0.52	ns	ns	0.34
Nitrogen						
0 kg N ha ⁻¹	11.2	2.72	2.54	1.17	198	1.48
40 kg N ha ⁻¹	9.5	3.01	3.16	1.84	203	2.14
LSD (0.05)	ns	ns	0.63	0.35	ns	0.40
P > F						
Water harvesting	0.096	0.174	0.924	0.400	0.108	0.717
Manure	0.264	0.725	0.024	0.431	0.595	0.477
Nitrogen	0.274	0.255	0.054	0.001	0.910	0.004
Tr * M	0.855	0.660	0.206	0.579	0.098	0.388
Tr * N	0.695	0.850	0.930	0.039	0.195	0.036
M * N	0.911	0.106	0.012	0.013	0.457	0.015
Tr * M * N	0.061	0.007	0.570	0.415	0.107	0.904

Tr = Tied ridges; N = nitrogen; M = manure; ns = not significant.

Discussions

Maize and cowpea yields responses to tie-ridging was not significant in both seasons. Maize yields comparisons between manure and tied ridges treatments indicate that manure had higher influence on crop yields than tied ridges alone. This indicates that maize crop responded more to soil fertility improvement than soil moisture. The low influence of tied ridges on maize and cowpeas growth may be partly due to moderate soil nitrogen nutrient status in the experimental site which might have caused inadequate N supply. Visual observations also showed that maize plants in treatments without N fertilizer were yellow and stunted indicating nitrogen stress. In the continuous maize cropping system, maize yields obtained from the application of 80 kg N ha⁻¹ were not statistically different from that with N at 40 kg ha⁻¹. This suggests that addition of 40 kg N is enough to meet maize N requirements at the site. Studies conducted elsewhere in the semi-arid areas have also indicated that N fertilizer application above 50 kg ha⁻¹ did not increase maize yields (Kamoni et al., 2003). The increased maize yields when nitrogen is supplemented with water harvesting (and manure) than either of them applied separately suggests enhanced water and fertilizer use efficiency because of the combined response (Jensen et al., 2003). Jensen et al. (2003) have reported enhanced maize response to rainfall and fertilizer on maize grain yields where tied ridges have been used compared to flat cultivation. They found that 98% of the variance in yields could be attributed to the combined response to annual rainfall, N and P fertilizer under tied-ridged conditions in Tanzania. Similar results from the semi-arid areas of eastern Kenya show that water harvesting had little effects on crop response in treatments without fertility improvements (Gichangi *et al.*, 2003). Addition of nitrogen significantly increased cowpea TDM yields in the second season only. However, separate application of nitrogen, manure or tied-ridging did not affect cowpea grain yields during the short rains in 2003.

Conclusions

The results from this study show that although tied ridges increased maize response in some cases, addition of manure and N application still performed better. Application of N together with water harvesting and/or with manure resulted in higher crop yields than either of them applied alone. In a continuous cropping system,

the results have shown that the optimum maize yields were obtained from the application of 40 kg N ha⁻¹. This suggests that addition of fertilizer rates higher than 40 kg N ha⁻¹ does not result in increased crop yields. The cowpea grain yield was not increased by addition of nitrogen and manure or tie-ridging during the first season (long rains 2003). These results suggest that, to achieve better result from water harvesting, there is need to integrate soil fertility management and water harvesting techniques. These preliminary results indicate that tied ridging in combination with integrated nutrient management has the potential to improve crop production in semi-arid eastern Kenya.

Acknowledgements

The authors acknowledge Kenya Agricultural Research Institute (KARI) and Tropical Soil Biology and Fertility Institute of CIAT (TSBF-CIAT) through the Desert Margins Programme for funding this study. This paper has been published with permission from Director of Kenya Agricultural Research Institute.

References

- Barron J. 2004. Dry spell mitigation to upgrade semi-arid agriculture: Water harvesting and soil nutrient management for small holder maize cultivation in Machakos, Kenya. PhD. Thesis, Stockholm University, Sweden.
- Biamah E.K., Rockstrom J. and Okwach G.E. 2000. Conservation tillage for dryland farming. Technical options and experiences in eastern and Southern Africa. Workshop report NO. 3. RELMA, SIDA, Kenya, 151p.
- Brouwer J. and Bouma J. 1997. Soil crop growth variability in Sahel: Highlights of research (1990–1995) at ICRISAT Sahelian Centre. *Information bulletin. No. 49*. ICRISAT, Patancheru 502 324, Andhra Pradesh, India, p. 42.
- Fox P. and Rockström J. 2003. Supplemental irrigation for dry-spell mitigation of rainfed agriculture in the Sahel. *Agricultural Water Management* 1817: 1–22.
- Freeman H.A. and Coe R. 2002. Smallholder farmers' use of integrated nutrient management strategies: patterns and possibilities in Machakos District of Eastern Kenya. In: Barret C.B., Place F. and Aboud A.A. (Eds). *Natural Resources Management in African Agriculture: Understanding and Improving Current Practices*. CAB. International Wallingford, UK, pp.143–154.
- Gichangi E.M., Njiru E.N., Itabari J.K., Wambua J.M. and Maina J.N. 2003. Assessment of improved soil fertility and water technologies through community based on-farm trials in the ASALs of Kenya. A Paper presented at the 1st KARI Adaptive Research Conference 16–19 June 2003. Nairobi, Kenya.
- Jaetzold R. and Schmidt H. 1983. *Farm Management Handbook of Kenya. Vol. II/C : Natural conditions and farm management information*. Ministry of Agriculture/GTZ, Nairobi, Kenya.

- Jensen J.R., Bernhard R.H., Hansen S., McDonagh J., Möberg J.P., Nielsen N.E. and Nordbo E. 2003. Productivity in maize based cropping systems under various soil–water–nutrient management strategies in semi-arid alfisol environment in East Africa. *Agricultural Water Management* 59: 217–237.
- Kamoni P.T., Mburu M.W. and Gachene C.K.K. 2003. Influence of irrigation and nitrogen fertiliser on maize growth, nitrogen uptake and yield in semi-arid Kenyan environment. *E. Afr. Agric. For. J.* 69(2): 99–118.
- Keating B.A., Siambi M.N. and Wafula B.M. 1992. The impact of climatic variability on cropping research in semi–arid Kenya between 1955 and 1985. In: Probert. M.E. (Ed.) *A search for strategies for Sustainable dryland Cropping in semi-arid Eastern Kenya. ACIAR Proceedings*. 41: 16–25.
- Kihanda F.M., Warren G.P. and Atwal S.S. 2004. The influence of goat manure application on crop yield and soil nitrates variations in semi-arid eastern Kenya. In : Bationo (Ed.). *Managing Nutrient Cycles to Sustain Soil Fertility in Sub-Saharan Africa*. Academy of Sciences Publishers in association with the Tropical Soil Biology and Fertility Institute of CIAT: pp. 173–186.
- Kipserem L.K. 1996. Water harvesting on entric Fluvisols of Njemps Flats of Baringo district. A paper presented at the Dryland applied Research and Extension Project (DAREP) workshop at Embu from 4–6 June, 1996.
- Lal R. 1995. Tillage systems in the tropics. Management options and sustainability implications. *FAO Soils Bulletin* No. 71. FAO Rome.
- Liniger H.P. 1990. Agroecology and water conservation for rainfed farming in the semi-arid footzone west and northwest of Mount Kenya: consequences on water resources and soil productivity. *Geographica-Bernensia. African Studies Series Switzerland. Monographs v. A8*, pp. 95–105.
- McCown R.L. and Jones R.K. 1992. Agriculture of semi-arid areas of eastern Kenya: problems and possibilities. In: Probert. M.E. (Ed.) *A search for strategies for Sustainable dryland Cropping in semi-arid Eastern Kenya. ACIAR Proceedings* 41: 8–14.
- Mellis D. 1996. Water harvesting and conservation tillage: Exploring and adapting with farmers in semi-arid Kenya. A Paper presented at the DAREP soil and water harvesting/conservation tillage workshop 4–6 June 1996. Embu, Kenya.
- Miriti J.M., Odera M.M., Kimani S.K., Kihumba J.N., Esilaba A.O. and Ngae G. N. 2003. On-Farm demonstrations to determine farmers' subjective preference for technology-specific attributes in tied-ridges: Preliminary results. A Paper presented at the 1st KARI Adaptive Research Conference 16–19 June 2003. Nairobi, Kenya.
- Njihia C.M. 1977. The effect of tied ridges, stover mulch and farmyard manure on rainfall abstraction in a medium potential area, Katumani, Kenya. Paper presented at the International Conference on role of soil physical properties, Dec 1977. International Institute. of Tropical Agriculture (IITA). Ibadan, Nigeria.
- Okalebo J.R., Gathua K.W. and Woome P.L. 2002. Laboratory methods of soil and plant analysis: A working Manual. 2nd Edn. TSBF-CIAT and sacred Africa, Nairobi Kenya.
- Omiti J.M., Freeman H.A., Kaguongo W. and Bett C. 1999. Soil fertility maintenance in Eastern Kenya: Current practices, constraints and opportunities. CARMASAK working paper No. 1. KARI/ICRISAT, Nairobi, Kenya.
- Probert M.E., Okalebo J.R., Simpson J.R. and Jones R.K. 1992. The role of boma manure for improving soil fertility. In: Probert. M.E. (Ed.) *A search for strategies for Sustainable dryland Cropping in semi-arid Eastern Kenya. ACIAR Proceedings*. 41: 63–70.
- Rockström J. 2003. Water for food and nature in drought-prone tropics: Vapour shift in rainfed agriculture. *Phil. Trans. R. Soc. Lond. B.* 358(1440): 1997–2009.

Economic evaluation of local inputs in Meru South District, Kenya

Monicah Mucheru-Muna¹, Daniel Mugendi¹, Jayne Mugwe², and James Kung'u¹

¹*Kenyatta University, Department of Environmental Sciences. P.O. Box 43844, Nairobi, Kenya;* ²*Kenya Forestry Research Institute, P.O. Box 20412, Nairobi, Kenya*

Abstract

Declining land productivity is a major problem facing smallholder farmers in Kenya today. This decline is as a result of reduced soil fertility caused by continuous cultivation without adequate addition of manures and fertilizers. Low soil fertility is one of the greatest challenges facing farmers in the central highlands of Kenya. A farmers' participatory trial was established in Meru South District, Kenya in 2000 to investigate feasible soil nutrient replenishment technologies for poor resource smallholder farmers. Results across seven seasons indicate that sole tithonia gave the highest grain yield followed closely by tithonia with half recommended rate of inorganic fertilizer with 6.4 and 6.3 Mg ha⁻¹ respectively. The control treatment gave the lowest yield of 2.2 Mg ha⁻¹ across the seasons. The integration of organic and inorganic nutrient sources of N gave higher maize grain yield as compared to the sole organic materials in all seven seasons. Economic analyses indicate that on average tithonia with half the recommended rate of inorganic fertilizer recorded the highest net benefit (US\$ 787.2) whereas the control treatment gave the lowest benefit (US\$ 271.7). On the other hand the recommended rate of inorganic fertilizer gave the highest (US\$ 12.5) return to labour while sole tithonia gave the lowest (US\$ 4.0). On average in the farmers' fields, manure alone gave the highest return to labour of US\$ 3.6, while the control treatment gave the lowest return to labour US\$ -0.2.

Key words: cost benefit ratio, economic analysis, integrated soil fertility management

Introduction

Decline in soil fertility is a major problem contributing to the low maize grain (staple food) yield in Kenyan smallholder farms. This is especially a problem in the densely populated highlands of central Kenya with over 700 persons km⁻² (Government of Kenya, 2001). The soils in this area are Humic Nitisols with moderate to high inherent fertility (Jaetzold and Schmidt, 1983). However, the soil fertility has declined over time with an annual net nitrogen depletion exceeding 30 kg N (Smaling, 1993) as a result of continuous cropping with insufficient nutrient replenishment. The use of inorganic fertilizers is generally less than 20 kg N ha⁻¹ (Adiel, 2004), which does not meet the optimal crop nutritional requirement. Crop yield decline has thus,

continued to be a major problem facing smallholder farmers in the area. Maize grain yields of small-scale farmers in the densely populated areas is low, usually less than 1.5 Mg ha⁻¹ (Wokabi, 1994) whereas the potential yield is 7–12 Mg ha⁻¹.

Surveys carried out in the area indicate that farmers are aware of the declining soil fertility (as expressed by declining crop yields), but in most cases they do not have readily available resources to replenish the soil fertility (Adiel, 2004). A multidisciplinary farmers participatory trial was therefore established in the main maize growing areas of Meru South District, Kenya in 2000 with the main objective of bringing closer feasible soil nutrient replenishment technologies to the smallholder resource poor farmers.

Materials and methods

Study site

The study was conducted in Meru South District, Kenya, which is located in upper midlands 2 and 3 (UM2 and UM3) at an altitude of approximately 1500 m above sea level. Annual mean temperatures are 20°C and rainfall varies from 1200 to 1500 mm per annum (Jaetzold and Schmidt, 1983). The rainfall is bimodal; the long rains (LR) lasting from March through June and short rains (SR) from October through December. The soils are Humic Nitisols (Jaetzold and Schmidt, 1983), which are deep, well weathered with a moderate to high inherent soil fertility.

Experimental design and management

The off-station experiment was established in the 2000 long rainy season on a farm with poor soils and laid out as a randomized complete block design (RCBD). Plot sizes measuring 6 m x 4.5 m replicated thrice. The test crop, maize, (*Zea mays* L, var. H513 – maize variety commonly grown by farmers in the area) was planted at a spacing of 0.75 m and 0.5 m inter- and intra-row, respectively. Nine soil fertility amendment inputs were applied every season to give an equivalent of 60 kg N ha⁻¹ [which is the recommended rate of N to meet maize nutrient requirement for an optimum crop production in the area (FURP, 1987)]. The tenth treatment was the control with no inputs. The organic materials (biomass transfer) were harvested, chopped and incorporated into the soil to a depth of 15 cm during land preparation in all seasons. Compound fertilizer (23:23:0) was the source of inorganic N and was applied at sowing. Weeding was done twice in each season. At maturity, maize was harvested and the fresh weight of both grain and stover taken. The maize grain was then air-dried and the weight taken. Maize grain yields were expressed on a 12.5% water content.

Farmers' field days were held at the grain filling stage during each season where the farmers toured the experimental plots. Technologies used were described and farmers evaluated the various technologies and exchanged views. They were then requested to select the technologies they wanted to take to their farms. Eventually, from the 2001/2002 SR, farmers started trying out some of the promising technologies in their own farms. The trials established in

the farmers' fields were farmer-designed and farmer-managed. The farmers applied the organic inputs as explained during the field days though some of them adapted the technologies to fit their socio-economic status.

Economic analysis

The economic analysis in this study was done without considering soil nutrients dynamics and the resultant maize yields due to long-term application of inorganic and organic inputs. The local market prices of the various inputs were used in the analysis. However, since the organic amendments had no market prices in the area they were costed in terms of the labour involved in harvesting and incorporation (Table 1).

For the demonstration site, it was assumed that the organic resources were collected within the homestead, thus only the labour for collection, transport and application were taken into account and it was estimated to be 2.9 US\$ 100 kg⁻¹ on dry matter basis (Nziguheba et al., 2002). The labour was valued at the local wage of 0.13 US\$ per hour. The application of the fertilizer was estimated to take an extra 7% of the total labour cost required for maize planting (Jama et al., 1997). Harvested yields in each treatment were reduced by 10% to adjust to realistic values if the experiment was to be managed by the farmer (CIMMYT, 1988).

For the farmers' economic data, time taken to undertake the various activities was indicated (by 6 farmers) and the hours taken costed in terms of US\$ per hour. The benefits refer to the gains obtained by selling the harvested maize grain and stover in the area. Monetary values were converted to US Dollars (US\$) at the exchange rate of 76 Ksh = 1 US\$ (February, 2004).

Table 1. Parameters used to calculate the economic returns for the different nutrient replenishment technologies

Parameter	Actual values
Price of NPK (23:23:0)	1.38 US\$ kg ⁻¹ N
Labour cost	0.13 US\$ hr ⁻¹
Labour cost for planting maize	10.5 US\$ ha ⁻¹
Labour for applying fertilizer	0.74 US\$ ha ⁻¹
Labour for application of organic inputs	2.9 US\$ 100 kg ⁻¹ DM
Price of maize	0.146 US\$ kg ⁻¹
Price of stover	0.012 US\$ kg ⁻¹

DM = dry matter basis. Exchange rate 76 Ksh = 1 US\$ (Feb, 2004).

Data analysis

Data were analysed using Genstat to compare treatment effects on maize yields. Means were separated using Least Significant Difference at 5% level ($P=0.05$).

Results and discussions*Maize grain yield*

Average maize grain yields for different treatments across the seven seasons are presented in Table 2. The results across the seven seasons indicate that, sole tithonia gave the highest grain yield followed closely by tithonia with half recommended rate of inorganic fertilizer with 6.4 and 6.3 Mg ha⁻¹ respectively. Control treatment gave the lowest yield of 2.2 Mg ha⁻¹ across the seasons. The maize grain yields were significantly different ($P<0.05$) between treatments in the seven seasons.

The integration of organic and inorganic nutrient sources of N gave higher maize grain yields compared to the sole application of organic materials during the seven seasons of the study. These results concur with results by Gachengo (1996), Mugendi et al. (1999), and Mutuo et al. (2000) on the combination of organic and inorganic nutrient inputs. Such combination can be considered as a better option for increasing fertilizer use efficiency and providing a

more balanced supply of nutrients (Vanlauwe et al., 2002). Kapkiyai et al. (1998) reported that combination of organic and inorganic nutrient sources resulted into synergy and improved synchronization of nutrient release and uptake by plants leading to higher yields.

Lower maize grain yield in 2000 and 2001 long rains seasons could be associated with the low and unevenly distributed rainfall. Precipitation in the 2000 long rains season averaged 126 mm and most of it was recorded within the first three weeks of the season. In 2001, 431 mm was recorded during the long rains with 86% of the rains falling in the first two weeks of the season. The low and the poorly distributed rainfall could have reduced the availability of nutrients to the maize plants. Soil moisture content influences N mineralization and availability and subsequent maize growth and N uptake (Soon et al., 2001).

Economic analysis

The results of the economic analysis indicate that, on average across the seven seasons, tithonia with half recommended rate of inorganic fertilizer treatment recorded the highest net benefit with US\$ 787.2 while the control treatment recorded the lowest with US\$ 271.7 (Table 3). Leucaena recorded the highest BCR (7.0) while manure with half recommended rate of inorganic fertilizer and tithonia with half recommended rate

Table 2. Maize yields (Mg ha⁻¹) under different technologies from 2000 to 2003 in Chuka, Meru South District, Kenya

Treatment	Seasons							Mean
	Grain weight (Mg ha ⁻¹)							
	2000 LR	2000/2001 SR	2001 LR	2001/2002 SR	2002 LR	2002/2003 SR	2003 LR	
1	1.2	6.7	3.7	4.6	4.2	6.1	5.0	5.3
2	1.2	6.5	4.9	2.9	5.9	5.0	6.5	5.5
3	1.2	6.6	4.3	6.5	5.4	7.0	7.4	6.4
4	0.7	6.0	2.8	4.5	4.5	7.6	6.5	5.4
5	1.0	6.1	4.0	5.8	4.7	6.3	6.4	5.7
6	1.3	6.8	5.4	5.6	5.4	6.2	7.2	6.3
7	1.1	5.8	4.3	5.1	4.3	7.2	6.2	5.7
8	1.3	6.1	3.7	4.4	5.0	7.2	6.2	5.7
9	1.4	6.3	5.0	3.2	4.3	5.8	5.5	5.3
10	0.6	2.6	1.2	1.5	1.8	2.6	2.8	2.2
LSD	0.2	0.2	0.4	0.4	0.3	0.4	0.5	0.3

Treatment (1 = manure; 2 = manure + ½ fert; 3 = tithonia; 4 = calliandra; 5 = leucaena; 6 = tithonia + ½ fert; 7 = calliandra + ½ fert; 8 = leucaena + ½ fert; 9 = rec fert; 10 = control).

Table 3. Net benefit, Benefit-Cost Ratio (BCR) and return to labour (US\$) from 2000 to 2003 in Chuka, Meru South District, Kenya

Treatment	Net benefit	BCR	Return to labour
Cattle manure	645.0	5.0	5.0
Cattle manure + 30 kg N ha ⁻¹	616.3	3.5	6.8
Tithonia	784.2	4.0	4.0
Calliandra	652.5	5.8	5.9
Leucaena	779.7	7.0	7.0
Tithonia + 30 kg N ha ⁻¹	787.2	3.5	6.3
Calliandra + 30 kg N ha ⁻¹	747.3	4.4	9.0
Leucaena + 30 kg N ha ⁻¹	572.4	4.3	6.9
60 kg N ha ⁻¹	666.3	3.6	12.5
Control	271.7	5.2	5.2
LSD	80.2	2.0	2.4

Table 4. Return to labour for 6 farmers (3 men & 3 women) at Chuka during the 2003 long rains season

Farmer	Technologies							
	1	2	3	4	5	6	7	8
Njeri Gitari (F, 45 yrs)	—	7.2	1.9	5.3	2.3	1.9	—	0.3
Kaari Mbuba (F, 45 yrs)	—	0.7	2.7	1.3	1.2	0.7	3.7	-1.1
Mercy Micheni (F, 45 yrs)	5.0	3.6	—	2.8	—	—	7.1	—
Martin Ikingi (M, 35 yrs)	4.5	4.0	—	2.7	—	—	2.7	—
Kanga Muga (M, 74 yrs)	—	2.1	1.6	3.5	0.5	3.8	-0.2	0.4
Bedford Ntobori (M, 65 yrs)	1.2	0.9	—	0.9	—	—	-0.05	-0.25

Technologies (1 = manure; 2 = manure + ½ fert; 3 = tithonia; 4 = tithonia + ½ fert; 5 = calliandra + ½ fert; 6 = leucaena + ½ fert; 7 = rec fert; 8 = control).

of inorganic fertilizer recorded the lowest (3.5). On the other hand recommended rate of inorganic fertilizer gave the highest (US\$ 12.5) return to labour while sole tithonia gave the lowest (US\$ 4.0).

On average across the seven seasons the treatments with sole application of organics recorded a higher BCR compared to the treatments with integrations of organic and inorganic nutrients. On the other hand, treatments with sole organics recorded lower return to labour compared to the treatments with integration of organic and inorganic nutrients. The higher return to labour in the integrations could be due to the low labour required compared to the sole applications. Despite the fact that tithonia had the lowest return to labour in the demonstration site (Table 3), most farmers in the study area were willing and eager to try it in their farms. This could be most probably due to the low opportunity cost of their time as also observed by Mutuo et al. (2000) with some farmers in their study in Western Kenya.

The results of farmers' economic analysis show that the return to labour for each technology varied

largely between farmers during the 2003 long rains season (Table 4). Return to labour of inorganic fertilizer ranged between 0.4 and 8.2. This variation could be as a result of different working speeds of the farmers and also due to the inherent soil fertility in their farms. In general, women recorded a higher return to labour compared to the men this is because the men rated their labour higher than the women. However, the age of farmers did not seem to influence the return to labour.

On average, manure with half recommended rate of inorganic fertilizer gave the highest net benefit while control gave the lowest with US\$ 938.8 and 63.3 respectively (Table 5). On the other hand sole manure gave the highest BCR and return to labour with 2.9 and 3.6 respectively, while control gave the lowest BCR and return to labour with 0.6 and -0.2 respectively.

Though studies by Jama et al. (1997) and Mutuo et al. (2000) indicated that organics have high labour costs, the results in the farmers' fields indicate that all of

Table 5. Net benefit, Benefit-cost ratio (BCR) and return to labour (US\$) for six farmers during the 2003 long rains season in Chuka, Meru South District, Kenya

Treat	Net Benefit	BCR	Return to labour
1	542	2.9	3.6
2	938.8	2.5	3.1
3	304.3	1.8	2.1
4	795	2.2	2.8
5	337.4	1.2	1.3
6	462	1.8	2.1
7	360	1.3	2.7
8	63.3	0.6	-0.2
LSD	677	2.0	2.5

Treat = Treatment (1 = manure; 2 = manure + ½ fert; 3 = tithonia; 4 = tithonia + ½ fert; 5 = calliandra + ½ fert; 6 = leucaena + ½ fert; 7 = rec fert; 8 = control).

them (except calliandra with half recommended rate of inorganic fertilizer) recorded a return to labour greater than 2.0, the minimum acceptable for most smallholder farming activities.

Some of the organic materials like calliandra and leucaena could be more economically attractive when used as a protein supplement for dairy cattle (ICRAF, 1993; Reynolds and Jabbar, 1994; Jama et al., 1997) and the manure returned back to the farm.

Conclusions

After four years of continuous cultivation and application of organic and inorganic inputs, the maize yields have continued to improve. Sole tithonia and tithonia with half recommended rate of inorganic fertilizer technologies gave reasonable yields over the seven seasons and most farmers are trying them in their farms. During the seven seasons, tithonia with half recommended rate of inorganic fertilizer recorded the highest net benefit while control recorded the lowest. On the other hand recommended rate of inorganic fertilizer gave the highest return to labour while sole tithonia gave the lowest. Since the organic materials may not be available in large amounts that are required for sole application, farmers are encouraged to adopt the integration of the organic and the inorganic as they have higher maize grain yields, net benefits and returns to labour.

Acknowledgements

The authors wish to thank the Rockefeller Foundation and TSBF-AfNet for providing financial support for the field experimentation. They also appreciate the contribution and collaborative efforts by the Kenya Agricultural Research Institute (KARI), Kenya Forestry Research Institute (KEFRI) and Kenyatta University (Department of Environmental Sciences) in administering field activities. Lastly, the cooperation and contributions by researchers and Kirege community members (farmers and administration) are acknowledged.

References

- Adiel R.K. 2004. Assessment of on-farm adoption potential of nutrient management strategies in Chuka division, Meru south, Kenya. Msc Thesis, Kenyatta University, Kenya.
- CIMMYT 1988. From agronomic data to farmer recommendation: An economic training manual. CIMMYT, Mexico.
- Fertilizer Use Recommendation Project (FURP) 1987. Description of first priority trial site in the various Districts. Final Report. Vol. 24. Embu District. National Agricultural Research Laboratories, Nairobi, Kenya.
- Gachengo C. 1996. Phosphorus release and availability on addition of organic materials to Phosphorus fixing soils. MPhil thesis, Moi University, Eldoret, Kenya.
- Government of Kenya 2001. The 1999 Kenya National Census results. Ministry of Home Affairs, Nairobi, Kenya.
- International Centre for Research in Agroforestry (ICRAF), 1993. Annual report for 1992. Nairobi, Kenya.
- Jaetzold R. and Schmidt H. 1983. Farm management handbook of Kenya. Natural conditions and farm information. Vol. 11/ C. East Kenya. Ministry of Agriculture, Kenya.
- Jama, B., Swinkles, R.A., and Buresh, R.J., 1997. Agronomic and economic evaluation of organic and inorganic sources of phosphorus for maize. *Agron. J.* 89: 597–604.
- Kapkiyai J.J., Karanja N.K., Woome P. and Qureshi J.N. 1998. Soil organic carbon fractions in a long-term experiment and the potential for their use as a diagnostic assays in highland farming systems of central Kenya. *African Crop Science Journal* 6: 19–28.
- Mugendi, D.N., Nair, P.K.R., Mugwe, J.N., O'Neill, M.K., and Woome, P.L., 1999. Calliandra and Leucaena alley cropped with maize. Part 1: Soil fertility changes and maize production in the sub-humid highlands of Kenya. *Agrof. Syst.*, 46: 39–50.
- Mutuo P.K., Mukalama J.P. and Agunda J. 2000. On-farm testing of organic and inorganic phosphorous source on maize in Western Kenya. In: *The Biology and Fertility of Tropical Soils: TSBF Report*, pp 22.
- Nziguheba G., Merckx R., Palm C.A. and Mutuo P. 2002. Combining Tithonia diversifolia and fertilizers for maize production in a phosphorus deficient soil in Kenya. *Agrof. Syst.* 55: 165–174.
- Reynolds L. and Jabbar M. 1994. The role of alley farming in African livestock production. *Outlook Agric.* 23:105–113.

- Smaling E. 1993. Soil Nutrient Depletion in sub-Saharan Africa. In: Van Reuler H. and Prins W. (Eds.), The role of plant nutrients for sustainable food crop production in sub-Saharan Africa. VKP, Leidschendam, The Netherlands.
- Soon Y.K., Clayton G.W. and Rice W.A. 2001. Tillage and previous crop effects on Dynamics of Nitrogen in a wheat-soil system. *Agron. J.* 93: 842–849.
- Vanlauwe B., Diels J., Aihou K., Iwuafor E.N.O., Lyasse O., Sanginga N. and Merckx R., 2002. Direct interactions between N fertilizer and Organic matter: Evidence from trials with ¹⁵N-labelled fertilizer. In: Vanlauwe B., Diels J., Sanginga N., and Merckx R. (Eds.) *Integrated Plant nutrient Management in Sub-Saharan Africa: From concept to practice.* CAB International Wallingford, Oxon, UK.
- Wokabi S.M. 1994. Quantified land evaluation for maize yield gap analysis at three sites in the Eastern slopes of Mt. Kenya. International Institute for Aerospace Survey and Earth Science (ITC) The Netherlands.

Effect of Rock Phosphate, Lime and Green Manure on Growth and Yield of Maize in a Non Productive Niche of a Rhodic Ferralsol in Farmer's Fields

Tabu I.M.^{1*}, Bationo A.², Obura R.K.¹ and Masinde J.K.¹

¹ Department of Crops, Horticulture and Crop Sciences, Egerton University, P.O Box 536 20115, Egerton, Kenya;

² Tropical Soil Biology and Fertility institute of CIAT Box 30677, Nairobi, Kenya; ³ Department of Soil Science, Egerton University, P.O. Box 536, Njoro, Kenya, Email address: immtabu@yahoo.com; * Corresponding author

Abstract

Ferralsol and *Acrisol* soil types important for maize production in Western Kenya have low pH, phosphorus (P) and organic matter plus high levels of Al and Fe oxides that fix P. Minjingu rock phosphate (MRP), lime and green manure (*Tithonia*) that are cheap and locally available are recommended for use. The low solubility of MRP when directly applied and unavailability of adequate organic materials limits their use. An experiment was carried out in farmers' field to determine the interactive effect of combining MRP and *Tithonia* or lime in a degraded patch of *Ferralsol* soil in Western Kenya. The treatments; \pm MRP, \pm lime, \pm *Tithonia*, +Triple superphosphate (TSP) and their combinations were applied to maize in (4 × 5) m² plots. The field layout was in a completely randomized block design replicated four times. Plant height (eight weeks after emergence) and leaf number showed a significant interactive effect between: TSP × *Tithonia* ($P \leq 0.0001$), TSP × Lime ($P \leq 0.001$), MRP × *Tithonia* ($P \leq 0.05$), *Tithonia* × TSP × Lime ($P \leq 0.005$). Leaf area index (m² leaf m⁻²) was similarly was significantly affected by TSP ($P \leq 0.0001$), lime ($P \leq 0.05$), lime × TSP ($P \leq 0.0002$) and TSP × *Tithonia* ($P \leq 0.0001$) and lime × *Tithonia* × TSP ($P \leq 0.05$). The significant treatments also affected were similarly observed in grain yield (t/ha) as TSP (2.5 t/ha), MRP (1.0 t/ha), lime × TSP (2.5 t/ha), TSP × *Tithonia* (2.9 t ha⁻¹), *Tithonia* × TSP × lime (2.4). Hence combining TSP or MRP with *Tithonia* may be used to alleviate multiple problems in the degraded patches of *Ferralsols*

Key words: Ferralsols, lime, Maize yield, Rock phosphate, *Tithonia diversifolia*

Introduction

Only about 20% of Kenya is medium to high potential agricultural land. Intensified production is required if enough food to sustain the population of 30 million people (GoK, 2001) is to be achieved. Although tremendous work has been made to increase food production through plant breeding, decline in soil fertility resulting from continuous cultivation greatly undermines these efforts (Kapkiyai et al., 1999). Using a nutrient balance model, Smaling et al. (1993) estimated nutrient mining of about 42 kg N ha⁻¹, 3 kg P ha⁻¹ and 29 kg K ha⁻¹ from the soil. Further, Sanchez and Leakey (1999) observed that nitrogen and

phosphorus were the most limiting nutrients in Western Kenya.

In a survey to establish causes for the yield gap, Hassan et al. (1998) found that farmers realized sub-optimal yields (less than 1 ton ha⁻¹ compared to a potential of 8 ton/ha) because of the inherently infertile soils and inability to use recommended fertilizer rates. Intrinsic variations in soil fertility where some parts of the farm are productive while others are non-productive reduce the adoption of blanket fertilizer recommendation. Studies in Kenya (Woomer et al., 1998; Tabu, 2003) and West Africa (Gandah et al., 2003; Woortman et al., 2003; Brouwer and Bouma, 1997) have documented existence of variations in soil fertility

within farmers' fields. The non-productive soil fertility niches in the high potential areas of Kenya are characterized by low available nutrients, low soil pH, P and soil organic matter (Murage et al., 2000; Tabu, 2003). In addition, to the sub optimal management level, the parent material and management contribute immensely to the formation of non-productive niches (de Jager et al., 2001). The non-productive patches need to be identified and managed appropriately if the quest for sustainable food production is to be realized.

While farmers and scientists are able to identify these non-productive patches, management options are less developed because of the multiple constraints that require a combination of solutions. Phosphorus deficiency resulting from the inherently low P, nutrient mining and low soil pH is the main problem in these non-productive soil patches. Traditionally, conventional water-soluble P fertilizers have been developed to curb mining and supplement the indigenous sources. These fertilizer types are however expensive and inefficient in acidic soils where the high Al and Fe oxides fix P making it unavailable to the crop. Farmers adapt to the low soil fertility and lack of capital by concentrating farmyard manure (FYM) and other organic materials into productive patches and growing adapted crops like cassava and sweet potatoes or leaving the infertile niches fallow (Murage et al., 2000; Gandah et al., 2003). Inadequate transport and limited amounts of household wastes and farmyard manure negate their use in the non-productive niches that are usually located far away from homesteads. Since the high population delimits fallowing (the traditional practice of regenerating soil fertility), alternative strategies have to be sought to achieve high sustainable crop yields. The agronomic challenge under the heterogeneous soil conditions is to maintain high productivity in the fertile niches while rehabilitating the non-productive ones.

Site-specific soil fertility management, which aims at enhancing resource use efficiency while protecting the environment, is advocated for use in the heterogeneous conditions (Smaling and Braun, 1996). Woomer et al. (2003) even developed fertilizer formulations targeting specifically the non-productive soil fertility niches within farmers' fields. Integrated nutrient management narrowly defined as combined use of organic and inorganic inputs is a priority concern among small-scale farmers (Palm et al., 1997). A management strategy where conventional inorganic fertilizers are used in productive niches while the locally alternative organic and inorganic fertilizers are used in the non-productive niches is suggested. The rationale for this

strategy is to target the decline in soil fertility problem using a mixture of strategies i.e. improves nutrient use efficiency and crop yield while protecting the environment.

Minjingu rock phosphate (MRP) a natural ore has long been identified as a potential source of P in acidic soils. However MPR has low water solubility that result in low agronomic effectiveness. This low agronomic effectiveness can be improved through partial acidulation, blending and composting. These methods are however costly for small-scale farmers. Naturally occurring low molecular weight organic acids from plant residues can improve dissolution of MPR and this mechanism provides new perspective (Vanlauwe et al., 2000). Biomass transfer has also been identified as potential for improving soil fertility among the small-scale farmers' fields. In a survey of organic resources at the farm, Kwabiah et al. (2003) found that a lot of biomass existed at the hedges of many farms but were rarely used as fertilizers. A mixture of organic materials important for biomass transfer and composting could be used to rehabilitate non-productive outfields where the transport cost would be low. Nziguheba et al. (1998) has shown that combining locally available high quality organic and inorganic fertilizers enhances P availability to maize. Addition of organic amendments, which on decomposition release organic acids that help in dissolution of PR and reduce adsorption by the Al and Fe oxides, could enhance the effectiveness. Hue (1990) and Nziguheba et al. (1998) showed that addition of organic residues increased P uptake and crop growth. Conventionally, P use efficiency under high acidity conditions is increased by liming. Kanyanjua et al. (2002) however found that the lime requirements in Central Kenya are high and not easily available. Mixing organic and inorganic resources can enhance P use through formation of anions, which compete for adsorption sites hence reducing P sorption and providing liming effect (Alloush, 2003; Nziguheba et al., 1998). Most studies have however been carried out in the laboratory and involved high levels of organic materials which may not be feasible at farm level. The challenge therefore is how to use these effects as management tools and as apart of the integrated nutrient management systems. A study was carried out to identify and document variation in soil fertility and determine the effect of using a combination of locally available resources (*Tithonia*, rock phosphate and lime) on the agronomic P use efficiency and maize yield in the non-productive soil fertility niches of farmers' fields.

Materials and methods

Site description

The study was conducted in Kabras Division, in Western Kenya (longitudes 34° 52' and 15°E, latitude 00° 26' and 00° 52'N, altitude of 1300 to 1900 metres above sea level). The area has a population density of 700 persons/km². The site receives bimodal rainfall of about 2000 mm per annum and means minimum and maximum temperatures of 8°C and 25°C respectively. Soils are highly weathered clay loams classified as *Ferralsols* and *Acrisols* (FAO, 1998). Farmers are mainly small-holders with between 0.5 and 3 ha of land per household on which they keep livestock and grow subsistence crops such as maize, beans and bananas.

Participatory mapping of soil fertility management niches

To determine spatial variation in soil fertility, Shitirira village located on a *Rhodic Ferralsol* soils was purposively selected, physically identified and delineated on the ground based on interviews with local leaders and agricultural staff. Based on surface and profile pit characteristics, the soil was classified using guidelines according to FAO (1977) and FAO (1998) soil classification systems. Participatory soil mapping according to Defoer et al. (1996) was used to elicit soil fertility management niches. A transect line was established within the village following brief walks at farms where the soil fertility management niches were noted. At home,

members of the household drew a map to show the different soil fertility management niches.

Top soil samples (0–20 cm) were taken randomly from five points and then bulked to form composite samples representing soil fertility management niches. A sub-sample of the soil from each niche was identified, air-dried, ground to pass through a 2-mm sieve and analyzed for soil texture, pH and available nutrients. All the soil analyses were done at the Department of Soil Science Laboratories, Egerton University. Soil texture was determined by the hydrometer method and soil pH by in soil: water extraction ratio of 1:2.5. Total organic carbon (C) was determined by Walkley-Black wet oxidation using a solution of potassium dichromate and concentrated Sulphuric, and total nitrogen (N) by semi micro-Kjedhal digestion, P by colorimetric analysis and K by flame spectrophotometry (Okalebo et al., 1993). Calcium and Mg were however determined by atomic absorption spectrophotometry (Okalebo et al., 1993). Exchangeable acidity (Hp) was determined on soils with pH less than 5.5 as described by Anderson and Ingram (1993).

A randomized complete block design experiment with 12 treatments (Table 1) was established in the non-productive soil fertility management niche. Lime and MPR was broadcasted and later incorporated into the soil while *Tithonia diversifolia* (*Tithonia*) was chopped into pieces and manually incorporated into the top 20 cm of soil before planting. Hybrid maize (H614) was then planted in plots of 4 m × 5 m at a spacing of 75 cm × 25 cm. Nitrogen was applied at a blanket rate of the 75 kg N per ha as recommended by KARI (1995). One third of the N was applied at planting while the rest was applied as topdress eight weeks after emergence.

Table 1. Treatment composition

Treatment code	Description
1	Control (no nutrients added to the soil)
2	Lime (Magmax at rate of 4 tons ha ⁻¹)
3	Minjingu Rock phosphate (60 kg P ha ⁻¹)
4	Triple super phosphate (60 kg P ha ⁻¹)
5	<i>Tithonia diversifolia</i> dry weight (15 kg P ha ⁻¹)*
6	Lime (Magmax 4 ton ha ⁻¹) + Rock phosphate (60 kg P ha ⁻¹)
7	Lime (Magmax 4 ton ha ⁻¹) + Triple super phosphate (60 kg P ha ⁻¹)
8	Lime (Magmax 4 ton ha ⁻¹) + <i>Tithonia diversifolia</i> (15 kg P ha ⁻¹)
9	Rock phosphate 45 kg P ha ⁻¹ + <i>Tithonia diversifolia</i> (15 kg P ha ⁻¹)
10	Triple super phosphate (45 kg P ha ⁻¹) + <i>Tithonia diversifolia</i> (15 kg P ha ⁻¹)
11	Lime (Magmax 4 ton ha ⁻¹) + Rock phosphate (45 kg P ha ⁻¹) + <i>Tithonia diversifolia</i> (15 kg P ha ⁻¹)
12	Triple super phosphate (45 kg P ha ⁻¹) + <i>Tithonia diversifolia</i> (15 kg P ha ⁻¹) + Lime (Magmax 4 ton ha ⁻¹)

Jama et al (2000) found that *Tithonia* supplies 3.5% N, 0.37% P and 4.1% K. In *Tithonia* treatments, the N amount supplied by the green manure was taken into account before applying Calcium ammonium nitrate.

Results and discussion

i) Distribution of on-farm soil fertility management niches

Analysis of on-farm maps showed a variety of soil fertility niches (productive and non-productive niches) attributable to management and inherent agro-ecological conditions. The most productive niches included homesteads, old kraals (Oboma), old hutsites, home-gardens (HG), outfields (Ofmm) and valley bottomlands (VB) and occurred in 96%, 29%, 25%, 100%, 100% and 75% of the farms respectively. The variation in soil fertility resulted mainly from differential accumulation of organic inputs. Home gardens resulted from manuring of areas near the homestead with household wastes and poultry manure. Unlike the conventional home gardens that are associated with multi-storey systems, the HG in Kabras are based mainly on high value annual crops (Lok, 2001). When farmers relocated homesteads, they used their former habitation areas (old hutsites) for priority crops (vegetables and maize). Old kraal sites resulted from in-situ management of cattle. During the day, farmers tethered cattle on their farms or allowed them to roam, and at night, they kept them in enclosures (kraals) near homesteads. At night, over 50% of the farmers kept cattle in kraals while 30% tethered them within the homesteads. Manure from kraals was piled in heaps for composting before being transported to the crop fields. After about two to three years, the kraals usually became 'muddy' resulting in their relocation. The former kraal

sites were then used for maize and vegetable production. Valley bottomlands are fertile probably because of the alluvial deposits and the high soil moisture. Murram soils and eroded sites in the outfields that resulted from unbalanced exploitation of nutrients (depletion through biogenic or physical processes) were the least productive soil fertility niches.

ii) Soil chemical characteristics of on-farm niches

The soil type in Shitirira village is a *Rhodic Ferralsol* with low pH, low P, organic matter and other available nutrients (Groenenboom and Drift, 1991; Braun et al., 1997; Tabu, 2003). The farmer's management practices led to variations in chemical soil properties. Generally, cultivation led to a decline in soil pH, organic carbon, Ca, Mg and K (Table 2). The productive soil fertility management niches (home gardens, old kraal sites and valley bottomlands) had the higher pH, P, organic carbon, Ca and Mg compared to outfields implying that management of the outfields should be multiple pronged i.e. tailored towards alleviation of low soil organic matter, pH and available nutrients.

iii) Growth and yield of maize

Lime is generally used to ameliorate the soil fertility by increasing pH and reducing aluminium and manganese phytotoxicity. Compared to the control, application of lime alone increased the plant height by 80% hence showing that the low growth of maize was associated with acidity effects (Table 3). The amelioration effect could have resulted from increased pH via supply of Ca and Mg to the soil and relief of the maize from Al phytotoxicity (He et al., 1996). In a pot experiment, Kanyanjua et al. (2002) similarly found that application of lime on maize led to increase in dry matter.

Table 2. Physical and chemical properties of the soils in different farmer perceived soil fertility niches

Niche type	Sand	Clay	Silt	pH	P	K	Ca	Mg	Ex. acidity	N	Carbon
	g kg ⁻¹			mg kg ⁻¹			Cmolc		g kg ⁻¹		
Hg/Oboma	230 ^a	549 ^a	213 ^a	5.41 ^a	2.91 ^a	1.09 ^a	1.61 ^a	2.68 ^a	0.95 ^a	0.08 ^a	2.27 ^a
Npasture	270 ^a	476 ^b	250 ^a	5.50 ^a	2.55 ^a	1.28 ^a	1.79 ^a	2.40 ^a	0.76 ^a	0.08 ^a	2.15 ^a
Vbottom	320 ^a	439 ^{bc}	234 ^a	5.11 ^a	3.43 ^a	0.59 ^b	1.41 ^a	2.14 ^a	1.77 ^a	0.15 ^b	2.40 ^a
Forest	260 ^a	544 ^{abd}	193 ^a	5.35 ^a	2.61 ^a	0.84 ^b	3.74 ^b	5.00 ^b	1.20 ^a	0.21 ^b	4.97 ^c
Ofmm	260 ^a	520 ^{ab}	260 ^c	3.99 ^b	2.51 ^a	0.65 ^b	1.31 ^a	2.01 ^a	1.54 ^a	0.07 ^a	1.90 ^b

* Numbers followed by the same letter in a column are not significantly different.

Table 3. Effect of phosphatic fertilizer type and lime on growth of maize *

Treatment	Height (cm)	Leaf number	Leaf area indexm ² leaf m ⁻²
1	18.10 ^c	6.20 ^c	0.14 ^d
2	32.50 ^{bc}	6.40 ^c	0.35 ^{cd}
3	24.50 ^c	6.75 ^c	0.27 ^d
4	62.71 ^a	8.29 ^a	0.71 ^b
5	33.25 ^{bc}	6.75 ^c	0.30 ^d
6	19.00 ^c	6.50 ^c	0.13 ^d
7	40.88 ^b	8.00 ^{ab}	0.55 ^{bc}
8	17.88 ^c	6.12 ^c	0.13 ^d
9	33.25 ^{bc}	6.88 ^c	0.31 ^d
10	68.75 ^a	8.75 ^a	1.04 ^a
11	21.75 ^c	6.75 ^c	0.15 ^d
12	32.33 ^{bc}	7.11 ^{bc}	0.37 ^d

* The growth variables were taken 45 days after emergence of the crop. * Numbers followed by the same letter in a column are not significantly different.

There was also significant effect of P fertilizer on the height of maize. Triple superphosphate (TSP) fertilizer had the tallest plants followed by *Tithonia* green manure then Minjingu rock phosphate. Relative to TSP, *Tithonia* and rock phosphate increased plant height by 53% and 39% respectively. The difference in effectiveness could be attributed to the low amount of P in *Tithonia* treatment and the low (6.8%) citrate solubility of P in rock phosphate (Zapata and Roy, 2004). The amount of P supplied by 4 tons of *Tithonia* was small i.e. about 15 kg P ha⁻¹ (Jama et al., 2000). Combining rock phosphate or TSP with *Tithonia* increased the height of maize by 36% and 10% respectively. The expected synergistic effects of lime were not expressed in plant height. Combining lime with MRP or *Tithonia* led to a slight though insignificant decline in plant height probably because rock phosphate dissolution was depressed due to the higher pH caused by lime application. Lime alone or in combination with MRP and *Tithonia* did not significantly affect the number of leaves of maize. Triple superphosphate in combination with *Tithonia* or lime followed by TSP alone had the highest number of leaves. Rock phosphate alone and in combination with, *Tithonia* did not significantly increase the number of leaves compared to the control. In maize and other gramineae, the appearance of leaves is a function of initiation on plant apex and elongation rate (Plenet' et al., 2000). The significant fertilizer effect on plant height implies P deficiency influenced negatively the elongation rate of the plant. Lime significantly increased leaf area index (LAI) by more than 150%. Combination of lime and P fertilizer

however had varying effects. Lime combined with rock phosphate or with *Tithonia* did not have a significant effect on LAI probably because pH amelioration by lime or both lime and *Tithonia* antagonized dissolution of rock phosphate while presence of carbonates in the medium reactive and/or organic acids may have limited the reaction (Kpombekou and Tabatabai, 2003). The results above show that P deficiency led to decline in LAI through reduction in growth rate (plant height) and number of leaves per plant. Plenet et al. (2000) also observed similar results of P deficiency on maize.

Maize grain yield ranged from 0 kg ha⁻¹ to 4000 kg ha⁻¹ (Figure 1). Although the soil pH was low (Table 2) and negatively affected plant growth, application of lime did not significantly increase grain yield probably because time was too short for the reaction to be effected. Uexkull (1986) similarly noted that if high levels of lime were not effectively incorporated they depressed crop yield. Since application of lime led to increase in plant height and LAI, the limited effect on grain yield implies that other factors in addition to pH may have limited the process. Application of lime provided synergistic effect to TSP and *Tithonia*. A slight increase in grain yield when TSP was combined with lime implies that P was more limiting than acidity per se. Application of *Tithonia* together with lime led to a 15 times increase in grain yield. Combining lime with rock phosphate led to a decline in grain yield probably by increasing pH (providing Ca²⁺ which may have reduced the dissolution of rock phosphate). He et al. (1996) similarly found that application of limestone

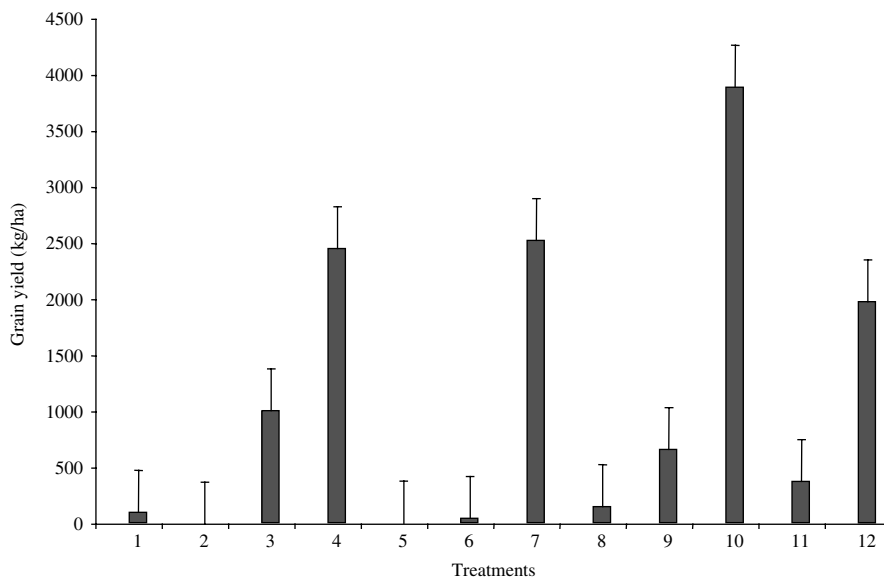

Figure 1. Effect of lime, green manure and phosphorus fertilizer on grain yield (kg ha^{-1}) of maize.

significantly inhibits rock phosphate dissolution, which they attributed to increase in pH and exchangeable Ca. Irrespective of source, application of P resulted in significant increase in grain yield. The results confirmed the general understanding that *Rhodic Ferralsols* were limited by P. Variation in grain yield attributed to the source of P was however significant. Triple super phosphate combined with *Tithonia* had the highest grain yield followed TSP, rock phosphate, rock phosphate plus *Tithonia* and lastly *Tithonia* alone. The green manure (*Tithonia*) alone had the lowest yield probably because of limited amount of P available i.e. 15 kg P ha^{-1} compared to 60 kg ha^{-1} in other treatments. Although Gachengo et al. (1999) and Kwabiah et al. (2003) using a rate of 5 ton/ha reported that *Tithonia* could be equated to TSP, Nziguheba et al. (2002) observed that when moderate to low levels of *Tithonia* are used, suboptimal grain yield was realized. Combining TSP and *Tithonia* however increased the grain yield by about 59%. The synergistic effect of combining TSP and *Tithonia* could be attributed to enhance levels of labile P, decreased adsorption of P and enhanced Ca (Nziguheba et al., 1998; Alloush 2003). An increase in total number of ears per hectare was evident when lime was combined with TSP. Application of lime alone or in combination with other P sources did not significantly affect the total number of ears per hectare (Table 4). Irrespective of source, P application had a significant

effect on the number of ears. Triple super phosphate had the highest number of ears, followed by Minjingu rock phosphate and lastly green manure. Combining green manure with TSP increased the number of ears by 13% probably because of the synergistic effect of green manure. The effect was however dramatic when *Tithonia* (green manure) was combined with rock phosphate. The effect could be attributed to green manure enhancing the utilization of rock phosphate (Vanlauwe et al., 2000). The effect was however not reflected in overall grain yield, suggesting that something else limited grain filling.

Application of lime per se or its combination with other P sources (save for TSP) did not significantly affect the stover weight. This implies that factors other than pH influenced the biomass. Application of P however significantly increased the maize stover. Triple super phosphate had the highest maize stover while the effect of rock phosphate was similar to that of green manure. Combining TSP or rock phosphate with *Tithonia* did not significantly influence the maize stover.

Application of lime alone depressed the harvest index of maize probably because the high levels used may have interfered with the Ca:Mg:K ratio of the soil. Combining lime with the P fertilizers also had varying effects. Combining lime with rock phosphate led to a decline in harvest index. This was expected because dissolution of rock phosphate is highest at low

Table 4. Effect phosphatic fertilizer type and lime on the yield components of maize

Treatment	Number of ears ha ⁻¹	Stover weight kg ha ⁻¹	100 seed weight (gm)	Harvest index
1	2222 ^g	3222 ^e	5.08 ^{cde}	0.04 ^{de}
2	0 ^g	2778 ^e	0.00 ^e	0.00 ^e
3	16889 ^g	6133 ^{bc}	16.97 ^{abcd}	0.18 ^{bc}
4	35000 ^{ab}	10444 ^a	23.72 ^{ab}	0.23 ^{ab}
5	556 ^g	4333 ^{bc}	4.58 ^{cde}	0.003 ^e
6	1481 ^g	3185 ^e	10.19 ^{cde}	0.01 ^e
7	31111 ^{bc}	10278 ^a	17.68 ^{abc}	0.25 ^{ab}
8	2222 ^g	3889 ^{bc}	4.11 ^{de}	0.04 ^{de}
9	13333 ^{ef}	5556 ^{bc}	10.46 ^{cde}	0.12 ^{cd}
10	394444 ^a	12222 ^a	27.44 ^a	0.30 ^a
11	6667 ^{fg}	4778 ^{bc}	13.72 ^{bcd}	0.09 ^{cde}
12	23889 ^{cd}	6833 ^b	24.64 ^{ab}	0.27 ^{ab}

* Numbers followed by the same letter in a column are not significantly different.

pH. A combination of lime and *Tithonia* led to a significantly higher harvest index probably because the former enhanced the use of P from the later. Combining lime and TSP did not however have a significant effect probably because TSP already supply high available P. Application of P significantly increased the harvest index. Triple super phosphate had the highest harvest index followed by rock phosphate and lastly green manure. As expected, combining TSP with *Tithonia* resulted in higher harvest index.

Application of lime did not significantly influence the 100-seed weight. TSP had the highest 100-seed weight followed by rock phosphate and lastly *Tithonia*. This implies that the amount of P was important in determining the 100 seed weight. Combination of TSP and *Tithonia* enhanced 100 seed weight.

Conclusion

Soil acidity and P deficiency significantly limits the growth and yield of maize in the non-productive soil fertility niches of the farmers fields. Application of lime can ameliorate soil acidity effects of these niches. Locally available P sources (rock phosphate and *Tithonia*) can be used to rehabilitate the non-productive niches and should be used in combination with other resource in order to utilize the full advantages. Care should however be taken because lime and *Tithonia* can increase soil pH hence reduce the dissolution of rock phosphate.

Acknowledgement

We thank Eliud Barasa for assistance during the field experiments and DANIDA and AfNet for funding the project.

References

- Alloush G.A. 2003. Dissolution and effectiveness of phosphate rock in acidic soil amended with cattle manure. *Plant and Soil* 251:37–46.
- Anderson J.M. and Ingram J.S. 1993. *Tropical Soil Biology and Fertility. A handbook of methods.* CAB International, Wallingford, UK.
- Braun A.R., Smaling E.M.A., Muchugu E.I., Shepherd K.D. and Corbett J.D. 1997. Maintenance and improvement of soil productivity in Highlands of Ethiopia, Kenya, Madagascar and Uganda. An inventory of spatial and non-spatial surveys and research data on natural resources and land productivity (African Highlands Initiative Technical Report No. 6). International Centre for Research in Agroforestry, Nairobi, Kenya.
- Brouwer J. and Bouma J. 1997. Soil and crop growth variability in the Sahel: Highlights of research (1990-1995) at ICRISAT Sahelian center. Information bulletin No. 49. Icrisat, Andhra Pradesh, India.
- de Jager A., Onduru, M. van Wijk S., Vlaming, J. and Gachini G.N. 2001. Assessing sustainability of low-external -input farm management systems with the nutrient monitoring approach: a case study in Kenya. *Agric Syst.* 69: 99–108.
- Defoer T., Kante D.T., Hilhorst T. and Groote H.O. 1996. Towards more sustainable soil fertility management. ODI-AgREN Network paper No.63.
- FAO 1998. World Reference Base for Soil resources. World Soil Resources Report No. 84. FAO Rome, Italy.
- FAO 1977. Guidelines for soil profile Descriptions. Food and Agriculture organization of United Nations Rome.

- Gachengo C.N., Palm C.A., Jama B. and Othieno C. 1999. *Tithonia* and Senna green manure and inorganic fertilizers as phosphorus sources for maize in W. Kenya. *Agroforestry Syst.* 44: 21–36.
- Gandah M., Bouma J. Brouwer J. Hiernaux P. and van Duivenbooden N. 2003. Strategies to optimize allocation of limited nutrients to sandy soils of the Sahel: a case study from Niger, West Africa. *Agric Ecos. and Envir.* 94: 311–319.
- Government of Kenya (GoK). Ministry of Finance and Planning (2001). The 1999 population and housing census: Counting our people for development Vol. 1 Ministry of Finance and Planning, Nairobi.
- Groenboom M. and Drift M. 1991. Soil survey in Western Kenya. A semi-detailed soil survey and qualitative land evaluation for South Kabras location (Kakamega district). University of Utrecht, Faculty of Geographical Sciences Utrecht, Belgium.
- Hassan R.M., Muriithi F. and Kamau G. 1998. Determinants of fertilizer use and the gap between farmers maize yields and potential yields in Kenya pp. 137–168. In: Hassan R.M. (Ed) *Maize technology development and transfer- A GIS application for research planning in Kenya.*: CAB International, Wallingford, UK.
- He Z.L., Baligar V.C., Martens D.C., Ritchey K.D. and Kemper W.D. 1996. Factors affecting phosphate Rock dissolution in acid soil amended with liming materials and cellulose. *Soil Sci. Soc Am. J* 60: 1596–1601
- Hue N.V. 1990. Interactions of Ca(H₂PO₄)₂ applied to an Oxisol and previous sludge amendment: soil and crop response. *Commun. Soil Sci. Plant. Anal.* 21: 61–73.
- Jama B., Palm C.A., Buresh R.J., Niang A.I., Gachengo C. and Nziguheba G. 2000. *Tithonia* as a green manure for soil fertility improvement in Western Kenya: A review. *Agrofor. Syst.* 49: 201–221.
- Kanyanjua S.M., Ileri L., Wambua S and Nandwa S.M. 2002. Acidic soils in Kenya: constraints and remedial options. KARI technical Note No. 11 of June 2002.
- Kapkiyai J.J., Karanja N.K., Quresh J.N., Smithson P.C. and Woomer P.L. 1999. Soil organic matter and nutrient dynamics in a Kenyan Nitisol under long-term fertilizer and organic input management. *Soil Biol and Biochem.* 31:1773–1782.
- KARI (Kenya Agricultural research Institute), 1995. Kenya Agricultural Research Institute. New fertilizer recommendations for small-scale farmers in Kenya. Information Bulletin No. 12.
- Kpombekou-A. and Tabatabai M.A. 2003. Effects of low molecular weight organic acids on phosphorous release and phytoavailability of phosphorus in phosphate rocks added to soils. *Agric. Ecosys. and Environ* 100(2/3): 275–284.
- Kwabiah A.B., Stoskopf N.C, Palm C.A. and Voroney R.P 2003. Soil P availability as affected by the chemical composition of plant materials: implications for P-limiting agriculture in tropical Africa. *Agric Eco. and Env.* 100: 53–61.
- Lok R. (2001). A better understanding of traditional homegardens through the use of locally defined management zones. *Indigenous Knowledge Development Monitor* 9: 14–19.
- Murage, E.W., Karanja N.K., Smithson P.C. and Woomer P.L 2000. Diagnostic indicators of soil quality in productive and non-productive smallholder fields of Kenya's Central highlands. *Agric. Ecosys. and Environ.* 79: 1–8.
- Nziguheba G., Merckx R., Palm C.A. and Muto P. 2002. Combining *Tithonia diversifolia* and fertilizer for maize production in a phosphorus deficient soil in Kenya. *Agrofor. Syst.* 55(3): 165–174.
- Nziguheba G., Palm C.A., Buresh R.J. and Smithson P.C. 1998. Soil phosphorus fractions and adsorption as affected by organic and inorganic sources. *Plant and Soil* 198: 159–168.
- Okalebo J.R., Gathua K.W. and Woomer P.L. 1993. Laboratory methods of soil and plant analysis. A working manual. *Tropical Soil Biology and Fertility (TSBF)*, EPZ Printer, Nairobi Kenya.
- Palm C.A., Myers R.J.K. and Nandwa S.M. 1997. Combined use of organic and inorganic Nutrient sources for soil fertility maintenance. In: *Replenishing Soil fertility in Africa*. SSSA Special publication No. 51.
- Plenet' D. Mollier A. and Pellerin S. 2000. Growth analysis of maize field crops under phosphorus deficiency: II. Radiation-use efficiency biomass accumulation and yield component. *Plant and Soil* 224: 259–272.
- Sanchez P.A. and Leakey R.R. 1999. Land use transformation in Africa: Three determinants for balancing food security with Natural resource utilization. *Euro. J. of Agron* 7: 1–9.
- Smaling, E.M.A., Stoorvogel J. and Windmeijer P 1993. Calculating soil balances in Africa at different scales: II-District scale Fertilizer Research 35: 237–250.
- Smaling E.M.A. and Braun A. 1996. Soil fertility research in sub-Saharan Africa: new dimensions new challenges. *Comm. Soil Sc. Plant Analy* 27: 365–386.
- Tabu. I.M. 2003. Soil fertility niches, farmer perception and maize yield: A case for improved crop yield in Kabras Division of Western Kenya. Doctor of Philosophy Thesis. Department of Agronomy, Egerton University, Njoro, Kenya.
- Uexkull H.R. von 1986. Efficient fertilizer use in acid upland soil of the humid tropics. *FAO Fertilizer and Plant nutrition Bulletin* 10.
- Vanlauwe B., Diels J., Sanginga N., Carsky R.J., Deckers J. and Merckx R. 2000. Utilization of rock phosphate by crops on a crop representative toposequence in a Northern Guinea Savanna zone of Nigeria: response by maize to previous herbaceous legume cropping and rock phosphate treatments. *Soil Biol. and Bioch.* 32: 2079–2090.
- Woomer P.L., Okalebo J.R., Maritim H.K., Obura P.A., Mwaura F.M., Nekesa P. and Mukhwana E.J. 2003. PREP-PAC: a nutrient replenishment product designed for smallholder s in Western Kenya. *Agric Ecos. and Envir* 100: 295–303.
- Woomer P.L., Bekunda M.A., Karanja N.K., Moorehouse T. and Okalebo J.R 1998. Agricultural resource management by smallholder farmers in East Africa. *Nature and resources* 34 (4): 22–33.
- Wortman R.L., Brouwer J., Albersen P.J. 2003. Characterization of spatial soil variability and its effect on millet yield on Sudano-Sahelian cover sands in S.W. Niger. *Geoderma* (In press).
- Zapata F. and Roy R.N. 2004. Use of phosphate rocks for sustainable Agriculture. In *FAO Fertilizers and Plant Nutrition Bulletin* 13. FAO Rome, Italy.

Changes in Soil Organic Matter as Influenced by Organic Residue Management Regimes in Selected Experiments in Kenya

Waswa B.S.^{1,2}, Mugendi D.N.¹, Vanlauwe B.² and Kung'u J.¹

¹*Environmental Studies, Kenyatta University, P. O. Box 43844, Nairobi, Kenya;* ²*Tropical Soil Biology and Fertility Institute of CIAT (TSBF-CIAT), P. O. Box 30677, Nairobi, Kenya;* *Corresponding author: bwswa@cgiar.org

Abstract

The failure to understand the dynamics of soil organic matter (SOM) is a major limitation to the sustainability of smallholder production systems that predominantly relied on organic resources for the maintenance of soil fertility. This study evaluated the influence of organic resource management on SOM in three selected experiments in central and western highlands of Kenya. Results showed that soil carbon (C), nitrogen (N) and carbon-13 (¹³C) values in the three experiments were depending on the amounts of the organic residues applied as well as the duration of application indicating that organic residue management practices have a profound impact on the final contribution to the SOM pools. Kabete experiment had the narrowest C, N and ¹³C values pointing to its young age as well as the low quantity of the organic residues applied. On the other hand, Embu experiment had soil C values above the critical level of 2.0% indicating a positive effect of continued application of organic residues. In all the three sites, aggregate mineral fraction (MF) size distribution were dominated by macroaggregates (250–500 μm and >500 μm) which on average accounted for about 72%, 65% and 69% of the dry soil weight for Maseno, Kabete and Embu experiments, respectively. Similarly higher proportions of aggregate light fractions (LF) C and N were observed in macroaggregate fractions for the three experiments with organic treatments having higher proportions. The ¹³C signatures of the LF in the macroaggregates (>250 μm) were more negative as compared to the ¹³C values in the microaggregate (53–250 μm) LF suggesting a more C contribution from C3 vegetation to the most recently incorporated SOM pool

Key words: Soil organic matter, organic resources, fractionation

Introduction

Soil organic matter (SOM) plays an important role in mitigating major constraints to crop production as well as essential environmental services and hence its decline with cropping is of concern (Vanlauwe, 2004). Studies indicate that soil physical, chemical and biological properties can sustainably be improved through the improvement of SOM (Woomer et al., 1994; Buyanovzky et al., 1994; Parton et al., 1989). Practices such as alley cropping and biomass transfer offer the potential of improving SOM through the cycling of organic matter back to the soil. The major

obstacle hindering the efficacy of these strategies is the lack of adequate understanding of the effects of the different organic resource qualities on the nature of the resultant SOM. Soil organic carbon analyses carried out on whole soil (WS) samples do not give a clear impression of the status of the soil since this is obscured by the high background carbon levels (Blair et al., 1995). This therefore calls for the need to explore the SOM fractions. Considering that information on the active pools of the SOM is still scanty, it is difficult to optimize decisions on the use of the qualities of SOM that contribute to higher nutrient recovery. This study therefore sought to increase understanding of the

effects of organic resources on the nature of the SOM formed and to identify the roles played by the various components of SOM in nutrient supply as well as other soil properties.

Materials and methods

This study was conducted in three experimental sites run by Tropical Soil Biology and Fertility Institute of CIAT (TSBF-CIAT) and Kenya Agricultural Research Institute (KARI):

- 1) **Kabete experiment** is located in Central Kenya at the National Agriculture Research Laboratory (NARL) which lies at 36° 46' E and 01° 15' S and an altitude of 1650 m (Kimetu, 2002). The site is located in the semi-humid climatic zone with a total bimodal rainfall of over 970 mm per annum. The soils are derived from quartz trachyte geological material, and are typical Humic Nitosols inherently fertile, with moderate amounts of organic carbon, Ca, Mg, K but low in available P, clay 40%, sand 23% and silt 37%. The experiment was established in 1999 and involved seasonal application of *Tithonia diversifolia*, *Calliandra calothyrsus*, and *Senna spectabilis* at the rates of 1.3, 1.8 and 1.9 t ha⁻¹ respectively.
- 2) **Maseno experiment**, located on Msinde Farm in western Kenya was established in 1995 as a Randomized Complete Block Design (RCBD) with four replicates (Nziguheba et al., 2000). The site is located at an altitude of 1420 m, a latitude of 0° 06' N and a longitude of 34° 34' E. The mean annual rainfall is 1800 mm distributed between two rainy seasons: the long rainy season from March to August and the short rainy season from September to January. The soil is a nitosol (FAO, 1990) with 42% clay, 25% silt and 33% sand. Msinde farm

had been under mixed native vegetation involving grasses and shrubs. The experiment involved application of *Calliandra calothyrsus*, *Tithonia diversifolia* and *Senna spectabilis* organic resources at the rate of 5 t ha⁻¹ for 6 consecutive seasons (Short rains 1995 – Long rains 1999) after which the experiment had been under residual phase.

- 3) **Embu experiment** is situated in eastern Kenya, Central highlands at the Embu Regional Research Centre in Eastern Kenya (Mugendi et al., 1999). The centre lies at 0° 30' S, 37° 30' E and an altitude of 1480 m. The soils are mainly Typic Palehumult (Humic Nitosols according to FAO-UNESCO) derived from basic volcanic rocks. The soils are deep, well weathered with friable clay texture and moderate to high inherent fertility. The site has clay, silt and sand contents of 38%, 30% and 32%, respectively. Total annual average rainfall ranges between 1200 mm and 1500 mm received in two distinct rainy seasons: the long rain (LR) from mid March to June and the short rains (SR) from October to December. The average monthly maximum temperature is 25° C and the minimum 14° C. The experiment was established in 1992 and involved application of *Calliandra calothyrsus* and *Leucaena leucocephala* organic resources at the rate of about 2.3 t ha⁻¹.

The choice of these three experiments was based on the different rates of organic resources applied, the experiment lifespan as well as their unique ecological locations that characterize most smallholder farming areas in Kenya.

Table 1 presents the quality parameters of the organic resources applied in Kabete, Maseno and Embu experiments. *Calliandra*, with the highest polyphenol content,

Table 1. Chemical properties for the organic materials used in Kabete, Maseno and Embu experiment

Experiment	Organic Resource	% N	% P	% PP	% Lignin
Kabete	<i>Tithonia</i>	4.35	0.45	2.2	7.25
	<i>Senna</i>	3.4	0.15	2.6	10.8
	<i>Calliandra</i>	2.7	0.1	7.65	15.95
Maseno	<i>Tithonia</i>	3.66	0.28	3.71	12.0
	<i>Senna</i>	3.61	0.23	2.17	13.2
	<i>Calliandra</i>	3.5	0.16	7.91	12.1
Embu	<i>Calliandra</i>	3.95	—	11.75	11.6
	<i>Leucaena</i>	3.95	—	3.3	6.85

PP – Polyphenol, P – Phosphorus, N – Nitrogen (Source: Mugendi et al., 1999a; Kimetu, 2002 and Nziguheba, 2001).

was considered as of lower quality compared to the other organic resources. Senna was intermediate while tithonia and leucaena were of the highest quality due to their high nitrogen contents but relatively lower lignin and polyphenol contents. Preliminary carbon-13 (^{13}C) values on the organic resources showed senna to have a delta ^{13}C of -24.17% , calliandra -21.62% and tithonia -22.40% .

Soil sampling and analysis

Soil samples were collected from the selected experiments before the onset of the long rains (LR) 2002. Soil was collected from the 0–10 cm layer, as this is where most impact of added organic matter is felt. A proportion of the soil samples was finely ground (pulverized) using a pestle and mortar and analyzed for total carbon (C), nitrogen (N) and carbon 13 (^{13}C) on an automated nitrogen and carbon (ANCA) mass spectrometer (Diels et al., 2001). Carbon isotope composition was expressed in delta-13 (^{13}C) units using the international Pee De Belemnite (PDB) reference standard:

$$\delta^{13}\text{C}\text{‰} = [^{13}\text{R}_{\text{sample}} - 1] \times 1000^{13}\text{R}_{\text{standard}}$$

Where: $^{13}\text{R} = \frac{^{13}\text{C}}{^{12}\text{C}}$

SOM fractionation was done following a modification to the method of Six et al. (2000). Soil fractionation was done on a sample of 100 g dry weight. Prior to fractionation the soil was capillary wetted overnight for 18 hours at 4°C . The soil was then sieved through a series of four sieves (500 μm , 250 μm , 53 μm and 20 μm). To ensure minimal aggregate disruption the sample was submerged in water on top of each successive sieve and the aggregates separated by moving the sieve in a bucket of water up and down 3 cm for about 2 minutes. After the washing the stable aggregates were then washed into a moisture beaker. As observed by Sollins et al. (1984) studies of SOM require distinguishing mineral-associated from free particulate organic matter. Most free SOM is usually undecomposed debris that floats on heavy liquids and is referred to as light fraction (LF). As such LF from each aggregate class was separated by gently swirling the aggregates to suspend and decanting any material floating on water. Silt and clay were separated at room temperature (25°C) following the sedimentation process. Silt and clay were isolated from the $<20\ \mu\text{m}$ aggregate fraction following the aliquot method. In brief, the total soil plus

water passing through the 20 μm sieve was weighed, thoroughly mixed and a subsample (1:5) collected for subsequent sedimentation cycle. The subsample collected was placed in a 1 litre-measuring cylinder and made to the mark with water. The aliquot was then mixed by tumble inverting the cylinder 20 times and left to settle for 2 h 10 min. The top 20 cm fraction was then siphoned from the top. This represented the clay fraction (0–5 μm). Material that settled after this time is considered to be silt (5–20 μm). The siphoning process was repeated (at least 4 times) until the water in the cylinder became clear, an indication that the entire clay fraction had been removed. The two fractions were then flocculated using hydrochloric acid (HCl) dried and weighed prior to C and N analysis. The aggregates plus the LF were then oven dried at between 55° and 60°C , weighed and analysed for C, N and ^{13}C .

Whole soil and SOM fractions C, N and ^{13}C were analyzed using an automated carbon, nitrogen mass spectrometer (ANC analyzer) and the eventual proportions expressed on soil weight basis. Data was subjected to analysis of variance (ANOVA) and means separated at $P \leq 5\%$.

Results

Whole soil total carbon, nitrogen and carbon-13 in Kabete, Maseno and Embu experiments

Kabete experiment had the narrowest contents of C, N and carbon-13 contents compared to Maseno and Embu experiments (Table 2). This could be attributed to the short period of organic residue application in Kabete experiment compared to the other experiments. Despite this, all treatments receiving organic residues had higher C and N content compared to fertilizer and the control treatments. Soil carbon-13 signature for the whole soil (WS) from Kabete was not significantly different and indicated a delta ^{13}C signature closer to that of C4 vegetation. Values ranged from -11.92% to -12.18% (Table 2). These signatures tended to be closer to the C4 ^{13}C signature of maize residues of about -12.00% (Schwartz et al., 1986). This indicates that despite the application of the C3 organic resources (calliandra, senna and tithonia) in this experiment, a minimal shift in the WS carbon-13 had occurred. Reasons for the narrow ranges of C, N and ^{13}C in Kabete may be the rapid mineralization of the organic residues due to increased aeration as a result of tillage, higher soil temperatures leading to

Table 2. Whole soil total carbon, nitrogen and carbon-13 of Kabete, Embu and Maseno experiments as at March 2002

Experiment	Treatment	% C	%N	¹³ C (PDB)
Kabete	Control	1.81	0.14	-11.92
	Fertilizer	1.78	0.14	-11.96
	Tithonia	1.84	0.14	-12.18
	Senna	1.86	0.14	-11.95
	Calliandra	1.81	0.14	-12.15
	SED	0.044	0.002	0.275
Embu	Control	2.35	0.19	-15.65
	Fertilizer	2.47	0.20	-16.07
	Calliandra	2.48	0.21	-16.69
	Leucaena	2.52	0.21	-16.32
	SED	0.132	0.009	0.250
Maseno	Control	1.59	0.14	-17.46
	Tithonia	1.80	0.15	-17.82
	Calliandra	1.83	0.16	-18.09
	Senna	1.86	0.16	-18.10
	SED	0.047	0.004	0.173

higher decomposition rates, smaller quantities of litter inputs and the shorter duration of organic residue application in this experiment (Nandwa, 2001). The delta carbon-13 ($\delta^{13}\text{C}$) of SOM is comparable to that of the source plant material (Schwartz et al., 1986) and thus every change in vegetation between C3 and C4 plants or the application of organic residues to the soil as organic manure result in a corresponding change in the $\delta^{13}\text{C}$ value of the SOM (Lefroy et al., 1995). As observed by Paustian et al. (2000) gains in soil C can be enhanced if proper management is maintained and that increases in soil C stocks require increasing C inputs and/or reducing soil heterotrophic respiration.

Total C values for Embu treatments were higher than the recommended critical value for soil carbon of 2.0% (Table 2) for Kenya as reported by FURP (1987). Such a favourable SOC content in Embu experiment could be attributed to the continued application of the organic resources to the soil. Leucaena treatment had soil C content of 2.52% while calliandra, fertilizer and the control had C content of 2.48%, 2.47% and 2.35% respectively. Higher soil carbon content in the calliandra treatment could be due to the low decomposition as explained by its higher polyphenol and lignin contents (Palm and Sanchez, 1990; Mafongoya et al., 1998). Soil total N in Embu treatments was significantly different and was of the order leucaena = calliandra = fertilizer > control. As with the soil carbon, continued mineralization of leucaena and calliandra organic residues may have resulted in the build up of soil organic matter N pool. Whole soil carbon-13 values were significantly

different for the treatments in Embu experiment. This was as a result of the less negative $\delta^{13}\text{C}$ signature observed in the control (-15.65‰) treatment as compared to the highest $\delta^{13}\text{C}$ of -16.07‰ observed in the calliandra treatment. The great shift observed in the ^{13}C signature between the treatments receiving organic residues and the control indicate a greater contribution to the soil C from the continued application of the leucaena and calliandra residues. This study did not consider the contribution to the ^{13}C signatures of weeds. As observed by Ong et al. (1996), C4-weeds tend to lose their competitive advantage in terms of higher light-use efficiency at light saturation as shading by a growing maize crop increases. Weeds can significantly result in an input of carbon-13 into the cropping system Diels et al. (2001).

Whole soil (WS) total carbon for Maseno experiment was significantly different ($P \leq 0.05$) among the treatments (Table 2) and was of the order senna = calliandra = tithonia > control. Senna treatment recorded WS C content of 1.86%, calliandra 1.83%, tithonia 1.80%, while the control recorded WSC content of 1.59%. The high C contents in senna and calliandra treatments compared to the tithonia treatment could be attributed to the lower quality of these two organic resources, which results in lower rates of mineralization leading to C build-up. As with C, total N across the treatments was significantly different ($P = 0.05$) and was highest in all treatments receiving organic resources compared to the control treatment (Table 2). This indicates that application of organic

resources can help increase the soil N contents. Further lower quality organic resources such as calliandra and senna will result in larger build up of soil N pools as compared to high quality resources such as tithonia (Gachengo et al., 1999). Carbon-13 signature for Maseno was more negative compared to Embu and Kabete experiments indicating a greater shift in the type of soil C towards a C3 signature contributed by the application of C3 organic materials (senna, tithonia and calliandra). Further, the greater C3 labelling observed here could be due to the larger quantities of the organic residues applied (5 t dry matter per season) and the stabilization of the decomposing organic residues applied in Maseno experiment.

Soil organic matter fractionation

Aggregate mineral fraction

Aggregate MF proportions for Maseno were not significantly different for aggregate classes >500 µm, 20–53 µm, silt and clay classes (Table 3). For the 250–500 µm fraction, calliandra had the highest aggregate MF proportion (21.10%) followed by tithonia (19.69%) then the control (17.58%). In Kabete experiment, significant differences in aggregate MF was observed in the silt fraction, where aggregate MF proportions were in the order tithonia > calliandra = control (Table 3). There was no significant difference among the treatments in Embu experiment across all aggregate size classes (Table 3). This may be explained by the relatively high

and uniform soil carbon contents in both the organic and the control treatments.

Despite the above observations, there were higher proportions of macroaggregates across the three sites. Large proportions of macroaggregates imply an elevated soil C concentrations resulting from the binding effects from fungal mycelia (Elliott, 1986). The well defined aggregate proportion in Maseno experiment could be attributed to improved SOM resulting from the large application of organic residues (OR). Kabete soils indicated a substantial decrease in small macroaggregates (250–500 µm) concomitant with an increase in microaggregate MF. As observed by Six et al. (2000) and Paustian et al. (1997), increasing cultivation intensity could lead to a loss in macroaggregates and an increase in microaggregates, silt and clay contents.

Proportions of aggregate free light fraction

Higher aggregate light fractions (LF) were observed in macroaggregate fractions of Maseno experiment with calliandra treatment having the highest proportions followed by tithonia and the control (Table 4). There was significant difference in the >500 µm fraction where the proportion of the LF in the calliandra treatment was 0.059 g/100 g soil while that of tithonia and the control were 0.050 and 0.036 g/100 g soil respectively. Higher LF in calliandra treatment could be attributed to slow decomposition which results in the persistence of calliandra residues in the soil. There was a generally higher microaggregate LF

Table 3. Proportion of aggregate mineral fraction for Kabete, Embu and Maseno experiments

	>500 µm	250–500 µm	53–250 µm	20–53 µm	Silt	Clay
Kabete Experiment						
Calliandra	32.72	20.53	23.40	4.70	2.74	1.29
Control	35.29	18.58	21.98	4.22	2.68	1.08
Tithonia	29.32	19.99	26.29	5.23	3.36	1.50
SED	4.06	1.088	2.85	0.448	0.206	0.1577
Embu Experiment						
Calliandra	32.82	23.59	24.62	2.61	1.54	0.68
Control	34.95	22.14	24.21	2.42	1.46	0.59
Leucaena	37.17	21.72	22.78	2.32	1.43	0.62
SED	3.810	1.578	3.210	0.508	0.269	0.0964
Maseno Experiment						
Calliandra	28.38	21.10	15.13	2.70	1.55	0.82
Control	31.27	17.58	12.97	2.32	1.17	0.59
Tithonia	28.99	19.69	14.87	2.59	1.48	0.73
SED	2.123	0.518	0.77	0.264	0.1263	0.1051

Table 4. Proportion of aggregate light fraction for Kabete, Embu and Maseno experiments

Treatment	>500 μm	250–500 μm	53–250 μm
Kabete Experiment			
Calliandra	0.08	0.05	0.06
Control	0.07	0.03	0.05
Tithonia	0.052	0.04	0.07
SED	0.015	0.008	0.013
Embu Experiment			
Calliandra	0.29	0.08	0.11
Control	0.16	0.05	0.07
Leucaena	0.19	0.06	0.07
SED	0.054	0.009	0.029
Maseno Experiment			
Calliandra	0.06	0.04	0.04
Control	0.04	0.03	0.04
Tithonia	0.05	0.03	0.04
SED	0.005	0.004	0.005

compared to the small macroaggregate (250–500 μm) fractions. This is an indication of increased mineralization of organics from the large macroaggregate LF to the microaggregate fraction. In Kabete, there was no significant difference in the three aggregate LFs although there was a build up in the microaggregate (53–250 μm) LF relative to the small macroaggregate (250–500 μm). LFs were highest in calliandra followed by control and lastly tithonia (Table 4). In Embu experiment, calliandra had the highest LF proportions in the 250–500 μm class with a recorded LF proportion of 0.085 g/100 g soil compared to tithonia with 0.057 and the control with 0.052 g/100 g soil (Table 4).

Of the three experiments, Embu experiment had higher aggregate LF proportions thus indicating the beneficial effects of continued organic residue application in this experiment. Further, the difference in the free light fraction across the sites indicates that the quantity of free light fraction in any soil is mostly affected by differences in residue management regimes (Paustian et al., 1997). As observed by Six et al. (1999) coarse free LF is probably less chemically recalcitrant than the fine free LF (53–250 μm) due to the less advanced stage of decomposition of the coarse free LF. The LF consists of recognizable plant debris with high C:N ratio and low specific weight, and is easily decomposable (Christensen, 1992). Further, the C:N ratio in the LF generally decreases with the decreasing particle size separates indicating an increasing degree of humification. It further implies that this

macro-organic matter is much more susceptible to mineralization, and contributes significantly to the soil available nutrient pool (Tiessen and Stewart, 1983). Decreased LF in Maseno that was under residual at the time of sampling need for continued application of organic residues to sustain the losses in organic matter resulting from increased oxidation as a result of cultivation.

Aggregate mineral fraction carbon and nitrogen in Kabete Experiment

The aggregate MF total organic carbon (TOC) in Kabete was dominant in the macroaggregates compared to the micro-aggregates (Figure 1). TOC averaged 11.12 g kg⁻¹ soil in the macroaggregates soil and 4.93 g kg⁻¹ soil in the microaggregate fractions. Significant differences in the aggregate MF C were only observed in the silt fraction where tithonia recorded a C content of 0.79 g C kg⁻¹ soil followed by the control (0.61 g C kg⁻¹ soil) and calliandra (0.57 g C kg⁻¹ soil). As the case with aggregate C, significant differences in aggregate MF N were only observed in the silt fraction where tithonia recorded aggregate N content of 0.06 g N kg⁻¹ soil followed by the control (0.05 g N kg⁻¹ soil) and calliandra (0.04 g N kg⁻¹ soil) treatment (Figure 2). The bulk of the aggregate MF N was observed in the macroaggregates (>250 μm) in the three treatments. This is an indication that most of the readily available

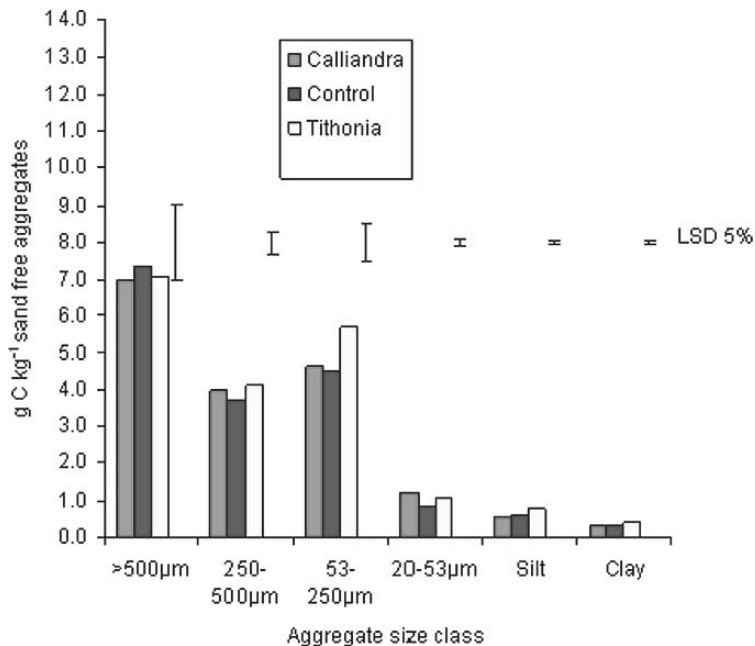

Figure 1. Aggregate mineral fraction carbon for Kabete experiment.

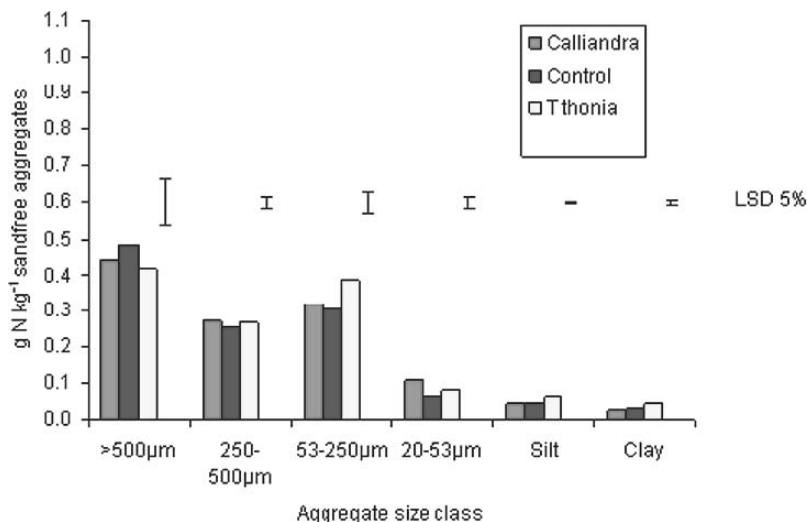

Figure 2. Aggregate mineral fraction nitrogen for Kabete experiment.

SOM-N is stored in the recently incorporated organic residues that have a faster turnover rate. Lower N in the >500 µm fraction for tithonia was compensated by a higher total organic nitrogen (TON) in the 53–250 µm fraction indicating that decomposition of tithonia was faster and tended to shift towards the finer aggregate classes.

Aggregate mineral fraction carbon and nitrogen in Embu Experiment

There were no significant differences in the aggregate MF C and N for the treatments in Embu experiment (Figures 3, 4). However as with the Kabete experiment, most of the aggregate MF C and N was dominant

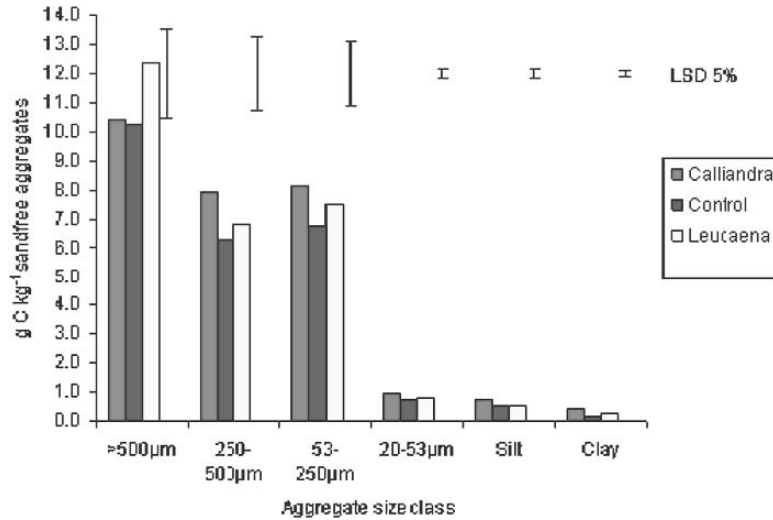

Figure 3. Aggregate mineral fraction carbon for Embu experiment.

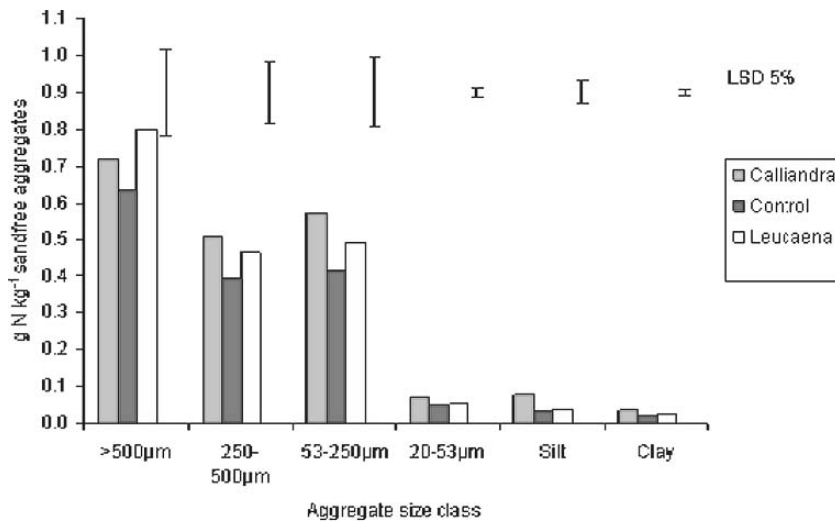

Figure 4. Aggregate mineral fraction nitrogen for Embu experiment.

in the macroaggregates relative to the microaggregate fractions.

Aggregate mineral fraction carbon and nitrogen in Maseno Experiment

Figure 5 indicates aggregate MF carbon for Maseno experiment. There was significant difference in the aggregate MFC of the 250–500 µm, 53–250 µm and silt aggregate size classes. In the 250–500 µm class calliandra recorded the highest C content of 3.97 g C kg⁻¹ soil

and was followed by tithonia (3.73 g C kg⁻¹ soil) then the control (2.99 g C kg⁻¹ soil). A similar trend was observed in the 53–250 µm and the silt where the order was calliandra > tithonia > control. The persistence of the calliandra derived organic residues could be attributed to its higher polyphenol and lignin contents compared to tithonia which has lower polyphenol and lignin contents. There was a general decrease in the amount of carbon across all the aggregate size classes suggesting a stabilization of the SOM with continued mineralization without addition of external organic residues. Soil aggregate nitrogen was more

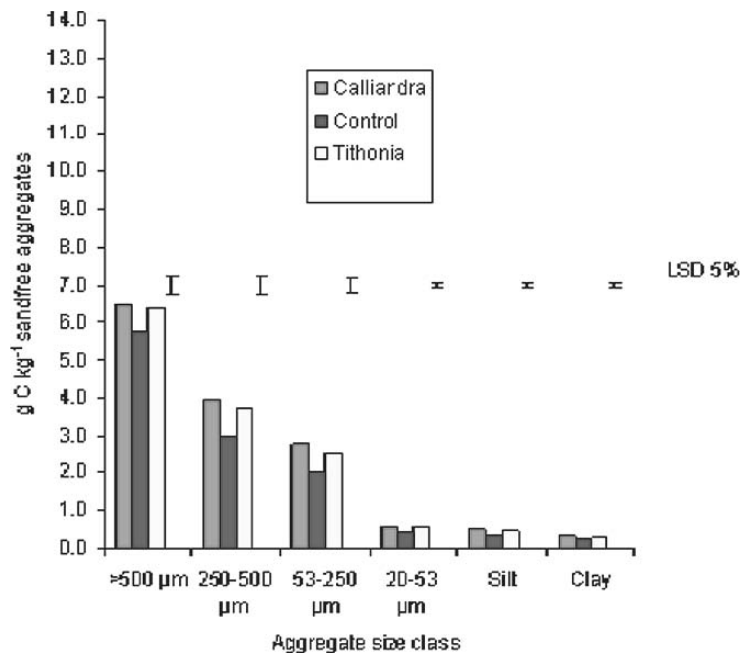

Figure 5. Aggregate mineral fraction carbon for Maseno experiment.

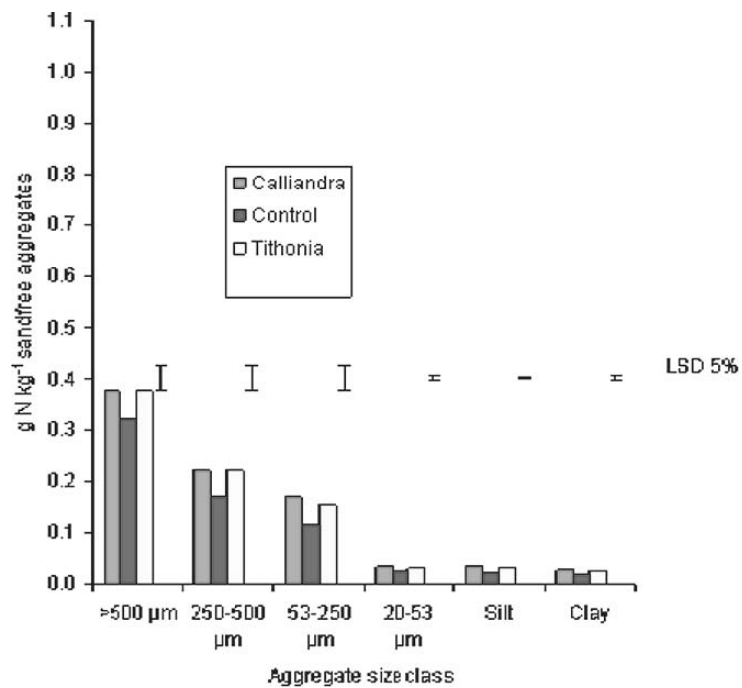

Figure 6. Aggregate mineral fraction nitrogen for Maseno experiment.

Table 5. Aggregate mineral fraction carbon-13 in Kabete, Embu and Maseno experiments

Aggregate class	Calliandra	Control	Tithonia	SED
Kabete Experiment				
>500 μm	-15.90	-14.98	-16.29	1.250
250–500 μm	-14.85	-15.12	-15.42	1.200
53–250 μm	-15.83	-15.42	-15.83	0.753
20–53 μm	-15.55	-15.05	-15.44	1.047
Silt	-15.72	-15.59	-15.85	1.100
Clay	-15.93	-16.98	-17.31	0.744
Embu Experiment				
>500 μm	-19.34	-19.23	-19.68	0.186
250–500 μm	-19.58	-19.13	-19.47	0.246
53–250 μm	-19.26	-19.16	-19.77	0.402
20–53 μm	-19.14	-19.33	-19.64	0.262
Silt	-19.43	-19.43	-19.72	0.252
Clay	-20.96	-21.02	-20.93	0.225
Maseno Experiment				
>500 μm	-20.59	-20.19	-20.59	0.545
250–500 μm	-20.73	-20.47	-20.65	0.441
53–250 μm	-20.78	-20.93	-20.95	0.555
20–53 μm	-20.98	-20.62	-21.04	0.240

defined in Maseno experiment compared to Embu and Kabete experiments (Figure 6). Significant differences in the aggregate MF N were observed in the silt fraction where 0.036, 0.033 and 0.024 g N kg⁻¹ soil for calliandra, tithonia and the control respectively. On average, calliandra had higher aggregate TON followed by tithonia while the control had the least amount of N. As observed in the other experiments, TON tended to dominate in the macroaggregates as compared to the smaller aggregate size classes confirming the theory of hierarchy distribution of SOM.

Aggregate mineral fraction carbon-13 in Kabete, Embu and Maseno Experiments

Despite there being no significant differences in the aggregate MF delta ¹³C in Kabete experiment, the carbon-13 values across the aggregate MF classes tended to be more negative compared to the whole soil $\delta^{13}\text{C}$ values (Table 5). This was an indication that recently incorporated organic residues tended to accumulate in the various aggregate size classes. Relatively less negative $\delta^{13}\text{C}$ values in the control compared to the organic treatments indicates a lesser labelling effect of the SOM pools in the control treatment. With increased organic matter mineralization, the organic C tends to be distributed to the finer aggregate classes hence the

more negative delta values in the clay and silt fractions. In Embu there was no significant difference in the organic treatments' delta C signatures. Calliandra recorded a delta ¹³C of -19.34‰ and -19.58‰ in the >500 μm and 250–500 μm fractions (macroaggregates), respectively (Table 5). On the other hand, leucaena recorded -19.67‰ and -19.47‰ for the >500 μm and 250–500 μm fractions, respectively while the control treatment recorded -19.23‰ and -19.13‰ for the macro and microaggregates, respectively. On the other hand absolute carbon-13 values in the aggregate size classes in Maseno experiment were more negative in the organic treatments compared to the control and were also more negative compared to the whole soil ¹³C values. The more negative $\delta^{13}\text{C}$ in the clay and silt points to the redistribution of the older organically derived carbon to the finer pools where it is fixed.

Aggregate light fraction (LF) carbon, nitrogen and carbon-13 for Kabete, Embu and Maseno experiments

Table 6 presents the aggregate light fraction TOC for Kabete, Embu and Maseno experiments. There were only slight differences in the aggregate LF C in aggregate classes 250–500 μm and 53–250 μm . On the other hand aggregate LF N was not significantly different for the three classes. The delta carbon-13 signatures

Table 6. Aggregate light fraction total carbon, nitrogen and carbon-13 in Kabete, Embu and Maseno experiments

Treatment	Total Carbon (mg kg ⁻¹ soil)			Total Nitrogen (mg kg ⁻¹ soil)			Delta ¹³ C (‰)		
	>500 µm	250–500 µm	53–250 µm	>500 µm	250–500 µm	53–250 µm	>500 µm	250–500 µm	53–250 µm
Kabete									
Experiment									
Calliandra	252.0	112.3	117.0	12.59	6.94	12.80	-25.23	-19.66	-18.28
Tithonia	143.0	93.9	144.2	6.98	5.59	10.47	-17.70	-17.36	-18.85
Control	204.0	60.6	96.1	9.71	3.30	6.35	-15.21	-16.33	-17.27
SED	42.00	16.46	14.20	1.975	1.492	2.417	2.305	1.150	0.316
Embu									
Experiment									
Calliandra	774.0	202.6	230.0	50.1	15.58	18.9	-22.78	-21.46	-20.32
Leucaena	350.0	119.5	117.0	29.7	10.14	10.1	-21.28	-19.85	-19.42
Control	333.0	104.5	115.0	22.1	8.09	10.0	-20.35	-19.29	-19.12
SED	101.00	15.59	49.70	11.43	1.680	4.28	1.302	0.422	0.546
Maseno									
Experiment									
Calliandra	115.8	88.3	117.0	8.08	5.52	12.80	-22.40	-18.46	-18.28
Tithonia	118.0	77.9	144.2	7.91	4.39	10.47	-16.90	-17.20	-18.85
Control	94.3	72.5	96.1	4.72	3.68	6.35	-17.10	-16.71	-17.27
SED	21.72	7.46	14.20	1.170	0.376	2.417	2.46	0.661	0.316

of the LF in this experiment indicated that calliandra treatments had more of its residues persisting in the soil long after the cropping season. This was evident from the more negative $\delta^{13}\text{C}$ of the >500 µm (-25.23‰), 250–500 µm (-19.66‰) and 53–250 µm (-18.09‰) (Table 6). Tithonia treatments tended to have its LF signatures closer to that of the control; an indication that being of higher quality, most of the tithonia decomposed during the cropping season and hence little persisted in the soil as LF. In Embu experiment, calliandra had the highest TOC in the all the aggregate size classes and these were significantly different for the >500 µm and 250–500 µm fraction (Table 6). This is best explained by the persistence of the calliandra due to its lower quality residues (Palm et al., 2001). One benefit of such large particulate organic matter (POM) in the soil is the potential for continued mineralization and release of nutrients with continued decomposition throughout the season. On the other hand rapidly decomposing organic residues such as leucaena will persist less in the soil and hence the reason for their lower contribution to the POM pool. As with the C in the LF, TON was also higher in calliandra treatment compared to the leucaena and control treatments (Table 6). Light fraction N was significantly different ($P < 0.05$) for the 250–500 µm fraction and was of the order calliandra > leucaena > control.

The carbon-13 signature of the LF were significantly different for the 250–500 µm LF with calliandra recording a delta carbon value of -21.46‰ and was followed by leucaena then the control with delta ¹³C of -19.85‰ and -19.29‰ respectively (Table 6). The above results point out that calliandra contributed more to the SOM pool compared to leucaena and the control. In general, aggregate LFC and N contents were higher in Embu experiment compared to Kabete experiment and this may be attributed to the longer-term application of organic residues which resulted in the accumulation of organic residues in the soil.

In Maseno experiment aggregate LF C was significant for the aggregate class 53–250 µm where tithonia recorded LF C content of 144 mg kg⁻¹ and was followed by calliandra (117 mg kg⁻¹) and the control (96.1 mg kg⁻¹) (Table 6). Aggregate LF N was significantly different for the 250–500 µm class with calliandra recording an N content of 5.52 mg N kg⁻¹ soil while tithonia and the control recorded 4.39 and 3.68 mg N kg⁻¹ soil respectively. There was also a significant difference in the ¹³C signatures for the 53–250 µm LF class with tithonia having the highest delta ¹³C followed by calliandra then the control. In general Embu experiment had more aggregate LF C and N followed by Kabete then Maseno experiment.

Conclusion

The results of this study indicated that SOM tended to vary with organic residue management practices. Secondly, favourable soil C and N can be managed by continued application of organic residues as evident in the Embu experiment. The results also indicated that the ^{13}C signature can be used to evaluate the contribution of the organic residue applied on the whole soil C. By assessing the shifts in the $\delta^{13}\text{C}$ signature between treatments receiving organic residues and the control, predictions can be made on the contribution of the organics to the SOM pools. Complimenting $\delta^{13}\text{C}$ method with SOM fractionation methods can enhance the use of this technique in SOM studies. Soil organic matter fractionation revealed large differences in the SOM mineral and light fractions, a testimony that management regimes of different organic residues will contribute differently to the SOM pools.

Acknowledgements

The authors wish to thank Tropical Soil Biology and Fertility (TSBF Institute of CIAT) for the logistic support and management of the three experiments. Secondly gratitude goes to Katholieke Universiteit Leuven, Belgium for the isotope analysis. This study was funded by the Rockefeller Foundation through a research grant to TSBF-CIAT, Kenyatta University and Kenya Agricultural Research Institute (KARI).

References

- Blair J.G., Lefroy R.D.B. and Lisle L. 1995. Soil carbon fractions based on their degree of oxidation, and the development of a Carbon management Index for agricultural systems. *Australian Journal of Agricultural Research*, 46: 1459–1466.
- Buyanovzky G.A., Aslam M. and Wagner G.H. 1994. Carbon turnover in soil physical fractions. *Soil Science Society of American Journal*, 58: 1167–1173.
- Christensen B.T. 1992. Physical fractionation of soil organic matter in primary particle size and density separates. *Advances in Soil Science*, 20: 1–90.
- Diels J., Vanlauwe B., Sanginga N., Coolen E. and Merckx R. 2001. Temporal variations in plant ^{13}C values and implications for using the ^{13}C technique in long-term soil organic matter studies. *Soil Biology and Biochemistry Journal*, 33 (9): 1245–1251.
- Elliott E.T. 1986. Aggregate structure and carbon, nitrogen and phosphorus in native and cultivated soils. *Soil Science Society of American Journal* 50: 627–633.
- FAO 1990. FAO-UNESCO Soil Map of the World Revised Legend. Soil Bulletin 60 Food Agriculture Organization: Rome.
- FURP 1987. Description of the first priority trial sites in the various districts. Vol. 1–31. KARI, FURP, Nairobi, Kenya.
- Gachengo C.N., Palm C.A., Jama B. and Othieno C. 1999. Tithonia and senna green manures and inorganic fertilizers as phosphorus sources for maize in Western Kenya. *Agroforestry Systems*, 44 (1): 21–35.
- Kimetu J.M. 2002. Nitrogen fertilizer equivalency values for organic materials of contrasting qualities based on maize performance at Kabete, Kenya. MSc Thesis, Kenyatta University, Kenya
- Lefroy R.D.B., Blair G.J. and Comteh A., 1995. Chemical fractionation of soil organic matter and measurement of the breakdown rates of residues. In: Lefroy R.D.B., Blair G.J. and Craswell (Eds) *Soil organic matter management for sustainable agriculture*. ACIAR Proceedings No. 56. ACIAR Canberra, ACT, Ubon
- Mafongoya P.L., Nair P.K.R. and Dzwela B.H. 1998. Mineralization of nitrogen from decomposing leaves of multipurpose tree as affected by their chemical composition. *Biology Fertility Soils* 27: 143–148.
- Mugendi D.N., Nair P.K.R., Mugwe J.N., O'Neill M.K. and Woome P.L. 1999. Alley cropping of maize with calliandra and leucaena in the subhumid highlands of Kenya. Part 1. Soil-fertility changes and maize yield. *Agroforestry Systems* 46 (1): 39–50
- Nandwa S.M. 2001. Soil organic carbon (SOC) management for sustainable productivity of cropping and agroforestry systems in Eastern and Southern Africa. *Nutrient Cycling in Agroecosystems*, 61: 143–158.
- Nziguheba G., Merckx R. and Palm C.A. 2000. Organic residues affect phosphorus availability and maize yields in a Nitisol of Western Kenya. *Biology and Fertility Soils* 32: 328–339
- Ong C.K., Black C.R., Marshall F.M. and Corlett J.E. 1996. Principles of resource capture and utilization of light and water. In: Ong C.K. and Huxley P. (Eds) *Tree-crop interactions: a physiological approach*. CAB International, Wallingford, UK
- Palm C.A. and Sanchez P.A. 1990. Decomposition and nutrient release patterns of the leaves of three tropical legumes. *Biotropica*, 22, 330.
- Palm C.A., Gachengo C.N., Delve R.J., Cadisch G. and Giller K.E. 2001. Organic inputs for soil fertility management in tropical agroecosystems: Application of an organic resource database. *Agriculture, Ecosystems and Environment*, 83: 27–42.
- Parton W.J., Schimel D.S., Cole C.V. and Ojima D.S. 1987. Analysis of factors controlling soil organic matter levels in Great Plains grasslands. *Soil Science Society of America Journal*, 51: 11773–11779.
- Paustian K., Six J., Elliott E.T. and Hunt H.W. 2000. Management options for reducing CO₂ emission from agriculture soils. *Biogeochemistry*, 48(1): 147–163.
- Paustian K., Collins H.P. and Paul E.A. 1997. Management controls on soil carbon, pp. 15–49. In: Paul E.A. et al. (Ed.) *Soil organic matter in temperate agroecosystems: Long term experiments in Northern America*. CRC Press, Boca Raton, FL
- Schwartz D., Mariotti A., Lanfranchi R. and Guillet B. 1986. $^{13}\text{C}/^{12}\text{C}$ ratios of soil organic matter as indicators of vegetation change in the Congo. *Geoderma*, 39: 97–103.
- Six J., Elliott E.T. and Paustian K. 1999. Aggregate and soil organic matter dynamics under conventional and no-tillage systems. *Soil Science Society of America Journal*, 63: 1350–1358.

- Six J., Paustian K., Elliott E.T. and Combrink C., 2000. Soil structure and organic matter: I. Distribution and aggregate-size classes and aggregate-associated carbon. *Soil Science Society of American Journal*, 64: 681–689.
- Sollins P., Spycher G. and Glassman C.A. 1984. Net nitrogen mineralization from light and heavy-fraction forest soil organic matter. *Soil Biology and Biochemistry*, 16: 31–37.
- Tiessen H. and Stewart J.W.B. 1983. Particle size fractions and their use in studies of soil organic matter II. Cultivation effects on soil organic matter in fractions.
- Vanlauwe B. 2004. Integrated Soil Fertility Management research at TSBF: The framework, the Principles, and their Application. In: Bationo A. (Ed.) *Managing nutrient cycles to sustain soil fertility in sub-Saharan Africa*.
- Woomer P.L., Martin A., Albert A., Resch D.V.S. and Scharpenseel A.W. 1994. The importance and management of soil organic matter in the tropics. In: Woomer P.L. and Swift M.J. (Eds) *The Biological management of tropical soil fertility*. Wiley-Syde Publ.: London.

Effects of manure application on crop yield and soil chemical properties in a long-term field trial in semi-arid Kenya

Kihanda F.M., Warren G.P.[†] and Micheni A.N.

Kenya Agricultural Research Institute, Embu Regional Research Centre, PO Box 27, Embu, Kenya; [†]Department of Soil Science, School of Human and Environmental Sciences, The University of Reading, PO Box 233, READING, RG6 6DW, UK.

Abstract

The sustainability of cereal/legume intercropping was assessed by monitoring trends in cereal or legume grain yield, soil organic C (SOC) and soil extractable P (Olsen method) measured over 13 years of field experimentation on a P-deficient soil in semi-arid Eastern, Kenya. Goat manure was applied (annually for 13 years at 0, 5 and 10 t ha⁻¹) and trends in grain yields were not identifiable because of season-to-season variations. SOC and Olsen P increased for the first seven years of manure application and then remained constant. The residual effect of manure applied for four years only lasted another seven to eight years when assessed by yield, SOC and Olsen P. Mineral fertilizers provided the same annual rates of N and P as in 5 t ha⁻¹ manure and initially gave the same yield as manure, declining after nine years to about 80%. Therefore, manure applications could be made intermittently and nutrient requirements topped-up with fertilizers. Grain yields for sorghum with continuous manure were described well by correlations with rainfall and manure input only, if data were excluded for seasons with over 500 mm rainfall. A comprehensive simulation model should correctly describe crop losses caused by excess water

Key words: Manure, semi arid lands

Introduction

In semi-arid sub-Saharan Africa (SSA) it is usual to find great variability of rainfall and low accessibility to technical information and markets, so the early and widespread adoption of fertilizers has not occurred. Manure application is one of the most effective ways of improving fertility in tropical soils. As an example, the production, distribution and application of manure is a vital part of sustainable smallholder arable farming around Kano in northern Nigeria, a semi-arid area with a high population and a long history of arable farming (Dennison, 1961; Harris and Yusuf, 2001). But organic nutrient sources have their own problems, such as limited supplies and the work of handling bulky materials. The effects and costs of organic and inorganic nutrient sources are different, but may be complementary. Thus the combined use of organic and inorganic

nutrient sources is now considered a better way to maintain soil fertility, but comparative information on their long-term effects is scarce.

Both organic and inorganic sources of fertilizer have residual effects in the field. These effects are a vital component of sustainability because they smooth season-to-season variations in soil fertility and crop productivity, but they are difficult to assess quantitatively. Therefore, it is advantageous to undertake well-characterized medium-to-long term experiments rather than single-season trials, and to detail the interactions rather than averaging the responses over different seasons and environments (Tandon and Kanwar, 1984). Long-term implies that primary objectives, treatments and management are not changed during the period under consideration, often regarded as at least 10 years, but unfortunately there is a paucity of long-term experiments in the semi-arid tropics (Laryea et al.,

1995). However, long-term information on soil fertility can still be obtained by monitoring trends in the soil nutrient status even though the pattern of crops may change. The work described here is a development of work at one site of the multi-site experiment first reported by Gibberd (1995). In 1993, it was clear that manure at 5 t ha⁻¹ was widely beneficial, so advantage was taken of the significant soil fertility differences established by then (Warren et al., 1997) to examine residual and long-term effects of soil fertility management.

The general objective of this work was to assess the sustainability of cereal/legume intercropping in semi-arid conditions, by assessing trends in crop yield and soil chemical data collected during more than ten years. Specific objectives were (i) to determine the trends in crop performance and soil nutrient status following application of manure (ii) to assess the residual value of manure on crop yield and (iii) to assess the relative value of manure and fertilizer at the same rates of N and P addition on crop yields

Materials and methods

Field site

The experimental site was at Machang'a, Mbeere District (0°47'S, 37°40'E; 1050m altitude). It was cleared from native bush at the end of 1988, cropping was started in March 1989 and the manure treatments commenced in September 1989. The soil was a sandy clay loam containing 56.5%, 12.7% and 30.8% of sand, silt and clay respectively, with a pH of 6.55 (1:2.5 in water) and provisionally classified as a Chromic Cambisol (Kenya Soil Survey, personal communication). Meteorological data were collected at the site. The biannual

cropping seasons are identified by the month of peak rainfall and the rainfall for each season was assessed by summation of the total rainfall for October–January and March–June for the November (short) and (long) April seasons respectively.

Agronomy

The original experiment had nine treatments comprising three crop rotations and three fertility managements in factorial combination, each with three replicates laid out in randomized blocks. The crop rotations compared intercropping and two sole crop rotations. The fertility treatments were annual (a) additions of goat manure at 0, 5, and 10 t ha⁻¹ year⁻¹. The results from 1989 to 1993 are given by Gibberd (1995). (In February 1993, soil was sampled from all plots, and it was found that the different crop rotations had not created any significant differences in soil organic C (SOC), total N, extractable P (Olsen P) or exchangeable cations (Warren et al., 1997) – take to results section). The intercropped rotation was continued without alteration to manure rates. The sole crop rotation with cereals planted in March and legumes planted in October was discontinued in order to create three new soil fertility treatments with intercropping as described below. The other sole crop rotation continued unchanged and will be reported separately.

The soil fertility treatments are summarised in Table 1. Treatments C, A1 and A2 (what do these treatments stand for) were maintained throughout from 1989 to 2002. The goat manure was obtained from the Ministry of Agriculture's Marimanti experiment station, Tharaka-Nithi District, in September each year, broadcast and immediately incorporated by hand digging. Treatments B1 and B2 (what do these treatments

Table 1. Soil fertility treatments applied at the Machang'a trial. Manure was applied annually in September and fertilizer was applied every season (from October 1993) at approximately 51, 12 and 30 kg ha⁻¹ of N, P and K respectively

Code	Treatment	
	1989 to 1992	1993 to 2002
A1	5 t ha ⁻¹ a ⁻¹ manure	5 t ha ⁻¹ a ⁻¹ manure
A2	10 t ha ⁻¹ a ⁻¹ manure	10 t ha ⁻¹ a ⁻¹ manure
B1	5 t ha ⁻¹ a ⁻¹ manure	None
B2	10 t ha ⁻¹ a ⁻¹ manure	None
C	None (what do you mean by none?)	None
F	None (what do you mean by none?)	NPK fertilizer

stand for) assessed the residual effects after a final manure application in 1992 and treatment F (what do these treatments stand for) assessed the effectiveness of mineral fertilizers on cropped and previously unfertilized soil. In the four years from 1993 to 1996, the manure was sampled and analysed for total C, N, P and K. In these years, the rates of fertilizer N and P in the new treatment F were adjusted in the April season so as to provide equal amounts of N and P in treatments F and A1. From 1997, the fertilizer treatments were 51 kg N ha⁻¹, 12 kg P⁻¹ and 30 kg K ha⁻¹ each season, providing approximately the same annual inputs of N and P as 5 t ha⁻¹ of manure, which were on average 101.5 kg N ha⁻¹ a⁻¹ (year⁻¹), and 23.7 kg P ha⁻¹ a⁻¹ (year⁻¹), from 1993 to 1996.

The crops were (i) sorghum (*Sorghum bicolor*, cv. 954066), intercropped with cowpeas (*Vigna unguiculata*, cv. M66); (ii) pearl millet (*Pennisetum typhoides*, cv. KPM1), intercropped with green gram (*Vigna radiata*, cv. N26) and (iii) maize (*Zea Mays*, cv. Katumani) intercropped with long duration pigeonpea (*Canjunus cajun*, cv. Kimbeere), the latter being a local variety. Cereals were planted in rows 70 cm apart at a spacing of 25 cm within rows, and the associated legume was planted at the same density in extra rows midway between the cereal rows. From 1989 to 1993, the treatments C, A1 and A2 carried a pattern of sorghum/cowpea for two seasons followed by millet/green gram for two seasons as described by Gibberd (1995). From October 1993 this was amended to a rotation (sorghum/cowpea sown in October and millet/gram (green gram sown in March) that closely follows typical local farming practice. From October 1999, cropping was to maize/pigeonpea. The first pigeonpea crop was sown in October 1999, grain harvested in May–August 2002 (why couldn't you harvest the pigeon peas at the same day) and the plots (the crop on the plot) then cleared. The second pigeonpea crop was sown in October 2000 and harvests made in May–August 2001 and 2002 (why couldn't you harvest the pigeon peas on the same day) from the same plants. The intercropped maize was sown every October and March. The plots that were converted to soil treatments B1, B2 and F carried (no plots cannot carry) a rotation of sorghum, cowpea, millet, green gram, with cereals planted in March from 1989 to 1993. From October 1993 they carried the same rotation as treatments C, A1 and A2. At harvest, the grains and above-ground residues (leaves, stalks and threshing residues) were collected separately for each crop. They were air-dried (what mc and weighed at the site.

Soil sampling and analysis

Sampling of the soil commenced in February 1993 and was carried out at intervals of approximately six or twelve months, from the 0–20 cm horizon of all plots. Pits were dug 30×30×30×20 cm within steel frames driven into the soil, subsampled, air-dried and ground by hand to pass a 2-mm aperture sieve, as described by Warren et al. (1997). Three sampling pits per plot were dug at the first (1993) and last (2002) sampling occasions and duplicate pits in 1997, but for reasons of economy financial constraint, only a single sampling pit was used at the other occasions. Olsen P was measured colorimetrically after extraction for 30 min at 20°C and 1:20 w/v soil:reagent ratio with 0.5 M NaHCO₃ adjusted to pH 8.5. SOC was measured by heating finely-ground soil for 2 h at 130–135°C with H₂SO₄/H₃PO₄/K₂Cr₂O₇ mixture and back-titration with (NH₄)₂Fe(SO₄)₂.

Statistical methods

Season-to-season variability in the results makes (made) it difficult to discern the differences and trends which may indicate the stability and sustainability of the cropping systems. Therefore the grain yield, Olsen P and SOC data were analysed for variation for each season individually, and also by linear regression over sequences of seasons to search for trends. Statistical calculations were performed with INSTAT (Stern et al., 1990).

Regression modelling of grain yields

Empirical equations of the following form were fitted to grain yield (Y) for the continuous treatments (C, A1, A2):

$$Y = a + bR + cM^x + dR \times M^x \quad (1)$$

where R was the seasonal rainfall (mm), M was the annual manure rate (t ha⁻¹), and *a*, *b*, *c*, *d* and *x* were fitted parameters. A preliminary matrix of correlation coefficients showed that Y was always correlated much more closely with R×M than either R or M alone. Then parameter *x* was selected to give the highest correlation between Y and R×M^{*x*}, and the significant terms and regression coefficients were obtained using stepwise multiple regression.

Trends over time in soil properties under continuous manure

For soil data, the trend over several seasons for each measurement and treatment was described by linear regression with time (T) in years as the explanatory variable. Soil data for continuous manure treatment were considered in two phases, 1993 to 1997 and 1997 to 2002. 1997 was chosen as the dividing year because of the more intensive soil sampling carried out in that year. For 1989 to 1997, the value T=0 was set to 1 January 1989, approximately the start of the experiment, and for 1997 to 2002, T=0 was set to 1 January 1997. Comparisons between continuous manure treatments were then made by pooling the data for these treatments and a set of joint regression lines, either parallel to each other or diverging from a common origin at 1989, was fitted using multiple regression with factors (Draper and Smith, 1981).

Assessment of manure residual value

For each season from 1993 to 2002, the residual value (RV) of manure for grain yield was assessed by the response to residual manure divided by the response to continuous manure, calculated as follows:

$$RV_i = \frac{\text{Yield}(B_i) - \text{Yield}(C)}{\text{Yield}(A_i) - \text{Yield}(C)} \quad (2)$$

where A_i denotes continuous manure at rate i , B_i denotes residual manure at rate i and C denotes the no manure treatment. RV should therefore vary between 1.0 for a residual effect as good as fresh manure and 0.0 when there is no residual effect. Residual values also were assessed by the responses in Olsen P and SOC, calculated by equation 2, with the substitution of yield by Olsen P or SOC values. The trends in yield and soil data were assessed by linear regression with time (T) in years as the explanatory variable. The value T=0 was set to 1 January 1993 since the new treatments commenced during 1993.

Comparison of fertilizer and manure

For each season from 1993 to 2002, the relative effect of fertilizer in comparison with manure was assessed

by the fertilizer to manure ratio (FMR) for cereal grain yields calculated as follows:

$$FMR = \frac{\text{Yield}(F)}{\text{Yield}(A1)} \quad (3)$$

FMR was also assessed for Olsen P and SOC, calculated by equation 3, with the substitution of yield by Olsen P or SOC values. The trends in yield and soil data were assessed by linear regression with time (T) in years as the explanatory variable. The value T=0 was set to 1 January 1993.

Results

Weather (was the study of weather pattern one of your observation)

From 1990 to 2002, the mean annual rainfall was 789 mm (this is not true according to figure 1 most of the mean annual measurements are below 700mm) bimodally distributed with peaks in November and April (Figure 1). Seasonal rainfall varied from 100 to 1030 mm and appeared more variable from 1997 onwards (Figure 1). Mean annual class 'A' pan evaporation was 1993 mm, and the mean daily maximum and minimum temperatures were 29.0° and 16.6° respectively.

Continuous manure (residual value of continuous manure application)

Grain yields. For the unmanured plots (treatment C), the first season (of which year) gave the highest yields of cereals and legumes (Figure 2) and from then on, yields remained low every year. For the continuously manured plots (A1 and A2), yields were higher in the earlier years (approximately 1989–1995), when manure gave significant increases in cereal yield in almost every season and legume yield in three seasons. However, 10 t ha⁻¹ manure did not give any significant extra grain yield compared to 5 t ha⁻¹ manure (Figure 2). In the period 1996–1998, all yields were low. For the cereals, this is attributed mainly to adverse weather conditions, e.g. the November seasons of 1996, 1997 and 1998 provided the highest and the two lowest rainfalls on record for that season (Figure 1). Yields could be depressed by high rainfall. In the November 1992 season, rainfall was the second highest on

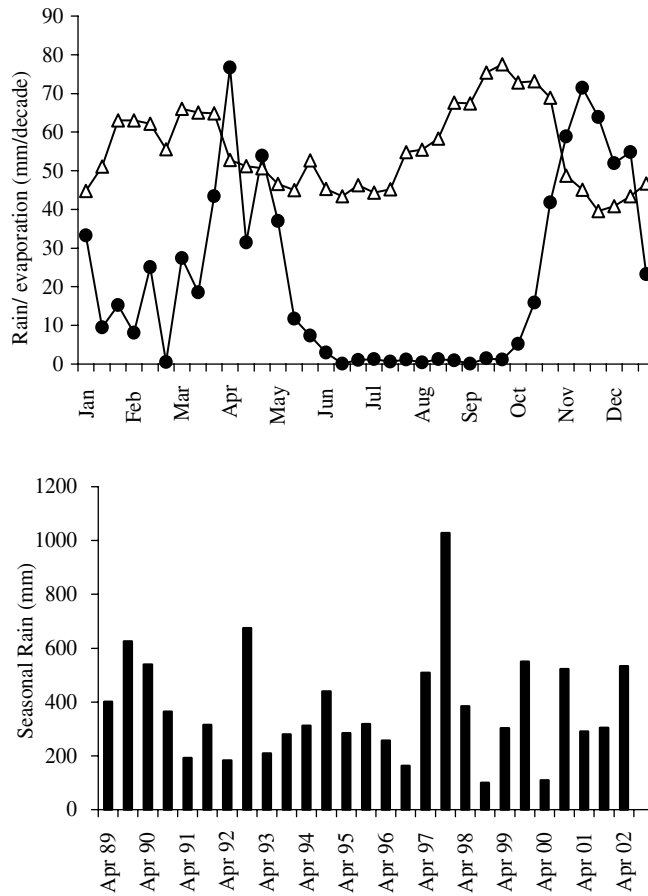

Figure 1. Mean rainfall (●) and class ‘A’ pan evaporation (Δ) in “decades” (10-day periods), averaged over the period 1990–2002, and rainfall during each cropping season, assessed by summation of the rainfall from 1 October to the following 31 January for each November season and from 1 March to 30 June for each April season.

record but the sorghum yield was only about half that of the best season. In the extreme case of January and February 1998, an exceptionally extended rainy season caused complete loss of the November 1997 season’s grain harvest, which rotted in the field and the yield had to be recorded as missing data. For the legumes, yields declined after 1992 (Figure 2) and this was caused by an increasing incidence of disease. Cowpeas usually failed to set seed after 1995 because of root rot, which became endemic in the plots. After the intercropped plots were converted to the maize/pigeonpea system, grain yields were generally better (Figure 2), although it is likely that this was in part due to more favourable rainfall patterns.

The relationships between grain yield and seasonal rainfall were plotted for each rate of manure (Figure 3). For sorghum, it appeared that the yield was correlated with rainfall up to about 500 mm of seasonal rain, and

that the response to extra rain was greater if manure was applied. An empirical regression equation gave a close description of the sorghum grain yield data for eight seasons in a period of nine years, excluding (i) the initial season before manure was first applied (4/89); and (ii), the two seasons when rainfall exceeded 500 mm. The term for rainfall (R) in equation (1) was not significantly different from zero, and strong significant ($p < 0.001$) relationship was found as follows:

$$Y = a + b M^{0.3} + c R \times M^{0.3} \quad (4)$$

where $a = 146.7$, *s.e.* 78.9; $b = -867$, *s.e.* 92.7; $c = 5.89$, *s.e.* 0.29 and $r^2 = 0.963$. This equation can be written in the following alternative form:

$$Y = 146.7 + (5.89.R - 867) \cdot M^{0.3} \quad (5)$$

This suggests that (i) a certain minimum rainfall ($R = 867/5.89 = 147\text{mm}$) is essential for grain production,

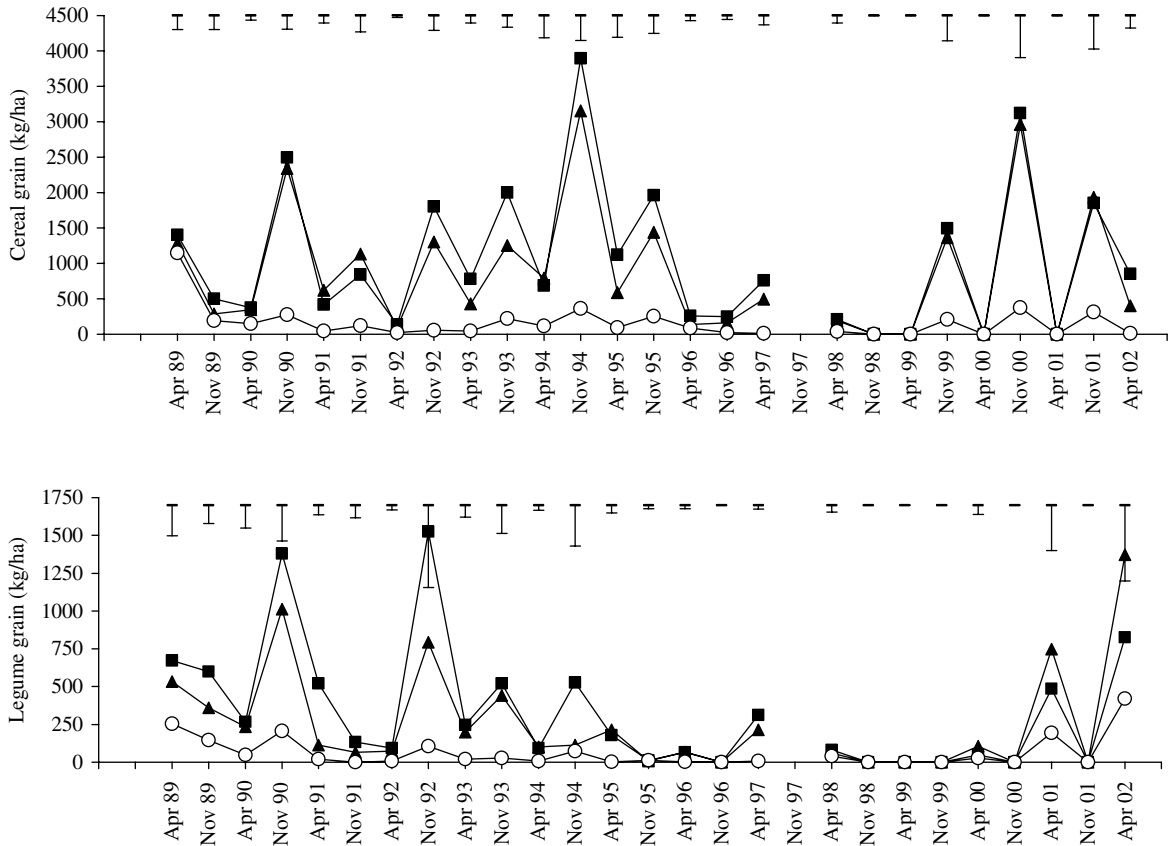

Figure 2. Grain yields of cereals and legumes in each season with intercropping and soil fertility treatments C (●) (wrong (○)), A1 (▲) and A2 (■), in which 0, 5 and 10 t ha⁻¹ a⁻¹ manure respectively were applied. Vertical bars equal the *s.e.d.* (what is this?) for each season.

which is otherwise negative according to this equation, and (ii) that above the minimum rainfall, yield depends on the product of R and M, showing that there is a strong positive interaction between rainfall and soil fertility.

For millet, cowpea and green gram, the yields in relation to rainfall were much more scattered (Figure 3). For the legumes, the response to extra rain was better in the manured treatments. Close correlations of yield with M and R×M were not found, although for millet at rainfall less than 350 mm, the following relationship was significant:

$$Y = a + bM^{0.1} + cR \times M^{0.1} \quad (6)$$

where $a = 85.8$, *s.e.* 92.2, $b = -994$, *s.e.* 313, $c = 5.18$, *s.e.* 1.11 and $r^2 = 0.774$.

Maize and pigeonpea yields were obtained in four and three seasons respectively, which were not enough data to obtain meaningful relationships between yield and rainfall.

Olsen P. (residual value of manure application on *Olsen P*?) Significant increases in *Olsen P* were caused by manure application. Compared to the control, treatment A2 caused significant increases in *Olsen P* at almost every sampling (Figure 4), but the increase caused by treatment A1 was never large enough to be significant in any one season. *Olsen P* in treatment A2 was significantly more (higher) than in A1 in nine out of 13 sampling occasions. In 1993, continuous manure application had created significant differences between treatments C, A1 and A2 (Warren et al., 1997), the *Olsen P* values being 1.0, 2.1 and 3.3 mg kg⁻¹ respectively (of *Olsen P*?). By 2002, the *Olsen P* values were 1.0, 2.6, and 8.9 mg kg⁻¹ respectively (Figure 4). This suggested that trends in *Olsen P* should be observable. (meaning?)

From 1993 to 1997, the trends in *Olsen P* shown by regressions on time were small for treatment C, a little upward in A1 and distinctly upward in treatment A2 (Figure 4). But, because of the variability of results, no

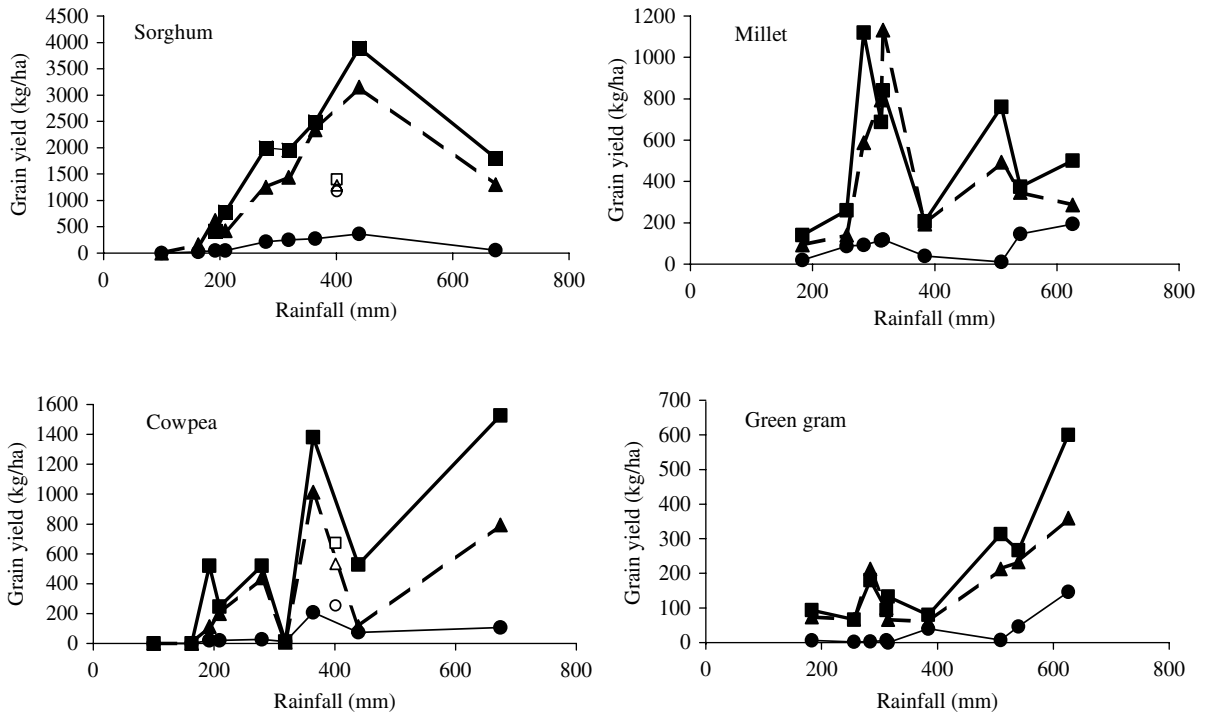

Figure 3. Relationships between grain yield of sorghum, cowpea, millet and green gram, and seasonal rainfall, with intercropping and soil fertility treatments C (●), A1 (▲) and A2 (■), in which 0, 5 and 10 t ha⁻¹ a⁻¹ manure respectively were applied. Yields for the season before manure application started (April 1989) are shown in open symbols (○, △, □) for treatments C, A1 and A2 respectively.

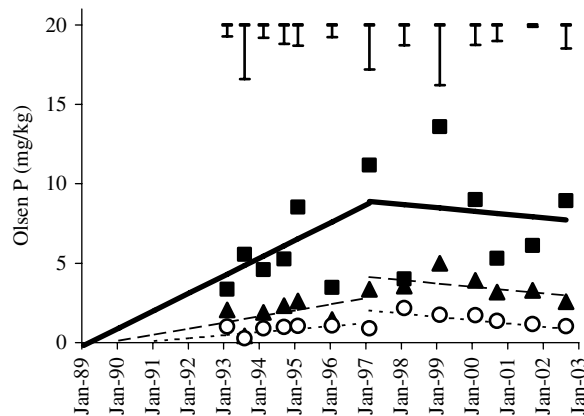

Figure 4. Soil Olsen P for intercropped treatments C (○), A1 (▲) and A2 (■), in which 0, 5 and 10 t ha⁻¹ a⁻¹ manure respectively were applied. Vertical bars equal the *s.e.d.* for each season. Fitted joint regression lines (*s.e.* of parameter) for 1993 to 1997 were: treatment C (.....) $P=0.277(1.533)+0.188(0.267)T$; treatment A1 (—) (*wrong line formatting*) $P=0.277(1.533)+0.383(0.267)T$; and treatment A2 (—) $P=0.277(1.533)+1.112(0.267)T$. Fitted joint regression lines for 1997 to 2002 were: treatment C (.....) $P=2.06(1.06)-0.211(0.245)T$; treatment A1 (—) (*do you want to mean —?*) $P=4.17(1.06)-0.211(0.245)T$; and treatment A2 (—) (*increase thickness*) $P=8.92(1.06)-0.211(0.245)T$.

trend line gradient for an individual treatment was significantly different from zero, although Olsen P must have been the same in all treatments in 1989 and a significant difference (what level of difference?) between treatments C and A2 had developed by 1993. When projected backwards to 1989, the fitted lines tended to a common origin as should be expected. Therefore, data for the three treatments were pooled and a set of joint regression lines was fitted, each of the following form, one equation for each treatment:

$$\text{Olsen P (mg kg}^{-1}\text{)} = a + b T \quad (7)$$

(what does a and b stand for?)

They started at a common origin with $T=0$ set to 1 January 1989, and had separate slopes. A good fit was obtained ($r^2=0.782$), shown in Figure 4. The rate of increase of Olsen P was highly significant in treatment A2 but not in treatments C and A1, in agreement with the significant differences between treatments at each of the 1993 to 1997 samplings (Figure 4).

From 1997 to 2002, the trends in Olsen P were slightly downward in all treatments (Figure 4). The downward trends of individual treatments were not significantly (significance level?) different from zero or each other, but treatment effects in each season were consistently in the order $C < A1 < A2$. These results were pooled and three parallel lines (each as equation 7) with separate intercepts were fitted by joint regression, with $T=0$ set to 1 January 1997. The joint downward slope was not significantly different from zero and Olsen P in treatment A2 was significantly higher than in treatment A1 ($p=0.01$). The difference between treatments C and A1 was not quite large enough to be significant at the 5% level.

Soil organic C. Compared to the control, treatments A1 and A2 caused significant increases in soil organic C at almost every sampling (Figure 5), but the difference between treatments A1 and A2 was never significant.

From 1993 to 1997, the trend in SOC was small for treatment C and distinctly upward in treatments A1 and A2 (Figure 5). But because of the variability of results, none of the gradients of the individual trend lines was significantly different from zero, although the initial SOC must have been the same in all treatments and a significant difference between treatments C and the manured treatments had developed by 1993. The initial SOC would be the same in all plots and when projected backwards in time, the trend lines tended to a common origin as might be expected. These data were pooled

and sets of joint regression lines based on a common origin and separate slopes were fitted to the equation:

Note: give significance levels

$$\text{SOC(g kg}^{-1}\text{)} = a + b T \quad (8)$$

where $a = 6.28$, *s.e.* 0.891, and $b = -0.053$, 0.296 and 0.328, for treatments C, A1 and A2 respectively, *s.e.* 0.155 ($F=8.98$; $r^2=0.658$) (where F in the above equation?). The rate of decline of SOC in the control treatment was not significant, while in the manured treatments, the rate of increase was not quite large enough to be significant and there was no significant difference between treatments A1 and A2. The data for treatments A1 and A2 were combined, and a regression line (equation 8) was estimated, where $a = 6.28$, *s.e.* 0.865, and $b = 0.312$, *s.e.* 0.145, in which the rate of increase of SOC was significant ($p=0.05$). These results are in agreement with the individual differences between treatments for the 1993 to 1997 samplings and show that annual manure application increased SOC up to 1997, but there was no difference between treatments A1 and A2.

From 1997 to 2002, the trends in SOC were declined in all treatments (Figure 5). The downward trends were not significantly different from zero or each other and treatment effects in each season were consistently in the order $C < A2 \sim A1$ (Figure 5). These results were pooled, three parallel lines were fitted by regression, with $T=0$ set to 1 January 1997. The set of regression lines was described by equation (8), where $a = 5.98$, 8.72 and 9.48 for treatments C, A1 and A2 respectively, *s.e.* 0.35, and $b = -0.154$, *s.e.* 0.081. ($F=692$; $r^2=0.994$). The combined downward slope was still not significantly different from zero, SOC in treatments A1 and A2 was significantly different from C ($p=0.001$), and there was no significant difference between treatments A1 and A2. These results suggest that in the manure treatments after 1997, a new dynamic equilibrium had been reached between C inputs and decomposition.

Residual of manure treatments

Grain yields. The assessment of manure residues started in November 1993, and significant differences between continuous and residual manure treatments were not normally found in any one subsequent year because of the variability. In many years there were no significant effects of manure, either continuous or residual, on crop yields. Only cereal yield data

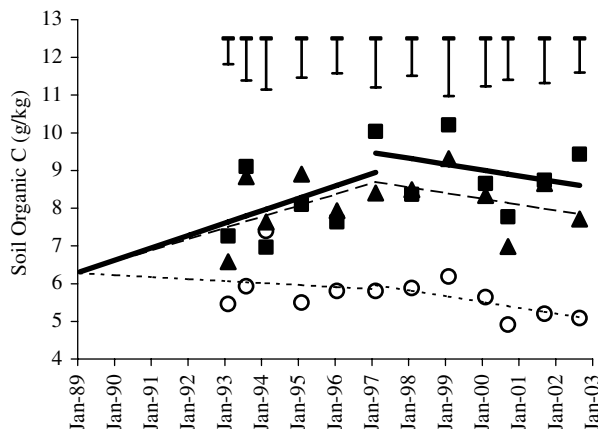

Figure 5. Soil organic C for intercropped treatments C (O), A1 (\blacktriangle) and A2 (\blacksquare), in which 0, 5 and 10 t ha⁻¹ a⁻¹ manure respectively were applied. Vertical bars equal the *s.e.d.* (what is *s.e.d.*?) for each season. Fitted joint regression lines (*s.e.* of parameter) for 1993 to 1997 were: treatment C (.....) SOC = 6.28(0.891) (0.053(0.155)T; treatment A1 (——) SOC = 6.28(0.891) + 0.296(0.155)T; and treatment A2 (——) SOC = 6.28(0.891) + 0.328(0.155)T. Fitted joint regression lines for 1997 to 2002 were: treatment C (.....) SOC = 5.98(0.35) — 0.154(0.081)T; treatment A1 SOC = 8.72(0.35) — 0.154(0.081)T; and treatment A2 (——) (increase thickness) SOC = 9.48(0.35) — 0.154(0.081)T.

were used because legumes were affected by disease (which disease?). Residual Value (RV) could not be calculated for seasons of severe drought or missing data and the values were rather scattered (Figure 6). Nevertheless, the linear regression between RV and time showed a highly significant ($p = 0.001$) downward trend, described by the following equation, where time (T) was zero for 1 January 1993.

$$RV = a + bT \quad (9)$$

where $a = 0.820$, *s.e.* 0.087, and $b = -0.0727$, *s.e.* 0.0157 ($r^2 = 0.495$). The confidence limits ($p < 0.05$) for the fitted mean regression line were plotted and projected back to April 1993 (Figure 6). They showed that (i) from April 1993 to December 2001, RV was significantly less than one but more than zero, (ii) at April 1993, RV was not significantly different from one (this should be the case since the last manure application was the previous year), and (iii) by January 2002, RV was not significantly different from zero. These data suggest that the effects of manure lasted approximately eight years, from the first residual effect season (November 1993) until December 2001.

Olsen P. Residual Value data were rather scattered (Figure 6), but the linear regression of RV with time showed a highly significant ($p = 0.01$) downward trend, described by equation 9, where $a = 0.980$, *s.e.* 0.165, and $b = -0.0897$, *s.e.* 0.0305 ($r^2 = 0.265$). The confidence limits ($p < 0.05$) for the fitted mean regression line were wider than for grain yield data (Figure 6) and

showed that by September 2000, RV was not significantly different from zero. These data suggest that the residual effects of manure on Olsen P lasted approximately seven years, until eight years after the final manure application.

Soil organic C. The Residual Value data showed a clear downward trend (Figure 6), and the linear regression of RV with time was significant ($p = 0.001$), described by equation 9, where $a = 1.169$, *s.e.* 0.107, and $b = -0.0941$, *s.e.* 0.0183 ($r^2 = 0.568$). The confidence limits ($p < 0.05$) for the fitted regression line showed that by September 2002, RV had almost reached the point of being not significantly different from zero. These data suggest that the residual effects of manure on SOC lasted (for) approximately eight years, until nine years after the final manure application.

Comparison of fertilizer and manure (replace by relative value of manure and fertilizer?)

Grain yields. Only cereal yields were considered because legumes were badly affected by disease (which one?) in the period under consideration. In every season, there was no significant difference between treatments F and A1 in grain yield. The relative effect of fertilizer in comparison with manure (FMR) showed a downward trend (Figure 7), and the linear regression of FMR with time was significant ($p = 0.05$).

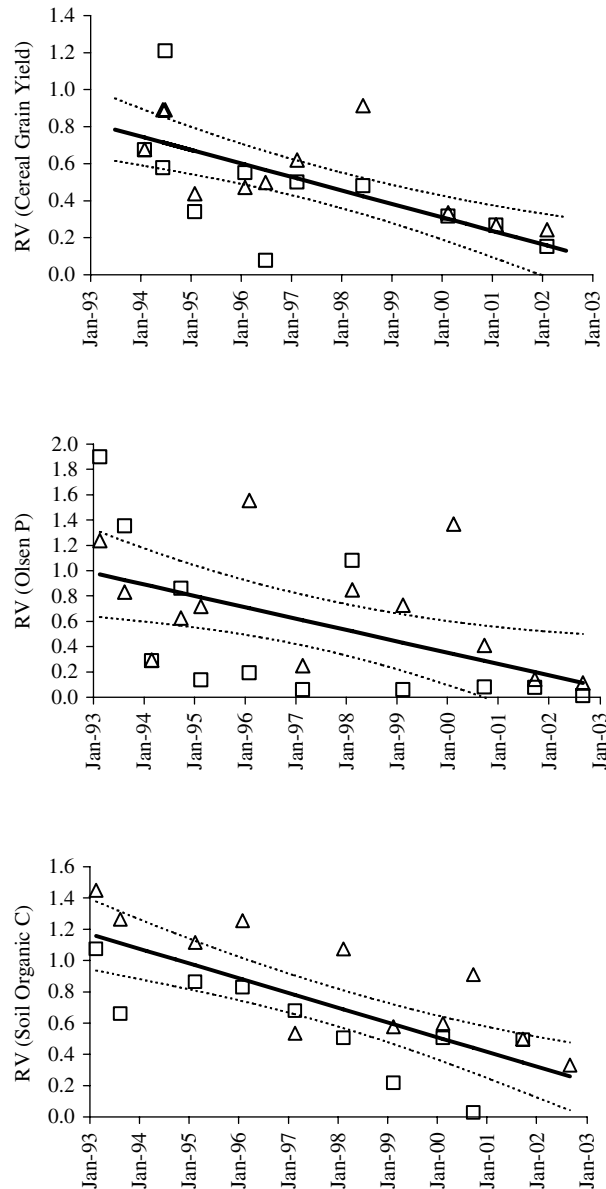

Figure 6. Residual value (RV) of manure, calculated as response to residual manure (treatment B) (not described anywhere in the methodology) divided by the response to continuous manure (treatment A), at 5 t ha⁻¹ manure (Δ) and 10 t ha⁻¹ manure (\square) for cereal grain yield, Olsen P and SOC. Solid lines show the fitted linear regression of RV with time (T years, starting 1 January 1993). Fitted lines (s.e. of parameters): RV (Grain Yield) = $0.820(0.087) - 0.0727(0.0157)T$ ($r^2 = 0.495$); RV (Olsen P) = $0.980(0.165) - 0.0897(0.0305)T$ ($r^2 = 0.265$); and RV (SOC) = $1.169(0.107) - 0.0941(0.0183)T$ ($r^2 = 0.568$). Dotted lines delimit the 95% confidence intervals of the fitted lines.

The confidence limits ($p < 0.05$) for the fitted regression line showed that by the April 2002 season, FMR was less than one. Therefore, by 2002, fertilizer was not as effective as manure even though the same amounts of N and P had been applied from 1993 to 2002.

Olsen P. During the period from 1993 to 2002, Olsen P was on average higher in treatment F (4.2 mg kg⁻¹) than in treatment A1 (3.0 mg kg⁻¹) even though the total amount of P applied since the start of the experiment was greater in treatment A1 than in treatment F, the quantities being approximately 261 kg ha⁻¹ and

159 kg ha⁻¹ respectively. The slope of the regression of FMR with time was not significantly different from zero (Figure 7), so fertilizer consistently increased Olsen P more than manure at the same rate of P application.

Soil organic C. There was no significant trend in FMR for SOC with time over the period 1994–2002 (Figure 7) although the apparent trend was up rather than down. In 1994, SOC was significantly less in treatment F than in treatment A1, as would be expected since treatment A1 had received five applications of manure at 5 t ha⁻¹, while treatment F had received none. By 2002, FMR was not significantly different from 1.0 (Figure 7). These results are tentative evidence that fertilizer had increased the soil organic matter.

Discussion

Effects of continuous manure (on what?)

Short duration sorghum in the tropics generally requires between 500 and 600 mm of well-distributed rainfall to give optimum yield in conditions of fertile soil (Chantereau and Nicou, 1994). Grain yield results at Machang'a agreed perfectly with this observation, because the best yields were obtained at around 500 mm of rainfall and when this was exceeded, yield was reduced (Figure 3).

Interactions (positive or negative?) occur between water and the availability of nutrients because water increases the rate of release of nutrients from organic or insoluble forms and enables their transport to plant roots and losses from the soil. For all crops, there was a strong interaction between soil fertility and water supply: the higher the manure rate, the better the response to water (Figure 3). This was particularly clear for sorghum. For sorghum, when rainfall was more than about 250 mm, fertility was more limiting than water because additional rainfall in the unmanured soil never gave as high a yield as manure with 250 mm rainfall (Figure 3). Nutrients supplied in less soluble forms are less prone to loss, and more suitable than mineral fertilizers when rainfall tends to be irregular and then heavy.

Without manure or fertilizer, SOC declined slowly, as would be expected. The degradation of soil organic matter by continuous cultivation has long been known and a comparison of cultivated and forest soils in Nigerian soils showed that cultivated soils contained about half of the SOC in forest soils (Jones, 1973). Loss

of SOC was lower in soils with higher clay content. Machang'a soil has a clay content of 30.8% and the loss of SOC at Machang'a was slow, the trend being a loss rate of 0.5% and 1.5% per year in 1993–1997 and 1997–2002 respectively. In contrast, Jones and Wild (1975) concluded that more sandy West African soils lost C at 5 to 10% per year until reaching a SOC content of 25–45% of the value under natural vegetation.

After 13 applications, manure had increased SOC at Machang'a by 52% and 85% in treatments A1 and A2 respectively, compared with treatment C. This increase is comparable to the 40% increase caused by annual 4.9 t ha⁻¹ manure over 15 years in Nigeria (Bache and Heathcote, 1969). De Ridder and van Keulen (1990) concluded that 5 t ha⁻¹ manure was needed to maintain SOC in West Africa. In some agreement, this application rate at Machang'a resulted in a steady increase of SOC for about seven years to 1997, after which, a new dynamic equilibrium appeared to be reached (Figure 5). At Machang'a, extra manure, up to 10 t ha⁻¹, did not create significantly more SOC than 5 t ha⁻¹, at any time. Clay is the most important soil component that stabilises SOC, and it was not low at Machang'a. However, X-ray diffraction analysis of separated clay showed that it contained approximately 60% kaolinite, a clay mineral of low surface area, charge and chemical activity, which may be unable to stabilise much SOC. It is suggested that the SOC concentration reached by 1997 is about the highest amount that can be sustained in this soil and that additional C input in manure was lost as CO₂.

Olsen-P is a widely accepted test for plant-available P, and in the semi-arid tropics, a value of 5 mg kg⁻¹ is a commonly accepted critical value, above which P is unlikely to be limiting. By 1994, Olsen-P was near or above 5 mg kg⁻¹ in treatment A2, while Olsen-P in treatment A1 remained below this critical value up to 2002 (Figure 4), suggesting that P availability was a fertility constraint at 5 t ha⁻¹ manure treatment throughout the experiment. The increase in Olsen P caused by treatment A1 was never quite large enough to be significant, either in an individual season or when assessed by trends. This suggested that the P applied in manure at 5 t ha⁻¹ was little more than that required for crop P uptake and immobilisation in soil, since P is not subject to gaseous loss and leaching losses are normally small. From 1993 to 1997, manure at 10 t ha⁻¹ (A2) clearly resulted in surplus P, which increased the labile P pool in the soil, assessed by Olsen P (Figure 4). From 1997 to 2002, there was no further rise in Olsen

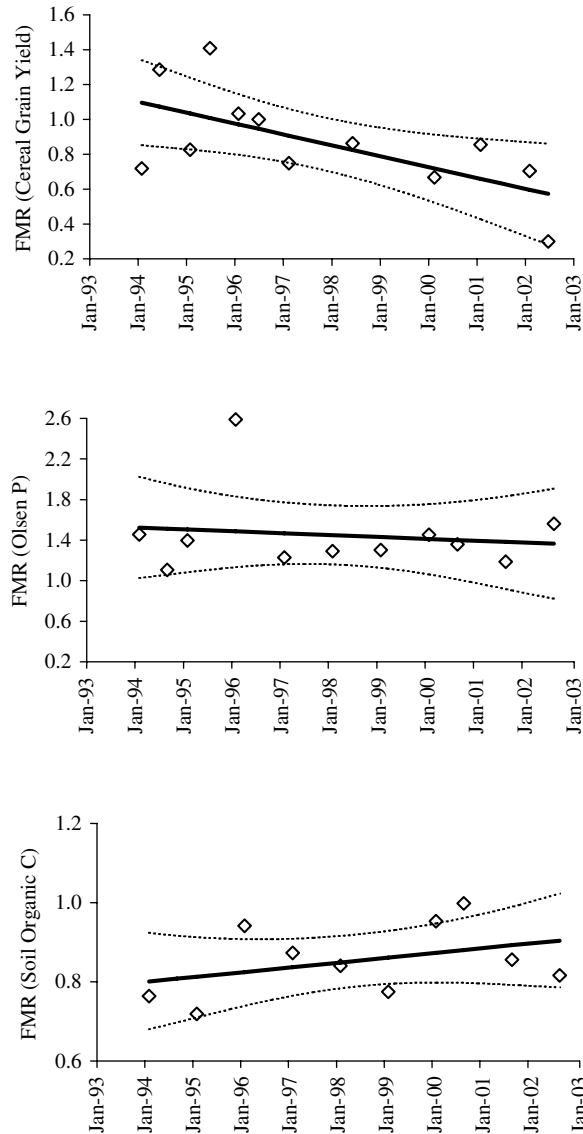

Figure 7. Relative effect of fertilizer and manure (FMR; \diamond), calculated as the ratio between the results for treatments F and A1 (fertilizer and 5 t ha⁻¹ manure respectively) for cereal grain yield, Olsen P and SOC. Solid lines show the fitted linear regression of FMR with time (T years, starting 1 January 1993). Fitted lines (*s.e.* of parameters): FMR (Grain Yield) = 1.164(0.131) - 0.0625(0.0235)T ($r^2 = 0.414$); FMR (Olsen P) = 1.544(0.263) - 0.0186(0.0448)T ($r^2 = 0.019$); and FMR (SOC) = 0.787(0.063) - 0.0121(0.0102)T ($r^2 = 0.148$). Dotted lines delimit the 95% confidence intervals of the fitted lines.

P, suggesting that a new dynamic equilibrium had been reached between P inputs, offtakes, immobilisation and mineralisation. This interpretation is supported by a partial nutrient budget. Uptakes of P by crops in the year October 1994 to September 1995 were 2.0, 14.8 and 24.0 kg P ha⁻¹ in treatments C, A1 and A2 respectively, compared to inputs in manure of 0, 23.5 and 46.9 kg P ha⁻¹. These data show a surplus of P that was 2.7 times greater for A2 (22.9 kg P ha⁻¹) than for A1 (8.6 kg

P ha⁻¹). This is approximately in line with the finding that, in February 1995, Olsen P was 3.2 times higher in treatment A2 than for A1.

Residual value

The assessment of residual value in the field is always difficult because of the expense and commitment

needed to maintain work over several years and season-to-season variations in crop growth. The procedure used here, of calculating RV relative to no-manure and continuous manure enabled trends to be observed and results calculated with grain yield, SOC and Olsen P agreed rather well.

Manure applied for four consecutive years increased grain yield up to nine years later, which is a longer period than has been commonly reported elsewhere in semi-arid dryland agriculture, such as three years for maize at Katumani (MKS) Kenya (Ikombi, 1984), two to three seasons in India (Singh and Desai, 1991) and three seasons in Botswana (Carter et al., 1992). Williams et al. (1995) estimated that the annual breakdown of manure was in the ratio 50:40:10 over three years. At Machang'a, the long residual effect on yield was supported by the residual effects lasting seven years for Olsen-P and eight years for SOC. Long manure residual effects of nine years for millet and 13 years for cotton were also reported by Peat and Brown (1962) in Tanzania. RV for 10 t ha⁻¹ manure was no better than for 5 t ha⁻¹ manure (Figure 6), enabling calculation of a combined regression for the trend. This was because the higher manure rate did not create (add) significantly more SOC (Figure 5).

Fertilizer

The apparent increase of SOC in soil receiving only inorganic fertilizer was notable. An increase is to be expected because fertilizer increases biomass production and therefore the C input to soil from roots and crop residue. Similarly, applications of ammonium sulphate and single superphosphate over 15 years caused a small increase in soil C in the savanna zone of northern Nigeria (Bache and Heathcote, 1969). The increase in SOC caused by mineral fertilizers is predicted for Machang'a soil by simulation modelling (Micheni et al., in press).

The rates of N and P application were almost the same in treatments A1 and F, but predominantly as organic forms in A1 and inorganic in F. The two treatments are not exactly comparable, since treatment A1 had been commenced in 1989 and reserves of soil organic matter and nutrients had been built up. This was expected to give an advantage to the manure treatment at the start. During the period of study, the effects of manure and fertilizer on grain yields were the same at the start of the comparison period, showing that initially, organic and inorganic sources of P were

equally effective. Olsen P was maintained at a higher concentration by fertilizer, so the supply of P was not the cause of the difference between the treatments in grain yield. SOC tended to increase under fertilization, and by 2002 was not significantly different between the two treatments, so it is not clear that inadequate SOC was responsible for the relative decline in yield from fertilizer. (GENERALLY – try to discuss your observations well)

Optimisation of soil fertility management

Manure and mineral fertilizers can be complementary methods of soil fertility improvement. Manure is however, in short supply, bulky and heavy so there is substantial work in applying it, and farmers around Machang'a report that it can introduce weeds and pests. Even in the successful manure-based farming system around Kano, Nigeria, livestock manure does not provide all the nutrients required for sustainable crop production (Harris and Yusuf, 2001). Labour may be saved by using mineral fertilizers, which are a more concentrated form of nutrients. However, they require cash for their purchase, so are difficult for (poor) smallholder farmers to acquire, and cannot maintain crop yields as well as manure (sentence is unclear). Based on the good residual value of manure, up to about eight years, manure can be applied intermittently and supplemented by mineral fertilizers in the intermediate years, to boost levels of immediately available nutrients.

There are very many possible combinations of organic and mineral fertilizers that could be applied over a period (of) up to about eight years, since organic and mineral N, P and K components can be applied separately. Field experiments over this time would be very expensive and inflexible. The development of suitable combinations could be better investigated through simulation modelling. Successful application of the principle of a long-interval manure rotation at the farm level requires farmer-participatory research, so that the many options could be reduced by the farm-specific biophysical and socioeconomic constraints.

Implications for simulation modelling

Simulation models of agro-ecosystems provide means of prediction beyond the bounds of experience or experimentation, and a credible model must handle

long-term effects if it is to be useful in the assessment of sustainability. In the Machang'a experiment, most results for sorghum grain, the major product, were described well by correlations with data for only water and nutrient inputs, suggesting that mathematical description, and hence successful simulation modelling, should be achievable for this data set. The data excluded were those for the initial season, before fertility treatments were applied and for seasons when above-optimum rainfall occurred. This shows that a comprehensive simulation model to describe food output for all seasons must correctly describe system response to excess water. However, this could be difficult, because the grain yield losses, especially in the November 1997 season, were caused by events, spoilage in the field, which are unconnected with soil conditions.

Conclusions

Long-term experiments provide information on the sustainability of agricultural systems that can be obtained in no other way. The Machang'a manure experiment described here is one of few extant field experiments in semi-arid Africa of >10 years' duration with constant soil fertility treatments. It is representative of the farming systems of this region because it has used the most important grain crops of the region, a typical crop rotation, has components with manure and fertilizer, and was conducted in a "near-farm" situation with local management.

Sustainability of arable cultivation is difficult to define precisely, but may be defined as adequate crop production over an extended period without degradation of the natural resource base. At Machang'a, trends in grain production were not identifiable over 13 years because of the season-to-season variations, caused by variation in rainfall. Because of the central role of soil organic matter in maintaining soil fertility, SOC has been proposed as an indicator of sustainability in a soil management system (Greenland, 1994). This is justified by our results. In contrast to the grain yield data, trends and stable differences between treatments could be identified with SOC and Olsen P.

Two distinct phases were observed in the changes of SOC and Olsen P, from 1993 to 1997, and 1997 to 2002. In the first phase soil fertility increased, and in the second it remained approximately stable, appearing to reach a new dynamic equilibrium. C and P behaved differently. Manure at 5 t ha⁻¹ increased SOC, but gave

only a small increase in Olsen P, probably because P supply did not greatly exceed demand. Manure at 10 t ha⁻¹ gave no extra SOC over that generated by 5 t ha⁻¹ manure, and the extra C applied must have been lost. On the other hand, the higher manure rate increased Olsen P substantially because supply exceeded demand and there are few loss mechanisms for P.

Results for the residual manure treatments showed that the residual effect of manure could last at least seven years, a longer period than had been expected. Manure applications can be made intermittently and P and some N are stored in the soil. Nutrient supply in intermediate years may be improved with mineral fertilizers although they cannot maintain fertility in the long run. There are very many possible possibilities for the combinations of rates and timing of application of these organic and inorganic inputs, and they should be assessed by simulation modelling and tested with site-specific farmer-participatory research.

Acknowledgements

We thank the following: The Rockefeller Foundation for encouragement and financial support of this work; P.I. Mutwiri, C. Ndwiga and A. Kinyua for field site management; the Director, KARI Embu RRC for provision of facilities; and V. Gibberd and the Department for International Development, UK, for support of, and information about, the earlier years of the field work.

References

- Bache B.W. and Heathcote R.G. 1969. Long term effects of fertilizers and manure on soil and leaves of cotton in Nigeria. *Experimental Agriculture* 5: 241–247.
- Carter D.C., Harris D., Youngquist J.B. and Persaud N. 1992. Soil properties, crop water use and cereal yields in Botswana after additions of mulch and manure. *Field Crops Research* 30: 97–109.
- Chanterreau J. and Nicou R. 1994. *Sorghum*. London: Macmillan.
- Dennison E.B. 1961. The value of farmyard manure in maintaining fertility in northern Nigeria. *Empire Journal of Experimental Agriculture* 29: 330–336.
- De Ridder N. and van Keulen H. 1990. Some aspects of the role of organic matter in sustainable intensified arable farming systems in the West African semi-arid tropics (SAT). *Fertilizer Research* 26: 299–310.
- Draper N.R. and Smith H. 1981. *Applied Regression Analysis* (2nd edn). New York: Wiley.
- Gibberd V. 1995. Yield responses of food crops to animal manure in semi-arid Kenya. *Tropical Science* 35: 418–426.
- Greenland D.J. 1994. Soil science and sustainable land management. In: Syers J.K. and Rimmer D.L. (Eds) *Soil Science and Sustainable Land Management*, 1–15 (). Wallingford: CAB International.

- Harris F. and Yusuf M.A. 2001. Manure management by smallholder farmers in the Kano close-settled zone, Nigeria. *Experimental Agriculture* 37: 319–332.
- Ikombo B.M. 1984. Effects of farmyard manure and fertilizers on maize in semi-arid areas of Eastern Kenya. *East African Agricultural and Forestry Journal* 44: 266–274.
- Jones M.J. 1973. The organic matter content of soils of the savanna soils of west Africa. *Journal of Soil Science* 24: 42–53.
- Jones M.J. and Wild A. 1975. *Soils of the West African Savanna. Technical Communication No. 55*. Harpenden: Commonwealth Bureau of Soils.
- Laryea K.B., Andres M.M. and Pathak P. 1995. Long term experiments on alfisols and vertisols in the semi-arid tropics. In: Lal R. and Stewart B.A. (Eds). *Soil Management: Experimental Basis for Sustainability and Environmental Quality*, 267–292. Boca Raton: CRC Press.
- Micheni A.N., Kihanda F.M., Warren G.P. and Probert M.E. (In press). Testing the APSIM model with experimental data from the long-term experiment at Machang'a (Embu), Kenya. In: Delve R.J. and Probert M.E. (Eds). *Integrated Nutrient Management in Tropical Cropping Systems: Improved Capabilities in Modelling and Recommendations. Proceedings of an international seminar, Nairobi, 20–22 January 2003*, Canberra: ACIAR.
- Peat J.E. and Brown K.J. 1962. The yield responses of rain-grown cotton, at Ukiriguru in the Lake Province of Tanzania. II. Land resting and other rotational treatments contrasted with the use of organic manure and inorganic fertilizers. *Empire Journal of Experimental Agriculture* 30:305–314.
- Singh R.P. and Desai G.M. 1991. Farmers' fertilizer practices in the semi-arid tropics of India. *Progress Report 100, Economics Group, Resource Management Program, ICRISAT*. Patancheru, Hyderabad: International Crops Research Institute for the Semi Arid Tropics.
- Stern R.D., Knock J. and Burn R.W. 1990. *INSTAT*. Reading: Statistical Services Centre, The University of Reading.
- Tandon H.L.S. & Kanwar J.S. 1984. A review of fertilizer use research on sorghum in India. *ICRISAT Research Bulletin No. 8*. Patancheru, Hyderabad: International Crops Research Institute for the Semi Arid Tropics.
- Warren G.P., Muthamia J. and Irungu J.W. 1997. Soil fertility improvements under manuring in semi-arid Lower Embu and Tharaka-Nithi. In: Fungoh P.O. and Mbadi G.C.O. (Eds) *Focus on Agricultural Research for Sustainable Development in a Changing Economic Environment. Proceedings of the 5th KARI Scientific Conference, 14 to 16 October 1996, Nairobi*, 151–163. Nairobi: Kenya Agricultural Research Institute.
- Williams T.O., Powell J.M. and Fernandez-Rivera S. 1995. Manure utilization, drought cycles and herd dynamics in the Sahel: implications for cropland productivity. In: Powell J.M., Fernandez-Rivera S., Williams O. and Renard C (Eds) *Livestock and sustainable nutrient cycling in mixed farming systems of sub-Saharan Africa. Vol II: Technical Papers. Proceedings of an international conference held in Addis Ababa, Ethiopia, 22–26 November 1993*. Addis Ababa: International Livestock Centre for Africa.

Nutrient Recovery from Solid Waste and Linkage to Urban and Peri-Urban Agriculture in Nairobi, Kenya

Mary Njenga¹, Stephen Kimani², Dannie Romney³ Nancy Karanja^{1,4}

¹ Urban Harvest-CIP, ILRI campus P.O. Box 25171-00603 Nairobi, Kenya; ² Kenya Agricultural Research Institute, P.O. Box 57811-00200, Nairobi, Kenya; ³ International Livestock Research Institute, Box 30709 Nairobi, Kenya; ⁴ Soil Science Dept, University of Nairobi, Box 30197-00200 Nairobi, Kenya Email: m.njenga@cgiar.org; skimani@africaonline.co.ke; d.romney@cgiar.org; nancy.karanja@cgiar.org

Abstract

Community based composting practices were studied in Nairobi using a questionnaire, and the quality of composts produced characterised for nutrient and heavy metal contents. An inventory of the composting groups was made using existing databases. The quality of different manure types and their sources were also noted. The movement of Municipal Solid Waste (MSW) for composting and its outlets, as well as manures, were investigated through mapping of market and ecological chains. The study objectives aimed at documenting group dynamics in community based composting activities, quality of composts as influenced by different composting techniques and mapping of the movement of organic resources for soil fertility improvement.

It was established that composting practices used by the community-based organisations (CBO's), had an impact on the quality of the composts, which was found to be lower than the recommended international standards. The CBO's involved regard composting activities as a business enterprise from where their livelihood comes. Low market opportunities (low demand) for their product have hampered their growth and development.. It was also observed that there is an inflow of organic nutrients in the form of animal manure imported into the city from the arid and semi arid livestock producing areas, some of which are as far as 300 km from Nairobi. In contrast, there is a big challenge in the disposal of the same product within the informal settlement areas of the city

Key words: Community-Based Organisations (CBO's), compost quality, Municipal Organic Solid Waste (MOSW), resource flow, soil fertility

1. Introduction

Urban agriculture (UA) is defined as the production of food and non-food items through cultivation of plants, tree crop, aquaculture and animal husbandry within urban and peri urban-areas (Mougeot, 1999). It also involves processing and distribution of a diversity of foods and non-food products, using large amounts of human and materials resources, products and services found in and around those areas (Mougeot, 1999).

According to UNDP (1996a,b), it is estimated that 800 million people are engaged in Urban Agriculture (UA) worldwide. Of these, 200 million are considered

to be market producers, employing 150 million people full time. Globally, the number of urban farmers is expected to double from 200 million in the early 1990s to 400 million by 2005 (Mougeot et al., 1998). In Sub-Saharan Africa (SSA), UA is practised by 15% of households in Accra, 20% in Nairobi, 45% in Lusaka and 30% in Yaounde (Armar-Klemesum and Maxwell, 2000; Foeken and Mwangi 2000; Lee-Smith et al., 1987). In a broader perspective, estimates indicate that in 1993 between 15% and 20% of the world food was produced in urban areas (Mougeot, 1994). Other reports showed that urban farming provides for 70% of vegetables consumption in Dakar and 90% in Dar es

Salaam (Nugent, 2000). Livestock-keeping is also very common in urban centres and it has been reported that 17% of urban households keep livestock in Kenya and 80% in Zaria, Nigeria (Lee-Smith and Memon, 1994; Gefu, 1992). Urban agriculture contributes in no small measure to food security of many cities and as such it forms an important component of the urban food system which addresses the problems of the vulnerable groups (Haluna, 2002).

Municipal Solid Waste (MSW) management presents a major challenge for many Sub-Sahara African cities, where rapid growth, social and cultural change, widespread poverty, inadequate and weak local governance and limited financial resources all contribute to increasing pollution and waste disposal problems. Looking at a few selected urban centres in SSA, it is apparent that several million tonnes of waste are produced annually. For instance 635,000t are produced in Nairobi (JICA, 1997 Master Plan Study of Nairobi), 646,780t in Dar es Salaam (Kiongo and Amend, 1999), 313,900t (domestic) in Kumasi (Olufunke, 2003), and 765,040t in Accra (Etuah-Jackson et al., 2001). In Nairobi, 70% of the Municipal Solid Waste (MSW) is organic and it is estimated to contain 1.5% N, 1.5 %P and 2.5% K (NRC, 1996 and World Bank, 1997), which translates to about 2,223t N and 2,223t P and 3,700t K if made into compost, annually.

The problem of solid waste recycling can no longer be treated lightly especially in view of its many inherent advantages, which are being tapped increasingly even by the developed nations of the world. Large scale composting has been difficult to adopt in developing countries. For instance composting plants in Ibadan, Nigeria and Accra, Ghana, have been found not to be able to meet the demand of compost, too expensive to maintain, affected by government instability, causing environmental problems due to large heaps of waste being dumped at the site (Agbola, 2001; Etuah-Jackson et al., 2001).

These nutrients could be exploited through appropriate technologies for production of bio-fertilizer (compost) and could be used to bridge the nutrient deficiencies commonly found in tropical soils especially in SSA. Pathogens, attraction of disease vectors by heaped compost, injuries from non-biodegradable fragments and heavy metal contamination are four main sources of health risks in reuse of urban organic solid waste products, which need to be considered in compost production as indicated by Lock and De Zeeuw (2003).

The study sort to documenting group dynamics in community based composting, document, quality of

composts as influenced by different composting techniques, and, map the movement of organic resources for soil fertility improvement.

2. Materials and methods

A survey was conducted between March and December 2003 by Urban Harvest, International Livestock Research Institute (ILRI), World Agroforestry Centre formally International Centre for Research in Agroforestry (ICRAF), which are centres of the Consultative Group on International Agricultural Research (CGIAR), in partnership with Kenya Agricultural Research Institute (KARI) and Kenya Green Towns Partnership Association (KGTPA), which is a Non-Governmental Organisation (NGO). Ten livestock-producing areas within Nairobi were selected using information generated from a scoping study in Nairobi by Ishani et al. (2002). Arid and Semi Arid Lands (ASAL) were chosen for the interviews as known sources of animal manure and the location of which was done by the Department of Agriculture and Livestock Development, Ngong division. Composting groups were identified using a database compiled by WasteNet in a study funded by International Development Research Centre (ITDG-EA, 2003, www.wastenet.or.ke). Through this database, six CBO's involved in composting were identified. Five more were added through contacts with the former groups of the six samples. One composting group outside Nairobi, which concentrates on mining municipal dumpsite, was chosen with the aim to analyse health risks with this type of compost. Locating all the composting sites was done by Kenya Green Towns Partnership Association.

Primary data were collected using individual and group open and semi-structured questionnaires. Focus Group Discussions (FGD's) brought together farmers, non-farmers and CBO's involved in waste management. Inter-and intra-urban resource flow patterns for organic waste and livestock manure were mapped, including backward and forward linkages, which were established through interviews, and road drives to the sites.

The respondents in this study comprised 11 composting groups, one crop farming CBO, one mixed farming CBO, one livestock keeping CBO, three manure transporters, six manure traders, two landscapers and 22 individual livestock manure producers. Fourteen compost and nine animal manure samples were collected from individual farmers and groups

turning, temperatures and duration of time the materials took before maturity. These activities may have had an influence on the factors that affect biological decomposition process such as micro-organisms and invertebrates, oxygen supply and aeration, pH, Nitrogen conservation and moisture content and hence the resultant quality. There is therefore need for clear monitoring of these factors in community based compost production.

3.2. Resource flows inform of organic waste

Eleven composting CBO's in Nairobi sourced 2,500t of Municipal Organic Solid Waste annually from vegetable markets, households, food kiosks and hotels, dumpsites and agro-industries, which constituted 1% of the organic waste produced in Nairobi. Nine CBO's sourced organic materials within a radius of 0.05–9 km, thus the need to carry the resource through vehicles or manually by using carts or wheelbarrows.

After the organic materials were turned into compost, the product was sold on site. The buyers include plant nurseries, ornamental gardens, landscapers or estate developers from the urban areas of Nairobi, organisations and institutions in urban and peri urban Nairobi within a distance of 0.01–50 km, large horticulture farms in the rural areas mainly from the Rift Valley Province. Compost was transported using vehicles, bicycles or manually using wheelbarrows or carts. A total of 253t, or 40% of the total compost produced, is traded annually at a price of 67–133 US\$ per tonne. Animal manures were sourced from Arid and Semi Arid Lands (ASAL) Kajiado district a distance of between 60–100 kms at a cost of 5–6 US\$ per tonne and traded in the city at a price of 14–24 US\$ per tonne by roadside vendors, transporters or landscapers. Manure was transported from the source using lorries. The main clients include plant nurseries, ornamental gardens, landscapers or estate developers from the urban areas of Nairobi and crop farmers from urban and peri-urban Nairobi. Most of the manure only passes through the city and ends up in the high potential rural areas within 150 km radius of Nairobi where demand is never met despite the high prices.

The survey established that compost making as a business enterprise is experiencing many challenges, such as lack of awareness of compost sources and its usefulness as an alternative fertilizer, fear from potential clients due to health risks, lack of knowledge on

compost making leading to low quality compost products. Other factors lowering the demand of compost by urban farmers are insecurity of land tenure, use of wastewater as a source of soil nutrients, high cost of compost (67–133 US\$ per tonne) when compared to animal manures, which most farmers are familiar with, and conventional inorganic fertilizer. The other factor limiting development of the activity is that the quality of compost was not known. This applies to the potential users as well as to the producers. Furthermore, over 60% of manure produced in the many urban informal settlement areas is thrown away and only less than five percent is traded. This was associated to its heavy weight and its 'semi-decomposed state'. In contrast, the peri-urban areas manure production does not meet its demand and farmers supplement with mineral fertilizers.

4. Conclusions and recommendations

This study shows that composts from urban and peri-urban Nairobi are good quality organic fertilizers, based on the C:N ratio measurements and levels of other nutrients such as K, Mg and even P. However, the quality could be considerably improved through supplementation and support programmes that help groups to develop consistent quality controls. Since only 11 CBO's were visited, there is need to conduct further work on composts from urban and peri-urban Nairobi and other cities in Kenya, particularly to explore methods of product improvement and market access, through action research.

There is a need to further explore the various composting practices and associated health risks so as to come up with best approaches of exploiting MOSW for production of bio-fertilizers (compost) that are needed to alleviate nutrient deficits in the farming systems in Kenya. The National Environmental Management Authority (NEMA) should coordinate a review of the World Health Organization (WHO) and World Bank standards on standards on heavy metals and nutrients so as to identify appropriate standards for national and regional conditions.

There is also need to address the urban land use policy issues for the incorporation of urban and peri-urban agriculture, which would enhance investment in soil fertility improvement. Further research is also required in the microeconomics of compost production, so as to arrive at an economically viable product.

Acknowledgements

The authors would like to thank Kuria Gathuru for the important role that he played in linking the research team with the community. We also thank Wastenet for availing the database of CBO's handling waste in Nairobi. The input of Sammy Carsan and Will Frost both of World Agroforestry Centre (formally International Centre for Research in Agroforestry (ICRAF) in mapping out resources flows through the market and ecological chains is highly appreciated. The work done by Kamau of the Ministry of Agriculture and Livestock Development Ng'ong division is highly appreciated. We also acknowledge the technical backstopping by Lee-Smith Diana on Urban and Peri-urban Agriculture issues. A lot of thanks go to World Bank for its financial support through Urban Harvest, which enabled the five institutions to undertake the research.

References

- Agbola T. 2001. Turning Municipal Waste into Compost: The Case of Ibadan (2001) In: Drechsel P. and Kunze D. (eds) Waste Composting for Urban and Peri-urban Agriculture: Closing the Rural-Urban Nutrient Cycle in Sub-Saharan Africa, 69 pp.
- Anderson J.M. and Ingram J.S.I. 1993. Tropical Soil Biology and Fertility. A Handbook of Methods. C.A.B. International. Wallingford, U.K. Bull. No. 9. The Sulphur Institute, Washington, U.S.A.
- Armar-Klimesum M. and Maxwell, D. 2000. Urban Agriculture as an Asset Strategy, Supplementing Income and diets.
- Etuah-Jackson, Klaassen W.P. and Awuye J.A. 2001. Turning Municipal Waste into Compost: The Case of Accra. In: Drechsel P. and Kunze D. (eds) Waste Composting for Urban and Peri-urban Agriculture: Closing the Rural-Urban Nutrient Cycle in Sub-Saharan Africa. 84 pp.
- Foeken D. and Mwangi A. (2000). Increasing Food security through Urban Farming in Nairobi. In Bakker, N., Dubbeling, M., Gundel, S., Sabel-Koschella U. and De Zeeuw h. (eds) Growing Cities, Growing Food. Urban Agriculture on the Policy Agenda.
- Gefu J.O. 1992. Part-time farming as an urban survival strategy: a Nigerian case study. In: Baker J. and Pedersen P.O. The rural-urban interface in Africa: expansion and adaptation (Scandinavian Institute of African Studies, Stockholm), pp. 295-302.
- Haluna S. 2002. The Contribution of Urban Agriculture to Household Food Security in the Tamala Municipality; B.Sc. Project Report.
- Ishani Z., Gathuru P.K. and Lamba D. 2002. Scoping Study of Urban and Peri-Urban Poor Livestock Keepers in Nairobi. Mazingira Institute
- ITDG-EA (2003) Nairobi Waste Management Partners Database. www.wastenet.or.ke
- Kiongo S. and Amend. J. 1999. Linking (Peri)Urban Agriculture and Organic Waste Management in Dar es Salaam. Paper presented at an International IBSRAM-FAO Workshop on Urban and Peri-Urban Agriculture, Accra, Ghana 2-6 August 1999.
- Lee-Smith D., Manundu M., Lamba D. and Gathuru P.K. 1987. Urban Food Production and the Cooking Fuel Situation in Urban Kenya. Mazingira Institute
- Lee-Smith D. and Memon P.A. 1994. Urban Agriculture in Kenya. In: Cities feeding People; an examination of urban agriculture in East Africa. International Development Research Centre. Ottawa, Canada. p. 146.
- Lekasi J.K., Tanner J.C., Kimani S.K. and Harris P.J.C. 2002. Cattle manure quality in Maragua District, Central Kenya: effect of management practices and development of simple methods of assessment. Agriculture, Ecosystems and Environment 94: 289-298.
- Lock K. and De Zeeuw H. 2003. Health and Environmental Risks Associated with Urban Agriculture. A Paper presented in a workshop 'Health Risks and Benefits of Urban Agriculture and Livestock Farming in Sub-Saharan Africa' held in June 9-12, 2003 in Nairobi-Kenya.
- Mougeot L. 1994. 'African City Farming from World Perspective'
- Mougeot L., Faruqui N., Smith O., Wilson B and Hovorka A. 1998. 'Programme Initiative - Program Summary 1997-2000', CFP Report Series 22, IDRC, Ottawa
- Mougeot L. 1999. Urban Agriculture: Definition, Presence, Potential and Risks, Main Policy Challenges. Paper presented at an international workshop on Growing Cities Growing Food: Urban Agriculture on the Policy Agenda, La Habana, Cuba October 11-15: 1999
- National Research Council (NRC) 1996. Use of Reclaimed Water and Sludge in Food Crop Production. Washington, D.C. National Academy Press.
- Nugent R. A. (2000) The Impact of Urban Agriculture on the household and local economies. Paper presented at an International Workshop on Growing Cities Growing Food: Urban Agriculture on the Policy Agenda, La Habana, Cuba October 11-15: 1999
- Olufunke C. 2003. Co-composting of Faecal Sludge and Solid Waste for Urban and Peri-urban Agriculture in Kumasi, Ghana
- Statistical Analysis Systems (SAS) of SAS Institute inc. 1998. SAS Users Guide, Cary, NC. USA.
- UNDP 1996a. Publication Series for Habitat 11 Vol 1
- UNDP 1996b. Publication Series for Habitat 11 Vol 11
- Walkley A. and Black I.A. 1934. An examination of Degtjareff method for determining soil organic matter and proposed chromic acid titration method. Soil Sci., 37: 29-38.
- World Bank. (1997) The Use of Compost in Indonesia: Proposed Compost Quality Standards. Infrastructure Operations, Country Department III, East Asia and Pacific Region, Washington, D.C., U.S.A. June.

Optimising crop productivity in legume-cereal rotations through nitrogen and phosphorus management in western Kenya

Kihara J.^{1*}, Kimetu J.M., Vanlauwe B., Bationo A., Waswa B. and Mukalama J.

*The Tropical Soil Biology and Fertility Institute of CIAT, P.O Box 30677, Nairobi, Kenya; * Corresponding author.*

Telephone: +254-20-524759, Fax: +254-20-524763, Email: J.Kihara@cgiar.org (J. Kihara)

Abstract

Combined application of organic resources and mineral inputs is integral to sustainable soil fertility management but in-situ production of adequate organic matter is often limited by P availability. An experiment was set up at Nyabeda in Western Kenya aimed at (1) quantifying the contribution of herbaceous and grain legumes to nitrogen supply in a cereal-legume rotation system and (2) quantifying the impact of targeting phosphorus (P) to certain phases of the rotation on overall maize grain yield. In this split-split plot experiment, *Mucuna pruriens* was used as the herbaceous legume while soybean was used as the grain legume. Results obtained in the two seasons of the study indicated that the use of either mucuna or soybean as previous crop significantly increased maize grain yield with or without the addition of nitrogen fertilizer. More than 5 tons ha⁻¹ of maize grain yield was realised in season two following the addition of phosphorus fertilizer at both season one and season two compared to about 3 tons ha⁻¹ of maize grain yields obtained when no P was added. It could be concluded that in this region, the addition of P fertilizer is an integral management option to ensure optimal utilization of the nitrogen fixed by the legume crop. Using P during the legume season may be sufficient to supply P requirements to the succeeding cereal crop. Also, applying P to the mucuna or soybean legume crop was not any different from applying it both to the legume and cereal crops indicating that farmers can save labour and cash by applying P only to the legume. The good performance of maize planted after mucuna was an indication that mucuna could be used by farmers in the region as an N source (Nitrogen Fertilizer Equivalency (NFE) >100 kg N ha⁻¹) thus reducing cost of buying N fertilizers. Although soybean showed a lower NFE of 40 kg N ha⁻¹, it had higher economic benefits and could thus be more acceptable to the farmers. These findings could be confirmed by using more than two cereals and legume rotation cycles

Key words: Mucuna, Nitrogen fertilizer equivalence, Phosphorus, Rotations, soybean

Introduction

Nitrogen and phosphorus are the most limiting nutrients for crop production in sub-Saharan Africa (SSA) (Sanchez, 1976; Bationo et al., 2003; Gikonyo and Smithson, 2003). Inorganic fertilizers can be applied to increase production but these often cause problems when applied alone and are also not affordable to a large segment of small-scale farmers (McIntire and Fussel, 1986). Combined application of mineral fertilizers and organic resources has been proposed as an

appropriate strategy to ameliorate soil fertility decline and improve productivity. However, procuring a sufficient amount of organic matter of a desired quality is very often a problem faced by farmers and researchers. High quality organic residues from mulches and green manure legumes of sufficient quantity could increase subsequent cereal production through their N input. In-situ production of organic matter, though an attractive alternative to biomass transfer that harvests the organic resources from other sites within or outside the farm, may often be limited by the availability of P. Opting for

legumes during the organic resource production phase and targeting P application has the potential to increase legume efficiency in accessing and solubilising P and enrich the soil with N through biological N₂ fixation. Application of P could therefore enable legumes to benefit by maximally exploiting the advantage of their biological nitrogen fixation mechanism. By targeting P also, farmers could save cash by applying only to certain phases of the rotation and not year-to-year, as has often been the case for many farmers.

Herbaceous or grain legumes usually leave substantial amounts of N in the soil after harvest. Senescing leaves could contain substantial amounts of N and up to 90 kg N ha⁻¹ can be added in leaf fall (Sakala et al., 2002). When left to grow to maturity, however, harvesting the seeds may substantially reduce the net N input into the soil. Currently, dual-purpose germplasm for cowpea and soybean for example, is available and produces substantial amounts of haulms besides grains and has a relatively low N harvest index (Sanginga et al., 2001). As such, a net N input into the soil can be expected as opposed to 'traditional' grain legume germplasm with large N harvest index taking more N away during grain harvest and resulting in a negative net N input. Besides fixing N, some workers have attributed the positive effects of rotations to the improvement of soil biological and physical properties and the ability of some legumes to solubilise occluded P and highly insoluble calcium bounded phosphorus by legume root exudates (Hoshikawa, 1991; Gardner et al., 1981; Arhara and Ohwaki, 1989). Other advantages of crop rotations include soil conservation (Stoop and Staveren, 1981), organic matter restoration (Spurgen and Grissom, 1965) and pest and disease control (Sunnadurai, 1973; Kimetu et al., 2003). These benefits are often summarized as non-N benefits. The effect of a legume on a succeeding cereal crop is often expressed as its N equivalent. One needs to take into account, however, that the processes mentioned above may also lead to better utilization of legume or fertilizer N although the improved yields are not necessarily an improvement of N supply. Rotating cereals and legumes is a cheaper means of improving soil fertility and system productivity (Bagayoko et al., 1996; Bationo et al., 1998; Klaij and Ntare, 1995).

Legumes usually require a sufficient amount of P for the legume-Rhizobium symbiosis to function optimally while cereals require substantial amounts of N and P for optimum growth. Moreover, as P usually shows substantial residual effect, targeting the P in legume-cereal rotations to a specific phase of the

rotation may significantly alter the growth of both components.

The overall aim of the study was to quantify the contribution of *Mucuna pruriens*, a herbaceous legume, and soybean, a grain legume, to N supply and quantify the impact of targeting P to certain phases of the rotation on the overall yield. The study sought to (i) determine the nitrogen (N) fertilizer equivalency values of mucuna and soybean biomass and (ii) Optimise on the use of mineral phosphorus (P) inputs in legume-cereal rotations.

Materials and methods

Site description

Nyabeda, a site in western Kenya that is proven responsive to N and P and not infested with striga, was selected for the study. The site was homogeneous both in terms of soil characteristics and previous land use and had not received N or P fertilizer at least 2 years prior to trial establishment. Soil sampled before treatment application gave available N content of 26.3 mg N kg⁻¹.

Treatment structure

Table 1 shows treatment structure of the design used. The plots were 12 by 6 m and each treatment was replicated three times. The treatments indicated with '-/+N' were split into 2 subplots, 6 by 6 m, one receiving 0 kg N ha⁻¹ and the other 45 kg N ha⁻¹. The plots in treatments indicated +N(4) were split into 4 subplots (each 6 by 3 m) to accommodate an N response curve using N application rates of 0, 30, 60, 90 kg N ha⁻¹. Urea was used as the inorganic source of N while TSP was the inorganic source of P.

Legume selection

Mucuna pruriens (white seeded) was used as the herbaceous legume ('Herb L') based on its adaptability to the agro-ecozone and its potential in biomass production while Soybean was used as the grain legume ('Grain L') following its potential in biomass and grain production and its soil fertility restoration ability through N fixation. Also, soybean has been at the screening stage in western Kenya and preliminary indications have shown

Table 1. Treatment structure targeting P in legume-cereal rotations

Treatment	Season 1		Season 2	
	Crop	Fertilizer	Crop	Fertilizer
1	Cereal	-N; +P	Cereal	-N; +P
2	Cereal	-N; +P	Cereal	+N(4); +P
3	Cereal (contains control)	-N; -P	Cereal	+N(4), -P
4	Cereal	-N; +P	Cereal	+N(4), -P
5	Cereal	-N; -P	Cereal	+N(4); +P
6	Soybean	-N; +P	Cereal	-/+N; +P
7	Soybean	-N; -P	Cereal	-/+N; -P
8	Soybean	-N; +P	Cereal	-/+N; -P
9	Soybean	-N; -P	Cereal	-/+N; +P
10	Mucuna	-N; +P	Cereal	-/+N; +P
11	Mucuna	-N; -P	Cereal	-/+N; -P
12	Mucuna	-N; +P	Cereal	-/+N; -P
13	Mucuna	-N; -P	Cereal	-/+N; +P

a very high demand from the farmers. The maize variety used was Hybrid 513 that is suitable for low altitude zones.

Management of the experiment

Land preparation followed farmers' practices. All aboveground fallow biomass was removed from the site before trial establishment. The experiment was kept weed-free as much as possible. Test strips of 5 border rows to which N and P fertilizer were applied surrounded the experimental site to protect against damage and border effects.

Phosphorus fertilizer, applied at 50 kg P ha⁻¹, was banded within the line. N fertilizer was spot applied and incorporated at planting. Since the focus of the trial was only N and P, all the treatments received a basal application of 60 kg K ha⁻¹ as Muriate of potash before the start of each season.

The experiment was conducted for two seasons with total seasonal rainfall of 655 mm in the first season and 910 mm in the second season. Season one (the short rains season) was from September 2001 to February 2002 while season two (the long rains) was from March 2002 to September 2002.

Sampling and analyses

Maize was harvested from net plots at maturity leaving 2 border rows (0.25 m spacing) on *either side and* one row (0.75 m spacing) from the other ends to eliminate edge effects. Thus the harvest area was

49.5 m², 22.5 m² and 9 m² from entire plots of 72 m², 36 m² and 15 m² respectively. Ears were separated from the stover and the fresh weight of each determined. A sub sample of 10 plants and 10 ears was used, and the fresh weights taken before air-drying to constant weight for dry weight measurements. Grains were first separated from the core and their separate dry weights determined. The total yields of grain, stover biomass and core were determined using the formula:

$$\text{Yield (t/ha)} = \text{net plot FW} * \text{ssDW} / \text{ssFW} * 10000 / A,$$

Where: net plot FW is fresh weight (kg) from net plot, ssDW is dry weight (g) from sub sample, ssFW is fresh weight (g) from sub sample and, A is harvested net plot area (m²).

Legume biomass was sampled at peak biomass using two 1 m² quadrants diagonally across all the legume plots. All aboveground biomass was cut and weighed before air-drying and taking the dry weight measurements. Assessment of nodules at peak biomass using the quadrants was done by gently removing the legume root system with a spade to the depth where nodule formation ceases. After gently removing the attached soil and washing the roots on a 0.5 mm sieve, the nodules were counted and their fresh and dry weights taken. At maturity, all the biomass, pods and grains from the entire net plot were measured for fresh and dry weights. A similar formula to the one for calculating maize yield was used to determine yield from mucuna and soybean. After a legume crop, the legume residues were left on the field.

Determining nitrogen fertilizer equivalencies (NFE) of mucuna and soybean

Treatments of continuous cereal (treatments 2, 3, 4, and 5) were each split into four subplots and each subplot applied with four different N fertilizer rates (0, 30, 60, and 90 kg ha⁻¹). The yields obtained from the N rates were used to plot an N response rate against which the yields obtained after mucuna and soybean were compared.

Determining economic benefits of mucuna and soybean practises

All the legume treatments with zero N were used to do a partial economic analysis as shown in Table 6. With TSP having 46% P, 108 kg of TSP supply 50 kg P ha⁻¹ for each season and 216 kg of TSP where P was applied for both seasons. The legume treatments used were averaged for 0 N and 45 N giving 22.5 kg N ha⁻¹ for the values used and this required urea at 54 kg ha⁻¹. Crop value was calculated using yield data for both seasons; maize + Maize for the control and Legume + maize for the other treatments. The value of mucuna was zero since it does not have a crop value presently in this region. The price of maize was 9 USD for a 90 kg bag in 2002. We have also considered the

price of maize according to governments new directive (15 USD per 90 kg bag in 2005).

Results and discussions

Maize grain yield as affected by target P and N rates

Maize grain yields obtained from continuous maize treatments showed that treatments where no P was applied had the lowest yield (Table 2). In treatments where P was applied, lower yields were observed when the P was applied only during season one compared to its application to either both seasons or during the second season only, although the difference was not significant at $p = 0.05$. On average, applying P only to season 2 increased average maize grain yields by 954 kg ha⁻¹ above treatments where P was applied during the previous season only. During season 1, the grain yield difference with or without P was only 137 kg ha⁻¹ due to the low seasonal rainfall in that season that also led to low overall yields (between 1490 and 1350 kg ha⁻¹ with and without P respectively) (data not included). Applying P in both seasons gave the highest yields at 30, 60, and 90 kg N ha⁻¹ and still showed good response to N application indicating the importance of P in this soil for better crop growth and N use efficiency. As shown in Table 2 and 3, there was no response to N without application of P. Good crop response was

Table 2. Effect of P and N on maize grain yield in Nyabeda, western Kenya, in 2002

Season 1	Season 2	Grain (kg ha ⁻¹)				
Treatment	Treatment	0N	30N	60N	90N	Average
No P	No P	2545	2363	2501	2372	2445
With P	No P	3573	3942	4460	4193	3964
No P	With P	5455	4616	4325	5278	4918
With P	With P	4820	4991	5252	6080	5285
<i>SED</i>		1020.2	1047.2	981.8	1085.8	

Table 3. Effect of P and N on maize stover yield in Nyabeda, western Kenya, in 2002

Season 1	Season 2	Stover (kg ha ⁻¹)				
Treatment	Treatment	0N	30N	60N	90N	Average
No P	No P	2212	2833	3376	2536	2739
With P	No P	3807	3997	4415	4240	4115
No P	With P	4464	4996	3795	4286	4385
With P	With P	4754	5529	5535	5284	5276
<i>SED</i>		1298.7	927.1	611.7	438.5	

observed when 50 kg P ha⁻¹ was applied either in season one or two or during both seasons suggesting the need to apply P at least in one of the seasons.

Maize grain yield in Mucuna-maize, soybean-maize rotations as influenced by target P

The contribution of mucuna and soybean to maize grain yield is shown in Table 4. The lowest significant yields ($p = 0.05$) were observed without application of P for both mucuna and soybean treatments. There was no significant difference in maize grain yield of the succeeding crop when P application was targeted either to the first, second or both seasons.

With mucuna as the previous crop, P application was found to significantly increase maize grain yield in both N and no N treatments. Between 4881 and 5455 kg ha⁻¹ of maize grain yield was realised with the addition of P at either season compared to 2799 to 3219 kg ha⁻¹ of maize grain yields obtained when no P was added (Table 4). Treatments with N and no N were the same for mucuna suggesting that mucuna as a previous crop could supply all the N requirement of the succeeding crop. For soybean, treatments that received P in the legume phase showed some response to N while those without P applied during the legume phase did not suggesting contribution of other factors besides N supply. This further shows that the cereal crop does not effectively use the N contributed by the legume in the absence of P. The relatively lower maize response after mucuna compared to soybean without P could be an indication of low efficiency in mucuna to fix

N in the absence of P compared to soybean. Further investigation is necessary to find out the differences between mucuna and soybean in P solubilization especially when P is not supplied. Vanlauwe et al. (2000) showed that mucuna significantly enhanced the Olsen-P content of soil after rock phosphate (RP) addition compared to the Lablab or maize treatments on the 'plateau' and 'valley' fields in Guinea and Nigeria but the effect depends on relative initial Olsen-P content of the soil.

Nitrogen fertilizer equivalencies of mucuna and soybean

Maize grain of upto 5150 kg ha⁻¹ was produced after mucuna compared to 4200 kg ha⁻¹ following soybean with both legumes receiving 50 kg P ha⁻¹ (Figure 1). As already shown in Table 4, these yields were not different from those from the legume-cereal rotations with P application in both seasons. A response curve using continuous maize at different N application rates and 50 kg P ha⁻¹ applied during the first season showed a Nitrogen Fertilizer Equivalence (NFE) of 40 kg N ha⁻¹ for soybean and NFE of >100% for mucuna (Figure 1). If fertilizer equivalence for mucuna is determined using an N response curve in treatments that received P in both seasons (See data in Table 2), an NFE of about 50 kg N ha⁻¹ would be obtained. This shows that NFE values reported depend on P fertilization and may differ from one site to another depending on the level of P limitation. Considering such a response curve that uses treatments where P was applied in

Table 4. Effect of legume as previous crop and targeting P on maize grain yield in Nyabeda, Western Kenya

Season 1	Season 2	Grain Yield (kg ha ⁻¹)		Stover Yield (kg ha ⁻¹)	
		No N	With N	No N	With N
Mucuna -P	Cereal -P	3219	2766	3124	2206
Mucuna +P	Cereal -P	5137	5194	4976	5287
Mucuna -P	Cereal +P	5455	5270	4371	5215
Mucuna +P	Cereal +P	5003	4881	4620	5091
<i>SED</i>		821	768.2	680.7	1233.3
Soybean -P	Cereal -P	4009	3425	3976	3149
Soybean +P	Cereal -P	4213	5032	4314	4773
Soybean -P	Cereal +P	4872	3658	3956	3210
Soybean +P	Cereal +P	4206	4954	3627	5029
<i>SED</i>		1197.9	803	715.4	763.6

For P*N mucuna had SED of 530.6 and 989.4 for grain and stover respectively while soybean had SED of 594.1 and 585.5 for grain and stover respectively.

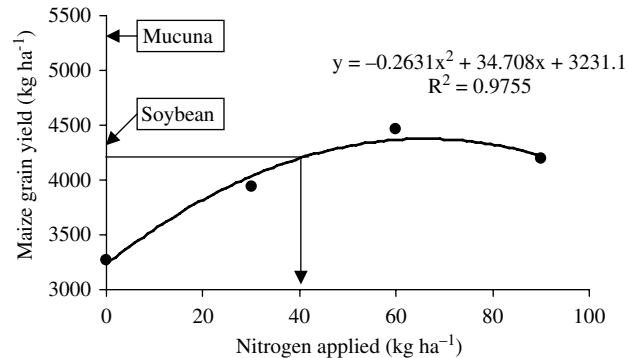

Figure 1. Response curve for legume-cereal rotation at Nyabeda, Western Kenya.

both seasons shows that with adequate supply of P, favourable response to N fertilizer will be found beyond 90 kg N ha⁻¹, the highest rate used in the experiment. Although this two-season data shows a very high NFE of mucuna compared to soybean, benefits of soybean may build up in subsequent seasons to match the effect of mucuna and this will be evaluated in this continuing experiment.

Legume grain and biomass yield and nodulation

Figure 2 shows grain and biomass yields as well as total number of nodules obtained from mucuna and soybean with and without P application. Use of P increased mucuna grain and biomass yields by 24 and 32% respectively and almost doubled that of soybean (67% grain and 83% biomass yield increase). Legumes require P for maximum growth and N fixation and their effectiveness in soil improvement can be hindered by P deficiency (Carsky et al., 2001). Using an average of 3.61% N in mucuna leaves and stems (Cobo-Borrero,

1998), incorporation of mucuna biomass grown with addition of P would result in 130 kg N ha⁻¹ compared to about 100 kg N ha⁻¹ without addition of P. These values agree with the findings of Carsky 2001.

The number of nodules at peak biomass was also influenced by application of P. Treatments with mucuna that also received P for example increased nodules by 63% while applying P to soybean increased nodules by 50% (Figure 2). Phosphorus is known to increase the efficiency of legumes to fix N and is needed by the legumes for structural purposes. For example, Lungu and Munyinda (2003) found both the biomass and grain yields of groundnut, cowpea and soybean to more than double following the application of P. Also, Besmer et al. (2003) found applications of P in soils in south-western Zimbabwe to significantly increase nodule mass, aboveground biomass and total N in residues of groundnut (*Arachis hypogaea* L.), lablab bean (*Lablab purpureus*) and pigeon pea (*Cajanus cajan* (L.) Millsp.). These findings agree with Carsky et al. (2001) who noted that phosphorus deficiency can limit nodulation of legumes.

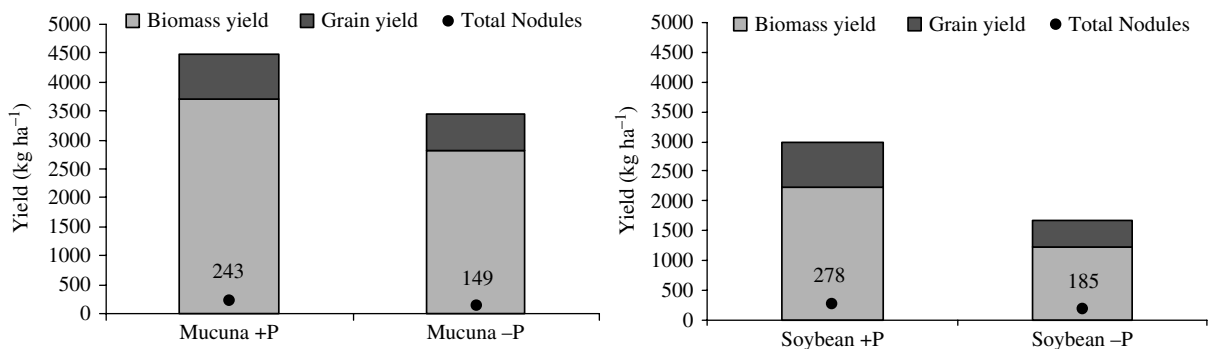

Figure 2. Legume grain and biomass yield and total nodules (per m²) during season one.

Yield advantage of mucuna and soybean

Regardless of the treatment, using either mucuna or soybean as the previous crop considerably increased maize grain and stover yield of the succeeding maize crop. Without P application, soybean increased maize grain yields by 1170 kg ha⁻¹ above the maize-maize control while mucuna increased the yield by 450 kg ha⁻¹ (Table 5). Highest maize grain yield advantages of 2600 kg ha⁻¹ were observed with mucuna when P was either applied to the legume phase or to the cereal production phase. Rotating soybean and maize and applying P in one phase of the rotation may be sufficient to increase farmer productivity above continuous maize cultivation with year after year application of mineral fertilizers. The productivity is greatly

Table 5. Yield advantages of maize grain and stover using legume and targeting P in Nyabeda, western Kenya, in 2002

	Grain* advantage (kg ha ⁻¹)	Stover* advantage (kg ha ⁻¹)
Mucuna +P; Cereal +P	2397.0	2643.5
Mucuna +P; Cereal -P	2620.1	2919.5
Mucuna -P; Cereal +P	2607.6	2581.0
Mucuna -P; Cereal -P	447.3	453.0
Soybean +P; Cereal +P	2035.0	2116.0
Soybean +P; Cereal -P	2077.4	2331.5
Soybean -P; Cereal +P	1877.5	1371.0
Soybean -P; Cereal -P	1172.3	1350.5

Compared to 2545 and 2212 kg ha⁻¹ of maize grain (see Table 2) and biomass (see Table 3) yields respectively from the control * yield used was average of both N and no N treatments.

Table 6. Full economic analyses of the legume-cereal options

	Control	Mucuna				Soybean			
		+P; +P	+P; -P	-P; +P	-P; -P	+P; +P	+P; -P	-P; +P	-P; -P
Crop value (2002)	38950	49420	51651	51526	29923	61040	55364	59465	46313
TSP	0	6480	3240	3240	0	699840	349920	349920	0
Urea	0	1836	1836	1836	1836	1836	1836	1836	1836
Labour*	32800	30300	30300	30300	30300	34300	34300	34300	34300
Benefit	6150	10804	16275	16150	-2213	-674936	-330692	-326591	10177
B/C ratio	0.2	0.3	0.5	0.5	-0.1	-0.9	-0.9	-0.8	0.3
Crop value (2005)	50635	64246	67147	66983	38900	74780	69231	72733	57465
TSP	0	4550	2275	2275	0	4550	2275	2275	0
Urea	0	2160	2160	2160	2160	2160	2160	2160	2160
Benefit	17835	27236	32412	32248	6440	33770	30496	33998	21005
B/C ratio	0.5	0.7	0.9	0.9	0.2	0.8	0.8	0.9	0.6

*Labour is constant for both 2002 and 2005.

increased when legume produce and possible contribution to the livestock system is taken into account. Vanlauwe et al. (2001) in summarizing legume contribution to cereal yield in West Africa observed that mucuna created large rotational benefits of between 50–350% depending on the fertility status of the soils. Friesen et al. (2003) reported that legume rotations in East Africa consistently produced higher maize grain yield (1.5–3.5 t ha⁻¹ or 27–134%) than unfertilised maize in monocrop.

Partial economic benefit analysis of legume-cereal rotation technologies

There was more benefit and a higher benefit/ cost ratio with soybean as the previous crop compared to Mucuna (Table 6) resulting from the additional benefit of soybean grain. The most profitable practise is growing maize after soybean with P application during the cereal season. Although soybean system required an extra weeding costing kshs 4000 (USD 55), it still recorded more benefits than mucuna system because of its grain value. With this practise, a farmer could earn kshs 68000 (USD 900) when using his own labour and kshs 34000 (USD 450) when sourcing labour externally (Table 6).

Cost of urea was kshs 34 kg ha⁻¹ but price in 2005 was Kshs 40 kg⁻¹, Price of TSP was 30 in 2002 and 35 in 2005. The price of maize was kshs 10 kg⁻¹ in 2002 and 13 kg⁻¹ in 2005 while soybean has been constant at Kshs 20 kg⁻¹ for the period. Initial ploughing was Kshs 5400, two weeding total Kshs 8000 (only one weeding for mucuna crop), harvesting at Kshs 3000 and Kshs 1500 for top dressing in the legume plots.

Conclusions

With either mucuna or soybean as previous crop, there is no need to apply mineral N to the succeeding cereal crop. Inclusion of legumes in rotation with cereals can be a solution to the problem of N deficiency that limits cereal production in western Kenya.

The application of mineral P in the soils of western Kenya is essential for a good legume and subsequent cereal crop harvest. The use of P during the legume phase will increase not only the productivity of the legume crop but will also lead to significant residue effects on the succeeding cereal crop. While the study shows strongly that a cereal crop after mucuna with P should not be applied with P, such a crop could still require P if the previous crop is soybean. Since inorganic P is expensive, the potential of using inoculants to enhance the ability of soybean to utilize P available in the soil in this region need further testing with different levels of mycorrhizae.

Acknowledgement

The authors would like to acknowledge Rockefeller foundation for supporting TSBF to do this work. The authors also acknowledge James Kinyangi and Catherine Gachengo for their involvement and commitment to this work during its initial stages.

References

- Arhara J. and Ohwaki Y. 1989. Estimation of available phosphorus in vertisol and alfisol in view of root effects on rhizosphere soil. In XI Colloquium Wageningen, Holland
- Bagayoko M., Mason S.C., Traore S. and Eskridge K.M. 1996. Pearl millet/cowpea cropping systems yield and soil nutrient levels. *African Crop Sci. J.* 4: 453–462
- Bationo A., Kimetu J., Ikerra S., Kimani S., Mugendi D., Odeno M., Silver M., Swift M.J. and Sanginga N. 2004. The African Network for Soil Biology and Fertility: New Challenges and Opportunities. In: Bationo A. (Ed.), *Managing nutrient cycles to sustain soil fertility in sub-Saharan Africa*. Academy Science Publishers, Nairobi, Kenya. pp 1–23
- Bationo A., Lompo F. and Koala S. 1998. Research on nutrient flows and balances in West Africa: State-of-the-art. In: Smaling E.M.A. (Ed.) *Nutrient balances as indicators of production and sustainability in sub-Saharan African agriculture*. Agric Eco Environ 71:19–36.
- Bationo A., Mokwunye U., Vlek P.L.G., Koala S., Shapiro B.I. and Yamoah C. 2003. Soil fertility management for sustainable land use in the West African Sudano-Sahelian zone. In: Gichuru M.P., Bationo A., Bekunda M.A., Goma P.C., Mafongoya P.L., Mugendi D.N., Murwira H.M., Nandwa S.M., Nyathi P. and M.J. Swift. *Soil fertility management in Africa: a regional perspective*. TSBF-CIAT. 2003
- Besmer Y.L., Koide R.T. and Twomlow S.J. 2003. Role of phosphorus and arbuscular mycorrhizal fungi on nodulation and shoot nitrogen content in groundnut and lablab bean. In: Waddington S.R. (Ed.). *Grain legumes and green manures for soil fertility in Southern Africa: Taking stock of progress*. Proceedings of a conference held 8–11 October 2002 at the leopard rock hotel, Vumba, Zimbabwe. Soil Fert Net and CIMMYT-Zimbabwe, Harare, Zimbabwe. pp 43–46
- Carsky R.J., Oyewole B. and Tian G. 2001. effect of phosphorus application in legume cover crop rotation on subsequent maize in the savannah zone of West Africa. *Nutrient cycling in agro-ecosystems*. 59: 151–159
- Cobo-Borrero J.G. 1998. *Abonos verdes como fuentes de nitrogeno en un agroecosistema tropical de ladera en Colombia*. M.Sc Thesis. CATIE, Costa Rica. P. 87
- Friesen D.K., Assenga R., Bogale T., Mmbaga T.E., Kikafunda J., Negassa W., Ojimi J. and Onyango R. 2003. Grain legumes and green manures in East African maize systems – An overview of ECAMAW Network research. In: Waddington S.R. (Ed.). *Grain legumes and green manures for soil fertility in Southern Africa: Taking stock of progress*. Proceedings of a conference held 8–11 October 2002 at the leopard rock hotel, Vumba, Zimbabwe. Soil Fert Net and CIMMYT-Zimbabwe, Harare, Zimbabwe. pp 113–118
- Gardner M.K., Parbery D.G. and Barker D.A. 1981. Proteoid root morphology and function in legumes alnus. *Plant soil* 60: 143–147
- Gikonyo E.W. and Smithson P.C. 2003. Effects of Farmyard Manure, Potassium and their Combinations on Maize Yields in the High and Medium rainfall Areas of Kenya. In: Bationo A. (Ed), *Managing nutrient cycles to sustain soil fertility in sub-Saharan Africa*. TSBF – CIAT, 2004
- Hoshikawa K. 1991. Significance of legume crops in improving the productivity and stability of cropping systems. In Johansen C., Lee K. K. and Sahrawat K.L (Eds). *Phosphorus nutrition of grain legumes in the semi-arid tropics*. ICRISAT, Patancheru, India.
- Kimetu J.M., Kihara J., Bationo A., Vanlauwe B. and Gachengo C. 2003. Optimum nitrogen and phosphorus management in Legume-cereal rotations in Western Kenya. Proceedings of the SSSEA, Eldoret Kenya, 1–6 December 2003
- Klajj M.C. and Ntare B.R. 1995. Rotation and tillage effects on yield of pearl millet (*Pennisetum glaucum*) and cowpea (*Vigna unguiculata*), and aspects of crop water balance and soil fertility in semi-arid tropical environment. *Journal of Agriculture Science, Cambridge* 124:39–44
- Lungu I.O. and Munyinda K. 2003. Agronomic effectiveness of phosphate rock products, mono-ammonium phosphate and lime on grain legumes in some Zambian soils. In: Waddington S.R. (Ed). *Grain legumes and green manures for soil fertility in Southern Africa: Taking stock of progress*. Proceedings of a conference held 8–11 October 2002 at the leopard rock hotel, Vumba, Zimbabwe. Soil Fert Net and CIMMYT-Zimbabwe, Harare, Zimbabwe. pp 189–196
- McIntire J. and Fussel L.K. 1986. On-farm experiments with millet in Niger. III. Yields and economic analyses. ISC (ICRISAT Sahelian Centre), Niamey, Niger
- Nandwa S.M. 2003. Perspectives on Soil Fertility in Africa. In: Gichuru M.P., Bationo A., Bekunda M.A., Goma P.C., Mafongoya P.L., Mugendi D.N., Murwira H.M., Nandwa S.M., Nyathi P.

- and Swift M.J. Soil fertility management in Africa: a regional perspective. TSBF-CIAT. 2003
- Sakala W.D., Cadisch G. and Giller K.E. 2002. Intercropping of maize and pigeon pea in Malawi: grain and biomass yields, N₂-fixation in pigeon pea, N-balances and residual effects on succeeding crops. *Plants and soil*. In press
- Sanchez P.A. 1976. *Properties and Management of Soils in the Tropics*. John Wiley and Sons, New York, USA
- Sanginga N., Okogun J.A., Vanlauwe B, Diels J., Carsky R. and Dashiell K. 2001. Nitrogen contribution of promiscuous soybeans in maize-based cropping systems. *Sustaining soil fertility in West Africa* – SSSA special publication. pp 157–177
- Spurgeon W.I. and Grissom P.H. 1965. Influence of cropping systems on soil properties and crop production. Mississippi Agriculture Experiment Station Bulletin No. 710
- Stoop W.A. and Staveren J.P.V. 1981. Effects of cowpea in cereal rotations on subsequent crop yields under semi-arid conditions in Upper Volta. In: Graham P.C. and Harris S.C. (Eds). *Biological Nitrogen Fixation Technology for Tropical Agriculture*, Cali, Colombia: Centro Internacional de Agricultura Tropical (CIAT)
- Sunnadurai S. 1973. Crop rotation to control nematodes in tomatoes. *Ghana Journal Agricultural Science* 6:137–139
- Vanlauwe B., Wendt J. and Diels J. 2001. Combined application of organic matter and fertilizer. In: Tian G., Ishida F. and Keatinge J.D.H. (Eds). *Sustaining soil fertility in West Africa*. SSSA Special Publication Number 58, Madison USA, pp 247–280
- Vanlauwe, B. Nwoke, O. C. Diels, J. Sanginga, N. Carsky, R.J. Deckers, J. Merckx, R. 2000. Utilization of rock phosphate by crops on a representative toposequence in the Northern Guinea savanna zone of Nigeria: response by *Mucuna pruriens*, *Lablab purpureus* and maize. *Soil Biology & Biochemistry*, Vol. 32, No. 14, pp 2063–2077

Evaluation of the Potential of Using Nitrogen Fixing Legumes in Smallholder Farms of Meru South District, Kenya

Jayne Mugwe¹, Daniel Mugendi², David Odee³ and John Otieno³

¹Research Scientist, Kenya Forestry Research Institute (KEFRI) formerly attached to National Agroforestry Research Project at the Kenya Agricultural Research Institute-Embu, P.O. Box 27, Embu. E-mail: Jaynemugwe@yahoo.com;

²Senior Lecturer, Kenyatta University. P.O. Box 43844, Nairobi. E-mail: dmugendi@yahoo.com; ³Microbiologist, Kenya Forestry Research Institute, Muguga. P.O. Box 20412, Nairobi. E-mail: dodee@africaonline.co.ke

Abstract

Soil fertility depletion in sub-Saharan Africa is a big constraint to increased food production to feed the ever-growing human population. Use of legumes to improve soil fertility is an option in the central highlands of Kenya and this study evaluated soil characteristics on farms and screened effectiveness of five rhizobia strains on four legumes. Soils sampled from 31 farms showed that the soils were generally acidic with more than 50% of the farms having pH in the range of extremely acidic and strongly acidic (pH < 5.0). Organic carbon was low (<2%) on most farms and total nitrogen was deficient with more than 80% having <0.2% N while P ranged from 1.3 to 15.8 ppm with more than 70% of the farms being critically deficient in P. Nodulation on *Mucuna pruriens* and *Crotalaria ochroleuca* was observed to be variable within farms with individual farms having fewer nodules per plant than on-farm researcher managed trial. Consequently trials to evaluate effectiveness of rhizobia strains were conducted under glass house conditions. Results showed that KWN35 and TAL 1145 were highly effective on *C. calothyrsus* and *L. trichandra* and not on *C. ochroleuca*. *Crotalaria ochroleuca* nodulated effectively only with CP354 and NGR457. The NGR 457 was highly effective on all the legume plants while NGR185 was only effective on *L. trichandra*. These studies showed that performance of legumes among the smallholder farms was likely to vary due to varying soil characteristics and that there could be potential for improving legume performance within the smallholder farms through inoculation

Key words: Legumes, Rhizobia strains, Soil characteristics

Introduction

Land, the natural resource base on which agriculture depends is becoming severely degraded through deforestation, soil fertility depletion, water scarcity, erosion of both soil and genetic resources (ICRAF, 2000). Soil fertility depletion is particularly becoming severe and nutrient budgets for sub-Saharan Africa show a net annual depletion of N, P and K as a result of long-term cropping with little or no external nutrients inputs (Stoorvogel and Smaling, 1990). This depletion of soil nutrients is particularly high in the densely populated humid and subhumid highlands of East Africa (Smaling

et al., 1997). This has greatly affected per capita food production which has been reported to be low and declining in many parts of Africa.

In central highlands of Kenya, where there is high population pressure (> 500 persons km²), nitrogen has been found to be one of the most limiting soil nutrient with an annual net depletion of 30 kg N ha⁻¹ (Ikombo, 1984) resulting in declining soil productivity. For instance, maize varieties with yield potentials of 7–12 Mg ha⁻¹ have been developed in onstation sites but the yields rarely exceed 1.5 Mg ha⁻¹ at the farm level (Wokabi, 1994). Use of fertilizer N to replenish soil N is the obvious source to counterbalance the

nutrient depletion in this region. However, this presents a challenge because of the high costs, poor efficiency of utilization of N from fertilizers (seldom exceeding 50%) and increasing awareness of the environmental costs of N lost from fertilizers (Bohlool et al., 1992). The use of N fixing legumes to address the current soil nutrient depletion and increase crop yields is a system that maximises use of natural methods of maintaining soil fertility and therefore has more capacity for stable and sustainable crop yields in the long term.

Several studies have shown legumes to be effective in improving soil fertility in many areas (Giller et al., 1997; Lathwell, 1990). However most of these studies have been conducted on-station under optimum conditions including rhizobium inoculation and P-fertilizer application. Adoption of legumes at the farm level is low as the legumes have not been adequately evaluated under conditions and in niches in which they are likely to be planted on-farm, where many soils could be severely depleted in nutrients that could affect performance of the legumes and consequently reduce the potential for nitrogen fixation. Nodulation of legumes is an indicator of the ability to fix N but nodulation is affected by site characteristics such as nutrient deficiencies and presence of native rhizobia capable of nodulating the legumes (Dommergues, 1995). There is a need to understand more the conditions under which these legumes are being introduced to on-farm conditions. This study therefore aimed at describing soil characteristics in on-farm trial sites, evaluate nodulation of the legumes, and screen response of the legumes to inoculation.

Materials and methods

Study site

The study was conducted in Chuka division, Meru South district, Kenya. According to Jaetzold and Schmidt (1983), the area is referred to as Upper Midlands 1 and 2 (UM1-UM3) or the main coffee/dairy land use system with an altitude of approximately 1500 m above sea level. Mean annual rainfall is about 1200 mm which falls in two seasons; the long rains lasting from March through June, forming the long rains season (LR) and short rains from October through December, forming the short rains season (SR). Annual mean temperature is about 20°C. The soils are mainly humic Nitisols (Jaetzold and Schmidt, 1983) that are deep, well weathered with moderate to high inherent

fertility. Land sizes in Chuka location are small ranging from 0.1–3 ha with an average of 1.2 ha. The main cash crops are coffee and tea while the main staple food crop is maize, which is cultivated from season to season mostly intercropped with beans. Farming is the major occupation of the population and farmers are faced with a problem of decreasing crop yields over time due to declining soil fertility.

Soil characterization

Soil samples were collected from 31 farms in Chuka experimental farms from 0–15 cm soil depth. The samples were analyzed for pH, exchangeable acidity, exchangeable magnesium, calcium, phosphorus and potassium, total organic carbon, available phosphorus and total nitrogen. All the analysis was carried out at ICRAF laboratories using ICRAF methods (ICRAF, 1995).

Nodulation assessment

Nodulation and N fixation characteristics were assessed approximately three months after planting. The area for assessment was selected at random, and 6 and 3 plants of crotalaria and mucuna respectively were uprooted. After the plants were uprooted, the soil was carefully washed off the roots with water and then examined for nodules. The parameters recorded included the number of nodules per plant, shape and size of nodules, internal colour and position and distribution on the roots.

Effectiveness of rhizobia strain

The legumes introduced on-farms (mucuna, crotalaria, calliandra and leucaena) were screened for ability to nodulate with different rhizobia strains. This work was carried out in a glasshouse at the Kenya Forestry Research Institute (KEFRI), Muguga, located 25 kilometers North West of Nairobi. The Rhizobia isolates used in this study were isolated from EU-calliandra project (KWN35), EU-IMPALA Project (CP 354), two strains from Canada (NGR 457 and NGR 185) and TAL 1145 from NIFTAL which was included as a positive control. The test plants were *Calliandra calothyrsus*, *Leucaena trichandra* and *Crotalaria ochroleuca*. The

experimental design was a randomized block design with four replications.

Well germinated seedlings were planted in pairs in Leonard jars containing N-free nutrient solution. The Leonard jar tops were filled with washed vermiculite as a rooting media and the bottom half acted as the nutrient reservoir. The plants were harvested at 12 weeks after planting. At harvest a stream of water from hose pipe was used to wash off the vermiculite and expose the nodules. Where nodulation occurred nodules were carefully handled not to cause any damage or breakage. The plants were analyzed for height, nodule number, nodule fresh weight, shoot dry weight, and nodule dry weight. After determining height, plants were cut to separate the shoot and the root. Shoot height was recorded in cm using a meter rule. Nodules were detached from the root, counted and fresh weight also recorded at the same time. The different parts of the plant were then put in brown paper bags and oven dried at 60°C for 3 days. The dry weights of the plants were then taken separately using an electronic weighing balance. Data on shoot height, nodule number, and shoot, root and nodule dry weight were statistically analyzed using Genstat programme (Genstat, 1995).

Results and discussions

Soil characterization

The pH of all soils ranged from 4.1 to 6.0 (Table 1) indicating that soils in smallholder farms of Chuka are acidic. Majority of the farms (67%) had soils in the category of extremely acidic or very strongly acidic and only 7% had their soils in the moderately acidic range (Figure 1). Under very acid soils the soil solution is occupied mostly by aluminium and hydrogen ions thus limiting availability of base forming cations (Ca^{2+} , Mg^{2+} , K^{+} and Na^{+}). The acidic nature of the soil

could thus affect availability of macro plant nutrients and especially phosphorus, which is readily available under medium pH range. Nitrogen fixation could also be affected as most rhizobia are not tolerant to acidity (Odee, 1996).

Total organic carbon and nitrogen were found to be low in most farms ranging from 1.45% to 2.26% and 0.05% to 0.25% respectively (Figure 2 & 3). Of the 31 farms sampled, 3 farms had very low soil N of less than 0.1% while more than 60% of the farms had low N of 0.11 to 0.2% (Table 2). Only 2 farms had organic carbon >2% (Figure 2) which according to rating by Landon (1984) is low. All the other farms had organic carbon in the very low range meaning that the soils lack the positive soil attributes provided by soil organic matter (SOM) such as, increased porosity and supply of N. This is critical because of all plant nutrients, N is required in the greatest quantity for plant growth and the capacity of the soil to supply N to plants is inextricably linked to the amount and nature of the soil organic matter which is the main source of available soil N in the soil (Giller et al., 1997).

The low SOM and N in these soils is mainly attributed to intensive cultivation as a result of population pressure leading to net losses of soil organic matter, reduced organic inputs, and faster rate of SOM turn over. There is usually net removal of soil nutrients through crop harvest as the crop residues are fed to livestock (Kihanda, 1996). The amounts of soil nutrients consequently applied via organic materials, mainly animal manure, are inadequate to counterbalance the nutrients removed in the previous cropping seasons. Soil organic matter high turnover is expected in these sites, which receive high rainfall and experience high temperatures. Faster SOM turnover rates have been reported in tropical soils caused by high temperature and available water that favour decomposition. Because of low SOM and N in Chuka soils supplementation with mineral fertilizers, manure or other organic residues is essential to ensure reasonable crop yields.

Phosphorus (P) was found to be low, ranging from 1.3 to 15.8 ppm with more than 70% of the farms being critically deficient in P (Table 3). Only 2 farms (6%) of the farms had P in the adequate range of 13–22 ppm. The low P could drastically affect crop production as P is a major plant nutrient needed for numerous metabolic processes. It is very important for photosynthetic processes, crop maturation and root development. Low P levels have earlier been reported in the region (Micheni et al., 2000) and seem to be widespread on the farms.

Table 1. pH rating of soils sampled from farms in Chuka, Kenya

Category	Ratings of pH	No. of farms	% farms
Extremely acidic	4.0–4.4	6	19
Very strongly acidic	4.5–5.0	15	48
Strongly acidic	5.1–5.5	8	25
Moderately acidic	5.6–6.0	2	7

Rating adapted from Landon (1984).

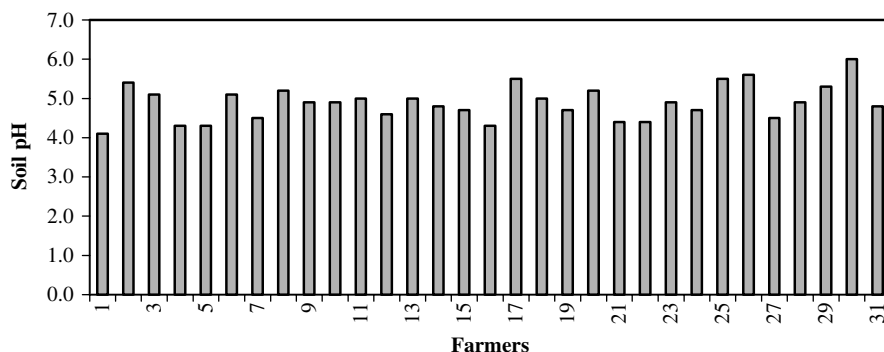

Figure 1. Soil pH of soils sampled from individual farms at Chuka.

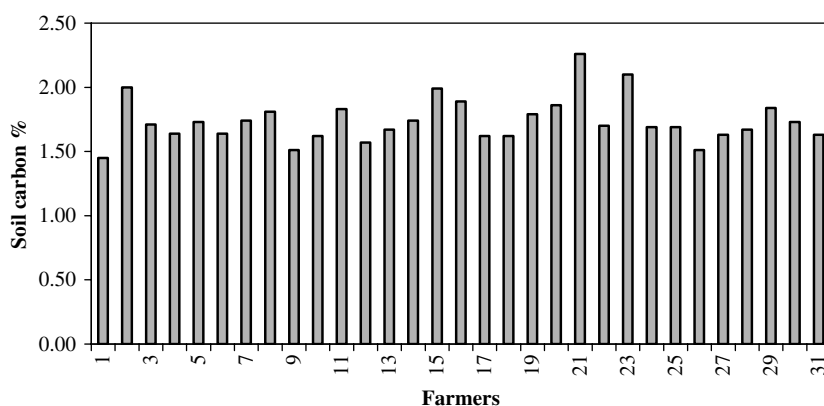

Figure 2. Organic carbon levels of soils sampled from farms in Chuka.

Table 2. Total nitrogen ratings of soils sampled from farms in Chuka, Kenya

Category	Nitrogen (%)	No. of farms	% farms
Very high	>1.0	n.a.	
High	0.5–1.0	n.a.	
Medium	0.2–0.5	6	19
Low	0.1–0.2	22	71
Very low	<0.1	3	10

Source: Rating adapted from Landon (1991).

Low soil P levels are mainly attributed to inherent low soil P levels, high fixing nature of the predominant soils (Nitisols) and depletion of soil P due to cropping without adequate P inputs. Unlike nitrogen, plant P requirements are not supplied through biochemical fixation and most of it comes from other sources. In these smallholder farms some important sources could be mineral fertilizers, animal manures and plant residues.

Nodulation in the field

Nodulation in the researcher managed on-farm trial located in the school was better than in farmer-managed trials on individual farmers' fields. In the school trial, the number of nodules per plant in crotalaria ranged from 13 to 67 while the mean number in individual farms ranged from 12 to 35 (Tables 4 & 5). For mucuna,

Table 3. Extractable phosphorus of soils sampled from farms in Chuka

Extractable P (ppm)	Rating	Number of farms	Percent farmers
<3	Acutely deficient	2	6
3.1–6.5	Deficient	16	52
6.6–13	Marginal	11	36
13–22	Adequate	2	6
>22	Rich	none	n.a.

Rating adopted from Landon (1984).

Table 4. Number of nodules in herbaceous legumes during in June 2003 at on-farm researcher managed trial in a school, Chuka

Treatment	Number of nodules	
	Mean	Standard deviation
Crotalaria alone (Mean of 3 plots)	Mean	28 (10)
	Maximum	38
	Minimum	13
Crotalaria + 30 Kg N ha ⁻¹ (Mean of 3 plots)	Mean	38 (17)
	Maximum	67
	Minimum	16
Mucuna alone (Mean of 3 plots)	Mean	10 (7)
	Maximum	22
	Minimum	2
Mucuna + 30 Kg N ha ⁻¹ (Mean of 3 plots)	Mean	8 (7)
	Maximum	22
	Minimum	2

() Standard deviation.

Table 5. Nodulation of *Crotalaria ochroleuca* on individual farms during June 2003

Farmers name	Number of nodules		
	Mean	Minimum	Maximum
Ephantus Mwiti	20 (7)	10	30
Jamleck Njogu	31 (10)	21	40
Kaari Mbuba	35 (11)	18	48
Kanga Muga	22 (10)	11	34
Lilian Kagendo	12 (8)	4	24
Mbae M'rachi	13 (10)	4	28
Micheni Kaaria	17 (11)	8	36
Njeri Gitare	21 (6)	15	30
Washington Gitonga	17 (3)	13	21
Zablon Kaaria	29 (13)	12	47
Mean	22	12	34

() Standard deviation.

the school trial had a mean of 10 nodules per plant (mucuna alone) while the mean number of nodules plant⁻¹ from farmers' fields was 6. These differences could be attributed to differences in soil nutrient availability. In the school trial, a blanket P fertilization had been done and this could have boosted development of nodules more than in the on-farm trials where farmers applied little or no P fertilizer.

The predominant size of mucuna nodules was close to a maize seed. It has an irregular shape. The nodules were black in colour, the periphery of the nodules was brownish while the middle was green and according to CIAT (1988) they were effective. In most plants, about 75% of the nodules were located on the tap root i.e. main root. This agrees with report by Gitare et al.

(1997) who reported that the nodule density of mucuna in Gachoka and Karurina sites at Embu, Kenya range from 25–50 with majority being located along the main laterals.

Most of the nodules in crotalaria were located at the main lateral roots. The nodules were small (millet size) and white in color at the surface. When dissected, the colors observed were light green in the middle and brown/pink along the periphery with pink being predominant indicating that they were generally effective.

Generally when compared with studies carried out by the Legume Network Project in Kenya, nodulation in the Chuka site was low especially under individual farms though crotalaria was well established in some farms. Though this project recommended planting of these legumes without inoculation because they felt that the indigenous rhizobium was adequate, it is suspected that lack of inoculation might contribute to low nodulation.

Effectiveness of *Rhizobia* strains

There was response to inoculation in calliandra. Plant height, shoot and root dry weight, and nodulation were significantly different ($p = 0.05$) among the rhizobia strains with KWN 35 recording the highest height growth and shoot dry weight (Table 7). However the number of nodules per plant was highest in TAL 1145, having 121 nodules, followed by KWN 35 with

Table 6. Nodulation of *Mucuna pruriens* on farms during June 2003

Farmer's name	Number of nodules		
	Mean	Minimum	Maximum
Ephantus Mwiti	3 (0)	3	3
Jamleck Njogu	8 (5)	3	13
Kaari Mbuba	10 (5)	4	14
Kanga Muga	10 (1)	10	10
Lilian Kagendo	3 (1)	2	3
Mbae M'rachi	2 (1)	2	3
Micheni Kaaria	6 (1)	5	7
Njeri Gitare	8 (6)	2	15
Washington Gitonga	2 (1)	1	3
Zablon Kaaria	2 (1)	2	3
Philis Kirimo	8 (11)	1	22
Mean	6	3	9

() standard deviation.

Table 7. Effect of rhizobium strains on plant height, shoot dry weight, root dry weight, nodule numbers per plant, nodule dry weight of *Calliandra calothyrsus* after 12 weeks of growth in Leonard jars

Strain	Plant height (cm)	Shoot dry weight plant ⁻¹ (g)	Root dry weight plant ⁻¹ (g)	No. of nodule plant ⁻¹	Nodule dry weight plant ⁻¹ (g)
CP354	13.5	0.51	0.56	28	0.26
KWN 35	22.4	1.10	0.75	76	0.36
NGR 185	15.2	0.64	0.02	58	0.37
NGR 457	16.4	0.74	0.46	54	0.48
TAL 1145	16.9	1.18	0.66	121	0.52
Control +N	6.8	0.31	0.34	0	0
Control -N	10.6	0.09	0.02	0	0
SED	2.2	0.14	0.17	13	0.08

Each value is the mean of 4 replicates.

76 nodules. The Canadian strains showed medium performance with 58 and 54 nodules per plant for NGR 185 and NGR 457, respectively. The good performance of KWN 35 was expected as it has been selected as the most effective strain for nodulating calliandra (Pottinger and Lesuer, 2003). It is interesting to note the nodule weight of NGR 185, NGR 457 and TAL 1145 out performed KWN 35 and should therefore be considered for future screening work with calliandra.

Leucaena results showed that three strains KWN 35, NGR 185 and NGR 457 recorded the highest height growth though shoot dry weight was low for NGR 185 (Table 8). The highest number of nodules was recorded in CP 354 (47 nodules) and TAL 1145 (48 nodules) though TAL 1145 had significantly higher nodule weight than all other strains. The control treatments gave, as expected, the lowest plant height, shoot and root dry weight and did not develop any nodules. The Canadian strains recorded medium performance.

Highest number of nodules in *Crotalaria ochroleuca* was recorded in with CP 354 and NGR 451 with 55 and 59 nodules per plant, respectively (Table 9). These two strains also recorded the highest plant height, shoot and root dry weight, and nodule weight. The two strains therefore have potential for use in inoculating crotalaria.

This initial screening of rhizobia strains showed that their effectiveness to nodulate the different species varied. This agrees with results of other authors (Turk and Keyser, 1992) who found differences in nodulation of tree legumes. They reported that calliandra and leucaena were nodulating effectively with rhizobia isolated from 3 genera while Sesbania effectively nodulated only with rhizobia isolates of members of that genus. Such information is important in selecting strains that would be more effective in different species. There is need to continue this work and assess how the species will respond to inoculation with the same rhizobia strains in soils collected from the trial sites.

Table 8. Effect of rhizobium strains on plant height, shoot dry weight, root dry weight, nodule numbers per plant, nodule dry weight of *Leucaena trichandra* after 12 weeks of growth in Leonard jars

Strain	Plant height (cm)	Shoot dry weight plant ⁻¹ (g)	Root dry weight plant ⁻¹ (g)	No. of nodule plant ⁻¹	Nodule dry weight plant ⁻¹ (g)
CP354	20.3	0.57	0.31	47	0.034
KWN 35	26.7	1.79	0.8	39	0.039
NGR 185	26.7	0.25	0.13	20	0.016
NGR 457	17.4	0.76	0.63	28	0.179
TAL 1145	21.6	1.88	1.45	48	0.033
Control +N	13.5	0.55	0.42	0	n.a.
Control -N	11.8	0.17	0.01	0	n.a.
SED	1.4	0.14	0.13	8	0.032

Each value is the mean of 4 replicates.

Table 9. Effect of rhizobium strains on plant height, shoot dry weight, root dry weight, nodule numbers per plant, nodule dry weight of *Crotalaria ochroleuca* after 12 weeks of growth in Leonard jars

Strain	Plant height (cm)	Shoot dry weight plant ⁻¹ (g)	Root dry weight plant ⁻¹ (g)	No. of nodule plant ⁻¹	Nodule dry weight plant ⁻¹ (g)
CP354	35.8	3.38	1.6	56	0.82
KWN 35	18.7	0.88	0.60	43	0.02
NGR 185	9.7	0.52	0.35	29	0.19
NGR 457	35.4	3.14	1.91	59	0.57
TAL 1145	10.2	0.44	0.38	0	n.a.
Control +N	22.8	1.52	0.79	0	n.a.
Control -N	9.7	0.26	0.08	0	n.a.
SED	1.3	0.14	0.06	14	0.07

Each value is the mean of 4 replicates.

Conclusions and Recommendations

This study revealed that the soils in Chuka farms are generally acidic, were low in total nitrogen and organic carbon. The soils were also deficient in available phosphorus. These soil conditions could adversely affect performance of legumes. Nodulation of herbaceous legumes on farms was found to be variable with some of the farms having very low numbers of nodules per plant especially for mucuna. Poor nodulation could be due to soil acidity, low soil P levels and possibly lack of adequate indigenous rhizobia. Screening of rhizobia strains under glasshouse conditions showed variation in the effectiveness of the rhizobia on the different legumes. Indications are that *crotalaria* could benefit from inoculation with rhizobia from Canada (NGR 457). Further screening of the legumes using soils collected from the trial sites is recommended. Evaluation on whether the tested legumes would respond to P application and inoculation in the field is also recommended.

Acknowledgement

The authors wish to express their gratitude to TSBF/AfNet, The Bentley Fellowship and Swedish International Development Agency (Sida) through the National Agroforestry Research Project for providing funds to carry out this work. We are also grateful to the staff working at the Kenya Forestry Research Institute (KEFRI), Biotechnology laboratory for managing the glasshouse experiments. The farmers in Chuka who participated in this study are acknowledged.

References

- Bohlool B.B., Ladha, J.K., Garrity D.P. and George T. 1992. Biological nitrogen fixation for sustainable agriculture: a perspective. *Plant and Soil* 141: 1–11.
- CIAT 1988. Legume – Rhizobium Symbiosis. Methods Manual for Evaluation, Selection and agronomic Management. Centro Internacional de Agricultura Tropical Apartado. 6713, Cali, Colombia.
- Dommergues Y. R. 1995. Nitrogen fixation by trees in relation to soil nitrogen economy. *Fertilizer Research* 42: 215–223.
- Genstat 1995. Genstat 5 Release 3.2 for Windows 95. Lawes Agricultural Trust, Rothamstead Experimental Station, UK.
- Giller K.E., Cadish G., Ehaliotis E., Adams E., Sakala W.D. and Mafongoya P.L. 1997. Building-up soil nitrogen capital in sub-Saharan Africa. In: Sanchez P.A. (ed.) Replenishing soil Fertility in Africa., Special publication of the American Society of Agronomy, Madison, WI, USA.
- Gitare J.N. Dyke E.A. and Maina P. 1997. Legume screening for soil fertility improvement, food and fodder utilization in medium altitude areas of Mount Kenya region. In: Mureithi J.N. Mwendia C.W., Muyekho F.N., Anyango M.A. and Maobe S.N. Participatory Technology Development for Soil Management by Smallholders in Kenya. A compilation of selected papers presented at the Soil Management and Legume Research Network Project Conference Kanamai, Kenya. National Agricultural Laboratories, Nairobi, Kenya.
- ICRAF 1995. Laboratory methods for soil and plant analysis. Version 1.1, International Centre for Research in Agroforestry (ICRAF), Nairobi, Kenya.
- ICRAF 2000. Paths to Prosperity through Agroforestry. International Centre for Research in Agroforestry (ICRAF) Corporate Strategy, September 2000.
- Ikombi B.M. 1984. Effects of farmyard manure and fertilizers on maize in semiarid areas of Eastern Kenya. *East Africa Agriculture and Forestry Journal* 44: 266–274.
- Jaetzold R. and Schmidt H. 1983. Farm management handbook of Kenya. Vol II/C, East Kenya. Natural condition and farm management information, Ministry of agriculture, Nairobi.

- Kihanda F.M. 1996. The role of farmyard manure in improving maize production in the sub-humid highlands of central Kenya. Ph. D dissertation. The University of Reading, UK.
- Landon J.R. 1984. Booker soil manual. A handbook for soil survey and agricultural land evaluation in the tropics. USA, Longman Inc. New York.
- Landon J.R. 1991. Booker Tropical Soil Manual: A handbook of soil survey and agricultural and evaluation in the tropics and sub-tropics. Booker Tate Essex: Longman Scientific and Technical Publishers Harlow, UK.
- Lathwell D.J. 1990. Legume green manures – principles for management based on recent research. Tropical soils bulletin No. 90–01. North Carolina State University, USA.
- Micheni A.N., Mugendi D.N., Mugwe J.N., Kung'u J. and Gitari. J. 2000. Low-cost soil fertility amendment strategies for improved crop production in Maize cropping systems in central highlands of Kenya. In: Mureithi J.C., Macharia P., Gichuru M., Mburu M., Mugendi D. and Gachene C.N.N. (eds.) Sustainable use for land resources to alleviate poverty in the new millennium. Proceedings of the 18th Soil Science Society of East Africa Conference (SSSEA) held in Mombasa (4–8 December, 2000). National Agricultural Research Laboratories, KARI, Nairobi, Kenya. pgs 111–117.
- Pottinger A.J. and Leuseur D. 2003. Evaluation and use of biodiversity of the microsymbionts of *Calliandra calothyrsus* to optimize fodder production within small-scale farming systems in the humid zones. The European commission, EU Project No. Ic18-CT97-0194.
- Smaling E.M.A. Nandwa S.M. and Janssen B.H. 1997. Soil fertility is at stake. In replenishing soil fertility in Africa. Special publication No. 51 Madison, Wisconsin: American Society of Agronomy and Soil Science society of America.
- Stoorvogel J.J. and Smaling E.M.A. 1990. Assessment of soil nutrient depletion in sub-Saharan Africa: 1983–2002. Vol III. Literature review and description of land use systems. Report 28, The Winand Staring Centre, Wageningen, The Netherlands.
- Turk D. and Keyser H.H. 1992. Rhizobia that nodulate tree legumes: Specificity of the host for nodulation and effectiveness. *Canadian Journal of microbiology* 38:451–469.
- Wokabi S.M. 1994. Quantified land evaluation for maize yield gap analysis at three site on the Eastern slope of Mt. Kenya. International Institute for Aerospace Survey and Earth Sciences (ITC). The Netherlands.

Improved cassava varieties increase the risk of soil nutrient mining: an ex-ante analysis for western Kenya and Uganda

Fermont A.M.^a, Obiero H.M.^b, van Asten P.J.A.^a, Baguma Y.^c, Okwuosa E.^b

^aIITA-UGANDA, P.O. BOX 7878, Kampala, Uganda, a.fermont@cgiar.org Tel/fax: +256-414-285-060/079;

^bKARI-Kakamega, P.O. BOX 169, Kakamega, Kenya; ^cNARO/NAARI, P.O. BOX 7084, Kampala, Uganda

Abstract

Cassava production in Uganda and western Kenya has been hit hard by the cassava mosaic disease (CMD) epidemic. In response, CMD resistant cassava varieties are currently released on a wide scale. The new varieties yield up to 3 times more than the local varieties. These high yield levels will put major pressure on soil nutrient stocks. Using a local variety, an average farmer will harvest about 10 t ha⁻¹ fresh roots, thereby removing 26 kg N, 3 kg P and 19 kg K per hectare. Using a good CMD-resistant variety, the same farmer can harvest a 30 t ha⁻¹, thereby removing 83 kg N, 10 kg P and 47 kg K per hectare. If stems are used for planting material and/or firewood, then removal increases to 216 kg of N, 22 kg of P and 102 kg of K per ha for CMD-resistant varieties.

Soils in western Kenya and Uganda are predominantly Ferrasols, Acrisols and Nitisols; old weathered soils with small nutrient stocks. Without the use of fertilizers, the rapid depletion of soil nutrient stocks seems unavoidable with the new varieties. This will eventually result in yield decline of cassava and rotational crops. The question arises if traditional cropping systems are suitable for cultivating crops with high nutrient demand. However, production levels of banana, the other important food crop in Uganda, have been sustained for over half a century in several parts of the country, despite K requirements (142 kg ha⁻¹yr⁻¹) of good yielding bananas (25 t ha⁻¹yr⁻¹) being similar to that of good-yielding cassava varieties. But, in contrast to cassava fields, traditional banana fields maintain their soil fertility through large amounts of organic inputs, on the expense of annual cropped fields and grassland. Due to the position of cassava in the farming system, it is unlikely that soil management strategies in banana can be successfully adopted by cassava farmers. However, rotating the improved cassava varieties with fertilized cash crops and introducing promiscuous leguminous inter- and relay crops in cassava fields are potential management options to improve the sustainability of the system. Nonetheless, the development of K deficits will remain a serious concern. The high yield levels of the new cassava varieties have already triggered its promotion as a cash crop. Provided that there is a good (industrial) market outlet, farmers can be motivated to use targeted organic & inorganic fertilizer to prevent soil fertility depletion

Key words: Cassava, soil fertility, nutrient removal, East Africa

Introduction

The cassava mosaic disease (CMD) epidemic that started in Uganda in the early nineties has presently reached most of eastern and central Africa with devastating effects on cassava production (Otim-Nape et al., 2000). IITA and its national partners are successfully

developing and releasing CMD resistant cassava varieties to counteract its impact. The latest introductions have a high yield potential characterized by multiple resistance to the major biotic stresses, drought tolerance, earliness and higher dry matter content. Yield levels up to 50 t/ha in advanced yield trials have been obtained in Uganda and western Kenya (Obiero, 2004;

NAARI, 2000). These yield levels have raised concerns about the impact of the new varieties on soil fertility depletion.

Soil fertility depletion has been described as one of the most important constraint to food security in sub-Saharan Africa. Nutrients are commonly not replaced to the degree that they are removed in crop harvesting and other losses, resulting in highly negative nutrient balances (Hilhorst and Muchena, 2000; Stoorvogel and Smaling, 1990). Soils in western Kenya and Uganda are predominantly Ferrasols, Acrisols and Nitisols; old weathered soils that contain predominantly kaolinite and are virtually free of weathering minerals (Braun et al., 1997; Andriessse and van der Pouw, 1985; Jaetzold and Schmidt, 1983). Their fertility (available N and P) is closely related to soil organic matter content and, therefore, to the presence or absence of fallow periods (Foster, 1981; Jones, 1972).

Cassava has numerous traits that offer comparative advantages in marginal environments where farmers often lack the resources to improve their lands through purchased inputs. Its tolerance to poor, acidic soils, high levels of exchangeable aluminum, low concentrations of P in the soil solution and drought periods provides it with the ability to grow and produce reasonable yields in places where other crops do not produce well (Howeler, 2002; Fresco, 1986; Cock and Howeler, 1978). As a result, cassava is often produced on areas with soil problems, while the better soils are devoted to 'more profitable' crops (Fresco, 1993).

In this article we will carry out an ex-ante analysis to evaluate the potential impact of improved varieties on soil fertility depletion in Uganda and western Kenya by means of 1) estimating nutrient removal in four scenarios and analyzing soil fertility management in cassava cropping systems and 2) comparing these results to soil nutrient management of traditional banana cropping systems that have nutrient requirements comparable to good yielding CMD-resistant cassava varieties.

The importance of cassava in Uganda and Kenya

Although cassava (*Manihot esculenta*) was already introduced in Africa in the 16th century, it took until the early 19th century before the crop was grown on a large scale in eastern Africa (Hillocks, 2002). Currently it is one of the main staple foods in the region. It's adaptability to relatively marginal soils and erratic rainfall conditions, its high productivity per unit of land and labour, the certainty of obtaining some yield even

under the most adverse conditions, and the possibility of maintaining continuity of supply throughout the year make this crop a basic component of farming systems in eastern Africa (Fresco, 1986; Nweke et al., 1994).

In terms of total production, cassava is the second most important staple food in Uganda, while it is the fifth most important staple food in Kenya. According to the FAO, total annual production levels and area under cassava in 2002 range from 610,000 tons and 80,000 ha in Kenya to 6,300,000 tons and 390,000 ha for Uganda (FAO, 2004). Cassava is grown throughout Uganda and Kenya, but the main production zones are the northern and eastern parts of Uganda and the western provinces and the coastal zone of Kenya.

Actual and potential yield levels

According to the FAO (2004) actual fresh yield levels for cassava in Uganda are between 12 and 13.5 t/ha. Current farmer yield levels are on average 4 t/ha higher than before the start of the CMD epidemic and 7 t/ha higher than during the main years of the CMD epidemic (1994–1997). This is likely to be due to: (i) the introduction of improved, CMD resistant varieties, whose proportion increased from 0% in 1996 to 35% in 2003, (ii) possibly to the adoption of local varieties with some degree of resistance or tolerance to CMD, and (iii) to a recovery of yield levels of local varieties once the height of the CMD epidemic has past (Legg et al., 2004). These data correspond well to the average yield level of 10.6 t ha⁻¹ that the COSCA study for Uganda determined in 1990 (Nweke et al., 1999). FAO data for Kenya do not really show the impact of the CMD epidemic on production as fresh yield levels remain constant between 8.5 and 9.5 t ha⁻¹ for the past decade (FAO, 2004). Annual reports for the main cassava districts of western Kenya, however, show that yield levels dropped from 7–10 t ha⁻¹ to 4–8 t ha⁻¹ during the height of the cassava epidemic in the late nineties (Anonymous, 1998; 1999).

Potential cassava yields of improved varieties are much higher than the reported actual yields in Kenya and Uganda (Table 1 and 2). Average fresh yield levels obtained in on-station and on-farm trials depend on agro-ecology and climate and ranged between 9 and 41 t ha⁻¹ and 12 and 25 t ha⁻¹ for Uganda and Kenya respectively. Maximum yield in these trials ranged between 18 and 59 t ha⁻¹ in both countries. Tables 3 and 4 show that average yield levels of local varieties are 0 to 20 t ha⁻¹ lower than those of CMD-resistant

Table 1. Fresh cassava yield¹ (t ha⁻¹) of improved varieties (n = number of varieties evaluated) in Uganda

Trial	n	Minimum	Maximum	Mean
On-farm, 6 districts 1993–1995 ²	8	7.2 (Masindi '94)	23.1 (Soroti '94)	15.2
Advanced yield trial, 1996/7 ³				
– Namulonge	19	13.1 (94/NA00044)	35.2 (94/NA-00172)	18.8
– Serere	21	13.8 (Nase 2)	51.2 (94/SE-00061)	31.2
Advanced yield, 5 loc., 1997/8 ⁴	21	5.9 (95/SE-0348)	30.1 (95/SE-00044)	18.9
Uniform yield, 4 loc., 1997/8 ⁴	19	6.8 (TMS 83350)	29.1 (94/SE-00088)	18.6
Multi-locational trials, 1998/99 ⁵	16	9.0 (MH95/0080)	30.7 (Nase 12)	19.5
Uniform yield trials, 1999/2000 ⁶	10	9.7 (MM96/0549)	26.8 (Nase 2)	19.4
– Namulonge	9	4.2 (95/SE-00087)	19.0 (I92/2327)	9.4
– Masafu	9	9.3 (MM96/1425)	19.5 (I92/2327)	12.7
– Kumi	9	16.7 (95/SE-00087)	51.3 (I92/2327)	33.0
– Serere				
On-farm, 6 districts, 2001/2002 ⁷		28.2 (I91/2327)	59.0 (TME 204)	40.8
– Soroti	5	22.5 (MM92/00057)	50.0 (MM92/00067)	34.6
– Katakwi	5	23.9 (TME 14)	32.4 (MM92/00057)	26.4
– Kumi	6	7.9 (I92/2327)	24.2 (Nase 3)	14.5
– Pallisa	5	19.2 (MM92/00067)	34.7 (I92/2327)	25.8
– Apac	4	15.6 (MM92/00057)	21.2 (MM92/00067)	18.0
– Lira	4			
Yield assessment, Serere, 2002/3 ⁸	5	29.3 (TME 14)	44.0 (I92-0427)	34.2

1. All data refer to sole cropped cassava planted at 10,000 plants per ha.

2. Bua et al., 1997.

3. NAARI, 1997.

4. NAARI, 1998.

5. Ssemakula, 2000.

6. NAARI, 2000.

7. NARO, 2003.

8. Unpublished data IITA.

Table 2. Fresh cassava yield¹ (t ha⁻¹) of improved varieties (n = number of varieties evaluated) in western Kenya

Trial	N	Minimum	Maximum	Mean
Advanced yield, 3 loc., 2000/01 ¹	21	15.3 (MM96/4510)	43.5 (MM97/2283)	25.1
On-farm, 7 loc., 2000/01 ¹	16	18.4 (SS4)	51.1 (MH95/0183)	27.9
Advanced yield, Oyani, 2001/02 ¹	31	2.9 (I92/0323)	32.5 (MM96/7023)	11.8
Advanced yield, 2 loc., 2002/03 ¹	17	15.5 (MM96/2480)	24.0 (MM96/3665)	18.5
Agronomy trials, Alupe, 2003/4 ²	3	13.5 (Nase 3)	18.2 (MM96/4884)	15.8

1. Obiero, 2004.

2. Unpublished data A. Fermont, H. Obiero & E. Okwuosa.

varieties. Maximum yield levels of the improved varieties can be up to 35 t ha⁻¹ more than the maximum yield levels obtained with local varieties.

Nutrient removal in cassava cropping systems

The amount of nutrients removed with cassava harvest is highly dependent on growth rate and yield, which in turn depend on climate, soil fertility conditions and variety. However, Howeler (2002), who analyzed data

from 15 cassava trials reported in literature, found that there was a good relation between dry matter yields and removal of nitrogen (N), phosphorus (P) and potassium (K). Working with his data, removal of N, P and K (kg ha⁻¹) were expressed as a function of dry matter root yield and as a function of total dry matter yield (roots, stems and leaves). Figure 1 present the functions for nutrient removal by roots, while Table 5 gives equations and R² for nutrient removal by both root and total dry matter yield. Using these data, an estimation of nutrient removal in four different fresh root yields

Table 3. Mean fresh cassava yield ($t\ ha^{-1}$) of local varieties in researcher trials in Uganda

Trial	Name of local variety	Mean yield
On-farm trials, 6 districts, 1993–1995 ¹	Various	6.7
Advanced yield, Namulonge, 1999/2000 ²	Ogwook	9.9
On-farm trials, 5 districts, 2001/2002 ³	various	12.2
Agronomy (2), Namulonge, 2003/4 ⁴	- Njule	15.1
	- Bao	8.4
	- Nyaraboke	7.6

1. Bua et al., 1997.

2. NAARI, 2000.

3. NARO, 2003.

4. Unpublished data A. Fermont & Y. Baguma.

Table 4. Mean fresh cassava yield (t/ha) of local varieties in researcher trials in western Kenya

Trial	Name of local variety	Mean yield
On-farm trials, 7 locations, 2000/01 ¹	Serere & Adhiambo lera	10.2
Agronomy trials (2), Alupe, 2003/4 ²	- Matuja	13.1
	- Mwitamajera	6.7
	- Gachaga	7.0

1. Obiero, 2004.

2. Unpublished data A. Fermont, H. Obiero & E. Okwuosa.

scenarios is made. The four scenarios are: (1) local variety ($10t/ha$), (2) improved variety – moderate yield level ($20\ t\ ha^{-1}$), (3) improved variety – good yield level ($30\ t/ha$) and (4) improved variety – very good yield level ($40\ t\ ha^{-1}$). Dry matter content and harvest index of local and improved varieties is taken as 35% and 37%, and 39% and 60% respectively (Fermont, Baguma, Obiero and Okwuosa, unpublished). Table 6 gives a summary of the amount (kg) of N, P and K removed per hectare when (a) only roots removed, and when (b) all roots, stems and leaves removed. Nutrient removal ranges from 26 to 111 kg N ha^{-1} , 3 to 13 kg P ha^{-1} and 19 to 74 kg K ha^{-1} if only the roots are removed. When all biomass is removed from the field, nutrient removal increases to 120 to 274 kg N/ha, 11 to 29 kg P ha^{-1} and 52 to 156 kg K ha^{-1} . Most farmers in Uganda and western Kenya use available stem material for either planting material or fire wood (Wortmann & Kaizzi, 1998). Only part of the leaves remains in the field. Actual nutrient removal in cassava fields will therefore be closer to scenario ‘b’. Nutrient removal in scenario ‘1b’ (local variety; all biomass removed) is comparable to the nutrient removal of an average double maize crop of $1.8\ t\ ha^{-1}$ per harvest with

all stover removed in western Kenya (van den Bosch et al., 1998).

Like elsewhere in Africa, cassava in Uganda and western Kenya is commonly grown in intercropping systems. In Uganda, only 5% of all cassava is grown as a sole crop. In approximately three quarters of the intercropping systems, cassava is the major intercrop, while in 20% it is the minor crop. Cassava-cereal systems (maize, sorghum, millet) are by far the most common in Uganda and western Kenya, but cassava-legume systems (phaseolus beans, peas, groundnut) are also widespread (Nweke et al., 1999). Yield levels of cassava in an intercropping system depend, amongst others, on planting density, type of intercrop, cassava variety and relative planting time (Leihner, 1983). Considering that the average yield level of cassava fields in the COSCA study for Uganda was $10.6\ t\ ha^{-1}$ and 95% of those fields was intercropped, nutrient removal by cassava in intercropped systems will be very similar to scenario 1 (i.e. local variety, $10\ t\ ha^{-1}$). The inclusion of an intercrop in the system will increase nutrient removal through harvest of the intercrop. Cassava-legume systems may benefit from N supplied by the legume, but will still have a higher removal of K and P than sole cropped cassava. Phaseolus beans are the most common legume intercrop, but, unfortunately, their effect on the N balance is small or even negative.

Soil fertility management in cassava cropping systems

Table 7 shows the soil fertility practices used in cassava fields on a village level in Uganda. Soil fertility management in western Kenya is very similar to Uganda. Intercropping with legumes is used in all villages, while only 15 and 5% of the villages use manure and chemical

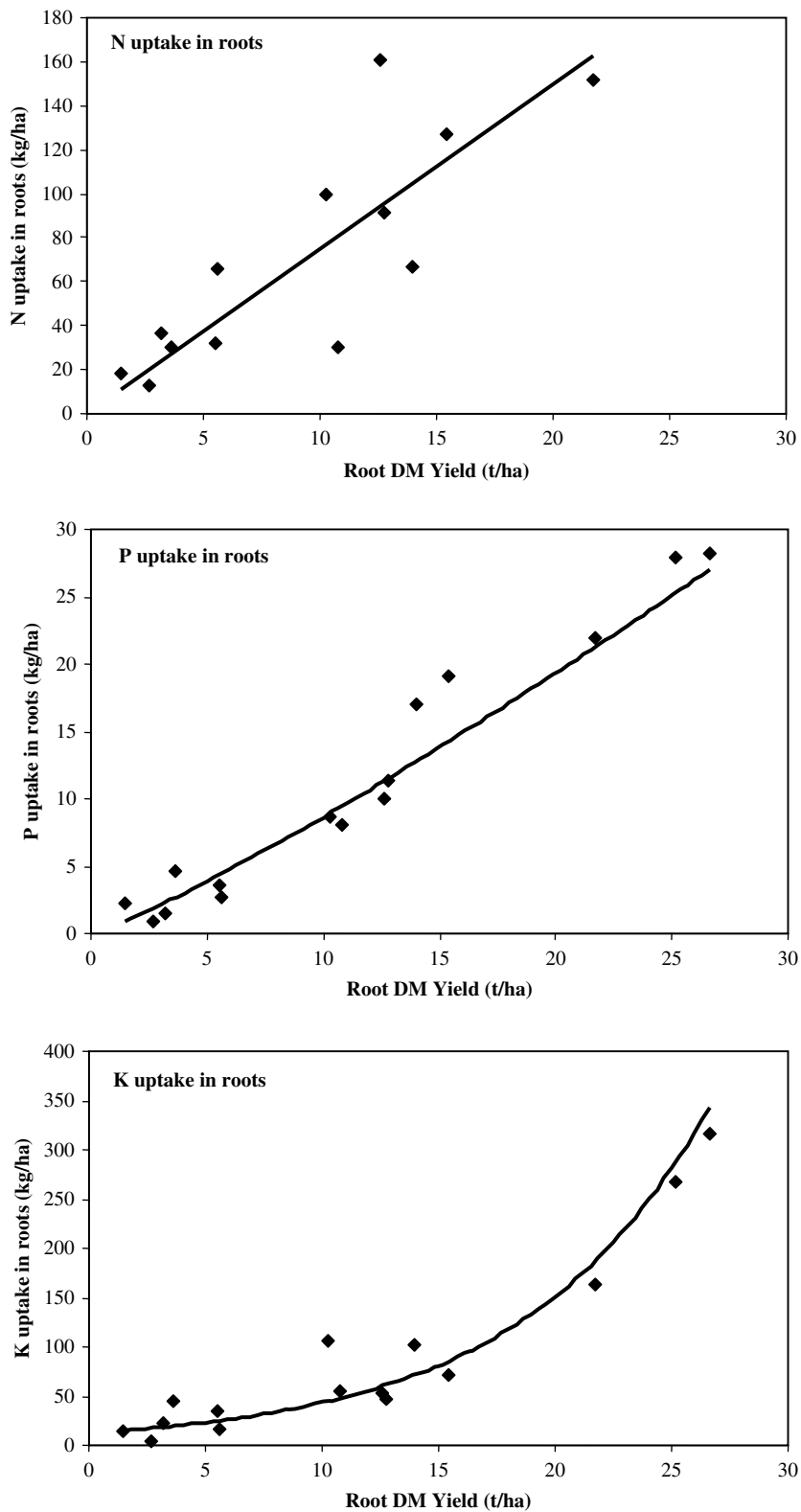

Figure 1. Relationship between N, P and K uptake in roots (kg ha^{-1}) and root dry matter yield (t ha^{-1}).

Table 5. Equations and R^2 's for nutrient uptake (kg/ha) for root dry matter and total yield

Roots		
N	$y = 7.49 x$	$R^2 = 0.67$
P	$y = 0.59 x^{1.16}$	$R^2 = 0.87$
K	$y = 12.52 e^{0.12x}$	$R^2 = 0.77$
Total yield		
N	$y = 19.77 x^{0.82}$	$R^2 = 0.71$
P	$y = 1.17 x$	$R^2 = 0.86$
K	$y = 27.79 e^{0.07x}$	$R^2 = 0.76$

fertilizer respectively. As discussed before N contribution of legumes is highly variable and may even be negative, especially if phaseolus beans are used as an intercrop. Residue incorporation will be mainly fresh leaves and litter fall collected on the soil surface during the growing season as most stems will be removed. Carsky and Toukourou (2004) found that litter fall could return quite considerable amounts of N (35–71 kg ha⁻¹) and moderate amounts of K (9–25 kg ha⁻¹) to the soil. Many farmers cultivate local bitter varieties. These varieties can remain in the field for 2–3 years without rotting. Farmers allow these fields to develop into a 'natural' fallow (i.e. no more weeding) after 8–12 months. This practice allows the soil to rest and during this time some nutrients (especially N) can accumulate in the topsoil. Burning will make a large amount of the P and K contained in the vegetation available to the subsequent cassava, but most N will be lost.

Total amounts of nutrients added the root zone depend on the duration of the fallow. Fallows periods in east Africa have reduced due to increasing population pressure. This is especially the case in western Kenya (Mango, 1999). In Uganda, half of the cassava farming systems still allows a fallow period of 2–4 years (Nweke et al., 1999). However, even with such

fallow durations, there is little chance that P and K nutrient stocks are sufficiently being replenished. In addition, grazing is likely to be too scattered and too much affected by losses to be able to make a significant contribution to restoring soil fertility.

Cassava is often grown on soils with low fertility. In western Kenya, farmers intentionally plant cassava on the poorest soils, because they believe that nutrient requirements of cassava are lower than for other crops (Ojiem and Odendo, 1997). This is in line with results from Mango (1999), who observed that when soil degradation becomes widespread, cassava becomes increasingly important in cropping systems in western Kenya. In addition, the COSCA studies (Nweke et al., 1999) have shown that approximately 50% of all cassava in Uganda is cropped in continuous systems that have no fallow to (partially) restore soil fertility levels.

Soil fertility management in banana cropping systems

Cassava is the dominant food crop in eastern and northern Uganda, but banana is so in central and southwest Uganda (Gold et al., 1999). Fresh yield levels of banana systems are similar to what one can expect in a good cassava field (option 3). Like cassava, banana is also a huge consumer of K (Lahav, 1996). At a fruit yield of 25 t ha⁻¹yr⁻¹, banana removes on average some 52 kg N, 5 kg P, and 142 kg K ha⁻¹ yr⁻¹. Banana yields are particularly good (25 t ha⁻¹yr⁻¹ or more) in areas in southwest Uganda (van Asten et al., 2004), where banana fields of 50 years and older are common. This suggests that banana farmers have developed management practices that lead to sustainable production and the maintenance of sufficient soil nutrient stocks. The question is whether banana management strategies can

Table 6. Removal of N, P and K (kg ha⁻¹) at four levels of cassava root yield at A) only roots removed and B) all roots, stems and leaves removed

Scenario	A. Only roots removed			B. Roots, stems and leaves removed		
	N	P	K	N	P	K
I. Local variety 10 t/ha¹	26.2	2.5	19.1	119.5	10.5	52.1
II. Impr. variety 20 t/ha²	55.4	6.0	30.4	155.1	14.4	65.9
III. Impr. variety 30 t/ha²	83.1	9.6	47.4	216.3	21.6	101.5
IV. Impr. variety 40 t/ha²	110.9	13.4	73.9	273.9	28.9	156.2

1. Dry matter content of local varieties is estimated at an average 35% and harvest index at an average 39.
2. Dry matter content of improved varieties is estimated at an average 37% and harvest index at an average 60.

Table 7. Soil fertility practices in cassava fields in Uganda (% of villages)¹

Practice	Near fields	Distant fields
Intercropping with legumes	100	95
Incorporation of residues	59	56
Burning	54	56
Grazing	36	28
Mulching	15	13
Manure	15	3
Chemical fertilizer	5	3

1. Own analysis from original data set of Nweke et al., 1999.

be transferred to cassava fields, in order to maintain soil fertility.

In Uganda, a substantial proportion of the bananas are grown near the homestead (Rufino, 2003). Plots near the homestead generally receive more organic household residues and are often more mulched than plots further away. In a study by Briggs and Twomlow (2002) in southwest Uganda, most farmers (90%) indicated that they considered the closest homestead plot and the banana plantation to be the most important fields on which to apply their manure. Wortmann and Kaizzi (1998), Bekunda and Woome (1996), Baijukya et al. (1998) and Bosch et al. (1996) all found that that homestead/banana plots contain more nutrients (particularly P and K) when compared to annual cropped fields and plots further away from the homestead. Baijukya et al. (1998) quantified nutrient balances for banana cropping systems in northwest Tanzania. They observed neutral to positive nutrient balances in banana fields when farmers possessed cattle (on average 5 heads per farm), due to the nutrient flow from grassland areas to banana fields. However, few farmers in their study used mulch and crop residues. This is in contrast with findings by Bekunda and Woome (1996), who observed that Ugandan banana farmers applied a wide range of additional resources to bananas, including field crop residues (81%), burned residues (3%), on-farm manures (31%), compost (16%), external organic (17%) and chemical (4%) inputs. The majority of farmers also plants intercrops in (part) of the banana fields. Phaseolus beans are the most common intercrop and crop residues are normally left or returned to the field (Bananuka and Rubaihayo, 1994). Wortmann and Kaizzi (1998) quantified nutrient balances of different farm units in central Uganda and found that all nutrient balances were negative except for banana fields, where N and P nutrient balances were marginally positive. Nutrient balances were particularly negative

in annual cropped fields, due to the fact that fertilizer and nutrients in any form (e.g. crop residues) were applied to banana only.

Discussion and conclusions

Local cassava varieties do not seriously deplete soil fertility due to low yields (10 t/ha) and long cropping cycles (2 years). Farmers in Benin, Ghana and Kenya even claim to employ cassava as a sort of fallow to revive soil fertility levels of degraded fields, using either late bulking varieties or high planting densities (Adjei-Nsiah, personal communication; Carsky and Toukourou, 2004; Obiero, 2004). On the other hand, cassava is also known as a 'scavenger crop', capable of removing high quantities of nutrients from the soil, thereby increasing the risk of soil exhaustion (Cock and Howeler, 1978). This appears especially true for the high yielding (20–30 t/ha) improved varieties when all biomass is removed from the field.

There are four reasons to suspect that the introduction of high yielding, improved varieties will pose a serious threat to the sustainability of cassava production systems in the region. These are: (i) high nutrient removal, (ii) small nutrient stocks of most cassava soils, (iii) reduced fallowing, and (iv) no significant replenishment of nutrient stocks (especially K) through addition of (in) organic inputs. Depending on initial soil conditions, nutrient depletion will result in declining yield levels within a few years after introduction of the new varieties. This risk is higher in the continuous farming systems of western Kenya than in Ugandan systems that still allow some fallowing. Farming systems with a high percentage of cassava are particularly at risk, as crops rotated with cassava will be affected by the decreasing soil fertility levels. This concern is being reinforced by the general trend of soil fertility decline, particularly in western Kenya due to increasing land use pressure and the lack of external inputs (Soule and Shepherd, 2000).

To prevent (accelerated) soil fertility decline due to the introduction of high yielding cassava varieties, their introduction should be accompanied by appropriate soil and crop management practices. Banana farmers in Uganda have shown that proper management can sustain high yield and soil fertility levels for several decades, even when no inorganic fertilizers are used. However, cassava takes a very different position in the farming system as banana (i.e., annual crop, mostly

grown in distant plots). For that reason, the soil fertility practices used for banana fields will probably not be adopted for cassava fields. Nonetheless, various options are available to maintain soil fertility, depending on the objectives and characteristics of the production system.

Low-input systems

In low-input systems without a readily available market for cassava, planting densities of the improved varieties can be reduced to match subsistence requirements and reduce nutrient removal. This can be combined with the introduction of leguminous grain legumes with a positive N balance (groundnut, soyabean, cowpea). Another option is to concentrate cassava production for subsistence needs on a smaller area. This can be combined with an increase in the proportion of the farm under legumes with a positive N balance. The farmer practice of allowing a cassava field to develop into a fallow can be improved by the introduction of improved fallow species. This system could be adapted to continuous cropping systems by the introduction of a relay leguminous cover crop in the second rainy season. The use of legumes as an inter- or relay cover crop allows one to actually use the cassava field as an entry point to improve soil fertility for subsequent crops. In areas where a considerable part of the available farm land is dedicated to cassava, soil fertility management in cassava fields may contribute significantly to the overall fertility and sustainability of the farming systems.

Moderate-high input systems

In areas without a stable cassava market, farmers are not likely to use inputs in their cassava fields to maintain soil fertility levels. This implies that one can better manage soil fertility on the farm level through practices that aim at increasing yields of the other crops in the production system, rather than targeting cassava directly. This can be achieved by increasing the percentage of promiscuous legumes in the system and/or targeted fertilizer usage to cash crops. Cassava grown in rotation with fertilized cash crops or intercropped with fertilized cash crops will benefit from the applied nutrients. The use of small applications of P has been shown to increase the N contribution of grain legumes to the soil (Giller, 2001). However, the depletion of soil K stocks will remain a serious concern in these systems

as K fertilizer is hardly used on the commonly fertilized crops as maize, sugarcane and legumes.

Intensive cassava systems

The high yield levels of the new cassava varieties have already triggered its promotion as a cash crop in Uganda. Provided that there is a good (industrial) market outlet, farmers can be motivated to use targeted organic & inorganic fertilizer dosages to prevent soil fertility depletion and maintain high cassava yields. However, initial results from agronomic trials (unpublished data Fermont, Obiero, Baguma and Okwuosa) seem to indicate that many improved varieties are not responding to fertilizer usage. This is due to the fact that cassava breeding in East Africa was always conducted at non-fertilized plots, creating varieties that are sturdy in a large range of conditions, but that do not give an optimal response to fertilizer usage.

Acknowledgements

The authors wish to thank IITA, NARO and KARI for their support of this work and the Dutch Ministry of Foreign Affairs for financing A. Fermont's position.

References

- Andriess W. and van der Poum B.J.A. 1985. Reconnaissance soil map of the lake basin development authority area, western Kenya (1:250000). Netherlands soil survey institute / Kenya soil survey. Wageningen / Nairobi.
- Anonymous 1999. Annual report Busia district 1998. Ministry of Agriculture, Republic of Kenya.
- Anonymous 1998. Annual report Siaya district 1997. Ministry of Agriculture, Republic of Kenya.
- Baijukya F.P. and de Steenhuijsen Piters B. 1998. Nutrient balances and their consequences in the banana-based land use systems of Bukoba district, northwest Tanzania. *Agric. Ecosyst. Envir.* 71: 147–158.
- Bananuka J.A. and Rubaihayo P.R. 1994. Banana management practices and performance in Uganda. *Afr. Crop Sci. Conf. Proc.* Vol. 1. African Crop Science Society, Uganda. 177–182.
- Bekunda M.A. and Woome P.L. 1996. Organic resource management in banana-based cropping systems of the Lake Victoria Basin, Uganda. *Agric. Ecosyst. Envir.* 59: 171–180.
- Bosch C., Lorkeers A., Ndile M.R. and Sentozi E. 1996. Diagnostic survey: constraints to banana productivity in Bukoba and Muleba districts, Kagera region, Tanzania. Working paper no. 8. Tanzania/Netherlands Farming Systems Research Project, Lake Zone. ARI Muruku, Bukoba, Tanzania. 119pp.

- Braun A.R., Smaling E.M.A., Muchugu E.O., Shepherd K.D. and Corbett J.D. 1997. Maintenance and improvement of soil productivity in the highlands of Ethiopia, Kenya, Madagascar and Uganda. *AHI*. Nairobi.
- Bua A., Otim-Nape G.W., Acola G., Baguma Y. 1997. The approaches adopted and the impact of cassava multiplication in Uganda. In: Otim-Nape G.W., Bua A., Thresh J.M. (eds.), *Progress in cassava technology transfer in Uganda*. NARO, GCF & NRI. Chatham, pp. 78–92.
- Carsky R.J. and Toukourou M.A. 2004. Importance of cassava leaf litter dry matter and its estimation. *Exp. Agric.* In press.
- Cock J.H. and Howeler R.H. 1978. The ability of cassava to grow on poor soils. In: Jung G.A. (ed.), *Crop tolerance to suboptimal land conditions*, ASA special publication no. 32, Am. Soc. of Agr. Wisconsin. 145–154.
- FAO, 2004. www.apps.fao.org
- Foster H.L. 1981. The basic factors which determine inherent soil fertility in Uganda. *J. Soil Sci.* 32: 149–160.
- Fresco L.O. 1993. The dynamics of cassava in Africa; an outline of research issues. COSCA working paper No. 9. IITA, Ibadan.
- Fresco L.O. 1986. Cassava in shifting cultivation; A systems approach to agricultural technology development in Africa. Royal Tropical Institute, Amsterdam.
- Giller K.E. 2001. Nitrogen fixation in tropical cropping systems, CABI, Wallingford.
- Gold C.S., Karamura E.B., Kiggundu A., Bagamba F. and Abera A.M.K. 1999. Geographic shifts in highland cooking banana (*Musa* spp., group AAA-EA) production in Uganda. *Int. J. Sust. Agric. World Ecol.* 6: 45–59.
- Hilhorst T. and Muchena F.M. 2000. Nutrients on the move – Soil fertility dynamics in African farming systems. IIED. London.
- Hillocks R.J. 2002. Cassava in Africa. In: Hillocks R.J., Thresh J. M. and Bellotti A.C. (eds.) *Cassava: Biology, Production and Utilization*. CABI, Wallingford, pp. 41–54.
- Howeler R.H. 2002. Cassava mineral nutrition and fertilization. In: Hillocks R.J., Thresh J.M. and Bellotti A.C. (eds.) *Cassava: Biology, Production and Utilization*. CABI, Wallingford, pp. 115–147.
- Jaetzold R. and Schmidt H. 1983. *Farm management handbook of Kenya*, vol. III, west Kenya. Ministry of Agriculture, Nairobi.
- Jones E. 1972. Principles of using fertilizers to improve red Ferrallitic soils in Uganda. *Exp. Agric.* 8: 315–332.
- Lahav E. 1996. Banana nutrition. In: Gowen S. (Ed.), *Bananas and Plantains*, NRI and University of Reading, Depart. of Agric., United Kingdom, pp. 258–316.
- Legg J.P., Bua A., Sserubombwe W., Sseruwagi P. and Thresh M.J. 2004. The incidence and severity of cassava mosaic virus disease and the varieties of cassava grown in six districts of Uganda, 1990–2003. Submitted to journal of phytopathology.
- Leihner D. 1983. Management and evaluation of intercropping systems with cassava. CIAT. Colombia.
- Mango N.A.R. 1999. Integrated soil fertility management in Siaya district, Kenya. *Managing Africa's Soils* No. 7.
- NAARI 2000. Annual report Namulonge Agricultural and Animal Research Institute 1999–2000. Namulonge.
- NAARI 1998. Annual report Namulonge Agricultural and Animal Research Institute 1997–1998. Namulonge.
- NAARI 1997. Annual report Namulonge Agricultural and Animal Research Institute 1996–1997. Namulonge.
- NARO 2003. On-farm evaluation of cassava mosaic disease resistant varieties in Teso and Lango farming systems. National Agricultural Research Organization/DFID CORF45 Terminal Report. Namulonge.
- Nweke F.I., Otim-Nape G.W., Dixon A.G.O., Asadu C.L.A., Bua A., Ajoba O., Ugwu B.O., Baguma Y. and Masembe-Kajubi H. 1999. Production prospects for cassava in Uganda. COSCA working paper 17. IITA. Ibadan.
- Nweke F.I., Dixon A.G.O., Asiedu R. and Folayan S.A. 1994. Cassava varietal needs of farmers and the potential for production growth in Africa. COSCA working paper 10, IITA, Ibadan.
- Obiero H.M. 2004. Accelerated cassava multiplication and distribution of improved planting materials in western Kenya. In: Emergency program to combat the cassava mosaic disease pandemic in east and central Africa. Proceedings of the Fifth regional stakeholders meeting, Bukoba, Tanzania, September 10-12, 2003, pp 15–23.
- Ojiem J.O. and Odendo M.O. 1997. Farmer's perception of spatial heterogeneity and its influence on soil management in small-scale farms in western Kenya. *African Crop Science Conference Proceedings* 3: 282–287.
- Otim-Nape G.W., Bua A., Thresh M.J., Baguma Y., Ogwal S., Ssemakula G.N., Acola B., Byabakama B., Colvin J., Cooter. R.J. and Marin A. 2000. The current pandemic of cassava mosaic virus disease in East Africa and its control. NRI, Chatham.
- Rufino M. 2003. On-farm Analysis of Nematode Infestation and Soil Fertility as Constraints to the Productivity of Banana-based Production Systems in Uganda. MSc Thesis. Plant Sciences, Wageningen University. The Netherlands. 91pp.
- Soule M.J. and Shepherd K.D. 2000. An ecological and economic analysis of phosphorus replenishment for Vihiga division, western Kenya. *Agric. Ecosyst. Environ.* 64: 83–98.
- Ssemakula G.N., Bua A., Tumwesigye S., Baguma Y., Sserubombwe W., Omongo C. and Alicai T. 2000. Application for release of new cassava varieties. Cassava program, NAARI. Kampala.
- Stoorvogel J.J. and Smaling E.M.A. 1990. Assessment of soil nutrient depletion in sub-Saharan Africa: 1983-2000, vol 1: Main report. Report No. 28, Winand Staring Centre, Wageningen.
- van Asten P.J.A., Gold C.S., Wendt J., De Waele D., Okech S.H.O., Ssali H. and Tushmireirwe W.K., 2004. The contribution of soil quality to banana yield problems and its relation with other banana yield loss factors. *Afric. Crop Sci. J.*, in press.
- Van den Bosch H., Gitari J.N., Oguro V.N., Maobe S. and Vlamming J. 1998. Monitoring nutrient flows and economic performance in African farming systems (NUTMON). III. Monitoring nutrient flows and balances in three districts in Kenya. *Agric. Ecosyst. Environ.* 71: 63–80.
- Wortmann C.S. and Kaizzi C.K. 1998. Nutrient balances and expected effects of alternative practices in farming systems of Uganda. *Agric. Ecosyst. Environ.* 71: 115–129.

Partial balance of nitrogen in a maize cropping system in humic nitisol of Central Kenya

J.M. Kimetu^{1,7,*}, D.N. Mugendi², A. Bationo¹, C.A. Palm³, P. K. Mutuo⁴, J. Kihara¹, S. Nandwa⁵ and K. Giller⁶

¹Tropical Soil Biology and Fertility Institute of CIAT, (TSBF-CIAT), P.O. Box 30677, 00100 Nairobi, Kenya; ²Department of Environmental Foundations, Kenyatta University, P.O. Box 43844, Nairobi, Kenya; ³The Earth Institute at Columbia University, P.O. Box 1000, 117 Monell Building, 61 Route 9W, Lamont Campus, Palisades, New York 10964-8000, USA; ⁴World Agroforestry Centre (ICRAF), P.O. Box 30677, Nairobi, Kenya; ⁵National Agricultural Research Laboratories (NARL), P.O. Box 14733, Nairobi, Kenya; ⁶Department of Plant Sciences, Plant Production Systems, Wageningen University, Wageningen, The Netherlands; ⁷Department of Crop and Soil Science, 1022 Bradfield Hall, Ithaca, NY 14853, Cornell University, USA; *Author for correspondence (e-mail: jmk229@cornell.edu; J.Kimetu@cgiar.org; phone: +254-722-569207 or +1 607 255 2283; fax: +254-20-7224763)

Key words: Emissions, N leaching, N loss, N recovery, Nitrous oxide

Abstract

The application of nitrogen in a soil under agricultural production is subject to several pathways including de-nitrification, leaching and recovery by an annual crop. This is as well greatly influenced by the management practices, nitrogen source and soil conditions. The main objective of this study was to investigate the loss of nitrogen (N) through nitrous oxide (N₂O) emissions and mineral N leaching and uptake by annual crop as influenced by the N source. The study was carried out at Kabete in Central Kenya. Measurements were taken during the second season after two seasons of repeated application of N as urea and *Tithonia diversifolia* (tithonia) leaves. Results obtained indicated that nitrous oxide (N₂O) emissions at 4 weeks after planting were as high as 12.3 $\mu\text{g N m}^{-2} \text{h}^{-1}$ for tithonia treatment and 2.9 $\mu\text{g N m}^{-2} \text{h}^{-1}$ for urea treatment. Tithonia green biomass treatment was found to emit N₂O at relatively higher rate compared to urea treatment. This was only evident during the fourth week after treatment application. Soil mineral N content at the end of the season increased down the profile. This was evident in the three treatments (urea, tithonia and control) investigated in the study. Urea treatment exhibited significantly higher mineral N content down the soil profile (9% of the applied N) compared to tithonia (0.6% of the applied N). This was attributed to the washing down of the nitrate-N from the topsoil accumulating in the lower layers of the soil profile. However, there was no significant difference in N content down the soil profile between tithonia treatment and the control. It could be concluded that there was no nitrate leaching in the tithonia treatment. Nitrogen recovery by the maize crop was higher in the urea treatment (76% of the applied N) as compared to tithonia treatment (55.5% of the applied N). This was also true for the residual mineral N in the soil at the end of the season which was about 7.8% of the applied N in the urea treatment and 5.2% in the tithonia treatment. From this study, it was therefore evident that although there is relatively lower N recovery by maize supplied with tithonia green biomass compared to maize supplied with urea, more nitrogen is being lost (through leaching) from the soil-plant system in the urea applied plots than in tithonia applied plots. However, a greater percentage (37.8%) of the tithonia-applied N could not be

This article has been previously published in the journal "Nutrient Cycling in Agroecosystems" Volume 76 Issues 2–3.

accounted for and might have been entrapped in the soil organic matter unlike urea-applied N whose greater percentage (92%) could be accounted for.

Introduction

In addition to the nitrogen that is either recovered by an annual crop or retained in the soil at the end of a growing season, significant amount of nitrogen (N) is lost directly or indirectly from both organic materials and mineral fertilizers when applied to the soil. Some of the major processes through which N is lost from the plant–soil system include denitrification, leaching, and volatilization. In addition to the prevailing edaphic and climatic conditions, the management systems also influence these processes that govern nitrogen loss from the soil–plant system in both agricultural and agroforestry systems (Dixon 1995). There is little information on the magnitude of N₂O emissions and N leaching in tropical soils under different management regimes and soil types. Due to the high mobility of nitrogen in the soil, these losses in turn influence uptake by annual crops. Therefore, this study was aimed at providing estimates of nitrogen (N) losses through nitrous oxide (N₂O) emissions and mineral N leaching and uptake by annual crop as well as soil N at the end of a growing season as influenced by the N source.

Some of the pathways through which N is lost in different forms include the following:

Denitrification

This refers to nitrate reduction to gaseous nitric oxide (NO), nitrous oxide (N₂O) or dinitrogen gas (N₂) and this mainly takes place under anaerobic conditions (Babbar and Zak 1996) through several bacteria (Loomis and Connor 1992; Singh and Vaje 1998; Brady and Weil 1999) resulting in a net N loss from the system. These N gas losses can be reduced significantly through better soil and fertilizer management. Lehmann et al. (1999) reported that the rate of N loss was lower with mulches compared to inorganic N source and attributed their findings to microclimate amelioration by the organic material. They also observed higher rates of N loss with application of ammonium sulphate [(NH₄)₂SO₄] fertilizer compared to

Acacia saligna mulches in a study in the dry tropical savanna of northern Kenya. Matson et al. (1998), working on wheat in Mexico, found that a reduction of gaseous loss of N from about 14 kg N ha⁻¹ to almost zero could be attained by improved system management. This depicts that organic inputs can be used to minimize gaseous N losses. However, other studies have shown higher denitrification losses with organic as compared to mineral fertilizers (Janzen and Schaalje 1992). More research to ascertain this is needed especially for different agroecological zones and soil types.

Volatilization

Nitrogen loss in the form of ammonia gas and its volatilization is mainly a soil surface phenomenon that is more pronounced in alkaline environments (Glasener and Palm 1995; Palm et al. 1996; Singh and Vaje 1998). Loomis and Connor (1992) noted that at pH 5.0 and below, about 0.004% of the nitrogen is present as free NH₃ but that fraction increases approximately 10-fold with each unit increase in pH. Thus at pH 9.0, about 40% of the total nitrogen available in form of NH₃ is volatilized. When urea fertilizer is applied to the surface of agricultural soils of pH > 7.0 especially in arid and semi-arid regions, NH₄⁺ formed from urea is deprotonized to form NH₃ gas (Terman 1979; Patra et al. 1996). This NH₃ gas readily diffuses into the atmosphere causing reasonable losses of the urea applied nitrogen. Kumar et al. (1994) quoted by Lehmann et al. (1999) noted considerable reduction in NH₃ losses by application of *Sesbania aculeata* leaves as compared to mineral fertilizer application. Glasener and Palm (1995) found a maximum of 11.8% N loss via volatilization on a soil with pH 4.5. This was reduced to zero with incorporation of the organic materials.

Leaching

Nitrogen applied or fixed into the soil is not all taken up by plants; a large amount is incorporated

into the soil organic matter, lost to the atmosphere as discussed earlier or leached into the ground or surface waters (Di and Cameron 2002). Significant amounts of soil organic nitrogen are also mineralized, which are then taken up by plants, lost to the atmosphere or leached down the soil profile (Kimetu 2002). Nitrogen loss through leaching mainly occurs with increased accumulation of nitrates in the soil profile followed by a period of high drainage. Due to the fast conversion of ammonium to nitrate, the concentration of nitrates is higher than ammonium in most soils. Therefore, because soils are mainly negatively charged, nitrates are loosely held in the soil hence can readily be leached down the profile.

Nitrate leaching and water contamination have become a major concern worldwide. This has been due to intensification of agricultural production involving the application of nitrogen fertilizers (Spalding and Exner 1993; Addiscott 1996; Di and Cameron 2002). Although this problem is more pronounced in the developed countries, rising nitrate concentration in groundwater have also been detected in some regions of developing countries where agricultural production has intensified with increased use of both chemical fertilizer and organic fertilizers (Di and Cameron 2002).

Management options to mitigate leaching of nitrates include: reducing N application rates, synchronizing N supply to plant demand, use of cover crops, better timing of ploughing pasture leys, improved stock management and precision farming (Di and Cameron 2002).

The pathways highlighted above and others like crop harvesting and runoff have been noted to be the principal ways through which about 89% of the N applied in the soil is lost (Peoples et al. 1995). Most annual crops are capable of recovering only about 20–50% of the N applied (Paroda et al. 1994) or lower (Mugendi et al. 2000) depending on the form in which the fertilizer is applied (inorganic or organic). More research is needed to establish the amount of N lost through each of the pathways and work on ways and means of minimizing this loss.

The objective of this study was to investigate the loss of nitrogen (N) through nitrous oxide (N₂O) emissions and mineral N leaching and uptake by annual crop as influenced by the N source.

Materials and methods

Site description

The study was carried out at the National Agricultural Research Laboratories (NARLs) station at Kabete, Kenya which is located at 36° 46' E and 01° 15' S and an altitude of 1650 m above sea level. The soils are mainly Humic Nitisols (FAO 1990) that are deep and well weathered. The soil pH is 5.4, total N 1.35 g kg⁻¹, extractable P 27 mg kg⁻¹, carbon 1.6%, exchangeable Ca, Mg, and K (cmol kg⁻¹) 5.8, 1.7, and 0.7 respectively, clay 40%, sand 23%, and silt 37%. The mean annual rainfall is about 950 mm received in two distinct rainy seasons; the long rains (LR) received between mid-March and June, and the short rains (SR) received between mid-October and December. The average monthly maximum and minimum temperature is 23.8 °C and 12.6 °C, respectively.

Nitrogen (N) recovery, N losses through N₂O emissions and N leaching were compared from application of *Tithonia diversifolia* (tithonia) green manure or urea, both applied at 60 kg N ha⁻¹. Organic materials (freshly collected leaves of tithonia) were applied at the beginning of the season, broadcasted and incorporated by hand in the top 10 cm of soil prior to planting. Urea was applied according to normal practice (split application); a third of the total amount was applied before planting while two-thirds was applied 5 weeks after planting. This was by broadcasting and incorporating up to about 10 cm depth. The calculation of the application amount of organic materials (that would give 60 kg N ha⁻¹) was done on dry matter basis. The maize variety planted was hybrid 512. The experiment, which was designed and established by TSBF in 1999, consisted of 10 treatments replicated four times (Kimetu et al. 2004). The treatments sampled for N₂O, N leaching and N recovery were tithonia treatment, urea treatment and the control.

Sampling and analyses

Measurements were taken during the second season (2000 long rains which occur between March and June) after two seasons of repeated applica-

tion of N as urea and *Tithonia diversifolia* (tithonia) leaves.

Gas sampling

The three treatments (tithonia, urea and control) each replicated four times were sampled for gas analyses. This was done before treatment application, 1 week, and 4 weeks after treatment application. Plastic chambers with internal diameter of 30.5 cm and a height of 10 cm were used for measuring gas fluxes. The top of each chamber had a brass-sampling valve fitted with a teflon septa. A base was constructed using polyvinylchloride (PVC) tubes about 6 cm in height where one end was expanded to enable the chamber to fit tightly. The bases were driven to a depth of 3 cm in the soil 24 h before gas sampling to ensure that disturbed soil had settled (Puget and Drinkwater 2001). At the beginning of each sampling period the chamber was placed into the permanent PVC base. A hole was opened in the chamber's top during placement to avoid creating over-pressure, a rubber bung was placed in the hole once the chamber was situated in the permanent base. Samples were collected from the chamber headspace with 50 ml polypropylene syringes at 0, 10, 20, and 40 min following chamber closure. Thirty milliliters of each sample was injected into 20 ml evacuated glass vials (Labco Exetainer). The vials sampled were properly labeled with plot descriptions and time of sampling and then sent to USDA/ARS laboratory in Fort Collins, CO, USA and analyzed by gas chromatography. Nitrous oxide (N₂O) was analyzed by electron capture detector (ECD) (Matson and Harriss 1995).

0.7. Using the slopes (D_y) of the lines (concentration versus time), the fluxes were calculated as:

$$\text{N}_2\text{O flux} = D_y * 7027.2$$

The above calculations assumed a standard pressure (1 atm.) and standard temperature of 20 °C or 293 K, therefore, corrections for pressure and temperature were made as follows (Source: Matson and Harriss 1995):

$$\text{Flux (corrected)} = \text{Gas flux} * \frac{[\text{Pressure (bars)/1.013}]}{[\text{Temperature (K)/293}]}$$

Nitrogen uptake

Nitrogen uptake by the maize crop was determined at the end of the growing season. N uptake was calculated by multiplying the grain, stover and core (husk) yields with the nitrogen concentration in the specific components. Analysis was done on grain and stover samples for total N by Kjeldahl digestion with concentrated sulfuric acid (Anderson and Ingram 1993; ICRAF 1995). The nitrogen concentration in the core was estimated from the values obtained from the stover samples. This is because, earlier research by Gachengo (unpublished data and personal communication) revealed that the nutrient contents in the stover were almost similar to concentrations of the same nutrients in the core. Mugendi (1997) also observed the same in his study in the subhumid highlands of Kenya.

Nitrogen recovery was determined as shown below:

$$\text{Nitrogen recovery (\%)} = \frac{(\text{Nitrogen uptake}_{\text{treatment}} - \text{Nitrogen uptake}_{\text{control}})}{\text{Amount of nitrogen applied}} \times 100$$

Gas analyses

To determine nitrous oxide emission in the different treatments, the following procedure was used:

Gas concentrations in parts per million (ppm) were plotted against time (0, 10, 20, and 40 min) for each chamber. The four replicates were plotted in one graph. The out-liers were eliminated where necessary to obtain an R^2 of the fitted line of above

Soil sampling and analyses

Soil N availability and movement: Soil N dynamics, both in terms of N availability in the topsoil and N movement through the profile were determined by consecutive soil samplings through the cropping season. At the end of the season, control, tithonia and urea treatments were sampled up to 180 cm depth for mineral N (NH₄⁺ and NO₃⁻)

determination at different depths (0–10, 10–30, 30–60, 60–90, 90–120, 120–150 and 150–180 cm). This enabled determination of N dynamics down the soil profile. Soil moisture content was determined and the values used in the calculation of mineral N content in the soil. Soil extraction was done by shaking about 20 g of soil in 125 ml bottles for 1 h in 100 ml of 2 N KCl (ICRAF 1995). The extract was filtered through Whatman paper (no. 5). The filtrates were then analyzed for extractable nitrate by cadmium (Cd) reduction column method (Anderson and Ingram 1993; ICRAF 1995) and for extractable ammonium using colorimetric method (ICRAF 1995).

The effects of treatment on gas fluxes and N leaching were determined separately for each experiment using Genstat 5 for windows (Release 4.1). Treatment means found to be significantly different from each other were separated by least significant differences (LSD) at $p \leq 0.05$.

Results and discussion

Treatment effects on nitrous oxide emissions

Missing out the second split of the urea application might limit any concrete conclusion on the amount of N lost through N_2O emission in the present study. Nevertheless the study reveals some intrinsic facts about N_2O flux with organic input versus synthetic fertilizer inputs as highlighted below.

Nitrous oxide (N_2O) emissions differed significantly with sampling time in tithonia fertilized plots. The range was as low as $-0.3 \mu\text{g N m}^{-2} \text{h}^{-1}$ (before treatment application) and as high as

$12.3 \mu\text{g N m}^{-2} \text{h}^{-1}$ (4 weeks after application) (Table 1). Urea treatment did not show any significant difference between the three sampling periods (before treatment application, 1 week and 4 weeks after application). This was also true with the control.

There was no significant difference in nitrous oxide flux between tithonia and urea treatments before treatment application and one week after application. The amount of N_2O emitted from tithonia treatment one week after treatment application was about $2.4 \mu\text{g m}^{-2} \text{h}^{-1}$ while N_2O emission in urea treatment was $2.9 \mu\text{g m}^{-2} \text{h}^{-1}$.

At four weeks after treatment application, there was significant difference in N_2O emission between tithonia and urea treatments (Table 1). The rate of N_2O emission in tithonia treatment was $12.3 \mu\text{g m}^{-2} \text{h}^{-1}$ as compared to urea treatment which emitted at the rate of $1.3 \mu\text{g m}^{-2} \text{hr}^{-1}$. The relatively lower N_2O emissions in urea treatment could be attributed to split application of the mineral fertilizer. Palm et al. (1997) reported relatively large amounts of N losses from sole application of high quality organic materials as compared to mineral fertilizer alone. Thus, a better option (than the use of either organic or mineral fertilizer alone) could be the use of high quality organics as partial substitution for synthetic fertilizers.

The relatively higher N_2O emissions in the green manure treatment as compared to synthetic fertilizer treatment could be attributed partially to the incorporation of the green manure leaves which promoted high levels of nitrate and available carbon in the soil enhancing denitrification (Janzen and Schaalje 1992). Xu et al. (1993) and Jones et al. (1997) reported

Table 1. Treatment effects on N_2O fluxes at, Kabete, Kenya, 2000.

Treatment	N rate (kg N ha ⁻¹)	Nitrous oxide (N_2O) flux ($\mu\text{g m}^{-2} \text{h}^{-1}$)			
		T0	1WAP	4WAP	Lsd _{0.05}
Control	0	1.7	1.2	7.3	11.2
Tithonia	60	-0.3	2.4	12.3	5.4
Urea	20	0.6	2.9	1.3	8.8
Lsd _{0.05}	NA	8.0	3.2	9.4	-

Note. Only 20 kg N ha⁻¹ of urea had been applied at the time of the gas sampling; 40 kg N ha⁻¹ was applied at 5 weeks after planting (1 week later).

Abbreviations. T0, before treatment application; WAP, week(s) after treatment application.

higher losses of N through denitrification when the material is incorporated compared to surface application.

Nitrogen uptake and total %N recovery by maize

Results obtained at the end of the maize growing season revealed that nitrogen concentrations in the grain, stover and core yields differed significantly ($p \leq 0.05$) between the different treatments (Table 2). Nitrogen uptake ranged from 86.3 to 131.9 kg ha⁻¹. Urea treatment gave the highest N uptake while control had the lowest. Total N uptake in the above ground yield from urea sole application was 45.6 kg ha⁻¹ higher than in control plots. This relatively high N uptake from urea treatment could be attributed to the readily available N from the urea. The N uptake by maize that received tithonia green biomass alone as N source was about 119.6 kg ha⁻¹, which was not significantly different from the control.

Nitrogen recovery by the maize crop that received urea was significantly higher compared to nitrogen recovered by maize that received only tithonia green biomass. The apparent percentage N recovery by maize crop that received only tithonia green biomass was 55.5% while urea treatment had 84.7% nitrogen recovery. Other researchers working on different N sources (organic inputs and synthetic inputs) also reported a percentage N recovery ranging from 25% to 111% (Westerman et al. 1972; Kruijs et al. 1988; Christianson et al. 1990; Gachengo et al. 1999; Rees and Castle 2002). The high N recovery by maize crop planted with sole urea was an indication that there

was less N loss from soil–plant system. Therefore, the growing maize crop took up a large percentage of the N supplied by either the synthetic or organic inputs. Nitrogen recovery by annual crops can vary widely depending on biophysical conditions, but is generally thought to be low for organic inputs. Giller and Cadisch (1995) suggest that for most organic inputs, this can be about 20% and in some cases up to 25% when high quality organic materials like tithonia is used as N source (Gachengo et al. 1999). However N recovered from the tithonia-treated plots in the present study was 55.5% which is relatively higher compared to earlier studies by other researchers (Gachengo et al. 1999). This could partially be explained by the residual effect from a previous season which is not discussed in this study or difference in biophysical factors like rainfall and soil type which could influence nutrient uptake by crop and loss from the plant–soil system.

From this study, it was also noted that, grain yield accounted for a greater portion of the recovered N than either stover yield or the core. This was also noted by Mugendi et al. (2000) in their work in the sub-humid highlands of Kenya. N recovery value from the urea applied maize agrees with the findings of Chabrol et al. (1988) in a study in Bedfordshire, England as well as what Mugendi et al. (1999) found out in their studies in the subhumid highlands of Kenya.

Mineral N leaching at the end of the season as influenced by the N source

Soil mineral N movement down the soil profile was also investigated at the end of the season and

Table 2. Nitrogen added, total aboveground nitrogen uptake, and nitrogen recovery by maize crop (2000) at NARL, Kabete, Kenya.

Treatment	N applied (kg N ha ⁻¹)	Nitrogen uptake (kg ha ⁻¹)	%N		Total %N recovery
			Grain	Stover	
Control	0	86.3	1.7	0.63	N/A
Tithonia	60	119.6	1.8	0.8	55.5
Urea	60	131.9	2.0	1.1	76.0
Lsd _{0.05}	N/A	41.0	–	–	N/A

Note. This sampling was done at the end of the season and the second urea spilt urea had been applied giving a rate of 60 kg ha⁻¹. Calculated total %N recovery values obtained in the study were meant to be estimates to the actual recoveries because the material used were unlabeled.

the results revealed significantly higher mineral N content in urea treatment as compared to control and tithonia treatments (Figure 1). This was evident at different layers up to the depth of about 100 cm and could be attributed to leaching of the applied urea N down the soil profile. This was because during this season adequate rainfall was received thus, providing enough water to percolate down the soil profile hence washing down of the soil loosely held nitrate-N to lower layers (Singh and Vaje 1998). At 20 cm depth, soil mineral nitrogen was about 3.6 mg kg^{-1} higher in urea treatment compared to tithonia treatment while at 75 cm depth this difference increased to about 4.5 mg kg^{-1} . This could be as a result of leaching of the nitrate N (Hagedorn et al. 1997).

At depth lower than 100 cm, no significant treatment differences were noted in the mineral N content.

The relatively lower mineral N content in tithonia treatment as compared to urea treatment down the soil profile was an indication of lower rate of N leaching when tithonia green biomass is used as N source as compared to the use of urea. As shown in Table 3, the use of tithonia biomass however is not an assurance of zero N leaching but could help in reducing the rate of N leached. As

noted by Di and Cameron (2002), in organic farming systems, the lack of chemical N fertilizer use would lead to lower N leaching loss. Therefore, farmers could be encouraged to engage in more of organic farming with the use of organic resources like tithonia green biomass to lower N losses through leaching.

Mineral N in the top soil at the end of the season at Kabete, Kenya, 2000

At the end of the season, the mineral nitrogen that remained in the soil at 10 cm depth soil was highly depended on the treatment (Figure 2). Results indicated that the separate application of the different N sources (tithonia or urea) had significantly different levels of influence on mineral N content in the soil. Urea had the highest mineral N content (8.2 mg kg^{-1}) followed by tithonia sole application with 6.7 mg kg^{-1} while control treatment had the lowest mineral N content (3.9 mg kg^{-1}). The relatively higher mineral N content in the urea treatment might be partially explained by the split application of the urea. This could be an indication that all the urea applied in the second split was not full utilized by the maize.

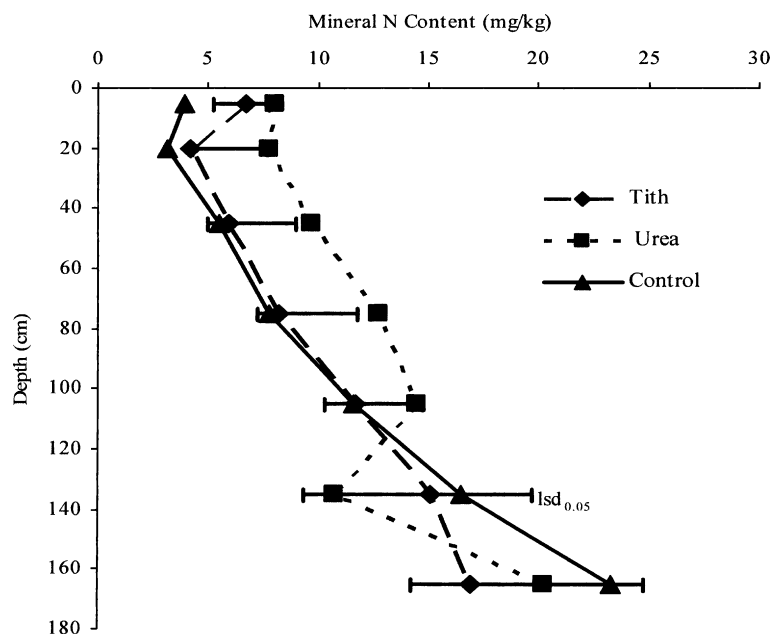

Figure 1. N dynamics down the soil profile – End of 2000 long rain season at NARL, Kabete, Kenya.

Table 3. Nitrogen balance sheet after a maize cropping season at Kabete, Kenya, 2000.

Treatment	Control	Tithonia	Urea	Lsd _{0.05}
N applied (kg ha ⁻¹)	0	60	60	–
Nitrogen lost through leaching (at 70–80 cm depth) (kg ha ⁻¹)	8.6	9.0 (0.4)	14.0 (5.4)	4.6
N lost through nitrous oxide emission at 4WAP (kg ha ⁻¹) per year	0.64	1.10 (0.5)	0.11 (–0.5)	0.8
N recovered by the maize crop (kg ha ⁻¹)	86.3	119.6 (33.3)	131.9 (45.6)	41.0
Mineral N remaining in the top 10 cm soil layer (kg ha ⁻¹)	4.3	7.4 (3.1)	9.0 (4.7)	3.4
N accounted for (kg ha ⁻¹)	99.8	137.1 (37.3)	155.0 (55.2)	–
N not accounted for (kg ha ⁻¹)	–	22.7	4.8	–

Values in parenthesis are net values relative to the control.

Mineral N content available in the soil before the start of the experiment was 17.6 kg ha⁻¹.

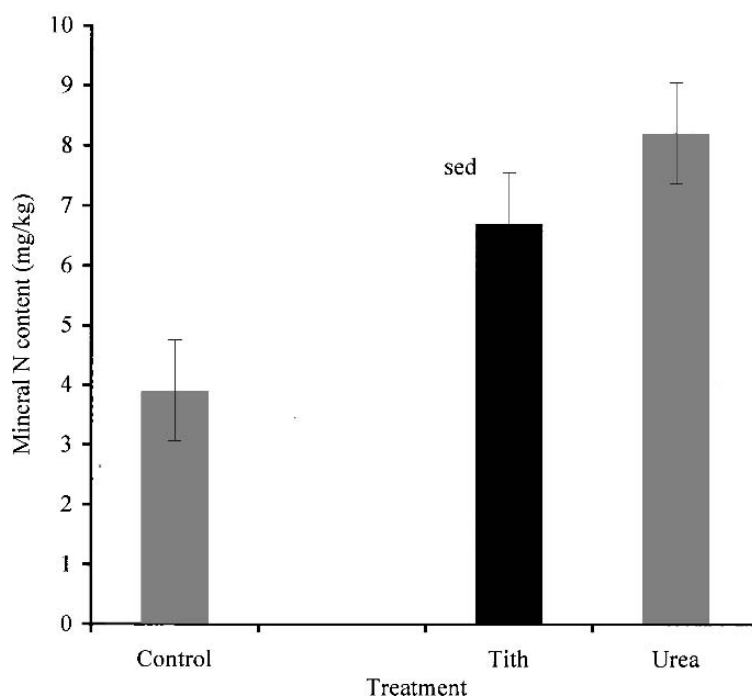

Figure 2. Treatment effect on soil mineral N at the end of 2000 long rains season at 10 cm depth at NARL, Kabete, Kenya.

N budgets at Kabete, Kenya, 2000

Nitrogen lost through leaching in *Tithonia diversifolia* treatment was only 0.4 kg N ha⁻¹ above control treatment which represent 0.7% of the applied N while N loss in urea treatment was 5.4 kg N ha⁻¹ above control representing 9.0% of the applied N (Table 3). This was an indication that more N was being lost through leaching in urea treatment compared to tithonia treatment as already discussed in an earlier section.

Nitrogen loss through nitrous oxide emission was relatively higher with the application of tithonia while urea had relatively lower losses. This could be attributed to the split application of urea. Only 20 kg N ha⁻¹ had been applied at four weeks after planting (4WAP). This was an indication that the use of tithonia green biomass as a source of nitrogen could not be considered as a way for reducing N loss through nitrous oxide (N₂O) emission due to the one-time application practice for the green manure. A possible alternative could

be split application of the green manure but more research is needed to ascertain such a hypothesis. However, missing out the second split of the applied urea in this study limits a concrete conclusion as mentioned earlier.

Maize crop fertilized with tithonia recovered 33.3 kg ha⁻¹ above control which represent 55.5% of the applied N while maize fertilized with urea was able to recover 45.6 kg ha⁻¹ (76% of the applied N). The relatively lower N recovery rate from the tithonia biomass could partially be attributed to the lack of synchrony between N demand by the maize crop and the N released by the decomposing biomass (Mugendi et al. 2000). Urea treatment had the highest amount of mineral N left in the top 10 cm soil (4.7 kg ha⁻¹ above control) while tithonia treatment had 3.1 kg ha⁻¹ above control treatment left in the top 10 cm soil.

Out of this study, we were able to account for 92% of the urea applied N and 62.2% of the tithonia applied N. The decomposition of the tithonia biomass may have led to N retention in soil organic forms that are resistant to rapid mineralization (Haggar et al. 1993; Mugendi et al. 2000) hence relatively lower N accounted for in the tithonia biomass compared to urea treatment. In this study, only the mineral N was determined as remaining in the soil however there was a possibility of some of the applied N being entrapped into the organic N pool. In their studies using *Calliandra calothyrsus* and *Leucaena leucocephala* in the humid highlands of Kenya, Mugendi et al. (2000) found out that close to 60% of N in the applied tree biomass was left in the soil N pool while about 25% could not be accounted for.

Conclusions

In this study, we were able to account for 92% of the urea-applied N and 62.2% of the tithonia-applied N. A greater percentage of the applied N both as tithonia and as urea was recovered by the maize crop. This accounted for 55.5% and 76% of the tithonia-applied N and urea-applied N respectively. Only 0.7% of the tithonia-applied N was leached down the soil profile and 9% from the urea-applied N while about 0.8% of the tithonia-applied N was observed in nitrous oxide emission and virtually no N loss observed in urea-applied plots through nitrous oxide emission. About 5.2%

of the tithonia-applied N was left in the top 0–10 cm soil layer while 7.8% was left in the urea-applied plots. We were not able to account for 37.8% and 8% of the tithonia-applied N and the urea-applied N respectively. More research is needed for long term evaluation on the effect of different nitrogen sources on N losses through N₂O emissions and leaching as well as N recovery by annual crops in the tropical farming systems.

Acknowledgements

The authors would like to thank the Rockefeller Foundation, which funded this research through the TSBF Institute. We would also like to thank the laboratory staff at the USDA-ARS in Fort Collins Colorado for helping in gas analysis. We are also grateful to all TSBF Nairobi staff led by Prof Mike Swift for their support throughout this study.

References

- Addiscott T.M. 1996. Fertilizers and nitrate leaching. In: Hester R.E. and Harrison R.M. (eds), *Agricultural Chemicals and the Environment. Issues in Environmental Science Technology*, Vol. 5, pp. 1–26.
- Anderson J.M. and Ingram J.S.L. 1993. *Tropical Soil Biology and Fertility: A Handbook of Methods*. CAB International, Wallingford, UK.
- Babbar L.I. and Zak D.R. 1996. Nitrogen losses from coffee agroecosystems in Costa Rica: leaching and denitrification in the presence and absence of shade trees. *J. Environ. Qual.* 24: 227–233.
- Brady N.C. and Weil R.R. 1999. *The Nature and Properties of Soils*, 12th ed. Prentice-Hall, Inc., New Jersey.
- Christianson C.B., Bationo A., Henao J. and Vlek P.L.G. 1990. Fate and efficiency of N fertilizers applied to millet in Niger. *Plant Soil* 125: 221–231.
- Di H.J. and Cameron K.C. 2002. Nitrate leaching in temperate agroecosystems: sources, factors and mitigating strategies. *Nutr. Cycl. Agroecosyt.* 46: 237–256.
- Dixon R.K. 1995. Agroforestry systems: sources or sinks of greenhouse gases? *Agroforest. Syst.* 31: 99–116.
- FAO (Food and Agriculture Organization) 1990. *New Environmental Threat: Declining Soil Fertility*. Land and Water Technical Newsletter.
- Gachengo C.N., Palm C.A., Jama B. and Otieno C. 1999. Tithonia and senna green manures and inorganic fertilizers as phosphorus sources for maize in Western Kenya. *Agroforest. Syst.* 44: 21–36.
- Giller K.E. and Cadisch G. 1995. Future benefits from biological nitrogen fixation: an ecological approach to agriculture. *Plant Soil* 174: 255–277.

- Glasener K.M. and Palm C.A. 1995. Ammonia volatilization from tropical legume mulches and green manures on unlimed and limed soils. *Plant Soil* 177: 33–41.
- Hagedorn F., Steiner K.G., Sekayange L. and Zech W. 1997. Effect of rainfall pattern on nitrogen mineralization and leaching in a green manure experiment in South Rwanda. *Plant Soil* 195: 365–375.
- Haggar J.P., Tanner E.V.J., Beer J.W. and Kass D.C.L. 1993. Nitrogen dynamics of tropical agroforestry and annual cropping systems. *Soil Biol. Biochem.* 25: 1363–1378.
- ICRAF 1995. Laboratory Methods for Soil and Plant Analysis: Version 1.1. Nairobi.
- Janzen H.H. and Schaalje G.B. 1992. Barley response to nitrogen and non-nutritional benefits of legume green manure. *Plant Soil* 142: 19–30.
- Jones R.B., Snapp S.S. and Phombeya H.S.K. 1997. Management of leguminous leaf residues to improve nutrient use efficiency in the sub-humid tropics. In: Cadisch G. and Giller K.E. (eds), *Driven by Nature: Plant Litter Quality and Decomposition*. CAB Int., Wallingford, England, pp. 239–250.
- Kimetu J.M. 2002. Nitrogen fertilizer equivalency values for organic materials of contrasting qualities based on maize performance at Kabete, Kenya. M.Env.S Thesis, Kenyatta University, Nairobi, Kenya, 74 p.
- Kimetu J.M., Mugendi D.N., Palm C.A., Mutuo P.K., Gachengo C.N., Bationo A., Nandwa S. and Kungu J.B. 2004. Nitrogen fertilizer equivalencies of organic materials of differing quality and optimum combination with inorganic nitrogen sources in Central Kenya. *Nutr. Cycl. Agroecosyst.* J. 68: 127–135.
- Kruijs A.C.B.M., van Wong M.T.F., Juo A.S.R. and Wild A. 1988. Recovery of ¹⁵N-labelled fertilizer in crops, drainage water and soil using monolith lysimeters in south-east Nigeria. *J. Soil Sci.* 39: 483–492.
- Kumar K.A., Menon P.K.G. and Sivakumar C. 1994. Effect of nitrogen management practices on ammonia volatilization losses in transplanted rice. *J. Trop. Agric.* 32: 54–59.
- Lehmann J., Feilner T., Gebauer G. and Zech W. 1999. Nitrogen uptake of sorghum (*Sorghum bicolor* L.) from tree mulch and mineral fertilizer under high leaching conditions estimated by nitrogen-15 enrichment. *Biol. Fertil. Soils* 30: 90–95.
- Loomis R.S. and Connor D.J. 1992. *Crop Ecology: Productivity and Management in Agricultural systems*. Cambridge University Press, Cambridge.
- Matson P.A. and Harriss R.C. (eds) 1995. *Biogenic Trace Gases: Measuring Emissions from soil and water*. Blackwell Science Ltd, Oxford OX2 OEL.
- Matson P.A., Naylor R. and Ortiz-Monasterio I. 1998. Integration of environmental, agronomic, and economic aspects of fertilizer management. *Science* 280: 112–114.
- Mugendi D.N. 1997. Tree Biomass decomposition, Nitrogen Dynamics and Maize growth under agroforestry conditions in the sub-humid highlands of Kenya. PhD Thesis, University of Florida, Gainesville, Florida, USA.
- Mugendi D.N., Nair P.K.R., Mugwe J.N., O'Neill M.K., Swift M.J. and Woomer P. 1999. Alley cropping of maize with Calliandra and Leucaena in the Sub-humid highlands of Kenya. Part 2: Biomass decomposition, N mineralization, and N uptake by Maize. *Agroforestry Syst.* 46: 51–64.
- Mugendi D.N., Nair P.K.R., Graetz D.A., Mugwe J.N. and O'Neill M.K. 2000. Nitrogen recovery by alley-cropped maize and trees from ¹⁵N-labeled tree biomass in the sub-humid highlands of Kenya. *Biol. Fertil. Soils* 31: 97–101.
- Palm C.A., Myers R.J.K. and Nandwa S.M. 1997. Combined use of organic and inorganic nutrient sources for soil fertility maintenance and replenishment. In: Buresh R.J. and Sanchez P.A. (eds), *Replenishing Soil Fertility in Africa* SSSA spec. Publ. 51. SSSA, Madison, WI.
- Paroda R.S., Woodhead T. and Singh R.B. (eds) 1994. *Sustainability of Rice–Wheat Production Systems in Asia*. Science Publishers, Lebanon.
- Patra A.K., Burford J.R. and Rego T.J. 1996. Volatilization losses of surface-applied urea nitrogen from Vertisols in the Indian semi-arid tropics. *Biol. Fertil. Soils* 22: 345–349.
- Peoples M.B., Freney J.R. and Mosier A.R. 1995. Minimizing gaseous losses of nitrogen. In: Bacon P.E. (ed.), *Nitrogen Fertilization in the Environment*. Marcel Dekker, Inc., New York.
- Puget P. and Drinkwater L.E. 2001. Short-term dynamics of root- and shoot-derived carbon from a leguminous green manure. *Soil Sci. Soc. Am. J.* 65: 771–779.
- Rees R. and Castle K. 2002. Nitrogen recovery in soils amended with organic manures combined with inorganic fertilizers. *Agronomie* 22: 739–746.
- Singh B.R. and Vaje P.I. 1998. Sustainable management of nitrogen in East Africa. *J. Sustain. Agric.* 13: 59–77.
- Spalding R.F. and Exner M.E. 1993. Occurrence of nitrate in ground water – a review. *J. Environ. Qual.* 22: 392–402.
- Terman G.L. 1979. Volatilization losses of nitrogen as ammonia from surface-applied fertilizers, organic amendments and crop residues. *Adv. Agron.* 41: 189–223.
- Westerman R.L., Kurtz L.T. and Hauck R.D. 1972. Division s-4 – soil fertility and plant nutrition: recovery of ¹⁵N-labeled fertilizers in field experiments. *Soil Sci. Soc. Am. Proc.* 36: 82–86.
- Xu Z.H., Saffigna P.G., Myers R.J.K. and Chapman A.L. 1993. Nitrogen cycling in leucaena (*Leucaena leucocephala*) alley cropping in semi-arid tropics: II. Response of maize growth to addition of nitrogen fertilizer and plant residues. *Plant Soil* 148: 73–82.

Integrated Soil Fertility Management Technologies: A Counteract to Existing Milestone in Obtaining Achievable Economical Crop Yields in Cultivated Lands of Poor Smallholder Farmers in Malawi

Moses Wazingwa Munthali

Chitedze Agricultural Research Station, P.O. Box 158, Lilongwe, Malawi, E-mail: munthalimw@yahoo.co.uk, nasc@malawi.net or agric-research@sdnp.org.mw

Abstract

Agriculture sector remains to be the engine of economic growth for Malawi as it contributes over 40% to gross domestic product of which over 70% is generated by the smallholder sector; 90% of export earnings, provides employment to over 85% of the country's population and income source for over 60% of the rural poor. Literature search has indicated that a lot of research work done on integrated soil fertility management and several technologies generated. Yet decline in soil productive capacity stemming from several types of soil degradation such as chemical (acidification, fertility decline/nutrient depletion) has been country's growing concern in limiting crop production. Most degraded soils in Malawi have low nutrient holding capacity, pH below 5.5, poor infiltration and moisture retention qualities with little organic matter and severe nutrients depletion. Sulphur for instance, is universally deficient whereas K has deficiency of about 20% in many parts of the Northern and Central Regions. Integrated soil fertility management technologies such as combined use of organic and inorganic fertilizers are vital in improving and sustaining crop production. However, most smallholder farmers have not opted for some of these technologies and consequently are experiencing poor and decreasing crop yields. Recently, several deficient nutrients not commonly known to farmers (Zinc, Calcium and Magnesium) besides nitrogen and phosphorus have been found to be limiting economic crop yields. Proper knowledge and enhanced use of integrated soil fertility management technologies are vital and likely to boost economic crop productivity in Malawi

Key words: Crop yields, Deficient elements, integrated soil fertility management, Smallholder farmers, Soil degradation

Introduction

Malawi is a land locked country extending from 9°45' to 17°5' South of the equator to about 900 km in length from North to South and varying in width from 80 to 160 km. Its population is estimated at about 11 million with an average growth rate of 3.3% per year (Saka et al., 2004). Malawi is endowed with many natural resources. Its main resource base is agriculture, which plays a key role in the country's economy.

The agriculture sector remains to be the engine of economic growth in Malawi as it contributes over 40% to gross domestic product (GDP) of which over 70% is generated by the smallholder sector; 90% of export earnings, provides employment to over 85% of the country's population and income source for over 60% of the rural poor (Kumwenda et al., 2003).

Soil is Malawi's valuable resource that plays a key role in agriculture. Most of the soils in Malawi are highly weathered, low in organic matter (OM) and deficient in the important nutrient elements. Continuous

cropping on the same land without replenishing the nutrients taken up by crops has led to a steady decline in soil fertility. This has resulted into declining yields of many crops contributing to food insecurity. Per capita cereal production, mainly maize, declined by 4% per annum between 1981 and 1990. It has been established that the infertile soils of Malawi are deficient in N, P, K, S, Zn and B (Mughogho, 1992; Kumwenda, 1995).

Existing milestones in crop production by smallholder farmers in Malawi

There are several factors such as soil degradation that are limiting crop productivity in Malawi. The most recent state of the Environmental report (MoFFEA 1998) ranks soil degradation as the most serious environmental problem facing modern Malawi. Evidence for declining soil productivity is provided by pronounced fall in unfertilized maize yields and parallel decline in the response of crops to fertilizer. In the past years, unfertilized local maize typically yielded 1,700 kg ha⁻¹, but now yields have fallen to a national average of less than 1,000 kg ha⁻¹, with performance lowest in the more densely populated Southern Region (yields had fallen as low as 600–800 kg ha⁻¹ in Chiradzulu and Phalombe Districts) (Douglas et al., 1999). Smale (1991) reported maize yields of 0.8 ton/ha from unfertilized local maize and 2.5 ton/ha from fertilized maize. Across the country, the maize response to fertilizer has declined, for example, in Lilongwe District it has fallen from an average of 23 kg (local) maize per kg of nitrogen to 13 kg per kg of nitrogen (Douglas et al., 1999).

Soil chemical degradation in Malawi

Soil chemical degradation such as fertility decline (nutrient depletion), acidification and aluminium toxicity is common in the country. Organic matter is generally low in most of the soils in Malawi. This is true in areas where there has been continuous cultivation of land for many years. In such areas, farmers have the tradition of burning crop residues instead of burying them into the soil. This combined with other factors has led into most of the soils in Malawi to be highly weathered, low in soil organic matter and nutrients such as N, P, K, S, Zn and Cu (Bationo et al., 1987). Maida and Chilima (1976) reported that a continuous cultivation

without inorganic fertilizer and organic manure application resulted in a marked decrease in total organic matter, nitrogen and exchangeable K, Mg and Ca. Soil degradation such as low and/or declining soil fertility are the most single factor responsible for reduced crop yields in the smallholder sector (Saka et al., 1995).

Nutrient depletion

Currently, most of Malawi's soils are severely depleted in nutrients, particularly N, and depending on location P, S, B and Zn. Soil fertility work on farmer's fields conducted jointly by the Ministry of Agriculture and Irrigation and FAO/UNDP, showed some deficiencies of S, Zn, K and Cu apart from P and N deficiencies. Ca and Mg deficiencies were also observed in some areas. A report on micronutrients by FAO (Sillanpaa, 1982) did find extensive B deficiencies in Malawi, particularly, in the Southern Malawi.

The MoA/FAO/UNDP study (Matabwa and Wendt, 1993) indicated that S was universally deficient at all the soil sampling sites. Zn deficiencies were localised in the southern part of Lilongwe Agricultural Development Division and all areas sampled in Mzuzu Agricultural Development Division (MZADD). K was mostly deficient in Kasungu Agricultural Development Division where soils are coarse textured, whereas many parts of the northern and central regions were 20% deficient in K. Cu deficiencies are mostly found in MZADD. Soil survey conducted by Chitedze Soils Laboratory Improvement Project has revealed that Zn and P are deficient apart from N and S deficiencies. K was not considered as a deficient nutrient element. However, K is also becoming a problem in some soils especially those that are continuously and intensively cultivated (Chilimba and Saka, 1998). Recently, S is becoming the most deficient nutrient element in most soils of Malawi and limiting crop production. The fertilizer containing 23%N, 21%P and 4%S was introduced in Malawi for maize production in recognition of S deficiency in Malawi soils. However, the amount of S in the recommended fertilizer does not provide adequate S for crop growth and yield (Chilimba et al., 2002). Recently, several deficient nutrients apart from N, P that have been found to be limiting economic crop yields, hitherto not known to farmers include K & S in addition to B, Zn, Ca & Mg (Saka et al., 2004).

The depletion is a consequence of continuous growing of crops on the same piece of land and in most cases without rotation or fallowing leading to severe nutrient

depletion. Also most farmers have the tendency of not burying crop residues into the soil and instead they burn them. Consequently, most of S and N are lost into the atmosphere. Mughogho (1992) reported that between 1/3 and 1/2 N remains in crop residues after harvest. Through burning, virtually all the N will be lost into the air. Douglas (1984) reported that an estimation of at least 17–20 kg of N, is lost due to burning of crop residues from 1 ha of improved maize field in Malawi.

Extent of low pH soils

Soil acidity is becoming common in most parts of Malawi and is limiting crop production. Continuous cultivation and burning of crop residues during land preparation has contributed to the problem. More acid soils occur in the high rainfall areas (>1000 mm per year) with moderate to high leaching, whereas, the alkaline soils occur in low rainfall areas (< 500 mm per year). The bulk of very acid soils are located in Lilongwe, Mzuzu and Blantyre ADDs. Areas of soil pH less than 5.5 have been identified in the country. Chilimba (1994) reported higher Al saturation percentage in Nkhatabay, Mulanje, Bembeke and Lunyangwa. The soils database prepared by the Soils Commodity Team has revealed that over 40% of the country has soil pH less than 5.5. The soil pH in Agricultural Development Divisions (ADDs) in the country is indicated in Table 1 below. The most known low pH soils are in Bembeke, Kanyama, Mayani in Dedza; Namwera Rural Development Project in Mangochi; Tsangano in Ntcheu; Mulanje RDP in Mulanje; Thyolo RDP in Thyolo; Nkhata Bay RDP; in Mzuzu ADD (Ntchenechena, Mphompha, uzumala, Mzuzu city, Mzimba central and South Mzimba) and Misuku Hills in Chitipa. High pH soils or alkaline/sodic soils are found in Shire Valley, along Lake Chilwa, Lake Malawi and in most dambos in the country (Chilimba and Komwa 2003).

In such soils, smallholder farmers who are growing their crops are experiencing very low crop yields and in some cases are harvesting nothing at all. For instance, Munthali and Chilimba (2004) reported that maize yields (Table 2) were reduced by over 85% in acid soils at Lunyangwa as compared to the potential yield of 8.5–10 ton ha⁻¹ under normal soil fertility conditions.

Reduced plant growth in acid soil is caused by increased solubility of soil Al and Mn, which cause toxicity. The soluble Al and Fe fix the available P in the soil, which induce P deficiency in crops. Low availability

Table 1. Percentage Area Covered by Soil pH Values below 5.5 in the Four ADDs.

Agricultural Development Division (ADD)	Soil pH Range	% Area Coverage of Soil pH
Blantyre	4.2–5.5	36
Kasungu	4.2–5.5	10
Lilongwe	4.7–5.5	65
Mzuzu	4.4–5.5	33

Source: Chilimba and Saka, 1998.

Table 2. Effects of fertilizer on maize yields in Acid Soils at Lunyangwa in Malawi.

Source of Fertilizer (92 kg N ha ⁻¹)	Maize grain yield (kg ha ⁻¹)
Inorganic	785.6
Organic (compost manure)	639.1
Control (no fertilizer applied)	356.4

Source: Modified from Munthali and Chilimba, 2004.

of micronutrients such as Zn and Mo is also enhanced. Kamprath (1970) reported that Al saturation more than 40% was detrimental for many agronomic crops. Liming is recommended that it should be done when the soil pH values are lower than 5.5 (Kamprath, 1970). Research conducted on liming in Malawi has shown that liming increased crop yields and that dolomite lime gave better crop yields than calcite in some sites (DAR, 1975 and Chilimba and Komwa, 2003).

Use of inorganic fertilizers by smallholder farmers

Malawi soils are becoming deficient in more than two nutrient elements. The Malawi Government policy encourages use of inorganic fertilizer. Use of chemical fertilizer has been advocated for many years to replace the depleted nutrients. Unfortunately the use of fertilizer is becoming impossible especially for smallholder farmers due to increase in prices. Most of smallholder farmers are poor and unable to buy inorganic fertilizers. Most of the current recommended basal dressing fertilizers only supply either N or P or both nutrient elements. For instance, Diammonium phosphate (DAP) only supplies 18%N and 46% P. Yet N, P, K, S nutrient elements are very critical at any stage of plant growth

and development. At the present, there are no basal dressing fertilizers that can supply all N, P, K and S nutrient elements to the soil. Most of Malawi farmers are not able to buy all the straight fertilizers in order to supply N.P.K. and S nutrients requirements for crop production. Hence such smallholder farmers are failing to use fertilizers in their crop production. The use of inorganic fertilizers has declined to almost 40% as they are very expensive and unaffordable by most smallholder farmers in Malawi (Kumwenda et al., 1997).

However, the ISFM technologies are promising and their usage is likely to reduce soil degradation problem and improve and maintain soil productivity for sustainable high crop production. ISFM technologies such as conservation tillage provide an opportunity for replenishment of organic matter and wide range of macro and micro-nutrients. There is a need to promote and enhance the usage of ISFM technologies.

Integrated Soil Fertility Management (ISFM) practices

Research work has been done on integrated soil fertility management and several technologies have since been developed. ISFM technologies through the combined use of organic and inorganic fertilizers are vital in the improvement, sustainable and high economical crop production of Malawi soils. Chilimba et al. (2004) evaluated the response of maize grain yield to applied compost and farmyard manure in combination with inorganic fertilizer materials at Bvumbwe and Chitedze (Table 3). Both organic and inorganic fertilizers increased maize grain yield over the control (without N application).

Integrated use of inorganic fertilizers and organic manure such as compost, green and farmyard is in many ways advantageous as soil organic matter is replenished and builds the nutrient reserve in the soil. Organic manure releases nutrients slowly, reducing the risk of leaching and improves soil water retention (Parr, 1986) and microbial activities that greatly contribute to nutrient recycling in different cropping system. Organic manure helps to supply even micronutrients which may not be supplied in commercial fertilizers (Mughogho, 1992). The application of organic manure such as compost to soil is the quickest and most effective way of raising the organic matter levels for the soil fertility improvement (Douglas, 1984). Organic manure

Table 3. Effect of organic, inorganic and combinations of organic and inorganic fertilizers on maize yield (tons ha⁻¹). In all the treatments 92 kg N ha⁻¹ was applied.

N source	Bvumbwe	Chitedze
No fertilizer (0 kg N ha ⁻¹)	2.3	4.5
Inorganic N fertilizer	5.1	6.5
Sole Compost	3.0	6.9
¹ / ₄ Compost+ ³ / ₄ Inorganic	4.5	7.5
¹ / ₂ Compost + ¹ / ₂ Inorganic	3.8	7.5
³ / ₄ Compost + ¹ / ₄ Inorganic	2.9	7.2
¹ / ₃ Compost + ² / ₃ Inorganic	3.7	6.8
² / ₃ Compost + ¹ / ₃ Inorganic	4.0	7.3
Sole Farmyard manure	3.0	7.4
¹ / ₄ Farmyard manure+ ³ / ₄ Inorganic	3.9	6.5
¹ / ₂ Farmyard manure+ ¹ / ₂ Inorganic	3.3	6.5
³ / ₄ Farmyard manure+ ¹ / ₄ Inorganic	3.6	6.7
¹ / ₃ Farmyard manure+ ² / ₃ Inorganic	4.2	6.1
² / ₃ Farmyard manure+ ¹ / ₃ Inorganic	2.9	6.8
LSD (0.5)	1.44	2.41
CV (%)	24	21

Source: Chilimba et al., 2004.

improves rain water infiltration, water holding capacity, raise soil pH in acid soils and increases fertilizer use efficiency. Mwandemere (1985) reported that the use of nitrogenous fertilizer may be cut down to about 50% due to increased fertilizer use efficiency. Kumwenda et al., 1997 got similar results (Table 4) through legume incorporation.

Sakala et al. (2001) also reported that a combination of organic (green manure) and inorganic fertilizer (Table 5) increased fertilizer use efficiency at both rates of inorganic fertilizer (35 and 69 kg N ha⁻¹) that were applied together with the green manures that were incorporated during the first season compared to where inorganic fertilizers were applied alone. Although fertilizer use efficiency was increased by combining organic and inorganic fertilizer, the fertilizer use efficiency was much higher when lower rates of 35 kg N ha⁻¹ were applied.

However, most smallholder farmers have not opted for some of these technologies and consequently are experiencing poor and decreasing crop yields. The use of ISFM technologies such as conservation tillage, organic manure and agroforestry is very low in Malawi. There was a case study conducted in relation to adoption of soil fertility improving technologies in Lilongwe District by Munthali (2003). It was found that the number of farmers practicing soil improvement technologies was small implying a low rate of

Table 4. Maize grain yield (kg ha⁻¹) response to legume residues and inorganic fertilizer, Chitedze Research Station.

Cropping System	Type of Crop Residue	0 kg N ha ⁻¹	48 kg N ha ⁻¹	96 kg N ha ⁻¹	Mean
Maize–Maize	None	3547	5167	5267	4669
Maize/Pigeonpea Intercrop	Pigeonpea	3698	5108	5415	4739
Maize/Sun hemp	Sun hemp	4635	5233	5324	5064
Maize/Mucuna	Mucuna	3599	3972	4745	4101
Maize after Pigeonpea	Pigeonpea	5729	6073	6104	5968
Maize after Sun hemp	Sun hemp	5477	6121	6516	6038
Maize after Mucuna	Mucuna	4484	5357	6598	5813
Mean		4451	5433	5714	5199

SE (±): cropping system: 296; Nitrogen rates: 123; cropping systems x N rates: 326ns.

Source: Kumwenda et al., 1998.

Table 5. Effect of three different rates of inorganic fertilizer application following legumes or sole maize on maize grain yield across six sites for two seasons.

Legume Incorporation Time	0 (kg N ha ⁻¹)	35:10:0+2S (kg N ha ⁻¹)	69:21:0+4S (kg N ha ⁻¹)	Mean
Mucuna early	2057	2633	3480	2723
Mucuna late	2157	2672	3514	2781
Crotalaria early	2239	3149	3684	3024
Crotalaria late	1829	2864	3600	2764
Lablab early	2014	2807	3363	2728
Lablab late	1708	2875	3390	2657
Maize	1240	2223	2718	2060
Mean	1892	2746	3393	2677
	Legume	Fertilizer	Interaction	
Significant level	0.001	0.001	NS	
SED	94	71	204	
CV%	6	9	9	

Source: Sakala et al., 2001.

adoption. The adoption rate was 23.4%. Most of them continuously grow their crops on the same piece of land through usage of inorganic fertilizers only as they burn crop residues. The integrated use of organic and inorganic fertilizers is critical, very vital and necessary in the management of soil for improved and high sustainable soil and crop productivity.

Conclusion

The challenge facing Malawi to day is to produce more food under smallholder farmers' constraints of limited cash, labor and poor soil fertility management. If the current trend of soil degradation continues, then crop production will continue to decline as a result majority of smallholder farmers in Malawi will continue to have the problem of food insecurity. The government's vision on food security and poverty alleviation will not become a reality. Literature indicates that research

work has been done on integrated soil fertility management and several technologies have been generated. However, it has been shown that most of the farmers are not putting such technologies into practice. ISFM technologies are promising and their usage is likely to reduce soil degradation problem and improve and maintain soil productivity for sustainable high crop production. This requires the implementation of highly effective and well coordinated ISFM practices that increases fertilizer use and fertilizer use-efficiency. Proper knowledge and enhanced use of ISFM technologies are vital, necessary and likely to boost economic crop productivity in Malawi.

References

- Bationo A., Christianson C.B and Mokwunye U. 1987. Soil Fertility Management of the Pearl Millet – Producing sandy soils of Sahelian West Africa: The Niger experience. In: Management Systems for rainfed agriculture in the Sudano Sahelian Zone, pp. 165–166.

- Chilimba A.D.C. 1994. Annual Report: Soil Fertility and Plant Nutrition Commodity Team, Department of Agricultural Research Services, Ministry of Agriculture, Lilongwe, Malawi.
- Chilimba A.D.C., Chigwenembe S., Lungu B.W. and Sonjera P.A. 2004. The effects of different organic fertilizers and their interactions with inorganic fertilizer on maize yield. In: Annual report of the Soils Fertility and Plant Nutrition Commodity Team, Ministry of Agriculture, Lilongwe, Malawi.
- Chilimba A.D.C. and Komwa M.M. 2003. Soil fertility Status in Lilongwe Agricultural Development Division. A Final Report. Chitedze Agricultural Research Station, Lilongwe, Malawi.
- Chilimba A.D.C. and Saka A.R. 1998. Soil Degradation: An overview of the management and rehabilitation in Malawi. A first update of the paper presented at An Expert Consultation Meeting of the Network on Management of degraded Soils in Southern and Eastern Africa held at Zimbabwe from 7–12 December, 1998.
- Chilimba A.D.C., Sakala W.D. and Kabambe V.H. 2002. Sulphur deficiency for Maize in LADD. Network research results Working Paper No. 11 Nov 2002. CIMMYT.
- Douglas M.G. 1984. Integrated Land Use: An appropriate approach to soil conservation for smallholder farmers. Annual Report, Ministry of Agriculture LADD, Malawi.
- DAR 1975. Annual Report of the Department of Agricultural Research, Lilongwe, Malawi. Govt. Press.
- Douglas M.G. 1984. Integrated land use: An appropriate approach to soil conservation for smallholder farmers. Annual report, LADD, Lilongwe, Malawi.
- Douglas M.G., Mughogho S.K and Saka A.R. 1999. Malawi: An investigation into the presence of a cultivation hoe pan under smallholder farming conditions. TCI Occasional Paper Series No. 10, November 1999.
- Kamprath E.J. 1970. Exchangeable aluminium as a criterion for liming leached mineral soils. *Soil Sci. Soc. Amer. Proc.* 34:252–254.
- Kumwenda M.S.L. 1995. Mineral Status in Soils and Forages in Mzuzu Milkshed Area. Annual Report, Lunyangwa Agriculture Research Station, Mzuzu, Malawi.
- Kumwenda J.D.T., Waddington S.R., Snapp S.S., Jones R.B. and Blackie M.J. 1997. Soil fertility management in the smallholder maize-based cropping systems of Africa. In: *The emerging maize revolution in Africa: The role of technology, institution and policy.* Michigan State University, USA, 9–12 July, 1995.
- Kumwenda J.D.T., Saka A.R., Snapp S.S., Ganunga R.P. and Benson T. 1997. Effects of organic legume residues and inorganic fertilizer nitrogen on maize yield in Malawi. In: *Soil Fertility research for maize-based farming systems in Malawi and Zimbabwe.* Waddington S.R., Murwira H.K., Kumwenda J.D.T. & Hikwa D. (eds.). CIMMYT, Mutare.
- Maida J.H.A. and Chilima Z.W. 1976. Changes in Soil Fertility under continuous cropping of Tea: Technical Bulletin No. 1/Bv/76. Bvumbwe Research Station, Limbe, Malawi.
- Matabwa C.J. and Wendt J.W. 1993. Soil Fertility management: present knowledge and prospects. In Munthali D.C., Kumwenda J.D.T. and Kisyombe F. (eds). *Proceedings, conference on Agricultural Reserach for Development.* 7–11 June 1993, Department of Agricultural Research Services, Ministry of Agriculture, Lilongwe, Malawi.
- MoFFEA 1998. State of environment Report for Malawi 1998. Environmental Affairs Department of the Ministry of Forestry, Fisheries and Environmental Affairs, Lilongwe, Malawi. Govt. Press.
- Mughogho S.K. 1992. Soil Fertility Research in Malawi: A Review. University of Malawi, Bunda College of Agriculture, Lilongwe, Malawi.
- Munthali M.W. 2003. Factors affecting household decision making in adoption of soil improvement agroforestry technologies: A case study of villages around Bunda College in Lilongwe District. B.Sc. Thesis. University of Malawi, Bunda College of Agriculture, Lilongwe, Malawi.
- Munthali M.W. and Chilimba A.D.C. 2004. Effects of composting materials and methods of composting on quality of compost and maize yields. In: 2004 Annual Report of Soils and Agricultural Engineering Commodity Group, Ministry of Agriculture, Chitedze Research Station, Lilongwe, Malawi. pp. 52.
- Mwandemere H.K. 1985. Integrated Nutrient Supply: Filter press mud (FPM), Farmyard manure (FYM) and Ash as sources of P and N. Project 33 soils. In: *DARS Annual Report, Chitedze Research Station, Lilongwe, Malawi.*
- Parr J.F. 1986. Recycling of organic wastes for sustainable agriculture in soil management in sustainable agriculture: In: *Proceedings of the 3rd International Conference on sustainable agriculture.* Wye College, University of London, pp. 123.
- Saka A.R., Green R.I. and Ng'ong'ola D.H. 1995. Proposed soil management action plan for Malawi. A report for soil management in sub-Saharan Africa. World bank, Washington.
- Saka A.R., Phiri I.G.M., Munthali M.W. and Makumba W. 2004. Process and Adaptive Research conducted on integrated soil fertility management in Malawi. Department of Agricultural Research Services, Ministry of Agriculture, Lilongwe, Malawi.
- Sakala W.D., Kumwenda J.D.T., Saka A.R. and Kabambe V.H. 2001. The potential of legume green manures to increase soil fertility and maize yields under smallholder farm conditions in Malawi. In: Phiri I.M.G., Saka A.R. and Chilimbwe E.H.C. 2001. *Agricultural Technologies for sustainable development in Malawi.* DARS Annual Scientific Proceedings No. 1. Department of Agricultural Research Services, Lilongwe, Malawi, pp. 34–40.
- Sillanpaa M., 1982. Micronutrient and nutrient status of soils. A global study. *FAO Soil Bull.* No.48, Rome, pp. 363–371.
- Smale M. 1991. Chimanga Chamakono, Hybrids and Composites: An Analysis of Farmers' Adoption of Maize Technology in Malawi. *CYMMYT, Lilongwe, Malawi,* pp. 17–23.

Fertilizer nitrogen recovery as affected by soil organic matter status in two sites in Kenya

Karunditu M.W.^{1*}, Mugendi D.N.¹, Kung'u J.¹ and Vanlauwe B.²

¹Kenyatta University, P.O Box 43844, Nairobi, Kenya; ²Tropical Soil Biology and Fertility, P.O Box 30677, Nairobi, Kenya; *Author for correspondence: Tel: +254 20 7224753/9, Mobile: +254 20 0733260295 Email: karunditum@yahoo.co.uk

Abstract

Management of nitrogen (N) nutrition is a vital aspect in maize production systems of Kenya. In Central and Western parts of Kenya, high population density has eliminated the use of traditional fallow farming systems for replenishing soil fertility while high unevenly distributed rainfall increase chances of N leaching. A study was conducted at Maseno, and Kabete to investigate the fate of fertilizer N in the soil-plant system using treatments that had been receiving leaf prunings of *Calliandra calothyrsus* and *Tithonia diversifolia*. Two microplots were installed in the main treatments to which labelled fertilizer was applied. At the beginning and at the end of 2002 long rains, soil was sampled to 200 cm for N and ¹⁵N enrichment analysis at the two trials. Also at the end of the season plant samples were collected for N and ¹⁵N analysis. At Maseno trial, evenly distributed rainfall and the influence of organic resource quality enhanced good fertilizer nitrogen recovery in the maize crop. Also substantial nitrate movement down the soil profile was observed in the control followed closely by calliandra at the end of the 2002 long rains season. At Kabete trial recorded the poorest fertilizer N recovery due to unevenly distributed rainfall. Limited soil moisture reduced both soil and fertilizer N uptake which was reflected in high N in the top soil and low recovery in plant. Most of the nitrate-N was left in the top soil as a result of low rainfall which couldn't move it into the lower soil depths

Key words: Labelled fertilizer, mineral N, nitrate movement, microplots, nitrogen-15

Introduction

Effective management of nitrogen (N) presents a greater challenge to the farm operator than any other nutrient since it can enter or leave the soil-plant system by more routes than any other nutrient (Olson and Kurtz 1982). Nitrogen is the key to soil fertility and an essential component of soil organic matter (SOM), in fact, 90-95% of the total soil nitrogen (N) is associated or combined with the soil organic fraction (Andreux et al. 1990; Smith 1994). Therefore maintenance of an adequate soil nitrogen level goes hand in hand with maintenance of an adequate level of humus, which in turn determines many other factors related to

soil fertility (Kang and Van der Heide 1985; National Research Council 1993).

Organic matter plays key roles in nutrient retention and availability, soil structure maintenance and water retention since it constitutes both a sink and a source of nutrients required by plants and ultimately by the human population (Craswell and Lefroy 2001; Merckx et al. 2001). Increasing the SOM content of soil is the key to building soil N capital (Buresh and Giller 1998). Nitrogen is the mineral element required in the greatest quantity by cereal crop plants and loss from a cropping system is a major source of agri-environmental pollution. Thus, N uptake and use by a maize crop is of fundamental importance to N economy in agricultural

production (Ma and Dwyer 1998). The mineral-N may be unavailable to the crop if moved below the crop(s) rooting depth by percolating water (Mugendi et al. 1999b).

Nitrogen fertilizer use efficiency (NFUE) is important due to environmental consequences of nitrate leaching (a global phenomenon) whose impact is recent in developing countries (de Vos et al. 2000; Rao and Rattanna 2000). It is therefore important to know to what extent nitrogen is recovered by the crop and whether nitrogen is left in the soil (Dilz 1988). Of importance to crops as shown by Mafongoya and Nair (1997) is accumulation of available N in the soil before the peak period of N uptake by maize which ensures synchrony between N supply and demand by the maize crop. Efficiency of N could be improved by 10-20% mostly due to an increase of about 16% in plant uptake of N (Isherwood 2000). On the other hand, organic resources play a critical role in both short-term nutrient availability and long-term maintenance of SOM in smallholder farming systems in the tropics (Palm et al. 2001).

To determine the movement of fertilizer N as affected by SOM status it is necessary to use ^{15}N -labelled fertilizer so as to distinguish between soil and fertilizer derived N (Bacon 1995; Hood 2001). Continued decline of soil fertility against the background of increasing rural poverty is threatening the smallholder farmer's long term food security and their source of livelihood. There is no doubt that the need to reverse decline in soil fertility is becoming critical. The challenge today is to find sustainable ways to increase agricultural growth at a rate faster than human population growth (Kamanga et al. 2000). This study therefore sought to determine (i) fertilizer N recovery in both plant components and top soil (ii) mineral N in the soil profile as affected by SOM status at three trials in Kenya.

Materials and methods

The study was conducted in two trials in Cental and Western Kenya. The Nitrogen Management (N1) at Kabete in Central Kenya is located at a longitude of $36^{\circ} 46' \text{E}$, latitude of $01^{\circ} 15' \text{S}$ and an altitude of 1650 m above sea level. The site is located in the semi-humid climatic zone with a total bimodal rainfall of about 970 mm per annum received in two distinct rainy seasons; the long rains received mid March to June and the short rains received mid October to December. The soils

are quartz trachyte geological material, and are typical Humic Nitisols, inherently fertile, with moderate amounts of C, Ca, Mg, and K but low in available P. Phosphorus management (PM1) experiment is located in the highlands of Western Kenya, on Msinde farm in Vihiga District. The experiment was established during the short rains of 1995 as Randomized complete Block Design (RCBD) with four replicates. The site is located at an altitude of 1420 m above sea level, latitude of $0^{\circ} 06' \text{N}$ and a longitude of $34^{\circ} 34' \text{E}$. The mean annual rainfall is 1800 mm distributed in two distinct rainy seasons: long rains from March to August and short rains from September to January. The soil is a Nitisol according to FAO (1990) with 42% clay, 25% silt and 33% sand (Nziguheba 2001).

The ^{15}N experimental layout was a randomized complete block design (RCBD) with three replicates and maize (HB613) as the test crop. Two microplots measuring 3 by 1.25 m were established in each selected main plot. They were surrounded by 25 cm tall metal borders measuring 0.25×1.8 m which were inserted 15 cm into the soil with 10 cm remaining above the soil surface to prevent lateral movement of materials. Labelled ammonium sulphate (AS) was applied in microplots installed at planting and at knee height. The recovery of applied ^{15}N in the crop and soil was determined at the end of the cropping season. Maize was planted at an intrarow and interrow spacing of 0.25 and 0.75 m respectively.

Soil samples were sampled at planting and harvest from six depths (0-10, 10-30, 30-60, 60-100, 100-150 and 150-200 cm) for moisture determination, N, and ^{15}N enrichment determination. Plant samples (ears and stover) were separated from a sampling area of 1.125 m^2 net plot of each microplot. Sub samples of six plants were chopped, their fresh weights taken, then oven dried at 60°C until weights stabilized, ground to pass through a 1 mm sieve. The harvested maize ears were also oven dried, shelled and cob and grain weighed separately.

A sub sample (1-6 mg) (pulverized stover, grain and cob) was weighed into tin capsules which were then analysed for total N and ^{15}N enrichment with an Automated Nitrogen and Carbon Analyzer–Mass Spectrometer (ANCA-MS). Total N and ^{15}N values obtained were later used in the determination of %N derived from fertilizer and % fertilizer N in the plant samples.

For determination of ammonium and nitrate, about 20 g of field moist soil was extracted with 100 ml of 2N KCl by shaking for 1 hour at 150 reciprocation per minute and subsequent gravity filtering with prewashed

Whatman No 5 paper. Soil water content was determined on stored field-moist soil at the time of extraction in order to calculate the dry weight of extracted soil. The extract was then analysed for extractable nitrate by Cadmium (Cd) reduction column and for extractable ammonium by salicylate-hypochlorite colorimetric method (Anderson and Ingram, 1993 and ICRAF, 1995). Soil water content was determined on the field moist soils at the time of extraction in order to calculate the dry weight of extracted soil. About 25-35 g of the soil sample was oven dried at 105°C for 24 hours after which sample dry weight was taken. The moisture content obtained was used in the calculation of mineral N (ammonium-N and nitrate-N) content in the soil that had been extracted with 100 ml 2N KCl as shown in the nitrate and ammonium formulae (Anderson and Ingram 1993; ICRAF 1995).

Statistical analysis

Data was analysed using GenStat for windows software (version 6.1, Rothamsted Experimental Station) (GenStat 2002). It was subjected to analysis of variance (ANOVA) for both within site and between sites variations. Treatment means found to be significantly

different from each were separated by Least Significant Differences (LSD) and declared significant at P = 0.05 (Fisher, 1935). This was to determine relationships between SOM content and the movement of the applied fertilizer N in terms of crop uptake use efficiency and in relation to N application.

Results

Fertilizer nitrogen recovery in both plant and soil as affected by SOM status

At the end of the cropping season fertilizer N used by the crop and remaining in the soil organic forms was measured. Fertilizer N recovered in maize plant components (maize grain, cob and stover) and in soil profile (0-30 cm) at PM1 and N1 trials is presented in Table 1 and 2 respectively. At PM1 trial (Table 1), Maize grains had more ¹⁵N compared to cob and stover in the L microplots. However, the ¹⁵N for maize grain and cob was statistically insignificant (P< 0.05). In the UL microplots, grain had higher allocation of fertilizer N and in descending order the ¹⁵N for maize grain was 27.4 > 26.7 > 17.3% for tithonia, calliandra and control treatments respectively whereby calliandra and

Table 1. Fertilizer ¹⁵N recovery at PM1-Maseno trial, Kenya at the end of 2002 long rains

Variable	Labelled first (L)				Labelled second (UL)			
	Calliandra	Tithonia	Control	Sed	Calliandra	Tithonia	Control	Sed
% fertilizer ¹⁵ N								
Grain	24.4	20.3	20.6	2.6	26.7	27.4	17.3	3.3
Cob	2.7	2.5	3.0	0.4	2.4	2.4	3.1	0.5
Stover	11.6	6.7	6.3	2.2	13.6	13.4	8.2	3.6
0-10 cm	22.7	17.6	20.8	1.5	24.0	21.0	21.3	2.9
10-20 cm	5.3	4.7	7.8	1.4	3.5	5.8	7.7	1.0
20-30 cm	3.9	3.1	5.7	1.4	3.4	3.1	3.9	0.6

Table 2. Fertilizer ¹⁵N recovery at NI-Kabete trial at the end of 2002 long rains

Variable	Labelled first (L)				Labelled second (UL)			
	Calliandra	Tithonia	Control	Sed	Calliandra	Tithonia	Control	Sed
% fertilizer ¹⁵ N								
Grain	3.8	6.7	2.4	2.3	0.5	0.5	1.2	0.5
Cob	0.5	1.2	0.7	0.4	0.0	0.1	0.1	0.1
Stover	20.8	19.5	22.7	7.1	3.1	2.0	1.9	1.4
0-10 cm	20.0	18.0	22.7	nd	91.5	93.1	94.6	8.0
10-20 cm	8.7	4.6	7.0	2.1	9.7	9.4	9.7	2.9
20-30 cm	4.5	3.0	3.6	1.0	3.1	1.2	4.2	1.6

tithonia treatments were significantly higher than the control. There was no significant difference in ^{15}N for cob and stover between the treatments.

Results from PM1 trial indicated that the amount of percent fertilizer in the 0-10 cm soil depth of the L microplots, was in the order of calliandra > control > tithonia, whereby in both depths calliandra treatment and control were significantly higher than tithonia treatment (Table 1). In 10-20 cm soil depth the order of percent fertilizer N was control > calliandra > tithonia whereby the control (7.8%) was significantly higher than tithonia treatment (4.7%). In 20-30 cm soil depths, percent fertilizer N was not significantly different between treatments.

At N1 trial (Table 2), in the L microplots recovery of % fertilizer ^{15}N in the maize components (maize grain, cob and stover) and in the various soil depths (0-30 cm)

was not significantly different among the treatments (calliandra, tithonia and control). The same trend was observed in the UL microplots except the recovery of fertilizer N in soil 0-10 cm soil depth where control was significantly different from calliandra treatment. This is because there was a dry spell in this trial and a lot of fertilizer N was left in 0-10 cm soil depth especially in the UL microplots.

Inorganic nitrogen in the soil profile

Mineral N dynamics in the soil profile as affected by SOM status at the PM1 and N1 trials are presented in Figures 1 and 4 respectively. They present a comparison between mineral N in the soil profile at the beginning of the season (day zero) and at the end of the season

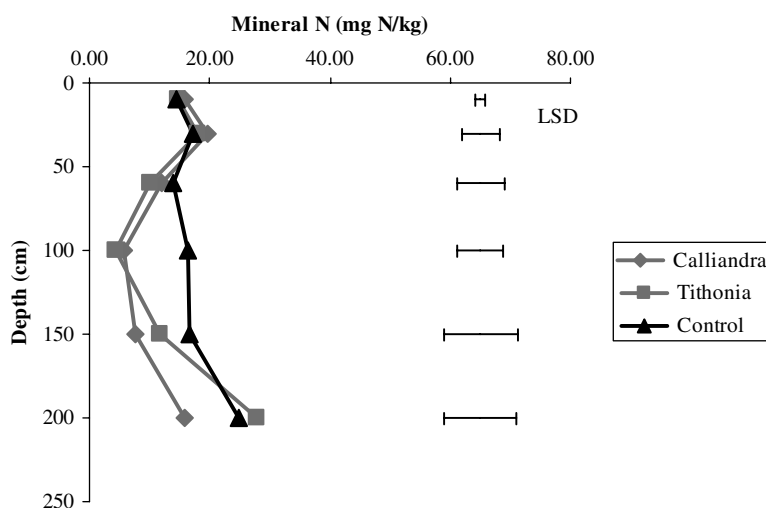

Figure 1. Mineral N status in the soil profile at the beginning of ^{15}N experiment at PM1-Maseno trial, Kenya.

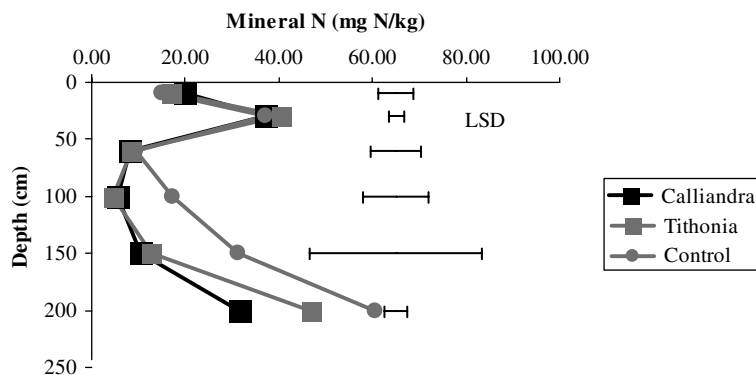

Figure 2. Mineral N in the soil profile at the end of 2002 long rains at PM1-Maseno trial, Kenya.

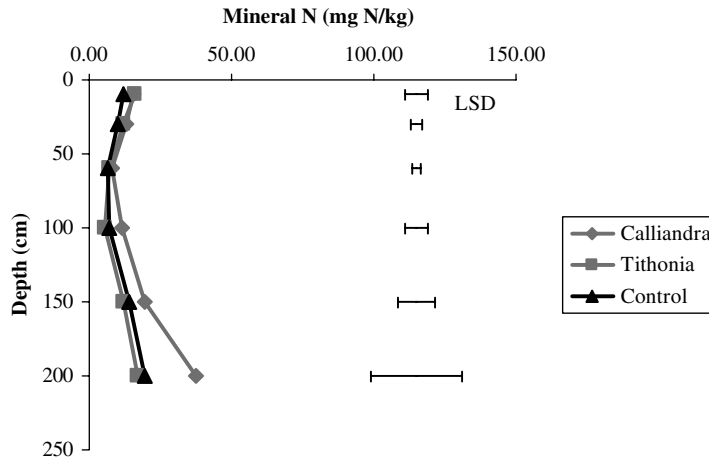

Figure 3. Mineral N status in the soil profile at the beginning of ¹⁵N experiment at N1-Kabete trial, Kenya.

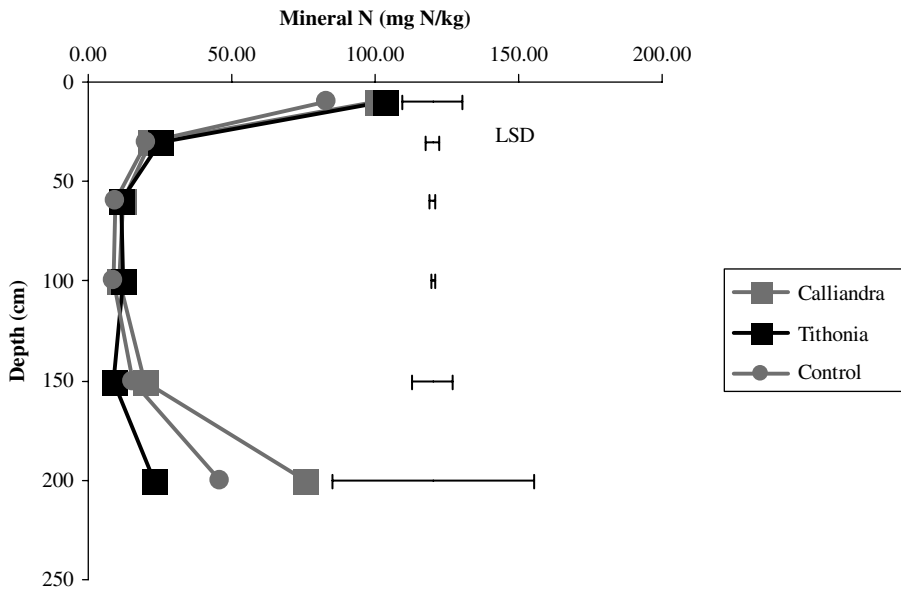

Figure 4. Mineral N in the soil profile at the end of 2002 long rains at N1-Kabete trial, Kenya.

(at harvest) which gives a picture of the extent of N movement down the soil profile at the two sampling times within a trial.

Results from PM1 trial (beginning of 2002 long rains) indicated no significant difference in the mineral N in soil depths 0-10, 10-30, 30-60, 100-150 and 150-200 cm (Figure 1). However, mineral N was significantly different for 60-100 cm soil depth with calliandra, tithonia and control recorded mineral N of 6, 4 and 16 mg N Kg⁻¹ respectively. In this depth, amount of mineral N in control was significantly different from those in calliandra and tithonia treatments.

Amount of mineral N in the soil profile at the end of 2002 long rains at PM1 trial (Figure 2) in 0-10 cm soil depth was not significantly different between the treatments. In 10-30 cm soil depth, the amount of mineral N was in the order of tithonia > control > calliandra whereby tithonia treatment had 40 mg N kg⁻¹ while calliandra and control each had 37 mg N Kg⁻¹. Again, amount of mineral N in the 10-30, 30-60, 60-100 and 100-150 cm soil depths was not significantly different between the treatments. In 150-200 cm soil depth; the order was control > tithonia > calliandra whereby control (61 mg N Kg⁻¹) had significantly higher mineral

N than calliandra (32 mg N Kg⁻¹) and tithonia (47 mg N Kg⁻¹) treatments. Also tithonia treatment had significantly higher mineral N than calliandra treatment.

There was no significant difference in mineral N movement down the soil profile in N1 trial (Figure 3) despite its concentration in the top soil. Results from N1 trial (Figure 4), indicated that in 0-10 cm soil depth amount of mineral N was not significantly different among treatments. In the 10-30 cm soil depth, the amount of mineral N was in the order of tithonia > calliandra > control, whereby tithonia treatment (25 mg N Kg⁻¹) was significantly higher than the control (20 mg N Kg⁻¹). In 30-60 cm soil depth the order was calliandra > tithonia > control whereby calliandra (12 mg N kg⁻¹), tithonia (11 mg N Kg⁻¹) and control (9 mg N kg⁻¹) and were not significantly different. In 60-100 cm soil depth amount of mineral N was in the order of tithonia > calliandra > control whereby calliandra (11 mg N Kg⁻¹) and tithonia (12 mg N Kg⁻¹) treatments were significantly higher than the control (9 mg N Kg⁻¹). Also, results indicated that in 100-150 and 150-200 cm soil depths amounts of mineral N was not significantly different among treatments.

Discussion

At PM1 trial the ability of calliandra to build SOM could explain why this treatment had significantly higher ¹⁵N recovery in the first fertilizer application. Hagggar et al. (1993) reported that the build up of SOM reserve of mineralizable N is very important because it is from this reserve that N is made available to the crop. Also the high N accumulation in maize was probably due to rapid assimilation of nutrients by maize plants. Chirwa et al. (2004) observed high N accumulation in

maize with fertilizer due to rapid assimilation. Higher enrichment on the other hand of ¹⁵N in plants occurs when the applied labelled fertilizer N becomes effectively incorporated into soil organic matter (Cadisch et al., 1993). At this trial availability of water may have increased nitrogen mineralization in the soil thus increasing available N supply and uptake which was reflected in good fertilizer N recovery. These results tally with what was observed by Kamoni et al. (2003) with fertilizer application under irrigated conditions.

The poor recovery in the second application of the labelled fertilizer at the N1 trial in the maize crop components could be attributed to poorly distributed rainfall (Figure 5) which confirms what Kamoni et al. (2003) observed. Insufficient rainfall reduced crop N uptake and as a result most of fertilizer N was left in the top soil as was also observed by Hubbard and Jordan (1996) and in their study where sum totals of soil recoveries ranged from 33.62 - 79.14%. The ¹⁵N concentration of plant components varied coinciding with findings by Ledgard et al. (1992). Since nitrogen transformations are intense in the root zone of crops under a broad range of conditions as noted by Atwell et al. (2002), inadequate water could have minimized these transformations leading to limited response of crops to fertilizer N and consequent low recoveries (Jama et al., 1995). The maize N recovery from applied N fertilizers was low (10-22%) (Okogun et al. 2000).

Ability of calliandra to build SOM in the soil could explain the high percent fertilizer N observed in 0-10 soil depth in calliandra treatment in the L microplots at PM1 trial. At 10-20 and 20-30 cm soil depths, a higher amount of fertilizer N was observed in the control. In the UL microplots, 10-20 cm soil depth control and tithonia had higher percent fertilizer N than calliandra treatment. Addition of labelled fertilizer N which was

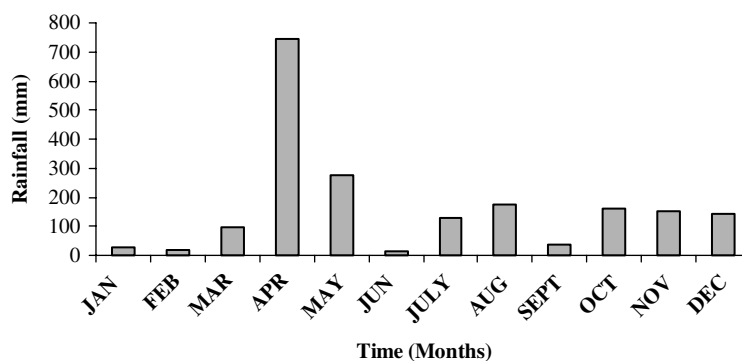

Figure 5. Rainfall at N1-Kabete trial in 2002 long rains.

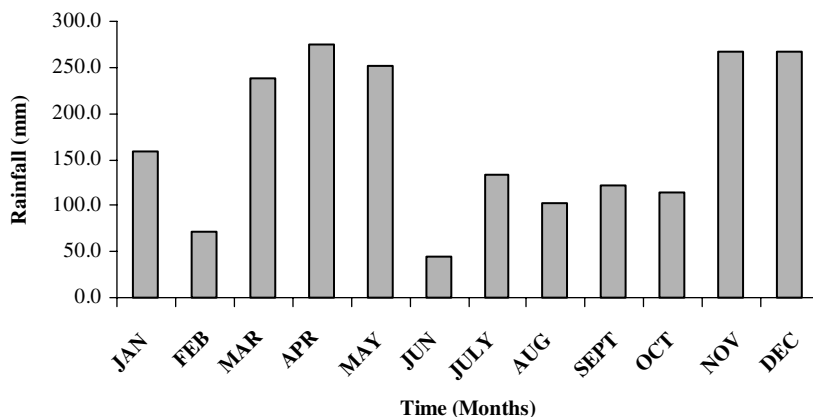

Figure 6. Rainfall at PM1-Maseno trial in 2002 long rains.

done even in the control explains why it had higher percent fertilizer N than the other treatments. On the other hand observations made at N1 trial in the L microplots, indicated that in the UL microplots, the 0-10 cm soil had percent fertilizer N ranging from 91.5 to 94.6%. Inadequate rainfall in this trial could have contributed significantly to poor crop uptake which was also observed by Kamoni et al. (2003) and as a result most of fertilizer N was left in the top soil. Inorganic fertilizer N is often readily immobilized into the organic pool of the soil such that a large proportion of fertilizer-N remaining in the soil at harvest was found in the plough layer. Water stress equally reduced the efficiency of N uptake.

Nitrate accumulation in the subsoil (30-200 cm) at PM1 trial concurs with the results found by Kindu et al. (1997); Mugendi et al. (2001) at 30-150 cm soil depth in a maize cropping system. Subsoil N accumulation could be attributed to greater N mineralization at the onset of the rainy season as well as high rainfall (Figure 6) that resulted in the subsequent nitrate movement down the soil profile. To avoid N loss through leaching Stenger et al. (1998) proposed that the inorganic N should be depleted during crop growth. The evidence of higher N movement in the control at this trial shows the importance of addition of organic residues and their SOM status improvement which is capable of minimizing N loss through leaching and enhancement of uptake and use efficiency of added fertilizer N. There was higher leaching in tithonia than in calliandra due to the differences in their resource quality (Xu et al., 1993). Poor resource quality residues (calliandra) are capable of building SOM as noted by Mafongoya and Nair (1993) and

Mugendi et al. (2000) which is capable of minimizing N leaching.

Despite the concentration of mineral N at 0-10 cm soil layer at N1 trial, substantial N movement beyond the crop rooting depth occurred in both calliandra and control which could be attributed to the high rainfall intensity at the beginning of the experiment before the crop established a rooting system. Kimetu (2002) in his study carried out at N1-Kabete also found mineral N down the soil profile even up to 170 cm. Presence of mineral N at 100-200 cm soil layers arising from leaching tally with the findings of Budelman (1988) in his study. Amount of mineral N (top soil) at the end of the season indicates how much N was available to the crop but was not used nor lost from soil-plant system (Kimetu, 2002). Nitrate is easily leached as noted by Tisdale et al. (1993), and the leaching potential increases with increasing rainfall (Myers et al., 1994). However losses of N through denitrification and volatilization were assumed to be negligible in this study; soils were well aerated hence no loss by denitrification and the soil pH ranging from 5.1 to 5.4 was not high enough to facilitate the process of volatilization (Myers et al., 1994; Mugendi et al., 2003). On the other hand, amount of N in the lower soil depths represent what had been moved beyond the crop rooting zone and could not be recovered by the crop as a result of asynchrony (Kindu et al., 1997; Mugendi et al., 1999b). According to Myers et al. (1994), asynchrony is said to occur when the nutrients are released at a rate exceeding the uptake or slower than the plant needs which seemed to be the case at Embu trial. Results at this trial showed accumulation of nitrate-N in the lower depths suggesting a downward movement of nitrate-N

from the top soil layers and an accumulation in the lower ones (Mugendi et al., 2003).

Conservation and maintenance of SOM is known to minimize leaching and concentrate N in the top-soil within the maize rooting zone. This is possible if organic resources used are of different quality which has a direct effect on mineralization and N release patterns (Xu et al., 1993). Also increased N-use efficiency as suggested by Becker et al. (1994a) will minimize opportunities for N loss (Myers et al., 1994). Slow N decomposition and an extended period with N immobilization may partially help reduce leaching (Thomsen and Christensen, 1998).

Conclusion

Crop response to nutrient applications depends on nature of the season especially rainfall amount and distribution. This was well demonstrated at PM1 trial where evenly distributed rainfall greatly contributed to increased crop yields. This was attributed to lack of moisture deficits which enhanced fertilizer N uptake leading to higher recoveries. Also SOM status as a result of resource quality especially in calliandra minimized N leaching and enhanced its uptake. Therefore, there was improved N uptake from both soil and applied fertilizer with evenly distributed rainfall at PM1 trial.

Nitrogen is only beneficial for increased N recovery if there is sufficient moisture. Addition of nitrogen during a poor season has been shown to lead to low recoveries. This was observed at N1 trial where poorly distributed rainfall caused soil moisture deficits leading to poor fertilizer N uptake and recoveries. A lot of mineral N was found in the plough layer due to lack of sufficient moisture to move it downwards. The same happened to organically bound N where so much was also left in the plough layer.

Acknowledgements

The study was part of on-going work by Tropical Soil Biology and Fertility (TSBF) in conjunction with the Kenya Agricultural Research Institute (KARI). I am grateful for the financial support received from the Rockefeller Foundation(s) Forum for Agricultural Resource Husbandry. I also wish to thank staff at the Laboratory for Soil Fertility and Soil Biology, Katholieke Universiteit, Leuven, Belgium for their

assistance in isotope analysis. Also special thanks to TSBF laboratory technicians for their assistance in mineral N analysis

References

- Anderson J.M. and Ingram J.S.L. 1993. Tropical Soil Biology and Fertility: A hand book of methods. CAB International, Wallingford, and U.K.
- Andreux F., Cerri C., Vose P.B. and Vitorello V.A. 1990. Potential of stable isotope, ^{15}N and ^{13}C , methods for determining input and turnover in soils. In: Harrison A.F., Ineson P., Heal O.W. (Eds.) Nutrient cycling in terrestrial ecosystems: Field methods, application and interpretation. Elsevier Applied Science 22: 259-275.
- Atwell B.J., Fillery I.R.P., McInnes K.J. and Smucker A.J.M. 2002. The fate of carbon and fertilizer nitrogen when dryland wheat is grown in monoliths of duplex soil. *Plant and Soil* 241: 259-269.
- Bacon P.E. 1995. Nitrogen turn over in the environment. Marcel Dekker, Inc. New York.
- Becker M., Ladha K.J. and Ottow J.C.G. 1994a. Nitrogen losses and lowland rice yield as affected by residue nitrogen release. *Soil Sci. Soc. Am. J* 58: 1660-1665.
- Breland T.A. and Hansen S. 1996. Mineralization and microbial biomass as affected by soil compaction. *Soil Biol. Biochem.* 28: 655-663.
- Budelman A. 1988. The decomposition of the leaf mulches of *Leucaena leucocephala*, *Gliricidia sepium* and *Flemingia macrophylla* under humid tropical conditions. *Agroforestry Systems* 7: 33-45.
- Buresh R.J. and Giller K.E. 1998. Strategies to replenish soil fertility in African smallholder agriculture. In: Soil fertility research for maize-based farming systems in Malawi and Zimbabwe. Proceedings of the Soil Fertility Network Results and Planning Workshop, African University Mutare, Zimbabwe.
- Cadisch G., Ferreira E., Uruquiga S., Giller K.E. and Boddey R.M. 1993. Nitrogen turnover in a red Latosol: Effect of added Carbon in incorporation of ^{15}N into soil organic matter. In: Mulongoy K. and Merckx R. (Eds.) Dynamics and sustainability of tropical agriculture. John Wiley and Sons.
- Chirwa T.S., Mafongoya P.L., Mbewe D.N.M. and Chichala B.A. 2004. Changes in soil properties and effects on maize productivity following *Sesbania sesban* and *Cajanus cajan* improved fallow systems in Eastern Zambia. In: Bationo A. (Ed.) Managing nutrient cycles to sustain soil fertility in Sub-Saharan Africa. 6: 89-112.
- Christianson C.B., Bationo A., Henao J. and Vlek P.L.G. 1990. Fate and efficiency of N fertilizers applied to millet in Niger. *Plant and soil* 61: 7-18.
- Craswell E.T. and Lefroy R.D.B. 2001. The role and function of organic matter in tropical soils. *Nutrient Cycling in Agroecosystems* 61: 7-18.
- De Vos J.A., Heterberg D. and Raats P.A.C. 2000. Nitrate leaching in a tile-drained silt loam soil. *Soil Sci. Soc. Am. J* 64: 517-52.
- Dilz K. 1988. Efficiency of uptake and utilization of fertilizer nitrogen by plants. In: Jenkinson D.S. and Smith K.A. (Eds.) Nitrogen efficiency in agricultural soils. Elsevier Applied Science, London.
- FAO 1990. FAO-UNESCO soil map of the World Revised legend. *Soils Bulletin* 60 FAO Rome.
- Fisher R.A. 1935. *The Design of Experiments*, 1st ed. Oliver and Boyd, Edinburg and London.

- GenStat 2002. Version 6.1, Lawes Agricultural Trust, Rothamstead Experimental Station, UK.
- Haggar J.P., Tanner E.V.J., Beer J.W. and Kass D.C.L. 1993. Nitrogen dynamics of tropical agroforestry and annual cropping systems. *Soil Biol. Biochem* 25: 1363-1378.
- Hood R. 2001. Plant N uptake from plant and animal organic residues measured using ^{15}N isotope dilution approach. In: Vanlauwe B., Diels J., Sanginga N. and Merckx R. (Eds.) *Integrated plant nutrient management in Sub-Saharan Africa: From concept to practice*. CAB International, Wallingford, UK.
- ICRAF 1995. Laboratory methods for soil analysis and plant analysis. Version 1.1 Nairobi, Kenya.
- Isherwood K.F. 2000. Mineral fertilizer use and the environment. International fertilizer Industry Association, Paris, France, pp. 51.
- Jama B.A., Nair P.K.R. and Rao M.R. 1995. Productivity of hedgerow shrubs and maize under alley cropping and block planting systems in semi-arid Kenya. *Agroforestry systems* 31: 257-274.
- Kamanga B.C.G., Kanyama G.Y. and Minae S. 2000. Maize production under tree-based cropping systems in Southern Malawi: A COBB-Douglas APPROACH. *African Crop Science Journal* 8: 429-440.
- Kamoni P.T., Mburu M.W.K and Gachene C.K.K. 2003. Influence of irrigation on maize growth, yield and nitrogen uptake in a Semi-Arid environment in Kenya. *Soil Science Society of East Africa proceedings of the 18th Conference and end of the millennium celebrations 4th-8th December 2000*. pp. 497-505.
- Kang B.T. and Van der Heide J. 1985. Nitrogen management in farming systems in humid and sub-humid tropics. Institute for Soil Fertility (IB) and International Institute of Tropical Agriculture (IITA), Netherlands.
- Kimetu J.M. 2002. Nitrogen fertilizer equivalency values for organic materials of contrasting qualities based on maize performance at Kabete, Kenya. MSc thesis, Kenyatta University, Kenya.
- Kindu M., Buresh R.J. and Bashir J. 1997. Root and inorganic nitrogen distribution in sesbania fallow and maize fields. *Plant and Soil* 188: 319-327.
- Ledgard S.F. and Smith G.S. 1992. Fate of ^{15}N -labelled fertilizer applied to Kiwifruit (*Actinidia deliciosa*) vines. II. Temporal changes in ^{15}N within vines. *Plant and soil* 147: 59-68.
- Li H., Parent L.E., Karam A. and Tremblay C. 2003. Efficiency of soil and fertilizer nitrogen of a sod-potato system in the humid, acid and cool environment. *Plant and Soil* 251: 23-36.
- Ma B.L. and Dwyer L.M. 1998. Nitrogen uptake and use of two contrasting maize hybrids differing in leaf senescence. *Plant and Soil* 199: 283-291
- Merckx R., Diels J., Vanlauwe B., Sanginga N., Deneff K. and Oorts K. 2001. Soil organic Matter and soil fertility. *Soil Sci Soc Am. J* 58: 69-89.
- Moutonnet P. and Fardeau C. 1997. Inorganic nitrogen in soil solution collected with tensionic samplers. *Soil Sci. Soc. Am. J* 61: 822-825.
- Mugendi D.N., Nair P.K.R., Mugwe J.N., O'Neill M.K., Swift M.J. and Woome P.L. 1999b. Alley cropping of maize with calliandra and leucaena in the subhumid highlands of Kenya: Part 2. Biomass decomposition, N mineralization, and N uptake by maize. *Agrofor. Syst* 46: 51-64.
- Mugendi D.N., Nair K.R., Graetz D.A., Mugwe J.N. and O'Neill M.K. 2000. Nitrogen recovery by alley-cropped maize and trees from ^{15}N -Labeled tree biomass in the subhumid highlands of Kenya. *Biol. Fertil. Soils* 31, 97-101.
- Mugendi D.N., Mucheru M., Kung'u J., Otor S., Micheni A. and Mugwe J. 2001. Soil fertility improvement strategies for increased food production in the central highlands of Kenya. *African Crop Science Conference Proceedings held in Lagos 22nd-26th October 2001*. pp. 897-904.
- Mugendi D.N., Kanyi M., Kung'u J., Wamicha W. and Mugwe J.N. 2003. Mineral-N movement in an agroforestry system in central highlands of Kenya. *Soil Science Society of East Africa proceedings of the 18th Conference and end of the millennium celebrations 4th-8th December 2000*. pp. 287-297.
- Myers R.J.K., Palm C.A., Cuevas E., Gunatilleke I.U.N. and Brunsard M. 1994. The synchronization of nutrient mineralization and plant nutrient demand. In: Woome P.L., Swift, M.J. (Eds.) *The biological management of soil fertility*. John Willey and Sons, Chichester, UK pp. 83-243.
- National Research Council 1993. *Soil and water quality: An agenda for agriculture*. National Academy Press, Washington. D.C. 6: 237-782.
- Nommik H. 1990. Application of ^{15}N as a tracer in studying nitrogen transformations and recovery in coniferous ecosystems In: Harrison A.F., Ineson P. and Heal O.W. (Eds.) *Nutrient cycling in terrestrial ecosystems: Field methods, application and interpretation*. Elsevier Applied Science Publishers, New York.
- Nziguheba G. 2001. Improving phosphorus availability and maize production through organic and inorganic amendments in phosphorus deficient soils in Western Kenya. Doctoral thesis, Katholieke Universiteit, Leuven, Belgium.
- Okogun J.A., Sanginga N. and Mulongoy K. 2000. Nitrogen contribution of five leguminous trees and shrubs to alley cropped maize in Ibadan, Nigeria. *Agroforestry Systems* 50:123-136.
- Olson R.A. and Kurtz L.T. 1982. Crop nitrogen utilization and fertilization. In: Stevenson F.J. (Ed) *Nitrogen in agricultural soil*. Soil Sci. Soc. Am USA.
- Palm C.A., Giller K.E. and Swift M.J. 2000. Soil organic matter: An overview. In: *The Biology and Fertility of Tropical soils: A TSBF Report 1997-98*. pp. 46-48.
- Palm C.A., Gachengo C.N., Delve R.G., Cadisch G. and Giller K. 2001. Organic inputs for soil fertility management in tropical agroecosystems: Application of organic resource database. *Agriculture, Ecosystems and Environment* 83: 27-42.
- Rao E.V.S.P. and Rattanna K. 2000. Nitrates, agriculture and environment. *Current Science* 79: 1163-1168.
- Thomsen I.K. and Christensen B.T. 1998. Cropping system and residue management effects on nitrate leaching and crop yields. *Agri, Ecosys and Env* 68: 73-84.
- Tisdale S.L., Nelson W.L., Beaton J.D. and Halvin J.L. 1993. *Soil fertility and fertilizers*. (5th Edition). Macmillan, New York, USA.
- Smith J.L. 1994. Cycling of nitrogen through microbial activity. In: Hatfield J.L. and Stewart B.A. (Eds.), *Soil Biology: Effects of soil quality: Advances in soil science*. Lewis Publishers, London.
- Stenger R., Priesack E. and Beese F. 1998. Distribution of inorganic nitrogen in agricultural soils at different dates and scales. *Nutrient Cycling in Agroecosystems* 50: 291-297.
- Vanlauwe B., Diels J., Duchateau L., Sanginga N. and Merckx R. 1998. Mineral N dynamics in bare and cropped *Leucaena leucocephala* and *Dactyloctenium aegyptium* alley cropping systems after the addition of ^{15}N -labeled leaf residues. *European Journal of Soil Science* 49: 417-425.
- Xu Z.H., Saffigna P.G., Myers R.J.K. and Chapman A.L. 1993. Nitrogen cycling in leucaena (*Leucaena leucocephala*) alley cropping in semi arid tropics. *Plant and Soil* 148: 63-72.

Performance evaluation of various agroforestry species used in short duration improved fallows to enhance soil fertility and sorghum yields in Mali

Bocary Kaya^{1*}, Amadou Niang², Ramadjita Tabo³ and André Bationo⁴

¹Institut d'Economie Rurale seconded to ICRAF Sahel Program, BP 320 Bamako, Mali; ²World Agroforestry, Centre Sahel Program, BP 320 Bamako, Mali; ³International Crops Research Institute for the Semi Arid Tropics, ICRISAT Niamey, BP 12404, Niamey, Niger; ⁴Tropical Soil Biology and Fertility, AfNet-TSBF/CIAT, P.O. Box 30677, Nairobi, Kenya; *Tel: (223) 232 24 66, (223) 676 19 90; Fax: (223) 222 86 83; Email: b.kaya@icrisatml.org

Abstract

The general soil fertility and crop yield decline constraints have guided the Malian agricultural research institute (Institut d'Economie Rurale, IER), the Sahel Program of the World Agroforestry Centre (ICRAF) and the International Crops Research Institute for the Semi Arid Tropics (ICRISAT) to join efforts and undertake research activities aimed at mitigating the constraints in Mali. Thus, from the year 2000, 14 different trees and shrubs are being tested in improved fallow systems to find which ones perform best to replenish soils and improve crop yields. The results have (i) identified most suited species for 1 or 2 yr improved fallows, (ii) determined their impact on sorghum grain yields and (iii) documented the remnant effects of their impact on soil fertility and crop yields.

Some species (*Indigofera astragalina*, *Crotalaria ochroleuca*, *Crotalaria agatiflora*, *Crotalaria retusa*, *Crotalaria goreensis*, *Crotalaria paulina* et *Tephrosia vogelii*) could not survive more than 1 year the Samanko conditions. Among them, *C. agatiflora* (1944, 1141 and 741 kg sorghum grain yields ha⁻¹ respectively in years 1, 2 and 3 after cultivation) and *I. Astragalina* (1343, 1301 and 393 kg sorghum grain yields ha⁻¹ respectively in years 1, 2 and 3 after cultivation) would be the best candidates for 1-yr improved fallows. Others such as *Tephrosia candida*, *Sesbania sesban* (Lery, Gache, Kibwezi and Kakamega provenances), *Cassia sieberiana* and *Cajanus cajan* have completed 2-yr duration improved fallows. In 2002, the first year of cultivation, it was the Kenyan provenances of *Sesbania sesban* which performed best with sorghum grain yields over 2 t ha⁻¹. A year later, 2003, there has been a general decrease in crop yield. Again, the Kenyan provenances of *S. sesban*, with yields 40% lower than the first year of cultivation, were the worst affected by this decrease. No significant changes were observed in the traditionally tested chemical soil parameters. In conclusion, *C. agatiflora*, *I. astragalina* and the Kenyan provenances of *S. sesban* are well-adapted species for 1-yr improved fallow systems in the Samanko, Mali, conditions

Key words: Agroforestry species, natural resources management, remnant effects, residues, Sahel, soil fertility, sorghum

Introduction

The weather prevailing in the Sahelian zone covering Senegal, Mali, Niger and Burkina Faso is characterized by a short (3 to 4 months), poor and erratic rainy season (400 to 1000 mm/year) with frequent drought

spells. Temperatures in the dry season (about nine months) can be as high as 40°C. Population growth rates in this region are among the highest in the world (about 3% per year) and are exacerbated by strong pressure on arable lands, which create ideal conditions

for over-exploitation of natural resources, leading to degradation.

Soils are affected by nutrients losses estimated at 25 kg N, 3 kg P and 20 kg K annually as well as organic matter losses ranging from 2 to 4% per year. Fertilizer use in the Sahel only increased by 0.6% over the last 10 years, as against 4.4% in other regions such as South East Asia and Europe (FAO, 1999). The region's needs in N, P and K are estimated at approximately 8 tonnes per year, which is 6 times higher than the total annual consumption levels (Sanchez et al., 1997). For the specific case of Mali, N, P and K budgets estimated in 1992 at national level (van der Pol, 1992) were all negative (-25, -20 and -5 kg ha⁻¹ respectively) which shows that about 40 to 60% of agricultural income is generated by mining of soil resources. As farmers adopt different soil management strategies on their farms, Kanté et al. (1998) investigated the situation at plot level and confirmed the trends highlighted by van der Pol (1992). Their results also proved that farmers, who are usually taken to be the best managers of their own land, also seem to be the very ones who most impact negatively on soil fertility.

Soil fertility decline is a major constraint to land productivity in the Sahel. Recent research findings have showed that under similar rainfall and moisture conditions, current land productivity levels could increase five times with an adequate fertilizer regime (Penning de Vries and Djiteye, 1982; Breman, 1998). Active soil erosion as a consequence of natural resource degradation, the rate of which is estimated to be ten times faster than soil formation, affects 72% of arable land. Indeed, fine particles and other fine elements carried away through the erosion processes are 2.5 times richer than the remaining soil. This is an additional land productivity limiting factor in the region. Moreover, the low productivity of major crops has led to an extension of agricultural areas into marginal lands not suitable for farming which, in turn, reduces the size of pasture areas. This situation further exacerbates the already strained relationships between farmers and pastoralists.

Sound soil fertility management is today a prerequisite. Traditional practices based on long duration fallows, crop rotation and use of organic fertilizers (domestic waste, manure, compost, etc.) have become either inappropriate or very difficult to implement due to several technical and socio-economic constraints affecting our production systems (Bationo and Mokwunye, 1991). Unfortunately, the use of mineral fertilizers which was for years considered as an efficient

means of increasing crop yields has showed limitations and is not affordable by the majority of African farmers.

It is increasingly confirmed that soil fertility management in the Sahel should necessarily be achieved through the use of organic and mineral fertilizers whereby organic matters could provide the nitrogen needed while phosphorous and other nutrients shall be provided by mineral fertilizers.

The general soil fertility decline trend observed in the Sahel has guided the Institut d'Economie Rurale (IER), the Sahel Programme of the world Agroforestry Centre (ICRAF/Sahel) and the International Centre for Research on Crops in Semi Arid Tropical Zones (ICRISAT) to launch joint research activities aimed at finding appropriate solutions to the soil fertility decline constraint. Thus, starting from the year 2000, a series of introduction trials of different agroforestry species and provenances were initiated at the ICRISAT Samanko Research Station, Mali, in an improved fallow system.

The general objective is to identify fast growing species, which keep their foliage in the dry season while producing large amounts of quality biomass, which can be used as nutrients by plants when incorporated in the soil. This practice improves crop yields after the fallow period. Specific objectives include, among others, (1) to identify nitrogen-fixing woody and non-woody species capable of producing large amounts of high quality biomass to speed up regeneration of the fertility of soils under fallow, (2) to reduce soil fertility maintenance cost through increased use of locally available materials (organic matter and rock phosphates), and (3) to detect the pace at which symptoms of deficiencies in major mineral nutrients (N, P, K) occur during the cropping phase after the fallow period. Specific recommendations can then be made for better soil fertility management after the fallow period.

Materials and methods

Site

The trial was established in 2000 at the Samanko Agronomic Research Station (331 m of altitude, 8°04' North and 12°54' West) located 25 km South-West of Bamako. Local soils are light, generally brown-yellow, of a tropical ferruginous washed-type with a pH ranging from 4.5 to 6.0 and poor in organic matter. The weather on site is characterized by one single rainy season from June to October followed by a long, dry and cold (December to February) and hot (from March to

May) season. The rains are erratic, with downpours at the onset of the season, pounding on bare soils without any plant cover and affected by intense erosion due to the heavy rainfall impact, which significantly reduces water infiltration. Rainfall levels recorded vary considerably over time and space. The region has recorded over the last thirty years a gap of about 100 mm of isohyets. Rainfall levels recorded between 2000 and 2003 are 919 mm, 978.9 mm and 1159.5 mm respectively.

Plant material

The material used includes 14 non coppicing pluri-annual species and provenances. The list is presented in Table 1 below.

Establishment /Conduct of the trial

The trial was conducted in a plot, which, after several years of cropping, was planted to sorghum without any fertilizer application in 1999, that is, one year before the trial. Plants were produced in a nursery during 4 months and had a height of 1 m for *Sesbania* and *Crotalaria* and 50 cm for *Tephrosia* at planting. They were planted after ploughing at 10 to 15 cm depth using a tractor at the beginning of the rainy season with a 0.75 m spacing between lines and 0.50 m on the line for a total population of 26,667 plants per hectare. Net plots are 6 m × 6 m or 36 sq. meters. Plots were weeded at trial installation year in order to mitigate the impact of

weed competition and they were protected from animal intrusion.

In 2002 and 2003, after planting, aerial biomass was cut low and separated as wood and leaf and quantities obtained were recorded. Leafy biomass was incorporated at ploughing to provide nutrients to the crop (sorghum ICSV 400). The sorghum was planted at intervals of 0.75 m between lines and 0.30 m on the line, thinned to two plants per hill for a total population of roughly 89,000 plants per hectare. Additional mineral fertilizer (40 kg of P ha⁻¹) was applied as super triple phosphate 15 days after planting. An initial weeding regime was done one week after planting, followed by another one month after.

Soils samples were taken at 0–20 cm and 20–40 cm depth in five locations following the 2 diagonals of each plot. For each depth, the 5 samples were well mixed and a representative 500 to 800 g sample was taken to analyze standard chemical parameters (water pH, N, P, K, Ca, Mg, CEC, C and organic matter). Samples were taken on the year of trial installation before crops were planted and also every year at the end of the cropping season after harvest.

Data collected during the fallow period include the rate of survival of species and provenances (by mere counting) and production of litter using wooden traps with a 1 m × 0.50 m or 0.50 m² metal sieve at the bottom, placed in three locations diagonally in each plot. Litter was collected every 15 days starting from the 5th month after planting and only in the dry season. At each collection date, the litter was oven-dried at 40°C before the dry weight was computed using an electronic scale.

Table 1. Species which do not sprout following cutting, tested under improved fallows at Samanko in 2000

Species	Provenances	Countries
<i>Cajanus cajan</i>	Samanko	Mali
<i>Cassia sieberiana</i> **	Fada	Burkina Faso
<i>Crotalaria agatiflora</i>	South Nyanza	Kenya
<i>Crotalaria goreensis</i>	Samanko	Mali
<i>Crotalaria ochroleuca</i>	Seaya	Kenya
<i>Crotalaria paulina</i>	G.B.K.	Kenya
<i>Crotalaria retusa</i>	Samaya	Mali
<i>Indigofera astragalina</i>	Ségou	Mali
<i>Sesbania sesban</i>	Lery	Burkina Faso
<i>Sesbania sesban</i>	Gachie	Kenya
<i>Sesbania sesban</i>	Kibwezi	Kenya
<i>Sesbania sesban</i>	Kakamega	Kenya
<i>Tephrosia candida</i>	Mararana	Madagascar
<i>Tephrosia vogelii</i>	Yaounde	Cameroon

Experimental design

A randomised complete block design was used, with 3 replications. Continuous sorghum treatments and natural fallow were added to the list of species, which gave a total of 16 treatments:

- T1: *Tephrosia candida*
- T2: *Sesbania sesban* (Lery)
- T3: *Indigofera astragalina*
- T4: *Crotalaria ochroleuca*
- T5: *Sesbania sesban* (Gachie)
- T6: *Crotalaria agatiflora*
- T7: *Sesbania sesban* (Kibwerzi)
- T8: *Crotalaria retusa*
- T9: *Sesbania sesban* (Kakamega)
- T10: *Crotalaria goreensis*

- T11: *Cassia sieberiana*
 T12: *Cajanus cajan*
 T13: *Crotalaria paulina*
 T14: *Tephrosia vogelii*
 T15: Natural fallow
 T16: Continuous cropping

Statistical analysis

All data collected were input using Microsoft Excel 2000 and converted into PRN text files. The analysis of variance was then performed with the SAS software version 6.12. Mean Treatment means were compared through the least small significant difference (Lsd) at a 5% confidence interval.

Results

Some species did not survive in the dry season of year 1 (2000) and corresponding plots were cropped from 2001. Other plots were planted in 2002, after a two-year fallow period.

Species used after one single year of fallow

The following species did not survive more than one year of fallow: *Indigofera astragalina*, *Crotalaria ochroleuca*, *Crotalaria agatiflora*, *Crotalaria*

retusa, *Crotalaria goreensis*, *Crotalaria paulina* and *Tephrosia vogelii*. In the aspect of leaf biomass production at the end of the fallow phase, *C. paulina* and *T. vogelii* were especially the best species with annual average production of dry matter of 2.5 t ha⁻¹ while *I. astragalina* and *C. ochroleuca* had the lowest production (Table 2). For sorghum grain yields after the fallow period, Table 2 indicates a production of about 2 t ha⁻¹ in 2001 for *C. agatiflora* which also yielded dry leaf biomass almost similar to that of the best two species. The following species then came next, in decreasing order: *C. paulina*, *I. astragalina* and *T. vogelii*. In 2002, not only a global sorghum grain yield decline was recorded but a new classification of treatments was also made. Thus, in 2002, *C. paulina* was the best yielder, followed by *C. goreensis* and *C. agatiflora*. In all cases, *C. retusa* and continuous cropping produced the lowest levels. The general yield decline was further exacerbated in 2003, after 3 years of uninterrupted cropping. *C. agatiflora*, *C. paulina* and *T. vogelii* were the most affected by yield drops (Figure 1).

Soil analysis data are presented in Table 3. They show a significant difference between 0–20 cm and 20–40 cm horizons for all parameters studied. Generally, horizon 0–20 cm is the most acid and richer in phosphorous, potassium and carbon than horizon 20–40 cm. CEC is however slightly higher in the 20–40 cm horizon. A comparison between treatments shows that *C. goreensis*, *C. ochroleuca*, *C. agatiflora* and *T. vogelii* produced a higher P content in the 0–20 cm layer. For all other parameters and at all

Table 2. Production of dry leaf biomass by agroforestry species which do not stand the cutting process and their impact on sorghum yields after a one-year fallow at Samanko station, Mali

Species	Leaf Biomass	Sorghum grain yield (kg ha ⁻¹)			
		2001	2002	2003	Aggregate
<i>Indigofera astragalina</i>	304	1343	1301	394	3037
<i>Crotalaria ochroleuca</i>	732	1065	836	417	2318
<i>Crotalaria agatiflora</i>	2215	1944	1141	741	3826
<i>Crotalaria retusa</i>	1768	787	680	301	1768
<i>Crotalaria goreensis</i>	1870	1157	1187	463	2807
<i>Crotalaria paulina</i>	2571	1389	732	324	2445
<i>Tephrosia vogelii</i>	2420	1343	848	509	2700
Natural fallow	na	972	899	444	2311
Continuous cropping	na	694	565	370	1630
Probability	0,0001	0.28	0.17	0.144	0.16
LSD	487.93	964.93	572.46	288.93	1284.20
CV (%)	16.16	46.9	36.34	37.95	35.35

na: not available.

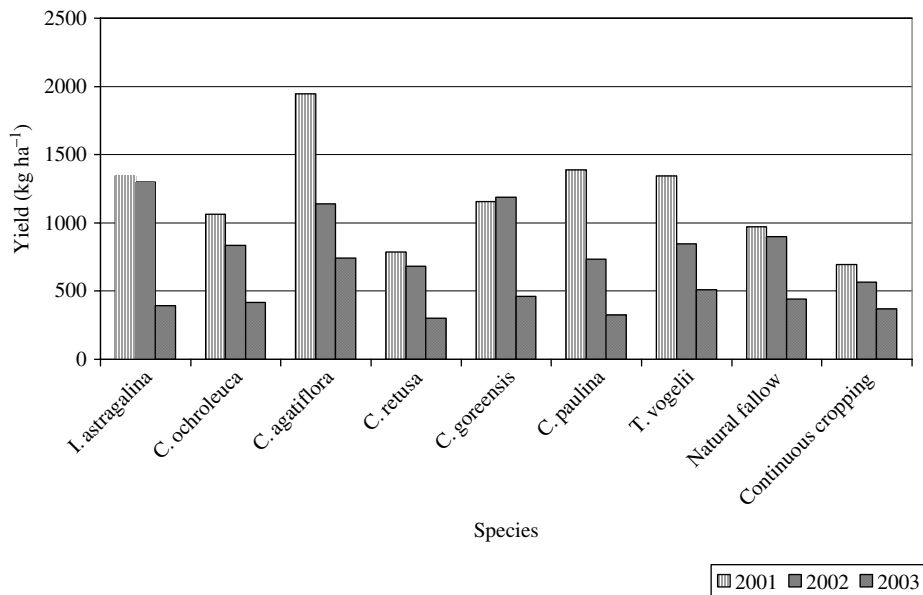

Figure 1. Sorghum yield trends after a one-year improved fallow at the Samanko station, Mali.

horizons, only *C. agatiflora* produced results comparable with those at the initial state, before the trial was established.

Species submitted to a two-year fallow

Table 4 presents the results of litter production for species which were submitted to a two-year fallow before being planted anew in 2002. Litter production fluctuated from one year to another with an increase noted for *T. candida*, *S. sesban* (Kibwezi and Kakamega) and *C. sieberiana* and a slight drop for *S. sesban* (Lery and Gaché) and *C. cajan*. In all cases, *Cajanus cajan* produced the highest amount of litter. Cumulated data for the two years show the best species as being *C. cajan* > *T. candida* > *C. sieberiana*.

For sorghum grain yields in 2002 (first year of cultivation), *Sesbania sesban* provenances were the best species, with annual average production above 2 t ha⁻¹ (Table 5). Such yields are at least 3.5 times higher than that of the continuous cropping and almost twice higher than that of the natural fallow. Despite significant leaf biomass produced during the fallow phase, *C. cajan* proved to be the least productive in the first year, with grain yields lower than that of the natural fallow. This may be explained by the fact that litter

produced during the fallow phase may not have been entirely maintained in the plot and that the species suffered from a high mortality rate in the dry season just before the trial was planted, due to termite attack. In 2003, the second year of cultivation, a sorghum yield drop was noted as compared to the previous year for all treatments. This was particularly noted on *Sesbania sesban* Kenyan provenances, with yields 40% lower than the previous year of cultivation (Figure 2). In addition, mean different treatments are not statistically different at a 5% threshold (table 5). The above results could partly be due to the very nature of the biomass produced by such species as it is high in N, with a very low C:N ratio and a low lignin content. All these features contribute to a rapid decomposition rate (Table 6).

Similarly, the significant leaf biomass obtained from *C. sieberiana* (about 4 times higher than that of the other species) only produced lower yield compared to the natural fallow. It therefore could be suggested to use *C. cajan* for a one (not two) year fallow species.

As the amount of biomass produced is very important for plant nutrition after the fallow phase, samples were taken for more in-depth analysis to determine their content in mineral elements and also to pinpoint some chemical characteristics strongly correlated with the decomposition rate (Table 6). Such data were used to estimate amounts of nutrients released in the soil by each species (Table 7).

Table 3. Results of soil analysis in the 1st year of cultivation after a one-year fallow

	pH		P		K		Ca		Mg		CEC		Corg	
	20 ¹	40 ²	20	40	20	40	20	40	20	40	20	40	20	40
	mg kg ⁻¹													
	meq 100 g ⁻¹													
	%													
<i>Indigofera astragalina</i>	5.07	5.15	4.06	1.47	0.30	0.21	1.09	1.23	0.41	0.49	1.99	2.17	0.33	0.24
<i>Crotalaria ochroleuca</i>	4.71	4.96	3.45	1.40	0.35	0.23	0.81	1.01	0.36	0.44	1.86	2.04	0.33	0.25
<i>Crotalaria agatiflora</i>	4.85	5.22	4.09	1.99	0.34	0.23	1.25	1.59	0.50	0.55	2.41	2.66	0.39	0.25
<i>Crotalaria retusa</i>	4.87	5.05	3.11	1.34	0.28	0.21	0.79	0.81	0.38	0.36	1.76	1.83	0.30	0.23
<i>Crotalaria gorensis</i>	4.99	5.14	3.15	1.10	0.36	0.20	0.98	1.14	0.40	0.47	1.99	2.11	0.36	0.27
<i>Crotalaria pennisilla</i>	5.04	5.09	3.56	1.52	0.29	0.22	0.79	1.11	0.34	0.48	1.69	2.08	0.33	0.27
<i>Tephrosia vogelii</i>	4.93	5.16	3.00	1.17	0.32	0.23	0.90	1.15	0.39	0.46	1.85	2.13	0.34	0.27
Natural fallow	4.76	4.97	3.05	1.25	0.30	0.22	0.91	1.16	0.41	0.47	1.90	2.15	0.33	0.26
Continuous cropping	4.81	5.06	3.01	1.55	0.29	0.23	0.85	0.97	0.36	0.40	1.85	1.92	0.32	0.24
Initial state	4.52	4.77	2.36	1.28	0.20	0.13	1.04	1.60	0.40	0.56	2.09	2.73	0.46	0.36
P treatment	0.062		0.211		0.050		0.124		0.407		0.057		0.004	
P depth	<0.001		<0.001		<0.001		<0.001		<0.001		<0.001		<0.001	
LSD treatment	0.251		0.881		0.064		0.391		0.128		0.410		0.050	
LSD depth	0.055		0.207		0.011		0.058		0.026		0.082		0.009	
CV treatment (%)	3.0		24.6		15.1		21.9		17.3		11.9		9.8	
CV depth (%)	2.8		23.9		11.2		13.5		14.9		9.9		7.4	

¹ 0–20 cm depth; ² 20–40 cm depth.

Table 4. Litter and leaf biomass production by species in trial 1 which were used in a two-year fallow at the Samanko station, Mali

Species	Litter	2001	Cumulated litter	Leaf biomass (2002)	Grand total
	2000				
kg ha ⁻¹					
<i>Tephrosia candida</i>	1940.2	2453.6	4393.8	309.6	4703.3
<i>Sesbania sesban</i> (Lery)	1214.4	934.4	2148.9	1180.5	3329.4
<i>Sesbania sesban</i> (Gaché)	1407.8	842.7	2250.4	274.3	2524.8
<i>Sesbania sesban</i> (Kibwezi)	973.8	1458.9	2432.7	774.2	3206.9
<i>Sesbania sesban</i> (Kakamega)	1234.7	1245.3	2480.0	309.5	2789.5
<i>Cassia sieberiana</i>	738.9	3058.7	3797.6	4281.2	8078.7
<i>Cajanus cajan</i>	4676.9	3855.1	8532.0	208.3	8740.3
Natural fallow	na	na	na	582.1*	582.1*
Continuous cropping	na	na	na	248.8*	248.8*
Probability	0.0001	0.0005	0.0001	0.0001	0.0001
LSD	541.71	1137.8	994.29	682.68	1329.3
CV (%)	17.49	32.32	15.02	43.45	15.67

* Shows the weight of biomass from the grass cover; na: not available.

Table 5. Sorghum yields after a two-year fallow with the species of trial 1 (conducted at the Samanko station, Mali)

Species	Grain Yields		Residues	
	2002	2003	2002	2003
kg ha ⁻¹				
<i>Tephrosia candida</i>	1369.3	740.74	6496	1210.83
<i>Sesbania sesban</i> (Lery)	2135.4	833.33	6440	1622.35
<i>Sesbania sesban</i> (Gaché)	1937.3	763.89	5951	1462.42
<i>Sesbania sesban</i> (Kibwezi)	2307.5	856.84	6444	1900.00
<i>Sesbania sesban</i> (Kakamega)	2036.6	763.89	6193	1563.24
<i>Cassia sieberiana</i>	1060.5	694.45	4664	1356.44
<i>Cajanus cajan</i>	1241.4	625.00	4553	1291.58
Natural fallow	1249.0	810.19	6060	1717.33
Continuous cropping	565.2	462.96	3252	1282.15
Probability	0.0001	0.060	0.06	0.024
LSD	573.59	368	2179	618.7
CV (%)	21.45	30.93	22.62	26.8

In general, *T. candida* and the four *S. sesban* provenances exhibit very high nitrogen contents (>3.5%), acceptable potassium contents and low lignin contents, to the exception of *T. candida*. They also have the lowest ratios, which account for the biomass decomposition rate (C: N, lignin:N and (lignin + phenolic composites):N). It should be noted, however, that phosphorous and magnesium rates are very low in all species. These results no doubt justify the use of *S. sesban* and *T. candida* which produced very good sorghum yields.

Soil analysis data (Table 8) are quite similar to those obtained with species used during only one year of fallow. Generally, horizon 0–20 cm is more acid, richer

in phosphorous, in potassium and in carbon but with a CEC lower than in horizon 20–40 cm ($p < 0.001$). Treatments differ one from the other in their potassium and carbon content (0–20 cm). *T. candida* and *S. sesban* (Lery) exhibit more P than others, followed by the three *S. sesban* provenances (Kakamega, Gachié and Kibwerzi). All treatments showed improvements as compared to the initial situation before the fallow phase. Regarding CEC, the soil initial state and *S. sesban*-based treatments (Lery and Kibwerzi) produced better results than other treatments in the 20–40 cm layer. However, soil carbon content at the initial state is higher as compared to all other treatments.

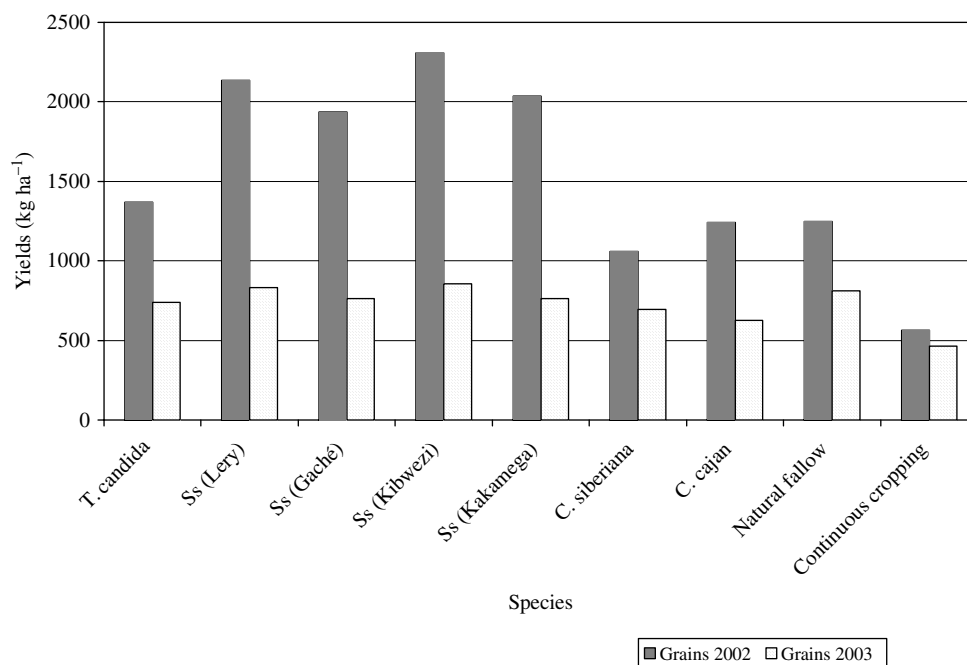

Figure 2. Sorghum yield trends after a two-year improved fallow at the Samanko station, Mali.

Table 6. Major fertilizing elements and some biochemical characteristics of species used in a one-year fallow

Species	N	P	K	Mg	PP	Lignin	C:N	Lig :N	(Lig+PP) :N
<i>T. candida</i> §	3.50	0.20	1.60	na	3.10	14.60	na	4.20	5.10
<i>S. sesban</i> (Lery)	3.60	0.13	1.92	0.30	2.01	3.85	13.16	1.07	1.63
<i>S. sesban</i> (Gaché)	3.80	0.20	2.16	0.24	1.67	5.63	12.38	1.48	1.92
<i>S. sesban</i> (Kibwezi)	3.55	0.16	1.92	0.34	2.01	5.90	12.94	1.66	2.23
<i>S. sesban</i> (Kakamega)	3.95	0.16	1.92	0.29	2.03	9.04	11.82	2.29	2.80
<i>C. sieberiana</i>	2.10	0.10	0.69	0.21	9.44	14.21	22.94	6.77	11.26
<i>C. cajan</i>	2.85	0.16	1.12	0.20	3.58	13.88	16.24	4.87	6.13
Natural fallow	1.70	0.12	2.78	0.23	1.32	5.66	23.41	3.33	4.11
Continuous cropping	2.05	0.11	2.22	0.37	1.31	6.29	19.02	3.07	3.71

§ From Niang et al. (2002); na: not available; PP: phenolic composites.

Conclusion

From these preliminary results, it can be concluded that there are certainly possibilities to implement a one-year fallow period with species such as *I. astragalina*, *C. paulina* and *C. agatiflora* in areas where rainfall varies between 700 and 800 mm per year to produce annual mean yields of about 1.5 t ha⁻¹ in the first year of cultivation.

In the first year (2002), Kenyan *Sesbania sesban* provenances outyielded all other species, with annual average production above 2 t ha⁻¹. In 2003, a yield decline was recorded as compared to the

previous year; this particularly affected *Sesbania sesban* Kenyan provenances which only produced 40% of their previous year levels. Results obtained elsewhere in East Africa confirm the significant drop in yields in the second year of cultivation of improved fallows using species not sprouting following cutting (personal observation made during field visits in Zambia, Paramu Mafongoya (2004): personal presentation). These results could be due to a loss of nitrogen (NO₃ and NH₄) through lixiviation on sandy and light soils (Mafongoya et al., 2003). It can then be concluded that such species could be used for just one cereal crop after a fallow period on sandy soils.

Table 7. Amounts of nutrients released by agroforestry species after the fallow period

Species	Quantities (kg ha ⁻¹)			
	N	P	K	Mg
<i>Tephrosia candida</i>	164.61	9.40	75.25	na
<i>Sesbania sesban</i> (Lery)	119.86	4.32	63.92	9.98
<i>Sesbania sesban</i> (Gaché)	95.94	5.05	54.53	6.06
<i>Sesbania sesban</i> (Kibwezi)	113.85	5.13	61.57	10.90
<i>Sesbania sesban</i> (Kakamega)	110.19	4.46	53.56	8.09
<i>Cassia sieberiana</i>	169.65	8.08	55.74	16.96
<i>Cajanus cajan</i>	249.10	13.98	97.89	17.47
Natural fallow	9.90	0.69	16.18	1.33
Continuous cropping	5.10	0.27	5.52	0.92
P	0.0001	0.0001	0.0001	0.0001
CV (%)	18.32	17.70	21.49	19.60
LSD	35.044	1.628	19.240	3.078

Table 8. Results of soil analysis conducted in the first year of cultivation after a two-year fallow

	pH		P		K		Ca		Mg		CEC		Corg	
	20 ¹ mg kg ⁻¹	40 ² mg kg ⁻¹	20	40	20	40	20	40	20	40	20	40	20	40
<i>Tephrosia candida</i>	4.94	4.90	3.18	0.93	1.34	0.20	1.04	1.02	0.50	0.44	2.18	2.04	0.35	0.25
<i>S. sesban</i> (Lery)	4.93	5.15	2.60	1.09	1.33	0.18	1.21	1.49	0.46	0.55	2.18	2.43	0.39	0.28
<i>S. sesban</i> (Gachié)	4.85	5.08	2.72	1.12	0.35	0.18	0.97	1.17	0.41	0.50	1.96	2.14	0.36	0.26
<i>S. sesban</i> (Kibwerzi)	4.92	5.05	2.65	1.07	0.33	0.19	1.10	1.39	0.42	0.55	2.09	2.36	0.36	0.26
<i>S. sesban</i> (Kakamega)	5.06	5.03	2.52	1.14	0.38	0.23	0.87	1.06	0.37	0.47	1.87	2.13	0.34	0.28
<i>Cassia siberianna</i>	4.91	5.31	2.77	0.82	0.28	0.18	0.94	1.04	0.55	0.47	2.04	2.01	0.40	0.25
<i>Cajanus cajan</i>	5.04	5.16	2.72	1.05	0.29	0.15	0.88	1.08	0.37	0.43	1.81	1.96	0.33	0.26
Natural fallow	4.76	4.98	3.05	1.24	0.30	0.21	0.91	1.16	0.41	0.47	1.91	2.15	0.33	0.26
Continuous cropping	4.81	5.07	3.01	1.55	0.29	0.23	0.85	0.96	0.36	0.40	1.85	1.92	0.32	0.24
Initial state	4.52	4.77	2.36	1.28	0.20	0.13	1.04	1.60	0.40	0.57	2.09	2.72	0.46	0.36
P treatment	0.062		0.211		0.050		0.124		0.407		0.057		0.004	
P depth	<0.001		<0.001		<0.001		<0.001		<0.001		<0.001		<0.001	
LSD treatment	0.251		0.881		0.064		0.391		0.128		0.410		0.050	
LSD depth	0.055		0.207		0.011		0.058		0.026		0.082		0.009	
CV treatment (%)	3.0		24.6		15.1		21.9		17.3		11.9		9.8	
CV depth (%)	2.8		23.9		11.2		13.5		14.9		9.9		7.4	

¹ 0–20 cm depth; ² 20–40 cm depth.

Soil physical and chemical properties did not change significantly one year after the cultivation of fallows. Agroforestry species are particularly efficient in supplying nitrogen to crops as they have high nitrogen contents. Considering the significant contribution of this nutrient in the soil, it would be recommended analyze fresh soil samples in order to monitor trends in the profile and develop strategies for a more efficient use.

References

- Bationo A. and Mokwunye A.U. 1991. Role of manures and crop residues in alleviating soil fertility constraints to crop production: With special reference to the Sahelian and soudanian zones of West Africa. In: Mokwunye A.U. (ed.) *Alleviating soil fertility constraints to increased crop production in West Africa*. Kluwer Academic Publishers, Dordrecht, The Netherlands, pp. 217–225
- Breman H. 1998. Amélioration de la fertilité des sols en Afrique de l'Ouest : Contraintes et perspectives. In: Renard G., Neef A., Becker K. and von Oppen M. (eds) *Soil Fertility Management in West African Land use Systems*. Proceedings of the Regional workshop. University of Hohenheim, ICRISAT Sahelian Centre and INRAN, Niamey Niger, 4–8 March 1997, pp. 7–20
- FAO 1999. Soil fertility initiative, Sub-Saharan Africa. <http://www.fao.org/Waicent/faoinfo/agricult/AGL/agln/psfi.htm> 18 February 1999
- Kanté S., Sanogo J.L.Z., Dembélé I., Koné D. and Kater L. 1998. Gestion de la fertilité des sols : qui mine le plus, le petit ou le grand? Contribution au 1er symposium international AOCA/RSP-GRN, Bamako, Mali, 21–25 septembre 1998. Sikasso, Mali, ESPGRN, 15p.
- Mafongoya P.L., Chintu R., Chirwa T.S., Matibini J. and Chikale S. 2003. *Tephrosia* species and provenances for improved fallows in southern Africa. *Agrof. Syst.* 59: 279–288.
- Niang A., Amadolo B.A., de Wolf J. and Gathumbi S.M. 2002. Species screening for short-term planted fallows in the highlands of western Kenya. *Agrof. Syst.* 56: 145–154.
- Penning de Vries, F.W.T. and Djiteye M.A. 1982. La productivité des pâturages sahéliens, une étude des sols, des végétations et de l'exploitation de cette ressource naturelle, Pudoc, Wageningen, The Netherlands. 525 pp.
- Sanchez P.A., Shepherd K.D., Soule M.J., Place F.M., Buresh R.J. and Izak A.-M. N. 1997. Soil fertility replenishment in Africa: An investment in natural resource capital. pp. 1–46. In: Buresh R.J., Sanchez P.A and Calhoun F. (eds) *Replenishing soil fertility in Africa*. SSSA Special Publication no. 51. Madison, WI: SSSA.
- van der Pol F. 1992. Soil Mining: An unseen contributor to farm income in southern Mali. Bulletin no. 325. Amsterdam, The Netherlands: Royal Tropical Institute.

Nutrient balances for different farm types in Southern Mali

S. Kanté¹, E.M.A. Smaling^{2,3}, H. van Keulen³

¹*Equipe des Systèmes de Production et Gestion des Ressources Naturelles (ESPGRN), Institut d'Economie Rurale (IER), BP 186 Sikasso, Mali; Tel.: 223 620 028; fax: 223 620349; e-mail: salif.kante@ier.ml;* ²*Group Soil Inventarisation and Land Evaluation, Environmental Sciences Group, Wageningen University and Research centre, Wageningen, the Netherlands;* ³*International Institute for Geo-Information Science and Earth Observation (ITC), P.O. Box 6, 7500 AA, Enschede, The Netherlands.*

Abstract

Soil nutrient mining is one of the main causes of the current stagnation, or even decline in crop yields in Southern Mali. Limited information is available on the impact on soil fertility of different management packages as implemented at different farm types. The aim of the current study was to analyse nutrient flows in agricultural systems in Southern Mali for different farm types in two villages, varying in pressure on the soil resource. In each of the villages, 20 farms were selected and classified in three classes on the basis of differential nutrient management. Partial nutrient balances (imports in fertilizers minus exports in grain and straw) and complete nutrient balances (including difficult-to-quantify flows) were established.

The results show that for cotton, the partial balances for nitrogen (N), phosphorus (P) and potassium (K) were positive, contrary to balances for millet-sorghum. Partial farm balances for nitrogen in the two villages varied between -2.5 and $12 \text{ kg ha}^{-1} \text{ a}^{-1}$. P-balances were positive, while those for K were generally negative. The deficits were more pronounced in systems based on cotton-millet/sorghum than in those based on cotton-maize. Complete farm balances were negative for N and K and positive for P. Without improvements in soil fertility management, soil nitrogen stocks will decrease by about half over the next 20 years

Key words: NPK balances; farm types; cotton/cereals/animal husbandry; soil fertility management; Mali

Introduction

The problem of stagnating or declining yields in the original cotton zones in Southern Mali is becoming increasingly serious. Maintenance of the production capacity of the soils is directly associated with the possibilities of avoiding negative soil nutrient balances. The general conclusion from earlier studies in Southern Mali is that the farmers in this zone produce at the expense of soil nutrient capital (Van der Pol, 1992; Smaling, 1993a; Camara, 1996; Cretenet, 1996). In the various systems, soil nutrient balances vary between -27 and -34 kg N ha^{-1} , 0 and 1 kg P ha^{-1} and -18 and -28 kg K ha^{-1} (Van der Pol, 1993). However, in Lanfiala (Southern Mali/Kadiolo)

balances for phosphorus and potassium were positive, while those of N were -3.2 ; -4.7 ; -21.4 and 23.3 kg ha^{-1} for the centre of the village, the hamlet, the outskirts of the village and the Peul encampments, respectively (Ramisch, 1999). Such a large variability in nutrient balances in Southern Mali, within a single village or even among different crops within a single farm, as also reported by Van den Bosch *et al.* (1998) and Scoones and Toulmin (1998), is a reason to critically examine such data, to avoid unjustified generalisations with respect to the magnitude of the losses.

Although such balances are invaluable indicators for a general evaluation of farming systems in a certain region, they can not be applied to evaluate specific technologies applied by different categories of farm

households on the fertility of their soils. The aim of this study was to analyse nutrient management by different categories of farm households in two locations distinguished by pressure on the resources and production technologies.

Materials and methods

Locations

The study was carried out in the villages of M'Peresso and Noyaradougou, located in the Cercles de Koutiala and Sikasso, respectively, the mandate area of the Compagnie Malienne pour le Développement des Textiles (CMDT), the cotton parastatal, in Southern Mali. The ratio of potentially cultivable land to area cultivated is 1.47 for the Cercle de Koutiala and 3.65 for the Cercle Sikasso (Schrader and Wennik, 1996). In M'Peresso 44% of the cultivated soils are sandy, compared to 13% in Noyaradougou (Kanté, 2001).

Farming system, sampling and vegetative material

From 1994 till 1997, 40 farm households have been monitored, i.e. 20 per village. The data (number of bags of chemical fertilizer, loads of organic fertilizer, forage, litter and compost) were collected in a participatory action-research approach, utilising various tools, such as nutrient flow maps, indicating farm inputs and outputs. The 40 farm households were classified on the basis of their soil fertility management strategy during a village meeting in three farm types, class I (good management), class II (medium management) and class III (unfavourable management). Characteristics of the three classes are given in Table 1.

The table shows that classes I and II are characterized by greater labour availability than class III. Moreover, class I owns about three times as many animals (TLU¹) as class III and 1.5 to 2 times as many as class II. Similar differences among the classes are also observed with respect to area cultivated, quantities of animal manure produced and utilized and farm equipment. The number of draught animals and equipment for transport diminishes from class I via class II to class III.

¹TLU is a Tropical Livestock Unit, a hypothetical animal of 250 kg liveweight.

Plant material refers to all the crops grown on the farm. The farming system is based on the cotton-cereal rotation. Cotton occupies 30% of the cultivated area in M'Peresso and 46% in Noyaradougou. The dominant rotation is cotton-sorghum/millet (84% of the area) in M'Peresso and cotton-maize (76% of the area) in Noyaradougou. Cotton and maize receive 99% of the organic manures in M'Peresso and 97% in Noyaradougou (Kanté, 2001).

Balance calculations

In the balance calculations, the data from the 40 farms, referring to the areas of the mixed crops, in terms of grain/straw ratio of the crops and N-contents of the soil have been considered in the balance calculations. Literature data have been used to convert measured quantities of animal manure, grains and crop residues to nutrient (NPK) quantities. Balances have been calculated per crop, per farm, per farm class and per village. In the calculations the fallow areas have not been considered.

Partial N, P and K farm gate balances

In calculating the partial nutrient balances only easily measurable nutrient flows have been taken into account. This refers to imports of nutrients in the form of mineral (IN1) and organic (IN2) fertilizers and exports in grains (OUT1) and crop residues (OUT2) (Smaling *et al.*, 1996). For better definition of the flows, the contribution from organic manures is sub-divided in material originating from the animal sector (IN2e: manure, excrements voided directly at the night camps, droppings of small ruminants, donkey dung), from the household (IN2m) and from poultry (IN2a). Exports in residues are sub-divided in those exported through animals (OUT2e: forage, bedding, residue grazing), through the household (OUT2m: inputs in compost pits and garbage heaps used for producing potassium salt) and through burning (OUT2b).

Residues left in the field, trampled by animals, and partly degraded by termites and incorporated in the soil at the time of soil preparation are considered 'neutral' for the system (internal recycling). In calculating the balance, it is assumed that nitrogen is completely lost during burning and that 10% of the phosphorus and potassium are lost (Camara, 1996).

Table 1. Structural characteristics and management of the different farm classes

Parameter	M'Peresso			Noyaradougou		
	Class I	Class II	Class III	Class I	Class II	Class III
Total working family members (#)	13	7	4	10	11	5
Working men (#)	7	4	3	4	5	2
Total cows (#)	27	13	5	13	8	3
Total TLU (#)	29	12	8	11	7	4
Area cultivated (ha)	19.8	12.3	8.4	12.8	9.4	6.4
Area cotton (ha)	7.5	4.3	2.8	6	4	2.8
Area maize (ha)	1.5	0.9	0.5	3.8	2.7	2
Area cereals (ha)	10.4	6.8	4.8	6.2	5	3.2
Area leguminous species (ha)	1.9	1.2	0.8	0.6	0.6	0.6
Animal manure (t)	20.7	10.2	5.7	6.7	2.7	2.5
Organic fertilizer (t)	59	24	14	14	7	9

(#) This refers to the average number per farm for the period 1994 to 1997, except for the number of draught animals (1996 to 1997). TLU: Tropical Livestock Unit with a standard weight of 250 kg. The maize area is included in that of cereals. Source: Kanté (2001).

Complete farm balances

In addition to the terms from the partial balances (IN1, IN2, OUT1 and OUT2), atmospheric deposition (IN3), biological nitrogen fixation (IN4), leaching losses (OUT4) and losses through erosion (OUT5) are taken into account. For calculating the difficult-to-quantify flows (IN3, IN4 and OUT5), the transfer functions developed by Stoorvogel and Smaling (1990a, b) have been used. To calculate the losses through OUT3 and OUT4, equations developed by Ndoumbe and Van der Pol (1999) have been used.

Atmospheric deposition (IN3)

Inputs through rain and dust are set to 5, 2.1 and 3.4 kg ha⁻¹ for N, P and K, respectively (Stoorvogel and Smaling, 1990a, b).

Biological nitrogen fixation (IN4)

It has been assumed that leguminous crops can satisfy 60% of their N requirements through symbiotic fixation and that all crops benefit from non-symbiotic nitrogen fixation. On the basis of the LWC (Land/Water Class; Stoorvogel and Smaling, 1990a, b) values of 4 and 5 kg ha⁻¹ a⁻¹ for non-symbiotic nitrogen fixation have been assumed for M'Peresso et Noyaradougou, respectively (Kanté, 2001).

Leaching losses (OUT3)

Leaching losses refer to N and K. The magnitude of the losses depends on soil physical properties (texture and structure), quantities of N and K fertilizers applied, nutrient retention capacity of the soil,

crop species and quantity and distribution of rainfall (IER/CMDT, 1987). In calculating leaching losses, it has been assumed that 8% of the nitrogen and 12% of the potassium applied in chemical fertilizer is lost (Kanté, 2001).

Nitrogen

$$\begin{aligned} \text{OUT3} &= \text{OUT3mo} + \text{OUT3f} \\ &= \text{PI} * \text{OUT3s} + 0.01 * \text{Pfix} * \text{PI} * \text{IN}(1 + 2)\text{ix} \end{aligned}$$

where,

- OUT3mo: Fixed leaching loss (base value associated with soil organic matter), kg ha⁻¹ a⁻¹
- OUT3f: Leaching loss associated with fertilizer application, kg ha⁻¹ a⁻¹
- PI: site-specific correction factor
- OUT3s: Standard leaching loss per soil type, kg ha⁻¹ a⁻¹
- Pfix: Fraction of fertilizer nutrient lost through leaching per crop/soil type combination (%)
- IN(1+2)ix: Nutrient applied in fertilizer, kg ha⁻¹ (where, i: dose, x: nutrient element)

According to Kanté (2001), PI equals 0.9 for M'Peresso and 1 for Noyaradougou, while OUT3s equals 8 and 12 kg ha⁻¹ a⁻¹ for the two locations, respectively.

Potassium For potassium, the same equations are being used. However, in calculating PI, a regression between nitrogen and potassium is introduced: PIK =

0.3015* PIN. Introducing the losses of N and K per crop according to Ndoumbe and Van der Pol (1999) in the regression equation yields a correlation coefficient (R^2) of 0.97.

Gaseous losses (OUT4)

Gaseous losses refer to nitrogen losses through denitrification and volatilization. Losses from manure vary from 17–36% and those from soil organic matter from 15–25 kg ha⁻¹ (Pieri, 1986; Gigou, 1986, both cited by Ndoumbe and Van der Pol, 1999).

$$\text{OUT4} = \text{OUT4b} + \text{OUT4f}$$

Where:

- OUT4b: Base gaseous losses for each crop, kg ha⁻¹ a⁻¹
 OUT4f: Gaseous losses for each fertilizer, kg ha⁻¹ a⁻¹

In calculating OUT4, the values for gaseous losses used by Van der Pol for Southern Mali have been used, i.e. 25% of the fertilizer nutrients and 12 kg ha⁻¹ a⁻¹ as base losses (Ndoumbe and Van der Pol, 1999).

Erosion (OUT5)

Losses through erosion are a function of erodibility and intensity of rainfall, slope, soil permeability and soil nutrient contents. The regression equations of Stoorvogel and Smaling (1990a) have been used in the calculations:

$$\text{OUT5(N)} = \text{EF} * \text{Nc} * \text{Pe};$$

$$\text{OUT5(P)} = \text{EF} * \text{Pc} * \text{Pe}$$

$$\text{OUT5(K)} = \text{EF} * \text{Kc} * \text{Pe}$$

Where:

- EF: Enrichment factor (–)
 Nc: Soil N content (%), derived from fertility class of FAO
 Pc: Soil P content (%), derived from fertility class of FAO
 Kc: Soil K content (%), derived from fertility class of FAO
 Pe: Soil loss through erosion (t ha⁻¹ a⁻¹) per LUS (Land Use System; FAO)

The values of Nc, Pc and Kc used in the calculations are set to 0.1, 0.022, and 0.08 kg ha⁻¹, respectively. The

enrichment factor (EF) is set equal to 2 for N, P and K (Stoorvogel and Smaling, 1990a). From synthesis of work in Southern Mali, it has been derived that average losses through erosion in the cultivated zone are 7.41 t ha⁻¹ a⁻¹ (Kanté, 2001). In the calculations a value of 7 t ha⁻¹ a⁻¹ has been used.

Results and discussion

Analysis of the main production system in the study zone (cotton/cereals/animal husbandry) showed that certain flows were difficult to control, such as those of crop residues. The system is open, directly following harvest and exchange of forage and manure takes place between arable farms and their neighbours and with neighbouring regions.

Partial balances

Partial balances of cotton

Irrespective of village and farm type, in cotton, the driver of the system cotton/cereals/animal husbandry, the partial NPK-balances were positive (Table 2). For cash crops, because of the application of substantial quantities of manure, the balances were less negative than for food crops (Elias *et al.*, 1998; Van den Bosch *et al.*, 1998; Scoones and Toulmin, 1998, cited by Hilhorst *et al.*, 2000). The values for N and K were at least twice as high in M'Peresso as in Noyaradougou. That difference might be due to the fact that in M'Peresso more manure was used and cotton yields were lower than in Noyaradougou. In M'Peresso, where the pressure on the land was stronger, more than 50% of the inputs of nutrient elements originate from organic sources of which about half from household waste (Kanté, 2001). Organic nutrient sources were characterized by lower recoveries, i.e. smaller fractions taken up by the vegetation, than inorganic sources and consequently, the balances for the former were more favourable. It is also possible that the large doses of organic fertilizer only partially decomposed because of the small doses of mineral fertilizer applied, which might have led to immobilisation of nitrogen at the beginning of the growth cycle of cotton in M'Peresso, and thus to synchronisation problems (Sédogo, 1993; Tanner and Mugwira, 1984 cited by Murwira *et al.*, 1993).

In M'Peresso, potassium balances for class I farms were positive and higher than those for the other

Table 2. Partial balances of N, P, and K (in kg ha⁻¹ a⁻¹) for cotton in the villages of M'Peresso and Noyaradougou in Southern Mali (average of three years for M'Peresso and for 4 years for Noyaradougou)

Elements of partial balances	M'Peresso									Noyaradougou								
	Class I			Class II			Class III			Class I			Class II			Class III		
	N	P	K	N	P	K	N	P	K	N	P	K	N	P	K	N	P	K
Mineral fertilizer	36	10	11	44	13	13	37	9	10	10	50	14	15	13	14	51	14	15
Organic fertilizer (OF)	68	13	93	47	9.2	63	48	9.4	65	22	3.9	29	18	3.2	24	21	4.1	28
OF from animals	35	6	49	26	4.3	35.6	24.9	4	35	1.7	2.1	17.7	9.4	1.5	13.2	8	1.4	11
OF from household	33	7	44	20	4.6	27.5	21.7	4.9	29	8.6	1.7	11.6	7.8	1.5	10.6	12.5	2.5	17
OF from poultry	0	0	0	1	0.3	0.3	1.3	0.5	0.5	0.4	0.1	0.1	0.5	0.2	0.2	0.5	0.2	0.2
Total inputs	104	23	104	91	22.2	76	85	18.4	75	72	17.9	44	75	16.2	38	72	18.1	43
Grains and fibres	30	4	8	24	3	7	22	3	6	35	4	10	36	4	10	30	4	8
Residues	7	0.3	6	6	0.2	5	5	0.2	4	15	0.7	12	15	0.6	11	14	0.4	7
R of animals	6	0.3	5.4	4.5	0.2	4	3.9	0.2	3.5	8.9	0.5	7.9	5.3	0.3	4.7	6.2	0.2	3.3
R of household	0.9	0	0.8	0.8	0	0.7	1.0	0	0.9	4	0.2	3.5	6.5	0.3	5.8	3.4	0.2	3.0
R burned	0.3	0	0	0.4	0	0	0.4	0	0	1.5	0	0.1	3.2	0	0.3	4.6	0	0.4
Total exports	37	4.3	14	30	3.2	12	27	3.2	10	50	4.7	21	51	4.6	21	44	4.4	15
Balance	68	19	90	61	19	64	58	15	64	22	13	22	24	12	17	28	14	28

OF from animals: manure+droppings+direct manure in night corrals; OF of households: waste + compost; R of animals: residues utilised as forage, bedding and roadside grazing; R of household: residues utilised for garbage heaps, compost pits and potassium salts; NB: Residues left in the field and partially degraded by termites are considered 'neutral' for the system.

classes, while in Noyaradougou, the values for class III are slightly higher than those for the other classes. Farms of class I in M'Peresso utilised more organic fertilizers per unit area than classes II and III. Class III farms in Noyaradougou used practically the same quantities of fertiliser as the two other classes, but exported less.

In M'Peresso, exports in the form of cotton residues were limited and varied between 5 and 7 kg N ha⁻¹, 0.2 and 0.3 kg P and 4 and 6 kg K ha⁻¹, compared to imports in organic material varying between 47 and 68 kg N ha⁻¹, 9 and 13 kg P and 63 and 93 kg K (Table 2). A similar tendency was observed in Noyaradougou. Moreover, it was clear that cotton received organic inputs from elsewhere.

Partial farm balances of N, P and K

In addition to the principal crops (cotton, maize, sorghum, millet), peanuts, dolicos, cowpea, potatoes and vouandzou that were also grown, were taken into account in calculating farm nutrient balances. These balances showed that farm balances for nitrogen were positive in Noyaradougou, while they varied between 0.7 and -2.5 kg ha⁻¹ a⁻¹ in M'Peresso (Table 3). Irrespective of village and farm type, phosphorus balances were positive and varied between 2.9 and 6.5 kg ha⁻¹ a⁻¹. Partial potassium balances were negative for all classes, except for class III in Noyaradougou.

In terms of farm balances, there was no clear pattern among the classes. However, in Noyaradougou, the nitrogen balances increased from class I to class III, while the ratios IN/OUT (import/export) increased in the same direction. This implied that nitrogen was slightly better utilized in class I. This could be attributed to various reasons, such as the level of mechanisation or labour availability.

Partial balances of N, P and K were more negative in M'Peresso than in Noyaradougou. This might be due to the fact that in Noyaradougou the farming system was based on cotton-maize (76% of the area) which was fertilised, while in M'Peresso, these crops only occupied 42% of the area, compared to 48% for millet and sorghum. Millet and sorghum are generally not fertilised or receive only small doses and therefore these crops are considered substantial 'exporters' of nitrogen and especially of potassium. Therefore, at similar production levels, the balances at M'Peresso will be more negative than those at Noyaradougou. Actually, in Noyaradougou, 2.5 to 3 times (25 to 27 kg ha⁻¹ more nitrogen) as much mineral fertilizer was

used as in M'Peresso. However, in M'Peresso also 1.2 to 2 times as much organic fertilizer, equivalent to 2.7 to 12.3 kg ha⁻¹ more nitrogen was used than in Noyaradougou. The ratio IN1/IN2 (mineral fertilizer/organic fertilizer) for nitrogen varied between 0.7 and 1 in M'Peresso, while it varied between 3.4 and 3.7 in Noyaradougou. Such differences have an impact on soil characteristics. At higher rates of mineral nitrogen fertilizer and less organic fertilizer, soils may acidify with the consequence of lower yields. Applying more organic fertilizer of medium quality leads to immobilisation of nitrogen. The ratio of potassium exported by animals and organic fertilizer imported through animals (OUT2e/IN2e, Table 3) varied, irrespective of the village between 2 and 3. In other words, the animals exported 2 to 3 times more potassium than they imported into the system. To reduce the losses of nutrient elements, animal behaviour should be modified. On the other hand, recycling of crop residues through the household should be encouraged, because along this pathway imports exceed exports. This is due to the fact that crop residues are not the only inputs in household waste and composts.

Complete farm balances of N, P and K

Irrespective of village and farm type, the full nitrogen balances were negative. However, contrary to the partial balances, the full nitrogen balances in M'Peresso was more favourable than those in Noyaradougou (Table 4). This is mainly the result of the high mobility of nitrogen of which a proportion is lost through leaching and through gaseous losses, both from the soil and from the applied fertilizers. Leaching losses increased with increasing fertilizer doses. And the farms in Noyaradougou utilised more nitrogen than those in M'Peresso (Tables 3 and 4). Leaching was also influenced by soil fertility and rainfall. The soils cultivated in Noyaradougou with 0.03% nitrogen were relatively more fertile than those in M'Peresso that contained less than 0.02% (Kanté, 2001). Moreover, rainfall was higher in Noyaradougou (1000 mm) than in M'Peresso (800 mm). And, according to Van der Pol and Autissier (1997) a strong correlation exists between the magnitude of the balances and rainfall, that strongly affects the processes of erosion, leaching and also the export in crops ($N = -0.031 \cdot \text{annual rainfall (in mm)}, r^2 = 0.8$). Hence, nitrogen losses from indigenous soil nitrogen and from applied fertiliser were higher in Noyaradougou than in M'Peresso. The difference

Table 3. Partial balances of N, P and K (in kg ha⁻¹ a⁻¹) for farms in the villages of M¹Peresso and Noyaradougou in Southern Mali (average of three years)

Elements of partial balances	M ¹ Peresso									Noyaradougou								
	Class I			Class II			Class III			Class I			Class II			Class III		
	N	P	K	N	P	K	N	P	K	N	P	K	N	P	K	N	P	K
Mineral fertilizer	15.9	4.1	4.4	16.4	4.6	4.9	13.4	3.2	3.4	42.9	9.1	11.3	42.1	7.6	9.7	40.6	8	9.9
Organic fertilizer (OF)	23.8	4.6	32.7	16.4	3.2	22	14.5	2.9	19.4	11.5	2.1	15.7	8.1	1.5	11	11.8	2.2	15.9
OF from animals	12.0	1.9	16.8	9.7	1.7	13	8	1.4	10.6	6.97	1.2	9.5	4.5	0.8	6	4.8	0.9	6.4
OF from household	11.8	2.7	15.9	6.7	1.5	9	6.5	1.5	8.8	4.56	0.9	6.2	3.6	0.7	5	7.0	1.3	9.5
Total imports	39.8	8.7	37.1	32.8	7.8	26.9	27.9	6.0	22.8	54.5	11.2	27	50.2	9.1	20.7	52.4	10.2	25.8
Grains and fibres	21.6	2.5	5.4	18.8	2.2	4.8	17.3	2.0	4.2	28.2	3.7	7.3	24	3.1	5.8	22.6	2.9	5.4
Residues	19.4	1.6	50.3	13.3	1.1	33.2	13.1	1.1	35.7	17.4	1.3	23.8	15	1.1	22.6	17.3	0.8	17
R of animals	14.9	1.3	36.9	12	1.0	31.2	10.9	0.9	31.3	11.7	1.0	18.1	7.8	0.7	14.6	6.2	0.6	13.1
R of household	4.1	0.3	13.3	0.7	0.06	1.9	1.9	0.2	4.3	3.4	0.25	5.2	5	0.4	7.7	1.9	0.14	2.3
R burned	0.4	0.003	0.09	0.6	0.006	0.1	0.25	.002	0.06	2.3	0.02	0.5	2.2	0.02	0.3	9.2	0.09	1.6
Total exports	OUT1 + OUT2	40.9	4.1	55.7	32.1	3.3	38.1	30.4	40	45.5	5	31.1	39	4.2	28.4	39.9	3.7	22.4
Balance	IN-OUT	-0.3	4.7	-18.6	0.7	4.5	-11.2	-2.5	-17.2	9	6.2	-4.1	11.2	4.9	-7.7	12.5	6.6	3.4
R Incorporated		11.7	0.9	35	16.8	1.4	47.6	15.3	47.2	8.8	1	16.5	10	1.0	22.8	8.2	0.7	18

OF from animals: manure + droppings + direct manure in night corrals; OF from households: waste + compost; R of animals: residues utilised as forage, bedding and roadside grazing; R of household: residues utilised for garbage heaps, compost pits and potassium salts; R incorporated: residues left in the field, trampled by animals and partly degraded by termites and incorporated during tillage. That part is considered 'neutral' in the balance.

Table 4. Complete balances of N, P and K (in kg ha⁻¹ a⁻¹) for farms in the villages of M'Peresso and Noyaradougou in Southern Mali (average of three years)

Elements of complete balances	M'Peresso									Noyaradougou								
	Class I			Class II			Class III			Class I			Class II			Class III		
	N	P	K	N	P	K	N	P	K	N	P	K	N	P	K	N	P	K
Mineral fertilizer	15.9	4.1	4.4	16.4	4.6	4.9	13.4	3.2	3.4	42.9	9.1	11.3	42.1	7.6	9.7	40.6	8	9.9
Organic fertilizer	23.8	4.6	32.7	16.4	3.2	22	14.5	2.9	19.4	11.5	2.1	15.7	8.1	1.5	11	11.8	2.2	15.9
Atmospheric deposition	5.4	2.1	3.4	5.4	2.1	3.4	5.4	2.1	3.4	5.4	2.1	3.4	5.4	2.1	3.4	5.4	2.1	3.4
Biological input	5.8	-	-	5.5	-	-	5.9	-	-	5.3	-	-	5.1	-	-	5.4	-	-
Total inputs	51.0	10.8	40.5	43.7	9.8	30.3	39.2	8.2	26.2	65.2	13.3	30.4	60.7	11.2	24.1	63.2	12.3	29.2
Grains and fibres	21.6	2.5	5.4	18.8	2.2	4.8	17.3	2.0	4.2	28.2	3.7	7.3	24	3.1	5.8	22.6	2.9	5.4
Residues	19.4	1.6	50.3	13.3	1.1	33.3	13.1	1.1	35.7	17.3	1.3	23.8	15	1.1	22.6	17.3	0.8	17
Leaching losses	9.9	-	6.1	9.3	-	5	9	-	4.6	16.3	-	6.9	16	-	6.1	16.2	-	6.7
Gaseous losses	16.9	-	-	15.2	-	-	14	-	-	25.6	-	-	24.6	-	-	24.1	-	-
Erosion losses	14	2.8	11.2	14	2.8	11.2	14	2.8	11.2	14	2.8	11.2	14	2.8	11.2	14	2.8	11.2
Total exports	81.8	7	73	70.6	6	54.3	67.4	5.9	55.7	101.5	7.8	49.2	93.6	7	45.7	95.2	6.5	40.3
Balance	-30.8	3.8	-32.5	-26.9	3.8	-24	-28.2	2.3	-29.5	-36.3	5.5	-18.8	-32.9	4.2	-21.6	-32	5.8	-11.1
R Incorporated	11.7	0.9	35	16.8	1.4	47.6	15.3	1.2	47.2	8.8	1	16.5	10	1.0	22.8	8.2	0.7	18

R incorporated: residues left in the field, trampled by animals and partly degraded by termites and incorporated during tillage. That part is considered 'neutral' in the balance.

between the balances (both partial and complete) varied between 26 and 30 kg N ha⁻¹ in M'Peresso and between 43 and 46 kg N ha⁻¹ in Noyaradougou. However, the differences between the two villages could be smaller when the texture of the soils was taken into account, as the soils were sandier in M'Peresso than in Noyaradougou. Irrespective of the village, the nitrogen balance was more negative for class I farms than for the other two classes. In fact, the class I farms used relatively more nitrogen than the other two, but also exported more in crops and were characterized by higher non-productive losses.

Taking into account that the soils in M'Peresso and Noyaradougou contained 800 and 1200 kg N ha⁻¹, respectively (**Qn**), i.e. 0.02 and 0.03% and that the nitrogen balances are -28.6 and -33.7 kg ha⁻¹ a⁻¹ in the two villages (Kanté, 2001), annual losses (**I**) were 3.6% in M'Peresso and 2.8% in Noyaradougou. Hence, the residual nitrogen stock after one year (**Nr**) was 96.4 and 97.2%, respectively in M'Peresso and Noyaradougou. The residual quantity of nitrogen (**Qa**) after 20 years (**n**) can be calculated according to Smaling (1993b) as: $Qa = Qn * (1 - I/100)^n$. Thus after 20 years continuous cultivation under current management practices, residual nitrogen will be 48 and 56% of the original stock in M'Peresso and Noyaradougou, respectively. This change will no doubt be accompanied by a substantial yield decline.

The full balances of phosphorus showed the same tendencies as the partial balances: they were positive in both villages and for all farm types. As for the partial balances, the values were higher in Noyaradougou than in M'Peresso. The differences between the partial and complete balances were only about 0.7 kg ha⁻¹. This is associated with the limited mobility of phosphorus and the relatively small quantities exported in crop material, compared to N and K. The positive P-balances, or in other words the build-up of P-stocks, resulted in increasing nitrogen utilization efficiencies, while P-fertiliser application at a rate of 1.1 times the exported quantities might result in gradually declining P-availability and hence lower yields (Breman, 1998).

The complete potassium balances, as those of nitrogen, were negative for both villages and for all farm types (Table 4). As for the partial balances, the deficits were smaller in Noyaradougou than in M'Peresso. This might be associated with the differences in farming systems. In fact, in the residues of millet and sorghum had 1.5–4 times more potassium exported than that exported in maize (Kanté, 2001). The differences in potassium balances were around 10–14 kg ha⁻¹.

Hence, the partial balances in general showed a more positive picture than the complete balances. The differences between the two types of balances were affected by the mobility of the elements and were thus largest for nitrogen, followed by potassium and finally phosphorus. The observed values were close to those found in other studies in Southern Mali (Van der Pol, 1993; Smaling, 1993a), and would have been even closer if the fallows had been taken into account.

Conclusions

Cotton receives by far the largest share of the fertilizers and its nutrient balances are therefore the most favourable in the farming system cotton/cereals/animal husbandry. The partial nutrient balances of the various farm types were not significantly different. For nitrogen, the balances were positive to slightly negative. For phosphorus, it was positive and for potassium in general, negative. For K, the deficits were more pronounced for the systems based on cotton-millet and cotton-sorghum than for those on cotton-maize. The complete farm balances were negative for nitrogen and potassium for all farm types, while for phosphorus they remained positive. In both villages, the nitrogen balance was more negative for class I farms than for the other two farm types. The relative annual decline in soil nitrogen stock was about 3.6 and 2.8% respectively, in M'Peresso and Noyaradougou. This implies that under current management practices, only 48 and 56% of the nitrogen stock would remain after another 20 years. Hence, efforts should be made to increase inputs of external nutrients in the farming system, and at the same time to reduce non-productive losses. The differences between the partial balances and complete balances for the different nutrients depend on their mobility and were largest for nitrogen, followed by potassium and phosphorus.

Acknowledgments

The authors thank Robert Berthé, Toon Defoer, Ibrahim Dembelé, Lassine Dembelé, Loes Kater and Moumine Traoré for their contribution to collection, analysis and organisation of the data. They also thank the Directorate General for International Cooperation (DGIS) of the Dutch Ministry of Foreign Affairs for their financial support for the first author.

References

- Breman H. 1998. Amélioration de la fertilité des sols en Afrique de l'ouest: Contraintes et perspectives. In: Renard G., Neef A., Becker K. and von Oppen M. (Eds) Soil fertility management in West African land use systems. Gestion de la fertilité des sols dans les systèmes d'exploitation d'Afrique de l'Ouest. Proceedings of regional workshop, University of Hohenheim, ICRISAT Sahelian Center and INRAN, Niamey, Niger, 4–8 March 1997, pp. 7–20.
- Camara O.S. 1996. Utilisation des résidus de récolte et du fumier dans le Cercle de Koutiala: Bilan des éléments nutritifs et analyse économique. Rapports PSS No. 18, Wageningen, AB-DLO, 120 p.
- Cretenet M. 1996. Expérimentation des systèmes de culture dans les pays tropicaux: cas des zones cotonnières d'Afrique noire. In: Budelman A. (Ed.) Agricultural R&D at the crossroads. Merging systems research and social actor approaches. Royal Tropical Institute (KIT), the Netherlands, pp. 69–80.
- Elias E., Morse S. and Belshaw D.G.R. 1998. Nitrogen and phosphorus balances of Kindo Koisha farms in southern Ethiopia. *Agric., Ecosyst. Env.* 71: 93–113.
- Hilhorst T., Muchena F., Defoer T., Hassink J., De Jager A., Smaling E. and Toulmin C. 2000. Managing soil fertility in Africa: diverse settings and changing practice. In: Hilhorst T. and F. Muchena (Eds). Nutrients on the move. Soil fertility dynamics in African farming systems, Nottingham, UK, pp. 1–27.
- IER/CMDT 1987. Dégradation chimique des sols et possibilités d'amélioration. Document N° 3, Réunion IER – CMDT, 10–12 février, N°Tarla, 44 p.
- Kanté S. 2001. Gestion de la fertilité des sols par classe d'exploitation au Mali-Sud. PhD Thesis, Wageningen University, Wageningen, The Netherlands, 236 p.
- Murwira K.H., Swift M.J. and Frost P.G.H. 1993. Manure as a key resource in sustainable agriculture. In: Powell J.M., Fernandez-Rivera S., Williams T.O. and Renard C. (Eds) Livestock and Sustainable Nutrient Cycling in Mixed Farming Systems of sub-Saharan Africa. Proceedings of an International Conference, International Livestock Centre for Africa (ILCA), Addis Ababa, Ethiopia, 22–26 November 1993, Volume II, pp. 131–148.
- Nidoumbe F.M. and Van der Pol F. 1999. Integrated Environmental and Economic Accounting: Incorporating soil nutrient depletion in conventional farm accounts. Working Document (Draft 10), Royal Tropical Institute (KIT), 84 p.
- Ramisch J. 1999. In the balance? Evaluating soil nutrient budgets for an agro-pastoral village of Southern Mali. *Managing Africa's soils* N° 9, IIED, London, UK, 28 p.
- Schrader T.H. and Wennik B.H. 1996. La lutte anti-érosive en zone CMDT. Rapport final du projet LAE, Compagnie Malienne pour le Développement des Textiles (CMDT), Institut Royal des Tropiques (KIT), Amsterdam, the Netherlands, 66 p.
- Scoones I. and Toulmin C. 1998. Soil nutrient balances: what use for policy? *Agric., Ecosyst. Env.* 71: 255–267.
- Sédogo M.P. 1993. Evolution des sols ferrugineux lessivés sous culture: Incidence des modes de gestion sur la fertilité. Thèse Doctorat es sciences, Université Nationale de Côte d'Ivoire, Abidjan, 343 p.
- Smaling E.M.A. 1993a. Appauvrissement du sol en nutriment de l'Afrique Subsaharienne. In: Van Reuler H. and Prins W.H. (Eds) Rôle de la fertilisation pour assurer une production durable des cultures vivrières en Afrique Subsaharienne. VKP, Leiden, pp. 59–75.
- Smaling E.M.A. 1993b. An agro-écological framework for integrated nutrient management with special reference to Kenya. PhD Thesis, Wageningen Agricultural University, Wageningen, The Netherlands, 250 p.
- Smaling E.M.A., Fresco L.O. and De Jager A. 1996. Classifying, monitoring and improving soil nutrient stocks and flows in African agriculture. *Ambio* 25: 492–496.
- Stoorvogel J.J. and Smaling E.M.A. 1990a. Assessment of soil nutrient depletion in Sub-Saharan Africa: 1983–2000. Volume I: Main report (second edition), Staring Centrum (SC-DLO), Report 28, Wageningen, The Netherlands, 137 p.
- Stoorvogel J.J. and Smaling E.M.A. 1990b. Assessment of soil nutrient depletion in Sub-Saharan Africa: 1983–2000. Volume III: Literature review and description of Land Use Systems, Staring Centrum (SC-DLO), Report 28, Wageningen, The Netherlands, 162 p.
- Van den Bosch H., Gitari J.N., Ogaro V.N., Maobe S. and Vlaming J. 1998. Monitoring nutrient flows and economic performance in African farming systems (NUTMON). Monitoring nutrient flows and balances in three districts in Kenya. *Agric., Ecosyst. Env.* 71: 63–80.
- Van der Pol F. 1992. Soil mining: An unseen contributor to farm income in southern Mali. Bulletin 325, Royal Tropical Institute (KIT), Amsterdam.
- Van der Pol F. 1993. Analyse et évaluation des options pour une agriculture durable, cas particulier du Sud Mali. In: Van Reuler H. and Prins W.H. (Eds) Rôle de la fertilisation pour assurer une production durable des cultures vivrières en Afrique Subsaharienne. VKP, Leiden, pp. 77–98.
- Van der Pol F. and Autissier V. 1997. La valeur de l'épuisement des sols par l'agriculture dans les pays du CILSS. Rapport préliminaire, Club du Sahel, Ouagadougou, Burkina Faso, 33 p.

Increasing the Productivity and Sustainability of Millet Based Cropping Systems in the Sahelian Zones of West Africa

Traoré Samba¹, Birama S. Coulibaly², Amadou Koné, Minamba Bagayoko³ and Zoumana Kouyaté

¹Cinzana Agricultural Research Station, PO Box 234, SEGOU Rep. of Mali, E mail: samba.traore@ier.ml; **Corresponding author.** Tel: (223) 2 32 04 86; ²Cinzana Agricultural Research Station, BP 214 SEGOU. Rep. of Mali; ³Coordinator of Irrigated System Pool in Mali.

Abstract

A study was set up in Mali during four consecutive years to evaluate the effect of three cowpea plant populations on the performance of three pearl millet genotypes in intercropping and in rotation with cowpea. The trial was conducted on a leached tropical sandy soil at the Cinzana Agricultural Research Station at 300 km from Bamako. Pearl millet genotypes used in the test were: Indiana 05, Sanioba 03 and Toroniou C1. The cowpea genotype was evaluated at 16600, 33300 and 66600 plants ha⁻¹ corresponding respectively to low, medium and high plant populations. Alternate rows of millet and cowpea were used in intercropping. The rotation started from the second year.

The three pearl millet genotypes had similar grain yield, panicle production, plant height, and plant population at harvest except in 2001 (the driest year) in which Toroniou had the highest yields. The analysis of the highly significant genotype by cowpea density interaction observed in 2003 indicates that Indiana 05, Sanioba 03 and Toroniou C1 had respectively the highest straw yield at medium, high and low cowpea plant populations. The reason for this differential response of pearl millet genotypes to cowpea plant population is not well understood and may be due to differences in plant architecture.

Pearl millet had a greater performance in intercropping than in monoculture. This land saving technology contributes largely to improve crop productivity and sustainability by improving the use of local resources and could contribute to reducing human pressure on land and natural resources

Key words: Cropping systems, Crop rotation, genotypes, Growth stages, Land Equivalent Ratio, Intercropping, Land saving technology, Monoculture, Plant populations, Sustainability

Introduction

In the Sahelian zones of West Africa, poor agricultural land and crop management techniques combined with high input costs relative to those of rain fed cereal crops constitute the major factors contributing to continuous soil degradation and fertility depletion. Soil fertility depletion in smallholder farms is considered as one of the fundamental biophysical root causes for declining per capita food production in sub-Saharan Africa (Sanchez et al., 1997).

Pearl millet (*Pennisetum glaucum* (L.) R. Br.) is a major staple food source for millions of people in the Sahelian countries of West Africa. Among the different constraints relative to its production, low soil fertility is one of the most important factors limiting millet yield. Efforts to enhance agricultural production and productivity involve changes in the components of agricultural systems. Genotype and management changes leading to higher levels of crop productivity and stability enable design and development of profitable cropping systems. The efficacy of chemical fertilizers on crop

production is obvious and does not need any more demonstration. However, the inadequacies between the price of chemical fertilizers and that of rain fed crops such as millet and sorghum do not favor the application of recommended rates of mineral fertilizers on these crops.

In crop rotation studies, the use of leguminous crops such as cowpea and peanut in the cropping systems contributes to improve soil nitrogen status compare to that of millet in monoculture. In fact, studies conducted in Niger indicated a greater pearl millet yield improvement in rotation with cowpea or groundnut compare to monoculture of millet (Bationo, 1995). In Mali, long term studies on cropping systems conducted at Cinzana Agricultural Research Station, also indicated a greater contribution to pearl millet yield improvement compared to the application of 40 N ha^{-1} on millet in monoculture (Bagayoko et al., 1996; Bagayoko, 1999). Studies conducted in Nigeria indicated residual effects of cowpea on the succeeding pearl millet yield equivalent to the addition of 36 kg N ha^{-1} (Eaglesham et al., 1982).

The use of pearl millet and cowpea in rotation combined with recommended doses of organic and mineral fertilizers constitutes alternative ways of sustainable soil fertility management contributing to improved crop productivity. The positive effect of crop rotation is attributed to nitrogen fixed by leguminous crops in the system (Bationo, 1995). However, other researchers have attributed positive effects associated with crop rotation to improved soil physical and chemical properties and the capacity of some leguminous crops to solubilize the phosphorus linked to calcium through root exudates (Bationo, 1995).

Poor soil management and high input prices are some of the most important factors responsible for continuous soil degradation in the sahelian zones of West Africa contributing to a rapid soil depletion in nutrients and a decrease in crop productivity (Breman, 1987; Piéri Christian, 1992; Smaling, 1993; Smaling et al., 1996; Sanchez et al., 1997; FAO, 1999). The monoculture and the lack of restitution of crop residues contribute to increase soil acidification leading to significant decrease in soil exchangeable bases. Similar results were obtained under the application of chemical fertilizer without organic amendment (Bagayoko et al., 1996; Bationo, 1997a,b; Coulibaly et al., 1998). Poor soil management in many farmer's fields leads to continuous decrease in soil organic matter content below 0.6% necessary for soil protection against soil erosion (Piéri, 1988). Soil erosion contributes to the loss of 10 to 60% of soil nutrients in Mali (Kieft et al., 1994).

Combining crop rotation with pearl millet and cowpea intercropping is a new approach to increased crop productivity and sustainability. A study was therefore set up at Cinzana Agricultural Research Station to evaluate the effect of three cowpea plant populations on the performance of three pearl millet genotypes in intercropping and in rotation with cowpea.

The study evaluated the effect of genotype and cowpea plant populations on the growth and yield of pearl millet in intercropping and in rotation with cowpea.

Material and methods

The trial was conducted on a leached tropical sandy soil at the Cinzana Agricultural Research Station at 300 km from Bamako. Pearl millet genotypes used in the test were: Indian 05, Sanioba 03 and Toroniou C1. Indiana 05 and Sanioba 03 are fully sensitive to day length. Toroniou is slightly sensitive to day length.

The cowpea genotype used was IT-89KD-245. It was evaluated in the test at three different plant populations as follows: a low plant population of 16600 plants ha^{-1} in witch cowpea was planted at 1.5m x 0.8m thinned to 2 plants per hill; a medium plant population of 33300 plants ha^{-1} in witch cowpea was planted at 1.5m x 0.4m and thinned to 2 plants per hill; a high plant population of 66600 plants ha^{-1} in witch cowpea was planted at 1.5m x 0.2m and thinned to 2 plants per hill.

The intercropping strategy used in the experiment was alternate rows of millet and cowpea. Pearl millet and cowpea were planted on 0.75 m spaced ridges. Pearl millet was planted in sole crop at a spacing of $0.75\text{m} \times 0.80\text{m}$ thinned at 2 plants per hill or 33000 plants ha^{-1} . In intercropping, it was planted at $1.50 \text{ m} \times 0.40 \text{ m}$ spacing or 33000 plants ha^{-1} . Cowpea was planted at three different plant populations thinned at 2 plants ha^{-1} as indicated above. The experiment started the first year by the intercropping of millet and cowpea. Crop rotation started the second year by replacing pearl millet rows with cowpea rows and vice versa. All the treatments received 50 kg ha^{-1} of Di-Ammonium Phosphate (DAP). The first weeding was realized 15 days after emergence, while the second weeding was realized 3 weeks after the first one.

Plants were sampled at different phenological growth stages. Four millet plants and four cowpea plants were cut at the ground level to reduce border effect. Millet plant height was measured prior to cutting. Plant samples were reduced in small pieces and air dried to obtain plant dried weight. Soil samples were

also taken at a depth of 0 to 25 cm at the beginning of the experiment and analyzed for initial nutrient contents. Other soils analyses are planned after two cycles of rotation to evaluate soil fertility status.

Field observations included plant height and dry weight accumulation at different phenological growth stages (Tillering, Elongation, Flowering and Physiological maturity), yield and yield components.

The experiment was a 3×3 factorial in a Randomized Complete Bloc Design with 3 replications. The two factors evaluated were pearl millet genotypes and cowpea plant populations. Each factor had three levels as described above. The experimental unit had 10 rows of millet in monoculture or 5 rows of millet and 5 rows of cowpea in intercropping of 10 meters length or 75 m^2 . The harvested area in intercropping was composed of 2 rows of millet and 2 rows of cowpea on 8 meters length or 24 m^2 . In sole crop, the harvested area was 4 rows of 8 meters length or 24 m^2 . Six additional sole crops representing the 3 millet genotypes and the 3 cowpea densities were included in the experiment to allow the computation of Land equivalent ratios for both species. Land equivalent ratio for pearl millet and cowpea was calculated as follow:

$$LER = \frac{\text{Yield of millet in int ercropping}}{\text{Yield of millet in monoculture}} (1) + \frac{\text{Yield of cowpea in int ercropping}}{\text{Yield of cowpea in monoculture}} (2)$$

If $LER = 1$ Means equality between intercropping and monoculture

If $LER > 1$ Means more advantage due to intercropping

If $LER < 1$ Means less performing than monoculture of the species

Components (1) and (2) are called partial LERS for millet and cowpea respectively.

The analysis of variance was performed as statistical tool for investigation. Least significant difference (LSD at 0.05) was used to compare treatment means.

Results and discussions

Pearl millet grain yield

Pearl millet grain yield is presented in Table 1. No significant genotype by cowpea plant population

interaction was observed on pearl millet grain yield ($Pr \geq 0.05$). The three pearl millet genotypes had similar grain yield except in 2001. During that year witch was exceptionally dry, Toroniou had the highest yield compared to the other two genotypes ($Pr < 0.05$). The plant population effect was not significant on pearl millet yield. This indicates that the different genotypes responded similarly to different cowpea densities. Among the four years, the lowest pearl millet yields were obtained in 2001. The combined analysis did not indicate any significant year by treatment interaction. However there was a highly significant year effect on pearl millet grain yield. The highest grain yields were obtained under sufficient rainfall conditions. Grain yields obtained during four consecutive years with one of the most popular genotype (Toroniou) is represented in Figure 1. Pearl millet yielded more in intercropping than in monoculture. Similar results were obtained in long term studies conducted at Cinzana Agricultural Research Station on cropping systems. In these studies, pearl millet yield obtained in rotation with cowpea was equivalent to that obtained using 40 N ha^{-1} in monoculture (Bagayoko et al., 1996, 1999). Results obtained on millet from a rotation study with cowpea based on the use of Tilemsi rock phosphate applied to cowpea indicated that pearl millet yield of 1200 kg ha^{-1} can be easily obtained the following year without any application of fertilizer. These results are attributed to the combined residual effects of the rock phosphate and nitrogen fixed by cowpea the previous year. The positive effect of crop rotation has been attributed to nitrogen fixed by leguminous crops in the system (Bationo, 1995). However, other researchers have attributed positive effects associated with crop rotation to improved soil physical and biological properties and the capacity of some leguminous crops to solubilize the phosphorus linked to calcium through root exudates. This new system of rotation based essentially on the use of rock phosphate minimizes the cost of production of millet and could contribute to increased crop productivity and sustainability for smallholders in the sahelian zones of West Africa.

Pearl millet panicle yield

Pearl millet head yield is presented in Table 2. No significant genotype by cowpea plant population interaction was observed on pearl millet head yield ($Pr \geq 0.05$). The three pearl millet genotypes had similar head

Table 1. Effects of pearl millet genotypes and cowpea plant populations on millet grain yield, Cinzana 2000–2002

Treatments	Grain yield (kg ha ⁻¹)				Average yield (kg ha ⁻¹)
	2000	2001	2002	2003	
Genotypes					
1. India na 05	1407	686	1600	1463	1289
2. Sanioba 03	1344	533	1479	1384	1185
3. Toroniou C1	1525	862	1606	1488	1370
Plant population					
1. (16600 plants/ha)	1516	649	1613	1350	1282
2. (33300/ha)	1449	755	1579	1454	1309
3. (66600 plants/ha)	1312	677	1493	1488	1243
ES±	86	57	136	78	47
Genotypes	NS	HS	NS	NS	NS
Plant population	NS	NS	NS	NS	NS
Genotypes × plant population	NS	NS	NS	NS	NS
C.V (%)	18	25	26	16	22

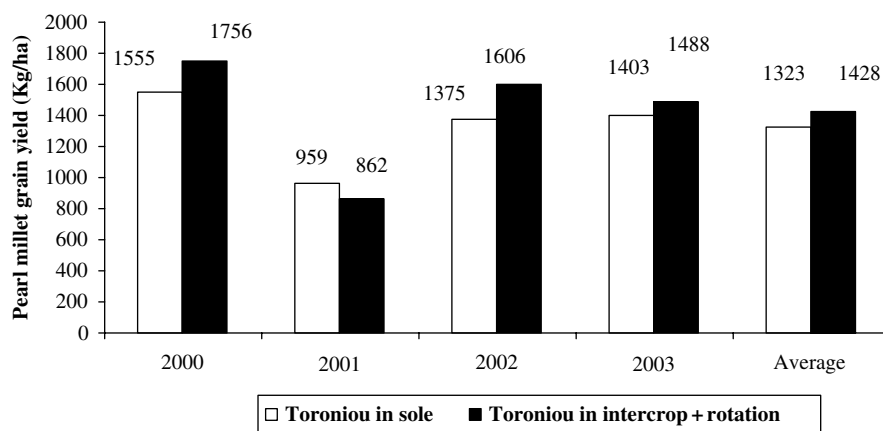

Figure 1. Pearl millet grain yield (kg ha⁻¹) in sole and in intercropping and rotation with cowpea.

yield during the four years. The plant population effect was not significant on pearl millet head yield. This indicates that the different genotypes responded similarly to different cowpea densities. The drought observed in 2001 had a negative impact on pearl millet head yield. In fact, among the four years, the lowest pearl millet head yields were obtained in 2001. The combined analysis did not indicate any significant year by treatment interaction on pearl millet head weight. However there was a highly significant year effect on pearl millet head yield (results not shown). The highest head yields were obtained under sufficient rainfall situations.

Pearl millet straw yield

Pearl millet straw yield is presented in Table 3. A highly significant genotype by cowpea plant population interaction was observed only in 2003 ($Pr \geq 0.01$). The analysis of this interaction indicates that the yield of the three genotypes was differently affected by cowpea plant population. Indiana had the highest straw yield at the medium cowpea density. Sanioba produced more straw when it was intercropped with the highest cowpea plant population. Toroniou produced more straw at the lowest cowpea density. The reason for this differential response of pearl millet genotypes to

Table 2. Effects of pearl millet genotypes and cowpea plant populations on millet head yield, Cinzana 2000–2003

Treatments	Head yield (kg ha ⁻¹)				Average yield (kg ha ⁻¹)
	2000	2001	2002	2003	
Genotypes					
1. India na 05	2104	1162	2296	2060	1906
2. Sanioba 03	1962	1014	2088	1917	1745
3. Toroniou C1	2090	1329	2294	1956	1917
Plant population					
1. (16600 plants/ha)	2150	1190	2252	1870	1866
2. (33300/ha)	2081	1157	2245	2014	1874
3. (66600 plants/ha)	1921	1157	2181	2049	1827
ES±	122	76	167	103	66
Genotypes	NS	NS	NS	NS	NS
Plant population	NS	NS	NS	NS	NS
Genotypes x plant population	NS	NS	NS	NS	NS
C.V (%)	18	20	22	15	21

Table 3. Effects of pearl millet genotypes and cowpea plant populations on millet straw yield, Cinzana 2000–2003

Treatments	Straw yield (kg ha ⁻¹)				Average yield (kg ha ⁻¹)
	2000	2001	2002	2003	
Genotypes					
1. India na 05	3842	2986	3403	2639	3218
2. Sanioba 03	4143	2789	3380	3079	3348
3. Toroniou C1	4282	3102	3565	2824	3443
Plant population					
1. (16600 plants/ha)	4004	2870	3403	2639	3229
2. (33300/ha)	4282	3148	3519	2801	3438
3. (66600 plants/ha)	3981	2859	3426	3102	3342
ES±	402	226	205	126	129
Genotypes	NS	NS	NS	NS	NS
Plant population	NS	NS	NS	NS	NS
Genotypes × plant population	NS	NS	NS	HS	NS
C.V (%)	29	23	18	13	23

cowpea plant population is not well understood. The drought observed in 2001 had a negative impact on pearl millet straw yield. In fact, among the four years, the lowest pearl millet straw yields were obtained in 2001 (Table 3). The combined analysis did not indicate any significant year by treatment interaction on pearl millet straw weight. However there was a highly significant year effect on pearl millet straw yield (results not shown). The highest straw yields were obtained under sufficient rainfall situations in 2000, 2002 and 2003.

Pearl millet plant height

Pearl millet plant height is presented in Table 4. No significant genotype by cowpea plant population interaction was observed on pearl millet plant height ($Pr \geq 0.05$). The three pearl millet genotypes had similar plant height except in 2003 where Sanioba 03 had the highest plant height compared to the other two genotypes. The plant population effect was not significant on pearl millet height. This indicates that the different genotypes responded similarly to different

Table 4. Effects of pearl millet genotypes and cowpea plant populations on millet height, Cinzana 2000–2002

Treatments	Plant height (cm)				Average height (cm)
	2000	2001	2002	2003	
Genotypes					
1. India na 05	251	268	301	312	283
2. Sanioba 03	251	256	301	329	284
3. Toroniou C1	252	258	296	310	279
Plant population					
1. (16600 plants/ha)	246	259	293	315	278
2. (33300/ha)	255	260	310	316	285
3. (66600 plants/ha)	253	263	296	321	283
ES±	5	8	5	4	3
Genotypes	NS	NS	NS	S	NS
Plant population	NS	NS	NS	NS	NS
Genotypes × plant population	NS	NS	NS	NS	NS
C.V (%)	6	9	5	4	6

cowpea densities. The combined analysis did not indicate any significant year by treatment interaction. However there was a highly significant year effect on pearl millet plant height. The highest plant heights were obtained under sufficient rainfall situations in 2003 and 2002.

Plant height development over time by pearl millet

Results obtained on plant height measurements at different phenological growth stages are presented in Table 5. No significant genotype by cowpea plant

population interaction was observed on pearl millet plant height. The effect of genotype was significant at the first two growth stages. Toroniou had a greater plant height at tillering and elongation stages compared to the two other genotypes (Figure 1). Higher height development could result in greater competitive ability with weeds through the effect of shading. Among the local genotypes, it was the first time that a fastest growing genotype was identified in our breeding material. Cowpea plant population effect was significant towards the end of the growing season. The highest cowpea plant population resulted in the highest plant height at flowering.

Table 5. Effects of pearl millet genotypes and cowpea plant populations on millet height development at different phenological growth stages, Cinzana 2000

Treatments	Plant height (cm) at different growth stages			
	Tillering	Elongation	Flowering	Physiological maturity
Genotypes				
1. Indiana 05	22	134	193	251
2. Sanioba 03	24	127	201	251
3. Toroniou C1	27	161	222	252
Plant population				
1. (16600 plants/ha)	24	139	180	246
2. (33300/ha)	24	143	219	255
3. (66600 plants/ha)	25	139	216	253
ES±	1	6	9	5
Genotypes	S	HS	NS	NS
Plant population	NS	NS	S	NS
Genotypes × plt population	NS	NS	NS	NS
C.V (%)	16	12	13	6

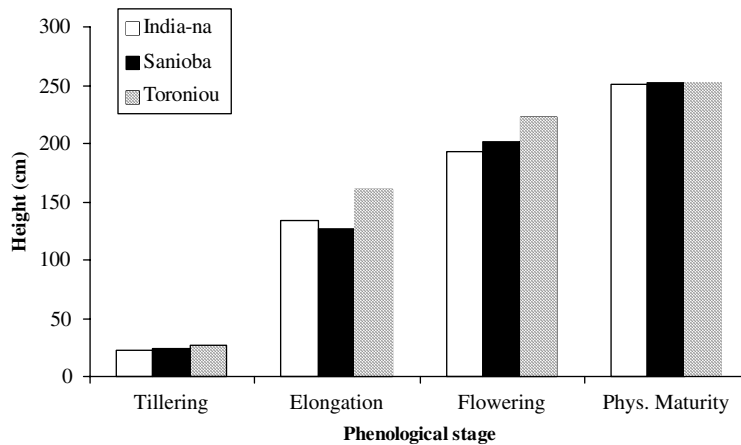

Figure 2. Pearl millet plant height development at four phenological growth stages, Cinzana Agricultural Research Station, 2000.

Pearl millet plant population at harvest

Pearl millet plant population at harvest is presented in Table 6. No significant genotype by cowpea plant population interaction was observed on plant population at harvest ($Pr = 0.05$). No genotype or cowpea plant density effect was observed for pearl millet plant population at harvest. These results indicate that the three genotypes responded similarly to cowpea plant population effects. The combined analysis did not indicate any significant year by treatment interaction on pearl millet plant population at harvest. However there was a highly significant year effect on pearl millet plant population (results not shown). The highest plant populations were obtained under sufficient rainfall conditions in 2002 and 2003.

Performance of intercropping systems.

Land equivalent ratios (LER) of pearl millet grain production for the three genotypes are presented in Figure 3. Partial LER for grain for the three genotypes were all greater than 1. Partial LER greater than 1 indicates greater performance of millet in intercropping than in monoculture. Toroniou for example produced 1600 kg ha^{-1} in intercropping against 1375 kg ha^{-1} in monoculture. This land saving technology contributes largely to improve crop productivity. The good performance of Toroniou could be attributed to a better use of local resources. In fact, good soil cover provided by cowpea in the system contributes to reduce soil evaporation. Alternate rows of millet and cowpea also favour the penetration of light into the canopy and

Table 6. Effects of pearl millet genotypes and cowpea plant populations on the number of plants at harvest, Cinzana 2000–2002

Treatments	Number of plants/ha				Average Number of plants/ha
	2000	2001	2002	2003	
Genotypes					
1. Indiana 05	33925	33565	49815	40324	42824
2. Sanioba 03	34311	38287	53796	39954	48704
3. Toroniou C1	33400	40602	57593	39954	49178
Plant population					
1. (16600 plants/ha)	34251	34454	52639	38426	46285
2. (33300/ha)	34192	39028	55228	40556	47546
3. (66600 plants/ha)	34192	35972	53287	41250	46875
ES±	253	2447	2316	1504	1092
Genotypes	NS	NS	NS	NS	HS
Plant population	NS	NS	NS	NS	NS
Genotypes × plant population	NS	NS	NS	NS	NS
C.V (%)	2	19	13	11	14

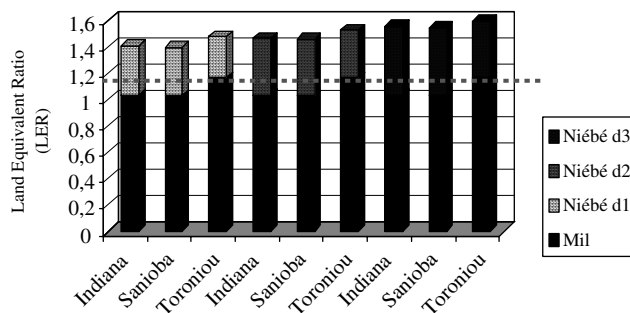

Figure 3. Land Equivalent Ratios (LER) evaluated using pearl millet and cowpea grain production. Cowpea plant population used were d1 = 16600 plants/ha, d2 = 33300 plants/ha and d3 = 66600 plants/ha.

may improve the rate of photosynthesis for basal leaves at least for pearl millet in the system. In addition, the leguminous contributes to improve the nitrogen status of the soil. Finally the differential rooting system of pearl millet and cowpea may contribute to reduce the inter-specific competition for nutrients.

Conclusions

Results of the study indicated a greater performance of Toroniou in intercropping than the other genotypes. Intercropping of pearl millet and cowpea in the study was more productive than the monoculture of pearl millet for four consecutive years. This important land saving technology will increase crop productivity and sustainability by improving the use of local resources and by reducing human pressure on land and natural resources.

References

- Bagayoko M.S., Mason C., Traoré S. and Eikert K.M. 1996. Pearl millet/cowpea cropping system yield and soil nutrient levels. *African crop science journal* 4 (4): 453–462.
- Bagayoko M. 1999. Site-Specific Effects of Cereal/Legume Rotations in West Africa: Soil Mineral Nitrogen, Mycorrhizae and Nematodes. In Verlag Grauer (ed.), Stuttgart, 1999. ISBN 3-86186-284-0
- Bationo A. 1995. Gestion des éléments nutritifs dans la zone soudano-sahélienne d’Afrique de l’Ouest. In *Rapport Annuel 1995*. pp. 36–42.
- Bationo A., Lompo F., Koala S., Nandwa S. and Bekunda M. 1997a. Nutrient balance studies and available technologies to combat land degradation in Africa. IFDC I ICRISAT.
- Bationo A., Biélers C.L., Buerkert A.C., Seyni F. and van Duivenboden N. 1997b. A global review of research highlights on the management of nutrient and water in the west African semi- arid tropics. IFDC I ICRISAT.
- Bremner H. 1987. Planification de la recherche de la DRSPR. Contribution aux discussion pour le programme de la campagne 1988/1989. Note interne. Sikasso, Mali : DRSPR.
- Coulibaly A., Bagoyoko M., Traoré S. and Mason S.C. 1998. Crop residue management and system influence on pearl millet and cowpea yield. INTSORMIL grant. Contribution of IER and University of Nebraska, Lincoln, NE.
- Eaglesham A.R.J., Ayanaba A., Rao V.R. and Eskew D.L. 1982. Mineral N effects in cowpea and soybean crops on a Nigerian soil. II. Amounts of N fixed and added to the soil. *Plant and Soil* 68: 183–192.
- FAO 1999. Soil fertility initiative, Sub-Saharan Africa. http://www.fao.org/Waicent/faoinfo/agricult/AGL/agln/p_sfi.htm 18 February 1999.
- Kieft H., Keita N. and van der Heide A. 1994 : Engrais fertiles ? Vers une fertilité durable des terres agricoles au Mali, 99 p. ETC, Leusden, the Netherlands
- Piéri. C. 1988. Fertilité des terres de savanes: Bilan de trente ans de recherche et de développement agricoles au sud du Sahara. Ministère de la coopération, CIRAD-IRAT.
- Piéri Christian J.M.G. 1992. Fertility of soils. A future for farming in the west African Savannah, Springer-Verlag.
- Rapport Annuel du projet Mise au Point des Techniques de Restauration et d’Amélioration de la Fertilité des Sols dans les Zones Sahélienne et Soudanienne du Mali, 2000, 2001, 2002.
- Sanchez, P.A., K.D. Shepherd, M.J. Soule, F.M. Place, R.J. Buresh, and A.M.N Izac. 1997. Soil fertility replenishment in Africa: An investment in natural resource capital. In: *Replenishing Soil fertility in Africa*. SSSA Special Publication Number 51: 1–46.
- Smaling E.M.A. 1993. An Agro-ecological framework for integrated nutrient management, with special reference to Kenya. Ph.D. dissertation, Agricultural University, Wageningen, The Netherlands.
- Smaling E.M.A., Nandwa S.M. and Janssen B.H. 1996. Soil fertility in Africa is at stake. In: *Replenishing Soil Fertility in Africa*. SSSA Special Publication Number 51: 47–61.
- Traoré Samba et al., 2000. Etude de la performance de trois génotypes de mil (*Pennisetum glaucum*) en association avec un niébé (*Vigna unguiculata*) “résistant” au *Striga gesnerioides* dans un système de rotation des deux espèces. In *Mise au point de techniques de restauration et d’amélioration de la fertilité des sols dans les systèmes de culture à base de mil en zones sahélienne et soudanienne du Mali*. Rapport du Comité de Programme de l’Institut d’Economie Rurale du Mali, (unpublished).

Comparative short-term effects of different quality organic resources on maize productivity under two different environments in Zimbabwe

Florence Mtambanengwe^{1,*}, Paul Mapfumo¹ and Bernard Vanlauwe²

¹Department of Soil Science and Agricultural Engineering, University of Zimbabwe, P.O. Box MP 167, Mount Pleasant, Harare, Zimbabwe; ²Tropical Soil Biology and Fertility Institute of CIAT, P.O. Box 30677, Nairobi, Kenya; *Author for correspondence (e-mail: fmtamba@agric.uz.ac.zw; fax: 263-4-307-304)

Key words: Application rate, Maize yield, Mineral N fertilizer, Organic resource quality, Organic resource quantity

Abstract

Major challenges for combined use of organic and mineral nutrient sources in smallholder agriculture include variable type and quality of the resources, their limited availability, timing of their relative application and the proportions at which the two should be combined. Short-term nutrient supply capacity of five different quality organic resources ranging from high to low quality, namely *Crotalaria juncea*, *Calliandra calothyrsus*, cattle manure, maize stover and *Pinus patula* sawdust were tested in the field using maize as a test crop. The study was conducted on two contrasting soil types at Makoholi and Domboshawa, which fall under different agro-ecological regions of Zimbabwe. Makoholi is a semi-arid area (< 650 mm yr⁻¹) with predominantly coarse sandy soils containing approximately 90 g kg⁻¹ clay while Domboshawa (> 750 mm yr⁻¹) soils are sandy-clay loams with 220 g kg⁻¹ clay. Each organic resource treatment was applied at low (2.5 t C ha⁻¹) and high (7.5 t C ha⁻¹) biomass rates at each site. Each plot was sub-divided into two with one half receiving 120 kg N ha⁻¹ against zero in the other. At Makoholi, there was a nine-fold increase in maize grain yield under high application rates of *C. juncea* over the unfertilized control, which yielded only 0.4 t ha⁻¹. Combinations of mineral N fertilizer with the leguminous resources and manure resulted in between 24% and 104% increase in grain yield against sole fertilizer, implying an increased nutrient recovery by maize under organic–mineral combinations. Maize biomass measured at 2 weeks after crop emergence already showed treatment differences, with biomass yields increasing linearly with soil mineral N availability ($R^2 = 0.75$). This 2-week maize biomass in turn gave a positive linear relationship ($R^2 = 0.82$) with grain yield suggesting that early season soil mineral N availability largely determined final yield. For low quality resources of maize stover and sawdust, application of mineral N fertilizer resulted in at least a seven-fold grain yield increase compared with sole application of the organic resources. Such nutrient combinations resulted in grain harvest indices of between 44% and 48%, up from a mean of 35% for sole application, suggesting the potential of increasing maize productivity from combinations of low quality resources with mineral fertilizer under depleted sandy soils. At Domboshawa, grain yields averaged 7 t ha⁻¹ and did not show any significant treatment differences. This was attributed to relatively high levels of fertility under the sandy-clay loams during this first year of the trial implementation. Differences in N supply by different resources were only revealed in grain and stover uptake. Grain N concentration from the high quality leguminous resources averaged 2% against 1.5% from sawdust treatments. We conclude that early season soil mineral N availability is the primary regulatory factor for maize productivity obtainable under poor sandy soils. Maize biomass at 2 weeks is a potential tool for early season assessment of potential yields

This article has been previously published in the journal "Nutrient Cycling in Agroecosystems" Volume 76 Issues 2–3.

under constrained environments. However, the likely impact on system productivity following repeated application of high N-containing organic materials on different soil types remains poorly understood.

Introduction

Mineral fertilizer use by smallholder farmers in Southern Africa including Zimbabwe, is severely limited by prohibitive purchasing costs and general lack of availability (Scoones et al. 1996; Quiñones et al. 1997). This has resulted in dominantly low-input agricultural systems, which unfortunately cannot sustain household food requirements. In addition, low soil N levels account for continued declines in maize production in the majority of smallholder farms (Woomer and Swift 1994; Sanchez et al. 1997). Consequently, farmers exploit a variety of organic inputs as alternative or supplementary nutrient sources in order to improve and sustain soil productivity (Mugwira and Murwira 1998; Mapfumo and Giller 2001; Giller 2002). Locally available organic nutrient sources are often added in the form of farmyard manure (Mugwira and Murwira 1997), leaf litter (Nyathi and Campbell 1993), crop residues (Campbell et al. 1998; Powell and Unger 1998), green manures (Giller et al. 1998) or agroforestry tree prunings (Mafongoya and Nair 1997; Chikowo et al. 2004). However, most of the available organic resources are of medium to poor quality, and there is paucity of information on their potential to build up the fertility status of these soils or influence their short-term productivity.

Organic resource quality is usually described by the relative concentration of nitrogen (N), lignin and polyphenol in the material, with high-quality resources having high N and low lignin (Heal et al. 1997). These quality parameters form the basis of a Decision Guide for organic N management (Palm et al. 1997, 2001; Giller 2000), which gives a step-by-step characterization of organic resource management based on their N, lignin and polyphenol contents. The Decision Guide proposes critical limits of 2.5% N, 15% lignin and 4% polyphenols. On-farm generation of N rich organic inputs for soil fertility improvement may include crop sequences with leguminous plants or biomass-transfer of green manure species. Green manuring with *Crotalaria* and *Mucuna* has been known to have positive effects on maize yields (Rattray and Ellis 1952; Kumwenda and Gilbert 1998). Some N₂-fixing leguminous

species can fix > 200 kg N ha⁻¹ yr⁻¹ (Mapfumo 2000; Giller 2001). Use of agroforestry tree species such as *Calliandra calothyrsus* in cropping systems may be favourable since the species can accumulate high biomass, has high tissue N content (Handayanto et al. 1997) and grows well on a wide range of soils (Mafongoya and Nair 1997). Incorporation of crop residues favours short-term N immobilization because of their high C:N ratios but repeated addition of crop residues has been known to increase soil organic matter levels (Nicholson et al. 1997).

While it is known that high quality organic inputs release nutrients for uptake by plants in the short-term, information on crop–nutrient interactions necessary for maximizing N availability and N-use efficiency by crops under low to medium quality organic resource management is only beginning to emerge (Giller 2002; Vanlauwe et al. 2002a). Such an understanding of nutrient release dynamics will enable smallholder farmers to manage the different quality organic resources in a manner that optimises nutrient uptake and plant productivity. It is therefore imperative that a scientific understanding of how repeated applications of organic resources of the same quality impact on the short- to long-term fertility status of the soils is developed. This paper addresses the short-term effects of both organic resource quality and quantity on maize yields. The study objectives were: (i) to determine how maize productivity is influenced by different organic resources applied at different C rates, varying organic resource quality and combined effect of mineral N fertilizer and organic resource quality/quantity and (ii) to assess the influence of organic resource quality on maize productivity under different soil textures and rainfall regimes.

Materials and methods

Study area – site descriptions

The study was conducted at two on-station sites, namely Domboshawa Training Centre, 30 km north of Harare (31°19' E and 17°36' S) in Natural Region (NR) II, and Makoholi Research Station,

Table 1. Soil attributes of the top 20 cm at Domboshawa and Makoholi, Zimbabwe.

Attribute	Experimental station	
	Domboshawa	Makoholi
Organic C (g kg ⁻¹)	7.3 (1)	4.0 (0.1)
Total N (g kg ⁻¹)	0.7 (0.1)	0.46 (0.2)
Mineralizable N (mg kg ⁻¹)	40.0 (0.2)	18 (0.1)
Total P (g kg ⁻¹)	0.2 (0.04)	0.12 (0.01)
Olsen P (mg kg ⁻¹)	6.3 (0.51)	7.40 (0.34)
Calcium (cmol ₊ kg ⁻¹)	0.8 (0.1)	0.06 (0.04)
Magnesium (cmol ₊ kg ⁻¹)	0.7 (0.06)	0.15 (0.02)
Potassium (cmol ₊ kg ⁻¹)	0.2 (0.04)	0.03 (0.01)
Sand (g kg ⁻¹)	730	820
Silt (g kg ⁻¹)	50	90
Clay (g kg ⁻¹)	220	90
Bulk density (g cm ⁻³)	1.3 (0.12)	1.50 (0.04)
pH (1:2.5 soil:water)	5.3 (0.2)	4.7 (0.1)

Figures in parentheses indicate standard error.

about 280 km south of Harare (30°45' E and 19°47' S) in NR IV. Agro-zonation in Zimbabwe is mainly defined in terms of the amount of mean rainfall received annually. Natural Region II is a sub-humid zone that receives between 750 and 1050 mm during the period of November–March, while NR IV is a semi-arid area subject to frequent seasonal droughts with mean annual rainfall of between 450 and 650 mm (Vincent and Thomas 1961). The soils of both sites are well drained, moderately shallow to deep sands (up to 1.4 m) derived from granitic parent material (Thompson and Purves 1981; Anderson et al. 1993). The soils at Domboshawa may be defined as Haplic lixisols (FAO 1988) or Typic Kandiusstalfs (Soil Survey Staff 1990) ranging from sandy clay loams of poor to moderate fertility while Makoholi is characterized by relatively infertile coarse sands, Arenosols (FAO 1988) inherently low in organic C and N (Table 1).

Organic resource selection and characterization

The field experiment is part of a long-term trial established in 2001 in collaboration with Tropical Soil Biology and Fertility's Institute of CIAT (TSBF-AfNet). The study is aimed at investigating the influence of continuous but repeated application of different quality and quantities of organic resources on SOM dynamics (Mapfumo et al. 2001). Five different quality organic resources,

Table 2. Quality of organic resources at time of field incorporation at Domboshawa and Makoholi experimental sites in Zimbabwe.

Organic resource type	N (%)	C (%)	C:N	Lignin (%)	Polyphenol (%)
<i>Crotalaria juncea</i> green manure	3.1	45	14	6.5	1.8
<i>Calliandra calothyrsus</i> prunings	2.9	45	16	19.0	4.6
<i>Zea mays</i> stover	0.9	45	53	2.9	1.0
<i>Pinus patula</i> sawdust	0.3	44	163	28.1	0.6
Cattle manure	1.1	30	28	2.9	0.2

four of which conformed to the four categories identified in the Decision Guide for organic N management (Palm et al. 1997; Giller 2000), were broadcast and hand-incorporated to a depth of about 15–20 cm at the Domboshawa and Makoholi experimental sites, about 2 weeks before planting a maize (*Zea mays* L.) test crop. The materials were:

- (i) *Crotalaria juncea* green manure – high quality with N > 2.5%, lignin < 15% and polyphenols < 4%
- (ii) *Calliandra calothyrsus* prunings – medium quality with N > 2.5%, lignin > 15% and polyphenols > 4%
- (iii) Maize stover – low quality with N < 2.5%, lignin < 15% and polyphenols < 4%
- (iv) *Pinus patula* sawdust – low quality with N < 2.5%, lignin > 15% and polyphenols < 4% (Table 2).

The fifth organic fertilizer was cattle manure, a common soil amendment used by many small-holder farmers which, because of variability in quality, does not generally conform to Decision Guide (Murwira et al. 2002). Laboratory analysis showed that the manure used for the study was of medium quality with N < 2.5%, lignin < 15% and low polyphenol contents of < 4%. The C:N ratios of the different materials ranged from 14 for *C. juncea* to 163 for sawdust (Table 2).

Generation of organic resources

During the 2001–2002 cropping season, *C. juncea* and a short-season maize hybrid cultivar SC 513

(140 days to maturity) were planted at Domboshawa and Makoholi. At flowering, *C. juncea* was harvested and air-dried in the shade away from direct sunlight to maintain optimum tissue N contents. The maize crop was allowed to reach physiological maturity before harvesting. Both *C. juncea* and mature maize stover were chopped into pieces ranging between 15 and 25 cm before incorporation. *Calliandra calothyrsus* prunings were acquired from the World Agroforestry Centre (ICRAF) sites at both Domboshawa and Makoholi. Cattle manure was acquired locally at each site as each of the respective sites have a livestock component. The manure was heap stored, as is the local practice among many Zimbabwean smallholder farmers, before incorporation. Pine sawdust was collected from a sawmill in Marondera, about 75 km east of Harare.

Field layout and experimental treatments

Each of the five organic resources described above was applied at two carbon-based rates of 2.5 t C ha⁻¹ (low rate) and 7.5 t C ha⁻¹ (high rate). Plots receiving each of these treatment levels, including a non-amended control, were sub-divided into two, with one half receiving 120 kg N ha⁻¹ while the other received no mineral N fertilizer. The experiment was a split plot design with mainplots allocated to organic resource quality × C application rate and sub-plots to the two mineral N fertilizer levels. Each mainplot measured 12 × 6 m² and each subplot measured 6 × 6 m². Each treatment was replicated three times at each site.

All plots received a blanket basal application of 16 kg P ha⁻¹ and 15 kg K ha⁻¹ in line with the area recommended rates prior to planting maize. The maize test-crop was planted on 11 December, 2002 at Domboshawa and on 17 December at Makoholi, soon after the first effective rains that marked the beginning of the 2002–2003 cropping season. An early maturing cultivar (SC 401) was planted under low rainfall at Makoholi while a medium maturing cultivar (SC 513) was planted at Domboshawa. A spacing of 0.3 m within rows and 0.9 m between rows was used giving a total of ~37,000 plants ha⁻¹. Two seeds were planted at each station, and the seedlings thinned to one per station at 2 weeks after crop emergence (WAE).

The maize was kept weed-free through hand hoeing. About 120 kg N ha⁻¹ in Ammonium nitrate form (34.5% N) was applied in three splits. The first split was applied at 2 WAE (30% of total) followed by 40% at 6 WAE and finally the last 30% was applied at 9 WAE when the maize was silking. At 6 WAE, the maize crop was treated for maize stalk borer (*Busseola fusca*) using Kombat (2.5% Carbaryl) at 3–4 kg ha⁻¹. Maize shoot biomass and grain yield determinations were made from a net plot measuring 10.26 m² for each subplot. Maize biomass yields were determined (i) during thinning at 2 WAE before the first split of mineral N application, and (ii) at the end of the season during which grain and stover yields were also determined. Grain yield was calculated at 12.5% moisture content. Grain harvest index was calculated in terms of grain yield expressed as a percentage of the total shoot biomass.

Mineral N dynamics

Soils from the different treatments were collected from a depth of 0–20 cm for mineral N (NH₄⁺-N and NO₃⁻-N) determination at approximately 4 weeks after organic resource incorporation. Sampling was done before application of mineral N fertilizer at 2 WAE. Soil samples were collected from three points within each subplot using an auger, before a composite sample was drawn for analysis. The composite samples were put in airtight polythene bags and stored at 4 °C prior to extraction with 1 M KCl within 2 days of sampling. In the laboratory, 10 g of field moist soil were weighed into a 100 ml container for extraction with 50 ml of 1 M KCl. The soils were shaken on an end-over-end shaker for 1 h, centrifuged and the clear supernatant transferred into a new set of 100 ml plastic containers. Another subsample of 25 g soil was placed in an oven at 105 °C for 24 h to determine the soil moisture content at the time of sampling. Both NH₄⁺-N and NO₃⁻-N were determined colorimetrically using a UV-visible spectrophotometer, Shimadzu BioSpec Model 1601. Ammonium-N was determined using the phenate method while quantification of soil NO₃⁻-N was done using the NO₂⁻-N cadmium reduction method as described by Keeney and Nelson (1982). Total plant available mineral N was calculated as the sum of NH₄⁺-N and NO₃⁻-N.

Data analysis

Data were analyzed by analysis of variance (ANOVA) and mean comparisons on the effects of the five organic resources with and without mineral N applications on maize yield were done using Genstat for Windows Discovery Edition 1 (2003). Regression analyses were carried out to determine relationships between (i) early mineral N availability and maize biomass at 2 weeks after crop emergence, and (ii) maize biomass at 2 weeks after crop emergence and final grain yield. Mention of statistical significance refers to $P < 0.05$ unless otherwise stated.

Results

Influence of organic resource quality and quantity on maize productivity

Treatment effects on maize productivity were already apparent within 2 weeks of crop emergence at both sites, with yields ranging between 4 and 18 kg ha⁻¹ at Makoholi and 7–31 kg ha⁻¹ under high rainfall at Domboshawa. Increasing organic resource application rates from 2.5 to 7.5 t C ha⁻¹ significantly improved maize productivity by over 50% for *C. juncea* and *C. calothyrsus* treatments at Makoholi. During the same period, maize biomass yields under maize stover and sawdust treatments were depressed by between 14% (low rate maize stover) and 27% (low rate sawdust) against the control. Overall, maize productivity during this early growth phase increased linearly with soil mineral N availability at both Makoholi ($R^2 = 0.75$) and Domboshawa ($R^2 = 0.61$) (Figure 1). At Makoholi, maize biomass at 2 WAE following *C. calothyrsus* and *C. juncea* were 135–200% higher than the control. Early season mineral N availability was highest under the high rate *C. juncea* treatment, with about 20 mg N kg⁻¹ soil in the top 20 cm of the soil profile 4 weeks after biomass incorporation. The remainder of the treatments mineralized < 12 mg N kg⁻¹, with the least amounts of plant available N being found in soils under sawdust, maize stover and control treatments (Figure 1). The same pattern was observed at Domboshawa, although the magnitude of differences in maize biomass yields among treatments was low. High application rates of

C. juncea gave at least 60% more biomass than the control, and soil mineral N availability in the top 20 cm of the profile under this treatment averaged 25 mg N kg⁻¹ soil within 4 weeks of biomass incorporation (Figure 1). The rest of the treatments mineralized between 6 and 16 mg N kg⁻¹ soil during the same period, except sawdust and high rate maize stover treatment which mineralized < 4 mg N kg⁻¹ soil. This could partly explain the low yield recorded under these treatments.

Both resource quality and application rate had a significant ($P < 0.001$) effect on maize grain and total biomass yield at Makoholi. Grain yields ranged from 0.1 t ha⁻¹ under sawdust treatments to 4.1 t ha⁻¹ under high rate *C. juncea* plus mineral N fertilizer (Table 3), and the respective biomass yields ranged from 0.4 to 7.0 t ha⁻¹. Addition of mineral N fertilizer to the high rate *C. juncea* treatment only resulted in a 14% increase in maize grain yield compared with a more than ten-fold increase under sawdust treatments. When compared to the control, application of *C. juncea* at high rates increased yields by > 800%, while an apparent grain yield loss of > 60% was evident under sawdust treatments.

Under relatively high rainfall at Domboshawa, similar maize grain yield patterns were observed although there were no significant treatment differences. Total maize biomass yields only ranged between 14 and 18 t ha⁻¹ for the different treatments with the high quality legumes resources and manure consistently out-yielding maize stover, sawdust and control treatments. Lack of treatment differences was attributed to a relatively high background fertility of soils in this first year of cropping. Addition of mineral N fertilizer did not result in any significant ($P < 0.05$) yield differences relative to unfertilized treatments. The highest grain yields of 8.3 t ha⁻¹ were under the high rate manure plus mineral N, while the least was 5.2 t ha⁻¹ under high rate of sawdust combined with mineral N fertilizer (Table 3). Maize grain yield data from both sites gave a positive linear relationship with maize biomass yields at 2 WAE ($R^2 = 0.82$) (Figure 2).

The grain harvest index (GHI) under the different treatments ranged from 27% in the unfertilized control to 56% under *C. juncea* at Makoholi. This suggested a wide variability in relative contributions by the different quality materials towards the grain yield component. In contrast, there was little variability in GHI at Domboshawa ranging from 44

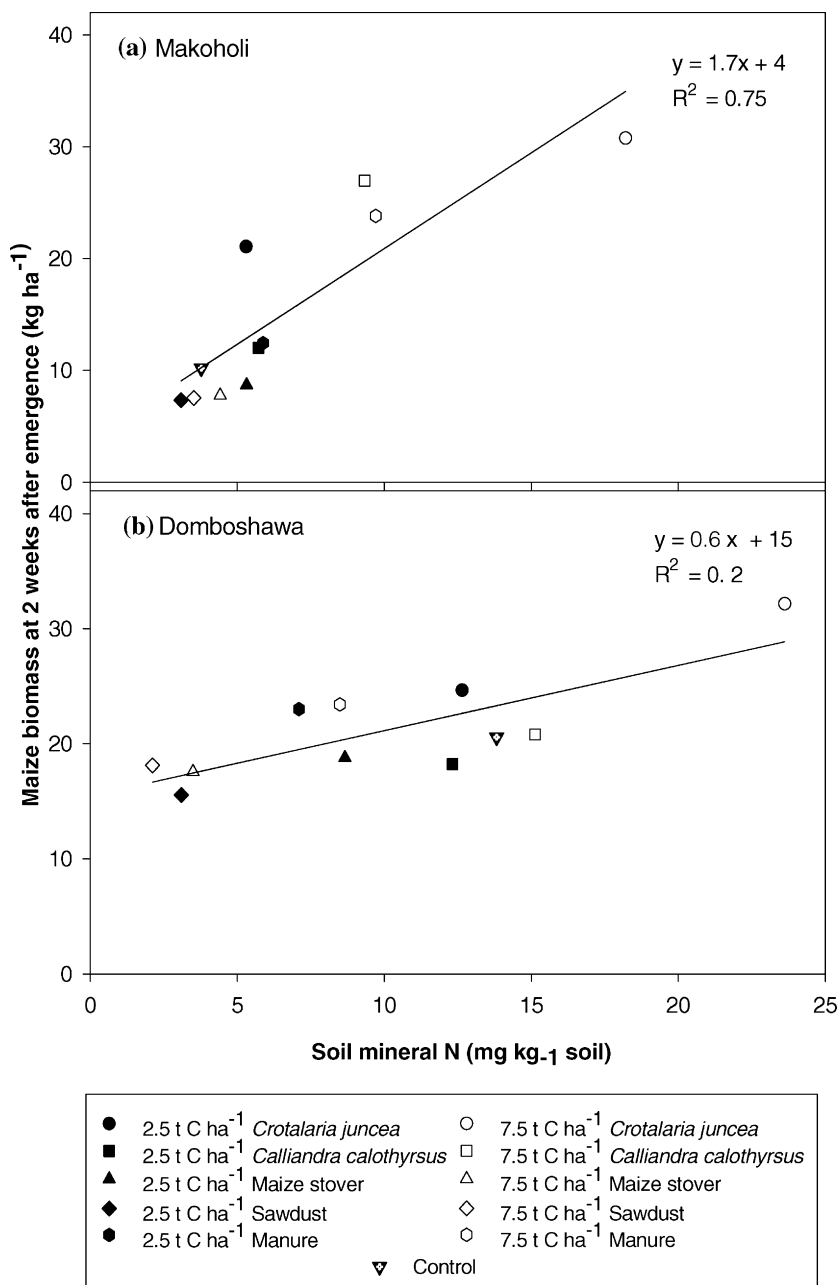

Figure 1. Relationship between soil mineral N availability (before mineral N fertilizer application) and a 2 week-old maize crop at Makoholi (a) and Domboshawa (b) under different quantities and quality organic resources.

under maize stover (unfertilized) to 59% under the N-fertilized control (Table 3). Overall, it was apparent that application of mineral N improved GHI for all the treatments at Makoholi, but there were no clear trends at Domboshawa probably due to the minimal benefits of the applied N fertilizer at this site during this first year of trial implementation.

Relative contributions of different nutrient sources on grain yield

Partitioning of treatment effects on grain yield at Makoholi, showed net yield benefits from mineral N fertilizer for all treatments, with low rate manure giving the highest fertilizer returns of up

Table 3. Maize grain yield and harvest index as influenced by organic resource quality and application rate under contrasting environments in Zimbabwe.

Treatment	Biomass application rate (t C ha ⁻¹)	N application rate (kg ha ⁻¹)	Makoholi (Mean annual rainfall = < 650 mm)		Domboshawa (Mean annual rainfall = > 750 mm)	
			Grain yield (t ha ⁻¹)	GHI* (%)	Grain yield (t ha ⁻¹)	GHI* (%)
Crotalaria juncea	2.5	0	1.5	45	6.9	49
	2.5	120	2.6	53	7.7	54
	7.5	0	3.6	56	8.0	54
	7.5	120	4.1	53	8.0	47
<i>Calliandra Calothyrsus</i>	2.5	0	0.4	36	7.2	51
	2.5	120	1.9	49	7.1	49
	7.5	0	1.3	44	8.0	56
	7.5	120	2.8	56	7.8	46
Maize stover	2.5	0	0.2	43	7.1	44
	2.5	120	1.6	46	6.9	52
	7.5	0	0.4	35	7.1	54
	7.5	120	1.7	48	6.5	50
<i>Pinus patula</i> sawdust	2.5	0	0.1	30	6.8	51
	2.5	120	1.3	47	6.1	48
	7.5	0	0.1	32	6.6	46
	7.5	120	1.0	44	5.2	48
Cattle manure	2.5	0	0.8	45	6.6	53
	2.5	120	2.5	55	6.6	50
	7.5	0	1.7	50	6.9	52
	7.5	120	2.5	51	8.3	56
Control	–	0	0.4	27	6.9	59
	–	120	1.7	54	7.5	52
SED ^a	–	–	0.1	1.5	0.3	1.5
SED ^b	–	–	0.2	4.0	0.7	3.4

* – Grain Harvest Index; SED = Standard error of the difference between means for ^aMineral N fertilizer effects, and ^bOrganic resource quality.

to 1.3 t ha⁻¹ (Table 4). There was apparently little additional yield benefit in applying N fertilizer to the high rate *C. juncea* treatment, as this accounted for only 3% total yield. Mineral fertilizer effects were more significant under low rate organic resource application compared to higher application rates of the same quality resources. At these low rates, more than 50% of total yield attained under medium to low quality resources was apparently due to mineral N fertilizer effects, against 27% for the high quality *C. juncea*. In contrast, mineral N fertilizer accounted for mere 3–16% of total yield under high organic resource application (Table 4). Irrespective of application rates, organic×mineral N fertilizer interaction apparently depressed potential grain yield for both high quality (*C. juncea*) and low quality (sawdust) treatments. Pronounced positive effects were only revealed under the medium quality resources. For instance

C. calothyrsus, low application rates of manure and maize stover all exhibited positive benefits from the organic×mineral N combination effects (Table 4).

Contrary to the patterns observed at Makoholi, mineral N fertilizer addition apparently had a depressive effect on yield across all treatments under the relatively fertile soils at Domboshawa. Potential yield losses of > 6 t ha⁻¹ were apparent for all treatments except low rate sawdust which had an apparent grain loss of only 0.7 t ha⁻¹. The true mineral N fertilizer effects only accounted for 8% of total yield (Table 4). This suggested that yield gains were attainable with sole applications of medium to high quality organic resources. The organic×mineral N interaction effects were only positive for low rate *C. juncea* and high rate manure where they contributed 3 and 8% of total yield respectively (Table 4).

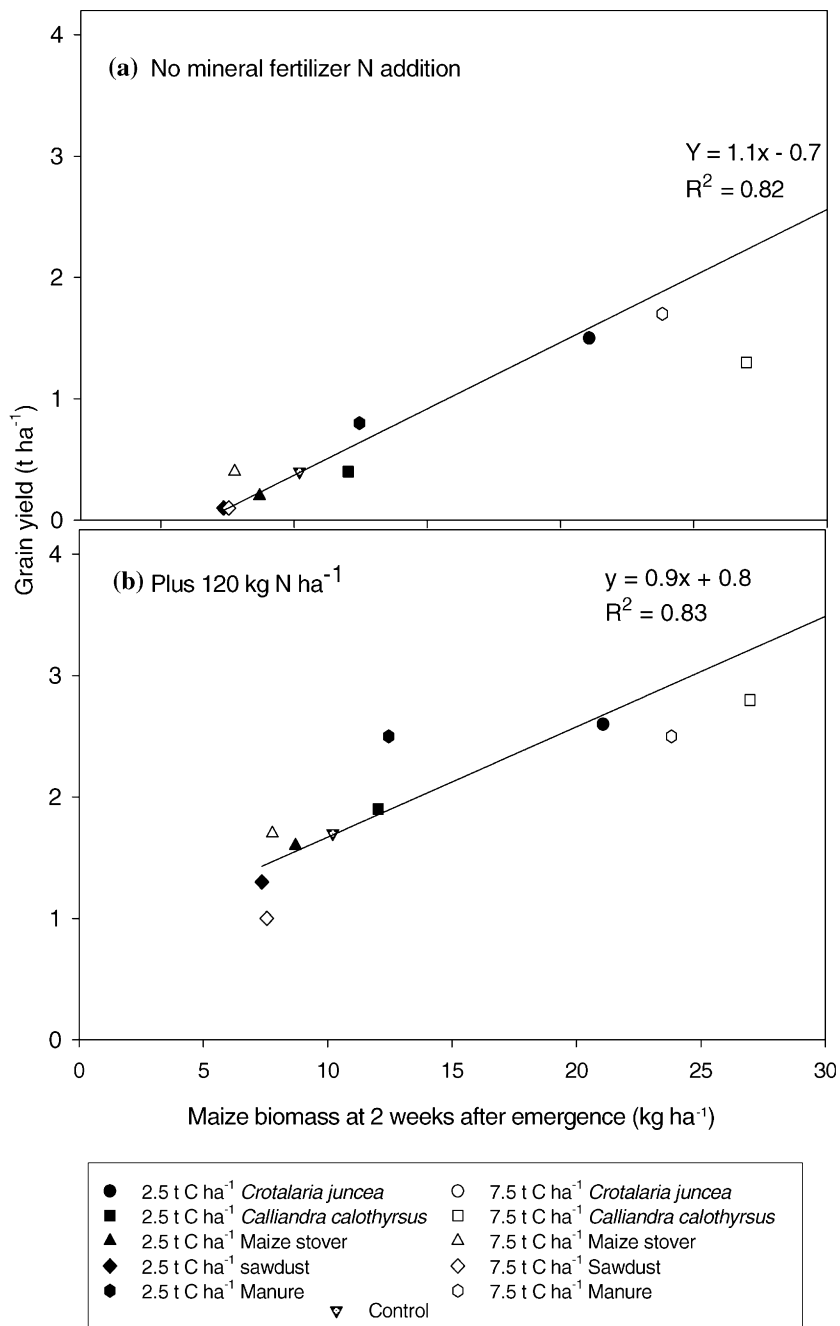

Figure 2. Relationship between maize productivity at two weeks after emergence and final grain yield under low rainfall at Makoholi (a) with no mineral fertilizer N addition and (b) plus 120 kg N ha⁻¹.

Nitrogen uptake patterns

Contrary to grain and biomass yields, N uptake in grain and stover showed significant treatment effects at Domboshawa. Carbon application rate, N

level and organic resource quality all affected the pattern of grain and stover N uptake. Notable was the highly significant ($P < 0.001$) effect of organic resource quality on maize N quality (Table 5). Maize grain from higher quality organic resource

Table 4. Relative contribution of mineral fertilizer and organic×mineral fertilizer interaction effects to maize grain yield as influenced by organic resource quality under different environments in Zimbabwe.

Treatment	Makoholi		Domboshawa	
	Yield benefits (kg ha ⁻¹)			
	2.5 t C ha ⁻¹	7.5 t C ha ⁻¹	2.5 t C ha ⁻¹	7.5 t C ha ⁻¹
<i>Crotalaria juncea</i>				
Mineral fertilizer effects ^a	700	100	-6100	-6900
Interaction effects ^b	-200	-800	200	-600
<i>Calliandra calothyrsus</i>				
Mineral fertilizer effects	1100	1100	-7000	-7100
Interaction effects	200	200	-70	-800
Manure				
Mineral fertilizer effects	1300	500	-6900	-8300
Interaction effects	400	-500	-600	800
Maize stover				
Mineral fertilizer effects	1000	900	-7600	-5500
Interaction effects	100	0	-800	-1200
Sawdust				
Mineral fertilizer effects	800	500	-760	-7500
Interaction effects	-100	-400	-1300	-2000
True fertilizer effects ^c	1300		600	
Control	400		6900	

^a Mineral fertilizer effects = Apparent fertilizer effects: (Organic plus mineral N fertilizer treatment – sole organic treatment).

^b Interaction effects = [Organic plus mineral N fertilizer treatment – (true fertilizer effects – true organic treatment) – unamended control].

^c True fertilizer effects = (Fertilizer treatment – control).

Table 5. Statistical significance of organic and mineral nutrient sources on maize and stover N quality at Domboshawa, Zimbabwe.

Source of variation	Grain N	Stover N
Organic resource quality	***	***
C rate ^a	**	**
N level ^b	*	***
Organic resource quality×C rate	*	*
Organic resource quality×N level	ns	ns
C rate×N level	ns	ns
Organic resource quality×C rate×N level	ns	ns

^a Carbon application rate (2.5 and 7.5 t C ha⁻¹).

^b Mineral N fertilizer level at 0 and 120 kg ha⁻¹.

***P < 0.001; **P < 0.01; *P < 0.05; ns – not significant at P < 0.05.

treatments had superior grain N concentration compared to that from low quality resources e.g. a mean of 2.1% N for maize from *C. juncea* treatment compared with 1.5% N for sawdust (Table 6). Application rates of medium to high quality resources at high rates improved the grain N concentration by as much as 10%. The highest increase in stover N concentration of ~25% was under cattle manure. However, there was no

Table 6. The effect of organic resource quality and quantity of application (carbon basis) on maize grain and stover N concentration at Domboshawa in Zimbabwe.

Organic resource quality	Grain N		Stover N	
	2.5 t C ha ⁻¹	7.5 t C ha ⁻¹	2.5 t C ha ⁻¹	7.5 t C ha ⁻¹
<i>Crotalaria juncea</i>	1.92	2.12	0.86	0.98
<i>Calliandra calothyrsus</i>	1.83	2.00	0.86	0.90
Manure	1.68	1.84	0.72	0.90
Maize stover	1.64	1.65	0.74	0.73
<i>Pinus patula</i> sawdust	1.48	1.49	0.69	0.74
SED	0.02		0.02	

SED – Standard error of the difference.

significant difference between the two C application rates with respect to grain and stover N contents under sawdust, maize stover and control treatments (Table 6). Mineral fertilizer addition increased the N concentration of both grain and stover under the different treatments. The N fertilizer effect was more pronounced in stover than grain (P < 0.001). On average, grain N was increased from 1.72 (0.02) to 1.78 (0.02)% N under

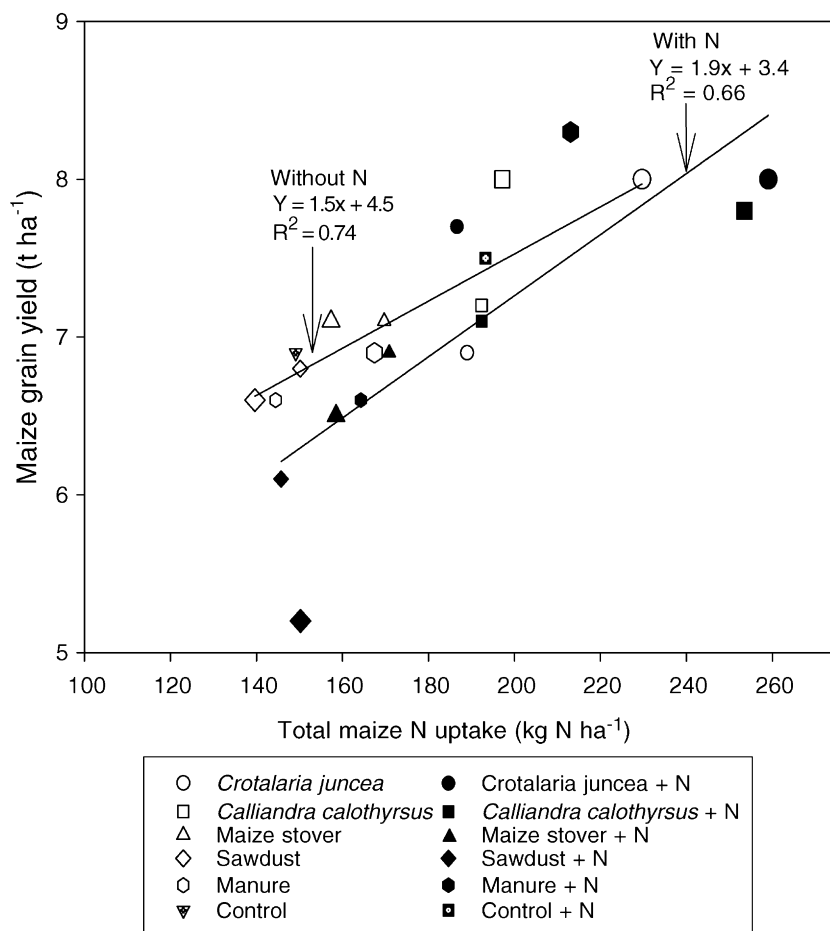

Figure 3. Relationship between maize total N uptake and grain yield under high rainfall conditions at Domboshawa.

mineral N fertilization. Without N fertilization, the N quality of maize stover was ~11% less than under N fertilized treatment.

Total plant N uptake gave a significant linear relationship with grain yield from both N-fertilized ($R^2 = 0.66$) and unfertilized treatments ($R^2 = 0.74$) (Figure 3). Between 140 and 260 kg N ha⁻¹ was accounted for in total plant N uptake under the N-fertilized treatments revealing a wider separation of treatment effects compared to only 140 and 200 kg N ha⁻¹ under sole application. This implied an apparent high plant-N utilization under N fertilized treatments (a slope of 1.9) compared to unfertilized treatments (a slope of 1.5) (Figure 3). However, more efficient uptake of plant-available N was apparent under unfertilized treatments where potentially 47 kg grain kg⁻¹ N taken-up under poor quality resources com-

pared with 35 kg grain kg⁻¹ N under higher quality *C. juncea*. Corresponding values were 42 and 31 kg grain kg⁻¹ N uptake under fertilized treatments (Figure 3).

Discussion

Maize productivity following organic resource incorporation primarily hinged on early season N-supply capacity of the different nutrient sources. Significant responses in maize biomass evident as early as 2 weeks after crop emergence indicated high N requirement by maize during early growth phase (Oikeh et al. 1996). The study suggests that it is this early and consistent supply of N that determines grain yield, as was revealed by a significant relationship between grain yield and maize

biomass at 2 WAE. It was apparent that without fast-N-releasing or high quality organic inputs or mineral fertilizer, biomass accumulation by maize is severely compromised, particularly under sandy soils such as those at Makoholi. Unfortunately, much of arable farmland on smallholder farms are typically sandy and inherently contain low amounts of soil organic matter (Grant 1981; Giller et al. 1997). External nutrient supplementation, particularly N, govern crop production on these soils. Soil mineral N availability could be explained by both the quality and quantity of the different organic resources added, which contained variable amounts of readily mineralizable N. The high performance of maize under *C. juncea* could be attributed to its rapid decomposition and mineralization due to a narrow C:N ratio. The relative proportion of these elements has traditionally been widely accepted as a major determinant of short-term N release patterns (Iritani and Arnold 1960; Swift et al. 1979; Frakenberger and Abelmagid 1985). However, research over the last one and half decades has included lignin and polyphenol contents as key modifiers governing N mineralization/immobilization patterns from different quality materials (Palm and Sanchez 1991; Constantinides and Fownes 1994; Mafongoya et al. 1998). Still, the robustness of the C:N ratio over lignin content in predicting N release from organic materials was implied under medium to high quality *C. calothyrsus* which yielded at least nine-fold against the control. Any immobilization likely to emanate from the highly lignified *C. calothyrsus*, which was way above the critical level of 150 mg kg⁻¹ (Palm et al. 1997) was not evident, suggestive of the dominance of other resource quality modifiers other than lignin and polyphenols. Lack of significant interactions between mineral N fertilizer and with neither organic resource quality nor biomass application rate means that mineral fertilizer had additive effects with the different quality organic resources.

Partitioning of treatment effects on maize yield at both Makoholi and Domboshawa showed marginal positive to negative yield benefits following addition of mineral N to either high or low quality organic resources. While possible short-term consequences of such nutrient combinations may negatively impact on the final yield realized, it was assumed that the mechanisms responsible for this reduction at the two extremes of the organic

quality scale might be completely different. For example, consistently poor maize productivity observed under low quality resources throughout the season might be attributed to a low tissue N concentration of the materials, which was three and eight times below the critical level of 2.5% (Palm 1995). Addition of 120 kg N ha⁻¹ to these treatments probably did not raise the C:N ratio enough to offset N immobilization as maize grain yield continued to be lower than that of the control, particularly under high application rates. Conversely, addition of mineral N to high quality resources may have resulted in poor N utilization by the maize crop due to excessive N loading and resultant leaching. Analysis of the grain from the different treatments however, revealed that much of the N taken up is channelled towards grain, and the grain quality increases with mineral N addition or application of medium to high quality materials. An apparent 10% decrease in grain yield realized from every kilogram of N taken up under mineral N fertilized compared to unfertilized treatments may imply that an enhanced N pool does not necessarily mean high yield. High N availability at early crop growth stages has been deemed undesirable as this promoted luxuriant vegetative growth (Nandwa and Chege 1996) at the expense of cob development. Plant N quality analysis displayed differential effects of N source between stover and grain in the short-term. For instance, the influence of organic resource quality and mineral N addition was more pronounced on stover than grain. The N uptake results suggest that changes in nutrient sources manifest themselves in stover before they can be picked up in grain. However, these results are not conclusive as other factors such as crop hybrid type, soil and environmental conditions affect nutrient uptake patterns (Ojiem et al. 1996).

Grain yield results from Domboshawa revealed that N uptake of about 160 kg N ha⁻¹ (under low quality resources) could result in grain yields of up to 7 t ha⁻¹ suggesting N dilution by the maize crop (Janssen et al. 1990). In comparison, yield increments of < 1 t ha⁻¹ were realized under twice the amount of N taken-up under higher quality organic resource treatments. This means that under relatively fertile soils such as those at Domboshawa, substantial maize productivity can be obtained with minimum N management in short-term. The general lack of treatment differences at

Domboshawa was attributed to a relatively high background fertility of the sandy clay loam soil during this first year of trial. For instance, grain yield increased only 14% following addition of 540 kg N ha⁻¹ in *C. juncea* biomass. Conversely, application of lignified sawdust depressed yields by only 5% against the control. These yield patterns suggest that there was probably enough mineral N in the sandy clay loams at Domboshawa to offset any immobilization that might be caused by low quality materials such as maize stover and sawdust. Pre-season analysis of the sandy clay loams indicated a potential N release capacity of >100 kg N ha⁻¹ within one season. Any imminent response by crops under such relatively fertile soils to external addition of high quality N sources is not likely in the short-term.

Under semi-arid conditions at Makoholi, mineral N fertilizer combinations with low quality resources improved grain harvest indices from <0.35 under the control to >0.45. Such management option implies that if farmers in low potential environments combine mineral N fertilizer with low quality organic resources which are often more readily available compared to higher quality resources, they may be able to significantly increase crop productivity. Nitrogen uptake was more efficient under low N conditions. While use of mineral N fertilizer is not widespread particularly under semi-arid environments of Zimbabwe, since it is considered a risky investment because of unpredictable weather (Mapfumo and Giller 2001), farmers need exposure to field demonstrations of such technologies in order to maximize crop productivity and enhance food security.

Defining manure quality and predicting nutrient release dynamics for arable use has always been problematic due to variability in origin and handling. Contrary to previous findings that manure with a C:N ratio of >23 delays net N release (Murwira and Kirchmann 1993), significant biomass and yields attained under manure treatment (C:N <23) which was of medium quality. Vanlauwe et al. (2002b) argue that manure possibly has multiple roles other than supplying N in crop production. Some mineralization studies (Olsen 1986) have shown that N release from manure is low but can persist throughout the maize growth period. Thus, high yields attainable under manure plus N-fertilizer treatments were probably due to an enhanced available N pool. Overall, use of organic

resources did make a difference on maize productivity particularly on coarse sandy soils. Management strategies that favour intensive use of organic materials should therefore be promoted in cropping systems dominated by such soils.

Conclusions

Maize productivity was governed by N availability with an early supply of N crucial in crop establishment, plant vigour and, therefore, final yield. A 2-week maize crop can be used to estimate grain yield under normal seasons. High quality materials such as *C. juncea* can be used directly as a N source under maize-based systems with increased nutrient use efficiency at higher rates. For low quality organic resources, low application rates gave higher grain yields compared with high rates due to a shortened N immobilization phase. It was concluded that the cattle manure used was of intermediate quality and lies between maize stover and *C. calothyrsus*. The N release capacity of low quality resources can be enhanced by adding mineral N fertilizer, a management option which may be desirable to smallholder farmers who characteristically have access to little amounts of low quality organic nutrient sources. However, the nature of added benefits realized through combinations of the two nutrient sources still needs further investigation. While these findings conform to the Decision Guide for organic N management, the likely long-term effect of repeated applications of large amounts of high quality (high N) organic resources remains largely unknown.

Acknowledgements

This work was funded by the Rockefeller Foundation through the NUESOM Grant to University of Zimbabwe (Grant 2002 FS 189). TSBF-CIAT's AfNet provided seed money for initial establishment of the experiments. Technical staff from Department of Research and Extension (AREX) of the Ministry of Agriculture, Zimbabwe is highly acknowledged for manning the experimental sites. We thank The World Agroforestry Centre (ICRAF) for providing *C. calothyrsus* prunings at respective sites, and TSBF-CIAT for the lignin and polyphenol analyses.

References

- Anderson I.P., Brinn P.J., Moyo M. and Nyamwanza B. 1993. Physical resource inventory of the communal lands of Zimbabwe – an overview. NRI Bulletin No. 60. Natural Resources Institute, Chatham, UK.
- Campbell B.M., Frost P.G.H., Kirchmann H. and Swift M. 1998. A survey of soil fertility management in small-scale farming systems on north-eastern Zimbabwe. *J. Sust. Agric.* 11: 19–39.
- Chikowo R., Mapfumo P., Nyamugafata P. and Giller K.E. 2004. Woody legume fallow productivity, biological N₂-fixation and residual benefits to two successive maize crops in Zimbabwe. *Plant Soil* 262: 303–315.
- Constaninides M. and Fownes J.H. 1994. Nitrogen mineralization from leaves and litter of tropical plants: relationship to nitrogen, lignin and soluble polyphenol concentration. *Soil Biol. Biochem.* 26: 49–55.
- Food and Agricultural Organization. 1988. Soil Map of the World Revised legend. World Soil Resources Report No. 60. FAO, Rome, Italy.
- Frakenberger W.T. and Abelmagid H.M. 1985. Kinetic parameters of nitrogen mineralization rates of legume crops incorporated into soil. *Plant Soil* 87: 257–271.
- GENSTAT Discovery Edition 1. 2003. Genstat Release 4.23DE for Windows. Lawes Agricultural Trust, Rothamsted Experimental Station, Oxford, UK.
- Giller K.E. 2000. Translating science into action for agricultural development in the tropics: an example from decomposition studies. *Appl. Soil Ecol.* 14: 1–3.
- Giller K.E. 2001. Nitrogen Fixation in Tropical Cropping Systems. CABI Publishing, Wallingford, UK.
- Giller K.E. 2002. Targeting management of organic resources and mineral fertilizers: can we match scientists' fantasies with farmers' realities?. In: Vanlauwe B., Diels J., Sanginga N. and Merckx R. (eds), *Integrated Plant and Nutrient Management in sub-Saharan Africa: From Concept to Practice*. CAB International, Wallingford, UK, pp. 155–172.
- Giller K.E., Cadisch G., Ehaliotis C., Adams E., Sakala W.D. and Mafongoya P.L. 1997. Building soil nitrogen capital in Africa. In: Buresh R.J., Sanchez P.A. and Calhoun F. (eds), *Replenishing Soil Fertility in Africa*. ASA, CSSA, SSSA Special Publication 51, Madison, WI, USA, pp. 151–192.
- Giller K.E., Gilbert R., Mugwira L.M., Muza L., Patel B.K. and Waddington S. 1998. Practical approaches to soil organic matter management for smallholder maize production in Southern Africa. In: Waddington S.R., Murwira H.K., Kumwenda J.D.T., Hikwa D. and Tagwira F. (eds), *Soil Fertility Research for Maize-Based Farming Systems in Malawi and Zimbabwe*. SoilFertNet and CIMMYT-Zimbabwe, Harare, Zimbabwe, pp. 139–153.
- Grant P.M. 1981. The fertilization of sandy soils in peasant agriculture. *Zim. Agric. J.* 78: 169–175.
- Handayanto E., Giller K.E. and Cadisch G. 1997. Nitrogen mineralization from mixtures of legume tree prunings of different quality and recovery of nitrogen by maize. *Soil Biol. Biochem.* 29: 1417–1426.
- Heal O.W., Anderson J.M. and Swift M.J. 1997. Plant litter quality and decomposition: An historical overview. In: Cadisch G. and Giller K.E. (eds), *Driven by Nature*. Plant Litter Quality and Decomposition. CAB International, Wallingford, pp. 3–30.
- Iritani W.M. and Arnold C.Y. 1960. Nitrogen release of vegetable crop residues during incubation as related to their chemical composition. *Soil Sci.* 89: 74–82.
- Janssen B.H., Guiking F.C.T., van der Eijk D., Smaling E.M.A., Wolf J. and van Reuler H. 1990. A system for quantitative evaluation of the fertility of tropical soils (QUEFTS). *Geoderma* 46: 299–318.
- Keeney D.R. and Nelson D.W. 1982. Nitrogen – inorganic forms. In: Page A.L., Miller P.H. and Keeney D.R. (eds), *Methods of Soil Analysis*. Agronomy 9, 2nd ed. American Society of Agronomy, Madison, Wisconsin, USA, pp. 643–698.
- Kumwenda J.D.T. and Gilbert R. 1998. Biomass production by legume green manures on exhausted soils in Malawi: A soil fertility network trial. In: Waddington S.R., Murwira H.K., Kumwenda J.D.T., Hikwa D. and Tagwira F. (eds), *Soil Fertility Research for Smallholder Maize-based systems in Malawi and Zimbabwe*. SoilFertNet and CIMMYT-Zimbabwe, Harare, Zimbabwe, pp. 85–86.
- Mafongoya P.L., Giller K.E. and Palm C.A. 1998. Decomposition and nitrogen release patterns of tree prunings and litter. *Agrofor. Syst.* 38: 77–97.
- Mafongoya P.L. and Nair P.K.R. 1997. Multipurpose tree prunings as sources of nitrogen to maize under semi-arid conditions in Zimbabwe: Interactions of pruning quality and time and method of application on nitrogen recovery by maize in two soil types. *Agrofor. Syst.* 37: 1–14.
- Mapfumo P. 2000. Potential Contribution of Legumes to Soil Fertility Management in Smallholder Farming Systems of Zimbabwe: The Case of Pigeonpea (*Cajanus cajan* [L] Millsp.). D.Phil Thesis, Department of Soil Science and Agricultural Engineering. University of Zimbabwe, Harare, Zimbabwe.
- Mapfumo P. and Giller K.E. 2001. Soil Fertility Management Strategies and Practices by Smallholder Farmers in Semi-Arid Areas of Zimbabwe. P.O. Box 776, Bulawayo, Zimbabwe: International Crops Research Institute for the Semi-Arid Tropics (ICRISAT) with permission from the Food and Agriculture Organization of the United Nations (FAO).
- Mapfumo P., Mtambanengwe F., Nandwa S., Yeboah E. and Vanlauwe B. 2001. Soil Organic Matter Dynamics for Sustainable Cropping and Environmental Management in Tropical Systems: Effect of Organic Resource Quality and Diversity. TSBF-AfNet SOM Network Proposal. TSBF-CIAT, Nairobi, Kenya.
- Mugwira L.M. and Murwira H.K. 1997. Use of Cattle Manure to Improve Soil Fertility in Zimbabwe: Past and Current Research and Future Research Needs. Network Working Paper No. 2. Soil Fertility Network for Maize-Based Cropping Systems in Zimbabwe and Malawi. CIMMYT, Harare, Zimbabwe.
- Mugwira L.M. and Murwira H.K. 1998. A review of research on cattle manure as a soil fertility amendment in Zimbabwe some perspectives. In: Waddington S.R., Murwira H.K., Kumwenda J.D.T., Hikwa D. and Tagwira F. (eds), *Soil Fertility Research for Maize-Based Farming Systems in Malawi and Zimbabwe*. Soil Fert Net and CIMMYT-Zimbabwe, Harare, Zimbabwe, pp. 195–202.

- Murwira H. and Kirchmann H. 1993. Carbon and nitrogen mineralization of cattle manures, subjected to different treatments, in Zimbabwean and Swedish soils. In: Mulongoy K. and Merckx R. (eds), *Soil Organic Matter Dynamics and Sustainability of Tropical Agriculture*. John Wiley and Sons, Chichester, UK, pp. 189–198.
- Murwira H.K., Mutuo P., Nhamo N., Marandu A.E., Rabeson R., Mwale M. and Palm C.A. 2002. Fertilizer equivalent values of organic materials of differing quality. In: Vanlauwe B., Diels J., Sanginga N. and Merckx R. (eds), *Integrated Plant and Nutrient Management in sub-Saharan Africa: From Concept to Practice*. CAB International, Wallingford, pp. 113–122.
- Nandwa S.M. and Chege A.G. 1996. Fertilizer use by maize in response to rainfall regimes. In: Ransom J.K., Palmer A.F.E., Zambezi B.T., Mduruma Z.O., Waddington S.R., Pixley K.V. and Jewell D.C. (eds), *Maize Productivity Gains Through Research and Technology Dissemination*. Proceedings of the 5th Eastern, Southern Africa Regional Maize Conference, Arusha, Tanzania. 7 June 1996, CIMMYT, Addis Ababa, pp. 197–199.
- Nicholson F.A., Chambers B.J., Mills A.R. and Stachan P.J. 1997. Effects of repeated straw addition on crop fertilizer requirements, soil mineral nitrogen and nitrate leaching losses. *Soil Use Mgt.* 13: 136–142.
- Nyathi P. and Campbell B.M. 1993. The acquisition and use of miombo litter by small-scale farmers in Masvingo, Zimbabwe. *Agrofor. Syst.* 22: 43–48.
- Oikeh S., Kling J.G., Horst W.J. and Chude V.O. 1996. Yield and N-use efficiency of five tropical maize genotypes under different N levels in the moist savanna of Nigeria. In: Ransom J.K., Palmer A.F.E., Zambezi B.T., Mduruma Z.O., Waddington S.R., Pixley K.V. and Jewell D.C. (eds), *Maize Productivity Gains Through Research and Technology Dissemination*. Proceedings of the 5th Eastern, Southern Africa Regional Maize Conference, Arusha, Tanzania, 3–7 June 1996. CIMMYT, Addis Ababa, pp. 163–167.
- Oijem J.O., Ransom J.K. and Wakhonya H.W. 1996. Performance of hybrid and unimproved maize varieties under fertilized and non-fertilized production systems in western Kenya. In: Ransom J.K., Palmer A.F.E., Zambezi B.T., Mduruma Z.O., Waddington S.R., Pixley K.V. and Jewell D.C. (eds), *Maize Productivity Gains Through Research and Technology Dissemination*. Proceedings of the 5th Eastern, Southern Africa Regional Maize Conference, Arusha, Tanzania, 3–7 June 1996. CIMMYT, Addis Ababa, pp. 149–152.
- Olsen S.R. 1986. The role of organic matter and ammonium in producing high corn yields. In: Chen Y. and Avnimelech Y. (eds), *The Role of Organic Matter in Modern Agriculture*. Martinus Nijhoff Publishers, Dordrecht, The Netherlands, pp. 29–54.
- Palm C.A. 1995. Contribution of agroforestry trees to nutrient requirements of intercropped plants. *Agrofor. Syst.* 30: 105–124.
- Palm C.A., Gachengo C.N., Delve R.J., Cadisch G. and Giller K.E. 2001. Organic inputs for soil fertility management in tropical agroecosystems: application of an organic resource database. *Agric. Ecosyst. Environ.* 83: 27–42.
- Palm C.A., Myers R.J.K. and Nandwa S.M. 1997. Combined use of organic and inorganic nutrient sources for soil fertility maintenance and replenishment. In: Buresh J.R., Sanchez P.A. and Calhoun F. (eds), *Replenishing Soil Fertility in Africa*. ASA, CSSA, SSSA Special Publication 51, Madison, WI, USA, pp. 193–217.
- Palm C.A. and Sanchez P.A. 1991. Nitrogen release from some tropical legumes as affected by lignin and polyphenol contents. *Soil Biol. Biochem.* 23: 83–88.
- Powell J.M. and Unger P.W. 1998. Alternatives to crop residues for sustaining agricultural productivity and natural resource conservation. *J. Sust. Agric.* 11: 59–84.
- Quiñones M.A., Borlaug N.E. and Dowsell C.R. 1997. A fertilizer-based green revolution for Africa. In: Buresh J.R., Sanchez P.A. and Calhoun F. (eds), *Replenishing Soil Fertility in Africa*. SSSA Special Publication 51. Soil Science Society of America, Madison, Wisconsin, USA, pp. 81–96.
- Rattray A.G.H. and Ellis B.S. 1952. Maize and green manuring in southern Rhodesia. *Rhod. Agric. J.* 49: 188–197.
- Scoones I., Chibudu C., Chikura S., Jeranyama P., Machaka D., Machanja W., Mavedzenge B., Mombeshora B., Mudhara M., Mudziwo C., Murimbarimba F. and Zirereza B. 1996. Hazards and Opportunities. *Farming Livelihoods in Dryland Africa: Lessons from Zimbabwe*. Zed Books Ltd, London and New Jersey, in association with International Institute for Environment and Development, London, UK.
- Sanchez P.A., Shepherd K.D., Soule M.J., Place F.M., Buresh R.J., Izac A.N., Mokunye A.U., Kwesiga F.R., Ndiritu C.G. and Woomer P.L. 1997. Soil fertility replenishment in Africa: An investment in natural resource capital. In: Buresh J.R., Sanchez P.A. and Calhoun F. (eds), *Replenishing Soil Fertility in Africa*. ASA, CSSA, SSSA Special Publication 51, Madison, WI, USA, pp. 1–46.
- Soil Survey Staff. 1990. *Keys to Soil Taxonomy*. 4th Edition. SSS Technical Monograph. No. 6. Blacksburg, Virginia, USA.
- Swift M.J., Heal O.W. and Anderson J.M. 1979. *Decomposition in Terrestrial Ecosystems*. Blackwell Scientific Publications, Oxford, UK.
- Thompson J.G. and Purves W.D. 1981. *A Guide to the Soils of Zimbabwe*. *Zim. Agric. J. Technical Handbook* 3.
- Vanlauwe B., Diels J., Aihou K., Iwuafor E.N.O., Lyasse O., Sanginga N. and Merckx R. 2002a. Direct interactions between N fertilizer and organic matter: Evidence from trials with ¹⁵N-labelled fertilizer. In: Vanlauwe B., Diels J., Sanginga N. and Merckx R. (eds), *Integrated Plant and Nutrient Management in sub-Saharan Africa: From Concept to Practice*. CAB International, Wallingford, UK, pp. 173–184.
- Vanlauwe B., Palm C.A., Murwira H.K. and Merckx R. 2002b. Organic resource management in sub-Saharan Africa: validation of a residue quality-driven support system. *Agronomie* 22: 839–846.
- Vincent V. and Thomas R.G. 1961. *An Agroecological Survey of Southern Rhodesia: Part 1 – Agro-Ecological Survey*. Government Printer, Salisbury, Rhodesia.
- Woomer P.L. and Swift M.J. 1994. *The Biological Management of Tropical Soil Fertility*. Wiley-Sayce Chichester, UK.

Improving soil fertility through the use of organic and inorganic plant nutrient and crop rotation in Niger

Adamou^{1,*} A., Bationo² A., Tabo¹ R. and Koala¹ S.

¹ICRISAT Niamey, BP 12404, Niamey NIGER; *Corresponding author Tel: (227) 72 25 29, Fax: (227) 73 43 29, E-mail: a.abdou@cgiar.org; ²The Tropical Soil Biology and Fertility Institute of CIAT, P.O Box 30677, Nairobi, Kenya

Abstract

Food production can be increased through the integration of organic and inorganic nutrient sources coupled with proper land management. Niger is one of the poorest countries in the Sahelian zone of West Africa where soil fertility and rainfall are the most limiting factors for crop production. The majority of the people in this region depend on subsistence agriculture for their livelihood. The population pressure has decreased the availability of arable land and the use of extended fallow periods to restore soil fertility is not possible.

Research results have shown that yields can be increased up to five times with the improvement of soil fertility using a combination of soil tillage, organic and inorganic fertilizers than under traditional practice. Crop yields have also been shown to increase substantially using rotation of cereals with legume or intercropping. Yields of pearl millet can be doubled following cowpea as compared to continuous pearl millet cultivation. These combinations can improve soil properties such as Organic carbon content, Cation Exchange Capacity (CEC) and pH.

There is however a constraint to the applicability of combining inorganic and organic fertilizers due to the high costs of inorganic fertilizers and the low availability of organic fertilizers at the farm level. But it can be addressed by incorporating grain legume production such as cowpea into the cropping system. The grain, which has high market value, can be sold for buying external inputs such as fertilizer and fodder used for animal feeding. The use of external inputs will result in an increasing biomass at farm level, which increases the crop residue for mulching to mitigate land degradation and increase productivity

Key words: Crop residue, market value, organic and inorganic nutrients, soil fertility, cropping system, millet, cowpea, soil tillage

Introduction

Niger is one of the poorest countries in the Sahelian zone of West Africa where soil fertility and rainfall are the most limiting factors for crop production. The majority of the people in this region depend on subsistence agriculture for their livelihood. The population pressure has decreased the availability of arable land and the use of extended fallow periods to restore soil fertility is not possible. According to the UNDP Human Development Index, Niger is ranked lowest globally in terms of life expectancy, education, and income in the world (UNDP 1999) According to FAO (website), the

total food production in the Sahel has grown from 1961 to 1996 but this has been far much less than the population growth that has doubled over the same period thus, causing per capita food production to decline substantially.

Presently, traditional practices used by farmers are no longer productive (unsustainable and destructive to the environment) causing soil depletion and demanding more land (Stoorvogel and Smaling 1990). Farmers do not use external inputs, crop residue is removed from the fields every year and inadequate farming systems such as continuous cropping were used. Then land

is degraded through erosion causing soil and nutrient loss from the topsoil containing organic matter and more nutrients. Soil loss of $190 \text{ t ha}^{-1} \text{ year}^{-1}$ has been measured on bare plots (Buerkert et al. 1996). There is therefore a need to change these traditional ways by adopting some long-term soil fertility management practices to increase food production.

Results of the last 5 years from a long-term trial started in 1986 will be presented to show the effect of phosphorus, nitrogen and organic matter management for sustainable land use in western zone of Niger. The effect of cropping systems such as rotation on soil fertility will also be discussed. The results demonstrate that introducing legume as cash crop can solve farmers' capacity to buy fertilizers.

Apart from increasing succeeding cereal yields, rotation system has other benefits effects such as crop-livestock integration in Sudano-Sahelian zone. Increasing the legume component in the cropping system will not only improve the soil conditions for the succeeding cereal crop, but will provide good quality livestock feed, manure production for organic amendments of the soils and also cash provision to ameliorate farmers livelihood and their capacity to buy fertilizers.

Materials and methods

The trial covers an area of over four hectares piece of land so that plots could be representative of a farm level. Four replications were made each with 14 plots. Plot dimensions were $50\text{m} \times 10\text{m}$ and planted at the recommended density of $10,000 \text{ plants ha}^{-1}$ for pure millet and $40,000 \text{ plants ha}^{-1}$ for pure cowpea. A plot was included to represent farmer's traditional farming practice. Association plots were planted with $10,000 \text{ plants ha}^{-1}$ for millet plus $5,000 \text{ plants}$ for cowpea. No difference was made on phosphorus application; each plot received the recommended rate of 13 kg P ha^{-1} except the traditional (control) plot but each plot was divided into two parts with one part receiving crop residue and the other part left untreated. Each sub-plot was divided again in two parts with application of nitrogen on one sub-sub-plot and no nitrogen on the second. Half of the previous year crop residue produced was applied on the part of the plot treated and nitrogen was applied at 30 kg N ha^{-1} in two times of 15 kg . Among these 14 plots we have 9 main treatments, which included 5 intercrops (1–2–3–4–5) and 4 pure crops (6–7–8–9). An additional control (traditional) was added with local variety to be compared

Table 1. Main treatments of different plots in OPSCAR trial

Plot No	Treatment No	Fertilizer	Animal traction	Hand cultivation	Rotation
1	1	No	No	Yes	No
2	2	Yes	Yes	No	No
3	3	Yes	Yes	No	Yes
4	3	Yes	Yes	No	Yes
5	4	Yes	No	Yes	No
6	5	Yes	No	Yes	Yes
7	5	Yes	No	Yes	Yes
8	6	Yes	Yes	No	No
9	7	Yes	Yes	No	Yes
10	7	Yes	Yes	No	Yes
11	8	Yes	No	Yes	No
12	9	Yes	No	Yes	Yes
13	9	Yes	No	Yes	Yes
14	10	No	No	Yes	No

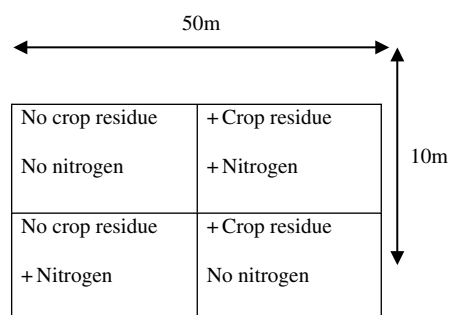

Figure 1. Subdivision of the main plot into four sub-sub-plots.

with the first one where improved variety was used (treatment 10). Treatments (3–5–7–9) were doubled to yield millet and cowpea the same year on 2 rotational plots for each treatment where rotation was used. Table 1 shows the plots and main treatments while Figure 1 shows how plots were subdivided. Data were collected while harvesting, millet panicle, grain and Stover were weighted and yields calculated. MSTAT was used to analyze data and table of ANOVA for interpretations.

Results and discussions

Management of Nitrogen

Nitrogen alone is not significant and it account only for 4% in the total variation, millet grain yield for the control plot was 79 kg ha^{-1} and it was only 107 kg ha^{-1} for a sole addition of 30 kg N ha^{-1} but the yield increased to 210 kg ha^{-1} when crop residue is added and to $1,012 \text{ kg ha}^{-1}$ if P is added to the combination

Table 2. Effect of fertilizers, soil tillage, crop residue, cropping system on pearl millet grain yield; Sadore 1998–2003 cropping seasons

Treatments	Pure millet grain yield (kg.ha ⁻¹)							
	– Rotation				+ Rotation			
	– Crop residue		+ Crop residue		– Crop residue		+ Crop residue	
	–N	+N	–N	+N	–N	+N	–N	+N
Traditional	79	107	142	210				
Phosphorus + HC	445	734	681	1012	709	931	1077	1267
Phosphorus + AT	458	654	628	858	768	965	1016	1199

HC: hand cultivation, planting on flat; AT: Animal traction, planting on ridges.

(Table 2). It is clear enough that the effect of nitrogen is linked to P application and better with a combination of P and organic fertilizer. Christianson and Vlek (1991) used data from long-term experiment from the Sudano-Sahelian Zone to develop response function to N by pearl millet and sorghum and found that the optimum rate is 50 kg N ha⁻¹ for sorghum and 30 kg N ha⁻¹ for pearl millet. At these N rates the returns were 20 kg grain per kg N for sorghum and 9 kg grain per kg N for pearl millet.

Mughogho et al. (1986) found significant relationships between crop yields and N recovery. N losses averaged 20% in the humid and sub-humid zones with maize and were significantly less than the average loss of 40% found over all treatments in the Sudano-Sahelian zone. Bationo and Vlek (1998) reported that in the Sahelian zone, nitrogen use efficiencies (NUE) were 14% in plots without lime and phosphorus whereas this amount increased to 28% when P and lime were applied. Rotation of cereals with legumes could be a way to increase NUE: from 20% in the continuous cultivation of pearl millet to 28% when pearl millet was rotated with cowpea.

Phosphorus management

In the case studied millet grain yield did not increase with addition of nitrogen (79 to 107 kg ha⁻¹) but when phosphorus was added the yields increased significantly from 445 to 734 kg ha⁻¹ (Table 2). The crop biomass also follows the same trend with P application (Table 3). The data in Table 2 indicates that from 1998 to 2003 the average control plot was 79 kg grain ha⁻¹. The sole addition of 30 kg P₂O₅ ha⁻¹ without N fertilizers increased the average yield to 445 kg ha⁻¹. The addition of only 30 kg N ha⁻¹ did not increase the yield significantly over the control and the average grain yield obtained was 107 kg ha⁻¹. It is now accepted that the replenishment of soil capital phosphorus is not only a crop production issue, but an environmental issue and P application is essential for the conservation of the natural resource base. The data further suggests that when P is applied the response to N can be substantial and with the application of 30 kg N ha⁻¹ a pearl millet grain yield of 734 kg ha⁻¹ was obtained as compared to 445 kg ha⁻¹ when only P fertilizers were applied. This data clearly indicates that P is the most limiting factor

Table 3. Effect of fertilizers, soil tillage, crop residue, cropping system on pearl millet TDM yield; Sadore 1998–2003 cropping seasons

Treatments	Pure millet TDM yield (kg.ha ⁻¹)							
	– Rotation				+ Rotation			
	– Crop residue		+ Crop residue		– Crop residue		+ Crop residue	
	–N	+N	–N	+N	–N	+N	–N	+N
Traditional	641	962	987	1331				
Phosphorus + HC	2281	3224	3150	4296	3264	3970	4608	5459
Phosphorus + AT	2138	2932	2903	3927	3443	4452	4615	5565

HC: hand cultivation, planting on flat; AT: Animal traction, planting on ridges.

Table 4. Effect of fertilizers, soil tillage, crop residue, cropping system on cowpea fodder yield; Sadore 1998–2003 cropping seasons

Treatments	Cowpea fodder yield (kg ha ⁻¹)							
	– Rotation				+ Rotation			
	– Crop residue		+ Crop residue		– Crop residue		+ Crop residue	
	–N	+N	–N	+N	–N	+N	–N	+N
Traditional	293	519	503	530				
Phosphorus + HC					1051	1224	1105	1267
Phosphorus + AT					764	888	914	1091

HC: hand cultivation, planting on flat; AT: Animal traction, planting on ridges.

in those sandy Sahelian soils and there is no significant response to N without correcting first for P deficiency.

Phosphorus is the most limiting factor to crop production in the sandy soils of Sahelian zone. Available P in these soils is very low less than 2 mg P kg⁻¹. Manu et al. (1991) on a fertility study found that the amount of total P in these soils ranged from 25 to 340 mg kg⁻¹ with a mean of 109 mg kg⁻¹. The low content of both total and available P parameters may be related to several factors such as parent materials, form in the soil and low level of organic matter. About 80% of the soils in sub-Saharan Africa are short of this critical nutrient element and without the use of phosphorus, other inputs and technologies are not effective.

The soils of the Soudano-Sahelian zone have very low capacity to fix P (Sanchez and Uehara 1980). P sorption maximum was determined using the method of Fox and Kamprath (1970) and the values of maximum P sorbed ranged from 27 mg kg⁻¹ to 253 mg kg⁻¹ with a mean of 94 mg kg⁻¹. Phosphorus deficiency is a major constraint to crop production and response to nitrogen is substantial only when both moisture and phosphorus are not limiting.

In this long-term soil management trials, crop residue and ridging and rotation of pearl millet with

cowpea were also evaluated to determine their effect on Phosphorus Use Efficiency (PUE). The results showed that productivity of the sandy soils can be increased significantly with the adoption of improved crop and cropping systems, whereas the absolute control recorded 79 kg ha⁻¹ of pearl millet grain; 1,267 kg ha⁻¹ was obtained when phosphorus nitrogen and crop residue were applied and followed leguminous cowpea upon the previous season. Results indicated that for the total dry matter yield PUE increases from 126 with only P application to 228 when P is applied in combination with nitrogen, crop residue and to 318 in a rotation system (Table 6) cowpea fodder production was increased to 1267 kg/ha in the rotation system (Table 4) while the grain production was low and variable with an highest yield of only 213 kg/ha (Table 5). But the high value of cowpea products (Table 6) and its role in soil fertility through rotation play a lot in the promotion of cowpea crop in the promotion of cowpea crop in the system. In these sandy soils, ridge has no significant effect on grain production but a very small effect on biomass. Its effect can be observed early on development of crops and during poor rainfall year at the beginning of the raining season when wind erosion can reduce crop growth.

Table 5. Effect of fertilizers, soil tillage, crop residue, cropping system on cowpea grain yield; Sadore 1998–2003 cropping seasons

Treatments	Cowpea grain yield (kg ha ⁻¹)							
	– Rotation				+ Rotation			
	– Crop residue		+ Crop residue		– Crop residue		+ Crop residue	
	–N	+N	–N	+N	–N	+N	–N	+N
Traditional	37	39	43	39				
Phosphorus + HC					199	172	150	164
Phosphorus + AT					181	154	196	213

HC: hand cultivation, planting on flat; AT: Animal traction, planting on ridges.

Table 6. Total price of cowpea products compared to fertilizer used price in rotation system; Sadore 1998–2003 cropping seasons

Treatment	Yield/Prices	– Rotation				+ Rotation			
		– Crop residue		+ Crop residue		– Crop residue		+ Crop residue	
		–N	+N	–N	+N	–N	+N	–N	+N
Traditional	Grain yield	37	39	43	39				
	Fodder yield	293	519	503	530				
	Fertilizer used	0	0	0	0				
	Grain price	8325	8775	9675	8775				
	Fodder price	8790	15570	15090	15900				
	Total price	17115	24345	24765	24675				
	Fertilizer price	0	0	0	0				
	Benefits	17115	24345	24765	24675				
Phosphorus + HC	Grain yield					199	172	150	164
	Fodder yield					1051	1224	1105	1267
	Fertilizer used					167	232	167	232
	Grain price					44775	38700	33750	36900
	Fodder price					31530	36720	33150	38010
	Total price					76305	75420	66900	74910
	Fertilizer price					16700	23200	16700	23200
	Benefits					59605	52220	50200	51710
Phosphorus + AT	Grain yield					181	154	196	213
	Fodder yield					764	888	914	1091
	Fertilizer used					167	232	167	232
	Grain price					40725	34650	44100	47925
	Fodder price					22920	26640	27420	32730
	Total price					63645	61290	71520	80655
	Fertilizer price					16700	23200	16700	23200
	Benefits					46945	38090	54820	57455

HC: hand cultivation, planting on flat; AT: Animal traction, planting on ridges; Fertilizer: 100F cfa.kg⁻¹, cowpea grain: 225F cfa.kg⁻¹, cowpea fodder: 30F cfa.kg⁻¹.

Crop residues as organic matter

The PUE for millet TDM increased from 126 to 146 with application of crop residue and to 228 when crop residue was combined with nitrogen (Table 7). In the

Sahelian zone a very significant effect between crop residue and mineral fertilizer was reported (Bakayoko et al. 2000). From a long-term experiment started since 1984 Bationo et al. (1993) found that grain yield declined to 160 kg ha⁻¹ in unmulched and unfertilized

Table 7. Effect of fertilizers, soil tillage, crop residue, rotation on pearl millet TDM yield and PUE (phosphorus use efficiency); Sadore 1998–2003 cropping seasons

Treatments	Pure millet TDM yield (kg.ha ⁻¹)															
	– Rotation						+ Rotation									
	– Crop residue			+ Crop residue			– Crop residue			+ Crop residue						
	–N	+N	–N	+N	–N	+N	–N	+N	–N	+N	–N	+N				
	yield	PUE	yield	PUE	yield	PUE	yield	PUE	yield	PUE	yield	PUE				
Traditional	641	962	987	1331												
Phosphorus + HC	2281	126	3224	174	3150	166	4296	228	3264	202	3970	231	4608	279	5459	318
Phosphorus + AT	2138	115	2932	152	2903	147	3927	200	3443	216	4452	268	4615	279	5565	326

HC: hand cultivation, planting on flat; AT: Animal traction, planting on ridges.

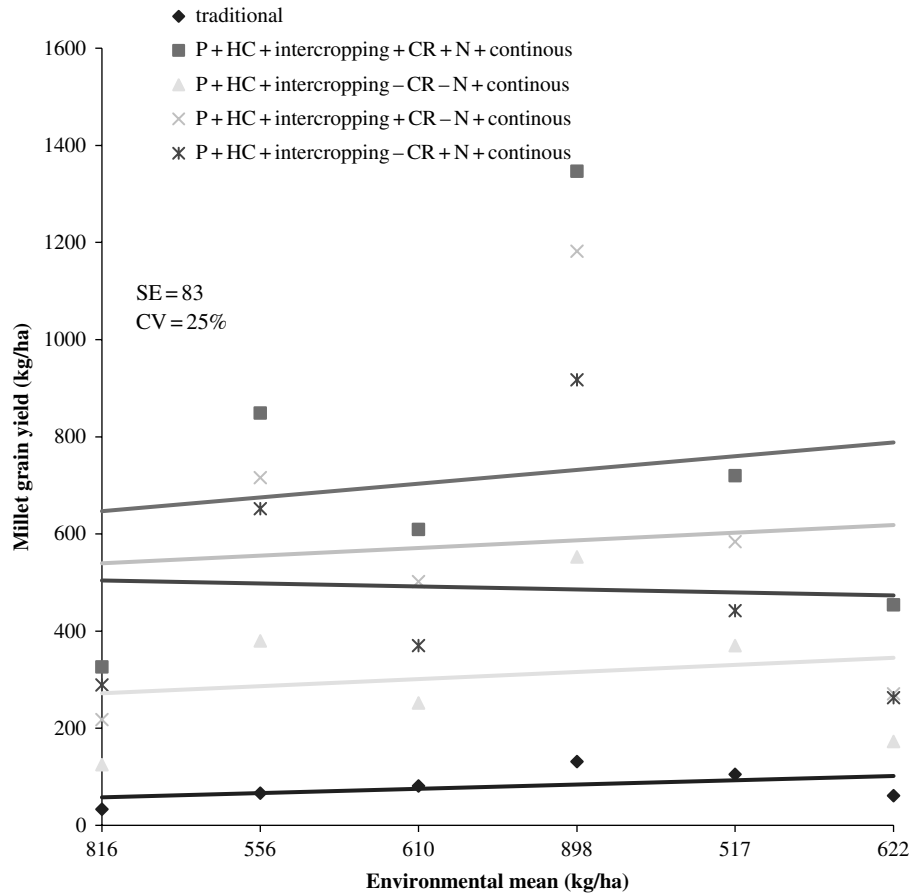

Figure 2. Long term effect of fertilizer, CR and cropping system on pearl millet grain yield, Sadore, 1998–2003.

plots. However, grain yield could be increased to 770 kg ha⁻¹ with a mulch of 2 t crop residues per hectare and 1,030 kg ha⁻¹ with 13 kg P plus 30 kg N ha⁻¹. The combination of crop residue and mineral fertilizers resulted in grain yield of 1,940 kg ha⁻¹. The application of crop residue can maintain soil organic carbon in the topsoil but continuous cultivation without mulching can reduce it. In the Sudanian zone, many reports have shown the effect of crop residue used as organic amendment (Bationo et al. 1995). Its application result in increasing soil pH, and exchangeable bases and decreased the capacity of the soil to fix phosphorus.

The data in Figures 2 and 3 clearly indicate the advantages of using crop residues both on pearl millet grain and total dry matter.

Soil organic matter is important for sustainable land use management resulting to retention and storage of nutrients, and increasing water holding capacity.

Bationo et al. (1995) reported that continuous cultivation in the Sahelian zone has led to drastic reduction in organic matter and a subsequent soil acidification. Bationo and Mokwunye (1991) reported that in the Sudano-Sahelian zone, the effective cation exchange capacity (ECEC) is more related to organic matter than to clay, indicating that a decrease in organic matter will decrease the ECEC and subsequently the nutrient holding capacity of these soils. De Ridder and van Keulen 1990 found that a difference of 1 g kg⁻¹ in organic carbon results in a difference of 4.3 mol kg⁻¹. In many cropping systems few if any agricultural residues are returned to the soil. This leads to decline soil organic matter, which frequently results in lower crop yields or soil productivity.

The soils of the Sudano-Sahelian zone are inherently low in organic carbon. The concentration of organic carbon in their top soil is reported to average 2 mg kg⁻¹. This is due to the low root growth

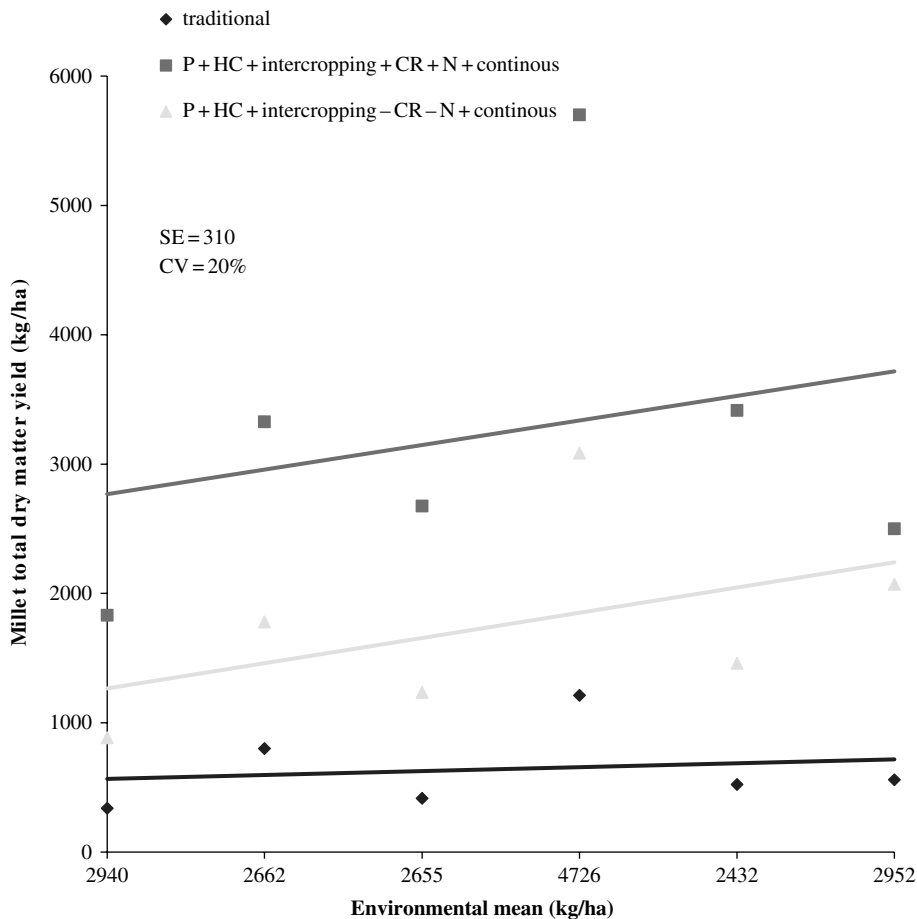

Figure 3. Long term effect of fertilizer, CR and cropping system on pearl millet total dry matter yield, Sadore, 1998–2003.

of crops and natural vegetation but also the rapid turnover rates of organic materials with high soil temperature and microfauna, particularly termites. Manu et al 1991 found in millet producing soils, an average soil Corg content of 7.6 g kg^{-1} with a range from 0.8 to 29.4 g kg^{-1} .

Soil management can have some effects the organic carbon contents. Bationo et al. 1995 found an evidence for rapid decline of organic carbone (Corg) levels with continuous cultivation of crops in the Sudano-Sahelian zone. It was also demonstrated that soil erosion can increase Corg losses from 2% to 6.3%. To prevent these losses, there is a need to practice some soil managements such as crop rotation, application of mineral fertilizers and mulching. Soil tillage will also have a significant effect on annual losses of Corg and more significant if combined to those managements.

Combining N, P and crop residue in production

Whereas treatments, meaning P accounted for 43% of the total variation, nitrogen accounted for 4% in the total variation indicating that P is the most limiting factors at this long-term trial. Crop residue accounted for 8% in the total variation. The sole addition of crop residue without N and P increased yield from 79 to $142 \text{ kg grain ha}^{-1}$. N increased this yield from 142 to 210 kg ha^{-1} and when P was combined with both N and crop residue, the yields increased to $1,012 \text{ kg ha}^{-1}$. So if millet can be rotated with cowpea, high grain production can achieved $1,267 \text{ kg ha}^{-1}$ (Table 2).

The data in Table 3 clearly indicate the comparative advantage to combine organic and inorganic plant nutrients in the Sahel soils. A combination of crop residue, P and N achieved more yield as compared to crop residue alone. The biomass can be increased

Table 8. Effect of fertilizers, soil tillage, crop residue, intercropping on pearl millet grain and TDM yield and PUE (phosphorus use efficiency); Sadore 1998–2003 cropping seasons

Treatments	Millet grain and TDM yield (kg.ha ⁻¹)															
	grain								TDM							
	– Crop residue				+ Crop residue				– Crop residue				+ Crop residue			
	–N		+N		–N		+N		–N		+N		–N		+N	
	yield	PUE	yield	PUE	yield	PUE	yield	PUE	yield	PUE	yield	PUE	yield	PUE	yield	PUE
Traditional	79		107		142		210		641		962		987		1331	
Phosphorus + HC	309	18	489	29	579	34	717	39	1753	86	2142	91	2659	129	3242	147
Phosphorus + AT	455	29	584	37	620	37	779	44	1989	104	2430	113	2632	127	3274	149

HC: hand cultivation, planting on flat; AT: Animal traction, planting on ridges.

up to 4,296 kg ha⁻¹ and 5,565 kg ha⁻¹ when rotation was used. Combining organic resources and mineral inputs is one of the best ways of the Integrated Soil Fertility Management approach. It's also an issue to the availability of the crop residue for the next year.

Millet-cowpea intercropping

PUE is lower in the intercropping system with a range from 86 to 149 kg TDM kg⁻¹ P whereas rotation gives a range from 202 to 326 (Tables 7 and 8). In our experiment trial, continuous intercropping either on

Table 9. Total price of cowpea products compared to fertilizer used price in intercropping system; Sadore 1998–2003 cropping seasons

		– Crop residue				+ Crop residue			
		–N		+N		–N		+N	
Traditional	Grain yield	37		39		43		39	
	Fodder yield	293		519		503		530	
	Fertilizer used	0		0		0		0	
	Grain price	8325		8775		9675		8775	
	Fodder price	8790		15570		15090		15900	
	Total price	17115		24345		24765		24675	
	Fertilizer price	0		0		0		0	
	Benefits	17115		24345		24765		24675	
Phosphorus + HC	Grain yield	69		76		51		54	
	Fodder yield	333		496		449		504	
	Fertilizer used	167		232		167		232	
	Grain price	15525		17100		11475		12150	
	Fodder price	9990		14880		13470		15120	
	Total price	25515		31980		24945		27270	
	Fertilizer price	16700		23200		16700		23200	
	Benefits	8815		8780		8245		4070	
Phosphorus + AT	Grain yield	43		40		43		48	
	Fodder yield	262		252		357		395	
	Fertilizer used	167		232		167		232	
	Grain price	9675		9000		9675		10800	
	Fodder price	7860		7560		10710		11850	
	Total price	17535		16560		20385		22650	
	Fertilizer price	16700		23200		16700		23200	
	Benefits	835		–6640		3685		–550	

HC: hand cultivation, planting on flat; AT: Animal traction, planting on ridges. Fertilizer: 100F cfa.kg⁻¹, cowpea grain: 225F cfa.kg⁻¹, cowpea fodder: 30F cfa.kg⁻¹.

flat or ridge plot produce less millet and cowpea than rotation and cowpea production cannot support fertilizer needed. The benefit is higher for traditional with an average of 22,725 F cfa ha⁻¹ while only an average of 7,477 F cfa ha⁻¹ on flat plot and negative 668 F cfa ha⁻¹ on ridge plot can be gained (Table 9). Fussell and Serafini (1985) reported yield advantages from 10–100% in millet-cowpea systems. Farmers seem to prefer intercropping because they believe to its yield stability in both good and poor rainfall years whereas rotation has best production only when rainfall is good Ntare (1989) reported yield advantages of 20–70% depending on the different combinations of pearl millet and cowpea cultivars. Traditional intercropping cover over 75% of the cultivated area in the Sudano-Sahelian zone, but the use and efficiency of fertilizers under these systems is not clear enough. The growth of these crops is rapid under P application and then competition between cereal and legume depend on their planting date; one can significantly reduce the yield of the other.

Crop rotation

The study demonstrates that including a combination of rotation, inorganic and organic nutrient sources have high potential in increasing pearl millet grain yields in the very poor Sahelian soils (Tables 2 and 3) and also millet biomass and cowpea fodder yields (Tables 4 and 5). Farmers can gain only an average benefit of 22,725 F cfa ha⁻¹ from cowpea in the traditional way. This benefit can reach an average of 53,434 F cfa.ha⁻¹ on flat plot and 49,328 F cfa.ha⁻¹ on ridged plot (Table 6). It's clear that more benefits are possible with rotation system compared to the traditional and intercropping systems both on millet and cowpea. Despite the recognized need to apply chemical fertilizers for high yields, the use of fertilizers in West Africa is limited mainly by lack of capital and other socio-economic factors. Cheaper means of improving soil fertility and productivity are therefore necessary.

Nitrogen-15 (¹⁵N) has been used to quantify the amounts of nitrogen fixed by cowpea under different soil fertility levels showed that nitrogen derived from the air (Ndfa) varies from 65 to 88% and can reach 89 kg N ha⁻¹ in the complete treatment where all nutrients were applied. In a comparison of different cropping systems, it have been shown that nitrogen use efficiency increased from 20% in continuous pearl millet cultivation to 28% when pearl millet was rotated

with cowpea (Bationo et al. 1998). It is clear that although the above ground biomass of the legume will be used to feed livestock and not returned to the soil, rotation will increase not only the yields of succeeding cereal crop but also its nitrogen use efficiency. The different cropping systems have a significant effect on the soil organic carbon, which levels, was 0.22% in the continuous systems whereas it increased to 0.27% in the rotation systems. As a result of this, soil pH was higher in the rotation systems as compared to the continuous millet systems.

Conclusion

The use of rotation, organic and inorganic nutrients is a good way to conduct research with small-scale farmers. But this research may be developed in a judicious way to be compatible to farmer's needs and possibilities. Its efficiency can for example be increased by reduction of nutrient losses through erosion, increasing biomass production on the farms for domestic use, livestock feeds and for soil mulching in a cycle of sustainable land use. The resource poor farmers have adopted few of the technologies proposed by researchers to address land degradation because of their capacity to invest in onerous soil fertility managements and others socio-economics factors. To be adopted researchers have to test their technologies in a participatory approach with land users. It is also important to combine rainwater and nutrient managements because in the Sudano-Sahelian zone, erratic rainfall, its distribution in space and time and runoff-susceptible land are the main problems that have to be addressed for crop production. Some water conservation and water harvesting techniques have to be combined to organic and inorganic amendments to secure agricultural production and reduce farmer's financial risks of purchasing fertilizers. Ridging is one of these techniques although it is significant only in poor rainfall years. Another important future research opportunity is the selection of genotypes that can be efficient for better utilization of P applied. Farmers seem to prefer their local variety and a comparison of the two traditional plots with improved variety (treatment 1 = 134 kg grain ha⁻¹) and local variety (treatment 10 = 303 kg grain ha⁻¹) confirmed their choice. Under P treatment, the result is the same confirmed by other experiments. But in some years with short rainfall period, the long cycle to maturity causes some problems on the local variety.

References

- Bakayoko M., Buerkert A., Lung A., Bationo A. and Romheld V. 2000. Cereal/legume rotation effects on cereal growth in Sudano-Sahelian West Africa: soil mineral nitrogen, mycorrhizae and nematodes. *Plant and Soil* 218: 103–116.
- Bationo A. and Mokwunye A.U. 1991. Role of manures and crop residues in alleviating soil fertility constraints to crop production with special reference to the Sahelian zones of West Africa. *Fertilizer Research* 29: 125–177.
- Bationo A. and Vlek P.L.G. 1998. The role of nitrogen fertilizers applied to food crops in the Sudano-Sahelian zone of West Africa. In: Renard G., Neef A., Becker K. and von Oppen M. (eds). *Soil Fertility Management in West African Land Use Systems*. Margraf Verlag, Weikersheim, Germany, pp. 41–51.
- Bationo A., Buerkert A., Sedogo M.P., Christianson B.C. and Mokwunye A.U. 1995. A critical review of crop residue use as soil amendment in the West African Semi-Arid Tropics. In: Powell J.M., Fernandez-Rivera S., Williams T.O. and Renard C. (ds). *Livestock and Sustainable Nutrient Cycling in Mixed Farming Systems of Sub-Saharan Africa*, pp. 305–322. Volume 2: Technical Papers. Proceedings of an International Conference, 22–26 November 1993. International Livestock Centre for Africa (ILCA), Addis Ababa, Ethiopia.
- Bationo A., Christianson B.C. and Klaj M.C. 1993. The effect of crop residue and fertiliser use on pearl millet yields in Niger. *Fertilizer Research* 34: 251–258.
- Bationo A., Ndjeunga J., Biolders C., Prabhakar V.R., Buerkert A. and Koala S. 1998. Soil fertility restoration options to enhance pearl millet productivity on sandy sahelian soils in south-west Niger. In: Peter Lawrence, Geneviève Renard and Matthias von Oppen (eds). *The Evaluation of Technical and Institutional Options for Small Farmers in West Africa*. Proceedings of an International Workshop held on April 21–22–1998 at the University of Hohenheim as part of the Special Research Program 308. Adapted Farming in West Africa. Margraf Verlag, Weikersheim, Germany.
- Buerkert A., Lamers J.P.A., Marschner H. and Bationo A. 1996. Inputs of mineral nutrients and crop residue mulch reduce wind erosion effects on millet in the Sahel. In: Buerkert B., Allison B.E. and von Oppen M. (eds). *Wind Erosion in West Africa*. The problem and its control. Proc. Intern. Symp., Univ. Hohenheim, Stuttgart, Germany, 5–7 December 1994. pp. 145–160.
- Christianson C.B. and Vlek P.L.G. 1991. Alleviating soil fertility constraints to food production in West Africa: Efficiency of nitrogen fertilizers applied to food crops. In Mokwunye A.U. (ed.). *Alleviating soil fertility constraints to increased crop production in West Africa*. Kluwer Academic Publishers, Dordrecht, The Netherlands.
- De Ridder N. and van Keulen H. 1990. Some aspects of soil organic matter in sustainable intensified arable farming systems of West African semiarid tropics. *Fertilizer Research* 26: 299–310.
- FAO: www.fao.org/faostat/foodsecurity.
- Fox R.L. and Kamprath E.J. 1970. Phosphate sorption isotherms for evaluating the phosphate requirements of soils. *Soil Sci. Soc. Am. Proc.* 34: 902–907.
- Fussell L.K. and Serafini P.G. 1985. Associations de cultures dans les zones tropicales semi-arides d'Afrique de l'Ouest: stratégies de recherche antérieures et futures. (In Fr) pp. 254–278 in *Technologies appropriées pour les paysans des zones semi-arides de l'Afrique de l'Ouest* (Ohm H.W. and Nagy J.G. eds). West Lafayette, Indiana, USA: Purdue University.
- Manu A., Bationo A. and Geiger S.C. 1991. Fertility status of selected millet producing soils of West Africa with emphasis on phosphorus. *Soil Sci.* 152: 315–320.
- Mughogho S.K., Bationo A., Christianson C.B. and Vlek P.L.G. 1986. Management of nitrogen fertilizers for tropical African soils. In: Mokwunye A.U. and Vlek P.L.G. (eds). *Management of nitrogen and phosphorus fertilizers in sub-Saharan Africa*, Martinus Nijhoff, Dordrecht, The Netherlands.
- Ntare B.R. 1989. Intercropping morphologically different cowpea with pearl millet in a short season environment in the Sahel. *Experimental Agriculture* 26: 41–47.
- UNDP 1999. *Rapport national sur le développement humain, Niger*.
- Sanchez P.A. and Uehara G. 1980. Management considerations for acid soils with high phosphorus fixation capacity. In: *The role of phosphorus in agriculture*. F.E. Khasawneh (ed.). Am. Soc. Agron., Madison, WI, pp. 471–509.
- Stoorvogel J.J. and Smaling E.M.A. 1990. Assessment of soil nutrient depletion in sub-Saharan Africa: 1983–2000. Volume 1. Main report. The Winand Staring Centre, Wageningen, The Netherlands.

Biological system for improving the availability of Tilemsi phosphate rock for wheat (*Triticum aestivum* L.) cultivated in Mali*

A.H. Babana^{1,2} and H. Antoun^{2,*}

¹Faculté des Sciences et Techniques, Université du Mali, 3206 Bamako, Mali; ²Département des Sols et de Génie Agroalimentaire, Faculté des Sciences de l'Agriculture et de l'Alimentation, Pavillon Charles-Eugène Marchand, Université Laval, Québec Qc, Canada G1K 7P4; *Author for correspondence (e-mail: antoun@rsvs.ulaval.ca; phone: +1-418-656-2131, ext. 3650; fax: +1-418-656-7176)

Key words: *Aspergillus awamori*, Mycorrhiza helper bacteria, *Penicillium chrysogenum*, Phosphate solubilizing microorganisms, Plant growth promotion, *Pseudomonas* sp.

Abstract

The Tilemsi phosphate rock (TPR) of Mali is a good and cheaper alternative to imported phosphate fertilizers. Many soil microorganisms can also mobilize sparingly soluble inorganic phosphates, and several have a good potential to improve plant growth. With the aim of improving the response of wheat cultivated in Mali to fertilization with TPR, in this work we describe the isolation and selection from four different Malian soils of TPR-solubilizing microorganisms (TSM) with high P-mobilization activities. When the rhizosphere of three wheat cultivars (Alkama Beri, Hindi Tossom and Tetra) was used to isolate TSM, only bacterial isolates were selected. TPR-solubilizing fungi were only obtained by soil enrichment in liquid medium containing TPR as sole P source. In the rhizosphere a significant correlation was observed between the total microbial population and the number of microorganisms solubilizing TPR. No such correlation was observed in the rhizoplane. Initially 44 bacteria and 18 fungi were selected, but after 10 subcultures on agar plates and a liquid medium, only 6 bacteria and 2 fungi retained their high P solubilizing trait. A field inoculation trial was established during the growing season 2000–2001 in Koygour. Wheat cv. Tetra was inoculated with the 8 selected TSM (6 bacteria and 2 fungi) and fertilized with 30 kg ha⁻¹ P added as TPR or diammonium phosphate (DAP). The growth parameters measured were plant height at 30 and 60 days, the number of leaves per main stem at 60 days, and root and shoot dry matter yields 60 days after planting. Root colonization by indigenous arbuscular mycorrhizas (AM) was also measured in 45-day-old plants. Significant interactions were observed between TSM inoculation and P-fertilization for root colonization with AM, plant height at 30 days and root dry matter yield. The bacterial isolate *Pseudomonas* sp. BR2, which appeared to be a mycorrhiza helper bacterium, significantly enhanced wheat seedling emergence very early (5 days after planting) under field condition, and caused 128% increase in root dry matter yield. The two TPR-solubilizing fungal isolates *Aspergillus awamori* Nakazawa C1 and *Penicillium chrysogenum* Thom C13 also caused respectively 60 and 44% increases in root dry matter yields. The choice of the TSM BR2, C1 and C13 for further field trials is discussed.

*This article was previously published in Nutrient Cycling in Agroecosystems Volume 72/2 pages 147–157. The online version of the original article can be found at <http://dx.doi.org/10.1007/s10705-005-0241-7>

This article has been previously published in the journal “Nutrient Cycling in Agroecosystems” Volume 76 Issues 2–3.

Introduction

Phosphorus (P) deficiency is a major constraint to crop production in Mali and other countries in West Africa. This is due to immobilization carried out by microorganisms in P deficient soils and to the precipitation and fixation as insoluble complex minerals resulting from the binding of soluble P to aluminum and iron in acid soil or calcium in alkaline soils, depriving plants of up to 80% of soluble P added to soil (Goldstein 1986). This has forced farmers to apply 3–4 times the required amounts of P to crop plants, causing a substantial increase in production costs.

In Mali, imported P fertilizers are expensive, and the local Tilemsi phosphate rock (TPR) deposits supply the farmers with a cheaper alternative (Bationo et al. 1997). Many soil microorganisms, including bacteria and fungi, are able to mobilize sparingly soluble inorganic and organic phosphates, and they have an enormous potential in providing soil phosphates for plant growth (Richardson 2001; Gyaneshwar et al. 2002). We have recently shown that by inoculating wheat seeds with TPR-solubilizing microorganisms (TSM) in combination with a commercial isolate of the arbuscular mycorrhizal (AM) fungus *Glomus intraradices*, under field conditions in Mali it is possible to obtain wheat grain yields comparable to those produced by the expensive diammonium phosphate (DAP) fertilizer (Babana and Antoun 2005). In the present work we describe how the efficient TSM were obtained from Malian soils and selected for their potential use as plant growth promoting microorganisms for wheat cultivated in Mali.

Material and methods

Soil samples

Table 1 shows some physical and chemical characteristics of the 0–15 cm soils used to isolate the

TSM. Soils S, S1 and S2 are composite samples taken at three different sites near the phosphate mine situated northeast of Bourem in the Tilemsi Valley (16°8' N, 1°6' W). Soil S3 is a composite sample taken in a field cultivated with wheat in Koygour near Diré in the Timbuktu region (16°3' N, 3°0' W).

Enumeration and isolation of TPR-solubilizing microorganisms

Microorganisms were isolated from the rhizoplane and rhizosphere of one-month-old wheat plants (cv. Alkama beri, Hindi Tosson and Tetra), according to the method described by Scher et al. (1984) modified as follows. Glass test tubes (25 × 200 mm) were filled with sterile sand to a depth of 6 cm (35 g). Autoclaved distilled water (5 ml) was added to each tube and the sand was overlaid with 2 cm (6 g) of tested soil adjusted to 15% moisture. Wheat seeds were surface sterilized by soaking 1 min in 70% ethanol, 15 min in 6% sodium hypochlorite, followed by 10 times rinsing in sterile distilled water. One surface sterilized seed was added per tube and covered with another 2 cm (6 g) of soil. Tubes were sealed with parafilm and incubated in a growth chamber (28 °C, 4000 lux) for 4 weeks without added water. Plants were carefully removed from the tubes and all root segments in the sand were collected, weighed, and mixed gently in 9 ml of saline buffer (0.85% NaCl) and ten-fold serial dilutions were prepared to determine rhizosphere populations. The roots in the first dilution bottles were then washed with sterile buffer, and the soil was collected on a filter paper, and dried at 70 °C for 24–48 h to determine the rhizosphere soil dry weight. Washed roots were re-suspended in 90 ml of saline buffer, and shaken vigorously on a reciprocal shaker for 20 min, and serial dilutions were performed to measure microbial populations in the rhizoplane. To

Table 1. Some characteristics of the soils used to isolate the Tilemsi phosphate rock-solubilizing microorganisms.

Soil sample	Sampling site	Soil texture	PH (0.01 M CaCl ₂)	Organic matter (%)	Available elements (kg ha ⁻¹)				
					P	K	Ca	Mg	Fe
S	Tilemsi	Sandy clay loam	5.84	0.16	991	108	6670	528	159
S1	Tilemsi	Sandy clay loam	5.89	0.10	918	115	4250	561	152
S2	Tilemsi	Sandy loam	5.91	0.08	922	93.2	4149	502	153
S3	Koygour	Silty clay loam	6.37	0.17	6.27	240	803	217	43

enumerate total microorganisms in the rhizoplane or the rhizosphere of wheat, 0.1 ml of each dilution was spread on 1/10 strength TSA (Tryptic soy broth, Difco, 3 g l^{-1}) medium. TSM were enumerated on the National Botanical Research Institute's Phosphate growth medium (NBRIP; Nautiyal 1999), containing per litre of distilled water: glucose, 10 g; $\text{MgCl}_2 \cdot 6\text{H}_2\text{O}$, 5 g; $\text{MgSO}_4 \cdot 7\text{H}_2\text{O}$, 0.25 g; KCl, 0.2 g and $(\text{NH}_4)_2\text{SO}_4$, 0.1 g; agar, 15 g and the pH was adjusted to 7.0. Before use, TPR was thoroughly washed with Mehlich 3 extractant solution (Mehlich 1984), and several times with hot distilled water to remove any trace of available P, then was autoclaved and added to the sterile culture media as sole source of P at a concentration of 5 g L^{-1} (TPR-NBRIP medium).

TSM were isolated from the TPR-NBRIP plates used for enumeration. TSM were also directly isolated from soil by the following enrichment procedure. Two grams of soil were added to Erlenmeyer flasks containing 50 ml of liquid TPR-NBRIP medium. The flasks were incubated on a rotary shaker (150 rpm) in the dark at 28°C for 7 days. After serial dilution in saline buffer, bacteria were isolated on TPR-NBRIP medium supplemented with $50 \mu\text{g ml}^{-1}$ of cycloheximide to inhibit fungal growth, and fungi were isolated on the same medium supplemented with $150 \mu\text{g ml}^{-1}$ streptomycin to inhibit bacterial growth and $50 \mu\text{g ml}^{-1}$ of Rose Bengal dye to slow down fungal radial growth. The colonies surrounded by clear zones were picked and purified by serial streaking on TPR-NBRIP agar plates incubated in the dark at 28°C . TPR-solubilizing activity of the isolates was measured in agar cultures as described by Chabot et al. (1993). After screening of a large number of isolates, 6 bacteria and 2 fungi were selected for their high solubilization activity, and were used in field inoculation trials.

In order to determine if the selected microorganisms can be used in a mixed inoculum, antagonism between bacteria and fungi was measured as previously described by Gagné et al. (1985). The nutrient broth yeast extract (NBY) culture medium used contained per liter of distilled water: Difco nutrient broth, 8 g; Difco yeast extract, 2 g; glucose, 10 g; K_2HPO_4 , 2 g; KH_2PO_4 , 0.5 g; $\text{MgSO}_4 \cdot 7\text{H}_2\text{O}$, 0.2 g, agar, 20 g; pH adjusted to 7.0. An 8 mm agar plug was taken from the edge of an actively growing fungal colony and placed in the center of an NBY plate. Each plate was also

inoculated equidistantly from the center with four bacterial isolates. Control plates were not inoculated with bacteria. Plates were incubated at 28°C and observed daily for any sign of fungal growth inhibition, until the fungal growth in the control plates reached the points of bacterial inoculation. Antagonism between bacteria was evaluated by cross streaking two different bacterial isolates on the surface of NBY plates. Plates were also incubated in the dark at 28°C and observed daily for 7 days for any sign of bacterial growth inhibition. Production by the selected microorganisms of HCN (Bakker and Schippers 1987), siderophores (Milagres et al. 1999) and indoleacetic acid (Bric et al. 1991) was also measured. HCN, siderophores and indoleacetic acid production are *in vitro* characteristics frequently associated with the plant growth promotion potential of some soil microorganisms.

Phosphate rock

The TPR deposits contain between 23 and 32% of P_2O_5 and their solubility in neutral ammonium citrate is 4.2% (Bationo et al. 1997). The fine TPR powder used had the following composition (in mg g^{-1}): P, 150; Ca, 329; Al, 20; F, 29. The extractability of P from TPR determined according to Bolland and Gilkes (1997) was 16.2 mg g^{-1} in 2% citric acid and 73.4 mg g^{-1} in 2% formic acid.

Wheat cultivars

Three wheat (*Triticum aestivum* L.) cultivars were used: Tetra from Mali, 90 to 100 days cycle, adapted to the irrigated zones; Alkama Béri from Morocco, 90 to 100 days cycle, photoperiod sensitive; and Hindi Tossou from Egypt, 120 days cycle, photoperiod sensitive. Wheat seeds were obtained from the collection of the IER (Institut d'économie rurale) in Bamako, Mali.

Wheat emergence assay

The method was as described by De Freitas and Germida (1990). Six bacterial strains (BR2, BR8, BR10, B3, B22 and B27) and two fungal isolates

(C1 and C13) were selected for their superior TPR-solubilizing activity. Seeds of the cultivar Tetra were inoculated as follows. Bacteria and fungi were grown in the dark for 48 h on TSA plates at 28 °C and cells were suspended in 20 ml sterile tap water. One-hundred wheat seeds were added to each bacterial suspension and agitated on a rotary shaker (110 rpm) for 2 h at 10 °C. At sowing each seed contained approximately 10^5 bacterial cells or 10^3 fungal cells. Ten inoculated seeds were planted at 20 cm spacings on a 2 m long row. The control was wheat inoculated with an autoclaved isolate (BR2). Seeds were planted at a depth of 2 cm in the Koygour soil (soil S3). All treatments were repeated 10 times. Seedling emergence was evaluated 5, 10, 15 and 20 days after planting.

Field experiments

Experimental plots were established in Koygour (Diré 16°3' N, 3°0' W) during the 2000–2001 cropping season. A split-split plot design was used, and the main plots were phosphate fertilization with TPR or DAP applied at 30 kg P ha^{-1} , with a non-fertilized control, arranged in randomized complete blocks. The additional N added with the DAP was calculated and compensated for in all other treatments. Sub-plots were inoculated with TSM (BR2, BR8, BR10, B3, B22, B27, C1 and C13) with an uninoculated control. The main plots (P fertilization) were 8 m wide and 31 m long, divided in nine subplots (TSM) 2 m wide and 2.5 m long separated by a 1 m wide buffer zone. Sub-subplots contained 4 rows 50 cm apart. Two seeds of wheat (*Triticum aestivum* L.) cv. Tetra were planted in each row every 20 cm. Only the 2 central rows received seeds inoculated with TSM. All treatments were replicated 4 times. Seeds were surface sterilized and inoculated with a 1% carboxymethylcellulose solution containing the microorganisms, as previously described (Chabot et al. 1996). Planting was done on December 4, 2000. After emergence, plants were thinned to one every 20 cm of row. Nitrogen was applied as 50 kg N ha^{-1} urea, 2 and 7 weeks after planting which corresponded to stage 2 and stage 5 of Feekes scale (Large 1954), and a final application of 120 kg N ha^{-1} urea at stage 10.1 (11 weeks). All plots received 80 kg K ha^{-1} as KCl. The plots were irrigated 10 times during the growing season

(each of approximately $500 \text{ m}^3 \text{ ha}^{-1}$). Plant height was measured 30 and 60 days (Feekes scale 10) after planting, on 5 randomly chosen plants in the two central rows. The number of leaves on the main stem was counted 60 days after planting. Wheat was harvested February 5, 2001. Roots and shoots were separated and dried at air temperature then weighed.

AM colonization of roots

In the central rows of each sub-subplot, 3 plants randomly chosen at 45 days after planting, were carefully excavated, and their roots washed free of soil and stained, according to the ink and vinegar technique of Vierheilig et al. (1998), to measure the root length colonization by AM.

Soil and plant analysis

Soil was air-dried and sieved (2 mm), and treated with the Mehlich 3 extractant (Mehlich 1984) for the determination of available elements. Soil organic matter was estimated by the modified Walkley and Black method (McKeague 1978). Plant shoots and roots were air dried and weighed. The spectrophotometric vanado-molybdate method was used to measure P (Tandon et al. 1968). Other minerals were determined in soil extracts by atomic absorption spectrophotometry (Gaines and Mitchell 1979).

Statistical analysis

A two-factor analysis of variance (P fertilization, TSM) for each parameter was performed using the general linear models procedure of SAS (1990). Means were compared by using the Fisher protected least significance difference (LSD) test (Steel and Torrie 1980).

Results

Soils S, S1 and S2 from near the phosphate mine in the Tilemsi valley were very low in organic matter, and contained large amounts of available P. The other soil S3, which had grown wheat was collected from Koygour. It was very poor in

available P, and contained slightly more organic matter (Table 1). When the three cultivars of wheat tested in this work were cultivated in test tubes in the four soils, the rhizoplane and the rhizosphere of plants grown in soil S3 contained total and TSM microbial populations significantly higher than those found in wheat cultivated in the three other soils (Table 2). The highest total population was in the rhizoplane of wheat cultivar Alkama Beri, and the highest TSM population was in the rhizosphere of the cultivar Tetra (Table 2). In the rhizoplane TSM represented from 7% of the total microbial population as observed with Hindi Tossom to 20% as observed with Tetra. In the rhizosphere, TSM averaged 10% of the total microbial populations and the total number of microorganisms expressed as cfu g⁻¹ of dry soil was significantly correlated ($r = 0.70$, $p < 0.01$) to the number of TSM. Such a correlation was not observed in the rhizoplane for which the numbers of microorganisms were expressed as cfu g⁻¹ root dry weight.

Initially we retained 44 bacteria and 18 fungi, isolated from soil or from the rhizoplane or

rhizosphere of wheat cultivated in the different soils, because they were able to exhibit an important clarification halo on the TPR-NBRIP medium containing TPR as sole P source. After several subcultures on TPR-NBRIP solid or liquid medium, several isolates lost their capacity to solubilize TPR and were discarded. After 10 subcultures, 6 bacteria and 2 fungi retained their ability to solubilize TPR and were retained for further investigation. The two fungi C1 and C13 were isolated from soil S (Table 1). Bacterial isolates BR2 was obtained from the rhizosphere of the wheat cv. Tetra, and BR8 and BR10 from the rhizosphere of cv. Alkama Beri cultivated in soil S3. Bacteria B3 and B27 were isolated from soil S and B22 from soil S3. After 10 subcultures the bacterial isolates BR2 and B3 did not show any halo but were able to clarify the culture media underneath the colony growth. These two isolates were retained because they dissolved substantial amount of TPR in liquid media (results not shown). On TPR-NBRIP agar medium, the bacterial clarification halo ranged from 2 to 5 mm and they were 17 mm for the fungus C1 and 12 mm for C13.

Table 2. Effect of the wheat cultivars and the four soils used, on the importance of the total (bacteria, actinomycetes and fungi) and TPR-solubilizing microflora (TSM) in the rhizoplane and the rhizosphere of one-month-old wheat plants.

Wheat cultivar	Soil	Rhizoplane cfu × 10 ⁶ g ⁻¹ dry root		Rhizosphere cfu × 10 ⁶ g ⁻¹ dry soil	
		Total	TSM	Total	TSM
Alkama Beri	S	37.4 ± 1.5	9.1 ± 0.3	20.7 ± 1.6	2.5 ± 0.4
	S1	36.1 ± 1.9	9.5 ± 0.2	21.7 ± 1.3	2.8 ± 0.3
	S2	30.3 ± 2.5	8.3 ± 0.9	19.5 ± 1.9	2.0 ± 0.2
	S3	42.7 ± 0.8	17.9 ± 1.7	30.0 ± 0.3	3.5 ± 0.3
Hindi Tossom	S	36.8 ± 3.6	2.6 ± 0.4	25.2 ± 1.2	1.9 ± 0.2
	S1	35.7 ± 2.1	3.0 ± 0.3	24.8 ± 2.1	2.3 ± 0.4
	S2	23.3 ± 4.4	1.7 ± 0.3	19.3 ± 2.9	1.4 ± 0.3
	S3	39.1 ± 0.6	2.7 ± 0.6	32.0 ± 0.7	2.4 ± 0.4
Tetra	S	31.1 ± 2.3	6.0 ± 0.4	27.5 ± 1.5	2.6 ± 0.3
	S1	32.5 ± 3.4	6.2 ± 0.6	28.4 ± 1.1	3.0 ± 0.2
	S2	20.8 ± 1.7	5.2 ± 0.4	18.8 ± 3.0	2.2 ± 0.3
	S3	40.7 ± 1.6	7.6 ± 0.4	36.2 ± 0.9	3.4 ± 0.1
Effect of wheat cultivars					
	Alkama Beri	36.6 a	11.2 a	23.0 c	2.7 a
	Hindi Tossom	33.8 b	2.5 c	25.3 b	2.0 b
	Tetra	31.3 c	6.3 b	27.7 a	2.8 a
Soils effect					
	S	35.1 b	5.9 b	24.4 b	2.3 c
	S1	34.8 b	6.2 b	25.0 b	2.7 b
	S2	24.8 c	5.1 c	19.2 c	1.9 d
	S3	40.8 a	9.4 a	32.7 a	3.1 a

Values are mean ± the standard deviation from 3 replicates; cfu = colony forming units.

Within columns values followed by the same letter are not significantly different ($p < 0.05$) according to the Fisher protected LSD test.

Table 3. Effect of inoculation of the wheat cv. Tetra with the TPR-solubilizing bacteria (BR2, BR8, Br10, B3, B22 and B27) and fungi (C1 and C13) on seed emergence 5–20 days after sowing.

Inoculation treatments	Number emerged per 10 seeds			
	5 days	10 days	15 days	20 days
Control ^a	3.8 b	6.2 b	6.5 c	6.6 c
BR2	5.2 a	8.7 a	8.7 a	9.0 a
BR8	1.8 e	3.5 d	4.8 e	5.2 e
BR10	3.7 b	6.3 b	7.0 b	8.2 b
B3	3.3 c	6.3 b	6.5 c	8.0 b
B22	2.2 d	3.5 d	3.8 f	4.0 f
B27	0.0 f	1.8 e	2.8 g	3.2 g
C1	3.3 c	5.3 c	6.2 c	6.2 d
C13	3.8 b	5.3 c	5.8 d	6.2 d

^aInoculated with an autoclaved culture of the bacterial strain BR2.

Values are means of 10 replicates. Within columns values followed by the same letter are not significantly different ($p < 0.05$) according to the Fisher protected LSD test.

Seed inoculation with TSM significantly affected wheat seedling emergence under field conditions (Table 3). On average, emergence increased from 30% after 5 days to about 52% after 10 days, 58% after 15 days and 63% after 20 days. The bacterial isolate BR2 significantly increased wheat seedlings emergence as compared to the uninoculated control at all dates of measurement. Isolate B27 on the contrary significantly depressed emergence. Five days after sowing there was no seedling emergence when wheat seeds were inoculated with B27, and after 10 days only 18% of the planted seeds emerged. After 20 days seedling emergence with B27 was about half that of the uninoculated control. Fungi C1 and C13 delayed wheat seedling emergence 5 days after sowing, and although the

number of seedlings that emerged after 10, 15 and 20 days were significantly lower than those observed with the uninoculated control, they were comparable to the averages obtained with all treatments.

P-fertilization treatments of the wheat cv. Tetra significantly affected root colonization by indigenous AM fungi 45 days after planting, plant height after 30 and 60 days of growth, and shoot and root dry matter yields after 60 days growth under field conditions (Table 4). Inoculation of wheat seeds with TSM significantly affected root colonization by AM fungi, plant heights at 30 and 60 days growth and shoot and root dry matter yields (Table 4). The significant interactions between P-fertilization treatments and inoculation with TSM suggest that root colonization with AM fungi, Plant heights after 30 and 60 days of growth and root yields are affected by microbial inoculation in a different manner according to the source of P used (Table 4). For example AM root colonization of wheat inoculated with bacteria BR10 was significantly higher than that of the uninoculated control in the non fertilized plots and plots fertilized with TPR. However in plots receiving DAP, root colonization with AM was significantly lower than that of the control (Table 5). Plant height was only affected by TSM inoculation after 30 days growth when wheat was fertilized with DAP, and after 60 days when wheat was fertilized with TPR or DAP (Table 5). The highest percentage of AM root colonization was obtained with wheat inoculated with bacteria BR2 in non-fertilized plots as well as in plots fertilized with TPR or DAP (Table 5). Compared to the uninoculated control, BR2 significantly stimulated wheat plant height after 60 days growth when

Table 4. Summary from the analyses of variance for root arbuscular mycorrhizal colonization (% AM), plant height, leaves number per main stem, shoot and root dry matter yields of wheat cv. Tetra fertilized with TPR or DAP and inoculated with different TPR-solubilizing microorganisms (TSM).

Source of variations	Means squares						
	df	% AM	Plant height 30 days	Plant height 60 days	Leaves number	Shoot yield	Root yield
Main plots P	2	381.3***	824.4***	1855.5***	1 NS	3.4***	0.2***
Replications	3	1.6 NS	387.6***	4.1 NS	16.3***	0.8*	0.003 NS
Main plots error	6	3.4	118.9	71.5	2.7	0.08	0.002
Subplots TSM	8	391.7***	16.4*	364.5***	1 NS	0.7**	0.03***
P × TSM	16	131.4***	22.4***	57.5*	0.7 NS	0.1 NS	0.01***
Subplots error	72	2.1	6.8	31.5	0.6	0.2	0.002

*** ** Significant at $p < 0.05$, $p < 0.01$ and $p < 0.001$, respectively. NS = statistically not significant.

Table 5. Root colonization by indigenous arbuscular mycorrhizal fungi (AM) 45 days after planting, plant height 30 and 60 days after planting, number of leaves per main stem, shoot and root dry matter yields of the field grown wheat cv. Tetra as influenced by inoculation with TPR-solubilizing bacteria (BR2, BR8, Br10, B3, B22 and B27) and fungi (C1 and C13) and by P fertilization with TPR or DAP.

Inoculation treatments	AM (% colonization)			Plant-height (cm) 30 days			Plant-height (cm) 60 days			Number of leaves plant ⁻¹ 60 days			Shoot dry matter weight (t/ha)			Root dry matter weight (t/ha)		
	Control	TPR	DAP	Control	TPR	DAP	Control	TPR	DAP	Control	TPR	DAP	Control	TPR	DAP	Control	TPR	DAP
Uninoculated	4.5 b	3.5 d	3.5 b	39.3 a	40.0 a	44.5 b	65.0 a	67.8 d	75.1 cd	5.8 a	6.0 a	6.3 a	1.94 a	1.97 ab	2.14 a	0.26 a	0.25 e	0.26 a
BR2	9.8 a	33.5 a	5.0 a	34.1 a	40.9 a	49.3 a	71.2 a	94.6 a	90.4 a	6.3 a	6.5 a	6.3 a	2.27 a	2.98 a	3.09 a	0.25 a	0.57 a	0.39 a
BR8	0.0 c	0.5 e	1.5 bc	35.1 a	40.9 a	43.0 b	67.7 a	73.4 cd	79.5 cd	5.8 a	6.3 a	6.5 a	2.10 a	2.84 ab	2.97 a	0.29 a	0.39 b	0.33 a
BR10	7.5 a	21.8 b	1.8 b	34.9 a	38.0 a	49.3 a	67.4 a	79.9 bc	78.2 cd	5.8 a	6.0 a	6.3 a	2.19 a	2.71 ab	2.78 a	0.22 a	0.43 b	0.34 a
B3	2.3 bc	0.0 e	0.8 bc	33.5 a	40.7 a	48.3 a	65.6 a	73.9 cd	75.7 cd	6.3 a	5.0 a	6.3 a	2.29 a	2.45 ab	2.67 a	0.25 a	0.51 a	0.34 a
B22	0.0 c	8.8 c	0.0 c	34.2 a	40.1 a	42.0 b	64.5 a	76.7 bc	74.5 d	5.8 a	6.0 a	6.5 a	2.20 a	2.48 ab	2.66 a	0.27 a	0.32 cd	0.31 a
B27	0.0 c	0.0 e	0.0 c	36.3 a	40.7 a	42.6 b	66.0 a	74.3 cd	76.0 cd	6.8 a	6.5 a	6.3 a	2.10 a	2.14 b	2.92 a	0.25 a	0.26 de	0.32 a
C1	0.0 c	0.0 e	0.0 c	34.7 a	38.5 a	40.8 b	68.2 a	92.2 a	88.8 ab	6.3 a	7.3 a	7.0 a	2.41 a	2.84 ab	3.01 a	0.27 a	0.40 b	0.32 a
C13	0.0 c	0.0 e	0.0 c	34.4 a	41.1 a	43.0 b	70.1 a	82.1 b	82.3 bc	5.8 a	6.8 a	6.5 a	2.14 a	2.77 ab	2.94 a	0.24 a	0.36 bc	0.31 a

Within each column means followed by the same letter are not statistically different according to the Fisher protected Lsd test ($p < 0.05$).

TPR or DAP were added. Comparable results were obtained when wheat was inoculated with the two fungal isolates C1 and C13. The number of leaves per main stem was not affected by P-fertilization treatments or by seed inoculation treatments (Table 5).

After 60 days of growth, the shoot dry matter yields of the cv. Tetra of wheat was not influenced by inoculation with TSM in the non- or DAP fertilized plots (Table 5). When wheat was cultivated with TPR, all inoculation treatments produced similar shoot dry matter yields, however the yield obtained with BR2 was significantly higher than that of B27. All TSM inoculation treatments, except with bacteria B27, significantly stimulated root dry matter yield (Table 5). The observed increases in root dry matter yields ranged from 28% with bacteria B22 to 128% with BR2 and from 44% with the fungus C13 to 60% with C1.

In general in the presence of DAP, wheat root length colonized with indigenous AM fungi was always lower than observed in TPR amended or in the unfertilized control plots (Tables 5 and 6). For all inoculation treatments combined, P-fertilization with TPR or DAP significantly enhanced plant height after 30 or 60 days growth (Table 6). The tallest plants were observed in plots fertilized with DAP after 30 days growth, however after 60 days no significant difference was observed between plant fertilized with TPR or DAP (Table 6). Fertilization with 30 kg ha⁻¹ of P significantly stimulated shoot dry matter yield of 60-day-old wheat cv. Tetra, but DAP was a better source than TPR (Table 6). P-fertilization also

Table 6. Effect of fertilization with 30 kg P ha⁻¹ applied as TPR or DAP on wheat cv. Tetra height 30 and 60 days after planting, number of leaves per main stem, shoot and root dry matter yields.

Variables	Control	TPR	DAP
AM % colonization	2.6 b	7.6 a	1.4 c
Plant height 30 days (cm)	37.2 c	40.2 b	44.7 a
Plant height 60 days (cm)	67.3 b	79.4 a	80.0 a
Shoot number	6.03 a	6.25 a	6.4 a
Shoot yield (t/ha)	2.19 c	2.59 b	2.80 a
Root yield (t/ha)	0.26 c	0.39 a	0.33 b

Values are means of all inoculation treatments (TPR-solubilizing microorganisms).

In each line means followed by the same letter are not statistically different according to the Fisher protected Lsd test ($p < 0.05$).

stimulated root dry matter yield, however in that case TPR was a better P source than DAP.

None of the bacteria or fungi tested produced HCN or exhibited any antagonistic activity towards all other selected TSM. Bacteria BR2, BR10 and B3 produced siderophores and BR2, BR10, B3 and B22 produced indoleacetic acid or related compounds. The two fungi C1 and C13 did not produce siderophores or indoleacetic acid.

Discussion

In this work, we used two different methods to isolate TSM from the four soils collected in Mali. The first was based on the methodology developed by Scher et al. (1984) and was aimed at isolating rhizosphere competent TSM. The second method used for comparison purpose was by bulk soil enrichment. At the end of the screening procedures the effective TSM obtained from the rhizosphere of wheat were only bacteria (BR2, BR8 and BR10). Bulk soil enrichment in addition to three more TPR solubilizing bacteria (B3, B27 and B22) allowed the isolation of the two fungi C1 and C13. Bacteria are the most numerous inhabitants of the rhizosphere (Kennedy 1999) and thus direct isolation from the rhizosphere probably favored the growth of bacteria on TPR-NBRIP agar plates and reduced the chances of isolating effective phosphate solubilizing fungi. In fact, a rhizosphere competent inorganic P-solubilizing fungal isolate of *Penicillium rugulosum*, was previously isolated directly from soil (Reyes et al. 2002). As fungi produce spores, which are more resistant to adverse environmental conditions like drought or high temperature, screening for phosphate solubilizing microorganisms to be used in area subjected to such stresses should also include isolation from bulk soil.

To screen for TSM with high activity we used the improved NBRIP-medium described by Nautiyal (1999) supplemented with TPR as sole P source. All selected microorganisms were tested for TPR solubilization on agar plates as well as in liquid medium to avoid the discrepancy observed between the two methods. Many observations indicate that some phosphate solubilizing microorganisms lose this trait after several subcultures on agar plate (Rodriguez and Fraga 1999). The 6 bacteria and the 2 fungi selected here were

subjected to 10 streaking on TPR-NBRIP agar plates. The two bacterial isolates BR2 and B3 did lose the ability to produce a halo larger than the colony diameter, however they were retained because they were able to solubilize large amount of TPR in the liquid medium.

When the three wheat cultivars were grown in test tubes in the four different soils used in this study, about 8–12% of the total microbial population were TSM (Table 2). This contrast with the higher percentages (26–46%) of calcium phosphate solubilizing microorganisms previously observed in some Canadian soils (Chabot et al. 1993), and it confirms that microorganisms mobilize P better from insoluble inorganic phosphate salts than from naturally occurring phosphate rocks (Rodriguez and Fraga 1999).

A significant correlation ($r = 0.69$, $p < 0.01$) was observed between the total microbial populations numbers in the rhizosphere (expressed as cfu g⁻¹ of dry soil) and in the rhizoplane (expressed as cfu g⁻¹ of dry roots) of the three wheat cultivars. Although the total number of microorganisms was significantly correlated to the number of TSM ($r = 0.70$, $p < 0.01$) in the rhizosphere, no such correlation was observed in the rhizoplane. The laboratory techniques presently used to estimate the numbers of phosphate-solubilizing microorganisms (PSM) in plant roots are not accurate. In fact, the presence of a high number of PSM in the rhizosphere does not necessarily translate into a higher plant P uptake or a higher P concentration in shoots (Reyes et al. 2002). This can be attributed in part to the fact that organisms identified as PSM on agar plates do not necessarily have this trait *in vivo* in the rhizosphere or the rhizoplane. Gyaneshwar et al. (2002) suggested the use of buffered culture media when screening for PSM to reflect the buffering capacity of soils, and this should be tested in future large screening studies. However because of the complexity of the interactions taking place in the rhizosphere between plants, soils, microorganisms and other constituents of soil fauna (see for example: Knox et al. 2003), and as PSM can also influence plant growth by several other different mechanisms of action (Chabot et al. 1996), more global investigations are required to understand better how PSM act within a complex soil biota and why some PSM can stimulate plant growth without enhancing P uptake (De Freitas et al. 1997).

When the cv. Norstar of winter wheat was inoculated with plant growth promoting rhizobacteria (PGPR), and grown in soil in pot experiments, some isolates induced significant increases in seedling emergence rates (De Freitas and Germida 1990). In this work, inoculation of the wheat cv. Tetra with the bacterial isolate BR2 significantly enhanced seedling emergence very early (5 days) after planting. Enhancement of seedling emergence can be the result of the antagonistic activity of the introduced bacterium against some plant pathogens (De Freitas and Germida 1990), or the production of phytohormones. The four bacteria BR2, BR10, B3 and B22 produced indoleacetic acid, and three isolates BR2, BR10 and B3 produced siderophores which can specifically inhibit or reduce the growth of some fungal pathogens, however only BR2 showed the highest and the most sustained enhancement rates. This is probably linked to the ability of isolate BR2 to stimulate significantly the beneficial natural symbiosis between wheat and indigenous AM fungi. In fact regardless of the fertilization treatment applied, BR2 significantly stimulated wheat root colonization with indigenous AM fungi, and thus it can be considered as a mycorrhizal helper bacterium (Barea et al. 2002). Wheat mycorrhizal plants are more water-use efficient than non-mycorrhizal plants (Al-Karaki 1998), and mycorrhizal plants have many mechanisms that reduce the damage caused by soil-borne pathogens (Barea et al. 2002). The two fungal isolates C1 and C13 and the bacterial isolate B27 inhibited colonization by indigenous mycorrhizas 45 days after planting. These three TSM also delayed seedling emergence. However as compared to the uninoculated control, these negative observations did not influence any of the wheat growth parameters measured in this study (plant height after 30 and 60 days, shoot and root dry matter yields after 60 days). These results are comparable to those obtained by Germida and Walley (1996) during their evaluation of the effect of inoculation of spring wheat with PGPR under field conditions. They measured significant transient increases or decreases in plant shoot and root biomass and AM root colonization at different intervals but the final seed yield was not affected significantly.

Soil fertilization with 30 kg ha⁻¹ P added as TPR or DAP significantly enhanced all the parameters measured. DAP significantly stimulated plant

height 30 days after planting and shoot dry matter yields harvested 60 days after planting, and TPR stimulated root dry matter yield at harvest. With TPR root colonization with indigenous AM fungi was approximately five times more important than with DAP. This corroborates the results of Barea et al. (1980) showing that phosphate rock does not reduce the level of root infection with AM as compared to the addition of soluble P. The observed percentages of wheat root colonization by natural AM fungi present in the Koygour soil are very low. Many adverse soil conditions like elevated temperature and water stress (Entry et al. 2002) can explain this, and wheat will probably benefit from inoculation with an appropriate isolate of AM (Graham and Abbott 2000).

In Mali, soils are frequently exposed to elevated temperature and drought; therefore the use of TSM producing resistant spores will be preferable for the success of inoculation under these difficult conditions. Endospore-forming bacteria belonging to the genus *Bacillus* include PSM isolates (De Freitas et al. 1997), which will adapt to such harsh conditions. The TSM selected in this study were identified by the laboratory of Dr Carole Beaulieu at the University of Sherbrooke (Quebec, Canada) by using the Biolog systems and the sequencing of the 16S rDNA, and none of the isolated bacteria belonged to the bacilli. For this reason and because of their high TPR solubilizing activities, the two fungi C1 and C13 were retained for future investigations. Isolate C1 was identified as *Aspergillus awamori* Nakazawa, and C13 as *Penicillium chrysogenum* Thom. The bacterial isolate BR2 identified as a *Pseudomonas* sp. was also retained because it is an important mycorrhizal helper bacterium and has superior plant growth promoting activities with wheat fertilized with TPR. The two fungal isolates C1 and C13, the bacterial isolate BR2 and a commercial AM isolate of *Glomus intraradices* were used to inoculate the cv. Tetra of wheat in field plots established in Koygour during the 2001–2002 growing season (Babana and Antoun 2005). Bacteria BR2 confirmed its mycorrhizal helper trait and inoculation of wheat with *G. intraradices* significantly increased wheat grain yield and P content. The highest grain yield and P content was obtained with TPR fertilized wheat inoculated with BR2, C1 and *G. intraradices* (Babana and Antoun 2005). More field inoculation trials should be performed in

many different regions in Mali and other parts of Africa, and with other wheat cultivars, before a commercial inoculant formulation based on these beneficial TSM can be developed.

Acknowledgments

Babana, A.H. was the recipient of a doctoral fellowship from Le Program de bourses d'excellence de la Francophonie (PCBF). The authors are grateful to the following persons in Mali who helped in the logistics and the establishment of the field plots: A. Allaye and the farmers of Koygour (Diré); Oumar Bonkano Traoré, Bakara Diallo and the personnel of PACCEM Diré, the director of the IER and Anne-Marie Marcotte. Many thanks to Professor M.P. Cescas, for his continuous encouragement and support, for his valuable advices and constructive comments.

References

- Al-Karaki G.N. 1998. Benefit, cost and water-use efficiency of arbuscular mycorrhizal durum wheat grown under drought stress. *Mycorrhiza* 8: 41–45.
- Babana A.H. and Antoun H. 2005. Effect of Tilemsi phosphate rock-solubilizing microorganisms on phosphorus uptake and yield of field-grown wheat (*Triticum aestivum* L.) in Mali. *Plant Soil*: in press.
- Bakker A.W. and Schippers B. 1987. Microbial cyanide production in the rhizosphere in relation to potato yield reduction and *Pseudomonas* spp.-mediated plant growth-stimulation. *Soil Biol. Biochem.* 19: 451–457.
- Barea J.M., Escudero J.L. and Azcón-Aguilar C. 1980. Effects of introduced and indigenous VA mycorrhizal fungi on nodulation, growth and nutrition of *Medicago sativa* in phosphate-fixing soils as affected by P-fertilizers. *Plant Soil* 54: 283–296.
- Barea J.M., Azcon R. and Azcon-Aguilar C. 2002. Mycorrhizosphere interactions to improve plant fitness and soil quality. *Antonie van Leeuwenhoek* 81: 343–351.
- Bationo A., Ayuk E., Ballo D. and Koné M. 1997. Agronomic and economic evaluation of Tilemsi phosphate rock in different agroecological zones of Mali. *Nutrient cycling Agrosyst.* 48: 179–189.
- Bolland M.D.A. and Gilkes R.J. 1997. The agronomic effectiveness of reactive phosphate rocks. 2. Effect of phosphate rock reactivity. *Aust. J. Exp. Agric.* 37: 937–946.
- Bric J.M., Bostock R.M. and Silverstone S.E. 1991. Rapid in situ assay for indoleacetic acid production by bacteria immobilized on nitrocellulose membrane. *Appl. Environ. Microbiol.* 57: 535–538.
- Chabot R., Antoun H. and Cescas M.P. 1993. Stimulation de la croissance du maïs et de la laitue romaine par des microorganismes dissolvant le phosphore inorganique. *Can. J. Microbiol.* 39: 941–947.
- Chabot R., Antoun H. and Cescas M.P. 1996. Growth promotion of maize and lettuce by phosphate-solubilizing *Rhizobium leguminosarum* biovar *phaseoli*. *Plant Soil* 184: 311–321.
- De Freitas J.R. and Germida J.J. 1990. Plant growth promoting rhizobacteria for winter wheat. *Can. J. Microbiol.* 36: 264–272.
- De Freitas J.R., Banerjee M.R. and Germida J.J. 1997. Phosphate-solubilizing rhizobacteria enhance the growth and yield but not phosphorus uptake of canola (*Brassica napus* L.). *Biol. Fertil. Soils.* 24: 358–364.
- Entry J.A., Rygielwicz P.T., Watrud L.S. and Donnelly P.K. 2002. Influence of adverse soil conditions on the formation and function of arbuscular mycorrhizas. *Adv. Environ. Res.* 7: 123–138.
- Gagné S., Antoun H. and Richard C. 1985. Inhibition des champignons phytopathogènes par des bactéries isolées du sol et de la rhizosphère de légumineuses. *Can. J. Microbiol.* 31: 856–860.
- Gaines P.T. and Mitchell A.G. 1979. *Chemical methods for Soil and Plant Analysis*. University of Georgia, Coastal Plain Station, Tifton, USA, 105 pp.
- Germida J.J. and Walley F.L. 1996. Plant growth-promoting rhizobacteria alter rooting patterns and arbuscular mycorrhizal fungi colonization of field-grown spring wheat. *Biol. Fert. Soils* 23: 113–120.
- Goldstein A.H. 1986. Bacterial solubilization of mineral phosphate: historical perspective and future prospects. *Am. J. Altern. Agric.* 1: 51–57.
- Graham J.H. and Abbott L.K. 2000. Wheat responses to aggressive and non-aggressive arbuscular mycorrhizal fungi. *Plant Soil* 220: 207–218.
- Gyaneshwar P., Naresh Kumar G.L., Parekh J. and Poole P.S. 2002. Role of soil microorganisms in improving P nutrition of plants. *Plant Soil* 245: 83–93.
- Kennedy A.C. 1999. The Rhizosphere and the spermosphere. In: Sylvia D.M., Fuhrmann J.J., Hartel P.G. and Zuberer D.A. (eds), *Principles and Applications of Soil Microbiology*. Prentice Hall, Toronto, pp. 389–407.
- Knox O.G.G., Killham K., Mullins C.E. and Wilson M.J. 2003. Nematode-enhanced microbial colonization of the wheat rhizosphere. *FEMS Microbiol. Lett.* 225: 227–233.
- Large E.C. 1954. Growth stages in cereals: illustration of the Feekes scale. *Plant Pathol.* 3: 128–129.
- McKeague J.A. (ed.), 1978. *Manual of Soil Sampling and Methods of Analysis*. Canadian Soil Survey Committee Canadian Society of Soil Science, Ottawa, 223 pp.
- Mehlich A. 1984. Mehlich 3 soil test extractant: a modification of Mehlich 2 extractant. *Commun. Soil Sci. Plant Anal.* 15: 1409–1416.
- Milagres A.M.F., Machuca A. and Napoleao D. 1999. Detection of siderophore production from several fungi and bacteria by a modification of chrome azurol S (CAS) agar plate assay. *J. Microbiol. Methods* 37: 1–6.
- Nautiyal C.S. 1999. An efficient microbiological growth medium for screening phosphate solubilizing microorganisms. *FEMS Microbiol. Lett.* 170: 265–270.

- Reyes, I, Bernier L. and Antoun H. 2002. Rock phosphate solubilization and colonization of maize rhizosphere by wild and genetically modified strains of *Penicillium rugulosum*. *Microb. Ecol.* 44: 39–48.
- Richardson A.E. 2001. Prospects for using soil microorganisms to improve the acquisition of phosphorus by plants. *Aust. J. Plant Physiol.* 28: 897–906.
- Rodriguez H. and Fraga R. 1999. Phosphate solubilizing bacteria and their role in plant growth promotion. *Biotechnol. Adv.* 17: 319–339.
- SAS, Institute Inc 1990. SAS procedure guide version 6 edition. SAS Institute Inc, Car, NC, 705 pp.
- Scher F.M., Ziegler J.S. and Klopper J.W. 1984. A method for assessing the root-colonizing capacity of bacteria on maize. *Can. J. Microbiol.* 30: 151–157.
- Steel R.G.D. and Torrie J.H. 1980. Principles and procedures of statistics, a biometrical approach. MacGraw-Hill Book Co, New York.
- Tandon H.L.S., Cescas M.P. and Tyner E.H. 1968. An acid-free vanadate-molybdate reagent for the determination of total phosphorus in soils. *Soil Sci. Soc. Am. Proc.* 32: 48–51.
- Vierheilig H., Goughlan A.P., Wyss U. and Piché Y. 1998. Ink and vinegar, a simple technique for arbuscular-mycorrhizal fungi. *Appl. Environ. Microbiol.* 64: 5004–5007.

Managing manure heaps with agro-organic wastes and cover to reduce nitrogen losses during storage on smallholder farms

Gichangi E.M.¹, Karanja N.K.² and Wood C.W.³

¹Directorate of Agronomy, University of Fort Hare, Private Bag X1314 Alice, 5700, South Africa: email; s200435019@ufh.ac.za; ²Department of Soil Science, University of Nairobi, Kenya; ³Department of Agriculture and Soils, Auburn University, USA

Abstract

Livestock manure is a valuable source of plant nutrients for crop production in the Central Kenyan highlands but its quality in terms of available nitrogen (N) is low due to considerable N losses through ammonia volatilization. This study aimed at assessing the potential of agro-organic wastes to reduce N losses from manure heaps during the storage period. Three organic amendments selected from a laboratory simulation experiment were evaluated under farmers' conditions in Karura, Kiambu District for their ability to reduce N losses from cattle manure heaps. The effect of a polyethylene sheet covering of manure heaps on N retention was also determined. There were eight treatments that comprised three agro-organic amendments (maize stover, coffee pulp and sawdust) and the control. Agronomic effectiveness of the treated manure samples and N uptake by maize seedlings were evaluated in a glasshouse experiment.

Total N content of manure amended with organic materials ranged from 1.26% to 1.85%. The N in manures with organic amendments at the start and at the end of storage was significantly different ($p \leq 0.05$). Cumulative N loss ranged from 1.60 and 6.80 g kg⁻¹ depending on the type of amendment. Nitrogen lost from non-amended manure was 2.74 g kg⁻¹ with polyethylene cover and 6.80 g kg⁻¹ without the polyethylene cover, which represented 19% and 46% of the initial N respectively. Maize growth improved significantly ($p \leq 0.05$) with increasing rates of manure irrespective of the organic treatments except for manure amended with sawdust. Treatments that received the recommended rate of N at 100 kg N ha⁻¹ had significantly higher ($p \leq 0.05$) biomass of (21.55 g plant⁻¹) than the control which produced only 2.78 g plant⁻¹. Nitrogen uptake increased with increasing rates of manure and was higher ($p \leq 0.05$) with manure amended with coffee pulp. Covering manure heaps to reduce moisture loss was also beneficial in reducing N losses

Key words: Agro-organic materials, manure, nitrogen, volatilisation.

Introduction

Smallholder farmers in the Central Kenyan highlands are faced with declining crop yields resulting from low soil fertility caused by nutrient depletion through continuous harvest and insufficient return of nutrients through fertilizer or organic resources. Attempts to improve the productivity of traditional farming systems through the introduction of inorganic fertilizers have not been widely adopted in the Central Kenyan

highlands (Karanja *et al.*, 1997). This is because of the high cost of the inorganic fertilizers, poor infrastructure and insufficient knowledge on its use. Utilization of animal manures assumes great importance in this region as a way of returning some of the nutrients removed from soil back to the croplands. This is partly because of easy accessibility of the manures on these mixed farms (Karanja *et al.*, 1997; Woome *et al.*, 1998; Wamungo *et al.*, 1999). Livestock manure is a valuable source of N for crop production and as a

soil conditioner, but its quality in terms of available N is low (Murwira *et al.*, 1993; Woomeer *et al.*, 1998; Karanja *et al.*, 1997). This has been attributed to considerable N losses through ammonia (NH₃) volatilization (Al-Kanani *et al.*, 1992). Ammonia losses can be reduced through use of organic materials that impart a number of changes on the environment such as direct adsorption of NH₄⁺ and promotion of production of organic acids by the micro-organisms that lower manure pH while others might enhance microbial N immobilisation (Subair *et al.*, 1999). This study was conducted in selected small-scale farms in the Central Kenyan highlands to evaluate the effectiveness of selected organic amendments commonly found in these farms in reducing N losses from cattle manure heaps during storage under field conditions.

Materials and methods

Description of the study area

The study was conducted on farmers' fields in Karura, Kiambu District. The area is characterised by reliable, bimodal rainfall and the soils are rich, red clays, described as Humic Nitisols (Woomeer *et al.*, 1998). The natural vegetation is afro-montane forest and evergreen bushland (Murage *et al.*, 2000) that has mostly been cleared for cultivation. Farmers cultivate coffee and tea, which is marketed through co-operative societies, as well as vegetables, bananas, maize and beans for household consumption and sale through local networks. Crop residues are regarded as harvest products and are fed to livestock, which are often too few in number to accommodate the demand for manure as additions to soil (Woomeer *et al.*, 1998). Farmers maintain fewer and high quality livestock in confinement allowing maximum collection of manures that are usually stored in heaps and exposed to the loss mechanisms such as ammonia volatilization, denitrification, leaching and runoff. Farmers supplement the nutrient requirements of higher value crops with inorganic fertilizers to compensate the small quantities and low quality of the manures available in the area (Woomeer *et al.*, 1998).

Characterisation of agro-organic wastes and manure mixtures

Cattle manure was collected from cattle sheds at the University of Nairobi's Field Station. The organic

amendments included: filter mud (FM) from Muhoroni Sugar Company, sawdust (SD) by-product of timber mills, and maize stover (MS) which is the most common crop residue on farms. Other materials were wood ash (WA) which is easily obtained from traditional cooking "jikos", Ondiri peat (OP) which is a partially decomposed peat from the Kikuyu Ondiri swamps in Kiambu District, and coffee pulp (CP) a waste product from coffee factories. Samples were air-dried, homogenised and ground to pass through a 2-mm sieve and analysed. The samples were analysed for total macro-elements (N, P, K and Ca), organic carbon, NH₄⁺ and NO₃⁻, pH, CEC and moisture content. Moisture content was determined by drying the sub-samples at 65 °C for 72 hours. Manure pH was determined in 1:5 manure: water mixture using a pH meter. Exchangeable NH₄⁺ and NO₃⁻ were determined using the method described by Okalebo *et al.* (2000) and Anderson and Ingram (1993). Total N was determined by steam distillation after Kjeldal digestion (Bremner and Mulvaney, 1982) using moist samples to avoid N losses during drying and values corrected for water content. Organic C was determined by Kurmies procedure (Walinga *et al.*, 1992). Other macro-elements (P, K, Ca and Mg) were determined following the wet ashing technique (Okalebo *et al.*, 2000) and the neutral 1M NH₄OAc saturation procedure was used to determine the CEC.

Experimental design and layout

Three organic amendments selected from a simulated screening experiment under laboratory conditions, based on their ability to reduce ammonia volatilisation from cattle manure were evaluated under farmers' conditions. The effect of a polyethylene cover on N retention during manure storage was also determined. There were in total eight treatments that comprised of three organic amendments (maize stover, coffee pulp and sawdust) and non-amended (control) and were evaluated either with or without a polyethylene cover. The organic materials and fresh cattle manure were mixed thoroughly at a ratio of 1:5 (amendment: cattle manure) and were then stored in heaps with a black polyethylene sheet (gauge 1,000) lining at the bottom and at the top for covered treatments. The lining prevented nutrient leaching, runoff losses and minimized contamination of manure with the soil.

The treated manure heaps were stored for a period of 12 weeks during which samples were taken at two weeks intervals for pH and total N determination. After the storage period, 2 kg samples were taken from each heap for use in an agronomic effectiveness assessment in the glasshouse at Kabete Field Station, University of Nairobi. Surface layer soil (0–30 cm) was collected from infertile patches found in some of the farms in Karura, Kiambu District described by Murage *et al.* (1999). The soils were air-dried and 4 kg composite samples placed in clean plastic pots of 20 cm in diameter and 20 cm in height. Manure and soil subsamples were taken, dried, ground and used for nutrient determination as described by Anderson and Ingram (1993) and Okalebo *et al.* (1993). Manure was added at rates equivalent to 5, 7 and 10 t ha⁻¹ and thoroughly mixed with the soil. Three checks were also included that comprised of a recommended rate of N (100 kg N ha⁻¹ as calcium ammonium nitrate), a farmers practice (manure 7 t ha⁻¹ + 18 kg N ha⁻¹ as diammonium phosphate) and non-amended treatment. Phosphorus and potassium were applied as triple super phosphate (46% P₂O₅) and KCl (60–62% K₂O), respectively to all experimental pots at a rate equivalent to 100 kg P ha⁻¹ and 100 kg K ha⁻¹. Micronutrients (Mn, Zn, Cu, Mo, Co, Fe and B) were also applied to all pots as foliar spray after the plants had established. The treatments were laid out in a completely randomised design and replicated three times.

Maize was sown at four seeds per pot at a depth of 1.5 cm and covered with a layer of soil. The plants were thinned after establishment to two plants per pot. Tap water was added twice a week to maintain adequate soil moisture for the growing plants. Soil samples were taken four weeks after planting from each pot using a cork borer for NH₄⁺-N and NO₃⁻-N determination using micro-Kjeldal distillation method (Bremner and Mulvaney, 1982) after extraction with 2M KCl. The

available manure N was calculated using equation 1 (Goran, 2000):

$$\frac{\text{AmN}}{(\text{NmA})} = (\text{Nm} - \text{Nsc}) \times 100\% \quad (1)$$

Where AmN is the available manure N, Nm and Nsc are, respectively mineral N values for a soil manure mixture and the corresponding soil control while NmA is the amount of N applied. This method assumes that mineralization of soil organic matter is equal in all plots.

The shoots were harvested eight weeks after planting by cutting the seedlings at first node level. They were oven dried at 65 °C for 72 hours, weighed, and ground to pass through a 2 mm sieve and analysed for total N using the micro-Kjeldal method (Bremner and Mulvaney, 1982). The plant N derived from the manure was calculated using equation 2 (Kihanda and Wood, 1996).

$$\text{NpM} = \text{NpSM} - \text{NpS} \quad (2)$$

Where NpM is plant N derived from the manure, NpSM and NpS are plant N for the soil and manure and plant N in soil alone respectively.

The data obtained was subjected to analysis of variance (ANOVA) using Genstat 5 Release 3.2 (1995). Treatment means were compared using the least significant difference (LSD) (Gomez and Gomez, 1984).

Results

Chemical characteristics of manure and organic amendments

The results of the chemical characteristics of fresh manure and organic amendments that were used are presented in Tables 1 and 2. The pHs from the extracts from manure were slightly alkaline while those of

Table 1. Chemical characteristics of the agro-organic wastes and cattle manure

Organic material	pH 1:5	Na	K	Ca g kg ⁻¹	Mg	P	N %	C %	C/N ratio	Lignin/N ratio
Filter mud	7.2	1.3	20.7	43.5	33.3	8.4	1.2	19.3	17	7
Saw dust	5.2	1.7	2.1	6.5	Trace	2.2	0.1	51.3	366	231
Maize stover	7.0	2.6	69.1	8.5	16.7	8.4	0.9	41.4	49	8
Wood ash	13.6	55.7	228.9	67.5	18.3	76.3	0.1	3.7	37	23
Ondiri peat	5.1	8.7	3.8	4.0	4.2	12.4	1.4	23.5	17	21
Coffee pulp	5.6	7.4	118.5	28.5	16.7	16.4	2.0	40.1	20	7
Cattle manure	8.2	–	8.7	10.4	–	6.4	1.7	26.5	15.5	8

Table 2. Chemical characteristics of the soil used in the pot experiment

Characteristics	Content
Moisture content (%)	14.3
pH _(water) (1:2.5)	5.3
EC (dSm ⁻¹) (1:5) (25 °C)	2.2
N (%)	0.17
Extractable P (Olsen) (mg kg ⁻¹)	16.83
Exchangeable K (cmol kg ⁻¹)	3.14
Exchangeable Ca (cmol kg ⁻¹)	8.37
Exchangeable Mg (cmol kg ⁻¹)	2.44
NO ₃ N(mg kg ⁻¹)	16.26
Organic C (%)	1.23

organic amendments were slightly acidic to neutral. Sawdust and coffee pulp were slightly acidic (5.2 and 5.6 respectively) while maize stover was neutral. Total percent N in the organic amendments ranged between 0.1 and 2.0%. Sawdust had the highest organic carbon (51.2%), C: N ratio and lignin: N ratio.

Chemical characteristics of the soil used in the glasshouse pot experiment

The soil used in this experiment was collected from infertile patches present in most of the farms in the study site. The chemical characteristic of these soils is presented in Table 2. The soils contained relatively low levels of organic carbon, total N, available phosphorus and potassium.

The chemical characteristics of the manure × organic amendment, which were evaluated for their agronomic effectiveness, are presented in Table 3. The

Table 3. Chemical characteristics of amendments x manure mixtures

Amended manure type	Nutrient		C:N Ratio
	Total N ←(g kg ⁻¹)→	Organic C	
CP + C	16.88	309.13	18
CP - C	14.72	228.31	16
MA + C	11.50	239.26	21
MA - C	7.31	128.33	18
MS + C	12.10	284.14	24
MS - C	9.94	178.2	18
SD + C	11.17	372.70	33
SD - C	9.05	318.51	35

Where, CP = Coffee pulp + manure, MA = Non-amended manure, MS = Maize stover + manure SD = Sawdust + manure, +C = with polyethylene cover and -C = without polyethylene cover.

C: N ratio of the mixtures ranged from 16 to 35. Manure amended with sawdust had the highest amount of organic carbon and higher C: N ratio compared to other amendments (Table 3). Where coffee pulp was added, lowest C: N ratio was obtained.

Effect of different agro-organic amendments on nitrogen loss from manure during storage

Nitrogen content in manures amended with different agro-organic materials ranged from 1.26% to 1.85% while that of non-amended manure was 1.42% (Table 4). Manure amended with coffee pulp had the highest N content while that amended with sawdust had the lowest N level. Cumulative N lost ranged from 1.60 to 6.80 g kg⁻¹ depending on the type of amendment. Nitrogen lost from non-amended manure was the highest among the treatments and was 2.74 g kg⁻¹ with polyethylene cover and 6.80 g kg⁻¹ without polyethylene cover. The N loss was equivalent to 19.23% with cover and 46.13% without cover of the initial N respectively. Covered manures maintained high moisture content of about 68% (data not presented) throughout the storage period thus making the conditions anaerobic. N losses under this condition were minimal with the exception of non-amended cattle manure that had a substantial loss of 19.23% of the initial N content.

Effect of manure quality and rate of application on biomass production of maize seedlings

The growth of maize seedlings significantly ($P \leq 0.05$) improved as the rates of manure increased with manure

Table 4. Effect of organic amendment and polyethylene cover on the amount of nitrogen lost from the cattle manure heaps

Treatment	Cover	Total N-loss (g kg ⁻¹)	Percent N-loss
Manure/coffee pulp	+	1.60	8.68
Manure/coffee pulp	-	3.47	19.09
Non-amended manure	+	2.74	19.23
Non-amended manure	-	6.80	46.13
Manure/maize stover	+	1.23	9.22
Manure/maize stover	-	3.48	25.98
Manure/sawdust	+	1.48	11.72
Manure/sawdust	-	3.61	28.49
LSD _{0.05}		0.59	4.48
CV		11.20	12.1
S.E		0.34	2.59

amended with coffee pulp and maize stover showing the best performance (Table 5). Addition of the recommended rate of N of 100 kg N ha⁻¹ (FURP, 1994) alone gave the highest biomass of 21.6 g plant⁻¹ while the control produced small plants that weighed only 2.8 g plant⁻¹.

Nitrogen uptake by maize seedlings increased with increasing rates for all manure types (Table 6). Plant tissue N ranged from 1.14 to 2.03 g kg⁻¹ in non-amended manure treatment while in the control it was

Table 5. Effect of manure type × rate of application on biomass (g/plant) of maize seedlings at 56 days after planting

Manure type	Rate of application		
	5 t ha ⁻¹	7 t ha ⁻¹	10 t ha ⁻¹
CP + C	4.25	6.16	9.63
CP - C	5.27	7.76	13.70
MA + C	3.01	3.33	3.70
MA - C	3.17	3.44	3.99
MS + C	3.58	3.87	5.30
MS - C	3.79	4.13	6.53
SD + C	2.01	2.18	2.66
SD - C	2.29	2.35	2.81
N-REC	21.55		Lsd _(0.05,48df)
	= 0.66		
FP	13.03		S.E = 0.404
Control	2.78		

Where, CP = Coffee pulp + manure, MA = Non-amended manure, MS = Maize stover + manure SD = Sawdust + manure, N-REC = FURP (1994) recommendation (100 kg N ha⁻¹), FP = Farmers practice (7 t ha⁻¹ manure + 18 kg N ha⁻¹) and the Control = No soil amendment added. +C = with a polyethylene cover and -C without a polyethylene cover.

Table 6. The effect of manure type and rate of application on plant tissue N (g/kg) at 56 days after planting

Manure type	Rate of application		
	5 t ha ⁻¹	7 t ha ⁻¹	10 t ha ⁻¹
CP + C	2.34	3.82	6.74
CP - C	3.11	5.43	10.82
MA + C	1.14	1.47	1.81
MA - C	1.30	1.62	2.03
MS + C	1.90	2.13	3.29
MS - C	2.20	2.44	4.18
SD + C	0.56	0.72	1.09
SD - C	0.73	0.87	1.24
N-REC	24.57		Lsd _(0.05,48df)
	(interaction) = 0.35		
FP	9.77		S.E = 0.29
Control	1.28		

1.28 g kg⁻¹. Manure treatments that were amended with coffee pulp and uncovered had significantly higher tissue N ($p \leq 0.05$) than other types of manures and the control (Table 6). The lowest plant tissue N was observed at day 56 in treatments where sawdust was added.

Discussion

Effect of type of amendments and provision of polyethylene cover on nitrogen lost from cattle manure

The amount of N lost from manures that were covered was lower than that of uncovered manures. The covered manures also had higher moisture content during storage than the uncovered ones. Kirchmann and Lundvall (1998) in their study reported low N losses under anaerobic conditions. The energy and nutrient balance of organic materials is implied from the C: N ratio and the ideal C: N ratio lies between 15 and 25:1. Al-Kanani *et al.* (1992) reported the presence of insufficient organic carbon for the micro-organisms to make use of the entire N when the C: N ratio was below 15:1 and this would most likely result in NH₃ volatilisation. Conversely, when the C: N ratios are greater than 25:1, a deficiency of N is likely to occur, thereby restricting population growth of the micro-organisms responsible for decomposition of the manure. Though materials with high organic carbon and low N would be expected to cause net N immobilization when mixed with animal manures (Subair *et al.*, 1999), manure amended with sawdust with a C: N ratio of 34 lost more N than manure amended with coffee pulp and maize stover that had relatively lower C: N ratios of 16 and 19 respectively. Sawdust also had very high lignin: N ratio of 231 compared to the other agro-organic materials. Subair *et al.* (1999), found that slow decomposing materials that were high in lignin exhibited a lower rate of N immobilization, with immobilized N remaining in organic form for a long time. In contrast, low lignin materials exhibit high rates of decomposition, causing rapid N immobilization and subsequent re-mineralization without producing a pool of stable organic N (Subair *et al.*, 1999). Thus, Subair *et al.* (1999) concluded that materials with moderate lignin contents were more effective in reducing volatile N loss from amended manure. In this study, coffee pulp and maize stover with lower lignin: N ratios were more effective in reducing N losses through ammonia volatilization. Maize stover constitutes the main fodder for stall-fed cattle in the

study area and the leftovers are usually incorporated into the manure heaps. Dry stover is placed in the cowsheds as bedding material, which ends up in the manure heaps. In the coffee growing zones, coffee pulps are common pollutants around the factories and are usually available for free and as such the promising results show that there is a need to encourage farmers to incorporate these relatively cheap agro-organic wastes into manures to improve their quality.

Response of maize to the organic amended manures

The beneficial effects of manure in maintaining soil fertility and in particular its role as a source of plant nutrients, are dependent on the efficiency of the biodegradation process (Kihanda, 1996), which in turn determines the rate of release of nutrients and the equilibrium between retention and loss from the soil (Palm and Sanchez, 1991). The N from manure may be retained in the soil organic forms or released in inorganic form to the soil solution where it either accumulates, hence taken up by plants or lost through leaching or gaseous emissions (Murwira *et al.*, 1993). The rate of N mineralization from manure and indeed organic residues is regulated by temperature, moisture, soil type, soil pH and the quality of the organic material that is being decomposed.

Materials with a high C: N ratio and high lignin: N ratio and which immobilizes N such as sawdust are considered to be of low quality. Quality in this context referring to intrinsic factors that affect the rate of decomposition of the organic material such as C: N ratio, lignin content, nutrient content and particle size (Palm and Sanchez, 1991). High quality materials such as coffee pulp with lower C: N ratio and lower lignin: N ratio decompose rapidly and mineralize N easily upon incorporation in to the soil, hence their N release can be synchronized with crop demand (Myers *et al.*, 1994). However, the low quality organic materials would require more time to decompose (Amolo and Karanja, 1998). In this study, treatments where manure amended with sawdust was added, net immobilization occurred at all rates of manure application while with the unamended manure N immobilization occurred only at the highest rate of 10 t ha^{-1} . Kirchmann (1998), Lekasi *et al.* (2000) observed net N mineralization in aerobically produced manure when the C: N ratio was less than 15, while a net immobilisation occurred when the C: N ratio was greater than 25. Biomass yield and N-uptake were directly related to the N contribution. Since

in this experiment traces of ammonium were measured in all different manure types, ammonium may have been nitrified followed by denitrification. Ammonia volatilization from the soil surface was unlikely because of moderately acidic soil conditions with pH values of 5.2.

The higher biomass and plant tissue N obtained from N-REC, FP, CP+C and, CP-C, treatments resulted from higher N supply from the organic resources. Lower plant tissue N in the other treatments where sawdust was added was due to the net immobilization of N as observed at day 56. The results of this study are in agreement with studies reported by other investigators (Herbert *et al.*, 1991; Nyamangara *et al.*, 1999; Wheatley *et al.*, 1991; Ndayegamiye and Cote, 1989) who observed depressed rates of N mineralisation in soils receiving heavy application of wheat straw and sewage sludge.

Conclusion

The results of this study clearly demonstrate that efficient cycling of nutrients within the low external input farming systems used by smallholder farmers in the highlands of Central Kenya can be improved by minimising nutrient losses from the systems for long-term sustainability. The current practices are inefficient due to considerable nutrient losses during manure storage. As much as 40% of total N is lost under the current practice where manure is heaped outside the kraals and exposed to heat and rain. As the farms intensify and become smaller through subdivision, the need to enhance nutrient turnover becomes more important. The current systems can be improved by reducing nutrient losses from animal manures during storage and during field application. This can be achieved by improving the recovery of urinary N by using bedding materials such as sawdust, maize stover and other organic materials with high C: N ratio that would absorb urine and temporally immobilise N. The common practice in the agricultural areas is to burn these wastes (e.g. maize stover and sawdust) while coffee pulp is usually left to rot on factory grounds while small amounts are used as coffee mulch. Mixing these organic agro-wastes with stored manure is an economical and environmentally acceptable strategy of managing plant nutrients release patterns. Another strategy is to improve the handling and storage of manure through composting to stabilise N in

organic forms that are less susceptible to losses. Covering manure heaps during storage should also be promoted as substantial reduction in N losses is achieved when heaps are covered and sheltered from rain and heat.

Acknowledgement

We acknowledge with deep gratitude, the financial support from the European Union and the Rockefeller Foundation Forum for Agricultural Research Husbandry (FORUM). We are grateful to Director KARI and the Vice Chancellor University of Nairobi for allowing us to publish the study. We are indebted to the 3 farmers, Mr Wagacha, Mr Gathagu and Ms Wanjiku for their co-operation and participation in the trials and the staff of the Department of Soil Science for their assistance in analysis of the samples. We are also grateful to Dr Itabari for reading and correcting the draft paper. Lastly, much appreciation to the two anonymous reviewers for their useful comments.

References

- Al-Kanani T., Akochi E., Makckenzie A.F., Alli I. and Barrington S. 1992. Organic and inorganic amendments to reduce ammonia losses from liquid hog manure. *J. Qual.* 21: 709–715.
- Amolo R. and Karanja N.K. 1998. Nitrogen mineralization from cattle manure, filtermud, factory ash and N uptake by maize (*Zea mays*) in a glasshouse experiment. *East Africa Agric. and For J.* 62 (1).
- Anderson J.M. and Ingram J.S.I. 1993. Tropical Soil Biology and Fertility: A Handbook of Methods. CAB International, Wallingford, Oxon, England, 221pp.
- Bremner J.M. and Mulvaney R.L. 1982. Nitrogen Total, pp. 595–624. In: Page A.L. et al. (eds). *Methods of soil analysis. Part two. Agron. Monogr. 9. 2nd ed.* ASA and SSSA, Madison, WI.
- FURP 1994. Fertilizer Use Recommendation Project 1994. Kenya Agricultural Research Institute (KARI), Nairobi, Kenya.
- Gomez K.A. and Gomez A.A. 1984. Statistical Procedures for Agricultural Research. Second edition. Wiley-Interscience, New York, USA.
- Goran E. 2000. Seasonal availability of N from composted cattle manure and poultry manure in field and incubation studies. *Biol. Agric. and Hort.* 18: 161–174.
- Herbert M., Karam A. and Parent L.E. 1991. Mineralization of nitrogen and carbon in soils amended with composted manure. *Biol. Agric. and Hort.* 7: 349–361.
- Karanja N.K., Woome P.L., Kapkiyai J., Bunyasi S. and Murage E.W. 1997. Agriculture Resource Management in Smallholder Systems in Central Kenyan highlands. Department of Soil Science, University of Nairobi. Technical Report and Financial Statement, Rockefeller Foundation. Forum for Agricultural Research Husbandry (Grant RF94- 031 No. 35).
- Kihanda F.M. 1996. The role of farmyard manure in improving maize production in the Sub-Humid highlands of Central Kenya. Ph.D. Thesis, Department of Soil Science, Reading, United Kingdom, December 1996.
- Kihanda F.M. and Wood M. 1996. Effect of manure quality and soil type on the N mineralization in farmyard manures in the sub-humid highlands of Central Kenya. Paper Presented at the International Symposium on Carbon and Nutrient Dynamics in Natural and Agricultural Tropical Ecosystems. Harare, Zimbabwe, 29th April to 4th May, 1996.
- Kirchmann H. and Lundvall A. 1998. Treatment of solid animal manures; identification of low NH₃ emission practices. *Nutrient Cycling in Agroecosystems* 51: 65–71.
- Lekasi J., Tanner J., Kimani S.K. and Harris P. 2000. Effect of manure quality on maize productivity under field conditions in Central Kenyan highlands Nitisol. Collaborative and Participatory Research for Sustainable improved Livelihoods. 7th KARI Biennial scientific conference held at KARI headquarters Nairobi from 13–17 November, 200, pp. 123–132.
- Murage E.W., Karanja N., Smithson P.C. and Woome P.L. 2000. Diagnostic indicators of soil quality in productive and non-productive smallholders' fields of Central Kenya highlands. *Agric. Ecosy. and Env.* 79: 1–8.
- Murwira H.K., Swift M.J. and Frost P.G.H. 1993. Manure a key resource in sustainable agriculture. In: Powell J.M., Fernandez-Rivera S., Williams T.O. and Renard C. (eds), *Livestock and Sustainable Nutrient Cycling in Mixed Farming Systems of Sub-Saharan Africa*. Proceeding of an international conference, International Livestock Centre for Africa (ILCA), Addis Ababa, Ethiopia.
- Myers R.J.K., Palm C.A., Cuevas E, Gunatileke I.U.N. and Brossard M. 1994. The synchrony of nutrient mineralisation and plant nutrient demand. In: Woome P.L. and Swift M.J. (eds), *The management of tropical soil biology and fertility*. Wiley-Sayce, Chichester, UK.
- Ndayegamiye A. and Cote D. 1989. Effect of long term pig slurry and soil cattle manure application on soil chemical and biological properties. *Can. J. Soil Sci.* 69: 39–47.
- Nyamangara J., Piha M.I. and Kirchmann H. 1999. Interaction of aerobically decomposed cattle manure and nitrogen fertilizer applied to soil. *Nutrient Cycling in Agroecosystems* 54: 183–188.
- Okalebo J.R., Gathua K.W. and Woome P.L. 2000. Laboratory Methods of Soil Analysis: A Working Manual. Soil Science Society of East Africa Technical Publication No. 1. Marvel EPZ (Kenya) LTD, Nairobi, Kenya.
- Palm C.A. and Sanchez P. 1991. Nitrogen release from leaves of some tropical legumes as affected by their lignin and polyphenolic contents. *Soil Biol. Biochem.* 23(1): 83–88.
- Subair S., Fyles J.W. and O'Halloran I.P. 1999. Ammonia volatilization from liquid hog manure amended with paper products in the laboratory. *J. Environ. Qual.* 28: 202–207.
- Walinga J., Kithome M., Novozamsky I., Houba V.J.G. and van der Lee W. 1992. Spectrophotometric determination of organic carbon in soil. *Communications in Soil Science and Plant Analysis* 23(15&16): 1935–1944.

- Wamuongo J.W., Esilaba A.O., Miriti J.M., Mwangi J.N., Kimani S.K., Ademba J.S. and Nandokha T. 1999. The organic matter, nitrogen and phosphorus status of manure on smallholders' farms in central Kenya. Unpublished data.
- Wheatley R.E., Griffiths B.S. and Ritz K. 1991. Variations in the rates of nitrification and denitrification during the growth of potatoes (*Solanum tuberosum* L.) in soil with different carbon inputs and the effect of these inputs on soil nitrogen and plant yield. *Biol. Fertil. Soils* 11: 157–162.
- Woomer P.L., Bekunda M.A., Karanja N., Morehouse T. and Okalebo J.R. 1998. Agricultural resource management by smallholder farmers in East Africa. *Nature and Resources* 34(4): 22–33.

Soil characteristics and the performance of sorghum (*Sorghum bicolor* (L) Moench) on tin mine spoils of the Jos Plateau, Nigeria

A.A. Yusuf¹, A.F. Eben-Johnson, V.O. Chude and I.Y. Amapu

¹Department of Soil Science, Faculty of Agriculture/Institute for Agricultural Research, Ahmadu Bello University, P.M.B. 1044, Zaria, Nigeria; Corresponding author, e-mail: adamu_99@yahoo.co.uk

Abstract

Competitive land use in the Jos Plateau has forced farmers to start growing crops on mine spoils. An understanding of the soils' physico-chemical properties may provide an insight towards a proper management strategy. A laboratory study was carried out at the Institute for Agricultural Research; Samaru to determine some physico-chemical properties of five categories of tin mine spoils soils of the Jos Plateau. A pot experiment was also conducted to evaluate the performance of sorghum (*Sorghum bicolor* (L.) Moench) on these soils. The soil categories include reclaimed cropped spoil (RCS), reclaimed uncropped spoil (RUS), mining (intermount) depressions (MD), spoil mounds (SM) and surrounding flat land (SFL). Included as control are unmined Ropp soil (URS) and Samaru soil (USS). RCS soil had the highest amounts of organic carbon (13.7 g kg⁻¹) and total nitrogen (1.6 g kg⁻¹) while the URS which had the lowest organic carbon content (3.4 g kg⁻¹) had the highest available phosphorus content (18.31 g kg⁻¹). SM soils contained the largest amount of clay (347 g kg⁻¹) while USS soils contained the largest amount of silt (340 g kg⁻¹). The highest shoot and root dry weights were achieved on the reclaimed (cropped and uncropped) spoils, SFL and USS. These agronomic parameters were significantly lower ($P < 0.05$) on the MD and SM. Correlation studies between yield parameters and soil properties showed a highly positive significant ($P < 0.01$) correlation with silt, organic carbon, total N, Ca, Mg and K contents. The large silt content of USS is a reflection of the aeolian origin of the parent material. Copper was notably absent in USS soils but present in varying quantities in other soils. This was attributed to the presence of metal ore bodies in the rocks below the soil profile of mine spoils that could have contributed to the trace element contents of soils in its immediate vicinity. Generally, the differences observed in the magnitude of soil physical and chemical properties were as a result of management practices rather than the inherent soil type characteristics

Key words: Jos Plateau, Nigeria, reclamation, soil characteristics, sorghum, tin mine spoils.

Introduction

The Jos Plateau (Nigeria) is characterised by a number of bare rock surfaces, isolated volcanic cones, hills, intense mesas as well as deep depressions of valleys and rivers such that the availability of land for cultivation is relatively scarce. (Grove, 1952; Morgan, 1979; Dabi and Nyagba, 1999). This problem is further compounded within the tin-mining regions especially in Ropp District, which was used as a study area. Here,

the land has been further degraded by the Open cast method of mining employed and the resultant mine spoils (dumps, tailings, excavations, ponds and lakes).

Alexander (1986) reported that about 4% (325km²) of the total land in the Jos plateau (8600km²) has been degraded following mining activities and that these degraded areas are concentrated in the Bukuru-Barikin Ladi-Ropp axis of the Jos Plateau. Many studies have revealed that mining activities often have harmful effect on the environment. Scater et al (1980) observed that

mineral extraction by surface mining (Open cast) which is most prevalent in the Jos Plateau, drastically alters the physical, biological and chemical nature of the soil. New environmental conditions are created due to the removal of vegetative cover and disruption of soil physical and chemical properties. According to Davies and Jones (1988), metal ore bodies in the rocks below the soil profile contribute to its parent materials and thereby raise the soil trace element content in their immediate vicinity. They further asserted that losses of elements to the environment are possible at all stages of processing between separating ores from their host rock to the final product. Burkitt (1972) had earlier observed that mines and smelters are usually surrounded by an area of soil with high concentration of trace metals, which decrease exponentially from the stock. Also Jones and Jarvies (1981) noted that gravitational transport together with air and water erosion leads to the contamination of agricultural lands down slope of old mine waste heaps.

The state of the derelict mine lands of the Jos Plateau led the Nigerian Government to promulgate the mine lands act in 1946. This paved the way for the reclamation of mine spoils in the Jos Plateau by the Nigerian mines land reclamation unit (MLRU) and the Forestry Department of the Federal Ministry of Agriculture and Natural Resources, mining companies and the Joint Consultancy Committee (JCC) on mine lands reclamation were also involved in the reclamation (Dabi, unpublished, 1990). The reclamation method employed was the "level and fill" method whereby spoil mounds were bulldozed and ditches as well as flooded paddocks were filled. This method otherwise known as topsoil replacement could be a beneficial source of organic N and microbial inoculum (Woodmansee et al., 1978). Eucalyptus (*Eucalyptus camaldulensis*) tree seedlings were planted in order to stabilize the soils and produce a good tilt. Tolerance of extreme conditions provides the opportunity to use Eucalyptus trees to reclaim damaged agricultural landscapes and mine spoils of high soil solution ion concentration (Farrell et al., 1996). However, out of the about 325km² of mined land in the Jos Plateau only about 12.67km² (3.9%) has been reclaimed (Dabi, unpublished, 1990).

Adepetu (1985) reported that competitive land use in the Jos Plateau is putting pressure on the available land such that the local farmers are forced to grow crops on these mine spoils (both reclaimed and unreclaimed). Little or no information is available on the physical and chemical properties of the mine spoil soils of the Jos Plateau and no study has been conducted to evaluate

the influence of topsoil replacement on these properties. It would also be interesting to study the soil-crop relationship on these soils so that the challenges faced by the local farmer could be understood in its entirety. An understanding of the soils physical and chemical properties will provide an insight towards proper management. Therefore the objectives of this study were 1) to determine the physico-chemical properties of the various mine spoil soils (reclaimed and unreclaimed) in the Jos Plateau and comparing them with those of unmined (natural) soils from the Ropp district (Jos Plateau) and Samaru, Zaria, and, 2) to evaluate the performance of sorghum (*Sorghum bicolor* (L) Moench) on these soils in a pot experiment.

Materials and methods

Study area and soil sampling

Soil samples were collected from five different categories of mine spoils in Ropp district (9°30'N, 8°52'E) of the Jos Plateau. The climate is made up of two well-defined seasons: the dry and wet seasons. The dry season which commences from October lasts till April and it is characterized by dusty and cold harmattan winds. The wet season starts from around middle of April to middle of October with an average annual rainfall of 1500mm. Daily temperature during the wet season ranges between 23.5 and 28.9°C and the highest temperature during the dry season occur in March and April with a mean of 30.9°C.

The Ropp relief consists of undulating terrain within an average elevation of 1220–1300m. Frequent incidences of inselbergs, interspersed with half domes occur. These include the Ropp, Balfour and dome hills stretching in an East–West direction and covering an area of 61km² with Ropp peak dominating at 1639m (Hill, 1978).

The categories of mine spoils sampled were reclaimed uncropped soils (mined-lands that has been leveled and filled but are not being cropped by farmers) (RUS), reclaimed cropped spoil (leveled and filled mined lands being utilized for cropping by the local farmers) (RCS), spoil mounds (deposits or stack of dug up soil from the mined sites) (SM), mining depressions (actual dug up sites sometimes called inter mound depressions) (MD), surrounding flat lands of mounds (flat lands adjacent to the spoil mounds which are subject to effluents from the eroded mounds) (SFL). Unmined (natural) soils from Ropp (URS) and Samaru

(11°11'N, 07°37'E) (USS) were also sampled for comparison purposes. Soil was sampled from each category at 0–15 cm depth. Ten cores per 100m by 100m were taken (both diagonals across) and a minimum of 20 ha was covered in each category. Afterwards, equal amounts of soil sampled from each of the 100m² in a soil category were mixed to form one composite sample.

Laboratory studies

The composite soil sample was air-dried and screened to pass through a 2mm sieve. Sub samples were taken to the laboratory for the determination of some physico-chemical properties. All the six categories of soil collected from the Jos Plateau were classified as Oxic Ustropepts while the Samaru soil was classified as an Alfisol using the USDA soil classification system (Soil Survey Staff, 1975). The samples were analyzed for pH (H₂O) and pH (0.01M CaCl₂). Organic carbon was determined by wet oxidation method of Walkley and Black (1934). Total N and P in the soil were determined after oxidation of organic matter. Wet oxidation was based on Kjeldahl oxidation. Free ammonia was liberated from the digest by steam distillation in the presence of excess alkali. The distillate was collected in a receiver containing excess boric acid with an indicator (pH 4.5), and determined by titration. Total P in the digest was determined colorimetrically after colour development by ascorbic acid. Available phosphorus was determined by Bray no. 1 method (0.025 N HCl + 0.03 N NH₄F) as described by Bray and Kurz (1945). Exchangeable bases were extracted from the soil by leaching with 1M NH₄OAc at pH 7 for more than two hours. 20ml of the leachate was pipetted into 100ml volumetric flask and 20ml lanthanum chloride solution was added. K⁺ content was determined by flame emission spectroscopy and Ca²⁺ and Mg²⁺ by atomic absorption spectroscopy. Exchangeable acidity was determined by stirring the soil with 25ml 1M KCl and left for 30 minutes. The suspension was filtered and leached with five successive 25ml aliquots of 1M KCl. The filtrate was titrated with 0.1M NaOH (Anderson and Ingram, 1993). The effective cation exchange capacity (ECEC) was calculated by summing the exchangeable bases and exchangeable acidity. Particle size distribution was estimated by the hydrometer method of Bouyoucos (1951) while the micronutrients were determined following extraction with 0.1N HCl.

Greenhouse studies

A pot experiment was set up in the screenhouse of the Institute for Agricultural Research, Samaru (IAR), Latitude 11°11'N and Longitude 7°38'E, Ahmadu Bello University, Zaria, Nigeria, within the northern Guinea savanna.

From each category of the mine spoils and the natural Ropp and Samaru soils, five kilogrammes (5 kg) were weighed into 5L capacity plastic buckets each lined with polyethylene bags. Six seeds of sorghum (variety KSV 4) were planted and thinned to two seedlings per pot, two weeks after planting (WAP) and further thinned to one 3WAP. The experiment was laid down in a completely randomized design with three repetitions. At planting, 9.9 mg P and 18.7 mg K kg⁻¹ soil were applied while 11.5 mg N kg⁻¹ soil was applied after thinning while another 11.5 mg N kg⁻¹ soil was applied 6 WAP. Soil moisture content in the pots was maintained at field capacity by frequent watering to constant weight.

Plant height, stem diameter, number of leaves and leaf area were measured at intervals of two weeks in all the pots but only results obtained at 12 WAP are presented in this paper. At harvest (12 WAP), the above-ground part of the plants was cut at the base. The shoot and roots were washed with mild concentration (2%) of detergent, rinsed with deionized water, put in an envelope and oven-dried at 65°C for 48 hours. After drying to constant weight, the shoot and the roots were weighed.

Statistical analysis

The SAS (Statistical Analysis System Institute Inc., 1989) was used to perform analysis of variance (ANOVA) and where significant, specific pair-wise comparison of treatment levels (soil types) was done using the Least Significant Difference (LSD) test at P = 0.05.

Results and discussions

Physical properties

Particle size distribution

The results of the physical properties of the soils determined in this study are presented in Table 1. The unmined Ropp soil (URS) had the highest sand content

Table 1. Physical properties of the soils (0–15 cm) in Jos Plateau and Samaru

	Soil categories							
	SFL	SM	MD	RCS	RUS	URS	USS	Mean
Physical properties								
Sand content (g kg^{-1})	507	493	660	540	450	740	527	560
Silt content (g kg^{-1})	207	160	124	267	307	113	340	217
Clay content (g kg^{-1})	287	347	216	193	243	147	133	224

(740 g kg^{-1}) while the reclaimed uncropped soil (RUS) had the lowest mean value of 450 g kg^{-1} . Samaru soils (USS) contained the highest content of silt (340 g kg^{-1}) while the spoil mounds (SM), mining depressions (MD) and the URS had the lowest silt content ranging between 113 and 160 g kg^{-1} . On the other hand, soils of the SM contained the highest amount of clay (347 g kg^{-1}) while the USS and URS had the lowest clay content, which ranges between 133 and 147 g kg^{-1} . The large silt content of USS is a reflection of the aeolian origin of the parent material. Samaru soils are predominantly developed in a Quarternary loess mantle, which covered the Basement Complex (granites, gneisses, migmatites and schists). Soils on the Jos Plateau are formed over basement complex rocks. They have been affected by volcanic activities and are associated with the older and newer basalt. The soils are divided into series and the soils under the Vodni series are series are deep, imperfectly drained loam to sandy clay loam concretionary soils formed in mixed colluvial materials derived from weathered basalt and iron rubble (Hill and Rackman, 1973).

Chemical properties

Soil pH

All categories of soils from the Jos Plateau are moderately to very strongly acid while Samaru soil is near neutral (Figure. 1). The acidity of a soil is one of the most important properties to characterize its quality and fertility. The low pH of the Jos Plateau soils could be attributed to the fact that precipitation exceeds evapotranspiration so that basic cations are leached together with accompanying anions (bicarbonate, nitrate, sulphate, chloride). The cations; calcium (Ca), magnesium (Mg), sodium (Na) and potassium (K) are replaced by hydrogen (H) and aluminium (Al) ions which increase the acidity of the soil. The mean annual rainfall is 1400 mm and 1050 mm for Jos Plateau and Samaru respectively. At low pH, there is preponderance of

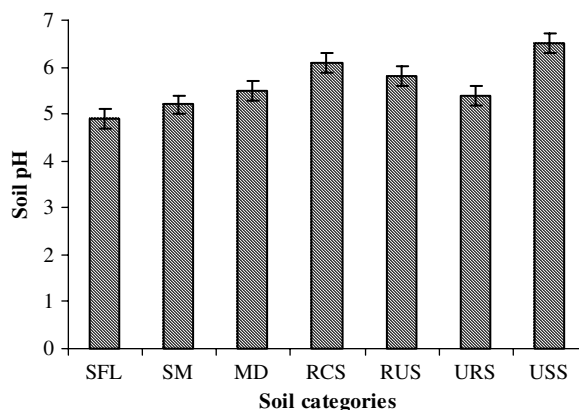

Figure 1. Soil pH (water) of the soils of Jos Plateau and samaru soils (0–15cm) See text for description of soil categories.

iron (Fe), manganese (Mn), and aluminium in the soil, which may be toxic to plants and may further reduce phosphorus (P) availability through fixation as insoluble phosphate complexes of these metals. (Marschner, 1995) Biological activities in the soil such as mineralization of organic matter, biological nitrogen fixation and the occurrence and activities of soil organisms are also influenced by soil pH. However, some crops such as potato, lupin, tobacco and rye have preference for weakly acid conditions (Janssen, 1999 Personal Communications). This may explain the fact that the Jos Plateau is the centre of potato production in Nigeria.

Total nitrogen

Reclaimed cropped soils (RCS) had the highest mean total nitrogen (N) content (1.6 g kg^{-1}) and was closely followed by SFL and RUS both with mean total N values of 1.2 g kg^{-1} (Figure. 2). The SM had the least total N value of 0.6 g kg^{-1} which was only slightly lower than that of both USS and URS (0.9 g kg^{-1}). These values were considerably higher than the mean

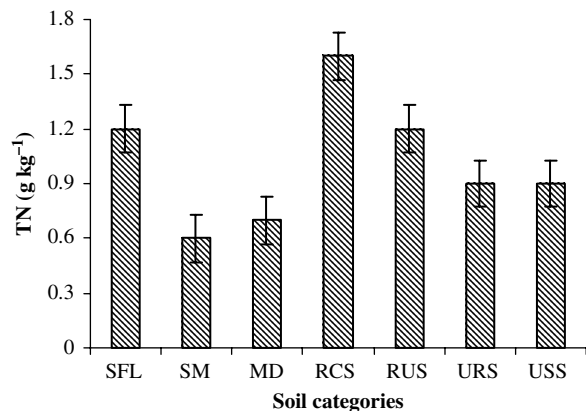

Figure 2. Total Nitrogen contents of Jos Plateau and Samaru soils (0–15 cm). See text for description of soil categories.

values observed by Balasubramanian et al (1984) for fallow and cultivated savanna soils of Nigeria; 0.49 g kg⁻¹ and 0.38 g kg⁻¹ respectively. The relatively poor N content of USS is attributed to continuous cropping without commensurate soil and nutrients conservation measures. Excessive rainfall in the Jos Plateau could partly explain the low total N content of most of the soils. Too much rainfall will have negative effect on the growth of natural vegetation, which may include leguminous species that could trap the atmospheric N into the soil. The RCS had a particularly high N content due

to soil amendments and plant residues that are regularly incorporated into the soil to enhance their productivity (Plate A). According to Alexander (1986), farmers cropping the mine spoils of the Jos Plateau often had to apply an exceedingly high amount of organic amendments to enhance the soil's productivity. One important cultural measure that can improve the present low levels of nitrogen in the Nigerian savanna soils is crop rotation involving legumes as one of the rotational crop.

Organic carbon

The organic carbon (OC) contents of the RCS and SFL soils were 13.7 g kg⁻¹ and 12.7 g kg⁻¹ respectively while the values of 3.4, 3.7 and 3.8 g kg⁻¹ were obtained for URS, SM and MD respectively (Figure. 3). All these values fall within the low class described for Nigerian soils (Enwezor et al., 1988). The organic carbon content of the reclaimed cropped spoils is 73% higher than those of the spoil mounds and the intermound depressions. Organic carbon and consequently organic matter influences both the physical and chemical properties of the soil and soils high in OC content are often regarded as "fertile soils". Low OC content of the IMD and SMD is accentuated by drastically shortened fallow and intensive, continuous grazing now common in the area (Plate B). This would have an adverse effect



Plate A. Spoil mounds with adjacent reclaimed cropped land under cultivation (note crop residues in the foreground).

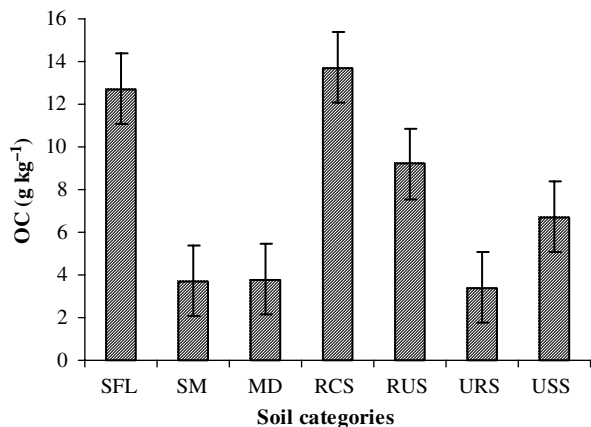

Figure 3. Organic carbon contents of Jos Plateau and Samaru soils (0–15 cm). See text for description of soil categories.

on plant growth. Increasing the organic matter content and improving soil productivity require the adoption of conservation tillage and proper management of plant residues and organic amendments.

Available phosphorous

The available P content of the soils ranged from 18.31 mg kg⁻¹ (highest) for URS to 0.81 mg kg⁻¹ (lowest) for the RUS (Figure. 4). These values are within the range

Soil characteristics and the performance of sorghum

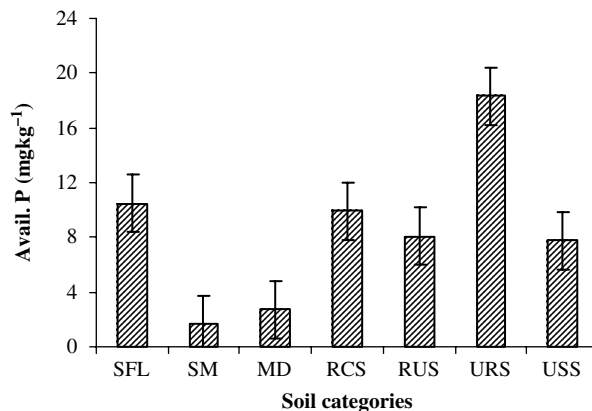

Figure 4. Available phosphorus contents of Jos Plateau and Samaru soils (0–15 cm). See text for description of soil categories.

of 0.70 to 20.80 mg kg⁻¹ reported by Mosugu (unpublished, 1989) for some Nigerian soils. The differences in P content of the various soils could be attributed to differences in cropping history of the soils as some of the soils might have had significant application of inorganic P fertilizer and farmyard manure (FYM) in the past. This statement is further given credence by the fact that all soils with history of extensive use of P fertilizers have favourable P status. It is therefore, not surprising that soils with previous history of cultivation such as SFL, RCS, URS and USS have higher contents of available P than SM, MD and RUS.

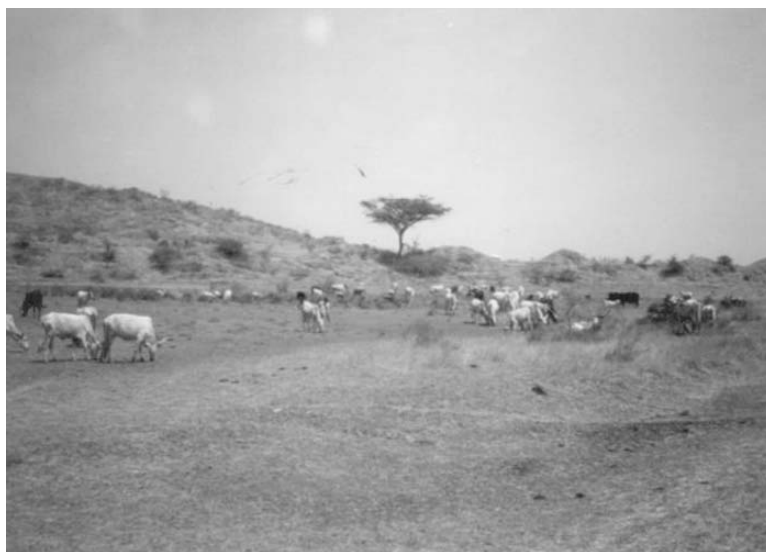

Plate B. Inter Mound Depression (Mound Depression) under grazing.

Exchangeable bases

Generally, the order of occurrence of cations on the exchange sites for all categories of soils in this study is $\text{Ca} > \text{Mg} > \text{K} > \text{Na}$. Calcium is often the dominant cation in soil solution. It is found in association with potassium, the cation with which it is most likely to exchange. The soils under study could be grouped into three categories based on the amounts of exchangeable bases present (Figure. 5). Category 1: SFL, RCS and URS have higher Ca^{2+} content ($3.20\text{--}6.17 \text{ cmolc kg}^{-1}$) than values reported by Ojanuga and Awujoola (1981). These soils also have the highest quantities of Mg^{2+} and K^+ . With the values obtained in Table 1, these nutrients would be rarely deficient in these soils. Category 2 namely: MD and RUS have medium contents of exchangeable bases while category 3; the SM and USS have low contents of exchangeable bases. Although Ca and Mg are the dominant cations on the exchange sites of the soils summed together but that not withstanding SFL, SM and MD have higher exchangeable K than exchangeable Mg. This corroborates the finding of Enwezor et al. (1988) that soils on the older basalts of Jos Plateau are low in exchangeable cations except K. Some of the soils may also respond to Ca and Mg fertilization for improved crop performance especially under high intensity cultivation. Rapid decline of organic matter content followed by extensive leaching of basic cations and development of subsoil acidity are common features under continuous cultivation without restoration of soil fertility. The blossom end rot disease of tomato and the black celery in celery are attributed to calcium deficiency (van Beusichem, Personal Communication).

Effective cation exchange capacity (ECEC)

The effective cation exchange capacity (ECEC) value is a measure of the cation holding power at field condition (Mott, 1988). The ECEC was estimated by the summation of exchangeable bases and exchangeable acidity. The values obtained ranged from $9.8 \text{ cmolc kg}^{-1}$ for SFL to $1.60 \text{ cmolc kg}^{-1}$ for USS (Figure. 6). The high ECEC value of SFL may also be attributed to its relatively high OC content since ECEC is concerned with the capacity of the soil to exchange cations not simply its capacity for exchangeable cations. It is suggested that the main source of cation exchange capacity (CEC) in the soil is the organic matter (Daudu, unpublished, 1993) and calcium, magnesium, potassium and sodium are the principal saturating cations on the exchange sites.

0.1NHCL extractable micronutrients

Very little information is available on the micronutrient status of Nigerian savannah soils perhaps due to the understanding that crops rarely show deficiency symptoms to these elements. However, recent research findings have shown crop response to some micronutrients and boron (B), Zinc (Zn) and Molybdenum (Mo) have been found to limit the growth of cotton, maize and legume respectively (Chude, 1998). The Fe content of the soils under investigation varies widely between 5.57 mg kg^{-1} to 27.67 mg kg^{-1} while manganese (Mn) content ranged between 6.67 and 42.67 mg kg^{-1} (Figure. 7). Both Fe and Mn deficiency do not normally arise from an absolute lack of these elements but because soil conditions restrict the supply to the roots. The presence of

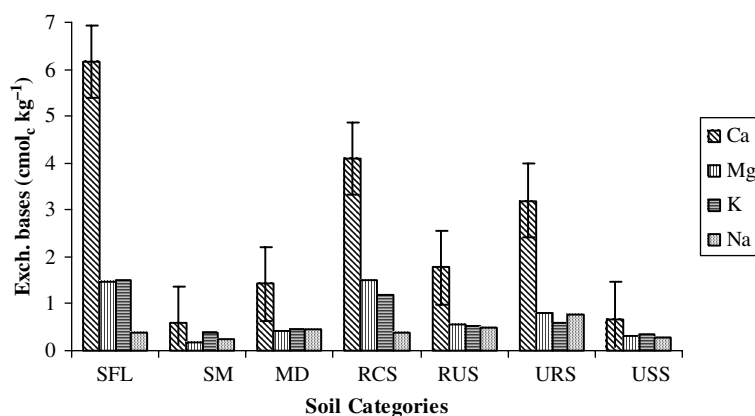

Figure 5. Exchangeable bases contents of Jos Plateau and Samaru soils (0–15 cm). See text for description of soil categories.

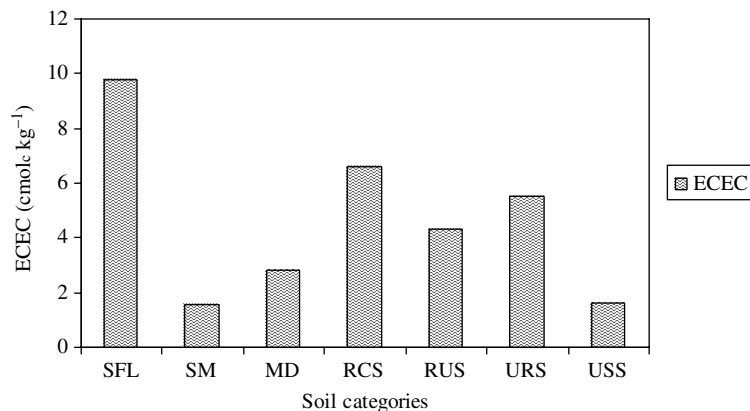

Figure 6. Effective cation exchange capacity of Jos Plateau and Samaru soils (0–15 cm). See text for description of soil categories.

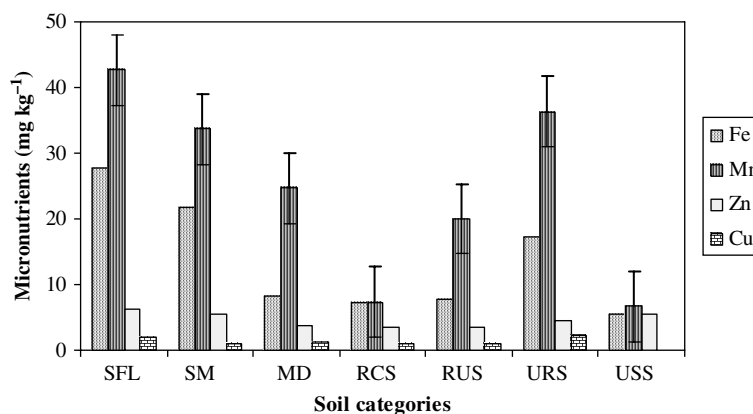

Figure 7. Micronutrient contents of Jos Plateau and Samaru soils (0–15 cm). See text for description of soil categories.

metal ore bodies in the rocks below the soil profile of mine spoils could also contribute to the trace element contents of the soils in its immediate vicinity. Soil pH strongly influences the availability of Fe, Mn and Zn in soils. It is therefore not surprising to observe that the magnitude of these elements in the soils decreases with increase in soil pH, so that SFL, MD and URS have higher contents. At soil pH greater than 8.0, deficiency symptoms could occur. On the other hand, the copper (Cu) content of the soil varied between 2.13 and 1.00 mg kg⁻¹ with the highest content in URS followed by SFL. Copper was not detected in USS perhaps due to its very low concentration in the soil or rather the inadequate sensitivity of the AAS used in the analysis. The RCS and RUS have the least content of Cu. The soils used for the reclamation could have developed over inherently low copper paved materials such as granites or sandstones.

Agronomic parameters

Growth parameters

The effects of the soil types on sorghum growth indices are presented in Table. 2. At harvest i.e. 12 WAP, sorghum plants on SM and MD had withered completely so that there was no single living plant in all the pots. RCS, RUS and SFL produced significantly high stem girth, leaf area and number of leaves. These were closely followed by USS. There was a significant ($P < 0.05$) difference in plant height between the reclaimed spoils and SFL. Sorghum planted on MD and SM had the least values of these growth parameters. Shoot and root dry weights recorded from each soil category followed similar pattern to the one observed in other growth parameters. The pattern of response is thus: RCS, RUS > SFL > USS > URS > MD > SM.

Table 2. Effect of tin mine spoils and natural Samaru and Ropp soils on sorghum growth indices

Soil type	Plant height (cm)	Stem girth (cm)	Leaf area (cm ²)	No. of leaves	Shoot dry weight (g)	Root dry weight (g)
Surrounding Flat Land	86.03b	2.67a	577.37a	9.00a	88.82a	29.19b
Spoil Mounds	0.0f	0.00d	0.00e	0.00d	3.46e	1.84f
Mound Depression	20.30e	0.77c	73.20d	3.00c	18.51d	8.65e
Reclaimed Cropped Soil	117.73a	3.10a	626.47a	10.00a	90.63a	36.24a
Reclaimed Uncropped Soil	116.87a	3.10a	600.03a	10.33a	91.49a	31.31ab
Unmined Ropp Soil	45.43d	1.61b	211.50c	6.67b	41.34c	16.24d
Unmined Samaru Soil	66.47c	2.67a	383.33b	9.33a	82.19b	23.92c

Means followed by same letter within a column are not significantly ($P > 0.05$) different.

Correlation between soil properties and agronomic parameters

Pearson correlation coefficients were calculated to assess the level of association between the various soil properties and agronomic parameters (Table. 3). Of the different particle sizes, silt was found to be highly significant ($P < 0.01$) in its correlation with leaf area, plant height, stem diameter, shoot and root dry weights. Other soil properties that were highly significant and had positive correlation with shoot and root dry weights include organic carbon, total nitrogen, calcium, magnesium and manganese. Sand had a significantly ($P < 0.05$) negative correlation with shoot dry weight ($r = -0.46^*$). Thus explaining why soils with

high sand content produced lower shoot dry weights. Manganese and Zinc produced a positive correlation with yield components while iron and copper had a negative and weak relationship.

Conclusion

The soils under investigation differ widely in physical and chemical characteristics and their ability to support crop growth. The differences observed in the mine spoils soils are surely rather the result of management practices than of inherent soil type characteristics. Because of the influence of environmental constraints

Table 3. Correlation analysis of yield components with soil properties

Soil properties	Yield components	
	Shoot dry weight	Root dry weight
Soil pH (Water) 1: 2.5	0.15	0.13
Available phosphorus	0.25	0.20
Organic carbon	0.82**	0.86**
Total nitrogen	0.80**	0.90**
Exchangeable Ca	0.50*	0.55**
Exchangeable Mg	0.58**	0.68**
Exchangeable K	0.54**	0.49**
Exchangeable Na	-0.02	0.06
Exchangeable acidity	0.30	0.25
ECEC	0.54**	0.59**
Fe	-0.05	-0.14
Mn	0.71**	0.72**
Zn	0.39	0.22
Cu	-0.17	-0.09
Sand	-0.46*	-0.38
Silt	0.67**	0.65*
Clay	-0.27	-0.26

* Significant at 5% level of significance.

** Significant at 1% level of significance.

and human interference on vegetative growth, only limited production of organic residues occurs. The higher available P content of RCS compared to the SMD, IMD and RUS e.g. is related to the use of external inputs rather than to the content of the parent material. On the other hand, the high silt content of the USS reflects the aeolian origin of the parent material, formed by deposition of loess-like material by hamattan winds. The absence of vegetation on SM and MD and RUS could explain their low OC and total N contents. Soil pH was found to strongly influence the micronutrients content of the soil with soils low in pH having the highest amounts of Fe, Mn and Zn. Since management practices could improve the physical characteristics of the tin mine spoils of the Jos Plateau, we recommend that further research be carried out to determine best approach to stop their degradation and enhance their reclamation for agricultural purposes.

References

- Adepetu, J.A. 1985. Farmers and their farms on four fadamas in the Jos Plateau. Report No 2, Jos Plateau Environmental Resources Development Programme.
- Alexander M.J. 1986. Soil Characteristics and the factors influencing their development on Mine spoils of the Jos Plateau. Interim Report No 11, Jos Plateau Environmental Resources Development Programme.
- Anderson, J.M. and Ingram, J.S.I. (Eds) 1993. Tropical soil biology and fertility. A handbook of methods (2nd edition). CAB International. 221pp.
- Balasubramanian V., Sing L., Nnadi L.A. and Mokwunye A.U. 1984. Fertility status of some upland savanna soils of Nigeria under fallow and cultivation. *Samaru Journal of Agricultural Research* 2: 13–23.
- Bouyoucos C.H. 1951. A recalibration of the hydrometer for making mechanical analysis of soils. *Agronomy Journal* 43: 434–438.
- Bray R.H. and Kurtz L.T. 1945. Determination of total, organic and available forms of phosphorus in soils. *Soil Science* 91–96.
- Burkitt A. 1972. *Nature*, London V. 238, pp. 327.
- Chude V.O. 1998. Understanding Nigerian soils and their fertility management for sustainable agriculture. Inaugural lecture series 13. Ahmadu Bello University, Zaria. 33pp.
- Dabi D.D. and Nyagba J.L. 1999. An alternative approach to the reclamation of Mine lands on the Jos Plateau Nigeria. *Journal of Environmental Sciences* 3 (2): 245–352.
- Davies B.E. and Jones L.H.P. 1988. Micronutrients and Toxic elements In: Wild, A (Ed) Russell's soil condition and plant growth, 11th edition. Longman, New York. pp. 780–814.
- Enwezor W.O., Udo E.J., Usoroh N.J., Ayotade K.A., Adepetu J.A., Chude, V.O. and Udegbe C.C (Eds) 1988. Fertilizer use and management practices for crops in Nigeria. Series No 2, F.P.D.D. Federal Ministry of Agriculture Water Research and Rural Development Lagos. 161pp.
- Farrell R.C.C., Bell D.T., Akilan K. and Marshall J.K. 1996. Morphological and physiological comparisons of clonal lines of *Eucalyptus camaldulensis*. II. Responses to waterlogging/salinity, and alkalinity. *Australian Journal of Plant Physiology* 23 (4): 509–518.
- Grove A.T. 1952. Land Use and Soil Conservation on the Jos Plateau, Geological Survey of Nigeria, Bulletin 22.
- Hill I.D. (Ed) 1978. Land resources of central Nigeria. Agricultural Development Possibilities Vol. 2B. The Jos Plateau Land Resource Study 29, LRD/ODA Tolworth.
- Hill I.D. and Rackman L.J. 1973. The land resources of central Nigeria. Phase 1; Vol. 1: Land forms and soils. Miscellaneous Report 153, Surbition Survey, England. 115pp.
- Janssen B.H. 1999. Nutrients in soil plant relationships I (J100-230). Lecture Notes, Wageningen University, The Netherlands. 291pp.
- Jones L.H.P. and Jarvis S.C. 1981. The Chemistry of Soil Process. In: Greenland D.J. and Hayes M.H.B. (Eds). *Soil Chemistry*, Wiley. 593pp.
- Marschner H. 1995. *Mineral nutrition of higher plants*. Second edition. Academic press.
- Morgan W.T.C. (Ed) 1979. The Jos Plateau, A survey of Environment and Land Use. Occasional Publication (New series) 14. Department of Geography, University of Durham U.K.
- Mott C.J.B. 1988. Surface Chemistry of soil particles. In: Wild A (Ed) Russell's Soil Conditions and Plant Growth, 11th edition, Longman, New York. pp. 239 – 281
- Ojanuga A.G. and Awujoola A.I. 1981. Characteristics and Classification of the soils of the Jos Plateau, Nigeria. *Nigerian Journal of Soil Science* 2: 101–119.
- SAS (Statistical Analysis System Institute Inc.) (1989) SAS/STAT User's Guide. Version 4th edn. Vol. 1, Cary, NC.
- Scater W.M., Nelson G.A. and Nettleton W.D. 1980. Mine Soil Genesis and Morphology in a spatial chronosequence in Montana. *Soil Science Society of America Journal* 44 (4): 802–807.
- Soil Survey Staff 1975. *Soil Taxonomy: a basic system of Soil Classification for making and interpreting soil surveys*. Agric. Handbook 436, U.S. Govt. Printing Office. Washington, D.C. 75pp.
- Walkley A. and Black I.A. 1934. An examination of the Degtjaref method for determining soil organic matter and a proposed modification of the chromic acid titration method. *Soil Science* 37: 549–546.
- Woodmansee R.G., Reader J.D. and Berg W.A. 1978. Nitrogen in drastically disturbed lands. In: Youngberg C.T. (Ed.) *Forest and soil land use*. Department of Forestry and Wood Science, Colorado State University, Ft. Collins. pp. 376–392.

The development of a prototype land information system for the northern Guinea savanna of Nigeria as a basis for agro-technology transfer

Tabi F.O.¹, Ogunkunle A.O.², and Diels J.^{3*}

¹Faculty of Agronomy and Agricultural Sciences, University of Dschang, Rep. of Cameroon; ²Agronomy Department, University of Ibadan, Nigeria; ³International Institute of Tropical Agriculture (IITA), Ibadan, Nigeria, Division Soil and Water Management, Katholieke Universiteit Leuven, Celestijnenlaan 200E - Box 2411, B-3001 Leuven, Belgium; *Corresponding author: jan.diels@biw.kuleuven.be; Tel: +32 16 32 9744; Fax: +32 16 32 97 60

Abstract

Data and maps from soil surveys conducted in the past can assist to better target agricultural technologies and to make technical recommendations more site-specific. Although data on soil and land characteristics are available for the northern Guinea savanna (NGS) agro-ecological zone of Nigeria, they are not in a form that can be easily retrieved, combined with other information, and used for decision-making in crop production and in planning agro-technology transfer. Now that appropriate tools are available for creating databases and for more quantitative analyses and interpretation of data, the potential of a given technology can be assessed over a large geographical support. This study was designed to evaluate major soils in a 20,000 km² test area in the NGS of Nigeria in terms of yield returns with the use of mineral fertilizers, farmyard manure (FYM) and their combination. A second objective was to develop a land information system to support the transfer of combined use of mineral fertilizers and farmyard manure within the entire NGS.

The performance of the Quantitative Evaluation of the Fertility of Tropical Soils (QUEFTS) model to estimate potential nitrogen and phosphorus supply capacities of soils as well as maize grain yield estimates was tested, and next used to estimate yields for available soil profiles within the test area. Other empirical models were used for the quantification of the land qualities moisture supply capacity, susceptibility to crusting, and susceptibility to water erosion that related to maize production in the agro-ecological zone. An attribute database of soil properties, land characteristics, land qualities and predicted maize grain yield was established and linked to a spatial database (land system map). The 20,000-km² test area within the NGS agro-ecological zone was stratified into different land management units (LMUs) based on the QUEFTS-based estimates of maize grain yield when no fertilizer or manure is applied. Three land management units of significantly different ($P < 0.05$) yield potential were delineated in the larger test area, with the first management unit LMU1 (687 kg ha⁻¹) being the least productive and the third, LMU3 (1382 kg ha⁻¹) the most productive.

Major soils in the NGS benchmark area are responsive to combined use of FYM and mineral fertilizers. Response to this integrated nutrient management (INM) technology is expected in the larger target area, because of the similarity in native soil fertility status and other crop production constraints (provided by the land information system developed) of the larger NGS benchmark area with that of the two villages in which the INM technology was tested on-farm. Response is expected to be highest in LMU1 (if measures to check erosion and to reduce surface crust are taken into consideration) and least in LMU3

Key words: Integrated nutrient management; maize; land information system; agro-technology transfer

Introduction

Spatial extrapolation or up scaling of research results to wider areas has always been a challenge to the agricultural research-for-development community. Adaptive agricultural research is usually done in a small number of representative research villages or sites, but results ultimately need to drive agricultural technology transfer in a large target zone. The traditional approach consists of dividing the mandate area in agroecological zones, and next subdividing these into subzones or resource management domains which are sufficiently homogeneous in terms of the key biophysical and socio-economic factors. Adaptive on-farm research in carefully selected sites/villages representative for the subzones then leads technologies applicable to the entire subzone (Mutsaers et al., 1997). While this no doubt helps to deal with some major sources of variability, results will not be meaningful to farmers if variability at more detailed scales, such as variation in soils occurring at the soilscape level, is neglected (Deckers, 2002).

Land information systems offer the possibility to take into account the variability in land characteristics, and to link information available at the macroscale (scale at which resource management domains, soil associations and land systems are defined, and province/county/zonal level statistics exist) with information available at mesoscale (soil types and land use within land facets or sections along toposequences, results from experimentation on several fields within a village). Heineke et al. (1996) defined a land information system (LIS) as a database system containing a wide range of soil and related land information with procedures for its use that go beyond mere representation. In the contemporary world, the elements of a land information system include a computerized database containing available information on topography, soils, climate, vegetation and land use, with compatible databases of socio-economic factors, a GIS that links each item of information to its precise geographical location but which can display each type of information as a separate layer or overlay. The system should contain a set of crop yield models that can calculate the level of production obtainable from each and any combination of soils, climate in the region at a number of different input or management levels, environmental impact models that permit calculation of rates of erosion for a given land unit, use and production system (Oldeman and van Engelen, 1993). A land information system could be seen today as an online

repository of information that enables the most efficient use of land for agricultural and natural resources management. Many countries in Europe and other continents have since developed land information systems that are constantly being updated (Heineke et al., 1996) but many countries in sub-Saharan Africa are lagging behind in this aspect. Magoggo (1989) developed a soil information system for Tanzania (SISTAN), which is an important step in the development of a land information system. Similar efforts were made for southern Benin and Niger (Graef et al., 1998; Igué et al., 2004).

Although the use of land information systems cuts across several disciplines with different procedures outline for its use, a common point of convergence is that planners are aware of LIS as important tools for decision making (Burrough, 1986; de la Rosa et al., 1992; Beek et al., 1997). When the data collected during field surveys and agronomic experiments, thus stored in a LIS, are coupled with decision-aids or models, they could be used to support the transfer of a given agro-technology by better targeting areas where impact is expected to be high.

Sustaining soil fertility in the face of rapidly increasing land use intensification in West Africa remains a key challenge (Keatinge et al., 2001). Solely relying on organic sources of plant nutrients will not suffice to ensure the required production increases (Dudal, 2002), but the use of mineral fertilizers remains limited over Africa due to high costs and inefficient marketing systems (Honlonkou et al., 1999). Experimental evidence from the northern Guinea savanna (NGS) agro-ecological zone of Nigeria indicates that combining organic sources of plant nutrients with mineral fertilizers is a better practice to increase crop yield than sole application of mineral fertilizers (Iwuafor et al., 2002). However, targeting this technology in the entire NGS remains a challenge in view of the enormous diversity in social and environmental conditions that prevail. First, availability of organic resources is a key constraint, caused by competing uses of crop residues (Bationo et al., 1995) and the small quantities of animal manure available per unit of cultivated land (Williams et al., 1995). Availability of organic resources therefore varies across the NGS depending on factors such as land use intensity, labour cost, and livestock densities. Secondly, crop response to fertilizer and organic matter depends highly on the nutrient supply capacity of the soil and on other site-specific conditions. Deckers (2002) noted that targeting balanced nutrient management technologies in the complex farming environment has been an issue of long-standing debate.

Appropriate transfer strategies should be based on correct baseline data that provides information on the variability of physical resources, other limiting factors that have to be considered together with the technology as well as the scale(s) to recommend the technology. Since ecological systems are organized hierarchically with many feedback mechanisms across overlapping scales in space (Hoosbeek and Bryant, 1992; Schulze, 2000), scales have to be transcended in the development and transfer of agro-technologies. Many scientists, however, neglect this aspect and rarely consider the above-mentioned factors in planning the transfer of agro-technologies. Since the first step in planning agro-technology transfer is the assessment of the resource base of the target areas, this study was designed to evaluate major soils in a target area in northern Nigeria in terms of yield returns with the use of mineral fertilizers, farmyard manure (FYM) and their combination. The second objective was to develop a prototype land information system to support the transfer of combined use of mineral fertilizers and farmyard manure within the target area.

Materials and methods

Description of the study area

This study was conducted in the Northern Guinea Savanna (NGS) agro-ecological zone of Nigeria. The NGS covers an area of about 34 million ha in West and Central Africa. It is characterized by a sub-humid climate with a unimodal rainfall distribution pattern and a length of growing period of 151–180 days (Jagtap, 1995). Temperatures during the rainy period in the study area are 27–34°C (maximum) and 18–21°C (minimum). The mean annual rainfall is between 1200 mm and 1700 mm.

This study was carried out within the NGS benchmark area (Figure 1), which is a smaller area (6.5%) of the entire NGS. Manyong et al. (2001) conducted a resource management survey (based on access to markets, pressure on land, and adoption of technological options) in the benchmark area to identify development patterns that drive the dynamics in the use of natural resources. Four resource-use domains were delineated as follows: low resource-use domain (13.8% of survey villages), low-to-medium (49.2%), medium-to-high (23.1%), and high (13.8%). Two villages, Kayawa (7°13'E, 11°13'N) and Danayamaka (7°50'E, 11°19'N) within the NGS benchmark area typical of

the two major resource-use domains (medium-to-high and low-to-medium respectively) of the benchmark area (Manyong et al., 2001) were chosen for on-farm research. Within each village, a typical toposequence (2.5 km long in Danayamaka and 1.7 km long in Kayawa) were identified for detailed soil characterization (Delauré, 1998).

The terrain in the benchmark area consists of gently undulating plains. The soils developed on basement complex granites, gneisses and schists (McCurry, 1970) overlain by aeolian deposits (Bennett, 1980). The soils are varied and the pattern of distribution can be complex. Generally, shallow and/or gravelly soils (Petric Plinthosol) occur on the interfluvial crests, deep soils (Ferric Luvisol and Ferric Lixisol) on the valley slopes and hydromorphic soils (Gleysol and Fluvisol) on the valley bottoms (Delauré, 1998). Topsoil texture ranges from sandy loam to clay loam underlain by sandy loam to clayey textures. The soils often contain manganiferous concretions as well as quartz fragments. Kaolinite is the dominant mineral in the clay fraction of all the well-drained soils (Moberg and Esu, 1991). A common feature is the wide occurrence of secondary pedogenic ironstone in various forms, at various depths and with little predictability.

The representative villages, Danayamaka and Kayawa, and most of the wider NGS benchmark area, fall within a broader region – Central Northern Nigeria where soil data exists from a reconnaissance soil survey conducted in 1977 (Bennett et al., 1977). Some of the products of the survey include: a land system map with geo-referenced soil profiles, accompanying report on site characteristics, land use and related soil analytical data. This data could be used to scale up recommendations on the use of FYM and mineral fertilizers generated (on a detailed scale) at the research villages.

Selection and characterization of farmers' fields

Thirteen fields in Kayawa and 14 in Danayamaka were selected to implement researcher-managed on-farm trials. The selection was done by randomly selecting from a list of all fields of a randomly selected subset of farmers in the villages. The selected fields occurred on various positions in the landscape. Fields near the valley bottom (fadamas) were however excluded during the selection, since they are seasonally flooded and therefore not suitable for maize production.

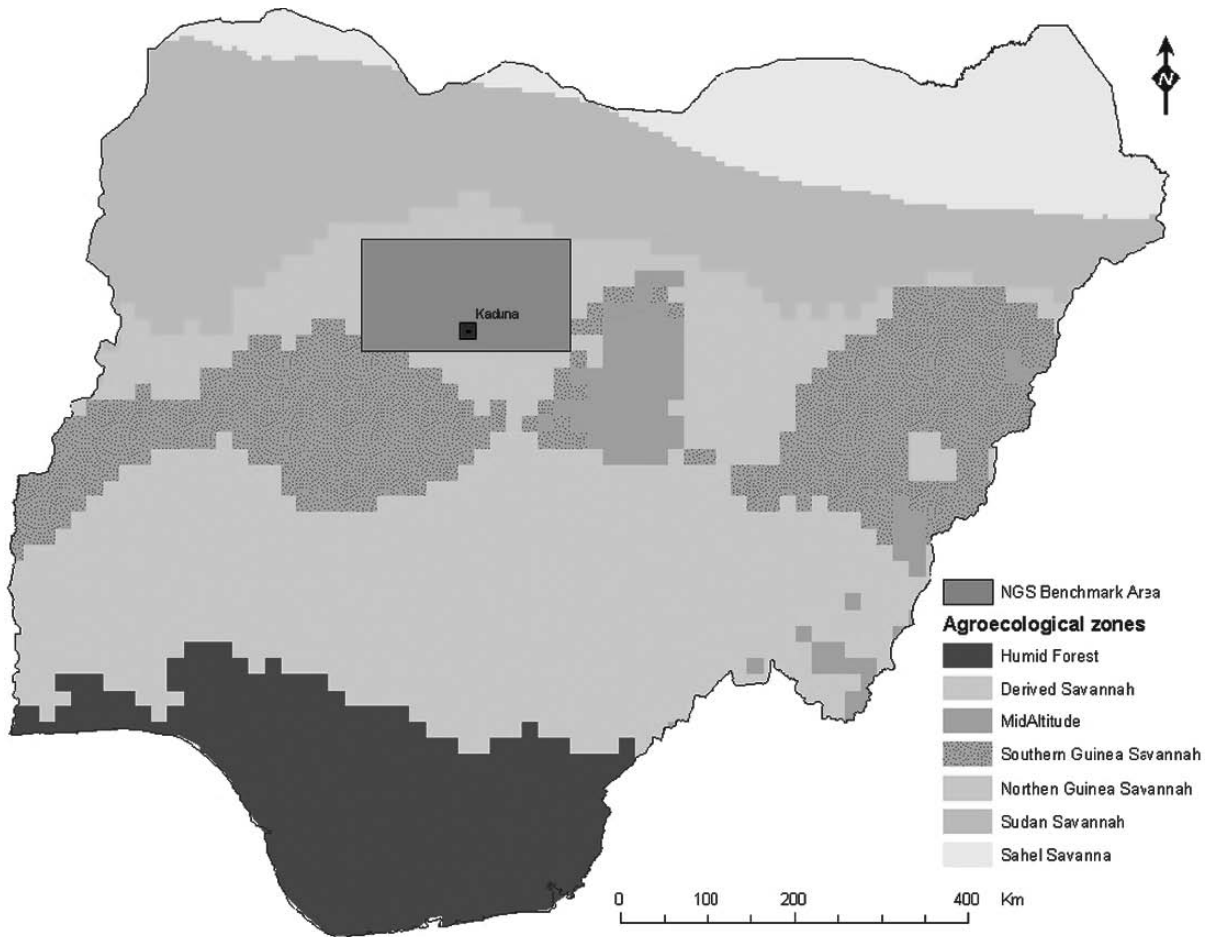

Figure 1. Map of Nigeria showing benchmark area.

Four points (located diagonally) in each field were augered to a depth of 120 cm where possible and soil morphological properties were described. Data were collected on the following: texture, structure (approximate), and presence of plinthite, Fe/Mn concretions, depth to gravel, gravel content, presence of mottles, and the slope of the field. These features were matched with those of georeferenced soil profiles located along transects in the two research villages, in order to group the soils of the 27 fields into already defined taxonomic classes. The soils of the 27 fields were distributed among Ferric Luvisol, Ferric Lixisol and Eutric Gleysol (FAO/UNESCO classification) or Alfisols, Inceptisols and Entisols (USDA Taxonomy). Most of the fields were located on the upper middle slope position of the landscape, some on the upper slope (interfluvial crest) and the lower middle slope positions and a few on the foot slope.

Six plots (8m × 8m each) were demarcated in each farmer's field. In each plot, soil from 0–10 and 10–30 cm was taken in the ridges on a position halfway between the furrow and the top of the ridges. Ridges are usually formed with soil from 0–10 cm depth. Samples (10 cores) collected per plot were later bulked on a field basis for each depth. All samples were air-dried and sieved through a 2 mm sieve. Routine soil analysis was run on these samples. Particle size analysis was carried out using Bouyoucos hydrometer method (Bouyoucos, 1962) and pH was measured both in water and in KCl (1:2.5 soil/water mixture) using the glass-electrode pH meter. Part of the soil was ball-milled for OC (Amato, 1983) and Kjeldahl-N analysis. Available P (Olsen P) was determined by the method of Olsen and Sommers (Okalebo et al., 1993), while exchangeable cations were determined by extracting with 1 N ammonium acetate at pH 7. Potassium and Na in the

extracts were measured using a flame photometer while Mg and Ca were determined using an atomic absorption spectro-photometer. The soils were also analysed for exchangeable acidity and effective cation exchange capacity (ECEC) (IITA 1982). Undisturbed core samples were collected at the soil surface for bulk density determination.

Field experiment

Field experiments were conducted on selected farmers' fields in the two villages to determine the response of a maize crop to combined use of farmyard manure (FYM) and mineral fertilizers. Total rainfall during the 4-month maize growing period amounted to 1200 mm, and was well distributed. Six treatment combinations involving mineral fertilizers and FYM (cowdung) were used in this study. The choice of the N and P rates used in this study was based on results from an on-station trial in Samaru, Zaria, where the response of maize to combined application of mineral fertilizers and FYM was evaluated (Vanlauwe et al., 2001). Table 1 shows the treatment combinations used in the trial. Phosphorus was applied as triple superphosphate (TSP) and K as KCl. The FYM was cow dung purchased from a nearby animal research station, and had a dry matter content of 89%, and nutrient contents on a dry matter basis were 14.9 g N kg⁻¹, 2.5 g P kg⁻¹, 26.6 g K kg⁻¹, 10.3 g Ca kg⁻¹, and 3.6 g Mg kg⁻¹. The manure was buried during ridging. Split application of nitrogen was employed: 1/3 at 2 weeks after planting (WAP) and 2/3 at 6 WAP. Spot fertilizer application was done at 5 cm from the crop and to a depth of 10 cm. Fertilizer was covered with soil in order to reduce volatilization losses. Potassium and phosphorus were applied in a single dose at 2 WAP. Maize was planted at a spacing

of 25 cm along ridges and 75 cm between ridges, at the rate of 2 or 3 seeds per hole. This was later thinned to 1 seedling per stand at 2 WAP, giving a total of 320 plants per plot (53,333 plants ha⁻¹). Two weedings were done before harvest. The first was between 4 and 5 WAP and the second at 7 and 8 WAP. Maize cobs were harvested when the silk had turned brown and the cobs dry. In the determination of crop yield, border rows were avoided and yield was determined based on a net plot of 4.5 m by 6 m (27 m²) having a plant population of 144 plants. Maize grain yields were corrected to 12% moisture content.

Plant analysis

At harvest, fifteen maize cobs and 5 stovers were randomly selected from each net plot and weighed separately, dried to constant weight to determine the dry matter content, and analysed for N and P content by hot acid digestion followed by colorimetric determination on a Technicon autoanalyser following a method adapted from Searle (1984) for N and the method of Murphy and Riley (1962) for P. The total nutrient uptake by maize for each treatment was determined as the product of nutrient concentration of the sample, its dry matter content, and the quantity of fresh matter harvested on the harvest net plot.

Quantifying relevant land qualities for maize production

The following land qualities were quantified for each field in the 2 research villages (Danayamaka and Kayawa): potential nitrogen (SN) and phosphorus (SP) supply capacities, moisture supply capacity (MSC), susceptibility to crusting (IC) and susceptibility to erosion (A). The N and P supply capacities were estimated according to the following empirical equations (Tabi, 2004):

$$SN = 6.41 \times OC \times \left(1 - \frac{35.27}{clay}\right) \quad (1)$$

$$SP = 0.45 \times (1 - 0.5 \times (pH - 6)^2) \times OC + 0.63 \times OlsenP \quad (2)$$

where OC is the organic carbon content (g kg⁻¹) of the top soil, 'clay' is the clay content (g kg⁻¹), pH the pH in water, and 'Olsen P' the Olsen P content in mg kg⁻¹.

Table 1. Treatments in on-farm trials in Kayawa and Danayamaka

Treatments	Applied nutrients (kg ha ⁻¹)			
	Nitrogen as urea	Nitrogen as FYM	Phosphorous (TSP)	Potassium (KCI)
T1	0	0	30	30
T2	0	60	30	30
T3	60	0	30	30
T4	120	0	30	30
T5	30	30	30	30
T6	120	0	0	30

FYM represents farmyard manure.

Plant available water (PAW), defined as the difference in soil moisture held at field capacity (FC) and that held at permanent wilting point (PWP), was used as an index of soil moisture supply capacity:

$$\text{PAW}(\text{cm}^3 \text{cm}^{-3}) = \text{FC} - \text{PWP} \quad (3)$$

where FC is the water content at field capacity (pF2.0), and PWP is water content at permanent wilting point (pF 4.2).

The index of crusting (IC) defined by FAO (1979) was used as an indicator for susceptibility to crusting:

$$\text{IC} = \frac{\text{Silt}(\%)}{\text{Clay}(\%)} \quad (4)$$

An IC < 1.5 signifies that a soil is not susceptible to crust formation and when greater than 2.5, it is highly susceptible (FAO, 1979).

The universal soil loss equation (USLE) of Wischmeier and Smith (1978) taking into consideration modifications in the estimation of erosion factors for the tropics (Nill, 1993) was used in calculating annual soil loss (an index of susceptibility to erosion):

$$A = 0.224 \times (R \times K \times L \times S \times C \times P) \quad (5)$$

where A denotes soil loss ($\text{kg m}^{-2} \text{yr}^{-1}$), R is the index of rainfall erosivity, K is the soil erodibility factor, L is the slope length factor, S is the slope gradient factor, C is the crop management factor and P is the erosion control practice factor. Slope lengths were measured with a tape while slope gradients were measured with a clinometer. Annual soil loss less than or equal to $2000 \text{ kg ha}^{-1} \text{yr}^{-1}$ is referred to as tolerable soil loss, but when greater than $2000 \text{ kg ha}^{-1} \text{yr}^{-1}$, the soil is said to be susceptible to erosion (Roose and Sarrailh, 1989).

Maize grain yield predictions

The Quantitative Evaluation of the Fertility of Tropical Soils (QUEFTS) model (Janssen et al., 1990) was modified for the NGS of Nigeria and used to predict maize grain yield under different levels of soil fertility management. Details of the modified QUEFTS are reported in Tabi (2004). The modifications are shown below:

1. Potential N and P supply capacities were estimated using equations 1 and 2.

Land information system for agro-technology transfer

2. Actual uptake of N (UN) and P (UP) by maize (from unfertilised plots) were estimated from the following equations:

$$\text{UN} = \text{SN} - \frac{0.25 \times (\text{SN} - 5 - (\text{SP} - 0.4) \times (97/70))^2}{(\text{SP} - 0.4) \times (600/21 - 97/70)} \quad (6)$$

$$\text{UP} = \text{SP} - \frac{0.25 \times (\text{SP} - 0.4 - (\text{SN} - 5) \times (21/600))^2}{(\text{SN} - 5) \times (70/97 - 21/600)} \quad (7)$$

3. Contributions of FYM and mineral fertilizers to actual nutrient uptake were included.

Application of manure and fertilizers would increase the supply of nutrients to the crop and consequently the amount taken up by the crop. Fertilizer equivalence of FYM was estimated in order to have a common criterion to assess the contributions of manure and mineral fertilizers to actual uptake of nutrients by maize. The fertilizer equivalence (FE) of manure was estimated using the concept of fertilizer replacement index as described for cover crops by Tian et al. (2000):

$$\begin{aligned} & \text{NFE}(\text{kg N ha}^{-1}) \\ &= \frac{(\text{Maize total N uptake with FYM} \\ & \quad - \text{maize total N uptake in 0N control})}{\text{Maize total N uptake increase by N fertilizer}} \quad (8) \end{aligned}$$

where NFE is the N fertilizer equivalence of FYM, and maize total N uptake increase by N fertilizer (in kg ha^{-1}) is the average of:

$$\frac{(\text{Maize total N uptake in 60 N (urea)} \\ - \text{maize total N uptake in 0 N control})}{60}$$

and

$$\frac{(\text{Maize total N uptake in 120 N (urea)} \\ - \text{maize total N uptake in 0 N control})}{120}$$

From the on-farm experiment, the P fertilizer equivalence of FYM could not be determined since no treatments were available where P was the only limiting nutrient. N and P contributed by FYM and mineral fertilizers (that adds to actual uptake) was calculated as:

$$\begin{aligned} & (\text{Fertilizer rate} + \text{fertilizer equivalence of FYM}) \\ & \times \text{fertilizer recovery fraction.} \end{aligned}$$

Fertilizer recovery fractions for applied N and P vary considerably, but average values of 0.5 for N and 0.1 for P are commonly cited (Smaling, 1993). We used that of Smaling (1993) since it is the most frequently used.

4. Yield prediction functions.

QUEFTS considers N, P, K in making yield estimates but in this study, only N and P were considered since according to the soil analysis K was in adequate supply. Reference will be made further only on the N and P equations as modified by Tabi (2004):

$$YNA = 21 \times (UN - 5) \tag{9}$$

$$YND = 70 \times (UN - 5) \tag{10}$$

$$YPA = 97 \times (UP - 0.4) \tag{11}$$

$$YPD = 600 \times (UP - 0.4) \tag{12}$$

Where YND and YPD represent maize grain yields in situations where N and P respectively are the main yield-limiting factors. In such a situation, the nutrient is maximally diluted in the plant and the yield is the highest possible given the amount of absorbed nutrient. YNA and YPA represent maize grain yields in situations where N and P respectively, are excessively

available. In this case, the yield is limited by one or more growth factors other than the nutrient concerned. Thus the nutrients are maximally accumulated in the plant or less efficiently utilized.

The equations above represent ideal situations specified by Janssen et al. (1990) where no growth factors other than N, P and K are limiting maize production. When other factors are limiting, maize grain yield specified at maximum N dilution for example, may not be attainable. It is therefore important to account for the limitations to crop production brought about by other factors of production.

Combining the yield ranges when N and P are diluted and accumulated in the plant as outlined in the QUEFTS model will result in two equations (YNP and YPN) below. The final yield estimate is the average value from the estimates of the two equations:

$$\begin{aligned}
 YNP = YPA & \\
 + \frac{2 \times (YPD - YPA) \times (UN - 5 - YPA/70)}{(YPD/21 - YPA/70)} & \\
 - \frac{(YPD - YPA) \times (UN - 5 - YPA/70)^2}{(YPD/21 - YPA/70)^2} & \tag{13}
 \end{aligned}$$

Table 2. Surface soil properties of pedons in Danayamaka and Kayawa

Pedon ¹ Land facet ²	Pedons Danayamaka				Kayawa			
	A H	B S	C S	D C	E H	F SLx	G S	H C
Sand g kg ⁻¹	230	550	440	530	190	670	390	400
Silt g kg ⁻¹	480	320	380	340	510	250	310	410
Clay g kg ⁻¹	290	130	180	140	300	80	300	190
pH 1:2.5 s/w ratio	4.5	4.0	5.4	4.5	4.8	4.7	5.6	4.8
Ca cmol(+) kg ⁻¹	7.6	2.7	4.6	1.8	7.1	1.6	5.8	3.2
Mg cmol(+) kg ⁻¹	1.6	0.6	1.3	0.6	2.2	0.4	1.1	0.8
Na cmol(+) kg ⁻¹	0.1	0	0	0	0	0	0	0.1
K cmol(+) kg ⁻¹	0.7	0.2	0.6	0.3	0.1	0.2	0.3	0.3
Mn cmol(+) kg ⁻¹	0.12	0.15	0	0.02	0.01	0.02	0	0.02
Ech. Acid. cmol(+) kg ⁻¹	0.3	1.2	0	1.0	0.2	0.3	0	0.1
ECEC cmol(+) kg ⁻¹	10.4	4.8	6.5	3.7	9.7	2.5	7.3	4.5
OC g kg ⁻¹	11.4	4.7	7.3	3.9	12.9	4.0	4.7	10.2
Olsen P mg kg ⁻¹	4.28	26.2	1.73	3.72	0.38	3.02	0.95	1.64
Soil depth cm	10	15	10	7	22	7	8	8

¹ Pedon A was classified (ISSS-FAO-ISRIC, 1998) as Hypomolli-Plinthic Gleysol (Dystric), B = Abrupti-Albic Plinthosol (Endoeutric), C = Profondi-Bathistagnic Luvisol (Ferric), D = Endoeutri-Petric Plinthosol, E = Eutri-Gleyic Fluvisol, F = Abrupti-Bathistagnic Lixisol (Profondic and Ferric), G = Profondi-Bathileptic Luvisol (Epiferric), H = Abrupti-Epipetric Plinthosol.

² Land facets as also defined in land systems map (Wall 1978): C = interfluvial crest, S = valley side, SLx = lower valley side, H = valley head.

$$\begin{aligned}
 YPN = YNA & \\
 & + \frac{2 \times (YND - YNA) \times (UP - 0.4 - YNA/600)}{(YND/97 - YNA/600)} \\
 & - \frac{(YND - YNA) \times (UP - 0.4 - YNA/600)^2}{(YND/97 - YNA/600)^2} \quad (14)
 \end{aligned}$$

Targeting combined use of FYM and mineral fertilizers at the village and NGS benchmark area scales

Using the modified QUEFTS model on georeferenced soil profile data (Table 2) provided for the research villages by Delauré (1998), the response of major soils along representative toposequences in Danayamaka and Kayawa was evaluated. For the NGS benchmark area scale, a methodology was developed on a 20,000 km² test area to assess the fertility status of major soils that would support the transfer of the combined use of FYM and mineral fertilizers.

To develop the prototype land information system, a subset of data generated through the Central Nigeria Project undertaken by the Land Resources Division (now the Land Resources Department Centre) of the UK between 1969 and 1977 at the scale of 1:250,000 (Bennett et al. 1977) and also a subset of data generated through the Balanced Nutrient Management (BNMS) Project (Iwuafor et al., 2002) were used. These include a land system map with geo-referenced soil profiles of upland soils within the Kaduna plains (Wall, 1978), accompanying reports on site characteristics, land use and related analytical data, and nutrient uptake and yield-prediction empirical models developed in this study. A land system is primarily a major geographic unit having a predominantly uniform geology, climate (past and present) and a characteristic soil association. A land system is defined as a group of closely related topographic units, usually small in number, that have arisen as a product of common geomorphic phenomena and are appropriate for mapping at 1:250,000 to

Table 3. Major characteristics of land systems

Land system	General landform	Area (km ²)	Number of profiles
413	Gently undulating plains with sporadic rocky hills. Facets are interfluvial crest (C) representing 15% of the area, valley side (S) representing 44% and lower valley side (SLx) representing 18%. Slope 0–13%.	1210	15
418	Gently undulating plains with sporadic rocky hills. Facet C represents 20% of the land area, S, 45% and SLx, 18%. Slope 2–9%.	156	10
421	Undulating plains. Facet C represents 30% of the area, S, 45% and SLx, 18%. Slope 2–4%	851	7
422	Gently undulating plains. Facet H (valley head) represents 1% of the area, C, 11%, S, 47%, and SLx, 19%. Slope 0–13%.	6699	78
425	Gently undulating plains. Facet S represents 72% of the area. Slope 2–11%.	716	6
426	Gently undulating plains. Facet I (ironpan cap) represents 3% of the area, C, 14% and S, 61%, slope 2–7%.	1018	15
429	Gently undulating plains. Facet C represents 28% of land area, S, 44% and SLx, 17%. Slope 0–11%.	1387	8
443	Gently undulating plains. Facet S represents 59% of area. Slope 2%.	270	1
444	Gently undulating plains with sporadic low hills. Facet C represents 12% of area, S, 39%, and SLx, 29%. Slope 2–4%.	526	5
445	Gently undulating plains. Facet C represents 18% of area, S, 52% and SLx, 25%. Slope 2–4%.	306	5
446	Gently undulating plains with sporadic rocky hills. Facet R (rock outcrop and rocky hills) represents 6% of the area, C 8%, S 49% and SLx 30%. Slope 2–9%.	888	16
447	Gently undulating plains. Facet C represents 14% of land area, S 52%, SLx 21%, and I 3%.	724	7
448	Gently undulating plains. Facet C represents 14% of area, SLx 17%, H 2% and S 60%. Slope 0–9%.	896	13
449	Gently undulating plains. Facet C represents 61% of land area, and SLx 28%. Slope 2–7%.	578	6
450	Gently undulating plains. Facet C represents 13%, and S 60%. Slope 2–7%.	611	5
451	Gently undulating plains. Facet H represents 3% of area, C 13%, S 52%, SLx 12%. Slope 0–4%	1339	19

1:1,000,000 (Mitchell and Howard, 1978). The descriptions of 16 land systems used in this study are presented in Table 3. The land systems were selected based on the availability of required information (especially soil analytical data) and represented a test area within the Zaria–Kaduna plains. The land systems are represented by numerical codes. The proportions of land systems represented by different land facets and the number of profiles with soil analytical data are also given.

A land system map (spatial information) representing land systems on Map sheet 'a' of the Kaduna plains and showing the geo-referenced soil profiles (Bennett et al., 1977) was digitized (Figure 3) while the attribute data on the profiles were entered in a spreadsheet using EXCEL. A total number of 216 georeferenced soil profiles that had been analyzed for soil chemical and physical properties were available. Land systems, soil profiles and corresponding properties were arranged in a relational manner. For each soil profile, we calculated the land qualities related to maize production (potential N and P supply capacities, susceptibility to crusting, moisture supply capacity and susceptibility to erosion) and used the modified QUEFTS model to estimate maize grain yields under zero input (no fertilizer or manure) management. The attribute database created in EXCEL was converted into a dBase file and imported into GIS (ArcView v. 3.2). This attribute dbase file was linked to the digitized land system map. Yield estimates for each land system was made taking into consideration the relative area of the land facets. Different weights were assigned to the soil profiles according to the proportion of the land system covered by the facet it belongs to.

The 16 land systems considered in this study were aggregated (pooled), based on yield into three land management units (LMU). Land management unit 1 (LMU1) has land systems with estimated yield ≤ 800 kg ha⁻¹, LMU2 has land systems with estimated yield between 800 and 1000 kg ha⁻¹ and LMU3 has land systems with yield > 1000 kg ha⁻¹. Yield was chosen as a criterion for grouping since it reflects the overall fertility status of the soil. The index of crusting (a measure of susceptibility to crusting) and susceptibility to erosion were used to suggest the employment of management practices that reduce crusting and soil erosion within some land management units. Estimated values of SN and SP for the delineated land management units were also provided.

The differences in the yield potential of the different land management units were tested statistically

using the analysis of variance technique (SAS Institute, 1999).

Results and Discussion

Soil properties of farmers' fields

Tables 4 and 5 show the physical and chemical properties of soils in selected farmers' fields. Sand content in the topsoil (0–10 cm) ranged from 403 to 700 g kg⁻¹ (with a mean of 610 g kg⁻¹ on interfluvial crest, 580 g kg⁻¹ on valley side, 630 g kg⁻¹ on lower valley side, 610 g kg⁻¹ on valley head and 400 g kg⁻¹ in valley bottom), while silt content ranged from 215 to 398 g kg⁻¹ (with a mean of 270 g kg⁻¹ on interfluvial crest, 290 g kg⁻¹ on valley side, 280 g kg⁻¹ on lower valley side, 270 g kg⁻¹ on valley head and 400 g kg⁻¹ in valley bottom) and clay, 84 to 264 g kg⁻¹ (with a mean of 120 g kg⁻¹ on interfluvial crest, 130 g kg⁻¹ on valley side, 90 kg ha⁻¹ on lower valley side, 120 g kg⁻¹

Table 4. Soil properties of farmers' fields in Danayamaka

Property	Range	Mean	SD	CV (%)
<i>0–10 cm</i>				
Sand (g kg ⁻¹)	545–655	608	35	6
Silt (g kg ⁻¹)	215–334	274	35	13
Clay (g kg ⁻¹)	70–157	118	23	19
OC (g kg ⁻¹)	4.1–6.6	5.1	0.8	16
Tot N (g kg ⁻¹)	0.3–0.6	0.5	0.11	20
pH (H ₂ O)	5.7–6.4	6.1	0.26	4
Avail. P (Olsen) mg kg ⁻¹	0.2–13.6	5.0	3.9	78
Ca cmol (+) kg ⁻¹ soil	1.6–2.9	2.2	0.4	18
Mg cmol (+) kg ⁻¹ soil	0.4–1.1	0.7	0.2	29
K cmol (+) kg ⁻¹ soil	0.1–0.7	0.3	0.1	33
Exch. Acid. cmol (+) kg ⁻¹ soil	0.3–1.0	0.7	0.4	57
ECEC cmol (+) kg ⁻¹ soil	2.8–5.3	4.1	0.7	17
<i>10–30 cm</i>				
Sand (g kg ⁻¹)	389–557	478	61	13
Silt (g kg ⁻¹)	171–410	275	66	24
Clay (g kg ⁻¹)	143–372	246	72	29
OC (g kg ⁻¹)	3.0–5.0	4.1	0.6	15
Tot N (g kg ⁻¹)	0.4–0.5	0.4	0.1	13
pH (H ₂ O)	5.7–6.2	5.9	0.2	3
Ca cmol (+) kg ⁻¹ soil	1.8–4.1	3.1	0.6	20
Mg cmol (+) kg ⁻¹ soil	0.4–1.8	1.1	0.3	31
K cmol (+) kg ⁻¹ soil	0.1–0.5	0.2	0.1	40
Exch. Acid. cmol (+) kg ⁻¹ soil	0.3–1.0	0.7	0.2	29
ECEC cmol (+) kg ⁻¹ soil	3.3–6.7	5.4	0.9	17

Table 5. Soil properties of farmers' fields in Kayawa

Property	Range	Mean	SD	CV (%)
<i>0–10 cm</i>				
Sand (g kg ⁻¹)	403–700	562	86	15
Silt (g kg ⁻¹)	216–398	300	62	21
Clay (g kg ⁻¹)	84–264	138	51	37
OC (g kg ⁻¹)	4.5–13.3	7.0	2.3	33
Tot N (g kg ⁻¹)	0.4–1.0	0.5	0.2	40
pH (H ₂ O)	5.6–7.4	6.1	0.56	9
Avail.P (Olsen) mg kg ⁻¹	1.3–15.3	6.0	4.2	70
Ca cmol (+) kg ⁻¹ soil	1.9–10.2	3.5	2.3	66
Mg cmol (+) kg ⁻¹ soil	0.4–1.2	0.6	0.2	33
K cmol (+) kg ⁻¹ soil	0.2–0.5	0.3	0.1	33
Exch. Acid. cmol (+) kg ⁻¹ soil	0.3–1.3	0.7	0.3	43
ECEC cmol (+) kg ⁻¹ soil	3.3–13.2	5.4	2.7	50
<i>10–30 cm</i>				
Sand (g kg ⁻¹)	357–605	480	72	15
Silt (g kg ⁻¹)	171–447	295	59	20
Clay (g kg ⁻¹)	147–372	225	58	26
OC (g kg ⁻¹)	4.1–6.7	4.8	0.9	20
Tot N (g kg ⁻¹)	0.3–0.6	0.4	0.1	20
pH (H ₂ O)	5.2–7.0	6.0	0.5	9
Ca cmol (+) kg ⁻¹ soil	1.6–6.4	3.5	1.5	42
Mg cmol (+) kg ⁻¹ soil	0.3–1.3	0.8	0.3	38
K cmol (+) kg ⁻¹ soil	0.1–0.5	0.3	0.1	41
Exch. Acid. cmol (+) kg ⁻¹ soil	0.3–2.0	0.8	0.4	53
ECEC cmol (+) kg ⁻¹ soil	3.3–8.7	5.6	1.6	28

SD = standard deviation and CV = coefficient of variation.

on valley head and 200 g kg⁻¹ in valley bottom). Surface soil textures were predominantly sandy loam. The soils had very high silt contents. Total nitrogen content ranged from 0.4–1.0 g kg⁻¹ (with a mean of 0.4 g kg⁻¹ on interfluvial crest, 0.5 g kg⁻¹ on valley side, 0.5 g kg⁻¹ on lower valley side, 0.6 g kg⁻¹ on valley head and 1.0 g kg⁻¹ in valley bottom), while organic carbon (OC) ranged from 4.1–13.3 g kg⁻¹ (with a mean of 5.4 g kg⁻¹ on interfluvial crest, 6.2 g kg⁻¹ on valley side, 5.1 g kg⁻¹ on lower valley side, 7.5 g kg⁻¹ on valley head and 13.3 g kg⁻¹ in valley bottom). The total N and organic carbon were generally low. Soil pH (in water) ranged from 5.6 to 7.4 (with a mean of 6 on interfluvial crest and valley side, 6.1 on lower valley side, 6.5 on valley head and 5.9 g kg⁻¹ in valley bottom). The soils were slightly acidic to neutral. The available P (Olsen) ranged between 0.2 and 13.6 mg kg⁻¹ (with a mean of 3.45 mg kg⁻¹ on interfluvial crest, 5.42 mg kg⁻¹ on valley side, 10.28 mg kg⁻¹ on lower valley side, 5.14 mg kg⁻¹ on valley head and 13.1 mg kg⁻¹ in valley bottom) representing very deficient to moderate P levels. Exchangeable K ranged from 0.1 to 0.7

cmol(+) kg⁻¹ soil (with a mean of 0.32 cmol(+) kg⁻¹ on interfluvial crest, 0.31 cmol(+) kg⁻¹ on valley side, 0.37 cmol(+) kg⁻¹ on lower valley side, 0.40 cmol(+) kg⁻¹ on valley head and 0.2 cmol(+) kg⁻¹ in valley bottom), while exchangeable Mg ranged from 0.4 to 1.2 cmol(+) kg⁻¹ soil (with a mean of 0.70 cmol(+) kg⁻¹ on interfluvial crest, 0.60 cmol(+) kg⁻¹ on valley side, 0.63 cmol(+) kg⁻¹ on lower valley side, 0.75 cmol(+) kg⁻¹ on valley head and 1.2 cmol(+) kg⁻¹ in valley bottom). Effective cation exchange capacity (ECEC) ranged from 2.8–13.2 cmol(+) kg⁻¹ soil (with a mean of 4.54 cmol(+) kg⁻¹ on interfluvial crest, 4.31 cmol(+) kg⁻¹ on valley side, 4.20 cmol(+) kg⁻¹ on lower valley side, 8.55 cmol(+) kg⁻¹ on valley head and 7.40 cmol(+) kg⁻¹ in valley bottom).

Soils in the NGS are formed from basement complex rocks overlain by aeolian deposits. The high silt content reflects the aeolian origin of the parent material. McTainsh (1984) reported that the north-easterly winds from the Sahara desert (Harmattan) is laden with dust (high in silt), which is deposited selectively, the coarser fractions closer to the source, and the finer fractions further away. The soil organic carbon and total N contents were low. This is a result of lack of long fertility-regenerating fallow periods (Jones and Wild, 1975). Also, the continuous removal of crop residue from the field as firewood, fencing material or livestock feed or the burning of farm residue as a method of land clearing (Smaling et al., 1997; Tian et al., 1993), must have contributed to the low OC status. Disruption of soil aggregates through soil tillage may also explain the low organic C and N content (Six et al., 2002). Generally, most soils were deficient in available P, considering 12 mg kg⁻¹ (Vanlauwe et al., 2002) as critical values for maize. The low available P status is partly due to low OC levels and low use of P fertilizers (Smaling, 1993) and a relatively higher P sorption when compared with soils of the derived savanna (Mokwunye et al., 1986). The soils were not limiting in K considering that 0.16 to 0.25 cmol kg⁻¹ is considered the critical range (Adeoye and Agboola, 1985). Similarly, exchangeable Mg was in ample supply. A range of 0.2–0.4 cmol(+) kg⁻¹ is considered critical for maize (Lombin, 1974; Adeoye and Agboola, 1985).

Response of major soils at the village scale to combined use of FYM and mineral fertilizers

Secondary data available in the NGS benchmark of Nigeria (Table 6) was first of all used to validate

Table 6. Data for validating yield–prediction model

Source	Clay g kg ⁻¹	OC g kg ⁻¹	Olsen P mg kg ⁻¹	pH in H ₂ O	N applied	P applied	Yield kg ha ⁻¹
Oikeh, 1996	120	5.3	8.3	5.1	90	26	2750
Vanlauwe et al., 1997	130	3.1	5.5	6.2	0	30	413
Yaro, 1994	170	10.5	2.7	5.8	0	0	1440
Yaro, 1994	170	10.5	2.7	5.8	40	20	2242
Yaro, 1994	170	10.5	2.7	5.8	80	40	2215
Uyovbisere et al., 2001	180	7.8	3.0	5.2	0	0	833

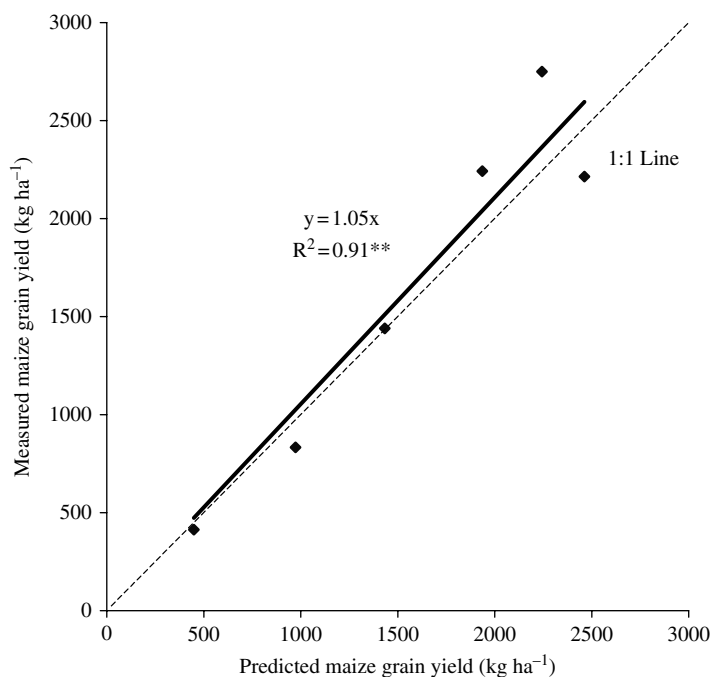

Figure 2. A comparison between predicted (using a modified QUEFTS model) and measured maize grain yield. Dotted line represents the 1:1 line.

the modified QUEFTS model. The results (Figure 2) indicated that predicted maize grain yields were in agreement with observed yields.

Table 7 shows the fertility capability classes (FCC) according to Sanchez et al. (2003), the native fertility status under zero input (potential to supply N and P and expected maize grain yield using the modified QUEFTS model) of major soils, and their response to combined application of FYM and mineral fertilizers (integrated nutrient management). Pedons D and F were of very low fertility status as indicated by their low potentials to supply N and P to the maize crop and consequently low grain yields. Soils of high fertility status could be found on upper and middle slope positions on the toposequence.

When yield prediction models are used together with the Fertility Capability Classification (FCC), the factors responsible for expected yield estimates would be better appreciated. The FCC is a suitable tool for the identification of limitations to crop production and is an important first step in developing a complete management plan for a farm, country or region. The five FCC classes of major soils in the benchmark area are interpreted below.

‘LChg’ (pedon A situated in valley head): Soils in this class have good water holding capacity and medium infiltration capacity. However, the low infiltration of the clayey subsoil may lead to ponding of the soil surface when flooded. Denitrification frequently occurs in anaerobic subsoil and tillage operations and

Table 7. FCC classes, and response of major soils to combined application of FYM and mineral fertilizers

Pedon	Land facet ¹	FCC	SN kg ha ⁻¹	SP kg ha ⁻¹	Yield kg ha ⁻¹ (no input)	Yield kg ha ⁻¹ (average input ²)
A	H	LChg	Not suited for maize (seasonal flooding)			
B	S	Lhed	22	14	910	1801
C	S	Lhed	38	3.8	940	1313
D	C	LChed	19	2.1	429	737
E	H	Lhg	Not suited for maize (seasonal flooding)			
F	SLx	Lhed	14	2.2	346	723
G	S	LChed	27	2.5	610	912
H	C	LRhed	53	2.3	803	812

¹ Land facets as also defined in land systems map (Wall 1978): C = interfluvial crest, S = valley side, SLx = lower valley side, H = valley head.

² INM = integrated nutrient management (45 kg N ha⁻¹ as urea, 45 kg N ha⁻¹ as FYM, 30 kg P ha⁻¹ as TSP).

excess rains may adversely affect certain crops unless drainage is improved. The anaerobic condition will favour the build up of undecomposed organic matter and consequently potential N and P supplies would be low. The soils have low-to-medium acidity. Potential N and P supply capacities as well as grain yield estimates were not made for this class as the seasonal flooding implies the land is not suitable for maize production. The proportion of the area covered by this group and other hydromorphic groups were not investigated.

'Lhed' (pedons B, C on valley side and pedon F on lower valley side): Soils in this class have good water holding capacity and medium infiltration rate. Moisture is limited during the dry season unless soil is irrigated. Planting date should take into account the flush of N at onset of the rains. Germination problems are often experienced if first rains are sporadic. Soils have low ability to retain nutrients mainly Ca and Mg; heavy applications of these nutrients and of N fertilizers should be split. The soils have low to medium acidity. The potential supply of N to maize crop (monocrop) ranged between 14 and 38 kg N ha⁻¹. The potential P supply capacity was high (14 kg P ha⁻¹) for pedon B and extremely low (3.8 and 2.2) for pedons C and F respectively. Expected maize grain yield under low input management (no fertilizer or manure application) ranged between 346 and 910 kg ha⁻¹ and under integrated nutrient management (45 kg N (urea) + 45 kg N (FYM) + 30 kg P (TSP) + 30 kg K KCl) the range was from 723 to 1801 kg ha⁻¹.

LChed (pedon D on interfluvial crest and pedon G on valley side): Soils in this class have good water holding capacity and medium infiltration rate. The soils are also susceptible to severe soil degradation from erosion exposing the clayey subsoil. Annual soil loss due

to water erosion could be high. A high priority should be given to erosion control. The mean potential N supply capacity of this class was 23 kg N ha⁻¹ and the mean potential P supply capacity was 2.3 kg P ha⁻¹. Expected maize grain yield under low input management is 429 kg ha⁻¹ and INM management is 737 kg ha⁻¹. The predicted P supply capacity of pedon G, which falls in this fertility class, is 2.5 kg P ha⁻¹ and the N supply is 27 kg N ha⁻¹. Expected mean maize grain yield under low input management is 516 kg ha⁻¹ and under INM is 775 kg ha⁻¹.

'Lhg' (pedon E on valley head): Soils in this class have good water holding capacity and medium infiltration capacity. Denitrification frequently occurs in anaerobic subsoil and tillage operations and excess rains may adversely affect certain crops unless drainage is improved. The anaerobic condition will favour the build up of undecomposed organic matter and consequently potential N and P supplies would be low. The soils have low-to-medium acidity.

'LRhed' (pedon H on interfluvial crest): Soils in this class have good water holding capacity and medium infiltration rate. The soils are also susceptible to severe soil degradation from erosion exposing the rocky layer. Soil loss was not estimated for this soil since no selected farmer's field was located nearby. A high priority should be given to erosion control. The rocky layer (+31 cm) in the subsoil would constitute a hindrance to root growth. Crops grown on such soils are not able to take advantage of the many attributes of deep rooting, such as a larger reservoir of available water and the ability to recycle nutrients leached from the topsoil (Sanchez et al., 2003). Soils in this class are deficient in available P and require supplemental P application. The potential P supply capacity of pedon H is 2.3 kg P ha⁻¹ and N supply is 53 kg N ha⁻¹. Although the

potential N supply capacity was on the high side, predicted yield was low indicating a clear dependence of response to N on soil P. Expected maize grain yield under low input management is 803 kg ha⁻¹ and under INM management is 812 kg ha⁻¹. Pedon H did not show any response to soil fertility management, suggesting nutrient imbalance and/or the negative effects of the rocky layer at +31 cm.

Scaling-up combined use of farmyard manure and mineral fertilizers within the NGS of Nigeria

A comparison of soil analytical data from soil survey conducted in 1977 for 16 selected land systems in the NGS benchmark area with recent information (Table 8) for the 2 research villages (Danayamaka and Kayawa in 1998), revealed that there were no marked differences in the ranges in soil properties considered between the two sets of data. The ranges were almost similar for both datasets. However, the upper limits of the ranges in soil properties were slightly higher for the historic than the recent dataset for most properties. Different soil: water ratios were used in the determination of pH in water. For the historic data the ratio was 1:5, while for the recent data it was 1:2.5. The difference in the upper limits in pH was 1.5 units; 4 g kg⁻¹ for OC, and 3

cmol_c kg⁻¹ for Ca. Available P was not analysed for during the survey in 1977. Bulk densities were higher for the recent data. Drainage conditions were similar but land use was completely arable for the recent data while some of the soil profiles of the 1977 data were under forest reserve, improved pasture, or uncultivated tree and shrub savanna. Generally, irrespective of datasets, soils were low in OC and total N contents. The soils were slightly acidic and also low in CEC. Topsoil textures were predominantly sandy loams underlain with sandy to clayey subsoil.

Figure 3 is a map showing land systems (LS) of a test area within the NGS. The numbers are identification numbers for the land systems and the different colours distinguish one land system from the other. Three land management units (Figure 4) were delineated within the test area (consisting of 16 land systems). The first class (LMU1) represents land systems where expected maize grain yield under low input soil fertility management (no fertilizers or manure) is never up to 800 kg ha⁻¹. Land systems 443, 444, 445, 449 and 450 belong to this class. A range in SN of 5–25 kg N ha⁻¹, SP of 1–3 kg P ha⁻¹ and maize grain yield of 574 (LS 450)–794 kg ha⁻¹ (LS 449) is expected within the class. The weighted average yield for LMU1 is 688 kg ha⁻¹ (Table 9). Most of the soils in this class are susceptible to crusting and to erosion. Members in class 2 (LMU2)

Table 8. A comparison of recent soil survey information for the NGS benchmark with historic survey information for land systems in which Danayamaka and Kayawa occur

Soil properties (Ap Horizon)	Range in soil properties (4–32 cm depth)	
	Recent survey ¹ n = 8	Historic survey ² n = 78
pH (in water) ³	4.0–6.7	4.5–8.2
Total N (g kg ⁻¹)	0.4–1.2	0.3–1.3
OC (g kg ⁻¹)	3.9–12.9	2.3–17
Na (cmol+ kg ⁻¹)	0–0.1	0–0.1
Mg (cmol+ kg ⁻¹)	0.4–2.2	0–4.1
Ca (cmol+ kg ⁻¹)	2.7–7.6	0–11.2
K (cmol+ kg ⁻¹)	0.1–0.7	0–0.9
CEC (cmol+ kg ⁻¹)	3–15.1	1.5–14.5
Bray 1 P (mg kg ⁻¹)	0.6–41.8	Not analysed
Bulk density (g cm ⁻³)	1.13–1.59	0.93–1.54
Drainage	Poor, imperfect, well–drained	Poor, imperfect, well–drained
Land use	Arable	Arable, fallow, forest reserve, grassland, improved pasture, tree and shrub savanna

¹ Delauré (1998).

² Unpublished data from the study reported by Bennett et al. (1977).

³ pH was analyzed in 1:5 soil / water ratio for the historic data.

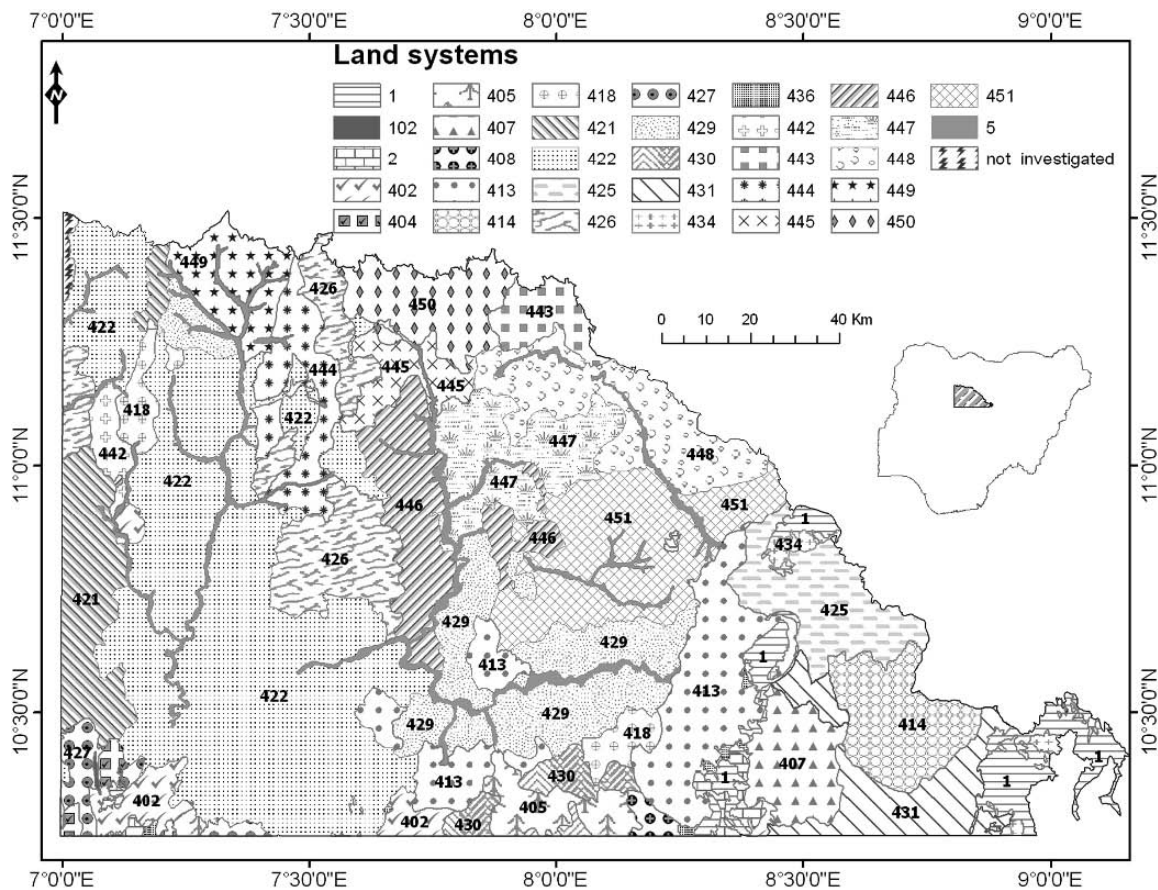

Figure 3. Map showing land systems in the study area. (Source: Wall 1978). The land systems were described in Table 3.

Table 9. Predicted maize grain yield (with no fertilizer input) for delineated land management units within the NGS benchmark area

Land management unit (LMU)	Mean maize grain yield (kg DM ha ⁻¹)
LMU1	688
LMU2	946
LMU3	1382
Standard Error	40.47

are land systems 418, 421, 443, 446, 447 and 448. Here, a range in SN of 2–57 kg N ha⁻¹, SP of 1–5 kg P ha⁻¹ and maize grain yield of 912 (LS 448)–992 kg ha⁻¹ (LS 447) is expected. A weighted average yield for LMU2 is 946 kg ha⁻¹. Class 3 (LMU3) consists of land systems 413, 422, 425, 426, 429 and 451. A range in SN of 23–50 kg N ha⁻¹, SP of 2–4 kg P ha⁻¹ and maize grain yield of 1058 (LS 413)–1530 kg ha⁻¹ (LS 422) is expected within the class. A weighted average yield

of for this class is 1382 kg ha⁻¹. Maize grain yield estimated for LMU3 was two times that for LMU1 and 1.5 times that for LMU2. The area in Fig. 4 defined as ‘not defined’ are land systems with more than 50% of their area outside sheet ‘a’ of the land system map considered in this study. Land management units 1, 2 and 3 were significantly different ($P < 0.05$) in terms of their yield potential.

Mitchell and Howard (1978) had recognized that land systems with certain affinities in common could be grouped into larger / compound land systems. Information available for the land systems delineated by Wall (1978) provided a rapid synopsis of the land resources of the area under study so that research effort can be more effectively deployed. It provided a general inventory, which also gives a framework on which more detailed information could be fitted to make practical predictions and for planning agro-technology transfer. Quantitative information on land qualities related to maize production and maize grain yield estimates

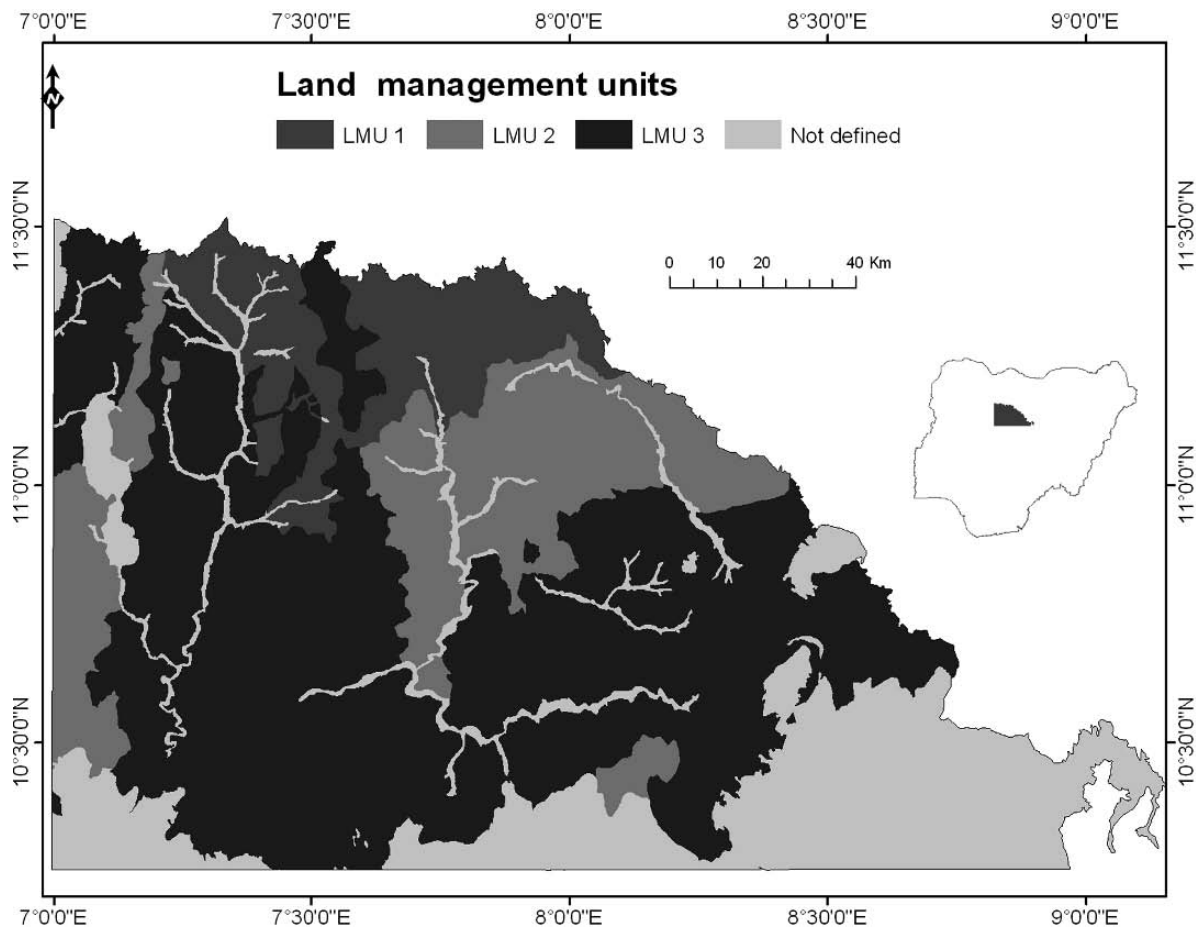

Figure 4. Land management units delineated in the study area.

under different levels of soil fertility management for the land management units are now available. Earlier reports on the land resources of the Kaduna plains (Bennett et al., 1977) did not carry such information. Of major importance is that the procedure outlined in the delineation of land management units took into consideration all the different soil types encountered within each land system, hence accounting adequately for soil spatial variability. The methodology described here for delineating land management units could be used on larger areas.

The range in SN and SP as well as the yield estimates for the different land management units delineated are comparable with those observed on major soils (that showed response to INM technology) in the NGS benchmark providing a basis for direct transfer of the INM technology 45 kg N ha^{-1} (urea) + 45 kg N ha^{-1} (FYM) + 30 kg P ha^{-1} (TSP) for the larger northern Guinea savanna area. However, the responses of the

three land management units to the INM technology would vary. The highest response would be expected on LMU1 and the least on LMU3. The highest grain yields expected in LMU3 is a reflection of a higher nutrient supplying power of the soils in this unit. Land management unit 1 should be a priority area in targeting the INM technology defined above, with measures to reduce surface crusting and to control soil taken into consideration.

Conclusion

Major soils in the NGS benchmark area are responsive to combined use of FYM and mineral fertilizers. Based on the similarity in native soil fertility status and other crop production constraints (provided by the land information system developed) of the larger NGS

area with that of the benchmark, response to INM technology is expected in the larger target area. Although a general response to INM technology is expected, response would be highest in LMU1 (if measures to check erosion and to reduce surface crust are taken into consideration) and least in LMU3.

Acknowledgements

We are grateful to the Belgian Administration for development Cooperation (DGIC), for sponsoring this work as part of the collaborative project between KU Leuven, Leuven and IITA on 'Balanced Nutrient Management Systems for Maize-based farming Systems in the Moist Savanna and Humid Forest Zone of West-Africa'

References

- Adeoye G.O. and Agboola A.A. 1985. Critical levels for soil pH, available P, K, Zn, and Mn and maize earleaf content of P, Cu and Mn in sedimentary soils of southwestern Nigeria. *Fert. Res.* 6: 65–71.
- Amato M. 1983. Determination of carbon ^{12}C and ^{14}C in plant and soil. *Soil Biol. Biochem.* 15: 611–612.
- Bationo A., Buerkert A., Sedogo M.P., Christianson B.C. and Mokwunye A.U. 1995. A critical review of crop-residue use as soil amendment in the West African semi-arid tropics. In: Powell J.M., Fernández-Rivera S., Williams T.O. and Renard C. (Eds), *Livestock and sustainable nutrient cycling in mixed farming systems of sub-Saharan Africa. Volume 2: Technical papers. Proceedings of and International Conference, ILCA, Addis Ababa, Ethiopia, 22–26 November 1993. International Livestock Centre for Africa (ILCA), Addis Ababa, Ethiopia*, pp. 305–322.
- Beek K.J., Driessen P. and De Bie K. 1997. Land information and land evaluation for land use planning and sustainable land management. *Land (Chatham)* 1: 27–44.
- Bennett J.G. 1980. Aeolian deposition and soil parent materials in Northern Nigeria. *Geoderma* 24: 241–255.
- Bennett J.G., Hutcheon A.A., Kerr W.B., Mansfield J.E. and Rackham L.J. 1977. Land resources of central Nigeria. Environmental aspects of the Kaduna plains. Vol. 1. Landforms and soils. Land Resources Report No. 19. Land Resources Division, Tolworth Tower, Surbiton, Surrey, England. 277p.
- Bouyoucos G.J. 1962. Hydrometer method improved for making particle size analysis of soils. *Agron. J.* 54: 464–465.
- Burrough P.A. 1986. Principles of geographic information systems for land resources assessment. Clarendon Press, Oxford, United Kingdom, 191pp.
- Deckers J. 2002. A system approach to target balanced nutrient management in soils of sub-Saharan Africa. In: Vanlauwe B., Diels J., Sanginga N. and Merckx R. (Eds) *Integrated Plant Nutrient Management in Sub-Saharan Africa: From Concept to Practice*. CABI publishing in association with the International Institute of Tropical Agriculture, Wallingford, UK. pp. 47–61.
- de la Rosa D., Moreno J.A., Garcia L.V. and Almora J. 1992. MicroLEIS: A microcomputer-based Mediterranean land evaluation information system. *Soil Use Manage.* 8: 89–96.
- Delaure S. 1998. Soil survey of two pilot villages in the NGS benchmark area of Nigeria. Ag. Eng. Thesis, Katholieke Universiteit, Leuven, Belgium, 110pp.
- Dudal R. 2002. Forty years of soil fertility work in sub-Saharan Africa. In: Vanlauwe B., Diels J., Sanginga N. and Merckx R. (Eds), *Integrated plant nutrient management in sub-Saharan Africa: From concept to practice*. CAB International, Wallingford, Oxon, UK., pp. 7–21.
- FAO 1979. A provisional methodology for soil degradation assessment. Food and Agricultural Organization of the United Nations (FAO), Rome, Italy. 84 p.
- Graef F., Duivenbooden N.v. and Stahr K. 1998. Remote sensing and transect-based retrieval of spatial soil and terrain (SOTER) information in semi-arid Niger. *J. Arid Environ.* 39: 631–644.
- Heineke H.J., Eckelmann W., Thomasson A.J., Jones R.J.A., Montanarella L. and Buckley B. 1996. Land Information Systems—Developments for planning the sustainable use of land resources. Proceedings of a European Union (EU) workshop, November, 1996, Hannover, Germany. 547 pp.
- Honlonkou A.N., Manyong V.M. and Tchetché N. 1999. Farmers' perceptions and the dynamics of adoption of a resource management technology: the case of Mucuna fallow in southern Benin, West Africa. *The International Forestry Review* 1: 228–235.
- Hoosbeek M.R. and Bryant R. 1992. Towards the quantitative modeling of pedogenesis: a review. *Geoderma* 55: 183–210.
- Igué A.M., Gaiser T. and Stahr K. 2004. A soil and terrain digital database (SOTER) for improved land use planning in Central Benin. *Eur. J. Agron.* 21: 41–52.
- IITA 1982. Selected methods for soil and plant analysis. Manual series No. 1, International Institute of Tropical Agriculture (IITA), Ibadan, Nigeria.
- ISSS-FAO-ISRIC 1998. World reference base for soil resources. World soil resources report, 84. Food and Agriculture Organization of the United Nations, Rome, Italy, 88 pp.
- Iwuafor E.N.O., Aihou K., Jaryum J.S., Vanlauwe B., Diels J., Sanginga N., Lyasse O., Deckers J. and Merckx R. 2002. On-farm evaluation of the contribution of sole and mixed applications of organic matter and urea to maize grain production in the savanna. In: Vanlauwe B., Diels J., Sanginga N. and Merckx R. (Eds), *Integrated plant nutrient management in sub-Saharan Africa: From concept to practice*. CAB International, Wallingford, Oxon, UK., pp. 185–197.
- Jagtap S.S. 1995. Environmental characterization of the moist savanna of Africa. In: Kang B.T., Akobundu I.O., Manyong V.M., Carsky R.J., Sanginga N. and Kueneman E.A. (Eds.), *Moist savannas of Africa. Proc. of an IITA/FAO workshop, 19–23 September 1994, Cotonou, Benin. International Institute of Tropical Agriculture, Ibadan, Nigeria*, pp. 9–30.
- Janssen B.H., Guiking F.C.T., van der Eijk D., Smaling E.M.A., Wolf J. and van Reuler H. 1990. A system for quantitative evaluation of the fertility of tropical soils (QUEFTS). *Geoderma* 46: 299–318.
- Jones M.J. and Wild A. 1975. Soil of the West African Savanna. Technical Communication of the Commonwealth Bureau of Soils No 55. Commonwealth Agricultural Bureau, Harpenden, UK.

- Keatinge J.D.H., Breman H., Manyong V.M., Vanlauwe B. and Wendt J. 2001. Sustaining soil fertility in West Africa in the face of rapidly increasing pressure for agricultural intensification. In: Tian G., Ishida F. and Keatinge J.D.H. (Eds), Sustaining Soil Fertility in West Africa. SSSA Spec. Publ. No. 58, Soil Science Society of America, Madison, Wisconsin, USA, pp. 1–22.
- Lombin L.G. 1974. Assessment of the magnesium potential of some Nigerian soils. Ph.D. Thesis, Agronomy Department, University of Ibadan, Nigeria.
- Magoggo J.P. 1989. A soil information system for Tanzania. In: J. Bouma and A.K. Bregt (Eds) Land qualities in space and time. Proceedings of a symposium organized by the International society of soil Science (ISSS), Wageningen, The Netherlands, 22–26 August 1998. pp. 105–108.
- Manyong V.M., Makinde K.O., Sanginga N., Vanlauwe B. and Diels J. 2001. Fertiliser use and definition of farmer domains for impact-oriented research in the northern Guinea savanna of Nigeria. *Nutr. Cycl. Agroecosyst.* 59: 129–141.
- McCurry P. 1970. Geology. In: Mortimore M.J. (ed.) Zaria and its region. Occasion Paper No 4 Department of Geography, Ahmadu Bello University, Zaria, Nigeria, pp. 5–12.
- Mctainsh G.H. 1984. The nature and origin of aeolian mantles of central Northern Nigeria. *Geoderma* 48: 113–129.
- Mitchell C.W. and Howard J.A. 1978. Land system classification a case history: Jordan. Revision of 1975 report prepared for the Food and Agriculture Organization of the United Nations. *AGLT Bulletin* 2/78, Rome. 124p.
- Moberg J.P. and Esu I.E. 1991. Characteristics and composition of some savanna soils in Nigeria. *Geoderma* 48: 113–129.
- Mokwunye A.U., Chien S.H. and Rhodes E. 1986. Phosphate reactions with tropical African soils. In: Mokwunye A.U. and Vlek P.L.G. (Eds) Management of nitrogen and phosphorus in sub-Saharan Africa. Martinus Nijhoff, The Hague, Netherlands, pp. 253–281.
- Murphy J. and Riley J. 1962. A modified single solution method for the determination of phosphate in natural waters. *Anal. Chim. Acta* 27: 31–36.
- Mutsaers H.J.W., Weber G.K., Walker P. and Fisher N.M. 1997. A field guide for on-farm experimentation, IITA/CTA/ISNAR, Ibadan, Nigeria, 233 pp.
- Nil D. 1993. Soil erosion from natural and simulated rain in forest, savannah and highland areas of humid to sub-humid West Africa and influence on management. Ph.D. Thesis, Technische Universitat Munchen. 270p.
- Oikeh S.O. 1996. Dynamics of soil nitrogen in cereal-based cropping systems in the Nigerian Savanna. Ph.D. Thesis. Faculty of Agriculture, Amadu Bello University Zaria, Nigeria. 194 p.
- Okalebo J.R., Gathua K.W. and Woome P.L. 1993. Laboratory methods of soil and plant analysis: a working manual. Tropical Soil Biology and Fertility Programme, Nairobi, Kenya, 88 p.
- Oldeman L.R. and van Engelen V.M.P. 1993. A world soils and terrain digital database (SOTER). *Geoderma* 60: 309–325.
- Roose E. and Sarrailh J.M. 1989. Erodibilité de quelques sols tropicaux. Vingt années de mesure en parcelles d'érosion sous pluies naturelles. *Cahier. Orstom, Serie. Pedologie.* 25(1–2): 7–30.
- Sanchez P.A., Palm C.A. and Buol S.W. 2003. Fertility capability soil classification: a tool to help assess soil quality in the tropics. *Geoderma* 114: 157–185.
- SAS Institute 1999. SAS user's guide. SAS Inst., Cary, N.C., USA.
- Schulze R. 2000. Transcending scales of space and time in impact studies of climate change on agrohydrological responses. *Agric. Ecosyst. Environ.* 82: 185–212.
- Searle P.L. 1984. The Berthelot or indophenol reaction and its use in analytical chemistry of nitrogen. A review. *Analyst (London)* 109: 549–568.
- Six J., Feller C., Denef K., Ogle S.M., de Moraes Sa J.C. and Albrecht A. 2002. Soil organic matter, biota and aggregation in temperate and tropical soils – Effects of no-tillage. *Agronomie* 22: 755–775.
- Smaling E.M.A. 1993. An agro-ecological framework for integrated Nutrient Management with special reference to Kenya. Ph.D. thesis (published) Wageningen Agricultural University, Wageningen, The Netherlands, 250 p.
- Smaling E.M.A., Nandwa S.M. and Janssen B.H. 1997. Soil fertility in Africa is at stake. In: Buresh R.J., Sanchez P.A., Calhoun F. (eds) Replenishing soil fertility in Africa. SSSA Special Publication 51, SSSA, ASA, Wadlington, USA, pp. 47–61.
- Tabi F.O. 2004. The development of a land information system in the northern Guinea savanna of Nigeria as a basis for agro-technology transfer. Ph.D Thesis, University of Ibadan, Ibadan, Nigeria, 228 pp.
- Tian G., Kang B.T. and Brüssard L. 1993. Effect of plant residue with chemically contrasting composition on maize growth and nutrient composition on maize growth and nutrient concentration. *Plant Soil* 153: 179–187.
- Tian G., Kolawole G.O., Kang B.T. and Kirchhof G. 2000. Nitrogen fertilizer replacement indexes of legume cover crops in the derived savanna of West Africa. *Plant Soil* 224: 287–296.
- Uyovbisere E. O., Elemo K.A. and Tarfa B.D. 2001. Effect of foliage of locust bean (*Parkia biglobosa*) and neem (*Azadirachta indica*) on soil fertility and productivity of early maize in asavanna Alfisol. In Badu-Apraku B., Fakorede M.A.B., Ouedraogo M. and Carsky R.J. (Eds) Impact, challenges and prospects of maize research and development in West and Central Africa. Proceedings of a regional maize workshop 4–7 May 1999, IITA-Cotonou, Benin Republic, pp. 185–194.
- Vanlauwe B., Diels J., Lyasse O., Sanginga N., Deckers S. and Merckx R. 1997. Balanced nutrient management systems in the moist savanna and humid forest zone of West Africa. Annual report No. 1. International Institute of Tropical Agriculture, Ibadan, Nigeria.
- Vanlauwe B., Aihou K., Aman S., Iwuafor E.N.O., Tossah B.K., Diels J., Sanginga N., Lyasse O., Merckx R. and Deckers J. 2001. Maize yield as affected by organic inputs and urea in the West-African moist savanna. *Agron. J.* 93: 1191–1199.
- Vanlauwe B., Diels J., Lyasse O., Aihou K., Iwuafor E.N.O., Sanginga N., Merckx R. and Deckers J. 2002. Fertility status of soils of the derived savanna and northern guinea savanna benchmarks and response to major plant nutrients, as influenced by soil type and land use management. *Nutr. Cycl. Agroecosyst.* 62: 139–150.
- Wall J.R.D. 1978. Land resources of central Nigeria. Agricultural development possibilities, vol. 5, the Kaduna Plains (maps). Land Resources Development Centre, Tolworth Tower, Surbiton, Surrey, England.
- Williams T.O., Powell J.M., Fernández-Rivera S. and Renard C. 1995. Manure utilization, drought cycles and herd dynamics in the Sahel: Implications for cropland productivity. In:

Powell J.M., Fernández-Rivera S., Williams T.O. and Renard C. (Eds), Livestock and sustainable nutrient cycling in mixed farming systems of sub Saharan Africa. Volume 2: technical papers. Proceedings, of an international conference held in Addis Ababa, Ethiopia, 22–26 November 1993. International Livestock Centre for Africa (ILCA), Addis Ababa, Ethiopia, pp. 393–409.

Wischmeier W.H. and Smith D. 1978. Predicting rainfall erosion losses – A guide to conservation planning. US Government printing office, Washington DC, USA.

Yaro D.T. 1994. The use of organic manure supplemented with inorganic fertilizer in crop production in the northern guinea savanna zone of Nigeria. MSc Thesis, Ahmadu Bello University, Zaria–Nigeria, 136pp.

What role can planted fallows play in the humid and sub-humid zone of West and Central Africa?*

Stefan Hauser^{1,3,*}, Christian Nolte¹ and Robert J. Carsky^{2,†}

¹International Institute of Tropical Agriculture, Humid Forest Ecoregional Centre, Mbalmayo, Yaoundé, Cameroon; ²Africa Rice Center (WARDA), Bouaké, Côte d'Ivoire; ³L.W. Lambourn & Co, Carolyn House, 26 Dingwall Road, CR9 3EE, Croydon, UK; *Author for correspondence (e-mail: s.hauser@cgiar.org; fax: +237-2237-437)

Key words: Crop yield response, Herbaceous, Leguminous fallow, Soil fertility replenishment, Tree-based

Abstract

Crop management without fertilizer input, which is commonly practiced by most farmers in the humid forest zone of West and Central Africa, requires soil fertility replenishment during a fallow period. Hypothetical relationships between fallow length and crop yields assume, that after the cropping phase replenishment starts with high annual increments, leading to an early recovery of most soil fertility, then slowly approaching a maximum level. The few available empirical data, however, indicate that this assumption is wrong. Within the first 8 years of fallow, biomass and nutrient accumulation is either progressive (low initial increments) or linear. Planted fallows are supposed to replenish soil fertility faster or to higher levels than natural regrowth and should thus lead to higher crop yields. Two major types of planted fallow are distinguished: tree-based and herbaceous fallows. Data from West and Central Africa do not confirm that tree based fallows are generally capable of attaining higher crop yields than natural regrowth or other planted fallows. The majority of experiments with tree-based fallows showed no differences to the control (60.0%). Crop yield declines were found in 15.7% of cases, and only 24.3% resulted in significant yield increases. Changes in soil properties were more frequently positive (34.3%) than negative (9.8%), yet, most often (55.9%), there was no effect. Herbaceous fallow had dominantly positive effects on crop yields (52.5% of cases), with only 3% of cases in which significant reductions were observed. Positive features of some herbaceous fallows, such as easy establishment, rapid weed suppression, and labor efficient slash-and-burn crop establishment make the technology more likely to be accepted and adopted by farmers. It appears that fallows have to be specifically designed for responsive crops, i.e. maize. It is unlikely that one type of fallow can serve the multitude of crops and intercrops grown in the region. Depending on the major constraints to crop production or income generation, planted fallows have to be specifically designed to address these constraints. This may require de-emphasizing the soil fertility aspect and focusing on marketable fallow by-products, weed and pest suppression and reduced labor requirements. Thus, future impact through research on planted fallows will depend on exact targeting of specific fallow types and species to the most responsive crops and to explicit farmer circumstances.

† Deceased.

*This paper is dedicated to Dr. Robert J. Carsky, who was killed on November 6, 2004 at Bouaké, Côte d'Ivoire, when he was seeking shelter during a bombing raid.

This article has been previously published in the journal "Nutrient Cycling in Agroecosystems" Volume 76 Issues 2–3.

Introduction

The Humid Forest zone of West and Central Africa encompasses about 250 million hectares of land and is the largest eco-zone in the region. It is estimated that over 100 million people now live in its urban and rural areas (J. Gockowski, IITA, Humid Forest Eco-regional Center Yaoundé Cameroon, personal communication), which equals an average population density of 40 people km^{-2} , however, with tremendous variation from >1000 in parts of south-east Nigeria to 0–4 people km^{-2} in remote parts of the Congo Basin.

Agriculture in the humid forest zone of West and Central Africa is still largely based on the traditional slash and burn system with natural fallow vegetation. If the fallow period in this system is long enough relative to the cropping period it is sustainable. Nye and Greenland (1960) related sustainability of this system directly to population density and estimated the limit at 7.8 people km^{-2} . Laudelout (1990), who summarized fallow research work from the first half of the 20th century at Yangambi, DR Congo, gives a figure of 20 people per km^2 along with a minimum fallow period of 12 years for the Congo Basin. Twelve years of fallow no longer is an option in large areas of West and Central Africa's forest zone because population density exceeds 20 people km^{-2} . In the forest margins of Cameroon, for example, the mean fallow period in areas around Yaoundé with 70–80 people km^{-2} is 3.9 years (Gockowski et al. 2004). It can therefore be assumed that soil fertility is in decline and crop yields will decrease.

Many attempts have been undertaken over the last 70 years to find technologies that could halt that decline. Planting fallows with trees, shrubs and herbaceous plants has been one of the most widely tested options with the intention of restoring soil fertility faster than under natural vegetation. The hypothetical functions, processes and capabilities of planted fallows have been extensively described and cited (Kang et al. 1989), were modeled (Vandermeer 1998), partially found to be actually existing or occurring, yet some remain questionable or still have to be proven of making a significant contribution toward system maintenance (Hauser et al. 2005). Adoption of planted fallow systems, specifically tree-based fallows or continuous alley cropping systems, was low under

all circumstances. Dvorák (1991) reported from south-western Nigeria, that no farmer expanded alley cropping plots, initially set up with the help of researchers. No farmer established alley cropping plots on his own and no neighbouring farmer picked up the technology from another farmer. Later surveys showed that a small number of farmers, 21 out of 139 surveyed and previously exposed to alley cropping, had planted alley cropping systems yet, that about 47% had already abandoned it (Adesina and Chianu 2002). Similar results were obtained in southern Bénin (Douthwaite, IITA, Ibadan, Nigeria, personal communication). Thus, none of the systems developed and tested is currently used at a large scale by farmers, raising the question whether soil fertility decline is not yet a concern, whether planted fallows are not performing sufficiently well or if problems with implementation and use prevent large scale adoption.

This paper is an attempt to summarize primarily crop yield results of on-station and on-farm experiments on planted fallow and compare them with those attained in natural regrowth fallows in West and Central Africa. The objective is to evaluate if planted fallows are capable to restore soil properties faster or to higher levels than other fallow types, and if such advantages are reflected in crop yield increases over the level of the natural fallow.

Materials and methods

We gathered a fair amount of information but cannot claim to have accessed and analysed the complete set for West and Central Africa. Oikeh (1999) has compiled the results of IITA experiments on resource and crop management technologies. His compilation includes material from annual reports, which is not considered here, as it is difficult to avoid results being used several times if they are published elsewhere. For the few cases in which annual or unpublished reports were used, we made sure that the same information was not published elsewhere and thus counted twice. However, the frequency distribution of soil and crop yield responses might shift if more results were incorporated.

The frequency distributions of crop yield responses to the different fallows were calculated by

copying all available data from the publications into a Microsoft Excel work sheet, classified by the level of response into significant increase, neutral and significant decrease. In case the statistics were not available, yields exceeding the control by >20% were considered increases and yields >20% lower were considered decreases. Whenever no yield data were provided yet the response, we included the information in overall crop response frequency distributions.

The relative (%) and absolute (Mg ha^{-1}) crop yield responses were calculated from the sum of all control yields per crop compared to the sum of all yields in planted fallows. When data were presented in figures rather than tables we estimated the yield figures in such a way that visible differences would be reflected in the data, yet we cannot ensure complete accuracy of these numbers.

Methodological problems associated with research on tree based fallow/food crop systems

Neither the above nor the below-ground portions of trees can securely be confined within plot boundaries. Such properties of trees are obvious and they should have been considered from the early stages of research on tree-based fallows. Only a few publications point out that it is inappropriate to assume that trees remain with their roots inside the allocated plots and that there is no interference with other plots or the unused surrounding (Hauser 1993a; Hauser and Gichuru 1994; Coe 1994). Further, it has not been considered that tree canopies may exceed the plot boundaries and expose larger areas of canopy for photosynthesis than would be possible within the area allocated. Observations in a long-term experiment at IITA, Ibadan, south-western Nigeria, showed that *L. leucocephala* in the second and third year of fallow expanded the canopy by more than three meters beyond the plot boundaries. Plots measured 12 by 20 m thus were 240 m² large (Chikoye et al. 2000). Growth beyond the plot borders effectively doubled the surface area of the plots to about 470 m². Both processes, root and canopy expansion, give trees access to resources beyond the plot boundaries. Overestimation of the potentials of tree-based fallows is the consequence.

Mechanical control and enforcement of plot borders for the roots, is problematic, as it would require trenching or the insertion of physical barriers. The latter is usually impossible for technical reasons and any barrier not reaching the maximum rooting depth, will become inefficient after some time (Hauser and Gichuru 1994; Liya 1994; Ong 1996). Plastic sheets were pierced by tree roots (Schroth and Zech 1995a). Although interference could occur, Schroth et al. (1995b) found no differences in crop yields between plots trenched to 0.9 m depth with plastic sheet and plots without root barriers. Hauser and Gichuru (1994) found higher maize and cassava yields when metal sheet barriers to 0.7 m depth were installed around no-tree control plots than in no-tree control plots without barriers. The control of aboveground material appears to be more practical, however, regular pruning will be required to contain the tree branches within the confines of a plot. No information could be found on the amount of tree fallow biomass produced outside allocated plot boundaries.

In other fallow types, this kind of methodological problems may exist, yet no indication of serious experimental errors could be found. Herbaceous, shrubby and grass fallows can easily be retained within plot borders. Their roots may grow outside the plot yet there are no reports that large distances can be covered.

One of the most commonly tested tree-based systems is alley cropping (Kang et al. 1981, 1984), where food crops are grown between hedgerows of trees or shrubs. The hedgerows are pruned to reduce competition and to provide mulch. In alley cropping, one hedgerow is allocated to one interrow space (Figure 1a and b). The hedgerows can be located in the middle of the interrow space and prunings be divided to the left and right (Figure 1a). Crops are planted in all interrow spaces but yield determinations may be restricted to areas bordered by hedgerows. Another design would have one hedgerow to the left or right of an interrow space and the prunings spread to the respective interrow space (Figure 1b). Unfortunately, a large number of experiments were established with a hedgerow at both ends of the plots, thus, with one hedgerow more than interrow spaces (Figure 1c). Consequently one excess hedgerow was competing with and providing mulch to the cropped area. Experimental results

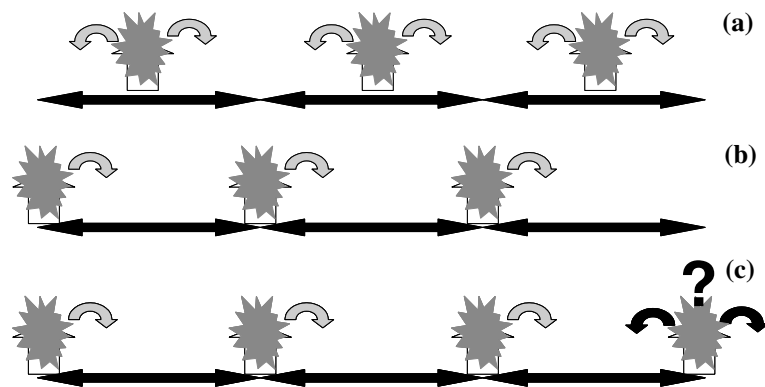

Figure 1. Schematic demonstration of hedgerow vs. interrow arrangement and pruning application. (a) Hedgerows in middle of interrow space, prunings equally split to both sides; (b) hedgerows at one side of interrow space, prunings applied to one side; (c) hedgerows to either side of interrow spaces with one hedgerow in excess and questionable application of prunings (black arrows at the right).

have to be considered inaccurate, if such designs were used and they are flawed if prunings of such border rows were retained in the cropped area. While in some cases the prunings of such additional border rows may have been discarded or kept outside the cropped area, it is uncertain if and how water and nutrient regimes and balances may have been biased under such conditions and what effect this had on soil properties and crop yields.

Trees, no matter what planting pattern, require space. Two methods exist of adapting crop density to the space taken by trees: (1) replacing crop space by tree space, i.e., reduce crop density and (2) adding the trees to the crops, i.e., keeping the same crop density. In the former case, the number of crop plants is reduced according to the space taken by the trees. Important is that there is no reduction in the number of crop plants in any other tested alternative systems and the no-tree control, relative to the tree-based system. Reducing crop density in the no-tree control (see Siaw et al. 1991) by a proportion equivalent to the space taken by trees in tree-based systems imposes an intentional disadvantage on alternative systems and the no-tree control. Any reduction in crop density in control systems is equivalent to discounting the space taken by trees and will inevitably result in erroneous overestimation of the relative advantage of tree-based systems.

We will not further investigate the consequences and impact of these methodological problems, yet a number of grave errors potentially affect a large

proportion of the published results. Many publications do not provide all information on the methodology and procedures used, to determine whether precautions were taken to prevent or minimise errors. In some cases methodological shortcomings in experimental designs were obvious. Such data were not used when the reported variables were susceptible to experimental bias. Thus the data in Tables 1–5, summarizing the general responses in crop yields and soil properties should be interpreted with some caution.

Future research on tree-based fallow systems should more consciously take into account methodological problems. It may be appropriate to define a set of essential measures to be taken when working with tree-based systems, to reduce experimental errors.

The fallow length – soil fertility regeneration relationship

A basic concept of the relationship between fallow length and soil fertility regeneration was published as ‘Van der Pool’s curves’ by Guillemin (1956) and later used by Sanchez (1976), Ruthenberg (1980), and more recently by Beets (1990) (Figure 2). The assumption is that after cropping soil fertility or fertility related parameters increase at high initial rates and asymptotically approach a maximum. At low population densities full fertility recovery will be attained, followed by a non-essential fallow phase (Type 1 scenario, Figure 2). Sustainable

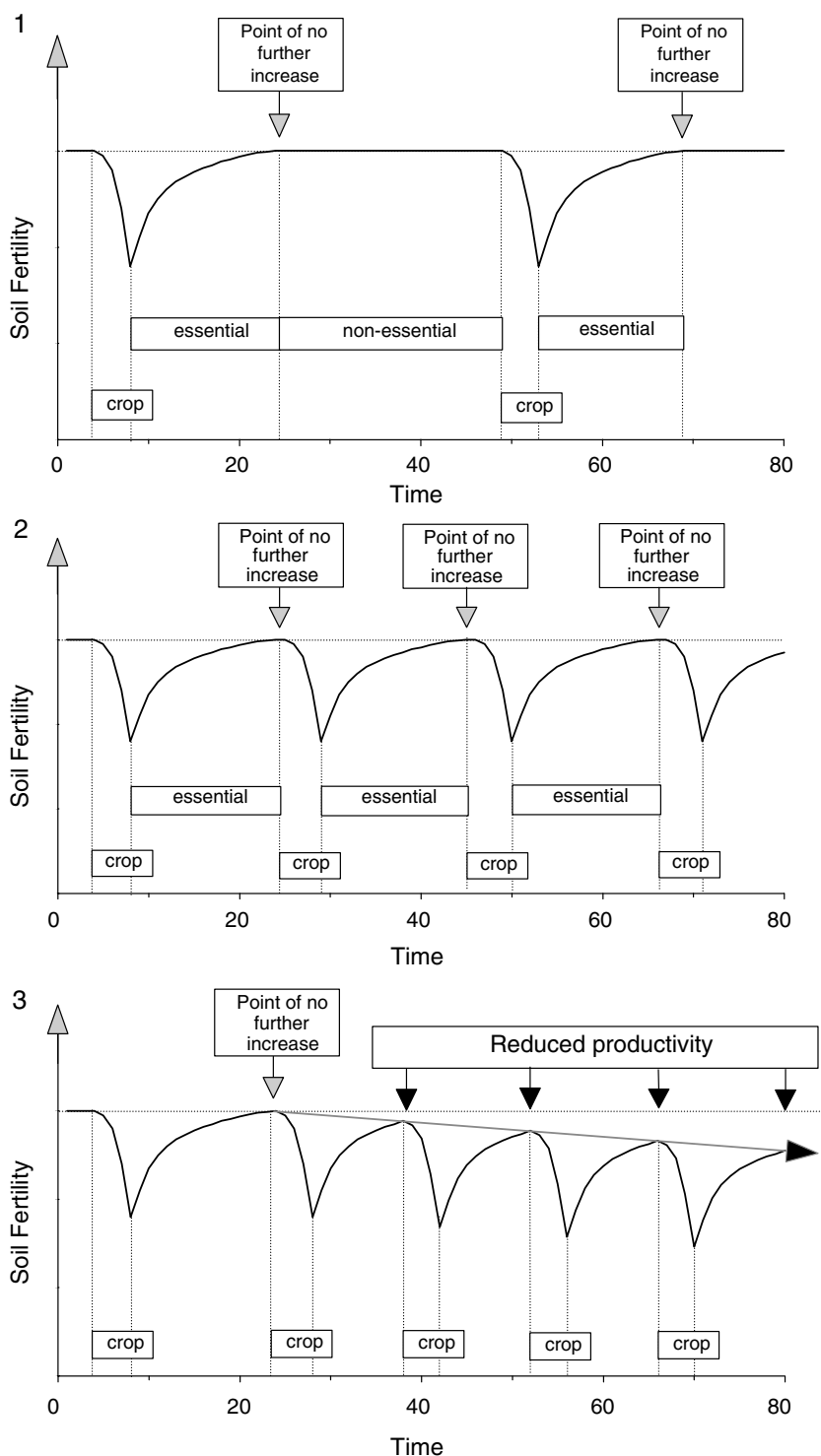

Figure 2. Hypothetical relationship between fallow length and soil fertility at different cropping frequencies. (1) cropping frequency low, permitting phases without additional fertility gains; (2) frequency exactly timed to match attainment of maximum fertility; (3) cropping frequency too high to attain maximum fertility.

land use at maximum land use frequency would require cropping when fertility has just been fully restored (Type 2 scenario, Figure 2). Higher land use frequency or shorter fallow periods than in the 'type 2' scenario, would hypothetically lead to reductions in crop yields due to incomplete fertility restoration (Type 3 scenario, Figure 2). While this general concept appears to be accepted, very few data are available that quantify soil fertility status as a function of fallow length. Empirical evidence shows that soil fertility or individual soil chemical, biological and physical properties are the better restored the longer the fallow. However, the exact pattern over time of this process is not known. Nolte and Hauser (submitted) found that fallow biomass production has a linear pattern. Nutrient accumulation in the biomass follows an asymptotic pattern as assumed in Guillemin's concept, if fallow lengths of up to 20 years are considered. However, when data from shorter fallows of up to 8 years from West and Central Africa were analysed, both, biomass production and nutrient accumulation in the fallow biomass followed progressive patterns, thus were inverse to the assumed concept, with low initial increments, increasing with time. Szott et al. (1999) compiled data on biomass vs. fallow length from the humid and sub-humid tropics; none of the functions was asymptotic. Soil C, N and P stocks did, with few exceptions, not change considerably within 10 years, none of the nutrients increased in an asymptotic pattern. Thus, the basic assumption of high initial increments of fertility recovery is probably incorrect.

For a smallholder farmer, soil fertility might be of secondary importance, yet crop yields are of paramount importance. However, there are very few data on the relationship between crop yield and fallow length. Even for relatively easily measurable factors such as biomass of, or nutrient accumulation in the fallow vegetation or soil chemical properties, correlations with subsequent crop yields are rarely available. The few data globally available led to the conclusion, that there is no general pattern of crop yield response to fallow age (Mertz 2002). However, the data available are largely from rather long fallow phases which may nowadays be of less importance, because the 'type 1' scenario (Figure 2) may no longer exist, for the largest proportion of the cropped land.

For farmers crop yields are of primary importance, while soil fertility is secondary, if it is a concern at all (Büttner and Hauser 2003). Full fertility recovery to maintain the land use systems as in the 'type 2' scenario (Figure 2) is largely out of the question due to insufficient time for recovery or in other terms shortage of land, leading to the risk of fertility decline as indicated in the 'type 3' scenario (Figure 2). Here is where planted fallows could play a mayor role, if they either recovered soil fertility faster or ensured higher crop yields than natural regrowth fallow.

If research is to provide useful solutions to farmers' problems, it has to deal with short fallow phases and use (increased) crop yields as a parameter of success. Dealing with short fallow phases is a matter of relevance. The importance of the early fallow phases is highlighted in Figure 3, because the attained level of recovery in situations of reduced fallow length, depends entirely on the shape of the recovery curve. Biological growth processes often follow sigmoid patterns with low initial increments (growth rates), increasing with time, reaching maximum growth rates in the point of inflexion, thereafter growth rates decrease towards zero. The few data on fallow recovery show progressive patterns and thus a scenario with the largest declines in recovery if the fallow phase is shortened.

The differences in recovery pattern would hypothetically lead to large differences in crop yield declines. Figure 4 shows the differences between systems with an asymptotic vs. a linear pattern. The system with a linear pattern would have a faster decline with shortened fallow length than in the original concept, and (not shown) systems with a progressive pattern would decline even faster.

Thus rather than determining the time required to attain complete fertility restoration we should investigate the early pattern of recovery to identify the most suitable fallow systems.

Results from planted tree-based fallows

Indigenous planted fallows

In West and Central Africa, there are few examples of farmers planting fallows. One such system was developed in south-eastern Nigeria

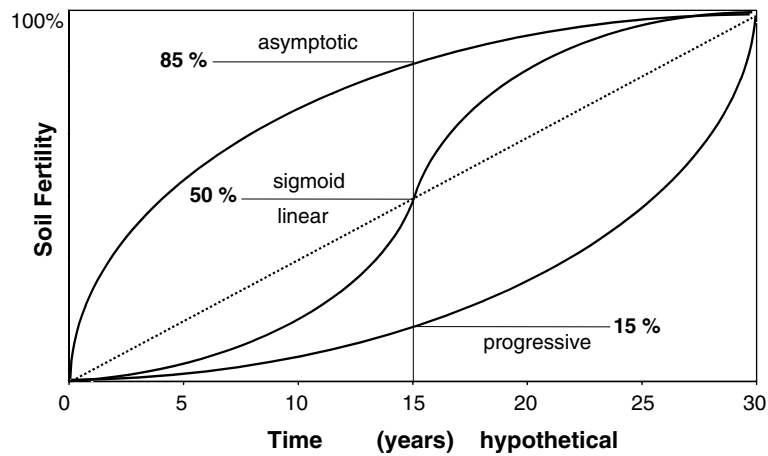

Figure 3. Hypothetical fertility recovery levels in case of a shortening of the fallow to half the length of the phase required, to reach 100% fertility (the point of no further increase in Figure 1), for four different patterns of the recovery.

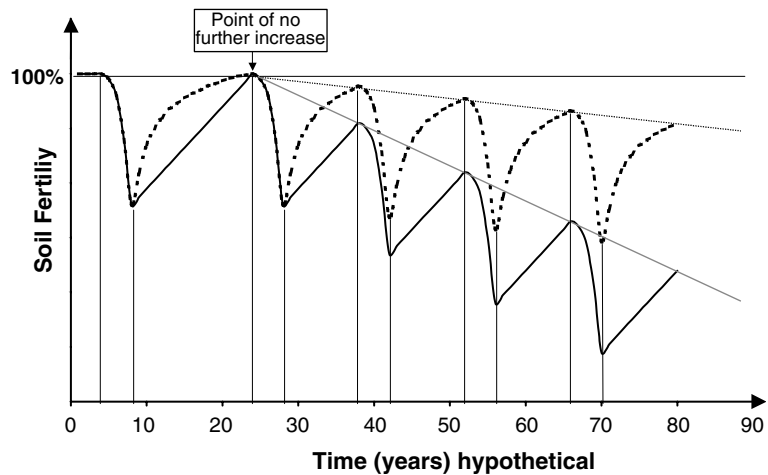

Figure 4. Hypothetical relationship between fallow length and soil fertility at the same cropping frequency but with different patterns of fertility replenishment, to demonstrate effects on long-term soil fertility. Broken line – asymptotic pattern (high increments at early fallow stages with decreasing increments); solid line linear increases throughout the fallow phase. In both systems the time required to reach the point of no further increase is the same.

where farmers established fallows of *Dactyldenia barteri* (Akobundu et al. 1993), a tree forming a dense canopy, profusely branching from the ground level and producing very recalcitrant leaves and a hard and resistant wood, suitable for staking yams (*Dioscorea* spp.). These fallows also contain other tree species, such as *Anthonatha macrophylla*, which are not planted but retained on purpose (Mulongoy et al. 1993). There is, however, no experimental evidence to show the effect of these planted and selected trees on crop yield. In Côte d’Ivoire, a system consisting of tree

strips (triple rows of trees) planted at various inter-strip distances has been used for a long time (Floret et al. 1993). Other planted tree fallows are woodlots of short duration. After wood harvest, short-term food crops are grown, followed by reforestation.

Introduced planted fallows

More recently, alley cropping or hedgerow inter-cropping systems were developed and introduced

to farmers (Kang et al. 1981). An alternative system, called block planting, in which the trees are not intercropped with food crops but grown in separate blocks, with the prunings cut and carried to food crop blocks was tested in Bénin (Böhringer and Leihner 1997).

Alley cropping was initially not designed to include distinguished phases of fallow for soil fertility restoration without crops being present. If land is used to grow non-food crop plants (such as trees), at times when food crops could be grown (usually the rainy seasons) we shall talk of real fallows. Many alley cropping systems were established for permanent cropping, in which trees grow during dry seasons, when crops are absent, or cannot grow at all. In such cases we will talk of pseudo fallows, because farmers do not lose a crop in favour of a real fallow.

Effects of planted fallow systems on crops

Crop yield response to tree fallows

A total of 630 comparisons were used from the literature of which 24.3% reported yield increases, 15.7% reported yield reductions, and a majority of 60% had no significant effect. In 590 cases data allowed to calculate yield responses. Figure 5 gives an overview of crop yield responses to tree-based fallows. With the exception of yam and groundnut a neutral response was observed most frequently. In sole maize, cassava intercropped with maize, cowpea and vegetables yield increases were found more often than yield decreases. In cassava, yam, plantain, groundnut and rice, yield decreases were more frequent than yield increases. The mean absolute and relative yield increase due to tree fallow was the highest in vegetables (Table 1), followed by maize and cowpea. The highest yield reductions were found in plantain and sole cassava, followed by yam and by cassava intercropped with maize. For maize intercropped with cassava, and groundnut practically no yield differences were observed between tree fallows and controls.

The smallest yield increments in the positive response category were attained with plantain and groundnut, while maize, yam, cowpea and vegetables showed yield increases of >50% in the positive response category. In the neutral response

category yam, cassava and cassava intercropped had overall negative yield increments, while plantain, yam, cassava and cassava intercropped with maize showed the highest yield reductions.

Across all crops, the weighted relative mean response to tree fallow (sum of (overall relative yield gain or reduction [%] * n)/ N) was +8.2%, where n is the number of comparisons for the crops and N is the total number of comparisons.

A separation on the basis of conditions under which experiments were conducted was unfortunately not possible, because too many publications lack some of the essential information. However, when the set of planted tree fallow experiments with sole maize was split in those conducted on-station researcher-managed and on Alfisols, vs. all the others, a striking 11.5 times larger maize yield increase was obtained in the former (Table 2). Unfortunately it is not possible to separate the soil effect from the management effect because the vast majority of experiments on Alfisols was on-station. However, this comparison casts doubt on the appropriateness of testing fallow management technologies on-station at all. Tian et al. (1995) have shown the tremendous difference in crop yields between farmer- and researcher-managed trials to show the potential for yield increases, but did not evaluate reasons for the gap.

Crop yield response to herbaceous fallows

Contrary to the situation in tree fallows, the herbaceous fallows had a dominantly positive yield response, with the exception of cassava and millet (Figure 6). Maize, sorghum, cotton and vegetables showed most often yield increases when either following or intercropped with herbaceous legumes. Although the data set is not as large as for tree fallows ($N = 396$) and there are new crops included (sorghum, millet, cotton), while others were not tested (plantain, yam, groundnut), it is obvious that the chance of success is higher when using herbaceous cover crops. Yield increases were attained in 52.5% of the comparisons, in only 3% of cases yield reductions were incurred and 44.5% of responses were neutral. In only two out of seven crops yield reductions were found, and only cassava had an overall negative response to herbaceous fallows (Table 3). Millet had only neutral responses and thus the lowest yield

Table 1. Mean crop yields of controls, mean absolute and relative yield difference to control by type of yield response and weighted overall mean yield gain or loss in planted tree fallow systems in West and Central Africa.

	Control		Yield response									Weighted mean response	
			Increase			Neutral			Decrease			Absolute	Relative
	Mg ha ⁻¹	<i>n</i>	Mg ha ⁻¹	%	<i>n</i>	Mg ha ⁻¹	%	<i>n</i>	Mg ha ⁻¹	%	<i>n</i>	Mg ha ⁻¹	%
Maize grain	1.946	332	1.223	62.8	101	0.059	3.0	219	-0.682	-35.0	37	0.335	17.2
Cassava roots	9.421	53	3.150	33.4	1	-0.736	-7.8	34	-6.374	-67.7	18	-2.577	-27.4
Maize intercropped	1.586	53	0.533	33.6	9	0.009	0.6	34	-0.563	-35.5	10	-0.010	-0.6
Cassava intercropped	5.047	47	2.154	42.7	8	-0.248	-4.9	33	-3.554	-70.4	6	-0.261	-5.2
Cowpea grains	0.538	39	0.297	55.2	13	0.030	5.6	20	-0.185	-34.4	6	0.086	16.0
Yam tubers	6.820	30	3.986	58.4	9	-0.691	-10.1	8	-3.602	-52.8	13	-0.555	-8.1
Vegetables	8.344	17	4.998	59.9	9	2.888	34.6	18			0	4.777	48.0
Plantain bunches	18.900	11	1.200	6.3	1	0.728	3.9	6	-16.700	-88.4	4	-5.585	-29.6
Groundnut grains	0.320	8	0.057	17.8	2	0.048	15.0	2	-0.072	-22.5	4	-0.010	-3.1

Sources: *Maize*; Kpomblekou-Ademawou (1986), Akonde et al. (1989, 1995), Koudokpon et al. (1995), Leihner et al. (1996), Tossah et al. (1999), Aihou et al. (1999), Böhringer and Leihner (1997); Schroth et al. (1995a), Siaw et al. (1991), Kang et al. (1981), Mulongoy and Van Der Meersch (1988), Kang and Duguma (1985), Akonde et al. (1996), Van der Meersch (1992), Kang et al. (1995), Iwuafor and Kumar (1995), Adeola and Ogunwale (1995), Kombiok et al. (1998), Cobbina (1998), Balle et al. (1998), Egbe et al. (1998), Aihou (1995), Lal (1991), Kühne (1993), Leihner et al. (1993), Kang et al. 1999. *Cassava*; Gichuru and Kang (1988), Böhringer and Leihner (1997), Akonde et al. (1995), Akonde et al. (1996), Meregini et al. (1995), Kühne (1993). *Maize and cassava intercropped*; Akonde et al. (1996), Hauser et al. (2000a), Hauser et al. (2000b), Hulugalle and Ndi (1993), Hulugalle and Ndi (1994), Chikoye et al. (2000), Kühne (1993), Nolte et al. (2005). *Cowpea*; Meregini et al. (1995), Siaw et al. (1991), Lal (1991), Kang et al. (1999). *Groundnut*; Schroth et al. (1995b), Nolte et al. (2005). *Yam*; Lal (1991), Oualou and Gnahoua (1998). *Plantain*; Banful et al. (2000), Yao (1998), Ruhigwa et al. (1995), Achard (1998). *Vegetables*; Palada et al. (1992), Chen et al. (1989).

Table 2. Mean maize grain yields of controls, mean absolute and relative yield difference to control by type of yield response and weighted overall mean yield gain or reduction of maize in on-station, researcher-managed experiments on Alfisols compared with all others in planted tree fallow systems in West and Central Africa.

	Control		Yield response									Weighted mean response	
			Increase			Neutral			Decrease			Absolute	Relative
	Mg ha ⁻¹	<i>n</i>	Mg ha ⁻¹	%	<i>n</i>	Mg ha ⁻¹	%	<i>n</i>	Mg ha ⁻¹	%	<i>n</i>	Mg ha ⁻¹	%
On-station, researcher.-managed, Alfisol	2.034	143	1.317	64.8	67	0.210	10.3	72	-0.908	-44.6	4	0.698	34.3
All others	1.880	189	0.350	18.6	34	-0.019	-1.0	124	-0.578	-30.8	31	0.060	3.2

increase (19.6%). All other crops attained overall mean yield increases of >30%, with up to 84% in vegetables.

Across all crops the weighted relative mean response to herbaceous legume fallow (sum of (overall relative yield gain or loss [%] * *n*)/*N*) was +36.7%, where *n* is the number of comparisons for the crops and *N* is the total number of comparisons.

Here, as for tree fallows, a separation on the basis of conditions under which experiments were conducted is not possible. However, leguminous

cover crop systems apparently were more extensively tested on-farm than tree fallow systems.

Effects of planted tree fallow systems on soil fertility

Trees as nutrient pumps: concept vs. evidence

The assumption that trees are acting as a nutrient pump has been a key concept in the development of systems such as alley cropping, and it remains a

Table 3. Mean yields of controls, mean absolute and relative yield difference to control by type of yield response and weighted overall mean yield gain or reduction in planted herbaceous legume fallow systems in West and Central Africa.

	Control		Yield response									Weighted mean response	
			Increase			Neutral			Decrease			Absolute	Relative
	Mg ha ⁻¹	n	Mg ha ⁻¹	%	n	Mg ha ⁻¹	%	n	Mg ha ⁻¹	%	n	Mg ha ⁻¹	%
Maize	1.528	264	0.931	60.9	150	0.155	10.2	106	-0.596	-39.0	8	0.573	37.5
Rice	0.655	92	0.487	74.69	37	0.138	21.1	45	0	0	0	0.264	40.3
Vegetables	0.478	3	0.627	131.3	8	0.042	8.9	5	0	0	0	0.402	84.2
Millet	0.864	12			0	0.169	19.6	12			0	0.169	19.6
Sorghum	0.713	9	0.396	55.5	5	0.007	0.9	4			0	0.223	31.2
Cassava	8.266	9	1.500	18.1	1	0.055	0.7	4	-2.995	-36.2	4	-1.140	-13.8
Cotton	1.521	7	0.564	37.1	7			0			0	0.564	37.1

Sources: *Maize*; Vanlauwe et al. (2000a, b), Aihou and Adomou (2000), Segda and Hien (2000), Asibuo and Osei-Bonsu (2000), Totongnon et al. (2000), Akakpo et al. (2000), Tian et al. (2000a, b), Youri (1998), Hauser et al. (2002), Hamadina et al. (1996), Naab and Alhassan (2001), Hauser and Nolte (2002), Carsky et al. (1999), Tian et al. (1999), Charpentier et al. (1999), Carsky et al. (1998), Versteeg and Koudokpon (1993), Chikoye et al. (2000), N'Goran and N'Guessan Kanga (2000). *Rice*; Becker and Johnson (1998), Becker et al. (1998), Dogbe (1998), Segda et al. (2000). *Vegetables*; Osei-Bonsu et al. (2000). *Millet*; Kouyate and Jou (1998). *Sorghum*; Tarawali et al. (1998), Kouyate and Jou (1998). *Cassava*; Tian et al. (1999). *Cotton*; Charpentier et al. (1999).

basic assumption for the success of all agroforestry systems (Young 1989). The basic principle is the recovery of nutrients displaced to (Kang et al. 1989), or available in layers below the maximum rooting depth of food crops (Huxley 1986). A further assumption is that nutrient uptake in the densely rooted topsoil is of minor importance for the trees, thus avoiding competition. The degree of competition is apparently a function of nutrient availability and thus the initial or inherent soil fertility vs. the nutrient demand of crops and trees. Akinnifesi et al. (1997) found no effects of the presence of *L. leucocephala* and root barriers on maize grain yield, concluding that there is no competition (for N in this experiment) between hedgerows and maize. There is a large amount of further information on crop/tree interactions, compiled in an excellent book by Ong and Huxley (1996).

The recovery of displaced nutrients from deeper layers and access to untapped subsoil nutrient resources is probably a process contributing to the success of tree based fallows and alley cropping, where subsoil nutrient resources exist. Although it is likely that more closed nutrient cycling in tree-based systems retains more nutrients in the upper soil layers that are rooted by crops, no evidence for net gains of nutrients through deep reaching tree roots could be found. Rowe et al. (1999) used stabilised ¹⁵N applied at 10, 30 and 50 cm depth

between hedgerows of *Peltophorum dasyrrhachis* and *G. sepium*. The groundnut crop took up a larger proportion of the recovered ¹⁵N than the trees from any of the amended layers. Mekonnen et al. (1997) showed that under both natural regrowth and *Sesbania sesban* fallow, less nitrate was found than under a maize crop in western Kenya. However, Mekonnen et al. (1999), reporting results from the same site, concluded that the quantification of downward nitrate movement and nitrate retrieval from the subsoil by trees is likely to be prone to large uncertainties. For other nutrients and most other locations in the humid tropics the importance of subsoil nutrient uptake by trees has yet to be proven (Sanchez 1995). Lehmann et al. (2001) found in the Brazilian Amazon, that rather than recovering nutrients from deeper soil layers, cycling of nutrients in the topsoil is the more efficient approach to retain soil fertility. Vanlauwe et al. (2002) determined root density distribution of *S. siamea* on derived-savanna soils in Togo, yet could not show the root safety net's function, due to processes and tree management practices which could cause nutrients to bypass the safety net.

Stahr et al. (1996) found in southern Bénin, that the water balance was only marginally affected by alley cropping with four different species and leaching rates were not different between no-tree

control and alley cropping systems. Leaching was identified as the most important cause of nutrient losses and negative K balances were calculated for all alley cropping species. Consequently they challenged the appropriateness of alley cropping. Deep rooting food crops had a higher water and nutrient use than alley cropping systems in their study. There are indications of deep-layer water withdrawal by *L. leucocephala* on high base status Alfisol at Ibadan (Grimme et al. 1983). On a southern Cameroonian ferric Acrisol, hedgerows of *L. leucocephala* and *G. sepium* withdrew more water during the dry season than a no-tree control, yet, did not significantly reduce the water resources below 60 cm depth compared to a natural regrowth fallow of the same age. (Hauser et al. 2005). In a second dry season, the grass-dominated natural fallow extracted more water in the top soil than the tree systems. Within the tree systems, some heterogeneity of water withdrawal was found yet not enough to cause differences in total water content of a 0–150 cm soil profile. On more fertile Alfisol at Ibadan, both water content (Hauser 1990) and nutrient distribution in the soil solution at different depths of the soil profile were affected by tree hedgerows: in the no-tree control and in the middle of the interrow space, nutrient concentrations increased with soil depth while under the hedgerows concentrations decreased with depth (Brussaard et al. 1993). Similar nutrient profiles were found on an Acrisol (terre de barre) in southern Bénin (Horst et al. 1995). They concluded, that reduced leaching in systems with *L. leucocephala* may improve soil fertility in the long-term. Contrary to Stahr et al. (1996), Kühne (1993) found *L. leucocephala* to be very efficient in water uptake in the interrow space. Seepage and nutrient loss was reduced under the hedgerow intercropping system. However, after 4 years of cropping with pruning application, no significant differences were found in soil chemical properties between alley cropped and no-tree control plots. Vanlauwe et al. (2001) observed very low recoveries of ^{15}N -labelled fertilizer by *S. siamea* from the subsoil on an Alfisol in south-western Nigeria. Schroth and Zech (1995b) found a higher fine root production in the alley than under hedgerows of *G. sepium* in Ivory Coast. Contrary to observations by Kühne (1993), Smucker et al. (1995) found very few *L. leucocephala* roots in the interrow space, under a second season cowpea crop on an Alfisol

in southwestern Nigeria, concluding that competition is weak. On a southern Cameroonian Oxisol, alternating hedgerows of *L. leucocephala* and *G. sepium*, withdrew 28 mm more water from a 1.5 m soil profile than a no-tree control early during the dry season (Hauser et al. 2005). The effect was restricted to one particular soil layer and short-lived. At the start of rains there were no differences in the water content between fallows. In a second year of measurements this pattern was confirmed, i.e., the natural, grass-dominated fallow was as efficient in water withdrawal as the tree systems. Lower soil water content at the start of rains could have contributed to delayed and less seepage, as more rain is required to saturate the soil profile.

Changes in soil chemical and biological properties under tree fallow

Table 4 gives an overview of changes in soil chemical properties due to tree fallows. Within each experiment changes in soil chemical properties per tree species and per any additional treatment such as fertiliser application or tree density (row distance) were counted. As the experiments were conducted over a different number of years, only the situation at the end of the experiment was considered.

The frequency distribution of changes is very similar to the distribution of crop yield responses, with less frequent negative effects and slightly more neutral and positive effects of tree fallow. Overall, it appears that tree fallows are not capable of bringing about major positive changes in soil quality.

Tree fallow may mimic a forest situation and thus provide good conditions for soil fauna. Table 5 shows that soil biological properties under tree fallow had a more favourable response, with improvements in 35% of the cases compared with 5% reporting deterioration.

Planted fallow for weed control and as weeds

Fallow phases act as a weed break (de Rouw 1995). The reduction in weed pressure depends on the previous weed flora, the length of the fallow phase and the viable live time of the weed seeds. In shortened fallows die-back of weed seeds may no longer play an important role. Further, with shortened fallows the landscape will be a mosaic of

Table 4. Frequency distribution of effects of tree fallow or alley cropping on soil chemical properties in experiments in West and Central Africa.

	Response of nutrient concentration or property			Total	Sources
	Positive	Neutral	Negative		
Organic C/organic matter	5	10	1	16	1, 2, 3, 5, 8, 9, 11, 16, 17, 18
Total N	8	7	0	15	2, 3, 5, 7, 8, 9, 10, 11, 12, 17
Exchangeable Ca	2	6	1	9	1, 6, 8, 10, 13, 16, 19
Exchangeable Mg	2	6	2	10	1, 6, 8, 10, 13, 19
Exchangeable K	3	6	2	11	1, 2, 6, 10, 15, 17, 19
Available P	1	6	2	9	2, 3, 5, 10, 11, 15, 18, 19
pH	0	5	0	5	3, 8, 11, 18
Cation exchange capacity	0	2	0	2	5, 8
Total	21	48	8	77	
Relative	27.3	62.3	10.4		

Sources: 1, Hauser and Kang (1993); 2, Yamoah et al. (1986); 3, Van Der Meersch (1992); 4, Siaw et al. (1991); 5, Mulongoy et al. (1993); 6, Hulugalle (1992); 7, Danso and Morgan (1993a, b); 8, Schroth et al. (1995a); 9, Yao (1998); 10, Aihou et al. (1999); 11, Leihner et al. (1993); 12, Kombiok et al. (1998); 13, Iwuafor and Kumar (1995); 14, Meregini et al. (1995); 15, Kanmenge et al. (1996); 16, Hulugalle and Ndi (1993); 17, Cobbina (1998); 18, Ambassa-Kiki and Babalola (2000); 19, Kang and Shannon (2001).

Table 5. Frequency distribution of effects of tree fallow or alley cropping on soil biological properties in experiments in West and Central Africa.

	Response of soil biological property			Total	Sources
	Positive	Neutral	Negative		
Earthworm density or biomass	2	4	0	6	1
Casting activity	10	18	1	29	2, 3, 4, 5, 6, 7
Arthropod density	2	2	1	5	8, 9, 10
Total	14	24	2	40	
Relative	35.0	60.0	5.0		

Sources: 1, Buresh and Tian (1998); 2, Hauser and Asawalam (1998); 3, Hauser et al. (1997); 4, Asawalam (1997); 5, Hauser (1993b); 6, Henrot and Brussaard (1997); 7, Kanmenge et al. (1996); 8, Tian et al. (1993); 9, Adejuyigbe et al. (1999); 10, Tian et al. (1998).

fallows and cropped land, from where weed seeds can invade, negating any reduction in the seed bank.

Certain tree species, flowering early and producing large numbers of seeds may as well turn into weeds, especially when particular areas of land are allocated to the trees, such as in alley cropping. *L. leucocephala*, (Akobundu et al. 1995; Chikoye et al. 2000) *S. spectabilis* and *F. macrophylla* (Hauser 2002) are examples of such species. The severity of planted trees developing into weeds increases with the length of the fallow phase. After two fallow phases of two years each, *F. macrophylla* had spread to all but one out of 12 plots and contributed up to 30% (mean 18.8%) of the interrow biomass in the no-tree control (Hauser, IITA, Humid Forest Eco-regional Center, Yaoundé, Cameroon, unpublished). In southern

Cameroon, *L. leucocephala* was abandoned because farmers could not control volunteer seedlings (Kanmenge and Degrande 2002). After multilocational testing of *Calliandra calothyrsus*, a species recommended for southern Cameroon (Duguma and Tonye 1994) it became obvious that the species was not improving crop yields (Nolte et al. 2005) and turned during the subsequent fallow phase into a difficult to be removed weed (Hauser, IITA, Humid Forest Eco-regional Center, Yaoundé, Cameroon, personal observation). The ability to suppress weeds is highly species dependent. In southern Cameroon, neither *Dactyloctenium aegyptium* nor *F. macrophylla* reduced volunteer regrowth in the interrow spaces during a 2 years fallow phase. *Senna spectabilis* caused a reduction to approximately 50% in regrowth

compared with a no-tree control (Hauser 2002). After one year of cropping and a further 2 years fallow phase, the volunteer regrowth reduction by *S. spectabilis* had dropped to 32% (Hauser, IITA, Humid Forest Eco-regional Center, Yaoundé, Cameroon, unpublished). In a comparison between natural fallow, *Leucaena leucocephala* and *Pueraria phaseoloides*, over 7 years, weed biomass was in all years the lowest in the *P. phaseoloides* system. The *L. leucocephala* system was not different from natural fallow in 2 years and had significantly more weed biomass than both other fallows in 1 year (Chikoye et al. 2000).

Preconditions for the adoption of tree fallows

In addition to bio-physical limitations such as amount and distribution of rainfall, Whittome et al. (1995) identified the following conditions as suitable for alley cropping: (1) maize is the dominant crop; (2) land scarcity, indicated by shortened fallows and declining soil fertility; (3) scarcity of fuelwood and staking material; and (4) individual land ownership is common. Sanchez (1995) concluded that alley cropping is likely to work if: (1) soils are fertile without major nutrient limitations; (2) rainfall is adequate during the cropping season; (3) land is sloping with erosion hazard; (4) there is ample supply of labour, coupled with a scarce supply of land; and (5) land

tenure is secure. In contrast, Adesina et al. (2000), investigating the adoption potential of alley farming in the Southwest Province of Cameroon, concluded that farmers in areas of high population density and high pressure on land are less likely to adopt alley farming. Versteeg and Koudokpon (1993) found a similar response of farmers in southern Bénin, where *Mucuna pruriens* cover crop fallow was preferred over alley farming in situations with extremely high pressure on land and severely degraded soils. Tree fallows and alley cropping are technologies that require long-term land security. If land tenure is not secure, any investment in future benefits is unlikely, due to the attached risk of losing the investment. In the Cameroonian highlands the cultural and customary regulations made it more difficult for women than for men to plant trees in their farms (Vabi et al. 1995). Lawry et al. (1995) found that with increasing security of land tenure the incentives to establish alley cropping increased, yet land scarcity, declining soil fertility and lack of fodder were essential to continue with the system.

Time constraints to adoption

In southern Bénin, Koudokpon et al. (1995) identified ‘the time it takes before results become visible to farmers’ as a major constraint to the adoption of alley cropping. In their demonstrations only few farmers tried alley cropping, the

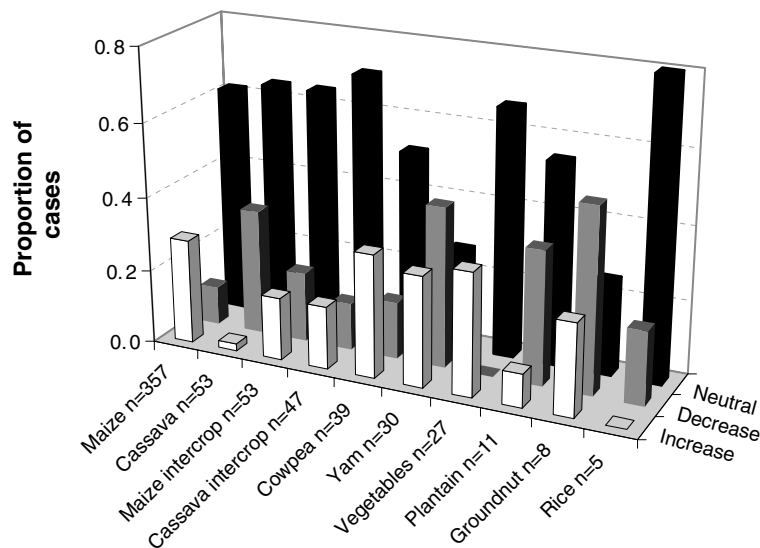

Figure 5. Relative distribution of crop yield responses to tree fallow systems in experiments in West and Central Africa.

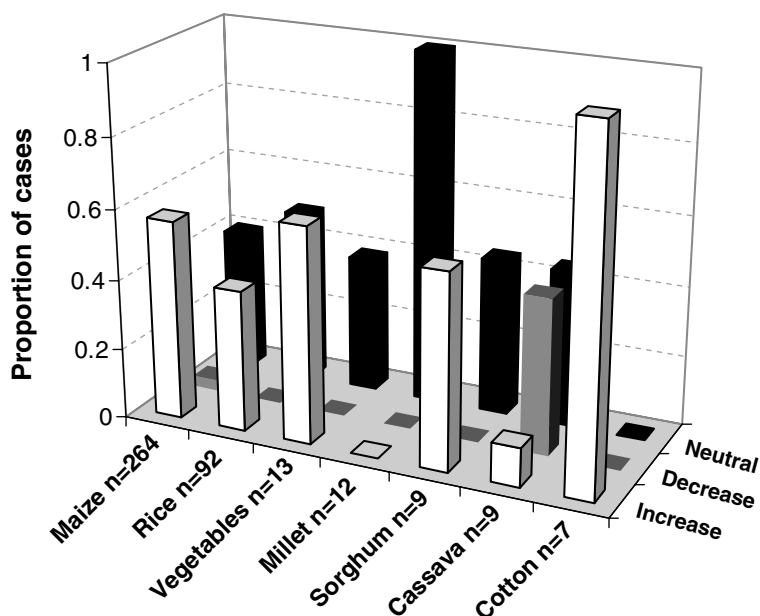

Figure 6. Relative distribution of crop yield responses to herbaceous fallow systems in experiments in West and Central Africa.

alternative planted fallow with the annual climbing herbaceous *M. pruriens* var. *utilis* was adopted by many more. Tian et al. (1995) showed that it took 4 years before alley cropping with *L. leucocephala* attained consistently higher yields than the no-tree control.

Labour constraints to adoption

A higher biomass production and a high proportion of wood in the biomass usually leads to a higher labour requirement for clearing and burning or the removal of the biomass in the tree-based fallows. Ngambeki (1985) reports a 50% higher labour requirement for managing *L. leucocephala* alley cropping system than natural regrowth. In southern Cameroon, the clearing after 2 years of fallow of *C. calothyrsus* required 66.8 and 73.9 h ha⁻¹ more than clearing of seeded *P. phaseoloides* fallow and natural regrowth dominated by *C. odorata*, respectively (Hauser, IITA, Humid Forest Eco-regional Center, Yaoundé, Cameroon, unpublished); burning the tree biomass required almost eight times more time. Not enough information is available on the economics of wood removal from fallows vs. the consequences on crop production to assess the suitability of cropping after wood export. However, Nolte et al. (2003) determined that 18% of N, 21% of P, 28%

of K, 16% of Ca and 14% of Mg taken up in *C. calothyrsus* fallow biomass would be lost, if wood was exported after 2 years of fallow. Tillage may be more difficult in tree fallows if shallow roots obstruct the implements from penetrating the soil. Similarly, the harvest of root and tuber crops and crops such as groundnut or bambara groundnut may be more labour-intensive if woody tree roots need to be cut in order to harvest pods and tubers unharmed. Farmers may not accept tree fallows if labour requirements for slashing, burning and pre-seeding land preparation are higher than in other fallow types without sufficiently high yield advantages through either fallow by-products or the planted food crops. Charcoal production from planted leguminous trees was shown in Côte d'Ivoire to be a major source of income in the vicinity of urban centres, while the crop response to these fallows was negligible (Balle et al. 1998). Farmers perceive the labour requirements for establishing tree-based fallows as too high or unnecessary, if reasonably old fallow land is still sufficiently available (Franzel 1999).

Improve tree-based fallows or invest in alternative systems?

Sanchez (1995) challenged the suitability of alley cropping on low fertility soils. The information in

Table 2 confirms his view and low adoption rates as well as doubts about the validity of past research results reinforce the challenge. This review expands the challenge of suitability to other tree-based fallow systems (Table 1).

Vandermeer (1998) interpreted an analysis of alley cropping results by Sanchez (1995) as a suggestion ‘that previous enthusiasm for alley cropping is unwarranted...’, and that the impression is given: ‘...that alley cropping simply will not work and perhaps should be abandoned...’. He correctly argued that all experiments were designed *ad hoc* without the required information on tree densities, planting patterns and their relationships to competition and facilitation. He presents a model illustrating how to balance competition and facilitation to maximise crop yields in alley cropping. However, the functions used in the model are all hypothetical and application of the model for a particular species and site requires determination of the increase in crop yield from facilitation through pruning application, the relationship between tree density and amount of prunings produced, and the reduction in crop yield through competition with trees. Here the question is warranted how much more effort can be justified in redesigning tree-based fallow systems or whether there is more justification to increase efforts to investigate alternative fallow types. The results compiled here indicate that herbaceous legumes and cover crops have more potential to perform in very short fallow systems. Yet, research on these systems is largely limited to the sub-humid zones although cover crops can be successfully used in the humid tropics (Hauser and Nolte 2002; Hauser et al. 2002).

Tree species screening may still need to be considered an important aspect to improve planted tree-based fallow systems. The majority of experiments in West Africa were conducted with a limited number of tree species, mainly *L. leucocephala*, *G. sepium*, and *S. siamea*. Other species were only tested in a few cases and fallow by-products of trees have been entirely ignored. *Inga edulis* and *Erythrina poeppigiana*, species reported as beneficial in South America (Staver 1989; Szott et al. 1991; Alegre et al. 2000) have either not been tested or are still in the screening phase in West Africa (Owino et al. 1995).

Trees’ ability to increase crop yields is insufficient, therefore they need to produce an appreciated or marketable product to generate additional benefit to balance or overcome problems associated with crop production. Alegre et al. (2000) showed for *Inga edulis*, producing fruit and fire wood, and *Colubrina glandulosa*, producing poles, that the inclusion of the revenue generated through fallow tree by-products increased cash flow and returns to labour over those of a natural fallow and a herbaceous legume fallow system. Thus, further research should explore the potential value of planted fallow by-products and focus on tree species providing additional benefits other than soil fertility improvement. Yonkeu and Enoh (1998) have demonstrated in Cameroon, that there is still reason to explore the native flora for species with multiple uses and consumable or marketable tree products. Promising examples of introduced species are timber production with *A. auriculiformis* in Southern Bénin and firewood and fruit production with *Inga edulis* in Southern Cameroon.

Conclusion

Planted fallows have considerable potential to contribute to soil fertility maintenance and increased food production. However, there is as well considerable doubt about their potential to improve farmers’ livelihoods due to uncertain crop yield responses, high labour requirements and a time lag between implementation and the expression of crop yield increases.

To answer the question which role planted fallows can play in the humid and sub-humid zone of West and Central Africa the tree- and the herbaceous legume-based fallows, have to be evaluated separately.

Planted herbaceous legume fallows can:

- increase crop yields in a majority of crops,
- maintain crop production at very short (< 1 year) fallow lengths,
- reduce weed infestation and competition with crops,
- reduce labour requirements in slash and burn and slash and mulch food crop systems.

Yet, they are unlikely to:

- increase farm revenue through valuable fallow by-products.

Planted tree fallows can

- improve or maintain soil chemical and biological properties,
- increase farm revenue through fallow by-products such as, timber, charcoal and fruit,
- increase crop yields in a limited number of crops under specific conditions.

Yet, they are unlikely to:

- reduce labour requirements for food production,
- maintain crop production at very short fallow lengths,
- reduce weed infestation and competition with crops.

The goal of planted fallows in West and Central Africa may need to be redefined. The role of planted fallows for soil fertility improvement or maintenance comes probably second or even third, whereas immediate benefits from the fallow and ‘quantum-leap’ yield increases, preferably along with reduced labour requirements come first to farmers’ minds. Such advantages will determine adoption.

However, attention to soil fertility may become more important, once crop production is further intensified and fallow biomass management and land preparation are mechanized.

Then we should look closely at planted fallows, but most likely at herbaceous species rather than trees.

References

- Achard R. 1998. Place du bananier dans les associations agroforestières. In: Duguma B. and Mallet B. (eds), Regional Symposium on Agroforestry Research and Development in the Humid Lowlands of West and Central Africa. Proceedings of a Symposium Held 4–7 December 1995, Yaoundé, Cameroon, pp.175–179.
- Adeola A.O. and Ogunwale A.B. 1995. The effect of leguminous hedgerows on the yield of maize planted on inclines in Ilesha, Nigeria. In: Kang B.T., Osiname O.A. and Larbi A. (eds), Alley Farming Research and Development. Alley Farming Network for Tropical Africa, Ibadan, Nigeria, pp. 345–347.
- Adesina A.A. and Chianu J. 2002. Farmers’ use and adoption of alley farming in Nigeria. In: Barret C.B., Place F. and Aboud A.A. (eds), Natural Resources Management in African Agriculture. Understanding and Improving current Practices. CABI Publishing, Wallingford, UK, pp. 51–64.
- Adesina A.A., Mbila D., Nkamleu G.B. and Endamana D. 2000. Econometric analysis of the determinants of adoption of alley farming by farmers in the forest zone of southwest Cameroon. *Agr. Ecosys. Environ.* 80: 255–265.
- Adejuyigbe C.O., Tian G. and Adeoye G.O. 1999. Soil microarthropod populations under natural and planted fallows in southwestern Nigeria. *Agroforest. Syst.* 47: 263–272.
- Aihou K. 1995. Alley farming trials on *terre de barre* soils in Southern Bénin Republic. In: Kang B.T., Osiname O.A. and Larbi A. (eds), Alley Farming Research and Development. Alley Farming Network for Tropical Africa, Ibadan, Nigeria, pp. 255–260.
- Aihou K. and Adomou M. 2000. Contribution du phosphore a l’amélioration de l’assimilation de l’azote par le maïs en rotation avec le *Mucuna* et le niébé. In: Carsky R.J., Eteka A.C., Keatinge J.H.D. and Manyong V.M. (eds), Cover crops for natural resource management in West Africa. International Institute of Tropical Agriculture, Ibadan, Nigeria, pp. 14–22.
- Aihou K., Sangina N., Vanlauwe B., Lyasse O., Diels J. and Merckx R. 1999. Alley cropping in the moist savanna of West-Africa: I. Restoration and maintenance of soil fertility on ‘terre de barre’ soils of Bénin Republic. *Agroforest. Syst.* 42: 213–227.
- Akakpo C., Amadji F. and Carsky R.J. 2000. Integration du *Mucuna* dans les systemes culturaux du sud Bénin. In: Carsky R.J., Eteka A.C., Keatinge J.H.D. and Manyong V.M. (eds), Cover crops for natural resource management in West Africa. International Institute of Tropical Agriculture, Ibadan, Nigeria, pp. 175–184.
- Akinnifesi F.K., Kang B.T., Sangina N. and Tijani-Eniola H. 1997. Nitrogen use efficiency and N-competition between *Leucaena* hedgerows and maize in alley cropping system. *Nutr. Cycl. Agroecosys.* 47: 71–80.
- Akobundu I.O., Ekeleme F. and Agyakwa C.W. 1995. Effect of alley farming on weed infestation and floral composition. In: Kang B.T., Osiname O.A. and Larbi A. (eds), Alley Farming Research and Development. Alley Farming Network for Tropical Africa, Ibadan, Nigeria, pp. 137–143.
- Akobundu I.O., Isichei A.O., Meregini A.O., Ekeleme F., Agyakwa C.W., Tucker E.S. and Mulongoy K. 1993. An analysis of vegetation as a resource in south-eastern Nigeria. In: Mulongoy K. and Merckx R. (eds), Soil Organic Matter Dynamics and Sustainability of Tropical Agriculture. John Wiley & Sons, Chichester, UK, pp. 345–350.
- Akonde T.P., Lame B. and Kummerer E. 1989. Adoption of alley cropping in the province of Atlantique, Bénin. In: Kang B.T. and Reynolds L. (eds), Alley Farming in the Humid and Subhumid Tropics, Ibadan, Nigeria, 1987. IDRC, Ottawa, Canada, pp. 141–142.
- Akonde T.P., Leihner D.E. and Kang B.T. 1995. Response of maize and cassava to potassium fertilization and alley cropping with *Leucaena leucocephala* and *Acacia auriculiformis*. In: Kang B.T., Osiname O.A. and Larbi A. (eds), Alley Farming Research and Development. Alley Farming Network for Tropical Africa, Ibadan, Nigeria, pp. 248–254.

- Akonde T.P., Leihner D.E. and Steinmüller N. 1996. Alley cropping on an Ultisol in subhumid Bénin. Part I: Long-term effect on maize, cassava and tree productivity. *Agroforest. Syst.* 34: 1–12.
- Alegre J.C., Rao M.R., Arevalo L.A., Guzman W. and Faminov M.D. 2000. Planted tree fallows for improving land productivity and reducing deforestation in the humid tropics of Peru. Transcript of a Poster Presented at the Annual ASA-Meeting, Minneapolis, 5–9. November 2000, Minneapolis, USA.
- Ambassa-Kiki R. and Babalola O. 2000. Jachères améliorées et restauration de la fertilité d'un sol ferrallitique du Cameroun central. In: Floret C. and Pontanier R. (eds), *La jachère en Afrique tropicale*. John Libbey, Eurotext, Paris, pp. 587–593.
- Asawalam D.O. 1997. Earthworm Activity and Nutrient Cycling in Agricultural Systems in a Humid Tropical Environment. Unpublished Ph.D. thesis, Department of Soil Science. Nsukka, University of Nigeria, 250 pp.
- Asibuo J.Y. and Osei-Bonsu P. 2000. Influence of leguminous crops and fertilizer N on maize in the forest-savanna transition zone of Ghana. In: Carsky R.J., Eteka A.C., Keatinge J.H.D. and Manyong V.M. (eds), *Cover Crops for Natural Resource Management in West Africa*. International Institute of Tropical Agriculture, Ibadan, Nigeria, pp. 40–46.
- Balle P., Gauthier L., Gnahoua G.M., Mallet B., Olivier R. and Peltier R. 1998. Peut-on concilier production de bois et régénération de la fertilité dans les jachères de zone Guinée? L'expérience d'Oume en basse Côte d'Ivoire. In: Duguma B. and Mallet B. (eds), *Regional Symposium on Agroforestry Research and Development in the Humid Lowlands of West and Central Africa*. Proceedings of a symposium held 4–7 December 1995, Yaoundé, Cameroon, pp. 181–201.
- Banful A., Dziertror A., Ofori I. and Hemeng O.B. 2000. Yield of plantain alley cropped with *Leucaena leucocephala* and *Flemingia macrophylla* in Kumasi, Ghana. *Agroforest Syst.* 49: 189–199.
- Becker M. and Johnson D.E. 1998. Legumes as dry season fallow in upland rice-based systems of West Africa. *Biol. Fertil. Soils* 27: 358–367.
- Becker M., Johnson D.E. and Segda Z.J. 1998. The role of legume fallows in intensified upland rice-based systems of West Africa. In: Carsky R.J., Eteka A.C., Keatinge J.H.D. and Manyong V.M. (eds), *Cover Crops for Natural Resource Management in West Africa*. International Institute of Tropical Agriculture, Ibadan, Nigeria, pp. 85–106.
- Beets W. 1990. Raising and Sustaining Productivity of Smallholder Farming Systems in the Tropics. AgBe Publishing, Alkmaar, The Netherlands.
- Böhringer A. and Leihner D.E. 1997. A comparison of alley cropping and block planting system in sub-humid Bénin. *Agroforest. Syst.* 35: 117–130.
- Brussaard L., Hauser S. and Tian G. 1993. Soil faunal activity in relation to the sustainability of agricultural systems in the humid tropics. In: Mulongoy K. and Merckx R. (eds), *Soil Organic Matter Dynamics and Sustainability of Tropical Agriculture*. John Wiley & Sons, Chichester, UK, pp. 241–256.
- Buresh R.J. and Tian G. 1998. Soil improvement by trees in sub-saharan Africa. *Agroforest. Syst.* 38: 51–76.
- Büttner U. and Hauser S. 2003. Farmers' nutrient management practices in indigenous cropping systems in southern Cameroon. *Agr. Ecosys. Environ.* 100: 103–110.
- Carsky R.J., Oyewole B. and Tian G. 1999. Integrated soil management for the savanna zone of W. Africa: legume rotation and fertilizer N. *Nutr. Cycl. Agroecosys.* 55: 95–105.
- Carsky R.J., Tarawali S.A., Becker M., Chikoye D., Tian G. and Sangina N. 1998. *Mucuna* – herbaceous cover legume with potential for multiple uses. International Institute of Tropical Agriculture, Ibadan, Nigeria.
- Charpentier H., Doumbia S., Coulibaly Z. and Zana O. 1999. Fixation de l'agriculture au nord et au centre de la Côte d'Ivoire: quel nouveaux systemes de culture? *Agr. Dévelop.* 21: 4–70.
- Chen Y.S., Kang B.T. and Caveness F.E. 1989. Alley cropping vegetable crops with *Leucaena* in southern Nigeria. *Hort-Science* 24: 839–840.
- Chikoye D., Akobundu I.O. and Ekeleme F. 2000. Long term effects of *Pueraria phaseoloides* and *Leucaena leucocephala* fallow on weed growth and composition, and on crop yield of cassava intercropped with maize. In: Floret C. and Pontanier R. (eds), *La jachère en Afrique tropicale*. John Libbey, Eurotext, Paris, France, pp. 603–610.
- Cobbina J. 1998. Soil fertility changes under *Albizia*, *Casuarina* and *Senna* woodlots in the humid zone of Ghana and their influence on succeeding crop. In: Duguma B. and Mallet B. (eds), *Regional Symposium on Agroforestry Research and Development in the Humid Lowlands of West and Central Africa*. Proceedings of a symposium held 4–7 December 1995, Yaoundé, Cameroon, pp. 203–207.
- Coe R. 1994. Through the looking glass: ten common problems in alley-cropping research. *Agroforest. Today* 6: 9–11.
- Danso A.A. and Morgan P. 1993a. Alley cropping maize (*Zea mays* var. Jeka) with cassia (*Cassia siamea*) in The Gambia: crop production and soil fertility. *Agroforest. Syst.* 21: 133–146.
- Danso A. A. and Morgan P. 1993b. Alley cropping rice (*Oryza sativa* var. Barafita) with cassia (*Cassia siamea*): soil fertility and crop production. *Agroforest. Syst.* 21: 147–158.
- De Rouw A. 1995. The fallow period as a weed-break in shifting cultivation (tropical wet forest). *Agr. Ecosys. Environ.* 54: 34–43.
- Dogbe W. 1998. Green-manure crops for sustainable agriculture in the inland valley of northern Ghana. In: Buckless D., Eteka A., Osiname O., Galiba M. and Galiano G. (eds), *Cover Crops in West Africa Contributing to Sustainable Agriculture*. International Development Research Centre, Ottawa, Canada, pp. 213–216.
- Duguma B. and Tonye J. 1994. Screening of multipurpose tree and shrub species for agroforestry in the humid lowlands of Cameroon. *Forest Ecol. Manag.* 64: 135–143.
- Dvorák K.A. 1991. Methods of on-farm, diagnostic research on adoption potential of alley cropping. *Agroforest. Syst.* 15: 167–181.
- Egbe E.A., Nwoboshi L.C., Ladipo D.O. and Swift M.J. 1998. Potential of *Milletia thonningii* (Schum and Thonn) and *Pterocarpus santalinoides* (L'Her) for alley cropping at two locations in humid lowlands of West Africa. In: Duguma B. and Mallet B. (eds), *Regional Symposium on Agroforestry Research and Development in the Humid Lowlands of West*

- and Central Africa. Proceedings of a Symposium held 4–7 December 1995, Yaoundé, Cameroon, pp. 217–229.
- Floret C., Roger P. and Georges S. 1993. La jachère en Afrique Tropical. UNESCO, Paris, 86pp.
- Franzel S. 1999. Socioeconomic factors affecting the adoption potential of improved tree fallows in Africa. *Agroforest. Syst.* 47: 305–321.
- Gichuru M.P. and Kang B.T. 1988. Potential woody species for alley cropping on acid soils. *Agroforestry Land-Use systems: Proceedings of a Special Session of the American Society of Agronomy, Annual Meeting, Anaheim, California, USA*, pp. 85–87.
- Gockowski J., Tonye J., Baker D., Legg C., Weise S., Ndoumbé M., Tiki-Manga T. and Fouaguégué A. 2004. Characterization and Diagnosis of Farming Systems in the Forest Margins Benchmark of Southern Cameroon. *Social Science Working Paper Series No. 1*, International Institute of Tropical Agriculture, Ibadan, Nigeria, 67 pp.
- Grimme H., Juo A.S.R. and Kang B.T. 1983. Nutrient and Water use Efficiency. Annual Report for 1983, International Institute of Tropical Agriculture, Ibadan, Nigeria, pp. 154–156.
- Guillemin R. 1956. Evolution de l'agriculture autochtone dans les savannes de l'Oubangui. Deuxième partie: L'agriculture Oubanguienne a ses origines. *L'Agronomie Tropicale* 11: 143–176.
- Hamadina M.K., Henrot J., Isirimah N.O. and Tariah N.M. 1996. Potential benefits of a leguminous cover crop and a slow decomposing mulch in fallow management on a degraded soil of the humid tropics. In: Neeteson J.J. and Henrot J. (eds), *The Role of Plant Residues in Soil Management for Food Production in the Humid Tropics*. DLO-AB, Haren, The Netherlands, pp. 81–96.
- Hauser S. 1990. Water and nutrient dynamics under alley cropping vs. monocropping in the humid-subhumid transition zone. 14th International Congress of Soil Science, Kyoto, Japan, Vol. 6, pp. 204–209.
- Hauser S. 1993a. Root distribution of *Dactyladenia* (*Acioa*) *barteri* and *Senna* (*Cassia*) *siamea* in alley cropping on Ultisol. I. Implication for field experimentation. *Agroforest. Syst.* 24: 111–121.
- Hauser S. 1993b. Distribution and activity of earthworms and contribution to nutrient recycling in alley cropping. *Biol. Fertil. Soils* 15: 16–20.
- Hauser S. 2002. Volunteer biomass production between multi-purpose tree hedgerows after two years of fallow in southern Cameroon. *Agroforest. Syst.* 55: 139–147.
- Hauser S. and Kang B.T. 1993. Nutrient dynamics, maize yield and soil organic matter in alley cropping with *Leucaena leucocephala*. In: Mulongoy K. and Merckx R. (eds), *Soil Organic Matter Dynamics and Sustainability of Tropical Agriculture*. John Wiley & Sons, Chichester, UK, pp. 215–222.
- Hauser S. and Gichuru M.P. 1994. Root distribution of *Dactyladenia* (*Acioa*) *barteri* and *Senna* (*Cassia*) *siamea* in alley cropping on Ultisol. II. Impact on water regime and consequences for experimental design. *Agroforest. Syst.* 26: 9–21.
- Hauser S. and Asawalam D.O. 1998. Effects of fallow system and cropping frequency upon quantity and composition of earthworm casts. *Z. Pflanzenernähr. Bodenk.* 161: 23–30.
- Hauser S. and Nolte C. 2002. Biomass production and N fixation of five *Mucuna pruriens* varieties and their effect on maize yields in the forest zone of Cameroon. *J. Plant Nutri. Soil Sci.* 165: 101–109.
- Hauser S., Ndi J.N. and Hulugalle N.R. 2000a. Yields of maize/cassava intercrops grown with hedgerows of three multipurpose trees on an acid Ultisol of Cameroon. *Agroforest. Syst.* 49: 111–122.
- Hauser S., Ndi J.N. and Hulugalle N.R. 2000b. Performance of a maize/cassava intercrop in tilled and no-till *Senna spectabilis* alley cropping on an Ultisol in southern Cameroon. *Agroforest. Syst.* 49: 177–188.
- Hauser S., Henrot J. and Hauser A. 2002. Maize yields in mulched and burned *Mucuna pruriens* var. *utilis* and *Pueraria phaseoloides* relay fallow systems in southern Cameroon. *Biol. Agr. Horticult.* 20: 243–256.
- Hauser S., Vanlauwe B., Asawalam D.O. and Norgrove L. 1997. Role of earthworms in traditional and improved low-input agricultural systems in West Africa. In: Brussaard L. and Ferrera-Cerrato R. (eds). *Soil Ecology in Sustainable Agricultural Systems*. *Adv. Agroecol.* 1: 113–136.
- Hauser S., Norgrove L., Duguma B. and Asaah E. 2005. Dry season soil water regime under rotational fallow with alternating *Leucaena leucocephala* and *Gliricidia sepium* hedgerows on a southern Cameroonian Ultisol. *Agroforest. Syst.* 64: 73–82.
- Henrot J. and Brussaard L. 1997. Abundance, casting activity, and cast quality of earthworms in an acid Ultisol under alley-cropping in the humid tropics. *Appl. Soil Ecol.* 6: 169–179.
- Horst W.J., Kühne R. and Kang B.T. 1995. Nutrient use in *Leucaena leucocephala* and *Cajanus cajan* in maize / cassava alley cropping on *terre de barre*, Bénin Republic. In: Kang B.T., Osiname O.A. and Larbi A. (eds), *Alley Farming Research and Development*. Alley Farming Network for Tropical Africa, Ibadan, Nigeria, pp. 122–136.
- Hulugalle N.R. 1992. Amelioration of a highly degraded tropical Alfisol by planting I. Changes in soil physical and chemical properties 1989–91. *Land Degrad. Rehabil.* 3: 141–152.
- Hulugalle N.R. and Ndi N.J. 1993. Effects of no-tillage and alley cropping on soil properties and crop yields in a Typic Kandiodult of southern Cameroon. *Agroforest. Syst.* 22: 207–220.
- Hulugalle N.R. and Ndi N.J. 1994. Changes in soil properties of a newly-cleared Ultisol due to establishment of hedgerow species in alley cropping systems. *J. Agr. Sci. Camb.* 122: 435–443.
- Huxley P.A. 1986. Hedgerow intercropping: some ecological and physiological issues. In: Kang B.T. and Reynolds L. (eds), *Alley Farming in the Humid and Subhumid Tropics*. Ibadan, Nigeria, 1987, Ottawa, Canada, pp. 208–219.
- Iwuafor E.N.O. and Kumar V. 1995. Alley cropping of maize and *L. leucocephala* in the Northern Guinea savanna of Nigeria. In: Kang B.T., Osiname O.A. and Larbi A. (eds), *Alley Farming Research and Development*. Alley Farming Network for Tropical Africa, Ibadan, Nigeria, pp. 304–310.
- Kang B.T. and Duguma B. 1985. Nitrogen management in alley cropping systems. In: Kang B.T. and van der Heide J. (eds), *Nitrogen Management in Farming Systems in the Humid and Subhumid Tropics*. Institute for Soil Fertility (IB) Haren,

- The Netherlands and International Institute of Tropical Agriculture (IITA), Ibadan, Nigeria, pp. 269–284.
- Kang B.T. and Shannon D.A. 2001. Agroforestry with focus on alley cropping. In: Sustaining Soil Fertility in West Africa. SSSA Special Publication no. 58 Soil Science Society of America, Inc./American Society of Agronomy, Inc., Madison, WI, USA, pp. 197–224.
- Kang B.T., Wilson G.F. and Sipkens L. 1981. Alley cropping maize (*Zea mays* L.) and *Leucaena* (*Leucaena leucocephala* Lam) in southern Nigeria. *Plant Soil* 63: 165–179.
- Kang B.T., Wilson G.F. and Lawson T.L. 1984. Alley Cropping. A Stable Alternative to Shifting Cultivation. International Institute of Tropical Agriculture, Ibadan, Nigeria.
- Kang B.T., Van Der Kruijs A.C.B.M. and Couper D.C. 1989. Alley cropping for food crop production in the humid and subhumid tropics. In: Kang B.T. and Reynolds L. (eds), *Alley farming in the humid and subhumid tropics*. Ibadan, Nigeria, 1987, IDRC, Ottawa, Canada, pp. 16–26.
- Kang B.T., Caveness F.E., Tian G. and Kolawole G.O. 1999. Longterm alley cropping with four hedgerow species on an Alfisol in southwestern Nigeria – effect on crop performance, soil chemical properties and nematode population. *Nutr. Cycl. Agroecosyst.* 54: 145–155.
- Kang B.T., Hauser S., Vanlauwe B., Sanginga N. and Atta-Krah A.N. 1995. Alley farming research on high base status soils. In: Kang B.T., Osiname O.A. and Larbi A. (eds), *Alley Farming Research and Development*. Alley Farming Network for Tropical Africa, Ibadan, Nigeria, pp. 25–39.
- Kanmenge J. and Degrande A. 2002. From alley cropping to rotational fallow: Farmers' involvement in the development of fallow management techniques in the humid forest zone of Cameroon. *Agroforest. Syst.* 54: 115–120.
- Kanmenge J., Duguma B., Henrot J. and Isirimah N.O. 1996. Potential of some indigenous plant species for enhancing soil fertility in short fallow systems of the humid tropics. In: Neeteson J.J. and Henrot J. (eds), *The Role of Plant Residues in Soil Management for Food Production in the Humid Tropics*. DLO-AB, Haren, The Netherlands, pp. 107–118.
- Kombiok J.M., Rudat H. and Frey E. 1998. Screening of exotic and local tree species for maize production and soil fertility maintenance in the Guinea savanna zone of Ghana. In: Duguma B. and Mallet B. (eds), *Regional Symposium on Agroforestry Research and Development in the Humid Lowlands of West and Central Africa*. Proceedings of a Symposium Held 4–7 December 1995, Yaoundé, Cameroon, pp. 249–253.
- Koudokpon V., Versteeg M., Adegbola P. and Budelman A. 1995. The adoption of hedgerow intercropping by farmers on the Adja Plateau, South Bénin Republic. In: Kang B.T., Osiname O.A. and Larbi A. (eds), *Alley Farming Research and Development*. Alley Farming Network for Tropical Africa, Ibadan, Nigeria, pp. 483–498.
- Kouyate Z. and Juo A.S.R. 1998. Effets des engrais verts et des rotations de cultures sur la production des sols au Mali. In: Buckless D., Eteka A., Osiname O., Galiba M. and Galiano G. (eds), *Cover Crops in West Africa Contributing to Sustainable Agriculture*. International Development Research Centre, Ottawa, Canada, pp. 171–178.
- Kpombekou-Ademawou K. 1986. Alley cropping maize with *Leucaena leucocephala* in southern Togo. In: Kang B.T. and Reynolds L. (eds), *Alley Farming in the Humid and Subhumid Tropics*. Ibadan, Nigeria, 1987, IDRC, Ottawa, Canada, pp. 139–140.
- Kühne R. 1993. Wasser- und Nährstoffhaushalt in Mais – Maniok – Anbausystemen mit und ohne Integration von Alleekulturen (Alley cropping) in Süd - Bénin. Universität Hohenheim, Germany.
- Lal R. 1991. Myths and scientific realities of agroforestry as a strategy for sustainable management for soils in the tropics. *Adv. Soil Sci.* 15: 91–137.
- Laudelout H. 1990. La jachère forestière sous les tropiques humides, Unité des Eaux et Forêts, Centre de Recherches Forestières de Chimay. Université Catholique de Louvain. Louvain-la-Neuve, Belgique.
- Lawry S., Stienbarger D. and Jabbar M.A. 1995. Land tenure and the adoption of alley farming in West Africa. In: Kang B.T., Osiname O.A. and Larbi A. (eds), *Alley Farming Research and Development*. Alley Farming Network for Tropical Africa, Ibadan, Nigeria, pp. 464–471.
- Lehmann J., Muraoka T. and Zech W. 2001. Root activity patterns in an Amazonian agroforest with fruit trees determined by ³²P, ³³P and ¹⁵N applications. *Agroforest. Syst.* 52: 185–197.
- Leihner D.E., Bernard M., Akonde P., Böhringer A., Ernst-Karle R. and Stahr K. 1993. Development of improved cropping systems for the West African savanna eco-systems. Report of Results (Interim Report 1991–1993) of the Special Research Programme 308 'Adapted Farming in West Africa', University of Hohenheim, Germany, pp. 237–278.
- Leihner D.E., Doppler W. and Bernard M. 1996. Agroecological on-farm evaluation of selected technologies to improve soil fertility in southern Bénin. Report of Results (Interim Report 1994–1996) of the Special Research Programme 308 'Adapted Farming in West Africa', University of Hohenheim, Germany, pp. 360–409.
- Liya S.M. 1994. Nitrogen Fixation and Release by Woody Legumes used for Alley Cropping. Unpublished Ph.D. Thesis, Faculty of Agriculture and Forestry, University of Ibadan, Nigeria.
- Mekonnen K., Buresh R.J. and Jama B. 1997. Root and inorganic nitrogen distributions in sesbania fallow, natural fallow and maize fields. *Plant Soil* 188: 319–327.
- Mekonnen K., Buresh R.J., Coe R. and Kipteling K.M. 1999. Root length and nitrate under *Sesbania sesban*: Vertical and horizontal distribution and variability. *Agroforest. Syst.* 42: 265–282.
- Meregini A.O., Okoro E.G. and Kang B.T. 1995. Alley cropping on an Ultisol in Southeastern Nigeria. In: Kang B.T., Osiname O.A. and Larbi A. (eds), *Alley Farming Research and Development*. Alley Farming Network for Tropical Africa, Ibadan, Nigeria, pp. 282–286.
- Mertz O. 2002. The relationship between length of fallow and crop yields in shifting cultivation: a rethinking. *Agroforest. Syst.* 55: 149–159.
- Mulongoy K. and Van Der Meersch M.K. 1988. Nitrogen contribution by leucaena (*Leucaena leucocephala*) prunings

- to maize in an alley cropping system. *Biol. Fertil. Soils* 6: 282–285.
- Mulongoy K., Kunda K.N. and Chiang C.N.K. 1993. Effect of alley cropping and fallowing on some soil fertility parameters in southern Nigeria. In: Mulongoy K. and Merckx R. (eds), *Soil Organic Matter Dynamics and Sustainability of Tropical Agriculture*. John Wiley & Sons, Chichester, UK, pp. 47–55.
- Naab J.B. and Alhassan A.T. 2001. Effect of crop rotation, fertilizer nitrogen and manure on soil properties and maize yield in northern Ghana. In: Badu-Apraku B., Fakorede M.A.B., Ouedrago M. and Carsky R.J. (eds), *Impact, Challenges and Prospects of Maize Research and Development in West and Central Africa*. WECAMAN, IITA, Ibadan, Nigeria, pp. 269–280.
- Ngambeki D.S. 1985. Economic evaluation of alley cropping *Leucaena* with maize-maize and maize-cowpea in southern Nigeria. *Agr. Sys.* 17: 243–258.
- N'Goran A. and N'Guessan Kanga A. 2000. Influence d'un précédent de légumineuse herbacée et d'une jachère courte de deux ans sur la productivité du maïs au nord de la Côte-d'Ivoire. In: Floret C. and Pontanier R. (eds), *La jachère en Afrique Tropicale*. John Libbey, Eurotext, Paris, France, pp. 616–621.
- Nolte C. and Hauser S. (submitted) Natural fallows in the humid zone of West and Central Africa: their biomass production, nutrient accumulation and nutrient budget.
- Nolte C., Tiki-Manga T., Badjel-Badjel S., Gockowski J., Hauser S. and Weise S.F. 2003. Effects of calliandra planting pattern on biomass production and nutrient accumulation in planted fallows of southern Cameroon. *Forest Ecol. Manag.* 179: 535–545.
- Nolte C., Tiki-Manga T., Badjel-Badjel S., Gockowski J. and Hauser S. 2005. Groundnut, maize and cassava yields in mixed-food crop fields after calliandra tree fallow in southern Cameroon. *Exp. Agr.* 41: 21–37.
- Nye P.H. and Greenland D.J. 1960. *The Soil Under Shifting Cultivation*. Commonwealth Agric. Bureaux, Harpenden, UK.
- Oikeh S.O. 1999. *IITA Resource and Crop Management Technologies – A Synopsis*. International Institute of Tropical Agriculture, Ibadan, Nigeria, 155pp.
- Ong C.K. 1996. A framework for quantifying the various effects of tree-crop interactions. In: Ong C.K. and Huxley P. (eds), *Tree-Crop Interactions. A Physiological Approach*. CAB International, Wallingford, UK, pp. 1–23.
- Ong C.K. and Huxley P. 1996. *Tree-Crop Interactions. A Physiological Approach*. CAB International, Wallingford, UK, pp. 386
- Osei-Bonsu P., Asibuo J.Y., Quansah C., Adam M.G. and Olympio A.S. 2000. Effect of fallow and method of land preparation on the yield of okra/tomato grown in the dry season. In: Carsky R.J., Eteka A.C., Keatinge J.H.D. and Manyong V.M. (eds), *Cover Crops for Natural Resource Management in West Africa*. International Institute of Tropical Agriculture, Ibadan, Nigeria, pp. 47–54.
- Oualou K. and Gnahoua G. 1998. La culture en bandes alternées, une technique d'aide à la stabilisation des systèmes traditionnels de cultures. In: Duguma B. and Mallet B. (eds), *Regional Symposium on Agroforestry Research and Development in the Humid Lowlands of West and Central Africa*. Proceedings of a Symposium Held 4–7 December 1995, Yaoundé, Cameroon, pp. 279–288.
- Owino F., Ladipo D.O. and Esegu F. 1995. Selection of multipurpose tree/shrub species for alley cropping. In: Kang B.T., Osiname O.A. and Larbi A. (eds), *Alley Farming Research and Development*. Alley Farming Network for Tropical Africa, Ibadan, Nigeria pp.155–161.
- Palada M.C., Kang B.T. and Claassen S.L. 1992. Effect of alley cropping with *Leucaena leucocephala* and fertiliser application on yield of vegetable crops. *Agroforest. Syst.* 19: 139–147.
- Rowe E.C., Hairiah K., Giller K.E., van Noordwijk M. and Cadisch G. 1999. Testing the safety-net role of hedgerow tree roots by ¹⁵N placement at different soil depths. *Agroforest. Syst.* 43: 81–93.
- Ruhigwa B.A., Gichuru M.P., Swennen R. and Tairah N.M. 1995. Plantain production in an alley cropping system on an Ultisol in Southeastern Nigeria. In: Kang B.T., Osiname O.A. and Larbi A. (eds), *Alley Farming Research and Development*. Alley Farming Network for Tropical Africa, Ibadan, Nigeria, pp. 268–277.
- Ruthenberg H. 1980. *Farming Systems in the Tropics*, 3rd ed. Oxford University Press, Oxford, UK.
- Sanchez P.A. 1976. *Properties and Management of Soils in the Tropics*. Wiley, New York, USA, pp. 618
- Sanchez P.A. 1995. Science in Agroforestry. *Agroforest. Syst.* 30: 5–55.
- Schroth G. and Zech W. 1995a. Root length dynamics in agroforestry with *Gliricidia sepium* as compared to sole cropping in the semi-deciduous zone of West Africa. *Plant Soil* 170: 297–306.
- Schroth G. and Zech W. 1995b. Above- and below-ground biomass dynamics in a sole cropping and an alley cropping system with *Gliricidia sepium* in the semi-deciduous rainforest zone of West Africa. *Agroforest. Syst.* 31: 181–198.
- Schroth G., Balle P. and Peltier R. 1995b. Alley cropping groundnut with *Gliricidia sepium* in Côte d'Ivoire: effects on yields, microclimate and crop diseases. *Agroforest. Syst.* 29: 147–163.
- Schroth G., Oliver R., Balle P., Gnahoua G.M., Kanchanakanti N., Leduc B., Mallet B., Peltier R. and Zech W. 1995a. Alley cropping with *Gliricidia sepium* on an high base status soil following forest clearing: effects on soil conditions, plant nutrition and crop yields. *Agroforest. Syst.* 32: 261–276.
- Segda Z. and Hien V. 2000. Integration des plantes de couverture dans les systèmes de culture pluviaux de l'Est et de l'Ouest du Burkina Faso. *Acquis de recherche et perspectives*. In: Carsky R.J., Eteka A.C., Keatinge J.H.D. and Manyong V.M. (eds), *Cover Crops for Natural Resource Management in West Africa*. International Institute of Tropical Agriculture, Ibadan, Nigeria, pp. 23–32.
- Segda Z., Hien V. and Becker M. 2000. *Mucuna cochinchinensis* dans les systèmes d'association et de rotation culturales (Burkina Faso). In: Floret C. and Pontanier R. (eds), *La jachère en Afrique Tropicale*. John Libbey, Eurotext, Paris, France, pp. 622–627.
- Siaw D.E.K.A., Kang B.T. and Okali D.U.U. 1991. Alley cropping with *Leucaena leucocephala* (Lam.) De Wit and *Acacia barteri* (Hook.f.) Engl. *Agroforest. Syst.* 14: 219–231.

- Smucker A.J.M., Ellis B.G. and Kang B.T. 1995. Alley cropping on an Alfisol in the forest savanna transition zone: Root, nutrient and water dynamics. In: Kang B.T., Osiname O.A. and Larbi A. (eds), *Alley Farming Research and Development*. Alley Farming Network for Tropical Africa, Ibadan, Nigeria, pp. 103–121.
- Stahr K., Leihner D.E. and Huwer G. 1996. The influence of organic matter on agroforestry systems at different sites in southern Bénin. Report of Results (Interim Report 1994–1996) of the Special Research Programme 308 'Adapted Farming in West Africa', University of Hohenheim, Germany, pp. 187–218.
- Staver C. 1989. Shortened bush fallow rotations with relay-cropped *Inga edulis* and *Desmodium ovalifolium* in wet central Amazonian Peru. *Agroforest. Syst.* 8: 173–196.
- Szott L.T., Palm C.A. and Sanchez P.A. 1991. Agroforestry in acid soils of the humid tropics. *Adv. Agron.* 45: 275–301.
- Szott L.T., Palm C.A. and Buresh R.J. 1999. Ecosystem fertility and fallow function in the humid and subhumid tropics. *Agroforest. Syst.* 47: 163–196.
- Tarawali G., Dembelé E., N'Guessan B. and Youri A. 1998. Smallholders' use of stylosanthes for sustainable food production. In: Buckless D., Eteka A., Osiname O., Galiba M. and Galiano G. (eds), *Cover Crops in West Africa Contributing to Sustainable Agriculture*. International Development Research Centre, Ottawa, Canada, pp. 107–170.
- Tian G., Brussaard L. and Kang B.T. 1993. Biological effects of plant residues with contrasting chemical compositions under humid tropical conditions: effects on soil fauna. *Soil Biol. Biochem.* 25: 731–737.
- Tian G., Kang B.T., Akobundu I.O. and Manyong V.M. 1995. Food production in the moist savanna of West and Central Africa. In: Kang B.T., Akobundu I.O., Manyong V.M., Carsky R.J., Sanginga N. and Kueneman E.A. (eds), *Moist Savannas of Africa: Potentials and Constraints to Crop Production*. International Institute of Tropical Agriculture Ibadan, Nigeria, pp. 107–127.
- Tian G., Adejuyigbe C.O., Adeoye G.O. and Kang B.T. 1998. Role of soil microarthropods in leaf decomposition and N release under various land-use practices in the humid tropics. *Pedobiologia* 42: 33–42.
- Tian G., Kolawole G.O., Salako F.K. and Kang B.T. 1999. An improved cover crop – fallow system for sustainable management of low activity clay soils of the tropics. *Soil Sci.* 164: 671–682.
- Tian G., Kolawole G.O., Kang B.T. and Kirchhof G. 2000a. Nitrogen fertilizer replacement indexes of legume cover crops in the derived savanna of West Africa. *Plant Soil* 224: 287–296.
- Tian G., Kolawole G.O., Ishida F. and Carsky R.J. 2000b. On-farm study of *Pueraria* cover-crop fallow system in the derived savanna of West Africa. In: Carsky R.J., Eteka A.C., Keatinge J.H.D. and Manyong V.M. (eds), *Cover Crops for Natural Resource Management in West Africa*. International Institute of Tropical Agriculture, Ibadan, Nigeria, pp. 185–193.
- Tossah B.K., Zamba D.K., Vanlauwe B., Sanginga N., Lyasse O., Diels J. and Merckx R. 1999. Alley cropping in the moist savanna of West-Africa: II. Impact on soil productivity in a North-to-South transect in Togo. *Agroforest. Syst.* 42: 229–244.
- Totongnon J.K., Lame B. and Zannou P. 2000. Quelques performances et contraintes d'adoption du pois d'Angole (*Cajanus cajan*) et du pois macate (*Mucuna pruriens* var. *utilis*) en milieu paysan dans le Département de l'Atlantique, République du Bénin. In: Carsky R.J., Eteka A.C., Keatinge J.H.D. and Manyong V.M. (eds), *Cover Crops for Natural Resource Management in West Africa*. International Institute of Tropical Agriculture, Ibadan, Nigeria, pp. 109–119.
- Vabi M.B., Yamoah C. and Tambi E. 1995. On-farm trials with *Calliandra* in the Highland region of Northwestern Cameroon. In: Kang B.T., Osiname O.A. and Larbi A. (eds), *Alley Farming Research and Development*. Alley Farming Network for Tropical Africa, Ibadan, Nigeria, pp. 449–454.
- Vandermeer J. 1998. Maximizing crop yields in alley crops. *Agroforest. Syst.* 40: 199–206.
- Van Der Meersch M.-K. 1992. Soil Fertility Aspects of Alley Cropping Systems in Relation to Sustainable Agriculture, Ph.D. thesis, Katholieke Universiteit te Leuven, Leuven, Belgium.
- Vanlauwe B., Diels J., Sanginga N., Carsky R.J., Deckers J. and Merckx R. 2000a. Utilization of rock phosphate by crops on a representative toposequence in the Northern Guinea savanna zone of Nigeria: response by maize to previous herbaceous legume cropping and rock phosphate treatments. *Soil Biol. Biochem.* 32: 2079–2090.
- Vanlauwe B., Aihou K., Iwuafor E.N.O., Houngnandan P., Diels J., Manyong V.M. and Sanginga N. 2000b. Recent developments in soil fertility management of maize-based systems: the role of legumes in N and P nutrition of maize in the moist savanna zone of West Africa. In: Carsky R.J., Eteka A.C., Keatinge J.H.D. and Manyong V.M. (eds), *Cover Crops for Natural Resource Management in West Africa*. International Institute of Tropical Agriculture, Ibadan, Nigeria, pp. 3–13.
- Vanlauwe B., Sanginga N. and Merckx R. 2001. Alley cropping with *Senna siamea* in south-western Nigeria: I. Recovery of ¹⁵N labelled urea by the alley cropping system. *Plant Soil* 231: 187–199.
- Vanlauwe B., Akinnifesi F.K., Tossah B.K., Lyasse O., Sanginga N. and Merckx R. 2002. Root distribution of *Senna siamea* grown on a series of derived-savanna-zone soils in Togo, West Africa. *Agroforest. Syst.* 54: 1–12.
- Versteeg M.N. and Koudokpon V. 1993. Participative farmer testing on four low external input technologies, to address soil fertility decline in Mono province (Bénin). *Agr. Sys.* 42: 265–276.
- Whittome M.P.B., Spencer D.S.C. and Bayliss-Smith T. 1995. IITA and ILCA on-farm alley farming research: lessons for extension workers. In: Kang B.T., Osiname O.A. and Larbi A. (eds), *Alley Farming Research and Development*. Alley Farming Network for Tropical Africa, Ibadan, Nigeria, pp. 423–435.
- Yamoah C.F., Agboola A.A., Wilson G.F. and Mulongoy K. 1986. Soil properties as affected by the use of leguminous shrubs for alley cropping with maize. *Agr. Ecosys. Environ.* 18: 167–177.
- Yao N.T. 1998. Effet de deux sources d'azote (engrais minéraux et organiques) sur la productivité du bananier plantain. In: Duguma B. and Mallet B. (eds), *Regional symposium on agroforestry research and development in the humid lowlands of West and Central Africa*. Proceedings of a Sympos-

- sium held 4–7, December 1995, Yaoundé, Cameroon, pp. 305–320.
- Yonkeu S. and Enoh M.B. 1998. Quelques ligneux naturels a usages multiples de l'Adamaoua Camerounais: Écologie et utilisation potentielle. In: Duguma B. and Mallet B. (eds), Regional symposium on agroforestry research and development in the humid lowlands of West and Central Africa. Proceedings of a Symposium held 4–7 December 1995, Yaoundé, Cameroon, pp. 159–164.
- Young A. 1989. Agroforestry for Soil Conservation. Wallingford, CAB International.
- Youri A. 1998. Système de cultures avec légumineuses au Cameroun. In: Buckless D., Eteka A., Osiname O., Galiba M. and Galiano G. (eds), Cover Crops in West Africa Contributing to Sustainable Agriculture. International Development Research Centre, Ottawa, Canada, pp. 225–228.

Balanced Nutrient Management System Technologies In The Northern Guinea Savanna Of Nigeria: Validation And Perspective

Kolawole G.O.^{1*}, Diels J.¹, Manyong V.M.¹, Ugbabe O.², Wallays K.⁵, Dercon G.¹, Iwuafor E.N.O.², Falaki A.M.², Merckx R.³, Deckers J.⁴, Tollens E.⁵, Vanlauwe B.⁶ and Sanginga N.⁶

¹International Institute of Tropical Agriculture (IITA), Ibadan, Nigeria, c/o L.W. Lambourn & Co., Carolyn House, 26 Dingwall Road, Croydon CR9 3EE, England; ²Institute for Agricultural Research, Ahmadu Bello University, PMB 1044, Zaria, Nigeria; ³Laboratory of Soil and Water Management, Katholieke Universiteit, Leuven, Kasteelpark Arenberg 20, 3001 Heverlee, Belgium; ⁴Laboratory of Soil and Water Management, Katholieke Universiteit, Leuven, Vital Decosterstraat 102, 3000 Leuven, Belgium; ⁵Centre for Agricultural and Food Economics, Katholieke Universiteit, Leuven, de Croylaan 42, 3001 Heverlee, Belgium; ⁶Tropical Soil Biology and Fertility Institute of CIAT, ICRAF campus, United Nations Avenue, P.O. Box 30677, Nairobi, Kenya; *Corresponding author: Email: oladejokolawole@hotmail.com, Present address: Department of Agronomy, Ladoko Akintola University of Technology, PMB 4000, Ogbomoso, Oyo State, Nigeria.

Abstract

Based on experimental evidence that combining mineral fertilizers with organic matter may address poor soil fertility status and result in added benefits, farmer-managed demonstration trials were initiated in 9 villages in the northern Guinea savanna (NGS) of northern Nigeria. The trials had four treatments: (i) a farmers control in which the farmer grows maize according to his usual practice, (ii) the maize technology being promoted by the NGO Sasakawa-Global2000 (SG2000), involving hybrid seeds, proper plant density and fertilizer application practice, and fertilizer application rates that are relatively high for the region (136 kg N, 20 kg P, and 37 kg K ha⁻¹), (iii) the Balanced Nutrient Management Systems (BNMS) manure technology that follows the SG2000 package for maize, except that part of the fertilizer quantity is replaced by animal manure; and (iv) a soybean-maize rotation, again with reduced fertilizer rate to the maize.

Results from the full 2-year cycle indicated that the improved systems out-yielded the farmers' control treatment by about 1000 kg ha⁻¹. Maize after soybean gave yields similar to those obtained with the combined application of fertilizer and manure (BNMS-manure) to maize but slightly higher than the fertilizer-only practice (SG2000). There was large variability in the quantities of manure and fertilizers applied and maize yields obtained among farmers. Over the 2-year cycle, the improved soybean/maize rotation system was economically superior and dominated all the other systems because of its lowest variable costs and highest gross margins. At the end of the season, using an overall satisfaction score based on eight criteria, 94% of the farmers were satisfied with the soybean-maize rotation, 83% with the BNMS-manure treatment, and 29% with the SG2000 treatment. Farmers indicated manure availability as the main constraint for the BNMS-manure system; therefore, further research should focus on closed systems with crop-livestock integration in order to increase the manure availability within the farm. As many farmers were enthusiastic about the soybean-maize rotation treatment, SG2000 in partnership with the Agricultural Development Projects (ADPs) have started promoting this system alongside the SG2000 maize package to farmers in northern Nigeria

Key words: Balanced nutrients management systems, soybean/maize rotation, manure, Nigeria

Introduction

One of the most serious constraints to West Africa's agriculture is declining soil fertility. The reduction of traditional fallow periods has led to widespread depletion of soil nutrients and organic matter in the region. Crop yields are low and, in many areas, are decreasing. The long-term sustainability of major farming systems is therefore at risk (Smaling et al., 1997).

It has been recognized that the combined application of organic matter (OM) and fertilizer is required to increase crop production and arrest soil nutrient depletion in West Africa (FAO, 1999; Giller, 2002; Iwuafor et al., 2002). Organic inputs are needed to maintain the physical and physico-chemical health of the often shallow, sandy to sandy loam top soils while fertilizers are needed to supply a sufficient amount of nutrients to the crop. The impacts of inorganic N, organic N, and the combination of both on crop yield in West African moist savanna have been reported (Pieri, 1992; Vanlauwe et al., 2001a). Most of the trials reported above considered manure and crop residues as sources of organic inputs. However, livestock populations in the moist savanna are generally low, therefore, the applicability of animal manure for crop production is limited (Fernandez-Rivera et al., 1993). Also, crop residues are often removed from the field and used for purposes other than soil fertility maintenance, especially in the northern Guinea savanna (Manyong et al., 2001). Alternative sources of organic inputs produced in situ such as legume biomass in legume-cereal rotations, could be considered for use in cropping systems in the moist savanna zone.

Results of on-station and researcher-managed on-farm trials have shown that maize yields in a treatment that received a mixture of organic N and urea were similar to a treatment that received the full rate of N as urea and significantly higher than in a treatment that received only organic N (Vanlauwe et al., 2001b). Moreover, added benefits in terms of extra maize grain yield were observed on 2 of the 4 sites due to positive interactions between the mineral and organic inputs, likely related to better soil moisture conditions in the treatments with organic inputs. This indicates that farmers using the combination treatment would need to purchase only half of the quantity of fertilizer to obtain yields similar to those obtained from using urea alone. Therefore, results on the mixtures of organic and mineral fertilizer provided new opportunities and encouraged the testing of this technology in farmer-managed mode. For many years,

Sasakawa-Global2000 (SG2000) in collaboration with the State Agricultural Development Projects (ADPs) in northern Nigeria, has been promoting a maize package to farmers consisting of the use of hybrid seeds, proper plant density and fertilizer application practice, and the use of fertilizer rates that are quite high for the region (136 kg N, 20 kg P, and 37 kg K ha⁻¹). SG2000, the Institute for Agricultural Research (IAR), Zaria, and the International Institute of Tropical Agriculture (IITA) agreed to compare this package with a practice in which part of the fertilizer quantity is replaced by animal manure.

In addition, a maize-soybean rotation was also included, again with reduced fertilizer rate to the maize. The dual-purpose soybean produces fodder and grain, fixes atmospheric nitrogen, which may benefit the crop following it in rotation. The grain is also a cash product. The objectives of this trial were to (i) demonstrate the three packages for maize-based systems to farmers and extension workers (ii) recommend the most economically profitable management practice (iii) assess adoption/adaptation of the three packages for maize-based systems and (iv) solicit the opinion of farmers and extension workers at field days.

Materials and method

Study area

The trial was conducted in nine villages (Danayamaka, Fatika, Kaya, Galadimawa, Krosha, Kayarda, Kadiri Garo, Kufana and Buruku), located within three extension zones (Maigana, Lere, and Birnin Gwari) of Kaduna state. All villages are situated within the northern Guinea savanna (NGS), an ecoregion that covers an area of about 34 million ha in West and Central Africa; it is characterized by a length of growing period between 151 and 180 days (Jagtap, 1995).

Temperatures during the rainy period in the study area are 27.3–34.0°C (maximum) and 18.6–21.6°C (minimum). The growing period is between May and October. The mean annual rainfall is between 1200 and 1700 mm and the monthly distribution pattern is similar over the area (Wall, 1979). Soils in the area are predominantly developed in Quaternary aeolian deposits that covered and often mixed with material weathered from Basement Complex rocks (Bennett, 1980; McTainsh, 1984). A typical toposequence consists of shallow and/or gravelly soils (Plinthosols or soils with a petroferic phase) on the interfluvial crests, deeper Luvisols

and Lixisols on the valley slopes, and hydromorphic soils near the valley bottom (Delauré, 1998).

Trial design

Farmer-managed demonstration trials were initiated in 2000 in northern Nigeria in collaboration with IAR and SG2000. In 2002, 26 farmers in 9 villages in the NGS of Kaduna State established demonstration trials. For 2002, we present the results from 26 fields that participated in the farmer-managed demonstration trials. For 2003, we present the 2nd-year yields obtained by 20 farmers who completed the 2-year cycle of the trials. The demonstration trial compared 3 improved systems (SG2000 fertilizer-only package (136 kg N, 20 kg P, and 37 kg K ha⁻¹); BNMS-manure technology combining OM and fertilizer; soybean/maize rotation with reduced fertilizer application to maize) with a farmers' control treatment (Table 1).

The experimental layout consisted of a randomized complete block design with the farmers fields as replicates (blocks), and the same 4 treatments allocated at random to four 1250 m²-plots delineated in each farmer's field. Farmers were free to choose the maize variety for their field, but it was agreed that it had to be a hybrid, and that the same variety had to be planted in all 4 plots of their field. For the first year of the trial, all farmers received seed of the late-maturing soybean variety TGx 1448-2E to plant in the soybean/maize rotation treatment. Fields were ridged following farmers' practice. The manure (6 t DM ha⁻¹) was broadcast in the BNMS-manure treatment prior to ridging at the start of the season. In the 3 improved systems, planting density and fertilizer application followed the practice

recommended by SG2000/ADPs: 53,000 plants /ha; basal fertilizer application with NPK after crop emergence; top-dressing with urea when the plants are knee-high. Farmers were asked to buy and pay for the fertilizer themselves, as is the common practice in SG2000-ADP demonstration trials. Farmers were later asked which quantity and type of fertilizer they had actually applied on the 4 plots of their demonstration field. Additional data collected included labour (time spent by family members and cost for hired labour), market prices (for inputs and outputs), quantity of inputs used and grain yield. Farmer perception was assessed through open-ended questions posed at the middle of the season and at the end of the 2003 cropping season. The participating farmers were asked to assess each improved technology against 8 criteria on a 5-point scale as follows: (0) completely disagree, (1) disagree, (2) indifferent, (3) agree, and (4) completely agree. A satisfactory score on a particular criterion was considered if the rating was greater or equal to 3. A score greater than 50% of the total mark attainable (32 points) corresponded to an overall positive appreciation of the technology.

The grain yields were analyzed with a mixed model ANOVA using SAS (1999). Stability analysis (Guertal et al., 1994; Raun et al., 1993) was used to examine the stability of the treatments across environments. Yields for each plot were regressed linearly against site mean yield, i.e., the average of all treatments in a given field. A mixed model ANOVA was used to test the hypothesis of equality of slopes, using a model similar to one proposed for stability analysis by Stroup et al. (1993). Contrast statements in the ANOVA were used for pair wise comparison of slopes. Partial budget analysis was applied to analyze the economic returns of each system.

Table 1. Treatment structure of the demonstration trials

Treatment	Year 1		Year 2	
	Crop	Inputs (/ha)	Crop	Inputs (/ha)
Farmer's practice SG 2000 package	Maize-hybrid	Farmers choice	Maize-hybrid	Farmers choice
	Maize-hybrid	9 bags of NPK 20:10:10 +2 bags of urea	Maize-hybrid	9 bags of NPK 20:10:10 +2 bags of urea
BNMS-Manure	Maize-hybrid	6 tons of animal manure; 4 bags of NPK 20:10:10+2 bags of urea	Maize-hybrid	6 tons of animal manure; 4 bags of NPK 20:10:10 + 2 bags of urea
Soybean/maize rotation	Soybean TGx 1448-2E	No fertilizer	Maize-hybrid	4 bags of NPK 20:10:10 +2 bags of urea

Results

Crop yields

In 2002 (year 1), maize grain yields averaged about 3000 kg ha⁻¹ in the improved systems, and about 2000 kg ha⁻¹ in the farmers' treatment (Figure 1). Average soybean grain yields were about 1500 kg ha⁻¹. However, wide variability was observed in maize and soybean grain yields obtained in the farmers' treatment and the improved systems in the 9 villages where the trials were conducted (Figure 2).

In 2003 (year 2), maize grain yields averaged about 2500 kg ha⁻¹ in the improved systems, and about

2000 kg ha⁻¹ in the farmers' treatment (Figure 1). BNMS-manure and soybean-maize rotation treatments out yielded the SG2000 and farmers' treatment. Similar to the 2002 observations, wide variability was observed in maize grain yields obtained in the farmers' treatment and the improved systems. The stability analysis furthermore indicated little difference in yield stability among the treatments across sites (Figure 2).

Quantity of manure and fertilizers applied by farmers

Generally, many of the farmers did not apply the recommended quantities of manure and fertilizers in the

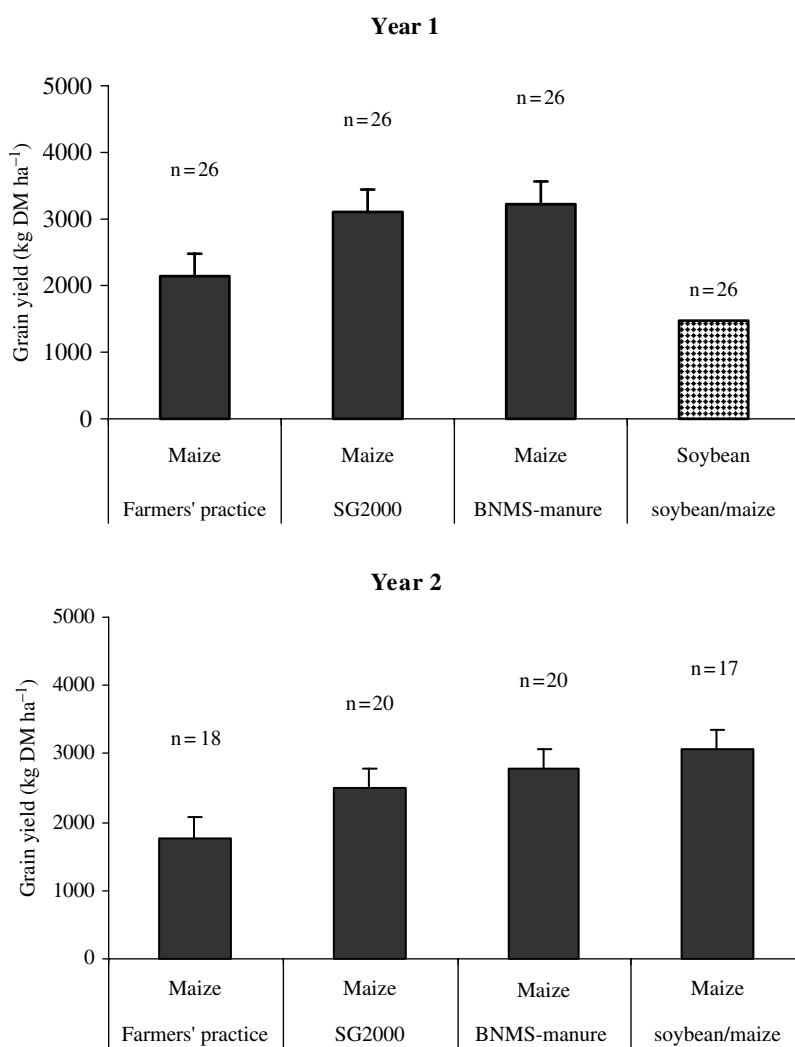

Figure 1. Maize and soybean grain yields in farmer-managed demonstration trials in northern Nigeria in 2002 (Year 1) and 2003 (Year 2). Error bars indicate standard errors of the treatment means.

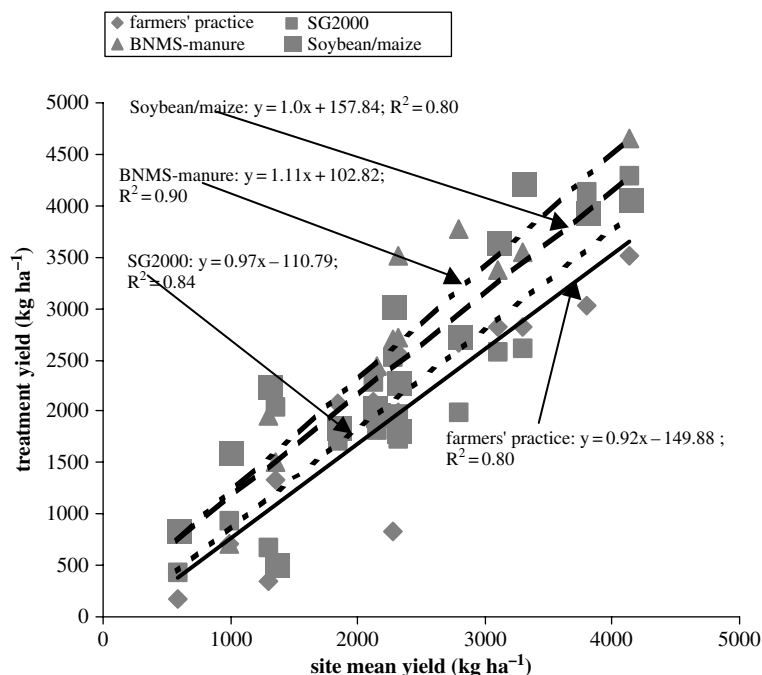

Figure 2. Relationship between mean site yield of maize and mean yields under three improved technologies and farmers' practice observed in demonstration trials in farmers' fields in the NGS, Nigeria 2003.

trials (Figure 3). Some farmers applied only marginal quantities or did not balance the supply of N, P and K, while others applied far too large quantities of fertilizers. The averages over all farmers however, came close to the quantities recommended in the SG2000 and BNMS manure systems.

To a large extent, there was no relationship between the quantities of manure and fertilizers applied and maize grain yields obtained (data not shown). There were few cases where farmers applied very high quantity of manure and fertilizers and obtained very poor maize yields in return and vice versa.

Economic assessment and farmer perception

The cost-benefit analysis carried out on the demonstration trials indicated that over the 2-year cycle the total variable costs were the highest for the BNMS manure and lowest for the soybean maize rotation and the gross field benefits were the highest for same BNMS-manure and lowest for the farmers' treatment (Table 2). The three improved systems outperformed the farmers' practice. Balancing the costs and the gross returns, the results showed that the soybean/maize rotation had the highest gross margins amounting to about

200% of the gross margins for the BNMS manure and SG2000 and 400% of the gross margins for the farmers' treatment. The soybean/maize rotation has the highest benefit: cost ratio and it dominates all the other treatments. SG2000 was second and BNMS manure was third. Manure is usually from the farm or collected free of charge from neighboring farms. If the cost of manure is not estimated at its opportunity cost, then BNMS manure becomes second in ranking after the soybean/maize rotation. The analysis also indicated that none of the systems yielded gross margins in Year 2 higher than those recorded in Year 1. Lower yields and lower farm gate prices observed in Year 2 could explain the poor economic performance of all the systems.

During the mid-season interviews, the general response from the farmers was that the introduced technologies were superior to the farmers' practice in terms of crop yield. The perceived high cost of mineral fertilizers in the season made the SG2000 maize system less attractive to the farmers. This perception was confirmed at the end of the season (Table 3) when none of the farmers agreed with the statement that the fertilizer input in the SG2000 technology is affordable. It is significant to note that all farmers indicated that they would use the soybean-maize and BNMS-manure technologies again, while only 50% of the farmers

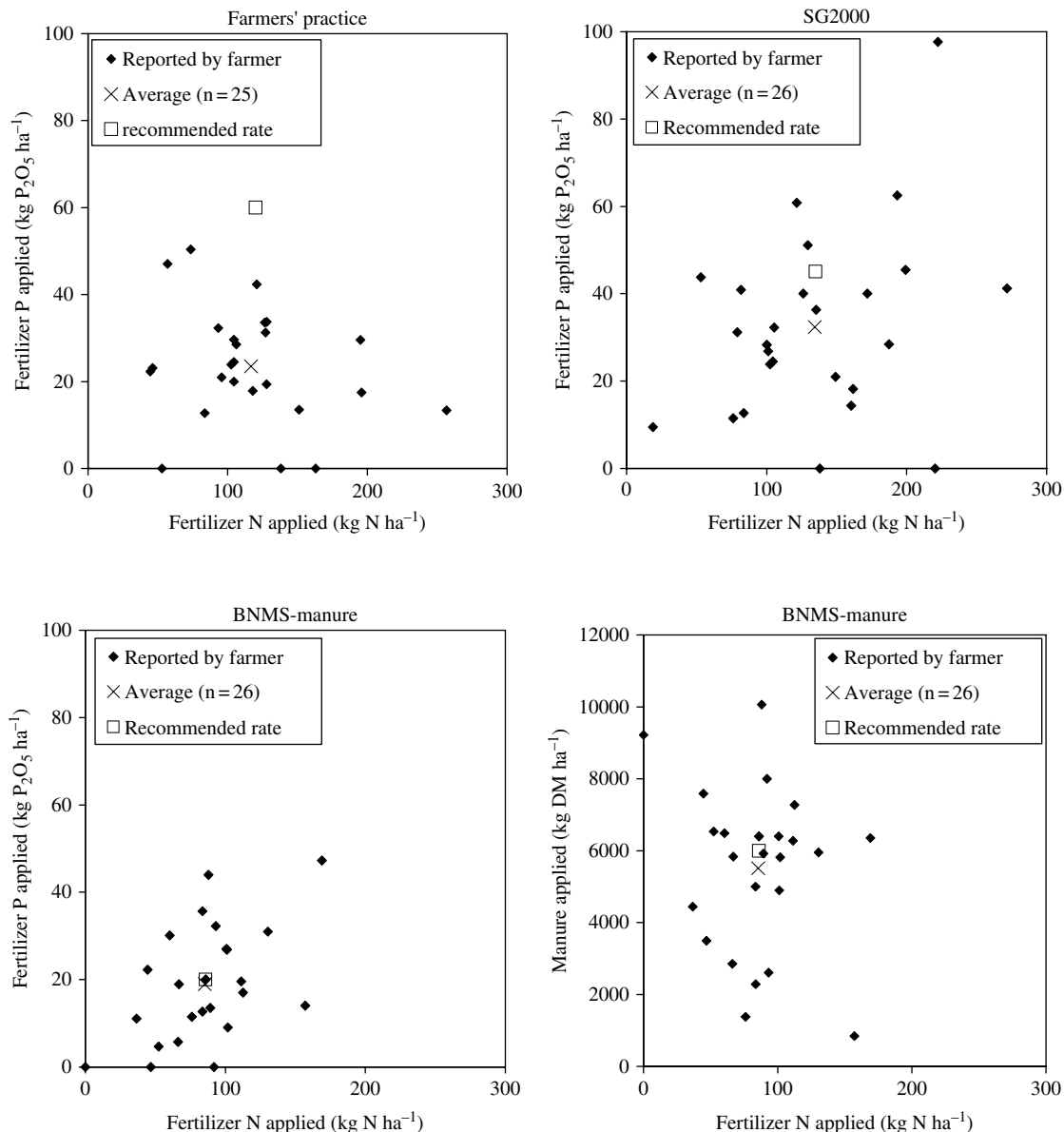

Figure 3. Quantity of N and P fertilizer, and manure applied to maize in the farmers practice, SG2000 system and the BNMS-manure system in the demonstration trials in 2002.

Note: Recommended rate shown in the graph for the farmers' practice is the one given by the Nigeria Federal Ministry of Agriculture and Natural Resources; recommended rates for the other treatments as given in Table 1.

would use the SG2000 system again. While both the soybean-maize and BNMS-manure technologies received an overall good appreciation by all farmers, some weaknesses of the BNMS-manure technology clearly came out: many felt that it does not suppress weeds (whereas the soybean-maize rotation does), and a few felt that the manure input is not available and affordable.

Discussion

Variable costs are considerably lower in the soybean-maize system because the soybean did not receive any fertilizer or manure, and because the maize that followed the soybean received a reduced quantity of fertilizer in view of the expected residual effects (residual N and rotational benefits) from the soybean crop.

Table 2. Partial budget analysis of the demonstration trials in 2002–2003, with costs and benefits actualized to year 2003

	Farmer's practice Maize/maize	SG2000 maize/maize	BNMS-Manure maize/maize	Soybean/maize
1st year of cycle (2002; costs¹ and benefits actualized to 2003)				
Crop in 2002:	<i>Maize</i>	<i>maize</i>	<i>maize</i>	<i>Soybean</i>
Number of farmers	25	26	26	26
Average yield (kg/ha)	2140	3106	3224	1474
Adjusted yield (kg/ha)	2033	2950	3062	1400
Field price (Naira/kg)	22.53	22.53	22.53	38.88
Gross field benefits (Naira/ha)	45811	66482	69004	54438
Total variable costs (Naira/ha)	34197	40987	48611	17085
Gross margin (Naira/ha)	11614	25495	20393	37353
2nd year of cycle (2003)				
Crop in 2003:	<i>maize</i>	<i>maize</i>	<i>maize</i>	<i>maize</i>
Number of farmers	18	20	20	17
Average yield (kg/ha)	1774	2511	2774	3065
Adjusted yield (kg/ha)	1685	2385	2636	2911
Field price (Naira/kg)	17.15	17.15	17.15	17.15
Gross field benefits (Naira/ha)	28906	40903	45203	49930
Total variable costs (Naira/ha)	28100	30249	36837	27174
Gross margin (Naira/ha)	806	10653	8366	22756
Average 2002–2003 (weighted average ² ; costs and benefits were actualized to 2003)				
Gross field benefits (Naira/ha)	38734	55361	58655	52656
Total variable costs (Naira/ha)	31645	36319	43492	21074
Gross margin (Naira/ha)	7090	19042	15164	31582
Benefit:Cost ratio	1.22	1.47	1.36	2.50

¹Exchange rate in 2003: 1 US\$ = 130 Naira, ²weighted average based on number of farmers in 2002 and 2003 practicing the given treatment.

Table 3. End of season farmers' evaluation of improved systems in the 2003 demonstration trials in northern Nigeria (percent)

Criterion	SG2000 (n = 20)	BNMS-manure (n = 20)	BNMS-soybean (n = 20)
Satisfied with yield of technology	75	90	90
Positive effect on soil fertility during season	20	95	100
Positive effect on soil fertility in next season	15	95	100
Suppresses weeds well	20	35	90
Suppresses striga well	5	80	85
Farmer encourages neighbours/relatives to practice it	50	95	95
Willing to use the technology again	50	95	95
Required input is available and affordable*	0	75	95
Overall good appreciation	29.4	82.5	93.8

*Input concerned is: fertilizer, manure and soybean seed.

The number of farmers cultivating improved soybean varieties in the dry savanna of Nigeria has increased by 228% between 2000 and 2003 (Sanginga et al., 2003). The dual-purpose, promiscuous (it nodulates effectively with indigenous rhizobia) soybean variety (TGx 1448-2E) is characterized by a high biomass production (2.3–3.0 t ha⁻¹), a high grain yield (1.7–2.3 t ha⁻¹) and a high N-fixation capacity (>60% nitrogen derived from atmosphere). Other features are low

harvest index, capacity of causing suicidal germination of *Striga hermonthica* in cereals that follow the year(s) after, and resistance to pod shattering and lodging compared to local varieties (Asafo-Adjei et al., 2001). Many farmers preferred the soybean-maize system, which also came out as the most profitable system in all but one economic indicator. This system is now being promoted by SG2000 and the ADPs in their extension programs in northern Nigeria. While many

farmers preferred the soybean-maize rotation system, others opted for the SG2000 or the BNMS-manure system, depending on the resources available to them and costs of inputs and outputs.

Many farmers indicated that the SG2000 technology was not affordable because of the high price of fertilizer. A good indicator for the relative cost of fertilizer is the ratios of the field price of nitrogen to the field price of maize grain. This ratio was 1.60 ($=29.65/18.58$) in 2002 and 3.80 ($=65.22/17.15$) in 2003. This is low compared to ratios for Asia ranging between an average of 2.1 in India and 7.9 in Thailand, and ratios for African countries ranging between an average of 2.8 in Zambia and 11 in Malawi (Mwangi, 1997). The key constraint these farmers face, therefore, is not a high fertilizer price, but low returns due to low maize yield (relative to the fertilizer investment they made). The perceived high fertilizer price therefore rather reflects the farmer's lack of cash and the low returns to their investment in fertilizer. With better fertilizer use practices and better field management (for example, timely weeding, correct plant densities, and the use of appropriate crop rotations), it should be possible to raise average maize yields in any of the 3 improved systems to around 4000 Mg ha⁻¹, yield levels now only reached in a few of the fields (Figure 2). With such yields, growing maize would become much more profitable.

The observation that maize grain yields in the combined applications of manure and mineral fertilizer were similar (2002) and slightly higher (2003) than in the sole mineral fertilizer treatment (SG2000) confirmed the observations of Vanlauwe et al. (2001b) and Iwuafor et al. (2002). The fact that in 2003 maize after soybean (soybean/maize rotation) yielded more grain than maize after maize (SG2000), notwithstanding that the maize in the first treatment received considerably less fertilizer than in the latter, points to large residual effects of the soybean crop on the following maize crop. Sanginga et al. (2002) reported that maize growing after soybean had significantly higher grain yield (1.2–2.3-fold increase) compared to maize after maize). However, they noted that the increased yields of maize following soybean were not entirely due to the carry-over of N from the soybean residue and to the soil-N conserving effect but also due to other effects. These “other effects” or “rotational effects” merit further investigations, so the mechanism by which soybean benefits a succeeding maize crop can be better understood (Sanginga et al. 2002). Grain legumes contribute less organic matter and N in their residues than green manure legume crops because

much of the N is removed in the grain, but are much more attractive to farmers both for their food values as well as for their good market value. The residual benefit from legumes to following cereal crops can often be greater than that expected from the amount of N in residues at harvest, indicating that both the N contributed from fallen leaves and below ground (Kasasa et al., 1999) as well as the rotational effects may be significant.

While the soybean-maize system attracted a lot of attention among farmers because of its low cost in terms of external inputs (no fertilizer to soybean, reduced rate to maize following soybean), there is concern that the reduced application rates of P and K may lead to a yield decline in the long run. With both maize and soybean grain yields around 3000 kg ha⁻¹ in this system, nutrient losses with the export of the grains over the 2-year cycle amount to about 30 kg P ha⁻¹ and 70 kg K ha⁻¹, which compares unfavorably with the input from fertilizer over the two years (none to soybean and 9 kg P + 17 kg K ha⁻¹ to maize in 2002 and 2003), given that there are also other nutrient losses due to erosion, K leaching, and the removal of stover. Potassium is often considered not to be a problem in northern Nigeria because of the nature of the soils and the annual net K inputs with the harmattan dust, of the order of 15–20 kg ha⁻¹ yr⁻¹ (McTainsh, 1980; Von Jahn et al., 1996). Some soybean varieties might furthermore be able to access P pools in the soils not accessible to maize. Yet, P exports exceeding P inputs will ultimately lead to soil P depletion. It might therefore be worthwhile to apply a modest dose of, say, 30 kg P ha⁻¹ as TSP, and maybe also some KCl to the soybean crop in the rotation in future demonstration trials.

Farmers indicated manure availability as the main constraint for the BNMS manure system. Fernandez-Rivera et al. (1993) have reported that because livestock densities in the moist savanna are generally low, the applicability of animal manure for crop production is limited. Hence, further research focuses on closed systems with crop-livestock integration (closed nutrient cycling). It could be expected that yield in the manure treatment will increase with time due to manure application (which raises soil organic matter content, stimulates microbial activities, and brings in nutrients that are only slowly released) (Djokoto and Stephens, 1961; Jones, 1971; Ridder and Keulen, 1990). Jones (1971) working in Samaru (NGS) of Nigeria reported that where farm yard manure was applied to the soil annually for nearly 20 years the soil organic matter content was increased four-folds. Since the OM is building up

gradually over time, it might be too early to compare the economic profitability of such resource management systems after a 2-year cycle of production.

The lower yields obtained in the farmers' treatment was due mainly to poor crop husbandry and management. The farmers' in some case even applied higher quantity of fertilizer in their treatment compared with SG2000 treatment. Many of the participating farmers did use sizable quantities of fertilizers in their farmers' practice plots, but not in a very efficient way. This might seem disappointing at first sight. But, as pointed out by Collinson (2001), the different outputs of a household, including those from off-farm employment, compete for the limited labour, cash and land available to the household. It is therefore rare that a single commodity will receive a technically ideal management. This calls for technologies that are robust, that will perform under less ideal management or on poor soils. The stability analysis indicated that the farmers' practice and the 3 improved technologies have a similar stability.

It is well known that huge differences exist in terms of availability of land, labour, livestock and cash for inputs between villages but also between farmers within the same village, and that this variability is further compounded by temporal variability in input and output prices and rainfall (Mortimore and Adams, 1999; Collinson, 2001). There also exist wide differences in the inherent soil fertility status of various farmers' plots. There is not only variability between households within a community but also between plots within a farm managed by a household. This inherent variability observed in farmers' plots might lead to potential differences in fertilizer response. It is therefore suggested that the 3 improved systems are promoted as basket of options where farmers could choose from depending on their resources and situations, and which they can adapt to their local circumstances. The clear extension message to go along with is that under the current market prices for maize and soybean, the soybean-maize rotation system is the most profitable one. Our data also indicated that the SG2000 and BNMS-manure systems could also be profitable, provided maize yield level above 4000 kg ha⁻¹ can be reached.

Acknowledgements

The authors are grateful to DGIC, the Belgian Directorate General for International Cooperation, for sponsoring this work as part of the collaborative project

between KU Leuven and IITA on 'Balanced Nutrient Management Systems for Maize-based Farming Systems and to messrs Mohammed O. Ibrahim and Ige, the various extension agents, and SG2000 zonal coordinators who assisted with data collection and organizing farmers' field days, to the GIS unit of IITA and to the farmers who participated in the trials.

References

- Asafo-Adjei B., Dashiell K. and Adekunle A.A. 2001. Characteristics of some released IITA soybean varieties and promising advanced breeding lines, Soybean varieties for sustainable agriculture in sub-Saharan Africa. IITA, Ibadan, Nigeria.
- Bennett J.G. 1980. Aeolian deposition and soil parent materials in northern Nigeria. *Geoderma* 24: 241–255.
- Collinson M. 2001. Institutional and professional obstacles to a more effective research process for smallholder agriculture. *Agricultural systems* 69: 27–36.
- Delauré S. 1998. Soil survey of two pilot villages in the NGS benchmark area of Nigeria. Ag. Eng. Thesis, Katholieke Universiteit Leuven, Belgium, 110 pp.
- Djokoto R.K. and Stephens D. 1961. Thirty long-term fertilizer experiments under continuous cropping in Ghana I. Crop yields and responses to fertilizers and manures. *Empire Journal of Experimental Agriculture* Vol. 29: No. 114 181–258
- Fernandez-Rivera S., Williams T.O., Hiernaux P., and Powell J.M. 1993. Faecal excretion by ruminants and manure availability for crop production in semi-arid West Africa. In: Powell J.M. et al. (Eds.) *Livestock and sustainable nutrient cycling in mixed farming systems of sub-Saharan Africa*. International Livestock Centre for Africa, Addis Ababa, Ethiopia. pp 147–170.
- Food and Agriculture Organization of the United Nations (FAO) 1999. Soil fertility initiative for sub-Saharan Africa. Proc. SFI/FAO Consultation, Rome. 19–20 Nov. 1999. FAO, Rome.
- Giller K.E. 2002. Targeting management of organic resources and mineral fertilizers: Can we match scientists' fantasies with farmers' realities? In: Vanlauwe B., Diels J., Sanginga N., Merckx R. (Eds.), *Integrated plant nutrient management in sub-Saharan Africa: From concept to practice*. CAB International, Wallingford, Oxon, UK. pp. 155–171.
- Guertal E.A., Raun W.R., Westerman R.L. and Boman R.K. 1994. Applications of stability analysis for single-site, long-term experiments. *Agronomy Journal* 86: 1016–1019.
- Iwuafor E.N.O., Aihou K., Jaryum J.S., Vanlauwe B., Diels J., Sanginga N., Lyasse O., Deckers J. and Merckx R. 2002. On-farm evaluation of the contribution of sole and mixed applications of organic matter and urea to maize grain production in the savanna. In: Vanlauwe B., Diels J., Sanginga N. and Merckx R. (Eds.), *Integrated plant nutrient management in sub-Saharan Africa: From concept to practice*. CAB International, Wallingford, Oxon, UK. pp. 185–197.
- Jagtap S.S. 1995. Environmental characterization of the moist lowland savanna of Africa. In: Kang B.T., Akobundu I.O., Manyong V.M., Carsky R.J., Sanginga, N. and Kueneman E.A. (Eds.) *Moist savannas of Africa. Potentials and constraints for crop production*. Proceedings of an IITA/FAO Workshop held from 19–23 September 1994. Cotonou, Republic of Benin, pp. 9–30.

- Jones M.J. 1971. The maintenance of soil organic matter under continuous cultivation at Samaru, Nigeria. *Journal of Agricultural Science, Cambridge* 77: 473–482.
- Kasasa P., Mpepereki S., Musiyiwa K., Makonese F. and Giller K.E. 1999. Residual nitrogen benefits of promiscuous soybeans to maize under field conditions. *African Crop Science Journal* 7: 375–382.
- Manyong V.M., Makinde K.O., Sanginga N., Vanlauwe B. and Diels J. 2001. Fertiliser use and definition of farmer domains for impact-oriented research in the northern Guinea savanna of Nigeria. *Nutrient Cycling in Agroecosystems*, 59: 129–141.
- McTainsh G.H. 1980. Harmattan dust deposition in northern Nigeria. *Nature* 286: 587–588.
- McTainsh G. 1984. The nature and origin of the aeolian mantles of central northern Nigeria. *Geoderma* 33: 13–37.
- Mortimore M., Adams W.M. 1999. Working the Sahel: environment and society in northern Nigeria. *Working the Sahel: environment and society in northern Nigeria*. Routledge, London and New York, 226 pp.
- Mwangi W.M. 1997. Low use of fertilizers and low productivity in sub-Saharan Africa. *Nutrient Cycling in Agroecosystems* 47: 135–147.
- Pieri C.J.M.G. 1992. Fertility of soils: A future for farming in the West African savanna. Springer-Verlag, Heidelberg, Germany.
- Raun W.R., Barreto H.J. and Westerman R.L. 1993. Use of stability analysis for long-term soil fertility experiments. *Agronomy Journal* 85: 159–167.
- Ridder N. de and van Keulen H. 1990. Some aspects of the role of organic matter in sustainable intensified arable farming systems in the West-African semi-arid-tropics (SAT). *Fertilizer Research* 26: 299–310.
- Sanginga N., Dashiell K.E., Diels J., Vanlauwe B., Lyasse O., Carsky R.J., Tarawali S., Asafo-Adjei B., Menkir A., Schulz S., Singh B.B., Chikoye D., Keatinge D. and Ortiz R. 2003. Sustainable resource management coupled to resilient germplasm to provide new intensive cereal–grain–legume–livestock systems in the dry savanna. *Agriculture, Ecosystems and Environment* 100: 305–314.
- Sanginga N., Okogun J.A., Vanlauwe B. and Dashiell K.E. 2002. The contribution of nitrogen by promiscuous soybeans to maize-based cropping systems in the moist savanna of Nigeria. *Plant and Soil* 241: 223–231.
- SAS Institute 1999. SAS OnlineDoc®, Version 8. SAS Institute Inc., Cary, NC, USA.
- Smaling, E.M.A., Nandwa, S.M., and Janssen, B.H. 1997. Soil fertility in Africa is at stake. In: Buresh R.J., Sanchez P.A. and Calhoun F. (Eds.), *Replenishing Soil Fertility in Africa*. Soil Science Society of America Special Publication No. 51, 47–61. Madison, WI, USA: Science Society of America/American Society of Agronomy.
- Stroup W.W., Hildebrand P.E. and Francis C.A. 1993. Farmer participation for more effective research in sustainable agriculture. In: Ragland J., Lal R. (Eds.), *Technologies for sustainable agriculture in the tropics*. Proceedings of two international symposia held in San Antonio, TX and Denver, CO, 1990 and 1991 respectively, ASA Special Publication No.56. American Society of Agronomy (ASA); Madison, Wisconsin; USA, pp. 153–186.
- Vanlauwe B., Wendt J. and Diels J., 2001a. Combined application of organic matter and fertilizer. In: Tian G., Ishida F., Keatinge J.D.H. (Eds.), *Sustaining Soil Fertility in West Africa*. SSSA Spec. Publ. no. 58, SSSA, Madison, WI, USA., pp. 247–279.
- Vanlauwe B., Aihou K., Aman S., Iwuafor E.N.O., Tossah B.K., Diels J., Sanginga N., Lyasse O., Merckx R. and Deckers J. 2001b. Maize yield as affected by organic inputs and Urea in the West African moist savanna. *Agronomy Journal*, 93(6): 1191–1199.
- Von Jahn R., Herrmann L. and Stahr K. (1996) Die Bedeutung äolischer Einträge für Bodenbildung und Standortseigenschaften im circumsaharischen Raum. (The importance of eolian additions for soil genesis and site qualities in circum-saharan areas.) *Zbl. Geol. Paläont. Teil I* (3/4): 421–432.
- Wall J.R.D. 1979. Land resources of the central Nigeria agricultural development possibilities. The Kaduna Plain Vol. 5. In: Wall J.R.D. (Ed.), *Land Resources Development Center, Ministry of Overseas Development, Tolworth Tower, Surbiton, KT6 7DY, Surrey, England, Land resource study* 29.

Impacts of vegetative contour hedges on soil inorganic-N cycling and erosional losses in Arable Steep-lands of the Central Highlands of Kenya

James K. Mutegi^{1*}, Daniel N. Mugendi², Louis V. Verchot¹ and James B. Kungu²

¹World Agroforestry Centre (ICRAF), P.O. Box 30677, Nairobi, Kenya; ²Department of Environmental Sciences, Kenyatta University, P.O. Box 43844, Nairobi, Kenya; *Author for correspondence, Email: mkinyua@cgiar.org

Abstract

Moderate to steep landscapes and severe soil, water and nutrient losses characterize over 40% of arable land in the central highlands of Kenya. To study the effectiveness of biological methods in management and enhancement of productivity of these arable steep-lands, we established contour double row hedges of sole *Calliandra*, *Leucaena* and napier and combination hedges of either *Calliandra* or *Leucaena* with napier. Hedges were established on slopes exceeding 5%, pruned regularly and the resulting biomass cut into fine pieces, which were then incorporated into the plots they served. We then evaluated these plots for inorganic-N changes with depth, soil conservation and soil loss/crop growth relationships. We observed accumulation of inorganic-N in the sub-soil in the control and napier plots but a reduction of sub-soil inorganic-N and its re-accumulation in the top-soil in the leguminous hedge plots after 20 months of trial. The first season on average, registered higher soil losses ($P = 0.004$) than the second season for treatments with hedges and vice versa for the control. During the first season there were significantly lower ($P < 0.001$) soil losses in plots with hedges relative to the control on slopes exceeding 10% but with the exception of napier, no significant differences among different types of hedges. We observed higher soil loss reduction in the combination hedge relative to individual tree hedges across the two seasons ($P = 0.012$). The relationship between cumulative soil loss and any of the four crop growth parameters i.e., grain weight, plant height, stover weight and total above ground biomass was negative, linear and highly significant ($P < 0.0001$), indicating decreased crop growth with soil loss. We conclude that there are heavy productivity losses as a result of soil erosion in arable steep-lands of the central highlands of Kenya and that well spaced, managed and combined contour hedges of leguminous trees and napier can reduce soil and nutrient losses from steep arable landscapes while simultaneously enhancing soil fertility

Key words: Contour hedges, inorganic-N, soil fertility, soil erosion, slope

Introduction

Recent studies in the central highlands of Kenya have revealed leaching of up to $300 \text{ kg N ha}^{-1}\text{yr}^{-1}$ (Mugendi et al., 2003) and a soil loss of $150\text{--}200 \text{ t ha}^{-1}\text{yr}^{-1}$ (Angima, 2000). At modest soil loss level of $10 \text{ t ha}^{-1}\text{yr}^{-1}$, it is estimated that soils lose on average 28 kg N , 10 kg P and $33 \text{ kg K ha}^{-1}\text{yr}^{-1}$ (Mantel and Van Engelen, 1999). Construction of physical soil conservation structures is expensive, laborious and time-consuming, and farmers do not have adequate

resources to invest in construction due to scarcity and multiple competing enterprises that characterize the households. This leads to low adoption of physical soil conservation technologies and hence heavy soil and nutrient losses. In addition to causing serious monetary losses to farmers, soil loss pollutes rivers and other water bodies potentially causing eutrophication, bottom water hypoxia and health hazards to both humans and animals (Cast, 1985; Duijvenbooden and Matthijsen; 1987; Justic et al., 1995). The usefulness of contour hedges as alternatives to physical soil conservation

structures has been demonstrated in Kenya (Raintree and Torres, 1986; Angima; 2000), Nigeria (Lal, 1989) and Java Indonesia (Pacardo and Montecillo, 1983). Basically, contour hedgerows control soil erosion by two mechanisms: (1) the hedgerows act as permeable barriers for slowing the flow of runoff and (2) The pruned biomass which is deposited as green manure between the hedges provides a protective cover from raindrop impact (Young, 1997).

Incorporating leguminous pruning residues from contour hedges improves soil fertility as these materials decompose and release nutrients, which translates into better crop production (Yemoah et al., 1986; Mugendi et al., 1999). Apart from improving the soil nutrient status, the pruned residues may also increase the soil organic matter content (Yemoah et al., 1986). This in turn improves the soil physical properties, creating favorable conditions for plant growth. In alley cropping trials of nine leguminous trees with maize in Hawaii, Rosecrane et al. (1992) reported an increase in maize yields with addition of tree pruning mulches. For every kilogram of nitrogen applied in form of mulch, approximately 12 kg of additional maize grain yield was produced. Most of these studies however, have been done on-station and therefore do not adequately simulate farm situations, where many uncontrolled factors account for poor performance of technologies that are successful on-station. Studies combining soil conservation aspects of agroforestry with nutrient enhancement/management and crop production which is the ultimate farmers' goal are also few.

To address these problems, we established an on farm trial with thirty-three farms in the central highlands of Kenya to determine the extent of top-soil loss through water erosion and the effectiveness of leguminous (*Calliandra calothyrsus* Meissner and *Leucaena trichandra* (Zucc.) Urban) and non leguminous (napier grass) vegetative contour hedges in soil conservation and nutrient enhancement.

Materials and methods

Description of the study area

This study was conducted in Chuka Division, Meru South District, which is a predominantly maize growing zone in the central highlands of Kenya. The area is on the eastern slopes of Mt Kenya at an altitude of approximately 1500 m above the sea level. Mean

annual rainfall is 1200 mm, distributed in two distinct seasons; the long rains (mid March to June) with an average precipitation of 650 mm and the short rains (mid October to December) with an average of 550 mm of rainfall. The average monthly maximum temperature is 25°C and the minimum is 14°C. The long-term monthly average temperature is 19.5°C. The soils of this area are mainly humic Nitisols (FAO, 1990) equivalent to Paleustalf in the USDA soil taxonomy system (Soil Survey Staff, 1990) with an average soil reformation rate of 2.2–4.5 Mg ha⁻¹ per year for the top 0–25 cm soil depth and 4.5–10 Mg ha⁻¹ per year for the 25–50 cm soil depth (McCormack and Young, 1981; Kilewe, 1987). They are deep, well weathered with friable clay texture with moderate to high inherent fertility.

Experimental design and methodology

Slopes and contours of 33 trial farms were determined by use of a clinometer and surveyors level, respectively. We evaluated mono-specific hedges of: *Calliandra*, *Leucaena*, napier and combination hedges of *Calliandra* + napier and *Leucaena* + napier. Plots with no hedges served as controls in each farm. Each hedge was made up of 2 rows of the above species arranged in interlocking/zig-zag manner with inter-row spacing of 0.25 m and intra-row spacing of 0.5 m. The plots were 10 m long with variable inter-hedge spacing calculated according to Young (1997) as follows:

$$W = 200/S\% \quad (1)$$

where W = inter-hedge spacing in metres and S% is the per cent slope. Where there was a napier + either *Calliandra* or *Leucaena*, the tree row preceded the napier grass row upslope. Each farm represented a block. The aim of blocking was to minimize the effects of site variation so that the treatment effects could be more accurately quantified using statistical tests. Care was taken to ensure that none of the plots fell on obvious convex zones of higher than average net erosion, or deposition zones of net sedimentation. We also trenched the plots on the upper lateral borders to prevent eroded sediments from up-slope areas from entering into the test plots.

After planting, the hedges were left for one year to become well established after which they were regularly pruned every 2 months to a height of 50 cm for

trees and 10 cm for napier. This was meant to ensure that they did not overgrow the crop and pose significant aboveground competition. The resulting biomass from any one hedge was cut into fine pieces and incorporated into the plot it served.

Soil sampling and analysis

Initial sampling for soil characterization was done on each farm before commencing the trials. The second set of soil samples was collected 20 months after establishment of the trials. For each collection date, at least six samples from each plot were collected. The six samples were mixed thoroughly and sub-sampled to form one composite sample. Field moist sub-samples were refrigerated at 4°C immediately after collection. Twenty grams of this field moist soil was extracted using 5 mL of 2N KCl within 3 days of collection (ICRAF, 1995) by shaking for 1 hour at 150 revolutions min^{-1} . The solution was filtered using a pre-washed Whatman No.5 filter paper. Soil water content was determined gravimetrically from stored field moist soil at the time of extraction and used for expression of inorganic-N on dry weight basis. Nitrate plus NO_2^- were determined by Cd reduction (Dorich and Nelson, 1984) with subsequent colorimetric determination of NO_2^- (Hilsheimer and Harwig, 1976). NH_4^+ was determined by the salicylate hypochlorite colorimetric method (Anderson and Ingram, 1993). Soil bulk density was determined by the undisturbed core method (Anderson and Ingram, 1993) and used for conversion of NO_3^- and NH_4^+ values from milligrams per kilogram to kilograms per hectare. Results are presented as inorganic-N (NO_3^- and NH_4^+).

Soil loss assessment

Soil loss was assessed by use of plastic erosion pins (FAO, 1993) fixed at a spacing of 2 × 2 m on each plot. The measurements were taken to the nearest millimeter, to allow any seasonal change in soil level to be clearly recognized. The resulting soil loss measurements were converted to t ha^{-1} by first calculating the volume of top-soil washed per plot by use of an equation:

$$V_{\text{plot}} = (\text{Average depth of washed soil}) \\ \times (\text{Plot length}) \times (\text{Alley width}) \quad (2)$$

The resulting volume was then multiplied by the bulk density to get the mass of soil lost, which was then converted to tons per hectare.

Maize yield assessment

Yield assessment was done on sub-plots of 5 × 5 m. Maize (*Zea mays* L.) was harvested by cutting at the root collar. It was weighed immediately to determine the total fresh weight (stover + unshelled cobs). The unshelled cobs were then separated from the stover. The total fresh weight of the stover was then determined and a sub-sample taken for dry weight determination. To obtain grain yields, grains were separated from the core by hand shelling, weighed, and a sub-sample taken for dry weight determination. Similarly, empty cobs (without grains) were weighed and a sub-sample taken for dry weight determination. To determine dry weight, the above sub-samples (cobs, stover and grain) were oven dried at 60°C for three days to a constant weight.

To determine the relationship between top-soil loss and maize crop growth, the control plots on fifteen of the farms where slope was between 10 and 20% were sampled. Control plots were used because it is on these plots where there was no treatment interference, while 10–20% slope was used because it was the most common slope in the study area and the soils on it were similar. These farms were sampled on the basis of farmer's adherence to proper and uniform agronomic aspects such as planting time, weeding, plant spacing/population 25 cm within row and 75 cm between rows) and planting the same seed variety (i.e., H513). H513 is one of the recommended and most widely used maize variety in the central highlands of Kenya. In addition to the yield parameters cited above, crop height was measured at maize tassling stage.

Maize yield assessment

Yield assessment was done on sub-plots of 5 × 5 m. Maize (*Zea mays* L.) was harvested by cutting at the root collar. It was weighed immediately to determine the total fresh weight (stover + unshelled cobs). The unshelled cobs were then separated from the stover. The total fresh weight of the stover was then determined and a sub-sample taken for dry weight determination. To obtain grain yields, grains were separated from the core by hand shelling, weighed, and a sub-sample taken for

dry weight determination. Similarly, empty cobs (without grains) were weighed and a sub-sample taken for dry weight determination. To determine dry weight, the above sub-samples (cobs, stover and grain) were oven dried at 60°C for three days to a constant weight.

To determine the relationship between top-soil loss and maize crop growth, the control plots on fifteen of the farms where slope was between 10 and 20% were sampled. Control plots were used because it is on these plots where there was no treatment interference, while 10–20% slope was used because it was the most common slope in the study area and the soils on it were similar. These farms were sampled on the basis of farmer's adherence to proper and uniform agronomic aspects such as planting time, weeding, plant population and planting the same seed variety (i.e., H513). H513 is one of the recommended and most widely used maize variety in the central highlands of Kenya. In addition to the yield parameters cited above, crop height was measured at maize tassling stage.

Statistical analysis

We analyzed data by use of GenStat for windows software (version 6.1, Rothamsted Experimental Station) (GenStat, 2002). We used analysis of variance (ANOVA) to test the hypothesis that leguminous contour hedges enhance soil inorganic-N, reduce soil losses and enhance crop yields. Protected least significant difference (LSD) at $P = 0.05$ (Fisher, 1935) was used to separate the means. The hypothesis that soil erosion is directly linked to losses in maize production was tested by regressing soil loss against various maize crop growth parameters. The best fit models were fitted into the data based on the one that had the highest R^2 to describe the nature of relationships between soil loss and maize crop growth parameters.

Results

Rainfall characteristics

We recorded a total annual rainfall of 1032 mm split into 467 mm during the long rains and 565 during the short rains. This annual rainfall was 14% lower than the long-term average for this area (i.e., 1200 mm). Rainfall peaks coincided with the months of April and November while the lowest precipitation was recorded in the months of February, June and September (Figure 1).

This monthly rainfall distribution is in agreement with the expected rainfall pattern for this area.

Soil inorganic-Nitrogen

Soil inorganic-N trend at the start of experiment was similar in all the treatments (Figure 2). There was a significantly higher concentration of inorganic-N at 30–90 and 90–150 cm depth relative to 0–30 cm depth during this sampling campaign ($P < 0.0001$).

During the second sampling, inorganic-N at the 0–30 cm depth was significantly higher in the *Leucaena* plots than the control and napier plots ($P < 0.05$) (Figure 3). During this sampling campaign, we observed significant reduction of inorganic-N accumulation at 30–90 and 90–150 cm depth in leguminous hedge plots relative to the control and napier ($P < 0.05$). Soil inorganic-N was also higher in the 0–30 cm depth in the sole *Leucaena* and *Calliandra* plots in comparison to the control and napier plots ($P < 0.05$).

Effects of hedges on soil erosion

Table 1 shows soil loss from plots with the different types of hedge during the first and second season, broken down by slope categories: 5–10, 10–20, 20–30 and >30%. The first season of soil loss estimation was done 12 months (short rains) after establishment of hedges while the second season was done 17 months (long rains) after hedge establishment. The first season on average, registered higher soil losses ($P = 0.004$) than the second season for treatments with hedges and vice versa for the control. Soil losses from plots on 5–10% slope had a narrow range (10–17 t ha yr⁻¹) for different treatments and seasons in comparison to other slopes and there were no significant differences between treatments ($P < 0.05$). During the first season there were significantly lower ($P < 0.001$) soil losses in plots with hedges relative to the control on slopes exceeding 10% but with the exception of napier, no significant differences among different types of hedges.

Consistent significant differences between hedges were observed during the second season on slopes exceeding 10% ($P < 0.05$). Napier hedges were the most effective at reducing erosion losses in both seasons (Table 1). We observed higher soil loss reduction in the combination hedge relative to individual tree hedges across the two seasons ($P = 0.012$). Soil loss on 10–20% slope category was higher than soil loss

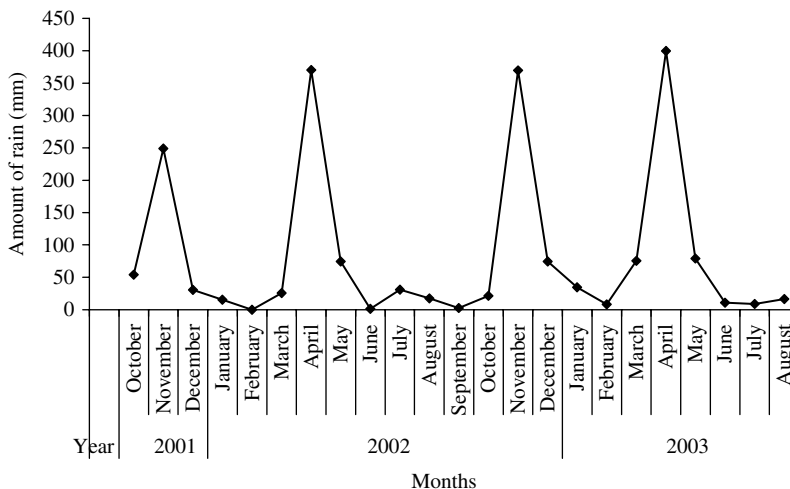

Figure 1. Rainfall pattern in Kirege Location during the study period.

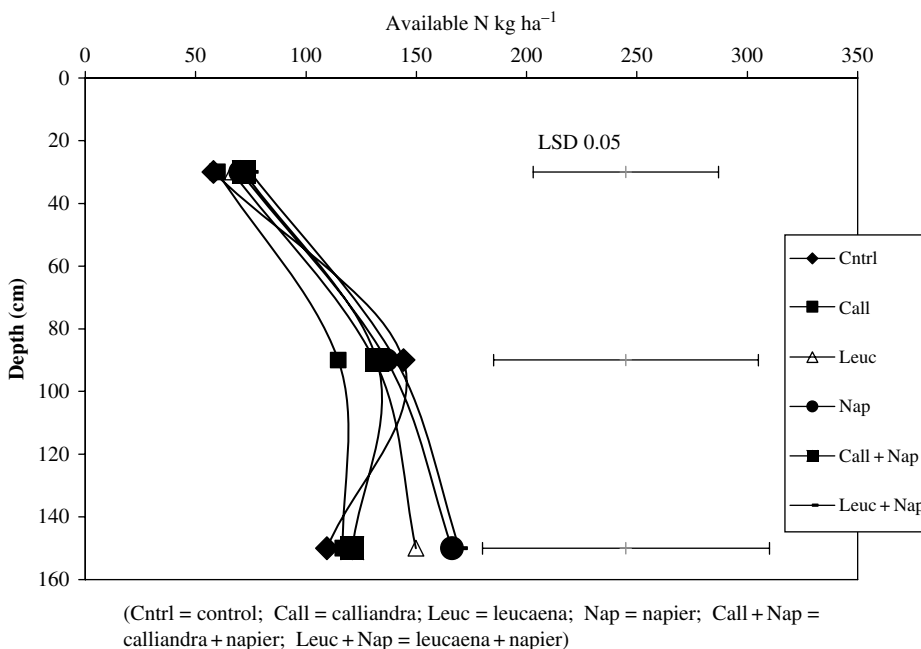

Figure 2. Inorganic-N concentration at three depths (0–30, 30–90 and 90–150 cm) of plots allocated to different treatments at the beginning of trials in September 2001 in Chuka farms.

on any other slope category ($P = 0.043$) although ordinarily we would have expected soil loss to increase with slope. In efforts to explain this unexpected phenomenon we analyzed the soil texture results on a per slope basis. We found significantly lower ($P < 0.001$) clay particles on the 10–20% slope relative to 20–30 and > 30% slope (Table 2).

Maize growth and yield

The presence of hedges had very little impact on maize crop yields during the first season (Table 3). Sole napier hedges suppressed yields during this season, but not during the second. The effects of the hedges were more apparent during the second season. A number

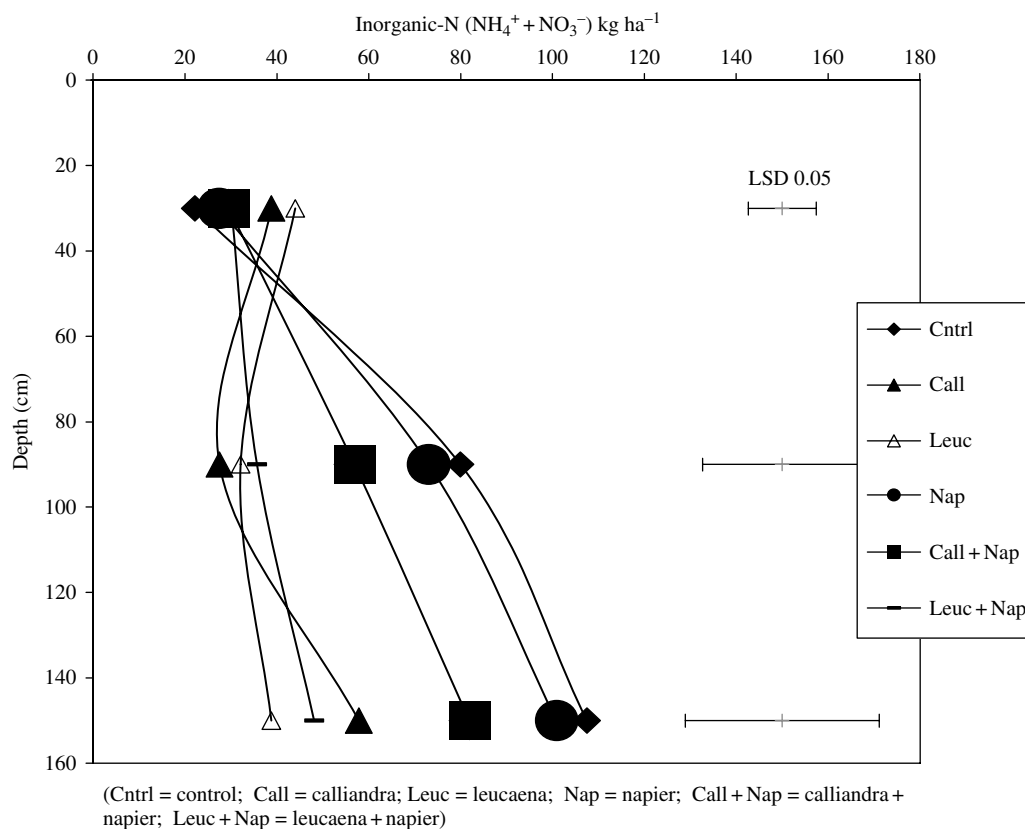

Figure 3. Inorganic-N concentration at three depths (0–30, 30–90 and 90–150 cm) of plots allocated to different treatments 20 months after establishment of trials in Chuka farms.

Table 1. Mean soil loss for first season (short rains 2001) and second season (long rains 2002) at Kirege location for different slope categories

Slope category (%)	5–10%	10–20	20–30	>30
Treatment	Soil loss (t ha ⁻¹)			
	First season (Time: 12 months after trial establishment)			
Control	16.80a ± 1.85	79.50a ± 3.96	77.40a ± 7.46	67.53a ± 7.25
Calliandra	15.52a ± 2.51	37.53b ± 1.54	34.87b ± 1.91	26.47b ± 2.91
Leucaena	14.70a ± 1.90	46.63b ± 4.40	37.50b ± 1.49	29.60b ± 8.38
Napier	12.64a ± 1.84	20.87c ± 2.69	22.90c ± 1.89	20.62b ± 2.76
Calliandra + Napier	13.57a ± 1.93	30.57b ± 2.49	26.50bc ± 2.10	26.58b ± 2.98
Leucaena + Napier	14.17a ± 0.94	35.18b ± 4.76	33.73b ± 1.79	21.78b ± 1.87
	Second season (Time: 17 months after trial establishment)			
Control	16.48a ± 1.67	79.61a ± 8.41	79.25a ± 7.63	78.90a ± 5.85
Calliandra	11.00a ± 1.52	26.14b ± 3.82	28.92b ± 3.15	22.18b ± 2.68
Leucaena	12.31a ± 1.64	29.68b ± 6.22	28.62b ± 3.58	23.50b ± 4.56
Napier	10.10a ± 2.13	10.21c ± 0.25	11.90c ± 0.44	9.67c ± 0.62
Calliandra + Napier	12.83a ± 1.98	17.70bc ± 1.85	14.15c ± 1.40	11.55c ± 0.931
Leucaena + Napier	10.66a ± 1.31	17.67bc ± 1.46	13.38c ± 0.34	12.98c ± 0.44

For each slope category and season, means within a column followed by different letters indicate significant difference based on Fisher's protected LSD test ($P = 0.05$). Values are means ± SE.

of treatments resulted in significant increases in yields, particularly when N-fixing trees were part of the system. Maize yield was higher during the second season than first season for all the treatments with vegetative hedges, but lower on the control.

The influence of soil loss on crop growth for each season was not consistent ($P < 0.05$). Cumulative soil losses on the 10–20% slope were 4 to >20 fold higher than the established tolerable soil loss limit of 10 t ha⁻¹yr⁻¹, implying that this was a highly fragile slope category in this region (Table 4). We observed significantly lower grain yield when cumulative soil loss exceeded 150 t ha⁻¹yr⁻¹ ($P = 0.01$) and significantly lower plant height and stover weight when cumulative soil loss exceeded 150 t ha⁻¹yr⁻¹ ($P < 0.0001$) (Table 4). Total aboveground biomass was significantly affected by any soil loss above 100 t ha⁻¹yr⁻¹ ($P < 0.0001$).

The relationship between cumulative soil loss and maize grain weight, stover weight, plant height,

and total above ground biomass was negative, linear and highly significant ($P < 0.0001$) (Figure 4).

Discussions

Effects of treatments on soil inorganic-N

The high sub-soil inorganic-N in napier and control treatments suggest a higher leaching of mineral-N from napier and control plots relative to other treatments. Plots with leguminous trees had a higher concentration of mineral-N at 0–30 cm depth than the control and napier probably as a result of interaction between their N fixing ability and deep nutrient capture (Van Noordwijk, 1989; Van Noordwijk et al., 1996). *Calliandra* and *Leucaena* roots deeper than napier (NAS, 1983; Mugendi et al., 2003) and therefore capture nutrients far beyond the reach of napier roots which are then transferred to the surface in form of leaf litter and prunings from their leaves and branches (Scroth G. 1994).

Low inorganic-N concentration at 20 months relative to initial levels can be attributed to weather and sampling time differences. The first sampling was done towards the end of September after a long dry spell and during land preparation for planting, while the second sampling (time 20 months) was done in July after the March to May rains (long rains) and July drizzles and at maize tussling stage. So probably alot of nitrate had been immobilized, leached, denitrified or even taken up by the growing crop at the time of sampling. Maize has the highest demand for N at the tussling stage (Karlen et al., 1988), so nitrogen would be locked in maize plant tissues at this time.

Table 2. Characteristics of soil texture at different slope categories in Kirege

Slope category (%)	Particle size (g kg ⁻¹)		
	Sand	Silt	Clay
5–10	318.6a ± 8.8	284.9ab ± 9.2	396.5a ± 1.5
10–20	304.3a ± 5.3	310.1a ± 7.8	385.6a ± 8.1
20–30	299.6a ± 9.5	279.8b ± 9.7	420.5b ± 3.7
>30	299.5a ± 7.3	300.5ab ± 11.3	411.0b ± 5.2

For each column, means followed by different letters indicate significant difference based on Fisher's protected LSD test ($P = 0.05$). Values are means ± SE.

Table 3. Maize yield at Kirege farms in plots served by various vegetative hedges during first and second season of the trial (2002 and 2003 respectively)

Treatment	Maize grain (t ha ⁻¹)		
	First season	Second season	Treatment mean
Control	2.2a ± 0.5	2.0b ± 0.3	2.1b
Calliandra	1.9a ± 0.4	2.9a ± 0.4	2.4ab
Leucaena	2.1a ± 0.6	3.1a ± 0.5	2.6ab
Napier	0.9b ± 0.1	2.1b ± 0.4	1.6b
Calliandra + Napier	2.2a ± 0.7	3.4a ± 0.8	2.8a
Leucaena + Napier	2.3a ± 0.8	3.6a ± 0.6	2.9a

For each column, means followed by different letters indicate significant difference based on Fisher's protected LSD test ($P = 0.05$). Values are mean yield ± SE.

Effects of hedges on soil conservation and maize crop performance

Lower soil losses during the second season on the contour hedge plots in comparison to the first season can be attributed to hedge species differences in stage of growth over the two seasons, and natural terrace formation. During the second season, hedges were more mature and therefore formed a more intact barrier to sufficiently obstruct runoff and enhance deposition of the sediment load carried down slope by the runoff. Natural terraces form along contour hedges, advance

Table 4. Relationship between various soil erosion classes with selected maize growth parameters in Kirege location

Soil loss (t ha ⁻¹ yr ⁻¹)	Grain weight (t ha ⁻¹)	Plant height (cm)	Stover weight (t ha ⁻¹)	*TAGB (t ha ⁻¹)
40–100	1.9a ± 0.2	247.3a ± 5.0	7.0a ± 0.2	10.2a ± 0.5
100–150	1.5a ± 0.2	259.0a ± 8.5	7.3a ± 0.2	4.1b ± 0.3
150–200	1.5a ± 0.2	226.2b ± 8.6	5.6b ± 0.5	3.2bc ± 0.1
>200	0.9b ± 0.3	190.1c ± 2.8	3.3c ± 0.2	1.6c ± 0.1

For each column, means followed by different letters indicate significant difference based on Fisher's protected LSD test (P = 0.05). *TAGB – total above ground biomass. Values are means ± SE.

and become more effective in obstruction of soil movement with time due to entrapment of washed off soil on the up-slope side of the hedge (Lal, 1989).

Napier hedge was overall the best vegetative hedge in soil conservation possibly due to its rhizomatous rooting characteristics. These rhizomatous roots spread out superficially over a large area reinforcing soil around them and bringing about an increase in cohesion and hence in shear strength (Dissemeyer and Foster, 1985). It also sprouts many tillers within a short time, forming an intact hedge. Lower soil loss values on combination hedge plots as compared to single tree species hedge could partially be attributed to presence of napier component and the positive interaction between napier and leguminous tree species which recycle and fix N (Young, 1997). This corroborates with the findings by National Research Council (1983) and Goudreddy (1995) that *Calliandra* and *Leucaena* improve soil fertility and hence enhance growth of associated crops, which in this case was napier.

The lower soil loss in the 20–30 and > 30% slope categories relative to 10–20% slope was most likely a result of higher clay concentration in the 20–30%, and >30% slope in comparison to the 10–20% slope. High clay content in the soil leads to surface sealing resulting in low soil particle detachment (Morgan and Rickson, 1995). High percentage of silt and fine sand decreases the raindrop energy required to break down soil clods increasing the susceptibility of soil particles to detachment and hence erosion (Morgan, 1986). This means that on steeper slopes, the ability of soil to resist detachment by runoff flow energy was probably higher than on the 10–20% slope category. Our estimate of lower soil loss on steeper slopes of up to 40% in the Central highlands of Kenya is consistent with observations by Angima (1996) and Angima et al. (2001) who

reported higher soil loss on 20% slope in comparison to 40% slope.

The negative regression relationships between soil loss and maize crop growth can be attributed to loss of top-soil, which is the most favorable soil for crop growth. The loss of top-soil inevitably reduces soil productivity, which in turn deters crop growth because the top-soil is usually the most fertile, containing natural plant nutrients, humus and any fertilizers that farmers have applied (Lal, 1989). The fact that soil loss negatively affects crop growth parameters and contour hedges reduce soil loss implies that contour hedges can enhance crop production on sloping landscapes. This is consistent with observations of yields and other crop growth parameters decline as a function of soil erosion by (Gachene et al., 1998; Pesant and Vigneux, 1992; Andraski and Lowry, 1992).

Conclusion

This study showed that generally majority of farms in central highlands of Kenya lose more than the established tolerable amount of soil (10 t ha⁻¹yr⁻¹). We demonstrated a substantial reduction in crop yield as a function of soil loss and ability of leguminous contour hedges to simultaneously control soil erosion, enhance soil inorganic-N and improve crop yields. Although soil loss was negatively correlated to crop growth, the high efficiency of napier in soil conservation did not translate into high crop yields. We can therefore conclude that the higher maize yield observed in leguminous tree hedge plots was a result of interaction between soil fertility improvement by incorporated leguminous biomass and management of both

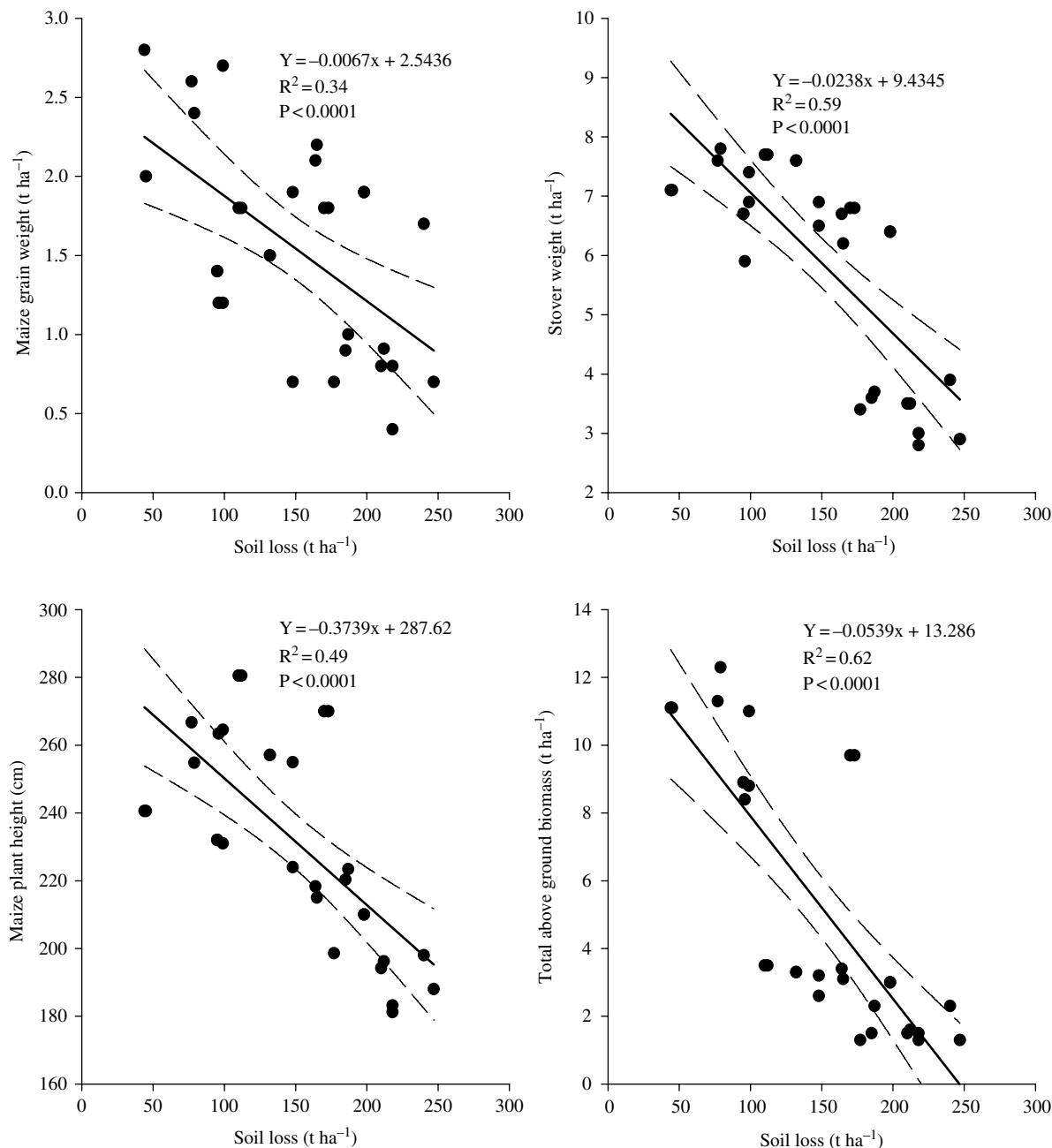

Figure 4. Relationship between cumulative soil loss and various maize crop growth parameters. Dotted lines represent the 95% confidence interval for regression.

added and existing soil nutrients through soil conservation by these hedges. Adoption of these technologies by small scale resource poor steep-land farmers would therefore save them the cost of purchasing expensive inorganic fertilizers and improve crop yields while maintaining land quality and checking pollution of water bodies by eroded sediments and nutrients.

Acknowledgement

We gratefully acknowledge the support of NARFP and ICRAF laboratory staff in soil sampling and analysis respectively. We thank Kirege farmers for allowing us to use their farms for these trials. Lastly but not the least we are very grateful to Rockefeller Foundation (ACA

section) for enabling the whole process of this research through funding.

References

- Anderson J.M. and Ingram J.S. 1993. Tropical Soil Biology and Fertility: Handbook of Methods. CAB International, Wallingford, UK.
- Andraski B.J. and Lowery B. 1992. Erosion effects on soil water storage, plant water uptake and corn growth. Soil Science Society of America Journal 56: 1911–1919.
- Angima, S.D. 1996. Potential use of contour *Calliandra calothyrsus* hedges with napier grass (*Pennisetum purpureum*) for soil erosion control in a high potential area of Embu, Kenya. MSc thesis, Kenyatta University, Kenya.
- Angima S.D. 2000. Soil erosion prediction using RUSLE in central Kenya. Ph.D. Dissertation, Purdue University, USA.
- Angima S.D., Stott D.E., O'Neill M.K., Ong C.K. and Weesies G.A. 2001. Use of *Calliandra*-napier contour hedges to control soil erosion in central Kenya. Agriculture, Ecosystems and Environment 91: 15–23.
- Cast T. 1985. Agriculture and ground water quality. Council for Agricultural Sciences and Technology Report. 62, pp.103.
- Dissemeyer G.E. Foster G.R. 1985. Modifying the universal soil loss equation for forestland. In: Soil Erosion and Conservation (Swaify S.A., Moldenhauer W.C and Lo A. (eds). Soil Science Society of America, Ankeny, IA, Madison, pp. 480–95.
- Dorich R.A. and Nelson D.W. 1984. Evaluation of manual cadmium reduction methods for determination of nitrate in potassium chloride extracts of soil. Soil Science Society of America Journal: 48: 72–75.
- Duijvenbooden W.V. and Matthijsen C.M. 1987. Basis document nitraat. Natural institute of public health and environmental hygiene. Bilthoven: The Netherlands.
- FAO 1990. Soil Map of the World. Revised Legend. World Resources Report 60. FAO, Rome.
- FAO 1993. Field Measurement of Soil Erosion and Runoff, Soils Bulletin No. 68. FAO, Rome.
- Fisher R.A. 1935. The Design of Experiments, 1st ed. Oliver and Boyd. Edinburg and London.
- Gachene C.K., Mbuvi J.P., Jarvis N.J. and Linner H. 1998. Maize yield reduction due to erosion in a high potential area of central Kenya highlands. African Crop Science Journal 6: 29–37.
- GenStat 2002. Version 6.1, Lawes agricultural trust, Rothamstead Experimental Station, UK.
- Goudreddy B.S. 1995. Fodder trees p.46–48. In: Naadagouder B.S., Horst W.J., Kuhne R. and Kang B.T. (ed) 1995. Nutrient use in *Leucaena leucocephala* and *Cajanus cajan* in maize/cassava alley cropping on Terre de Barre, Benin. Alley farming research and development. Proceedings of the International Conference on Alley Farming 14–18 September 1992. Ibadan, Nigeria, pp. 122–136.
- Hilsheimer R. and Harwig J. 1976. Colorimetric determination of nitrate from meat and other foods: an alternative colour reagent for carcinogenic 1-naphthylamine and an improved extraction method. Can. Inst. Food Sci. Technol. J. 9: 225–227.
- ICRAF 1995. International Centre for Research in Agroforestry (ICRAF). Laboratory Methods for Soil and Plant Analysis. Nairobi, Kenya.
- Justic D., Rabailis N.N., Turner R.E. and Dortch Q. 1995. Changes in nutrient structure of river dominated coastal waters: Stoichiometric nutrient balance and its consequences. Estuarine, Coastal and Shelf Science 40: 339–356.
- Karlen D.L., Flannery R.L. and Sadler E.J. 1988. Aerial accumulation and partitioning of nutrients by corn. Agronomy Journal 80: 232–242.
- Kilewe A.M. 1987. Prediction of erosion rates and effects of top-soil thickness on soil productivity. Ph.D. Dissertation, University of Nairobi, Kenya.
- Lal R. 1989. Agroforestry systems and soil surface management of a tropical Alfisol. Water runoff, soil erosion and nutrient loss. Agroforestry Systems 8: 97–111.
- Mantel S.D. and Van Engelen V.M. 1999. Assessment of the impact of water erosion on productivity of maize in Kenya: an Integrated modeling approach. Land Degradation and Development 10: 577–592.
- McCormack D.E. and Young K.K. 1981. Technical and societal implications of soil loss tolerance. In: Morgan R.P.C. (Ed.). Soil Conservation Problems and Prospects. Wiley, Chichester, UK, pp. 365–376.
- Morgan R.P.C. 1986. Soil erosion and conservation. Essex: Longman Group.
- Morgan R.P.C. and Rickson R.J. 1995. Water erosion control. In: Morgan R.P.C. and Rickson R.J. (eds). Slope stabilization and erosion control: A Bioengineering Approach. E & FN Spon Publishers: London.
- Mugendi D.N., Nair P.K., Mugwe J.N., O'Neill M.K. and Woomer P.L. 1999. Alley cropping of Maize with *Calliandra* and *Leucaena* in sub humid highlands of Kenya. Part 2: Biomass decomposition, N mineralization, and N uptake by maize. Agroforestry Systems 46: 51–64.
- Mugendi D.N., Kanyi M.K., Kung'u J.B., Wamicha W. and Mugwe J.N. 2003. Mineral-N movement and management in an agroforestry system in central highlands of Kenya. Soil Science Society of East Africa Conference, 4th to 8th December 2000, Mombasa, Kenya, pp. 287–297.
- National Academy of Sciences (NAS) 1983. *Calliandra. A Versatile Small Tree for Humid and Tropics*. National Academy Press: Washington, DC. p. 42.
- Pacardo E.P. and Montecillo L. 1983. Effects of corn/Ipil-Ipil cropping systems on productivity and stability of upland agroecosystems. Annual Report, UPLB PCARRD Res. Project, Philippines.
- Pesant A.R. and Vigneux J. 1992. Restoring productivity to artificially eroded soils by use of beef cattle manure. In: Hurni H and Tato K. (Eds). Erosion conservation and small scale farming. Walsworth Publishing Co. Inc.: Kansas, pp. 431–438.
- Raintree J.B. and Torres F. 1986. The agroforestry in farming systems perspectives: The ICRAF approach. IARC'S workshop on FSR, 17–21 Feb. 1986, ICRISAT, Hyderabad, India.
- Rosecrane R.C., Brewbaker J.L. and Fownes J.H. 1992. Alley cropping of maize with nine leguminous trees. Agroforestry Systems 17: 159–169.
- Schroth G. 1994. Above and belowground interactions in alley cropping in *Gliricidia sepium* as compared to conventional and mulched sole cropping in the West African rainforest zone. Ph.D. Dissertation. University of Bayreuth, Bayreuth, Germany.
- Soil Survey Staff 1990. Keys to soil taxonomy. SMSS Tech. Monograph No.19, 4th edition.

- Van Noordwijk M. 1989. Rooting depth in cropping systems in the humid tropics In Relation to nutrient use efficiency. P. 129–144. In van der Heide J. (ed.) nutrient management for food crop production in tropical farming systems. Inst. For soil fertility. Haren: The Netherlands.
- Van Noordwijk M., Lawson G., Samaore A. and Groot J.J.R. 1996. Root distribution of trees and crops: Competition and/or complementarity. In: Ong CK and Huxley P (eds) Tree Crop Interactions: A Physiological Approach, pp 319–364. CAB International, Wallingford, UK.
- Yemoah C.F., Agboola A.A. and Wilson G.F. 1986. Nutrient contribution and maize performance in alley cropping systems. Agroforestry Systems 4: 247–254.
- Young A. 1997. Agroforestry for Soil Management (2nd Edition). CAB International, Wallingford, UK.

Relationships between rhizobial diversity and host legume nodulation and nitrogen fixation in tropical ecosystems

Abdullahi Bala^{1,*} and Ken E. Giller²

¹Department of Soil Science, Federal University of Technology, Minna, PMB 65, Minna, Nigeria;

²Department of Plant Sciences, Plant Production Systems, Wageningen University, P.O. Box 430, 6700 AK, Wageningen, The Netherlands; *Author for correspondence (fax: +234-9-4130973; e-mail: abdullahi_bala@yahoo.com)

Key words: Ecological adaptation, N₂-fixation, Nodulation, Rhizobial diversity

Abstract

With recent advances in rhizobial phylogeny, questions are being asked as to how an ecological framework can be developed so that rhizobial classification and diversity could have greater practical applications in enhancing agricultural productivity in tropical ecosystems. Using the results of studies on tropical rhizobia which nodulate agroforestry tree legumes, three ecological aspects of rhizobial biodiversity were used to illustrate how its potential can be exploited. The results showed that legumes nodulate with diverse rhizobial types, thus contributing to the success of legumes in colonising a wide range of environments. There was an apparent shift in the relative dominance of rhizobia populations by different rhizobial types as soil pH changed. The *Rhizobium tropici*-type rhizobia were predominant under acidic conditions, *Mesorhizobium* spp. at intermediate pH and *Sinorhizobium* spp. under alkaline conditions. The *R. tropici*-type rhizobia were the most effective symbiotic group on all the host legumes. However, strains of *Sinorhizobium* spp. were as effective as the *R. tropici* types in N₂-fixation on *Gliricidia sepium*, *Calliandra calothyrsus* and *Leucaena leucocephala*; while *Mesorhizobium* strains were equally as effective as the *R. tropici* types on *Sesbania sesban*. Classification of rhizobia based on phenotypic properties showed a broad correlation with groupings based on 16S rRNA sequence analysis, although a few variant strains nested with the dominant groups in most of the clusters. Some of the phenotypic characters that differentiated different rhizobial groups are highlighted and a case is made for the need to standardise this method.

Introduction

The family Leguminosae is one of the most successful families of angiosperms, with about 650 genera and 20,000 species (Sprent 1995) and a cosmopolitan distribution (Raven and Polhill 1981). The success of legumes can in part be attributed to their ability to colonise environments with low soil nitrogen because of their symbiotic association with N₂-fixing rhizobia (Sprent 1994).

The current rhizobial taxonomy has 6 genera and 29 species, most of which were described in the last decade using rhizobia isolated from tropical legume species (Giller 2001). In spite of this relatively high turnover of rhizobial groups, it is likely that we are still orders of magnitude away from a true assessment of the diversity of tropical rhizobia (Giller 2001). This has led to questions being asked as to how this can be explored to enhance agricultural productivity in the tropics. This requires

This article has been previously published in the journal "Nutrient Cycling in Agroecosystems" Volume 76 Issues 2–3.

an ecological approach, which can help us understand the relative environmental tolerances of the different rhizobial types and thus allow for predicting their ecology (Andrade et al. 2002). Such an approach is pertinent in view of the fact that the success of rhizobial inoculation, for instance, depends on inoculant strain competitiveness and persistence, which are both linked to the saprophytic competence of the strain.

Although the description of rhizobial genera and species is now essentially based on sequence analysis of small subunit ribosomal DNA, phenotypic characterisation still remains an essential ingredient of rhizobial classification (Graham et al. 1991). Since the capacity of many laboratories in developing countries is limited to the use of phenotypic characterisation, there is a need to standardise this method as a simple, low-level technology protocol for routine assessment of rhizobial diversity.

The aim of this paper is to look at rhizobial diversity from an ecological perspective, in terms of the relationship between rhizobial types and (i) nodulation (host range), (ii) N₂-fixation (effectiveness) and (iii) adaptation to soil acidity as functional attributes of rhizobial types in soil populations. Soil acidity was chosen for this study because it was found to be a major determinant of rhizobia diversity (Bala et al. 2003a). The other objective is to determine some of the phenotypic characters that can be used in differentiating groups of rhizobia. The results used are based on studies of rhizobia isolated from tropical soils of Africa, Asia and Central and Southern America using four legume tree species that are commonly used in agroforestry. These were *Calliandra calothyrsus*, *Gliricidia sepium*, *Leucaena leucocephala* and *Sesbania sesban*.

Materials and methods

Soil sampling and analysis

Soils were sampled from 13 sites that had no history of inoculation in tropical areas of Africa, Asia and Latin America. The sites ranged from cultivated fields to secondary forests, which were located in sub-humid to humid tropical climates (Table 1). None of the legume host plants used for the study was growing at any of the sites at the

time of soil sampling. Soils were sampled during the rainy season or at the beginning of the dry season. At each site, soil cores were sampled at 0–15 cm depth at several points and were bulked and thoroughly mixed to get composite samples. Precaution was taken to avoid cross-contamination of soils from different sites. Moist soil samples that were not going to be used immediately were stored in loosely tied plastic bags and stored at 4 °C. None of the soils was stored for more than 11 days after sampling before use. Routine soil analysis was carried out according to the TSBF manual (Anderson and Ingram 1993). Soil rhizobia populations were estimated using the most probable number (MPN) method (Vincent 1970). An automatic C/N Roboprep analyser coupled to a 20–20 mass spectrometer (Europa Scientific, Crewe, UK) was used for the measurement of total soil C and N in soils, and was also used to measure total N in plants as an estimate of N₂ fixed.

Seed sources and treatment

Seeds of *G. sepium* (provenance Retalhuleu) were obtained from the International Centre for Research on Agroforestry (ICRAF), Kenya, and those of *L. leucocephala* (provenance Gede) and *C. calothyrsus* (provenance Ex Maseno) from the Kenya Forestry Seed Centre. *S. sesban* seeds were obtained from Centrale de Graines Forestieres, Rwanda.

Seeds were immersed in concentrated H₂SO₄ for periods of 25–30 min for scarification and surface sterilisation, followed by thorough rinsing with sterile distilled water. Scarified seeds were germinated on 1% water agar at a temperature of 28 °C.

Nodule sampling and rhizobial isolation

Two-day old seedlings were aseptically transferred to growth pouches containing N-free solution and inoculated with serial dilutions of each soil. Seedlings were also transplanted into 6 cm diameter plastic pots containing 100 g of each soil and an equal weight of acid (0.1 M HCl) washed sand. The potted plants were irrigated with N-free nutrient solution. The seedlings were maintained in growth chamber as described by Bala et al. (2003b) for a period of 12 weeks.

Table 1. Selected site characteristics and physico-chemical properties of the soils sampled in various tropical countries.

Site and country	Vegetation and site history	Mean annual rainfall (mm)	Mean annual temp (°C)	pH in H ₂ O (1:2.5)	Organic Carbon (%)	Total N (%)	Available P (mg kg ⁻¹)	Exch. bases (cmol _c kg ⁻¹)	Exch. acidity (cmol _c kg ⁻¹)	Sand (%)	Silt (%)	Clay (%)
<i>Brazil</i>												
Itabela	Atlantic forest	1100	34	4.41	1.17	0.10	0.55	2.00	0.63	82	2	16
<i>Costa Rica</i>												
San Isidro	Moist deciduous Forest	2000	34	4.31	3.27	0.39	0.55	7.65	6.73	44	38	18
<i>Indonesia</i>												
Bromo-crater	Montane forest	2750	32	4.15	1.14	0.18	6.95	1.05	2.71	81	17	2
Lampung	Rainforest	2500	32	4.54	2.08	0.16	1.95	3.01	0.93	66	9	25
<i>Kenya</i>												
Maseno	Maize field	2500	22	5.46	1.46	0.16	1.60	530	0.49	33	20	47
<i>Malawi</i>												
Chitala River	Maize field	750	28	5.75	1.02	0.07	0.45	7.49	0.09	65	9	26
<i>River</i>												
Chitedze	Maize field	1000	25	5.14	2.31	0.15	0.55	12.03	0.07	51	21	28
Salima	Miombo woodland	800	28	5.89	0.98	0.07	19.00	7.95	0.44	71	9	20
<i>Mexico</i>												
Yucatan	Secondary forest	1000	26	7.48	4.44	1.57	0.55	120.36	0.12	29	34	37
<i>Nigeria</i>												
Omne	Secondary rainforest	2300	32	4.18	1.01	0.11	12.95	0.85	1.81	75	8	17
<i>Zambia</i>												
Banda	Maize field	750	27	5.15	0.51	0.09	18.5	1.08	0.50	80	10	10
Fisi village	Maize field	800	27	5.07	1.42	0.11	13.5	8.37	0.51	72	10	18
Katete FTC	Maize field	800	27	5.05	0.56	0.05	11.5	3.29	0.43	78	8	14

At harvest, root nodules were randomly sampled from roots of potted plants and those inoculated with serial soil dilutions to ensure the sampling of less common rhizobia (Bala et al. 2001). Rhizobia were isolated from root nodules on yeast extract mannitol agar (YMA) containing Congo Red (Vincent 1970).

Rhizobia genetic diversity

Genetic diversity of rhizobia was determined using PCR-restriction fragment length polymorphism (RFLP) of the 16S rRNA gene and the internally transcribed spacer (ITS) region between the 16S and 23S rRNA as earlier described (Bala et al. 2002). Restriction fragment length polymorphism of 16S rRNA was used to assign the isolates into ribosomal DNA groups, representatives of which were subjected to an almost full-length DNA sequencing (Bala et al. 2003b). Variations in the RFLP patterns of ITS fragments were used to differentiate isolates as “strains”.

Phenotypic characterisation of strains and numerical analysis

Ninety six rhizobia representing different ITS RFLP groups and eight reference strains of the genera *Rhizobium*, *Mesorhizobium* and *Sinorhizobium* were used for phenotypic characterisation. Differentiation using colony characteristics was as described previously (Mpeperekki et al. 1997; Odee et al. 1997). The ability of isolates to utilise various carbon and nitrogen substrates was assessed using the method of Amarger et al. (1997).

A total of 40 variables, including colony and symbiotic characteristics of isolates and substrate utilisation, were used for numerical analysis. A cluster analysis of the phenotypic traits was based on matrix and Euclidean distance using the SAS programme.

Results

Distribution of rhizobia types and host nodulation

The rhizobial types that nodulated *C. calothyrsus*, *G. sepium* and *L. leucocephala* in four soils are

shown in Figure 1. Apart from *G. sepium* in the Chitala soil, the legumes were nodulated by rhizobia in all four soils. *S. sesban* failed to nodulate in any of the soils hence its exclusion from Figure 1. Host legumes were nodulated by at least four groups of rhizobia in the Yucatan soil, three in the Itabela and Chitala soils and two in the Lampung soil.

The *R. tropici* group was isolated in all the soils; the mesorhizobia were isolated in three soils and the *R. etli* group in two soils. The *Sinorhizobium* and *Agrobacterium* groups were limited to the Yucatan soil. All the rhizobial groups were isolated from all the hosts apart from the *R. etli* group that was not sampled from *C. calothyrsus*. The host legumes were also nodulated to various degrees by one or more of the rhizobia groups in the remaining nine soils (data not shown).

Effect of soil acidity on rhizobia groups

Changes in soil pH appeared to be associated with shifts in the dominant rhizobial groups within soil populations (Figure 2a). Below a pH of 4.2, *Rhizobium* spp., made up of members of the *R. etli*, *R. giardinii* and *R. gallicum* groups, dominated the populations, while the *R. tropici* group was dominant within a pH range of 4.2–5.0. The *Mesorhizobium* spp. were the most dominant at pH range of 5.0–6.5, while the *Sinorhizobium* spp. formed the bulk of the populations above a pH of 6.5.

There was also an apparent shift in population dominance as the exchangeable acidity changed, with the *Mesorhizobium* spp. being dominant when exchangeable acidity was below 2 cmol kg⁻¹ (Figure 2b). Above this value, the *R. tropici* group dominated the populations. The *Rhizobium* spp. and *Sinorhizobium* spp. appeared not to be dominant at any exchange acidity range.

Symbiotic effectiveness of rhizobia groups

Figure 3 shows the distribution of rhizobia types among the groups of strains that were characterised in an earlier study (Bala and Giller 2001) as being effective or very effective when inoculated on their hosts. Out of the 20 strains inoculated on *C.*

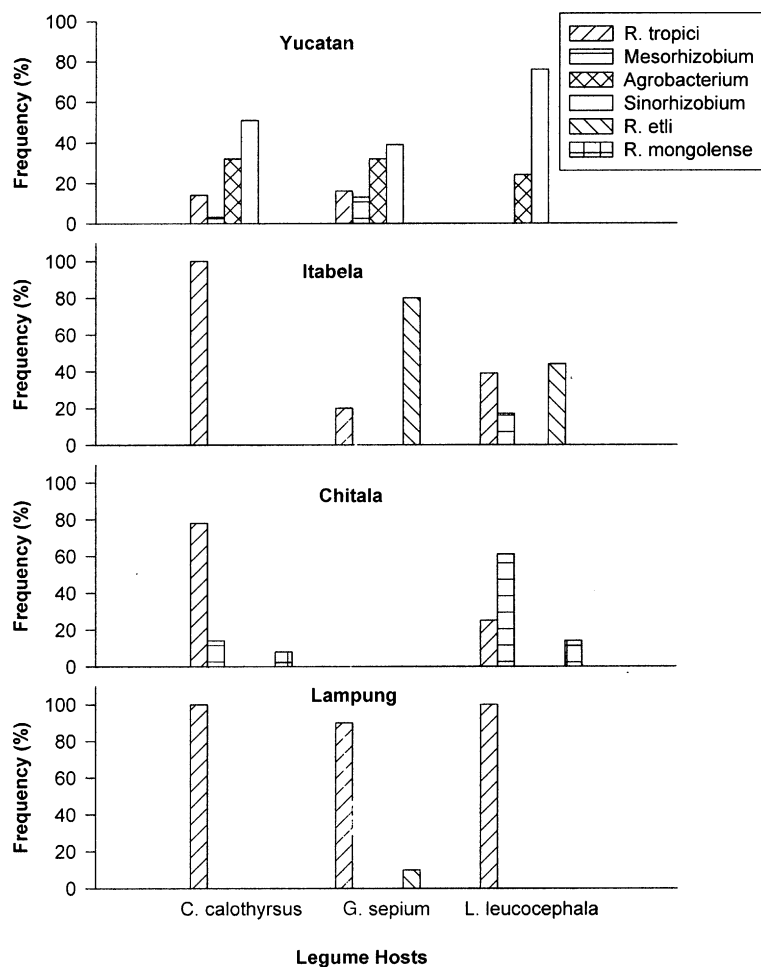

Figure 1. Distribution of rhizobial types that nodulated *C. calothyrsus*, *G. sepium* and *L. leucocephala* in different soils (Yucatan, Mexico; Itabela, Brazil; Chitala, Malawi; Lampung, Indonesia).

calothyrsus, only five were effective or very effective, with four being members of the *R. tropici* group. This group fixed an average of 5.9 mg N per plant compared with 4 mg N per plant fixed by the only *Sinorhizobium* spp. strain (GYB2-7). Nine of the thirty strains inoculated on *G. sepium* were effective or very effective with seven of these belonging to the *R. tropici* group and fixing an average of 19.5 mg N per plant. This was the same amount of N fixed on *G. sepium* by the only *Sinorhizobium* strain CYB3-5, but not as much as those of the best three strains of the *R. tropici* group. Eleven of the twenty five strains inoculated on *L. leucocephala* were effective or very effective, six of which were of the *R. tropici* group and four of *Sinorhizobium* spp. The most effective strain on *L. leucocephala* was GYB4-A7, a *Sinorhizobium*

strain, fixing about 13 mg N per plant, with a group average of 9.2 mg N per plant. The *R. tropici* group fixed an average of 8.5 mg N per plant. The most effective strain on *S. sesban* was the *R. tropici* strain GCT2, fixing about 12.2 mg N per plant. On the average, however, the *Mesorhizobium* spp. fixed 10.4 mg N per plant compared with 9.4 mg N per plant fixed by members of the *R. tropici* group.

Characterisation of rhizobia based on phenotype

The grouping of rhizobia using 40 phenotypic characters yielded 12 clusters (Figure 4 and Table 2). Clusters I, II, V, VIII, X and XII consisted of homogenous rhizobia types, while

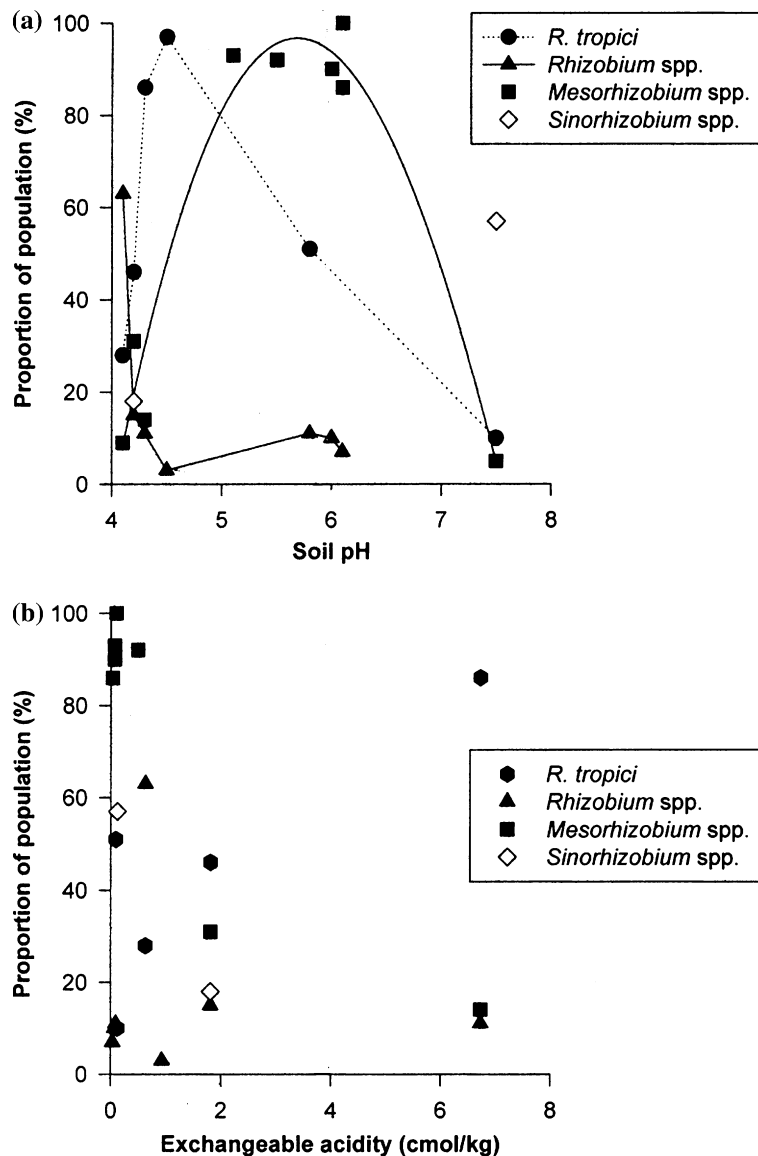

Figure 2. Relationships between the relative dominance of rhizobial types and (a) soil pH and (b) exchangeable acidity.

Clusters VI and VII were made up of single isolates. The four remaining clusters were comprised of mixtures of rhizobia sub-groups. Clusters I and II consisted of five and four isolates, respectively, which were closely related to *R. tropici*–*R. leguminosarum* lineage. Cluster III had 25 isolates, 22 of which were of the *R. tropici*–*R. leguminosarum* sub-types. Two other strains, including the type strain H152, were of the *R. giardinii* lineage, while the other was a reference strain for the *Sinorhizobium* branch. Cluster IV had five isolates of which two each were of the *R. tropici*–*R. leguminosarum*

and *R. mongolense*–*R. gallicum* branches, with the fifth isolate being of *Agrobacterium* lineage. All the five isolates in Cluster V and the six in Cluster VIII were of the *Mesorhizobium* branch. Clusters VI and VII had single isolates of *R. mongolense*–*R. gallicum* and *Mesorhizobium* lineages, respectively. Cluster IX was made up of *Mesorhizobium* and *Sinorhizobium* strains, while Clusters X and XII had *Mesorhizobium* and *Agrobacterium* types, respectively. Cluster XI was the most heterogeneous, consisting of five sub-groups of *Rhizobium* and *Sinorhizobium*. The *Rhizobium* spp. sub-group

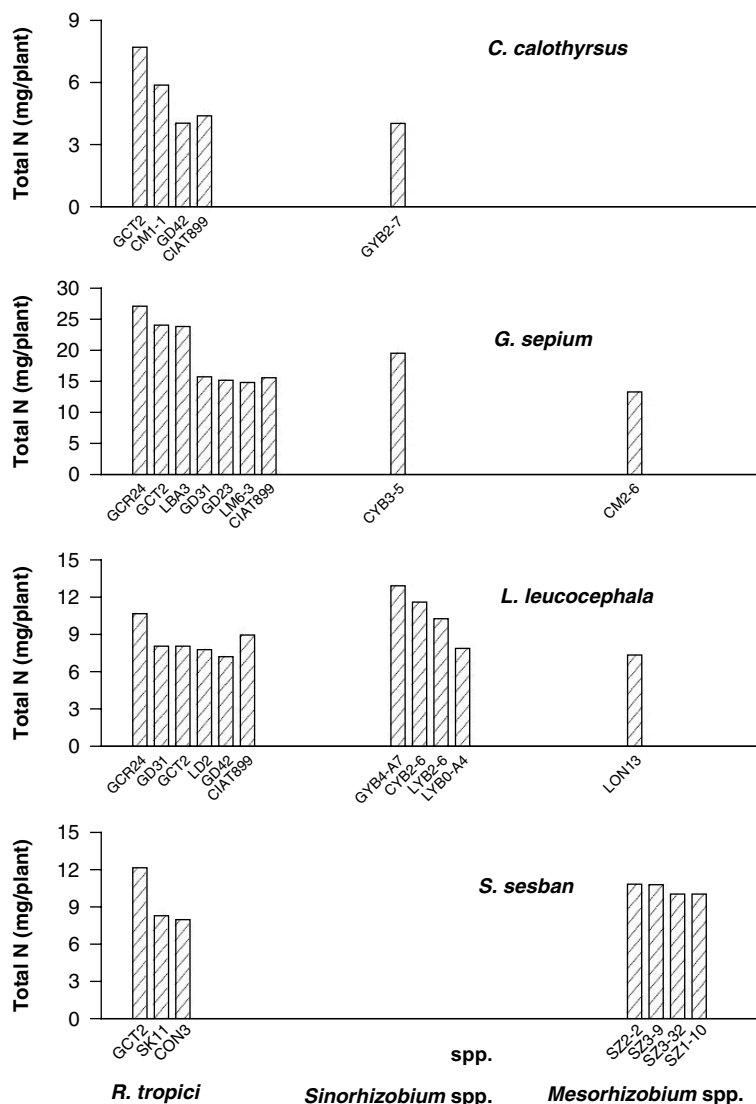

Figure 3. N₂ fixing effectiveness of different rhizobial types on host legumes.

in this cluster consisted of the reference strains for *M. loti*, *R. etli*, *R. gallicum* and *R. leguminosarum* bv. *phaseoli* and two isolates of the *R. tropici*-*R. leguminosarum* branch.

Seventeen carbon and one nitrogen compounds showed different degrees of discrimination in differentiating the various groups of rhizobia (Table 2). The *R. tropici*-type strains in the various clusters were differentiated by the ability, or otherwise, to grow on sucrose, dulcitol, maltose, PEG, cyclodextrin, tartarate, oxalate, acetate, starch and tyrosine. The *Mesorhizobium* sub-types differed in their utilisation of all the 17 substrates other than dulcitol, on which they all failed to

grow, and tartarate, which they all utilised. The differentiating compounds among the *Sinorhizobium* sub-groups were arabinose, fucose, PEG, tartarate, citrate, acetate and starch. The *Sinorhizobium* all failed to utilise dulcitol, cyclodextrin and oxalate. The two *R. mongolense*-*R. gallicum* sub-types in Clusters VI and XI differed in their ability to grow on sucrose, lactose, arabinose, PEG and starch. Both groups failed to utilise fucose, succinate, cyclodextrin, tartarate, oxalate and acetate. The *Agrobacterium*-like strains in Cluster XII were only able to utilise dulcitol, arabinose, fucose, succinate, maltose and tyrosine.

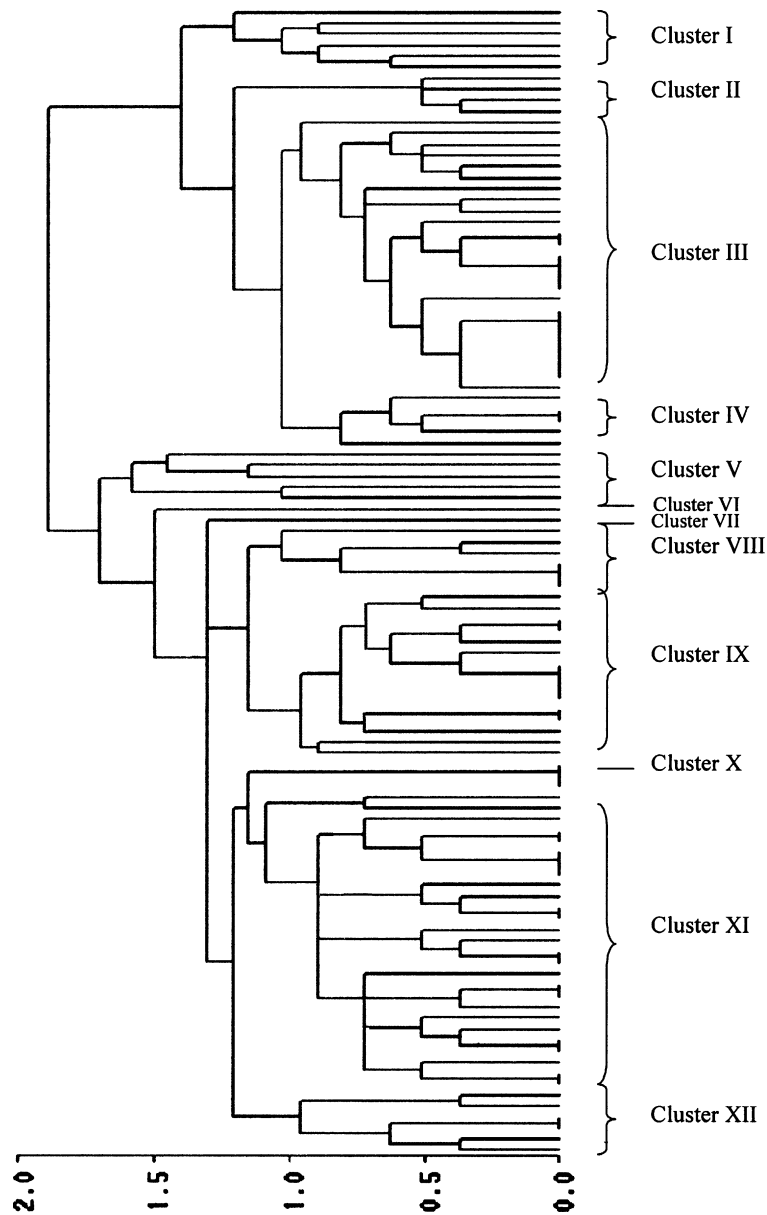

Figure 4. Differentiation into phenetic clusters of tree rhizobia isolated from thirteen soils across three continents in the tropics. The dendrogram was created from cluster analysis based on matrix and Euclidean distance using forty phenotypic traits.

Discussion

Legume nodulation in relation to diversity of rhizobia

Nodulation and N_2 -fixation by legumes occur only in the presence of compatible rhizobia. The complete dominance of the *R. tropici*-type rhizobia in

the Lampung soil suggests that the presence of just one compatible rhizobial type is sufficient for this function to be carried out. However, diversity in rhizobial types within a population could ensure the resilience of the population to environmental stress or disturbance as appears to be the case for other organisms (Giller et al. 1997). Therefore, the rhizobial population in the Yucatan soil, which

had greater rhizobial diversity, could be expected to be more resilient when faced with an environmental stress or disturbance.

Rhizobia are highly competent, heterotrophic organisms that can survive as large populations for decades in the absence of host legumes (Giller 2001), but the presence of a compatible host legume confers protection to the microsymbionts against environmental stresses (Andrade et al. 2002). On the other hand, a greater diversity of rhizobia in soil populations broadens the range of legume hosts that can be nodulated in such soils. There is thus a mutual benefit between above-ground (legume) and belowground (rhizobia) biodiversity.

There are indications that the rhizobia infecting legumes in areas outside the hosts' centre of diversity may be symbionts of local legumes, which can also infect the introduced species (Martínez-Romero and Caballero-Mellado 1996; Bala et al. 2003b). Thus promiscuity in host range appears to be the norm for tropical legumes and rhizobia (Giller 2001). This attribute seems to be driven by the huge diversity of rhizobial types in tropical soils. Contrary to the concept of a homogenous and promiscuous group of rhizobia of the 'cowpea miscellany' in tropical soils (Singleton et al. 1992), recent studies have shown that tropical rhizobia are diverse with sub-groups of varied symbiotic specificity and effectiveness (Thies et al. 1991; Mpeperekki et al. 1996). This was further supported by our result, which showed rhizobia of the same phylogenetic grouping nodulating *C. calothyrsus*, *G. sepium* and *L. leucocephala* in some soils, but failing to nodulate at least one of the hosts in other soils (Figure 1), thus suggesting that rhizobial phylogeny and host range (infectiveness) are only weakly linked.

Symbiotic effectiveness in relation to rhizobial biodiversity

In spite of the relatively large numbers of rhizobial strains that nodulated host legumes and the high degree of genetic diversity amongst these strains (Bala et al. 2003b), only a small fraction was symbiotically effective on their hosts (Figure 3). Thus the relative permissiveness of the hosts may not guarantee effectiveness in N₂-fixation and may actually lead to the formation of ineffective nod-

ules when infected by some competitive strains, which are not highly evolved to fix N₂ with these legumes (Andrade et al. 2002). A balance is, therefore, necessary between the need for diversity of gene pools and the presence of effective microsymbionts for any given legume host.

The predominance of *R. tropici*-type rhizobia among the most effective strains on the host legumes was no surprise since *R. tropici* was reported as having a broad host range (Martínez-Romero et al. 1991) and the *R. tropici* strain CIAT899 is often used as an inoculant strain for these legumes. In spite of such dominance, other rhizobial types were at least as effective as the *R. tropici*-types in N₂-fixation. The fact that sinorhizobia, rather than the *R. tropici* types were the most effective on *L. leucocephala* appeared to be a reflection of the long-term co-existence of the sinorhizobia and the host in the Yucatan soil (originally from Mexico) from which the sinorhizobia strains were all isolated. Wang et al. (1999) found that *L. leucocephala* is predominantly nodulated by sinorhizobia in soils of Central Mexico. Thus environmental influences, rather than rhizobial phylogeny, may be more important in determining symbiotic effectiveness. It is pertinent that many of the isolates tested on the hosts were more effective than CIAT899, suggesting that strains with better performance than CIAT899 readily may be found.

Ecology of rhizobial types

There appeared to be an apparent effect of soil pH and exchangeable acidity on the relative dominance of rhizobial types. The dominance of *R. tropici*-type rhizobia at low pH agrees with previous reports that showed this species to be the best adapted to acidic conditions (Graham et al. 1994). Earlier studies of rhizobial populations from two Kenyan soils indicated a dominance of *R. tropici* strains in an acid soil with high aluminium-saturation, whereas *R. etli* strains were dominant in a soil with near-neutral pH (Anyango et al. 1995). *R. tropici* was also the most competitive for nodulation in acid soil conditions while *R. leguminosarum* competed better in alkaline soil (Anyango et al. 1998). In a recent study of rhizobial populations in Brazil, however, *R. leguminosarum* strains dominated in

Table 2. Differentiation of rhizobial genetic groups based on substrate utilisation.

	Glu ^a	Suc	Lac	Dul	D-Arab	Fuc	Sut	Mal	PEG	Man	Cyc	Cel	Tar	Oxa	Cit	Ace	Sta	Tyr
Cluster I																		
<i>R. tropici</i> (6) ^b	+ ^c	-	1	3	+	+	+	-	+	+	+	+	+	4	+	+	+	-
Cluster II																		
<i>R. tropici</i> (4)	+	+	+	-	+	+	+	+	+	+	+	+	+	+	+	+	+	+
Cluster III																		
<i>R. tropici</i> (25)	+	+	+	+	+	+	+	+	+	+	+	+	+	24	+	11	+	+
Cluster IV																		
<i>Rhizobium</i> spp. (5)	+	+	+	4	+	4	+	+	+	+	+	+	+	1	+	+	+	+
Cluster V																		
<i>Mesorhizobium</i> spp. (5)	-	-	1	-	-	-	2	-	-	3	-	-	+	-	-	1	-	2
Cluster VI																		
<i>R. mongolense</i> (1)	+	-	-	+	+	-	-	+	-	-	+	+	+	+	+	-	+	+
Cluster VII																		
<i>Mesorhizobium</i> spp. (1)	+	+	-	-	+	+	-	+	-	-	+	-	+	+	+	-	+	+
Cluster VIII																		
<i>Mesorhizobium</i> spp. (6)	+	+	-	-	+	+	+	+	-	+	1	+	+	-	-	+	-	4
Cluster IX																		
<i>Mesorhizobium</i> spp. (12)	+	+	-	-	7	+	+	+	+	+	+	+	+	8	+	+	10	9
<i>Sinorhizobium</i> spp. (3)	+	+	2	-	-	2	+	+	+	+	-	+	+	-	+	+	+	+
Cluster X																		
<i>Mesorhizobium</i> spp. (3)	+	+	-	-	-	-	+	+	-	+	-	-	-	-	-	-	-	-
Cluster XI																		
<i>R. mongolense</i> (2)	+	+	+	+	-	-	-	+	+	+	-	+	-	-	+	-	+	+
<i>Rhizobium</i> spp. II (6)	+	+	+	+	+	+	+	+	-	+	-	+	3	-	+	-	-	+
<i>R. tropici</i> I (4)	+	+	+	-	+	+	+	+	+	+	+	+	+	-	-	-	2	+
<i>Sinorhizobium</i> spp. I (4)	+	+	3	-	+	-	+	+	-	+	-	+	-	-	-	-	-	+
<i>R. tropici</i> II (8)	+	+	+	4	+	+	+	+	-	+	-	+	-	-	+	+	-	+
<i>Sinorhizobium</i> spp. II (3)	+	+	+	-	-	+	+	+	-	+	-	+	-	-	-	+	-	+
Cluster XII																		
<i>Agrobacterium</i> spp. (6)	-	-	-	+	+	+	+	+	-	-	-	+	-	-	-	-	-	+

Number in parentheses represents the number of isolates for each rhizobial type.

^a Glu, Glucose; Suc, Sucrose; Lac, Lactose; Dul, Dulcitol; D-Arab, Arabinose (D-); Fuc, Fucose; Sut, Succinate; Mal, Maltose; PEG, Polyethylene glycol; Man, Mannose; Cyc, Cyclodextrin; Cel, Cellobiose; Tar, Tartarate; Oxa, Oxalate; Cit, Citrate; Ace, Acetate; Sta, Starch; Tyr, Tyrosine.

^b Genetic affiliation closest to *R. tropici* and *R. leguminosarum*.

^c +, all isolates were positive; -, all isolates failed to grow; Numbers are those of isolates that were positive.

the most acid soils with the highest aluminium saturation, whereas the abundance of *R. tropici* strains decreased with increasing aluminium stress (Andrade et al. 2002). Vargas and Graham (1989) also found no significant differences between the numbers of *R. tropici* strain CIAT899 and *R. leguminosarum* strain CIAT632 (supposedly acid-tolerant and acid-sensitive strains, respectively) in the rhizosphere of *Phaseolus vulgaris* at pH 4.5. These findings may explain the rather surprising result in our study, which showed that *Rhizobium* spp., consisting of close relatives of *R. etli*, and *R. giardinii*, were predominant over *R. tropici* types at soil pH below 4.2. Alternatively, the result could be attributed

to the large proportions of *R. etli* types in the Itabela soil, which was sampled from the Bahia region of Brazil. Although this soil had low pH, it also had relatively low exchange acidity, which could have enabled the *R. etli* types survive and dominate the population. *R. etli* is frequently adapted to acid soils, especially in South America where it forms effective symbiosis with several legumes including *Leucaena* species (Martínez-Romero et al. 1991).

The relative dominance of *Mesorhizobium* and *Sinorhizobium* species at intermediate and high pHs provides an interesting result that needs to be confirmed in further studies. The results, however, appear to be a reflection of the adaptation of these

rhizobia as most of the species in both genera were described using strains that originated from soils of intermediate to high pHs. The establishment of a relationship between rhizobial types and soil conditions, especially acidity, could have a significant impact on our ability to predict the adaptability of inoculant strains to specific soil types and conditions.

Phenotypic characterisation of rhizobia

The major phenotypic clusters formed were broadly consistent with genetic groupings based on 16S rRNA sequences, although variant strains were nested within some of the clusters. A comparison of substrate utilisation of strains provides some insight into the diversity of rhizobial types (Table 2). Reports show that *R. tropici* does not grow in dulcitol, in contrast to *R. leguminosarum*, *R. etli* and *R. gallicum* strains (Amarger et al. 1997). The ability of the two *R. mongolense*–*R. gallicum* sub-groups to grow on dulcitol was consistent with this result. However, only the *R. tropici* types in Cluster II and the *R. tropici* in Cluster XI failed to utilise dulcitol, indicating that the other *R. tropici*-like sub-groups may be *R. leguminosarum* or some other closely related strains. Among the *Mesorhizobium* species, *M. huakuii* does not use fucose (Jarvis et al. 1997); a similar characteristic was shown by the mesorhizobia in Clusters V and X. The phenotypic method of characterising rhizobia appears to have a potential to clearly differentiate rhizobia into homogenous groups; what is required is to use a particular number of differentiating characters that will achieve that objective. This, therefore, underlines the need to standardise the methodology and establish the set of characters required to unambiguously differentiate different rhizobial types.

Conclusions

Understanding the ecology of different rhizobial groups will further enhance our knowledge of rhizobia. This is especially poignant considering that the success of inoculation, particularly if inoculant strains are to establish in the soils, depends on the saprophytic competence of the

inoculant strain. Thus our ability to predict the environmental responses of rhizobial groups will bring a more practical meaning to rhizobial classification and diversity. The results of this study only showed a weak link between rhizobial phylogeny and function (in terms of nodulation and N₂-fixation). A better correlation appeared to exist between phylogeny and adaptation to soil acidity, although contrasting results from other studies tend to suggest that this link is tenuous. It would appear that diversity is more likely to be of major importance in stability of function by providing a diverse gene pool that imparts greater resilience to soil stresses. The broad correlation between rhizobial groupings based on chromosomal genes and those derived from phenotype suggests that a consistent and coherent rhizobial classification based on phenotypic characters may be possible with rigorous selection and evaluation of phenotypic characters. However, given the tenuous relationship between phylogeny on one hand, and nodulation and N₂-fixation on the other, it appears unlikely that the latter may eventually be part of the established set of phenotypes to be used for such a purpose. These results are largely empirical and will need confirmation through more research in this area.

References

- Amarger N., Macheret V. and Laguerre G. 1997. *Rhizobium gallicum* sp. nov. and *Rhizobium giardinii* sp. nov., from *Phaseolus vulgaris* nodules. Int. J. Syst. Bacteriol. 47: 996–1006.
- Anderson J.M. and Ingram J.S.I. 1993. Tropical Soil Biology and Fertility: A Handbook of Methods. CAB International, Wallingford, UK, 221pp.
- Andrade D.S., Murphy P.J. and Giller K.E. 2002. The diversity of *Phaseolus*-nodulating rhizobial populations is altered by liming of acid soils planted with *Phaseolus vulgaris* L. in Brazil. Appl. Environ. Microbiol. 68: 4025–4034.
- Anyango B., Wilson K.J., Beynon J.L. and Giller K.E. 1995. Diversity of rhizobia nodulating *Phaseolus vulgaris* L. in two Kenyan soils of contrasting pHs. Appl. Env. Microbiol. 61: 4016–4021.
- Anyango B., Wilson K.J. and Giller K.E. 1998. Competition in Kenyan soils between *Rhizobium leguminosarum* bv. *phaseoli* strain Kim5 and *R. tropici* strain CIAT899 using the *gusA* marker gene. Plant Soil 204: 69–78.
- Bala A. and Giller K.E. 2001. Symbiotic specificity of tropical tree rhizobia for host legumes. New Phytol. 149: 495–507.
- Bala A., Murphy P. and Giller K.E. 2001. Genetic diversity of rhizobia from natural populations varies with the soil dilution sampled. Soil Biol. Biochem. 33: 841–843.

- Bala A., Murphy P. and Giller K.E. 2002. Occurrence and genetic diversity of rhizobia nodulating *Sesbania sesban* in African soils. *Soil Biol. Biochem.* 34: 1759–1768.
- Bala A., Murphy P.J., Osunde A.O. and Giller K.E. 2003a. Nodulation of tree legumes and the ecology of their native rhizobial populations in tropical soils. *Appl. Soil Ecol.* 22: 211–223.
- Bala A., Murphy P.J. and Giller K.E. 2003b. Distribution and diversity of rhizobia nodulating agroforestry legumes in soils from three continents in the tropics. *Mol. Ecol.* 12: 917–930.
- Giller K.E. 2001. Nitrogen Fixation in Tropical Cropping Systems. 2nd edn. CAB International, Wallingford, UK, 423pp.
- Giller K.E., Beare M.H., Lavelle P., Izac A.-M.N. and Swift M.J. 1997. Agricultural intensification, soil biodiversity and ecosystem function. *Appl. Soil Ecol.* 6: 3–16.
- Graham P.H., Sadowsky M.J., Keyser H.H., Barnet M., Bradley R.S., Cooper J.E., De Ley D.J., Jarvis B.D.W., Roslycky E.B., Strijdom B.W. and Young J.P.W. 1991. Proposed minimal standards for the description of new genera and species of root- and stem-nodulating bacteria. *Int. J. Syst. Bacteriol.* 41: 582–587.
- Graham P.H., Draeger K.J., Ferrey M.L., Conroy M.J., Hammer B.E., Martínez E., Aarons S.R. and Quinto C. 1994. Acid pH tolerance in strains of *Rhizobium* and *Bradyrhizobium*, and initial studies on the basis for acid tolerance of *Rhizobium tropici* UMR1899. *Can. J. Microbiol.* 40: 198–207.
- Jarvis B.D.W., Van Berkum P., Chen W.X., Nour S.M., Fernandez M.P., Cleyet-Marel J.C. and Gillis M. 1997. Transfer of *Rhizobium loti*, *Rhizobium huakuii*, *Rhizobium ciceri*, *Rhizobium mediterraneum*, and *Rhizobium tianshanense* to *Mesorhizobium* gen. nov. *Int. J. Syst. Bacteriol.* 47: 895–898.
- Martínez-Romero E., Segovia L., Mercante F.M., Franco A.A., Graham P. and Pardo M.A. 1991. *Rhizobium tropici*: a novel species nodulating *Phaseolus vulgaris* L. beans and *Leucaena* sp. trees. *Int. J. Syst. Bacteriol.* 41: 417–426.
- Martínez-Romero E. and Caballero-Mellado J. 1996. *Rhizobium* phylogenies and bacterial genetic diversity. *Crit. Rev. Plant Sci.* 15: 113–140.
- Mpeperek S., Wollum A.G. and Makonese F. 1996. Diversity in symbiotic specificity of cowpea rhizobia indigenous to Zimbabwean soils. *Plant Soil.* 186: 167–171.
- Mpeperek S., Makonese S. and Wollum A.G. 1997. Physiological characterization of indigenous rhizobia nodulating *Vigna unguiculata* in Zimbabwean soils. *Symbiosis* 22: 275–292.
- Odee D.W., Sutherland J.M., Makatiani E.T., McInroy S.G. and Sprent J.I. 1997. Phenotypic characteristics and composition of rhizobia associated with woody legumes growing in diverse Kenyan conditions. *Plant Soil* 188: 65–75.
- Raven P.H. and Polhill R.M. 1981. Biogeography of the Leguminosae. In: Polhill R.M. and Raven P.H. (eds), in *Advances in Legume Systematics, Part 6*. Royal Botanic Garden, Kew, England.
- Singleton P.W., Bohlool B.B. and Nakao P.L. 1992. Legume rhizobia inoculation in the tropics: myths and realities. In: *Myths and Science of Soils in the Tropics*. ASA, SSSA Special Publication No. 29, Madison, WI, USA, pp. 135–155.
- Sprent J.I. 1994. Evolution and diversity in the legume-rhizobium symbiosis: chaos theory? *Plant Soil* 161: 1–10.
- Sprent J.I. 1995. Legume trees and shrubs in the tropics: N₂ fixation in perspective. *Soil Biol. Biochem.* 27: 401–407.
- Thies J.E., Singleton P.W. and Bohlool B.B. 1991. Sub-groups of the cowpea miscellany: symbiotic specificity within *Bradyrhizobium* spp. for *Vigna unguiculata*, *Phaseolus lunatus*, *Arachis hypogaea*, and *Macroptilium atropurpureum*. *Appl. Environ. Microbiol.* 57: 1540–1545.
- Vargas A.A.T. and Graham P.H. 1989. Cultivar and pH effects on competition for nodule sites between isolates of *Rhizobium* in beans. *Plant Soil* 117: 195–200.
- Vincent J.M. 1970. *A Manual for the Practical Study of Root-nodule Bacteria*. Blackwell, Oxford, UK, pp. 164
- Wang E.T., Martínez-Romero J. and Martínez-Romero E. 1999. Genetic diversity of rhizobia from *Leucaena leucocephala* nodules in Mexican soils. *Mol. Ecol.* 8: 711–724.

Limestone, Minjingu Phosphate Rock and Green Manure Application on Improvement of Acid Soils in Rwanda

Nabahungu N.L.¹, Semoka J.M.R.² and Zaongo C.^{†3}

¹ISAR-Rwanda, B.P 138 Butare, Rwanda, ²Sokoine University, P.O Box 3151, Tanzania, ^{†3}ICRAF-Rwanda (late)
Correspondence author: Nabahungu Nsharwasi Léon: email: nabahungu@yahoo.com

Abstract

A study was conducted to assess the effects of limestone, Minjingu Phosphate Rock (MPR) and green manures (GMs) on maize yield, soil properties and nutrient uptake. 13 treatments were tested namely an absolute control, recommended rate of NPK and burned lime, NP and limestone, combinations of any two of the following materials: limestone, MPR, tithonia GM, tephrosia GM, and combinations of three of these amendments. Soil analysis at the beginning of the experiment revealed that the soil was deficient in N, P, and K, had low levels of Ca and Mg and toxic levels of exchangeable Al. Application of GMs improved the supply of N and K appreciably while limestone played a great role in reducing exchangeable Al. A significant contribution of P was from MPR. A combination of MPR, GMs and limestone supplied ample amounts of N, P, K, Ca, Mg and reduced exchangeable Al and hence resulted into high yield. In general tithonia application gave higher yields than tephrosia. These results were consistent with the higher quality of tithonia biomass relative to tephrosia biomass. The green manures in combination with MPR increased P uptake significantly. Nutrient concentration data indicated serious deficiencies of P, K and N consistent with soil analysis data but Ca and Mg were in the sufficiency range. Furthermore, the results indicated that using a combination of limestone, MPR and GMs is the best strategy in improving acid soils in Tonga, Rwanda

Key words: Aluminium toxicity, dolomite, tithonia, tephrosia

Introduction

Toxicity of aluminium (Al), iron (Fe), manganese (Mn) and hydrogen (H⁺) and deficiencies of calcium (Ca), magnesium (Mg), potassium (K) and phosphorus (P) are the fundamental biophysical causes for the declining per capita food production in many parts of the world, especially in acid soils of sub-Saharan Africa (Jackson, 1967). In many acid soils (pH < 4.5), however, exchangeable Al is the major cation occupying a significant proportion of the effective cation exchange capacity (CEC) (Kamprath, 1970).

It is increasingly being recognized that although acid soils in Rwanda occupy approximately 45% of the total arable land, 60% of the highland areas are covered by acid soils with pH less than 5.5 (Beenart, 1999).

Plant growth and production in these soils is limited by increasing depletion of nitrogen (N), P, Ca and Mg, high P adsorption (1,500 to 3,000 mg kg⁻¹ of soil), low permanent charge (−0.5 to −2.45 cmol (+) kg⁻¹) and Al toxicity (Mutwewingabo, 1989).

Application of lime has been shown to reduce Al toxicity, improve pH, Ca, Mg and increase both P uptake in high P fixing soil and plant rooting system (Black, 1993). As exemplified by Beenart (1999), application of 2 tons ha⁻¹ of burned lime together with 300 kg NPK (17%:17%:17%) ha⁻¹ resulted in maize yield of 5 t ha⁻¹. Due to the high prices of burned lime and its negative impact on environment, the use of low cost and locally available ground unburned liming materials alone or in combination with organic fertilizers, seems to be a practical option.

There is increasing evidence that green manuring, intercropping or crop rotation, alley and contour farming (Nnadi and Haque, 1988) and improved fallow technologies (Balasubramanian and Sekayange, 1992) can restore soil fertility (i.e. increase N, P and K availability for plant uptake) and maximize agricultural crop production by the resource poor farmers in Rwanda. In addition to these benefits of organic inputs, the decomposition of organic materials are known to ameliorate heavy metal toxicities (e.g. Al and Mn) through complexation reactions by the organic acids and other by-products released in the process (Zaharah and Bah, 1999). Since for better plant growth 800 kg ha⁻¹ of P are required to maintain an optimum P concentration of 0.2 mg kg⁻¹ soil in the acid soil solution in Rwanda, the use of organic N and locally available phosphate rocks (PR) and inorganic P fertilisers (Juo and Fox, 1977; Mutwewingabo, 1989) may give a good solution for low crop yields in the acid soils of Rwanda.

Although PR application has shown tremendous potential in improving crop yield and soils properties in acid soils (Chien et al., 1980) evidence exist to show that short-term crops may not always benefit from these P-sources due to their relatively low reactivity (Zaharah and Bah, 1977). This, therefore, implies that adequate attention needs to be paid on the type of PR to be used. Variable results on reactivity of PR can be attributed to differences in their P composition, solubility and suitability as sources of P. The Minjingu phosphate rock (MPR) from Tanzania and Busumbu phosphate rock from Uganda are among the most suitable sources of P (Van Straaten, 1997). Sustainable food crop production in smallholder farmers can, however, be achieved through proper use of MPR (Buresh et al., 1997) or other PR, limestone and organic fertilisers (Clark et al., 1993; Baligar et al., 1997).

Application of green manure to the soil supplied with P has been reported to increase the amount of P released in soil solution and its efficiency by agricultural crops (Nziguheba et al., 1998). The positive effect of mixing soil amendments, such as organic N sources, e.g. farm-yard manure and composts, with PRs is widely reported (Yang et al., 1994; Gachengo et al., 1999). It is worth noting, however, that the amount of P from PR taken up by plants and crop yield depend on the extent of PR dissolution, P-soil interactions and type of crop.

Although it is increasingly recognised that limestone, MPR and green manures such as *Tithonia diversifolia* (tithonia) and *Tephrosia vogelii* (tephrosia), which are widespread in Rwanda are of low cost and safe (Beenart, 1999), very little is known about the

effectiveness of tithonia and tephrosia manures in regulating P release and uptake from MPR and lime added to acidic soils of Rwanda. The general objective of the present study, therefore, was to investigate the interactive effects of limestone, tithonia/tephrosia green manures on soil fertility and maize yield in Rwanda.

Materials and methods

Field experiment was conduct on Gleyic-Alumic Ferralsol (Hyper dystic) (FAO, 1999). Characteristics of the soil in the top 20 cm were as following: The textural class is sandy clay loam, pH in water = 4.7, exchangeable acidity = 4.1 cmol (+)/kg, CEC = 5.2 cmol (+)/kg, exchangeable Ca=0.8 cmol (+)/kg, exchangeable Mg = 0.2 cmol (+)/kg, exchangeable K = 0.09 cmol (+)/kg, organic C = 2.0%, Bray 1 P= 5 mg/kg. The test crop was maize variety ZM 607. Fertilisers used were: unburned ground travertine, unburned ground dolomite (CaMgCO₃), Minjingu phosphate rock (MPR), green manure from tephrosia and tithonia. Unburned travertine rock was collected from Ruhengeri (North-east of Rwanda) while dolomite rock was collected from Kibuye (North-west of Rwanda). They were ground to pass through 1 mm sieve and mixed in 1:1 ratio (i.e. 50% travertine mixed with 50% dolomite). The Minjingu phosphate rock was collected from Minjingu Phosphate mine, Arusha, Tanzania. The chemical characteristics of MPR, liming materials and TSP are summarised in Table 1.

A field experiment was conducted at Tonga cell in Butare region, Rwanda. The experimental site is located at 2°35'S and 29°43'E at an altitude of 1 734 m.a.s.l. Butare region has bimodal rainfall pattern. For the treatment with the currently recommended fertilizer rate, burned lime and commercial NPK were used;

Table 1. Initial chemical properties of the experimental materials (MPR, the mixture of travertine and dolomite and TSP)

Chemical properties	Experimental materials			
	MPR	Travertine + Dolomite	Burned lime	TSP
Total P (%)	12.8	0.05	—	20
NAC ¹ P(%)	2.5	—	—	—
Calcium (Ca) (%)	32.9	28.0	47.5	13
Magnesium (Mg) (%)	2.2	14.5	10	—
Potassium (K) (%)	1.0	0.6	1.3	—

¹Neutral ammonium citrate

Table 2. Description of treatment combination used

Treatments	Amount of nutrient added per hectare
Control	—
MPR	100 kg P
Limestone	2,377 kg
Tithonia green manure	5 t
Tephrosia green manure	5 t
Tephrosia + MPR	5 t+ 100 kg P
Tithonia +MPR	5 t + 100 kg P
Tithonia + Limestone	5 t +2,377 kg
Tephrosia + Limestone	5 t +2,377 kg
N, P as Urea and TSP, respectively+Limestone	175kg N, 100 kg P + 2 377 kg
Tithonia + Limestone +MPR	5 t +2,377 kg+ 100 kg P
Tephrosia + Limestone +MPR	5 t ha ⁻¹ +2,377 kg + 100 kg P
Recommended rate of N, P, K and burned Lime.	50 kg N, 22.5 kg P, 42.5 kg K and 2 t lime

The source of N, P and K was a compound fertilizer with a grade of 17% N, 17% P₂O₅ and 17% K₂O.

for the other treatments the rates of organic or inorganic fertilisers were calculated as follows: (i) Rates of lime (mixture of travertine and dolomite) were calculated by Kamprath method (1.5 cmol (+) of CaCO₃ neutralising 1 cmol (+) kg⁻¹ exchangeable Al). In this experiment, an amount equal to a half of that required for neutralizing exchangeable Al was used for all treatments. Exchangeable Al in the experimental soil was 3.4 cmol (+) kg⁻¹ and half of the amount required to neutralize this level of exchangeable Al is 2,377 kg lime ha⁻¹, (ii) The rate of green manures was 5 t ha⁻¹. Phosphorus from MPR and TSP was applied at the rate of 100 kg ha⁻¹. A total of 13 treatments as listed Table 1 were tested and these were arranged in a completely randomised block design with three replications.

Two seeds were sown per hole at a spacing of 50 cm × 60 cm. Sowing was done two weeks after liming, green manuring and fertilizer application. Seedlings were then thinned to one plant per hill two weeks after emergence giving a plant population of 42,000 ha⁻¹. Inter-plot and inter-block spacing were one meter and two meters, respectively.

For the estimation of nutrient concentration in maize plants, fifteen leaves were sampled randomly from each plot at approximately 50% tasselling stage. Maize was harvested after 150 days of growth. A guard row was left around each plot so that only the inner 5 rows were harvested. Cobs were harvested and shelled and the grains were sun dried, winnowed and weighed. Grain yield was calculated at 13% moisture content and reported in kg ha⁻¹. Ten sub samples were collected

randomly from each plot to a depth of 20 cm after harvesting.

Laboratory analysis

Particle size analysis was done by the hydrometer method (Gee and Bauder, 1986), and textural classes were determined using the USDA textural class triangle. Soil pH was determined using a pH meter in 1:2.5 soil: water and KCl suspensions (Page et al., 1982). Cation exchangeable capacity was determined by the ammonium acetate saturation method (Rhoades, 1982). Exchangeable Ca and Mg in the ammonium acetate leachate were determined by atomic absorption spectrophotometer. Exchangeable K was determined by using a flame spectrophotometer and Al + H was determined by atomic absorption spectrophotometry. Organic carbon was determined by the Walkley and Black method (Page et al., 1982). Total N was determined by semi-micro Kjeldahl procedure (Page et al., 1982). Available P was extracted by Bray1 method (Page et al., 1982) and determined colorimetrically using the ascorbic acid method (IITA, 1979).

Plant materials was digested in a mixture of HNO₃ and H₂O₂ as outlined by Jones and Case (1990) and modified by Moberg (2000). The content of P in the digest was determined using the ascorbic acid-molybdate blue method. Ca, Mg, Zn and Cu from the digests were determined by atomic absorption spectrophotometry while K concentration was determined

by flame spectrophotometry. Analysis of total N was determined by semi-micro Kjeldahl procedure (Page et al., 1982).

Data processing

Analysis of variance (ANOVA) was done and means were compared using Duncan's Multiple Range Test (DMRT).

Results and discussion

Effect of limestone, MPR and GM on yield and soil properties

The effects of lime, MPR and green manures on yield are presented in Table 3 while selected soil properties of soil samples taken from experimental plots are presented in Table 4.

Effect of limestone, MPR and GM on maize yield

Limestone alone increased the yield by 13.5 times compared to the control while the NPL (Nitrogen as urea source, P from TSP and burned lime) treatment increased yield by 8.9 times (Table 3). The MPR alone significantly increased maize yield compared to the check, NPL, tephrosia and limestone alone by 2107%,

Table 3. Effect of limestone, MPR and GM on maize yield

Treatments	Yield (kg ha ⁻¹)
Control	148j
MPR	3,267g
Limestone	1,996h
Tithonia	3,349g
Tephrosia	1,452i
Tephrosia + MPR	3,993e
Tithonia + MPR	4,554c
Tithonia+Limestone	3,762f
Tephrosia+Limestone	4,323d
NPL	1,468i
Tithonia+Limestone+PR	5,594b
Tephrosia+Limestone+PR	5,907a
NPKL	4,240d
CV %	11.1

Means in the same column followed by the same letter(s) are not significantly different according to Duncan Multiple Range Test at 0.05 levels.

122.5%, 125% and 63.7%, respectively. The yield of recommended fertilizer combination (NPKL) was higher than NPL, MPR alone, limestone alone, tithonia alone, tephrosia alone, tephrosia + MPR and tithonia + limestone by 277.2%, 29.8%, 112.4%, 26.6%, 192.05, 6% and 12.7%, respectively. The yield of tithonia treatment was 22.7 times that of the check treatment and 231% of the tephrosia treatment while for

Table 4. Selected chemical properties of soils from experimental plots after maize harvest as influenced by limestone, MPR and GM

	pHw	KClpH	Al	Ca → cmol (+)/kg ←	Mg	K	Bray1 P mg/kg
Control	4.9h	3.87e	3.0a	0.67f	0.23d	0.07i	3.0h
MPR	5.2fg	4.07d	2.2d	1.2cde	0.47cd	0.07i	17.7a
Limestone	5.6abc	4.20bc	1.4fg	1.7b	1.0ab	0.08h	6.0gf
Tithonia	5.1g	3.93e	2.4cd	0.8ef	0.43cd	0.13c	8.5e
Tephrosia	5.1g	3.93e	2.9ab	0.9def	0.57cd	0.13c	5.7fg
Tephrosia + MPR	5.3ef	4.13dc	2.6bcd	1.3c	0.60c	0.13b	14.4b
Tith. + MPR	5.3ef	4.10d	2.7abc	1.2cd	0.43cd	0.15a	10.7c
Tithonia+Limestone	5.7ab	4.37ab	1.4fg	1.7b	0.93b	0.10f	5.1g
Tephrosia+Limestone	5.6bc	4.43a	1.4fg	2.1a	1.00ab	0.10g	5.0g
NPL	5.4ed	4.27b	1.9e	2.0ab	1.00ab	0.03j	10.4cd
Tith+Limestone+PR	5.7ab	4.37ab	1.4fg	1.9ab	1.20ab	0.13b	7.2ef
Tephrosia+Limestone+PR	5.8a	4.37ab	1.3g	2.1a	1.33a	0.12d	8.9de
NPKL	5.5cd	4.27b	1.7ef	1.8ab	0.33cd	0.11e	7.1ef
CV %	1.6	1.7	9.3	13.2	25.1	6.2	11.9

Means in the same column followed by the same letter(s) are not significantly different according to Duncan Multiple Range Test at 0.05 level of significance

the tithonia plus MPR, yield was 114% of tephrosia + MPR. Tephrosia alone increased yield by 9.8 times compared to the check treatment but the yield was still low compared to other treatments. The combination of limestone and tithonia had higher yield than limestone alone and tithonia alone. The yield of tithonia + limestone treatment was 188.5% of that of limestone alone and 112% of that of Tithonia alone.

On the other hand tephrosia + limestone had higher yield than either limestone alone or tephrosia alone. The combination of the three amendments improved yield even further with tephrosia + limestone + MPR having the highest (5907 kg ha⁻¹) followed by tithonia + limestone + MPR (5594 kg ha⁻¹).

The high yield associated with MPR alone may be due to improvement in P supply in this soil, which had very low P status. Also MPR supplied Ca and reduced soil acidity slightly while limestone could have reduced Al toxicity and supplied Ca and Mg and hence favoured good growth. The high yield associated with tithonia GM may be due to higher contents of P, N and K and faster release of the nutrients from tithonia than from tephrosia. The short-term immobilisation of P and slower provision of N and K resulting from application of the lower quality tephrosia, could have negatively affected the early growth of maize in the treatment with tephrosia alone. The high yield of the combination of three amendments was more likely due to a higher supply of N, P and K and better root growth due to elimination/decrease of Al toxicity.

The small response to N and P from inorganic fertilizers cannot easily be explained given that N and P were applied at the same rate for organic inputs. One possibility is that since K is limiting in this soil (Table 4) the application of lime and high rate of N might have aggravated the K problem. This explanation is supported to some degree by the high response to inorganic N and P when the K was not a limiting factor (Jama et al., 2000) as well as the NPKL treatment in this study. These yields with organic inputs illustrate the difficulty in interpreting such data because organic matter adds several nutrients and the amount; ratio and release of nutrients added from the different organic materials vary (Palm et al., 1997). It is therefore difficult to relate differences in yield to one nutrient alone unless all other nutrients are added in adequate quantities. The fact that crop growth in this study was limited by many nutrients (N, P, K, Ca and Mg and micronutrients) also makes it difficult to compare yields and nutrient uptake from the organic treatments that supply many nutrients

at the same time compared to NPL treatment. Organic matter amendments improve soil physical properties, which can account to improved yield comparative to inorganic fertilizers.

The high yields from the treatments with three amendments could be explained by the alleviation of many constraints at the same time such as decrease of Al toxicity and increase in P, K, N, Ca and Mg supply. In addition the application of limestone might have improved root growth and distribution in soil. The greater root growth may have led to increased uptake of P and other nutrients.

Effect of limestone, MPR and GM on field soil properties

The results for residual soil nutrients given in Table 4 indicate that after harvesting, the properties of the soil were improved in all treatments compared to the control but in general their levels were still low. The Bray1 P in the soil treated with either MPR or TSP was low; indeed in the control the phosphorus is very low (<3 mg kg⁻¹).

Plots treated with either MPR alone or combinations of GMs and MPR gave higher Bray1 P than those treated with MPR mixed with GMs and limestone. Addition to the soil of MPR and MPR-GMs mixtures on average increased Bray 1 P from 3.0 to 14.3 mg kg⁻¹ and total P from 214.0 to 331.5 mg kg⁻¹ representing increases of 376.7% and 54.9%, respectively. MPR-green manure application also increased Bray 1 P and total P by 116.7% (from 6.6 to 14.3) and 6.7% (from 310.7 to 331.5%) as compared with MPR-green manure-lime treatments, respectively.

This was probably due to the effect of CaCO₃ on the dissolution of MPR. Low pH, low exchangeable Ca and low P are the major soil factors known to increase dissolution and subsequent P release from PRs (Smith and Sanchez, 1982). Addition of CaCO₃ increased soil pH and exchangeable Ca. This may account for the low available P, presumably through a decrease in the availability of protons and a decrease in the size of the calcium sink in the soil (Hanafi et al., 1992). MPR addition slightly increased soil pH, which probably resulted from the consumption of protons during the PR dissolution or through neutralisation of soil acidity by accessory carbonates in the PR. The application of both travertine and dolomite increased exchangeable Ca and Mg.

The exchangeable Ca and Mg is another factor responsible for the decrease in the dissolution of the PR

material. This observation is in agreement with the findings of He et al. (1996) on dissolution of North Carolina PR. Dissolution of the PR is increased by the removal of Ca and H_2PO_4^- from the soil solution, provided the pH is sufficiently low (Robinson and Syers, 1990).

Application of limestone alone increased Bray 1 P by 100% relative to the control. These results are similar to those of Martini et al. (1974) who observed a reduction in fixation of added P fertilizer with liming. Roberston et al. (1954) found that liming soils high in sesquioxides increased P availability, whereas liming soils low in sesquioxides had no effect on P availability. The experimental soil was highly weathered, therefore, might have high sesquioxides. On the other hand, other studies have failed to show increases in available P with liming (Mtenga, 2000).

The effects of limestone, MPR, GM and their combination on exchangeable K are given in Table 4. Plots where mineral K or organic fertilisers were not applied (plots treated with NPL, MPR and limestone) gave lower K levels than others. Application of lime significantly decreased exchangeable K in the soil. The above observation concur with that of Curtin and Smillie (1995) that liming decreases exchangeable K. Mixing NPK with burned lime resulted in lower Mg as compared with that from other plots treated with limestone alone or a combination of limestone with MPR and/or green manure.

Liming has been shown to increase K retention, leading to K deficiency on freshly limed soils (Mtenga, 2000). This effect is thought to result from the opening up of selective exchange sites on soil colloids which were blocked by Al at low pH or from lowered percent K saturation caused by increased CEC. These reactions lead to a decrease in soil solution K and K uptake by plants, which may cause K deficiency (Magdoff and Bartlett, 1980).

Liming increased pH in water from 4.9 to a range of 5.6 to 5.8. Green manure, and MPR and their combination also increased pH slightly. MPR decreases soil acidity and increases pH because its dissolution consumes protons and substitutes the protons with Ca and Mg. Khasawneh and Doll (1978) and Sanyal and De Datta (1991) have reported similar effects with other PRs. Application of limestone alone or in combination with MPR and green manures, on average decreased total soil acidity by 55.9% (from 3.9 to 1.72) and increased exchangeable Ca from 0.67 to 1.9 cmol (+) kg^{-1} and Mg from 0.23 to 1.1 cmol (+) kg^{-1} . The Ca/Mg ratios were within 1 to 10 for all treatments. This range is considered optimum for crop growth.

Plots treated with MPR or MPR + green manures on average decreased exchangeable Al by 20% (from 3.0 to 2.5) relative to the control treatment. No significant effect of green manures alone on soil acidity properties relative to other amendments used was observed, but tithonia green manure decreased exchangeable Al by 25% relative to the control. However, there was no significant difference between exchangeable Al in the tephrosia treatment and the control.

Liming decreased exchangeable Al considerably to a level considered safe for most crops. The Al saturation decreased from 52% to 20%. Only very sensitive crops may be affected by this Al saturation level (20%) according to Landon (1995). Liming also increased exchangeable Ca and Mg. The relative increase in pH and decrease of Al toxicity on addition of green manures relative to the control may be attributed to self-liming effect due to the high concentration of cations in the green manures, which were released on mineralisation (Hue, 1992). Savini (1999) working with three fallow types found that tithonia fallows were associated with high soil cation (K, Ca and Mg) status and relatively higher pH than the other fallows. Since addition of green manures increases soil pH, the PR dissolution was reduced where green manures were applied in combination with PR. However, this increase in pH with green manures is important for P uptake (Table 4). Increasing pH will cause precipitation of exchangeable Al and Fe, thus reducing the potential for PO_4 precipitation. In acid soils, exchangeable acidity can react readily with PO_4 , reducing the availability of PO_4 for plant uptake. Thus, reduction of exchangeable acidity by soil amendments may be an important mechanism for reducing P sorption.

The reduction of exchangeable acidity by green manures in the soil may be explained partly by the concomitant increases in pH where green manures were applied (Table 4). This reduction may be caused by: precipitation of Al ions by OH ions released from exchange of ligands between organic anions and terminal hydroxyls of Fe and Al oxides, and/or complexation of Al by organic molecules (Hue, 1992). This agrees with the findings of Kamprath and Cyde (1970) that less Al in the soil solution accompanied the increase in organic matter content of soil at any given pH. This decrease in exchangeable acidity on addition of green manures reduces the number of sites available to adsorb P released from PR, which is another possible explanation for the increased P uptake in the treatments, which received MPR in combination with green manures (Table 4).

Table 4. Effects of limestone, MPR and GM on nutrient concentrations in maize leaves from the field experiment

Treatments	N	P	K	Ca	Mg
	(%)				
Control	2.20g	0.08g	0.24e	0.44e	0.26 d
MPR	2.63f	0.12d	0.42d	0.50e	0.33bcd
Limestone	2.53f	0.11e	0.45d	0.62d	0.42b
Tithonia	3.27dc	0.11e	0.72c	0.46e	0.29cd
Tephrosia	2.83e	0.10f	0.80cb	0.44e	0.27d
Tephrosia + MPR	3.33 c	0.14c	0.88ab	0.64cd	0.40bc
Tithonia + MPR	3.40bc	0.14c	0.99a	0.62d	0.44b
Tith. + Limestone	3.40bc	0.12d	0.66c	0.70bc	0.31cd
Tephr. + Limestone	3.13d	0.10f	0.70c	0.65bcd	0.39bc
NPL	3.40bc	0.22a	0.16e	0.84a	0.55a
Tith. + Lim. + MPR	3.60a	0.16b	0.68c	0.72b	0.26 d
Tephr. +Lim. + MPR	3.50ab	0.14c	0.79cb	0.72b	0.39bc
NPKL	2.83e	0.12d	0.78cb	0.64 cd	0.31bcd
CV %	3.36	10.4	12.9	5.8	16.4

Means in the same column followed by the same letter(s) are not significantly different according to Duncan Multiple Range Test at 0.05 levels.

Nutrient concentration in maize leaves

As illustrated in Table 4 application of limestone, MPR and GM (tithonia and tephrosia) significantly ($P < 0.05$) increased N, P, K, Ca and Mg. The data indicates that the most serious nutrient deficiencies in the absolute control treatment were P and K. The concentration of Ca and Mg in the control plants all fell in the sufficiency ranges according to Tandon (1995). Similar observations were found in results of the pot experiment. All the treatments significantly increased P concentration in leaves. The biggest increase occurred in the NPL treatment, which gave a concentration of 0.22%, which was close to the sufficiency level. Combination of green manures and MPR and GMs + Limestone + MPR treatments caused an intermediate increase in P with values ranging from 0.14%–0.16%. The high uptake of P from the combination of MPR and GM with or without limestone treatments might be due to the effect of the organic additions on P availability in soils.

The mixing of PR with limestone is thought to depress PR dissolution and plant P uptake and hence decrease yield. However, although Ca influences the dissolution of PR in the absence of plants, in the presence of plants the continuous uptake of Ca during the plant growth may have masked this effect. Saggar et al. (1993) observed the same effect when working with PRs in high P sorption soils. All the treatments significantly increased K concentration in leaves except

the NPL treatment, which significantly decreased K concentration in leaves. The biggest increase occurred in the combination of GMs and MPR treatment, which gave K concentration values ranging from 0.88–0.99%. However this range is still very low relative to the critical range published by Landon (1995). Green manures alone, NPKL and combination of GMs, limestone and MPR treatments resulted in intermediate increases in K with values ranging from 0.70%–0.80%.

The higher uptake of K from the combination of MPR and GM with or without limestone than from other treatments might be due to the effect of the organic additions on K availability in soils.

The negative influence of limestone on K uptake in the NPL treatment could be due to increased imbalance of K with Ca and/or Mg, which are higher in limed plots or a depression of K uptake by NH_4^+ . This treatment had also received high rate of inorganic N which might have enhanced the imbalance between NH_4^+ and K. Nitrogen concentration in leaves was increased significantly by all amendments used in the trial. The biggest increase occurred in the NPL, tithonia + MPR, tithonia + limestone and the combination of GMs, MPR and limestone treatments, which gave concentration values ranging from 3.4–3.6%, which was in the sufficiency level. Tephrosia, NPKL, tephrosia + limestone tephrosia + MPR treatments caused intermediate increases in N with values ranging from 2.83–3.33% which was close to the sufficiency level. Tithonia

green manures supplied more N to maize plants than tephrosia green manure. This observation supports the idea that the quality of organic inputs affects nutrient availability patterns and crop growth.

All the treatments significantly increased Ca and Mg concentration in leaves. The biggest Ca increase occurred in the NPL, combination of GMs and MPR and limestone, tephrosia + limestone and tithonia and limestone treatments, which gave concentration values ranging from 0.65–0.84%. Limestone alone, tithonia + MPR, tithonia + MPR and NPKL treatments caused intermediate increases in Ca with values ranging from 0.62–0.64%. While for Mg, the biggest increase occurred in the NPL, tithonia + MPR, tithonia, tephrosia + limestone and the combination of tephrosia, MPR and limestone treatments which gave concentration values ranging from 0.39–0.55%. The fact that Ca and Mg in the control plants fell in the sufficiency range indicates that the role of liming was mainly in decreasing Al toxicity rather than in correcting Ca and Mg deficiencies.

Although the exchangeable Ca and Mg were low in the soil in the control plot (Table 4), the concentrations of these nutrients fell in the critical range. This observation could be due to the low CEC and may also be due to the type of clay in the soil used. When CEC is low and the clay type is 1:1 (e.g. kaolinitic), available Ca and Mg in soil solution tend to be high compared to soils with high CEC and containing 2:1 clays e.g. montmorillonite.

Conclusions

This study demonstrated that there are many constraints to crop production in acid soils in Tonga. Some of the most serious problems are Al toxicity and P, K and N deficiencies, which were alleviated appreciably by a combination of amendments. Limestone application was found to reduce exchangeable Al, increase Ca and Mg status in soils and uptake of these nutrients. The addition of GMs to soil significantly increased exchangeable K in soil and plant uptake of N and K. The extent of the influence of GM was observed to be dependent on their quality. Tithonia GM was found to have high quality and provided N and K in quantities and rates relatively sufficient to increase crop yield substantially compared to tephrosia. High yield was obtained from the mixture of limestone, MPR

and GMs. The amendments provided substantial residual effects in both field and pot experiments. Limestone increased soil pH, exchangeable Ca and Mg, and decreased exchangeable Al. MPR increased extractable P while GMs contributed in increasing exchangeable K. Despite the increase in P and K concentrations in the experiment caused by the amendments, the concentrations were still below the critical range indicating that higher rates of the amendments were required.

Acknowledgements

We thank the ICRAF and the “Institut des Sciences Agronomiques ud Rwanda (ISAR)” for providing financial support. We also thank the technical staff at ISAR Rubona for the excellent field and laboratory work.

References

- Balasubramanian V. and Sekayange L. 1992. Five years of research on improved fallow in the semi-arid highlands of Rwanda. In: Mulongoy K., Guey M., Spencer D.S.C. (Eds) *Biological Fixation and Sustainability of Tropical Agriculture*. IITA, pp. 405–422.
- Baligar V., He Z.L., Martens D.C., Richey K.D. and Kamper W.D. 1997. Effect of phosphate rock, coal combustion by-product, lime, and cellulose on ryegrass in acidic soil. *Plant and Soil* 195: 129–136.
- Beenart F.R. 1999. Feasibility Study of Production of Lime and/or Ground Travertine for the Management of Acid Soils in Rwanda, Pro-Inter Project Consultants, Brussels: 250 pp.
- Black A.B. 1993. *Soil Fertility Evaluation and Control*. Lewis Publishers, Tokyo, London. 746pp.
- Buresh J.R., Smithson P.C. and Hellums D.T. 1997. Building soil phosphorus capital in Africa. In: *Replenishment Soil Fertility in Africa*. Soil Science Society of America, Special publication no 51: pp. 111–150.
- Chien S.H., Leon L.A. and Tejada H.R. 1980. Dissolution of North Carolina phosphate rock in acid Colombian soils as related to soil properties. *Soil Science Society of America Journal* 44: 1267–1271.
- Clark R.B., Ritchey K.D. and Baligar V.C. 1993. Dry matter yields of maize grown coal combustion by-products. In: *Proc. Int. Ash Util. Symp. Expo. 10th*. Vol 1. Orlando, Fl. American Coal Ash Association, Washington, DC, pp.1–11
- Curtin D. and Smillie G.W. 1995. Effects of incubation and pH on soil solution and exchange cation ratios. *Soil Science Society American Journal* 59: 1006–1011.
- FAO 1999. World Reference Base for Soil Resources. FAO. ISRIC and ISSS, Rome.
- Gachengo C.N., Palm C.A., Jama B. and Othieno C. 1999. Tithonia and senna green manures and inorganic fertilizers as phosphorus sources for maize in Western Kenya. *Agroforestry Systems* 44: 21–36.

- Gee G.W. and Bauder 1986. Particle size analysis. In: Klute A. (Ed), *Methods of Soil Analysis Part 1*. 2nd edn. Agronomy Monograph No. 9 Soil Science Society of America, Madison, Wisconsin. 383–412 pp.
- Hanafi M.M., Syers J.K. and Bolan N.S. 1992. Effect of lime on the dissolution of two phosphate rocks in acid soils. *Journal of Science, Food and Agriculture* 60: 155–164.
- He Z.L., Baligar V.C., Martens D.C., Rictchey K.D. and Kemper W.D. 1996. Kinetics of phosphate rock dissolution in an acidic soil amended with liming materials and cellulose. *Soil Science Society of America Journal* 60: 1589–1595.
- Hue N.V. 1992. Correcting soil acidity of a highly weathered Ultisol with chicken manure and sewage sludge. *Communications in Soil and Plant Analysis* 23: 241 – 264.
- IITA 1979. *Selected Methods for Soil and Plant Analysis*. Oyo Road, PMB 5320, Ibadan, Nigeria. 20pp.
- Jackson W.A. (1967). Physiological effects of soil acidity. In: Pearson R.W. and Adams (Eds) *Soil Acidity and Liming*. American Society of Agronomy, Madison, Wisconsin. pp. 430–463.
- Jama B., Palm C.A., Buresh R.J., Niang A., Gachengo C., Nziguheba G., and Amadolo B. 2000. *Tithonia Diversifolia* as a green manure for soil fertility improvement in Western Kenya: A review. *Agroforestry Systems* 49: 201–221.
- Jones B.J.R. and Case V.W. 1990. Sampling, Handling, and Analysing Plant Tissue Samples. In: Westerman R.L. (Ed). *Soil Testing and Plant Analysis 3rd edn*, SSSA Inc. Madison, Wisc, USA. pp. 389–427.
- Juo A.R.S. and Fox R.L. 1977. Phosphate sorption characteristics of some benchmark soils of West Africa. *Soil Science* 124: 370–376.
- Kamprath E.J. 1970. Exchangeable aluminium as a criterion for liming leached mineral soils. *Soil Science of American Proceedings* 24: 252–254.
- Kamprath E.J. and Cyde E.E. 1970. Lime response as related to percent Al saturation, solution Al, and organic matter content. *Soil Science Society of America* 34: 893–896.
- Khasawneh F.E. and Doll E.E. 1978. The use of phosphate rock for direct application to soils. *Advances in Agronomy Journal* 30: 159–209.
- Landon J.R. 1995. Booker Tropical Soil Manual. A Hand Book for Soil Survey and Agricultural and Evaluation in the Tropics and Subtropics. Longman, New York. 474pp.
- Magdoff, F.E. and Bartlett, R.J. 1980. Effect of liming acid soils on potassium availability. *Soil Science* 129 (1): 12–14.
- Martini J.A., Kochhann R.A., Signeira O.J. and Borket C.M. 1974. Response of soybeans to liming as related to soil acidity, Al and Mn toxicities and P in some soils of Brazil. *Soil Science Society American Proceedings* 38: 616–620.
- Moberg J.R. 2000. *Soil and Plant Analysis Manual*. The Royal Veterinary and Agriculture University, Chemistry Department, Copenhagen, Denmark. 133pp.
- Mtenga C.V. 2000. Effects of various liming materials on the pH and ion exchange capacities of acid soils of the central portion of Sokoine University of Agriculture (SUA) farm–Morogoro Tanzania. Unpublished Dissertation for Award of MSc degree at Sokoine University of Agriculture, Morogoro, Tanzania, pp. 40–48.
- Mutwewingabo B. 1989. Genèse, caractéristiques et contraintes d'aménagement des sols acides à horizon sombre de profondeur de la région de haute altitude du Rwanda. In: *Actes du premier séminaire Franco-Africain de pédologie Tropicale*. Lomé, 6–12 Février 1989, pp. 353–385.
- Nnadi L.A. and Haque I. 1988. Forage legumes in African crop-livestock production systems. *ILCA Bulletin* 30: 10–19.
- Nziguheba G., Palm C.A., Buresh R.J. and Smithson P. 1998. Soil phosphorus fractions and sorption as affected by organic and inorganic sources. *Plant and Soil* 198: 159–168.
- Page J.R., Miller R.H., Keeney D.R., Baker D.E., Roscoe Ellis J.R. and Rhoades J.D. 1982. *Methods of soil analysis*. II. Chemical and microbiology properties (2nd Edn). Madison, Wisconsin, USA. 1159pp.
- Palm C.A., Myers R.J.K. and Nandwa S. 1997. Combined use of organic and inorganic nutrients sources for soil fertility maintenance and replenishment. In: Buresh R.J. and Sanchez PA (Eds). *Replenishing soil fertility in Africa*. Soil Science Society of America No 51. American Society of Agronomy and Soil Science Society of America, Madison, WI, USA. Pp. 193–218.
- Rhoades J.D. 1982. Cation exchange capacity. In: Page A.L., Miller, R.H. and Keeney P.R. (Ed) *Methods of Soil Analysis Part 2*. Chemistry and mineralogical properties, Agronomy Monograph No. 9. (American Society of Agronomy Inc., Madison, Wisconsin. 149–169 pp.
- Robertson, W.K., Neller, J.R and Barlett, F.D. (1954). Effect of liming on the availability of phosphorus in soils of high to low sesquioxides content. *Soil Science Society of American Proceedings* 18: 184–187.
- Robinson J.S. and Syers J.K. 1990. A critical evaluation of the factors influencing the dissolution of Gafsa phosphate rock. *Journal of Soil Science* 41: 597–605.
- Saggar S., Hadley M.J., White R.E., Gregg P.E.H; Perrort K.W. and Cornforth I.S. 1993. Assessment of the relative agronomic effectiveness of phosphate rocks under glasshouse conditions. *Fertilizer Research* 34: 141–151.
- Sanyal S.K. and De Datta S.K. 1991. Chemistry of phosphorus transformations in soil. *Advance Soil Science* 16: 37–55.
- Savini I. (1999). The effect of organic and inorganic amendments on phosphorus release and availability from two phosphate rocks and triple superphosphate in phosphorus fixing soils. Unpublished Dissertation of MSc Degree at Nairobi University, Nairobi, Kenya, pp. 15–20
- Smith T.J. and Sanchez P.A. 1982. Phosphate rock dissolution and availability in Cerrado soils as affected by phosphorus sorption capacity. *Soil Science Society of America Journal* 46: 339–345.
- Tandon H.L.S. 1995. *Methods of Analysis of Soils, Plants, Waters and Fertilizers*. Fertilizers Development and Consultation Organisation, New Delhi, India. 144–146 pp.
- Van Straaten P. 1997. Geological phosphate resources in central east Africa. Trip report, 23 June to 21 July 1997. Department of Land Resource Science, University of Guelph, Ontario, Canada. 15pp.
- Yang X., Werner W. and Sun X. 1994. Effect of organic manure on solubility and mobility of different phosphates fertilizers in red soil. *Fertilizer Research* 38: 233–238.
- Zaharah A.R. and Bah A.R. 1997. Effect of green manure on P solubilization and uptake from phosphate rock. *Nutrient Cycling in Agroecosystems* 48: 247–255.
- Zaharah A.R. and Bah A.R. 1999. Patterns of decomposition and nutrient release by fresh *Gliricidia* (*Gliricidia Sepium*) leaves in Ultisol. *Nutrient Cycling in Agrosystems* 55: 269–277.

Evaluating performance and yield stability of some groundnut (*Arachis hypogaea* L.) varieties under irrigation in three agroecological zones of the Senegal River Valley

Madiama CISSE* & Souleymane DIALLO*

*Institut Sénégalais de Recherches Agricoles (ISRA), BP 240 Saint-Louis, Senegal; Tel: +221 961 17 51, E-mail: sbamand@yahoo.com, Fax: +221 961 18 91

Abstract

Six groundnut varieties (Fleur 11, 55-437, 73-33, 78-936, GC8-35 and Hâtive de Séfa) were tested in three agroecological zones of Senegal River Valley (SRV) (Delta, Guiers Lake zone (GLZ) and Middle Valley zone (MVZ)) during the dry season 2002 to evaluate their yield performance and stability. The yield environmental index was 3.7, 2.5 and 1.7 t ha⁻¹ in Delta, MVZ and GLZ, respectively. GC8-35 showed good response with 4.5 and 3.9 t ha⁻¹ in the Delta and MVZ, respectively. The variety was very sensitive to unfavourable environment with yield decreasing to 1.62 t ha⁻¹ in GLZ, as indicated by the coefficient of regression of 1.4190 (>1) and the negative constant of interception. With the highest general average of 3.3 t ha⁻¹, GC8-35 variety showed exceptional capacities to exploit their production potential, as shown by the deviation of +21.6 and +56% in Delta and MVZ, respectively. This variety (GC8-35) had a specific adaptation to favourable environments. Fleur 11 showed a good performance with 4.2 and 2.6 t ha⁻¹ in Delta and MVZ, respectively. It had exceptional capacities to exploit the favourable environments. It showed a deviation of +23.5, +4 and +13.5% in GLZ, MVZ and Delta zones, respectively. These results reinforced by the coefficient of regression very close to unit confirm the good plasticity of Fleur 11 (broad adaptation capacity). Hâtive de Séfa gave moderate yield of 3.6 and 2.0 t ha⁻¹ in the Delta and MVZ, respectively, with however the best response in unfavourable zone (2.4 t ha⁻¹). This variety, weakly exploited favourable environments with deviations of -20 and -2.7 % in MVZ and DELTA zones, respectively. It showed specific adaptation to unfavourable environments. The variety 78-936 gave also moderate yield of 3.4 and 2.9 t ha⁻¹ in the Delta and MVZ, respectively, with however a particularly high sensitivity to unfavourable environment, its yield decreasing to 0.4 t ha⁻¹. This variety showed negative deviation in all sites. The variety 55-437 yielded more than 3 t ha⁻¹ in the Delta and MVZ, whereas 73-33 reached 3 t ha⁻¹ only in the Delta. With a negative or zero deviation in the Delta and MVZ, these varieties showed a weak specific adaptation to unfavourable environments, in which they achieved +5.8 % deviation

Key words: *Arachis hypogaea* (L.), yield stability, Senegal River Valley

Introduction

Senegalese agricultural production comes primarily from rainfed cropping, covering nearly 96% of cultivated area. Managed irrigated area represents only 69,679 ha and 3,930 ha in the left bank of the Senegal River Valley (SRV) and the Anambé Basin, respectively (Dia et al. 1998).

Senegal was and remains, despite many problems related to production and commercialisation systems, an important groundnut (*Arachis hypogaea* L.) producer. With an average production of 691,000 t at the beginning of the sixties (Diop 1992), the country was the first African groundnut producer surpassing Sudan, Nigeria and the actual Democratic Republic of Congo. The substantial incomes from exports placed groundnut

as the first foreign currency source of the country. A decrease in cultivated area and a net increase in average yield varying between 0.66 t ha⁻¹ to 0.85 t ha⁻¹ characterised the period between 1979 and 1993 (ISRA 1998; FAO 1994). Nowadays, groundnut with a yearly export of 5,000 t of grain, 80,000 t of oil and 105,000 t of groundnut cakes (Dimanche 1999) is relegated to the fourth place as source of currencies, behind fishing, tourism and phosphate export.

Groundnuts, a leguminous plant, is largely cultivated in the tropics, especially because of its high oil (approximately 45%) and protein content (nearly 30%), its haulms used as fodder for cattle. In the Senegal River Valley, rains are feeble and delayed, with an annual average of only 250 mm with high inter-annual variability and a poor space distribution, which make rainfed cropping very random; the production security being only ensured through irrigation. It is established that under irrigation groundnut yield generally reaches 2 to 4.5 t ha⁻¹, while in rainfed cropping, it seldom exceeds 0.8 to 1.3 t ha⁻¹.

Castiaux and Philippe (1971) mentioned that the vocation of groundnut production in irrigated perimeter should be limited to kernel-seeds production and quality edible groundnut for export. In irrigated area, where groundnut is increasingly becoming an important diversification crop, especially since 1992 (Godon 2002), insufficiency of productive groundnut varieties as well as lack of adaptation of water management and farming techniques conceived for rainfed cropping agroecological zones had been identified as major constraints to its development. The share of managed area devoted to groundnut in the valley is still low (approximately 239 ha) and surpassed only that of cotton in timid introduction (SAED 2002). Moreover, in term of contribution to turnover, groundnut comes only in ninth position, far behind rice (*Oryza sativa*), onion (*Allium cepa* L.), tomato (*Lycopersicon esculentum* Mill.), sweet potato (*Ipomea batatas* L.), ladies finger (*Hibiscus esculentus* L.), water melon (*Citrullus lanatus* Thunb.), maize (*Zea mays* L.) and sorghum (*Sorghum bicolor* L.), preceding only cotton (*Gossypium barbadense*). But, considering edible groundnut demand on international market, the strong appreciation of early harvested pods (mainly in dry season) as well as the kernel-seeds production appropriateness for rainfed cropping zones, research actions were planned to support farmer in improving the farming techniques and widening the presently available varietal package. In fact, research results have identified a broad range of well-known varieties in rainfed

cropping systems (groundnut basin) but, their performance in irrigated zone of the SRV still remains poorly understood.

The yield potential in rainfed cultivation seldom exceeds 0.8–1.3 t ha⁻¹, whereas in irrigated system it can reach 2.5–4.5 t ha⁻¹. But this higher yield potential in irrigated area is greatly influenced by environmental conditions. The objectives of this study was to evaluate the productivity, adaptability and yield stability of some groundnut varieties in irrigated conditions in three agroecological zones of the SRV.

Material and methods

The Senegal River Valley (SRV), located between 10° 30" and 17° 30" of northern latitude occupies the north of Senegal from Bakel to Saint-Louis with a total of 44,127 km², corresponding to 22.4% of the total country area (DAT/PNUD 1993). Six groundnut varieties (*Fleur 11*, *55-437*, *73-33*, *78-936*, *GC8-35* and *Hâtive de Séfa*) were tested in three agroecological zones of the SRV (Delta, Guiers Lake and Middle Valley zones) during the dry season 2002 (Table 1). The locations were different in their soil (sandy, loamy clay and sandy clay) and climate characteristics (Table 2). Water was managed as usually practised by farmer according to soil types in the location. The soil in Guiers lake zones presented specifically a higher electric conductivity compared to the other sites.

Groundnut was cultivated on ridges in the Mean Valley zone (MVZ) and flat in the DELTA and Guiers Lake zone (GLZ). Cross offset was carried out after pre-irrigation. A manual sowing of one kernel-seed per hole at 2–3 cm depth was performed. In MVZ ridges (ridged cultivation) are 80 cm distant, with two sowing lines on ridge sides. In the DELTA and GLZ, sowing was realised with 40 cm spacing between lines and 20 cm between seed holes. The density obtained was 125,000 sowing holes ha⁻¹ in all sites.

Table 1. Electric conductivity, pH, C_{total}, N_{total} and soil of the different locations

	GLZ	MVZ	DELTA
Soil type	Loamy clay	Sandy clay	Sandy
CE (mS/cm)	3.3	1.1	0.5
pH _{H2O}	7.1	7.2	7.3
C _{total} (%)	3.7	3.6	3.7
N _{total} (%)	0.36	0.31	0.22

Table 2. Some characteristic of tested groundnut varieties

Varieties	Type	Genetic origin	Oil content (%)	Cycle (days)
Fleur 11	Spanish	Chinese	50–51	90
73-33	Virginia	F12 of 58-650 × 59-46	50	105–110
55-437	Spanish	Population, South America	49	90
GC8-35	Spanish	Natural Hybrid. Chico and 55-437	53	80
78-936	Spanish	Bambey	49	75
Hâtive de Séfa	Spanish	Population from Casamance	48	90

The plots received a basal fertilizer application in form of 150 kg ha⁻¹ di-ammonium phosphate (NH₄)₂HPO₄ and 150 kg ha⁻¹ of potassium sulphate (K₂SO₄), corresponding to a unit basal application of 27 kg N, 30 kg P, 63 kg K and 27 kg S ha⁻¹. At the beginning of flowering, 23 kg urea-N was applied as top-dressing.

Experimental layout was a randomised complete block design with four replications. Plants were harvested at maturity between 116 DAS in MVZ and 122 DAS in GLZ, excepted for the 73-33 harvested on the 126th and 129th DAS in DELTA and MVZ, respectively. After air-drying and sieving to 2 mm, analyses were performed on soil samples taken from 0–20 cm deep before trial implementation. The pH was measured by glass-electrode in a 1:2.5 suspension of soil in water, total C by dry combustion and total N with a CN analyser.

The moisture of pods and haulms was taken from a sample passed through a drying oven at 70 °C during three days. Haulms, pods and biomass yield are given in t ha⁻¹ at 15% water content. The 100-pods and 100-kernel weights were determined on mature pods and kernel-seeds.

The analysis of variance (ANOVA) of data was carried out on mean comparison basis using the statistical program Systat (Systat 1990). The Bartlett χ^2 or Hartlett F_{\max} tests (Statistica 1997) were performed to check variance homogeneity. In case of non-homogeneity, solutions suggested by Gomez and Gomez (1984) and Köhler et al. (2002) were applied. Correlation of some yield parameters of varieties was also studied.

The adaptability and yield stability analysis of varieties across environments was also investigated (Eberhart and Russell 1966; Hildebrand 1984; Mohsen et al. 1999; Abdelmula 1999). Hildebrand (1984) in his modified stability analysis method defines an index (coefficient) for a given environment (Stroup et al. 1993). This coefficient called environmental index (EI) is defined as the average response of all treatments

in this environment. It highlights environment effect on various genotypes. Thus, a linear regression can be obtained for each treatment as a response curve to environmental effect, represented by an equation of the form: $y = bx + a$.

where the yield or the biomass y_i of a variety i is expressed according to environmental index $EI(x)$ affected by a slope b or coefficient of regression and a variable of interception of y (a). This variable (a) indicates the relative performance of a variety in a highly stressed environment. High variable of interception relates to elevated performance in hostile environment. The determination coefficient R^2 indicates the share of environmental effect on yield and biomass discrepancy. According to Eberhart and Russell (1966), the stability analysis based on regression coefficient indicates the variety choice. A regression coefficient largely higher than unit means that the variety is too sensitive to environmental changes, whereas, a regression coefficient, lower than unit indicates that the variety is unable to effectively exploit a high potential yielding environment. In other terms, a variety with a regression coefficient higher than one is regarded as adapted to favourable environments, whereas a variety with regression coefficient lower than unit is considered as adapted to unfavourable environments (Abdelmula 1999). The mean square deviation (s^2d) in the regression method is also regarded as a stability parameter. The varieties and environments with low values of s^2d are seen as having a high stability. Other authors consider that the variance σ^2 across the different location can be regarded as stability indicator. In such cases, a low variance across the environments is a proof of high stability.

An equation of the linear regression estimates yield and biomass of different varieties depending on environmental index. The coefficient of regression and the constant of interception in the regression equation, the variance of yield and biomass across the different environment as well as their general average are key indicators of variety performance.

Table 3. Deviation of regression (DRIE) of biomass (BIOM) and global biomass mean (DRGBIO) related to environmental index

Varieties	GLZ		MVZ		DELTA		All sites	
	BIOM t ha ⁻¹	DREI (%)	BIOM t ha ⁻¹	DREI (%)	BIOM t ha ⁻¹	DREI (%)	BIOM t ha ⁻¹	DRGBIO O(%)
Fleur 11	9.0	+30.4	9.9	-14.7	11.0	+22.2	10.0	+9.9
55-437	7.7	+11.6	12.8	+10.3	9.0	0	9.8	+7.7
73-33	8.3	+20.3	15.3	+31.9	9.7	+7.8	11.1	+22
78-936	1.5	-78.3	7.6	-34.5	5.7	-36.7	5.0	-45.1
GC835	5.4	-21.7	11.9	+2.6	9.4	+4.4	8.4	-7.7
H. Séfa	9.6	+39.1	12.0	+3.4	9.1	+1.1	10.3	13.1
LSD _{0.05}	2.0	-	3.1	-	1.9	-	1.36	-
EI	6.9	-	11.6	-	9.0	-	9.1	-

Results

Biomass production and yield performance

Biomass production

In the GLZ, environmental impact was highly marked on biomass varying between 1.5 t ha⁻¹ for 78-936 and 9.6 t ha⁻¹ for Hâtive de Séfa, which slightly preceded the Fleur 11 with 9.0 t ha⁻¹. The 78-936 and GC8-35 were characterised by a relatively feeble biomass. The varieties are statistically separated by an LSD_{0.05} of 2.0 t ha⁻¹ (Table 3). Biomass production in the MVZ was particularly marked by the varieties 73-33 and 55-437, producing 15.3 and 12.8 t ha⁻¹, respectively (Table 3). The 78-936 variety showed the lowest biomass production of only 7.6 t ha⁻¹, primarily due to the low above ground biomass of this variety with a high defoliation rate preceding maturity.

Fleur 11 and 73-33 produced the highest biomass in the DELTA with 11.0 and 9.8 t ha⁻¹, respectively (Table 3). The 78-936 variety, known for its weak above ground biomass production, yielded only 5.7 t ha⁻¹. Hâtive de Séfa and 73-33 with respective averages of 10.3 and 11.1 t ha⁻¹ dominated the biomass production across sites, whereas 78-936 arrived with the weakest biomass, reaching only 4.9 t ha⁻¹. Biomass production per site was dominated by the MVZ followed by DELTA and GLZ, as indicated by the global averages, corresponding to a biomass environmental index of 11.6, 9.0 and 6.9 t ha⁻¹, respectively (Table 3).

Yield performance

The three locations revealed a yield environmental index of 3.7, 2.5 and 1.7 t ha⁻¹ in the Delta, Middle Valley (MVZ) and Guiers Lake zone (GLZ), respectively. The 78-936 variety was affected by the GLZ

environment effect, in with yield decreased drastically to 0.4 t ha⁻¹ (Table 4). The relatively weak vegetative development confirms the high sensitivity of this variety against environmental stress. Thus, this variety would not be recommended in an environment with confirmed or doubtful stress. Hâtive de Séfa and Fleur 11 performed well in GLZ, where they yielded 2.4 and 2.1 t ha⁻¹, respectively.

GC8-35 with 3.9 t ha⁻¹ gave the higher yield in MVZ, whereas Fleur 11 and 55-437 arrived with 2.6 and 2.5 t ha⁻¹, respectively. An LSD_{0.05} of 1.0 t ha⁻¹ separated varieties. The GC8-35 and the Fleur 11 gave higher yield in DELTA with 4.5 and 4.2 t ha⁻¹, respectively (Table 4). The lowest yield in this site was obtained by the 73-33 reaching however 3.0 t ha⁻¹. The difference was not however significant at 95% confidence level.

Across sites, the GC8-35, Fleur 11 and Hâtive de Séfa had the best performance, considering yield average reaching 3.3, 3.0 and 2.7 t ha⁻¹, respectively (Table 4). With site yield average of only 1.7 t ha⁻¹, GLZ confined varieties in stress situation (Table 4). The MVZ improved global yield average by 47% compared to GLZ, reaching 2.5 t ha⁻¹, whereas DELTA improved it by 48% compared to MVZ, producing 3.7 t ha⁻¹. The multifactorial variance analysis carried out on pods yield showed a highly significant difference between varieties, between sites as well as a significant interaction between sites and varieties.

Biomass and yield stability

Biomass stability

The linear regression carried out on biomass across the environmental indices is indicated in Table 5. BIOM_i

Table 4. Deviation of the regression of yield means (DREI) and global yield mean (DRGY) related to environmental index

Varieties	GLZ		MVZ		DELTA		All sites	
	Yield t ha ⁻¹	DREI (%)	Yield t ha ⁻¹	DREI (%)	Yield t ha ⁻¹	DREI (%)	Yield t ha ⁻¹	DRGY (%)
Fleur 11	2.1	+23.5	2.6	+4	4.2	+13.5	3.0	+15.4
55-437	1.8	+5.9	2.5	0	3.3	-10.8	2.5	-3.8
73-33	1.8	+5.9	1.8	-28	3.0	-18.9	2.2	-15.4
78-936	0.4	-76.5	2.4	-4	3.4	-8.1	2.1	-19.2
GC8-35	1.6	-5.9	3.9	+56	4.5	+21.6	3.3	+26.9
H. Séfa	2.4	+41.2	2.0	-20	3.6	-2.7	2.7	+3.8
LSD _{0.05}	0.9	-	1	-	NS	-	0.57	-
EI	1.7	-	2.5	-	3.7	-	2.6	-

represents the biomass (t ha⁻¹) of indicated variety *i*, EI, the biomass environmental index (t ha⁻¹), R² the coefficient of determination, σ² the variance and B_{mean} the general average of biomass (t ha⁻¹) yielded by a variety across the three sites. The coefficient of determination was too low for Fleur 11 biomass. Only 16% of its biomass deviation could be justified by the environmental index (Table 5). For the global biomass average, the 73-33 and Hâtive de Séfa gave the best performances. The 73-33 was sensitive to the environments with a relatively high depressive effect. Hâtive de Séfa was characterised by a relatively moderate gain from favourable environments with remarkable yielding capacity in unfavourable environments. The 78-936 variety was very sensitive to environment with stress. The varieties 55-437 and GC8-35 with regression coefficients closest to unit (1.175 and 1.168, respectively) were regarded as relatively stable considering their biomass.

Yield stability

Linear regression performed on yield across environmental indices is presented in Table 6. Yi represents

the yield (t ha⁻¹) of indicated variety *i*, EI, the environmental index (t ha⁻¹), R² the coefficient of determination, σ² the variance and Y_{means} the general yield mean (t ha⁻¹) of a variety across three sites. The results showed a very good performance of GC8-35 with 4.5 and 3.9 t ha⁻¹ in Delta and Middle Valley zones, respectively. This variety was however very sensitive to unfavourable environment with a yield decreasing to 1.62 t ha⁻¹ in the Guiers lake zone, as indicated by the coefficient of regression of 1.4190 (>1) and the negative constant of interception (Table 6). The yield variance was the highest of all through the three sites. With the highest general average of 3.3 t ha⁻¹, this variety is to be encouraged in the favourable environments, where it showed exceptional capacities to exploit their production potential, as shown by the deviation from +21.6 and +56% in the sites of Delta and Middle Valley zones, respectively (Table 4). There is a real risk to invest on this variety in unknown environments. With a deviation of -5.6% compared to EI of GLZ, the incurred losses were accentuated if yield was compared to those obtained in Delta and MVZ. This variety had a specific adaptation to favourable environments. Fleur 11

Table 5. Equation of regression of biomass, determination coefficient (R²) and biomass general mean (B_{mean}) related to environmental index (EI)

Equation of linear regression	R ²	Variance σ ²	Y _{mean} (t ha ⁻¹)
BIOM _{F11} = 0.167 * EI + 8.440	0.16	1.003	10.0
BIOM ₅₅ = 1.175 * EI - 0.872	0.95	7.023	9.8
BIOM ₇₃ = 1.607 * EI - 3.463	0.92	13.72	11.1
BIOM ₇₈ = 1.349 * EI - 7.362	0.92	9.743	4.9
BIOM _{GC} = 1.168 * EI - 2.133	0.89	10.75	8.5
BIOM _{HS} = 0.534 * EI + 5.384	0.59	2.403	10.2

Table 6. Equation of regression of yield function of environmental index (EI), coefficient of determination (R²), variance (σ²) and general mean yield (Y_{mean}) of varieties across sites

Equation of linear regression	R ²	Variance σ ²	Y _{mean} (t ha ⁻¹)
Y _{F11} = 1.0378 * EI + 0.2214	0.95	1.203	3.0
Y ₅₅ = 0.7852 * EI + 0.4645	0.99	0.563	2.5
Y ₇₃ = 0.6586 * EI + 0.4851	0.85	0.480	2.2
Y ₇₈ = 1.4853 * EI - 1.8648	0.92	2.333	2.1
Y _{GC} = 1.4190 * EI - 0.3770	0.85	2.343	3.3
Y _{HS} = 0.6139 * EI + 1.0722	0.59	0.693	2.7

variety showed good performance with 4.2 and 2.6 t ha⁻¹ in Delta and MVZ, respectively. It had exceptional capacities to exploit favourable environments. Its variance through the sites placed it in fourth position behind 73-33, 55-437 and Hâtive de Séfa, with however general yield average higher than those of these varieties. It showed deviations of +23.5, +4 and +13.5% in GLZ, MVZ and DELTA, respectively. This result reinforced by the coefficient of regression very close to unit has confirmed the good plasticity (broad adaptation capacity) of Fleur 11. Hâtive de Séfa gave moderate yield of 3.6 and 2.0 t ha⁻¹ in Delta and MVZ, respectively, with however the best response in unfavourable zone, with 2.4 t ha⁻¹. The yield variance across sites placed it in third position behind 73-33 and 55-437, but with a general yield average reaching only 2.7 t ha⁻¹, behind GC8-35 (3.3 t ha⁻¹) and Fleur 11 (3 t ha⁻¹). This variety, weakly exploited favourable environments with deviations of 20 and 2.7% in MVZ and Delta zones, respectively. It showed specific adaptation to unfavourable environments. The 78-936 gave also moderate yield of 3.4 and 2.9 t ha⁻¹ in Delta and MVZ, respectively, with however the highest sensitivity to unfavourable environment, with yield decreasing to 0.4 t ha⁻¹. This variety showed negative deviation in all locations with particular sensitivity to unfavourable environment. The 55-437 yielded more than 3 t ha⁻¹ in Delta and MVZ, whereas the 73-33 reached 3 t ha⁻¹ only in the Delta. With a negative or zero deviation in MVZ and Delta, these varieties hold weak specific adaptation to unfavourable environments, in which they showed +5.8% of deviation in corresponding sites. As perspective, a participatory evaluation of these varieties in dry and rainy season will help to evaluate the acceptability of these varieties by farmers.

Fleur 11 with its coefficient of regression of 1.0378, very near to unit showed the best yield stability and an averaged sensitivity to environments with stress (Table 6). The variety 78-936 and GC8-35, with respective regression coefficients of 1.4853 and 1.4190 are very sensitive to the environmental changes. Their negative interception variable confirmed their poor response in the Guiers Lake zone. The 55-437 and 73-33 was limited in optimally exploiting favourable environments, but with averaged sensitivity to unfavourable environments. Hâtive de Séfa showed a poor capacity to exploit the favourable environment but remained particularly interesting through its yielding capacity in the environments with stress as shown by the constant of interception of 1.0722.

Hundred Pods Weight (HPW) and Hundred Kernel Weight (HKW)

These two technological characteristics are important yield component and basis for edible groundnut classification using pods and kernel calibre (Dimanche 1999). The varieties 78-936, 73-33 and Fleur 11, respectively gave a hundred pods weight (HPW) of 140.3, 118.3 and 105.9 g, whereas Hâtive de Séfa produced the weakest weight in the GLZ, even giving less than 55-437, which showed the weakest HPW in the other sites (Table 7). This variety yielded however the best in this environment. The best hundred kernel weight (HKW) in the GLZ was produced by the 78-936, 73-33 and Fleur 11, which recorded 58.7, 47.2 and 46.0 g, respectively.

In MVZ, HPW decreased to 65.1 g with the 55-437, whereas 73-33 was the best variety with 102.4 g. The best HKW in MVZ was achieved by Fleur 11, 78-936 and 73-33, performing 43.6, 40.9 and 40.5 g for hundred-groundnut kernel, respectively (Table 7). In the DELTA, the 78-936, Fleur 11 and Hâtive de Séfa varieties attained the best HPW with 166.9, 135.8 and 130.6 g, respectively. The 55-437 and GC8-35 with 98.8 and 105.9 g had the lowest HKW. With 127.4 g general average, HPW means were separated by a LSD_{0.05} of 10.2 g. The variety 78-936, 73-33 and Fleur 11, respectively with 70.9, 61.2 and 56.5 showed the best HKW calibre in the DELTA, while GC8-35 and 55-437 arrived just with 45.3 and 42.5 g. By compiling result from all sites, the 78-936 variety reached a HPW average of 129.2 g (Table 7) due to its particularly high HPW in the DELTA. The 55-437 and GC8-35 confirmed their small calibre with a HPW of 81.4 and 92.4 g, respectively. The general averages for all sites confirmed the prevalence of the varieties 78-936, 73-33 and Fleur 11 with 56.8, 49.6 and 48.7 g for hundred kernel, whereas 55-437 recorded the smallest weight with 34.3 g.

Significant differences between the 100-pods weight (HPW) of the three study sites, with 127.4, 102.6 and 85.8 g of general means, were respectively registered for DELTA, GLZ and MVZ. DELTA environmental index showed an improvement of 24 and 48.5% compared to GLZ and MVZ, respectively (Table 7). Hundred-kernel weight (HKW) of sites was characterized by environmental indices of 55.2, 44.1 and 36.1 g for DELTA, GLZ and MVZ, respectively. The HKW was improved by the DELTA site by 25.2 and 52.9% compared to GLZ and MVZ, respectively.

Table 7. Hundred-Pods Weight (HPW) and Hundred-Kernel Weight (HKW) of different varieties in the DELTA, GLZ and MVZ locations

Variétés	Hundred-Pods Weight (g) HPW				Hundred-Kernel Weight (HKW) (g)			
	GLZ	MVZ	DELTA	All sites	GLZ	MVZ	DELTA	All sites
Fleur 11	105.9	98.7	135.8	113.4	46.0	43.6	56.5	48.7
55-437	80.2	65.1	98.8	81.4	33.1	27.2	42.5	34.3
73-33	118.3	102.4	126.6	115.7	47.2	40.5	61.2	49.6
78-936	140.3	80.5	166.9	129.2	58.7	40.9	70.9	56.8
GC8-35	92.4	79.1	105.9	92.4	36.3	29.4	45.3	37.7
H. Séfa	78.4	89.0	130.6	99.4	43.2	35.2	54.9	44.4
LSD _{0.05}	13.8	19.0	10.2	32.6	5.7	7.3	5.4	13.3
EI (environmental index)	102.6 ^a	85.8 ^b	127.4 ^c	105.3	44.1 ^a	36.1 ^b	55.2 ^c	45.2

HPW and HKW environmental index with different letter are significantly different at $P < 0.05$

Yield component

The significant linear regression allows to express the (pods) yield ($t\ ha^{-1}$) according to plant density at harvest (DH), pods number per plant (PNP) and 100-pods weight (HPW) according to the equation:

$$Y_{\text{pods}} = (0.287 * DH) + (0.039 * PNP) + (0.010 * HPW) - 2.133$$

where Y_{pods} represents the yield of pods in $t\ ha^{-1}$, DH, the plant density at harvest (plant per m^2), PNP the pods number per plant and HPW the 100-pods weight (g). The coefficient of determination R^2 was equal to 0.54.

As well, the yield of selected kernel-seeds (Y_{sels}) in $t\ ha^{-1}$ is expressed with a highly significant regression according to plant density at harvest (DH), pods number per plant (PNP), shelling yield (SH_y) in % and the 100 kernel-seeds weight (HKW) considering following equation:

$$Y_{\text{sels}} = (0.17 * DH) + (0.017 * PNP) + (0.041 * SH_y) + (0.011 * HKW) - 4.014$$

The yield of hand picked selected kernel-seed (Y_{sels}) can be a function of pods yield (Y_{pods}) and percentage of attacked or damaged pods (PS_{pods}) as well. The analysis of variance of the linear regression is significant with a coefficient of determination R^2 of 0.84. The yield of selected seed can be represented by the equation:

$$Y_{\text{sels}} = 0.473 * Y_{\text{pods}} - 0.020 PS_{\text{pods}} + 0.432$$

Discussion

In Senegal, groundnut production is primarily performed under rainfed cropping, with maximum yield varying between 0.8 and 1.3 $t\ ha^{-1}$. The contribution of irrigated zone to national groundnut production could be considerable with yield of more than 2.5 $t\ ha^{-1}$. In the 3 studied agroecological zones, the difference between sites was clear. The major constraint in MVZ was heavy soil characteristics and difficulty in water management, while in GLZ, the degree of salinity in groundnut tolerance limit was the principal limiting factor. Concerning yield, the sites were characterised by environmental indices varying from 3.7, 2.5 and 1.7 $t\ ha^{-1}$ in the DELTA, MVZ and GLZ, respectively. The GLZ site presented the lowest index, whereas the DELTA site with a sandy soil precedes the MVZ site on heavy soil, which was unfavourable to pegs incrustation and good water management, with possible pod loss during harvest, but with high production potential. The analysis of variance showed a significant difference between these environmental indices. The least significant difference (LSD_{0.05}) test of Fischer (Systat 1990) indicated a significant difference between environments coupled two by two.

Fleur 11 remains an interesting variety but it was preceded by GC8-35 in DELTA and MVZ concerning pods yield, while for selected kernel-seed yield, it was preceded by GC8-35 only in MVZ. GC8-35 was quite interesting. Godon (2002) reported that GC8-35 yielded equally or slightly higher than Fleur 11. However, with its 100-pods weight, it preceded only 55-437. Indeed, it had a HPW of 92.4 g against 113.4 g for Fleur 11, which improved its HKW by 33.4% compared to GC8-35. Amongst other things, this variety

was very sensitive and behaved relatively poorly in site with low environmental index, preceding only the 78-936.

Clouvel (1992) carried out various tests on diversification crops on light soils in the Guiers Lake zone, involving varietal trials, particularly on the varieties 55-437 and 57-422, on farming techniques, irrigation and water management as well as crop protection. These tests gave yield varying between 3.1 and 3.4 t ha⁻¹ of pods and 5–7 t ha⁻¹ of haulms. Clouvel (1992), Mayeux and Annerose (1995) carried out trials on irrigated groundnut farming techniques bearing on geometry, sowing density, fertilisation and irrigation management.

The 100-pods (HPW) and 100-kernel seeds (HKW) weights, are apart their contribution in yield elaboration important selection criterion for varieties intended for edible and confectionery groundnut production. Indeed, pods and kernel-seeds weight were determining in products marketing, as important criterion for edible groundnut classification, involving cavity number per pod, pods and kernel form, shape of pod beak and oil content. Besides the differences between varieties, environments could contribute in improving these characters.

The HPW and HKW are improved by the effect of DELTA site at a rate of 48 and 24% compared to MVZ, while a respective improvement of 24 and 25% was noted compared to GLZ. Mayeux and Martin (1996) showed that for short cycle groundnut varieties, dry matter of above ground biomass produced 60 days after sowing is an adequate indicator for crop capacity to form and conserve pods. The biomass dry matter at harvest being used as indicator for crop capacity to fill seeds (correlation between 100-seeds weight and biomass at harvest). These authors noted that, 100-seeds weight of varieties with big kernels, are affected by the fertility conditions.

In MVZ with heavy soil, a compensation of low HPW, intervened with an increase in pod number per plant, where it reached 48.2 pods per plant against 36.2 in DELTA. This showed a high yield potential in these heavy soils. However, cropping these soils remains more difficult because of their heaviness and difficulty in ensuring correct water management. This high potential also confirmed by pegs production in MVZ site militates in favour of groundnut production in these soils. Suitable measurements, including soil, crop and water management are necessary, considering that groundnut cultivation is particularly recommended in light soil types locally named DIERI and FONDE.

Fleur 11, the most adaptable (according to Finlay and Wilkinson 1963), but the most stable according to Eberhart and Russell (1966) must be selected based on regression coefficient value (1.0378) very closed to unit. But, according to Hildebrand (1984, 1990), recommendation domains, within which specific technologies excel, must be described. In other word, parallel to yield stability analysis, it is important to check for variety, which take advantage in favourable environments or maintain yield even in poorer environments. GC8-35 and Hâtive de Séfa are good example in our study, because performing well in DELTA and MVZ and in GLZ, respectively.

Conclusion

This study addressed performance of some groundnut varieties in three agroecological zones of Senegal River Valley. The results obtained are related to dry season 2002. In prospect, the study of variety compartment should be extended to other locations and with trials in dry as well as in rainy season, to determine their space-time variations and to better determine space-time adaptability of these varieties. In addition, other varieties with large pods should comprise the varietal package to be tested. For development of irrigated cultivation, other studies related to farming techniques should be undertaken. These studies should integrate dates, sowing modes, irrigation, fertilization, plant health protection, and tolerance to soil compactness, as well as harvest and post-harvest crop management. A broader range of varieties of Virginia type (57-422, 73-27, 73-28, H 75-0, GH 119-20 and 756A) with large pods still need to be investigated in irrigated cultivation.

References

- Abdelmula A.A. 1999. Genetic improvement of drought tolerance in Faba beans (*Vicia faba* L.). Dissertation. Cuvillier Verlag Goettingen.
- Castiaux J. and Philippe J. 1971. Rapport de synthèse d'enquête d'évaluation et de programmation. Projet pour le développement de la recherche agronomique et de ses applications dans le bassin du fleuve Sénégal, 133 pages.
- Clouvel P. 1992. Rapport d'activité: Arachide irriguée N° 3. ISRA/CEE.
- DAT/PNUD 1993. Comm. Régionale Fleuve: Rapport d'avant projet du Schéma National d'Aménagement du Territoire.
- Dia M., Gaye I., Sylla M.M., Gueye A.A. and Diallo Y. 1998. Rentabilité et compétitivité de la filière rizicole du Sénégal. Min. Agriculture & Hydraulique.
- Dimanche P. 1999. L'arachide de bouche – un produit valorisant mais exigeant GGP Newsletter 3.

- Diop A.B. 1992. Les paysans du bassin arachidier: Conditions de vie et comportement de survie. *Politique Africaine* 45: 39–61.
- Eberhart S.A. and Russell W.A. 1966. Stability parameters for comparing varieties. *Crop Sci.* 6: 36–40.
- FAO 1994. FAOSTAT Database. <http://www.fao.org/waicent/faostat/agricult.html>.
- Finlay K.W. and Wilkinson G.N. 1963. The analysis of adaptation in a plant breeding programme. *Aust. J. Agric. Res.* 14: 742–754.
- Godon P. 2002. Rapport d'activités de fin de contrat d'assistance technique (1998–2002). PSI-ISRA.
- Gomez K.A. and Gomez A.A. 1984. *Statistical procedures for agricultural research*. Wiley & Sons, New York.
- Hildebrand P.E. 1984. Modified stability analysis of farmer managed, on-farm trials. *Agron. J.* 76: 271–274.
- Hildebrand P.E. 1990. Modified stability analysis and on farm research to breed specific adaptability for ecological diversity. Pp. 169–180. In: Kang M.S. (ed.): *Genotype by Environment interaction and plant breeding*. Louisiana State Univ., Baton Rouge.
- ISRA 1998. *Le projet d'entreprise de l'ISRA ou la recherche agricole sénégalaise à l'horizon 2015*. ISRA-Edition.
- Köhler W., Schachtel G. and Voleske P. 2002. *Biostatistik – Eine Einführung für Biologen und Agrarwissenschaftler*. Springer-Verlag Berlin.
- Mayeux A. and Martin J. 1996. Diagnostic de l'élaboration du rendement de l'arachide par l'analyse de ses composantes et de la croissance. CORAF-ISRA-CERAAS. Symposium Base Centre Arachide: L'arachide cultivée en zones sèches – Stratégies et méthodes d'amélioration de l'adaptation à la sécheresse" CNRA Bambey, Sénégal. 17–20 Décembre 1996.
- Mayeux A. and Annerose D. 1995. Synthèse des recherches conduites au Sénégal de 1991 à 1992 dans le cadre du projet "Mise au point de techniques de culture de l'arachide irriguée". Contrat CEE/DGXII. ISRA-CIRAD.
- Mohsen B., Moncef B.H. and Lazhar S. 1999. Adaptation et stabilité du rendement de trois espèces céréalières dans les régions semi-arides et sub-humides de la Tunisie. *Sécheresse* 10 (4): 273–279.
- SAED 2002. Septième lettre de mission. SAED.
- STATISTICA 1997. *Statistica for Windows 5.1*, Statsoft Inc. Tulsa, USA.
- Stroup W.W., Hildebrand P.E. and Francis C.A. 1993. Farmer participation for more effective research in Sustainable agriculture. *American Society of Agronomy ASA* 56: 153–186.
- SYSTAT 1990. *Systat for WINDOWS 1990–1994*. Statistics. Version 5.05, Systat Inc., Evanston, Illinois, USA.

Assessment of the contribution of tied ridges and farmyard manure application to sorghum production in semi-arid areas of Tanzania

Kabanza^{1*} A.K. and Rwehumbiza F.B.R.¹

¹Department of Soil Science, Sokoine University of Agriculture, P.O. Box 3008, Morogoro Tanzania; Telephone: +255754563324, +255754565840, +255784234830, +255232600798, +255232603999, Fax: +255232603259, Present address: Kabanza. A.K., P.O. Box 3111, Morogoro Tanzania, E-mail: kkaggwa@yahoo.co.uk*, rmbiza@suanet.ac.tz; *Corresponding author

Abstract

A field study was conducted in Tanzania on a continuing five years old tillage trial to assess the residual effect of unmanured and manured tied ridges on some soil physical properties as well as on sorghum grain yield. Treatments tested were: no-till (NT), shallow tied ridges (STR), deep tied ridges (DTR) and annually made tied ridges (ADTR). The test crop was sorghum, variety, Tegemeo. There was no significant ($P>0.05$) difference in residual organic matter (OM) content among tillage treatments within unmanured and manured plots. Manure application significantly ($P<0.05$) affected sorghum grain yield. Compared to the control (No Primary Tillage with no FYM-NPT), yield was more than four times in the NPT+F (No Primary Tillage that received manure five years ago). Sorghum grain yield of the Control was significantly ($P<0.05$) increased by tillage methods. The annually made tied ridges had the highest grain yield of 2 t ha^{-1} while control plots had 0.4 t ha^{-1} . In treatments referred to as having “residual tied ridges”, the tied ridges were established in 1996/97 season and have been under experiment as residual tied ridges with very limited repair since then. Grain yield of 1.9 t ha^{-1} under residual tied ridges after five seasons was statistically comparable to the yield from annually made tied ridges (ADTR). It was concluded that residual tied ridges could be utilized for up to five seasons for improved sorghum grain yield. The reduced tillage and the increased sorghum grain yield under the residual tied ridges are making the system attractive to farmers in semi-arid areas

Key words: farmyard manure, no-till, semi-arid, sorghum, tied ridges

Introduction

According to the Land Resource Development Center (LRDC) (1987), an estimate of more than 50% of the land in Tanzania is semi-arid. The semi-arid regions in Tanzania are the zones that are prone to unreliable rainfall ranging from 450–750 mm/year. They include Dodoma, Singida, some parts of Arusha, Kilimanjaro, Shinyanga, Mbeya and Tabora regions.

In semi-arid areas, the primary factor limiting crop production is moisture deficiency. The amount of rainfall, its frequency and duration are usually erratic (Swai, 1999; Rwehumbiza *et al.*, 2000). Due to climatic condition explained above there have been attempts to

optimize crop yield by planting drought tolerant crops particularly sorghum and millet in semi-arid areas of Tanzania. Planting of drought tolerant crops has however not eliminated crop failure due to water stress (Mahoo *et al.*, 1999). Apart from unfavourable climatic conditions, low crop yield potential is mainly due to poor tillage practices, which are inappropriate for soil water conservation. There is ample evidence indicating that application of FYM increases soil available water capacity (Tisdale and Oades, 1982; MacLean and More, 1979; Kramer and Boyer, 1995; Swai, 1999; Rwehumbiza *et al.*, 2000). Studies conducted in Hombolo, have shown that, the use of tied ridges associated with application of FYM increased yields through

the conservation of moisture (Hatibu *et al.*, 1995; Swai and Rwehumbiza, 1998; Reuben *et al.*, 1998; Swai, 1999; Rwehumbiza *et al.*, 2000).

Despite the obvious advantages farmers have not adopted tie-ridging techniques mainly because the land preparation is undertaken before the onset of rains when soils are dry and therefore too hard to till with a hand hoe (Rwehumbiza *et al.*, 2000). In addition, the seasonal construction of tied ridges is a tedious and time-consuming task (Georgis, 2000). The lack of means of transport to carry FYM to distant crop fields and limited draft power for land tilling are bottlenecks in the adoption of the practice (Rwehumbiza *et al.*, 2000). Farmers have instead developed a less-demanding No-Primary-Tillage (NPT) practice known as “*kuberega*” in local language. *Kuberega* involves superficial scratching of the soil surface with a hand hoe to suppress weeds before sowing (Rwehumbiza *et al.*, 2000). Although the NPT practice suits resource poor farmers since it requires very little draft power, it has low performance in terms of crop yields, mainly due to poor soil water conservation caused by high run-off (Hatibu *et al.*, 1995). Reducing the time and cost spent on constructing tied-ridges by making ridges once every four or five years, instead of seasonally, can make the practice more acceptable to farmers (Anschütz *et al.*, 1997 and Rwehumbiza *et al.*, 2000). In Hombolo, tied ridges were established in 1996/97 season and have been under experiment as residual tied ridges since then. Work by Hatibu *et al.* (1995) at Hombolo,

on sandy clay loam soils, demonstrated that tie ridging produce the highest sorghum grain yield as compared to flat tillage and no till. However, a Rapid Rural Appraisal in semi-arid parts of Dodoma region showed that farmers liked the No-Primary tillage (NPT) “*kuberega*” practice in sorghum-livestock-maize (SLIM) farming systems (Mahoo *et al.*, 1996) but were reluctant to the tie ridging system.

The purpose of this study was to assess the benefits of using residual tied-ridges and FYM application as soil water harvesting technique in the production of sorghum in semi-arid areas of Hombolo in Dodoma region, in Tanzania.

Materials and methods

Site

The research work was conducted at Hombolo Agricultural Research Institute (ARI) of the Ministry of Agriculture and Food Security, in Dodoma, Tanzania. Hombolo is located about 58 km North-East of Dodoma Municipality at 05°45’S latitude, 35°57’E longitude and 1020 m above sea level. The soil of experimental site is fairly uniform, based on colour and texture (Hatibu *et al.*, 1995) and has been classified by Mahoo and Kaaya (1993) as Typic Ustorthent. The physico-chemical status of surface soil (0–20 cm) of the experimental site is presented in Table 1. The

Table 1. Physico-chemical status of the top (0–20 cm) of the experimental site

Soil property	Mean \pm S.E	Interpretation
Particle size		
Sand (%) (2000 μ m–20 μ m)	67.15 \pm 1.98	
Silt (%) (20 μ m–2 μ m)	1.86 \pm 0.37	
Clay (%) (<2 μ m)	30.99 \pm 1.63	
Texture class	SCL	Sand clay loam
pH		
In 1:2.5 water	5.55 \pm 0.01	Medium
In 1:2.5 KCl	4.03 \pm 0.01	
Organic carbon (%)	0.53 \pm 0.01	Very low
Total N (%)	0.05 \pm 0.01	Very low
Extractable P (mg/kg)	2.38 \pm 0.19	Low
Exchangeable bases		
Na (me/100g)	0.40 \pm 0.01	Medium
K (me/100g)	0.63 \pm 0.01	Medium
Ca (me/100g)	0.25 \pm 0.01	Very low
Mg (me/100g)	0.13 \pm 0.01	Very low
Cation Exch. Capacity (CEC)	13.97 \pm 1.07	Medium

S.E = Standard error

Table 2. Treatment description

Treatment	Description
1	NPT: No Primary Tillage with no FYM
2	NPT+FYM: No Primary Tillage with 30 t ha ⁻¹ of FYM
3	STR: Shallow depth of tillage with tie ridging without FYM
4	DTR: Deep depth of tillage with tie ridging without FYM
5	STR+FYM: Shallow depth of tillage with tie ridging and 30 t ha ⁻¹ FYM
6	DTR+FYM: Deep depth of tillage with tie ridging and 30 t ha ⁻¹ FYM.
7	ADTR+FYM: Same as in (6) above except that it is ploughed annually

mean annual precipitation in Hombolo is 589 mm. Overall mean annual rainfall for 18 years (1982–2000) was 658 mm.

Experiment set up and management

Experimental plots were established in 1996/97 cropping season; the plots had been under intensive sorghum cultivation for the past five years. The 2001/02 cropping season was a continuation of the previous studies on the site. Seven treatments comprising different water conservation techniques (tillage practices) and FYM were arranged in Randomised Complete Block Design with three replications. Table 2 represents the treatments description. These were:

Treatment 1 represented the current practice by many farmers and served as the control in this study. Treatment 2 represented a practice by many farmers on small plots located near livestock bomas because of the ease of transporting FYM. The manure is broadcast on the field before planting but no attempt is made to incorporate it into the soil. Treatment 3 consisted of making of tie-ridges at the beginning of the experiment after shallow tillage with hand hoe. Initially (1996/97) the field was dug to a depth of 10 cm using a traditional hand hoe, the ridges were made at 0.75 m apart and tied at 1.5 m intervals, which produced a series of basins. Treatment 4 was similar to treatment 3 except that the ridges were made following deep tillage with a tractor-drawn plough. Initially (1996/97) the field was ploughed to a depth of 20 cm. The ridges were made at 1m apart and tied at 1.5 m intervals. Treatment 5 was similar to treatment 3 except that 30 t ha⁻¹ of FYM was applied before making the ridges. Treatment 6 consisted of making one deep tillage at the beginning of the experiment, application of FYM at 30 t ha⁻¹ followed by formation of ridges. Treatment 7 was

similar to treatment 6 above except that it was ploughed annually.

During the second (1997/98), third (1998/99), and fifth (2000/01) seasons land preparation was limited to the removal of weeds without ploughing except in treatment 7 which was ploughed annually. The size of each plot was 20 m by 10. The test crop was sorghum variety Tegemeo. Five seeds were planted per hill by dibbling at a spacing of 0.75 m by 0.4 m for treatment with no tillage (local practice) or with shallow tied ridges. In the deep tied ridge treatments seed were planted at a spacing of 1 m by 0.3 m.

The experimental field in 2001/02 cropping season was prepared using a hand hoe and it was done on 26 November, 2001. Land preparation consisted of the collection, removal of previous crop residues, grasses and weeds from the field which previously had tied ridges grown with sorghum variety Tegemeo since 1996/97 season and these were burned in between plots. The previous tied ridges (residual tied ridges) both shallow and deep ones were maintained to their original shape without altering their dimensions. The absolute control plots (no-till) which are analogy of the local practice (*kuberega*) were prepared in the same way as what farmers normally do every year.

Planting was done on 6 December, 2001. Thinning to two seedlings per hill was done five weeks after emergence giving a plant population of 66,667 plants/ha. The delay in thinning was due to the dry spell, which persisted for almost two weeks after emergence.

Management of the experimental plots

The crop was weeded three times, 17 days after planting (DAP), 50 DAP and 85 DAP. As in the previous years, weeding was done using a hand

hoe. The study was on residual tied ridges, so no inorganic fertilizer or manure was applied during the 2001/02 cropping season. This was done purposely to reflect farmers practice in the study area as most of them do not apply inorganic fertilizer or manure.

Data collection

Determination of some physical and chemical properties of soil

Bulk density

The bulk density determination was done in three occasions using metallic cores (Blake and Hartage, 1986). Samples were taken before land preparation, at mid-season and at harvest. These undisturbed soil samples were taken in each plot at the depth of 0–10 cm, 20–30 cm and 30–50 cm using sampling cores. Bulk density was then calculated as the ratio of the dry mass of the soil to the core volume.

Organic matter determination

Composite soil samples were collected from each plot at harvesting time in June 2002 at 0–10 cm, 20–30 cm and 30–50 cm depth from each plot and air dried. Soil organic carbon was determined following the procedure described by Nelson and Sommers (1982). Soil organic matter was obtained by multiplying the percentage organic carbon by a factor of 1.72 as described by Nelson and Sommers (1982).

Determination of chemical properties of soil

In 2001/02 soil composite samples were collected from each treatment before land preparation to a depth of 20 cm from the soil surface. The soil was air dried, ground and sieved through a 2 mm sieve (Day, 1965). Soil chemical analyses were done in the Department of Soil Science at Sokoine University of Agriculture. Soil pH was measured potentiometrically in 1:2.5 soil water suspension following the procedure outlined by MacLean (1982). Organic carbon was determined by the wet oxidation method of Wakley-Black (Nelson and Sommers, 1982) and organic matter content of the soil at different depth was obtained by multiplying the

organic carbon content of the respective depths by multiplying the percentage organic carbon by a factor of 1.72 as described by Nelson and Sommers (1982). Total Nitrogen was determined by the semi-microkjedahl (Bremner and Mulvaney, 1982). Cation exchange capacity and exchangeable bases were determined by Neutral Ammonium Acetate extract and then Atomic absorption spectrophotometry (AAS) (Thomas, 1982). Bray and Kurtz (1945) method determined available phosphorus.

Yield components determination

At maturity, sorghum heads were cut using a sharp knife from a net area of 72 m² per plot in each treatment. Heads were air dried for five consecutive days to attain constant moisture content. To ensure uniform drying regular turning of the produce was done. Threshing was done using a tradition mortar and pestle. Immediately after winnowing sorghum grain yields from each plot were weighed using a common field balance. Yield weight was recorded accordingly.

Statistical analysis

Analysis of variance (ANOVA) was run for the measured soil and plant parameters using MSTATC. Version 4.0/EM and where significant differences were observed in treatments, the means were separated using New Duncan's Multiple Range Test at 0.05 probability level.

Results and discussion

Physico-chemical properties of the top (0–20 cm) of the experimental site

The physico-chemical properties of surface soil (0–20 cm) are given in Table 1. The bulk density was 1.60 Mg m⁻³. The soils are sand clay loam and therefore coarse textured, this property can reduce their capacity to retain nutrients against leaching. Because the experimental site was on a gentle slope (1–2%), soil erosion for the past many years might have contributed to the low fertility status of these soils. Deterioration of soil fertility is likely to have occurred due to continuous sorghum monocropping cultivation.

Table 3. Mean organic matter content in % as affected by different tillage methods in 2001/02 cropping season

Tillage methods	Farmyard manure (t/ha)	
	0	30
NT	0.52b	0.84a
STR	0.69b	0.70a
DTR	0.69b	0.63a
ADTR		0.82a
S.E \pm	0.08	
CV (%)	19.94	

NT = No-till, STR = Shallow depth of tillage with tie ridges, DTR = Deep depth of tillage with tie ridges, ADTR = Annual Deep depth of tillage with tie ridges. Means followed by the same letter along the same column are not significantly different at 5% probability level by Duncan New Multiple Range Test.

Effect of tillage methods on soil organic matter content

The results for 2001/02 cropping season soil organic matter (SOM) percentages are shown in Table 3. Tillage alone had no significant ($P>0.05$) effect on residual soil organic matter content. The NT, residual and annually ploughed tied ridges had no significant effect on residual soil organic matter content. At various depths the organic matter content at harvest was not significant ($P>0.05$) different among treatments (Table 4). The residual organic matter content decreased with depth 0–10 cm > 20–30 cm > 30–50 cm. The 0–10 cm depth had relatively higher organic matter content than 20–30 and 30–50 cm depths. However, according to

EUROCONSULT (1989) categorization of soil organic matter, the mean residual organic matter content of the experimental site was very low (<1.0%). It has decreased compared to that reported by Swai (1999) which ranged from 1.73 to 2.14%. And it is similar to that observed by Mwaliko (2001). Similar trend of SOM content decrease was reported by Ayanaba *et al.* (1976) and Tisdale *et al.* (1993). This may be due to continuous sorghum cultivation that has resulted into decreased SOM content in the study area over time.

Effect of tillage methods on sorghum grain yield

The sorghum grain yield as was affected by tillage methods is presented in Table 5. The control (NT) had significantly lower grain yield compared to other treatments. The annually made ridges (ADTR) had significantly ($P<0.05$) higher sorghum grain yield of 2.17 t ha⁻¹ compared to only 0.42 t ha⁻¹ in the control in 2001/02 cropping season. With and without application of FYM, sorghum grain yield was more than doubled under residual STR or DTR compared to the control (NT). Grain yield in all treatments with FYM was more than four times that in the control treatment (Fig. 1).

The higher yield observed in STR, DTR and ADTR were attributed primarily to the increase in soil water storage, which became available at critical period of the crop growth. In this regard, land configuration played an important role as it determined the retention time for rainwater to infiltrate into the soil.

Swai (1999) also observed high sorghum grain yields in residual and annually made tie ridges compared

Table 4. Mean organic matter content (%) at different depths as affected by different tillage methods at harvest

Tillage methods	Soil layer (cm)					
	0–10		20–30		30–50	
	Farmyard manure (t/ha)					
	0	30	0	30	0	30
NT	0.52b	1.02b	0.58a	0.62a	0.46a	0.90a
STR	0.75b	0.94b	0.68a	0.58a	0.65a	0.59a
DTR	0.93b	0.75b	0.65a	0.60a	0.51a	0.54a
ADTR		1.22a		0.73a		0.51a
S.E \pm	0.10		0.05		0.13	
CV (%)	21.59		15.74		20.21	

NT = No-till, STR = Shallow depth of tillage with tie ridges, DTR = Deep depth of tillage with tie ridges, ADTR = Annual Deep depth of tillage with tie ridges. Means followed by the same letter along the same column are not significantly different at 5% probability level by Duncan New Multiple Range Test.

Table 5. Sorghum grain yield as affected by tillage methods and FYM after five seasons

Treatments	Grain yield (t/ha)				
	*1996/97 (1 st season)	*1997/98 Residual tied-ridges (2 nd season)	*1998/99 Residual tied-ridges (3 rd season)	**1999/2000 Residual tied-ridges (4 th season)	2001/02 Residual tied-ridges (5 th season)
NT	0.51a	0.31a	1.65a	0.64b	0.42a
NT+F	1.25b	1.05b	1.72a		1.81b
STR	1.15ab	0.65a	2.41ab	1.49a	1.18b
DTR	1.49b	1.05b	3.11ab	1.69a	1.54b
STR+F	1.25b	1.20c	3.36b		1.84b
DTR+F	1.10ab	1.40c	3.48b		1.92a
ADTR+F	1.15ab	1.49c	2.93ab		2.17a

*Obtained from Rwehumbiza *et al.* (2000), and ** Mwaliko (2001). NT = No-till, NTF = NT+FYM, STR = Shallow depth of tillage with tie ridges without FYM, DTR = Deep depth of tillage with tie ridges without FYM, STRF = STR+ FYM, DTRF = DTR + FYM, ADTRF = Annual Deep depth of tillage with tie ridges with FYM. Treatments sharing the same letter in each season are not significantly different at P= 0.05. (FYM was applied once in the 1st season).

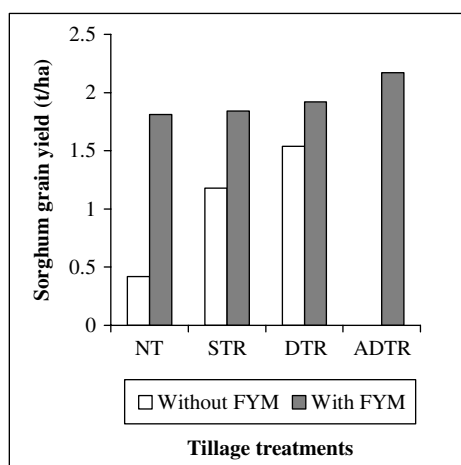

Figure 1. Sorghum grain yield as was affected by tillage treatments during 2001/02 season.

to the control (NT). This concurred with Clark and Jones (1981), MaCartney *et al.* (1971) and Vogel (1994) who attributed higher sorghum grain yields under tied ridges primarily to decreased runoff and consequently increased soil water storage.

The results are also in line with the findings of Rwehumbiza *et al.* (2000) and Mwaliko (2001) who, in previous seasons on the same experiment, reported higher sorghum grain yield in residual tied ridges than in the control (NT) and attributed this to increased soil water storage. Variability in grain yield between seasons is attributed to difference in the amount and distribution of rainfall.

Application of FYM even when no tillage was undertaken significantly increased sorghum grain yield compared to the control treatment (Swai and Rwehumbiza, 1998). FYM is known not only to improve soil water retention but also as a supplier of plant nutrients (Young, 1976; Kramer and Boyer, 1995). The 2001/02 results indicated that there were still benefits when using residual tied ridges up to five seasons without annual ploughing and reconstruction of tied ridges.

Conclusion

Tied ridges improved sorghum grain yield over the commonly used practices (No Tillage), benefits which was still observable five years after their establishment, in the semi-arid area of Hombolo Dodoma, Tanzania. Tied ridges have benefits not only in terms of crop yield but also in reduced labour.

Acknowledgements

The work reported in this paper was supported by the funds from the Norwegian Agency for Development Co-operation (NORAD) through the Department of Soil Science, Sokoine University of Agriculture (SUA), Morogoro Tanzania. Both NORAD and SUA are highly acknowledged. Also TSBF-CIAT-Nairobi is acknowledged for facilitating the publication of this paper.

References

- Anschütz J., Kome A., Nederlof M., de Neef R. and Van de Ven T. 1997. Water harvesting and soil moisture retention. *Agrodox Series No. 13*. 92 pp.
- Ayanaba A., Tuckwell A.B. and Jenkinson D.S. 1976. The effect of clearing and cropping on the organic residues and biomass of tropical forest soils. *Soil Biol. Biochem.* 8: 519–525.
- Blake G.R. and Hartage K.H. 1986. Bulk density. In: Klute A. (Ed.) *Methods of soil analysis part I. physical and mineralogy methods* 2nd edition. American Society of Agronomy, Madison, Wisconsin. pp. 363–375.
- Bray R.H. and Kurtz L.T. 1945. Determination of total organic and available forms of phosphorus in the soil. *Soil Sci.* 59: 39–45.
- Bremner J.M. and Mulvaney C.S. 1982. Total nitrogen. In: Page A.L., Miller R.H. and Keeney D.R. (Eds) *Methods of soil analysis part 2 chemical and microbiological properties* 2nd edition. Agronomy No. 9. American Society of Agronomy, Madison, Wisconsin, USA. pp. 595–622.
- Clark R.N. and Jones O.R. 1981. Furrow dams of conserving rainwater in semi-arid climate. In: *Proc. Am. Soc. Eng. Conf. On Crop Production with Conservation in the 80's*, Chicago, Illinois. pp. 12.
- Day P.R. 1965. Particle fractionation and particle size analysis. In: Evans D.D., White J.L., Ensminger L.E. and Clark F.E. (Eds) *Methods of soil analysis part I*. Madison USA. pp. 545–568.
- EUROCONSULT 1989. *Agricultural Compendium for Rural Development in the Tropics and Subtropics*. Elsevier Science Publishers B. V. Amsterdam, Netherlands. pp. 91.
- Georgis K. 2000. Conservation tillage research findings: the Ethiopian experience. In: Biamah E.K., Rockstrom J. and Okwach G.E. (Eds) *Conservation Tillage for Dryland Farming*. Technological options and experiences in Eastern and Southern Africa. Regional Land Management Unit (RELMA), Swedish International Development Cooperation Agency (Sida). Workshop Report No. 3. pp. 148–151.
- Hatibu N., Mahoo H.F., Kayombo B., Mbiha E., Senkondo E.M., Mwaseba D. and Ussiri D.A. 1995. Soil and Water Management in Semi-arid Tanzania Research Project. *Research News* 5 (2): 13–15.
- Kramer P.J. and Boyer J.S. 1995. *Water relations of plants and soils*. Academic Press, London. pp. 56.
- Land Resource Development Centre (LRDC) 1987. *Tanzania: Profile of Agricultural Potential*. NRI, London. 26 pp.
- MaCartney J.C., Northwood P.J. and Dawson R. 1971. The effect of different cultivation techniques on soil moisture conservation and the establishment and yield of maize at Kongwa, Central Tanzania. *Trop. Agric.* 48 (1): 9–24.
- MacLean A.J. and More F.R. 1979. *Manure and Composite*. Agriculture. Canada Publication. No. 868. Ottawa, Canada. Pp. 17.
- MacLean E.O. 1982. Soil pH and lime requirement. In: Page A.L., Miller R.H. and Keeney D.R. (Eds) *Methods of soil analysis part 2*. American Society of Agronomy, Madison, Wisconsin. pp. 199–224.
- Mahoo H.F. and Kaaya A.K. 1993. Characterization and Classification of Soils at Hombolo Experimental Site. *Soil Water Management in Semi-arid Tanzania*. Project Proceedings of the Planning Workshop. pp. 37–43.
- Mahoo H.F., Rwehumbiza F.B.R., Reuben S.S., Kayombo B., Hatibu N., Makungu P. and Ashimogo G. 1996. Improvement of the No-Primary Tillage (NPT) “kuberega” practice of sorghum-livestock-maize (SLIM) farming systems of semi-arid Tanzania: Rapid Rural Appraisal of Mpwapwa District. 21 pp.
- Mahoo H.F., Young M.D.B. and Mzirai O.B. 1999. Rainfall Variability and Its Implications for the Transferability of Experimental Results in the Semi-Arid Areas of Tanzania. *Tanzania J. Agri. Sci.* 2 (2): 127–140.
- Mwaliko R.B.M. 2001. *Effects of Residual Tied ridges on Soil physical factors and sorghum yield in semi arid Central Tanzania*. Unpublished Dissertation for Award of MSc. Degree at Sokoine University of Agriculture, Morogoro Tanzania. 87 pp.
- Nelson D.W. and Sommers L.E. 1982. Total Carbon, Organic carbon and Organic matter. In: Page A.L. (Eds) *Methods of soil analysis Part 2. Chemical and Microbiological Properties*. pp. 539–579.
- Reuben S.O.W.M., Rwehumbiza F.B.R., Mahoo H.F., Hatibu N., Ashimogo G.C. and Makungu P. 1998. Paths of influence among components of yield in sorghum (*Sorghum bicolor* L. Moench) grown in the semi-arid Dodoma region, Tanzania. *Tanzania J. Agric. Sci.* 1 (2): 16–24.
- Rwehumbiza F.B.R., Mahoo H.F., Hatibu N., Reuben S.O.W.M., Makungu J.J. and Ashimogo G.C. 2000. Tied-ridging as a Rainwater Harvesting Technique. Experience from Hombolo, Dodoma, Tanzania. In: Matovelo J.A., Luzi-Kihupi A., Monela G.C. and Mgasa M.N. (Eds) *Proceedings of the first University-wide Scientific Conference*. 5–7 April 2000, Morogoro Tanzania. pp. 172–178.
- Swai E.Y. 1999. Effect of Residual Tie-ridging and Farmyard manure Application on Soil Water Status and yield of Sorghum in Semi arid areas. A case study in Hombolo, Dodoma-Tanzania. Unpublished Dissertation for Award of MSc. Degree at Sokoine University of Agriculture, Morogoro, Tanzania. 135 pp.
- Swai E.Y. and Rwehumbiza F.B.R. 1998. Effects of residual tie-ridging and farm yard manure on soil water storage in Central semi-arid areas of Tanzania. *Proc. Tanzania Soc. Agric. Eng.* 8: 7–19.
- Thomas G.W. 1982. Exchangeable cations. In: Page A.L., Miller R.H. and Keeney D.R. (Eds) *Methods of soil analysis part 2* 2nd edition. American Society of Agronomy, Soil Science Society of America Monograph No. 9. Madison, Wisconsin, USA. pp. 155–165.
- Tisdale J.M. and Oades J.M. 1982. Organic matter and water stable aggregates in soil. *J. Soil Sci.* 33: 141–163.
- Tisdale S.L., Nelson L.N., Beaton J.D. and Havlin J.L. 1993. *Soil fertility and fertilizers* 5th edition. Prentice-Hall, Simon & Schuster/A Viacom Company. Upper Saddle River, New Jersey. 634 pp.
- Vogel H. 1994. *Conservation Tillage in Zimbabwe*. Evaluation of Several Techniques for the Development of Sustainable Crop Production systems in Smallholder Farming. Geographical Bernensia and Geographical Society Berne. University of Berne Switzerland. pp. 150.
- Young A. 1976. *Tropical Soils and Soil Survey*. Cambridge University Press, Cambridge. 467 pp.

Evaluation of *Gliricidia sepium*, *Casuarina junghuhniana* and *Faidherbia albida* tree species for improvement of crop production and fuelwood supply in Muheza districts, Tanzania

Joel L. Meliyo, Marandu A.E.T. and Munuo E.

ARI-Mlingano, P.O. Box 5088, Tanga, Tel: +255 26 27 47647 E-mail: mlingano@iwayafrica.com or jlmeliyo@yahoo.co.uk

Abstract

A study was conducted in Muheza district to evaluate *Gliricidia sepium*, *Casuarina junghuhniana* and *Faidherbia albida* for adaptability, potential to improve crop production and firewood supply. The experimental was complete randomised block design (CRBD) in a factorial arrangement, replicated three times. Two types of management practices were applied coppicing and pollarding. Results show that survival rates were dependent on trees species and management type. Pollarding was superior to coppicing. The survival rates for *G. sepium* were 100 and 98% for pollarding and coppicing respectively. It was 73 and 58% for *F. albida*, 58 and 50% for *C. junghuhniana* for pollarding and coppicing. Leaf biomass was dependent on trees species and management practices. *G. sepium* had leaf biomass of 1.02 and 2.18 t ha⁻¹ for coppicing and pollarding, and is equivalent to addition of 33.7 kg N, and 72 kg N ha⁻¹ year⁻¹ into the soil respectively. Woody biomass for *G. sepium* was 20.7 t ha⁻¹ and 11.6 t ha⁻¹ per year for pollarding and coppicing, respectively. Thus *G. sepium* appeared more adapted to the area than *F. albida* and *C. junghuhniana*. Yield levels were not significantly different from the control most probably because of erratic rains received during the time of experimentation

Key words: adaptability, coppicing, crop production, fuelwood supply, pollarding

Introduction

Decline in crop yields has been a major problem facing smallholder farmer in Tanzania (Mowo et al. 1993; Nyadzi 2004). This is attributed to low soil fertility caused by continuous removal of nutrients through harvesting of grains and crop residues from crop land without adequate replenishment through external inputs such as fertilisers. Other poor environment management practices such as deforestation, bush fires resulted to severe natural resources degradation manifested by erosion, reduced soil organic matter, and destroyed soil structure which ultimately leads to reduced soil productivity. The common staple food, maize yields are as low as 1.4 ton ha⁻¹ as compared to the potential yields that are 4 tons ha⁻¹ (Mowo et al. 1993). The low yields have led to frequent food shortages in most areas of the

country, as it's the case in most sub-Saharan African countries. This phenomenon has been described to be an agricultural crisis in Sub Saharan Africa (Pol 1992). Soil productivity could be improved through application of fertilisers, but external inputs such, as chemical fertilisers are beyond reach by resource poor farmers.

Inadequate supply of fuelwood is another great concern, whereby women and school-aged children spend many hours looking for fuelwood. That has resulted to enormous pressure on pockets of natural forests. A participatory rural appraisal (PRA) conducted in Maramba, one of Muheza divisions, indicated that fuelwood shortage is forcing farmers to use perennials crops such mangoes and cashew nut for charcoal burning (Meliyo et al. 2002). It is argued therefore, that agroforestry technologies offer the best alternative for improving, maintaining soil fertility and for

providing both firewood and wood products (Cooper and Denning 1999; Kwapata et al. 1990; Bunderson et al. 1990). For example use of prunings from *Gliricidia sepium* has been reported to increase maize yields (Ikerra et al. 1998). Magembe (1994) reported an increase of maize yield from 1 to 4 t ha⁻¹ in Malawi from an intercrop of maize and gliricidia. There are many similar studies, which indicate yield increases from improved fallow and or relay cropping whereby leaves are incorporated or trees fix nitrogen that benefits subsequent crops (Karachi et al. 1997; Otsyina et al. 1997).

Research on agroforestry has been conducted in Tanzania for a long time since 1970s (Ngatunga et al. 1994). However, the actual practice of the technologies is still minimal and data shortage is common when come to specific areas of the country. There is a general inadequate knowledge on adaptation and potential supply of nutrient and fuel wood of different MPTs that are used by farmers.

This project was formulated to evaluate three multipurpose tree (MPTs) species namely *Gliricidia sepium*, *Casuarina junghuhniana* and *Faidherbia albida* for their adaptability, potential to improve and maintain soil fertility and their potential in providing fuel wood.

Methodology

Site characteristics

The study area is located in a farmer's field in Muheza district, at Longitudes 39° 52' E and Latitudes 5° 10' S at the altitude of 150 metres above sea level. The area receives an annual rainfall of 800 to 1000 mm and temperatures range from 24 to 30°C. The soils are clayey, characterised by low Nitrogen (0.14%), Phosphorus (3.28 mg kg⁻¹) and Potassium (0.32 cmol(+) kg⁻¹). The soil is also alkaline with high exchangeable Calcium (15.4 cmol(+)Ca kg⁻¹) and Magnesium (4.2 cmol(+) kg⁻¹). The soil has high pH (7.7) and high organic matter (OC 2.9%).

Treatments and experimental design

The experiment comprised of eight treatments arranged in a Complete Randomised Block design with three replication. Two treatments were monocropped maize without and with 50 kg N ha⁻¹. Six treatments were intercropped with *Gliricidia sepium*, *Casuarina*

junghuhniana and *Faidherbia albida* MPTs each under coppicing and pollarding management practices.

The plots size for the monocropped maize was 5 m × 18 m. Maize was planted at a spacing of 0.75 m × 0.3. The plot sizes for intercropped plots were 18 × 18 m with trees at 6 m × 6 m with maize plants in between the rows.

Three MPTs were planted 2000 with a spacing of 6m × 6 m and the planting holes were 0.6 m × 0.6 m. A test crop was maize a variety TMV1 planted at a spacing of 0.30 m × 0.75 m. The maize crop was planted between tree lines. A phosphorus fertiliser was applied as basal dose at the rate of 20 kg P ha⁻¹ at planting and three quarters of nitrogen (37 kg) fertilisers was applied to maize under inter crop, the remaining was assumed to come from the MPTs.

Data on survival rates diseases and pest scores were annually collected. Third year after establishment of trees species two management practices which were coppicing and pollarding were introduced. Coppicing involved cutting a whole tree about 30 cm from the ground. Leaves were separated from the branches, both components were weighed fresh and some known samples for leaf and wood were collected for oven drying at 70 °C to constant weights. Then remaining leaves were spread on respective plots and incorporated with a hand hoe. Branches were sun dried and used as fuelwood. Another management practice pollarding involved cutting of leaves and tips (twigs) of branches. The leaves were weighed and incorporated.

Data collection and analysis

Survival rate counts growth parameters (diameters, height) and crop yield were collected annually and analysed. Whole plots were harvested. Information available in databases on nutrient contents of leaves and twigs was used to estimate the potential amounts of nutrients that can be obtained from the biomass produced by the leguminous. All the data were analysed using Mstat C program and mean were separated by Duncan Multiple Range Test.

Results

Establishment and adaptability of tree species

Establishment and adaptability of MPTs was assessed by monitoring the survival rate which revealed the

Table 1. Survival rates (%) of three tree species in Muheza district in Tanzania

Treatment	2001	2002	Second year after management
<i>Gliricidia sepium</i> pollarded	94a	94a	100
<i>Gliricidia sepium</i> coppiced			98
<i>Faidherbia albida</i> pollarded	88b	86b	73
<i>Faidherbia albida</i> coppiced			54
<i>Casuarina junghuhniana</i> pollarded	65c	64c	58
<i>Casuarina junghuhniana</i> coppiced			50

G. sepium tree species survived second year after treatment because all coppiced. There were significant difference between tree species and different management practices.

highest rate in *G. sepium* whereas *C. junghuhniana* had the lowest survival rate. The survival rate of this latest species was not statistically different from that of *F. albida* three years after planting (Table 1). Coppicing reduced the survival rate compared to pollarding. The adaptability of three species was also evaluated by measurements on growth rate: heights, collar diameter and Diameter at Breast Height (DBH). Table 2 presents statistical analysis of heights and diameters of evaluated trees in three years. In general, height of seedlings before transplanting was less than 1 m, i.e. 0.75 m, 0.71 m and 0.38 m for *G. sepium*, *C. junghuhniana* and *F. albida*, respectively. Three years after planting the height values were in the same order of *G. sepium* > *C. junghuhniana* > *F. albida* even though the difference was only statistically significant between *G. sepium*

and *F. albida* (Table 2). Collar diameter followed similar trends to tree height parameter whereas the three species were statistically different for the DBH with again *G. sepium* showing the largest diameter followed by *C. junghuhniana* and *F. albida* (Table 2).

Biomass yield and Nutrient content

The average biomass yield and nutrient contents of the evaluated trees are presented in Table 3. *G. sepium* under pollarding and coppicing produced 2.18 and 1.02 t ha⁻¹ of leaf biomass respectively which is equivalent to 71.94 and 33.66 kg N ha⁻¹ if the leaves are applied to decompose and all the contents of nutrients released. *C. junghuhniana* yielded 0.26 and 0.71 t ha⁻¹ of leaf biomass under pollarding and coppicing management and *F. albida* yielded 0.51 and 0.38 t ha⁻¹ when coppiced and pollarded, respectively (Table 3).

Results also indicated that pollarding provided more fuel wood than coppicing in *G. sepium* with respectively 20.7 and 11.6 t ha⁻¹ of dry wood annually. A higher production of fuelwood by *G. sepium* is due to a vigorous branching and coppicing after the cutting/pruning practice. Pollarded stands normally had branches ranging from 35 and 50 while coppicing had branches ranging between 11 and 35 per individual. The data further indicated that pollarding could not be done for *F. albida* and *C. junghuhniana* simply because they had no leaves because the species have reverse phenology (Roupsard et al. 1998; Wood 1989). This is an added advantage because the trees do not complete light with annual crops. Coppiced *C. junghuhniana* regenerated very slowly and 20% of coppiced plants dried suggesting that coppicing is not a very good management practice for this species at this locality.

Table 2. Comparison of means height and diameters of the multipurpose trees in Muheza district in Tanzania

Tree species	Height (M)			Root collar diameter(cm)		Breast height diameter(cm)	
	2000	2001	2002	2001	2002	2001	2002
<i>G. sepium</i>	1.5	3.2a	3.65a	5.7a	21.9a	3.4a	12.1a
<i>C. junghuhniana</i>	1.2	2.8a	3.22ab	3.5b	13.6ab	1.8b	6.6b
<i>F. albida</i>	0.5	1.2b	2.04b	2.6b	10b	na	4.2
CV%	nd	13.18	15.24	14.7	18.33	17.1	18.3

nd = not determined; Statistical analysis was not done during planting. Figures followed by the same letter in the same column are not significantly different at 5% according to Duncan Multiple Range test.

Table 3. Biomass and estimated nutrient inputs from leaves of three MPTs for 2003 season in Muheza district in Tanzania

Treatment 2003	Mean weight in t/ha 2003		Estimated nutrient inputs from decomposed leaves(kg ha ⁻¹)		
	Branches	Leaves	N	P	K
<i>G. sepium</i> pollarded	20.7	2.18	71.94	4.36	45.78
<i>G. sepium</i> coppiced	11.6	1.02	33.66	2.04	21.42
<i>C. junghuhniiana</i> pollarded	–	0.26	–	–	–
<i>C. junghuhniiana</i> coppiced	5.4	0.71	–	–	–
<i>F. albida</i> pollarded	–	0.38	–	–	–
<i>F. albida</i> coppiced	1.8	0.51	–	–	–
CV %	79.09	104.4			

Also, although, pollarding regenerate slowly such trees do not dry.

Maize yields as influenced by tree species

The first two seasons gave higher yields in crop production than the third season because of drought in 2002. In general, the rest of the treatments tended to produce better compared to the control. However, there were no significant statistical differences between treatments during the three years of monitoring (Table 4).

Discussion

The results indicated that the evaluated tree species are suited to the area in the order of survival as followed *G. sepium* > *F. albida* > *C. junghuhniiana*. Most of the *F. albida* were growing at smaller rate compared to the rest while *C. junghuhniiana* grew relatively fast but with low survival rates compared to the other two species. Thus, *G. sepium* appeared to be best in terms

of adaptability and fuelwood production at this stage. *C. junghuhniiana*, despite a poor survival rate, gave cuttings that were useful as source of fuelwood. As both *G. sepium* and *C. junghuhniiana* coppice easily this can be good wood materials in many areas where there are problems of firewood. From the results there are up to 4.3 tones ha⁻¹ of dried wood that can be used as source of energy to serve forest encroachment and to serve firewood collectors from going long distances. There are also clear indication (height, diameter, straightness) that *C. junghuhniiana* and *F. albida* will in future make good building poles.

Fresh leaves of pollarding and coppicing management's practices obtained from *G. sepium* were spread in respective plots. *C. junghuhniiana* also gave reasonable amounts of leave biomass (Table 3). According to the established facts *G. sepium* leaves contains between 3.5 to 4.5%N (Palm et al. 2001). This means by adding 0.76 t ha⁻¹ and 1.26 t ha⁻¹ of leaves will potentially be equivalent to 27 kg N ha⁻¹ and 44 kg N ha⁻¹ for the first year of pruning if all contents of nutrients are released by decomposition. This amount may increase with increase tree growth, with the implication of

Table 4. Maize yields across seasons 2000 to 2002 in Muheza district in Tanzania

Treatments	Grain yield in kg ha ⁻¹		
	2000	2001	2002
Control	1433	2078	809
Maize + <i>Gliricidia sepium</i> coppiced	2694	2434	1073
Maize + <i>Casuarina junghuhniiana</i> coppiced	2514	2534	992
Maize + <i>Faidherbia albida</i> coppiced	2480	2226	1333
Maize + <i>Gliricidia sepium</i> pollarded	3166	2405	827
Maize + <i>Casuarina junghuhniiana</i> pollarded	2514	2115	1274
Maize + <i>Faidherbia albida</i> pollarded	2942	2414	1250
Maize + 50kg N ha ⁻¹	2983	3108	1093
C.V %	13.9	22.6	38

adding more nutrients through recycling. Plots planted with *F. albida* require another method to evaluate the quantity of leaves shed because at pruning period the individuals are leafless due to their reverse phenology (Roupsard et al. 1998; Wood 1989). However, it has been reported that *F. albida* adds N in the system through N-fixation (Palm et al. 2001). Wood (1989) reported that in West Africa apart from N-fixation *F. albida* also improves soil properties such as physical, chemical and biological. As pollarding was impossible for this species because of its reverse phenology (Wood 1989) while coppicing reduced the survival rate, it can be concluded that none of these two management practices was appropriate for *F. albida*.

There was no significant difference of yields between treatments during the first year of leaf incorporation (Table 4) even though it has been reported that *G. sepium* leaves applied improved soil N and then increased maize yields in Malawi (Ikerra et al. 1998). Furthermore, farmers' assessment indicated that plots where *F. albida* flourished well had good maize crop compared to control and even to other treatment plots.

Conclusions

From the results of the present study we can conclude that *G. sepium* was well adapted to the area than the other two tree species. Also, Survival rates are higher for all pollardings practices than coppicings, which suggest that pollarding is a more favourable management practice than coppicing, in particular to *C. junghuhniana* and *F. albida*. Although there was no statistically notable yield differences from the control, leaves incorporation of *G. sepium* in the fields could add substantial amounts of N, P and K and in the systems. It could provide wood materials that were needed by communities for energy and other uses. However, more time is required to study more about the influence of these tree species on soil properties and also to quantify the polyphenol contents of their materials and their influences on nutrient release patterns.

Acknowledgement

We are grateful to TARPII project for providing funds that enabled the study to be done. Thanks to the ARI-Mlingano management for backstopping and all

facilitation. We appreciate the support for field activities done by field officers and the farmer. TSBF for supporting all logistics that enable me attending in this conference and presenting this work to you I also acknowledge your attention for listening me. God blesses you.

References

- Bunderson W.T., Saka A.R., Itimu O.A., Mbekeani Y. and Phombeya H.S.K. 1990. Effects of *Acacia albida* on maize (*Zea mays L.*) grain yields under traditional management in Malawi. In: Saka A.R., Bunderson W.T. and Magembe J.A. (Eds) Agroforestry research and development in Malawi. Proceedings of the First National Agroforestry Symposium on Agroforestry Research and Development Held at Bvumbwe Agricultural Research Station, Limbe, Malawi, November 4–10. pp. 207–219.
- Cooper P.J.M. and Denning G.L. 1999. *Scaling up the impact of agroforestry research*. Report of the Agroforestry Dissemination Workshop 14–15 September 1999, Nairobi, Kenya.
- Ikerra S.T., Smithson P.C., Magembe J.A. and Buresh R.J. 1998. Soil organic dynamics and maize yields in a *Gliricidia sepium*-maize intercrop in Southern Malawi. Maize production Technology for the future: Challenges and opportunities. Proceedings of the Sixth Eastern and Southern African Regional Maize Conference, Held in Addis Ababa, Ethiopia 21–25 September 1998.
- Karachi M., Shirima D. and Lema N. 1997. Evaluation of 15 leguminous trees and shrubs for forage and wood production in Tanzania. *Agroforestry Systems* 37: 253–263.
- Kwapata M.B., Chiyenda S.S. and Kanyama-Phiri G.Y. 1990. Maize yield response under alley cropping. In: Saka A.R., Bunderson W.T. and Magembe J.A. (Eds) Agroforestry research and development in Malawi. Proceedings of the First National Agroforestry Symposium on Agroforestry Research and Development Held at Bvumbwe Agricultural Research Station, Limbe, Malawi, November 4–10. pp. 189–196.
- Magembe J. 1994. Focus on Agroforestry research in the miombo ecozone. In: Ngatunga E.L., Gama B.M. and Lutkam M. (Eds) *Agroforestry and Environment in Tanzania*. Ministry of Agriculture and Ministry of Tourism, Natural Resources and Environment. pp. 30–31
- Meliyo J.L., Mndolwa S.I., Babu A.K., Kaganda S.R., Ringo D.E., Hussein S.S., Ruheta M., Kimbi E.C., Mduruma Z.O., Nsemwa L.T.H. and Mongi R. 2002. A Participatory Rural Appraisal (PRA), Mbambakofi, Maramba Divison, Muheza District, Tanga.
- Mowo G.J., Floor J., Kaihura F.B.S. and Magoggo J.P. 1993. Review of Fertilizer Recommendations in Tanzania. Part 2, Revised Fertilizers Recommendations for Tanzania, National Soil Service, ARI-Mlingano, Tanga.
- Ngatunga E.L., Gama B.M. and Lutkam M. 1994. *Agroforestry and Environment in Tanzania*. Summary of Proceedings of the First Tanzania National Agroforestry and Environment Workshop. Ministry of Agriculture and Ministry of Tourism and Natural Resources and Environment.
- Nyadzi, G.I. 2004. Nutrient and water dynamics in rotational woodlots. A case study in western Tanzania. Ph.D. Thesis. Wageningen

- University and Research Centre, Wageningen, The Netherlands. pp. 192.
- Otsyina R., Msangi R., Gama B.M., Ramadhani T., Nyadzi G. and Shirima D. 1997. SADC/ICRAF Agroforestry Project Tumbi, Tabora, Tanzania. Annual Progress Report No. 114. ICRAF, Nairobi, Kenya.
- Palm C.A., Gachengo C.N., Delve R.J., Cadisch G. and Giller K.E. 2001. Organic inputs for soil fertility management in tropical agroecosystems: application of an organic resource database, *Agric. Ecosyst. Environ.* 83: 27–42.
- Pol F. van der 1992. Soil mining unseen contributor to farm income in southern Mali. KIT bulletin 325.
- Roupsard O., Joly H.I. and Dreyer E. 1998. Variability of initial growth, water-use efficiency and carbon discrimination in seedlings of *Faidherbia albida* (Del.) A. Chev., a multipurpose tree of semi-arid Africa. Provenance and drought effects. *Annales des Sciences Forestières* 55: 329–348.
- Wood P.J. 1989. *Faidherbia albida* (Del.) A. Chev. (Synonym: *Acacia albida* Del.). A monograph. Technical Centre for Agricultural and Rural Cooperation, AJ Wageningen (Netherlands).

Mineral N distribution in the soil profile of a maize field amended with cattle manure and mineral N under humid sub-tropical conditions

Nyamangara J.

Department of Soil Science and Agricultural Engineering, University of Zimbabwe, P. O. Box MP167, Mount Pleasant Harare, Zimbabwe; Email: jnyamangara@agric.uz.ac.zw

Abstract

Fluctuations in the concentration of soil mineral N in sub-Saharan Africa mainly reflect the net effect of inputs from mineralisation and fertilizer inputs, and removal by plant uptake, immobilization, leaching and gaseous losses. A 3-yr study was conducted to monitor the temporal variation in mineral N in the soil profile of a maize field amended with cattle manure (0, 12.5 t ha⁻¹yr⁻¹ and 37.5 t ha⁻¹ only applied in the first year) and mineral N fertilizer (0, 60, 120 kg ha⁻¹). Soil auger samples were taken periodically from 4 weeks after planting (WAP) until harvesting to a depth of 1000 mm. Generally, mineral N was highest in the mineral N and mineral N plus manure treatments (up to 60 mg kg⁻¹) with most of the N, concentrated in the top soil, and was lowest in the control and manure treatments (<20 mg kg⁻¹). Nitrogen uptake in the manure treatments was also depressed compared to mineral N treatments or manure plus mineral N treatments. Mineral N concentration decreased as the season progressed mainly due to plant uptake, and also there was a decrease from the first to the third season which was attributed to decreased contribution from the previously grass fallow to soil mineral N. There was a partial immobilization of mineral N fertilizer by the aerobically composted manure when the two N sources were applied in combination but it was of limited practical importance in reducing N leaching where relatively high rates of mineral N are applied. There was evidence of mineral N movement in the subsoil early in the season (4–6 WAP) when mineral N was applied. It was concluded that there is need to supplement aerobically composted cattle manure with some mineral N in order to prevent N deficiency during the early part of the season. Maize N uptake efficiency in smallholder farming areas can usefully be enhanced by applying mineral N fertilizer at planting at a lower rate (e.g. 10–20 kg N ha⁻¹) than the recommended 30% (>30 kg N ha⁻¹) of N requirement, with the balance being split-applied during the season as crop demand increases

Key words: cattle manure, KCl-extractable N, N leaching, mineral N

Introduction

Nitrogen is the key factor in crop productivity and often the limiting factor to crop growth in smallholder farming systems in Sub-Saharan Africa (SSA) (Sanchez et al. 1997). Animal manure is used as the main source of N (and other nutrients) in most cropping systems in SSA, and in Zimbabwe cattle manure is the major organic fertilizer. Although mineral fertilizers are used,

the relative prices of fertilizers and produce limit the amount of fertilizer that smallholder farmers apply to their crops.

Although cattle manure available to the farmers are inadequate, farmers tend to apply large amounts to certain preferred fields resulting in high application rates. In the Alvord system recommended for the Zimbabwean smallholder farmers since the 1960s, 30–40 t ha⁻¹ of cattle manure was applied to maize in a

4-course rotation of two maize crops, followed by a legume and then a small grain crop (Grant 1976). The high application rates imply that the total N loading is much greater than crop requirement and depending on the N mineralisation pattern from the manure, excessive N availability may occur. Coupled with the predominantly coarse sandy soils in smallholder areas (Grant 1981) and high intensity rainfall pattern characteristic of tropical areas, the potential for N leaching in fields amended with high rates of manure is high. Nitrogen leaching constitutes both economic and environmental concern. Smallholder farmers are more concerned about economic losses because of their poor resource base.

Manure contains both mineral N that is readily available and organic N that has first to be mineralized before it becomes available. Jokela (1992) reported from the USA that the effect of farm yard manure on crop yield was greatest in the second or third year compared to the first year implying high N mineralisation rates in the second and third years. The cattle manure from smallholder areas in Zimbabwe is often of low quality (ave. <1% N) and this is mainly due to inadequate and poor quality grazing (Mugwira and Mukumbira 1984), contamination with soil (Nhamo 2003; Nyamangara et al. 1999) and poor handling and storage methods (Khombe et al. 1992; Nzuma et al. 1998). The manures, which are aerobically composted, immobilize or slowly mineralize N resulting in N deficiency during early plant growth (Murwira and Kirchmann 1993; Nhamo 2003).

Nitrogen from mineral fertilizer is immediately available for plant uptake but it is susceptible to loss through leaching or gaseous losses. Excessive losses occur when mineral N is applied in excess of crop demand or when timing and method of application are wrong. Vogel et al. (1994) reported that up to 54% of the fertilizer N applied to a maize field at an agricultural site in Zimbabwe was leached out of the plough layer (0–500 mm) when heavy rains were preceded by N fertilizer application. Kamukondiwa and Bergström (1994) reported N leaching losses of up to 39 kg N ha⁻¹ yr⁻¹ in summer (maize) and 18.6 kg N ha⁻¹ yr⁻¹ in winter (wheat under irrigation) on a deeply weathered sandy soil at Grasslands Research Station, Zimbabwe, in a study that was carried out during a sequence of very dry years. This implies that N leaching potential will be higher in normal rainfall years.

Fluctuations in the concentration of soil mineral N reflect the net effects of inputs from mineralisation,

atmospheric deposition and fertilizer inputs, and removal by plant uptake, immobilization, leaching and gaseous losses. Therefore factors which affect the above process, e.g. temperature, moisture and soil type, also affect the concentration and distribution of mineral N in the soil profile. In most tropical and subtropical environments, temperature variations are limited and microbial N turnover is continuous unless when moisture is limiting, and moisture is also a medium for N leaching (Wong and Nortcliff 1995). The movement of mineral N in the soil is mainly governed by mass flow in moving soil solution and diffusion within the soil solution (Jury and Nielsen 1988). However, preferential (macropore) flow results in rapid movement of mineral N to deeper soil horizons (Roth and Fox 1990).

Mineralisation of N from high organic matter soils can result in higher mineral N accumulation in the soil profile compared to low organic matter soils. The highest concentration of native mineral N occurs during the transition between dry and wet seasons, and is often manifested by a flush in mineral at the inception of the first rains (Wong and Nortcliff 1995). Increased N mineralization (and hence N accumulation) after drying and wetting of the soil is attributed to increased substrate availability from death of microbial biomass and from physical disruption of the soil thereby exposing physically protected organic matter (Groffmann and Tiedje 1988). The organic matter content of most soils in the smallholder areas of Zimbabwe is very low (0.4–0.8% C) (Mugwira et al. 1992) and therefore the effect of N mineralisation from native organic matter on N accumulation in the soil profile is limited.

The assessment of the agronomic effectiveness of the manure and mineral fertilizer in Zimbabwe has been based mainly on plant uptake (Mugwira and Mukumbira 1984; Murwira and Kirchmann 1993; Nhamo 2003), and there is a paucity of information on the effect of these nutrient sources on N movement in the soil profile. Excess availability at any time during plant growth can result in N leaching, although some of the leached N can move up in the rooting zone due to capillarity. This study was designed to determine the effect of rate of cattle manure and N fertilizer, applied singly or in combination, on N movement in the soil profile of a maize field. It was hypothesized that N leaching risk from manure treatments was highest in the second and third years when organic N becomes available, and the risk from mineral N fertilizer was highest soon after application.

Methods and materials

Study site

The field site was located at Domboshawa Training Centre (DTC) (17° 35'S, 31° 10'E; elevation 1550 m), about 35 km north of Harare, Zimbabwe. The site had been under a grazed grass fallow for at least six years. The climate at DTC is characterised by hot wet summers and cool dry winters. Long-term rainfall records (50 yrs) at the site show that the average rainfall is 879.6 mm (28% coefficient of variation), 95% of it during the summer season (November–April), and the mean temperature for the site is 18.8 °C (Department of Meteorological Services 1977). Relative humidity during the summer season ranges from 83% in the morning (0800 hrs) to 42% in the afternoon (1400 hrs), and generally is highest in February. Rates of evaporation during the growing season vary from 6 mm day⁻¹ in November to 4.7 mm day⁻¹ in April (Department of Meteorological Services 1981).

The soil at the experimental site was a relatively highly weathered and leached coarse grained loamy sand derived from granodiorite gneiss and classified as a Typic Kandiuustalf (Nyamapfene 1991). The soil has relatively low available water capacity (9% vol.) and is susceptible to formation of a perched water table in high rainfall years (Vogel 1992; Vogel et al. 1994), despite high infiltration rates (ca. 200 mm h⁻¹) characteristic of the soils (Twomlow 1994). Bulk densities are variable (1.5–1.7 Mg m⁻³) and on drying the soils are hardsetting (up to 3000 kPa penetration resistance) (Vogel 1992). Vogel (1992) also reported maximum maize rooting depth of 500 mm in a tillage experiment conducted near the site of this study.

Experimental design and layout

The manure used in the 3-year study was aerobically composted and had a total N content of 0.93% and organic C content of 8.4% (C-to-N = 9). Three manure rates (0, 12.5 t ha⁻¹ annum⁻¹, 37.5 t ha⁻¹ first year application) and three N fertilizer rates (0, 60, 120 kg N ha⁻¹ annum⁻¹ as NH₄NO₃) were used in a 2-factor randomised complete block design with three replications. The plot sizes were 6 m by 5 m. Nitrogen fertilizer was applied in three equal split applications at planting, 6 and 12 weeks after planting (WAP). The manure was evenly broadcast onto the respective plots.

A basal application of S and P as single super phosphate (8.1% P and 12% S), and K as muriate of potash

(49.8% K) was applied to all the treatments to give 19.5 kg P, 30 kg K and 30 kg S ha⁻¹. The manure and basal fertilizer applications were incorporated into the plough layer (200 mm) of the soil using a hand-hoe. Planting furrows were marked out soon after incorporation of manure and basal fertilizer. A third of the N fertilizer was banded into the planting furrows and partially covered with soil before maize (*Zea mays* L.) (local variety R215) was planted at a target population of 41 667 plants per ha. Weeds were controlled by hand-hoeing through out the season. The remaining N fertilizer was banded along the planting rows (intra-row on one side of the plants in two equal split applications at 6 and 12 WAP). At the beginning of the second and third seasons, aboveground maize stover was removed before ploughing to simulate smallholder farming systems in Zimbabwe where stover is collected and fed to cattle during winter when grazing is scarce. Rainfall was recorded throughout the growing season using a rain gauge.

Soil and plant sampling and analysis

Three replicate auger samples were taken at 4, 6 and 12 WAP, and at harvesting to determine available N distribution in the soil profile. The auger samples were taken at 0–200, 200–300, 300–400, 400–500, 500–700 and 700–1000 mm soil layers. Three auger subsamples from corresponding horizons, e.g. 0–200 mm, were thoroughly mixed to constitute one composite soil sample. Three auger sub-samples were deemed adequate given the relatively small size of the experimental plots. Two maize plants near the auger positions were also sampled for determination of dry matter yield and total N uptake. Sampling was limited to the three outer rows on either sides of the plot in a structured manner so that the net plot in the centre of each plot was not affected and used for total N uptake and yield determination. At 6 and 12 WAP, soil and plant sampling were done just before application of mineral N fertilizer.

The soil samples were air dried, crushed and passed through a 2 mm sieve. Available N (NH₄ + NO₃⁻) was extracted by intermittently shaking the soil in 0.1 M KCl suspension for 30 minutes and filtering (Saunders et al. 1957). A distillation method employing a Cu catalyst (Devarda's alloy) to convert NO₃-N to NH₄-N was used before colour was developed using Nessler's reagent (Keeney and Nelson 1982). The concentration of the extracted N was read using a spectrophotometer.

Plant samples were rinsed in distilled water, oven-dried at 65 °C and dry matter yield determined. The

Table 1. Chemical and physical properties of the experimental soil

Soil depth (mm)	pH(CaCl ₂)	Organic C(%)	Total N (%)	C-to-N ratio	KCl-N (mg kg ⁻¹)	Clay (%)	Silt (%)	Fine sand (%)	Medium sand (%)	Coarse sand (%)	Bulk density (Mg m ⁻³)
0-100	4.7	0.40	0.030	13.3	23	5	3	17	51	24	1625
100-270	4.7	0.17	0.015	11.3	21	6	3	17	50	24	1620
270-400	4.6	0.13	0.012	10.8	17	10	3	16	48	23	
400-700	4.5	0.13	0.013	10.0	16	18	3	15	39	25	
700-1300	4.6	0.08	0.009	8.9	17	30	2	13	37	18	

NB. Soil depths depict pedological horizons identified during site characterisation.

air-dried samples were ground to pass through a 2-mm sieve and analysed for N content using the semi-micro Kjeldahl method (Bremner and Mulvaney 1982).

The effect of manure and N fertilizer application on N uptake and KCl-extractable N in the soil profiles of the different treatments was analysed using a two factor analysis of variance (ANOVA) procedure with the treatments as main plots and soil depth as subplots of the treatments.

Results

Soil, crop and weather conditions

Table 1 shows selected properties of the experimental soil. Generally, the soil was slightly acidic and had a low organic C content. Rainfall during the first (865 mm) and third (840 mm) cropping seasons was within the average for the area, but the second season was wetter (1395 mm). Rainfall intensity during the first and second seasons was high (up to 120 mm day⁻¹), and in the third season the intensity was relatively low and periods of moisture stress were experienced (Figure 1). The relatively long grass fallow period (at least six years) at the experimental site implied that the level of nematodes in the sandy soil, which infect plant roots and reduce nutrient uptake efficiency, was negligible (Nyamangara et al. 2003).

Net maize N uptake

To determine net N recovery by maize from manure and mineral fertilizer treatments, the amount of N uptake in the control treatment (no manure, no fertilizer) was subtracted from the treatments. It was assumed that there was equal uptake of soil N with or without N fertilizer or manure, i.e. no priming effect (Jokela 1992). Generally, net N uptake increased with N fertilizer rate, and efficiency of N uptake decreased from the first to the third season (Table 2). In the first season, net N uptake in the 60 kg ha⁻¹ N fertilizer treatment at 20 WAP was more than 100%, implying that the added mineral N had a priming effect on soil organic matter mineralisation (Table 2). Net N uptake from manure treatments, which was relatively lower compared to mineral fertilizer, was similar during the first season, but was significantly depressed in the 37.5 t ha⁻¹ treatment in the second season (up to 12 WAP). In the third season, net uptake was similar between the two manure treatments except at harvesting (20 WAP) when net uptake in the 37.5 t ha⁻¹ treatment was 88% higher.

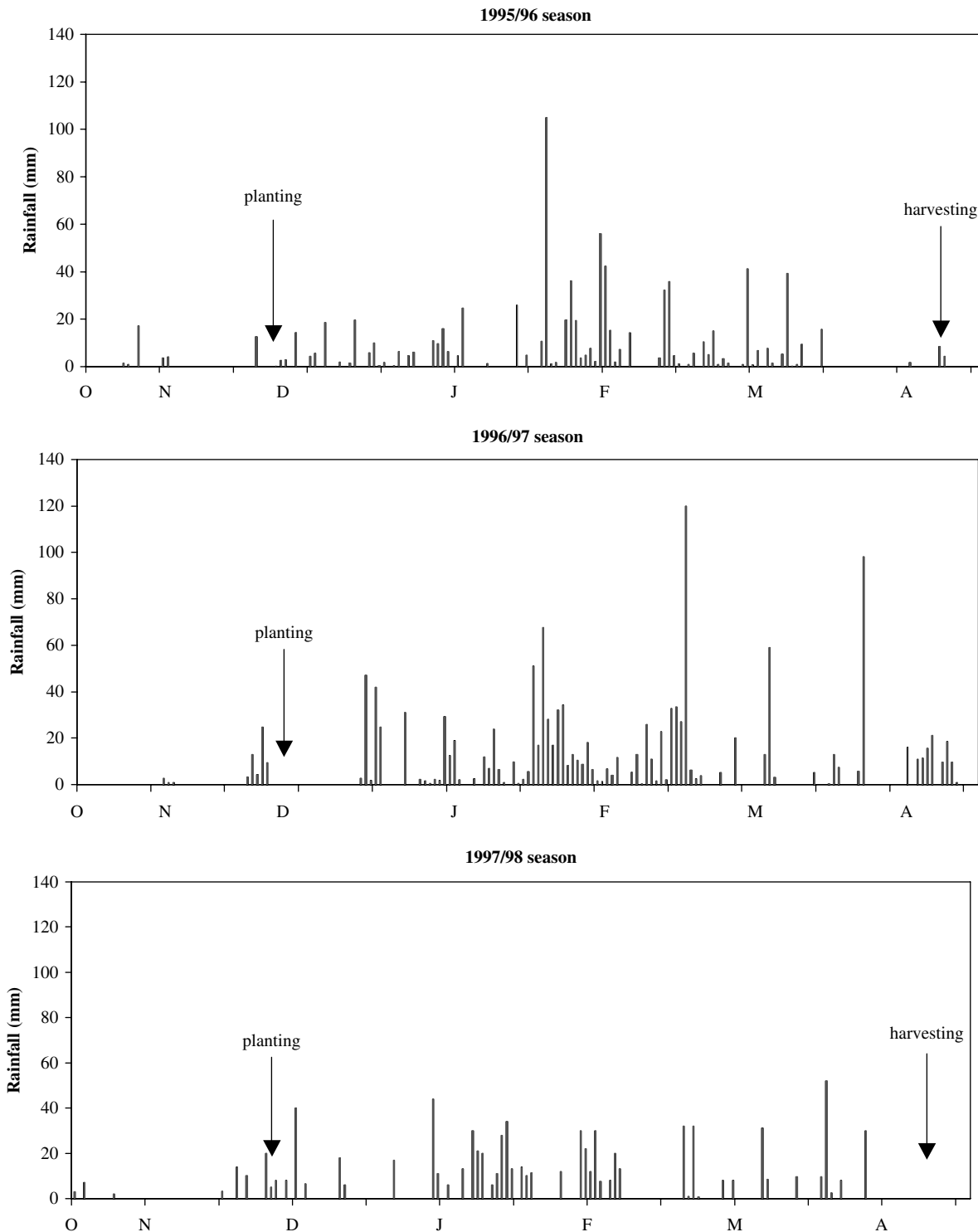

Figure 1. Daily rainfall distribution for the three experimental seasons at Domboshawa Training Centre.

Combined application of manure and mineral fertilizer significantly ($P < 0.05$) increased net N uptake for all planting seasons when compared to manure and the 60 kg ha⁻¹ fertilizer treatments. As expected, combinations of manure and the 120 kg ha⁻¹ mineral N rate resulted in higher net N uptake compared to the combination with the 60 kg ha⁻¹ mineral N rate at the end of each season (i.e. 20 WAP, and 12 WAP for 1996/97) (Table 2).

Distribution of available N in the soil profile

Generally, the highest concentrations of available N were observed in the highest N fertilizer (120 kg ha⁻¹) treatment, followed by its combination with manure (Figure 2–4). The highest available N concentrations were observed during first season (1995/96), and most of the available N was limited to the top soil (0–300 mm) at the start of the season (4 WAP). There was

Table 2. Effect of cattle manure and mineral N fertilizer on maize N uptake during three cropping seasons at Domboshawa Training Centre, Zimbabwe

Treatment	4 WAP	6 WAP	12 WAP	20 WAP
1995/96 season				
Fertilizer (kg N ha ⁻¹)			kg N ha ⁻¹	
60	0.83b	4.50cd	34.51de	60.20c
120	1.68	5.88bc	56.16c	83.10b
Manure (t ha ⁻¹)				
12.5	0.54c	5.03bcd	32.15de	46.43c
37.5	0.81b	2.81d	28.33e	50.46c
Manure + fertilizer (t ha ⁻¹) (kg N ha ⁻¹)				
12.5 + 60	1.59a	5.35bcd	38.29d	76.01b
12.5 + 120	1.62a	6.29abc	41.52d	79.66b
37.5 + 60	1.72a	7.68ab	72.57b	85.92b
37.5 + 120	1.67a	9.21a	110.80a	112.50a
1996/97 season				
Fertilizer (kg N ha ⁻¹)			kg N ha ⁻¹	
60	0.91c	14.99e	37.26d	
120	0.94de	32.01c	53.69c	
Manure (t ha ⁻¹)				
12.5	1.23b	11.35f	20.46e	
37.5	0.24e	1.73g	1.27f	
Manure + fertilizer (t ha ⁻¹) (kg N ha ⁻¹)				
12.5 + 60	0.91c	32.03c	72.96b	
12.5 + 120	0.58d	69.74b	110.90a	
37.5 + 60	0.96c	25.03d	39.36d	
37.5 + 120	1.56a	74.38a	105.90a	
1997/98 season				
Fertilizer (kg N ha ⁻¹)			kg N ha ⁻¹	
60	2.48c	4.84e	23.62bc	24.47e
120	2.61e	14.98b	42.39ab	52.80d
Manure (t ha ⁻¹)				
12.5	0.99f	2.23f	15.89c	34.40e
37.5	0.93f	4.36ef	15.11c	64.60c
Manure + fertilizer (t ha ⁻¹) (kg N ha ⁻¹)				
12.5 + 60	3.14d	8.79d	39.46ab	66.10c
12.5 + 120	4.92b	11.07	49.48	82.25b
37.5 + 60	4.31c	6.52e	49.11a	86.80b
37.5 + 120	5.52a	20.32a	55.31a	106.80a

Figures with the same digit are not significantly at 95% significance level, WAP – weeks after planting. No uptake data for 20 WAP in 1996/97 season due to cattle disturbance at the trial site.

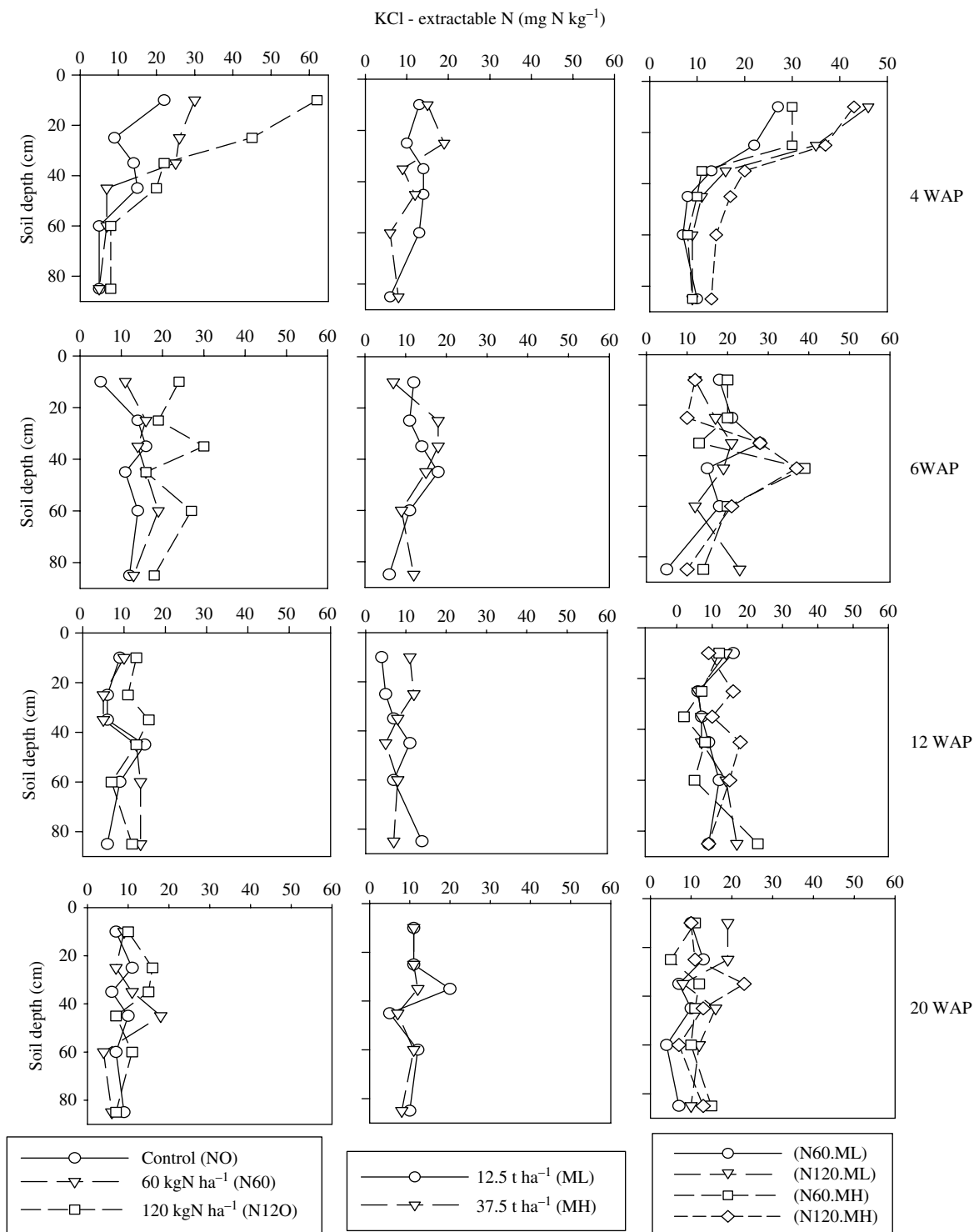

Figure 2. Effect of cattle manure and mineral N fertilizer on the distribution of mineral N in the soil profile of a maize field during the 1995/96 season at Domboshawa, Zimbabwe.

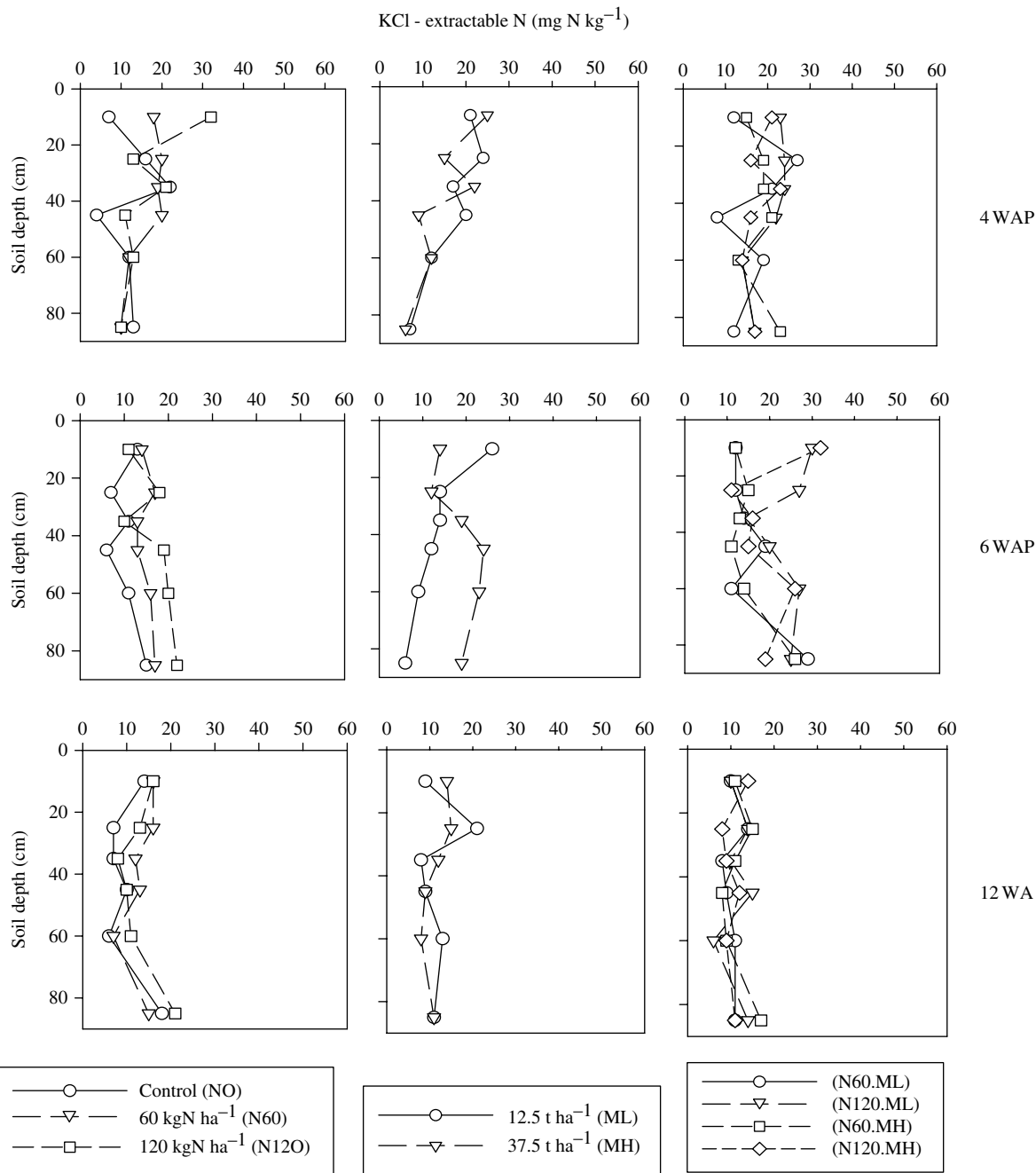

Figure 3. Effect of cattle manure and mineral N fertilizer on the distribution of mineral N in the soil profile of a maize field in 1996/97 at Domboshawa, Zimbabwe.

evidence of available N accumulation in the upper subsoil (300–500 mm) in all treatments with more pronounced accumulation in the high fertilizer rate (with or without manure) at 6 WAP, although the average concentrations were lower compared to 4 WAP.

There was no significant difference in the available N in the manure and control treatments and mineral N concentrations were low ($<20 \text{ mg kg}^{-1}$). During the second and third seasons (Figures 3 and 4), mineral N concentrations were much lower compared

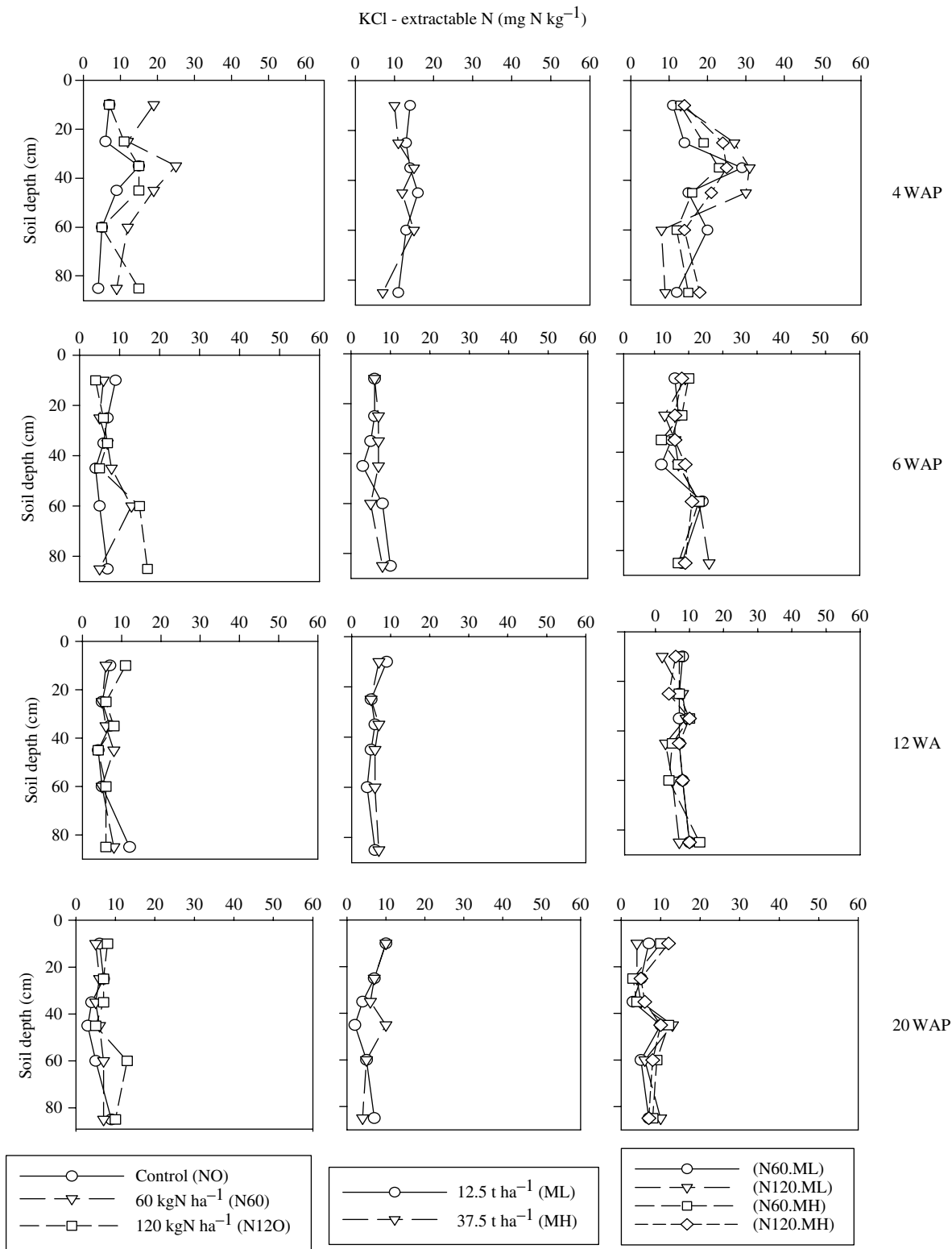

Figure 4. Effect of cattle manure and mineral N fertilizer on the distribution of mineral N in the soil profile of a maize field in 1997/98 at Domboshawa, Zimbabwe.

to the first season and there were few treatment differences.

During the first season most of the available N (up to 30 mg kg⁻¹) was concentrated in the top soil (0–300 mm) at 4 WAP, with evidence of movement into the subsoil (300–500 mm) at 6 WAP (Figure 5). Thereafter, there was limited N movement or accumulation in the soil profile at 12 and 20 WAP and mineral concentration was low (<10 mg kg⁻¹) in the whole profile. In the second season mineral N concentrations remained the same, except at 6 WAP where there was depletion in the upper subsoil. In the third season there was significant accumulation of the KCl-extractable N in the upper subsoil at 4 WAP (Figure 5).

Discussion

The much higher accumulation of mineral N in the top profile of the treatments at the start of the first season (Figure 2) was attributed to significant N mineralization from soil organic matter since the experimental site was under a grass fallow for more than six years prior to the experiment. Some mineral N was also derived from physically protected organic matter which was exposed during ploughing (Groffmann and Tiedje 1988) and from dead microbial biomass due to drying and wetting of the soil (Wong and Nortcliff 1995). The observed decline in mineral N as the season progressed was attributed to increasing crop demand. A similar pattern was also reported in Malawi (Kumwenda et al. 1998).

The higher mineral N concentration in the high N fertilizer treatment (120 kg ha⁻¹) compared with its combination with manure treatments implied that there was either a partial immobilisation of some fertilizer N or there was enhanced N uptake in manure plus fertilizer treatment. Although there was enhanced N uptake (Table 2), the reduction in soil mineral N occurred early in the season when crop demand was low implying potential N immobilization occurred. Partial immobilisation of fertilizer N was also observed in an incubation experiment using the same manure (Nyamangara et al. 1999), and could therefore explain the observed decline in mineral N in the manure plus fertilizer treatment early in the season (4 WAP). Besides, the extent of the partial N immobilization is not adequate to control excess mineral N in the soil when high N fertilizer rates are combined with the composted manure, when especially at the start of the season when crop demand for N is still low.

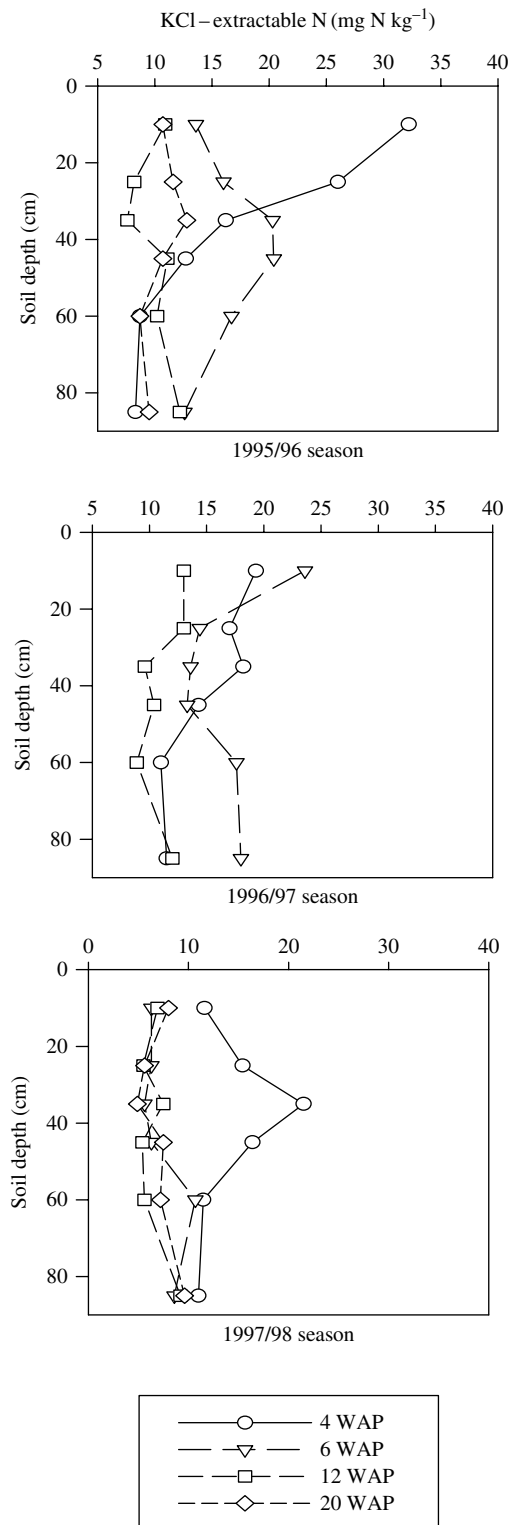

Figure 5. Overall effects of soil depth on the distribution of mineral N in the soil profile of a maize field amended with cattle manure and mineral N at Domboshawa Figure, Zimbabwe.

Depressed N uptake and limited mineral N accumulation in the manure treatments implied that either N mineralisation was low or the mineralized N was lost through gaseous and other losses. Short-term N mineralisation of the experimental manure measured in a laboratory incubation study was very low (Nyamangara et al. 1999), but enhanced N release is expected in the second or third season (Murwira and Kirchmann 1993; Jokela 1992). The results implied that there is need to supplement aerobically composted manure with some mineral N fertilizer in order to offset the negative effects of temporary N deficiency on plant growth. There is also need to assess denitrification losses from soils amended with manure since manure also provides a labile C (energy) source required by denitrifying micro-organisms.

The appearance of high mineral N levels in the top soil at four weeks after N fertilizer application, and the movement of mineral N into the upper subsoil at six weeks after planting during the first season, implied that the applied N at planting was excessive. Therefore, N uptake efficiency could usefully be increased by applying less fertilizer N at planting (a third was applied in this study) then split-applying the remainder as crop demand increases. This, though labour intensive, would also reduce the chances of excessive N leaching in case of high intensity storms. Piha (1993) successfully increased maize N uptake and yield by splitting N fertilizer application in response to rainfall distribution.

Given the high intensity storms recorded during the study period, especially during the 1996/97 season (Figure 1), and the coarse nature of the soil, it is possible that the dynamics of N movement in the soil was not captured by the sampling program. For example, Vogel et al. (1994) reported that almost all of the applied N fertilizer N was leached out of the plough layer when high intensity storms (> 100 mm in one week) followed fertilizer application. During the 1996/97 season more than 100 mm of rainfall was recorded in 24 hours. This could partly explain the low mineral N concentrations recorded in all treatments during the second and third seasons. Thus a more intensive sampling programme which will be in synchrony with rainfall events in order to capture the temporal changes in soil mineral N during the cropping season.

Conclusions

The partial immobilization of fertilizer N by aerobically manure, when the two N sources are applied in

combination, is too limited to be of practical importance in reducing N leaching early in the season when high mineral N rates are applied. The application of manure in combination with low N fertilizer is beneficial to the crop especially during the first season when N release from manure is insufficient to support optimum plant growth. Increased N uptake efficiency by maize can be enhanced by applying much less N fertilizer at planting when N demand is low, with the balance being applied in split applications during the season as crop demand increases. This would reduce N accumulation in the top soil at the start of the rainy season thereby reducing N leaching and gaseous losses. Given the low maize N uptake and low soil mineral N in the year of manure application, there is need to assess the denitrification losses during cropping season given that the availability of labile C from manure may induce rapid microbial growth followed by development of anaerobic conditions in the soil.

Acknowledgements

This study was funded by the Swedish Agency for International Development (SIDA-SAREC) through a grant (SAREC-1995-0743) coordinated by the Institute of Environmental Studies (IES) of the University of Zimbabwe, for which the author is grateful.

References

- Bremner J.M. and Mulvaney C.S. 1982. Nitrogen-total. In: A.L. Page (Ed.) *Methods of soil analysis*. American Society of Agronomy, W.L., pp. 595–622.
- Department of Meteorological Services. 1981. *Climate handbook of Zimbabwe*. Harare, 222 pp.
- Department of Meteorological Services. 1977. *Mean rainfall in Rhodesia. Rainfall Handbook Supplement No. 8*, Harare 62 pp.
- Grant P.M. 1981. The fertilisation of sandy soils in peasant agriculture. *Zim. Agric. J.* 78: 169–175.
- Grant P.M. 1976. Peasant farming on infertile soils. *Rhodesia. Science News* 10: 252–254.
- Groffmann P.M. and Tiedje J.M. 1988. Denitrification hysteresis during wetting and drying cycles in soil. *Soil Sci. Soc. Am. J.* 52: 1626–1629.
- Jokela W.E. 1992. Nitrogen fertiliser and dairy manure effects on corn yield and soil nitrate. *Soil Sci. Soc. Am. J.* 56: 148–154.
- Jury, W.A. and Nielsen, D.R. 1988. Nitrate transport and leaching mechanisms. In: R.F. Follet (Ed.) *Nitrogen management and groundwater protection*, Elsevier Science Publishers B.V., Amsterdam, pp. 139–157.
- Kamukondiwa W. and Bergström L. 1994. Nitrate leaching in field lysimeters at an agricultural site in Zimbabwe. *Soil Use & Mgmt.* 10: 118–124.

- Keeney D.R. and Nelson D.W. 1982. Nitrogen-inorganic forms. In: A.L. Page (Ed.) *Methods of soil analysis*. American Society of Agronomy, W.I., pp. 643–698.
- Khombe C.T., Dube I.A. and Nyathi P. 1992. The effects of kraaling and stover supplementation during the dry season on body weights and manure production of Mashona steers in Zimbabwe. *African Livestock Res.* 1: 18–23.
- Kumwenda J.D.T., Saka A.R., Sieglinde S.S., Ganunga R.P. and Benson T. 1998. Effects of organic legume residues and inorganic nitrogen on maize yield in Malawi. In: Waddington S.R., Murwira H.K., Kumwenda J.D.T., Hikwa D. and Tagwira F. (Eds) *Soil fertility research for maize-based farming systems in Malawi and Zimbabwe*. CIMMYT/SOIL FERT NET, Harare, pp. 165–171.
- Mugwira L.M., Mukurumbira L.M., Butai P.C. and Mandiringana O.T. 1992. Soils of the small-scale farming areas of Zimbabwe and their management. In: Whingwiri E.E., Mashingaidze K. and Rukuni M. (Eds) *Small-scale agriculture in Zimbabwe-field crop production*. Rockwood Publishers, Harare, pp. 7–21.
- Mugwira L.M. and Mukurumbira L.M. 1984. Comparative effectiveness of manures from the communal areas and commercial feedlots as plant nutrient sources. *Zim. Agric. J.* 81: 241–250.
- Murwira H.K. and Kirchmann H. 1993. Nitrogen dynamics and maize growth in a Zimbabwean sandy soil under manure fertilisation. *Commun. Soil Sci. Plant Anal.* 24: 2343–2359.
- Nhamo N. 2003. Evaluation of the efficiency of organic and inorganic fertilizer combinations in supplying nitrogen to crops. Master of Philosophy, University of Zimbabwe, Harare, pp. 109.
- Nyamapfene K.W. 1991. *Soils of Zimbabwe*. Nehanda Publishers (Pvt) Ltd, Harare, pp. 75–79.
- Nyamangara J., Piha M. and Giller K.E. 2003. Effects of combined cattle manure and mineral N fertiliser application on maize N uptake and grain yield. *African Crop Sci J.* 11: 289–300.
- Nyamangara J., Piha M.I. and Kirchmann H. 1999. Interactions of aerobically decomposed cattle manure and nitrogen fertiliser applied to soil. *Nutrient Cycling in Agroecosystems* 54: 183–188.
- Nzuma J.K., Murwira H.K. and Mpeperekwi S. 1998. Cattle manure management options for reducing nutrient losses: Farmer perceptions and solutions in Mangwende, Zimbabwe. In: Waddington S.R., Murwira H.K., Kumwenda J.D.T., Hikwa D. and Tagwira F. (Eds) *Soil fertility research for maize-based farming systems in Malawi and Zimbabwe*. CIMMYT/SOIL FERT NET, Harare, pp. 183–190.
- Piha M. 1993. Optimising fertiliser use and practical rainfall capture in a semi-arid environment with variable rainfall. *Expl Agric.* 29: 405–415.
- Roth G.W. and Fox R.H. 1990. Soil nitrate accumulations following nitrogen-fertilised corn in Pennsylvania. *J. Environ. Qual.* 19: 243–248.
- Sanchez P.A., Shepherd K.D., Soule M.J., Place F.M., Buresh R.J., Izac A.N., Mkwunye A.U., Kwasiga F.R., Ndiritu C.G. and Wooster P.L. 1997. *Soil fertility replenishment in Africa: An investment in natural resource capital*. SSSA Special Publication No. 51. Madison, W.I, pp. 1–46.
- Saunders D.H., Ellis B.S. and Hall A. 1957. Estimation of available nitrogen for advisory purposes in Southern Rhodesia. *J. Soil Sci.* 8: 301–312.
- Twomlow S.J. 1994. Field moisture characteristics for two fersiallitic soils in Zimbabwe. *Soil Use and Management* 10: 168–173.
- Vogel H., Nyagumbo I. and Olsen K. 1994. Effect of tied ridging and mulch ripping on water conservation in maize production on sandveld soils. *Der Tropenlandwirt* 95: 33–44.
- Vogel H. 1992. Morphological and hydrological characteristics of gleyic granitic soils and their potential for crop production. A case study from Zimbabwe. *Soil Technology* 5: 303–317.
- Wong M.T.F. and Nortcliff S. 1995. Seasonal fluctuations of native available N and management implications. *Fertiliser Research* 42: 13–26.

Intensity cultivation induced effects on soil organic carbon dynamic in the western cotton area of Burkina Faso

Badiori Ouattara · Korodjouma Ouattara ·
Georges Serpantié · Abdoulay Mando ·
Michel P. Sédogo · André Bationo

Abstract The soil organic carbon (SOC) dynamic is a key element of soil fertility in savannah ecosystems that form the key agricultural lands in sub-Saharan Africa. In the western part of Burkina Faso, the land use is mostly linked to cotton-based cropping systems. Use of mechanization, pesticides, and herbicides has induced modifications of the traditional shifting cultivation

and increased the need for sustainable soil fertility management. The SOC dynamic was assessed based on a large typology of land cultivation intensity at Bondoukui. Thus, 102 farm plots were sampled at a soil depth of 0–15 cm, considering field–fallow successions, the cultivation phase duration, tillage intensity, and soil texture. Physical fractionation of SOC was carried out by separating the following particle size classes: 2,000–200, 200–50, 50–20, and 0–20 μm . The results exhibited an increase in SOC stock, and a lower depletion rate with increase in clay content. After a long-term fallow period, the land cultivation led to an annual loss of 31.5 g m^{-2} (2%) of its organic carbon during the first 20 years. The different fractions of SOC content were affected by this depletion depending on cultivation intensity. The coarse SOC fraction (2,000–200 μm) was the most depleted. The ploughing-in of organic matter (manure, crop residues) and the low frequency of the tillage system produced low soil carbon loss compared with annual ploughing. Human-induced disturbances (wildfire, overgrazing, fuel wood collection, decreasing fallow duration, increasing crop duration) in savannah land did not permit the SOC levels to reach those of the shifting cultivation system.

B. Ouattara (✉) · K. Ouattara · M. P. Sédogo
Institut de l'Environnement et de Recherches
Agricoles (INERA), 04 BP 8645, Ouagadougou 04,
Burkina Faso
e-mail: badiori.ouattara@coraf.org

K. Ouattara
e-mail: korodjouma_ouattara@hotmail.com

M. P. Sédogo
e-mail: m.sedogo@fasoner.bf

G. Serpantié
Institut de Recherches pour le Développement
(IRD), BP 434 101, Antananarivo, Madagascar
e-mail: serpantie@ird.mg

A. Mando
International Center for Soil Fertility and
Agricultural Développement—Division Afrique
(IFDC), BP 4483, Lomé, Togo
e-mail: amando@ifdc.org

A. Bationo
The Tropical Soil Biology and Fertility Institute of
CIAT (TSBF-CIAT), 30677, Nairobi, Kenya
e-mail: A.bationo@cgiar.org

Keywords Cultivation intensity · Fallow ·
Savannah · Soil fractions · Soil organic carbon

This article has been previously published in the journal "Nutrient Cycling in Agroecosystems" Volume 76 Issues 2–3.

Introduction

Soil organic matter (SOM) content is considered to be a key element determining the fertility of tropical savannah soils (Piéri 1989; Sédogo 1993; Feller 1995; Six et al. 2002). Many studies have shown that organic matter dynamics in tropical areas involve several parameters determining SOM stock level. It includes the soil tillage system during the cropping period, the rainfall pattern, organic and mineral fertilizer inputs, and soil texture (Feller 1995; Chan et al. 2002; Lal 2000; Olaoye 2002).

Long-term agricultural experiments carried out both in Europe and the USA indicate that SOM is lost during intensive cultivation, typically showing an exponential decline after the first cultivation of virgin soils, but with continuing steady loss over many years (Arrouays and Péliissier 1994; Reicosky et al. 1995, 1997; Pretty and Ball 2001). The ability of soils to retain carbon and nutrients is related to soil texture and many biogeochemical processes in the ecosystem (Whendee et al. 2000). Generally, SOM increases linearly with clay content on regional and global scales (Feller et al. 1991; Parton et al. 1993; Schimel et al. 1994). However, the interactions between soil texture and biogeochemical cycling are complex. Clay soils can facilitate the formation of passive carbon pools with slow turnover times due to the physicochemical protection of SOM by clay minerals (Christensen 1992; Balesdent et al. 2000). Sandy soils are often associated with high fine root biomass in tropical forests due to greater carbon allocation to roots for nutrient and water uptake (Cuevas and Medina 1988). Evaluating the size of carbon pools and the carbon sequestration potential is presently one of the most serious and complex areas of research in environmental science (Trofimow et al. 1997). Thus, several studies dealt with the effects of tillage and cropping systems on soil organic carbon (SOC) pools and carbon sequestration (Benny et al. 2002; West and Post 2002; Gonzalez and Laird 2003; Fabrizzi et al. 2003; Mikha and Rice 2004). The chemical structure of SOM may not adequately characterize carbon turnover (Duxbury et al. 1989); thus, physical fractionation techniques, which are less destructive than chemical extractions, are commonly used. Particle size fractionation is based on

the observation that carbon in the sand fraction is generally more labile than carbon in clay and silt size fractions (Tiessen and Stewart 1983). SOM monitoring in tropical agricultural areas led to sparse results and few results exist on SOM dynamics in line with cropping systems at the farm/field level. The present study deals with land use intensity-induced effects on SOC dynamics, and size distribution in the western cotton area of Burkina Faso. It covers two contrasting landscapes, different fallow lengths, and various tillage systems. We propose to analyze, using a synchronic approach, where the SOM dynamic in different particle size fractions is related to the land use intensity.

Material and methods

The study was carried out at Bondoukui (11°51' N lat., 3°46' W long., 360 m altitude), located in the western cotton zone in Burkina Faso. Mean average annual rainfall is between 900 and 1,000 mm, and is monomodally distributed over May to October. The maximal temperatures vary between 31 and 39°C. The average potential evapotranspiration reaches 1,900 mm per year. The main vegetation types in the Bondoukui area according to Devineau et al. (1997) are related to the hydrographic network (gallery forests, grassland often subjected to flooding and the savannah system). Vegetation type prior to cropping was an open woody savannah and the main species *Vittelaria paradoxa* and *Parkia biglobosa* constitute parklands in the cultivated areas. The soil type is ferric lixisols on the highland position (plateau) and ferric luvisols on the lowland position (low glacia). The soil characteristics in the study area are shown in Table 1. The soils of the lowland area appear to be chemically richer than those of the plateau.

Preliminary studies carried out by Ouattara et al. (1999) were used to establish the typology of the fields according to the intensity of cultivation (IC) as defined by Ruthenberg (1971). Thus, three major cropping systems (MCS) were identified:

- The shifting cultivation system, characterized by short cultivation periods (<10 years) and long fallow periods (>30 years). These old fallow lands are locally called “diuré”

Table 1 Physical and chemical characteristics of Bondoukui soils (depth 0–15 cm)

Characteristics	Ferric lixisols (plateau)	Ferric luvisols (lowland)
Clay + fine silt (%)	13±8	29±10
Total sands (%)	74±11	50±13
Bulk density	1.53±0.06	1.44±0.09
Total base cations (cmol kg ⁻¹)	3.1±0.8	4.2±1.3
CEC (cmol kg ⁻¹)	3.3±1.0	4.9±1.7
Organic carbon (g kg ⁻¹)	3.9±1.4	6.3±2.0
Nitrogen (g kg ⁻¹)	0.27±0.10	0.5±0.10
pH water	5.9±0.3	6.1±0.4

CEC cation exchange capacity

- The fallow cultivation system or cyclical cultivation system with about the same duration of cultivation and fallow phases (< 10 years)
- The continuous cultivation system, interrupted by very short fallow periods (1–3 years).

These MCS were split into the length of cultivation–fallow phases, and soil tillage types (Table 2).

Ploughing was done in most cases with cattle-drawn equipment. Some farmers had tractors, but in all cases, tillage did not exceed a depth of 15 cm.

Farm plots were sampled in each soil type (the sandy plateau and the silt to silt-clay lowland). The gravel content was <5% of the sampled soils. A total of 102 farms, including 33 natural fallow lands were sampled during the dry season at a depth of 15 cm corresponding to the soil layer that was much more influenced by tillage and organic matter input. Soil was sampled in consecutive bulk density measurements using a rubber balloon densitometer in three replications. These replicates were gathered to constitute composite samples for laboratory analysis.

Finely sieved soil (sieve opening 2 mm) was used to determine soil particle size distribution using the Robinson pipette method (Mathieu and Pieltain 1998). SOM fractionation was done following a procedure based on particle-size distribution with soil dispersion (Vanlauwe 1996; Fabrizzi et al. 2003). One-hundred grams of fine air-dried soil were dispersed in 100 ml of a sodium hexametaphosphate-bicarbonate solution (20 vol concentration) mixed with 500 ml of distilled water. After dispersion, the soil slurry was wet-sieved on a wet-sieve shaker to separate the 2,000–200, 200–50, 50–20 and 0–20 µm organo-mineral fractions. The different organo-mineral particle size fractions obtained were oven-dried at 60°C and weighed.

The SOC content was measured using the Walkley and Black method adapted to Burkina soils by Gnankambary et al. (1999). The organic carbon recovery rate was between 95 and 100%. Soil effective cation exchangeable capacity (CEC) and exchangeable base cations were determined using cobaltihexamine chloride according to the method described by USDA (1996). Soil pH was measured at a soil–solution ratio of 1:2.5. Statistical analyses, ANOVA, were carried out using the software Genstat, version 6.

Results

Texture effect on soil carbon stock

Soil organic carbon stock was different for the MCS in the two types of soils in the Bondoukui agricultural landscape. The amount of carbon in the 0–15 cm layer was higher on the silty-clay texture ferric luvisols than in the sandy ferric lixisols (Fig. 1).

Table 2 Number of plots in the cropping system typology according to major cropping systems (MCS) and the tillage types

	Shifting system		System with fallow periods			Continuous system			
	F30	C10	F20	F10	C10	Plough./2 years	Plough./year	Manure	Total
Plateau	2	2	10	7	14	7	12	5	59
Low glacis	9	7	3	2	9	9	3	1	43
Total <i>n</i>	11	9	13	9	23	16	15	6	102

F30 30–40 years fallow; F10 1–10 years fallow; F20 11–20 years fallow; C10 1–10 years cultivation; Plough./2 years biennial ploughing; Plough./year annual ploughing; Manure manure ploughing-in

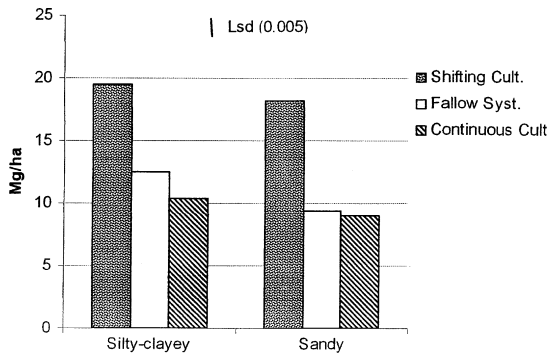

Fig. 1 Soil carbon stock in the major cropping systems (MCS) on the two types of soil

Soil clay content was the main parameter of texture that affected SOC stock. A comparative regression of SOC stock in fields and fallows according to soil clay content showed a linear regression in fallows ($y = 0.18, x + 3.3, r^2 = 0.39$), while it was better with a logarithmic adjustment in cultivated fields ($y = 2.6, \log x - 1.1, r^2 = 0.42$; Fig. 2).

Previous studies in the Bondoukui area conducted by Ouattara et al. (1999) showed two equilibrium levels of SOC contents according to the ecological conditions of the forest and the savannah. A comparative analysis of SOC stocks with these equilibrium values showed that almost all soils of the continuous cultivation system (C) are below the “savannah” line (Fig. 3). The annual ploughed plots occupied the lower limits. For soils with clay content below 10% (sandy soils), young fields of cyclical cultivation systems, cleared forest, and some organic fertilized fields displayed SOC stocks larger than savannah SOC, proving an increase in SOC stock after cultivation.

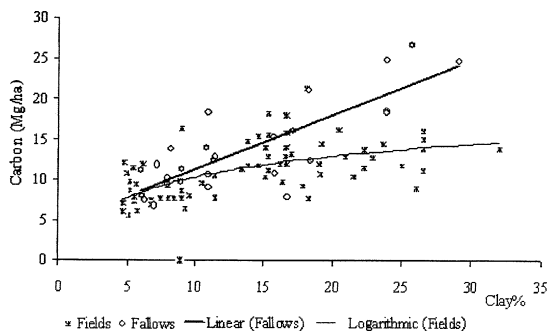

Fig. 2 Field and fallow soils carbon stocks related to soil clay content in the whole cropping systems

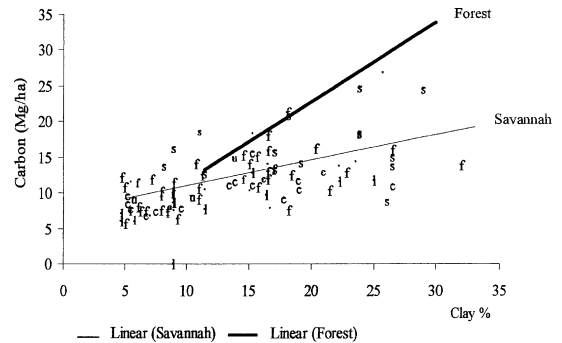

Fig. 3 The MCS soil carbon stocks related to soil clay content. *f* fallow system, *c* continuous cropping, *s* shifting cultivation

Soil carbon stock and carbon to nitrogen ratio in the different systems

The statistical analyses of SOC stocks in the two soil types showed significant differences between the shifting cultivation system and the two other MCS that were not statistically different. The average carbon stock in the shifting cultivation system was 16.90 Mg ha^{-1} , while it was 10.68 and 10.05 Mg ha^{-1} for the fallow cultivation system and the continuous cultivation system respectively (LSD = 2.43). In the shifting cultivation system the old fallows had the higher carbon stock compared with the fields on the two landscapes (Fig. 4). In the fallow system on the sandy plateau, the lower carbon stock was found in the cropped farms (Fig. 4a), while on the clay lowland the lower carbon stock was found on the short fallows, F10 (Fig. 4b). In the continuous cultivation system for the two soil types annual ploughing had the lower SOC stock compared with biennial ploughing and manure application, which were not statistically different (Fig. 4). There was a progressive decline in SOC stocks from the shifting system plots to the cyclical system then to the continuous cultivation system.

Cultivated field SOC stocks were lower than those of the natural fallows. Indeed, in natural fallows, SOC stocks increased with fallow age: 10.33 , 12.64 and 19.66 Mg ha^{-1} respectively for F10, F20, and F30, but no significant difference was found between young fallows (F10) and intermediate age fallows (F20).

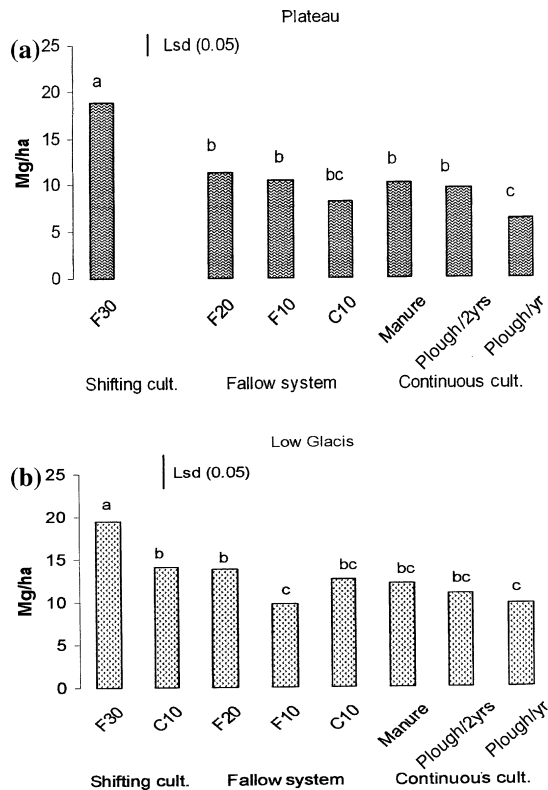

Fig. 4 Soil total carbon stock in a layer 0–15 cm in the different cultivation systems **a** on the plateau and **b** on the low glacis

The cyclical cultivation system did not induce any significant differences in SOC stocks between cropping and fallow phases. The land use change of a 20-year-old fallow led to a decrease in SOC stock, but at a lower rate than that of the shifting cultivation system.

In the continuous cropping system, SOC remained at a steady level under the cumulative effects of rotation, manure supply, and/or cattle penning. Annual ploughing led, however, to a drastic decline in SOC.

The carbon to nitrogen ratio was higher in the ferric lixisol (plateau) than in the ferric luvisol (low glacis) soils (Table 3). In both cases, the carbon to nitrogen ratio was higher in fallow soil than in cropped soils. Soil tillage led to a decrease in the carbon to nitrogen ratio and ploughing-in manure contributed to alleviating this depletion.

Carbon contents in soil particle size fractions

The amounts of carbon in the sand fractions (2,000–200 and 200–50 μm) were about the same in the two soil types, while the carbon contents in the 50–20 and 0–20 μm fractions were different for the two landscapes (Table 4).

The distribution of the SOC in soil fractions had the same trend for the plateau and the low glacis. Thus, the averages of the two landscape SOC contents in the particle size fractions were presented in the different MCS (Fig. 5). The fine-sized particle fraction (0–20 μm) contained 70–80% of total soil carbon. The carbon contents of the MCS (shifting cultivation, fallow system, and continuous cultivation) were not statistically different for the 2,000–200 and 200–50 μm fractions, while the shifting cultivation system had the highest SOC contents for the 50–20 and 0–20 μm fractions.

In the coarse fraction (2,000–200 μm) SOM contents were the highest in the F30 fallows, which was not significantly different from F20 and the manured field in the fallow system and continuous cultivation system respectively (Fig. 5). There were no significant differences between cultivation systems for SOC contents in the 200–50 μm soil fraction. The SOC contents in 50–20 and 0–20 μm soil fractions were higher in the old fallow F30 followed by C10 in the shifting culti-

Table 3 Carbon to nitrogen ratio (C:N) and mean clay content in the different cultivation systems

	Shifting system		Fallow system			Continuous system			LSD	P < F
	F30	C10	F20	F10	C10	Plough./2 year	Plough./year	Manure		
C:N plateau	19.9a		20.8a	19.0ab	10.8	20.7a	9.3c	12.7bc	6.5	<0.001
Clay plateau	23.4a		6.9b	6.2b	6.4b	6.9b	6.6b	5.9b	2.1	<0.001
C:N low glacis	17.0a	11.6b	11.8b	10.2b	12.4b	11.2b	12.3b	13.7ab	4.4	0.005
Clay low glacis	17.2ab	22.3a	13.2b	10.7b	13.2b	17.9ab	11.2b	10.2b	8.6	<0.007

Numbers followed by the same letter are not statistically different

Table 4 Soil carbon contents (g kg⁻¹ soil) in the different fractions on the two landscapes

	2,000– 200 μm	200– 50 μm	50– 20 μm	0– 20 μm	SOC
Plateau	0.40	0.40	0.51	3.01	4.35
Lowland	0.40	0.43	0.70	5.06	6.59
<i>P</i> < <i>F</i>	–	–	< 0.001	< 0.001	< 0.001
LSD	–	–	0.10	0.48	0.61

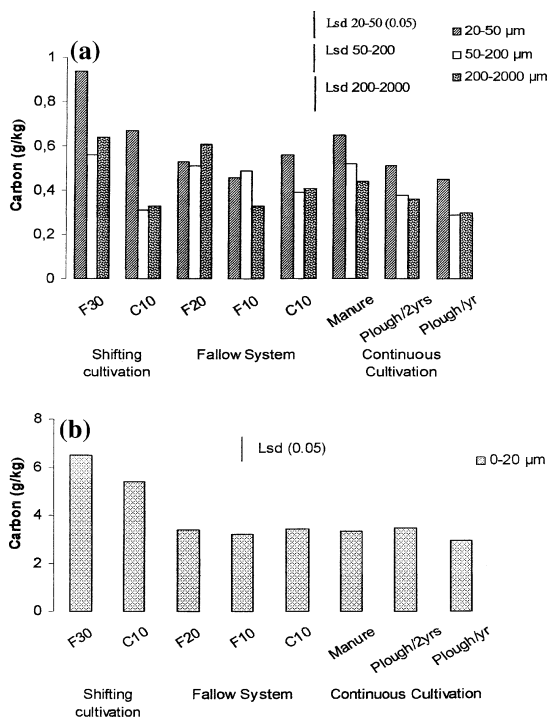
**Fig. 5** Soil carbon contents in the different particle size fractions for the cultivation systems. **a** 20–2,000 μm, **b** 0–20 μm

vation system. The lower values of SOC in these fractions were in the annual ploughing of the continuous cultivation system. There was a decreasing trend of SOC content from the shifting cultivation system to the fallow system then the continuous cultivation system (Fig. 5).

Effects of tillage intensity

The fallow lands contained more SOC than cultivated lands. Ploughing induced a decline in SOC content and the lower it is, the more the ploughing intensity (Fig. 5). Thus, annual ploughing driven by cotton–maize rotations led to

the largest losses affecting all soil particle size classes. The carbon of the fine soil fraction (0–20 μm) was affected much more. Supplying of manure, often accompanied by ploughing-in, mitigated the negative effects of intensive soil tillage. All soil particle size classes were affected by manuring, but the change was much greater in the 200–2,000 and 50–200 μm fractions.

Discussion

The importance of soil texture for SOC dynamics

The difference in SOC contents between the plateau and the low glacia may be attributed to their difference in clay content in addition to management factors. Numerous studies have shown that clay content is a relatively important determinant of SOC levels in low activity clay soils. The higher the clay content, the higher the SOM content (Feller 1993, 1995; Feller et al. 1991, 2001). In the context of Bondoukui, lowland clay soils close to the Mouhoun alluvial plain under the influence of forest ecology (more humid soils) contain twice as much carbon than the sandy soils of the plateau. Previous work carried out by Ouattara et al. (1999) has shown that the higher the fine particle content of the soil, the higher the differences between the SOC content of vegetation classes, revealing, therefore, a positive interaction between clay and vegetation (Duval et al. 1993; Albrecht et al. 1998).

Furthermore, because more clay soils lose carbon slowly during the cultivation phase, fine particles of soil not only constitute a simple “stocking compartment” for carbon (Feller et al. 2001), but they also play a protective role for SOC, as well as its coarse fraction associated with soil macro-aggregates (Chan et al. 2002) and its fine fraction (Balesdent et al. 2000; Oades 1984).

Carbon dynamic in MCS

Changes in SOC content according to land uses were assessed comparing soil organic stocks. Organic matter stocks under natural fallows were higher than those of cultivated soils. This is in

accordance with their function of soil fertility restoration (Jaiyeoba 1997; Ouattara et al. 1999). But the increase in SOM content according to the age of the fallows remained relatively low with the cyclical cultivation systems. Indeed, at 20 years old, the organic status of these fallows represented only 47% of the equilibrium level reached in the 30-year-old fallows of the shifting cultivation system. This is not in accordance with the findings of Aweto (1981) and Jaiyeoba (1988), who have shown with forest soils that an 8- to 10-years fallow period is enough to reach more than 75% of the steady level of SOM content. Such differences can be attributed to various effects induced by plot cultivation history preceding the fallow phase (practice of wildfires, overgrazing during the fallow phase, etc.)

The soil fertility restoration rate is related to the potential of vegetation reconstitution that influences the biogeochemical processes of soil. Thus, a long cultivation period, to which is added the degrading effects of mechanized soil tillage, leads to a decline in vegetative potential (stumps and roots after clearing) as well as the edaphic seminal potential corresponding to the seed bank in the soil (Mitja and Puig 1993). The Bondoukui area fallows were additionally submitted to overgrazing and wildfires, which handicapped vegetation reconstitution (César and Coulibaly 1993).

Considering the anthropogenic features of these natural savannah fallows we agree with Jaiyeoba (1997) that they can no longer play their traditional role of soil fertility restoration. Only the long-term fallows of the shifting cultivation system could play this role. However, this system is unfortunately disappearing from the Bondoukui agricultural landscape due to demographic pressure (César and Coulibaly 1993) and intensification of cultivation practices.

Soil cultivation is inexorably followed by a decrease in the SOC content (Nye and Greenland 1965; Piéri 1989; Lal 2000). The soils of the Bondoukui area did not escape this phenomenon. A decrease in the SOC content generally acts on the whole soil particle size fractions. In soils with a coarse texture, this decrease of around 45% of SOC after 20 years' cultivation represented an annual loss of 2% of SOC compared with the "savannah shifting cultivation." This corresponds

to the loss rate (root input minus mineralization) described by Piéri (1989) in his report on these same types of soils in West Africa.

Most studies on SOC kinetics for cultivated soils have shown that decline is faster during the first years following deforestation (Tiessen and Stewart 1983; Taonda 1995; Piéri 1989). The SOC of the coarse fraction, the most biologically labile, is at first most affected. After the first decade of cultivation, SOC stocks in cyclical and continuous cultivation systems seemed to reach a pseudo-equilibrium state, but this occurred more rapidly for sandy soil. The coarse fraction SOC is more sensitive to mineralization than that of the fine fraction, which is linked to clays and often protected in soil aggregates (Chan et al. 2002).

Soil tillage regime and SOC dynamics

The lowest SOC stock was observed in the continuous cultivation system under annual ploughing. This phenomenon affected the different carbon pools and especially the fine fractions of the soil. Balesdent et al. (2000) characterized this impact of ploughing according to three major actions:

- Creation of favorable pedo-climatic conditions for organic substrate biodegradation and/or SOC mineralization
- Incorporation of organic substrates into the soil matrix (soil macro-aggregates), which favors the protection of SOC against the biodegradation process or fast mineralization (Puget et al. 1996; Chan et al. 2002)
- Mechanical destruction of the soil structure under annual ploughing exposes SOC to fast mineralization. This explains its impact on organic carbon content of the fine fraction of the soil (Duval et al. 1993; Balesdent et al. 2000)

Soil macro-aggregates offer protection to SOC, and this "protection capacity" increases with SOC content, clay content, and with an absence of annual ploughing.

Organic matter supplies in the form of farmyard manure (animal waste), compost (domestic waste) generally ploughed in alleviates the negative effects of soil tillage on SOM. All soil particle size fractions were significantly affected by

ploughing, but it is more accentuated in the 200–2,000 and 50–200 μm fractions (Fig. 5). Feller et al. (1983) characterized these fractions as organic matter “entry compartments.”

Conclusion

Soil carbon fractionations showed a difference between the ferric lixisols and ferric luvisols in the Bondoukui area. This difference was expressed in the fine fractions (20–50 and 0–20 μm) and was due to the difference in clay content between the “sandy” lixisols and the “loamy” to “clay” luvisols. In general, SOC content decreased from the fallows of the shifting cultivation system toward the practice with the greater cultivation intensity value (continuous cropping system). Considering the tillage intensity, it appeared that SOC stock decreased from fallow lands to annual ploughing plots. This decrease affected all particle fractions. But if ploughing was associated with organic fertilization, the carbon loss was lower. SOC dynamics are driven by soil type and land use in relation to climate factors. These factors interact to determine the physical, chemical, and biological processes of the SOC dynamic. Understanding SOC dynamics under different agricultural and natural systems in the tropics is still a challenge for the choice of tools and practices that will contribute to an increase in soil carbon sequestration.

References

- Albrecht A, Angers DA, Beare MH, Blanchart E (1998) Déterminants organiques et biologiques de l'agrégation: implications pour la recapitalisation de la fertilité physique des sols tropicaux. *Cah Agric* 7:357–363
- Arrouays D, Pélissier P (1994) Changes in carbon storage in temperate humic soils after forest clearing and continuous corn cropping in France. *Plant Soil* 160:215–223
- Aweto AO (1981) Organic building-up in fallow soil in a part of south-western Nigeria and its effect on soil properties. *J Biogeogr* 8:67–74
- Balesdent J, Chenu C, Balabane M (2000) Relationship of soil organic matter dynamics to physical protection and tillage. *Soil Tillage Res* 53:215–230
- Benny C, Jorge T, Ashish PD, Patrick GH, Yona C (2002) Structural characterization of soil organic matter and humic acids in particle-size fractions of an agricultural soil. *Soil Sci Soc Am J* 66:129–141
- César J, Coulibaly Z (1993) Conséquences de l'accroissement démographique sur la qualité de la jachère dans le Nord de la Côte d'Ivoire. In: Floret C, Serpantié G (eds) *La jachère en Afrique de l'Ouest*. ORSTOM, Montpellier, pp 415–434
- Chan KY, Heenan DP, Oates A (2002) Soil carbon fractions and relationship to soil quality under different tillage and stubble management. *Soil Tillage Res* 63:133–139
- Christensen BT (1992) Physical fractionation of soil organic matter in primary particle size and density separates. *Adv Soil Sci* 20:1–90
- Cuevas E, Medina E (1988) Nutrient dynamics within Amazonian forest ecosystems. 2. Fine root growth, nutrient availability and leaf decomposition. *Oecologia* 76:222–235
- Devineau JL, Fournier A, Kaloga B (1997) Les sols et la végétation de Bondoukui (Ouest burkinabé). Présentation générale et cartographie préliminaire par télédétection satellitaire (SPOT). ORSTOM, Paris, p 111
- Duval M, Angers DA, Laverdière MR (1993) Revue de quelques facteurs régissant l'état et la stabilité de la structure du sol. *Agrosol VI* 2:44–51
- Duxbury JM, Scott MS, Doran JW, Jordan C, Szott L, Vance E (1989) Soil organic matter as a source and a sink of plant nutrients. In: Coleman DC, Oades JM, Uehara G (eds) *Dynamics of soil organic matter in tropical ecosystems*. University of Hawaii Press, Honolulu, pp 33–67
- Fabrizzi KF, Morón A, García FO (2003) Soil carbon and nitrogen organic fractions in degraded vs. non-degraded Mollisols in Argentina. *Soil Sci Soc Am J* 67:1831–1841
- Feller C (1993) Organic inputs, soil organic matter and functional soil organic compartments in low-activity clay soils in tropical zones. In: Mulongoy KMR (ed) *Soil organic matter dynamics and sustainability of tropical agriculture*. Wiley-Sayce, Leuven, pp 77–88
- Feller C (1995) La matière organique du sol et la recherche d'indicateurs de la durabilité des systèmes de culture dans les régions tropicales semi-arides et subhumides d'Afrique de l'Ouest. In: Ganry F, Campbell B (eds) *SCOPE workshop: sustainable land management in African semi-arid and subhumid regions*. Scope, Dakar, p 406
- Feller C, Bernhard-Reversat F, Garcia JL, Panter JJ, Roussos S, Van Vliet-lanoe B (1983) Etude de la matière organique de différentes fractions granulométriques d'un sol sableux tropical. Effet d'un amendement organique (compost). *Cah ORSTOM Sér Pédol* 20:223–238
- Feller C, Fritsch E, Poss R, Valentin C (1991) Effet de la texture sur le stockage et la dynamique des matières organiques dans quelques sols ferrugineux et ferrallitiques (Afrique de l'Ouest, en particulier). *Cah ORSTOM Sér Pédol XXVI*:25–36
- Feller C, Albrecht A, Blanchart E, Cabidoche YM, Chevalier T, Hartmann C, Eschenbrenner V, Larré-Larrouy MC, Ndandou JF (2001) Soil organic

- carbon sequestration in tropical areas. General considerations and analysis of some edaphic determinants for Lesser Antilles soils. *Nutr Cycl Agroecosyst* 61:19–31
- Gnankambary Z, Sédogo MP, Hien V, Lompo F (1999) Détermination du facteur de correction de la méthode Walkley et Black pour le dosage du carbone organique dans les sols ferrugineux tropicaux du Burkina Faso. In: SOAChim (ed) Communication aux 5^e Journées annuelles, Niamey, 2–7 août 1999, p 5
- Gonzalez JM, Laird DA (2003) Carbon sequestration in clay mineral fractions from 14C-labeled plant residues. *Soil Sci Soc Am J* 67:1715–1720
- Jaiyeoba IA (1988) Build-up of organic matter and nutrients under fallow in a tropical rain-forest environment, Nigeria. *Malays J Trop Geogr* 18:10–16
- Jaiyeoba IA (1997) An assessment of soil fertility restoration under fallow in Nigerian savannah. *Soil Use Manage* 13:163–167
- Lal R (2000) Land use and cropping system effects on restoring soil carbon pool of degraded Alfisols in Western Nigeria. In: Lal R, Kimble JM, Stewart BA (eds) *Advances in soil science*. CRC Press LLC, New York, pp 157–165
- Mathieu C, Pieltain F (1998) *Analyse physique des sols: méthodes choisies*. Lavoisier Tec & Doc, Paris, p 275
- Mikha MM, Rice CW (2004) Tillage and manure effects on soil and aggregate-associated carbon and nitrogen. *Soil Sci Soc Am J* 68:809–816
- Mitja D, Puig H (1993) Essartage, culture itinérante et reconstitution de la végétation dans les jachères en savane humide de la Côte d'Ivoire (Booro-Borotou, Touba). In: Floret C, Serpantié G (eds) *La jachère en Afrique de l'Ouest*. ORSTOM, Montpellier, pp 377–392
- Nye PH, Greenland DJ (1965) The soil under shifting cultivation. *Commonwealth Bureau of Soil*, p 151
- Oades JM (1984) Soil organic matter and structural stability: mechanisms and implications for management. *Plant Soil* 76:319–337
- Olaoye JO (2002) Influence of tillage on crop residue cover, soil properties and yield components of cowpea in derived savannah ectones of Nigeria. *Soil Tillage Res* 64:179–187
- Ouattara B, Serpantié G, Ouattara K, Hien V, Bilgo A (1999) Etats structuraux des sols de culture et des jachères en zone cotonnière du Burkina Faso. In: Floret C, Pontanier R (eds) *La jachère en Afrique tropicale. Rôles, aménagement, alternatives*. Dakar, pp 170–178
- Parton WJ, Scurlock JMO, Ojima DS, Gilmanov TG, Scholes RG, Schimel DS, Kirchmer T, Menaut JC, Seastedt T (1993) Observations and modeling of biomass and soil organic matter dynamics for the grassland biome worldwide. *Global Biogeochem Cycles* 7:785–809
- Piéri C (1989) Fertilité des terres de savane: bilan de trente ans de recherche et de développement agricole au sud du Sahara. CIRAD, Paris, p 444
- Pretty J, Ball A (2001) Agricultural influence on carbon emissions and sequestration: a review of evidence and the emerging trading options. Centre for Environment and Society Occasional paper, University of Essex, 2001–2003, p 31
- Puget P, Besnard E, Chenu C (1996) Une méthode de fractionnement des matières organiques particulaires selon leur localisation dans les agrégats. *CR Acad Sci Paris Sér II* 322:965–972
- Reicosky DC, Kemper WD, Langdale GW, Douglas CL, Rasmussen PE (1995) Soil organic matter changes resulting from tillage and biomass production. *J Soil Water Conserv* 50(3):253–261
- Reicosky DC, Dugas WA, Torbert HA (1997) Tillage-induced soil carbon dioxide loss from different cropping systems. *Soil Tillage Res* 41:105–118
- Ruthenberg H (1971) *Farming systems in the tropics*. Oxford Science Publications, Oxford, p 424
- Schimel DS, Braswell BH, Holland EA, Mckeown R, Ojima DS, Painter TH, Parton WJ, Townsend AR (1994) Climatic, edaphic, and biotic controls over storage and turnover of carbon in soils. *Global Biogeochem Cycles* 8:279–293
- Sédogo MP (1993) Evolution des sols ferrugineux lessivés sous culture: incidence des modes de gestion sur la fertilité. Université Nationale de Côte d'Ivoire, Abidjan, p 285
- Six J, Feller C, Denef K, Ogle SM, Sa DMJC (2002) Soil organic matter, biota and aggregation in temperate and tropical soils—effects of no-tillage. *Agronomie* 22:755–775
- Taonda JB (1995) Evolution de la fertilité des sols sur un front pionnier en zone nord-soudanienne (Burkina Faso). INPL/ENSAIA, Nancy, p 133
- Tiessen H, Stewart JWB (1983) Particle-size fractions and their use in studies of organic matter composition in size. *Soil Sci Soc Am J* 47:509–514
- Trofimov SY, Goncharuk NY, Dorofeeva EI (1997) Carbon reserves in the undisturbed soils of southern Taiga (by the example of the Central Forest State Biospheric Reserve). *Eurasian Soil Sci* 30:1079–1084
- USDA (1996) *Soil survey laboratory methods manual*, soil survey report no. 42, version 3, p 716
- Vanlauwe B (1996) Residue quality, decomposition and soil organic matter dynamics under sub-humid tropical conditions. In: *Faculteit Landbouwkunde en Toegepaste Bilogische Wetenschappen van de K.U. Leuven*, K.U. Leuven, p 203
- West TO, Post WM (2002) Soil organic carbon sequestration rates by tillage and crop rotation: a global data analysis. *Soil Sci Soc Am J* 66:1930–1946
- Whendee LS, Neff J, McGroddy M, Veldkamp E, Keller M, Cosme R (2000) Effects of soil texture on below-ground carbon and nutrient storage in a lowland Amazonian forest ecosystem. *Ecosystems* 3:193–209

Assessment of improved soil fertility and water harvesting technologies through community based on-farm trials in the ASALs of Kenya

Gichangi E.M., Njiru E.N., Itabari J.K., Wambua J.M., Maina J.N. and Karuku A.
*Land and Water Resources Management Programme, Kenya Agricultural Research Institute (KARI),
KARI-Katamani, P.O. Box 340-90100, Machakos, Kenya, Email: karikat@africaonline.co.ke*

Abstract

Low soil fertility and moisture deficits are major constraints to crop production in the semi-arid areas of Kenya. Farmers in these areas use farmyard manure (FYM) as a cheaper alternative source of plant nutrients as opposed to the more costly inorganic fertilizers. Community based on-farm trials were conducted in 4 hot and dry semi arid districts (Machakos, Kitui, Mwingi and Mbeere), and in 2 cool and dry semi arid parts of Laikipia and Kiambu districts. The trials were aimed at evaluating the effect of improved soil fertility and water harvesting technologies (open furrows and tied ridges) on the yield of maize and beans over a period of 4 seasons. The study also aimed at identifying opportunities for improvement and modification of the technologies from farmers' observations and feedback. A number of technological options were offered to farmers for testing and treatments were replicated on between 20 to 30 farms. The treatments were 10 t FYM ha⁻¹, 20 t FYM ha⁻¹, 20 kg N + 20 kg P₂O₅ ha⁻¹, 10 t FYM + 20 kg N ha⁻¹ and 10t FYM + 20 kg N + 20 kgP₂O₅ ha⁻¹ for maize. For the beans-based trials the treatments included 5 t FYM ha⁻¹, 10 t FYM ha⁻¹, 50 kg DAP ha⁻¹, 100 kg DAP ha⁻¹ and 5 t FYM + 50 kg DAP ha⁻¹. The fertility treatments were all tested with or without water harvesting in a randomised complete block design (RCBD). In all the clusters, use of manure or inorganic fertilizer increased the yield of maize and beans. Treatments that received 10t FYM + 20 kg N + 20 kg P₂O₅ ha⁻¹ produced the highest yields followed by treatments that received 10 t FYM + 20 kg N ha⁻¹. The trend was similar for treatments that received 100 kg DAP ha⁻¹ and those that received 5 t FYM + 50 kg DAP ha⁻¹ for the bean trials. Higher net benefits were realised when organic and inorganic fertilizers were applied as compared to the control. Treatments that received both organic and inorganic fertilizer (10 t FYM + 20 kg N ha⁻¹ + 20 kg P₂O₅ ha⁻¹) had the highest net benefits of Kenya Shillings (KShs.) 19,166 for maize while for the beans the highest net benefits (KShs. 27,535) were obtained with 5t FYM + 50 kg DAP ha⁻¹. It is therefore recommended that farmers need to augment the limited quantities of farmyard manures available on smallholder farms with inorganic fertilizers and combining with appropriate water harvesting techniques for increasing the yields of maize and beans

Key words: Arid and semi arid lands (ASALS), Farm yard manure, Soil fertility, Water harvesting technologies

Introduction

The dilemma facing agriculture in Africa and most of the other third world countries is how to achieve sufficient food production in the face of declining soil fertility and productivity coupled with rising costs of agricultural inputs (Adetunji, 1997). In the past, the

crop production systems relied on shifting cultivation to maintain the fertility and productivity of the soil through organic matter and plant nutrient build-up during the fallow period (Adetunji, 1997). But with the increasing population, the demand for food has increased and this has necessitated more intensive and continuous cultivation of the land. This has resulted

in the shortening of the fallow periods making them less effective in maintaining and restoring soil fertility (Adetunji, 1997).

Socio-economic, policy and biophysical constraints, in general, and soil related constraints and management practices, in particular, are factors identified as major causes of low crop production, soil fertility decline, and ultimately degradation of the agricultural land in the tropics and subtropics (Giller *et al.*, 1998a; Simpson *et al.*, 1996; Smaling, 1993; Woomer *et al.*, 1998, Kapkiyai *et al.*, 1998). Inadequate replenishment of removed nutrients and continued loss of organic matter from the soils are contributing to increasing erosion rates and the decline in soil fertility (Kapkiyai *et al.*, 1998). The soils have poor nutrient retention capacity, and many are heavily leached and eroded (Smaling 1993; Woomer *et al.*, 1998; Kapkiyai *et al.*, 1998). Superimposed on these inherently fragile resources and constraints is the continuous removal through cropping of plant nutrients in quantities that are significantly greater than those being returned to the soil by mineral or organic fertilizers amendments (Smaling *et al.*, 1992; Woomer *et al.*, 1998; Giller *et al.*, 1998a).

In the dry parts of Kenya, the problem of soil fertility is exacerbated by the vagaries of weather, especially rainfall. The areas are characterised by low and highly variable seasonal rainfall making crop failures a common feature. Consequently, risk-averse farmers are unwilling to invest in fertilizers and other inputs that are required for high levels of agricultural production. Water harvesting supports a flourishing agriculture in many dry areas (Oweis and Taimeh, 1996; Oweis, 1994; Perrier, 1990; Suleman *et al.*, 1995; Giller *et al.*, 1998b). Given this scenario, water harvesting and integrated nutrient management (INM) are thus seen as the most important strategies for increasing crop production in these areas, while simultaneously conserving the environment. Organic inputs are often proposed as alternative to inorganic fertilizers. However, the traditional inputs of crop residues and animal manures cannot meet the crop nutrient demands over large areas because of limited quantities of the materials and the high labour demands required for processing and application (Palm *et al.*, 1997).

The trials reported herein were a continuation of on-farm soil fertility and water harvesting trials started in October 1997. The original trials were designed and managed by researchers. After the third season, emphasis shifted from researcher managed to community-based farmer managed trials to determine their ability to improve the two factors. It was also

felt that such farmer-managed trials could bring to light factors that could hinder acceptance and adoption of the technologies under investigation. The design and choice of technologies tested were done through Participatory Learning and Action Research (PLAR) procedure (Defoer and Budelman, 2000). The trials were conducted in four semi-arid districts of Kenya (Mwingi, Kitui, Machakos and Mbeere) and in the semi-arid parts of Kiambu and Laikipia districts where past research work indicated that high returns were achieved when appropriate nutrient management and water harvesting techniques were used (Watiki *et al.*, 1999). Simple and appropriate recommendations were selected for testing. The objective of the trials was to determine the performance of selected improved soil fertility and water harvesting techniques under the farmers' own resources and management capabilities.

Materials and methods

Farmer selection

The experiments were conducted at six sites (Masii, Kiomo, Kwa Vonza, Mavuria, Ndeiya and Murungai) in agro-ecological zones 4 and 5 of Machakos, Mwingi, Kitui, Mbeere, Kiambu and Laikipia districts, respectively with a cluster of 20 to 30 farms per site. Participating farmers were selected by their colleagues in group meetings (*barazas*) and each farmer selected 2 to 3 treatments that best suited his or her resources from a package provided by the research team in consultation with the farmers. The participatory Learning and Action Research (PLAR) procedure was used throughout the trial process. Before the beginning of the trials, all farmers in the individual clusters were categorised into three soil and water management groups as high, medium and low. The criteria for categorisation were formulated by the farmers and included terracing, manure application, early/dry planting, early first and second weeding and timely crop protection.

The low category farmers were described as those who hardly applied any of those criteria listed above. Medium category farmers were those who applied some or about half of the criteria while the high category farmers were those who applied most or all the criteria listed above.

Farmers participating in the trials were selected from each of the three categories by their colleagues using the following criteria: Accessibility to the farms, socially accepted by other farmers, willingness to allow

Table 1. Farmer category based on soil and water management practices in Kiomo, Mavuria and Kwa-Vonza

Cluster	Farmers category			Number of farmers categorised
	High	Medium	Low	
Kiomo	0	36	74	110
Mavuria	11	67	49	127
Kwa Vonza	16	84	98	198
Total	27	187	221	435

other farmers to visit and learn from his/her farm, a resident/available and not a telephone farmer and willingness to participate in the trials. Table 1 below shows the participating farmers at Kiomo, Mavuria and Kwa Vonza and how they were categorised by the farmers present at the barazas.

Farmers chose one or two of the options offered to test alongside their normal practices. Farmers carried out all the activities with researchers and extensionists providing advice on the types and amounts of inorganic

fertilizer and farmyard manure to apply, when to apply, method of tying ridges and any other agronomic advice that the farmers required.

Selection of treatments

During the meetings and workshops researchers and extensionists interacted with farmers to list and prioritise their problems. Causes of low crop yields and potential solutions for increasing yields were also identified. Maize and beans were given special emphasis among other crops due to their importance as staple food crops. A basket of soil fertility and water harvesting technology choices were discussed. Use of FYM and inorganic fertilizers alone or in combination and applied at different rates were selected for the trial. Farmers chose options which they considered appropriate in their farming practices and which they could afford. The choice to tie ridges depended on the cropping pattern and the availability of oxen at planting and weeding times. Tables 2 and 3 below show the fertility

Table 2. Fertility improvement options for maize production Masii, Kwa-Vonza, Kiomo and Mavuria clusters

Treatments	Category of farmers
10 t FYM ha ⁻¹	Farmers who produce little farmyard manure on their farms and are unable to purchase inorganic fertilizers.
20 t FYM ha ⁻¹	Farmers who produce large quantities of farmyard manure on their farms and are unable to purchase inorganic fertilizers.
20 kg N ha ⁻¹ + 20 kgP ₂ O ₅ ha ⁻¹	Farmers who do not produce farmyard manure on their farms but have cash to purchase inorganic fertilizers.
10 t FYM ha ⁻¹ + 20 kg N ha ⁻¹	Farmers who produce little farmyard manure and have some little cash to purchase inorganic fertilizers after planting. Such farmers claimed they are unable to purchase inorganic fertilizers at the beginning of the season due to high demands for cash from labour and seed.
10 t FYM ha ⁻¹ + 20 kg N ha ⁻¹ + 20 kgP ₂ O ₅ ha ⁻¹	Farmers who produce little farmyard manure and have cash to purchase inorganic fertilizers at the beginning of the season.

Table 3. Fertility improvement options for beans production in Murungai and Ndeiya clusters

Treatments	Category of farmers
5 t FYM ha ⁻¹	Farmers who produce little farmyard manure on their farms and are unable to purchase inorganic fertilizers.
10 t FYM ha ⁻¹	Farmers who produce large quantities of farmyard manure on their farms and are unable to purchase inorganic fertilizers.
50 kg DAP ha ⁻¹	Farmers who have little cash to purchase inorganic fertilizers at planting.
100 kg DAP ha ⁻¹	Farmers who have cash to purchase inorganic fertilizers at the beginning of the season.
5 t FYM ha ⁻¹ + 50 kg DAP ha ⁻¹	Farmers who produce little farmyard manure and have little cash to purchase inorganic fertilizers at the beginning of the season.

improvement options for maize and bean production offered to farmers for testing. A randomised complete block design (RCBD) was used and the replication was done across farms. Statistical analysis was conducted using GENSTAT 5 Release 3.2 Means were considered different at $P \leq 0.05$. All the above treatments were tested with open furrows or tied ridging.

Manure and soil analysis

Analysis of soil nutrient status in the cluster sites was done at the beginning of the trials. Soil samples were collected from terraces on which the trials were to be conducted at a depth of 0-30 cm and analysed for total N, C and available P. Soil was collected from several cores and thoroughly mixed to get a composite sample for each farm. Manure samples were also collected from manure heaps on the farms for chemical analysis.

Monitoring and evaluation

Responsibilities of the researchers, extensionists and farmers in the implementation of the trials were discussed and agreed upon at the initial stages of the trials. All the stakeholders were jointly involved in planning, design, implementation and monitoring of the trials. The trials were monitored twice during the growing season. During such visits, individual farmer interviews were held to gather farmers' views on the performance of the trials. Farmers' field days were also used in the evaluation of the trial results. During the field days, participating and non-participating farmers toured experimental plots and viewed the crop. Farmers' workshops were held at the end of each cropping season to discuss the results of the just ended season. This was aimed at enabling farmers to play a role in the

formulation of recommendations. Experimental yield results were presented to both participating and non-participating farmers in form of bar charts. Farmer to farmer visits within and between clusters was encouraged and these provided a forum for individual farmers to be challenged to put in more effort in technology development and adoption.

Results and discussion

Soil tests indicated that the soils were deficient in both total nitrogen and phosphorus and the carbon levels were also low (Table 4).

Crop response to fertility improvement

In all the clusters, use of farmyard manure, inorganic fertilizer or a combination of the two increased the yield of maize and beans over the 4 seasons of experimentation. Treatments that received 10 t FYM ha⁻¹ plus both 20 kg N ha⁻¹ and 20 kg P₂O₅ ha⁻¹ produced higher yields than all the other treatments and were followed by treatments that received 10 t FYM ha⁻¹ amended with 20 kg N ha⁻¹. Plots with no fertility improvement interventions had the least yield (Tables 5 and 6). Water harvesting had little effect on treatments that had no fertility improvement. The benefits of water harvesting increased with increasing rates of fertilizer.

There was complementary effect of manure and inorganic fertilizer on the yield of maize and beans (Tables 5 and 6). The gross maize yield increment of 287% from these two inputs was slightly greater than the sum total of the two sources when applied separately (Table 5). Yield increment from the application of 20 kg N and 20 kg P₂O₅ (256.5% with water harvesting and 231.9%

Table 4. Chemical characteristics of the soils from Masii, Kwa-Vonza, Kiomo, Mavuria and Murungai clusters

Site	Mean soil N, P, K and at the beginning of the trials				
	%N	%K	Total P mg/kg	%C	C/N ratio
Masii	0.33	0.47	24.5	0.99	3
Kwa Vonza	0.19	0.30	35.73	0.99	5
Kiomo	0.26	0.54	33.52	1.37	5
Mavuria	0.16	0.35	13.15	1.02	6
Murungai	0.36	0.96	39.99	1.57	5
Critical values (N & P)	0.2	–	20.0	–	–

Table 5. Average maize grain yields (kg ha⁻¹) across sites and across seasons (Kiomo, Masii, Mavuria, Kwa-Vonza)

Treatments	Average grain yield (kg ha ⁻¹)		% increase+water harvesting	% increase–water harvesting
	+water harvesting	–water harvesting		
0 FYM	655.0	483.0		
10t FYM	1319.4	788.0	101.4	63.1
20t FYM	1866.9	1284.0	185.0	165.8
20 kg N	1466.9	1167.0	123.8	141.6
20 kg N, 20 kg P ₂ O ₅	2035.0	1603.0	256.5	231.9
10t FYM, 20 kg N	2536.8	1784.0	287.3	269.4
10t FYM, 20 kg N, 20 kg P ₂ O ₅	3007.0	2155.0	359.1	346.2

LSD_{0.05} (values in + and – water harvesting columns) = 407.6.

Table 6. Average bean grain yields (kg ha⁻¹) across sites and across seasons (Ndeiya, Murungai)

Treatment	Average grain yield (kg ha ⁻¹)		% increase+water harvesting	% increase–water harvesting
	+water harvesting	–water harvesting		
0 FYM	560.2	441.0		
5t FYM	723.3	467.0	29.1	5.9
10t FYM	883.1	523.0	57.6	18.6
50 kg DAP	991.7	635.0	77.0	44.0
100 kg DAP	1213.5	740.7	116.6	68.0
5t FYM, 50 kg DAP	1375.0	1007.0	145.4	128.3

LSD_{0.05} (values in + and – water harvesting columns) = 189.3.

without water harvesting) was much higher than that from the application of 20 kg N ha⁻¹ alone. This indicates that once the N requirement of the crop was met, P supplied in the compound fertilizer (20:20:0) provided an extra increase in yield. The principle of integrated nutrient management was underscored by the much higher yields obtained when manure was supplemented with N or with compound fertilizer. Studies carried out elsewhere have also indicated that the efficacy of FYM is improved by supplementation with inorganic fertilizers (Watiki *et al.*, 1999; Obaga *et al.*, 2000; Onyango *et al.*, 2000; Kute and Chirchir, 2000). Moisture stress during flowering and grain filling resulted in low yields and low crop response to fertility improvement particularly during the long rains in Masii, Kwa-Vonza, Kiomo and Mavuria. However, the response to improved soil fertility was evident in the yield of beans in both seasons (long and short rains) in Ndeiya and Murungai clusters. The mean bean yield increased with increasing levels of fertility

improvement particularly when water harvesting was incorporated (Table 6).

The major interactions were likely to be due to the effects of the addition of available C on the mineralization of N and the effect of P on the capture of mineral N in soil due to increased root growth or due to increased N₂ fixation in beans.

Economic analysis

Higher net benefits were realised when organic and inorganic fertilizers were applied as compared to the control (Tables 7 and 8). Treatments that received both organic and inorganic fertilizer (10 t FYM plus 20 kg N ha⁻¹ plus 20 kg P₂O₅ ha⁻¹) had the highest net benefits of KShs. 19,166 for maize (Table 6). The highest net benefits for beans were KShs. 27,535 when 5 t FYM plus 50 kg DAP was applied (Table 8).

Table 7. The effect of soil fertility improvement on net benefits for maize in Masii, Kwa-Vonza, Kiomo and Mavuria clusters

Treatments	Net benefits (KShs/ha)		
	+ water harvesting	- water harvesting	Difference
0 FYM	4,880	3,864	1,016
10 t FYM	8,245	4,354	3,891
20 t FYM	10,675	6,372	3,719
20 kg N	8,988	6,956	2,032
20 kg N + 20 kg P ₂ O ₅	13,340	10,244	3,096
10 t FYM + 20 kg N	15,604	9,942	5,662
10 t FYM + 20 kg N + 20 kg P ₂ O ₅	19,166	12,710	6,456

Table 8. The effect of soil fertility improvement on net benefits for beans in Ndeiya and Murungai clusters

Treatments	Net benefits (KShs./ha)		
	+ water harvesting	- water harvesting	Difference
0 FYM	11,964	9,702	2,262
5 t FYM	14,578	9,299	5,276
10 t FYM	17,118	9,556	7,562
50 kg DAP	20,077	12,590	7,487
100 kg DAP	23,757	13,715	10,042
5 t FYM + 50 kg DAP	27,535	19,799	7,736

The differences in net benefits between tied ridging and open furrows were higher when both organic and inorganic fertilizers were applied to maize at Masii, Kwa-Vonza, Kiomo and Mavuria. However, the difference was higher when 100 kg of DAP was applied in beans than when both organic and inorganic fertilizers were applied at Ndeiya and Murungai (Tables 7 and 8).

Farmers' assessment

Farmers were impressed by the yield gains from the addition of nutrients and water harvesting. During field days and inter-group visits, most farmers preferred treatments that gave higher maize and bean yields compared to their traditional treatments. They ranked combined half rates of organic and inorganic fertilizers as the best treatments. They did not attach much value to FYM collection but were mainly worried about the labour requirements for applying the manure in the furrows. They were also impressed with water harvesting through tied ridges but noted that a suitable implement or an attachment be fabricated that could allow tying of the ridges easier.

Conclusion

The results of this study have shown the need to augment the limited quantities of farmyard manure available in smallholder farms with inorganic fertilizers and the importance of combining this with appropriate water harvesting techniques for increasing the yields of maize and beans in ASALs. The use of community based organizations to promote improved soil fertility and water-harvesting technologies could be the best way of increasing the adaptability and adoption of the technologies.

Acknowledgement

We are grateful to KARI and European Union for funding this project and the various farming communities in the six clusters for accepting to participate in the trials.

References

- Adetunji M.T. 1997. Organic residue management: Soil nutrient changes and maize yield in a humic Ultisol. *Nutrient Cycling in Agroecosystems* 47: 189–195.

- Defoer T. and Budelman A. 2000. Managing soil fertility in the tropics. A resource guide for participatory learning and action research. Defoer T. and Budelman A (Eds.) Royal Tropical Institute, Amsterdam, The Netherlands/International Institute for Environment and Development, London, UK.
- Giller K.E., Cadisch G. and Mugwira L.M. 1998a. Potential benefits from interactions between mineral and organic nutrient sources. In: Waddington et al., (1998). *Soil Fertility Research for Maize-Based Farming Systems in Malawi and Zimbabwe*. The Soil Fertility Network for Maize-Based Cropping Systems in Malawi and Zimbabwe. Harare, Zimbabwe, June 1998. pp 155–158.
- Giller K.E., Gilbert R., Mugwira L.M., Musa L., Patel B.K., and Waddington S.R. 1998b. Practical approaches to soil organic matter management for smallholder maize production in Southern Africa. In: *Soil fertility Research for maize based farming systems in Malawi and Zimbabwe*. Harare, 139–153.
- Kapkiyai J., Karanja N., Woomer P.L. and Qureish N. 1998. Soil organic carbon fractions in a long-term experiment and the potential for their use as diagnostic assay in the highland farming systems of Central Kenya. *African Crop Sci. J. 6: 19–28*.
- Kapkiyai J., Woomer P., Qureish N., Smithson P. and Karanja N. 1996. Effect of fertilizer and organic inputs on soil organic matter and nutrient dynamics in a Kenyan nitisol. Paper presented at the International Symposium on Carbon and nutrient Dynamics in Natural and Agricultural Tropical ecosystems. Harare, Zimbabwe, 29th April to 4th May, 1996.
- Kute C.A.O. and Chirchir P. 2000. Effect of low levels of inorganic fertilizer and organic manure on yields of finger millet in Chobosta, North Rift Valley. Evaluation of organic and inorganic fertilizer for small holder maize production in North Rift Kenya. Participatory Technology Development for Soil Management by Small Holders in Kenya. Proceeding of the 2nd Scientific Conference of the Soil Management and Legume Research Network Projects. June 2000 Mombasa, Kenya.
- Obaga S.O., Maobe S.N. and Makini F. 2000. Evaluation of organic and inorganic sources of phosphorus for smallholder maize production in Kisii, South West Kenya. Participatory Technology Development for Soil Management by Small Holders in Kenya. Proceeding of the 2nd Scientific Conference of the Soil Management and Legume Research Network Projects. June 2000 Mombasa, Kenya.
- Onyango R.M., Mwangi T.J., Kiiya W.W., Kamidi M.K. and Wanyonyi M.W. 2000. Evaluation of organic and inorganic fertilizer for small holder maize production in North Rift Kenya. Participatory Technology Development for Soil Management by Small Holders in Kenya. Proceeding of the 2nd Scientific Conference of the Soil Management and Legume Research Network Projects. June 2000 Mombasa, Kenya.
- Oweis T. 1994. Supplementary irrigation: A highly efficient water use practice. Aleppo, Syria. International Centre for Agricultural Research in the Dry Areas.
- Oweis T. and Taimeh. 1996. Evaluation of a small basin water harvesting system in the arid region of Jordan. *Water Resources Management 10:21-34*.
- Palm C.A., Myers R.J.K. and Nandwa S.M. 1997. Combined use of organic and inorganic nutrient sources for Soil Fertility Maintenance and Replenishment. In replenishing. *Soil Fertility in Africa*. SSSA Special Publication, No. 51.
- Perrier E.R. 1990. Water capture schemes for dryland farming in challenges agriculture A global perceptive proceeding of the international conference on Dryland Farming, Bushland, Texas, eds. P.W. Unger, W.R. Jordan, T.V. Sneed and R.W. Jensen. USA: United States Department of Agriculture.
- Simpson J.R., Okalebo J.R. and Lubulwa G. 1996. The Problem of Maintaining Soil Fertility in Eastern Kenya: a review of relevant research. *ACIAR Monograph no. 41*.
- Smaling E.M.A. 1993. Soil Nutrient Depletion in Sub-Saharan Africa. In: van Reuler H. and Prins W.H. (eds) *The role of plant nutrients for sustainable crop production in Sub-Saharan Africa* pp. 53–67. Dutch Association of Fertiliser Producers, Leidschendam, the Netherlands.
- Smaling E.M.A., Nandwa S.M., Prestele H., Roetter R. and Muchena F.N. 1992. Yield Response of Maize to Fertilisers and Manure under Different Agro-ecological Conditions in Kenya. *Agric. Ecosy. and Env. Vol 41: 241–252*.
- Suleman S., Wood M.K., Shah B.H and Murray L. 1995. Rainwater harvesting for increasing livestock forage on arid rangelands of Pakistan. *Journal of Range Management 48: 523–527*.
- Watiki J.M., Gichangi E.M., Itabari J.K., Karuku A.M. and Ngululu S.N. 1999. The effect of rate and placement of boma manure on maize yield in semi-arid Eastern Kenya. Proceeding of the 6th Biennial Scientific conference. Agricultural Research and Development for Sustainable Resource Management and Increased Production. KARI Headquarters, Nairobi.
- Woomer P.L., Bekunda M.A., Karanja N., Morehouse T. and Okalebo J.R. 1998. Agricultural resource management by smallholder farmers in East Africa. *Nature and Resources 34(4): 22–33*.

Profitability of agro-forestry based soil fertility management technologies: the case of small holder food production in Western Kenya

J. M. Maithya · L. N. Kimenye · F. I. Mugivane · J. J. Ramisch

Abstract Persistent food insecurity accompanied by low and declining farm household incomes are a common feature of many small holder maize and bean producers in western Kenya. This has been largely attributed to soil nutrient depletion, among other factors. One way of addressing soil fertility problems in many maize-based cropping systems is the use of agro-forestry based technologies. We carried out a survey in western Kenya (Vihiga and Siaya districts) aimed at analyzing the financial and social profitability of use of agroforestry based (improved tree fallows) and other soil fertility management technologies among small-holder farmers. The Policy Analysis Matrix (PAM) was used to determine the financial and social profitability of different production systems, which were categorized on the basis of the technology used to address soil fertility. Farm budgets were first prepared and in turn used to construct the PAMs for six production systems

namely: maize–bean intercrop without any soil fertility management inputs; maize–bean intercrop with chemical fertilizers only; maize–bean intercrop with a combination of chemical fertilizers and improved fallows; maize–bean intercrop with improved fallows only; maize–bean intercrop with a combination of improved fallows and rock phosphate; and maize–bean intercrop with Farm Yard Manure (FYM) only. Results revealed that use of chemical fertilizers with improved fallows was the most profitable technology and thus the study recommended that farmers be encouraged to intensify the use of chemical fertilizers. To make chemical fertilizers more accessible to farmers, the study also recommended that good linkages be made between farmers and micro credit institutions so that small scale farmers are not actually biased against due to lack of collateral when credit is being advanced to clients.

Keywords Food insecurity · Soil nutrient depletion · Improved fallows · Financial profitability · Social profitability · Food production

J. M. Maithya (✉)
USAID-Kenya Horticultural Development Program,
P.O. Box 3074 (00506), Nairobi, Kenya
e-mail: jmaithya@fintrac.com

L. N. Kimenye · F. I. Mugivane
Department of Agricultural Economics, University of
Nairobi, P.O. Box 29053, Nairobi, Kenya

J. J. Ramisch
Tropical Soil Biology and Fertility Institute (TSBF-CIAT),
P.O. Box 30677, Nairobi, Kenya

Introduction

Background information

Most countries in sub-Saharan Africa are faced with persistent food insecurity accompanied by

This article has been previously published in the journal “Nutrient Cycling in Agroecosystems” Volume 76 Issues 2–3.

low and declining farm incomes. This has been attributed to low and declining agricultural production and productivity (World Bank 1996). Agriculture, being the dominant sector in Kenya, plays a big role both as a source of food and for household income. Given that the population growth rate has been substantially higher than the growth rate in agriculture, both per-capita food production and incomes have persistently declined resulting in recurrent food crisis and worsening rural poverty (Republic of Kenya 2002). To meet food security needs of the population, agricultural productivity must grow at a rate that exceeds the population growth. Therefore, in Kenya the determination of strategies, which could steer agricultural and food productivity to higher and sustainable levels are major concerns in agricultural policy and programming.

Soil fertility depletion in smallholder farms is the fundamental biophysical root cause of declining per-capita food production in Africa (Sanchez and Jama 2000). No matter how effectively other constraints are remedied, per-capita food production in Africa will continue to decrease unless soil fertility depletion is effectively addressed. In Kenya for example, studies have shown that low and declining soil fertility due to soil erosion and continuous cropping is behind the current low food production, low land productivity, food insecurity and poverty among most of the rural households (Jama et al. 1999; Sanchez and Jama 2000). Farmers themselves have persistently expressed that low soil fertility is a major constraint to food crop production (Sanchez and Jama 2000).

With the deregulation of fertilizer prices and grain marketing in Kenya in the early 1990s, fertilizer use has been low with smallholder farmers being unable to apply the recommended levels. This was as a result of the drastic price increase resulting from both the withdrawal of fertilizer price subsidies by the government and the devaluation of the Kenyan shilling. In Kenya, fertilizer use patterns to address soil fertility are marked by high concentrations on major cash crops as opposed to food crops. This is partially because average returns to fertilizer use are higher in cash crops than in food crops.

The declining soil fertility has compelled researchers and international organizations

interested in agriculture to focus on identifying alternative and/or supplementary strategies for improving soil fertility. Over the last 10 years, the International Center for Research in Agro-forestry (ICRAF) and the Tropical Soil Biology and Fertility institute (TSBF) have carried out research trials on alternative soil fertility replenishment technologies with farmer% in western Kenya. Technologies being actively and vigorously promoted to farmers in the region include; agro-forestry-based technologies (improved tree fallows), *Minjingu* rock phosphate and Farm Yard Manure (FYM). These technologies have been found to be both technically feasible and socially acceptable (Sanchez and Jama 2000; Jama et al. 1999).

Problem statement

In the 1970s and 1980s, expansion of food production especially maize in Kenya relied heavily on use of chemical fertilizers. This is the period when hybrid maize technology was introduced and was accompanied by dependence on chemical fertilizers as part of the recommendation package (Hassan et al. 1998). At that time smallholder farmers had every reason to adopt the hybrid maize and use chemical fertilizers because their prices were kept favorable through government subsidies and controls. Following liberalization of fertilizer prices and grain marketing in the 1990s, prices increased drastically. As a result, use of chemical fertilizers to address soil fertility problems decreased (Heisey and Mwangi 1995). This in turn resulted in decline in food production and productivity leading to chronic food insecurity (World Bank 1996). A lot of questions have then emerged on the economic sustainability of food production by sole and heavy reliance on chemical fertilizers to address soil fertility problems. Additionally, farm sizes have been decreasing due to population pressure inevitably resulting into continuous cropping and as a consequence, leading to soil nutrient depletion.

Due to the socio-economic profile of smallholder farmers, soil fertility research needs to address alternative sources of soil fertility management strategies that are not only costeffective but still competitive in terms of productivity and generation of farm income. Most studies done by ICRAF and

other organizations have used pilot farmers to look at the financial attractiveness of these technologies using cost benefit analysis (Franzel 1999; Place et al. 2000; Kwesiga et al. 1999; Rommelse 2000). Other studies have also been done looked at both the potential for and factors affecting the adoption of some of these technologies.

This study sought to provide quantitative and empirical evidence of the financial and social profitability (hence the viability) of the above-mentioned emerging technologies for soil fertility enhancement using non-pilot farmers. Financial profitability refers to the difference between total revenues and total costs measured in observed market prices. This concept was used to show whether individual farmers have financial incentives to intensify the use of the soil fertility management technologies being studied. Social profitability on the other hand, refers to the difference between total revenues and total costs measured using efficient (social) prices. This concept was used as measure of whether resources in the region were being used efficiently to produce food under the technologies of interest.

Objectives

The overall objective of the study was to determine the profitability of both agro-forestry based and *Minjingu* Rock Phosphates as soil fertility enhancement technologies for smallholder food production.

The specific objectives were,

- To determine the financial profitability of food production under the use of improved fallow trees, *Minjingu* rock phosphate and farm yard manure as alternative soil nutrient replenishment technologies.
- To determine the social profitability of food production under the use of improved fallow trees, *Minjingu* rock phosphates and FYM as alternative soil nutrient replenishment technologies.

Literature review

Several studies both in and outside Kenya, have been carried out on the subject of soil nutrient

depletion (Nekesa et al. 1999; Kamanga et al. 1999). Nekesa et al. (1999) did a study on the economics of improving household food security through targeting the nutrient depleted soils of western Kenya. They considered PREP-PAC, a soil fertility replenishment product specifically designed to ameliorate nutrient depleted “patches” in maize fields. Kamanga et al. (1999), looked at how intercropping perennial legumes purposely for addition of green manure to maize production in southern Malawi. They found out that use of *sesbania* realized the highest maize yields (2,937 kg per ha) followed by *tephrosia* (2,592 kg per ha) and then pigeon peas (2,109 kg per ha). Although at a glance, it is clear that productivity increased, it is unclear whether producing maize under such technologies was profitable. In another soil fertility study by Nyirongo et al. (1999) focusing on compost and igneous phosphate rock amendments in Malawi, it was noted that acid soils contributed to the problem of phosphorus deficiency. The study concluded that rock phosphate was potentially capable of offering an inexpensive source of phosphorus. Several studies have successfully made use of the Policy Analysis Matrix (PAM) developed by Monke and Pearson (1989) to determine the profitability of commodity production systems. For example, Adesina and Coulibaly (1998) used the Matrix to analyze the competitiveness of agro-forestry based soil fertility management technologies for maize production in Cameroon.

Data and methods

The Policy Analysis Matrix (PAM) method, a logical framework for policy analysis was developed in the late 80s and early 90s by Scott Pearson of the Food Research Institute, Stanford University, and explained in details in Monke and Pearson (1989). This framework was used to measure the financial and social profitability of food production under different soil fertility management technologies. Underlying this model (Table 1), is the assumption that prices reflect values or can be adjusted to do so (Gittinger 1982).

Table 1 A schematic presentation of the PAM

	Revenues	Costs		Profits
		Tradable	Domestic	
Private values	A	B	C	D
Social values	E	F	G	H
Divergences	I	J	K	L

Adapted from Monke and Pearson (1989)

Notes:

Private profits (D) = A - (B + C)

Social profits (H) = E - (F + G)

Output transfers (I) = A - E

Input transfers (J) = B - F

Factor transfers (K) = C - G

Net transfers (L) = D - H = I - (J + K)

Observed market prices were used for financial analysis. Since market prices do not always do a good job in reflecting social values due to market failures then shadow (efficient) prices were used for analyzing social profitability.

Besides analyzing the effects of market failures on private profitability, the PAM can also examine the relative social profitability or social optimality of alternative economic activities. Another advantage of the PAM is that, instead of requiring time series data of prices and marketed quantities, which are often difficult to obtain in the developing country setting, it can use data from representative farms. It also allows easy presentation and interpretation of the results to policy makers and other users. The main limitation of the PAM is its static nature (Kydd et al. 1997). This means that it does not incorporate the effects of changes in the important variables over time. For the current study, the above-mentioned shortcoming was overcome by conducting a sensitivity analysis to determine the effects on profitability that would be caused by changes in some key variables.

The first row (private values)

PAM basically consists of three rows and four columns. The first row gives revenues, tradable input costs, domestic factor costs and profits valued using market or private prices. The term “private” refers to the observed prices of outputs and inputs. In the first row, the observed market prices are used

to value outputs and inputs. These prices contain the effects of any distorting policies and market failures. In this study, the observed market prices were (i) prices for maize and beans in the local markets (ii) input prices for FYM, chemicals for spraying, mineral fertilizers (urea, DAP and rock phosphate), seeds for maize, beans and improved fallow trees, as obtained in the nearest market centre (iii) wage rates for labour inputs into activities such as land preparation, planting, weeding, chemical application, fertilizer application, harvesting and carrying out post harvesting activities.

The letter (A) represents private revenue. Private revenue is a product of private prices and quantities of output produced under a given production system. The letter (B) represents tradable input costs valued at market prices. Tradable inputs such as fertilizers are inputs traded in the world market. The domestic factor costs are represented by letter (C) and are products of observed market prices and quantities of domestic factors employed in the production system under consideration. Domestic factor costs include land, labour and capital. Private profits, also known as financial Profits are denoted by letter (D) and are given by private revenue (A) less private costs of tradable inputs and domestic factors (B + C). Private profits are a measure of the financial competitiveness of the production system. Positive private profits indicate that the production system is financially competitive and producers have incentives to engage in that production system. If private profitability is too low or negative, then use of the particular soil management technology to produce food or a high value crop is expected to decline since farmers would have little or no financial incentives to continue or increase production under that system.

This approach was used to estimate private profitability of maize and bean (food) production under different soil fertility management technologies in western Kenya. Six different food production systems were considered. Each production system comprised of a food crop and a specific soil fertility management technology (Table 2).

Private profits were compared for food production under the six fertility management options being practiced in western Kenya. In

Table 2 Crops and technology packages being studied

Crop	Technology package
1. Maize–bean intercrop	Non-use of external inputs
2. Maize–bean intercrop	Use of chemical fertilizers only
3. Maize–bean intercrop	Use of farm yard manure only
4. Maize–bean intercrop	Use of improved fallows only
5. Maize–bean intercrop	Use of improved fallows + chemical fertilizers
6. Maize–bean intercrop	Use of improved fallows + rock phosphate

Source: Authors' survey, 2002

western Kenya, maize is normally intercropped with beans and therefore maize–bean intercrop was treated as a production system.

The second row (social values)

The entries in the second row are based on “social” prices. “Social” prices of outputs and production factors are the efficient prices that ensure efficient or optimal utilization of resources. This row gives revenue (E), tradable input costs (F), domestic factor costs (G) and net profitability (H) all valued using social prices. The social prices for tradable outputs and inputs are given by world prices, which exclude distorting effects of government policies such as subsidies and taxes, and effects of market failure. Social prices of tradable outputs and inputs were estimated from the world market prices. For example, in the present case maize and fertilizer prices were estimated from the Cost Insurance and Freight (c.i.f.) import prices. Social profitability (H), the difference between revenues (E) and costs (F + G) is a measure of how efficient farmers' resources in the region were being utilized for food production under the different soil fertility management technologies. Financial profitability cannot be used to show whether resources are utilized efficiently because observed market prices are very often distorted. Distorted prices don't reflect scarcity values of resources and therefore cannot lead to optimal allocation of resources.

Positive social profitability implies that the production system is economically attractive and that on the whole, resources are being employed efficiently. Negative social profitability on the other hand implies that the production system in question is not economically attractive. Social profitability was used to show whether resources (land, labour and capital) at the disposal of farmers were being efficiently utilized to produce food using such technologies.

Estimation of social prices for output

The import parity price rather than the export parity price was considered as the most appropriate social price. This was because first, Kenya has been importing maize in the recent past and secondly, Kenya has adopted the policy of import substitution meaning that maize is produced primarily for domestic consumption. The domestic transportation and handling costs were added to the border prices (cost, insurance and freight) to arrive at a social price equivalent for maize at the study area.

According to Morris (1989), decisions based on production levels have a long run perspective, and therefore long term trend c.i.f. and free on board (f.o.b.) prices should be used in calculating import and export parity prices respectively. Long-term price trends prices also reduce the effects of short-term price fluctuations observed in marketing of agricultural produce. Since world prices vary from year to year, the current study estimated the long-term trend world prices by computing the average prices using the 1995–2001 world prices (Table 3).

World prices are usually quoted in foreign currency. An efficient exchange rate is used to convert the prices from foreign to domestic currency equivalent. One approach is to estimate and apply a shadow exchange rate. In 1993, the Kenya shilling exchange rate was allowed to float freely to encourage market allocation of foreign exchange and to promote efficient utilization of scarce resources. Since then, the government has continued to maintain a competitive and a market determined exchange rate policy. It was also noted that in the absence of controls in the foreign

Table 3 World market prices in US dollars per ton for DAP, urea and white maize

Year	DAP	Urea	White maize
1995	208.7	228.0	123.0
1996	219.6	220.5	165.0
1997	200.4	116.4	92.3
1998	198.1	130.2	102.0
1999	199.5	77.4	90.3
2000	150.1	90.0	96.0
2001	165.5	114.6	85.2

Source: FAO, Food outlook statistical supplement (2002)

exchange market, exchange rate moves with the supply and demand forces and thus the prevailing exchange rate was considered to be competitive and therefore used as the social exchange rate. For the current study, a twelve-month average exchange rate of 78.6 for the year 2001 as base year was adopted as the social exchange rate.

For maize, world market price equivalent was estimated and used as the social price. The observed domestic transportation and handling costs were added to the border prices of imported maize to obtain the social price equivalent to its import parity price (Appendix 1). The internal handling costs were costs at the port of Mombasa mainly related to related to off loading and storage before clearing and transportation. An average of such costs was got from the customs department. Transport costs were considered all the way from the port of Mombasa to the market (Luanda) where farmers commonly bought maize for domestic consumption.¹ The following formula was applied to derive its social price;

$$P_m = (P_{cif} * ER) + IC + TC$$

Where;

P_m = the social price of maize;

P_{cif} = the cif (trend) price for maize at Mombassa;

ER = foreign exchange rate;

IC = internal handling costs;

TC = transportation costs from the port of Mombasa to western Kenya

¹ Farmers in western Kenya were found to be net buyers of food. They consumed almost all the maize produced and supplemented the same by buying from the market.

Since Kenya some times imports yellow maize, a factor of 1.1 was used to correct for quality differences between yellow maize (which Kenya imports sometimes) and white maize (which is normally grown in Kenya).

Estimation of social prices for tradable inputs

Production inputs were first classified into tradables, non-tradable inputs and domestic factors. Social prices were determined differently for these tradables, non-tradable production inputs and domestic factors. Social prices of tradable inputs (imported fertilizers—urea and DAP) were estimated using a similar procedure like that used for maize. Unlike the case for maize, whereby the transport costs considered were from the port of Mombassa, up to the central market in western Kenya, for chemical fertilizers the transport costs were considered all the way up to the farm (past the central market). This is because fertilizers are used at farm level (Appendix 2). Similarly, the official exchange rate was assumed to represent the social exchange rate. The import parity price was used as the efficient price because Kenya is a net importer of inorganic fertilizers.

Estimation of social prices for non-tradable inputs

Concerning non-tradables, there is no particular method of arriving at their social prices. Non-tradable inputs contain both tradable and domestic factor components. One way of arriving at the social price equivalent of a non-tradable input is by adding subsidies and subtracting taxes from its private price (Morris 1989). In the current study, improved fallow seeds and FYM were considered to contain a tradable component and a capital component and to arrive at their social prices, a rule of thumb was employed. This rule of thumb presupposes that private market costs be decomposed evenly into one third labour, one third capital and one third tradable. The social price for beans was taken as the opportunity cost (cost of the next best alternative crop) which was maize while the social price for *Minjingu* Rock Phosphate was taken as the

opportunity cost (cost of the next best alternative fertilizer) which was DAP (Table 5).

Estimation of social prices for domestic factors

The social prices for domestic factors (land, labor and capital) are represented by opportunity cost (Morris 1989). In principle the social value of land should be equal to its highest alternative production use (Gonzales et al. 1993). It could also be estimated from its rental value where a competitive market for leasing or renting land exists. The current study did not factor in the cost of land during both private and social valuation because it is a permanent asset and its inclusion over estimates the costs and under estimates the profits. For capital items, the social price was the opportunity cost of capital, which was estimated by the real interest of borrowing from lending institutions (Monke and Pearson 1989). The interest rate is the payment for use of capital. The social price of capital is the opportunity cost of money i.e. the marginal productivity of additional investment in the best alternative use (Gittinger 1982). The real interest rate is nominal interest rates (observed interest rate) less the rate of inflation in the country. The following formula was used to estimate the real interest rate;

$$Ir = \{(1 + In)/(1 + f)\} - 1$$

Where,

Ir = real interest rate;

In = nominal interest rate;

f = inflation rate

The current study used 14.5% as the real interest rate for the 2001 base year (Table 4).

Table 4 Estimation of real interest rate on commercial bank loans and advances

Year	Nominal interest rate	Inflation rate	Real interest rate
1997	30.4	11.2	19.2
1998	27.1	6.6	20.5
1999	25.2	3.5	21.7
2000	19.6	6.2	13.4
2001	22.5	8.3	14.5

Source: Authors computations, 2002

In general, the shadow price for farm labour is simply the marginal value product, which is the marginal output of labour foregone elsewhere because of its use in the production activity under consideration (Monke and Pearson 1989). In a perfectly competitive economy, the shadow price of labour would be equal to the wage rate. Past studies have shown that agricultural labour market in Kenya is highly competitive, that is, the wage rate reflects supply and demand conditions (Place et al. 2000). As such, the current study retained the observed daily wage rate (Ksh 101) as the shadow price of labour.

Sensitivity analysis

As noted earlier on, PAM framework gives results that are static in nature. To overcome this shortcoming, a sensitivity analysis was carried out. This analysis provides a way of assessing the impact of changes in key assumptions on profitability. It is usually useful in any ordinary profitability analysis to have an idea of whether the economic optimum value of interest represents a relatively large positive balance between small costs and benefits. Additionally, it is good to know these economic optimum values represent a relatively small balance between very large costs and benefits. In a liberalized economy, the value and costs of the output and the inputs are most likely to fluctuate. The stability of economic optima values of interest were noted by observing the effects of varying output values and input costs up and down within a range of about 10%. The price of improved fallow seeds was increased by 10% and profitability level before and after the increase compared. Similarly, the prices of maize and beans were decreased by 10% and profitability before and after the decrease compared.

Study area

This study was carried out in western Kenya. This part of the country was chosen because of its high population, which has led to continuous cropping. Additionally, these areas have experienced serious soil fertility problems (Jama et al. 1999). It is also in the same areas where the Tropical Soil

Table 5 Prices used for the valuation of outputs and inputs

	Private	Social
Output/inputs	Ksh/kg (1US\$ = Ksh 78.6)	Ksh/kg (1US\$ = Ksh 78.6)
Maize (average price)	10.00	15.10
Beans (average price)	20.00	10.00 (the price of maize)
Maize (highest price)	12.50	–
Beans (highest price)	35.60	–
Maize (lowest price)	8.40	–
Beans (lowest price)	18.06	–
DAP	28.00	28.10
Urea	24.00	24.00
Farm Yard Manure	25.00 per wheelbarrow	Was decomposed
Improved fallow seeds	100.00	Was decomposed
Rock phosphate	15.00	28.00 (the price of DAP)
Labour (daily wage)	101.00	101.00 (competitive market)

Source: Authors' survey and computations, 2002

Biology Fertility (TSBF) Institute and International Centre for Research in Agro forestry (ICRAF) scientists have been doing research and on-farm trials together with vigorously promoting the various technologies under consideration to non-pilot farmers.

The specific areas of study are located around Maseno town (0° 00' N 34° 35' E) and include adjacent portions of Siaya and Vihiga districts i.e. Yala and Emuhaya divisions. These represent humid parts of the food-crop based land use systems of western Kenya. The area has high agricultural potential (high rainfall and well structured soils) but the land is nutrient depleted. There are two cropping seasons, the long rains that run from March to July and the short rains, which run from August to November. The rainfall amounts range between 1,500 and 1,900 mm per annum, the altitude ranges between 1,250 and 1,600 m above sea level while the mean temperature is 21.0° C (Rommelse 2000).

Farm sizes vary from 0.5 to 2.0 ha with a median of 1.2 ha while main soil types are Ferrasols, Acrisols, and Nitisols. Population densities range from 300 to over 1,000 persons per square kilometer while main ethnic groups in Siaya and Vihiga districts are Luo and Luhya respectively (Rommelse 2000). The main food crop in the study area is maize, which is usually intercropped with beans. Other common food crops include tomatoes, bananas, kales, cassava and sweet potato.

Data sources and sampling

The study used both primary and secondary data for maize, beans and soil fertility management technologies. The primary data that was collected using structured questionnaires was about output prices and quantities as well as prices and quantities of soil fertility management technologies such as improved fallow trees, chemical fertilizers and Minjingu rock phosphates. This primary data was obtained through interviewing randomly selected farmers. The secondary data was about exchange rates, nominal lending interest rates, inflation rates and f.o.b. prices for tradables (maize and fertilizers). This secondary data was collected from Food and Agricultural Organization (FAO) publications (food outlook and statistical abstracts), publications from the planning and farm management division of the Ministry of Agriculture and Rural Development (MoARD), statistical bulletin, annual reports and monthly economic reviews from the Central Bureau of Statistics/Central Bank of Kenya.

The sample for this study was drawn from Yala and Emuhaya administrative divisions of Siaya and Vihiga districts respectively. To scientifically arrive at the specific farmers to be interviewed, a two-stage sampling procedure was used. In the first stage, the abovementioned divisions were purposively chosen because that's where most of the ICRAF and TSBF sites are located. In the second stage, two lists of farmers for both divisions were

obtained from the division officers. Both ICRAF and TSBF staff helped in ensuring that the lists comprised of farmer who had tried to use the agro-forestry based technologies once. These two lists were combined together giving a sampling frame of 363 farmers. Numbers were allocated against each of the farmers comprising the sampling frame and to get the actual respondents, the numbers were picked from a box one at a time. From the sampling frame, a total of one hundred and twenty farmers (120) were selected, sixty (60) coming from each of the two administrative divisions.

Results and discussion

Farm budgets

Farm budgets were developed for the six different soil fertility replenishment technology packages. The wage paid for casual labour in western Kenya did not vary per activity or per season. The average daily wage was Ksh 101 and includes a meal approximated at Ksh 30. Table 5 shows both the private and the social prices used for the valuation of output and inputs. All costs and returns are presented on per hectare basis for one year (2 seasons).

The food production system (maize–bean intercrop) which recorded the highest total revenue (Ksh 20,936) was the use of a combination of chemical fertilizers alone followed by use of chemical fertilizers in combination with improved fallows whose total revenue was Ksh18,401 (Table 6). The production system that registered the highest total revenue similarly had the highest net private profits.

Financial profitability

PAMs for the different soil fertility management technologies were constructed. Values in the first row of the PAM, which gives the net private profitability, were computed using observed market prices. Financial profits, also known as net private profits are equal to the total revenue less total costs. Financial profitability shows the profitability of a production system, given the current technology, output values, and input costs. In regard to food production, the highest financial profits of Ksh 11,735 for use of a combination of chemical fertilizers alone (Table 7). Further, the total costs were decomposed into both tradable inputs (in this case chemical fertilizers) and domestic factors.

Farm budget analysis showed all production systems for food production had positive private profits. Therefore, all the systems were all financially profitable at observed market prices. Since net private profitability is a direct measure of the incentives for farmers to produce a commodity under a given technology, the results of this study suggest that farmers in western Kenya have financial incentives to expand food production by use of all the technology packages that were considered. In general, technology packages that comprised of chemical fertilizers appeared to be more attractive financially to farmers relative to other soil fertility management options for the production of food.

Social profitability

Social profitability, which is equal to social revenue minus social costs, is a measure of how efficiently resources are utilized. Both output and

Table 6 Total revenue, costs and profits (Ksh/ha)

Technology	Farmers	Total revenue (average)	Total costs (average)	Profits
M/B + 0	10	15,226.00	8,200.50	7,025.50
M/B + F	23	20,936.20	9,201.33	11,734.87
M/B + F + IF	35	18,401.26	8,613.97	9,787.29
M/B + IF	17	13,099.00	9,102.00	3,997.00
M/B + IF + RP	23	14,870.00	9,213.50	5,656.50
M/B + FYM	12	16,990.00	8,600.00	8,390.00

Source: Authors computations, 2002

Notes: M/B = maize–bean intercrop; M/B + 0 = maize–bean intercrop with no external inputs; F = Chemical fertilizers; IF = Improved fallows; RP = Rock phosphate; FYM = Farm Yard Manure

Table 7 Financial profitability (Ksh/ha)

Technology	Total revenue	Tradable inputs	Domestic factors	Profits
M/B + 0	15,226.00	–	8,200.50	7,025.50
M/B + F	20,936.20	1,597.16	7,604.17	11,734.87
M/B + F + IF	18,401.26	931.34	7,682.63	9,787.29
M/B + IF	13,099.00	–	9,102.00	3,997.00
M/B + IF + RP	14,870.00	330.00	8,883.50	5,656.50
M/B + FYM	16,990.00	–	8,600.00	8,390.00

Source: Authors computations from the first row of the PAM model, 2002

Notes: M/B = maize–bean intercrop; M/B + 0 = maize–bean intercrop with no external inputs; F = Chemical fertilizers; IF = Improved fallows; RP = Rock Phosphate; FYM = Farm Yard Manure

inputs are valued at prices that reflect opportunity costs. The results are taken directly from the second row of the PAM. Social prices which were used for tradable inputs and output were, Ksh 20.10/kg, Ksh 28.10/kg and Ksh 15.10/kg for urea, DAP and maize respectively.

Results of social profitability analysis in regard to food production revealed that the most socially profitable system was use of a combination of chemical fertilizers with improved fallows (Ksh 8,131) followed by use of FYM manure only (Ksh 6,977). All the production systems had positive social profits meaning that all the systems utilized resources efficiently (Table 8).

Sensitivity analysis

The stability of economic optima values of interest were noted by observing the effects of varying output values and input costs up and down within a range of about 10%. Both the private and social parameters for the production of food (maize and beans) were subjected to sensitivity analysis. The cost of improved fallow seeds was increased by 10% and profitability levels before and after the

increase compared. For ease of understanding the results for all the categories of sensitivity analyses are presented separately.

Increasing the cost of improved fallows by 10% (from Ksh 100 to Ksh 110) decreased the profits by Ksh 10 since the seed rate (spacing) was the same across different systems. Farmers were using one kilogram of improved fallow seeds per hectare. For the combination of improved fallows with chemical fertilizers, use of improved fallows alone and a combination of improved fallows with rock phosphate, profits decreased by 0.10%, 0.25% and 0.18% respectively (Table 9). This means that the cost of improved fallow seeds is insignificant in terms affecting profitability thus use of such seeds is not a risky venture.

Decreasing the prices of maize and beans by 10% is equivalent to decreasing maize price by one shilling and that of beans by two shillings. Re-computing profitability using Ksh 9 instead of Ksh 10/kg and Ksh 18 instead of Ksh 20/kg changed profits by 10% (Table 10). This gives an indication that an increase in the cost of production could impact on profitability by the same magnitude.

Table 8 Results of social profitability (Ksh/ha)

Production system	Revenue	Tradable inputs	Domestic factors	Profits
M/B + 0	10,926	301	5,609	5,016
M/B + F	11,969	732	4,799	6,438
M/B + IF + F	16,244	1,086	7,021	8,131
M/B + IF	11,000	580	7,789	2,631
M/B + IF + RP	12,210	1,001	6,161	5,048
M/B + FYM	13,100	701	5,422	6,977

Source: Authors computation from the second row of the PAM model, 2002

Notes: M/B = maize–bean intercrop; M/B + 0 = maize–bean intercrop with no external inputs; IF = Improved fallows; F = Chemical fertilizers; RP = Rock phosphate; FYM = Farm Yard Manure; M/B = maize–bean intercrop

Table 9 Comparison of initial profits with profits obtained after a 10% increase in the cost of improved fallows seeds (Ksh/ha)

Technology	Revenue	Initial costs	New costs	Initial profits	New profits	% Change
M/B + 0	15,226.00	8,200.50	8,200.50	7,025.50	7,025.50	0.00
M/B + F	20,936.20	9,201.33	9,201.33	11,734.87	11,734.87	0.00
M/B + F+IF	18,401.26	8,613.97	8,623.97	9,787.29	9,777.29	-0.10
M/B + IF	13,099.00	9,102.00	9,112.00	3,997.00	3,987.00	-0.25
M/B + IF+RP	14,870.00	9,213.50	9,223.50	5,656.50	5,646.50	-0.18
M/B + FYM	16,990.00	8,600.00	8,600.00	8,390.00	8,390.00	0.00

Source: Authors computations, 2002

Table 10 Comparison of initial profits with profits obtained after a 10% decrease in the price of beans and maize (Ksh/ha)

Initial profits	New profits	% Change
15,226.00	13,703.40	-10.00
20,936.20	18,842.58	-10.00
18,401.26	16,561.13	-10.00
13,099.00	11,789.10	-10.00
14,870.00	13,383.00	-10.00
16,990.00	15,291.00	-10.00

Source: Authors computations, 2002

Conclusions and recommendations

Use of chemical fertilizers alone was the most financially profitable technology (Ksh 11,735) while a combination of chemical fertilizers with improved fallows was the most socially profitable (Ksh 8,131) technology. Use of FYM gave the second highest social profits (Ksh 6,977). One clear observation from the production systems is that use of chemical fertilizers enhanced both financial profitability while use non-chemical fertilizers enhanced social profits.

Whereas chemical fertilizers are beyond the reach of small-scale farmers due to their high prices, chemical fertilizers inevitably remain to be the main solution to soil nutrient depletion. This is partially because it is normally in a form that enables quick release of nutrient into the soil unlike organic fertilizers. In a resource poor setting, like that of smallholder farmers, the faster or sooner the benefits from a technology are realized, the better so as to address their current food or financial needs. In this light, policy should focus on making fertilizers affordable or even accessible through credit.

Acknowledgements We are so grateful to the Tropical Soil Biology and Fertility Programme and the Rockefeller Foundation's Forum for Agricultural Resource Husbandry for the financial support that made this work possible.

Appendices

Appendix 1 Estimation of import parity price in Ksh of Maize in Western Kenya, 2002

F.o.b. Gulf ports (Long term world price-six year average from 1996)	91.29
Yellow-white premium (10%)	9.13
Freight rate to E/Africa (US\$/ton)	10.30
Insurance (1% of C and F)	1.12
c.i.f. Mombasa (US\$/ton)	111.84
Exchange rate	78.56
Estimated c.i.f. Mombasa (Ksh/ton)	8,786.15
IDF fees (2.75% of Cand F) (Ksh/ton)	239.20
Stevedoring (Ksh/ton)	674.48
KPA shore handling (Ksh/ton)	408.65
Bagging (Ksh/ton)	317.40
Transport to warehouse (Ksh/ton)	245.19
Storage and handling charges (Ksh/ton)	98.08
Fumigation charges (Ksh/ton)	119.03
Agency fees (Ksh/ton)	81.73
Incidental charges (1% of C and F) (Ksh/ton)	86.98
Ports and customs overtime (Ksh/ton)	19.84
Trade levy (Ksh/ton)	11.11
Landed into store Mombasa (Ksh/ton)	11,087.84
Cost per 90 kg bag	997.90
Road haulage to Luanda market, western Kenya (Ksh/bag)	357.98
Import parity price; western Kenya (Ksh/90 kg bag)	1,355.88
Import parity price; western Kenya (Ksh/kg)	15.10

Source: Authors computations, 2002

Notes:

f.o.b = free on board

c.i.f. = cost, insurance and freight

IDF = import declaration form

KPA = Kenya ports authority

Appendix 2 Derivation of import parity prices in Ksh for chemical fertilizers at farm level in western Kenya, 2002

Fertilizer type	DAP ^a	Urea ^b
Long term world price (six year average: from 1996 to 2001)	188.85	124.85
Sea freight to E/Africa (US\$/ton)	33.00	24.00
Insurance @ 1% of f.o.b	1.88	1.25
Cost c.i.f. Mombasa (US\$/ton)	223.73	150.10
Exchange rate	78.56	78.56
Cost c.i.f. Mombasa (Ksh/ton)	17,576.23	11,791.74
IDF levy @ 2.75% of c.i.f price	483.35	324.27
LC @ 2%	351.52	235.83
KBS levy @ 0.2%	35.25	23.58
Stevedoring and bagging charges @ Ksh 1771/ton DAP and 668/ton Urea Clearing and forwarding @Ksh60/ton	1771.00	668.00
Transport to warehouse @ Ksh 290/ton	290.00	290.00
Storage costs/ton for 2 months (warehouse)	96.00	96.00
Port to warehouse handling costs @Ksh116/ton	116.00	116.00
Warehouse handling @Ksh260/ton	260.00	260.00
Transit loss @ 0.5% c.i.f/ton	87.88	58.96
Cost of bags (rebagging)	25.00	25.00
Miscellaneous/incidental costs@0.5% c.i.f-	87.88	58.96
Total Mombasa ex-warehouse/ton	21,240.21	14,008.10
Total Mombasa ex-warehouse/ 50kg bag	1,062.00	700.40
Road transport from Mombasa to Luanda in western Kenya	170.00	170.00
Per 50kg bag Parity price equivalent at Luanda per bag	1,232.00	870.40
Retailing margin (10% per bag)	123.20	87.40
Social price at Luanda	1,355.20	957.40
Transport to the farm	50.00	50.00
Parity price equivalent at farm level/bag	1,405.20	1,007.40
Parity price equivalent at farm level/kg	28.10	20.10

^a DAP is imported in bulk and bagged in Mombasa

^b Urea is imported in 50 kg bags

Source: Authors computations, 2002

Key:

f.o.b = free on board;

c.i.f = cost, insurance and freight;

LC = letter of credit;

KBS = Kenya Bureau of Standards;

IDF = import declaration form

References

- Adesina A, Coulibaly ON (1998) "Policy and competitiveness of agro-forestry based technologies for maize-production in Cameroon": An application of Policy Analysis Matrix. *Agricult Econ* 19:1-13
- Franzel S (1999) Socioeconomic factors affecting the adoption potential of improved tree fallows in Africa. *Agro Forest Syst* 47:305-321
- Gittinger JP (1982) Economic analysis of agricultural projects. The Johns Hopkins University Press, Baltimore and London
- Gonzales LA, Kasryno F, Perez ND, Rosegrant MW (1993) Economic incentives and comparative advantage in Indonesian food crop production. International Food Policy Research Institute, Washington, DC
- Hassan RM, Murithi F, Kamau G (1998) Determinants of fertilizer use and the gap between farmers yields and potential yields in Kenya In: Hassan RM (ed) Maize technology development and transfer, a GIS application for research planning in Kenya. CABI International, pp 175-192
- Heisey PA, Mwangi W (1995) Fertilizer use and maize production in sub-saharan Africa. *International Maize and Wheat improvement (CIMMYT)*. CIMMYT, Mexico
- Jama BA, Niang IA, Amadalo B, De wolf J, Rao MR, Buresh RJ (1999) The potential of improved fallows to improve and conserve the fertility of nutrient depleted soils of western Kenya In: Proceedings of the 6th Biennial KARI Scientific Conference (KARI) pp 133-144
- Kamanga BCG, Kanysma-Phiri GY, Minae S (1999) Inter-cropping perennial legumes for green manure additions to maize in southern Malawi. *Afr Crop Sci J* 7(4):355-365
- Kwesiga FR, Franzel S, Place F, Phiri D, Simwanza CP (1999) *Sesbania sesban* improved fallows in eastern Zambia. In: Jama B, Buresh RJ, Place FM (eds) *Sesbania tree fallows on phosphorus sites: maize yield and financial benefits*. *Agron J* 90:717-726
- Kydd J, Pearce R, Michael S (1997) Economic analysis of commodity systems: extending the policy analysis matrix to account for environmental effects and transaction costs. *Agricult Syst* 55(2):323-345
- Monke AE, Pearson RS (1989) The policy analysis matrix for agricultural development. Cornell University Press, Ithaca, USA
- Morris ML (1989) Guideline on determining the comparative advantage through DRC (Domestic Resource Cost) Analysis. Working paper No. 89/10, CIMMYT Economic Program, Mexico.
- Nekesa P, Maritim HK, Okalebo JR, Womer PL (1999) Economic analysis of maize-bean production using a

- soil fertility replenishment product (PREP-PAC) in Western Kenya. *Afr Crop Sci J* 7(4):585–590
- Nyirongo CV, Mughogho SK, Kumwenda SD (1999) Soil Fertility studies with compost and igneous phosphate rock amendments in Malawi. *Afr Crop Sci J* 7(4):415–422
- Place F, Wangila J, Rommelse R, de Wolf J (2000) Economics of Agro-forestry technologies in the pilot project area in Western Kenya. ICRAF, Nairobi, Kenya
- Republic of Kenya (2002) Interim poverty Reduction strategy paper for the period 2002–2003. Government printer, Nairobi
- Rommelse R (2000) Economic Assessment of Biomass Transfer and Improved fallow trials in Western Kenya. Natural Resource Problems, Priorities and Policies Programme Working Paper 2001-3. International Centre for Research in Agroforestry, Nairobi, Kenya
- Sanchez PA, Jama BA (2000) Soil fertility replenishment takes off in East and Southern Africa. ICRAF, Nairobi, Kenya
- World Bank (1996) African development indicators. World bank, Washington, DC

Integrated natural resources management a strategy for food security and poverty alleviation in Kwalei village, Lushoto district, Tanzania

Joel L. Meliyo^{1*}, K.F.G. Masuki and J.G. Mowo

¹ARI-Mlingano, P.O. Box 5088, Tanga, Tanzania, Tel: +255 27 2647647, E-mail: mlingano@iwayafrica.com or jlmeliyo@yahoo.co.uk; *Correspondence author

Abstract

A watershed participatory approach study was formulated with the objectives of integrating soil conservation, afforestation and improved/disease tolerant seeds technologies into farmers' practices in order to reduce degradation of natural resources hence improve community livelihood. Farmers identified soil erosion, low soil fertility and poor varieties as pressing constraints. Farmer researcher groups (FRG) were formed one for each, on soil conservation, tomatoes, cabbage, bananas and snap beans. Different groups were trained on aspects to be tested. During assessment FRG were interviewed using open and closed questions, key informant and focus discussions. Results showed that construction of conservation structures, which started with 24 increased to 98 farmers. Physical conservation measures opened were 6,958 m long infiltration ditches (Fanya juu) and 9,515m bench terraces. Furthermore, about 280 m long diversion channel was excavated while about 5,800 multipurpose trees were planted. In addition, vegetable growers including those in neighbourhood villages adopted use of improved tomato and bean seeds and banana germplasm. Livelihood indices showed that farmers who conserved their land had 3 to 5 folds yield increase. The informal and formal surveys revealed that 150 farmers purchased new bicycles, 11 and 80 bought mobile phones and diary cows respectively. Similarly, food security increased from 3 to 9 months $y r^{-1}$. This study concludes that participatory integrated natural resources management addresses farmers' priorities, which is poverty reduction and improved food security. Secondly, farmers opt easily for technologies with quick financial and food security return

Key words: Food security, Integrated, natural resource management, poverty alleviation

Introduction

Soil erosion is among the most challenging problems facing farmers and natural resources managers worldwide (Lal 1995). Huge areas once fertile lands have been rendered unproductive due to soil erosion. World's estimates show that of the total land area of 13.4×10^9 ha, about 2.0×10^9 ha (15%) has been degraded to some extent (World Resources Institute 1993), while 62% of the globe degraded lands is found in Asia and Africa (UNEP 1993). It is projected that by the year 2020 there will be yields reduction of 16.5% in African

alone (Lal 1995) deepening more the existing poverty and food insecurity in particular sub-Saharan Africa.

In Tanzania, soil erosion is likewise a major threat for agricultural production (Tenge et al. 1998; Kaihura et al. 1999). West and East Usambara highlands are among the areas mostly affected by soil erosion in Tanzania, with topsoil losses between 92 and 100 $t ha^{-1}$ (Ngatunga et al. 1984). The consequences of soil erosion apart from the fertile topsoil losses have been reduced crop yields, food deficiency, siltation of waterways, damage of various civic structures and loss of land value (Pfeiffer 1990; Kaswamila 1995).

Due to the associated negative effects the struggle to reduce and control soil erosion started long ago during colonial rule (Semgalawe 1998). In Usambara Mountains, the conservation measures that were introduced include bench terrace, strips of Napier grass and a lot of tree planting (Shelukindo 1995). In spite of the hard work done to address soil erosion in West Usambara highlands by various projects at different times such as Soil Erosion Control and Agroforestry Programme (SECAP) and Traditional Irrigation Programme (TIP), adoption of soil and water conservation measures promoted is still minimal (Kimambo 1991; Mshana 1992; Jones 1996). The historic efforts have not been successful because of the top down approaches that were used which did not give emphasis farmers' involvement during project formulation and planning of activities to be executed (Mowo et al. 2002).

The experiences and failures of the top down approaches to enhance adoption of soil and water conservation measures, have resulted to a catchment approach (CA) popularized by African Highlands Initiatives (AHI) in West Usambara. The unique force behind the catchment approach is the participation of all stakeholders in identification of needs for conservation and planning for water conservation. The CA concept comes from focal area the hydrological or geomorphologic catchment that disregards the farm boundaries. The approach involves sensitization and mobilisation of the community through different participatory approaches (Kirway et al. 2003). In the CA a multidisciplinary team of professionals, farmers, and other stakeholders are involved in participatory appraisal in which different constraints are identified and ranked in order of priority.

Thus the broad objective to improve land productivity of the slopes of Usambara Mountains through introduction of an integrated basket of technical options that include natural resources (soil, water sources and forests) conservation measures, multipurpose trees, fodder grasses, application of farmyard manure and use high yielding varieties for tomatoes, cabbage, banana and beans.

The objectives of the study were 1) to promote the establishments of soil conservation structures such Fanya juu, bench terraces and trash lines, 2) to introduce multipurpose trees (MPTs) and grasses for fodder, fuel-wood and stabilisation of the soil conservation structures, 3) to carry out experimentation of high yielding and diseases tolerant varieties for tomatoes, cabbage, beans banana and coffee, and,

4) to assess the impact of the technologies on soil conservation and improved livelihood of participating farmers.

Materials and methods

Initially a Participatory Rural Appraisal (PRA) was executed using the PRA (Chambers 1992) tools such community meeting, historical trends, transect walk, village resource map and venn diagram. Other tools used were wealth ranking (grouping) and focus group discussion. The community meeting was used to introduce the purpose of the project and the position of farmers in participatory approaches being equal partners who would determine the success of the project. Also, using community meeting farmers mentioned agricultural and social constrains and prioritised them using matrix ranking and or absolute scoring. Therefore, at the end the PRA recorded the entire social, economic, biophysical and physical snags of productivity and the immediate consequences. Farmers' problems were ranked according to their priorities, importance and preference. Soil erosion and use of poor yielding planting materials emerged most pressing.

Participatory (farmer-research-extension) field experimentation for different technical options involving different soil conservation measures making, planting improved seeds for tomatoes, cabbage, snap beans, bananas and coffee were established. The seeds were supplied by the project for experimental plots and additional seed were given on soft loan basis.

The ground work approach involved formation of the African Highland Initiative committee that was charged to foresee all execution activities of different sub-projects. Under this committee there were different disciplines farmer research groups (FRGs) each with a leadership team; involving chair, secretary and committee members whose number depended on the number of group members and distribution among the 12 hamlets of the village. There were farmer research groups for Tomatoes, cabbage, snap beans, banana, coffee and soil conservation measures. Each group went through a determined training covering among other things lay out, planting, management, and visual assessment of different treatments and record keeping. Farmers in conservation groups were taught basic soil knowledge including marking contours and hence different conservation measures depending on the degree of steepness. In addition, soil erosion indicators and local soil names were covered during the study.

Conservation work started in 1999, by forming one farmers' research groups (FRG) of 24 members which was split into three 8 member groups namely MOTO MOTO (roughly meaning ultra active); NGUVU KAZI (manpower), and UMOJA NINGUVU (unity is strength). All FRGS (different technological options) were sensitised about their respective test options. The groups were supplied with basic requirements. For instance, the soil conservation group was supplied with 24 hoes, 5 shovels, 5 axes and also spirit levels and its set, while the tomato group was given seeds and chemicals.

Farmers who initiated conservation activities immediately were given Napier grass (*Pennisetum purpureum*), Guatemala grass (*Tripsacum laxum*) which were planted on the edges to stabilize the conservation structures and provide fodder in future. Tours within and out of the study area were organized for group representatives or some individuals purposely to create awareness and boost working morale.

Three years later a follow up study was conducted to assess the impact of the project on the community. Scientific field observations and data were collected using formal and informal surveys methods (Upton and Dixon 1994) key informants and focus group discussion, open-ended and closed ended questionnaires and also farmers' assessments were used to collect both qualitative and quantitative data. The data was analysed using computer based programme MS. Excel.

Results

Soil and water conservation measures

Soil and water conservation measures were well accepted by most farmers in Kwalei village during the first three year of AHI project implementation. However, because soil conservation measures making is labour intensive, farmers developed order of importance: vegetative strips, bench terraces, fanya juu which are hillside ditches made by through excavated soils on upper part of the ditch; infiltration ditches; and cut-off drains. The number of farmers increased from 24 in 1999 when the project started to 98 farmers in 2002 (Table 1). To date, there are over 200 farmers in Kwalei alone whose fields have been marked. In addition, about 12,300 m of mixed vegetative strips, 9,515 m long bench terraces, 6,958 m fanya juu and infiltration ditches and 280 m diversion channels (cut-off

Table 1. Soil and water conservation measures in Kwalei village

Type of conservation measure	Coverage	
	(m)	(ha)
Vegetative	12300	4.5
Bench terrace	9515	3.8
Fanya juu and infiltration ditches	6958	2.8
Cut-off drains	280	na

drain) were constructed. Further, 5,800 different multipurpose trees were planted and three types of grasses were introduced. Besides, between 1,000 and 1,500 farmers in and outside Kwalei village were practising at least one of the introduced technologies e.g. vegetable growing and soil conservation or banana growing. The coverage of soil conservation during the study period is represented in Table 1.

Training of village technicians

The FRG was trained on the principles and criteria for selecting appropriate conservation interventions. They practically engaged in marking and constructing physical soil conservation structures, on spot training in their villages followed, whereby 24 farmers were well trained how to make different types of soil conservation measures and compost making. Also, 30 farmers for vegetables, banana and beans groups were trained on better crop husbandry, seed multiplication and integrated pest management, including use of botanicals. All groups received training on data recording and record keeping.

Yield response

Yield for all farmers who constructed soil conservation structures increased 2 to 5 times (Tables 2 and 3). Similarly milk production rose from 1 to 3 litres per milking time. The farmers also reported increased pasture for their animals, fuelwood and improved food availability.

Improved livelihood and food security

Results from focus group discussion indicated that, farmers who practised soil conservation and grew vegetables (tomatoes, cabbages, sweet paper) had sufficient food throughout the year or funds to purchase

Table 2. Effects of soil and water conservation measures on maize yield in experimental plots

Crop	Slope (%)	Crop yield			
		Control (kg ha ⁻¹)	Grass strip (kg ha ⁻¹)	Bench terrace (kg ha ⁻¹)	Fanya juu (kg ha ⁻¹)
Maize	32	1900	2400	3100	2400
	35	1400	1960	3400	3100
	59	1340	1300	1500	1400

Table 3. Comparison of maize yields between conserved and non-conserved soils

Farmers who conserved	Type of conservation	Yield in 100 kg bags ha ⁻¹	Farmers Not conserved	Yield in 100kg bags ha ⁻¹
A	F/Juu	4	I	1.5
B	B/terraces	7	J	1.5
C	F/Juu	6.5	K	3
D	B/terraces	4.5	L	2
E	B/terraces	6	M	2
F	B/terraces	3.5	N	1.5
G	B/terraces	7	G	0.5
G	F/Juu	2	G	0.5
	Mean		5.1	1.5

food. Crop yields increased 3 to 5 times. Livelihood analysis indicated that during the project period farmers in village practising some of the technologies introduced had bought 50 bicycles and built corrugate iron sheets houses. The results show that 11 mobile phones were bought and several farmers also married additional wives. Also, many farmers could send their children to school as well as dressing their family members smartly.

Discussion

Farmers in Kwalei village quickly adopted a combination of several technologies as demonstrated by the 4 times increase in the number (24) initiated into soil conservation practices in 1999 and (98) by 2002. Similarly over 200 farmers' fields had been marked for erosion control structures. They were equally adopting planting of multipurpose trees and grasses, including non-project participants who asked for seedlings and seeds. The positive response is attributed to the immediate benefits their counterparts of the FRG testified about yield increase, reduced soil erosion and improved quality and quantity fodder. Similar findings were reported in East Zambia (Franzel et al. 2002). Farmers also agreed that conservation measures ensured that the applied farmyard manure (FYM) remained in place unlike previously when it was washed to

valley bottoms. Yield Increase was possibly a result of improved reduced soil loss, moisture storage and applied farmyard manure. All the three soil and water conservation measures: grass strip, bench terraces, fanya juu qualitatively indicated to be effective in reducing soil losses. This is because the eroded sediments are deposited when they reach barriers like soil conservation measures. This is similar to observation by Temple (1972) who reported that Napier grass strip reduced surface runoff by 15% and soil loss by 45%. Van Dijk (2002) in Indonesia reported the reduction of surface runoff by 60% and soil loss by 70% by bench terraces.

Further, these technologies ensured food security and financial gains making their adoption attractive, as food insufficiency and poverty were the forefront priorities during the baseline survey. In addition, the project farmers were able to acquire other benefits such as building corrugate iron sheet houses, buying bicycles and a limited number had expensive items such as milling machine, a car and mobile phones. Evidently, the project positively impacted on the livelihood of the community particularly towards poverty alleviation.

It was however, observed that income levels were varied according to individuals, type of cultivation practised and possession of land in appropriate areas to grow vegetables and/or banana. Most of the beneficiaries were middle aged men who used family labour to work followed by young aged men who

could work communally. Regrettably more men than women benefited from the technologies especially financially mostly due to cultural beliefs that restrict women to own land. The old women and widows owning land by inheritance benefit the technologies through food security, but comparatively less financial gains.

Conclusions

Providing integrated technologies that consider farmers' priorities and preferences, particularly those addressing food insecurity and poverty are likely to be adopted. Money generating technologies such as tomato growing was immediately adopted while other technologies enhancing it like soil conservation structures was unquestionably adopted. Soil conservation measures as a technology was mostly adopted because it ensured better yields for cash, food crops and animal feeds. Participatory approaches make farmers feel developers and adopters of their own making.

Acknowledgement

The authors are grateful to the African Highland Initiative (AHI) for funding the study Ecoregional Programme. Staffs of AHI Lushoto Benchmark site in Tanzania provided assistance in data collection. Mr. Jerry Ngailo availed his personal laptop for timely delivery and success. Sincere gratitude goes to the farmers who were ever willing to share what they know with us, thank you very much. I appreciate very much the financial empowerment by AfNet TSBF to attend the historical Conference.

References

Chambers R. 1992. Rural appraisal: rapid relaxed and participatory. Discussion paper 311, Institute of Development Studies. Brighton, Sussex.

Franzel S., Phiri D. and Kwesiga F. 2002. Assessing the adoption potential of improved fallows in Eastern Zambia. In: Franzel S. and Scherr S.J. (Eds) *Trees on the farm: assessing the adoption potential of agroforestry practices in Africa*. pp. 37–64.

Jones S. 1996. Discourse on land degradation in the Uluguru Mountains in Tanzania. Evolution and influences. *Journal of Rural Studies* Vol. 12 (2): 187–199. Elsevier.

Lal R. 1995. Erosion-Crop Productivity Relationship for soils of Africa. *Soil Sci. J.* 59: 661–667.

Kaihura F.B.S., Kullaya I.K., Kilasara M., Aune J.B., Singh B.R. and Lal R. 1999. Soil quality effects of accelerated erosion and management systems in three eco-regions of Tanzania. *Soil Tillage Res.* 53: 59–70.

Kalaghe A., Misani T. and Johnson H. 1988. Conservation of catchment forest in the Usambara Mountains. *Journal of Tanzania Association of Foresters*(6) 37–47.

Kimambo I.N. 1991. Penetration and protest in Tanzania. The impact of the World economy in Pare 1860–1960. James Currey: London.

Kirway T.N., Lema N.M., Lyimo S.D., Kileo R.O., Kapange C. and Schrader T. 2003. Farming systems approaches. Training manual volume 1. Ministry of Agriculture and Food Security, Tanzania.

Mowo J.G., Mwihomeke S.T., Mzoo J.B. and Msangi T.H. 2002. Managing natural resources in the West Usambara Mountains: A glimmer of hope in the horizon. <http://www.mtnforum/resources/library/mowo02a.htm> of 24/12/2004.

Mshana R.R. 1992. Insisting upon people's knowledge to resist development, peasant communities as producers of knowledge for social transformation in Tanzania. Zulg, Frankfurt (Main) University.

Ngatunga E.L.N., Lal R. and Uriyo A.P. 1984. Effects of surface management on runoff and soil erosion from some plots at Mlingano, Tanzania. *Geoderma* 33: 1–12.

Pfeiffer R. 1990. Sustainable Agriculture in practice – The production potential and environmental effects of macro-contour lines in West Usambara Mountains, Tanzania. Ph.D Thesis. Hohenheim University, Germany.

Semgalawe Z.M. 1998. Household Adoption Behaviour and Agriculture Sustainability in the Northern Mountains of Tanzania. The case of Soil Conservation in the North Pare and West Usambara Mountains. Ph.D Thesis. Wageningen Agricultural University, Wageningen.

Shelukindo H. 1995. Technical recommendations for soil and water conservation measures and agroforestry systems jointly developed by SECAP and TIP. Biological and physical soil and water conservation measures. DALDO Lushoto.

Temple P.H. 1972. Measurements of runoff and soil erosion at an erosion plot scale with particular references to Tanzania. *Geografiska Annaler* 54A: 203–220.

Tenge A.J.M., Kaihura F.B.S., Lal R. and Singh B.R. 1998. Erosion effects on soil moisture and corn yields on two soils at Mlingano, Tanzania. *American Journal of Alternative Agriculture* 13: 85–91.

UNEP (United Nations Environmental Program). 1993. Agricultural sustainability. *Desertification Control Bulletin* 23: 7–14.

Upton M. and Dixon J.M. (Eds). 1994. Methods of micro-level analysis for agricultural programme and policies. A guideline for policy analysts. FAO: Rome.

World Resources Institute. 1993. Towards sustainable development. A guide to the global environment. Washington, DC.

Van Dijk A.I.M. 2002. Water and sediment dynamics in bench-terraced agricultural steep lands in West Java, Indonesia. Ph.D Thesis. Free University, Amsterdam.

Effects of total inorganic nitrogen and phosphorus availability on Maize Yields in the First post *Tephrosia vogelii* fallow

Mkangwa C.Z.^{1*}, Maliondo S.M.S.² & Semoka J.M.R.³

¹Agricultural Research Institute Ilonga, P.O. Box 33, Kilosa, Tanzania. Tel: 255-0784828613, 255-023-2-623283; Fax: 255-023-2-623284, E-mail: mkangwa@yahoo.co.uk; ²Department of Forest Biology, P.O. Box 3010;

³Department of Soil Science, P.O. Box 3008, Sokoine University of Agriculture, Morogoro, Tanzania.

Abstract

A field experiment assessing the effects of natural and *T. vogelii* fallows and Minjingu phosphate rock (MPR) on total inorganic N, Pi-P and maize grain yield was conducted for 26 months in acidic, N and P deficient Ferralsols. In the first 22 months, natural and *T. vogelii* fallows were established, with the latter amended with either 0 or 80 kg P ha⁻¹ as MPR at planting. Subsequent to the fallows, maize was planted on plots treated with natural fallow, *T. vogelii* biomass, *T. vogelii* biomass co-applied with MPR, *T. vogelii* biomass pre-applied with MPR at *T. vogelii* establishment, Sulphate of Ammonia alone or co-applied with either MPR or TSP. Total inorganic N concentrations were monitored at planting and at vegetative and silking maize growth stages, whereas Pi-P was determined once at silking. Initially, total inorganic N concentrations were significantly ($P \leq 0.05$) higher in plots amended with *T. vogelii* biomass, with significantly ($P \leq 0.05$) highest values in plots treated with MPR at establishment of *T. vogelii* fallows. During vegetative and silking growth stages, total inorganic N concentrations were significantly ($P \leq 0.05$) higher in S/A treated plots. The Pi-P concentrations were significantly ($P \leq 0.05$) increased in plots amended with MPR, TSP and *T. vogelii* fallow biomass. Maize grain yield was significantly increased by *T. vogelii* fallow biomass applied alone or co-applied with MPR at maize planting, but significantly ($P \leq 0.05$) highest yield was obtained in plots that were treated with MPR at *T. vogelii* fallow establishment. Application of MPR to *T. vogelii* at planting is a better strategy for improvement of total inorganic N, Pi-P and maize grain yield in acidic, N and P deficient Ferralsols

Key words: maize grain yield, Minjingu phosphate rock, *Tephrosia vogelii*, Pi-P, total inorganic-N

Introduction

Nitrogen and phosphorus are the most limiting nutrients for crop production in many areas in sub Saharan Africa (SSA). The problem is more severe in soils that are high in P fixation and low in cation holding capacities like Ferralsols. In SSA, P fixing soils occupy about 35% of the land surface (Eswaran *et al.* 1997). Oldeman *et al.* (1992) estimated that about 62 million hectares in SSA are affected by the loss of nutrients through agricultural activities. In eastern Africa alone, an average of 22 kg N and 2.5 kg P per ha each year have been

lost in the last 30 years (Sanchez 2002). The annual nutrient loss is equivalent to \$ 4 billion in fertilizer.

Due to many factors including unattainable higher costs, inorganic fertilizer consumption in the SSA countries is low, and continues to decline. In 1996, Gruhn *et al.* (2000) reported that SSA consumed on average only 8.9 kg of fertilizer per ha of arable land, compared to 97.7 kg globally. Partially as a consequence, per capita food production in SSA has been declining since the early 1990s (de Jager 1998). Furthermore, experience has shown that use of inorganic fertilizers alone is insufficient to maximize crop yields,

for such fertilizers provide only some nutrients, while a range of other nutrients required are still mined from inadequate progressively small soil reserves. Sanchez (1994) proposed that crop production should rely more on biological processes by adapting germplasm to diverse soil conditions, enhancing soil biological activity and optimizing nutrient cycling to minimize external inputs and maximize the efficiency of their use. In this context, many options including use of cover crops and improved fallows as sources of green manures combined with minimal external inputs have been tested. The combinations allow positive residual soil N and P contribution to the successive crops. Economic analysis of these systems demonstrated an increase of 50–70% in gross incomes of adapting farmers compared to those still following continuous maize cultivation. Furthermore, increases in legume areas of 10% in Nigeria and increases of 20% in yield have translated into additional fixed N valued at \$44 million annually (Sanginga *et al.* 2003).

However, combating the problem of declining soil fertility requires thorough testing of promising technology proved potential elsewhere. In this view, a field experiment was conducted to assess the effects of natural and *T. vogelii* fallows treated with Minjingu phosphate rock (MPR) at establishment on subsequent total inorganic N, Pi-P and maize grain yield in acidic, N and P deficient Ferralsol.

Materials and methods

The experiment was conducted in the Sokoine University of agriculture (SUA) Farm, (37°39'12.4"E, 06°50'24.5"S), in eastern Tanzania, at an elevation of 540 m a.s.l. The soil was classified using FAO Soil Classification (FAO 2001) and the USDA Soil Taxonomy (Soil Survey Staff 1999) systems as Hyperdystric Umbric Ferralsol and Typic Haplustox, respectively. The soil was clay (54% clay), acidic (pH-H₂O-5.1), low

P (Bray-1 P-2.1 mg kg⁻¹) and deficient in N (0.07%). The climate is sub-humid tropical with bimodal rainfall distribution.

Following land preparation by farm tractor, the experiment was laid as RCBD, replicated three times with plot size of 4 x 8 m. Three fallow systems namely natural, P unfertilised and P fertilized *T. vogelii* fallows at planting were established. In order to improve tilth in the subsoil, holes measuring 20 x 20 cm and a depth of 30 cm at a spacing of 50 x 50 cm, were dug and then back filled starting with top soil. In plots amended with MPR, the soil from each hole was thoroughly mixed with MPR and then back filled. Four seeds of *T. vogelii* were direct seeded at the centre of the back filled holes at 1–2 cm depth and grown for 22 months.

At 22-months, *T. vogelii* plants were uprooted and leaves separated from stems, followed by land preparation. Residues from natural fallow were incorporated in the soil during land preparation. The incorporated *T. vogelii* biomass consisted mainly of litter. The fertilizer combinations were randomly allocated on plots that were previously under three fallows (Table 1)

Tephrosia vogelii biomass, MPR and TSP were broadcast and incorporated to about 15-cm depth and maize (var. TMV-1) planted at 30 x 75 cm spacing. Sulphate of ammonia was applied in two equal halves, at two and four weeks after maize planting. Recommended agronomic practices such as timely weeding and pest control were strictly adhered to. At maturity maize cobs were harvested on a net plot of 3.4 x 6.5 m, sun dried and shelled.

The data collected include total inorganic-N concentrations, Pi-P values, and maize grain yield. Total inorganic-N concentrations in all the treatments were monitored during the growing season through analysis of surface (0–15 cm depth) soils samples on 4 March 2002 (at planting), on 6 April 2002 (at 35 days after planting) and on 16 April 2002 (45 days after planting). The Pi-P values in all the treatments were determined during the growing season through analysis of soil

Table 1. Fertilizer combinations tested in the first post-fallow maize

Previous fallow system	Fertilizer treatments for evaluating maize response
1. Natural fallow	Control
2. Natural fallow	0 kg P+80 kg N ha ⁻¹ (SA)
3. Natural fallow	80 kg P+80 kg N ha ⁻¹ (TSP+SA)
4. Natural fallow	80 kg P+80 kg N ha ⁻¹ (MPR+SA)
5. 0 kg P ha ⁻¹ <i>T. vogelii</i> fallow	0 kg P+80 kg N ha ⁻¹ (<i>T. vogelii</i> biomass alone)
6. 80 kg P ha ⁻¹ <i>T. vogelii</i> fallow	80 kg P+80 kg N ha ⁻¹ (MPR at planting+ <i>T. vogelii</i> biomass)
7. 0 kg P ha ⁻¹ <i>T. vogelii</i> fallow	80 kg P+80 kg N ha ⁻¹ (MPR+ <i>T. vogelii</i> biomass)

samples taken on 16 April 2002 (45 days after maize planting). Maize grain yield was determined at 12.5% moisture and calculated on per ha basis.

Standard laboratory procedures as described by Okalebo *et al.* (2002) were used to analyse soil and plant samples. The data were analysed by MSTAT-C statistical package and significant means were separated using Duncan's New Multiple Range Test or student t-test at 5% level.

Results and discussion

Total inorganic-N concentrations

The results for total inorganic-N concentrations as influenced by applications of fallow biomass and MPR (residual and current) in maize are presented in Fig. 1. At planting (4 March 2002), total inorganic-N concentrations were significantly affected by MPR and *T. vogelii* fallow biomass applications. The total inorganic-N concentrations were significantly higher in plots that were under *T. vogelii* fallows and applied

with its biomass than in other treatments. Application of MPR at fallow establishment or co-applied with *T. vogelii* biomass significantly reduced total inorganic-N concentrations. The total inorganic-N concentrations in *T. vogelii* fallow plots that were amended with MPR at fallow establishment ranged from 10.8–11.8 mg kg⁻¹. Application of NF biomass led to significantly lower total inorganic-N concentrations than in the treatments applied with *T. vogelii* fallow biomass.

At 35- and 45-days after planting (6 and 26 April 2002), total inorganic-N concentrations in plots treated with *T. vogelii* fallow biomass were significantly higher than in plots treated with NF biomass. Application of S/A alone significantly increased total inorganic-N concentrations on both 6 and 16 April 2002. Co-application of MPR with either S/A or *T. vogelii* biomass or TSP with S/A led to significant depression of total inorganic-N concentrations throughout the three sampling dates. This suggested that P availability and uptake by maize caused higher N uptake. In a field experiment conducted in semi-arid zone of eastern Kenya using sorghum as a test crop, Warren *et al.* (1997) reported that P application depressed

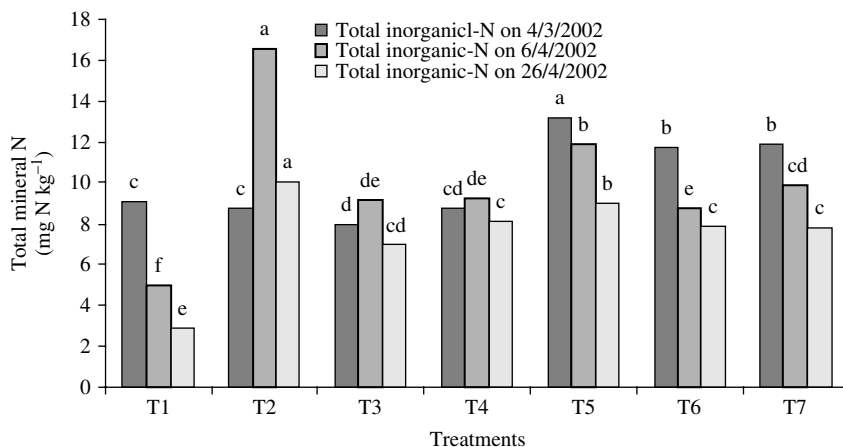

Figure 1. Influence of co-application of MPR and *T. vogelii* fallow biomass on total mineral N.

Legend:

- T1 Natural fallow biomass applied at maize planting (2001/02).
- T2 S/A (80 kg N ha⁻¹) applied at maize planting (2001/02, 2002/03).
- T3 TSP (80 kg P ha⁻¹)+S/A (80 kg N ha⁻¹) applied at maize planting (2001/02).
- T4 MPR (80 kg P ha⁻¹)+S/A (80 kg N ha⁻¹) applied at maize planting (2001/02).
- T5 *T. vogelii* biomass (80 kg N ha⁻¹) applied at maize planting (2001/02).
- T6 *T. vogelii* biomass (80 kg N ha⁻¹)+MPR applied at *T. vogelii* fallow establishment (1999/00).
- T7 *T. vogelii* biomass+MPR co-applied at maize planting (2001/02).

NO₃-N concentrations due to increased plant uptake of these nutrients. The total inorganic-N concentrations in all the treatments were generally higher at the beginning of the rainy season, decreased as rainy season progressed and were lowest towards the end of the season.

Higher total inorganic-N concentrations on 4 March 2002 (6 days after incorporation of biomass) were preceded by a heavy rainstorm on 2 March 2002 could be associated with initial rapid decomposition and N release of the fallow biomass. Gradual decrease in total inorganic-N concentrations with increase in time from planting (2 March 2002) could be caused by increased maize N uptake and leaching losses. In a field experiment, involving *T. vogelii* biomass, sorghum residues and NF biomass in South Rwanda, Hagedorn *et al.* (1997) observed that an N flush occurred during the first 5 days of the rainy season that doubled the mineral N concentrations. Leaching of total inorganic-N from *T. vogelii* biomass and sorghum residues was highly related ($r^2 = 0.94$) to mineralized N at the beginning of the rainy season (Hagedorn *et al.* 1997). Prescott (1997) reported that soil moisture is a more critical factor for mineralization than temperature. The rate of N release from *Gliricidia sepium*

and *Leucaena leucocephala* pruning was reduced by inadequate moisture (Handayanto *et al.* 1994).

In all the three sampling dates, total inorganic-N concentrations in plots treated with *T. vogelii* biomass alone or co-applied with MPR were consistently higher than in plots treated with NF biomass. This was probably caused by slow rate of N release and high N concentrations of the decomposing residues of *T. vogelii* biomass. The pronounced effect of *T. vogelii* leaves on higher total inorganic-N throughout the rainy season relative to NF was also reported by Hagedorn *et al.* (1997) in Rwanda.

Pi-P in the first post-fallow maize

The effect of MPR application at establishment of *T. vogelii* fallow or MPR co-applied with *T. vogelii* biomass at maize planting on Pi-P at 45 days after maize planting (16 April 2002) is presented in Fig. 2. The Pi-P values were significantly affected by the two MPR application strategies. Application of MPR at *T. vogelii* fallow establishment followed by fallow biomass application (T6) led to slight increase in Pi-P values relative to co-application of MPR with fallow biomass at

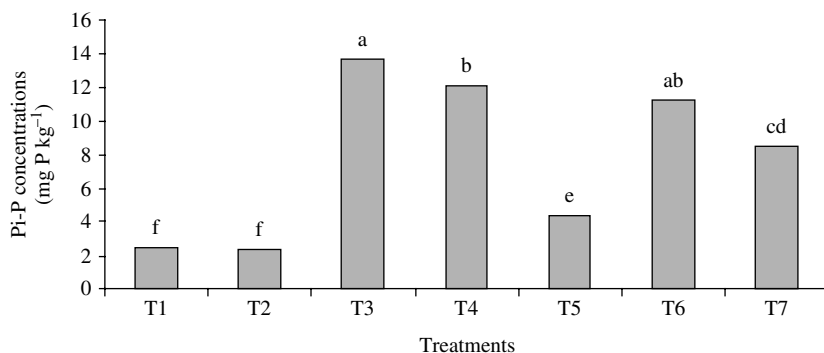

Figure 2. Influence of co-application of *T. vogelii* biomass and MPR on Pi-P concentrations.

Legend:

- T1 Natural fallow biomass applied at maize planting (2001/02).
- T2 S/A (80 kg N ha⁻¹) applied at maize planting (2001/02, 2002/03).
- T3 TSP (80 kg P ha⁻¹)+S/A (80 kg N ha⁻¹) applied at maize planting (2001/02).
- T4 MPR (80 kg P ha⁻¹)+S/A (80 kg N ha⁻¹) applied at maize planting (2001/02).
- T5 *T. vogelii* biomass (80 kg N ha⁻¹) applied at maize planting (2001/02).
- T6 *T. vogelii* biomass (80 kg N ha⁻¹)+MPR applied at *T. vogelii* fallow establishment (1999/00).
- T7 *T. vogelii* biomass+MPR co-applied at maize planting (2001/02).

maize planting (T7). The Pi-P values were significantly increased by application of *T. vogelii* biomass alone (T5) compared to NF biomass (T1). Application of TSP+S/A (T3) gave significantly higher Pi-P values than that of MPR+S/A (T4). The treatment which received MPR at fallow establishment and *T. vogelii* biomass at planting in 2001/02 (T6) had Pi-P values comparable to that in MPR+S/A treatment. Application of MPR+S/A (T4) led to slightly higher Pi-P values than that of MPR+*T. vogelii* biomass (T7).

Increased Pi-P values by MPR application at fallow establishment could be caused by both soil and plant related factors. In the case of soil related factors, the soil of the site was strongly acidic and inherently low in P (Table 3). Strong soil acidity and low P levels favour MPR dissolution (Mnkeni *et al.* 1991). Enhancement of Pi-P concentration in plots amended with MPR at fallow establishment could also be due to Ca and P uptake by *T. vogelii* and maize plants. Increased Ca and P uptake by these plants could have caused greater MPR dissolution. Application of MPR at fallow establishment led to 3-fold increase in total P accumulated by *T. vogelii* plants relative to the control.

The Pi-P values in plots that were treated with MPR at establishment of *T. vogelii* fallow then followed by application of fallow biomass were significantly higher than that in NF. Higher Pi-P values in plots that were

Table 2. Initial soil properties of experimental site

Horizon	A _p	AB
Depth (cm)	0–20/30	20/30–39/53
Clay (%)	57.2	63.2
Silt (%)	10.8	8.8
Sand (%)	32	28
Texture class	C	C
pH-H ₂ O (1:2.5)	4.8	4.7
pH-KCl (1:2.5)	4.2	3.7
Organic C (%)	1.02	0.73
Total N (%)	0.12	0.04
C/N	8.5	18.25
Available P Bray-I (mg kg ⁻¹)	1.43	0.97
Available Pi-P (mg kg ⁻¹)	1.2	0.72
CEC NH ₄ OAc (cmol(+) kg ⁻¹)	9.3	8.3
Exch. Ca (cmol(+) kg ⁻¹)	2.44	1.64
Exch. Mg (cmol(+) kg ⁻¹)	1.62	0.98
Exch. K (cmol(+) kg ⁻¹)	0.27	0.13
Exch. Na (cmol(+) kg ⁻¹)	0.16	0.10
TEB (cmol(+) kg ⁻¹)	4.49	2.85
Base saturation (%)	48.28	34.34
CEC clay (cmol(+) kg ⁻¹)	10.11	9.15

treated with MPR at fallow establishment was caused by increased Pi-P values during the fallow period and P released from decomposing *T. vogelii* biomass. The Pi-P data suggest that application of MPR at fallow establishment is a better strategy than co-application of MPR with *T. vogelii* biomass at maize planting.

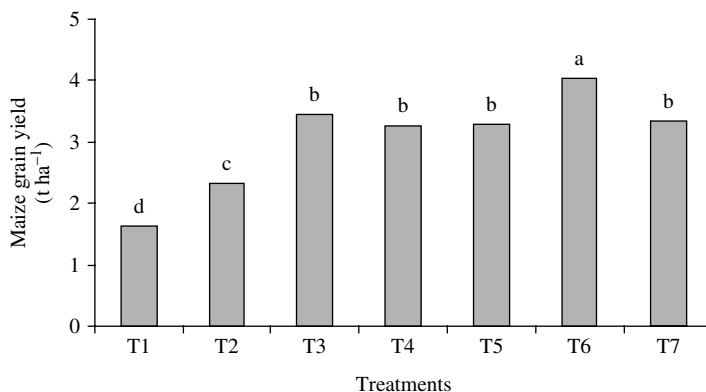

Figure 3. Effect of co-application of *T.vogelii* biomass and MPR on maize grain yield.

Legend:

- T1 Natural fallow biomass applied at maize planting (2001/02).
- T2 S/A (80 kg N ha⁻¹) applied at maize planting (2001/02, 2002/03).
- T3 TSP (80 kg P ha⁻¹)+S/A (80 kg N ha⁻¹) applied at maize planting (2001/02).
- T4 MPR (80 kg P ha⁻¹)+S/A (80 kg N ha⁻¹) applied at maize planting (2001/02).
- T5 *T. vogelii* biomass (80 kg N ha⁻¹) applied at maize planting (2001/02).
- T6 *T. vogelii* biomass (80 kg N ha⁻¹)+MPR applied at *T. vogelii* fallow establishment (1999/00).
- T7 *T. vogelii* biomass+MPR co-applied at maize planting (2001/02).

Maize grain yield

The first post fallow maize grain yields as influenced by application of MPR, and biomass from natural or *T. vogelii* fallows are given in Fig. 3. Application of different fertilizer materials significantly increased maize grain yield. The highest maize grain yield was obtained from treatments in which MPR was applied at *T. vogelii* fallow establishment and later treated with *T. vogelii* biomass. Application of *T. vogelii* biomass alone or co-application with MPR, MPR+S/A and TSP+S/A gave similar but significantly lower maize grain yield than in soils treated with MPR at fallow establishment. Relative to NF plots, maize yield was increased by 147% (4.05 t ha⁻¹) in plots treated with *T. vogelii* biomass that were amended with MPR at fallow establishment, by 105% (3.35 t ha⁻¹) in plots where *T. vogelii* biomass was co-applied with MPR, and by 100% (3.28 t ha⁻¹) in plots applied with *T. vogelii* biomass alone. Compared to application of S/A alone which led to maize grain yields of 2.35 t ha⁻¹, the yields from plots treated with *T. vogelii* biomass alone was 3.28 t ha⁻¹ which is equivalent to an increase of 39.6%.

Improvement of maize grain yield subsequent to *T. vogelii* fallows has been reported by many workers (Drechsel *et al.* 1996; Gichuru 1991; Niang *et al.* 1996). They also found that the duration of *T. vogelii* fallows affected subsequent grain yield. Relative to natural fallow, maize grain yield planted after *T. vogelii* fallows of 2 years was >150% (Gichuru 1991), while the yield obtained after 1-year fallow ranged between 70 and 100% (Drechsel *et al.* 1996) and that after 6-months fallow was 33% (Niang *et al.* 1996).

Application of either TSP+S/A, MPR+S/A or *T. vogelii* biomass alone gave similar maize grain yields. This indicates that MPR+S/A application on soils with favourable conditions could be as effective as TSP. Significant increase in maize grain yield by application of *T. vogelii* biomass alone could be caused by consistently higher total inorganic-N during the season (Fig. 1), improved Pi-P (Fig. 2), and associated favourable soil conditions such as pH and exchangeable Ca caused *T. vogelii* biomass and MPR applications. Application of S/A alone resulted in significantly lower maize grain yield (2.35 t ha⁻¹) than treatments which received both N and P from either sources (3.27–4.05 t ha⁻¹), suggesting that S/A alone cannot optimize yield in P deficient Ferralsols.

Table 3. First post fallow maize response to fallow biomass and MPR applications

Treatments	Maize grain yield (t ha ⁻¹)	RAE ³ (%)
1. Natural fallow	1.64d	
2. S/A	2.35c	39.2
3. TSP + S/A	3.45b	100
4. MPR + S/A	3.27b	90.1
5. <i>T. vogelii</i> biomass	3.28b	90.6
6. <i>T. vogelii</i> biomass+MPR ¹	4.05a	133.1
7. <i>T. vogelii</i> biomass+MPR ²	3.36b	95.0
CV (%)	13.5	

Means and bearing the same letter within a column are similar using DMRT at P≤0.05;

¹ MPR applied on *T. vogelii* fallow at establishment in 1999/00 season;

² MPR co-applied with *T. vogelii* biomass at maize planting in 2001/02 season;

³ AE (%) = $\frac{\text{Yield}_{\text{treatment}} - \text{Yield}_{\text{control}}}{\text{Yield}_{\text{TSP}} - \text{Yield}_{\text{control}}} \times 100$.

Relative agronomic effectiveness of different P sources

Relative agronomic effectiveness of different P sources is given in Table 3. Application of *T. vogelii* biomass alone led to an added maize grain yield of 0.5% compared to addition of MPR+S/A. Co-applying *T. vogelii* biomass and MPR led to 4.9% increase in grain yield relative to MPR+S/A application. Application of MPR at establishment of *T. vogelii* fallow and then treated with *T. vogelii* biomass had RAE values of 130% with and 133.1% without-*T. vogelii* relay. This is equivalent to an increase of about 30% compared to that of standard fertilizer recommendation of TSP+S/A. Under these soil conditions, MPR was 90% effective compared to TSP. A similar response pattern of maize to MPR and TSP applications has been reported elsewhere. In acid soils of western Kenya, Mutuo *et al.* (1999) reported that MPR produced maize yield increases relative to TSP ranging from 80 to >100%.

These observations indicate that inadequate P levels in these soils severely limit maize yields, and that application of *in situ T. vogelii* biomass alone or with MPR could substantially improve maize grain yield, but is more beneficial when MPR is applied to *T. vogelii* fallow at establishment.

Conclusions

On the basis of the data generated in this study, the following conclusions were made: 1) Co-application

of MPR with *T. vogelii* biomass depressed Pi-P while application of MPR alone increased it, 2) Application of *T. vogelii* biomass improved more total inorganic-N and Pi-P concentrations than natural fallow biomass throughout the rainy season, and, 3) Application of MPR at *T. vogelii* fallow establishment followed by incorporation of fallow biomass increased more maize grain yield than co-application of MPR and *T. vogelii* fallow biomass at the same time. Application of *T. vogelii* fallow biomass alone increased more maize grain yield than NF biomass.

Acknowledgements

The authors would like to thank the financial support provided by Tanzania Agricultural Research Project, African Academy of Sciences and African Network (AfNet) of Tropical Soil Biology and Fertility (TSBF) an Institute of CIAT that enabled us conduct this work. We also sincerely appreciate financial support of AfNet, which enabled us to present these findings in this Conference.

References

- de Jager A., Karuiku I., Matiri F.M., Odendo M. and Wanyama J.H. 1998. Monitoring nutrient flows and economic performance in African farming systems (NUTMON). IV. Linking nutrient balances and economic performance in three districts of Kenya. *Agriculture, Ecosystems, and Environment* 71: 81–92.
- Drechsel P., Steiner K.G. and Hagedorn F. 1996. A review on the potential of improved fallows and green manure in Rwanda. *Agroforestry Systems* 33: 109–136.
- Eswaran H., Almaraz R., van den Berg E. and Reich P. 1997. An assessment of the soil resources of Africa in relation to productivity. *Geoderma* 77: 1–18.
- FAO 2001. Lecture notes on the major soils of the world. *World Soil Resources Reports* No. 94. ISRIC, ITC, CUL, WAU, FAO, Rome, Italy. pp. 155–161.
- Gichuru M.P. 1991. Residual effects of natural bush, *Cajanus cajan* and *Tephrosia candida* on the productivity of an acid soil in south-eastern Nigeria. *Plant and Soil* 134: 31–36.
- Gruhn P., Goletti F. and Yudelman M. 2000. Integrated Nutrient Management, Soil Fertility and Sustainable Agriculture: Current Issues and Future Challenges.
- Hagedorn F., Steiner K.G., Sekayange L. and Zech W. 1997. Effect of rainfall pattern on N mineralization and leaching in a greenhouse experiment in Rwanda. *Plant and Soil* 195: 365–375.
- Handayanto E., Cadisch G. and Giller K.E. 1994. Nitrogen release from prunings of legume hedgerow trees in relation to quality of the prunings and incubation method. *Plant and Soil* 160: 237–248.
- Mnkeni P.N.S., Semoka J.M.R. and Buganga J.B.B. 1991. Effectiveness of Minjingu Phosphate rock as a source of phosphorous for maize in some soils at Morogoro, Tanzania. *Zimbabwe Journal of Agricultural Research* 29: 27–37.
- Mutuo P.K., Smithson P.C., Buresh R.J. and Okalebo R.J. 1999. Comparison of Phosphate rock and Triple Superphosphate on a Phosphorus-Deficient Kenyan Soil. *Communications in Soil Science and Plant Analysis* 30: 1091–1103.
- Niang A., Gathumbi S. and Amadalo B. 1996. The potential of short-duration improved fallow for crop productivity enhancement in the highlands of Western Kenya. In: *Proceedings of the 1st Kenya National Agroforestry Conference on People and Institutional Participation in Agroforestry for sustainable development*. (Edited by Mugah, J.O.). 3–8 May 1996, Nairobi Kenya. pp. 218–230.
- Okalebo J.R., Gathua K.W. and Woomer P.L. 2002. *Laboratory Methods of Soil and Plant Analysis*. A working manual. KARI, SSSEA, TSBF, UNESCO-ROSTA, Nairobi, Kenya. pp. 128.
- Oldeman L.R., Hakkeling R.T.A. and Sombroek W.G. 1992. World map status of human-induced soil degradation: an explanatory note, International Soil Reference Center, Wageningen. pp. 34.
- Prescott, C.E. (1997). Effect of clear cutting and alternative silviculture systems on rates of decomposition and nitrogen mineralization in a costal montane coniferous forest. *Forest Ecology and Management* 95: 253–260.
- Sanchez P.A. 1994. Tropical soil fertility research: Toward the second paradigm. Inaugural and State of the Art Conferences. *Transactions 15th World Congress of Soil Science*. 10–16 July 1994, Acapulco, Mexico. pp. 65–88.
- Sanchez P.A. 2002. Soil Fertility and Hunger. *Science* 295: 2019–2020
- Sanginga N., Dashiell K., Diels J., Vanlauwe O., Lyasse O., Carsky R.J., Tarawali S., Asafo-Adjei B., Menkir A., Schulz S., Keatinge D. and Rodomiro O. 2003. Sustainable management coupled to resilient germplasm to provide new intensive cereal-grain legume-livestock systems in the savanna. *Agriculture, Ecosystems and Environment*, *In press*.
- Soil Survey Staff 1999. Keys to Soil Taxonomy. Agency for International Development, United States Department of Agriculture and Natural Resources Conservation Service, Blacksburg, Virginia, USA. pp. 328.
- Warren G.P., Atwal S.S. and Irungu J.W. 1997. Soil nitrate variations under grass, sorghum and bare fallow in semi-arid Kenya. *Exploratory Agriculture* 33: 321–333.

Environmental hazards in African agriculture: factors influencing application of agrochemicals in Nakuru district, Kenya

Lagat J.K.*, Wangia S.M., Njehia B.K. and Ithini G.K.

*Department of Agricultural Economics, Egerton University, P.O. Box 536, Njoro, Kenya, Email: jlagats@yahoo.com, Tel: 254-0722-392268, Fax: 254-051-62527

Abstract

This paper uses data from a 2003 survey of farming households in Nakuru, Kenya. The objectives were: to establish the quantities of agrochemicals applied as compared to recommendations thus detecting under use or over dose and to explore the factors influencing the applications of agrochemicals to see how far those factors can be manipulated to contribute to better implementation of integrated pest management (IPM) and integrated plant nutrition systems (IPNS). Both descriptive statistics and a decomposed tobit model were used. Two separate models for fertilizer and fungicides were estimated. Results indicate that a greater elasticity of application of fertilizer would be generated more by expected levels of application and less by marginal changes in the amounts applied. The greater influence to apply would come from those expected to gain any experience in tomato production and less from unit changes in length of experience. For the fungicides model, the person who makes the decision has a strong influence in the increase of application of fungicides. Implications for policy are drawn

Key words: agrochemicals, environment, hazards, pollution, tomato production, Tobit

Introduction

Agro-chemical consumption has increased rapidly in the last 45 years, in sub-Saharan Africa. For instance, nitrogen consumption has risen from 2 to 75 million tonnes per annum and pesticide consumption has risen by 10–30% (Nkamleu and Adesina 2000). The developed countries that have long experiences in agro-chemical applications have increasingly raised concerns regarding the detrimental effect which modern farming practices are thought to have on the countryside (Garrod and Willis 1995). Already, the developing countries are experiencing the hazards of agrochemicals because of large populations exposed, the greater institutional barriers, educational barriers to safe use, and higher rates of inter-farm spillovers stemming from smaller farm patterns prevalent in developing countries. The problems of pollution and contamination in developing countries could reach or exceed those of developed countries (Anonymous 1987).

Agricultural run-off carries a range of pollutants into rivers, streams, and lakes. It includes such residuals as sediment, bacteria, pesticides and fertilisers (Shortle and Dunn 1991). Recent studies in Nakuru district indicate that fungicides are heavily applied in tomato production and excessive exposure to some of these chemicals is of great concern (WWF 2000). Moreover, tomato is consumed as a fresh vegetable in most households, which increase the vulnerability to residuals. Current research trends show the development towards integrated pest management (IPM) and integrated plant nutrition systems (IPNS). IPM is a systems approach to reduce pest damage to tolerable levels using biological control, cultural control genetically resistant varieties, and when appropriate, chemical pesticides especially those that are selective and do not contribute to environmental contamination and health problems. The use of organic manure and crop residues as mulching material could contribute greatly to nutrient and structural stability of the soil

influencing porosity and water infiltration. Long term investment in IPM could be effective in restoring soil fertility to levels where intensive agriculture can be sustained.

Nakuru district has a good agricultural potential that allows growing of most food crops. Households in zones where ecological conditions are suitable grow tomato as a high value enterprise. The ecological and input requirements for tomatoes are similar under smallholder agriculture in the country, thus making Nakuru a good representation. The objectives of the study were twofold: first, to establish the quantities of agrochemicals applied as compared to recommendations thus detecting under use or over dose; second, to explore the factors influencing the applications of agrochemicals to see how far those factors can be manipulated to contribute to better implementation of IPM and IPNS.

Data setting

The major tomato growing areas in Nakuru district are in the administrative divisions of Bahati and Mbogoini. In each of the divisions, the topography is such that there are upper and lower zones. According to classification by Schmidt and Jaetzold (1983), the upper zone falls under the LH3 (Lower Highland) the lower zone is classified as UM4 (Upper Midland).

In upper Bahati, the average land holding was 0.64 hectares. The main crop planted in the first season (March to August) was maize/beans intercrop. These food crops provide a food security measure in the household. It is important to note that in upper Bahati, tomatoes were planted in only one season in a year and that was in the second part of the year between September and December. The practice was that as the maize matured, farmers pruned the foliage opening the rows to light and then planted tomatoes in between. In contrast, lower Bahati is predominantly a tomato growing area where 76% of the farmers grow tomatoes in both seasons. The average land per household was 2.5 hectares and they practiced intensive tomato growing. The rationality of the farmers is evident in the choice of enterprises that maximize land limitations. The farmers engage in commercial tomato production to satisfy a ready market either in the major urban centres such as Nakuru and Nyahururu or in a tomato canning factory that is strategically located in the growing area at Kabazi.

The data was collected by use of structured questionnaires. Because of homogeneity in the production methods of tomatoes among the farmers, 100 respondents were sampled at random in May–June 2003.

Quantities of agrochemicals used by farmers

The quantities of fertilizers and fungicides applied in tomato production are given in Table 1.

The mean applied quantities provide important information on the current contamination status of a key tomato producing area in Nakuru district and point to the need for urgent action to minimize the excessive use of agrochemicals. There was a wide range of agro-chemicals available to the farmers from various sources. It was revealed that 17 identifiable agrochemicals were frequently used in tomato production (Table 1). The major agro-chemicals applied were fertilizers, fungicides, insecticides, and foliar feed. The fertilizers used were phosphate fertilizers applied during planting notably, di-ammonium phosphate (DAP) and compound fertilizers (NPK). Nitrogen fertilizers were applied during plant growth especially to help in fruit formation and development. Those commonly used sources of nitrogen were UREA and calcium ammonium nitrate (CAN). It is noted that only 50% of N is taken up by crops and the remainder is leached or probably incorporated in soil organic matter.

Fungicides are applied variously in all stages of plant growth to protect tomatoes from fungal attacks such as early and late blights. The commonly used fungicides were in the following trade names: sancozeb, green copper, milraz, antracol, ridomil, dithane, acrobat, pencozeb, daconil, fastac, and wetsulf. The main insecticides used were polytrine, karate and dimethoate. Foliar feed was strategically applied to the plants at flowering stage to boost fruit formation.

The recommended rate for application of phosphate is 200 kilograms per hectare. However, farmers applied 206 kilograms per hectare. The rates applied were within the recommendation. The total amount of nitrogen applied was 174 kilograms per hectare (kg ha^{-1}) while the recommended rate is 150 kg ha^{-1} indicating excess application. This is surprising in a continent known for less use of fertilizers (Strasberg 1999; Okigbo 1990; Woomer and Muchena 1993). However, horticultural production in Kenya is generally known to use fertilizers (Mose, 1999). It is noted that only 50% of N is taken up by crops and the remainder is leached or probably incorporated in soil organic matter.

Table 1. Types, total quantities and rates of agrochemicals applied on tomatoes in Nakuru district

Chemical type	Quantity applied (kg)	Mean	SD	Percent users	Kilograms applied per hectare (kg/ha)	Manufacturers' recommendation per hectare
Phosphate	9823	98.23	132.14	81	206	200
Nitrogen	8312	83.12	111.91	88	174	150
Sancozeb	496	4.96	12.62	30	10.4	1.5–2.5
Copper	503	5.03	14.31	40	10.5	2.0–3.0
Milraz	501	5.01	10.22	61	10.5	2.0
Antracol	46.1	0.46	1.598	12	1.0	2.0–2.5
Ridomil	313	3.13	11.10	18	6.6	2.5
Dithane	47	0.47	1.56	10	1.0	2.0
Acrobat	19	0.19	1.01	4	0.4	1.5
Pencozeb	62	0.64	2.55	9	1.3	1.5–2.5
Daconil	20	0.20	2.00	1	0.42	1.7–2.0
Wetsulf	22	0.219	1.08	8	0.5	1.5–2.0
Fastac*	12	0.12	0.57	6	0.25	0.5
Foliar feed*	157	1.57	4.76	31	3.3	2.5
Dimethoate*	25	0.25	1.30	7	0.5	1.5–2.0
Polytrine*	248	2.48	10.75	44	5.2	1.5
Karate*	21	0.22	0.64	13	0.4	1.0

Source: author's compilation, *Quantities in Litres.

Although quite a lot still needs to be learnt about the side effects of chemical pesticide use in Kenya, there may be potential and actual social and economic costs from excessive pesticides use. Such costs make it desirable to reduce the use of chemical pesticides without reducing the needed protection. Four different fungicides were used in heavy volumes namely; sancozeb, copper, milraz, and ridomil. In terms of popularity, milraz was used by 61% of respondents. The other important ones were copper (40%) and sancozeb (30%). The least popular was daconil (1%). The others (Table 1) ranged in use between 4–18%. It is assumed that from experience, farmers have known the more efficient chemicals for their purposes and systematically phased out the less efficient ones.

Farmers practiced crop protection by applying fungicides. For comparison, the recommended application rates were obtained from manufacturers' product labels. The total amounts of fungicides sprayed on tomatoes in large quantities were: sancozeb, was applied at 10.4 kg ha⁻¹ compared to recommended rate of 1.5–2.5 kg ha⁻¹. The amount of copper applied was 10.5 kg ha⁻¹ compared to the manufacturer's recommended rate of 1.5–2.5 kg ha⁻¹. Milraz, was applied at 10.5 kg ha⁻¹ compared to the recommended rate of 2.0 kg ha⁻¹. Ridomil was applied at 6.6 kg ha⁻¹ compared to a standard of 2.5 kg ha⁻¹. It is apparent that farmers apply extremely high rates as compared to

recommendations. On overall, these rates range from 3–7 times the recommended ones reflecting the intensity of emission to the environment. Only pencozeb and foliar feed were applied correctly. The rest of the fungicides (dithane, acrobat, daconil, fastac, wetsulf and dimethoate) were applied at lower than half the recommended rates. The cumulative emission by fungicides was 2041.3 kg. A total of 157 litres of foliar feed was applied at the rate of 3.3 kg ha⁻¹ compared to the recommended 2.0 kg ha⁻¹. The rates for polytrine, an insecticide were 5.2 litre ha⁻¹ rather than 1.5–2.0 litre ha⁻¹.

These results point out to two major issues. First, due to land limitation, farmers were practicing intensive farming and tomato production was considered a high value enterprise. There is a marked bias towards chemical crop protection whereas crop management often involves alternative methods such as cultural and biological control whose awareness is almost none. Second, although farmers claim to understand use of agrochemicals, the results indicate otherwise. Their knowledge may be limited to only safe use and not other aspects such as application rates. Apart from increasing pollution, the excess application is an unnecessary cost.

The major challenge is how to reduce crop losses while minimizing pest resistance to pesticides and harmful side effects to human health and environment. However given the prevailing conditions in

developing countries (illiteracy and ignorance of side effects) the safe and proper use of chemical plant products cannot be guaranteed (Atkin and Leisinger 2000).

The conceptual model

This study adopts a Tobit model to analyse the factors that determinant the use of fertilizers and fungicides by tomato farmers. This is because the tobit model uses all observations, both those at the limit and those above it to estimate regressions, and is preferred over alternative discrete choice models (McDonald and Moffit 1980). In this study, actual quantities of fertilizer and fungicides were used as the dependent variables. Because the dependent variable is censored at zero, the model is identified within a tobit framework and maximum likelihood estimator is used in estimation (Kmenta 1986). Discrete choice models have been applied widely in analysis of socio-economic factors in agricultural activities. Studies on adoption have addressed various technologies including crop varieties (Chandel and Chakor 1998; Kimenye 2001), agricultural chemicals like fertilizers (Nkamleu and Adesina 2000; Nkonya et al. 1997; Karanja et al. 1999), land conservation (Shiferaw and Holden, 1998) and water conservation (Baidu 1999). One of the weaknesses of discrete choice models is a possible loss of information if a binary variable is used as a dependent variable (Lynne et al. 1988). Initially, a bivariate tobit model was to be used with nitrogen and fungicide as the dependent variables. However, because of high correlation between the two inputs, two independent tobit equations were estimated. Therefore, the dependent variables were nitrogen (NITRO) and fungicide (FUN). The biggest advantage of the tobit model is that it sufficiently estimates the probability and intensity of application of the two inputs.

Once exposed to a technology like agrochemicals, a farmer may or may not adopt. Even where it has been adopted, it is applied at different levels. Such a scenario is explained by underlying utility derived from use or non use of the agrochemicals. The perceived utility from the application of fertilizer and fungicide is represented by $U(a)$ and the utility from non application is $U(0)$. The set of socio-economic and institutional factors which influence the decision to apply fertilizers and fungicide by the i^{th} farmer is X_i . Following Greene (2000) and McDonald and Moffit (1980), the

Tobit model is given as an index function such that

$a_i = \beta X_i + \varepsilon_i$ is unobserved latent variable observed only when positive

$a_i = 0$ if $\beta X_i + \varepsilon_i \leq 0$ for non application

$a_i = a_i^*$ if $\beta X_i + \varepsilon_i > 0$ where there is an application

where a_i are the dependent variables representing the amounts of nitrogen and fungicide

X_i is a vector of independent variables such as education, age, season, and others.

β is a vector of unknown coefficients to be estimated ε is an independently distributed error term assumed to be normal with zero mean and constant variance σ^2 . The model assumes that $(\beta X_i + \varepsilon_i)$ which is observed only when it is positive, and hence qualifies as an unobserved, latent variable.

The expected value of a in the model is

$$E_a = \beta X F(z) + \sigma f(z)$$

where $z = \beta X / \sigma$, $f(z)$ is the unit normal density, s is the variance and $F(z)$ is the normal cumulative frequency function. The expected value of a , for observations above the limit, a^* is

$$E_{a^*} = X\beta + \sigma f(z) / F(z)$$

To capture the effect of the change in the i^{th} variable on the dependent variable, a decomposition can be done as follows:

$$\delta E_a / \delta X_i = F(z) (\delta E_{a^*} / \delta X_i) + E_{a^*} (\delta F(z) / \delta X_i)$$

There are two parts: 1) the change in probability of the expected level of application of fertilizer and fungicide for farmers already applying and 2) change in the elasticity of the probability of those already applying (Baidu-Forsen 1999). Each of the terms can be evaluated at some value $X\beta$, usually at the means of the X s. The two partial derivatives can be calculated as

$$(\delta E_{a^*} / \delta X_i) = \beta_i [1 - f(z) / F(z) - f(z)^2 / F(z)^2]$$

$$(\delta F(z) / \delta X_i) = f(z) \beta_i / \sigma$$

Empirical model

The description of variables in the empirical model are given in Table 2. The dependent variables are continuous showing quantities of nitrogen and fungicides in kilograms applied by farmers.

SITE reflects the location of the farmer either in the lower or upper zone. The inclusion of this variable was inspired by the fact that the planting patterns and crop mixes in the two zones differed widely and this was expected to influence their use of fertilizers and pesticides. This is a characteristic that could be peculiar only to the sampled area. It was hypothesized that the variable could assume either sign.

GENDER is a binary variable indexing sex of the household head. Some studies (Doss and Morris 2001 and Karanja et al. (1999) indicate that in some cases, technology adoption decisions do not depend on gender. However, in other studies, gender was significant in influencing adoption (Adesina and Chianu 2002; Nkamleu and Adesina 2000; Burton et al. 1999). The influence of gender on agricultural innovations depends

on the type of technology. In the study area, the application of agricultural chemicals is considered a man's job. It was hypothesized that gender positively influences the application of fertilizers and fungicides.

EDUC is a characteristic of the farmer measuring the number of years of schooling. Education of operators generally influences adoption positively (Stefanides and Tauer 1999; Dev and Hossain 1996). Education increases farmers' access to information and enhances understanding of technical information (Lagat et al. 2003).

HHMEM. The influence of the number of members in a household depends on the type of technology especially where it is expected to be an input. However, since agricultural chemicals are expensive, it has a bearing on household financial outlays. Households must allocate their financial resources efficiently between the inputs and basic family needs. It was hypothesized that HHMEM relates negatively to application of fertilizers and fungicides.

EXPYRS indexes the number of years the farmer has been planting tomatoes. Past findings indicate that with age, farmers accumulate knowledge and wealth

Table 2. Description of explanatory variables and descriptive statistics

Variable	Description	Mean	Min	Max	SD	%
SITE	Location of the farmer. Binary variable. 1 = upper zone, 0 = lower zone	0.480	0.00	1.00	0.502	1=50 0=50
GENDER	Gender of household head. Binary variable 1 = male, 0 = female	0.790	0.00	1.00	0.409	1= 79 0= 21
EDUC	Number of years in school. Continuous variable*	1.941	0.00	2.89	0.729	
HHMEM	Number of members in household	1.838	0.69	2.99	0.443	
EXPYRS	Experience in tomato growing (No of years). Continuous variable*	1.876	0.00	3.21	0.702	
SSNUSE	Season farmers perceived to use more fertilizers and fungicides 1 = March – August, 0 otherwise	0.940	0.00	1.00	0.238	1=94 0=6
DECIDE	Who makes the decisions to apply fertilizers and fungicides? Binary variable. 1 = husband 0 = wife	0.644	0.00	1.00	0.482	1=64 0=36
VAR	Cultivar of tomato planted. Binary variable. 1 = Roma , 0 otherwise	0.410	0.00	1.00	0.494	1=41 0=59
MKTPRI	Market price of tomatoes per crate. Continuous variable*	0.663	4.61	7.60	0.505	
DISTOCK	Distance to stockist in kilometres. Continuous variable*	1.739	0.00	3.68	1.323	
EXTN	Number of contacts with extension agent. Continuous variable*	0.505	0.00	3.00	0.838	

*The values of continuous variables were bigger in magnitude and a log transformation to base e was made to make variation constant across levels. Such conversions are common see for instance work by Omamo, et al., (2002).

and show greater likelihood of investing in innovations. Experience has been found to positively influence adoption (Shiyani et al. 2002; Adesina and Chianu 2002; Amara et al. 1999). Other findings indicate that younger farmers are more likely to adopt new technologies and be early adopters (Alavalapati 1995). However, the experience of farmers in tomato production was hypothesized to positively influence NITRO and FUN. With repeated use over many seasons, the farmers may be able to assess the effectiveness and rates of the different agrochemicals.

SSNUSE is a binary variable measuring the season the farmers perceived to use more agrochemicals. There are usually two planting seasons: the long rains in March to August and the short rains in September to December. Farmers tend to place more emphasis on planting during the long rains due to reduced chances of crop failure. However, they have higher price expectations for the second season crop and this could influence use of chemicals. It was hypothesized that SSNUSE would positively influence the application of fertilizers and fungicides. The season of application is likely to influence the degree of impact of agrochemicals (Shore et al. 1997). Contamination shows a seasonal pattern following the pesticide application (Muller et al. 2002).

DECIDE indicated which of the parents made the decision on the use of chemicals. In smallholder farms, the use of fertilizers and fungicides comprises a major investment decision given other family financial demands. The impact of agricultural technologies depends upon the type of decision making prevailing in the household (Lawrence et al. 1999). With 1 = husband and 0 otherwise, it was postulated that the effect of this variable would be positive.

VAR is a variable indicating the type of tomato cultivar planted. In normal practice, certain cultivars the application of more chemicals than others yet they were preferred by farmers due to their demand by canners or the consumer market. With 1 = Roma variety which required less chemicals and 0 otherwise, it was hypothesized that the variable would positively influence the quantity of chemicals applied.

MKTPRI. The current market price of tomatoes was hypothesized to positively influence the use of fertilizers and fungicides. Better prices would generate higher revenues such that farmers would afford the chemicals more easily. Technology alone cannot sufficiently induce farmers to adopt sustainable production systems. Additional economic incentives are necessary to foster technological change (Kruseman and Bade 1998).

DISTOCK indicates the distance from the farm to the nearest agrochemical stockist. It was hypothesized that distance negatively influenced the use of fertilizers and fungicides. The further the stockist, the less convenient and the more costly in terms of transportation costs (Kohl and Uhl 1986)

The variable EXTN measured the number of times the extension agent was in contact with the farmer over the previous 12 months. Contact with extension services allows farmers to have access to information on use of agrochemicals. Often agricultural extension agents impart different messages throughout the year depending on the prevailing activities. They do incorporate information on the use of agrochemicals during visits to farmer field schools. EXTN was to positively influence the dependent variables.

Results and discussion

A stepwise analysis was done and some variables such as age, market price and farm size were eliminated in the process for the NITRO model and age, farm size, household members in the FUN model.

Six variables were significant in explaining the probability of applying fertilizers in tomato production. These were: the location of the farmer, whether in the upper or lower zone (SITE), the number of years of experience in planting tomatoes (EXPYRS), the season perceived to consume more fertilizer (SSNUSE), the variety of tomato grown (VAR), the distance to the nearest fertilizer (DISTOCK), and the number of contacts with agricultural extension agents (EXTN). The variables those were positive but insignificant were gender, education, number of members in the household, and the person who makes the decision to apply fertilizers.

The location of the farmer was significant at 1%. It positively influences the application of fertilizers in tomato production. The types of crops and planting patterns were totally different in the upper and lower zones. In the upper zones, farmers planted maize/beans in the first season and then tomatoes in the second season. On the lower zone, farmers in the lower zone (especially Wanyororo B) have a tomato monocrop throughout the year. When the decomposition from McDonald and Moffitt (1980) was applied, likelihood of total change in the application of fertilizer due to location of the farmer was 60%. Of this total change, 25% would be generated by marginal changes in the amounts applied by individual farmers, whereas 35% would arise from expected levels of application. The

Table 3. Tobit model results of factors influencing the application of fertilizers in tomato production in Nakuru district, Kenya

Variable	Maximum Likelihood Coefficient	SE	P[Z >z]	Total change ($\delta E_a^*/\delta X_i$)	Change among farmers usage of fertilizers F(z) ($\delta E_a^*/\delta X_i$)	Expected level of use intensity E_a^* ($\delta F(z)/\delta X_i$)
SITE	1.3638	0.2536	0.0001*	0.6042	0.2554	0.3488
GENDER	0.3297	0.3300	0.9204	0.1411	0.0617	0.0794
EDUC	0.9691	0.5275	0.5258	0.4792	0.1870	0.2922
HHMEM	-0.1154	0.2148	-0.5910	-0.0170	-0.0166	-0.0004
EXPYRS	0.2736	0.1581	0.0835**	0.1197	0.0512	0.0685
SSNUSE	1.1629	0.4594	0.0114**	0.5362	0.2178	0.3184
DECIDE	0.3970	0.2788	0.8867	0.1699	0.0743	0.0956
VAR	0.5950	0.2202	0.0068*	0.2548	0.1115	-0.1433
DISTOCK	-3.3213	0.9711	-0.0009*	-0.1412	-0.0602	-0.0810
EXTN	0.3369	0.1296	0.0093*	0.1432	0.0631	0.0801

* significant at 1%, ** significant at 10%.

implication is that with alternative fertilization, targeting those anticipating applying fertilizers might have a greater impact in reducing the use of conventional fertilizers. Although higher yields may only be sustained through judicious use of the correct fertilizers, nutrients can be supplied through the application of organic sources. Greater attention should focus on the use of underutilized farmer organic resources as a means of providing nutrients to the crops and improving the efficiency of fertilizer use (Woomer and Muchena 1995). The use of organic sources of fertilizers needs to be vigorously promoted by the extension agents and NGOs, along with proper methods of preparing high quality farm yard manure.

The longer the farmer has been planting tomatoes (EXP), the higher the chances of using fertilizers. The farmer, through time, experiments different application rates and fertilizer combinations reaching what has been coined as 'farmers' practice'. This variable is significant at 1%. Decomposed results reveal that the anticipated total elasticity in application of fertilizer due to experience in tomato growing is 12%. Out of this, 5% increase in amounts applied would be attributed to unit changes in length of experience. A higher percentage (7%) of increase in application would come from those expected to gain any experience in tomato production. A strategy that would reach farmers still in their formative stage in use of fertilizers would be effective in reducing pollution.

The variable SSNUSE, was included for the season perceived to consume more fertilizers. It was revealed that 94% of the farmers planted their tomato crop in the first season coinciding with the start of the long

rains in March–August. It is at this time that fertilizers are applied in the largest quantities. The coefficient of this variable shows that season of application increases the likelihood of fertilizer application. Thus the impact of agro-chemicals is expected to be more pronounced during the first season. Other authors concur that the presence of fungicides in water is correlated with time of pesticide application. The decomposed results show that the expected total change in fertilizer application resulting from the season of application was 54%. The greater percentage of this change (32%) relates to quantities expected to be applied in the season, while 22% arise from unit changes during the season from those currently applying fertilizers. A strategy that would influence farmers anticipating to apply especially in the period between April and August would reduce the rates of application and would minimize hazards.

The variable of the cultivar planted (VAR) was significant at 1%. There is a positive influence of the cultivar planted on the application of fertilizers. Other varieties apart from Roma cultivar increase the likelihood of using more fertilizers. Varietal nutrient demand suggests that farmers who plant roma variety are likely to save costs by using less fertilizers and therefore less pollution to the soils. The decomposed results reveal that expected total change in fertilizer application resulting from change in the cultivar planted is 25%. Of this, 11% comes from unit change in current applications, whereas 14% would arise from expected levels of application on any variety.

DISTOCK is a variable that captures the distance from the farm to the nearest stockist of agro-chemicals. The variable was significant at 1%. Longer distances

increase the burden and cost of transportation and, therefore, the further a farmer is from a stockist, the greater the likelihood of not purchasing fertilizers. From decomposed results, the total likelihood of change in fertilizer application due to the variety planted is 14%. Out of this, 8% of the anticipated change arises from purchases from stockists located close to farmers, while 6% arise from any marginal changes through purchases in distant stockists. The implication is that farmers are willing to seek fertilizers irrespective of distance. It is probable that if alternative sources of plant nutrients, other than inorganic chemicals, were available within reach, the farmers would likely buy.

The contact with extension agents (EXTN) positively influences the application of fertilizers and significant at 1%. Regular contacts with extension agents in farm field schools improve farmer knowledge on the use of agricultural chemicals. The extension agents can assist farmers in knowledge in the handling and safe use of chemicals and thus substituting for their lower levels of education. The total expected change in application due to contact is 14%. Of this, 6% comes from marginal increases due to frequency of contacts while 8% arises from the probability of any contact. The different types of contacts that farmers encounter should be used as avenues for informing farmers on increasing application of organic manures and minimization of chemical fertilizers.

There were only three variables that significantly influenced the level of application of fungicides.

These were: period of experience in planting tomatoes (EXPYRS), the member of household that makes decisions (DECIDE), and the tomato cultivar planted (VAR).

The coefficient of EXPYRS was positive and significant at 10%. The total expected change in application of fungicide due to experience in tomato growing is 37%. The influence of changes in applications due to continuous learning is 23% while the small changes in application due to each additional year of experience is 14%. The implication is that farmers who are in the stage of learning to apply fungicides can be an easy target in a pollution reduction strategy especially if integrated pest management methods were incorporated in their husbandry practices.

The person who makes the decision (DECIDE) has a strong influence in the increase of application of fungicides. The total expected change in the application of fungicides due to decision by the husband is 61%. The probability of making a projected decision to apply fungicides would contribute to 36%. Only 25% would arise from minor decisions within the season to apply. An intervention that would influence the entire decision making would be very effective. Deliberate information dissemination targeting heads of household giving alternative ways to reduce fungicide application could produce the desired changes.

The influence of variety of tomato (VAR) contributes the highest to the application of fungicides. The total expected change in application due to the variety of tomato planted is 81%. However, 33% would arise from

Table 4. Tobit model results of factors influencing the application of fungicides in tomato production in Nakuru district

Variable	Maximum Likelihood Coefficient	SE	P[Z >z]	Total change ($\delta E_a^*/\delta X_i$)	Change among farmers usage of fertilizers $F(z)$ ($\delta E_a^*/\delta X_i$)	Expected level of use intensity E_a^* ($\delta F(z)/\delta X_i$)
SITE	0.1687	0.6378	0.7913	0.3640	0.3242	0.0398
GENDER	-0.4934	0.7610	-0.5167	-0.0949	-0.0947	-0.0002
EDUC	-0.1245	0.3791	-0.7426	-0.0239	-0.0239	-0.0000
EXPYRS	0.7205	0.3890	0.0640**	0.3661	0.1384	0.2277
SSNUSE	-0.6011	1.0880	-0.5806	-0.2784	-0.1154	-0.1630
DECIDE	1.2861	0.6809	0.0589**	0.6108	0.2470	0.3638
VAR	-1.7404	0.5635	-0.0020*	-0.8148	-0.3343	-0.4805
DISTOCK	-0.1743	0.2263	-0.4411	-0.0767	-0.0334	-0.0433
EXTN	-0.3517	0.3297	-0.2860	-0.1526	-0.0675	-0.0851
MKTPRI	-0.8125	0.2047	-0.6915	-0.6214	-0.1561	-0.4653

*significant 1%, **significant at 10%.

small changes in applications on various tomato varieties by current users. The largest percentage arises from those anticipating applying fungicides, and forms 48%. Strategies that could appeal to those anticipating applying fungicides on alternative methods that reduce chemicals could have a great impact. Such methods as breeding cultivars that require little or no fungicides would be important. Such methods as breeding cultivars that require little or no fungicides would be important.

Conclusions and implications

This study has demonstrated the use of a decomposed tobit model in deriving important variables for policy aimed at reducing actual and potential use of environmentally unfriendly agricultural chemicals.

While agricultural intensification calls for use of yield enhancing inputs such as fertilizers and fungicides, it is also clear that such systems are unsustainable due to their ecological incompatibility. The need to reduce agricultural pollutants is present and the study reveals the anticipated policy impacts when intervention strategies aimed at curtailing use of agrochemicals are initiated. Clearly, there is no single strategy that can be used to reduce agricultural pollutants as this study has demonstrated that each agrochemical, in this case fertilizers and fungicides is influenced by different variables. The decomposed tobit model allows the making of two sets of policies: those affecting current users and potential users.

Some of the policy recommendations proposed are as follows: first, alternative sources of fertilizer if available would be to reach those anticipating applying fertilizers. This can be accomplished by promoting the most appropriate methods of preparing high quality farm yard manure. Multi-disciplinary research into areas as crop rotations, methods of nitrogen supply through legumes, manure management, weed control and appropriate cultivation methods is needed. Second, is to target potential users of agrochemicals so that their perception can be influenced to accept environmental friendly practices. Third, since the decision to purchase fungicides have a strong influence on the probability of increasing application of fungicides, an intervention that would influence the decision making would be very effective. The heads of households can be given appropriate information through multiple types of extension contacts. The rural population requires greater involvement on environmental issues.

This will create more awareness and promote effective change in farmer behaviour making them more responsive to minimization of hazards at the farm level. Fourth, appointment of environmental and natural resources extension officers in the rural areas in tandem with the initiation and sustenance of environmentally friendly methods would generate a benign situation.

Acknowledgement

Funding support from United Nations Environmental Program, Nairobi (UNEP) for the study is gratefully acknowledged.

References

- Adesina A.A. and Chianu J. 2002. Determinants of farmers' adoption and adaptation of alley farming technology in Nigeria. *Agroforestry Systems* 55(2): 99–112.
- Alavalapati, J.R., Luckert, M.K., and Gill, D.S. 1995. "Adoption of agroforestry practices: a case study from Andhra Pradesh, India." *India Agroforestry Systems*. Kluwer Academic Publishers.
- Amara N., Traore N., Landry R. and Romain R. 1999. Technical efficiency and farmers' attitudes towards technological innovation: the case of tomato farmers in Quebec. *Canadian Journal of Agricultural Economics* 9.47(1): 31–43.
- Anonymous 1987. Food 2000. Report to the World Commission on Environment and Development. Zed Books: London.
- Atkin, J., and Leisinger, K.M. 2000. (Eds). *Safe and effective use of crop protection products in developing countries*. CABI Publishing, UK.
- Baidu-Forson, J. 1999. "Factors influencing adoption of land enhancing technologies in the Sahel. Lessons from a case study in Niger". *Agricultural Systems*, 20: 231–239.
- Burton M., Rigby D., Young T. 1999. "Analysis of determinants of adoption of horticultural techniques in the UK". *Journal of Agricultural Economics*, 9.50(1) 48–63.
- Chandel, B.S., Chakor, I.S., 1998. "Economic evaluation of crop management research recommendation for farmer's adoption: A case study of ginger cultivation in Himachai, Pradesh". *Indian Journal of Agricultural Economics*: 53(1): 53–60.
- Dev V.K. and Hossain M. 1996. Effects of education on technology adoption and aggregate crop output in Bangladesh. *Journal of Agricultural Economics* 19(1/2): 1–15.
- Doss C.R. and Morris M.L. 2001. How does gender affect the adoption of agricultural innovations? The case of improved maize technologies in Ghana. *Agricultural Economics* 25(1): 27–39.
- Garrod G.D. and Willis K.G. 1995. Valuing the benefits of south Downs environmentally sensitive area. *Journal of Agricultural Economics* 46(2): 160–173.
- Karanja, D.D., Jayne, T.S., Strasberg, P. 1999. "Determinants of Input Use and Maize Productivity in Kenya: Implications of Cereal Reform". Conference Proceedings. Tegemeo Institute of Agricultural Policy and Development, Nairobi, Kenya.

- Kimenye, L.N., 2001. "Understanding low rates of technology adoption by women farmers: A case study of determinants of adoption of improved sorghum varieties by women farmers in Mbeere district, Kenya". *Journal of Agriculture, Science and Technology*, 3(1): 30–39.
- Kmenta J. 1986. *Elements of Econometrics*. 2nd edition. Macmillan Publishing Co. New York.
- Kohl, R.L., Uhl, J.N. *Marketing of Agricultural Products*. 1985. McMillan Publishing Company, New York.
- Kruseman G. and Bade J. 1998. Agrarian policies for sustainable land use: bio-economic modelling to assess the effectiveness of policy instruments. *Agricultural Systems*, 58(3): 465–481.
- Lagat, J.K., Ithinji, G.K., Buigut, S.K. 2003. "Determinants of the adoption of water harvesting technologies in the marginal areas of Nakuru district, Kenya: the case of trench and water pan technologies" *Eastern Africa Journal of Rural Development*, 19(1) 25–32.
- Lawrence, P.G., Sanders, J.H., Ramaswamy, S. 1999. "The impact of agriculture and household technologies on women: A conceptual and quantitative analysis in Burkina Faso". *Agricultural Economics*. 9.20(3) 203–214.
- Lynne G.D., Shonkwier J.S. and Rola L.R. 1988. Attitudes and farmer conservation behaviour. *American Journal of Agricultural Economics* 70: 12–19.
- McDonald J.F. and Moffitt R.A. 1980. The uses of tobit analysis. *The Review of Economics and Statistics* 318–321.
- Mose, L.O. 1999. "Factors affecting the distribution and use of fertilizer in Kenya: Preliminary assessment". Conference proceedings. Tegemeo Institute of Agricultural Policy and Development, Nairobi, Kenya.
- Muller, K., Batch, M., Hartman, H., Spittler, M., Frede, H.G. 2002. "Point and non-point source of pesticide contamination in Zwester Ohm catchment area, Germany". *Journal of Environmental Quality*. 31(1) 309–318.
- Nkonya, E., Schroeder, T., Norman, D. 1997. "Factors affecting adoption of improved maize seed and fertilizer in northern Tanzania". *Journal of Agricultural Economics*, 48: 1–12.
- Nkamleu G.B. and Adesina A.A. 2000. Determinants of chemical input use in peri-urban lowland systems: bivariate probit analysis in Cameroon. *Agricultural Systems* 63: 111–121.
- Okigbo, B.N., 1990. Sustainable agricultural systems in tropical Africa. In: C.A. Edwards et al. (eds) *Sustainable Agricultural Systems*, 323–352.
- Shiferaw, B., Holden, S.T. 1998. "Resource degradation and adoption of land conservation technologies in Ethiopian highlands: A case study of Andit Tid North Shewa". *Agricultural Economics*, 18: 233–247.
- Schmidt H. and Jaetzold R. 1983. Farm management handbook of Kenya Vol II. Ministry of agriculture in co-operation with German Agricultural Team of the GTZ.
- Shiyani R.L., Joshi P.K., Asokan M. and Bantilam B.C.S. 2002. Adoption of improved chickpea varieties. KRBHCO experience in tribal region of Gujarat, India. *Agricultural Economics*, 27(1): 33–39.
- Shortle J. and Dunn J. 1991. The economics of control of non-point pollution from agriculture. In: Nick Hanley (Ed.). *Farming and the Countryside: An Economic Analysis of External Costs and Benefits*. CABI: London.
- Stefanides Z. and Tauer L.W. 1999. The empirical impact of bovine somatotropin in a group of New York dairy farms. *American Journal of Agricultural Economics* 1: 95–102.
- Strasberg, P. Jayne T.S., Yamano T., Karanja D., Nyoro J., Strauss, J. (1999) "Effects of Agricultural Commercialisation on Food Crop Input Use and Productivity in Kenya" Conference proceedings Tegemeo Institute of Agricultural Policy and Development, Nairobi, Kenya.
- Woomer, P.L., and Muchena, F.N. 1993. "Overcoming soil constraints in crop production in tropical Africa". In: *Sustaining soil productivity in intensive African agriculture*. Seminar proceedings. Accra, Ghana, 15–19 November 1993.
- WWF 2000. "An Inventory of Pesticides Use on Small scale Farms in Lake Nakuru Catchment" A project report by World Wide Fund, Nairobi.

Assessment of indigenous soil and water conservation technology for smallholder farms in semi-arid areas in Africa and close spaced trash lines effect on erosion and crop yield

Isaiah I.C. Wakindiki^{1*}, B.O. Mochoge² and Meni Ben-Hur³

¹Department of Soil Science, Egerton University, P.O. Box 536, Njoro, Kenya, Email: isaiahwakindiki@hotmail.com; ²Division of Agriculture and Environment, Inter-Governmental Authority on Development, P.O. Box 2653 Djibouti, Email: bmochoe@hotmail.com; ³Institute of Soil, Water and Environmental Sciences, The Volcani Center, Agricultural Research Organization, P.O. Box 6 Bet Dagan, 50250, Israel, Email: meni@agri.gov.il;

* Correspondence author

Abstract

Runoff and soil erosion are responsible for about 83% of the land degradation worldwide. Many smallholder farmers in arid and semi-arid areas of Africa often use inexpensive indigenous soil and water conservation (ISWC) techniques to control runoff and erosion. This paper is a review of the ISWC methods and categorizes them into three: those suitable for semi-arid areas, those suitable for wet areas and those suitable for both semi-arid and wet areas. The usefulness of ISWC is generally appreciated but literature on the subject is scarce. A case study that investigated effects of 2-m spaced trash lines on runoff, erosion and crop yield in a cowpea – maize rotation is presented. Trash lines reduced runoff and soil loss and increased crop biomass yield three-fold. We conclude that ISWC like close-spaced trash lines are beneficial soil and water conservation methods and should be incorporated in future land resource conservation programmes

Key words: Land husbandry, soil degradation, land rehabilitation, arid soils, Africa

Introduction

Much of the semi-arid areas of Africa were covered by savannah prior to 1940s. However, with increased human settlement, much of this area was cleared by slash and burn methods characteristic of subsistence agriculture. Land clearing, heavy grazing and the traditional slash and burn practices have resulted in severe land degradation. Shortened fallows, continuous cultivation and lack of alternative resource for producing food have exacerbated land degradation (Critchley et al. 1994). Once under conventional cultivation, these areas are susceptible to high runoff and soil erosion rates, which result in progressive decline in soil productivity. For example, in Ethiopia, most of the productive topsoil in the highlands has been degraded, resulting

in food shortages and persistent poverty (Krüger et al. 1996). In recognition of the magnitude of this problem since the 1930s, governments across Africa instituted diverse soil and water conservation programmes to counter the massive topsoil loss. These interventions were mainly the permanent physical measures like contour terraces, cut-off drains, ridging, contour ploughing, soil bunds and gabions. For instance, in Machakos district of Kenya, a programme of forced terracing during the 1950s resulted in the construction of around 5,000 km of new terraces each year (Tiffen et al. 1994). Although technologically appropriate, many of these measures failed because they did not take into account the socio-economic and biophysical constraints of the local, resource-poor smallholder farmers who make up to 95% of the farming community in Africa (Reij

1991; Hudson 1992; Okoba et al. 1998). Thus creative approaches that take into account a variety of environmental, economic, social and cultural considerations are urgently required in order to develop adoptable and effective soil and water conservation technologies for the smallholder farmers.

Many smallholder farmers in dry areas use indigenous soil and water conservation (ISWC) techniques (IFAD 1992). These techniques are traditional farming practices that have evolved over time, without any known outside institutional intervention and have some conservation effect (Krüger et al. 1996). They are mostly developed in response to prevailing environmental and socio-economic constraints (Martin et al. 1998) of the poor smallholder farmers. Critchley et al. (1994) observed that ISWC has been most commonly developed either under dry and marginal conditions, steep slopes, or where moisture limits crop production. These conservation practices are often not only used to reduce soil loss or manage runoff, but are often introduced to improve productivity and the suitability of land to cultivation (Krüger et al. 1996). Wakindiki et al. (2001) observed widespread use of ISWC techniques in the semi-arid Tharaka district of Kenya. Regrettably, the agricultural community has neglected research on ISWC, partly because semi-arid areas are considered to have lower potential. Moreover, historically rooted cultural and political considerations have hampered research on ISWC in dry areas. The predominantly smallholder farmers usually lack the necessary socioeconomic influence to attract political attention and research policy support (Chambers 1983). Nevertheless many smallholder farmers continue to use inexpensive simple ISWC techniques (Wakindiki et al. 2001).

Characteristics of cultivated semi-arid areas in Africa

Climate

Many parts of the semi-arid areas are characterised by temporal and spatial variability of climate, landscape and relief. In general, in many parts of African drylands, the rainfall pattern is bimodal, and usually low and unreliable. The timing and relative lengths of each growing period vary substantially with location. Annual rainfall averages range from 408–751 mm in the lower elevations of Mandara mountains of Cameroun and the eastern part of the rift mountains in Morocco,

about 562 mm in the Yatenga region in Burkina Faso and 600 mm in the Mbeere area, eastern Kenya (Reij et al. 1996). However, the rainfall when it does occur is intense and frequently exceeds the infiltration capacity of the soil and can cause crusting, runoff and soil erosion (Wakindiki and Ben-Hur 2002a). The amount of rainfall that occurs within erosive events determines the erosion hazard. According to Wischmeier and Smith (1978), an erosive rainfall event is defined as a storm that results in more than 12.5 mm or rainfall intensity during a storm that exceeds 6.4 mm during a 15-minute period. Using this rationale, approximately 95% of rainfall in the cultivated semi-arid areas of Africa is erosive.

The average monthly temperature varies ranging from less than 25 °C in the hills to as high as 31 °C in the lower elevations. Generally the high temperatures coupled with low humidity make the crops frequently experience moisture stress as a result of high evapotranspiration.

Land use and economy

Many farmers grow drought tolerant crops such as sorghum (*Sorghum bicolor*), millet (*Panicum miliaceum*), cowpeas (*Vigna unguiculata*), and cassava (*Manihot esculentum*). Maize (*Zea mays*), beans (*Phaseolus vulgaris*), groundnuts (*Arachis hypogea*) and cotton (*Gossypium hirsutum*) are also grown either for food or cash. There is continued use of low yielding unimproved varieties, which together with the limited use of fertilizers has further reduced crop yields. Farmers also keep a variety of livestock for various reasons ranging from religious and social roles (e.g. sacrifices and feasts) to provision of organic manure and cash when sold in case of an emergency. Due to variability and unreliability of rainfall, the returns to agricultural investment are always low.

Indigenous soil and water conservation methods

Soil erosion involves two major processes: (i) detachment of soil particles from the soil surface; and (ii) transport of the resulting sediment (Watson and Lafen 1986). In semi-arid areas productive gains on arable lands are realised by retaining water so as to increase infiltration (Wakindiki and Ben-Hur 2002b). Different types of conservation structures were introduced

in Africa in response to mounting international concern about soil erosion in the 1930s, which led to a policy of direct intervention in African farming practices. This ecological crisis was particularly evident in many semi-arid parts of the continent (Reij et al. 1996).

The most limiting factors for plant growth in many semi-arid areas are soil moisture and nutrients (Briggs et al. 1998). Hence resource-poor farmers in many drought-prone areas of Africa are known to conserve moisture and soil as an integral part of their farming systems using ISWC techniques. Critchley et al. (1994) categorised ISWC techniques according to the type of technology into two: soil and water conservation (SWC) and water harvesting (WH) systems. They observed that SWC techniques aim to conserve soil and water *in situ* whereas WH techniques collect and concentrate rainfall runoff for improved plant growth. In this review we attempt to identify the ISWC techniques that are most suitable for the semi-arid areas and classify them according to the intended goal. We hypothesise that the choice of ISWC technique should depend on the rainfall received in a given area.

Trashlines and stone bunds

The trash line technique uses lines made of crop material that remains after harvesting. The material is formed into ridges across the slope and sometimes modified by inclusion of logs or pegs (Gichuki 1992). They are temporary structures laid seasonally, and are sometimes moved to a new position in the field to exploit trapped fertility gains (Tengberg et al. 1998). According to Briggs et al. (1998), trash lines are traditionally used in fields with 10–30 % slopes. Different dimensions and spacing as practised by farmers have given rise to different structures depending on availability of materials and tools. Thus we have large and small, fixed and mobile trash lines, spaced about 15 m apart. Trash lines are found in many parts of Africa where cereals are grown (Table 1). In semi-arid regions, seal formation is a common occurrence that decreases the infiltration rate and increases runoff and soil erosion (Ben-Hur et al. 1985). The raindrop impact energy causes the soil surface structure to break down and consequently a seal is formed. This seal is thin (<2 mm) and is characterised by greater density, higher strength, finer pores, and lower saturated conductivity than the underlying soil (Ben-Hur et al. 1985). Hence, under seal-formation conditions, the 15 m spacing between the trash or stone lines is probably too large to prevent

surface runoff and soil erosion out of the cultivated field during rainstorms. Furthermore, under seal-formation conditions, the trash, that covers the soil surface limit seal formation on the area beneath it. Hence, the surface runoff that flowed across the area between the trash lines could infiltrate in the area beneath the trash, thus decreasing the total runoff. Consequently, the width of the trash line affects the area of the soil surface with no seal, which, in turn can affect the amount of infiltrated water and the runoff in the field.

The stone line technique, in which the stones are arranged in lines across the slope, is used where stones are abundant on the soil surface. The size of stone lines varies depending on availability of stones and the topography. In sloping areas and where stones are readily available, stone bunds are closer together and relatively higher and wider than in areas with gentle slope and where stones are scarce. Okoba et al. (1998) and Wakindiki et al. (2001) in their studies in Mbeere and Tharaka in Kenya, respectively, found that stone lines were effective in controlling runoff and soil loss. This resulted in improved crop yields attributed to increased soil moisture infiltration and hence available water for crop production, as well as reduction in nutrient losses.

The trash and stone line techniques differ in some aspects. For example, in contrast to stone lines, trash lines allow water to infiltrate into the soil in the area directly beneath them, and the trash rots after a few seasons thus adding organic matter to the soil. The trash line technique requires less labour to construct but frequent maintenance, whereas the stone line technique requires more labour to construct but little maintenance (Wakindiki et al. 1998). The trash and stone line techniques both form semi-permeable barriers across the slope that decrease the surface runoff velocity and increase the infiltration duration of the impounded water, but allow passage of excess runoff. As a result, the amount of infiltrated water increases and the runoff volume and its erosive power decrease. Likewise, retention of sediment in the trash and stone lines results in reduced soil and nutrient losses (Gachene et al. 1997).

Pitting and micobasins

The pits, usually 20–30 cm wide and 10–15 cm deep, act as micro-catchments, concentrating and holding rainfall from the area between them. They are made in lines across the field, the farmer add manure to each pit

Table 1. Examples of indigenous soil and water conservation (ISWC) techniques in Africa

Country	Region	Rainfall, mm	ISWC techniques	Major crops
Burkina Faso	Yatenga	400–700	Pitting, stone bunds	Millet, Sorghum
Cameroon	Central	400–800	Trash lines, stone bunds	Millet, Sorghum
Cape Verde	Mandara	800–1100	Stone bunds	Sorghum, Peanuts
Ethiopia	S. Antao	400–1200	Stone terraces	Sugarcane, Maize
	Konso	High	Rectangular basins	Maize, Millet
	Shewa	1350	Drainage ditches	Barley, Pulses
Ghana	Upper East	800–900	Stone bunds	Millet, Groundnuts
Kenya	Tharaka	600	Trash lines; stone bunds	Maize, Millet
	Rift valley	>650	Trash lines; stone bunds	Maize, Millet
Malawi	South	500–1300	Vegetative, Trash lines	Maize, Sorghum
Mali	Djenne-Sofara	400	Pitting, Trash lines	Sorghum, Millet
	Dogon plateau	500	Basins, stone bunds	Vegetables
Niger	Ader Doutchi	300–500	Stone bunds, Pitting	Sorghum, Millet
	Tahoua	350–450	Pitting	Sorghum, Millet
Nigeria	Borno State	250–500	Earth bunds, Trash lines	Sorghum
	Jos plateau	1000–1500	Micro-basins	Vegetables, Wheat
Rwanda	Northwest	1100–1400	Bench terraces	Bananas, Beans
Sierra Leone		2000–2500	Drainage ditches	Rice, Cassava
Somalia	Hiraan	150–300	Earth bunds, Trash lines	Sorghum, Cowpeas
South Africa	Transkei	750–1400	Earth bunds	Maize
Sudan	West	50–800	Water harvesting	Sorghum,
	Djebel Marra	600–1000	Bench terraces	Vegetables, Millets
Tanzania	Uluguru	1500	Trash contour ridges	Vegetables
	Southwest	1000	Ridging	Maize, Manioc
Tchad	Ouddal	250–650	Earth bunds	Millets
Togo	North	1400	Bench terraces	Yam, Rice, Millet
Uganda	Southwest	800–1000	Ridging, Trash lines	Bananas
Zimbabwe	Masvingo	400–600	Contour ridges, Trash lines	Maize, Millet

After Critchley et al. (1994); Reij et al. (1996); Wakindiki and Ben-Hur (2002b).

before the first rainfall. The manure further enhances growing conditions and simultaneously attracts soil-improving termites (Critchley et al. 1994). Larger, deeper pits are typically found on steeper slopes for example the *Matengo* or *Ngoro* pits practised by the Matengo people in the Mbinga district, southwest Tanzania with average of 2.4 m long by 2.1 m wide aligned down the slope. In general the pit depth ranged from 0.3–0.5 m on gentle slopes (2–10%) to 0.1–0.14 m on steep slopes (>40%) (Martin et al. 1998; Ellis-Jones et al. 1998). The crops are planted on the surrounding ridges; under which plant residues are decomposing. Crops also benefit from moisture stored in the adjacent pits (Willcocks and Twomlow 1993).

Studies by Martin et al. (1998) showed that the *Ngoro* pits were very effective in controlling runoff and erosion. They observed that although they are prone to damage by pedestrian traffic, the net loss of soil from the system was negligible, as the majority of the soil was redeposited in the pit. They also observed that *ngoro* gives a uniform crop growth around the bund due

to uniform soil moisture profile and this enhanced crop yields. They concluded that larger pits were more suitable than small ones as they reduce labour and increase yields hence profitability of the system. Enlarged planting holes, or pits, are features on relatively flat semi-arid regions of west Africa and the technique is growing in importance in the Djenne-Sofara region of Mali (Reij 1991) as well as on the Dogon plateau, Mali (Kassogue et al. 1996; Table 1).

Earth bunds and terraces

Earth terrace structures are of two basic types; levelled bench terraces and earth bunding on existing slopes. Notable examples include the *Fanya-juu* earth bunding system in Kenya, the ladder terraces of the Uluguru Mountains in Tanzania and in Rwanda where narrow earth-terraces termed *inyanamo* are constructed on steep slopes. In Ethiopia, soil bunds are found most often in Woindega and Kolla zones, especially in fields where

chat, maize and sorghum are cultivated. *Fanya juu* is a swahili term meaning, “make it up”. A type of backslope trench is dug and soil from the trench is thrown upslope to form a riser bank. The trench is meant to level on the contour, trapping rainfall that is retained to percolate into the field below the ditch. They are spaced at 15 m intervals and the bank is sometimes planted with grass. In the Transkei, South Africa, earth contour bunds are common in the marginal unproductive mountainous interior areas. They are constructed 0.5 m high and 2 m wide and are planted with grass to stabilise them (Table 1).

Vegetative strips

Narrow grass strips, created by leaving strips of land unploughed across the slope are traditionally used in a number of countries to control runoff and soil erosion. Different naturally occurring grasses are preferred in different regions. For example *Hyparrhenia* sp which is also used for thatching is a common choice in Swaziland. Vetiver grass is traditionally used for soil conservation in several African countries (Critchley et al. 1994). Live fencing surrounding cultivated fields has been used in many areas to provide protection against erosion.

Drainage ditches

These are traditional diversion ditches that are used to protect the cultivated fields from potentially erosive runoff (Table 1). Gichuki (1992) reported use of retention ditches in steep areas of Kenya, where runoff is captured and allowed to infiltrate.

From the foregoing review ISWC techniques invariably aim to (i) prevent soil particle detachment and conserve water *in situ*, (ii) halt the transportation of soil particles by either reducing the runoff flow velocity or the slope length and gradient, (iii) safely dispose excess runoff from the cultivated field. The ISWC techniques that prevent soil particle detachment and conserve water *in situ* include pitting and micro-basins. These methods are characteristically found in low rainfall areas (Table 1). Vegetative strips, trash lines, earth bunds and stone bunds aim to halt the transportation of soil particles by runoff. These methods appear in both semi arid and wet areas except in the case of vegetative strips that is mostly in wet areas (Table 1). Drainage ditches provide pathways for safe disposal of

excess runoff from the cultivated field and are common in higher rainfall areas (Table 1). Therefore it can be deduced that ISWC techniques like pitting and micro-basins aim to conserve water *in situ* are likely to be found in semi-arid areas. Those ISWC techniques that prevent the transportation of soil particles by either reducing the runoff flow velocity or the slope length and gradient like trash lines and earth bunds are found in both semi-arid and wet areas, while drainage ditches appear restricted to high rainfall areas (Table 1). We conclude that ISWC techniques can be categorised according to the intended goal into three: those suitable for semi-arid areas, those suitable for wet areas and those suitable for both semi-arid and wet areas.

A Case study of close spaced trash lines effect on erosion and crop yield

Table 1 shows an overwhelming presence of trash lines across Africa. However little quantitative data is available on their effectiveness in controlling runoff, soil loss and improving crop yields. A study was done to investigate the effects of 2-m spaced trash lines on runoff, erosion, and crop yields during consecutive rainy seasons under semi-arid conditions in Tharaka, eastern Kenya.

Materials and methods

Experimental site

The experiment was conducted at Tunyai in eastern Kenya. The site is located at approximately 37° 50'E and 0° 2'S. The long-term average annual rainfall in this region is 600 mm, which is distributed almost equally between two rainy seasons: March–May and October–December, referred to as seasons 1 and 2, respectively. The land at the experimental site was under fallow for about 5 years being used for cattle grazing. In February 1997, this land was cleared and cultivated with hand tools. Twelve runoff plots measuring 2 m by 6 m each were constructed along a contour on a 10% slope.

Experimental design

Three treatments, each with 3 replicates, were randomly assigned to the runoff plots. The treatments

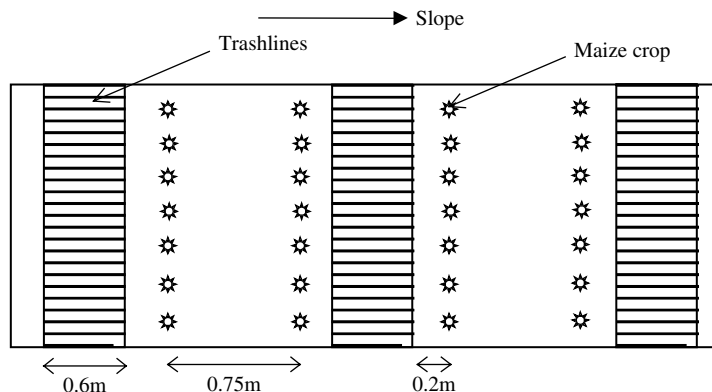

Figure 1. Schematic layout of the runoff plot with trash lines.

were: (1) big trash lines with trash content of 2.5 t ha^{-1} ; (2) small trash lines with trash content of 1.5 t ha^{-1} ; and (3) control without trash lines. All the trash lines were aligned along the contour at a 2-m spacing (Fig. 1). Agronomic aspects (e.g. time of planting, plant population, etc.) at the experimental site were in accordance with the local practices and conditions. *Katumani* composite, drought-tolerant maize (*Zea mays* L.) variety, was planted as a sole crop during the first season of each year of the study. The spacing between the maize plants was 0.25 m within the rows and 0.75 m between the rows. Two rows were planted between the trash lines, in the plots where these techniques were applied. In the second season in each year of the study, maize was intercropped with cowpea (*Vigna unguiculata*) variety M66 in all the treatment plots. A single row of this crop was planted between the two rows of maize at a spacing of 0.25 m within the row. The spacing between the plants in the control treatment was the same as in the other treatments. At the end of each season, the crop was harvested by hand and the dry weights of crop grains and straw from each plot were determined. The runoff in each runoff collecting tank was mixed thoroughly and 3 sub-samples were taken to determine the amount of soil loss by weighing the sediment after oven drying at 105°C . The daily rainfall was recorded with a rain gauge at the nearby Tunyai meteorological station.

Statistical analysis

Data were analyzed as a complete randomized design using procedures described by Steel and Torrie (1997) for Analysis of Variance. Separation of means was

tested using Turkey's honestly significant difference with a 0.05 level of significance.

Results

Seasonal distribution of rain

The distribution of rain for 5 consecutive rainy seasons is presented in Fig. 2. The pattern of rainfall distributions over the five seasons showed marked variations in both frequency of storms and amount of rainfall. The 2 rainy seasons in 1997 showed a normal distribution pattern of daily rainfall. In season 1, the total rainfall in this season was 507 mm, which was 44% higher than the long-term average (Fig. 2). In season 2 of 1997, the total rainfall in this season was 1334 mm, which was 4.3 times greater than the long-term average. The total rainfall in season 1 of 1998 was 611 mm, which was 73% higher than the long-term average. The total rainfall in season 2 of 1998 was 253 mm, which was similar to the long-term average value. Rainfall distribution during season 1 of 1999 was skewed towards the end of the season (Fig. 2). The total rainfall in this season was 243 mm, which was similar to the long-term average.

Effects of trash lines on erosion and crop yield

Runoff during the 5 rainy seasons and for the various treatments is presented in Fig. 3, as relative percentages. The relative runoff percentage in the control treatment was higher, in all cases, than those in the trash lines treatments (Fig. 3). Seasonal soil

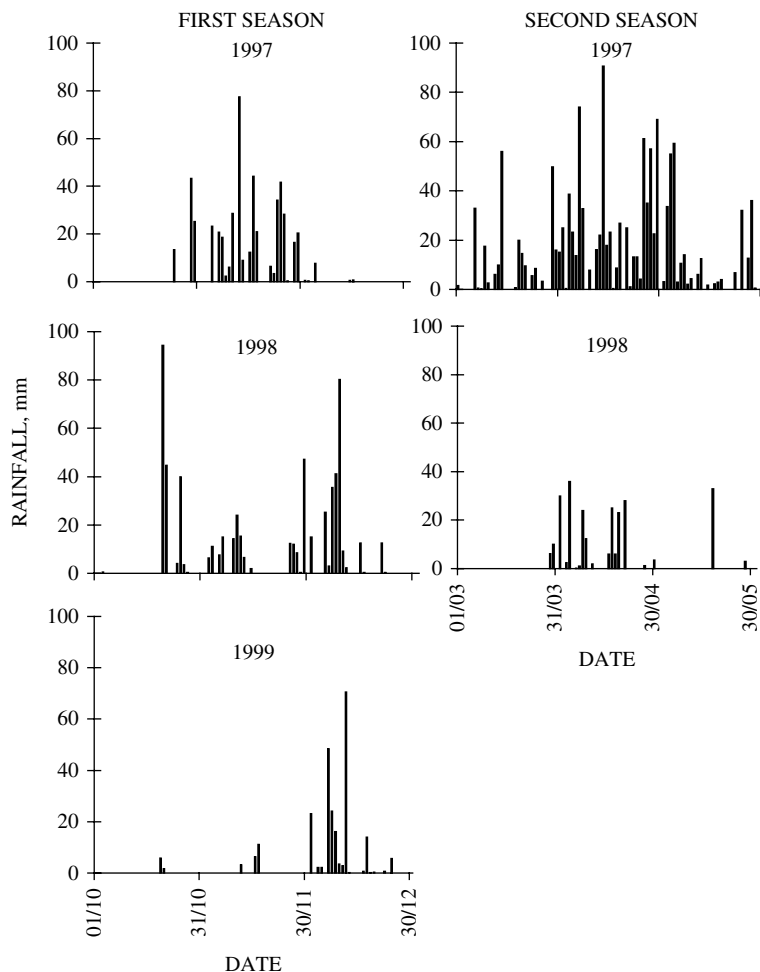

Figure 2. Distribution of daily rainfall for five consecutive rainy seasons.

losses in the various rainy seasons and under the various treatments are presented in Table 2. The soil losses in the control treatment were relatively high, ranging from 0.47 Mg ha^{-1} in season 1 of 1999 to 0.84 Mg ha^{-1} in season 2 of 1997 (Table 2). Trash lines significantly ($P \leq 0.05$) decreased the soil loss compared with the control treatment during all the rainy seasons. The yields, of grain and stover, of maize and cowpea in the various rainy seasons and under the various treatments are presented in Table 3. Cowpea was grown as an intercrop only in seasons 2 of 1997 and 1998; therefore, Table 3 presents the cowpea yields only for those seasons. The grain yield of maize in the control treatment ranged from 0.16 Mg ha^{-1} in season 1 of 1999, with seasonal rainfall of 243 mm, to 0.56 Mg ha^{-1} in season 2 of 1997, with seasonal rainfall of 1334 mm

(Tables 2 and 3). The same general trend was found in the stover yield of the maize in this treatment. The grain yields of cowpea in the control treatment were 0.44 and 0.59 Mg ha^{-1} in season 2 of 1997 and 1998, respectively, and their stover yields were 2.09 and 1.94 Mg ha^{-1} , respectively (Table 3). The total crop biomass (grain plus stover of maize and cowpea) in the consecutive rainy seasons was 1.67 , 4.51 , 2.03 , 3.43 , 0.83 Mg ha^{-1} , respectively, in the control treatment (Table 3).

Discussion

The significant variations in rainfall distribution among the various rainy seasons (Fig. 2) are typical of a semi-arid region. Generally, daily runoff was associated with

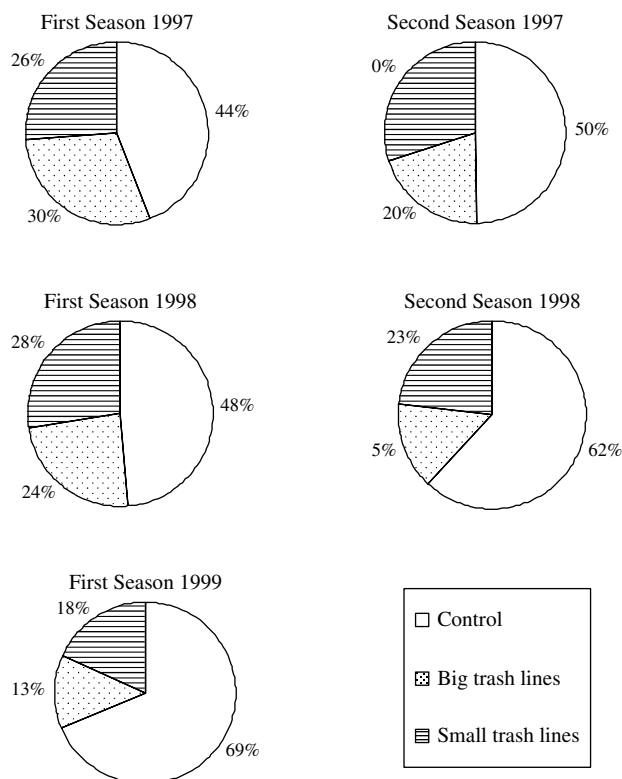

Figure 3. Seasonal runoff as relative proportions during the five rainy seasons and for the various treatments.

rainfall >30 mm (Figs 2 and 3), but, on some days, rainfall >30 mm did not generate runoff. The mechanism that could account for the reduction of the runoff by the trash lines is that the trash lines decreased the runoff velocity along the slope, thus, in turn, increasing

the duration of infiltration and the amount of infiltrated water. Also, the trash that covered the soil surface reduced seal formation and increased the infiltration rate in the area beneath the trash; in these cases, the high infiltration rate in the area beneath the trash decreased the total runoff from the treated plot. The lower runoff that was obtained with the small trash lines (Table 2) indicated that the small lines of trash were not efficient in decreasing the runoff velocity or in increasing the infiltration rate in the area below the trash. However, the larger size of the trash line increased these efficiencies.

Results of the seasonal soil losses in the various rainy seasons and under the various treatments indicate that the effect of the trash lines in decreasing soil loss was not only by reduction of the surface runoff. Trapping of the sediments as the excess runoff passed through the trash was probably another mechanism that decreased the soil loss.

Crop yield results indicate that the trash lines were most effective in increasing the yields in season 1 and

Table 2. Soil loss (Mg ha^{-1}) for the various rainy seasons and treatments. Within rows, values followed by the same letters are not significantly different at $P \leq 0.05$

Season	Control	Big trash Lines (Units?)	Small trash lines
1, 1997	0.69 a	0.26 c	0.44 b
2, 1997	0.84 a	0.43 c	0.53 b
1, 1998	0.56 a	0.15 c	0.21 b
2, 1998	0.79 a	0.24 c	0.35 b
1, 1999	0.47 a	0.09 c	0.10 b

Table 3. Seasonal yields (Mg ha^{-1}) of maize and cowpea in the five rainy seasons and under the various treatments. Within rows, values followed by the same letters for grain or straw are not significantly different at $P \leq 0.05$

Season	Control		Big trash lines		Small trash lines	
	Grain	Straw	Grain	Straw	Grain	Straw
—Maize—						
1, 1997	0.42b	1.25b	0.74a	2.1a	0.54b	2.02a
2, 1997	0.56c	1.42c	1.22a	4.2a	0.84b	3.82b
1, 1998	0.54c	1.49c	1.47a	3.2a	0.86b	2.52b
2, 1998	0.25d?	0.65c	1.11a	2.84a	0.66c	1.51b
1, 1999	0.16b	0.67b	0.42a	0.86a	0.46a	0.84a
—Cowpea—						
2, 1997	0.44b	2.09a	0.56a	2.05a	0.41b	2.16a
2, 1998	0.56c	1.94d	0.94a	2.39b	0.84b	2.55a

2 of 1998. This high effectiveness of the trash lines was probably a result of the rainfall distribution, i.e. rainfall depth and intervals between the rainstorms, in season 1 and 2 of 1998. A possible reason for the increased crop yields is the lower runoff in the plots where the trash lines were applied, which in turn, increased the water infiltration in these plots.

Conclusions

The 2-m spaced trash lines probably decreased the runoff velocity along the slope, which in turn, increased the duration of infiltration and the amount of infiltrated water. Also, the trash lines limited the seal formation in the area beneath them, which led to increased infiltration and decreased runoff. The decrease of the soil loss was due to the action of the trash lines in reducing runoff and in trapping the sediments. The main reason for the increased crop yield in the trash lines treatments was the lower runoff in these treatments that increased the available water for crop production.

Acknowledgments

The International Foundation for Science (IFS) supported this research under grant number C/2641 to Dr Isaiah I.C. Wakindiki.

References

- Ben-Hur M., Shainberg I., Bakker D. and Keren R. 1985. Effect of soil texture and CaCO₃ content on water infiltration in crusted soils as related to water salinity, *Irrigation Science* 6: 281–284.
- Briggs S.R., Ellis-Jones J., Miiro D.H. and Tumuhairwe J. 1998. Soil and water conservation in the farming systems of Kamwezi, south west Uganda. In: Briggs, S.R., Ellis-Jones J. and Twomlow S.J. (Eds), *Modern methods from traditional soil and water conservation technologies. Proceedings of a DFID land management workshop. Jan 13–15, 1998. The White Horse Inn, Kabale, Uganda.*
- Chambers R. 1983. *Rural development: Putting the last first.* Longman, London.
- Critchley W.R.S., Reij C. and Willcocks T.J. 1994. Indigenous soil and water conservation: A review of the state of knowledge and prospects for building on traditions. *Land Degradation and Rehabilitation* 5: 293–314.
- Ellis-Jones J., Dihenga H., Tenberg A., Nyenza E. and Twomlow S. 1998. Farmers' decision making in soil and water conservation: an example from Tanzania. In: Briggs S.R., Ellis-Jones J. and Twomlow S.J. (Eds), *Modern methods from traditional soil and water conservation technologies. Proceedings of a DFID land management workshop. Jan 13–15, 1998. The White Horse Inn, Kabale, Uganda.*
- Gachene C.K.K., Jarvis N.J., Linner H. and Mbuvi J.P., 1997. Soil erosion effects on soil properties in a highland area of central Kenya. *Soil Science Society of America Journal* 61: 559 – 564.
- Gichuki F.N. 1992. *Indigenous land husbandry practices.* Report OD/92/9. Silsoe Research Institute, Silsoe.
- Hudson N.W. 1992. *Soil Conservation.* Batsford, London.
- International Fund for Agricultural Development 1992. *Soil and water conservation in sub-Saharan Africa. Towards sustainable production by the rural poor.* IFAD, London.
- Kassogue A., Momota M., Sagara J. and Schutgens F. 1996. A measure for every site: traditional soil water conservation techniques on the Dogon plateau, Mali. In: Reij C., Scoones I. and Toulmin C. (Eds), *Sustaining the soil: Indigenous soil and water conservation in Africa.* Earthscan Ltd, London 260pp.
- Krüger H.J., Fantaw B., Michael Y.G. and Kajela K. 1996. Creating an inventory of indigenous SWC measures in Ethiopia. In: Reij C., Scoones I. and Toulmin C. (Eds), *Sustaining the soil: Indigenous soil and water conservation in Africa.* Earthscan Ltd, London 260pp.
- Martin L., Kayombo B., Dihenga H., Nyenza E., Twomlow S. and Willcocks T. 1998. Traditional soil and water conservation systems in Southwest Tanzania. In: Briggs S.R., Ellis-Jones J. and Twomlow S.J. (Eds), *Modern methods from traditional soil and water conservation technologies. Proceedings of a DFID land management workshop. Jan 13–15, 1998. The White Horse Inn, Kabale, Uganda.*
- Okoba B., Twomlow S. and Mugo C. 1998. Evaluation of indigenous soil and water conservation technologies for runoff and soil loss control in semi-arid Mbeere district, Kenya. In: Briggs S.R., Ellis-Jones J. and Twomlow S.J. (Eds), *Modern methods from traditional soil and water conservation technologies. Proceedings of a DFID land management workshop. Jan 13–15, 1998. The White Horse Inn, Kabale, Uganda.*
- Reij C. 1991. *Indigenous soil and water conservation in Africa.* IIED Gatekeeper series No 27, IIED, London.
- Reij C., Scoones I. and Toulmin C. (Eds). 1996. *Sustaining the soil: Indigenous Soil and Water Conservation in Africa.* Earthscan, London.
- Steel R.G.D. and Torrie J.H. 1997. *Principles and procedures of statistics: a biometrical approach.* McGraw-Hill, London.
- Tengberg A., Ellis-Jones J., Kiome R. and Stocking M. 1998. Agro-diversity: Applying the concept to indigenous soil and water conservation practices in eastern Kenya. In Briggs S.R., Ellis-Jones J. and Twomlow S.J. (Eds), *Modern methods from traditional soil and water conservation technologies. Proceedings of a DFID land management workshop. Jan 13–15, 1998. The White Horse Inn, Kabale, Uganda.*
- Tiffen M., Mortimore M. and Gichuki F. 1994. *More people, less erosion. Environmental recovery in Kenya.* Wiley-Chichester, London.
- Wakindiki I.I.C., Runguma D., Mochoge B.O. and Ben-Hur M. 2001. Technical note on local adaptations to soil erosion and low soil moisture in Tharaka district, Kenya. *Tanzania Journal of Agricultural Sciences*, 1: 75–80.
- Wakindiki I.I.C. and Ben-Hur M. 2002a. Soil mineralogy effects on crust micromorphology, infiltration and erosion. *Soil Science Society of America Journal* 66: 897 – 905.

- Wakindiki I.I.C. and Ben-Hur M. 2002b. Indigenous soil and water conservation techniques: effects on runoff, erosion, and crop yields under semi-arid conditions. *Australian Journal of Soil Research* 40: 367–379.
- Wakindiki I.I.C., Mochoge B.E., Ben-Hur M. and Runguma D. 1998. Socio-cultural and economic aspects of indigenous soil and water conservation in the semiarid Tharaka, eastern Kenya. In: *Proceedings of International Symposium on Arid Region Soil*. Pp. 426–431. Menemen-Izmir.
- Watson D.A. and Laffen J.M. 1986. Soil strength, slope, and rainfall intensity effects on interrill erosion. *Trans. ASAE*. 29 98–102.
- Willcocks, T.H. and Twomlow, S.J., 1993. A review of tillage methods and soil and water conservation in Southern Africa. *Soil and Tillage Research* 27: 73–94.
- Wischmeier W.H. and Smith D.D. 1978. *Predicting rainfall erosion losses- a guide to conservation planning*. USDA, Science and Education Administration, Agriculture Handbook No. 537, Washington DC.

***Prosopis africana* (Guill., Perrot et Rich.) Taub and *Entada africana* (Guill. et Perrot.) leaf litter decomposition and impact of biomass transfer on millet (*Pennisetum glaucum* (L.) R. Br.) growth and development on station in Niger.**

Larwanou Mahamane^{1*}, Harouna Niandou Abdel-Aziz², Abasse Tougiani³ and Niang Amadou⁴

¹*Enseignant – chercheur, Faculté d’Agronomie, Université Abdou Moumouni de Niamey, BP 10960, niamey, Niger; Tel: +22720315237 (Office); +22796973442 (Cell), E-mail: m.larwanou@coraf.org; ²IPR de Katibougou, Mali;

³Département de Recherches en Gestion des Ressources Naturelles (DGRN), Institut National de la Recherche Agronomique du Niger (INRAN), BP 429, Niamey, Niger; Tel : +227 970886/742967; Fax : +227 722252; E-mail: sareli@intnet.ne; ⁴ICRAF/Sahel, BP 320, Bamako, Mali; Tel: +223 2235000; E-mail: a.niang@icrisatml.org

Abstract

A study on leaf litter decomposition of *Prosopis africana* and *Entada africana* and impact of biomass transfer on millet growth was carried out at N’Dounga Forestry Research Station in Niger. The objective of the study was to assess the potentials of leaf biomass transfer and decomposition of the two species on soil fertility and growth and development of millet in an arid environment. Leaf biomass of the two species was obtained from trees of 10 years of age. Decomposition was monitored using litterbag method. Leaf biomass was spread and then buried on millet plots in order to monitor the impact on millet growth and development. The experimental design was a factorial with 2 factors (species at 2 levels and fertilisation (F) at 4 levels: F1 = control, F2 = 1.5 t ha⁻¹, F3 = 2.5 t ha⁻¹, F4 = 5 t ha⁻¹) in a randomized block design with 3 replications.

The results showed that *P. africana* leaf litter decomposed more rapidly than that of *E. africana*. In 14 weeks, 49% of *P. africana* leaf litter was decomposed as against 25% for *E. africana*. The speed of mobility of mineral nutrients of the two species leaf litter was Mg > N > Ca > P, K for *P. africana* with respectively 16, 18, 58, 10 and 21% for these mineral elements in 2, 4, 6 and 12 weeks; Mg > K > Na > N, P for *E. africana* with respectively 22, 3, 49, 32 and 35% of mineral elements in 2, 4, 6 and 12 weeks.

The mineral nutrients N, P, K, Mg, Na in the soil after decomposition on millet plots were more important at 10–30cm soil depth with respectively 0.008 ; 1.75 ; 0.04 ; 0.31 and 0.04 compared to the situation before applying leaf biomass with 0.01 ; 3.6 ; 0.03 ; 0.93 and 0.03.

P. africana leaf biomass application gave better millet growth in height (61±52.53 cm) during 4 weeks compared to *E. africana* leaf biomass (40.59±30.81 cm) against 37.45±25.99 cm for control. For the two tree species, the quantity of 2.5t ha⁻¹ of leaf biomass gave better millet growth in height whereas, the quantity of 1.5t ha⁻¹ gave better response in number of stalks with time. Important stalks dry biomass of 167 t/ha was obtained when 1.5 and 2.5t/ha of *P.africana* leaf biomass was applied. This quantity is 3 times than that of control

Key words: Biomass transfer, *Entada Africana*, Leaf litter decomposition, millet, Niger *Prosopis africana*

Introduction

In dry tropical Africa and particularly in the Sahel, rural population lived in perfect harmony with its environment (Soumeylou 1996). Nowadays, there is a forced divorce. This situation is the result of multiple factors of climatic and anthropic nature: drought, bush fires, overgrazing, reduction of pasture lands, and itinerant agriculture with short fallow. A decrease in soil fertility and reduction of vegetation cover occurred because natural fertilisation could not compensate nutrient elements losses. Soil fertility management debates were held to address the issue of sustainability of agricultural production systems in Africa and particularly in sub Saharan Africa (Kanté 2001). One of the solutions was the intensive application of mineral fertilizer (Baumer 1987; Gros 1967). The impact of this recommendation could not last longer under the socio-ecological conditions of smallholding farmers (Baumer 1987).

Many other debates were held to facilitate better understanding of factors that contribute to loss of soil fertility and potential solutions to catalyse future participation in project and experimental programmes. The idea behind these initiatives was to regenerate the capital for soil fertility (contributions of rock phosphates, liming, introduction of nitrogen fixing species, stopping soil erosion, etc) and to take permanent actions of protection, maintenance, improvement of restored fertility.

Agroforestry practices could be an alternative to upraise level of soil fertility by using ligneous species in alley cropping, parklands, mulching, etc. (Bernand, 1996) Among ligneous species used in agroforestry, nitrogen fixers are more prominent in increasing soil fertility (Baumer 1987; Wood and Burley 1993). These species provide fodder, traditional medicine, firewood, timber, nonwood products, protect soils against wind, enrich them with nitrogen and other nutrients elements; they consequently contribute to increase crop production (Iktam and Kho 1996). Ligneous species could then be considered as source of soil nutriment (Laudelot and Meyer, 1954 and Mainguet, 1995). Many research works were conducted on nitrogen fixing trees Baumer (1987), Vandenbelldt and Renard (1991) on *Faidherbia albida* Mann and Saxena (1981) on *Prosopis cineraria* in India; Janssen (1993), Kang et al. (1990) on *Leucaena leucocephala* and Larwanou (1994) on *P. africana* in Ibadan (Nigeria) in a humid environment.

To test this alternative of enhancing soil fertility by valuing indigenous species, a study was carried out

with two nitrogen fixing species (*Prosopis africana* and *Entada africana*). These two species produce significant quantities of foliar biomass in rainy season, thus, appropriate for biomass transfer. The objective of this study was to investigate the potentials of the two species to enhance soil fertility and to increase agricultural production by applying foliar biomass as green manure. This study could contribute to develop a cheap and easily accessible technological package for poor Sahelian farmer and could help in the struggle to increase agricultural production through the improvement of soil fertility.

Material and methods

Study site

The study was conducted at N'Dounga forestry Research Station located 30 km South-east of Niamey on longitude 2°18' 28" North and latitude 13°25' 00" East. The average annual rainfall is 500 mm and average annual maximum and minimum temperatures are respectively 36.9 °C and 22.7 °C. The soil types are clayey, silt and sandy soils.

Plant materials

The plant materials are composed of foliar biomass of *P. Africana*, *E.africana* and millet (*Pennisetum glaucum* (L) R.Br).

Leaf litter decomposition

Nylon mesh bags (not biodegradable) were used for leaf litter decomposition (Larwanou 1994; Magde 1969). Mesh size was 2 × 2 mm; with this size, some soil fauna cannot penetrate (Magde 1969). Forty eight bags of 20 × 15 cm size were used (Larwanou 1994). The fresh biomass of *P. africana* and *E. africana* was collected at ICRISAT Research Station on trees of 10 years of age for *P. africana* and 15 years old for *E. africana* and transported at INRAN laboratory for sun drying during seven days then oven dried at 80 °C for 24 hours to get constant weight. Thirty grams of dry biomass were put in each bag. Twenty four bags of dry biomass of each species were deposited under natural conditions for decomposition. The bags were laid in blocks and tied to a stick to immobilize.

Biomass transfer on millet plots

Fresh biomass of the two species was applied on millet plots at N'Dounga. The experimental design was a factorial with 2 factors (species at two levels and fertilization at 4 levels: F1 = control; F2 = 1.5 t ha⁻¹; F3 = 2.5 t ha⁻¹ and F4 = 5 t ha⁻¹) in a complete randomized block with 3 replications. The total number of treatments per block was: 2 species × 4 levels of fertilization making 8 treatments. Each plot has 6 m × 5 m (30 m²). Treatments were separated by 1 m alley and blocks 2 m alley. The millet was sown in July with a spacing of 1m × 1m and biomass is applied two weeks later. Biomass was spread to the corresponding plot and buried immediately to avoid wind dispersal. The litter bags were deposited the day the biomass was applied to millet plots. The treatments were allocated by using STATITCF software.

Data collection

Leaf litter decomposition

Three bags were taken in each batch for initial nutrient elements analysis in the laboratory. Every 14 days, three bags were randomly taken in each batch and brought to the laboratory for oven drying during 24 hours. Soil particles were carefully removed before weighing to determine lost mass. Then, the content of the three bags for each species were mixed and a sample was taken to the laboratory for nutrient elements analysis. Several methods were used to determine the loss of weight of the biomass or decomposition speed. The average quantity of litter accumulated on the ground is also used for determining decomposition speed (UNESCO and ORSTOM 1983).

The ratio of the average weight of litter on the ground with the quantity brought annually is sometimes regarded as an estimate of the average time of disappearance of the litter (in year); although this is not strictly exact, in particular when the litter fall is periodic (Olson 1963). The decomposition over a time shorter than the year according to UNESCO and ORSTOM (1983) was calculated as follows:

$$\begin{aligned} \text{Decomposition (T}_{1,2}) &= \text{litter on the soil (T}_1) \\ &+ \text{contribution of litter (T}_{1,2}) \\ &- \text{litter on the soil (T}_2) \end{aligned}$$

Where T₁ and T₂ are two consecutive observations (generally with intervals of less than 15 days)

Another method consists in observing the same material at various periods. The usual technique consists in placing the bags in-situ with a known weight of biomass. A certain number of bags are taken periodically to determine the quantity of material remaining and to calculate the rate of disappearance (Madge 1969).

The decomposition speeds are expressed in several ways:

Weight of disappeared matter on given soil surface over time unit.

Initial weight of disappeared matter over litter weight over time unit.

Coefficient of decomposition (k) given by decomposed quantity (formula [1]) divided by average quantity of litter on the soil [t₁ + t₂] (Jenny *et al.* 1949; Nye 1961; Olson 1963). The calculation of K is based on the assumption of a decomposition logarithmic curve.

Average time necessary to complete disappearance (or partial).

The litter decomposition speed expressed by $D_s = Fw - Iw/t$ (with D_s : decomposition speed; Fw : final weight; Iw : initial weight and t : duration of decomposition process) is used for the present study.

Millet growth and development parameters

Measurements of the growth parameters on millet (height and number of tillers) were made on six centred individuals in each plot to avoid edge effects. These measurements were taken each week.

At the end of the season, the stems of millet of the six centred individuals were cut off and brought to the laboratory for drying and weighing.

Soil samples

In each block, composite soil samples were collected in three randomly selected different places at depths of 0–10 cm and 10–30 cm. The three samples of each block are mixed according to depths and one sample was taken for chemical and granulometric analysis at the laboratory. For the chemical analysis, the following mineral elements were determined: carbon (C), Nitrogen (N), Phosphorus (P), Sodium (Na), Potassium (K),

Magnesium (Mg) and Calcium (Ca); for granulometric analysis, electric conductivity, clay, silt, fine soils and coarse soils were determined.

Data analysis

The method of Bouyoucos was used to separate soil particles (clay, silt, fine sand and coarse sand). The other elements were analysed with standard chemical analysis methods. Data were analyzed using SPSS (Statistical Package for Social Sciences) software. The descriptive analysis was carried out to show parameters evolution and the variance analysis (GLM), correlation and regression to determine relationships among parameters.

Results

Foliar biomass decomposition

Loss of weight with time

The loss of weight of foliar biomass with time expresses the decomposition speed of a given dry matter mass. The results of this study showed that for the two species, the biomass starts to decompose during the first 4 weeks. The loss of weight observed is more significant for *E. africana* until the twelfth week. After which, the tendency changes in favour of *P. africana* where 49% of the foliar biomass was decomposed against 25% for *E. africana* in 14 weeks (Figure 1).

The decomposition speed for *P. africana* litter is higher than that of *E. africana*. Under the same conditions, foliar biomass of *P. africana* can be completely decomposed in 30 weeks whereas that of *E. africana* in

56 weeks. Thus, the decomposition speed of *P. africana* is higher than that of *E. africana*. This decomposition speed difference could be attributed to the nature of leaves as the environmental conditions are the same.

Chemical elements release by foliar biomass of the two species

Quantity of released nutrient elements and speed of mobility

The mineral elements analysed in *P. africana* litter are: N, P, Na, K, Ca and Mg. The quantities of mineral elements and the release speed are variable. Thus, the quantities of released elements are: Mg (16%), N (18%), Ca (58%), P (10%) and K (21%) in 2, 4, 6 and 12 weeks for P, Na and K; the speed of mobility is established as follows: Mg > N > Ca > P, K. Na has only increased throughout. Almost all the elements underwent this trend on the field. This could explain the increase after the first loss of elements (Table 1). Generally, all the elements underwent a loss at the end of the 14 weeks compared with the initial content except Na.

The percentages and the speed of mobility of mineral elements *E. africana* dry biomass are also variable. The percentages of released elements are: Mg (22%), K (3%), Na (49%), N (32%), P (35%) in 2, 4, 6, 12 (N, P) and 14 (k) weeks. For this species, it has been observed an increase in Ca content. The order of mobility of these elements is thus established: Mg > K > Na > N, P. At the end of 14 weeks, 47% of K was released against 3% in 4 weeks (Table 2).

By comparing the release of the nutrient elements in the litter of the two species, it is clear that Mg is released rapidly for the two species. The quantity of released elements as well as the orders of mobility of

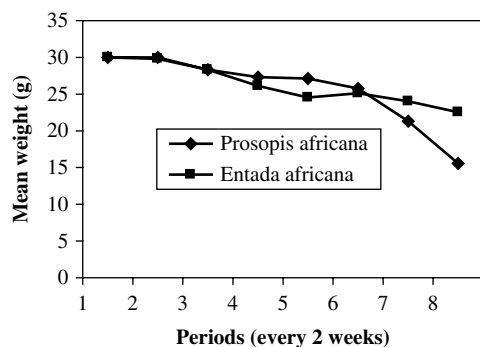

Figure 1. Biomass loss of the two species with time.

Table 1. Mineral nutrients release after *P. africana* dry biomass decomposition

Time (every 2 weeks)	% N	% P	% Na	% K	% Ca	% Mg
0	2.39	16.5	0.23	1.02	5.92	2.58
1	2.35	18.8	0.35	1.06	4.75	2.18
2	1.96	27.2	0.46	2.44	4.05	2.7
3	2.21	30.2	0.46	2.4	2.5	2.8
4	2.37	27.6	0.28	2.24	2.63	2.38
5	2.09	27.5	0.3	2.28	2.88	2.53
6	2.03	14.9	0.23	0.81	3.4	2.25
7	2.32	14.9	0.3	0.9	3.33	2.1

Table 2. Mineral nutrients release after *E. africana* dry biomass decomposition

Time (every 2 weeks)	% N	% P	% Na	% K	% Ca	% Mg
0	3.53	18.5	0.41	1.63	0.38	2.73
1	3.54	17.9	0.46	1.68	3.1	2.1
2	3.01	27	0.23	1.58	2.95	2.43
3	2.91	26.2	0.21	1.88	0.5	2.95
4	3.03	23.3	0.46	1.5	2.83	2.7
5	2.49	23.4	0.46	1.46	3.58	2.23
6	2.41	12	0.35	0.86	3.8	2.5
7	2.95	14.2	0.23	0.86	2.78	2.3

Table 3. Soil chemical characteristics before setting trials

Parameter	Depth(cm)	
	0–10	10–30
Ca (%)	2.9±0.2	3±0.458
Mg%	0.793±0.157	0.886±0.121
Na%	0.031±0.003	0.03±0
K%	0.076±0.006	0.033±0.006
P%	6.456±1.286	2.973±0.547
C%	0.163±0.042	0.153±0.015
N%	0.009±0.004	0.0073±0.006

the other elements differs according to species. Na was not released from the litter of *P. africana* whereas it was in *E. africana*. A similar situation was observed for Ca which was released from *E. africana* whereas it was immobilized in *P. africana* (Tables 1 and 2).

Influence of biomass transfer on soil quality

Basic soil physicochemical characteristics

The soil chemical characteristics before trial set-up i.e. the application of foliar biomass of the two

species were variable with soil depth for all the nutrients elements. Nutrient elements content is more significant at depth 0–10 cm except for C and Mg (Table 3).

The granulometric analysis before foliar biomass application shows that the blocks are statistically different only for one textural element (silt). The statistical analysis for this element shows a significant difference ($p < 0,089$) with 5% of probability for this (Table 3).

With regard to depths, the statistical analysis of the textural elements and electric conductivity show a highly significant difference ($p < 0,001$) for coarse sand with depths where the most significant proportion is observed on soil surface (0–10 cm). The soil granulometric characteristics before trial set-up are as follows: electrical conductivity (0.03 ± 0.01), gley ($8.23 \pm 1.66\%$), limon ($5.97 \pm 2.03\%$), soil small particles ($55.79 \pm 2.01\%$) and soil big particles ($30.02 \pm 1.91\%$).

Soil physicochemical characteristics after decomposition

By comparing Tables 4 and 5 (before and after decomposition of biomass on millet plots), it appears that even after nutrient elements take-up by millet, the soil content of these elements is higher than before decomposition with exception of P. The soil content of this element was seriously reduced compared with its initial content. Even if for the two species, it was observed a release of this element following the biomass decomposition, coupled with the initial soil content, this reduction could explain the fact that millet has taken it much (Table 5). This result shows that millet needs much P for its growth and development; thus, a continuous growing of millet could seriously weaken the soil with this element in arid environment.

Table 4. Soil granulometric characteristics before trial set-up in depth

Depth	Electrical conductivity (EC)			Texture (%)	
	EC	Gley	Limon	Soil Small Particles	Soil Big Particles
1	0.02±0.01	7.57±2.02	5.60±2.94	55.11±1.30	31.72±0.31
2	0.03±0.02	8.88±1.23	6.33±1.13	56.48±2.65	28.31±0.55
Total	0.03±0.01	8.23±1.66	5.97±2.03	55.79±2.01	30.02±1.91

Table 5. Soil chemical characteristics after biomass decomposition

Parameter	Depth (cm)	
	0–10	10–30
Ca (%)	1.333±0.32	1.4166±0.290
Mg%	0.406±0.131	0.453±0.138
Na%	0.036±0.005	0.036±0.005
K%	0.233±0.047	0.053±0.012
P%	2.263±1.549	3.083±1.027
C%	0.21±0.024	0.19±0.029
N%	0.078±0.093	0.010 ±0.002

Influence of foliar biomass transfer on millet development

Influence on millet height

Species and treatments

Foliar biomass application impacts significantly on growth in height of millet according to treatments. For *P. africana*, 2.5 t ha⁻¹ gave good response in millet height. Application of *E. africana* biomass hinders millet growth in height; the response obtained with control is more interesting than all other treatments. Growth in height decreases drastically after 2.5 t ha⁻¹ of *P. africana* biomass application. The same tendency is observed for *E. africana* after 1.5 t ha⁻¹ (Figure 2). For the two species, there is a quantity which should strictly

be respected in order to avoid inhibiting effect in millet growth in height.

Time, species and treatments

Foliar biomass application of the two species according to quantities gives a variable response with time on the growth in height of millet. For *P. africana*, treatment 3 (2.5 t ha⁻¹) gives the best growth in height than all other treatments; it is followed by the control. On the other hand, for the two other treatments (2 and 4), it is observed a deceleration of growth in height until the 4th week. From this date, the height starts to increase. It would be probable that the mineralization of certain elements starts to prevail to reach the minimal threshold of stimulation of this growth in height (Figure 3a).

For *E. africana*, it is noticed a different tendency the treatments with this species show an overall linear growth. Also, the best treatment for the growth in height is treatment 3 (2.5 t/ha) followed by the control. Treatment 2 gives the best response than treatment 4. But all the treatments give a positive response with time. A bending of the curves is observed generally at the 4th week for all treatments, after which, there is a resumption of growth. This period certainly coincides with a phenomenon which causes the deceleration of growth. This phenomenon was corrected thereafter because the normal growth according to treatments took again the normal rate/rhythm (Figure 3b).

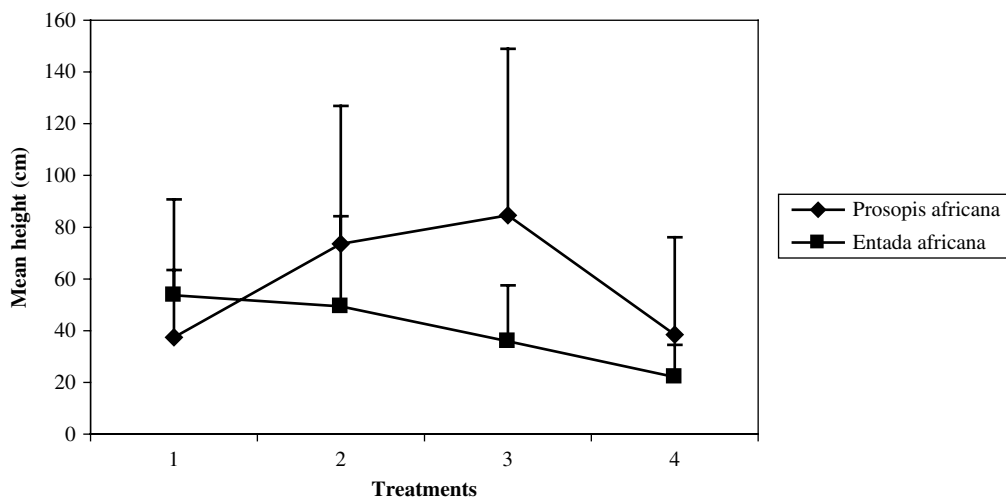

Figure 2. Mean millet height with species treatments.

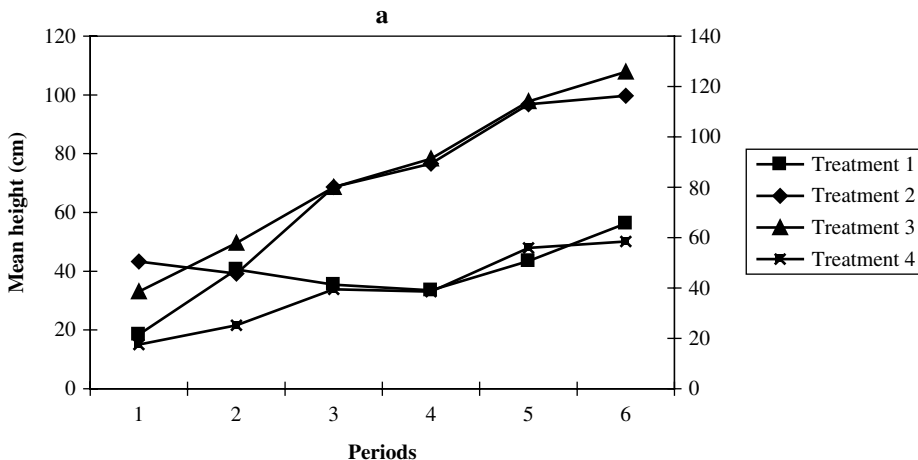

Figure 3a. Response of millet height with time according to treatments with *Prosopis africana*.

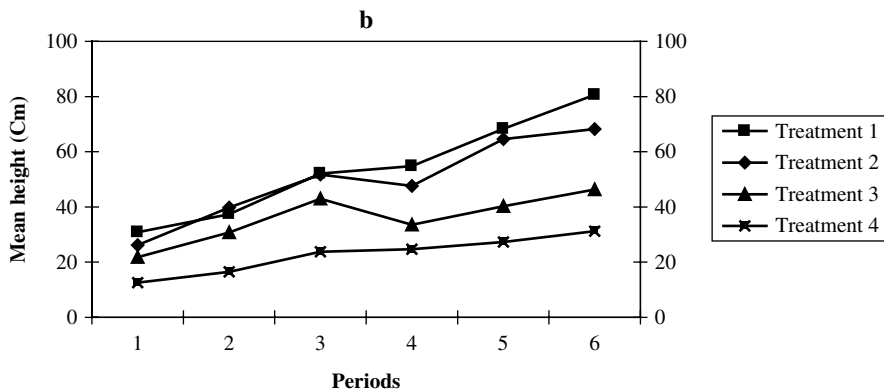

Figure 3b. Response of millet height with time according to treatments with *Entada africana*.

Influence on number of tillers

Species and treatments

Results showed that treatment 2 of all the species gave a mean number of tillers higher than the other treatments, whereas in growth in height, treatment 3 was the best (figure 4).

Time, species and treatments

Foliar biomass application of *P. africana* showed an increase in the number of tillers with time for all the treatments. The peak is reached in the 52nd week except for the control where an increase in the number of tillers

after this period was observed. The curve representing the response from the control took a linear form but below the other treatments. Around the 4th week, a significant response of treatment 4 on the number of tiller was observed. Generally, treatment 2 gave the highest number of tillers than all the other treatments (Figure 5a).

E. africana foliar biomass application started to react positively after the 2nd week on the average number of tillers. Until the 3rd week, even if a response from treatment 4 is observed, the average number of tillers is lower than the control. Treatments 2 and 3 appreciably give the same response in increase in number of tillers with time. In all cases, the response to the application of *E. africana* foliar biomass is more important compared to the control for the number of tillers (Figure 5b).

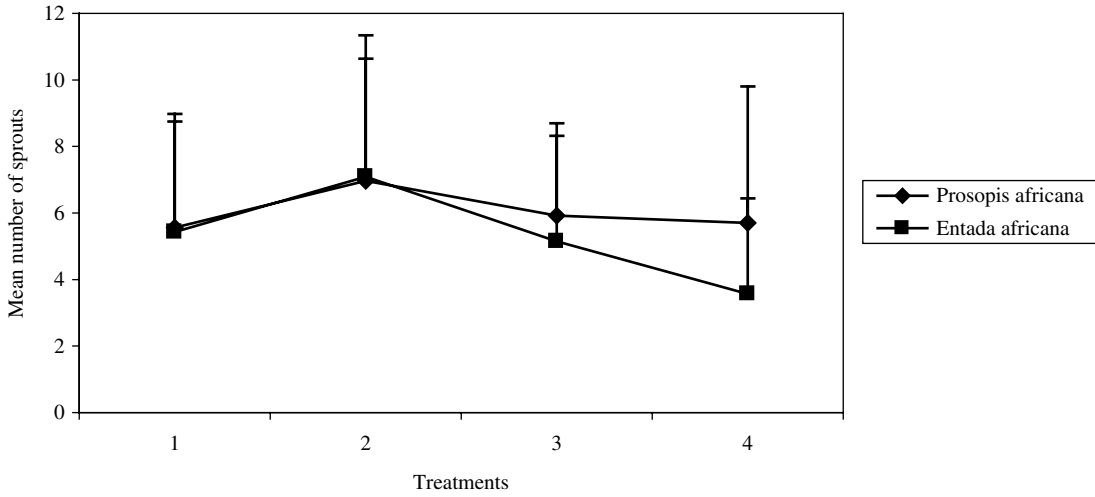

Figure 4. Mean number of new millet sprouts with species treatments.

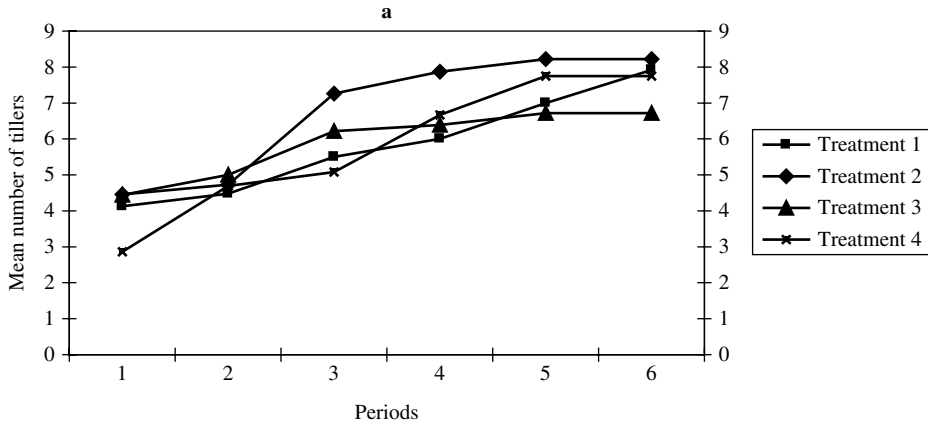

Figure 5a. Response in millet number of tillers with time according to *P. africana* treatment.

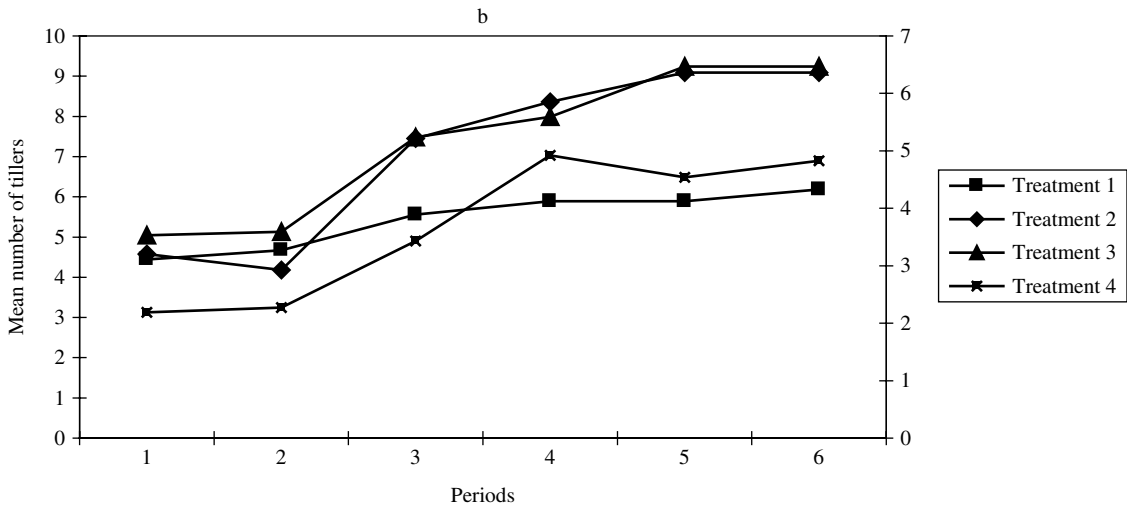

Figure 5b. Response in millet number of tillers with time according to *E. africana* treatment.

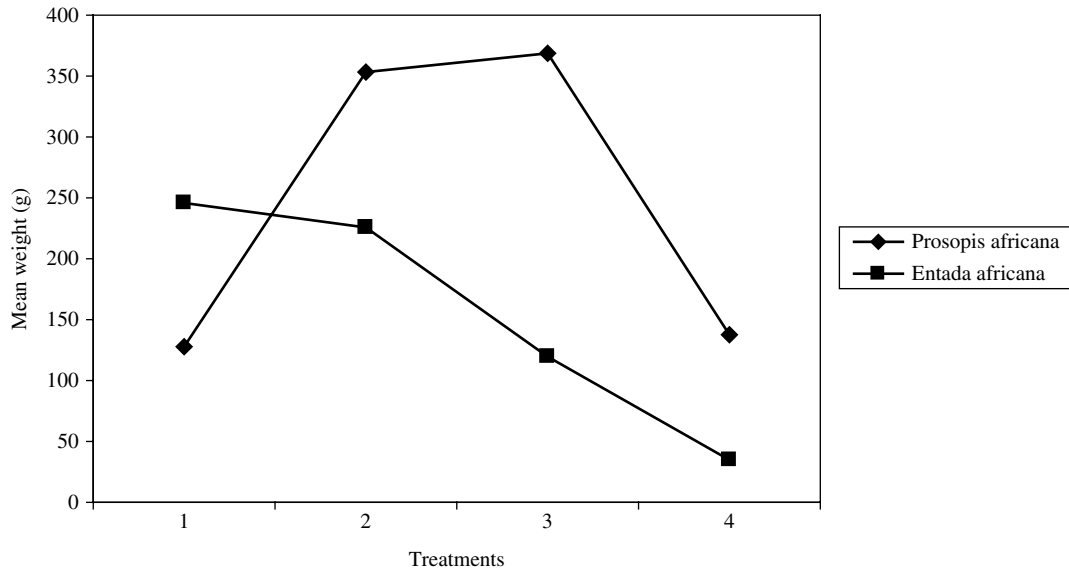

Figure 6. Mean millet straw biomass with time.

Influence on millet straw biomass

Foliar biomass application of *P. africana* gave a millet straws dry biomass production of more than 350 g/plot or 167 t/ha for treatments 2 and 3 (1.5 and 2.5 t/ha of foliar biomass). The smallest quantity of millet straws dry biomass was obtained with treatment 4 below the control treatment. A drastic decrease of millet straws dry biomass production was observed after the control treatment by applying the foliar biomass of *Entada africana*. The production of millet straws dry biomass decreases from the control to treatment 4 (figure 6).

Discussion and conclusion

The foliar biomass of *P. africana* decomposes more rapidly than that of *E. africana* this result confirms former work comparing the decomposition speed of several ligneous species Madge (1965, 1969; Odum and Pigeon (1970); Bernhard-Reversat (1972); Ewel (1976)). Factors related to species could be one of the reasons behind this difference. The trend of dry biomass weight lost observed on the two species with time presupposes that seasonal factor would have played a significant role. In Olokemeji, Hopkins (1966) found that, time of disappearance of the leaves varies

from 1 to 8 months between the rainy season and the dry season and in Omo, it respectively varies from 3–4 months to 6–7 months.

Comparable results concerning foliar biomass lost were found by Madge (1965; 1969) in Nigeria and by Odum and Pigeon (1970) at El Verde.

These results showed the existence of a relationship between precipitations and dry biomass decomposition. Rainfall indirectly controls decomposition while acting on the soil fauna and other micro-organisms. Several authors showed the existence of a relationship between abundance of fauna and precipitation (Madge 1965; Bernhard 1970, Bernhard-Reversat 1972, Golley et al, 1975). As for nutrient elements release and their speed of mobility, the results showed that certain elements are released more rapidly and this phenomenon is variable according to species. Attiwil (1968) in a study on the foliar biomass decomposition of *Eucalyptus deglupta* gave the order of mobility of the elements: Na > K > Ca > Mg > P. Yamoah et al. (1986) observed in 120 days that *Gliricidia* released 71% of total nitrogen needed by corn, *Flemingia*, 26% and *Cassia* 77%. Larwanou (1994) in a study on *Prosopis africana* leaf litter decomposition established the order of nutrient mobility as: K > Ca > P > Mg > N. The same author found that *P. africana* leaves decompose rapidly. More than 50% of macronutrients were released in less than six weeks, given a good response in growth of associated crop.

Biomass transfer as green manure could improve soil fertility and consequently the growth and development of millet. According to Nyanthi et al. (2003), Mafongoya et al. (2003), Horn and Montagnini (1999) nitrogen fixing trees were used biomass transfer on associated crops. These authors also thought that there is a balance between the release of nutrients by litter and the associated crops in biomass transfer system. Kang et al. (1990) showed that on sandy soils with *Leuceana leucocephala*, corn production could be maintained around 2t ha⁻¹ and a significant straws production against 0.66t ha⁻¹ in grain in absence of any fertilization.

Foliar biomass transfer as green manure could have increased growth in height of millet and the significant production in millet straws biomass. Kang and Mulongoy (1992), Kang et al. (1990), Fedden (1998) reported that 30% of requirement in nitrogen for associated crops could be satisfied by pruning nitrogen fixing trees used in alley cropping.

This study has demonstrated the potentials of these two species to improve soil fertility in an arid environment and consequently the growth and development of millet. However, investigation could continue in order to determine relationship between foliar biomass decomposition and the initial content of mineral elements (Bernhard-Reversat 1972; Ewel 1976), which is not yet clearly defined.

References

- Baumer M. 1987. Agroforesterie et désertification, Belgique, ICRAF, Centre Technique de Coopération Agricole et Rurale (CTA), 253 p + annexes.
- Bernard C. 1996. Etude d'un parc à *Prosopis africana* au Nord-Cameroun : cas du village de Holom, en pays Musey (premiers résultats), IRAD-Projet Garoua II-CIRAD-Forêt-ORSTOM-CIRAF, 141 p.
- Bernhard F. 1970. Etude de la litière et de sa contribution au cycle des éléments minéraux en forêt ombrophile de Côte d'Ivoire. *Ecologia Plant* 7: 279–300.
- Bernhard-Reversat F. 1972. Décomposition de la litière de feuille en forêt ombrophile de basse Côte d'Ivoire. *Ecologia Plant* 7: 279–300.
- Ewel J.J. 1976. Litter fall and leaf decomposition in a tropical forest succession in Eastern Guatemala. *Journal Ecologia* 64: 293–308.
- Fedden M. 1998. Forest form husbandry, Kumassi (Ghana), Technology Consultancy Center, Un. Science and Technology, 73 p.
- Golley F., Ginnis J.T.M., Clements R.G., Child G.I. and Duever M.J. 1975. Mineral cycling in a tropical moist forest ecosystem, Athen, University of Georgia Press, 248 p.
- Gros A. 1967. Engrais guide pratique de la fertilisation, Paris, 5^e édition, 342 p.
- Hopkins B. 1966. Vegetation of the Olokeneji: forest reserve, Nigeria. The litter and soil with special reference to their seasonal changes; *Journal Ecologia* 54: 687–703.
- Horn N. and Montagnini F. 1999. Litterfall, litter decomposition and maize biomass of mulches from four indigenous tree species in mixed and monospecific plantations in Costa Rica. *International Tree Crops Journal* 10 (1): 37–50.
- Iktam A. and Kho R. 1996. Rapport d'activités 1996: Département de Recherches Forestières (DRF), INRAN, 40 p.
- Janssen B.H. 1993. Gestion intégrée de la fertilisation: l'emploi des engrais organiques et minéraux. In: Reuler H.V. and Prins W.H. (eds) Rôle de la fertilisation pour assurer une production durable des cultures vivrières en Afrique Sub-saharienne, Pays-Bas, The Dutch Association of Fertilizer Producers, pp 99–116.
- Jenny, H., Gessel, S.P. & Bingham, F.T. 1949. Comparative study of decomposition rates of organic matter in temperate and tropical regions. *Soil Sci.* 68: 419–432.
- Kang B.T., Reynolds A.N. and Atta K. 1990. Alley farming; *Agron.* 43: 315–359.
- Kang B.T. and Mulongoy K. 1992. Nitrogen contribution of woody legumes in alley cropping systems. In: Mulongoy K., Gueye M. and Spencer D.S.C. (eds) Biological nitrogen fixation and sustainability of tropical agriculture, pp 367–375.
- Kanté S. 2001. Gestion de la fertilité des sols par classe d'exploitation au Mali-Sud, Pays Bas, Document sur la Gestion des Ressources Tropicales 38 : 225 p.
- Laudelout H. and Meyer J. 1954. Les cycles d'éléments minéraux et de matière organique en forêt équatoriale congolaise. *Soil Science* 2: 267–272.
- Larwanou M. 1994. Potentials of *Prosopis africana* leaf litter for soil nutrient enhancement and crop development, M.Sc. thesis, University of Ibadan, 72p.
- Madge D.S. 1965. Leaf fall and litter disappearance in a tropical forest. *Pedobiologia* 5: 273–288.
- Madge D.S. 1969. Field and laboratory studies on the activity of two species of tropical earthworms. *Pedobiologia* 9: 188–214.
- Mainguet M. 1995. L'homme et la sécheresse, Paris, Masson, Collection Géographie, 335 p.
- Mafongoya P.L., Mugendi D.N., Jama B. and Waswa B.S. 2003. Maize-based cropping systems in the subhumid zone of East and Southern Africa. In: Gichuru M.P., Bationo A., Bekunda M.A., Goma H.C., Mafongoya P.L., Mugendi D.N., Murwira H.M., Nandwa S.M., Nyathi P. and Swift M.J. (eds). Soil fertility management in Africa: A regional perspective, Nairobi, CIAT, TSBF, CTA, DANIDA, 306 p.
- Mann, H.S. & Saxena, S.K., eds. 1980. *Khejri* (*Prosopiscineraria*) in the Indian desert – its role in agroforestry. CAZRI Monograph No. 11. Jodhpur, Inde, CAZRI. 93p.
- Nyati P., Kimani S.K., Jama B., Mapfumo P., Murwira H.K., Okalebo J.R. and Bationo A. 2003. Soil fertility management in semi arid areas of East and Southern Africa. In: Gichuru M.P., Bationo A., Bekunda M.A., Goma H.C., Mafongoya P.L., Mugendi D.N., Murwira H.M., Nandwa S.M., Nyathi P. and Swift M.J. (eds). Soil fertility management in Africa: A regional perspective, Nairobi, CIAT, TSBF, CTA, DANIDA, 306 p.
- Nye P.H. 1961. Organic matter and nutrient cycles under moist tropical forest; *Plant and soil*, 13(4): 333–346.

- Odum H.T. and Pigeon R.F. 1970. A tropical rain forest. A study of irradiation and ecology information, USAEC (Union Scientific Atomic Energy Commission), Oakridge Tennessi, 1678 p.
- Olson J.S. 1963. Energy storage and the balance of producers and decomposers in ecological system. *Ecology* 44: 322–331.
- Soumeylou A. 1996. Session de recyclage/formation continue en agroforesterie pour ingénieurs forestiers, document de cours, Tabakoro 13–18 mai 1996, 32 p.
- UNESCO/ORSTOM. 1983. Ecosystèmes forestiers tropicaux d’Afrique, Paris, ORSTOM (Office de la Recherche scientifique et Technique d’Outre-mer), recherches sur les Ressources Naturelles, XIX, 473 p.
- Vandenbeldt R.J. and Renard C. 1991. *Faidherbia albida* dans les zones semi-arides d’Afrique de l’Ouest, comptes rendus d’un atelier tenu du 22–26 avril 1991, Niamey, ICRISAT, 206 p.
- Wood P.J. and Burley J. 1993. Les arbres à usages multiples: Introduction et évaluation pour l’agroforesterie, Nairobi, ICRAF (Centre international pour la recherche en agroforesterie), 5^e édition, 141 p.
- Yamoah C.F., Agboola A.A. and Mulongoy K. 1986. Decomposition, nitrogen release and weed control by prunings of selected alley cropping shrubs; *Agroforestry Systems* 4: 239–246.

Soil microbial biomass carbon and nitrogen as influenced by organic and inorganic inputs at Kabete, Kenya

¹Baaru M.W.*, ¹Mungendi D.N., ²Bationo A., ³Verchot L., ¹Waceke W.

¹Environmental Foundation, Kenyatta University, P.O. Box 43844, Nairobi, Kenya; ²Tropical Soil Biology and Fertility (TSBF), Institute of CIAT P.O. Box 30677, Nairobi, Kenya; ³International Centre for Research and Agro forestry P.O. Box 30677, Nairobi, Kenya, *Correspondence author: baaruwamuyu@yahoo.com

Abstract

Soil microbial biomass is the main driving force in the decomposition of organic materials and is frequently used as an early indicator of changes in soil properties resulting from soil management and environment stresses in agricultural ecosystems. This study was designed to assess the effects of organic and inorganic inputs on soil microbial biomass carbon and nitrogen overtime at Kabete, Kenya. *Tithonia diversifolia*, *Cassia spectabilis*, *Calliandra calothyrsus* were applied as organic resources, and Urea as inorganic source. Soil was sampled at 0–10 cm depth before incorporating the inputs and every two months thereafter and at harvesting in a maize-cropping season. Soil microbial biomass carbon and nitrogen was determined by Fumigation Extraction method (FE) while carbon evolution was measured by Fumigation Incubation (FI) method. The results indicated a general increase in soil microbial biomass carbon and nitrogen in the season with the control recording lower values than all the treatments. Microbial biomass carbon, nitrogen and carbon dioxide evolution was affected by both quality of the inputs added and the time of plant growth. *Tithonia* recorded relatively higher values of microbial biomass carbon, nitrogen and carbon evolution than all the other treatments. A significant difference was recorded between the control and the organically treated soils at the end of the season for the microbial biomass nitrogen and carbon dioxide evolution. Both the microbial biomass C and N showed a significant difference ($P \leq 0.05$) in the different months of the season.

Key words: microbial biomass carbon, microbial biomass nitrogen, Carbon evolution, chloroform fumigation extraction method

Introduction

Microbes constitute about one quarter of all living biomass on earth and are responsible for significant nutrient transformations involving both macro and micro nutrients (Alexander 1977) and therefore influencing nutrient availability and ultimately soil health and quality. Soil microbial biomass is the main driving force in the decomposition of organic materials and is frequently used as an early indicator of changes in soil chemical and physical properties resulting from soil management and environment stresses in

agricultural ecosystems (Brookes 1995; Jordan et al. 1995; Transar-capeda et al. 1998). Though 1–3% of total soil C and 5% total soil N is soil microbial biomass C and N respectively, they are the most labile pools in soils (Jenkinson and Ladd 1981) and therefore the nutrient availability and productivity of agro ecosystems mainly depends on the size and activity of the microbial biomass (Friedel et al. 1996). Turn over of microbial biomass is a dynamic process, and responds relatively quickly to changes in environmental conditions, i.e., climate, input of nutrients, and disturbance. In undisturbed ecosystems, nutrient cycles tend to be

more closed and less “leaky” than agro ecosystems. However, an important characteristic of agro ecosystems is that they export large inputs, in the crop biomass and, therefore, addition of large amounts of organic materials to replenish the soils is needed. Sustainable agro ecosystems will probably require more and better-informed management of all ecosystems components including soil biota. The determination of microbial biomass provides estimates of the net flux of carbon and nitrogen through microbial pools and thus reflects the contribution of soil microorganisms as both a source and a sink of carbon and nitrogen in soil ecosystems. Several authors have reported the identification of biological indicators of soil quality as critically important (Doran and Parkin 1994; Elliott et al. 1996), and the rationale for the use of microbial and biochemical parameters as soil fertility indicators is their central role in the cycling of C and N (Visser and Parkison 1992) and their sensitivity to change (Brookes 1995). With the addition of organic waste into the soil becoming a wide spread practice, due to the fact that they are a source of nutrients (Perucci et al. 2000), their effects on soil microbial biomass (SMB) should be taken into account. However, the role of macro and microorganisms in soil productivity, especially transformations and availability of nutrients remains to be fully understood (Zhenli et al. 2003). Because soil microorganisms carry out many below ground process, estimates of microbial biomass may be useful for comparisons of ecosystems function of sites with similar climate, geology, and land use histories. This study was therefore set to evaluate the effects of organic and inorganic resources on soil microbial biomass carbon and nitrogen.

Materials and methods

Study site and experimental design

This experiment was carried out at the National Agricultural Research laboratories (NARL), at Kabete station (36° 46' E – 01° 15' S, 1,650 m asl). The climate is sub-humid, with annual rainfall bi-modal falling in two distinct seasons: the long rainy season (mid March to June) and the short rainy season (mid October to December). Average rainfall is 937 mm. The soils are trachyte geological material typically Humic Nitosols (according to FAO, UNESCO), deep and well weathered and with moderate amounts of carbon (C), calcium (Ca), magnesium (Mg), and potassium (K),

but low available phosphorus (P). The experiment was a Randomized Complete Randomised Block Design (RCBD) with 10 treatments replicated four times. In the study, five treatments were considered as Control, Fertilizer, *Tithonia diversifolia*, *Senna spectabilis* and *Calliandra calothyrsus*. Organic inputs were broadcasted and incorporated before planting as fresh leaves. They were applied on dry matter basis in order to obtain 60 kg N/ha applied, whereas urea was split in two applications (at planting and five weeks after) to give a rate of 60 N kg/ha. Organic materials were chosen to reflect contrasting amount of lignin, polyphenols and the rate of decomposition of each which has been summarized as calliandra (14.4%, 11.1%), senna (10.9%, 2.6%) and tithonia (5.2%, 2.2%) respectively (Mutuo et al. 1999; Lehmann et al. 1999). The rate of decomposition has also been observed to follow the sequence tithonia > senna > calliandra (Palm et al. 2001). Maize (*Zea mays*) was used as test crop and was planted at 0.75 × 0.25 m between and within rows respectively in each of the 5 plots measuring 5.25 m by 5 m.

Soil sampling

Soil samples were collected at planting (before incorporating materials), every two months within the season and at harvesting. 5 cores samples were collected at 0–10 cm depth, pooled together, mixed thoroughly and sieved to remove stones, plant debris and soil fauna. The samples were placed in polythene papers and transported to the laboratory for analysis. In the laboratory, the soil samples were stored at 4°C prior to analysis. The water holding capacity of each sample was determined and the moisture content adjusted to 45% for microbial analysis. The samples were then incubated at 25°C for 7 days in the dark to permit uniform rewetting and allow microbial activity to equilibrate after initial disturbances.

Laboratory analysis

All laboratory analysis was done as described in the laboratory methods of soil and plant analysis (ICRAF 1995; Anderson and Ingram 1993). Soil sub samples (25g equivalent dry weight) were weighed in duplicates for fumigation extraction (FE) and fumigation and incubation (FI) (Jenkinson and Powlson 1976a, b). Fumigation was done by placing soil sub samples in

desiccators with ethanol-free chloroform for 24 hrs in a darkroom. Fumigated samples were removed after evacuating the desiccators using a vacuum pump to free off the chloroform. Microbial biomass carbon and nitrogen was determined after fumigation by the FE. Fumigation incubation method was carried out after soil fumigation. This was done by adding 1 g of fresh soil to 25 g of the fumigated soil. It is expected that the microorganisms in the fresh soil will utilize the killed cells as substrate and therefore grow vigorously releasing a lot of carbon dioxide. Incubation was done by placing fumigated and inoculated soils in to a 250 ml jar with the bottom lined up with 10 ml of water and containing 10 ml of 1N NaOH in a separate small glass vial. The jars were then air-tightened and incubated for 10 days. A second set of unfumigated soil was incubated in the same way. Carbon evolution was determined after the incubation.

Microbial biomass Carbon and Nitrogen

Microbial biomass was determined by extracting fumigated and unfumigated soils with 0.5M K₂SO₄ after shaking on an orbital shaker at 150 rpm for 1 hour. Microbial biomass C was analysed by dichromate method while microbial biomass N was determined using the salicylic method. Microbial C & N were calculated as follows Microbial C = C_(fumigated) – C_(non-fumigated)

$$\text{Microbial N} = \text{N}_{(\text{fumigated})} - \text{N}_{(\text{non-fumigated})}$$

Carbon dioxide evolution

Carbon dioxide evolution was estimated by measuring CO₂ respired from the soil over a period of 10 days. The CO₂ trapped in 1N NaOH was analysed by back titration with 1N HCL after addition of excess 3N BaCl₂. The amount of CO₂ respired from fumigated and unfumigated was used to calculate soil microbial biomass in the equation:

$$\text{Biomass C} = (\text{F}_c - \text{Uf}_c)/\text{k}_c$$

Where

F_c = CO₂ flush from the fumigated sample

Uf_c = CO₂ produced by the control

k_c = Constant

Data analysis

Data was analyzed using analysis of variance (ANOVA) with Genstat 6 for Windows (Release 4.1). Least significance difference was used at 0.05-probability level to detect significant differences among treatments.

Results

Microbial biomass carbon

Control gave lowest values of microbial biomass carbon over the season as compared to the treated soils (Table 1). Among the sole organic treatments, calliandra was highest followed by senna and Tithonia treatments respectively (Table 1). However, there was no significant difference (P < 0.05) recorded among the treatments. Microbial biomass recorded across the months in the season was found to be significantly differently. An increase of about 140.4% in microbial biomass carbon was recorded eight weeks after input application (Table 1), which coincides with the peak plant growth. Microbial biomass carbon decreased within the season reaching its lowest level at the end of the season.

Microbial biomass nitrogen

The control treatment gave the lowest level of microbial biomass nitrogen (Table 2), implying an increase with input addition. Among the organically treated soils, calliandra recorded the lowest level of microbial biomass nitrogen over the season. However, the sequence was not consistent. Tithonia gave the highest values of microbial biomass nitrogen eight weeks after inputs application while senna treatment recorded highest at

Table 1. Microbial biomass nitrogen values in mg N kg⁻¹ of soil

Sampling month	April	June	August	October
<i>Treatment</i>				
Control	25.63	15.93	1.97	6.42
Tithonia	35.00	26.20	3.18	15.65
Fertilizer	37.13	25.13	2.55	13.49
Senna	29.50	22.40	5.27	18.78
Calliandra	27.00	21.82	2.57	13.49
SED	11.28	6.97	1.28	1.68
P ≤ 0.05	0.53	0.06	0.19	0.01

Table 2. Microbial biomass Carbon values in mg C kg⁻¹ of soil

Sampling month	April	June	August	October
<i>Treatment</i>				
Control	85.06	226.68	121.99	45.29
Tithonia	111.40	260.10	126.11	47.79
Fertilizer	114.76	253.42	126.65	46.86
Senna	107.61	265.90	130.55	48.27
Calliandra	116.68	273.30	147.33	50.50
SED	33.00	24.67	21.61	18.91
P ≤ 0.05	0.86	0.30	0.35	0.53

16 weeks and at the end of the season (Table 2). At the end of the season, control treatment was found to be significantly ($P \leq 0.05$) lower than all the other treatments (Table 2). Fertilizer and calliandra treatments were also found to be significantly lower than Senna. A decrease in microbial biomass nitrogen was observed eight weeks after input addition, which continued to 16 weeks within the season and coincided with the peak of plant growth.

Cumulative carbon dioxide evolution

Carbon dioxide evolved by the organically amended soils was found to be higher than that recorded for the control and fertilizer throughout the season (Table 3). Tithonia gave significantly ($P \leq 0.05$) higher values of carbon dioxide than fertilizer and control treatments at the end of the season. Among the organically treated soils, calliandra tended to evolve the least carbon dioxide compared to senna and tithonia treatments (Table 3). Evolved carbon dioxide decreased with time reaching a minimum eight weeks after addition. At the end of season, an increase in CO₂ evolution was observed across all treatments except for calliandra 100% (Table 3).

Table 3. Carbon dioxide evolution.

Sampling month	April	June	August	October
<i>Treatment</i>				
Control	163.12	82.13	101.23	111.23
Tithonia	243.06	189.43	221.23	299.35
Fertilizer	177.03	142.08	103.05	111.09
Senna	271.15	172.06	230.09	260.15
Calliandra	295.09	125.43	187.19	170.28
SED	80.30	54.20	44.41	81.30
P ≤ 40.05	0.60	0.13	0.63	0.03

Discussion

The results suggest that addition of organic inputs increase soil microbial biomass as compared to control and fertilizer treatments and that the size of the microbial biomass is dependent on the type of organic material added. For example, we found higher values of microbial biomass carbon for organically treated soils as opposed to either control or fertilizer. Similar results were reported by Leita et al. (1999), Smith et al. (1993) and Tunlid and White (1982). The sequence of microbial biomass carbon among the organic inputs was calliandra < senna < tithonia. This trend can be attributed to the difference in decomposition rate among the organic materials. Tithonia has been shown to decompose rapidly as compared to senna and calliandra (Gachengo et al. 1999) due to the low level of lignin and polyphenols in the leaves, therefore readily providing food for microbial growth. Recorded increase in microbial biomass carbon eight weeks after addition of inputs can be attributed to the readily available carbon for microbial growth. This also coincided with the peak of plant growth suggesting that plant growth stimulates microbial biomass carbon. The results concurs with the findings of Kaiser and Heinemeyer (1993), Fraser et al. (1988), Mc Gill et al. (1986) and Lynch and Panting (1982), that crop growth often stimulates an increase in the size of microbial biomass during growing season.

The findings of microbial biomass nitrogen indicate that addition of inputs increases the size of nitrogen biomass in the soil. However, this depended on the type of the input and stage of plant. The high levels of microbial biomass nitrogen recorded with tithonia treatment could be attributed to its faster release of nitrogen as compared to senna and calliandra treatments. The decrease in microbial biomass nitrogen coincided with the peak of plant growth (8 to 16 weeks after input addition). Competition for mineral nitrogen by plants and microbes in the soil has been reported (Kaye and Hart 1997; Schimel et al. 1989). This decrease can be explained by the peak demand for nitrogen and therefore presenting a competitive nature between plants and the microbes.

The data on carbon dioxide evolution indicate that addition of organic inputs increase microbial activity or microbial biomass. Carbon dioxide evolution also seems to depend on the material added. Among the organic inputs calliandra gave the lowest value of carbon dioxide and this implies that not only the amount of organic resources added to the soil affect

carbon evolution but also the quality. Possible explanation for this could be the slow decomposition rate for calliandra. The higher carbon dioxide evolved for tithonia can be related to its higher decomposition rate and therefore releasing nutrients for microbial growth faster than the other organic resources. The decrease in carbon evolution recorded eight weeks after input application could present a less stressed microbial biomass, as a pool of carbon is available from the added inputs.

Conclusion

Soil microorganisms are very important for nutrient transfer in low input systems, where crops largely depend on nutrient release from organic materials rather than from inorganic fertilizers. Addition of organic materials was found to boost microbial biomass, which would mean that nutrients were made readily available plant than in the unamended soils. Microbial biomass was greatly influenced by the quality of the organic inputs and time. However, no significance difference was among the treated soils, which would be attributed to the quantity of organic material, added. This calls for more research on microbial biomass under different application rates and since microbial biomass is very dynamic, it would also be important to consider sampling for shorter periods within the season and for more seasons.

Acknowledgement

We wish to thank Rockefeller Foundation for the financial support for this study through the African network for Soil biology and fertility (AfNet-TSBF).

References

- Anderson J.M. and Ingram J.S.L. 1993. *Tropical Soil Biology and Fertility: a handbook of methods*. CAB International, Wallingford, U.K.
- Alexander M. 1977. *Introduction to soil microbiology* (2nd edn). New York, Wiley.
- Brookes P.C. 1995. The use of microbial parameters in monitoring soil pollution by heavy metals. *Biol. Fertil. Soils* 19:269–279.
- Doran J.W. and Parkin T.B. 1994. Defining and assessing soil quality. In: Doran J.W. Coleman D.C., Bezdicek D.F. and Stewart B.A. (Eds) *Defining soil quality for a sustainable environment*. SSSA special publication No. 35. Madison, Wis. 3–21.
- Elliott L.F., Lynch J.M., Papendick R.I. (1996). The microbial component of soil. Quality. In: Startzky G. Bollag J.M. (ed). *Soil Biochemistry*, Vol 9. Dekker, New York, pp. 1–21.
- Friedel J.K., Munch J.C., Fischer W.R. (1996). Soil microbial properties and the assessment of available soil organic matter in a crop rotation. *Soil Bio Biochem* 28:479–488.
- Fraser D.G., Doran J.W., Saha W.W., Lesoing G.W. (1988). Soil microbial biomass populations and activities under conventional and organic management. *Journal. Environ. Qual.* 17:585–590.
- Gachengo C.N., Palm C.A., Jama B. and Othieno C. 1999. Tithonia and senna green manures and inorganic fertilizers as phosphorous sources for maize in western Kenya.
- ICRAF 1995. *Laboratory methods for Soil and Plant analysis*. Version 1.1. Nairobi.
- Jenkinson D.S. and Powlson D.S. 1976a. The effects of biocidal treatment on metabolism in soil.
- Jenkinson D.S. and Powlson D.S. 1976b. The effects of biocidal treatment on metabolism in soil. V. A method for measuring soil biomass. *Soil Biol. Biochem.* 8:209–213.
- Jenkinson D.S. and Ladd J.N. 1981. Microbial biomass in soil: measurement and turnover. In: Paul E.A. and Ladd J.N. (Eds) *soil biochemistry*, vol. 5. Dekker, New York, 415–471.
- Jordan D., Kremer R.J., Bergfield W.A., Kim K.Y. and Cacio V.N. 1995. Evaluation of microbial methods as potential indicators of soil quality in historical agricultural fields. *Biol. Fertil. Soils* 19:297–302.
- Kaiser E.A. and Heinemeyer O. 1993. Seasonal variations of soil microbial biomass carbon within plough layer. *Soil Biol. Biochem.* 25:1649–1655.
- Kaye J.P. and Hart S.C. 1997. Competition for nitrogen between plants and soil microorganisms. *Tress*: 139–143.
- Leita L., De Nobili M., Mondini C., Muhlbachova G., Marchiol L., Bragato G. and Contin M. 1999. Influence of organic and inorganic fertilization on soil microbial biomass, metabolic quotient and heavy metal bioavailability. *Biol. Fertil. Soils* 28: 371–376.
- Lynch J.M. and Panting L.M. 1982. Effects of season, cultivation and nitrogen.
- Mutuo P.K., Marandu A.E., Rabeson R., Mwale M., Snapp S. and Palm C.A. 1999. Nitrogen fertilizer equivalences based on organic input quality and optimum combinations of organics and inorganic N sources: Network trial results from East and Southern Africa. SWNM Report on the combating Nutrient Depletion. East Africa Highlands Consortium.
- Mc Gill W.B., Cannon K.R., Robertson J.A. and Cook F.D. 1986. Dynamic of soil microbial biomass and water soluble organic C in Breton L. after 50 years of cropping to two rotations. *Can J Soil Sci* 66:1–9.
- Palm C.A., Gachengo C.N., Delle R.J.M., Cadisch G. and Giller K.E. 2001. Organic inputs for soil fertility management in tropical agroecosystems: application of an organic resource database. *Agric. Ecosyst. Environ.* 83:27–42.
- Perucci P., Dumont S., Bufo S.A., Masseur A. and Caducei C. (2000). Effects of organic amendment and herbicide treatment on microbial biomass. *Biology and Fertility soils* 32:17–23.
- Schimel J.P., Jackson L.E. and Firestone M.K. 1989. Spatial and temporal effects on plant-microbial competition for inorganic nitrogen in California annual grassland. *Soil Biol. Biochem.* 21: 1059–1066.

- Trasar-Capeda C., Leiros C., Gil-sotres F. and Seoane S. 1998. Towards a biochemical quality index for soils: an expression relating several biological and biochemical properties. *Biol. Fertil. Soils* 26:100–106.
- Tunlid A. and White D. 1992. Biochemical analysis of biomass, community structure, nutritional status, and metabolic activity of microbial communities in soil. 229–262. In: Stotzky G. and Bollag J. (eds) *J Environ, Quality* 29, Soil Biochemistry, vol. 7. Marcel Dekker.
- Visser S. and Parkison D. 1992. Soil biological criteria as indicators of soil quality; soil microorganisms. *Am J. Altern. Agric.* 7: 33–37.
- Zhenli H., Yang X.E., Baligar V.C. and Calvert D.V. 2003. Microbiological and Biochemical in indexing systems for assessing quality of acid soils. *Advances in Agronomy*, 78: 90–129.

Evaluating effect of mixtures of organic resources on nutrient release patterns and uptake by maize

F.O. Ayuke^{1,4}, N.K. Karanja^{2*}, S.W. Bunyasi³

¹Service Department for Humanities, Social Studies, Pure and Applied Sciences, Kenya Methodist University, P.O Box 267, Meru Kenya; ²Department of Land Resource Management and Agricultural Technology, College of Agriculture and Veterinary Sciences, University of Nairobi, P.O Box 30197, Nairobi, Kenya; ³Coffee Research Foundation (CRF), Sagana, Kenya; ⁴Department of Soil Quality, Wageningen University, P.O Box 8005, 7600 EC Wageningen, The Netherlands. *Corresponding author: nancy.karanja@cgiar.org

Abstract

To supplement high costs of inorganic fertilizers, smallholder farmers in the tropics are likely to increase the use of appropriate plant residues as an alternative source of plant nutrients especially nitrogen (N) and phosphorus (P). To maximize benefit accrued from these materials, synchronizing nutrient release patterns of the materials with crop's nutrient requirements need to be understood. Consequently, this study was undertaken to: (1) evaluate the effect of plant residues on mineralization and N-release patterns, (2) evaluate the N release patterns of mixtures of low and high quality organic materials and synchrony with maize uptake. Incubation studies were established for 12 weeks using six selected plant residues: which included *Leucaena leucocephala*, *Croton macrostachyus*, *Calliandra calothyrsus*, *Tithonia diversifolia*, *Sorghum bicolor* and rice (*Oryza sativa*) husks. Soil samples were taken at 2 weeks interval for ammonium nitrogen (NH_4^+ -N) and nitrate nitrogen (NO_3^- -N) determination.

The organic residues differed in their chemical composition and this was found to influence mineralization rates and nitrogen release patterns. Two distinctive NO_3^- -N + NH_4^+ -N release patterns were observed over the incubation period. *L. leucocephala*, *C. macrostachyus*, *C. calothyrsus*, *T. diversifolia* had a net N release throughout while *S. bicolor* and rice husks (*O. sativa*) had a significant N immobilization. Nitrogen-release was best correlated with C:N ratio ($r^2 = -0.84$ to -0.90) for most of the sampling periods. Polyphenol:N ratio also had a significantly high correlation with cumulative N mineralized ($r^2 = -0.65$ to -0.95).

Two organic resource with contrasting C:N and PP:N ratios i.e. *C. macrostachyus* and *O. sativa* were selected for use and in depth effect of mixing high quality *C. macrostachyus* (Cm) and low quality *O. sativa* (Os) at different ratios on mineralization N release patterns. Agronomic effectiveness of the best mixture, which was based on N release, was measured using maize as the test crop in a glasshouse experiment. The dynamics of N-mineralization of the various mixture of *C. macrostachyus* (Cm) and *O. sativa* (Os) were in general not significantly different from those predicted from the *O. sativa* and *C. macrostachyus* treatments alone with the exception of the $\frac{3}{4}$ Cm + $\frac{1}{4}$ Os which gave significant N immobilization at 6–8 weeks and the $\frac{1}{4}$ Cm + $\frac{3}{4}$ Os which enhanced N mineralization at 2 and 12 weeks respectively. Addition of plant residues significantly increased maize biomass in the glasshouse with potted mixtures of plant residues giving the highest maize dry matter yield and N uptake

Key words: Agronomic effectiveness, chemical composition, mineralization, nutrient release, nutrient uptake, organic resources

Introduction

Continuous cropping without and/or minimal addition of organic or inorganic fertilizers has resulted in depletion of nitrogen, phosphorus, potassium and

other trace elements in most of the soils found in sub-Saharan Africa (SSA) (ICRAF 1996). Besides, majority of the smallscale farmers are unable to acquire the inorganic fertilizers due to poor infrastructure coupled with their high costs (Niang et al. 1996; Rao et al. 1998).

Application of animal manures which are a recommended alternative to maintaining soil fertility and crop productivity are available in inadequate amounts to be effective in replenishing soil productivity (Bationo and Mokwunye 1991). Farmers have therefore been left with the option of using a variety of low input practices. Numerous studies conducted in the region, have demonstrated that agroforestry technologies such as green-manure (biomass transfer), improved fallows or incorporation of crop residues do result in increased crop yields (Gachengo 1996; Niang et al. 1996; Rao et al. 1998). These organic residues do play an important role in soil fertility management through their short term effects on nutrient supply and coupled with a longer term contribution to soil organic matter (SOM).

Application of organic residues is a common agricultural practice for maintaining soil nutrient levels and ameliorating soil physical properties to sustain crop production (Baldock and Musgrave 1980; Fu et al. 1987). This is more so in many developing countries where fertilizer use is limited by high costs and poor infrastructure (Kang and Wilson 1987; Kang 1988; ICRAF 1996). Plant residues from planted fallows or prunings from hedgerows in alley cropping systems could contribute significant quantities of nutrients to the associated crops (Kang et al. 1981; Mulongoy and Van der Meersch 1988). These resources could also be used to supply plant nutrients to supplement inorganic fertilizers. However, their potential to supply adequate nutrients to crops is dependent on their quality and quantity, management techniques and the soil environment (e.g. moisture, temperature, microbial activity (Myers et al. 1994; Gachengo 1996; Niang et al. 1996; Mafongoya et al. 1998; Rao et al. 1998).

Although organic resources used alone offer insufficient nutrients to sustain crop yields and build on soil fertility (Palm et al. 1997), they do continue to play critical role. Therefore, in low agricultural input systems, the overall challenge is to: identify appropriate indices for use in selecting plant materials that can supply sufficient plant nutrients for crops and develop technologies for managing organic matter decomposition to synchronize nutrient release with crop needs. Manipulation of organic residues by mixing different qualities on nutrient release and synchrony is thought to be one way in which this could be achieved although according to Constantides and Fownes (1994); Mafongoya et al. (1998), interactions in the decomposition of residue mixtures may be complex. This study aimed at: (1) quantifying the chemical composition of various on-farm plant materials, (2) evaluating the effect

of mixing low quality and high quality plant residues on amounts and patterns of mineral N-release, (3) relating crop response to the N-released from various plant residues and their mixtures using maize as a test crop in a glasshouse experiment.

Materials and methods

Site characterization

The soils used in this study were collected from Malava smallholder farmers in Kakamega District of western Kenya.

The area receives an average annual rainfall of 2,080 mm in two rainy seasons, 'long rains' (March to July) and 'short rains' (September to November). Mean monthly temperatures ranges between 11° and 26 °C. The soils in the experimental site are classified as nitro-rhodic Ferralsols (Jaetzold and Schmidt 1982), with the following characteristics in the top 0–20 cm depth: pH (1:2.5 soil water) = 4.49; % organic carbon = 1.78; % total nitrogen = 0.16; extractable soil inorganic phosphorus (mg kg⁻¹ soil) = 17.14; exchangeable cations (c mol_c kg⁻¹ soil): calcium = 0.14, magnesium = 0.31, sodium = 0.07, potassium = 0.26; clay content = 48.4%, sand = 49.5% and silt = 2.1%. The soils have a textural class of sandy clay, are well-drained, very deep, dark reddish brown to dusty red friable clays. The geology of this area is basic igneous rocks, mainly basalt.

Soil sampling and analysis

Soil sampling was done during a dry period about 2 weeks prior to long rains from 10 m × 10 m subplots. From each subplot 15 soil samples were randomly taken using augers from the 0–20 cm depth and bulked where hence the soils were brought to the laboratory for physical and chemical analysis.

In the laboratory, the soil was air-dried and about 2 kg ground to pass through 2 mm screen for physical and chemical analysis while samples for total nitrogen and total organic carbon determination were ground further to pass through a 0.25 mm mesh sieve. The rest of the soil was stored in polythene bags. Particle size distribution was determined using the Bouyoucos hydrometer method (Bouyoucos 1962); soil pH was determined following the procedure outlined by

Okalebo et al. (1993); moisture content and the gravimetric soil water content at field capacity were determined according to method described by Anderson and Ingram (1993). Total organic carbon was estimated using the Nelson Sommers' procedure (Nelson and Sommers 1975); exchangeable bases in the soil were determined using ammonium acetate as an extractant; available phosphorus in the soil was determined by the Bray No. 2 method (Bray and Kurtz 1945), while total nitrogen was determined by the semi-micro Kjeldahl methods as described by Okalebo et al. (1993).

Sampling and chemical characterization of plant materials

Leaves of six organic residues which were *L. leucocephala*, *C. macrostachyus*, *C. calothyrsus*, *T. diversifolia*, *S. bicolor* and rice (*O. sativa*) were selected. Out of these, two were chosen based on N release and mixed in various proportions for controlled incubation and agronomic experiments. Organic resources were randomly collected from Kabete Campus (University of Nairobi), Kiambu District in Central, Bungoma District and Maseno area of western Kenya. The leaf samples were obtained by randomly selecting 5 fully mature trees. Three branches were selected from each tree: at the bottom most, middle and top canopy, where the leaves were completely removed from each of these branches and sub-samples mixed to make a composite sample. Following the procedure by Anderson and Ingram (1993), 5 kg of fresh leaves was taken to the laboratory and dried in a forced-air oven at 30 °C to avoid loss of soluble polyphenols (Constantides and Fownes 1994). The samples were then ground to pass through a 2 mm size sieve and stored in plastic containers for analysis of nutrient contents (N, P, K, Mg, Ca, lignin and polyphenol) using procedures outlined by Anderson and Ingram (1993) and Okalebo et al. (1993). For total N, P, Ca, Mg, and K in the plant tissues, the samples were re-dried at 65 °C so as to express the nutrients on dry matter basis as recommended by Okalebo et al. (1993). Total nitrogen (N) was estimated by microscopic Kjeldahl digestion followed by distillation (Anderson and Ingram 1993). Using the same digestion solution for N, phosphorus (P) was determined Murphy-Riley ascorbic acid method. Potassium (K) was measured by flame photometry, while magnesium and calcium were estimated from the same solution by atomic absorption spectrophotometer (Anderson and Ingram 1993). Total organic carbon was determined by

Nelson and Sommers methods (Okalebo et al. 1993). Extractable polyphenols was determined by Folin-Denis method while lignin was determined by acid detergent fiber method (Anderson and Ingram 1993).

Experiment 1: Nitrogen mineralization experiment

The incubation procedure was adopted from the work by Palm and Sanchez (1991). Six plant residues (*L. leucocephala*, *C. macrostachyus*, *C. calothyrsus*, *T. diversifolia*, *S. bicolor* and rice (*O. sativa*) of varying qualities were selected based on their chemical characteristics. The selection was based on contrasting nitrogen, lignin and soluble polyphenol contents with these qualities based on the work of Palm (1995). In the nitrogen mineralization experiment, each of the six plant materials, 1.14 g (approximately 5 t ha⁻¹) was mixed with 500 g (dry-weight basis) soil, which had been passed through 2 mm sieve. They were thoroughly mixed then placed in 500 gauge polythene bags. A control of soil alone was included. Deionized water was added to each mixture to attain gravimetric soil water content (25% soil moisture content at field capacity) Anderson and Ingram (1993). The soil and plant mixtures were tightly tied and stored in a dark (21 °C) in the laboratory. Each treatment was replicated 3 times and the experiment laid out in a completely randomized design. Moisture content of the incubated soils was maintained by periodic weighing of the samples and moisture loss made up by adding the deionized water. The samples were incubated for 12 weeks and sampling done after every 2 weeks.

The inorganic nitrogen in form of ammonium (NH₄⁺N) and nitrate (NO₃⁻-N) contents in the soil samples were also determined at 0, 2, 4, 6, 8, 10 and 12 weeks after incubation. Moisture content was also being estimated at each sampling period. Sub-samples weighing 10 g were taken from each bag for mineral nitrogen extraction. The inorganic NO₃⁻N and NH₄⁺N in the samples were determined colorimetrically according to the method described by Anderson and Ingram (1993).

Experiment 2: Nitrogen release from incubated organic mixtures

The plant materials from *C. macrostachyus* (Cm) and *O. sativa* (Os) were mixed on weight basis to give the following ratios: ½ Cm: ½ Os, ¾ Cm: ¼ Os, ¼ Cm:

$\frac{3}{4}$ Os, 1 Cm: 0 Os, 0 Cm: 1 Os. Incubation procedures were followed in the same way as in the nitrogen mineralization experiment. The inorganic N content was determined from samples that were taken at 0, 2, 4, 6, 8, 10 and 12 weeks after incubation. Moisture content was also being estimated at each sampling period. For these sub-samples weighing 10 g were taken and NO_3^- -N and NH_4^+ -N determined colorimetrically following procedure described by Anderson and Ingram (1993).

Experiment 3: Agronomic effectiveness of the selected organic materials on Zea mays (maize)

Growth and N uptake by maize to addition of organic materials of *C. macrostachyus*, *O. sativa*, *T. diversifolia*, and a mixture of $\frac{1}{2}$ Cm: $\frac{1}{2}$ Os and soil was established. Standard plastic pots with a base diameter of 8" were used with each pot containing 2.5 kg of soil (oven dry weight basis). In each pot, a basal application of 114 mg K as K_2SO_4 (100 Kg ha^{-1} K) and 114 mg P in the form of $\text{Ca}(\text{HPO}_4)_2$ (100 Kg ha^{-1} P) was done. The three plant materials and the one mixture were selected from incubation experiment because they had shown that *C. macrostachyus* released the highest amount of N, *O. sativa* immobilized N, while *T. diversifolia* and the mixture of 50% Cm & 50% Os released intermediate amounts of N throughout the sampling period.

To each pot, 5.7 g (equivalent to 5 t ha^{-1} dry weight) of the ground plant residues were added and mixed thoroughly. Two maize seeds, variety H 512 were sown in each pot to a depth of 2.5 cm. Two weeks after planting (2 WAP), the maize seedlings were thinned to one plant per pot. During the growth period, the pots that were placed on workbenches were rotated periodically depending on sunshine and the prevailing ambient temperature. Soil water content was adjusted to replace the loss, three times a week. Each treatment was replicated 9 times to allow for three harvests during the experimental period.

For assessment of maize dry matter yield and nutrient uptake, maize plants were destructively sampled at 3, 5 and 7 WAP. Three pots per treatment were randomly selected and maize plants excised at soil level, placed in standard paper bags No. 2 and dried at 65°C for 48 hours then reweighed for dry matter (DM) measurements. The dried shoots were then ground to pass through 60—mesh size for nutrient (N, P, Ca, and Mg) analysis using procedures outlined by Anderson and

Ingram (1993) and Okalebo et al. (1993). The dynamics of the mineral N (NO_3^- -N and NH_4^+ -N) concentration in the soil in pots were monitored by sampling soil from each pot at each time of harvesting plant samples. The NO_3^- -N and NH_4^+ -N in the extracts were analyzed as described by Anderson and Ingram (1993).

Statistical analysis

Data on N release were analyzed by standard ANOVA using Statistical Analysis Systems (SAS) SAS (1985). Main effects were separated by least significant differences (LSD) at $P = 0.05$ level. Contrasts were used to separate and test the significance of differences due to mixing high quality and low quality plant residues in various ratios. For contrast analysis, the amount of N-released during incubation of mixtures was compared to the predicted N-released obtained from the means of N-released by *C. macrostachyus* (Cm) and *O. sativa* (Os) individually. Treatment differences in the glasshouse experiment were analyzed with the general linear model procedure (GLM) (SAS 1985). Under GLM, the sources of variation in the experiments included residue chemical contents and sampling periods.

Results

Soil physical and chemical characteristics of the experimental site

The physical and chemical characteristics of the soil from Malava (Kakamega District) are given in Table 1. The soil is strongly acidic, moderate in sodium, high in potassium and magnesium, but low in calcium according to Okalebo et al. (1993). It was also noted to be moderate in nitrogen and total carbon contents. The soil textural class was found to be sandy clay.

Chemical composition of organic materials

Large differences in the chemical composition of the six organic residues were observed (Table 2). Nitrogen content ranged from 0.63% in the cereals (*S. bicolor* and *O. sativa*) to 3.97% in *T. diversifolia*. As expected the N concentration of legume species were 5–6 times higher than that of the grasses (Lefroy et al. 1992). The C:N ratios of the cereals were consequently much greater than those of legumes. The legumes generally

Table 1. Physical and chemical characteristics of soil from Malava, Kakamega District

Parameters of surface soil (0–20 cm)	Values
PH (1:2.5 soil water)	4.49
Organic carbon (%)	1.78
Total nitrogen (%)	0.16
Bray P (mg kg ⁻¹ soil)	17.17
Exchangeable cations (c mol _c kg ⁻¹ soil)	
Calcium	0.14
Magnesium	0.31
Sodium	0.07
Potassium	0.26
Texture (%)	
Sand	49.5
Clay	48.4
Silt	2.1
Textural class	Sandy clay

had higher concentration of P, K, Ca and Mg. The total phosphorus content in these materials ranged from 0.10% in *S. bicolor* to 0.31% in *T. diversifolia*; potassium ranged from 0.38% in *O. sativa* to 4.44% in *T. diversifolia*; calcium levels ranged from 0.1% in *O. sativa* to 1.55% in *T. diversifolia*; while magnesium contents ranged from 0.04% in *O. sativa* to 0.45% in *C. macrostachyus*. Polyphenol concentration however tended to be higher in legumes than in cereals. Soluble polyphenols was absent in *O. sativa* and highest in *L. leucocephala*, while lignin was highest in *C. calothyrsus* but lowest in *S. bicolor*.

Correlation analysis between chemical characteristics of plant tissues indicated that polyphenols had a weak but positive correlation of ($r^2=0.62$) with the N contents (Table 3). However, lignin did not correlate with any of the other measured chemical parameters. Initial P concentrations had a strong and positive correlation with N concentrations ($P<0.001$). The ratios of carbon to nitrogen (C:N), lignin to nitrogen (LG:N),

and lignin plus polyphenol to nitrogen (LG+PP:N) were negatively correlated with P contents of various plant tissues, while polyphenol to nitrogen (PP:N) ratio had a significant ($P<0.05$) negative correlation with carbon.

Nitrogen mineralization and release patterns

The cumulative mineral N in the control treatment showed a gradual increase of 19.7 to 57.3 $\mu\text{g N g}^{-1}$ soil during the 12-week incubation period (Table 4). Rapid increase in cumulative soil mineral N was observed in soils in which *C. macrostachyus*, *L. leucocephala*, *C. calothyrsus* and *T. diversifolia* were incorporated. Upon mixing *O. sativa* and *S. bicolor* leaves separately with soil, cumulative mineral N release values for *S. bicolor* (16.0–41.33 $\mu\text{g N g}^{-1}$ soil) and (17.67–58 $\mu\text{g N g}^{-1}$ soil) for *O. sativa* husks were lower than that of control (19.67–57.33 $\mu\text{g N g}^{-1}$ soil) during the incubation period (Table 4).

Incorporation of *S. bicolor* leaves resulted in net immobilization throughout the 12-week incubation period while inclusion of *O. sativa* husks resulted in a net immobilization in the first weeks followed by a slow N release. The net inorganic N released at 12 weeks of incubation varied significantly among species. The net N released ranged from -16.33 $\mu\text{g N g}^{-1}$ (net immobilization) for *S. bicolor* to 43.33 $\mu\text{g N g}^{-1}$ (net mineralization) for *L. leucocephala* (Fig. 1). Two observations were made: (1) even after 12 weeks N could still be released from the organic residues (see slope after 10th week), (2) organic materials were in two distinctive groups i.e. low quality (*S. bicolor* and *O. sativa*) and high quality (*C. macrostachyus*, *L. leucocephala*, *C. calothyrsus* and *T. diversifolia*).

Table 2. Chemical composition of the selected plant residues

Species	Chemical composition (%)											
	C	N	Ca	Mg	P	K	PP	LG	C:N	LG:N	(LG+PP):N	PP:N
<i>C. macrostachyus</i>	37.50	3.30	1.02	0.45	0.29	4.03	1.37	8.40	11.36	2.55	2.96	0.42
<i>L. leucocephala</i>	36.00	3.74	1.16	0.33	0.26	3.37	6.13	14.68	9.63	3.92	5.56	1.64
<i>C. calothyrsus</i>	38.70	3.64	0.66	0.24	0.22	1.88	5.36	28.71	0.63	7.89	9.36	1.47
<i>T. diversifolia</i>	39.00	3.97	1.53	0.40	0.31	4.44	3.39	3.68	9.82	3.45	4.30	0.85
<i>S. bicolor</i>	39.90	0.63	0.49	0.14	0.10	1.40	2.92	4.23	63.33	6.71	11.35	4.63
<i>O. sativa</i>	33.00	0.63	0.10	0.04	0.14	0.38	0.00	16.66	52.38	26.44	26.44	0

Where: PP= polyphenol; C:N= Carbon to nitrogen ratio; LG= lignin; LG:N= lignin to nitrogen ratio; (LG+PP):N= (lignin+ polyphenol) to nitrogen ratio; PP:N= polyphenol to nitrogen ratio.

Table 3. Correlation coefficients of various chemical properties

Properties	N	LG	PP	C	P	C:N	LG:N	(L+PP):N	PP:N
Nitrogen (N)	1.00	0.43	0.62*	0.45	0.86***	-0.88***	-0.63*	-0.69*	-0.20
Lignin (LG)		1.00	0.36	-0.04	0.10	-0.38	0.24	0.18	-0.32
Polyphenol (PP)			1.00	0.62*	0.30	-0.39	0.47	-0.39	-0.49
Carbon (C)				1.00	0.23	0.16	-0.66*	-0.55	-0.67*
Phosphorus (P)					1.00	-0.86***	-0.68*	-0.78*	-0.36

*P<0.05; **P<0.01; ***P<0.001.

Table 4. Effect of organic residues on cumulative mineral N (NO₃⁻-N + NH₄⁺-N) release in µg g⁻¹ soil

Residues	Time (Weeks)					
	2	4	6	8	10	12
Cm	40.00a	46.00a	74.67a	74.33a	81.33a	98.33a
Ll	35.00a	46.00a	67.00a	71.33a	76.00a	101.00a
Cc	35.67a	44.33a	63.33b	58.67b	68.33b	92.33b
Td	35.67a	45.67a	59.33b	64.00b	68.33b	81.33c
Sb	16.00b	18.00c	18.33d	23.99d	25.33d	41.33e
Os	17.67b	27.00b	39.00c	42.67c	47.67c	58.00d
Control	19.67b	21.00c	44.00c	43.67c	49.33c	57.33d
LSD _{0.05}	7.35	11.72	9.62	5.68	6.17	6.05

Within a column, means followed by the same letter are not significantly different according to Fisher's LSD at 5% probability level. Cm= *Croton macrostachyus*; Ll= *Lucaena leucocephala*; Cc= *Calliandra calothyrsus*; Td= *Tithonia diversifolia*; Sb= *Sorghum bicolor*; Os= *Oryza sativa*.

Mixtures of high quality and low quality organic residues and effect on N release

The effects of mixing *C. macrostachyus* (Cm) and *O. sativa* (Os) on the amount of mineral N released varied greatly depending on the amount of Cm added. In the absence of Cm, addition of Os in the soil suppressed the amount of N-mineralized to less than that of soil alone. When Cm and Os mixture was incorporated into the soil, a net N release was recorded and the release patterns were similar to those of Cm and Os (Figure 2).

A contrast was computed to determine if the N accumulated from the mixtures of Cm and Os could be predicted from the amounts released by Cm and Os residues separately. It was observed that generally there was no significant difference between the amount of N released during the incubation of the mixtures and the predicted N-release (Table 5). However treatments with ¾ Cm and ¼ Os mixture showed a significant reduction in N-released at week 6–8 compared to ¼ Cm and ¾

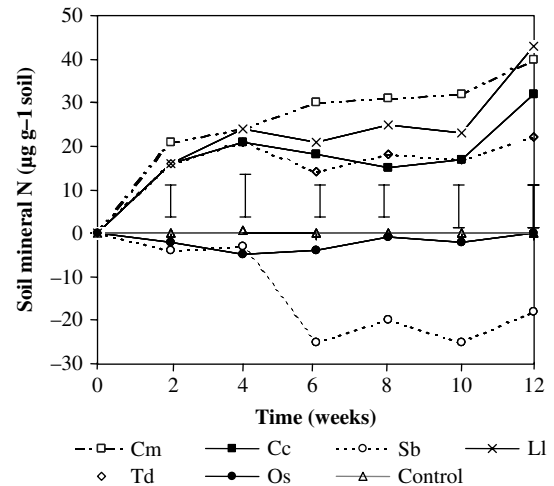

Figure 1. Changes in net inorganic soil N during 12-week incubation period as affected by addition of plant residues of contrasting chemical composition. Bars represent LSD at P<0.05. Cm= *Croton macrostachyus*; Ll= *Lucaena leucocephala*; Cc= *Calliandra calothyrsus*; Td= *Tithonia diversifolia*; Sb= *Sorghum bicolor*; Os= *Oryza sativa*.

Os mixture that had significantly higher N-release at weeks 2 and 12. These significant differences meant that there were strong interactions between Cm and Os at these stages of decomposition.

Agronomic effectiveness of organic residues on maize growth

The effect of incorporating plant residues in soil on maize growth was evident from the early stages (Table 6). The above ground biomasses were higher in residue treated plots than in the control. For example, at 3 WAP above ground biomass was 29–58% higher in pots that had received plant residues. At 5 WAP it was 24–62% higher while at 7 WAP it was 3–38% higher than in the control treatments. At 7 WAP the highest response to residue application was obtained

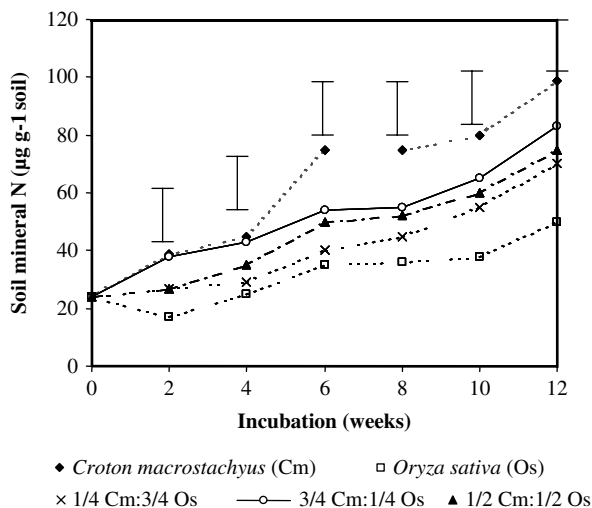

Figure 2. Changes in soil inorganic N release during 12week incubation as affected by addition of mixtures of *C. macrostachyus* (Cm) and *O. sativa* (Os) in various ratios to the soil. Bars represent LSD at P<0.05.

Table 5. The amount of mineral N released during incubation in excess of that predicted by mixing Cm and Os ($\mu\text{g g}^{-1}$ soil)

Time (weeks)	1/2 Cm + 1/2 Os	1/4 Cm + 3/4 Os	3/4 Cm + 1/4 Os
2	-1.17	5.08*	3.92
4	2.17	-0.75	2.75
6	-4.83	-3.92	-8.75**
8	-3.50	-2.42	-5.58**
10	-1.67	0.00	-2.67
12	-0.17	5.92**	-2.58

Where: *P<0.05; **P<0.01; Cm=*Croton macrostachyus*; OS=*Oryza sativa*; In the table, a contrast that did not show significant difference from the predicted N-release (i.e [amount of N by Cm + amount of N by Os]/2) indicated that the values for Cm and Os mixtures can be predicted from the sum of Cm and Os release curves.

Table 6. Dry matter production by maize plants in soil treated with various plant residues

Treatment	Maize dry weight (g/pot)		
	Time in weeks after planting (WAP)		
	3	5	7
Control	0.24a	0.68a	1.45a
<i>C. macrostachyus</i> (Cm)	0.36b	0.95bc	1.70b
<i>O. sativa</i> (Os)	0.31ab	0.84ab	1.48a
1/2 Cm + 1/2 Os mixture	0.38b	1.10c	2.00c
<i>T. diversifolia</i>	0.34b	0.93bc	1.81bc
LSD 0.05	0.09	0.22	0.22

Within a column, means followed by the same letter are not significantly different at P<0.05.

Table 7. Influence of inorganic residue addition on N uptake by Maize

Treatment	N uptake in mg/plant		
	Time in weeks after planting (WAP)		
	3	5	7
Control	9.29a	14.55a	20.60a
<i>C. macrostachyus</i> (Cm)	13.34b	21.09b	33.32c
<i>O. sativa</i> (Os)	11.32ab	16.78a	19.98a
1/2 Cm + 1/2 Os mixture	14.86c	23.82bc	29.76b
<i>T. diversifolia</i>	12.99bc	24.46c	32.76bc
LSD ^{0.05}	2.43	4.84	2.98

Within a column, means followed by the same letter are not significantly different at P<0.05.

from addition of 1/2 Cm + 1/2 Os mixture followed by the *T. diversifolia* (Td), and Cm-treatments. Application of Os husks alone did not differ from that of the control treatment.

Nitrogen uptake by Zea mays (maize)

Addition of organic residues had a significant effect on maize N uptake (Table 7). The control and Os treatments gave low N uptake values ranging from 9.29 to 20 mg N per plant while, the other organic residues, in particular, *C. macrostachyus*, 1/2 Cm + 1/2 Os and *T. diversifolia* resulted in 62%, 59%, and 44%,- increase in N uptake, respectively above that of the control. In all the treatments, maize N uptake was highest at 7 WAP but lowest at 3 WAP. Maize N uptake was 77–150% higher at 7 WAP than at 3 WAP. Apparently these are the same periods when respective maize growths were highest and lowest indicating that synchrony can be exploited during these times to enhance both N uptake and maize growth.

Discussion

Characteristic of soil and organic residues

The soils in the study area are developed from basic parent materials, mainly basalts (Jaetzold and Schmidt 1982). Thus, it was expected that the soil pH (H₂O) would be higher than 5.2 (Deckers 1993). The strong acidity could be attributed to leaching of bases from

the topsoil to deeper horizons as the area receives high rainfall. These soils, being Ferralsols, are highly weathered with soil materials consisting of Kaolinite, quartz and hydrated oxides (Ssali, et al. 1986). Thus, the capacity of these soils to supply nutrients to the plants as well as their capacity to retain nutrients is both low. From a soil fertility perspective, the low nutrient retention capacity has marked consequences for fertilizer management especially nitrogen which is normally leached before plants utilize it (Dekkers 1993).

As expected the N concentration of legume species were 5–6 times higher than that of cereals. The C:N ratios of the cereals were consequently much greater than those of legumes. The legumes generally had higher concentration of P, K, Ca and Mg. Polyphenol concentration however tended to be higher in legumes than in cereals. Similar results were expressed by Lefroy et al. (1992), who found that leguminous trees and shrubs contained higher polyphenol, astringent compounds and ash than grasses. The higher N content in the legumes could be due to the accumulation of symbiotically fixed N (Rubaduka et al. 1993).

Nitrogen mineralization and release patterns

The high nitrate proportion observed from organic materials collected from farms may have been due to the fact that no leaching occurred in the bags as oxidation of NH_4^+ -N took place during incubation. Low N-mineralization pattern observed in *T. diversifolia* was not expected because the organic material was high in N and medium lignin and polyphenolic contents. The fact that not all polyphenol compounds have equivalent capacity to bind protein or nitrogen may explain this observation (Martin and Martin 1982; Handayanto et al. 1994). Hence *T. diversifolia* may have a higher proportion of a type of polyphenol that binds nitrogen, which delayed the rate of decomposition and net mineralization.

The net immobilization of N took place in treatments that *O. sativa* and *S. bicolor* leaves were incorporated due to the high C:N ratio. Net mineralization expected to occur in materials with a C:N ratio equal or lower than that of the decomposer organisms which is usually about 20 (Swift et al. 1979). In the case of *O. sativa* and *S. bicolor* the ratios range from 52 to 63. Such trends of N immobilization after soil amendments with organic resources of high C:N ratios were observed by Ladd et al. (1977) and Azam et al. (1986, 1988).

In this study net mineralization for *O. sativa* treatment was detected before the end of the 12th week. However, the trend shown by *S. bicolor* indicates that N-release is expected sometimes after the 12th week. This could be explained by either or both of the following: First, during mineralization of an organic material, carbon in the material usually mineralizes faster than the nitrogen component hence with time the C:N ratio of the material decreases (Sanchez 1976). Based on this, Stevenson (1982), suggested that net N immobilization from organic material with a high C:N ratio mixed with soil, lasts until the C:N ratio of the decomposing organic materials has been lowered to approximately 20. In this study, The C:N ratios of *O. sativa* and *S. bicolor* were 52 and 63 respectively. Accordingly, it was expected that *O. sativa* husks would start showing net release before *S. bicolor* leaves, as confirmed by this experiment. Second, the presence of higher polyphenol content in *S. bicolor* leaves might have consisted largely of micromolecules with higher stability that was slowly utilized by the microorganisms (Quemada and Cabrera 1995).

Based on the initial quantity of N added to the soil, the results of this experiment and the quantities recovered at the end of 12 weeks showed that not all the mineralized N was recovered. This and this might have been due to fixation of NH_4^+ on the clay lattices that was not accounted for in the final balance (Ladd et al. 1977).

Effect of chemical composition on N release

Organic resource quality is defined by its organic composition and contents. The most important chemical factors influencing decomposition, nutrient release and soil organic matter dynamics are carbon and nitrogen (especially the C: N ratio), lignin and polyphenols (Handayanto et al. 1994; Palm 1995; Mafongoya et al. 1998). Other factors include the environmental conditions and the decomposer organisms (Trofyman et al. 1995; Swift 1995). Among the plant indices that were shown to be effective in determining the rate of decomposition and nutrient release include C:P, N:P, C:N, PP:N, L:N and L+PP:N. However, their effects depend on the length of incubation and the type of material (Palm 1995; Mafongoya et al. 1998).

In this study, initial N and P contents, C:N, PP:N seem to be the best predictors of the rate of N release from the organic materials. The correlation between the initial N and P contents with N accumulation over the

incubation period agrees with the findings of Frankenberger and Abdelmagaid (1985) and Tian et al. (1992a). This is probably because nutrient concentration particularly N and P are measured in high amounts and sustained the activity of the decomposer organisms which require these two elements in large quantities for their growth and development (Swift et al. 1979).

The correlation coefficient between lignin and N accumulation was low (ranging from -0.27 to -0.49). This indicates that, although lignin has been shown to be an important index by Melillo et al. (1982); Palm and Sanchez (1991); Oglesby and Fownes (1992) and Tian et al. (1992b), lignin content could not satisfactorily explain the differences in the N release between the different plant materials.

Whereas polyphenol content alone was not a strong predictor of decomposition rate and N release patterns, polyphenol-derived variable such as PP:N was an important predictor of N release. Initial polyphenol content was found to have no influence on N release from various plant residues but the polyphenol:N ratio had a negative influence on N mineralization. Constantinides and Fownes (1994) reported similar correlation of polyphenol:N ratio but not polyphenol alone on N-mineralization. Thus, the polyphenol:N ratio could be used to predict N-mineralization of the various plant residues.

This scenario may be explained by the fact that the effect of polyphenol on N-release was due to the interaction of the polyphenolics with N (Palm and Sanchez 1991; Handayanto et al. 1994). For instance some polyphenols do form complex structures by H-bonding with basic N-containing groups, others form stable cross linkages with amino groups making the organic molecule resistant to decomposition (Swain 1979). Phenolics are also readily oxidized to quinones which react with nitrogen in amino acids and amino sugars to form stable polymers that are recalcitrant and difficult to break down (Martin and Haider 1980; Bray, 1983).

The observed N release pattern in the case of mixing $\frac{1}{4}$ *C. macrostachyus* and $\frac{3}{4}$ *O. sativa* could be due to the easily decomposable *C. macrostachyus* which enhanced microbial activity during the first 2 weeks hence increasing the decomposition rates and thus significant release of N. This is because mixing *C. macrostachyus* and *O. sativa* reduce the C:N ratio of *O. sativa* by 50% from 52.4 to 25.3 thus contributing to the high N-release. The speculated high microbial activity following addition of high quality organic material was observed by Collins et al. (1990) from 30-day

incubation using wheat plant. They observed up to 25% increase with respect to the amount predicted by summing up CO₂ evolution from individual components.

After 4 weeks, the easily decomposable *C. macrostachyus* had been completed and the microorganisms were subjected to the remaining less decomposable *O. sativa* with a high C:N ratio. This could possibly explain the reduction in N release between 6–8 weeks for $\frac{3}{4}$ **Cm** + $\frac{1}{4}$ **Os mixtures**. A decline of nutrients may have resulted in reduced bacterial activity hence a reduced N-release (Struwe and Kjoller 1986). However, as the C:N ratio of *O. sativa* kept on decreasing with decomposition (Sanchez 1976), N release increased though below the predicted values. The results of this experiment are consistent with those obtained by Struwe and Kjoller (1986) who found that when nitrogen rich alder litter was mixed with nitrogen poor ash litter, there was initially high population of starch and gelatin utilizing bacteria but bacteria population declined when the alder litter was depleted. These authors suggested that the population shift was related to the progressive decomposition and consequently to the depletion of easily available nitrogen and energy sources.

Agronomic effectiveness of the organic residues on maize yield

The high yields observed in the pots treated with *C. macrostachyus* and *O. sativa* mixture may have been due to resulting better plant growth (Yamoah et al. 1986). Another possible explanation is that, the high carbon portion of *O. sativa* in the mixture may have enhanced the activity of N₂-fixing rhizosphere bacteria associated with maize plant. Martin et al. (1989), using high carbon millet straw and low carbon *Gliricidia sepium* in maize field, observed that millet straw, unlike *Gliricidia*, significantly enhanced the activity of N₂-fixing bacteria in the maize rhizosphere. This enhanced microbial activity could have led to more mineral N being available to the maize plants during the turnover of the bacteria than was the case with *C. macrostachyus*. Also, the work of Van der Meersch et al. (1993) revealed that in cases where a highly decomposable organic material has been added to the soil, the ability of microorganisms living in the soil to fix nitrogen is reduced.

Higher yields with use of organic residues have been reported (Gachengo 1996; Palm 1996; Gachengo et al. 1999; Ayuke 2000). Gachengo (1996) and Ayuke

(2000) showed that tithonia could increase maize yields by 1½ times above the no input control. Similarly Mulongoy and Van der Meersch (1988) observed a 1½ times increase in yield over no input control using *L. leucocephala* and maize stover as organic amendments.

Soil mineral N dynamics and uptake by maize

There was general decline in extractable soil N as a result of plant N uptake as reported by Tian et al. (1993) and Franzluebbers et al. (1994). Some short-term immobilization was expected in pots with *O. sativa* having a high C:N ratio of 52 (Iritani and Arnold 1960). However, the high day temperatures of over 35 °C in the glasshouse compared to the low laboratory incubation temperatures (21°C-room temperature) may have increased microbial activities leading to the net release. Increase in N uptake by maize in presence of plant residues implied that some of these residues are potential candidates that could be used as sources or supplements of inorganic-N fertilizers in maize production.

Conclusions

The study indicates that: (1) N and P contents were positively correlated while C:N and polyphenol:N ratios were negatively correlated with N release under controlled incubation conditions and may be used as indicators for predicting N released from plant residues, (2) Incorporation of *S. bicolor* leaves resulted in N immobilization, (3) Generally mixing low quality and high quality plant materials resulted in higher N release during the first 4 weeks. Incorporation of ¾ *C. macrostachyus*: ¼ *O. sativa* mixture caused a significant suppression of the N released from the high quality residue at the 6–8th week. This effect is likely to improve N use efficiency through reduction of N losses with a positive N residual effect on the succeeding crops, (4) Although results from incubation studies could be used to predict N release patterns and accumulation from various plant residues, they are likely not to be the best for the estimation of plant uptake and response to N released from incorporation of residues, (5) The mixture treatment of ½ *C. macrostachyus* + ½ *O. sativa* contributed significantly to maize growth than the high quality *C. macrostachyus* alone implying that mixing low quality and high quality plant residues

in a proper ratio could be a prerequisite for synchronizing soil nutrient supply and crop nutrient demand (6) Determination of N levels in the soil solution during the plant growth period was shown to be a better tool for evaluating the possible N contribution of plant residues to the crops as uptake in maize was correlated with the extractable soil N.

In areas where *O. sativa* husks are available, it is recommended that the husks should be mixed with either *C. macrostachyus* or *L. leucocephala* in ratio of ½ to ½ before they are incorporated into the soil for them to supply sufficient N for maize growth. However, availability of the suggested high quality plant materials was beyond the scope of this study. Consequently it is recommended that research to assess availability, acceptability of the organic resources by farmers and their decay patterns in the field should be carried out.

Acknowledgements

The study was conducted from funds received from the Swedish Agency for Research Corporation (SAREC), Tropical Soil Biology and Fertility (TSBF) Institute of CIAT and Rockefeller Foundation (FORUM) Programmes. We would wish to thank our anonymous reviewers who gave constructive criticism most of which have gone a long way in strengthening this paper.

References

- Anderson J.M. and Ingram J.S.I. 1993. Tropical Soil Biology and Fertility: A handbook of the methods. 2nd edition. CAB International, Wallingford, United Kingdom, 221 pp.
- Ayuke F.O. 2000. Diversity, abundance and function of soil invertebrate fauna in relation to quality of organic residues. M.Phil thesis, Moi University, Eldoret, Kenya.
- Azam F., Malik K. and Hussein F. 1986. Microbial biomass and mineralization of nitrogen in some agricultural soils. *Biology and Fertility of Soils* 2: 157–163.
- Azam F., Mahmood T. and Malik K.A. 1988. Immobilization-remobilization of glucose, sucrose and cellulose in soil incubated at different moisture regimes. *Plant and Soil* 107: 159–163.
- Baldock J.O. and Musgrave R.B. 1980. Manure and mineral fertilizer effects in continuous and rotational crop sequences in central New York. *Agronomy journal* 72: 511–518.
- Batiano A. and Mokwunye A.Y. 1991. Role of manure and crop residues in alleviating soil fertility constraints to crop production. *Fertilizer Research* 29: 117–125.
- Bouyoucos G.J. 1962. Hydrometer method improved for making particle size analyses of soils. *Agronomy Journal* 53: 464–465.
- Bray C.M. 1983. Nitrogen metabolism in plants. Longman Inc, New York, USA, pp. 197–199.

- Bray R.H. and Kutz L.T. 1945. Determination of total organic and available phosphorus in soils. *Soil Science* 159: 39–45.
- Collins H.P., Elliot L.F., Rickman R.W., Bezdicke D.F. and Papendick R.I. 1990. Decomposition and interactions among wheat residue components. *Soil Science Society of America Journal* 54: 780–785.
- Constantides M. and Fownes J.H. 1994. Nitrogen mineralization from leaves of and litter of tropical plants. Relationships to nitrogen, lignin, and soluble polyphenol concentrations. *Soil Biology and Biochemistry* 26: 49–55.
- Deckers J. 1993. Soil fertility and environmental problems in different ecological zones of the developing countries in sub-Saharan Africa. In: Reuler H. and Prins W.H. (Eds). *The role of plant nutrients for sustainable food crop production in sub-Saharan Africa*, pp. 37–52, Ponsen and Louijen, Wageningen, Netherlands.
- Frakenberger W.T. and Abdelmagaid H.M. 1985. Kinetic parameters in nitrogen mineralization rates of leguminous crops incorporated into soils. *Plant and Soil* 87: 251–271.
- Franzuebbers K., Weaver R.W., Juo A.S.R. and Franzuebbers A.J. 1994. Carbon and nitrogen mineralization from cowpea plant parts decomposing in moist and repeatedly dried and wetted soil. *Soil Biology and Biochemistry* 26(10): 1379–1387.
- Fu M.H., Yu X.C. and Tabatabai M.A. 1987. Effect of pH on nitrogen mineralization rates of leguminous crops incorporated into soil. *Plant and Soil* 87: 257–271.
- Gachengo C.N. 1996. Phosphorus (P) release and availability on addition of organic materials to phosphorus fixing soils. M.Phil thesis, Moi University, Eldoret, Kenya.
- Gachengo C.N., Palm C.A., Jama B. and Othieno C. 1999. Tithonia and senna green manures and inorganic fertilizers as phosphorus sources for maize in Western Kenya. *Agroforestry Systems* 44: 21–36.
- Handayanto E., Cadisch G. and Giller K.E. 1994. Nitrogen release from prunings of legume hedgerow trees in relation to quality of the prunings and incubation method. *Plant and Soil* 160: 237–248.
- ICRAF 1996. International Centre for Research in Agroforestry. Annual Report, ICRAF, Nairobi, Kenya, 286p.
- Iritani W.M. and Arnold C.Y. 1960. Nitrogen release of vegetable crop residues during incubation as related to their chemical composition. *Soil Science* 89: 74–82.
- Jaetzold R. and Schmidt H. 1982. *Farm Management Handbook of Kenya. Natural Conditions and Management Information Vol. II/A*. Ministry of Agric. Kenya.
- Kang B.T. 1988. Nitrogen cycling in multiple cropping systems. In: Wilson J.R. (Ed.) *Advances in Nitrogen Cycling in Agricultural Ecosystems*, pp. 333–348. CAB International.
- Kang B.T. and Wilson G.F. 1987. The development of alley cropping as a promising agroforestry technology. In: Stepler H.A. and Nair P.K.R. (Eds) *Agroforestry a decade of Development*, pp. 227–243. ICRAF, Nairobi.
- Kang B.T., Sipken L., Wilson G.F. and Nagju D. 1981. *Leucaena [Leucaena leucocephala (Lam) de Wit] prunings as nitrogen sources for maize (Zea mays)*. *Fertilizer Research* 2: 279–287.
- Ladd J.N., Parsons J.W. and Amato M. 1977. Studies of nitrogen immobilization in calcareous soils: Mineralization of immobilized nitrogen from soil fractions of different particle sizes and density. *Soil Biology and Biochemistry* 9: 319–325.
- Lefroy E.C., Dann P.R., Wildin J.H., Wesley R.N.S. and McGowan A.A. 1992. Trees and shrubs as a source of fodder in Australia. *Agroforestry systems* 20: 117–139.
- Mafongoya P.L., Giller K.E. and Palm C.A. 1998. Decomposition and nitrogen release patterns of tree prunings and litter. *Agroforestry systems* 38: 77–97.
- Martin P., Glatzle A., Kolb W., Omay H. and Schmidt W. 1989. N₂-fixing bacteria in the rhizosphere. Quantification and hormonal effects of carbon sources on root development. *Z. Pflanzenernah Bodenkd* 152: 237–245.
- Martin J.S. and Martin M.M. 1982. Tannin essays in ecological studies: Lack of correlation between polyphenolics. Protoanthocyanidine and protein precipitating constituents in mature foliage of six oaks species. *Oecologia* 54: 205–211.
- Martin J.P. and Haider K. 1980. Microbial degradation and stabilization of ¹⁴C-labelled lignins, polyphenols and phenolic polymers in relation to soil humus formation. In: Kirk T.K., Hinguchi T. and Chang H.M. (Eds) *Lignin Biodegradation, Microbiology, Chemistry and Potential Applications, Vol. 2*, pp. 78–100, CRS press. West Palm Beach.
- Melillo J.M., Aber J.D. and Muratore J.F. 1982. Nitrogen and lignin control of hardwood leaf litter decomposition dynamics. *Ecology* 63: 621–626.
- Mulongoy K. and Meersch M.K. van der. 1988. Nitrogen contribution by *Leucaena (Leucaena leucocephala)* prunings to maize in an alley cropping systems. *Biology and Fertility of Soils* 6: 282–285.
- Myers R.J.K., Palm C.A., Cuevas E., Gunakilleke I.U.N. and Brossard M. 1994. The synchronization of nutrient mineralization and plant nutrient demand. In: Woomer P.L. and Swift M.J. (Eds) *Biological Management of Tropical Soil Fertility*, pp. 81–116. Wiley-Sayce, New York, and Exeter, UK.
- Nelson D.W. and Sommers L.E. 1975. A rapid and accurate method for estimating organic carbon in soil. *Proceedings of the Indiana Academy of Science* 84: 456–462.
- Niang A., Amadalo B., Gathumbi S. and Obonyo C. 1996. Maize yield response to green manure application from selected shrubs and tree species in Western Kenya: A preliminary assessment. In: Mugah J.O. (Ed.) *People and Institutional Participation in Agroforestry for Sustainable Development*, pp. 35–358. KEFRI, Nairobi, Kenya.
- Oglesby K.A. and Fownes J.H. 1992. Effects of chemical composition on nitrogen mineralization from green manures of 7 tropical leguminous trees. *Plant and Soil* 143: 127–132.
- Okalebo J.R., Gathua K.W. and Woomer P.L. 1993. *Laboratory Methods of Soil and Plant Analysis. A working manual*. TSBF, Nairobi, Kenya. 88p.
- Palm, C.A. 1996. *Nutrient Management: Combined use of organic and inorganic Fertilizers for increasing soil phosphorus availability*. Annual Report of Tropical Soil Biology and Fertility Programme, TSBF, Nairobi, Kenya.
- Palm C.A. 1995. Contribution of agroforestry trees to the nutrient requirements of intercropped plants. *Agroforestry systems* 30: 105–124.
- Palm C.A. and Sanchez P.A. 1991. Nitrogen release from the leaves of some tropical legumes as affected by their lignin and polyphenolic contents. *Soil Biology and Biochemistry* 28: 83–88.
- Palm C.A., Myers R.J.K. and Nandwa S.M. 1997. Combined Use of Organic and Inorganic Nutrient Sources for Soil Fertility Maintenance and Replenishment. In: Buresh R., Sanchez P.A. and Calhoun F. (Eds) *Replenishing Soil Fertility in Africa*. Soil Science Society of America (SSSA). Special publication No. 51, USA.

- Quemada, M. and Cabrera, M.L. 1995. Carbon and nitrogen mineralized from the leaves and stems of four cover crops. *Soil Science Society of America Journal* 59(2): 286–324.
- Rao M.R., Niang A., Kwesiga F.R., Duguma B., Franzel S., Jama B. and Buresh R. 1998. Soil fertility replenishment in sub-Saharan Africa: New techniques and the spread of their use on farms. *Agroforestry Today* 10(2): 3–8.
- Rubaduka E.B., Cadisch G. and Giller K.E. 1993. Mineralization of nitrogen in woody legume prunings and its recovery by maize. In: Mulongoy K. and Merckx R. (Eds) *Soil Organic matter Dynamics and Sustainability of Tropical Agriculture*, pp. 181–188. Proceedings of International Symposium organized by IITA/KU Leuven.
- Sanchez P.A. 1976. *Properties and Management of Soils in the Tropics*. A Wiley-Inter-Science Publication. John Wiley and Sons, New York, USA.
- SAS. 1985. *SAS User's Guide: Statistics 1985 Ed.* Statistical Analysis System Institute Inc., Cary, North Carolina, USA.
- Ssali H., Ahn P.M. and Mokwunye A. 1986. Fertility of Soils of Tropical Africa. A perspective, management of nitrogen and phosphorus fertilizers in sub-Saharan Africa, pp. 59–89. Proceedings of a symposium, Lome Togo.
- Stevenson F.J. 1982. *Humus Chemistry. Genesis, Composition and Reactions*. John Wiley and Sons, USA.
- Struwe S. and Kjoller A. 1986. Changes in population structure during decomposition. In: Jensen V., Kjoller A. and Sorensen L.H. (Eds) *microbial communities in soil*, pp. 149–162. Proceedings of Federal European Microbiological Society Symposium. Copenhagen, Denmark.
- Swain T. 1979. Phenolics in the Environment. In: Swain T., Hairborne K.B. and Van Sumere C.F. (Eds) *Recent Advances in Phytochemistry: Biochemistry of Plant Phenolics*, pp. 617–640.
- Swift M.J. 1995. Soil biology and soil fertility in the tropics. In: Reddy M.V. (Ed.) *Soil Organisms and Litter Decomposition in the Tropics*. Oxford and IBH publishing Co. PVT. LTD, New Delhi.
- Swift M.J., Heal O.W. and Anderson J.M. 1979. *Decomposition in Terrestrial ecosystems*. Blackwell Scientific publications, Oxford, U.K. 372pp.
- Tian G., Kang B.T. and Brussaard L. 1993. Mulching effect of plant residues with chemically contrasting composition on maize growth and nutrient accumulation. *Plant and Soil* 153: 179–187.
- Tian G., Kang B.T. and Brussaard L. 1992a. Effects of chemical composition on N, Ca and Mg release during incubation of leaves from selected agroforestry and fallow plant species. *Biogeochemistry* 16: 103–119.
- Tian G., Kang B.T. and Brussaard L. 1992b. Biological effects of plant residues with contrasting chemical composition under humid tropical conditions: decomposition and nutrient release. *Soil Biology and Biochemistry* 24: 1051–1060.
- Trofyman J.A., Preston C.M. and Prescott C.E. 1995. Litter quality and its potential effect on decomposition rates of materials from Canadian forests. *Water, Air, and Soil Pollution* 82: 215–226.
- Van Der Meersch M.K., Merckx R. and Mulongoy K. 1993. Evolution of plant biomass and nutrient content in relation to soil fertility changes in two alley cropping systems. In: Mulongoy K. and Merckx R. (Eds) *Soil Organic Matter Dynamics and Sustainability of Tropical Agriculture*, pp. 143–154. Proceedings of International Symposium. IITA/KU Leuven.
- Yamoah C.F., Agboola A.A. and Wilson G.F. 1986. Nutrient contribution and maize performance in alley cropping systems. *Agroforestry Systems* 4: 247–254.

Mycorrhizal associations as indicators of forest quality after land use practices

Onguene N. A.

Tropenbos Cameroon Programme, Box 219, Kribi, Cameroon. Current address: Department of Soils, Water & Atmosphere, Institute of Agricultural Research for Development (IRAD), P.O. Box: 2067, Yaoundé, Cameroon, Tel. +237-9464562/7656376; Fax: +237-223-35-38; Email: nereeo@yahoo.fr

Abstract

Counting mycorrhizal infective propagules (spores, fruitbodies, colonized roots) in forest soils was used to assess impacts of shifting cultivation and selective logging on habitat partitioning and abundance of inoculum of arbuscular mycorrhizal and ectomycorrhizal fungi in south Cameroon. Intact soil cores, disturbed soil samples and fruitbodies were collected from late successional forest stands inside and outside the crown projection of ectomycorrhizal clumps, early successional forest stands, fallows of *Chromolaena odorata* with and without *Gnetum lianas*, fields of food crops, forestry practices including skid trails and bare soil landings. Fractional mycorrhizal colonisation was assessed by the gridline intersect method. Spores of arbuscular mycorrhizal fungi were extracted by the wet-sieving and decanting method followed by sugar centrifugation and counted under microscope. Fruitbodies of ectomycorrhizal fungi were collected, described in fresh state, dried before microscopic examination and identification.

Due to creation of skid trails, landings and forest roads, selective logging had a very large negative impact on both ectomycorrhizae and arbuscular mycorrhizae (AM) whereas shifting cultivation had only a slight positive effect on arbuscular mycorrhizas and a negative effect on ectomycorrhizae. Both types of mycorrhizal inocula were differently partitioned: AM inoculum was continuous throughout the landscape while ectomycorrhizal inoculum was patchy, suggesting the need for different management approaches for both arbuscular mycorrhizal and ectomycorrhizal forest patches. Ectomycorrhizal forest clumps indicated least disturbed forest stands. Owing to their specific biodiversity, they should be included as indicators of sustainable forest management; Carpophores of ectomycorrhizal fungi classify as sub-indicators in the principles, criteria and indicators of African Timber Organization/International Tropical Timber Organization (ATO/ITTO)

Key words: Arbuscular mycorrhizae, Ectomycorrhizae and Land use practices

Introduction

For several decades, humid tropical forests recede following slash-and-burn agriculture and selective logging. Consequently, deforestation and land use changes have remained the major threats to biodiversity conservation of humid western African forests. At the Rio Summit in 1992, it was made clear that huge threats acted on global environment and that the immediate action should be sustainable management of

humid forests. Therefore, the promotion of criteria and indicators by many organizations for monitoring sustainable forest management began to emerge, following those developed by the International Tropical Timber Organization (ITTO) soon before the Earth summit. Later, the African Timber Organization (ATO) in collaboration with ITTO released two sets of PCI at national and forest management unit levels (Anonymous, 2003). However, these PCI did not clearly include factors that sustain growth of trees,

determine natural forest regeneration and maintain biodiversity. Sustainable functioning of tropical rain forest ecosystems depends on key ecological processes and interactions that maintain soil fertility, such as decomposition of organic matter, mineralization of nutrients, biological nitrogen fixation and mycorrhizal activities.

Mycorrhiza is the symbiotic association of the mycelium of a fungus with the roots of certain plants. It is a perennial and mutually beneficial symbiosis in which host plants derive numerous benefits, including an extended nutrients' absorbing capacity, especially for low mobile phosphorus and zinc, chiefly in soils with low nutrient availability, protection against soil pathogens, alleviation of stresses related to aluminum toxicity, heavy metals and water deficit (Newsham et al., 1995). In exchange, the mycorrhizal fungus receives simple carbon for its growth and energy in addition to a suitable habitat. A mycorrhiza is then an essential niche for plant and fungus fitness.

Two types of mycorrhizal associations have been described based on the sitting of the fungus in relation to the root surface, ectomycorrhizae (sheath-forming) with intercellular colonisation and endomycorrhizae (non sheath-forming) with intracellular colonisation. In natural and agricultural ecosystems, the predominant mycorrhizal association is arbuscular mycorrhiza. Arbuscular mycorrhizal associations differ from ectomycorrhizal ones in that they do not form mantle and cannot be seen with the naked eye. However, the two mycorrhizal types share three important components: the root itself, the fungal structures within root cells and the extraradical mycelia that explore and exploit the soil volume for nutrients and transport them to the root. In addition, ectomycorrhizal fungi also produce fruiting bodies that evidence their presence in particular habitats at humid periods of the year. This set of mycorrhizal structures constitutes mycorrhizal propagules.

However, the diversity and abundance of mycorrhizal propagules are likely to be altered by land use changes (Alexander et al., 1992; Habte, 1989; Onguene, 2000). If the alteration of mycorrhizal propagules can be readily assessed, then changes in quality and quantity of mycorrhizal propagules may determine levels of forest degradation following land use practices. The presence of particular mycorrhizal associations could also serve as indicators for sustainable forest management. The aim of this study was to assess changes in diversity and abundance of mycorrhizal associations in the humid forest of south

Cameroon after slash-and-burn agriculture and selective logging. This information was then proposed as an addendum to PCI of ATO/IITO.

Materials and methods

Site description

The study was carried out in the western portion of the Atlantic Biafrean forest of South Cameroon, lying within the Congo-Guinea refuge. The studied area is situated between the cities of Lolodorf (3°14'N, 10°44'E) in the North, Adjap-Essawo (3°02'N, 10°52'E) in the East, AkomII (2°48'N, 10°34'E) in the South and Bipindi (3°04'N, 10°25'E) in the West. The climate is hot and humid, with two distinct wet seasons from mid-March to mid-June and mid-August to mid-November. Rainfall decreases in an easterly direction, with an annual mean of 2,836 mm in Kribi to 2,096 mm in Lolodorf and 1,719 mm in Ebolowa (Waterloo et al., 2000). Average monthly temperatures vary between 23°C and 28°C. Elevation ranges from 50 m a.s.l. near Bipindi to 1,057 m a.s.l. in the Bingalanda mountain near Nyangong. The substratum consists of Precambrian metamorphic rocks and old volcanic intrusions Franqueville (1973). In the southwestern lowlands (50–350 m a.s.l.), surface soils are sandy clay loam and moderately acid; between 350 m and 500 m a.s.l., surface soils are highly clayey and strongly acid; above 500 m a.s.l., soils are very highly clayey and very strongly acid (Van Gemerden and Hazeu 1999).

Land use systems

Slash-and-burn agriculture is the main subsistence activity with plantain (*Musa AAB* L.), cocoyam (*Xanthosoma sagittifolium* (L.) Schott), groundnut (*Arachis hypogaea* L.) and cassava (*Manihot esculenta* Crantz.) as major crops. Cocoa (*Theobroma cacao* L.) is cultivated for cash revenues. The only industrial activity has recently been selective logging of mainly *Lophira alata* for about 10 to 15 years.

In the research area, four experimental sites namely Ebimimbang, Ebom, Nyangong and Bityili were selected. Rainfall data, soil physical and chemical characteristics for each are presented in Table 1. At each site, undisturbed late-successional forest stands, successional vegetation series created by shifting cultivation and selective logging were randomly selected.

Table 1. Localization, elevation, rainfall, soils characteristics and relative composition of ectomycorrhizal tree species at the four studied sites

Location	Ebimimbang	Ebom	Nyangong	Bityili
Location	3°02.67'N, 10°28.25'E	3°04.73'N, 10°41.24'E	2°58.11'N, 10°45.18'E	2°56.06'N,10°49'55E
Elevation (m)	100	440	550	800
Rainfall (mm)*	1556	1987	1677	1800
Soil types	Ultisols	Ultisols, Oxisols	Oxisols	Oxisols
Clay (%)**	10–40	40–60	60–80	60–80
pH (eau)	6.1	4.7	4.3	4.0
Carbon (%)	1.69	2.26	2.21	5.7
Nitrogen (%)	0.15	0.18	0.19	0.36
Available P (µm/ml)	0.01	0.005	0.002	0.0
Dominating ectomycorrhizal trees	Ekop**	<i>Gilbertio-dendron</i>	<i>Uapaca</i>	<i>Ekop/Uapaca/ Gilbertiodendron</i>
Stem number (%)	26	22	7	71
Contribution to BA	35	19	34	79

Notes: *Mean annual rainfall from 1994 to 2000; **Data from Gernerden & Hazeu (1999); BA = basal area and stem number in one-ha undisturbed forests at the four sites. **Ekop = generic name for a group of local Casaepl tree species.

The successional series created by shifting cultivation included early successional forest stands, fields of food crops, and fallow of *Chromolaena odorata* (L.) King & Robinson (Asteraceae). In late-successional stands both arbuscular mycorrhizal and ectomycorrhizal trees occur, the latter group often occurring in small to large clumps (Newbery et al., 1988; Onguene and Kuyper 2001). Sampling was done within and outside these ectomycorrhizal clumps. Early successional forest stands differ from late ones in being very dense due to the abundance of climbers, young saplings, juveniles and ground vegetation.

Agricultural fields are created by slashing the undergrowth vegetation and felling existing trees at the onset of the dry season, then allowing it to dry. Removal of surface debris is done by dragging large branches to field edges and burning slashed and dried vegetation in stacked piles, not over the whole field plot. Planting at the beginning of the wet seasons is done by minimum tillage with short hand hoes. Weeding by hand hoeing occurs a month after planting. Exploitation of a forest plot for subsistence production of food crops lasts two to three years. Thereafter, abandoned plots are rapidly invaded by the exotic weed *C. odorata* which forms monodominant stands that completely cover the soil surface. After fallowing for four to six years, the plots may be cleared again for cultivation or abandoned. In the later case, the land reverts to early secondary forest.

Selective logging involves felling and extraction of logs from late successional stands with wheeled skidders and crawler tractors, in 2,500 ha concessions, for one to three years. Thereafter, skid trails and landings are abandoned. Landings are slowly invaded by the early successional tree *Musanga cecropioides* (Moraceae). Most late successional stands within the research area have been selectively logged at least twice.

Assessment of mycorrhizal propagules

After enumeration of selected tree and food crop species, fractional mycorrhizal colonization was assessed after collecting fine root samples, clearing with 10% KOH, bleaching in alkaline peroxide at room temperature for 60 minutes, subsequent acidifying in 1% HCl for three minutes, staining in a solution of acid fuchsin in lactic acid and destaining (Onguene and Kuyper, 2001). Roots of food crops were collected one month after planting. Those of cocoa trees were collected in plantations of various ages, from one to 50 years old.

For the evaluation of abundance of arbuscular mycorrhizal spores in different land use systems, spore density was assessed with a modified wet and sieving decanting technique followed by water and sugar centrifugation (Onguene, 2000). Spores were

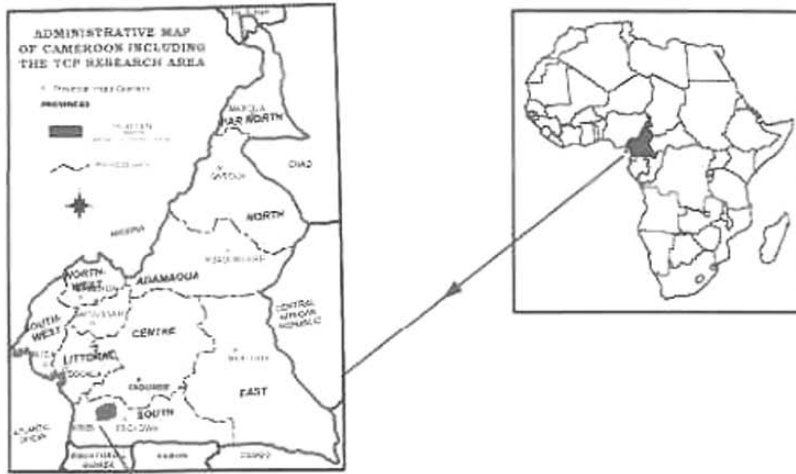
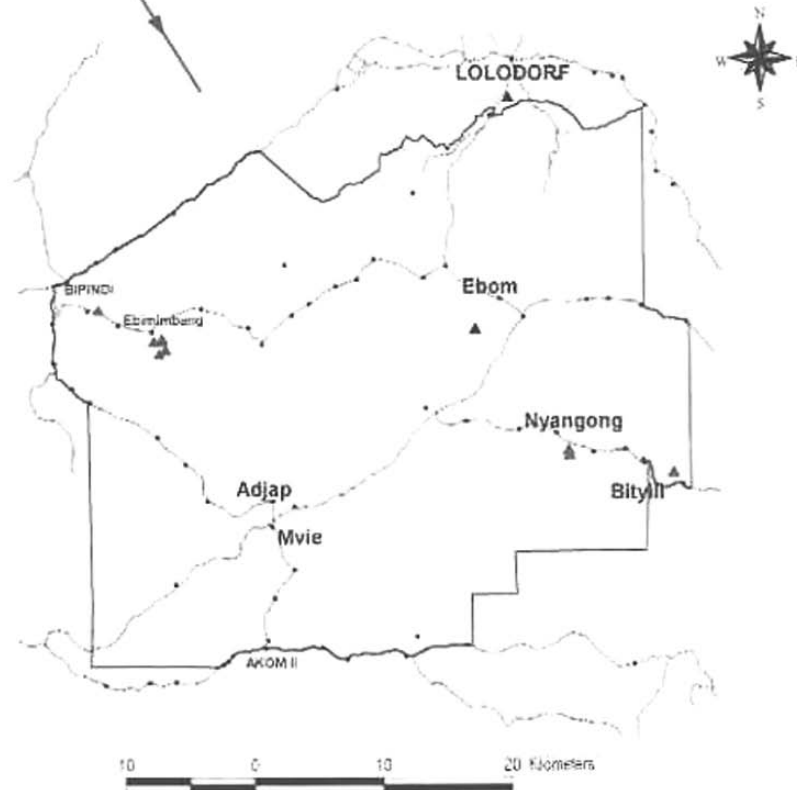

Fig 1 Localisation of the research area of the Tropenbos Cameroon Programme (TCP) with field stations and some ectomycorrhizal forest clumps



counted from 25 g of dried soil under a stereo microscope. No attempt was made to identify spores from fields.

An intact soil core bioassay was used to evaluate mycorrhizal colonisation of intact mycelia

and colonized root fragments using *Distemonanthus benthamianus* for arbuscular mycorrhizae and *Tetraberlinia bifoliolata* for ectomycorrhizae.

For three years, mushroom excursions were carried out at the four sites in permanent plots in primary

forests, inside and outside the crown projection of ectomycorrhizal forest clumps (Figure 1). Excursions took place at the two wet seasons. Collected mushrooms were described in fresh condition and subsequently dried. Exsiccates were investigated and identified in the Netherlands.

Statistical analyses

Statistical analyses were performed using the SPSS package (SPSS Inc. 1993). Data of spore numbers and percent root colonisation were tested for normality and homogeneity of variances using the Levene test. As variances were not homogeneous, spore numbers were log transformed and percent root colonisation arc sin square root transformed before a two-way analysis of variance (ANOVA) was done. Average means were separated by Duncan's multiple range tests.

Results

Two types of mycorrhizal associations were recorded at the four studied sites. Arbuscular mycorrhizal associations dominated all vegetation stands, with the exception of some old or primary forest stands where ectomycorrhizal associations became canopy dominants. In fallow of *C. odorata*, in fields of food crops and in plantations of cocoa trees, *Gnetum lianas* constituted the only ectomycorrhizal vestige. Elsewhere in the landscape, ectomycorrhizal tree species occurred in low number isolated among arbuscular mycorrhizal trees in early and late successional forest stands. Ectomycorrhizal trees occurring in isolation included *Anthonotha*, *Berlinia*, and *Uapaca* and *Afzelia* species. However, the latter species did not occur in ectomycorrhizal forest clumps.

All tree species examined formed one or the other mycorrhizal type, though to different extent. Of the 97 timber species investigated, 74 species formed only arbuscular mycorrhizal associations and 23 species formed ectomycorrhizal associations, of which five species also harbored arbuscular mycorrhizal structures (data not shown). The ectomycorrhizal habit was encountered in 13 genera and three families: *Caesalpiniaceae* (80%), *Uapacaceae* and *Gnetaceae*. Eleven genera of the *Amherstieae* and *Detarieae* in the *Caesalpiniaceae* formed ectomycorrhizal associations

with a large number of them (58%) locally called Ekop (Table 2).

Extent of mycorrhizal colonization varied with types and among trees within each mycorrhizal type. Most ectomycorrhizal trees were strongly mycotrophic, with all root tips very often colonized. Arbuscular mycorrhizal colonization varied in five mycorrhizal classes with tree species. Only tree species such as *Pterocarpus soyauxi* were strongly mycorrhizal (data not shown). All food crops and cocoa trees formed arbuscular mycorrhizal associations, but to different extent. Only roots of unnamed *Discorea* species were devoid of mycorrhizal colonization. Most food crops were of mycorrhizal class 3. All cocoa tree roots were arbuscular mycorrhizal but colonization significantly varied with age of plantation. Colonisation was notably highest and lowest on old and young plantations respectively (Table 3).

Relative abundance in stem number and basal area of ectomycorrhizal trees in late successional forest stands varied with site, from about 20% to 80%. The highest proportion of ectomycorrhizal trees was recorded in the near pristine forest in Bityili and the lowest in Ebom, with Ebimimbang and Nyangong being intermediate (Table 1). Many ectomycorrhizal forest

Table 2. Diversity of ectomycorrhizal plant families and genera in forests of south Cameroon with pilot names

Family	Genus	Pilot name	
Caesalpiniaceae	<i>Afzelia</i>	Doussie	
	<i>Anthonotha</i>	Enak	
	<i>Berlinia</i>	Ebiara	
	<i>Brachystegia</i>		Ekop naga,
			Ekop evene
	<i>Didelotia</i>	Ekop gombe	
	<i>Gilbertiendendron</i>	Abem	
	<i>Julbernadia</i>	Ekop blanc	
	<i>Monopetalanthus</i>	Ekop mayo	
	<i>Paraberlinia</i>	Ekop beli	
	<i>Tetraberlinia</i>	Ekop ribi	
	<i>Touabouate</i>	Ekop zing	
	Uapacaceae	<i>Uapaca</i>	Rikio
Gnetaceae	<i>Gnetum</i>	Okok, Eru	

Table 3. Variation in arbuscular mycorrhizal colonization of fine roots of cocoa trees in relation to age of plantation in south Cameroon

Growth stage	Seedlings	Saplings	Juvenile	Mature
Percent root colonization	15b	24b	49a	55a

clumps were recorded in Ebimimbang, Nyangong and Bityili. They were dominated in each site by a different ectomycorrhizal tree species or group of trees (Table 1).

Spore density and fractional mycorrhizal colonisation of roots of *Distemonanthus benthamianus* by indigenous arbuscular mycorrhizal fungi were significantly decreased by forestry practices (Fig. 2A and B). On the contrary, these mycorrhizal fungal propagules increased after agricultural practices with the exception of fields after burning. Spore density and fractional mycorrhizal colonisation in late and early successional forest stands were significantly lower than those obtained in agricultural systems (Fig. 2A and B).

Relative abundance of ectomycorrhizal fungal carpophores did not vary with site but with land use systems. Most putative ectomycorrhizal fruitbodies were found only in ectomycorrhizal forest clumps. Their sheer number significantly decreased in late and early successional forest stands (Fig. 2D). None was collected in disturbed land use systems with the exception of some fallows of *C. odorata* where the only ectomycorrhizal fungal fruitbody belongs to *Gnetum gasteromycete*, *Scleroderma sinnamariense*.

About 125 ectomycorrhizal fungal species were identified from the studied forest sites. Rare ectomycorrhizal species included genera of *Scleroderma*, *Cortinari*, *Inocybe*, *Clavulina* and *Coltricia*. *Amanita* species, members of the Boletales, Cantharellales and Russulales were the most abundant. The only locally edible ectomycorrhizal fungi are *Lactarius gymnocarpus* (locally called Nyumelane) and some *Cantharella* species (locally called Bingôbindong, Otsetsa, Otoyé, Nyavem).

Fruitbodies of ectomycorrhizal fungi were found mostly in clumps of ectomycorrhizal caesalps or at the stem base of *Uapaca*. Few collections were made in early and late successional forest stands. Furthermore, few collections of one gasteromycete species were obtained near *Gnetum* (Fig. 2D). Species richness matched the contribution of ectomycorrhizal trees to basal area in the forest plots. Species richness was highest in Bityili and lowest in Ebom (Table 1). However, all four sites shared a substantial number of species.

No ectomycorrhizal colonisation of roots of *Tetraberlinia bifoliolata* was detected in soils from agricultural fields, fallow of *C. odorata* without *Gnetum* species and forestry practices. But little ectomycorrhizal colonisation was recorded in fallow of *C. odorata* in the presence of *Gnetum* stumps, in early successional forest stands and more in late

Mycorrhizal associations as indicators of forest quality

Table 4. Relative abundance of putative ectomycorrhizal fungal species in forest clumps of south Cameroon

Family	Genus	Species richness
Amanitaceae	<i>Amanita</i>	30
Boletaceae	<i>Boletus</i>	4
	<i>Boletellus</i>	1
	<i>Chalciporus</i>	1
	<i>Gyrodon</i>	1
	<i>Gyropus</i>	2
	<i>Leccinum</i>	1
	<i>Phlebopus</i>	2
	<i>Phylloporus</i>	1
	<i>Pulveroboletus</i>	2
	<i>Rubinoletus</i>	1
	<i>Strobilomyces</i>	4
	<i>Tubosaeta</i>	3
<i>Tylopus</i>	1	
Cantharellaceae	<i>Cantharellus</i>	10
	<i>Craterellus</i>	2
Clavulinaceae	<i>Clavulina</i>	1
Cortinariaceae	<i>Cortinarius</i>	3
	<i>Inocybe</i>	8
Gomphaceae	<i>Gomphus</i>	1
Hymenochaetaceae	<i>Coltricia</i>	1
Russulaceae	<i>Russula</i>	30
	<i>Lactarius</i>	11
Paxillaceae	<i>Paxillus</i>	2
Sclerodermataceae	<i>Scleroderma</i>	2
Total		125

forests. The highest level of ectomycorrhizal colonisation was recorded in ectomycorrhizal forest clumps (Fig. 2C).

Discussion

Until recently, it was thought that in the tropics, mycorrhizal associations are dominated by the arbuscular mycorrhizal type while ectomycorrhizal associations are rare and occur in small to large clumps, mainly in sandy poor and heavily nutrient leached soils where they confer a competitive nutrient uptake advantage to their host plants (Alexander, 1987; Connell and Lowman, 1989).

Within the studied area, all tree and food crop species examined formed one or the other mycorrhizal type, though to different extent, viz. arbuscular mycorrhizae and ectomycorrhizae. Seventy six

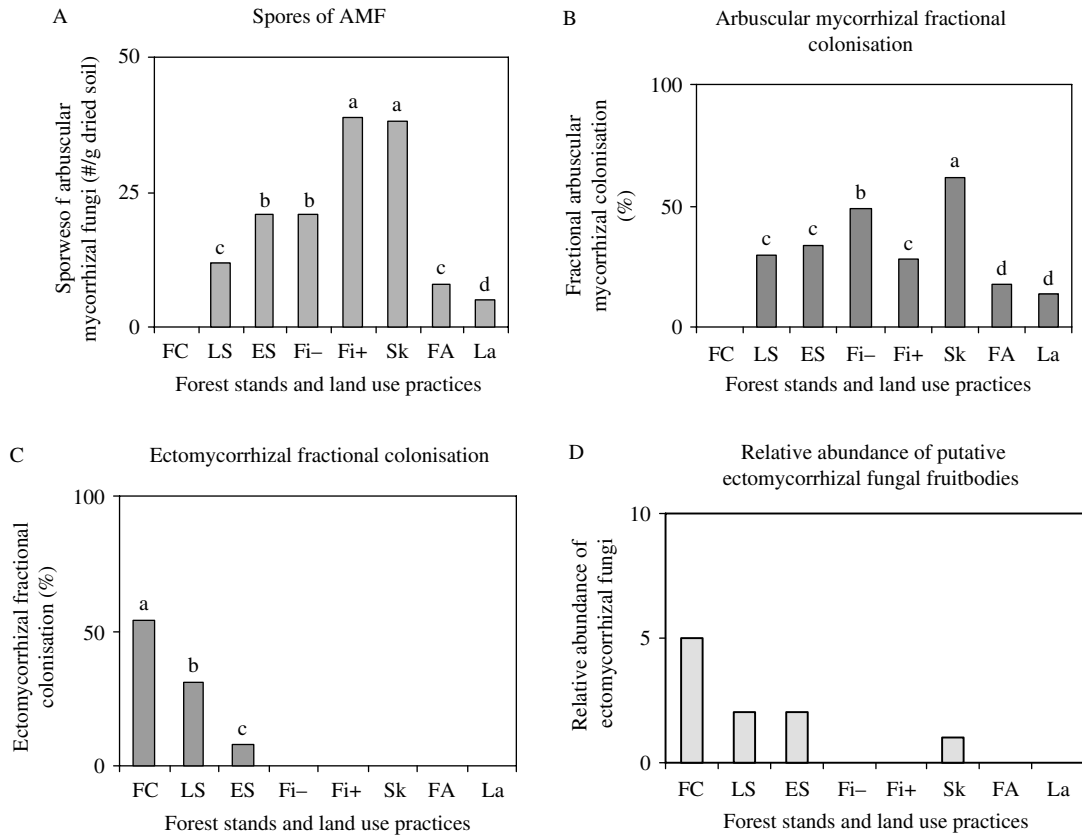

Figure 2. Effect of selective logging and shifting cultivation on various types of mycorrhizal infective propagules in forests of south Cameroon. Changes in spore number (A) and percent root colonization of arbuscular mycorrhizal fungi (B) assessed as percent root colonization of *Distemonanthus benthamianus*, percent colonization of ectomycorrhizae (C) of root tips of *Tetraberlinia bifoliolata* grown in intact soil cores and relative abundance of putative ectomycorrhizal fungal fruitbodies (D) (Average of three cores across three sites).

Notes: Means followed by the same latter in the same column are not significantly different at 5% level of significance. LS = late successional forest stands; FC = Ectomycorrhizal forest clumps; ES = early successional forest stands. FA = Fallow refers to early successional vegetation, colonized by the exotic weed *Chromolaena odorata*. Fi = Field refers to small pieces of forest lands cleared for cropping main staple foods such as groundnut, cassava and maize, before burning (Fi-) and after burning (Fi+). Sk = skid trails; La = landing. The only ectomycorrhizal fungal fruitbodies in fallow (FA) belong to *Gnetum* gasteromycete, *Scleroderma sinnamariense*.

and twenty four percentages of tree species investigated formed arbuscular mycorrhiza and ectomycorrhizae, respectively. With the exception of one yam local variety, most food and cocoa cash crops formed only arbuscular mycorrhizal associations; the only ectomycorrhizal food crop species was *Gnetum* lianas. Similar data had been recorded (Béreau *et al.* 1997; Newbery *et al.* 1988). This depicts the ubiquity of mycorrhizal associations and the predominance of arbuscular mycorrhizae in humid forests of South Cameroon.

This study has shown that ectomycorrhizal associations constitute an important proportion of the floristic composition of humid forests of South Cameroon

independent of elevation, soil type and topography (Onguene and Kuyper 2001). Similar results were also observed in forests of Korup National Park, in southwest Cameroon (Newbery *et al.* 1997). Even in late successional forest stands, ectomycorrhizal trees contribute substantially to stem number and basal area (Table 1). The ectomycorrhizal habit is also found in fallow of *Chromolaena odorata* as a relict that can serve for the regeneration of ectomycorrhizal trees in former agricultural lands.

Therefore, in the studied area, two types of mycorrhizal associations dominate. They segregate humid forest ecosystems into two forest types: arbuscular mycorrhizal forest and ectomycorrhizal forest. Both

mycorrhizal forest types substantially differed in terms of stand maturity, canopy openness, abundance and diversity of myco- and phytobiont species and extent of land use. The arbuscular mycorrhizal forest is continuous, found in open canopy of relatively young stands, poor in ectomycorrhizal fungi but rich in plant diversity, with often few isolated ectomycorrhizal species. Most activities related to slash-and-burn agriculture and selective logging occurs preferentially in arbuscular mycorrhizal forests. As a consequence, mycorrhizal diversity and abundance were negatively affected by both land use practices (Fig. 2A and 2B). Moreover, strong land use of this mycorrhizal forest type may also explain the low to moderate mycorrhizal colonisation of food crops observed in this study, even for plant species usually known as highly mycotrophic or mycorrhizal dependent plants (Plenchette *et al.* 1983; Sieverding 1991). However, when the ecosystem is less disturbed as in cocoa plantations, levels of arbuscular mycorrhizal colonisation rise again (Table 3).

In contrast, ectomycorrhizal forests appeared fragmented in landscape, in closed-canopy, climatic and relatively old stands. They were rich in fungal species and showed a narrow plant speciation. In this study, only two dozen of tree species formed ectomycorrhizae with more than a hundred of ectomycorrhizal fungal species (Tables 2 and 4). Ectomycorrhizal forest clumps constituted the only habitats for the two symbionts, trees and fungi. Both partners are interdependent; one can not survive without the other. With the exception of *Azelia* species, ectomycorrhizal trees and forests are not yet used in slash-and-burn agriculture or in selective logging. Local populations claimed that they are unsuitable for agriculture. Consequently, ectomycorrhizal forest clumps are least disturbed. In addition, information is yet available on the genesis conditions of ectomycorrhizal forest clumps, though a causal nexus has been suggested between the ectomycorrhizal habit and monodominance of caesalps (Connell and Lowman 1989).

Clumping of monodominant caesalp trees has since been known to occur in forests of the Congo basin (Fassi and Moser 1991; Letouzey 1968; Voorhoeve 1964). They have been described with *Gilbertiodendron dewevrei* (Hart *et al.* 1989; Torti *et al.* 2001; Onguene and Kuyper 2001), *Microberlinia bisicula* (Newbery *et al.* 1988, 1997), *Cynometra alexandri* (Torti and Coley 1999) and mixture of several caesalps (Onguene and Kuyper 2001). Usually, monodominant caesalps form ectomycorrhizae, obligatory and

mutually symbiosis with specific Basidiomycetes and Ascomycetes fungi. Therefore, ectomycorrhizal forest clumps should be included in criterion 3.3 of principles, criteria and indicators of ATO/ITTO as indicators not being modified by harvesting at the forest management units and the presence of carpophores of ectomycorrhizal fungi as sub-indicators.

Conclusion

Two types of mycorrhizal forests exist within the humid ecosystem of south Cameroon, namely arbuscular mycorrhizal and ectomycorrhizal forests. They differ in plant and fungal diversity and abundance as well as in extent of use. While the former lends themselves to agricultural and logging activities, ectomycorrhizal forest clumps indicated least disturbed stands. The latter are the only resort sites for African ectomycorrhizal biodiversity. The presence of ectomycorrhizal fungal sporocarps should be used as sub-indicators and ectomycorrhizal forest clumps as indicators of sustainable management of humid forests of Central Africa.

Acknowledgements

The Netherlands Organization for the Advancement of Science (NOW) provided financial support. Logistics was provided by the Tropenbos Cameroon Programme. Field assistance of Jean Baptiste Mva, Edouard Nso-moto and Serge Aba'a, and the technical assistance of Veronique Onguene are very much appreciated.

References

- Alexander I.J. 1987. Ectomycorrhizas in indigenous lowland tropical forest and woodland. 7th NACOM, Sylvia D.M., Hung L.L., Graham J.H. (eds). IFAS, Univ. Florida, Gainesville, FL, May 3–8, 1987, pp. 15–1.
- Alexander I., Ahma N. and See L.S. 1992. The role of mycorrhizas in the regeneration of some Malaysian forest trees. *Phil. Trans. R. Soc. Lond.*, ser. B 335: 379–388.
- Anonymous, 2003: ATO/IITO Principles, criteria and indicators for the sustainable management of natural tropical forests. IITO Policy Development Series n°14, Yokohama, Japon.
- Béreau M., Gazel M. and Garbaye J. 1997. Les symbioses mycorrhiziennes des arbres de la forêt tropicale humide de Guyane française. *Can. J. Bot.* 75: 711–716.
- Connell J.H. and Lowman M. 1989. Low-diversity tropical rain forests: some possible mechanisms for their existence. *Am. Nat.* 134: 88–119.

- Fassi B. and Moser M. 1991. Mycorrhizae in the natural forest of tropical Africa and the Neotropics. In: Fontana A. (ed.), *Funghi, Piante e Suolo*, Centro di studio Micologia del Consiglio nazionale delle Ricerche, Torino, Italy, pp. 183–202.
- Franqueville A. 1973. Atlas régional sud-ouest. République Unie du Cameroun. ORSTOM, Yaoundé, Cameroun
- Habte M. 1989. Impact of simulated erosion on the abundance and activity of indigenous vesicular-arbuscular mycorrhizal endophytes in an oxisol. *Biol.Fertil. Soils*. 7: 164–167.
- Hart T.B., Hart J.A. and Murphy P.H. 1989. Mono-dominant and species-rich forests of the humid tropics: causes for their occurrence. *Am. Nat.* 133: 613–633.
- Letouzey R. 1968. Etude phytogéographique du Cameroun. Ed. P. Le Chevalier, Paris.
- Newbery D.M., Alexander I.J., Thomas D.W. and Gartlan J.S. 1988. Ectomycorrhizal rain forest legumes and soil phosphorus in Korup National Park, Cameroon, *New Phytol.* 109: 367–409.
- Newbery D.M., Alexander I.J. and Gartlan J.S. 1997. Phosphorus dynamics in lowland African rain forest: the influence of ectomycorrhizal trees. *Ecological Monographs* 67(3): 367–409.
- Newsham K.K., Fitter A.H. and Watkinson A.R. 1995. Multifunctionality and biodiversity in arbuscular mycorrhizas. *Trends Ecol. Evol.* 10: 407–411.
- Onguene N.A. 2000. Mycorrhizal diversity and dynamics in south Cameroon.
- Onguene N.A. and Kuyper T.H.W. 2001. Mycorrhizal associations in rain forest of south Cameroon. *For. Ecol.Manag.* 140: 277–287.
- Plenchette C., Fortin J.A. and Furlan V. 1983. Growth response of several plant species to mycorrhizae in a soil of moderate P- fertility. II. Soil fumigation induced stunting of plants corrected by reintroduction of the wild endomycorrhizal flora. *Plant and Soil* 70: 211–217.
- Sieverding E. 1991. Vesicular-arbuscular mycorrhiza management in tropical agrosystems. Eschborn, Deutsche Gesellschaft für Technische Zusammenarbeit (GTZ) GmbH.
- SPSS Inc. 1993. *SPSS – X users'Guide*. 4th ed. Gorinchem, the Netherlands.
- Torti S.D. and Coley P.D. 1999. Tropical monodominance: a preliminary test of the ectomycorrhizal hypothesis. *Biotropica* 31: 220–228.
- Torti S.D., Coley P.D. and Kursar T.A. 2001. Causes and consequences of monodominance in tropical lowland forest. *Am. Nat.* 157:141–153.
- Voorhoeve A.G. 1964. Some notes on the tropical rainforest of the Yoma-Gola national forest near Bomi Hills, Liberia. *Commonw. For. Rev.* 43: 17–24.
- Van Gemerden B.S. and Hazeu G.W. 1999. Landscape ecological survey (1:100 000) of the Bipindi-AkomII-Lolodorf region, Southwest Cameroon. *Tropenbos Documents* 1: 1–164.
- Waterloo M.J., Ntonga J.C., Dolman A.J. and Ayangma A.B. 2000. Impact of land use change on the hydrology and erosion of rain forest land in South Cameroon. DLO Winand Staring Centre Report 134: 1–89.

Biomass production, N and P uptake of *Mucuna* after Bradyrhizobia and Arbuscular mycorrhizal fungi inoculation, and P-application on acid soil of Southern Cameroon

Jemo M.^{1*}, Nolte C.¹ and Nwaga D.²

¹International Institute of Tropical Agriculture, Humid Forest Ecoregional Centre, BP 2008 (Messa) Yaoundé Cameroon; ²Laboratory of Soil Microbiology, Biotechnology Centre and Department of Plant Biology, P.O. Box 812, Yaoundé, Cameroon; E-mail: dwaga@yahoo.fr * Author for correspondence: International Institute of Tropical Agriculture, Cameroon, BP 2008 (Messa) Yaoundé, Tel 237–2237434, Fax 237–2237437, Email: mjemo@cgiar.org

Abstract

Herbaceous legumes such as *Mucuna* have the potential to provide large amounts of N to a subsequent cereal and thereby replace some of the fertilizer N required for high grain yield. However, not in all fields can *Mucuna* actually fix sufficient N as it has been shown. This is generally attributed to the lack of appropriate rhizobia strains nodulating with *Mucuna* or to low nutrient availability, particularly phosphorus (P). *Mucuna pruriens* var. *veracruz* was grown in 1998 and 2000 in a factorial experiment with three factors. Each of the three factors, i.e. rhizobia inoculation (R+/R–), mycorrhizal inoculation (M+/M–) and phosphorus (P) fertilization (P+/P–), had two levels that were combined to give treatments. Biomass production, N and P uptake of *Mucuna* were measured. The biomass production of *Mucuna* was significantly higher in inoculated (R+) vs. uninoculated (R–) plants, with consistent results over both years. The effect of AMF inoculation and P application on biomass production was not significant. The P uptake of R+ plants was significantly higher than that of R– plants. The specific P uptake of *Mucuna* was significantly improved with AMF inoculation in 2000, but not in 1998. The P-utilization efficiency was significantly higher in shoots of plants inoculated with AMF application than in uninoculated ones. Total N uptake ranged from 206 to 314 kg N ha⁻¹ for un-inoculated and inoculated *Mucuna* plants, respectively. Results clearly indicated that inoculation with appropriate rhizobia could help in increasing *Mucuna* biomass and N uptake in acid, infertile soils such as those encountered in the humid forest zone of southern Cameroon

Key words: humid forest zone soils; soil constraints; planted short-fallows; herbaceous leguminous crops; – P utilization efficiency

Introduction

Mucuna spp. (*Mucuna*) is one of the most widely tested herbaceous legumes in West and Central Africa (WCA), and is currently promoted in sustainable agriculture. Significant benefits to maize and banana succeeding a *Mucuna* fallow have been reported for the humid zone in WCA (Vine 1953; Giller and Wilson 1991; Carsky et al. 1998, 2001; Häuser et al.

2002; Häuser and Nolte 2002). Its positive effects are principally related to its ability to fix atmospheric N, to accumulate significant amounts of biomass, and to suppress weeds (Carsky et al. 1998). However, depending on the soil, the proportion of N₂ fixed by *Mucuna* varies widely, ranging from 83% in fertile to 63% in infertile acid soils (Becker and Johnson 1997). Such variability indicates that growth and N fixation of *Mucuna* may be profoundly influenced by biotic factors, e.g., lack of

effective rhizobia strains or root infection by arbuscular mycorrhizal fungi (AMF). Abiotic factors, particularly soil acidity and P availability are also important (Giller and Wilson 1991; Sanginga et al. 1996; Houngnandan et al. 2000, 2001). Soils of southern Cameroon are predominantly Ultisols and Oxisols, characterized by low to very low available P with acid to very acid conditions (Holland et al. 1992). The real implication is that farmers growing *Mucuna* are not exploiting optimum benefits from the legume as N source and weed suppressor in the long run. Research is needed to improve the agronomic potentials of *Mucuna* in marginal and infertile soils of the humid forest zone of Southern Cameroon. Inorganic fertilizer could be used in combination with a short *Mucuna* fallow so as to improve the yield of a succeeding crop. However, mineral fertilizers are not available to humid forest zone farmers at affordable prices. Therefore, biological means of improving *Mucuna* fallows, such as rhizobial and AMF inoculation, may be an attractive and practicable alternative.

Inoculation of legumes with suitable rhizobia and AMF have been reported elsewhere to significantly improve biomass production, N and P-uptake in nutrient-poor soils such as those encountered in Southern Cameroon (Bagayoko et al. 2000; Houngnandan et al. 2001). AMF fungi are known to play an important role in the uptake of immobile nutrients, such as P, Zn and Cu, which is of particular importance for soils constrained by those nutrients (Bagyaraj 1984; Bolan 1991). Suitable management of AMF practices may have a significant effect on growth and N and P accumulation of *Mucuna pruriens* var. *veracruz* in the WCA of southern Cameroon.

Inoculating with suitable rhizobia strains can be a key factor for accelerating N₂ fixation and enhancing the survival and growth of *M. pruriens* in marginal soils. In comparison with the amount of work done on soils in West Africa (Sanginga et al. 1996; Houngnandan et al. 2000, 2001), little information is available on the potential of soil microorganisms on nutrient availability and crop growth in acid soils of Southern Cameroon (Nwaga 1997). It is well known that P and N availability severely limit crop growth in many of these soils (Sanchez and Salinas 1981), exploitation of the bradrhizobial and AMF symbiosis can help to improve the growth and nutrient acquisition of *Mucuna* in marginal and infertile soils. This work was undertaken to examine whether growth and nutrient uptake of *M. veracruz* may benefit from artificial rhizobial and AMF inoculants in an acid soil.

Materials and methods

Site selection

The experiment was carried out at the Minkoameyos experimental station (3° 51N, 11° 25E) of the Institut de Recherche Agricole pour le Développement (IRAD). The soil is an isohyperthermic, Typic Kandudult (Ambassa-Kiki 1990), major properties are presented in Table 1. The long-term mean annual rainfall of the site is 1,643 mm with a bimodal distribution. In an average year the first rainy season starts in mid-March and lasts until end of June, followed by a short dry season until mid-August. The major rainy season starts in mid-August and lasts until mid to end November. Rainfall was 1,488 mm in 1998 and 1,404 in 2000.

Field establishment and experimental design

The experiment was established in a field that had a sole maize crop in 1997 followed by a short fallow of eight months. The fallow vegetation was dominated by *Chromolaena odorata* (L.) R.M. King and H. Robinson (*chromolaena*) (>50%) and *Asconopus compressus*. After the *Mucuna* fallow in 1998, sole maize was grown in 1999, followed by an 8-months short fallow with natural vegetation that preceded *Mucuna* in 2000.

Mucuna was sown into 3 by 3 m plots at 0.5 by 0.5 m with two seeds per hill on 15th April 1998 and 14th April 2000. The experimental design was a factorial randomized complete block design (RCB) with

Table 1. Soils physical and chemical characteristics at the establishment of the trial in April 1998 at Minkoameyos, Cameroon

Soil depth (cm)	0–5	5–10	10–25
Bulk density	1.06	1.28	1.24
Sand (g.kg ⁻¹)	545.2	515.2	455.2
Clay (g.kg ⁻¹)	292.2	332	392
Silt (g.kg ⁻¹)	162.8	152.8	152.8
pH (H ₂ O)	5.88	5.23	4.99
Available P (g.kg ⁻¹)	5.09	2.09	0.74
Total N (g.kg ⁻¹)	2.01	1.30	0.87
Total carbon (g.kg ⁻¹)	56.78	10.11	7.94
C/N ratio	12.20	11.32	9.26
K (cmol (+)/kg)	0.10	0.06	0.05
Ca (cmol (+)/kg)	5.06	3.04	1.04
Mg (cmol(+)/kg)	2.44	1.37	0.04
Al (cmol/kg)	0.03	0.02	0.04

three factors: factor 1: with and without rhizobial inoculation (R+/R-); factor 2: with and without arbuscular mycorrhizal inoculation (M+/M-); factor 3: with and without P application at a rate of 30 kg P ha⁻¹ (P+/P-). P was applied as Triple Super Phosphate (TSP) at a rate of 30 kg P ha⁻¹. The first application was done one day before sowing, the second application two weeks after planting (WAP). Each of the eight treatments was replicated four times.

Rhizobial inoculation

The rhizobial inoculum consisted of mixed strains that were isolated from nodules of cowpea (*Vigna unguiculata*), Bambara groundnut (*Voandzeia subterranea*), and soybean (*Glycine max*), grown in different localities of southern Cameroon. The *Mucuna* seeds were mixed with a peat substrate, containing the following rhizobial strains: VU1D1, VUXY1, VSXY1, GMXC (Nwaga and Ngo Nkot 1998). Each grain of *Mucuna* was coated according to Vincent (1970), with 33 mg of inoculants at a rhizobial population density of approximately 10⁸ cells g⁻¹ of inoculum, immediately before sowing.

Mycorrhizal inoculation and assessment of the root colonization

Root segments of millet (*Penisetum americanum*), chopped into 0.5–1 cm pieces and infected with spores of *Glomus deserticola* and *Gigaspora sp.*, were used for the inoculation of *Mucuna* seeds with arbuscular mycorrhizal fungi (AMF). In addition, 10 g of soil, containing approximately five spores of the same fungi species, were placed into the seed hole before planting. The AMF strains are part of the microbial isolated from resource bank of the Biotechnology Centre, University of Yaoundé I. Diverses sites in Cameroon (Ngonkeu, 2003; Nwaga et al., 2004) were screened in previous greenhouse and field experiments. Complete root systems of *Mucuna* were collected at flowering (pod filling) in order to analyze AMF root colonization. The sampled roots from the field were placed into vials containing 50% alcohol until processed. Roots were washed free of soil and stored at 4°C prior to laboratory analysis. Roots were later thawed and 1 g of the fresh roots was cut into 1 cm length pieces and cleared in KOH solution. The cut roots were stained with acid fuchsin in lactoglycerin at room temperature according to Phillips and

Hayman (1970) and Merryweather and Fitter (1991) which gave best results. The stained roots were then examined for root colonization by AMF with the grid-line intersects method of Giovannetti and Mosse (1980) using a stereomicroscope at 40x magnification.

Soil and plant sampling for laboratory analyses

Five core samples of soil for each depth (0–5, 5–10, 10–25 cm) were taken with a 100 cm³ cylinder in each pot. Composite samples for each depth were then obtained by bulking the five samples for the pot. The soils were air dried and sieved to 2 mm mesh for physical and chemical analyses.

The bulk density of the soil was determined in 100 cm³ volume of soil sample. The sample was oven dried at 110°C for 72 h for dry weight determination. The bulk density was then calculated using the following formula:

$$\text{Bulk density} = \frac{\text{dry weight}}{\text{volume}} \quad (1)$$

Basic cations were extracted in Mehlich-3 extractant 1:10 ratio and analyzed using atomic absorption spectrophotometer, and data are reported as cmol (+)/kg. Organic Carbon was analyzed using Heanes improved chromic digestion and spectrophotometry procedure and reported as percentage (%). Soil pH was determined in water suspension at a 2.5-soil/water ratio. Available P was extracted by the Mehlich-3 procedure (Mehlich 1984). Total soil N was determined using the Kjeldahl method for digestion and ammonium electrode determination (Bremner and Tabatabai 1972; Bremner and Mulvaney 1982).

Mucuna shoots litter and roots were sampled at 14 and 20 Weeks after planting (WAP) using a 1 m by 1 m. quadrat. The harvested shoot and litter biomass was oven dried at 70°C for 72 hours. Roots were preserved in plastic bags prior to cleaning them with tap water. The nodules were detached from fresh roots in the field, counted and their number and fresh weight were recorded. They were later put into the oven at 70°C for 72 hours for dry weight determination.

Shoot, litter and root samples were grinded to 0.5 mm and then digested according to Novozamsky et al. (1983). Total N and P in plants were respectively determined with an ammonium sensitive electrode (Powers et al. 1981) and a malachite free colorimetric method (Motomizu et al. 1983).

The average specific P uptake (SPU), expressed as total P uptake (mg P) per gram of dry root mass was calculated as shown in Equation 1:

$$\text{SPU} = \frac{\text{Total Pin plant(mg)}}{\text{Root dry weight(g)}} \quad (2)$$

The percentage P utilization efficiency (PUE), expressed as the percentage increase in P uptake (either by roots or by shoots) was calculated as shown in Equation 2 (Reference):

$$\text{PUE} = \frac{P_m - P_{nm}}{P_{nm}} * 100 \quad (3)$$

Where P_m and P_{nm} are P uptake in plant with and without AMF inoculation

Statistic analysis

An ANOVA was carried out using PROC GLM¹ of SAS for the analysis of treatment effects and their interactions. The Tukey test was used for means comparison only if the F-test showed significant treatment effects. Pearson's correlation analyses were also used to establish relationships between nodule Dry Matter (DM), total biomass and P-uptake and nodule number.

Results

Response of M. pruriens to rhizobial and AMF inoculation, and P application

The number of nodules and total dry matter (DM) of *M. pruriens* was significantly higher in inoculated (R+) than in un-inoculated (R-) plants in both years (Table 2). P application as well as mycorrhizal inoculation significantly increased the number of nodules in 2000 but not in 1998. Nodule DM in M+ and P+ plants were significantly higher compared to that of M- and P- plants, respectively. The F-test denoted that R x M interaction was significant for nodule dry matter production ($P = 0.02$). Nodule DM significantly increased when rhizobial inoculation and P fertilizer application were combined. The presence of nodules in control plants indicated the availability of indigenous and infective rhizobial strains, although they were less efficient. The nodule DM positively correlated with total biomass ($r = 0.42$, $P < 0.05$), total P-uptake ($r = 0.50$,

$P < 0.02$) and nodule number per plant ($r = 0.53$, $P < 0.05$).

The percentage of root colonization by AMF was significantly higher in M+ compared with M-plants (Table 2) for both years. P application as well as rhizobial inoculation did not significantly increase the percentage of root colonization by AMF ($P = 0.04$). However, the overall levels of AMF root infection were low, ranging from 8 to 30%.

Biomass dry matter production

Root, litter and shoot DM of plants inoculated with rhizobium (R+) were significantly higher ($P = 0.002$) than those of un-inoculated (R-) plants (Table 3). The differences were consistent over both years. The shoot/root ratio of R+ plants was significantly higher than that of uninoculated plants in 1998 and 2000. Plants inoculated with AMF (M+) had significantly higher DM in roots, litter, shoots and shoot/root ratio in 2000, but not in 1998. P application significantly increased litter and shoot of *Mucuna* in 1998 whereas in 2000 root and shoot DM was significantly higher in plants that had received TSP. The shoot/root ratio was significantly higher in P+ plants in 1988 and 2000. The interaction R x M was significant for the shoot DM yield provide the trends. Significant correlations were found between the litter DM and total P-uptake ($r = 0.73$, $P < 0.001$).

P and N uptake of Mucuna

P accumulation in shoots and litter of R+ plants was significantly higher as compared to R- plants in 1998 and 2000 (Table 4). Root-P accumulation was significantly higher in R+ than R- in 1998, but not in 2000. Similarly to the increase in DM of all components (Table 3), AMF inoculation (M+) increased P accumulation in the litter and shoot DM in 1998 and in 2000. Application of 30 kg ha⁻¹ TSP significantly increased P accumulation in the litter of P+ plants in 1998 and 2000. P application also increased the P accumulation in shoots in 1998, but not in 2000. The P-uptake efficiency of M+ plants was significantly higher than that of M- plants in 2000, but not in 1998 (Table 4).

The relative P-utilization efficiency (relative P uptake of inoculated vs. uninoculated plants) in shoots was significantly higher in M+ plants than in P+ -plants in both years (Figure 1). The PUE in roots

Table 2. Effect of rhizobial and AMF inoculation on nodulation and Arbuscular mycorrhizal colonization of *M. pruriens* in 1988 and 2000 at Minkoameyos (Southern Cameroon)

Main effect	Nodule number		Nodule dry weight [g.plant ⁻¹]		Arbuscular mycorrhizal root colonization [%]
	1998	2000	1998	2000	2000
R+	7.37 ^a	10.35 ^a	1.02 ^a	1.13 ^a	14.11 ^a
R-	4.88 ^b	6.94 ^b	0.46 ^b	0.66 ^b	13.46 ^a
P+	7.68 ^a	9.28 ^a	1.04 ^a	1.10 ^a	12.81 ^a
P-	4.41 ^a	6.45 ^b	0.51 ^b	0.70 ^b	13.73 ^a
M+	6.86 ^a	10.86 ^a	0.88 ^a	1.06 ^a	15.04 ^a
M-	5.44 ^a	6.48 ^b	0.38 ^b	0.61 ^b	10.86 ^b
<i>F value</i>					
Rhizobium (R)	2.54*		2.04*		ns
Phosphorus (P)	11.63**		4.56*		ns
Mycorrhizal (M)	Ns		ns		2.76*
R*P	Ns		ns		ns
R*M	Ns		2.02*		ns
P*M	ns		ns		ns
R*P*M	ns		ns		ns

Note: R1: inoculation with rhizobia; M1: inoculated with mycorrhizal; P1: P-fertilizer application (30 kg P ha⁻¹) a,b, means in the same columns followed with the same letter are not significantly different at $P < 0.05$. ns, not significant, * significant at $P < 0.05$, ** significant at $P < 0.001$.

Table 3. Biomass production of *M. pruriens* with or without seed inoculation by rhizobia, arbuscular mycorrhizal and P application at Minkoameyos in 1998 and 2000, Cameroon

Main effect	Root DM		Litter DM		Shoot DM		Shoot /root ratio	
	[ton.ha ⁻¹]						[dwt.dwt ⁻¹]	
	1998	2000	1998	2000	1998	2000	1998	2000
R+	0.12 ^a	0.14 ^a	2.85 ^a	5.96 ^a	3.27 ^a	5.24 ^a	85.5 ^a	88.8 ^a
R-	0.08 ^b	0.12 ^b	2.25 ^b	4.30 ^b	2.27 ^b	4.61 ^b	53.7 ^b	61.5 ^b
P+	0.10 ^a	0.14 ^a	2.72 ^a	5.42 ^a	2.98 ^a	5.19 ^a	83.8 ^a	88.6 ^a
P-	0.09 ^a	0.12 ^b	2.38 ^b	4.87 ^a	2.43 ^b	4.43 ^b	47.5 ^b	66.4 ^b
M+	0.10 ^a	0.15 ^a	2.54 ^b	5.73 ^a	2.89 ^a	4.80 ^a	68.7 ^a	91.3 ^a
M-	0.09 ^a	0.12 ^b	2.30 ^b	4.44 ^b	2.45 ^a	4.05 ^b	46.7 ^b	66.4 ^b
<i>F-value</i>								
Rhizobium (R)	1.95*		4.64 *		11.662**		7.98*	
Phosphorus (P)	2.66 *		ns		3.22 *		6.19*	
Mycorrhizal (M)	Ns		ns		ns		ns	
R*P	Ns		ns		ns		ns	
R*M	Ns		ns		9.14**		ns	
P*M	Ns		ns		ns		ns	
R*P*M	ns		ns		ns		ns	

Note: R+: inoculation with rhizobia; M+: inoculated with mycorrhizal; P+: P-fertilizer application (30 kg P ha⁻¹), a, b, means in the same columns followed with the same letter are not significantly different at $P < 0.05$. ns, not significant, * significant at $P < 0.05$, ** significant at $P < 0.001$.

Table 4. Effect of inoculation with rhizobia and AMF, and P application on P accumulation and specific P uptake of *Mucuna* at Minkoameyos in 1998 and 2000, Cameroon

Main effect	Root P uptake		Litter P uptake		Shoot P uptake		SPU ¹	
	[kgP.ha ⁻¹]						[mgP.g ⁻¹ dry weight root]	
	1998	2000	1998	2000	1998	2000	1998	2000
R+	0.15 ^b	0.21 ^b	6.89 ^a	8.79 ^a	6.15 ^a	11.43 ^a	119.6 ^a	156.4 ^a
R-	0.08 ^b	0.18 ^a	3.72 ^b	6.77 ^b	4.53 ^b	9.08 ^b	92.4 ^a	124.0 ^a
P+	0.13 ^a	0.20 ^a	6.11 ^a	9.68 ^a	5.94 ^a	10.51 ^a	122.9 ^a	164.2 ^a
P-	0.11 ^a	0.15 ^b	4.43 ^b	6.75 ^b	4.43 ^b	8.88 ^a	89.0 ^a	127.3 ^a
M+	0.13 ^a	0.23 ^a	6.04 ^a	9.31 ^a	5.50 ^a	10.45 ^a	107.1 ^a	172.1 ^a
M-	0.10 ^a	0.16 ^b	4.19 ^b	5.98 ^b	3.60 ^b	8.31 ^b	79.8 ^a	127.9 ^b
<i>F-value</i>								
Rhizobium (R)	3.44 *		7.85**		ns		ns	
Phosphorus (P)	ns		ns		2.18*		ns	
Mycorrhizal (M)	ns		10.58 **		3.39*		ns	
R*P	ns		ns		ns		ns	
R*M	ns		ns		ns		ns	
P*M	ns		ns		ns		7.94*	
R*P*M	ns		ns		ns		ns	

Note: R+: inoculation with rhizobia; M+: inoculated with mycorrhizal; P+: P-fertilizer application (30 kgP.ha⁻¹), a,b, means in the same columns followed with the same letter are not significantly different at $P < 0.05$. ns, not significant, * significant at $P < 0.05$, ** significant at $P < 0.001$. ¹Specific P uptake (mg P.g⁻¹.root dry weight).

significantly increased by AMF inoculation in 1998, but not in 2000.

Total N accumulation ranged from 206 kg N ha⁻¹ in R-plants to 314 kg N ha⁻¹ in R+ plants and from 210 kg N ha⁻¹ in P-plants to 288 kg N ha⁻¹ in P+ plants. It ranged from 198 kg N ha⁻¹ in M- plants to 283 kg N ha⁻¹ in M+ plants (Figure 2).

Discussion

Total N accumulation as well as nodule formation is a sensitive indicator of rhizobial effectivity of symbiosis. In this study, total N in plants was significantly increased with rhizobial inoculation, which shows that the selected strains used were efficient enough to form nodules and to increase N fixation from the atmosphere in this acidic soil. The consistency of the results over both years indicates that indigenous rhizobia populations, present in this acid soil, were less efficient to nodulate (infect) *Mucuna* roots than acidity selected strains in the inoculum. Estimates for N-fixation of *Mucuna*, using the difference method and made in on-station trials at Mbalmayo, indicated a total amount of

147 to 222 kg N ha⁻¹. Plants had been sampled at 12 WAP and no fertilizer or inocula were used (Häuser and Nolte 2002). The amount of N accumulated by *Mucuna* in the present study ranged from 206 to 314 kg N ha⁻¹ for R+, which represents an increase of 52%. However, soils and rainfall at Mbalmayo are slightly different. Nevertheless, this suggests that, without P-fertilizer application nor rhizobial inoculation, *Mucuna* did not reach its N-fixation potential. One of the major limiting factors to N fixation was the low P level in the soil, in our trial we observed that *Mucuna* significantly responded to P application. The significant increase in N to P application indicated might indicate the importance of P application for optimal N₂ fixation in *Mucuna*. Similar findings were observed by Giller and Wilson (1991), Sanginga et al. (1996) and Hounnandan et al. (2000).

Under P-deficient soil conditions, AMF root colonization has been found to improve the P-uptake of plant (Smith and Read 1997). The increased uptake efficiency after AMF inoculation is mainly due to the enhancement of the total root surface area, which increases the absorption of P in the roots and its translocation to the host. The

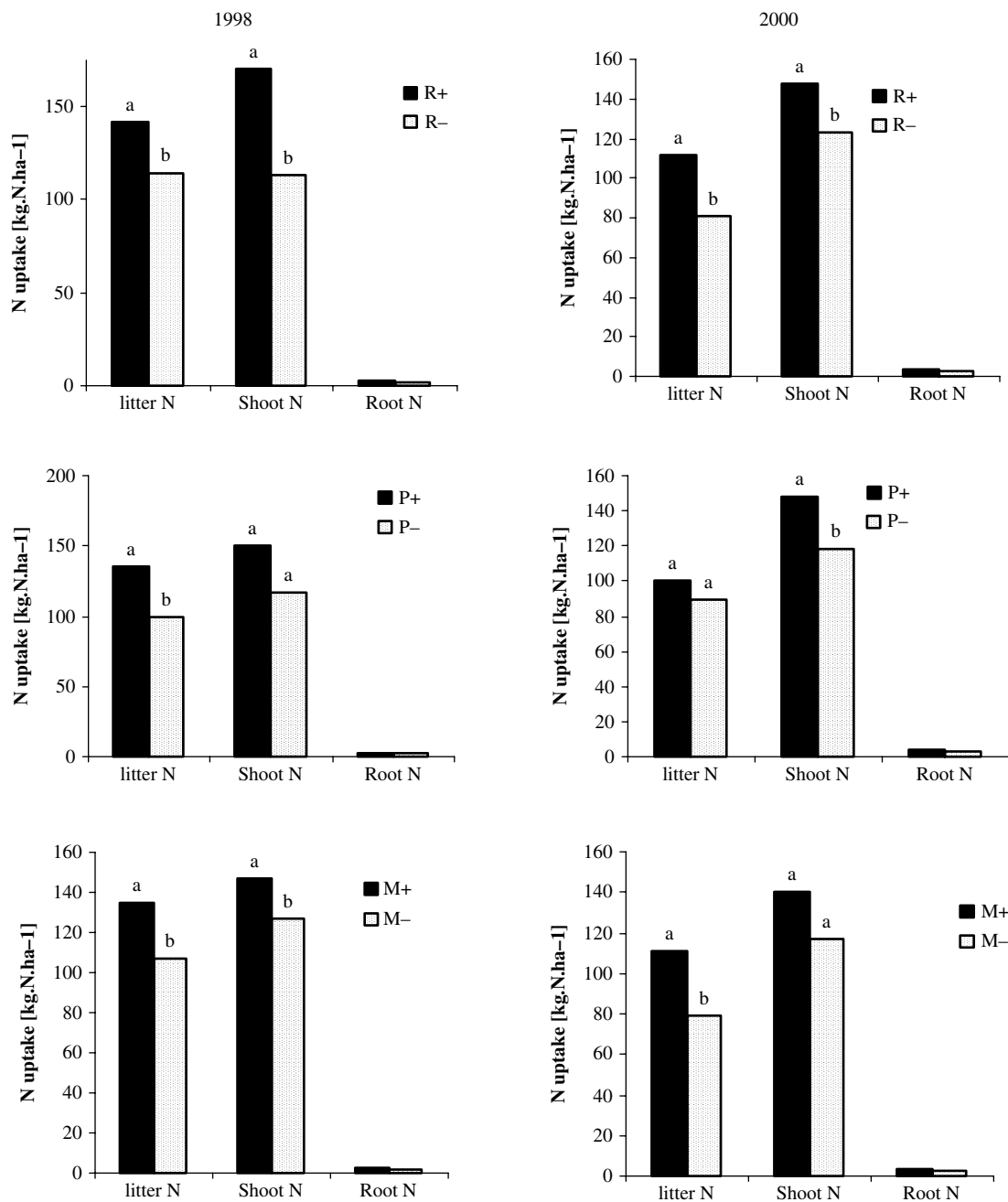

R+, with rhizobia; R-, without rhizobia; P+, with P application (TSP=30 kg.P.ha⁻¹); P-, without P application; M+, mycorrhizal inoculation; M-, without AMF inoculation

Figure 1. N-uptake in different plant organs of *Mucuna* inoculated or uninoculated with rhizobial, arbuscular mycorrhizal or treated with fertiliser-P in 1998 and 2000, at Minkoameyos site (southern Cameroon).

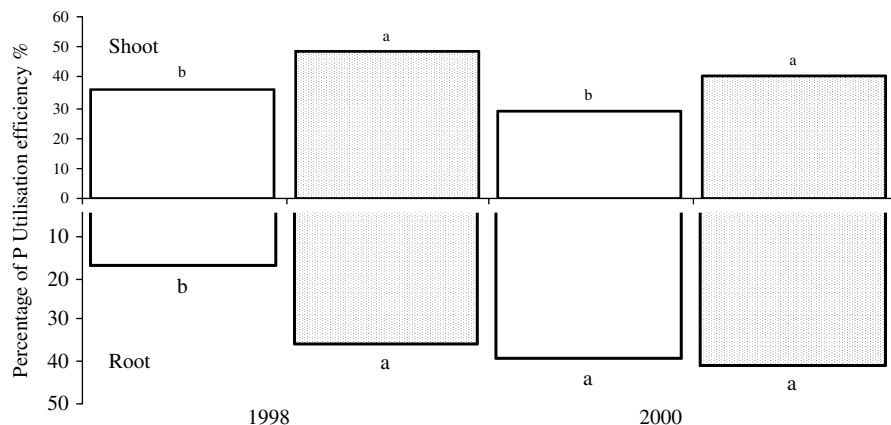

Figure 2. Percentage P utilisation (relative P uptake of inoculated vs uninoculated plants of *M. veracruz* in shoots and root, as influenced by P application (open columns) and arbuscular mycorrhizal inoculation (dotted columns) in 1998 and 2000. Column indexed with the same letter are not significantly different at $P < 0.05$.

present study did not show a clear effect of AMF inoculation in most of the parameters studied. This could be due a too low AMF population in the inoculum. In acidic soil, AMF inoculation using more concentrate inoculum, a significant yield increase of maize was noticed (Nwaga et al., 2004).

Conclusions

Improved N and P uptake by legumes directly benefit crops in extensive cropping systems in developing countries, where access to fertilizer farmers is limited. Our results have two major impacts: first, inoculation of mucuna seeds with selected rhizobia may significantly increase N_2 fixation and biomass, but it may be necessary to further select rhizobia specifically adapted to *Mucuna* on acid soils. Secondly, persistence of introduced rhizobia and/or AMF in the soil is important, but often a problem. It is usually expected that introduced rhizobia and fungi dominate the indigenous strains and that the introduced will become more active in subsequent years and better adapted to survive in the humid forest soil environment.

References

- Ambassa-Kiki R. 1990. Un site d'expérimentation du réseau IBSRAM à Minkoameyos, Yaoundé. *IBSRAM Proceedings* 10: 425–440.
- Bagayoko M., George E., Römheld V. and Buerkert A. 2000. Effects of mycorrhizae and phosphorus on growth and nutrient uptake of millet, cowpea and sorghum on West African soil. *Journal of Agricultural Science* 135: 399–407.
- Bagyaraj D.J. 1984. Biological interactions with VA mycorrhizal fungi. In: Conway L.I., Powell C.L. and Bagyaraj D.J. (Eds). *VA-mycorrhizae*. Boca Raton, FL, USA: CRC Press, pp. 132±153.
- Becker M. and Johnson D. 1997. The role of legume fallows in intensified upland rice-based system of West Africa. *Nutr. Cycl. Agroecosystem* 53: 71–81.
- Bolan N.S. 1991. A critical review of the role of the mycorrhizal fungi in the uptake of phosphorus by plant. *Plant and Soil* 134: 189–207.
- Bremner J.M. and Mulvaney C.S. 1982. Total nitrogen. In: Page A.L., Miller R.H. and Keeney D.R. (Ed.). *Methods of Soil Analysis Part 2*. American Society of Agronomy; Madison, U.S.A., pp. 595–622.
- Bremner J.M. and Tabatabai M.A. 1972. Uses of an ammonia electrode for determination of ammonium in Kjeldahl analysis of soil. *Communication in Soil Science and Plant Analysis* 3: 71–80.
- Carsky R.J., Becker M. and Hauser S. 2001. *Mucuna* cover crop fallow systems: Potential and limitations. In: Carsky et al. (Eds). *Sustaining soil fertility in West Africa*. SSSA Special Publication No. 58, pp. 111–135
- Carsky R.J., Tarawali S.A., Becker M., Chikoye D., Tian G. and Sanginga N. 1998. *Mucuna*-herbaceous cover legume with potential for multiple use. Resources and Crop Management Research Monograph vol. 25. International Institute of Tropical Agriculture; Ibadan, Nigeria.
- Giller K.E. and Wilson K.J. 1991. *Nitrogen Fixation in Tropical Cropping Systems*. CAB international Wallingford, UK.
- Giovannetti M. and Mosse B. 1980. An evaluation of techniques for measuring vesicular-arbuscular mycorrhizal infection in roots. *New Phytol.* 84: 489–500.
- Häuser S. and Nolte C. 2002. Biomass production and N fixation of five *mucuna* varieties and their effect on maize yields in the forest zone of Cameroon. *J. Plant Nutr. Soil. Sci.* 165: 101–09.
- Hauser S., Henrot J. and Hauser A. 2002. Maize yields in mulched and burned *Mucuna pruriens* var. *utilis* and *Pueraria phaseoloides* relay fallow systems in Southern Cameroon. *Biological Agriculture and Horticulture* 20: 243–256.

- Holland M.D., Allen R.K.D., Campbell K., Gimble R.J. and Stricklings J.C. 1992. Natural and Human resources studies and land use options: Department of Nyong and So'o Cameroon. Natural Resource Institute, Chatham, UK.
- Houngnandan P., Sanginga N., Okogun A., Vanlanwe B., Merckx R. and Van Cleemput O. 2001. Assessment of soil factors limiting growth and establishment of *Mucuna* in farmers' fields in the derived savannah of the Benin republic. *Biol. Fertil. Soils* 33: 416–422.
- Houngnandan P., Sanginga N., Woomer P., Vanlanwe B., Merckx R. and Van Cleemput O. 2000. Response of *Mucuna pruriens* to symbiotic nitrogen fixation by rhizobia following inoculation in farmers' fields in the derived savanna of Benin. *Biol. Fertil. Soils* 30: 558–565.
- Mehlich M. 1984. Mehlich 3 soil test extractant: a modification of the Mehlich 2 extractant. *Commun. Soil Sci. Plant Anal.* 15: 1409–1416.
- Merryweather J.M. and Fitter A.H. 1991. A modified method for elucidation the structure of the fungal partner in a vesicular mycorrhiza. *Mycological Research* 95: 1435–1437.
- Motomizu S., Wakimoto P. and Toei K. 1983. Spectrophotometric determination of phosphate in river waters with molybdate and malachite green. *Analyst* 108: 361–367.
- Ngonkeu M.E.L. (2003). Biodiversité et potentiel des mycorrhiziens à arbuscules de quelques zones agro-écologiques du Cameroun. Thèse de Doctorat 3^e Cycle, Université de Yaoundé I. 258 p.
- Novozamsky I., Houba V.J.G., van Eck R. and van Vark W. 1983. A novel digestion technique for multiple-element plant analyses. *Communication in Soil Science and Plant Analyses* 14 : 239–248.
- Nwaga D. 1997. Production pilote de biofertilisants rhizobien et mycorrhizien au Cameroun: intérêt et contraintes *Cam. J. Biol. Biochem. Sci.* 7(1): 16–23.
- Nwaga D. and Ngo Nkot L. 1998. Tolérance à l'acidité *in vitro* de rhizobia isolées de *Vigna unguiculata* au Cameroun en comparaison avec *Bradyrhizobium japonicum*. *Cahiers Agricultures* 7: 407–410.
- Nwaga D., Ambassa-Kiki R. and Nsangou M.L. 1998. Agriculture biologique et amélioration de la productivité du niébé (*Vigna unguiculata*, Légumineuse) par les biofertilisants microbiens. *Biosciences Proceedings* 4: 293–301.
- Nwaga D., Ngonkeu M.E.L., Oyong M.M., Ngakou A., Abelong M.-P. and Foko J. 2000. Soil beneficial microorganisms and sustainable agricultural production in Cameroon: current research and perspectives. The biology and fertility of tropical soils, TSBF Report 1998, UNESCO-TSBF, Nairobi, Kenya, pp. 62–65.
- Nwaga D., The C., Ambassa-Kiki R., Ngonkeu Mangapché E.L. and Tchiegang-Megueni C. 2004. Selection of arbuscular mycorrhizal fungi for inoculating maize and sorghum, grown in oxisol/ultisol and vertisol in Cameroon. In *Managing nutrient cycles to sustain soil fertility in sub-Saharan Africa*. Ed. Batono A. ASP/TSBF Institute of CIAT; Nairobi, Kenya, pp. 467–486.
- Phillips J.M. and Hayman D.S. 1970. Improved procedure for clearing roots and staining parasitic and Vesicular-arbuscular mycorrhizal fungi for rapid assessment of infection. *Transactions of the British Mycological Society* 5: 158–161.
- Powers R.F., Van Gent D. and Townsend R.F. 1981. Ammonia electrode analysis of nitrogen in micro-Kjeldahl digests of forest vegetation. *Communication in Soil Science and Plant Analysis* 12: 19–30.
- Sanchez P.A. and Salinas J.G. 1981. Low-input technology for managing Oxisols and Ultisols in tropical America. *Adv. Agrom.* 34: 279–406.
- Sanginga N., Ibewiro B., Houngnandan P., Vanlauwe B., Okogun J.A., Akobundu I. O. and Versteeg M. 1996. Evaluation of symbiotic properties and nitrogen contribution of mucuna to maize grown in the derived savanna of West Africa. *Plant and Soil* 179: 119–129.
- Smith S.E. and Read D.J. 1997. *Mycorrhizal symbiosis*. Academic Press, San Diego, USA.
- Statistic Analysis Systems, Institute 1999. *SAS User's Guide: SAS Institute SAS/STAT User's guide, version 8.0*.
- Vincent J.M. 1970. *A manual for the practical study of root-nodule bacteria*. IBP handbook no. 15. Blackwell, Oxford.
- Vine H. 1953. Experiments on the maintenance of soil fertility at Ibadan, Nigeria, 1922–33. *Empire Journal of Experimental Agriculture* 21: 65–85.

Evaluating the effect of *Bacillus* and *Rhizobium*. bi-inoculant on nodulation and nematode control in *Phaseolus vulgaris* L.

Karanja N.K.* , Mutua G.K.* and Kimenju J.W.*

*Faculty of Agriculture, University of Nairobi, P.O. Box 30197 .Nairobi, Kenya.

Abstract

The study was undertaken to evaluate the effect of inoculating beans (*Phaseolus vulgaris* L.) with a bio-inoculant containing *Bacillus* spp. and *Rhizobium* spp. isolates on root damage by root-knot nematodes, nodulation and their interactions. Twenty *Bacillus* isolates from a previous experiment were selected based on their ability to reduce root-knot nematode populations and damage on beans. These isolates were screened to determine their compatibility with *Rhizobium* strains CIAT 899 and USDA 2674 *in vitro*. Seven *Bacillus* isolates were found to be compatible with the rhizobia strains. A greenhouse experiment to assess the effect of the dual inoculation of *Bacillus* and *Rhizobium* spp. on root damage by root-knot nematodes using sterile Leonard jar assembly revealed significant differences between the various treatment combinations. Damage by root-knot nematodes was generally lower in plants that were inoculated with both *Bacillus* and *Rhizobium* inoculation as compared to those that received rhizobia alone. Nodulation was significantly ($P \leq 0.05$) enhanced on bean plants even those that were treated with *Bacillus* alone. The seven isolates were then screened in a soil experiment in a glasshouse. Two *Bacillus* isolates caused an increase in nodulation, while the rest suppressed nodulation. Two isolates (K194 and K89) were found to have health promoting effects while the rest had growth promoting effects

Key words: *Bacillus* isolates, galling index, nodulation, *Rhizobium* strains CIAT 899 and USDA 2674, root-knot nematodes

Introduction

Common bean (*Phaseolus vulgaris* L.) is the most widely grown legume and only second to maize in importance as a food crop in Kenya (Wortmann and Allen, 1994). The crop is cultivated on an estimated 700,000 ha mainly in Eastern, Rift Valley, Western, Central and Nyanza provinces (Anon, 1996). Beans are primarily grown in the smallholder sector and are intercropped with other crops especially maize (Anon, 1990). Low yields of about 750 kg ha⁻¹ are realized, against a potential of 1500–2000 kg ha⁻¹ in Kenya (Rheenen et al., 1981). The main constraints to bean production include diseases, low soil fertility and insect pests (Otsyula et al., 1998).

Root-knot (*Meloidogyne* spp.) nematodes are recognized as a major constraint to bean farming, causing up to 60% yield losses in heavily infested fields (Ngundo and Taylor, 1974). Infection by root-knot nematodes is also known to suppress nodulation and hence nitrogen fixation in leguminous plants (Karanja, 1988; France and Abawi, 1994; Siddiqui and Mahmood, 1994; Kimenju et al., 1999). Several strategies have been developed for root-knot nematode management, but their application in subsistence agriculture is limited. Nematicides are too expensive while cultural practices such as fallowing and crop rotation are limited due to the polyphagous nature of *Meloidogyne* spp. and scarcity of arable land (Bridge, 1996). Widespread use of organic amendments is restricted because large

quantities are required for effective nematode control while use of resistant cultivars is usually unavailable (Rodriguez-Kabana, 1986; Sharma et al., 1994b).

Biological control has proved to be a viable option in the control of root-knot nematodes (Becker et al., 1988; Sikora, 1992). A number of biocontrol agents have shown high potential in reducing damage by nematodes in different crops (Bowmann et al., 1993; Oka et al., 1993). However, information on the effect of bio-control agents such as *Bacillus* spp. on root-knot nematodes and nodulation in beans is scanty. The aim of this experiment was to determine the effect of mixed inocula containing *Rhizobium* spp. and *Bacillus* spp. on nodulation and protection of bean roots against damage from root-knot nematodes in naturally infested soil conditions.

Materials and methods

This study was conducted at Kabete field station, Faculty of Agriculture at the University of Nairobi. The station is about 1940 m above sea level and lies within latitudes 1°14'20" to 1°15'15" S and longitudes 36°4' to 36°45'20" E. The soils are predominantly deep red eutric nitosols containing 60–80% clay particles. The clay mineral is predominantly kaolin while the parent material is the Kabete trachyte. The pH ranges between 5.2–7.2 (Nyadat and Michieka, 1970). The screening of bacteria isolates were carried out under controlled laboratory conditions while a few strains that showed compatibility were further tested in the greenhouse. This paper presents data obtained from the pot-greenhouse experiment only.

Evaluation of a bio-inoculant containing Bacillus sp. and Rhizobia on nodulation and nematode damage on beans

In an earlier study Macharia (2002), evaluated the effect of *Bacillus* isolates on root-knot nematodes using sterile and non-sterile media under glasshouse conditions. A total of 250 *Bacillus* isolates were screened in three batches to evaluate their activity against nematodes and sixteen of them (K48, K51, K61, K66, K67, K158, K194, K100, CB4, K269 K61, K66, K67, K194, K236 and K270) were effective, against plant parasitic nematodes. These isolates were subjected to evaluation for their compatibility with two rhizobia strains, that

are commercially used for production of bean inoculant at the Microbial Resource Centre, Department of Soil Science and they were *Rhizobium tropici* (CIAT 899) and *Rhizobium leguminosarum biovar phaseoli* (USDA 2674). Serial dilutions of cultures containing *Bacillus* isolates, *Bacillus* + Rhizobia and *Rhizobium* were made and 0.1 ml of 10³ to 10⁶ dilutions were plated on Yeast extract mannitol agar (YEMA) extract mixed with Congo red dye that eases identification of the rhizobia colonies which pick the red dye (Becker et al., 1988). These were then incubated at 27°C for 48 hours after which colonies formed were identified using cultural and morphological characteristics as outlined by Claus and Berkeley (1986). Six *Bacillus* isolates viz. K158, CB4, K194, K67, K89, and K86 were found to successfully grow in the presence of rhizobia with no inhibition.

These *Bacillus* isolates that grew together with rhizobia were then inoculated into YEMA broth and incubated in an orbital shaker for 3–5 days at 22–25°C when the culture contained a population of about 10⁹ cfu ml⁻¹. Thoroughly cleaned building sand was placed in Leonard jars (Leonard, 1943) and steam sterilized for 1 hr at 125°C. Three bean seeds were then sown in each jar but thinned to one seedling at emergence after which the seedlings were inoculated with 2 ml containing 1000 eggs/juveniles. 1 ml was pipetted into each of the two indentations made at the base of the plant. Treatment combination included, CIAT 899 + selected *Bacillus* isolates, USDA 2674 + selected *Bacillus* isolates, CIAT 899 alone and USDA 2674 alone. Control treatments included plants inoculated with *Bacillus* isolates containing 10⁹ cfu ml⁻¹ and 1 ml of individual *Rhizobium* strains (10⁹ cfu ml⁻¹) were fertilized with a nitrogen-free nutrient solution (Somasegaran and Hoben, 1994). The treatments were arranged in a completely randomized design with five replications. The experiment was terminated 45 days after inoculation where second stage juveniles (J2) were extracted from 200 cm³ sand obtained from each of the jars by the modified Baermann funnel technique using extraction dishes (Hooper, 1990). The sand was spread on a double layer of milk filters supported by a sieve. The sieves were then placed in a shallow dish and water added to a level where it just touched the sand so that the soil layer looked wet. After 24 hours, the sieves were carefully removed and the nematode suspension concentrated by passing through a series of 45 µm – aperture sieves and the juveniles collected from each of the sieves. One-ml aliquots of a well-agitated nematode suspension was then pipetted into a counting slide

and observed under a light microscope. Counting was repeated for four aliquots and the average calculated. Data on gall numbers, number of nodules and dry shoot weights were also recorded.

Effect of bio-inoculant on bean nodulation and nematode infection using field infested soils under glasshouse conditions

The above experiment was repeated in the greenhouse using naturally nematode-infested soil to simulate field conditions. Surface soil (0–20 cm depth) was obtained from a known nematode infested plot and thoroughly mixed to make it homogenous. The soil, which was minimally disturbed, was then placed in 2kg pots and the number of nematodes per pot quantified (Pi) using the technique described by Hooper (1990). Treatments were as described in experiment (a) above. Diammonium phosphate was applied at the rate of 5 g per pot at planting and the treatments arranged in a completely randomized design with eight replications. The experiment was terminated 45 days after inoculation. Data on gall numbers, juvenile counts, number of nodules and dry shoot weights were recorded from the seedlings as in (a) above.

Results

Effect of combining Bacillus spp. and Rhizobium bean inoculant on root-knot nematodes under sterile conditions

Bacillus alone or in combination with *Rhizobium* strain USDA 2674 suppressed Gallings indices were significantly ($P = 0.05$) lower among plants treated with *Bacillus* spp. combined with different *Rhizobium* strains (Table 1 and 2). Gallings was lowest in plants treated with *Bacillus* isolate K194 + USDA 2674 and K194 + CIAT 899 and those treated with isolate K67 + USDA 2674. The highest gallings was observed in non-inoculated plants (control). There were significant ($P = 0.05$) differences in juvenile (J2) populations among treatments with various *Bacillus* and *Rhizobium* combinations (Tables 1 and 2). The lowest number of J2 was recovered from soil treated with *Bacillus* isolate K194 combined with each of the two (USDA 2674 and CIAT 899) *Rhizobium* isolates. The juvenile population was highest in soil treated with *Rhizobium* strain USDA 2674 alone (Table 1). K194 + USDA 2674 and K67 + CIAT 899 showed the highest dry shoot weight while the least was recorded in the controls. Gallings and egg masses were significantly ($p \leq 0.05$) lower in

Table 1. Gallings index, egg mass index, numbers of *Meloidogyne* juveniles (J2) and dry shoot weight of bean plants treated with *Bacillus* spp. and USDA 2674

<i>Bacillus</i> Isolate	Gallings index		Egg mass index		J2/ 200cm ³ soil		Nodule numbers		Dry shoot wt (g)	
	Test		Test		Test		Test		Test	
	1	2	1	2	1	2	1	2	1	2
Control	7.0	6.9	7.2	7.1	194	190	0	0	0.4	0.6
CB4	5.0	4.9	4.7	4.6	50	60	0	0	1.9	1.8
CB4 +USDA 2674	4.5	4.4	4.7	4.5	27	32	96	100	2.5	2.4
K158	3.5	3.2	3.5	3.6	32	34	0	0	1.3	1.2
K158+USDA 2674	2.7	2.3	3.0	2.9	25	26	216	201	3.4	3.2
K194	1.0	1.1	1.0	1.0	17	20	0	0	4.7	4.7
K194+USDA 2674	1.0	1.0	1.0	1.0	22	21	334	321	4.7	4.9
K67	2.5	2.6	3.0	3.1	33	30	0	0	2.0	2.2
K67+USDA 2674	1.8	1.9	1.5	1.6	36	30	194	181	2.6	2.8
K86	3.0	2.9	2.3	2.4	51	60	0	0	3.7	3.8
K86+USDA 2674	2.0	2.1	2.0	2.0	43	51	201	189	4.2	4.0
K89	4.5	4.4	4.2	4.2	54	56	0	0	2.9	1.9
K89+USDA 2674	4.7	4.5	4.5	4.4	56	61	164	154	2.5	2.3
USDA alone	6.3	6.0	5.5	5.5	345	321	250	236	3.2	3.2
CV(%)	3.6	3.7	2.6	2.5	51.0	48.0	0.7	0.6	1.0	1.0
LSD ($P \leq 0.05$)	0.7	0.6	0.6	0.5	153.4	148	7.7	7.5	0.4	0.3

Table 2. Gallings index, egg mass index, numbers of *Meloidogyne* juveniles (J2) and dry shoot weight of bean plants treated with *Bacillus* spp and *Rhizobium* strain CIAT 899

<i>Bacillus</i> Isolate	Galling index		Egg mass index		J2/ 200cm ³ soil		Nodules numbers		Dry shoot wt (g)	
	Test		Test		Test		Test		Test	
	1	2	1	2	1	2	1	2	1	2
Control	7.5	7.4	6.0	6.0	191	196	0	0	0.5	0.4
CB4	2.7	2.6	2.3	2.4	40	42	0	0	1.6	1.5
CB4 +CIAT 899	5.5	5.6	6.0	6.1	50	56	105	111	2.9	2.9
CIAT 899	6.5	6.5	5.7	6.0	132	140	243	240	3.0	3.2
K158	2.3	2.2	2.0	2.0	55	60	0	0	1.7	1.6
K158+CIAT 899	2.5	2.5	2.8	2.7	23	24	207	210	3.2	3.3
K194	1.2	1.1	1.2	1.1	16	18	0	0	2.5	2.4
K194+CIAT 899	2.0	1.8	1.0	1.0	17	16	328	330	3.7	3.8
K67	2.8	2.7	2.2	2.0	40	42	0	0	1.7	1.6
K67+CIAT 899	3.5	3.4	2.5	2.2	48	48	185	190	4.1	3.8
K86	2.8	2.9	2.2	2.3	30	36	0	0	2.9	2.6
K86+CIAT 899	2.0	2.3	3.7	3.6	31	40	206	210	2.4	2.6
K89	3.2	3.4	3.0	3.1	41	43	0	0	2.5	2.3
K89+CIAT 899	3.8	3.9	2.7	2.6	50	56	246	250	2.9	3.0
CV(%)	6.4	6.5	3.1	3.0	4.3	4.5	0.4	0.3	1.2	1.5
LSD ($P \leq 0.05$)	1.0	1.0	0.7	0.7	8.8	8.9	4.3	4.5	0.1	0.1

Table 3. Effect of *Bacillus subtilis* and bio-inoculant (CIAT 899) on nodulation and nematode infection using field infested soils in a pot experiment under glasshouse

<i>Bacillus</i> Isolate	Galling index		Egg mass index		J2/ 200cm ³ soil		Nodules numbers		Dry shoot wt (g)	
	Test		Test		Test		Test		Test	
	1	2	1	2	1	2	1	2	1	2
Control	7.2	7.8	7.5	7.8	584	599	63	64	1.4	1.2
CB4	5.1	5.2	5.1	5.0	459	481	83	85	2.1	2.1
CB4 +CIAT 899	4.6	4.4	4.8	4.9	465	464	102	100	2.7	2.6
CIAT 899	4.8	4.6	5.2	5.2	510	513	231	228	3.4	3.2
K158	3.8	3.9	3.6	3.8	136	140	93	96	2.2	2.0
K158+CIAT 899	2.4	2.6	2.8	2.6	127	120	210	200	3.5	3.3
K194	1.1	1.1	1.0	1.1	93	82	93	98	4.4	4.0
K194+CIAT 899	1.0	1.0	1.0	1.0	95	86	328	330	4.7	4.3
K67	3.8	3.9	3.1	3.0	190	185	74	60	2.2	2.0
K67+CIAT 899	2.3	2.5	2.3	2.2	194	190	191	198	2.9	2.7
K86	2.5	2.6	2.6	2.5	410	400	97	93	3.5	3.2
K86+CIAT 899	3.4	3.6	4.1	4.0	410	393	196	201	4.1	3.9
K89	4.8	4.6	4.6	4.5	135	132	104	100	3.1	3.2
K89+CIAT 899	4.0	.9	3.9	3.9	129	132	260	254	2.6	2.4
CV (%)	4.0	4.1	3.5	3.2	6.2	6.0	3.7	4.1	3.2	4.8
LSD ($P \leq 0.05$)	0.6	0.5	0.5	0.4	17.2	16.9	14.6	15.0	0.3	0.2

plants treated with *Bacillus* isolates alone or in combination with *Rhizobium* Strain CIAT 899 (Table 3) compared to the control. The lowest damage by nematodes and eggmasses were recorded in plants treated with *Bacillus* isolate K194 and when combined with

Rhizobium strain CIAT 899. Compared to the control, juvenile numbers were lower in soil treated with *Bacillus* spp alone or in combination with *Rhizobium* strain CIAT 899. Nodule numbers were higher in soil treated with isolates of *Bacillus* with the exception of isolate

K67. Without exception, shoot weight was higher in plants treated with *Bacillus* alone or in combination with *Rhizobium* strains CIAT 899, compared to the control.

Results presented in table 4 show that application of isolates of galling, eggmass index and juvenile numbers in the soils in a trend similar to that observed in table 3. Nodule numbers were highest in plants grown in soil infested with *Bacillus* isolate K194 and *Rhizobium* strain USDA 2674. All the isolates of *Bacillus subtilis* and their combinations with *Rhizobium* strain USDA 2674 caused an increase in shoot dry weight.

Discussion

This study demonstrated that some strains of *Bacillus subtilis* isolated from Kenyan soil could be used to control root-knot nematodes affecting beans. Sikora (1988, 1990) reported that approximately 9% of rhizobacteria isolated from soils had plant health promotion activity and were antagonistic to plant parasitic nematodes. The seven bacillus isolates tested were found to significantly reduce the galling index, juvenile population and even the reproductive potential of the nematodes. The mode of action exhibited by *Bacillus* spp. is diverse and includes production of toxic substances, reduction of the activity of egg hatching factors, alteration of root exudates and inhibition of nematode penetration

into the roots thereby reducing root galling. Bacteria found in the rhizosphere have been reported to improve plant growth and/or root health (Kloepper et al., 1980; Schroth and Hancock, 1982; Schipper, 1988; Sikora, 1988; Weller, 1988; Kloepper et al., 1989). Rhizobacteria are divided into two groups according to their mode of action; plant growth promoting rhizobacteria (PGPR) and plant health promoting rhizobacteria (PHPR) (Sikora, 1988, 1990). PGPR represent all beneficial rhizobacteria while PHPR are those that stimulate plant growth by suppressing plant pathogens or parasites (Ordentlich et al., 1987; Kloepper and Schroth, 1981). Several studies have shown that legume nodulation is influenced by soil microorganisms which occur naturally in the rhizosphere (Schroth and Becker, 1990). *Bacillus* Spp. has been found to enhance nodule formation (Halverson and Handelsman, 1991). This study revealed that some strains of *Bacillus subtilis* enhanced nodulation in bean plants. In contrast nodulation was suppressed in some bean plants inoculated with *Bacillus* spp. as demonstrated by Srinivasan et al. (1997). Inoculation of *P. vulgaris* with *Bacillus megaterium* and *Bradyrhizobium* strain TAL 644 neither induced root hair proliferation nor enhanced nodulation (Srinivasan et al., 1996). Increased plant growth was observed in plants in which nodulation was enhanced as was observed by Srinivasan et al. (1997), Araujo et al. (1999), and El-Sayed (1999). Increased nutrient uptake

Table 4. Effect of bio-inoculant (USDA 2670) on bean nodulation and nematode infection using field infested soils in a pot experiment under glasshouse

<i>Bacillus</i> Isolate	Galling index		Eggmass index		J2/200cm ³ soil		Nodules numbers		Dry shoot weight(g)	
	Test		Test		Test		Test		Test	
	1	2	1	2	1	2	1	2	1	2
Control	7.1	7.6	7.4	7.8	577	589	90	92	0.3	0.2
CB4	5.1	5.0	5.1	5.2	439	441	83	86	2.1	1.9
CB4 +USDA 2674	4.6	4.5	4.8	4.9	440	439	115	110	2.7	2.5
K158	3.8	3.7	3.6	3.8	131	139	113	110	2.2	2.0
K158+USDA2674	2.4	2.3	2.8	2.9	129	130	218	199	3.5	3.4
K194	1.1	1.2	1.0	1.0	95	89	93	90	4.8	4.3
K194+USDA2674	1.0	1.0	1.0	1.0	93	83	333	313	4.7	4.2
K67	3.8	3.6	3.1	3.2	190	201	120	119	2.3	2.1
K67+USDA 2674	2.3	2.3	2.3	2.4	186	192	251	240	2.8	2.6
K86	2.5	2.2	2.6	2.7	408	396	78	72	2.5	2.4
K86+USDA 2674	3.4	3.3	4.1	4.3	411	389	188	182	3.8	3.6
K89	4.8	4.7	4.6	4.7	131	129	110	119	3.1	3.0
K89+USDA 2674	4.0	4.0	3.9	3.9	128	120	226	220	2.6	2.4
USDA 2674	4.8	4.9	5.2	5.5	515	499	224	220	3.2	3.0
CV (%)	4.4	5.0	3.7	4.2	2.2	4.2	2.9	3.6	2.5	4.6
LSD ($P \leq 0.05$)	0.6	0.4	0.6	0.6	21.6	22.3	17.7	16.9	0.3	0.2

due to increased root hair formation, influence of phytohormones especially auxin and nitrogen fixation due to increased nodulation could account for the increase in plant growth (Bauer, 1981; Turner and Backman, 1991; Srinivasan et al., 1996).

This showed that inoculation with *Bacillus* Spp. enhanced their vigour, which could have led to increased tolerance to nematode damage. Nematode population, eggmass and galling indices were found to be relatively higher in the non-sterile experiment mainly due to the buffering effect of soil that tends to reduce the effect of the *Bacillus* isolates on the nematodes.

Conclusion

Increased nodulation was observed in bean plants inoculated with some *Bacillus* isolates, and this led to improved plant growth. Application of *Bacillus* spp. in root-knot nematode management would therefore have an added advantage of enhancing nitrogen supply to the plant.

Acknowledgement

The authors are grateful for financial support from TSBF-CIAT-AFNET Programme. The Department of Crop Protection, University of Nairobi is acknowledged for technical assistance.

References

Anonymous 1996. Provincial annual reports for Central, Eastern, Rift valley and Western provinces. Ministry of Agriculture, Republic of Kenya. Nairobi, Kenya.

Araujo, F.F., de Hungaria M. and de-Araujo F.F. 1999. Nodulation and yield of soybeans co-inoculated with *Bacillus subtilis* and *Bradyrhizobium japonicum*/ *Bradyrhizobium elkanii*. Pesquisa Agropecuária Brasileira 34: 1633–1643.

Bauer, W.D. 1981. Infection of legume by rhizobia. Annual Review of Plant Physiology 32: 407–449.

Becker, J.O., Zavaleta-Mejia, E., Colbert, S.F. et al. 1988. Effects of rhizobacteria on root-knot nematodes and gall formation. Phytopathology 78:1466–1469.

Bridge, J. 1996. Nematode management in sustainable and subsistence agriculture. Annual Review of Phytopathology 34: 201–225

Bowmann, J.P., Sly, L.L., Hayward, A.C., Spiegel, Y. and Stckenbrandt, E. 1993. *Telluria mixta* and *Telluria chiolytica* sp. Nov. soil dwelling organism which actively degrade polysaccharide. International Journal of Systemic Bacteriology 43:120–124.

Claus, D. and R.C.W. Berkeley. 1986. Genus *Bacillus* Cohn 1872, pp. 1105–1139. In: P.H.A. Sneath et al. (eds.), Bergey's Manual of Systematic Bacteriology, Vol. 2. Williams and Wilkins Co., Baltimore, MD.

El-Sayed, S.A.M. 1999. Denitrification by guar Rhizobia strains in New Valley Governorate. Egypt Journal of Soil Science 39:223–236

Halverson L.J. and Handelsman J. 1991. Enhancement of soy-bean nodulation by *Bacillus cereus* UW85 in the field and in a growth chamber. Appl. Environ. Microbiol. 57: 2767–2770.

Hooper D.J. 1990. Extraction and processing of plant and soil nematodes. In: Luc M. Sikora R.A. and Bridge J (Eds) Plant Parasitic Nematodes in Subtropical and Tropical Agriculture. pp. 45–68, CAB International, Wallingford.

Kimenju J.W., Karanja N.K. and Macharia I. 1999. Plant parasitic nematodes associated with common bean in Kenya and the effect of *Meloidogyne* infection on bean nodulation. African Crop Science Journal 7: 503–510.

Klopper J.W., Schroth M.N. and Miller T.D. 1980. Effect of rhizobacteria colonization by plant growth promoting rhizobacteria on potato plant development and yield. Phytopathology 70: 1078–1082.

Klopper, J.W. Lifshitz, R. and Zablutowicz. R.M. 1989. Free-living bacterial inocula for enhancing crop productivity. Trends in Biotechnology., 7, 39–43.

Klopper, J.W. and Schroth, M.N. 1981. Development of a powder formulation of rhizobacteria for inoculation of potato seed pieces. Phytopathology 71: 590–592.

Leonard, L.T. 1943. A simple assembly for use in the testing of cultures of rhizobia. Journal of Bacteriology 32: 511–519.

Ngundo, B.W. and Taylor, D.P. 1974. Effect of *Meloidogyne* spp. on bean yields in Kenya. Plant Disease Reporter 58: 1020–1023.

Nyadat N.N. and Michieka D.O. 1970. Soils of Kirima Kimwe, Faculty of Agric, farm. National Agricultural Laboratories, M.A. Kenya

Oka, Y., Chet, I., and Spiegel, Y. 1993. Control of root-knot nematode *Meloidogyne javanica* by *Bacillus cereus*. Biocontrol Science and Technology 3: 115–126.

Oostendorp M, Sikora RA. 1990. *In-vitro* interrelations between rhizosphere bacteria and *Heterodera schachtii* Revue Nematologie 13: 269–74

Ordentlich A., Elad Y. and Chet I. 1987. Rhizosphere colonization by *Serratia marcescens* for the control of *Sclerotium rolfsii*. Soil Biology 19: 747–751.

Otsyula, R.M., Ajanga, S.I., Buruchara, R.A. and Wortmann, C.S. 1998. Development of an integrated bean root rot control strategy for western kenya. African crop science journal, vol. 6. no. 1, pp. 61–67,

Rodriquez-Kabana, R. 1986. organic and inorganic nitrogen amendments to soil as nematode suppressants. Journal of Nematology 18(2):129–135.

Schipper B. 1988. Biological control of pathogens with rhizobacteria. Philosophical Transactions of the Royal Society of London B 318: 283–293.

Schroth, M.N. and Hancock J.G. 1982. Disease suppressive soil and root-colonizing bacteria. Science 216: 1376–1381.

Schroth, M.N. and Becker, J. 0.1990. Concepts of ecological and physiological activities of rhizobacteria related to biological control and plant growth promotion. pp. 389–414 in: Biological control of soil-borne plant pathogens. Hornby, D. ed. Wallingford, CAB International.

- Sharma, H.C., B.V.S. Reddy, J.W. Stenhouse and K.F. Nwanze, 1994b. Host plant resistance to sorghum midge. *International Sorghum Millets Newsl* 35: 30–41.
- Sikora, R.A. 1988. Interrelationships between plant health promoting rhizobacteria, plant parasitic nematode and soil microorganism. *Md. Fac. Landbouww Rijksuniv. Gent* 1988 52/26 867–878.
- Sikora, R.A. 1992. Management of the antagonistic potential in agricultural ecosystems for the biological control of plant parasitic nematodes. *Annual Review of Phytopathology* 30:245–270.
- Somasegaran, P. and Hoben, H.J. 1994. *Handbook for Rhizobia: Methods in Legume-Rhizobium Technology*. Springer-Verlag, New York. 450 pp.
- Srinivasan, M, Petersen, DJ, Holl, FB (1997) Nodulation of *Phaseolus vulgaris* by *Rhizobium etli* is enhanced by the presence of *Bacillus*. *Canadian Journal of Microbiology* 43(1): 1–8.
- Srinivasan, M., D.J. Peterson, and F.B. Holl. 1996. Influence of IAA producing *Bacillus* isolates on the nodulation of *Phaseolus vulgaris* by *Rhizobium etli*. *Canadian Journal of Microbiology* 42: 1006–1014.
- Turner J.T. and Backman P.A. 1991. Factors relating to peanut yield increase following *Bacillus subtilis* seed treatment. *Plant Dis.* 75: 347–353.
- Van Rheenen, H.A., Hasselback, D.E. and Muigai, S.G.S. 1981. The effect of growing beans together with maize on incidence of bean diseases and pests. *Netherlands Journal of Plant Pathology* 78:527–535.
- Weller D.M. 1988. Biological control of soil borne pathogens in the rhizosphere with bacteria. *Ann. Rev. of Phytopathol* 26: 379–407.
- Wortmann, C.W. and Allen, D.J. 1994. African bean production environments: their definitions, characteristics and constraints. *Network on Bean Research in Africa, Occasional Paper Series No. 11*, Dar es Salaam, Tanzania.
- Wortmann C.S., Kirby R.A., Elebu C.A. and Allen D.J. 1998. Atlas of common bean (*Phaseolus vulgaris*) production in Africa. *Cali Colombia CIAT* 33p.

Integrated Soil Fertility Management Technologies: review for scaling up

Michael Misiko¹ and Joshua Ramisch²

¹*Anthropologist, and a student at the Technology and Agrarian Development Chair-group of Wageningen University and Research Centre, The Netherlands;* ²*Human Ecologist, and the Social Science Officer of TSBF-CIAT, Nairobi, KENYA; Tropical Soil Biology and Fertility Institute (TSBF) of CIAT; P.O. Box 30677, UN Avenue, Nairobi, KENYA; m.misiko@cgiar.org and j.ramisch@cgiar.org*

Abstract

It is recognised that smallholder farmers in Sub-Saharan Africa significantly depend on land for their livelihoods. Nevertheless, these livelihoods are constrained by inherent low soil fertility. Over a long time, researchers and farmers have battled to arrest soil fertility degradation. Over the last decade, this battle has resulted in the development of integrated soil fertility management (ISFM) technologies. Between 2001 and 2004, Tropical Soil Biology and Fertility (TSBF) researchers and local small-holder farmers in western Kenya have been adapting these technologies to local circumstances under the community-based initiative called Strengthening Folk Ecology (FE). This initiative involved participatory demonstration-trials and dialogue as principal methods in the learning and adaptation process. Follow up studies have been undertaken to identify successful cases of this process. Initial results show that although such cases are few and far between, they are promising and benefits need to be scaled up for wider use by farmers in areas beyond the FE sites. Nevertheless, scaling ISFM technologies is complicated. ISFM technologies are knowledge intensive and their adaptations and applications are diverse. This paper provides insights into this problem by discussing selected ISFM technologies with regard to their inherent scalability

Key words: scaling up, ISFM technologies, partnerships

Introduction

Integrated Soil Fertility Management (ISFM) refers to making the best use of inherent soil nutrient stocks, locally available soil amendments (for instance, crop residues, compost, animal manure, green manure), and inorganic fertilisers to increase productivity while maintaining or enhancing the agricultural resource base (IFDC, 2003; TSBF, 2003). Since 1984, the Tropical Soil Biology and Fertility Institute (TSBF) has partnered with farmers and other agricultural institutions in research, dialogue, learning and adapting ISFM technologies to fragile ecological conditions (Misiko, 2001). Between 2001 and 2004, TSBF engaged farmers in a community-based learning initiative called “Strengthening Folk Ecology” (FE). Under this initiative, ISFM technologies under four established

concepts were disseminated to farmers. These concepts were, resource quality i.e., biomass transfer, organic-inorganic fertiliser combinations, cereal-legume rotation and fertiliser application rates.

Strengthening Folk Ecology

The FE is a community-based interactive learning initiative. Its focus is to broaden farmer’s soil fertility management strategies by incorporating scientific insights of soil biology and fertility into their repertoire of folk knowledge and practical skills. The major objective of this project is to develop innovative and interactive learning tools that facilitate the exchange of knowledge and skills between farmers, scientists and other agricultural knowledge brokers.

In 2001, TSBF researchers conducted a series of in-depth studies in four sites of Aludeka, Bukhalalire, Emuhaya and Muyafwa, all in western Kenya. Results from these studies showed that farmers preferred hands-on learning methods to improve their understanding and use of ISFM technologies. As a result, farmers settled on demonstration-trials as a means to enhance learning and promote dialogue. Dialogue and demonstration-trials were therefore, the two key methods used in the FE initiative and were managed under a partnership of local institutions and researchers.

Methods and the partnership

The FE was mainly a partnership of TSBF researchers, the Ministry of Agriculture (MoA) and local farmers and organisations: farmer field schools (FFS), in Emuhaya; and farmers' research groups (RGs) in Aludeka, Bukhalalire and Muyafwa. Members of these RGs elected representatives who kept collective records. Their other role was to inform RG's members about meetings and to encourage other farmers in their villages to participate in demonstrations' and other research events systematically.

During planning and initiation stage, community interviews, open and informal dialogue, focus group discussions (*FGD*), informal interviews were held to elicit information on local soil fertility knowledge and practices and perceptions of farmers. Open community-level meetings were held to explain TSBF in general and the objectives of FE in particular. During these meetings, all possible soil fertility management related questions were entertained, all expectations and objectives of farmers were noted. Discussions also dwelt on roles of both TSBF researchers and farmers in this initiative. A common understanding with farmers was reached on: data to be collected by all parties; responsibilities and roles in managing the demonstration-trials; alternative organic resources to be used as treatments; suitable locations of demonstrations, their arrangements and management. In each site, FFS and RGs came up with their own criteria of who amongst their members would host which demonstrations. Importantly, ISFM technologies had been explained to farmers and a systematic process of selecting technologies that were demonstrated was therefore possible. During the trials, farmers and researchers met after every fortnight to *do* and discuss the four concepts. As a learning process, farmers kept their own records and organised independent meetings more regularly to

manage and evaluate the trials and receive other local farmers and visitors.

ISFM concepts on the demonstration-trials

Mother demonstration-trials were designed with participating farmers to test and evaluate four ISFM concepts under local conditions. The four concepts were i) resource quality or biomass transfer ii) cereal-legume rotations iii) organic-inorganic fertiliser combinations and iv) fertiliser application rates – P and Farm Yard Manure (FYM).

Resource quality or biomass transfer

This concept involves selection of organic materials on the basis of their quality and direct incorporation of those materials into the soil as manures. Depending on their rate of decay and nitrogen (N) release, materials can be applied at planting or weeks before.

Scientists at TSBF had devised a guide for selecting the quality of organic resources for soil fertility improvement. This guide, known as Organic Resource Database (ORD), was simplified during the learning process of the FE initiative. The simplified version, for example, put emphasis on four criteria for determining quality of resources: green colour, taste, waxy surface and tearing. Farmers also preferred to use rate of decomposition as useful criterion. The above criteria were used to select *Tithonia*, *Calliandra* and *FYM* as representative local organic resource-manures. These materials were each used to grow maize on adjacent 6 m × 6 m plots. Those plots were evaluated continuously by farmers (FFS and RGs) till harvesting. Harvest results confirmed that *Tithonia*, *Calliandra* and *FYM* represented three respective quality-classes, i.e., high, medium and low.

Cereal-legume rotation trials

The concept of crop rotations has been in use in western Kenya for ages. Nonetheless, cereal-legume rotations were aimed at promoting rotation systems that would sustain soil fertility while providing immediate food and economic needs for the smallholder farmers. During the first season of 2002, legumes (mucuna, yellow and green grams, ground nuts and soybeans) were planted on 6 m × 6 m plots. Maize was planted

during the second season as a test crop to evaluate the benefits of incorporated legume-biomass and biological N_2 -fixation of the different species. In Muyafwa and Emuhaya, *Striga hermontheca* interfered with the test-plant maize. Nevertheless, farmers rated mucuna and soybean-plots as impressive.

Organic-inorganic fertiliser combination trials

Farmers were informed that inorganic fertilisers are vital. Participating farmers were able to appreciate this by observing soil nutrient test strips that had been planted parallel to the main trials. The soil nutrient test strips had shown that local soils were extremely mined. Therefore, the main message was that inorganic fertilisers would play a unique role, for instance supply *P* adequately than organic resource manures. These trials were used to explain the sources of *P* and *N*, and farmers conveniently labelled these nutrients for easy remembrance. The underlying value for this demonstration-trial was to provide a logical basis that could guide fertiliser selection. This trial was closely linked to the first concept; due to the scarcity and poor quality of local resources, farmers would appreciate the essence of, especially, supplementary *P*-fertilisers.

Fertiliser application rates trials

The underlying rationale in this concept was that both organic and inorganic fertilisers have an optimum level of performance. Farmers were able to observe that inorganic *P* had good residual effect, and that levels of application of organic manures depended on their quality. The theme of this concept therefore, widened to include *FYM* quality and its maintenance through appropriate preparation and storage.

Generated knowledge and practices

Resource quality or biomass transfer: one of the adapted aspect included use of local organic resources in quantities and on crops different from those that were used on demonstration plots. Researchers had encouraged this.

Two cases of farmers putting *Tithonia* in compost pits with slow decaying materials with the view to 'speed up' the rate of decomposition were recorded.

In the language of one of the farmers on whose farms this was observed, "*Tithonia* had been proven as good on scientific plots. . . ." During the first season, planting was followed by rain failure, and some crop seed were choked. Due to this, this farmer had observed that "*Tithonia* was a hot material" comparable to Diamonium phosphate (DAP). The two farmers who had adapted the principle of resource quality this way did not weigh maize harvests from the sections the "improved" compost was applied. Two key informants in Muyafwa and Bukhalalire had used *Tithonia* as a pesticide in the past.

In 2004, many participating farmers planned systematic baby trials and the process was followed up systematically by the researcher. Already, one farmer in Muyafwa had attempted to replicate two resource quality plots on his farm. He said he had no intention to sustain the process but to prove on his own that what was being carried out was sensible. His premise was that the type of soil on the mother trial was better than that on his farm. Later, the researcher visited this farmer. He showed the researcher a section of his vegetable garden where he had used *Tithonia* on "roasting maize".

Cereal-legume rotation trials: it is early to state with certainty the results of adaptation. There were intervening factors (Giller, 2001), particularly groundnut rosette, *Striga* infestation and poor rainfall during the second season. Data from *FGDs* showed that soybeans were being preferred due to new market prices. Other emerging results showed that farmers preferred soybean hoping that it would fix *N* while at the same time benefit other crops inter-cropped with it. This way, farmers were intending to replace *N*-fertilisers with biological *N*-fixation processes.

In the past, consistent planting of legumes such as groundnuts and green grams as commercial crops due to price incentives have shown that with time, farmers intentionally or inadvertently discover new aspects that were previously unknown. For instance, seed selection skills, pest resistance and time of planting. This knowledge formation is sustained by, for instance, the relative market advantage that these crops enjoyed. Farmers had been selecting planting seeds and sharing them with their relatives, neighbours, friends or selling them. To conclude, these crops had formed new possibilities that were originally unknown.

Organic-inorganic fertiliser combinations trials: follow up in-depth interviews, farm visits and observation that have been carried out so far point to well-documented reasons such as costs involved in purchasing *P* fertilisers. Interviewed farmers said they

would prefer to use inorganic fertilisers for commercial vegetable growing.

A study under the FE on home-gardens showed that commercial farming of vegetables, especially kale, is considered by local farmers as vital. Kale was the only crop that some farmers watered during the dry spells and which was actively marketed on local markets. For instance, four key informants in Muyafwa and Emuhaya used DAP and *Tithonia* only on kale, and actively sought tenders to supply local schools and hotels with the produce. These types of activities were done collectively among the well-networked groups of Emuhaya.

Fertiliser application rates trials: initial indications show that dialogue is still needed over quality maintenance. It was realised that use of quality resources must go hand in hand with quality management. Routines in preparation and management of *FYM* amongst farmers that were visited had not changed. In addition, farmers found the “optimum” levels derived from the *P* and *FYM* response trials to be too high and therefore costly. The FE is still translating some of these lessons into brochures for farmers.

During the first planting season of 2004, more demonstrations were planted in all FE sites according to site-specific farmers’ preferences. These preferences were considered to be initial indication about scalability of ISFM-Ts and their benefits. The process of evaluating these demonstrations with farmers is going on and also “babies” or satellite subsets comprising some of the original concepts from the “mothers” are coming up in the fields of participating farmers under individual management. In general, available results do provide general patterns.

Analysis

The process of disseminating and adapting ISFM concepts to local use is still going on. Such process is long-term, and should be viewed as knowledge generation resulting from disseminated concepts rather than a short measurable process.

Patterns in emerging practices

The emerging patterns in the above cases show three kinds of adaptations of the original ISFM concepts:

i) Those curiously done, for instance trying to see *whether* scientists were honest. A good example was the farmer in Muyafwa who had tried to replicate two resource quality plots on his farm. That incident revealed that the information scientists gave as ‘researched’ evidence would be contested. This farmer for instance, did not only test research knowledge; he generated new knowledge and brought into focus factors like soil type. Results may later be translated into a routine, flexible practice.

ii) Those performed to solve non-intended functions. The two farmers referred to above used *Tithonia* as an ingredient of a pesticide concoction. This knowledge was not however new. It had simply come to the forefront due to FE effort to integrate indigenous and scientific methods. A more appropriate example in this second category is intercropping legumes and cereal crops, and not rotating them. Due to land shortage especially in Emuhaya, farmers had hoped to fix N_2 biologically and at the same time improve harvest, but without use of other fertilisers. During the demonstration, farmers had been informed that although legumes could fix N , other crops would not benefit while the legumes were still growing. Two key informants in Emuhaya said they had expected that legumes, just like beans, would be inter-cropped. The challenge in this farmer’s line of debate was that initial results were not promising and the original concept would therefore not be passed to other farmers.

Many participating farmers were able to recognise that the most basic requirement for legumes to form an effective N_2 -fixing symbiosis is the ability form nodules. Nevertheless, these nodules need necessary organisation and ancillary machinery for N_2 -fixation (Giller, 2001). The second type of adaptations would therefore present a technical problem that has to do with how the ISFM technology works i.e. legume N_2 -fixation.

iii) The third and most important was convenient adaptation. Examples included the use of high quality resources, especially *Tithonia*, to speed up decay of other materials in a compost pit. It appears the few farmers practising this concept preferred routine rather than block, time-consuming and tiring practice. The same principle underlies the application of chicken manures in vegetable gardens, especially those behind the kitchen or residential houses. A different sort of example is soybean. Key informants said they would try to intercrop soybean with maize. This provides an important insight into how a new technology should fit

into existing cropping styles. It is an important test for suitability of soybeans as a soil fertility crop, especially in Emuhaya where average farm-plots are less than one acre (Republic of Kenya, 1997).

The most critical aspect will be the sourcing of *P*. *P* is essential in all plants, and necessary for legumes to grow well and fix N_2 (Giller, 2001). Results from the trials demonstrated this. Nevertheless, through informal interviews with non-participating farmers, a hitch about this was identified. This pit of fact was not making it to non-participating farmers or those who were not regular attendants of research meetings and learning process. It was realised that even the Swahili-boards placed on every demonstration site indicating the objective of the demonstration and what specific plots had, were not effective points of reference. Many farmers visited the demonstration-trials on their own and did not consult regular participants for any clarifications. As a result, researchers developed more detailed Swahili brochures that would later be distributed to as many farmers as possible.

Informal interviews, observation, *FGDs* and dialogue during field days showed that farmers generally wanted to plant soybeans and ground nuts due to their ability to “add fertiliser”. Few farmers had already planted soybean, but were interested in getting income besides soil fertility. These foregoing two examples of convenient adaptation showed three key farmer objectives, namely *a*) to see how a concept works at minimum conditions, *b*) to test whether a concept is flexible enough, especially if ‘loosely’ applied, and *c*) to enhance household income (in cases of commercial markets).

The need for scaling up

From early 1990s, scaling up has become an important research and development issue (Uvin and Miller, 1994). Scaling-up aims to provide more quality benefits to more people over a wider geographical area more quickly, more equitably and more lastingly (Gündel et al., 2001). Scaling up generally refers to increasing a program or initiative’s impact while maintaining its quality (IIRR, 2000; Proctor, 2003). Scaling-up can be geographical expansion to more people and communities, as well as institutional, involving expansion to other stakeholder groups and sectors (Ibid.; Pound et al., 2003). Uvin and Miller (1994) describe taxonomy of scaling-up that includes four broad categories

of quantitative, functional, political and organisational. The analysis in this paper is specifically directed at quantitative scaling, increasing the numbers of farmers reached in a qualitative way. Quantitative up scaling is also known as the geographical or spatial dimension in scaling up (IIRR, 1998; de Fliert et al., 1999).

Geographic coverage can be achieved through supporting community-level initiatives (Edward and Hulme, 1992; Hagmann et al., 1999; Kollavali and Kerr, 2002; LEISA, 2001). In the geographical as well as other dimensions sustainability, participation and capacity building are common themes (Loevinsohn et al., 1998; Franzel et al., 2001; Kolavalli and Kerr, 2002; Pound et al., 2003). Nevertheless, an omission in such literature is the obvious prerequisite, nature of the items to be scaled and their successful adoption.

There are three general strategies of scaling up. These are i) spontaneous scaling up, ii) scaling up after achieving initial local success, and iii) inclusion of the scaling up plan right from the start of project (IIRR, 2000). In an ideal situation, all these strategies are needed for better results. The FE initiative hopes to blend all these strategies to scale ISFM technologies; they are all inter-linked. This is the general TSBF’s approach of creating impact at the farm level through soil fertility research and enhancing farmers’ capacity to manage soil fertility through linking good science with adaptive research (TSBF, 2003).

Successful ISFM cases, although spreading on their own through the existing informal social structures may be further strengthened and expanded or scaled up with direct intervention (IIRR, 1998; ILEIA, 2001; Misiko, 2001). There are however institutional, political, socio-economic, technological and methodological factors that can keep the scaling up activities from realising their fullest potential of diversifying and spreading these benefits to more people more quickly (Harrington et al., 2001; Uvin and Miller, 1994). Overcoming these constraining factors is the overall challenge to the scaling up process. This paper specifically discusses technological facet of scaling ISFM initiatives.

ISFM technologies are mainly concepts that are knowledge extensive and/or demanding. As seen in the presentation above, there is a *challenge* inherent in the fact that the broader use of these concepts requires a scaling up of knowledge itself, which is not the case with the spread of more simple technologies or goods. This challenge means scaling ISFM has to be perceived as a process that is continuous and flexible. Unlike in material technologies where scaling replicates same

artefact elsewhere with measurable end-result, scaling ISFM can only be a continuous means and an end in itself.

Challenges and opportunities for scaling up ISFM technologies

In spite of the development and availability of excellent methods, technologies and a wide range of tools, the process of going to scale remains a hurdle (TSBF, 2003; Pound et al., 2003). The FE experiences and others show that challenges of scaling up ISFM technologies can be divided into four general sets of issues. These are:

i) Because ISFM addresses ecosystem properties and involves diverse stakeholders, transferring knowledge between scales must contend with and resolve the many potential clashes of expectations. A good example is the immediate need for food and the long-term soil fertility requirement. Farmers have differing perceptions and research is limited due to time constraints and other resources. It is also difficult to manage the diversity of farm situations relative to adaptive methods. Nevertheless, the key opportunity lies in the fact that ISFM can be fitted in diverse social situations for different needs, and demonstrating sustained impact may more effectively influence farmers (see also LEISA, 2001). As indicated earlier, this process should be seen as long-term.

ii) Problems are inherent in the fact that the broader use of ISFM concepts requires scaling up of knowledge itself, which is not the case with the spread of more simple technologies or goods. Results from *FGDs* and in-depth interviews showed that farmers' preference for a simple technology is well entrenched. According to farmers, a good technology may satisfy the simple minimum criteria of divisibility (being able to be used in bits); easy to apply – not laborious or requiring complicated learning processes; affordable; available in complete form or as material; can be predictable and easily recognisable in colour or shape; does not require many components to function; does what you want it to do and if it does others results are positive. Two key informants gave *Chrotolaria ochraleuca* as an example of a good technology. In addition, data from *FGDs* showed that participants classified well-maintained *FYM* as an ideal technology.

The experience of the FE presents us with the question, can the application of ISFM technologies, which

require extensive learning and consistency in use be scaled qualitatively? Do ISFM technologies have the capacity to spontaneously scale out? Adapted ISFM practices, results from interviews showed, were scaling out without the original (research) soil fertility concept. The new FE challenge is therefore, to identify, systematise and extrapolate few successful experiences to be able to make the jump from local/project level operations to scaled up operations. There may also be need to engage in more strategic research particularly within a research-and-development framework. This may mean working collaboratively with governments and other institutions that are able to shape the market for technological products i.e. not only in terms of empowering farmers but also convincing consumers about their value. In this case, market incentives may be catalytic in the use of ISFM technologies. Long term application of technologies, for instance groundnuts, results in accumulation of experience and generation of previously unknown skills and knowledge.

iii) As clearly shown above in the generated knowledge and practice and in the preceding paragraph, the adaptive development of ISFM technologies relies heavily on innovation and experimentation to tailor generic management technologies to diverse local conditions. That means, there can be as many adapted forms as possible. First, these forms are arguably more suited to each farmer's situation and may be highly irrelevant to his/her neighbours'.

Second, out of a basket of ISFM options that were disseminated, participating farmers were only picking ideas they found useful to their individual situations. That relied on farmers' own judgements. In addition, it was entirely upon participating farmers' own judgement to select the 'important' aspects for sharing with the rest. Each participant had a unique farm and social capacity. In scaling terms, this poses a challenge with regards to managing the complexity of ISFM systems, from merely knowing what innovations have occurred as presented earlier, to deciding which ones are worth reproducing, to understanding and targeting interventions to different parts of the systems. This is the basis of forthcoming study called "are ISFM concepts suitable for scaling up?"

iv) Conveying the numerous components and complexity of interactions involved in ISFM is very different from the extension of new crop varieties through demonstration plots. The results of crop varieties are quick and easy to see, whereas the results and possible benefits of ISFM may not be readily apparent and

often take time to manifest themselves. In addition, using ISFM-Ts and products does not necessarily mean one is applying the inherent soil fertility technologies. For instance, use of groundnuts and soybean may be known and even preferred regardless of their complex *germplasm*. They may be profitable and proliferate spontaneously.

However, informal interviews, initial key informant interviews showed no evidence that every bit of ‘user-information’ or the inherent soil fertility technologies accompanied soybean as they proliferated. For example, farmers needed to device ways of “knowing” when soybean was fixing *N*, or whether inoculation was needed. These were details that participating farmers were keen about. Nevertheless, these farmers did not judge these ‘pits of facts’ either as useful or ‘available’ to share, and therefore had not shared them with non-participating farmers. That presents a different sort of challenge, that of a technology (“hardware”) that seems preferable and simple, but with inherent details (“software”) that are vital for its functionality yet not adequately or obviously included in farmers’ conversations.

Another type of challenge resides in knowledge demanding technologies, for instance, the resource quality principle needs good grasp of detail to formulate, apply, for functioning of, and to manage products. There are no seeds to be offered, which for example farmers may use or pass on to others. For instance, farmers were merely expected to apply the *concept* of biomass transfer (e.g., *Tithonia*). In theory, resource quality concept or “software” is more usable in different ecological circumstances. But the knowledge demands interfere with this. It is hoped that the use of song, drama, brochures, common farmers’ experiments, and other innovative tools may reduce this problem. But it is not practical to standardise the knowledge generation process of farmers.

Conclusions

This review of ISFM technologies with regard to the issue of scaling up shows two vital lessons. One, that ISFM technologies are applied variedly. Their use results in a complex knowledge generation process amongst farmers, by building on the power of the natural sciences. Two, it is however, difficult to generate and extrapolate knowledge generation processes for scaling up. Farmers based their knowledge

generation procedures on the balance of possibilities after evaluation of the available evidence and long-term experience. Therefore, scaling up ISFM technologies must focus on research processes rather than facts, which lead to the impression that research is about certainties. Scaling up ISFM should consist of simple practical processes that farmers can understand, adapt and share with others while interacting with researchers. For instance, simple plots of screening grain legumes such as very promiscuous cowpea or soybeans. With time, local farmers may generate useful knowledge with regards to how these legumes respond to their highly varied soils. Such process needs long-term farmer empowerment and dialogue that leads to demystification of science from “known certainties and facts” to continuous processes that generate better opportunities.

Acknowledgements

We thank John Mukalama, Isaac Ekise, Anne Griffith all of TSBF-Maseno for their invaluable contribution in the FE initiative. We thank Walter Munywele of the Ministry of Agriculture in Vihiga for his role as a community facilitator in Emuhaya. We recognise and appreciate the special place of farmers in the FE initiative and their unique contribution of ideas. Special gratitude goes to the International Development and Research Centre of Canada for entirely supporting “Folk Ecology” through TSBF-CIAT.

References

- de Fliet E., Asmunati R. and Tantowijoyo W. 1999. Paper presented at the CIAT Workshop “Working with farmers: the key to adoption of forage technologies”, 12–15 October 1999, Cayagan de Oro, Philippines.
- Edwards M. and Hulme M. 1992. Scaling up NGO impact on development: learning from experience. *Development in Practice*. ISSN: 0961–4524. Editor: Deborah Eade. Volume 2, No 2.
- Franzel S., Cooper P. and Denning G.L. 2001. Scaling up the benefits of agroforestry research: lessons learned and research challenges. *Development: learning from experience*, volume 11, no 4, August.
- Giller K.E. 2001. *Nitrogen fixation in tropical cropping systems*. 2nd edition. Wallington: CAB International.
- Gündel S., Hancock J. and Anderson S. 2001. *Scaling-up strategies for research in natural resources management: a comparative review*. Natural Resources Institute (NRI), Chatham, UK. 61 pp.
- Haagmann J., Chuma E., Murwira K. and Connolly M. 1999. Putting process into practice: operationalising participatory extension. In, *Agricultural Research and extension Network paper 94*. July.

- Harrington, L., White, J., Grace, P., Hodson, D., Hartkamp, A.D., Vaughan, C and Meisner, C. (2001). Delivering the goods: scaling out results of natural resource management research. *Conservation Ecology* 5(2): 19.
- IFDC 2003. Integrated soil fertility management. Available at: www.ifdc.org/PDF_Files/ISFM%20Brochure.pdf (accessed March 14, 2004).
- IIRR 1998. *Sustainable agriculture extension manual for Eastern and Southern Africa*. Nairobi: International Institute of Rural Reconstruction.
- IIRR 2000. *Going to scale: Can we bring more benefits to more people, more quickly?* International Institute for Rural Reconstruction (IIRR), Silang, Cavite, Philippines.
- ILEIA Eds. 2000. Unleashing the Creativity of Farmers. ILEIA Newsletter, July, 2000. Centre for Research and Information on Low External Input and Sustainable Agriculture.
- Kolavalli S. and Kerr J. 2002. Scaling up participatory watershed development in India. IN, *development and Change* 33(2): Hague: Blackwell. Pp. 213–235.
- LEISA Magazine. OCTOBER 2001. Available from: <http://www.ileia.org/2/17-3/04-05.PDF> (Accessed on March 12, 2004).
- Loevinsohn, M., G. Meijerink, and B. Salasya. 1998. "Integrated Pest Management in Smallholder Farming Systems in Kenya." Kenya Agricultural Research Institute. Nairobi, Kenya.
- Misiko M. 2001. the potential of community institutions in dissemination and adoption of agricultural technologies in Emuhaya, Kenya. M.A. thesis. Nairobi: University of Nairobi.
- Pound P., Snapp S., McDougall C. and Braun A. (Eds.) 2003 *Managing natural resources for sustainable livelihoods*. London: Earthscan.
- Proctor F. 2003. Implementation of the Rural Strategy Scaling-up of development practice. Available from: http://www.worldbank.org/watsan/waterweek2003/Presentations/Session_Scalingup_WatershedManagementProjects/FelicityProctor_PPT.pdf (accessed March 14, 2004).
- TSBF-CIAT defines strategic direction for 2003-2007. 2003. *The Comminutor: Newsletter of the TSBF Institute of CIAT*. Nairobi: Kenya.
- Uvin P. and Miller D. 1994. Scaling Up: Thinking through the Issues. *World Hunger Program Research Report* 1994-1, available from: http://www.brown.edu/Departments/World_Hunger_Program/hungerweb/WHP/SCALINGU_ToC.html. (Accessed March 11, 2004).

Costs and Returns of Soil Fertility Management Options in Western Kenya

Paul L. Woomer

SACRED-Africa, P.O. Box 79, The Village Market, Nairobi 00621, Kenya, Email: plwoomer@gmail.com

Abstract

Several alternative soil fertility management options were compared in smallholders' croplands in western Kenya including "Green Revolution" fertilizer technologies (FURP), soil nutrient replenishment with rock phosphate (PREP), fortified composting (COMP), relay intercropping with *Lablab purpureus* (LABLAB), modestly-fertilized, staggered-row maize-groundnut intercropping (MBILI) and short-term improved *Crotalaria grahamiana* fallows (IMPFAL). These managements were established side-by-side on 140 farms in Western Kenya in 2002 and examined, along with a maize-bean control receiving no external inputs, over the next three growing seasons. Data were collected on crop yield, input costs, labor requirements and economic returns. Average maize yield ($LSD_{0.05} = 0.2$) ranged between 1.5 t ha^{-1} (No Inputs) and 2.8 t ha^{-1} (MBILI). Average legume yields ($LSD_{0.05} = 27$) ranged between 203 kg ha^{-1} (No Input bean) to 500 kg ha^{-1} (MBILI groundnut). Overall benefit:cost ratios ($LSD = 0.17$) were FURP (2.22) = No Inputs (2.28) < COMP (2.48) = LABLAB (2.52) < IMPFAL (3.03) < MBILI (3.44). Incomplete reports due to crop or experimental failure affected 31% of the farms. When all managements except the control were considered, modest or strong economic returns (benefit:cost > 2) were reported for 46% of the trials while economic loss or poor returns (benefit:cost < 2) were experienced by 23%. Clearly, all of these "recommended" technologies offer potential to many farms in Western Kenya, but the ability of farmers to provide the necessary input costs and labor remains uncertain

Key words: Africa, economic analysis, improved fallow, intercropping, legumes, maize

Agricultural research for whom?

Conventional wisdom maintains that food security in Africa will be achieved by presenting smallhold farmers with a "basket" of crop and land management options from which they may choose the practices that best suit their site-specific needs and socio-economic conditions (Lacy, 1996; Eicher, 1999). Western Kenya serves as a test of this wisdom where several different, and often competing, soil fertility management recommendations were developed and are being offered to farmers through a variety of outreach activities. These options include capital-intensive "Green Revolution" technologies, labor-and-resource-intensive "Organic" managements, land-extensive fallows and information-intensive (technically complex) "Integrated" solutions.

Ironically, Western Kenya's "basket" is full (to overflowing) but the smallholders' kitchen cupboards (if they had one) are too often bare, particularly during the persistent "hunger months" of March, April and May (Mukhwana, 2000).

Researchers cite weak extension, extensionists accuse non-cooperating farmers, farmers complain of insufficient financial and technical support while local administrators blame "ivory tower" scientists for failing to properly identify and package truly useful technologies. Much of this circular dilemma results from adherence to failing "top-down" models of dissemination because farmers are, at best, superficially involved in technology development and their later cooperation is taken for granted (Fujisaka, 1994). Furthermore, different "solutions" are often developed and field-tested

in isolation of one another, and frequently formulated upon ideological principles (and biases) rather than through iterative, agronomic problem-solving. It appears that research institutes and professional planners benefit most within this arena while the lives of most smallholder farmers remain unchanged or worsen. Furthermore, this situation suggests that we should focus more on how the “basket of options” is filled than how full it has become (Woomer et al., 2002).

That agricultural research has achieved less-than-desired impact does not necessarily compromise its technical merit (Patel, 2004). The infertile and nutrient-depleted soils of Western Kenya are well described (Sanchez et al., 1997; Smaling et al., 1997), as are the attempts to correct these soils using various organic resources and mineral fertilizers (KARI, 1994; Gachene and Kimaru, 2003; Woomer et al., 1998). Furthermore, several of these corrective technologies were captured in the form of extension manuals (Amadalo et al., 2003; Ndung'u et al., 2003; KARI, 2000; Tungani et al., 2002). A review of these materials allowed for the identification of several contrasting land management technologies intending to improve maize-legume intercropping, the most common food production and income generating enterprise in Western Kenya (Woomer et al., 1998).

Enter the contenders

FURP Recommendation. This treatment was obtained from Fertilizer Use and Recommendation Project (FURP) of Kenya Agricultural Research Institute (KARI, 1994). It is based upon several years of multi-location experiments using mineral inputs, relying on the use of nitrogen (N) and phosphorous bearing fertilizers at rates designed to optimize crop yields. Maize and beans are cultivated as intercrop in 37.5 cm alternating rows. About half of the urea or CAN is applied later as side dressing. This technology recommends application of 100 kg (2 bags) DAP and 50 kg urea applied before planting and an additional 100 kg CAN side-dressed after the second weeding, resulting in the addition of 66 kg N and 20 kg P ha⁻¹ per crop. During the second growing season, only the nitrogen side-dressing is applied.

PREP Package. This recommendation results from 4 years of experimentation by Phosphate Rock Evaluation Project (PREP) at Moi University

(Nekesa et al., 1999; Woomer et al., 2003). PREP-PAC is an integrated nutrient management package intended to ameliorate the low fertility patches symptomatic of nutrient depletion in Western Kenya. The package consists of Minjingu Phosphate Rock (MPR), urea, seeds, legume inoculant, gum arabic sticker, lime pellet and instructions, with MPR application intended to restore many years of soil phosphorous depletion. Maize and beans are cultivated as intercrops in 37.5 cm alternating rows. This management option recommends the use of 80 kg urea and 16 bags MPR per ha, equivalent to a one-time P replenishment of 100 kg ha⁻¹.

MBILI. This recommendation was obtained from SACRED Africa and is based upon a staggered intercrop row spacing and modest addition of nitrogen- and phosphorus-bearing (N&P-bearing) mineral fertilizers (DAP as a pre-plant at two 50 kg bags per ha and CAN as a side dressed applications at one 50 kg bag per ha). Alternating 50 and 100 cm rows allow for the cultivation of groundnuts within a wider-row interval (Woomer et al., 2002; Tungani et al., 2002).

Fortified Compost. This is a technology developed at Moi University. The technology involves utilizing low quality crop residue such as maize stover and wheat straw and the addition of small amounts of livestock manure and mineral fertilizers (Ndung'u et al., 2003). The technology recommends the application of 2 t ha⁻¹ of compost applied as a pre-plant application before the long-rains. The compost contains 2.2% N, 0.42% P and 1.4% K resulting in an addition of 44 kg N, 8.4 kg P and 28 kg K per ha and is applied during soil preparation for the long-rains (once per year).

Crotalaria Improved Fallow. This recommendation results from many years of research by the International Centre for Research in Agroforestry (Amadalo et al., 2003). A maize-legume intercrop follows one season's growth of *Crotalaria grahamiana* as a short-term improved fallow. After one season (usually the short-rains), crotalaria aboveground biomass is separated into two fractions; leafy twigs (fine branches) and the sticks (woody stems). The sticks are recovered and dried as cooking fuel. The leafy twigs are incorporated into the soil and, together with belowground biomass, constitute the sole inputs to the following maize-legume intercrop.

Lablab Relay Intercrop. This recommendation was obtained from KARI Legume Network and results from several years of testing various green manures and cover crops throughout Kenya (KARI, 2000; Mureithi et al., 2002). *Lablab purpureus* cv. Rongai is cultivated with maize in alternating 37.5 cm rows. Following first season maize harvest, lablab remains in the field, accumulating herbaceous biomass and symbiotically fixed-nitrogen, that is then incorporated into the soil for the following maize-legume intercrop.

Farmers' Bets. The Best Bet Network reserved one of the eight management options to be assigned by the local farmers' group or collaborating NGO. Each group of twenty farmers installed a management that they believed would be compatible with their farming operations and would provide a good return for their efforts as follows. In Bungoma, DAP was applied at 85 kg ha⁻¹ at planting (~ 15 kg N and 17 kg P) prior to the first and third seasons. In Busia, DAP was applied at 83 kg ha⁻¹ (~ 15 kg N and 17 kg P) prior to the first and third seasons or farmyard manure applied at 3.5 t ha⁻¹ prior to the first and third seasons. In Homa Bay, farmyard manure was applied at 6 t ha⁻¹ prior to the first and third seasons. In Kitale, DAP was applied at 167 kg ha⁻¹ (~ 30 kg N and 33 kg P) prior to the first and third seasons. In Siaya, a NPKS blend was applied at 167 kg ha⁻¹ (~ 28 kg N, 12 kg P and 28 kg K) prior to the first and third seasons. In Teso, locally gathered farmyard manure was applied at 4 t ha⁻¹ prior to the first and third seasons. In Vihiga, practices varied with individual farmers who applied various combinations of mineral fertilizer and domestic compost.

Independent assessment by NGOs

Six Non-Governmental Organizations collaborated to install 20 on-farm experiments each during three crop production seasons in their respective areas during 2002 and 2003. The core NGO members of the alliance were Sustainable Agriculture Centre for Research Extension and Development (SACRED-Africa) operating in Bungoma and Teso Districts, Resource Projects Kenya (Vihiga District), Environmental Action Team (Trans Nzoia District), Sustainable Community Oriented Development Project (Siaya

District), CARE-TASK (Homa Bay and other Nyanza Districts) and Appropriate Rural Development Agriculture Programme (Busia District). Each collaborator installed and managed 20 Best Bet trials during each of the growing seasons.

The general field protocol of these on-farm trials follows: Each cooperater identified 20 farms within each district. Eight 6 m x 10 m plots were marked and hand tilled to 20 cm. Adjacent plots were separated with a 1 m pathway. A composite soil sample from each of the plots was recovered to a depth of 20 cm and sent for analysis of total nitrogen, total soil organic carbon, pH and extractable P by the soil laboratory at Moi University (Okalebo et al., 2002). Treatment positions were randomized, fertilizers applied and locally-recommended maize and legume seeds planted in alternate or staggered rows at a maize plant population of 44,444 plants ha⁻¹. The MBILI treatment was established by planting single maize row along the plot boundary, then two 50 cm maize rows 1 m apart, and repeating this staggered spacing twice more, and then planting a final, single maize row along the other plot boundary. The trials were then farmer-managed, that involved hand weeding (x2) and, in the case of selected treatments, N side dressing. Maize and legumes were harvested at maturity, shelled, air-dried and weighed. Information was collected concerning farmers' labor requirements and local costs of farm inputs.

A data base was assembled at SACRED-Africa using Microsoft Excel from the field and laboratory analyses. Farms served as cases in rows and descriptive information and data were entered as columns. In addition to yield data, production costs, commodity prices, net returns and cost-to-benefit ratios were also entered. Cumulative as well as seasonal costs and returns were entered. The final data base contained 1120 cases (7 districts x 8 treatments x 20 farms), 52 columns and 58240 cells. The experimental design was a randomized complete block with individual farms constituting replicates. Effects were also partitioned for season and location (groups of 20 farms per district) using an ANOVA mixed model in the Genstat statistical package, a commercially available software product.

Thanks for the technologies but

These eight technologies were examined on 140 farms over three consecutive cropping seasons with special attention paid to input costs, labor requirements, crop

Table 1. On-farm comparison (n=100) of eight different recommended maize-legume intercrop managements (Best Bets) in Western Kenya over three continuous cropping seasons from February 2002 to July 2003

Management (n) ¹	long-rains 1		short-rains		long-rains 2		cumulative net return
	maize yield	legume yield	maize yield	legume yield	maize yield	legume yield	
	kg ha ⁻¹						(KSh ha ⁻¹)
no inputs (70)	1744	215	589	176	2116	217	27150
Lablab relay (63)	1749	n.c.	848	257	3195	374	32844
Compost (75)	2276	232	1112	245	3039	352	44520
<i>Crotalaria</i> fallow (73)	1847	238	n.c. ²	211	3585	380	46339
farmers' "bet" (58)	2242	240	1293	191	3566	437	51883
mineral fertilizer (77)	2618	287	1391	204	4031	414	55694
PREP package (71)	2679	316	1524	246	3322	485	55725
MBILI package (69)	2476	462	1583	312	4346	727	87939
LSD _{0.05} ^a	290	35	147	37	307	60	5771

¹(n) = number of farms reporting data for all three seasons.

² n.c. crop not planted.

^a LSD allows for yield comparison between managements within season.

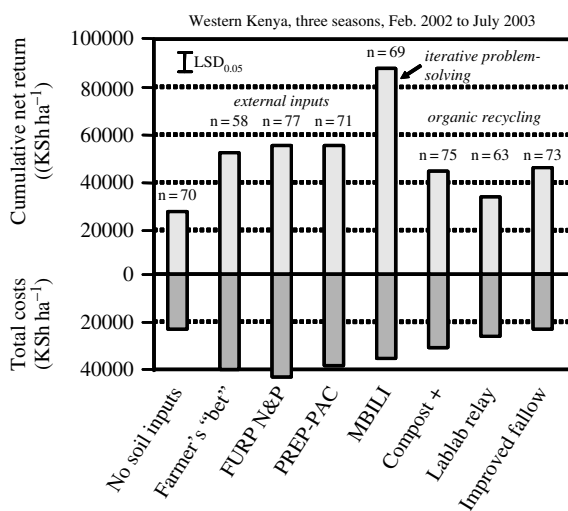

Figure 1. Total costs and cumulative net return from several Best Bet management options for maize-legume intercrops in Western Kenya (KSh 75 = US \$1).

yields and economic returns (Table 1, Figure 1). These findings, combined with informal discussions, allowed for the strengths and weaknesses of various practices to be identified, as well as the partitioning of similarities and differences in agronomic practices underlying various soil management technologies (Table 2). Direct comparison of Best Bet candidate technologies played an important role to popularize and demystify

the "basket of options" that had been independently developed by many agencies over several years.

All of the districts except one (Trans Nzoia) receive bimodal rains that allow for two cropping seasons. One of the six bimodal areas (Nyanza Province), suffered from moderate to severe drought during two cropping seasons and was therefore analyzed separately from the remaining trials. Thus, data was compiled for 100 Best Bet farms examining two trials per year for three consecutive cropping seasons (February 2002 to August 2003). In most cases, farms experiencing favorable benefit to cost ratios (≥ 2) were slightly less than half (Figure 2). These data, when expressed on a "per crop" basis averaged over three seasons (Figure 3), suggest that many farmers were exposed to several potentially useful, including one that requires low investment. At the same time, several farms found the trials too technically demanding or experienced negative or poor economic gains from these packaged Best Bet "solutions". Technology failure was often location or site specific. For example, lablab grew as a trailing understorey in most locations, but low light, drought and high temperatures induced this legume to assume a climbing behavior, one that often smothered intercropped maize. Applying mineral fertilizer or compost to conventional maize-legume intercrops increased the likelihood of economic loss or poor economic gain. The same was observed for nutrient replenishment with rock phosphate (PREP).

Table 2. Advantages and Disadvantages of the Technologies

FURP	<i>Advantages</i>	Fertilizers are easily transported and applied Immediate release of nutrients following application Plant deficiencies are quickly overcome or corrected.
	<i>Disadvantages</i>	Expensive investment for cash-poor smallholders Incorrect application may burn plants, especially seedlings
PREP-PAC	<i>Advantages</i>	Formulated from less expensive fertilizer sources Longer residual effects from rock phosphate Includes rhizobia inoculant to improve nitrogen fixation
	<i>Disadvantages</i>	Large initial investment & rock P not readily available Rock P is less soluble in some soils Intended for nutrient deficient patches not entire fields
MBILI	<i>Advantages</i>	Allows for wider selection of legume intercrops Reduces pests and diseases through legume rotation. Increases net returns and market access
	<i>Disadvantages</i>	Additional labour and tools required in field operations. Seeds of higher value legumes cost more
Lablab Relay Fallow	<i>Advantages</i>	Green manure is produced between growing Seasons Conserves soil and smothers weeds Produces edible green pods and seeds into the dry season
	<i>Disadvantages</i>	May reduce maize yields due to climbing habit Labor required for chopping and incorporating Opportunity lost to grow more valuable legumes
Fortified Compost	<i>Advantages</i>	Inexpensive source of plant nutrients. Better integrates crop and livestock enterprises Improves soil physical properties
	<i>Disadvantages</i>	Requires very large amounts of fresh organic materials. Final product may have very low nutrient concentration Production and transport is labor demanding.
Crotolaria improved fallow	<i>Advantages</i>	Organic inputs generated during short fallow interval. Weeds and striga smothered during the fallow interval. Woody stems provide stakes or cooking fuel.
	<i>Disadvantages</i>	Land diverted from crop production. Fallows attract new pests and diseases Leaves and fine stems are not used as livestock feed

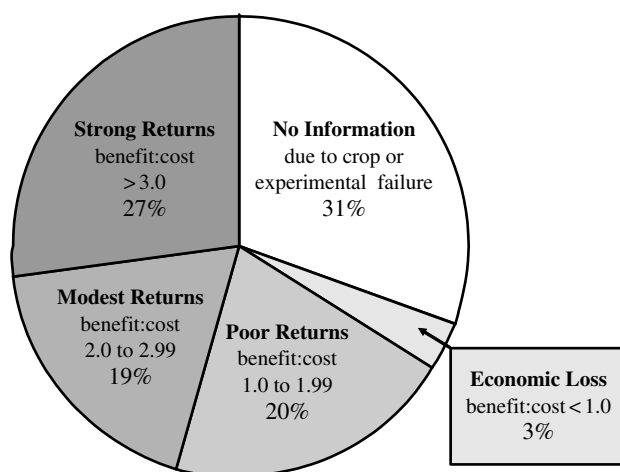

Figure 2. Economic returns to seven "Best Bet" soil management technologies over three cropping seasons on 100 farms in west Kenya.

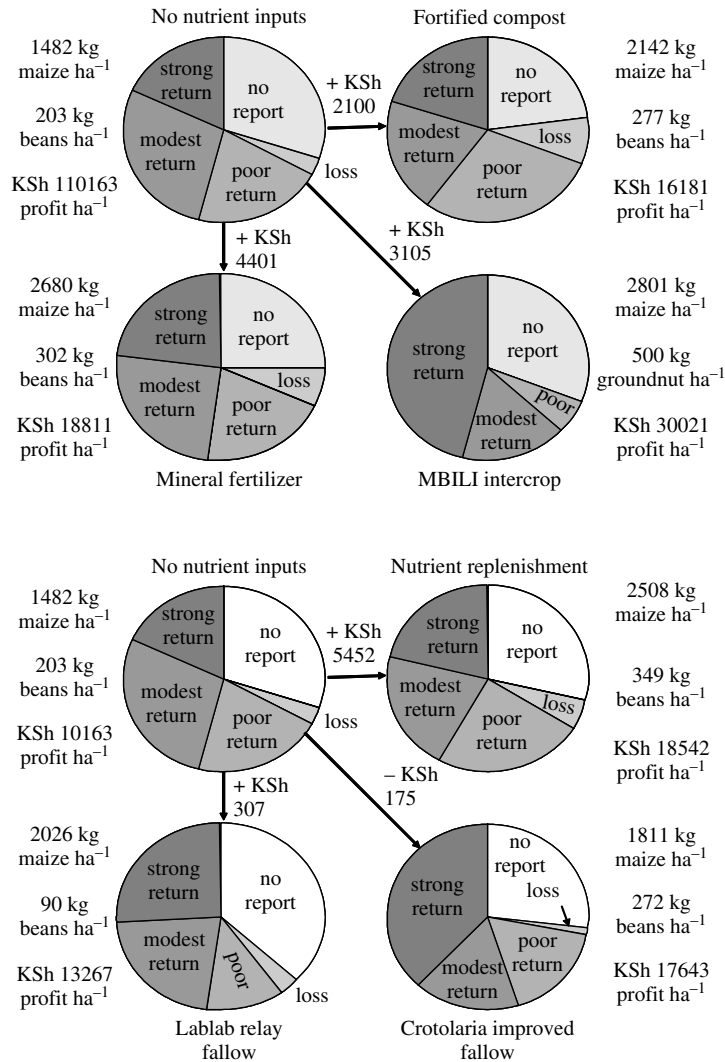

Figure 3. Risk accompanied soil fertility management strategies designed to improve maize-legume intercrop yield and profits during Best Bet trials on 100 farms in Western Kenya (data averaged per cropping season, KSh 75 = US \$1).

Soil characteristics and response to management

Some trends in soil characteristics were noted among the different farm categories. The chemical properties of the soils at the onset of the Best Bet trials appear in Table 3. Soil classifications are approximate and based upon a soil map rather than site profiles but note that many of the locations contain Acrisol/Ferralsol associations at different stages of weathering (Sombroek et al., 1982). Okalebo et al. (2002) described critically low threshold values for soil chemical properties in East Africa as pH < 5.2, total C < 1.5%, total N < 0.2%

and extractable P < 5.0 ppm With the exception of Nyanza , these soils tend to be weakly to strongly acidic, low in nitrogen and phosphorus and carbon-depleted. The heavier and higher soils contain more carbon, while the sandier and lower elevation soils contain less N.

Linear regression of soil properties in Western Kenya (excluding Nyanza and Trans Nzoia) revealed a moderate relationship between maize performance and soil organic matter and extractable P (Figure 4). FURP and MBILI were shown to be particularly responsive in soils high in soil carbon, and a smaller response noted

Table 3. Soil pH, total organic carbon and macronutrient contents prior to the onset of the Best Bet trials in February 2002. Classification after Sombroek et al., 1982

Location	soil				classification (FAO)
	pH (1:2.5)	total C (%)	total N (%)	ext.P (ppm)	
Bungoma	5.6	1.4	0.18	4.8	orthic Acrisols and Ferralsols
Busia	5.1	1.0	0.27	4.0	orthic Ferralsols w/ironstones
Nyanza	6.8	2.3	0.43	19.8	ferralic Cambisols
Siaya	4.8	1.6	0.17	3.3	orthic to rhodic Ferralsols
Teso	5.7	0.7	0.09	6.6	orthic Ferralsols and Acrisols
Trans Nzoia	5.3	2.0	0.27	3.5	rhodic Ferralsols
Vihiga	4.8	1.2	0.16	3.3	feralo Acrisols/orthic Ferralsol
LSD _{0,05}	0.4	0.4	0.01	4.8	

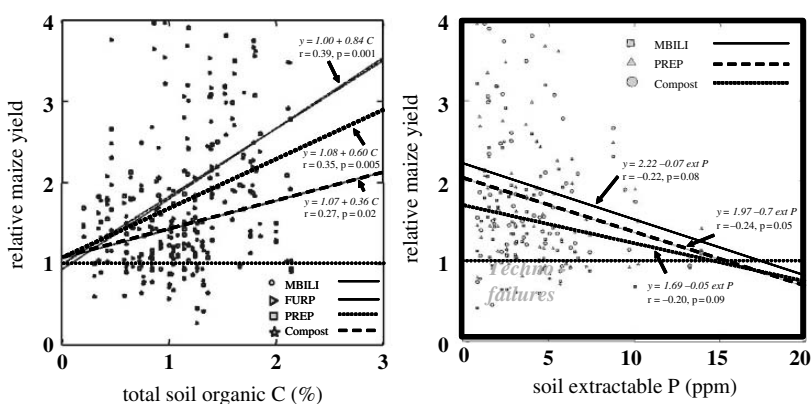

Figure 4. Linear regression of relative maize yield (treatment yield/control yield) suggests that soil organic matter and available phosphorus regulate the success of several Best Bet technologies.

for the addition of compost. Indeed, applying compost to a soil rich in soil organic matter may be considered a redundant practice (Figure 4, left). Some technologies perform more poorly as soil phosphorus increased, suggesting that phosphorus is not required beyond a certain threshold. An analysis of data in Figure 4 (right) suggests that the critical threshold of extractable P is 15 ppm, 50% higher than that proposed by Okalebo et al. (2002), and that PREP or fertilized MBILI will no longer be necessary under these conditions. Note that many locations result in a negative (less than 1.0) response to inputs, but, given the extensive nature of this investigation, we were unable to attribute definitive cause to this conditions. Field observations and farmer comments suggest that many of these locations were affected by striga (Siaya and Teso), and that others were shallow (Teso) and poorly drained fields. Another trend was noted for lablab, it tended to perform poorly in soils

with lower pH and soil organic C (data not presented). This trend suggests that lablab fallows have difficulty in establishing in the more infertile and depleted soils.

Conclusions

Clearly, all of these “recommended” technologies offer potential to many farms in Western Kenya (Table 1), but the ability of farmers to provide the necessary input costs and labor remains uncertain (Figure 2). That a majority of trials (54%) resulted in experimental or crop failure, or in less than satisfactory economic returns suggests that we should focus on how the farmers’ “basket of options” is filled rather than on how full it has become. Overall, only two of the seven technologies offered improvement on over 50%

of the farms. The crotoalaria improved fallow raises average crop yields by avoiding short-season maize cropping and reducing production costs. In essence, it provides slightly more at lower out-of-pocket expense. MBILI was designed through iterative problem-solving (Woomer, 2004), but requires a modest investment. It is based upon the cultivation and marketing of higher value crops other than beans while beans are the farmers' preferred legume intercrop for home consumption. Both of the technologies demonstrated real potential for different socio-economic situations in Western Kenya, but neither may be regarded as a blanket solution. On a more positive note, farmers were provided an excellent opportunity to familiarize themselves with a wide range of new maize-legume cropping practices and personal observation indicates that most farmers took full advantage of this situation. What we must do as scientists and rural development specialists is learn to do the same in a more documented manner. We must better develop our capacities to combine, or FUSE, the advantages of different technologies in a manner that better tailors their application within a wider range of farmers' capacities, agro-environments and socioeconomic conditions. Hence, the need for a *Best Bet Fusion*.

fusion *n* something new created by a mixture of qualities, ideas or things

(Collins English Dictionary)

But how may this Best Bet Fusion be achieved? It is akin to replacing top-down models of technology dissemination with more interactive and participatory ones (Lacy, 1996). It requires that we better synthesize indigenous and scientific farming systems knowledge (den Biggelaar, 1991). We must sequentially partition a given set of management alternatives into their component aspects, recombine them and then appreciate them in a holistic, integrated manner. For example the Best Bet options may be separated into their nutrient management and larger agronomic components (e.g., field operations not directly related to supplying nutrients to crop plants) and compared within an opportunity matrix, and that the most promising combinations are limited (31% of all possible combinations) and may be prioritized. (Figure 3). Finally, we must stand prepared to divorce ourselves from professional and ideological biases, and treat each promising fusion as legitimate unless sufficient evidence exists to dismiss one fusion in favor of an alternative technology.

Acknowledgement

Several individuals and organizations offered research backstopping and logistical support to this work including Winslaus Khaoya and Johnstone Odera Tangani of SACRED-Africa, Mary Kifuku and Keziah N'dungu of the Soil Science Department of Moi University, Joseph Mureithi from the Legume Research Network of the Kenya Agricultural Research Institute, Bonface Wamalwa from the Sirityanyi Farmers Field School, Jennifer E'tiang of the St. Marks Women Group (Teso) and Quresh Nordin of the World Agroforestry Centre (formerly ICRAF).

References

- Amadalo B., Jama B., Niag A., Qureish N., Nyasimi M., Place F., Franzel S. and Beniast J. 2003. Improved fallows for western Kenya: an extension guideline. Nairobi. World Agroforestry Centre (ICRAF). 48 pp.
- den Biggelaar C. 1991. Farming systems development: Synthesizing indigenous and scientific knowledge systems. *Agriculture and Human Values* 8:25–36
- Eicher C.K. 1999. Institutions and the African Farmer. CIMMYT Economics Program Third Distinguished Economist Lecture. CIMMYT. Mexico.
- Fujisaka S. 1994. Learning from six reasons why farmers do not adopt innovations intended to improve sustainability of upland agriculture. *Agricultural Systems* 46:409–425.
- Gachene C.K.K. and Kimaru G. 2003. Soil Fertility and Land Productivity. RELMA, Nairobi. 146 pp.
- Kenya Agricultural Research Institute (KARI). 1994. Fertilizer Use Recommendations; Volumes 1–22. Kenya Agricultural Research Institute, Nairobi.
- Kenya Agricultural Research Institute (KARI). 2000. Soil Fertility Management Handbook for Extension Staff and Farmers in Kenya. KARI Technical Note Series No. 6. 45 pp.
- Lacy W.B. 1996. Research, extension, and user partnerships: Models for collaboration and strategies for change. *Agriculture and Human Values* 13:33–41.
- Mukhwana E.J. 2000. Food security and the impact of agricultural development in Kenya: problems and opportunities. *Agricultural Research and Extension Newsletter* 41:21–26.
- Mureithi J.G., Gachene C.K., Muyekho F.N., Onyango M., Mose L. and Maganya O. 2002. Participatory Technology Development for Soil Management by Smallholders in Kenya. KARI Legume Network Project, Nairobi. 551 pp.
- Ndung'u K.W., Kifuku M.N. and J.R. Okalebo. 2003. Producing fortified compost from crop residues. In: C.E.N. Savala et al. (Eds) *Organic Resource Management in Kenya*. FORMAT, Nairobi. pp. 71–74.
- Nekesa P.O., Maritim H.K., Okalebo J.R. and Woomer, P.L. 1999. Economic analysis of maize bean production using a soil fertility replenishment product (PREP-PAC) in western Kenya. *African Crop Science Journal* 7: 157–163.

- Okalebo J.R., Gathua K.W. and Woomer P.L. 2002. Laboratory Methods of Soil and Plant Analysis: A Working Manual. Second Edition. SACRED-Africa, Nairobi. 128 pp.
- Patel B.K. 2004. Chapter 2.2. Research for Whom. In: B.K. Patel, K. Muir-Leresche, R. Coe and S.D. Hainsworth (Eds.) *The Green Book: A Guide to Effective Graduate Research in African Agriculture, Environment and Rural Development*. The African Crop Science Society, Kampala, Uganda. pp. 29–36
- Sanchez P.A., Shepherd, K.D., Soule M.J., Place F.M., Buresh R.J., Izac A-M.N., Mokwunye A.U., Kwesiga F.R., Ndiritu C.G., and Woomer P.L. 1997. Soil fertility replenishment in Africa: An investment in natural resource capital. In: R.J. Buresh et al. (Eds.) *Replenishing Soil Fertility in Africa*. SSSA Special. Publication No. 51. SSSA, Madison, WI. pp. 1–46.
- Smaling E.M.A., Nandwa S.M., and Janssen B.H. 1997. Soil fertility in Africa is at stake. In: R.J. Buresh et al. (Eds.) *Replenishing Soil Fertility in Africa*. SSSA Spec. Publ. 51. SSSA, Madison, WI. pp. 47–61.
- Sombroek W.G., Braun H.M.H. and van der Pouw B.J.A. 1982. Exploratory Soil Map and Agro-climatic Zone Map of Kenya. Kenya Soil Survey Report No. E1. National Agricultural Research Laboratories, Nairobi. 56 pp. + maps.
- Tungani J.O., Mukwana, E. and Woomer P.L. 2002. MBILI is number 1: A handbook for innovative Maize-Legume intercropping. SACRED Africa, Bungoma, Kenya. 20 pp.
- Woomer P.L. 2004. Chapter 2.3 Approaches to impact-oriented agricultural research. Pp. 37–50. In: B.K. Patel, K. Muir-Leresche, R. Coe and S.D. Hainsworth (Eds.) *The Green Book: A Guide to Effective Graduate Research in African Agriculture, Environment and Rural Development*. The African Crop Science Society, Kampala, Uganda.
- Woomer P.L., Mukhwana E.J. and Lynam J.K. 2002. On-Farm research and operational strategies in soil fertility management. In: B. Vanlauwe, N. Sanginga and R. Merckx (Eds.) *Integrated Plant Nutrient Management in Sub-Saharan Africa* CABI, Wallingford, UK. pp. 313–331
- Woomer P.L., Bekunda M.A., Karanja N.K., Moorehouse T. and Okalebo J.R. 1998. Agricultural resource management by smallhold farmers in East Africa. *Nature and Resources* 34 (4):22–33.
- Woomer P.L., Okalebo J.R., Maritim H.K., Obura P.A., Mwaura F.M., Nekesa P. and Mukhwana E.J. 2003. PREPAC: a nutrient replenishment product designed for smallholders in western Kenya. *Agriculture, Ecosystems and Environment* 100:295–303.

Modeling farmers' decisions on integrated soil nutrient management in sub-Saharan Africa: A multinomial Logit analysis in Cameroon

Guy Blaise Nkamleu

International Institute of Tropical Agriculture, B.P. 2008, Messa-Yaoundé, Cameroon; Fax: (237) 2 237437,

E-mail: g.b.nkamleu@cgiar.org

Abstract

Much of the technical work on integrated soil nutrient management in sub-Saharan Africa has not considered the determinants of farmers' adoption decisions. It is important that technical research on these integrated soil nutrient management options be guided by consideration of the factors that determine farmers' decisions to combine organic and inorganic nutrients. Economists investigating consumer demand have accumulated considerable evidence showing that the observed decision choice on an agricultural technology is the end result of a complex set of inter-technology preference comparisons made by farmers.

This study analyzes the factors that affect farmers' decisions to adopt different soil nutrient management practices in Cameroon. The technologies evaluated are inorganic fertilizers, organic fertilizers, and combine use of organic and inorganic fertilizers. A Multinomial Logit model was used to capture choice probabilities across these soil nutrient management categories. Data from a random survey of 217 peri-urban farmers are used in the investigation. The results show that the factors affecting farmers' choices across the soil nutrient management categories are different and should be taken into consideration in efforts to promote integrated soil nutrient management practices within agroecosystems in rural areas of Cameroon. The study ends by raising a number of implications for strategies to promote integrated soil nutrient management among peri-urban gardening and fruit tree farmers in Cameroon

Key words: Cameroon; inorganic fertilizers; Multinomial Logit; nutrient management; organic fertilizers; Soil fertility

Introduction

The major challenge facing agriculture in many parts of sub-Saharan Africa is how to increase farm production to meet changing food needs without degrading the natural resource base. A factor that limits sustainable productivity increases is the inherent low fertility of the soils. The fertility status of the soils in the region is manifested by high soil acidity, aluminum toxicity, low nutrient reserves, nutrient imbalances and multiple nutrient deficiencies of low activity classes such as *Ultisols* and *Oxisols* (Nair 1993; SMSS 1986), and high levels of susceptibility to erosion, crust- ing and acidification of the *Alfisols* (Sanchez 1976).

Rapidly shortening fallow -a result of high demographic pressure- threatens the ecological sustainability of slash-and-burn agricultural systems (Kleinman et al. 1995; Smaling et al. 1993).

Although the use of chemical fertilizers can help improve the fertility of these soils, the amounts used by farmers are extremely low, averaging less than 10 kg of fertilizer nutrients per hectare in sub-Saharan Africa (Pretty 1995). Even with the supplementary use of chemical fertilizers, crop yields have been found to decline under continuous cultivation due to declining of organic matter levels under continuous cultivation (Kang et al. 1995; FAO 1985; Moormann and Greenland 1980). In several parts of sub-Saharan

Africa, the food production strategy preferred by governments has been the widespread promotion of inorganic fertilizers. Coupled with the use of high levels of fertilizer subsidies and subsidized interest rates on smallholder agricultural credit, several countries experienced positive growth rates in food production in the 1980's. In some countries like Malawi and Zimbabwe, the use of hybrid maize and fertilizers became widespread. But with the implementation of structural adjustment programs, currencies were devalued and markets for inputs were liberalized, increasing the prices of chemical inputs substantially, often rising to several times the grain prices. The rising fertilizer-grain price ratio led to a substantial decline in the use of inorganic fertilizers, and the collapse of the so called "green revolution" in Malawi (Carr 1997) and in other parts of sub-Saharan Africa. It is now widely recognized that for sustainable food production, efforts must now be directed towards other sources of soil nutrients. Given the potential adverse effects of chemical fertilizer on the environment, strategies for soil nutrient management on tropical soils have increasingly focussed on integrated soil nutrient management technologies (FAO 1991, cited in Conway 1997). This involves the combined use of both organic and inorganic soil nutrient sources, including biological nitrogen fixation, crop rotations, cereal legume intercrops, improved fallows, composting, green manuring, animal manure, and chemical fertilizers (Waddington et al. 1998; Conway 1997; ICRAF 1996; Nair 1993). Such strategies rely on the use of nutrients that are both external and internal to the farm agroecosystems, with particular emphasis on better nutrient cycling and lowering the costs of soil nutrient management.

Farmers already use animal manure, green manure, composts and chemical fertilizers, often in an integrated manner, for the maintenance of soil fertility. But socio-economic ex-post adoption studies of integrated soil fertility practices of farmers in West and Central Africa are few (Matlon 1994; Kabore 1988; Prudencio 1983). A larger number of studies have examined the use of chemical fertilizers with the objective of better targeting chemical fertilizer-based interventions in farming systems (Adesina 1996; Posner and Crawford 1992; Hailu 1990; Daramola 1989; Kelly 1988; Falusi 1975). Although more limited, studies of farmers' use of organic nutrient sources, especially animal manure, have also been conducted in areas where there exist important crop livestock interactions (Coulibaly 1995; Siridie and Giraudy 1994; Matlon 1994; Williams et al. 1993; Adesina 1992; Prudencio 1983). Many authors

have argued that there is need to consider complementary use of organic and inorganic nutrients in strategies for soil fertility improvement (Conway 1997; Matlon and Adesina 1997; Sanders et al. 1996; Matlon 1994; Adesina 1992; Bationo and Mokuwunye 1991).

Current efforts to promote the use of integrated soil nutrient management among farmers in East and Southern Africa have shown that there are some scope for reducing the use of inorganic fertilizers by optimal combination of organic and inorganic inputs (Waddington et al. 1998). However, much of the technical work on integrated soil nutrient management in sub-Saharan Africa has not considered the determinants of farmers' adoption decisions. It is important that technical research on these integrated soil nutrient management options be guided by consideration of the factors that determine farmers' decisions to combine organic and inorganic nutrients. This paper seeks to help fill this gap.

Several studies that examined the determinants of farmers' decisions to adopt soil fertility management technologies have focussed on one technology (Adesina 1996; Daramola 1989; Falusi 1975). In studies where more than one technology was considered (Matlon 1994; Hailu 1990; Kabore 1988; Prudencio 1983), the analytical methods used did not permit the integrated analysis of decision probabilities across different soil nutrient management categories. Because farmers' decisions on organic and inorganic soil nutrient management strategies may be interdependent – as they both require the use of cash and/or labor, both of which are limiting, smallholder farm models used to examine farmers' adoption decisions should consider adoption decisions across input categories in an integrated manner. It has been maintained out that to achieve sustainable production increases without depleting soil nutrient resources, it will be increasingly important to consider integration of these nutrients, with particular attention to the agronomic, ecological and socio-economic factors in decision making (Conway 1997).

The objective of the paper is to assess the factors that affect farmers' choices between organic, inorganic sources of nutrients, and integrated soil nutrient management in Cameroon. A multinomial Logit model (Cramer 1991; Maddala 1983) is used to capture decision choices across these alternative strategies. The paper is divided into five sections. Section two discusses the survey methods and analytical model. Section three presents the empirical model specification, while section four discusses the results. The paper ends

in section five with conclusions and recommendations for improving farmers' use of integrated soil nutrient management within their agroecosystems.

Materials and methods

Survey

To examine farmers' use of different soil nutrient management strategies, a survey was conducted in two peri-urban areas of Cameroon from August to December of 1995. The survey covered a total of 217 farmers randomly selected in the zones of Yaounde (82 farmers) and Bafoussam (135 farmers). The two zones are different in terms of agroecological factors, farming systems, degree of urbanization and population density. Yaounde is situated at 730 m altitude, in the forest margin. Rainfall is high and varies between 1,500 mm to 2,000 mm per year. The major crops consist of industrial cash crops (primarily cocoa), and food crops like cassava, maize, cocoyams and groundnuts. Fruit trees are important in the home gardens (Tchatat 1996), while the development of horticultural crops is intensive in peri-urban areas. The group of farms surveyed here is representative of home gardens and peri-urban horticulture farms. Bafoussam is located in the western highlands, with an altitude of 1,500 m. Soils are ferralitic, and cropping systems are highly diverse, with the major crops being maize, beans, and cassava. Farmers also cultivate coffee in plantations. Livestock, mainly small ruminants (pigs, goats and sheep), are important in this zone.

Although reliable national statistics are unavailable, the use of composts by farmers is believed to be increasing in these peri-urban areas in Cameroon. Commercialized composts are made from recycled urban wastes and sold to farmers in peri-urban areas in small packages, as well as in 25 kg and 50 kg bags. In addition, farmers use decomposed plant material, kitchen refuse, and household wastes. These are often left in heaps around the household and left to decompose. The decomposed material is then applied to fields differentially, depending on the type of field (home garden or food crop field), cropping history and distance of the fields to the homestead. Farmers also burn vegetation and apply ash. They also perform direct application of animal refuse, crop residues and household waste. Almost all farmers make direct applications of refuse and residues. In this study, the analysis excludes those

cases and organic fertilizer is referred here to composts (bought or self manufactured).

A first rapid Rural Appraisal (RRA) was used to assess the utilization patterns of the lands in the two above-mentioned peri-urban zones. This was followed by a detailed household survey to identify relevant agroecological factors (cropping systems, land, water and soil fertility management strategies etc.), and socioeconomic characteristics of farmers.

A list of farmers established from the RRA allowed the opportunity of selecting households randomly, with known probability of selection.

Analytical model

Few studies have been made of how farmers make soil fertility decisions in SSA. Orasanu and Connolly (1993) claim that most research on decision-making has focused on the decision event, not the process. According to Ohlmer et al. (1998), current knowledge of the decision making process can be described as a set of eight functions or elements: values and goals, problem detection, problem definition, observation, analysis, development of intention, implementation, and responsibility bearing.

More recently, using psychological concepts, Nuthall (2001) argued that understanding decision capability requires more than a study of the decision processes used (e.g. as reported by Ohlmer et al. (1998). The study of learning and thinking processes (cognitive psychology) is relevant and related to managerial ability. That is, it must be clear how humans observe information, how information is stored and retrieved, how it is processed and so on. These processes are assumed to be inherent/implicit in the decisions made by farmers in modeling decision making.

Economists investigating consumer demand have accumulated considerable evidence showing that the observed decision choice on an agricultural technology is the end result of a complex set of inter-technology preference comparisons made by farmers (Ohlmer et al. 1998). Despite all the development in decision theories by anthropologists, sociologists, philosopher, farmers still largely rely on perception and intuition to make a decision (Nuthall 2001; Ohlmer et al. 1998).

Variables which affect farmers' access to information, and hence their perception (e.g. extension, education, media exposure, individual characteristics, etc.), are typically used in economic models of the determinants of adoptions (Polson and Spencer 1991;

Kebede et al. 1990). Several empirical studies have tried to capture the influence of socioeconomic variables on farmers' adoption decisions. In most cases, the use of Probit or Logit model is applied (Nkamleu 1999; Adesina 1996; Hailu 1990; Kebede et al. 1990; Rahm and Huffman 1984). In these models, farmers are assumed to make adoption decisions based upon an objective of utility maximization.

A multinomial Logit model (Nkamleu and Coulibaly 2000; Cramer 1991; Madalla 1983) is applied in this analysis. The advantage of multinomial Logit is that it permits the analysis of the adoption decisions across the various soil fertility management alternatives – allowing the determination of choice probabilities for different categories of soil nutrient management practices. This approach is more appropriate than Probit or Logit models which have been conventionally used in studies of farmer's adoption of soil fertility management practices (Hailu 1990; Daramola 1989), when there exist multiple soil nutrient management strategies. No study in West and Central Africa has applied the multinomial logit to analysis of farmers' soil nutrient management decisions.

Instead of having two dichotomous (0, 1) alternatives as in the multi variate Logit or Probit models, the Multinomial Logit has S possible states or categories that is $s = 1, 2, 3 \dots, S$, – which are disjunct and exhaustive (Cramer 1990).

In the analysis of the adoption of soil nutrient management systems in this study we consider four categories, namely, 1) farmer uses no organic or inorganic fertilizers, 2) farmer uses only chemical fertilizers, 3) farmer uses only organic fertilizers (defined as composted material made from decomposed plant material, kitchen refuse, and household waste), and, 4) farmer uses both organic and inorganic fertilizers (referred to henceforth in the paper as “integrated soil nutrient management”).

Because the multinomial Logit model does not treat these nutrient management categories in any continuous order, it is different from ordered Logit or Probit models (Ameniya 1981).

Let there be a random sample of farmers, $I = 1, 2, 3 \dots, N$. Given four alternatives soil fertility management strategies, $s = 1, 2, 3, 4$, the multinomial logit model of soil nutrient management assigns probabilities P_{is} to events characterized as “ i^{th} farmer in s^{th} category”. Let the vector of characteristics of the farmers be denoted by x_i . Following Cramer (1991), define Y^i as a vector of S categories in which there is a single nonzero element, and another vector I_s having

zeros everywhere but 1 at the s^{th} location. The event that the I^{th} farmer is found in the s^{th} nutrient management category or state can then be given as $Y_i = I_s$, with the probability $P_{is} = P_r(Y_i = I_s)$, for $s = 1, 2, 3, 4$. The multinomial probability model of soil nutrient management is then represented as $P_{is} = P_s(x_i, \Theta)$, where Θ are unknown parameters to be estimated. To estimate this model there is need to normalize on one soil nutrient category, which is then referred to as the soil nutrient “reference state”. In this analysis we take the first category, i.e., farmers that do not use any fertilizers whether organic or inorganic as the “reference state”. The multinomial probability model for soil nutrient management decisions across S states ($s = 1, 2, 3, 4$) can then be specified as:

$$P_s = (X_i, \Theta) = \exp(X_i^T \beta_s) / (1 + \sum_t \exp(x_i^T \beta_t)) \quad (1a)$$

for s not equal to 1

$$P_1 = (X_i, \Theta) = 1 / (1 + \sum_t \exp(x_i^T \beta_t)) \quad (1b)$$

Models (1a) and (1b) are used for the estimation of the multinomial soil nutrient management model. The Multinomial Logit model of investment in soil nutrient management technologies was estimated using LIMDEP© (Green 1992).

Empirical model

An empirical specification is employed to investigate the relationship between socio-economic characteristics and the use of inorganic and organic fertilizers. Descriptions of variables included in the empirical model are given in Table 1. The discussion and justification for the independent variables included in the model are provided below.

EXP measures the number of years of farming experience of the farmer. With experience it is expected that farmers will be able to better assess the differential benefits of organic and inorganic inputs, and to apply optimal (financially) levels of inputs across their fields. It is hypothesized that EXP is positively related to the utilization of organic and inorganic fertilizers, and the use of both in a combined fashion.

GROUP measures whether or not the farmer belongs to a farmer's cooperatives. Since farmers in local organizations are more likely to be in contact with research, development and extension agencies, they are more likely to adopt innovations. Studies in Cameroon have

shown that farmers belonging to farmers' organizations had significantly higher likelihood of adopting alley farming (Adesina et al. 2000). It is hypothesized that GROUP is positively related to adoption of inorganic, organic, and integrated soil nutrient management.

AREA measures the cultivated area by the farmer in square meter. The effects of farm size on the use of new innovations is generally related to economies of scale effects or lower acquisition costs by large farmers due to preferential access to inputs and credit (Polson and Spencer 1990; Norris and Batie 1987). However, for organic and inorganic fertilizers, economies of scale effects are not likely to occur. Due to high costs of chemical fertilizers following the devaluation of the currency and the removal of input subsidies, acquisition costs have risen substantially. Besides, farmers with large farms may also have sufficient land to put some under fallow as a method of soil fertility maintenance. It is hypothesized that AREA is negatively related to the use of organic and inorganic fertilizers, and integrated soil nutrient management.

EXT measures the frequency of contacts by the farmer with extension agents. Contact with extension improves farmers' technology understanding, perception of profit potential (Nkamleu 1999). Because the application of organic inputs, and especially integrated nutrient management is more knowledge based, than the use of inorganic fertilizers, farmers in contact with extension agents may be better able to manufacture and apply appropriate quantities of composts, and organic and inorganic fertilizers. It is hypothesized that EXT is positively related to the adoption of inorganic, organic fertilizers, and integrated soil nutrient management.

EDUC measures the level of education of the farmer. The effect of education on farm productivity and efficiency has been intensely debated (Shultz 1975). Studies in developed agriculture have shown that education improves allocative efficiency of farmers and farm productivity. Huffman (1974) found that educated farmers were better able to adjust to disequilibria created by the introduction of nitrogen fertilizers for hybrid corn in Iowa, by adjusting nitrogen application levels to shifts in relative factor prices. Studies in developing countries with smallholder agriculture have found that farmer education significantly affects productive efficiency among smallholder farmers (Rahm and Singh 1988). Given that integrated soil nutrient management technologies are knowledge-based, it is expected that education will enhance the probability of adoption of such technologies. A recent study by Nkamleu and Adesina (2000) showed that the level of education positively

affects the acceptance of chemical fertilizer in peri-urban lowland systems of Cameroon. It is hypothesized that EDUC is positively related to the adoption of inorganic, organic fertilizers, and integrated soil nutrient management relative to the reference state.

LVSTOCK indicates if the farmer keeps livestock. Farmers with livestock may be better able to take advantage of animal manure for soil fertility management on their fields (William et al. 1993). Because farmers using livestock manure are less likely to buy chemical fertilizers, a negative relationship is hypothesized with the adoption of inorganic fertilizers. Farmers with access to livestock manure are also less likely to buy composts since both inputs are substitutes.

FMSIZE measures households' family size. Family labor is the most important source of labor supply for farm households. While labor is hired for activities such as field clearing, application of organic and inorganic inputs rely exclusively on family labor inputs. Due to the high labor demands for applying organic and inorganic fertilizers, the larger the family size the higher the labor available for application of these inputs. It is hypothesized that FMSIZE is positively related to the adoption of organic and inorganic fertilizers, and of integrated soil nutrient management practices .

SEX indexes the gender of the farmer (0 = female, 1 = male). In an analysis of the adoption of chemical fertilizers by rice farmers in Cote d'Ivoire, Adesina (1996) found that women's rice fields were less likely to receive chemical fertilizers than men's fields – reflecting the effects of capital constraints faced by women. In Burkina Faso, Matlon (1994) found that men generally had greater likelihood of adopting animal manure and inorganic fertilizers on their fields than women. However, in Cameroon, the majority of the food crop fields are managed by women. Also, because women are in charge of the collection of household refuse for use as composts, it is expected that the probability of their use of organic composts will be higher than those of men. It is therefore hypothesized that SEX is positively related to decision choices for organic fertilizers, but negatively related to decisions for inorganic fertilizers.

ASSET is the capitalized value of agricultural mechanic equipments and is an index of capital assets available to the farmer. Given that there is a positive correlation between capital assets and wealth, farmers with higher asset values are more likely to have financial resources for investments in soil fertility management technologies. It is hypothesized that ASSET is positively related to the adoption of

Table 1. Descriptive Statistics for Variables in Empirical model

Variable	Description	Mean	Standard deviation
EXPE	Years of farming experience.	13.544	11.47
GROUP	Whether or not the farmer belongs to a farmers' cooperative. 0 = No 1 = Yes.	0.54839	0.4988
AREA	Farm size (square meter).	16371	1.18E+05
EXT	Frequency of contacts with extension. 0 = have no contact, 1 = not frequent contacts, 2 = frequent contacts.	0.75115	0.7346
EDUC	Farmers' level of education proxy 0 = no formal education. 1 = primary school, 2 = secondary school, 3 = post secondary.	1.1889	0.79131
LVSTOCK	Indexes if the farmer keeps livestock: 0 = No 1 = Yes.	0.51152	0.50102
FMSIZE	Family size.	9.9032	9.9212
SEX	Gender of the farmer 0 = female, 1 = male.	0.76037	0.42785
ASSET	value of agricultural equipments (FCFA)	30344	67354
DIST	distance of field from the homestead (m)	6834.6	54661
CASHCRP	Cultivation of cash crops 0 = No 1 = Yes	0.5023	0.50115
REGION	Dummy variable for area. 0 = Yaoundé area, 1 = Bafoussam area.	0.62212	0.48598

organic and inorganic fertilizers, and integrated soil nutrient management.

DIST is the sum distance of the farmers' fields from the homestead. Due to the highly bulky nature of composts, transportation costs for use on distant fields will be very high. Farmers are thus more likely to apply them on fields closer to the homestead. Also, distant fields may lie longer in fallow and consequently have a better soil fertility index. It is hypothesized that DIST is negatively related to choice decisions on organic and inorganic fertilizers. Since farmers may not have sufficient amounts of either inorganic or organic nutrients for exclusive use on distant fields, it is more likely that farmers will pursue a strategy of mixing these inputs for distant fields. Thus, it is hypothesized that DIST is positively related to use of integrated soil nutrient management.

CASHCRP is a dummy variable, which indexes if the farmer cultivates a cash crop. Given higher returns to cash crop cultivation, farmers are likely to invest in soil nutrient management technologies for these crops. It is hypothesized that CASHCRP is positively related to farmers' choice of the three soil nutrient management technologies relative to the reference state.

REGION is a dummy variable which takes the value of 1 for farmers in Bafoussam area and 0, for Yaounde area. Very high population pressure and evident problems of soil nutrient depletion in Bafoussam have

increased the sensitivity of farmers to investment in soil nutrient management. Commercialized composts made from urban wastes are extensively used by farmers in the region. The Yaounde zone is in a forest zone, where relatively low population density does not yet pose major problems for soil fertility. It is hypothesized that the probability of adoption of organic and inorganic fertilizers, and integrated soil fertility management practices will be higher in the Bafoussam area than in Yaounde. A positive sign is hypothesized for REGION.

The descriptive statistics on the variables included in the empirical models are given in Table 1.

Results and discussion

Table 2 shows the distribution of farmers by their methods of soil nutrient management. Four categories were identified. First, 30% of the farmers did not use either organic or inorganic fertilizers. Second, 30% of the sample farmers used only inorganic fertilizers. Third, 26% relied on the use of organic soil nutrients alone. Fourth, 14% relied on integrated use of both organic and inorganic nutrients. The extent of use of soil nutrient management practices is higher in Bafoussam than Yaounde. This may be due to the very high population pressure in Bafoussam and rapid shortening of fallows

Table 2. Soil Fertility Management Categories for Sample Farmers by Region, Cameroon

	Bafoussam	Yaoundé	Total
Farmer uses neither inorganic or organic fertilizers	18 (13.3%)	47 (57.3%)	65 (30%)
Farmer uses only inorganic fertilizers.	53 (39.3%)	12 (14.6%)	65 (30%)
Farmer uses only organic fertilizers	36 (26.7%)	20 (24.4%)	56 (25.8%)
Farmer integrates the use of organic and inorganic fertilizers	28 (20.7%)	3 (3.7%)	31 (14.3%)
Total	82 (100%)	135 (100%)	217 (100%)

which have increased incentives for farmers' investment in better soil fertility management practices. In Yaounde, the existence of forest cover and sufficient amount of land for fallowing may explain the lower use of soil nutrient management technologies.

The model results are presented in Table 3. Percentages of correct prediction for each fertility management categories are given in Table 4. As a whole, ten of the twelve variables included in the model had significant effects in explaining farmers' choices on the three soil nutrient management technologies relative to the reference state. GROUP has a positive effect on the adoption of the technologies, and was significant at 1% in influencing choice decisions on organic fertilizers. Grassroots farmers' organizations are making many efforts to convince farmers to experiment in alternatives to chemical inputs. AREA was significant and negatively related to adoption of inorganic fertilizers, organic fertilizers and integrated use of organic and inorganic fertilizers, at 1%, 1%, and 10%, respectively. For inorganic fertilizers it is likely that the relatively high costs of input use given the high quantities needed to fertilize large fields lowers the likelihood of use as farm size increases. The results suggest that smaller sized farms are more likely to adopt all soil fertility improvement strategies.

Contact with extension (EXT) is positively and significantly related to farmers' adoption of organic fertilizers, at 1% level, and integrated soil nutrient management, at 5% level. No significant effect was found for decision choice on inorganic fertilizers alone. The lack of significant effect on inorganic fertilizer use suggests that inorganic fertilizers are probably no longer viewed as "new" soil fertility management technologies by farmers. However, use of organic fertilizers (manufactured composts), and integrated soil nutrient management are relatively new to many farmers.

Farmer education (EDUC) had a positive effect on the adoption of organic fertilizers and integrated soil nutrient management, at 5% and 10%, respectively. Integrated soil nutrient management requires greater management skills than those required for the application of inorganic fertilizers alone or organic fertilizers alone, since it requires combination of two inputs in correct proportions. These results suggest that increased farmer education improves likelihood of use of integrated soil nutrient management practices. The positive effect on the adoption of organic fertilizers suggests that educated farmers are better able to comprehend the benefits of biodegradable organic sources of nutrient management on their farms. EDUC has no significant effect on the adoption of inorganic fertilizers alone. These results suggest that farmer training could have a positive impact on adoption of organic fertilizers.

The possession of livestock (LVSTOCK) has a negative effect, significant at 1%, on the utilization of organic inputs for soil fertility management. Purchased composts made from urban wastes and internally manufactured composts from household wastes (includes animal refuse) are substitutes for animal manure. Farmers using animal manure are less likely to adopt composts. It seems that farmers preferred to use manure directly than making compost with.

Family size (FMSIZE) has a positive and significant effect on the adoption of all three types of soil nutrient management practices. This result strongly suggests that the higher the availability of labor for application of these soil nutrient management practices, the greater the likelihood of adoption.

Sex (SEX) has a positive but non-significant effect on adoption of inorganic fertilizers and integrated soil nutrient management. However, SEX has a significant and negative effect on the use of organic

Table 3. Multinomial Logit Model of Investment in Soil Nutrient Management Practices, Cameroon

Variables	Coefficient		
	Inorganic fertilizers	Organic fertilizers	Integrated Soil Nutrient Management
Constant	-1.7969 (-1.944)**	-.8558 (-1.914)**	-8.1109 -4.993***
EXPE	2.94E-02 (0.93)	-6.25E-03 (-0.166)	1.67E-02 (0.467)
GROUP	0.66088 (1.22)	1.6031 (2.57)***	0.732 (1.098)
AREA	-5.09E-05 (-2.637)***	-1.86E-04 (-3.188)***	-2.90E-05 (-1.663)*
EXT	0.31292 (0.76)	1.3923 (3.137)***	0.98962 (2.186)**
EDUC	-0.28422 (-0.662)	0.99565 (2.045)**	0.80214 (1.624)*
LVSTOCK	-0.51411 (-0.818)	-2.4671 (-3.286)***	-0.87241 (-1.16)
FMSIZE	0.12185 (1.953)**	0.11112 (1.64)*	0.1057 (1.644)*
SEX	0.31702 (0.424)	-1.5015 (-2.114)**	1.4414 (0.992)
ASSET	1.19E-05 (1.783)*	1.70E-05 (2.329)***	1.38E-05 (1.875)*
DIST	-5.05E-05 (-1.17)	-1.77E-04 (-1.781)*	6.82E-05 (1.817)*
CASHCRP	0.81218 (1.362)	4.12E-02 (0.061)	0.95916 (1.384)
REGION	0.45664 (0.562)	1.9449 (2.367)***	3.9432 (3.326)***

$X^2(54) = 212.107$ ***.

Percentage of correct predictions of farmers by soil nutrient management categories = 65%

Sample = 217.

Values in parentheses are corresponding t-values. *** = Significant at 0.01; ** = significant at 0.05; * = significant at 0.10.

Table 4. Percentages of prediction for each fertility management categories

Actual	Predicted				Total
	None	Organic Fertilizer	Inorganic Fertilizer	Integrated	
None	72.3%	10.8%	12.3%	4.6%	65
Organic Fertilizer	12.3%	70.8%	12.3%	4.6%	65
Inorganic Fertilizer	14.3%	5.4%	71.4%	8.9%	56
Integrated	9.7%	48.4%	12.9%	29%	31
Total	66	71	60	20	217

Percentages are given by the ratio of number predicted over actual number. For the option None for example, % of correct prediction is 72.3% (47/65). The row total should be equal to 1.

nutrients alone, suggesting that the probability of using organic nutrients alone is higher for women than men. This result contrasts with those obtained in Burkina Faso by Matlon (1994) for animal manure use between men and women, as well as Adesina (1996) finding in Cote d'Ivoire for inorganic fertilizer use by farmers. In these studies the authors found that women had lower likelihood of use of these inputs than men. In many parts of Sahelian West Africa, men have control over the use of animal manure on their fields since animal traction equipments belong to men. Compost is made mainly from household waste, the management of which is controlled by women. This explains the higher likelihood of use of composts by women.

Farm assets (ASSET) positively and significantly influence the adoption of all of the three soil nutrient management practices. Thus, the higher the capital availability within farm households the greater is the likelihood of farmers using all the three soil nutrient management practices.

Field distance (DIST) is negatively related to the use of inorganic fertilizers and organic fertilizers, but positively related to the use of integrated soil nutrient management practice. The coefficients are significant at 10% for organic nutrients and integrated soil nutrient management. This result corroborates the findings of Adesina (1996) on inorganic fertilizer use in Cote d'Ivoire, and Prudencio (1983) on animal manure use in Burkina Faso. The distant fields are less intensively cultivated and may thus have natural fertility. Moreover, such fields are also generally larger, the possibility of using only inorganic or organic manure alone is likely to be lower, since farmers may not have sufficient amounts of either inorganic or organic nutrients for exclusive use on those fields. Farmers are more likely to pursue an integrated soil nutrient management practice on such fields, combining organic and inorganic nutrients. This particular finding will need further investigation to better understand farmers' behavior on distant fields.

Cultivation of cash crops (CASHCRP) positively affects farmers' choice of the three soil nutrient management technologies, but the effect is not significant. Region (REGION) is positively related to adoption of all three soil nutrient management practices, and is significant at 1% level, respectively, for use of organic nutrients and integrated soil nutrient management. These results indicate the probability of farmers' adoption of soil nutrient management practices are higher in the more densely populated areas than in areas

with low population densities. Globally, the econometric model estimated has a good predictive power as shown in Table 4.

The estimated coefficients in the multinomial logit model were used to calculate the predicted probabilities of farmers' adoption across the three soil nutrient management technologies. In the first scenario, three factors were considered: gender, level of education, and intensity of contact with extension agents. Results (Table 5) show that the probability of adoption of organic fertilizers were higher for women than men, regardless of the level of education and contacts with extension. However, the probability of adoption of integrated soil nutrient management is higher for men than women, and increased with the level of education and contacts with extension. In the second scenario, predictions of decision probabilities across the three soil nutrient management categories were developed using three factors: zone, distance of the fields to the village or homestead, and cultivated area. Results (Table 6) show that while the probability of use of inorganic fertilizers declines with increasing distance of the fields from the homestead, the probability of use of integrated soil nutrient management increased with distance from the homestead. Second, the probability of use of the three soil nutrient management technologies declined with increasing farm size. Third, estimated probabilities of use of inorganic fertilizer is higher in Yaounde than in Bafoussam, but the probabilities of use of organic nutrients and integrated soil nutrient management technologies are higher in Bafoussam.

Conclusions

This paper determined, using a multinomial Logit model, factors that affect farmers' decision choices across different categories of soil nutrient management technologies in Cameroon. The results showed that factors affecting farmers' adoption of inorganic fertilizers, organic fertilizers and integrated soil nutrient management are not necessarily the same, and generalizations should be avoided. The results have a number of implications for strategies to promote integrated soil nutrient management among farmers in Cameroon.

First, soil fertility management technologies, especially integrated soil nutrient management systems, should be targeted more to the higher density areas. The

Table 5. Multinomial Logit Model's predicted probabilities of farmers' soil fertility management choices by gender, level of education and intensity of contact with extension

No contact with extension							
Women				Men			
	Inorganic fertilizer	organic fertilizer	Integrated soil nutrient management		Inorganic fertilizer	organic fertilizer	integrated soil nutrient management
Education				Education			
0	0,430	0,013	0,016	0	0,490	0,002	0,055
1	0,350	0,037	0,037	1	0,390	0,007	0,130
2	0,260	0,100	0,081	2	0,270	0,017	0,270
3	0,160	0,220	0,150	3	0,160	0,036	0,460
Not Frequent Contact							
Women				Men			
	Inorganic fertilizer	organic fertilizer	Integrated soil nutrient management		Inorganic fertilizer	organic fertilizer	integrated soil nutrient management
Education				Education			
0	0,480	0,042	0,034	0	0,530	0,007	0,120
1	0,370	0,120	0,077	1	0,390	0,020	0,250
2	0,230	0,260	0,140	2	0,230	0,043	0,450
3	0,110	0,450	0,200	3	0,110	0,074	0,640
Frequent Contact							
Women				Men			
	Inorganic fertilizer	organic fertilizer	Integrated soil nutrient management		Inorganic fertilizer	organic fertilizer	integrated soil nutrient management
Education				Education			
0	0,480	0,130	0,068	0	0,510	0,021	0,220
1	0,310	0,290	0,128	1	0,330	0,049	0,420
2	0,150	0,500	0,180	2	0,160	0,088	0,610
3	0,055	0,660	0,200	3	0,065	0,130	0,730

rising population pressure on arable land creates incentives for farmers' adoption of soil nutrient management technologies.

Second, integrated soil nutrient management should be targeted to smallholder farms. The very high quantities of compost that would be needed for effective use on large farms may be non-economical; labor costs for transport and application over large fields may also be very high. Small farms can also better manufacture and use composts from household wastes in order to enhance nutrient cycling in their agroecosystems.

Third, results showed that the likelihood of use of organic nutrients and inorganic nutrients is lower for

fields far from the homestead. This implies that the use of such techniques is likely to be preferred by farmers on their home gardens, or fields close by the house. High levels of soil nutrient cycling have been reported in the home gardens in Cameroon (Tchatat 1996). Such fields are generally small enough for effective use of these inputs. Also, the proximity of these fields to the homesteads lowers farmers' transport costs for collecting and applying home-produced composts from household refuse or kitchen wastes. Distant fields are generally larger, the possibility of using only inorganic or organic manure alone is likely to be lower, efforts are needed to help farmers in integrated soil nutrient management for these fields. These could

Table 6. Multinomial Logit Model's predicted probabilities of decision choices among soil nutrient management practices in Cameroon by region, distance of the fields and cultivated area

YAOUNDE REGION						
AREA (ha)						
0.5 hectare			2 hectare			
Distance of field (km)	Inorganic fertilizer	organic fertilizer	integrated soil nutrient management	Inorganic fertilizer	Organic fertilizer	integrated soil nutrient management
0	0.519	0.175	0.011	0.436	0.019	0.012
10	0.474	0.045	0.032	0.319	0.004	0.029
25	0.290	0.004	0.115	0.169	0.2E-03	0.093
50	0.063	3.8E-05	0.486	0.037	2.9E-06	0.396
AREA (ha)						
5 hectare			10 hectare			
Distance of field (km)	Inorganic fertilizer	organic fertilizer	integrated soil nutrient management	Inorganic fertilizer	Organic fertilizer	integrated soil nutrient management
0	0.149	0.1E-03	0.008	0.014	1.2E-08	0.002
10	0.095	2.8E-05	0.017	0.008	2.1E-09	0.004
25	0.045	1.5E-06	0.048	0.004	1.5E-10	0.012
50	0.011	1.5E-08	0.220	0.001	1.7E-12	0.064
BAFOUSSAM REGION						
AREA (ha)						
0.5 hectare			2 hectare			
Distance of field (km)	Inorganic fertilizer	organic fertilizer	integrated soil nutrient management	Inorganic fertilizer	Organic fertilizer	integrated soil nutrient management
0	0.284	0.424	0.189	0.345	0.068	0.318
10	0.238	0.101	0.519	0.186	0.010	0.563
25	0.065	0.004	0.847	0.046	0.001	0.827
50	0.004	1.05E-05	0.979	0.003	9.9E-07	0.970
AREA (ha)						
5 hectare			10 hectare			
Distance of field (km)	Inorganic fertilizer	organic fertilizer	integrated soil nutrient management	Inorganic fertilizer	Organic fertilizer	integrated soil nutrient management
0	0.158	0.001	0.279	0.019	7.8E-08	0.102
10	0.079	7.6E-05	0.457	0.011	1.2E-08	0.185
25	0.021	3.02E-06	0.717	0.004	6.4E-10	0.389
50	0.001	8.6E-09	0.936	0.4E-03	2.8E-12	0.779

include integrated use of organic and inorganic nutrients, improved planted fallows or other agroforestry technologies.

Fourth, farmer education was found to have significant positive effect on the probability of use of organic nutrients and integrated soil nutrient management. The farming population in Cameroon is becoming increasingly dominated by younger farmers due largely to reverse migration from urban to rural areas arising from recent economic crisis (Pokam 1997). The

majority of the migrants are young educated workers that were retrenched from public sectors as a result of public sector adjustment programs. These growing populations of educated farmers will be better able to use integrated soil nutrient management techniques. However, there is need to also continue to target these technologies to non-educated farmers. One approach is to rely on farmer-participatory learning approaches, and researchers in Cameroon can learn from experiences elsewhere. Conway (1997) cites the case of the

Manor House Agricultural Centre in Western Kenya where farmers are being trained in the use of sustainable agricultural practices. Farmers' use of composting in the area is increasing rapidly due to this approach. Extension agents can play an important role in this: results from this paper show that farmer contacts with extension agents have strong positive effects on farmers' use of organic nutrients and integrated soil nutrient management.

Finally, efforts to promote integrated soil nutrient management should consider the important role that farmers' organizations can play. Farmers' organizations are effective in creating change within local communities. Results from this paper show that farmers in farmers' organizations have a higher likelihood of using organic fertilizers. NGOs' activities on promoting organic farming in Cameroon are largely directed to farmer groups and for good reason: they create economies of scale in the diffusion of information to farmers on the benefits of nutrient cycling in rural communities.

References

- Adesina A.A. and Baidu-Forson J. 1995. Farmers' perceptions and adoption of new agricultural technology: evidence from analysis in Burkina Faso and Guinea, West Africa. *Agricultural Economics* 13: 1–9. Elsevier science publisher.
- Adesina A.A. 1992. Village-level studies and sorghum technology development in West Africa: Case study in Mali. pp.147–168. In: Moock J.L. and Rhoades R.E. (eds). *Diversity, farmer knowledge and sustainability*. Cornell University Press.
- Adesina A.A., Mbila D., Guy B., Nkamleu G.B. and Endamana D. 2000. Econometric analysis of the determinants of adoption of alley farming by farmers in the forest zone of Southwest Cameroon. *Agriculture, Ecosystems and Environment* 158: 1–11.
- Adesina A.A. 1996. Factors affecting the adoption of fertilizers by rice farmers in Cote d'Ivoire. *Nutrient Cycling in Agroecosystems* 46: 29–39.
- Ameniya T. 1981. Qualitative response models: A survey. *Journal of Economic Literature*. Vol. XIX (December): 1483–1536.
- Bationo A and Mkwunye A.U. 1991. Alleviating soil fertility constraints to increased food production in West-Africa: The experience of the Sahel. *Fert. Res.* 29: 95–115.
- Carr S.J. 1997. A green revolution frustrated: lessons from the Malawi experience. *African Crops Science Journal* 5(1): 93–98.
- Conway G. 1997. *The doubly green revolution. Food for all in the 21st century*. London: Penguin.
- Coulibaly O. 1995. Devaluation, new technologies and agricultural policies in the Sudano-Guinean zones of Mali. Unpublished Ph.D dissertation, Department of Agricultural Economics, Purdue University, West Lafayette, Indiana, USA.
- Cramer J.S. 1991. *The Logit Model for Economists*. Edward Arnold: London, New York.
- Daramola B. 1989. The study of socio-economic factors influencing fertilizer adoption decisions in Nigeria: A survey of Oyo State farmers. *Fertilizer Research*, 20: 143–151.
- Falusi A.O. 1975. Application of multivariate Probit to fertilizer use decisions: Sample survey of farmers in three states of Nigeria. *J. Rural and Econ. Dev.* 9(1): 49–66.
- FAO 1985. Changes in shifting cultivation in Africa: Seven case studies. FAO Forestry Paper 50/1. FAO, Rome, Italy.
- FAO 1991. Issues and Perspectives in Sustainable Agriculture and Rural Development -Hertogenbosch (Netherlands), Conference on Agriculture and the Environment, 15019 April 1991 (Main Document, FAO Newsletter).
- Green W. 1992. LIMDEP Version 6.0. User's Manual and Reference Guide. Econometric Software, Incorporated. NY.
- Hailu Z. 1990. The adoption of modern farm practices in African agriculture: Empirical evidence about the impacts of household characteristics and input supply systems in Northern Ghana. Nyankpala Agricultural Research Report No. 7.
- Huffman W. 1974. Decision making: the role of education. *Amer. J. Agric. Econ.* Vol. 56: 85–97.
- ICRAF 1996. International Centre for Research in Agroforestry. Annual Report, 1996.
- Kabore P.D. 1988. Analyse economique de la fertilité des sols au Burkina-Faso. Thèse de Doctorat, CIRES, Université d'Abidjan, Côte d'Ivoire.
- Kang B.T., Hauser S., Vanlauwe B., Sanginga N. and Attakrah A.N. 1995. Alley farming research on high base status soils. pp. 25–39. In: Kang B.T., Osiname A.O. and Larbi A. (eds). *Alley Farming Research and Development. Proceedings of an International Conference on Alley Farming*. International Institute of Tropical Agriculture, 14–18 September 1992, Ibadan, Nigeria.
- Kebede Y., Gunjal K. and Coffin G. 1990. "Adoption of New Technologies In Ethiopian Agriculture: The Case Of Tegulet-Bulga District, Shoa Province". *Agricultural Economics* 4: 1. Elsevier Science Publishers, Amsterdam.
- Kelly V. 1988. Factors affecting the demand for fertilizer in Senegal's peanut basin. Ph.D Thesis, Michigan State University, USA.
- Kleinman P.J.A., Pimentel D. and Bryant R.B. 1995. The ecological sustainability of slash-and-burn agriculture. *Agriculture, Ecosystems and Environment*, 52: 235–249.
- Madalla G.S. 1983. *Limited dependent and qualitative variables in econometrics*. Cambridge University Press, New York, 401 p.
- Matlon P.J. and Adesina A.A. 1997. "Agricultural growth and sustainability: prospects for semi-arid West Africa". In: Reardon T. and Vosti S. (eds). *Agricultural Sustainability, Growth, and Poverty Alleviation: Issues and Policies*. Johns Hopkins University Press, pp. 229–260.
- Matlon P.J. 1994. Indigenous land use systems and investments in soil fertility in Burkina Faso. pp. 41–69. In: Bruce J.W. and Migot-Adholla S.E. (eds). *Searching for Land Tenure Security in Africa*. Kendall/Hunt Publishing Company. Dubuque, Iowa, USA.
- Moormann F.R. and Greenland D.J. 1980. Major production systems related to soil properties in humid tropical Africa. In: *Priorities for Alleviating Soils Related Constraints to Food Production in the Tropics*. International Rice Research Institute, The Philippines.
- Nair P.K.R. 1993. *An Introduction to Agroforestry*. Kluwer Academic Publishers.
- Nkamleu G.B. and Adesina A.A. 2000. Determinants of Chemical Input use in Peri-Urban Lowland Systems: Bivariate Probit analysis in Cameroon. *Agricultural Systems* 62: 111–121.

- Nkamleu G. B. and Coulibaly O. 2000. Le choix des méthodes de lutte contre les pestes dans les plantations de cacao et de café au Cameroun. *Economie Rurale* No. 259 September–October, 2000, 75–85.
- Nkamleu G.B. 1999. Etat des lieux de l'agroforesterie au Cameroun: cas des provinces du centre, du sud-Ouest, et du Nord-Ouest. *Revue science et changements planétaire "Secheresse"* Numéro 3, Vol. 10, Octobre 1999. pp.165–170.
- Norris P.E. and Batie S.S. 1987. Virginia farmers' soil conservation decisions: an application of Tobit analysis. *Southern J. Agric Econ.* 52: 208–220.
- Nuthall P.L. 2001. Managerial ability – a review of its basis and potential improvement using psychological concepts. *Agricultural Economics* 24: 247–262.
- Ohlmer Bo, Olson K. and Berndt B. 1998. Understanding farmers' decision making processes and improving managerial assistance. *Agricultural Economics* 18: 273–290.
- Orasanu J. and Connolly T. 1993. The Reinvention of Decision Making. pp. 3–20. In: Klein G.A., Orasanu J., Calderwood R. and Zsombok C.E. (eds). *Decision making in Action: Models and Methods*. Norwood, NJ: Ablex Publishing.
- Pokam W.K.J. 1997. Les migrations dans la zone de foret humide du Cameroun. International Centre for Forestry Research. Working Document No. 2, September. Yaounde. 93 p.
- Polson R. and Spencer D.S.C. 1991. The technology adoption process in Subsistence agriculture: The case of cassava in Southwestern Nigeria. *Agricultural Systems* 36: 65–78.
- Posner J.L. and Crawford E.W. 1992. Improving fertilizer recommendations for subsistence farmers in West Africa: The use of agro-economic analysis of on-farm trials. *Fert. Res.* 32: 333–342.
- Pretty J.N. 1995. *Regenerating Agriculture*. Earthscan Publications Limited, London.
- Prudencio Y.C. 1983. A village study of soil fertility management and food crop production in Upper Volta: Technical and economic analysis. Ph.D Dissertation, University of Arizona, Tucson, USA.
- Rahm M.R. and Huffman W.E. 1984. The Adoption Of Reduced Tillage: The Role Of Human Capital And Other Variables. *Amer. J. Agr. Econ.* 66: 405–413.
- Rahm T. and Singh R.D. 1988. Farm households in rural Burkina Faso: Some evidence on allocative and direct returns to schooling, and male-female labor productivity differentials. *World Development* 16(3): 419–424.
- Siridie S. and Giraudy F. 1994. L'utilisation de la Fumure organique par les exploitations de la region CMDT, DPCG Suivi-Evaluation de Koutiala. Enquete Specifique Regionale 94, DPCG, Suivi-Evaluation, CMDT, Bamako, Mali.
- Sanchez P.A. 1976. *Properties and Management of Soils in the Tropics*. John Wiley, New York, USA.
- Sanders J.H., Shapiro B.I. and Ramaswamy S. 1996. *The Economics of Agricultural Technology in Semi-arid Sub-Saharan Africa*. Johns Hopkins University Press, Baltimore, MD.
- Shultz T.W. 1975. The value of ability to deal with disequilibria. *Journal of Economic Literature* 13: 827–846.
- Smaling E.M.A., Stoorvogel J.J. and Windmeijer P.N. 1993. Calculating soil nutrient balances in Africa at different scales. II: District scale. *Fert. Res.* 35: 237–250.
- SMSS (Soil Management Support Services) 1986. *Proceedings Symposium on Low Activity Clay (LAC) Soils*. SMSS, Washington DC.
- Tchatat M. 1996. *Le jardins de case Agroforestiers des terres humides du Cameroun: Etude de cas des zones forestières des province du Centre et du Sud*. Thèse de Doctorat d'Ecologie de L'Université Pierre et Marie Curie (Paris VI). 145 p.
- Waddington S.R., Murwira H.K., Kumwenda J.D.T., Hikwa D. and Tagwira F. 1998. Soil fertility research for maize-based farming systems in Malawi and Zimbabwe. *Proceedings of the Soil Fertility Network Results and Planning Workshop, 7–11 July 1997, at the Africa University, Mutare, Zimbabwe*.
- Williams T.O., Powell J.M. and Fernandez-Rivera S. 1993. Manure utilization, drought cycles and herd dynamics in the Sahel: Implications for cropland productivity. pp. 89–113. In: Powell J.M., Fernandez-Rivera Williams T.O. and Renard C. (eds). *Livestock and Sustainable Nutrient Cycling in Mixed Farming Systems of Sub-Saharan Africa, Vol. II: Technical Papers*. International Livestock Center for Africa, Addis Ababa, Ethiopia.

Opportunities for and constraints to adoption of improved fallows: ICRAF's experience in the humid tropics of Cameroon

Degrande A. *, Asaah E., Tchoundjeu Z., Kanmegne J., Duguma B. and Franzel S.

Corresponding author: Ann Degrande, World Agroforestry Centre, ICRAF African Humid Tropics Regional Programme, P.O. Box 16317, Yaoundé, Cameroon; Tel: (237) 221 50 84; Fax: (223) 221 50 89, E-mail: a.degrande@cgiar.org

Abstract

Food crop production in highly populated areas of the African humid tropics is increasingly faced by problems of soil fertility with declining crop yields and higher incidence of weeds reported. Between 1988 and 1998, ICRAF has developed two improved fallow technologies using a farmer participatory approach. The first technology, a rotational tree fallow with *Calliandra calothyrsus*, has been proven to increase crop yields provided farmers cut back at 0.05 m above ground level and prune the trees twice during cropping. In addition to soil fertility improvement, *Calliandra calothyrsus* fallows have many additional short-term benefits that, if properly promoted, can accelerate adoption: reducing weeds, providing fuel wood and stakes and forming excellent apiaries as the calliandra trees flower almost all year round. However, the following constraints are likely to hamper the adoption of tree fallows by certain farmer categories: (1) trees occupy the land permanently, (2) tree management is often incompatible with current cropping system, (3) soil fertility improvement is only observed after a number of years. Therefore, a shrub fallow was designed, using *Cajanus cajan* in a relay cropping system. Farmers' response to this technology was positive. Benefits reported were higher crop yields, easier clearing of cajanus fallows, and the shading out of weeds by the shrubs. Women particularly appreciated the technology for its low labour demand and because these shrubs can be planted on land with less secure tenure. However, wider dissemination of tree and shrub fallows has been slowed down by lack of a targeted extension approach and adequate seed supply strategies, which should be based on joint efforts between farmers, extensionists, the private seed sector and farmers

Key words: *Calliandra calothyrsus*, *Cajanus cajan*, participatory technology development

Introduction

Recent research has provided evidence that soil fertility is decreasing in many farmed areas of the tropics. Tropical farmers more and more recognise low and declining soil fertility as major constraints to agricultural production (Schroth and Sinclair 2003). In Cameroon, recent population growth has resulted in a reduction of the fallow length (from 10 years to 2–3 years), leading to degradation of the natural resource. This situation has been exacerbated by the sharp fall in the price of cocoa and coffee on the world market in 1985. To compensate for the lost income, farmers have

intensified food crop production, thereby opening new crop fields from the forest. According to ASB-estimates (ASB 2000), slightly over 100,000 ha of fallow were cleared annually to create food crop fields, representing approximately 3.3% of the total land area. Market access and increasing commercialisation of agriculture further accelerate this process of intensification, often causing more soil degradation. This clearly points to the need to improve current farming practices with respect to their ability to increase and sustain soil fertility and agricultural productivity (Schroth and Sinclair 2003). In 1988, the World Agroforestry Centre began research in soil fertility management in the humid

lowlands of West and Central Africa. While trying to match improved fallow technologies to the biophysical aspects of the area, efforts were also made to make them compatible with the views, experiences and economic capacities of the farmers. This paper provides an overview of 10 years of participatory research on improved fallow management by ICRAF in Cameroon. Basically, two soil fertility improvement technologies – a rotational tree fallow and a relay shrub fallow – were tested with farmers. Using a combination of experimental trials and survey methods, the adoption potential of the innovations in terms of biophysical performance, profitability, feasibility and acceptability was examined. The results were then grouped into opportunities for and constraints to the adoption of improved fallows in the humid tropics of Cameroon. Finally, recommendations for the scaling-up of the technologies were formulated.

Methodology

Study site

Evaluation of improved fallows with farmers was carried out in the forest zone of Cameroon. The climax vegetation in the study zone is dense semi-deciduous forest around Yaoundé and dense humid Congolese forest southwards (ASB 2000). The zone has a growing period of 270–365 days and rainfall is bimodal, averaging 1,500–2,000 mm per year. The mean annual temperature is between 24 °C and 27 °C. The red and red-yellow soils fall mainly into the broad FAO soil class of Orthic Ferrasols, which are suitable for cocoa, coffee and oil palm (ASB 2000). Population density varies considerably within the zone. There is a gradient from high density of 85 habitants per square km around the capital of Yaoundé to low density of 3 people per square km in the deep forest. Food cropping, especially in those areas with rising population pressure, is based on short fallows dominated by *Chromolaena odorata* where farmers face increasingly problems of declining crop yields and augmented weed infestation. Farms are generally small and fragmented with mean annual land cover in productive agricultural use ranging between 2.6 ha per household around Yaoundé and 3.6 ha per household in Ebolowa area, south Cameroon. Roughly fifty percent of this area is accounted for by complex cocoa agroforests. (ASB 2000) The livestock sector is not well developed. Cattle husbandry is practically non-existent because of the tsetse fly and small stock

Opportunities for and constraints to adoption of fallows

and poultry production is characterised by free ranging (ASB 2000).

Improved fallow management research

In 1988, ICRAF began long-term on-station experiments to evaluate the potential of planted tree and shrub fallows as an alternative to shifting cultivation. However, soon the team understood that involving farmers in the process of technology development increases the probability that the practice will be adopted. Therefore on-farm experimentation on improved fallows started almost immediately and initially focused on assessing the biophysical performance of the technologies in researcher-designed/researcher-managed trials (type 1). Later on, the research was expanded with socio-economic surveys and farmer assessment of profitability, feasibility and acceptability of the technologies, using also researcher-designed/farmer-managed (type 2) and farmer-designed/farmer-managed (type 3) trials (Degrande and Duguma 2000; Degrande 2001; Kanmegne and Degrande 2002). In 1996, researchers teamed up with non-governmental organisations and extension agents in a technology transfer project aimed at evaluating the adoption potential of improved fallows under a wider range of ecological and management conditions. In 1998, the total number of farmers testing tree fallows with ICRAF was 236 and those involved in evaluation of shrub fallows 282. At that time, ICRAF in collaboration with its partners, decided to phase down the fallow management research in favour of a participatory tree domestication programme.

Results and discussion

Rotational tree fallows

The prototype for tree fallows, also referred to as **hedgerow intercropping**, consisted of planting leguminous trees (*Calliandra calothyrsus*) at 4 m by 0.25 m. A year later, the trees are cut back at 0.50 m above ground level and the prunings are incorporated as mulch. These management options were observed to have several shortcomings, including: (1) poor tree growth, thus low biomass yield due to early cut back and frequent pruning; (2) high labour demand and low flexibility in time of tree pruning; and (3) low impact on weed control and nutrient cycling due to absence of a fallow

phase (IRA/ICRAF 1996). To address the above problems, the management of the conventional hedgerow system was modified as follows: (1) to ensure a minimum of two years' growth after planting before cutting back; (2) a fallow phase of at least one year alternating with a year of intercropping; and (3) to cut the trees at 0.05 m instead of at 0.50 m. With these modifications the system is now referred to as **rotational hedgerow intercropping**. Further investigations have shown that under the same management, trees planted at 1m x 1m (10,000 trees ha⁻¹) and at 1m x 2m (5,000 trees ha⁻¹) produced greater or similar amounts of leaf biomass per hectare than those planted in hedges (10,000 trees ha⁻¹) (Asaah et al. 2003). Moreover, these arrangements shaded out weeds more efficiently. This system now referred to as **rotational tree fallow**, increases the flexibility of farmers in planting trees for soil fertility improvement.

Constraints to adoption

Low perceived need for soil fertility improvement

Long-term on-station trials in Yaoundé (ICRAF 1996) demonstrated that rotational hedgerow intercropping has the potential to maintain high levels of maize production without degrading the soil resource base. As shown in Table 1, rotational hedgerow intercropping with 2 years of fallow resulted in consistently high and significantly greater maize yields than annual

cropping and natural fallow. Within the topsoil, important soil fertility indicators (organic C, available P, pH and exchangeable Mg, Ca, K) under the rotational hedgerow intercropping system (allowing 2 years of fallow) were significantly higher than under the annual cropping and seasonal fallow system without trees. In spite of the excellent performance on-station, on-farm evaluation of hedgerow intercropping revealed much lower biophysical performance of the technology under farmer management (Table 2). Yield improvements of maximum 40% were reported; this is hardly enough to convince farmers to adopt the technology without auxiliary benefits. This was confirmed in a survey on continued use in 2003 (Essomba 2003) showing that 40% of the farmers who continue to farm their calliandra tree fallows perceive increased yields as an important benefit, but more importantly, 47% stressed the value of other additional benefits in the adoption of tree fallows (Table 3). Likewise, low soil fertility had been identified as main problem in the area by researchers, but at present many farmers still do not perceive it as the most limiting factor. Fifty-two percent of the households involved in tree fallow testing in 1996 assessed that more than half of their fields had good fertility and only four percent thought that the fertility status of more than half of their fields was low (Degrande and Duguma 2000). In reality, in most cases there was still a possibility to leave land to natural fallow for a reasonable long period; 73% of the trial households indicated that they have enough land to meet their household needs (Degrande and Duguma 2000).

Table 1. Fallow cropping cycles and maize grain yields (t ha⁻¹), on-station Yaoundé

Treatment	1990		1991		1992		1993		1994		1995		1996	
	1	2	1	2	1	2	1	2	1	2	1	2	1	2
T1a	1.52	NF	2.98	NF	3.54	NF	2.54	NF	2.17	NF	2.33	NF	2.69	NF
T1b	1.52	NF	2.98	NF	3.54	NF	2.54	NF	NF	NF	NF	NF	3.58	NF
T2	2.13	TF	3.70	TF	4.79	TF	5.09	TF	4.55	TF	3.33	TF	3.68	TF
T3	TF	TF	TF	TF	6.28	TF	6.09	TF	TF	TF	TF	TF	6.51	TF
T4	2.72	TF	4.48	TF	TF	TF	TF	TF	5.27	TF	4.82	TF	TF	TF
SED	0.38	–	0.28	–	0.14	–	0.44	–	0.14	–	0.36	–	0.35	–

NF=natural bush fallow; TF = tree fallow of *Leucaena leucocephala* and *Gliricidia sepium* mixture; T1 Control treatment of continuous maize cropping with 1 season of maize and 1 season natural fallow each year; in 1994 plots were split to allow the comparison with a 2-year natural fallow (T1b) in addition to continuous cropping (T1a); T2 Continuous maize cropping with 1 season of maize grown between the rows of trees (regularly pruned back as hedgerows) and 1 season of tree fallow during which the hedges were allowed to grow unchecked; T3 2 years of tree fallow followed by 2 years of cropping, as in treatment 2; T4 same as treatment 3, but starting with the cropping cycle.

Source:ICRAF Annual Report 1996, p 127.

Table 2. Effect of tree fallow on maize yield in researcher-designed/researcher-managed trials

Location	Maize dry grain yield (t ha ⁻¹)	
	tree fallow	natural fallow
NKOLFEP		
Farm 1	3.63	2.38
Farm 2	4.75	3.16
Farm 3	5.26	2.88
Farm 4	2.87	2.00
Farm 5	2.23	1.71
Farm 6	3.29	2.43
ABONDO		
Farm 7	3.61	3.20
Farm 8	3.29	2.76
MEAN	3.62	2.57
SED		0.24*
CV%		15

*Significant, $p < 0.05$.

Table 3. Benefits and disadvantages of tree fallows, in order of importance, as stated during an evaluation session on the farmers' field day, June 1997

Benefits	Disadvantages
1. Enhanced fertility/improved yield	1. Labour requirement in nursery
2. Weed suppression	2. Labour requirement for tree cutting
3. Secondary products: stakes, honey production	3. Presence of roots
4. Reduced fallow period	4. Yield response only after several years
5. Save on fertilisers	

Labour requirements

The major constraint of improved tree fallows seems to be the establishment and maintenance of the tree nursery, raised by 57% of the interviewees. Farmers complain about the time required to fill the bags and the daily watering. Unlike direct seeding, the use of potted seedlings ensures successful establishment of calliandra fallows in the humid tropics of Cameroon. Calliandra seedlings requiring approximately 3 months in the nursery, research recommended the establishment of calliandra nurseries in January to be able to transplant in April at the start of the cropping season. There is, nonetheless, some flexibility in tree establishment given the duration of the rainy season in the area, which extends to mid-November. Therefore, some farmers suggested postponing the nursing of calliandra

to the rainy season in order to avoid watering in the dry season, which seems to be a reasonable solution as watering constitutes more than 50% of the labour cost. Another constraint to tree fallows is labour demand for tree pruning, reported by 57% of the farmers. We noticed that the first pruning after planting was carried out in 80% of the tree plots, though sometimes too late, but that the second pruning is neglected in 67% of the cases. Farmers are very busy with weeding at that time and many think that the resprouts do not harm the crops anymore. However, failure to follow the recommended pruning regime is known to result in severe yield loss due to competition of the trees for light and nutrients (Kang et al. 1999). In the survey on continued use, 17% of the farmers cited 'too labour demanding' as the reason for non-expansion and 8% as reason for abandoning. Those farmers who continue to use the tree fallows indicated 'competition and shade' (17%) as an important problem, followed by 'timing of pruning' (5%) and 'too labour demanding' (2.4%). Half of the respondents mentioned that calliandra trees are very difficult to cut.

Other perceived needs

Other underlying hypotheses for the adoption of tree fallows are that the trees could provide fodder for livestock and that tree hedges planted along contour lines would be an effective means of controlling erosion. In the study zone, livestock husbandry is a secondary activity for most households; goats, sheep and pigs are free roaming during the dry season and tethered during the rainy season. Generally here farmers did not show interest in supplying fodder to their animals (Degrande and Duguma 2000). Theoretically, the adoption of hedgerow intercropping is expected to be higher on sloping land. In most villages of the study area however, farmers did not consider erosion as a major problem. Degrande and Duguma (2000) reported that 75% of the trial farmers indicated that they have less than one-quarter of their fields on steep slopes and only 4% reported that more than three-quarters of their fields are on steep slopes (steep as defined by each farmer). In evaluating the technology farmers did not mention erosion control as a benefit (Essomba 2003). The incentive to adopt hedgerow intercropping for the purpose of fodder supply or erosion control in the lowlands of Cameroon thus appears very low.

Table 4. Land-use constraints, farm conditions and potential agroforestry solutions in West Province, Cameroon

Constraint	Site	Solution
Poor soil fertility	Flat land: <0.5 ha	a. Improved fallow of sesbania, cajanus or tephrosia
Soil erosion	Flat land: >0.5 ha	b. Improved fallow of calliandra
Poor soil fertility + erosion	Slope	c. Rotational hedgerow
Destruction of crops by wind	Slope	d. Combination of (a) and (c) on same plot
	Flat land	e. Windbreak of calliandra planted at 8-10 x 0.25 m
Destruction of crops by wind + soil erosion	Slope	f. Rotational hedgerow + windbreak of calliandra planted at 4 m x 0.25 m (alternate rows are managed as hedges and the others as windbreaks or for pole production)
Bee migration/need for income diversification	Flat land or slope	g. Calliandra plantation, serving as a constant source of nectar
Dry season fodder shortage	Pasture land	h. Enrichment planting
	Home garden	i. Fodder bank or feed garden

Source: ICRAF Annual Report 1997, p 84.

Table 5. Effect of shrub fallow on crop yields in farmers' fields

Farm nr	Maize grain yield (groundnut grain yield) in t ha ⁻¹					
	1996		1997		1998	
	Cajanus	Natural	Cajanus	Natural	Cajanus	Natural
1	2.31	2.86	0.10 (0.55)	0.90 (0.30)	0.44	0.94
2	2.30	1.91	0.93 (1.07)	1.85 (0.47)	1.46	1.27
3	3.89	3.87	1.78 (0.98)	0.63 (0.46)	2.10	1.54
4	2.56	4.32	2.85 (0.33)	0.00 (0.13)	3.43	1.54
5	3.88	4.35	1.34 (0.70)	0.52 (0.52)	1.60	0.31
Mean	2.99	3.46	1.40 (0.73)	0.78 (0.37)	1.81	1.12
SED	0.364 ^{NS}		0.696 ^{NS} (0.087*)		0.417 ^{NS}	
CV%	17.8		100.9(25.1)		45.1	

NS not significant.

* Significant at p < 0.05.

Source: Degrande 2001.

Markets

In promoting fallow management techniques for soil fertility improvement one also needs to consider markets for agricultural commodities, since the sale of their surplus production depends on these markets (Izac 2003). For example, in the lowlands of Cameroon, farmers complained that yield increases brought about

by soil fertility improvement did not result in increased income because of lack of adequate market opportunities. Indeed, in most on-station and on-farm trials maize had been used as test crop. However, farmers in the study zone had difficulties selling maize surpluses, partly because of storage problems (insect attacks) and partly because of inadequate marketing strategies (individual selling of small quantities). Then, trial farmers were encouraged to use high-value crops in the improved fallow technology. For example, in areas with good market access farmers started using the technology to improve yields of vegetables and to produce stakes for their yams and tomatoes (ICRAF 1996).

Opportunities for adoption

Weed suppression

On-station and on-farm trials have demonstrated the potential of hedgerow intercropping to reduce weeds considerably (IRA/ICRAF 1996). Research in on-farm trials indicated that weed biomass after 2 years of tree fallow (2.07 t ha⁻¹) was significantly lower than after two years of natural fallow (11.54 t ha⁻¹). In 1996, 47% of the experimenting farmers mentioned weed suppression as the main advantage of hedgerow intercropping. This is an important fact knowing that in the area weeds are listed as number one constraint in agricultural production, far ahead of 'poor soils' (ASB 1996). A small number of experimenting farmers mentioned easiness of field operations as an additional advantage. This

implies a serious reduction in time for clearing the alleys and a softer soil that facilitates ploughing and weeding.

Calliandra for honey production

In the study zone, bee keeping is well known and honey has great potential as a cash enterprise. For example, 1 l of honey sells for 3,000–4,000 FCFA (5–7 USD) in Yaoundé market and 1 hive yields approximately 7.3 l per year (Mboufack 2004). *Calliandra* is known to be an excellent source of nectar, and it has been tested for honey production (16.9 µl of nectar per flower per night) in Southeast Asia (ICRAF 1996). In 1996, ICRAF in collaboration with two NGOs introduced bee keeping as a side activity in improved tree fallows. To this end, farmers were trained in construction of top-bar hives and in bee keeping techniques. Results of the survey on continued use of improved fallows (Essomba 2003) show that the main reason for farmers to extend calliandra fallows was the wish to increase honey production. Mboufack (2004) found that farmers in the Centre province of Cameroon generated on average 64,240 FCFA [42,240–85,860 FCFA] per year from hives in their calliandra plots.

Firewood and stakes

Many authors have stressed the importance of short-term benefits, such as firewood and staking material in facilitating adoption of improved fallows (Carter 1995; Buresh and Cooper 1999; Adesina *et al.* 2000). The fact that farmers usually do not mention fuel wood as a benefit from hedgerow intercropping suggests that firewood is still abundant in the study area. Nevertheless, 67% of the trial farmers (Degrande and Duguma 2000) said they collect firewood from the pruned hedgerows. Another auxiliary benefit of calliandra fallows is the production of stakes for yams or tomatoes. This advantage was recorded as number one by 47% of the interviewees and 80% of the trial farmers used wood from the hedges for staking in 1996 (Degrande and Duguma 2000). A few farmers even started selling calliandra wood for staking at 10 FCFA a piece.

Shrub fallows

While offering a multitude of opportunities, tree fallows have characteristics that hamper their adoption

Opportunities for and constraints to adoption of fallows

Table 6. Labour requirements, maize production and returns to land and labour of cajanus fallow compared to natural fallow over a 6-year period

	Cajanus fallow	Natural fallow
Present value of returns to land (CFA ha ⁻¹)	911,801	306,944
returns to labour (CFA day ⁻¹)	8,372	8,372
Total maize produced (t ha ⁻¹)	15.18	4.98
Total groundnut produced (t ha ⁻¹)	1.83	0.40
Total number of workdays	1435	483

Source: Degrande 2001.

by certain farmer categories. First, farmers who do not have long-term tenure rights will not establish tree fallows because the trees occupy the land permanently. Either those farmers do not have the right to plant trees there or they will not be able to reap the long-term benefits of the trees planted. Second, certain cropping systems are incompatible with tree fallow management. For example, the traditional mixed groundnut fields (*afup owondo*), mainly managed by women, are completely cleared from trees and vegetation residues are burnt. Moreover, groundnut does not tolerate shade. Finally, soil fertility improvement due to trees is only observed after a number of years. Because of this time lag between investment and benefit flows, resource poor farmers are less likely to adopt tree fallows. In response to the above constraints, a shrub fallow technology was designed.

The **technology** of shrub fallows with *Cajanus cajan* consists of a relay cropping system where shrubs are established by direct seeding (1m x 0.40m) and maize is intercropped between the rows of shrubs (1m x 0.40m). After maize harvest, shrubs are left in the field for another season. In year 2, the shrubs are slashed, the residue is burnt and crops are planted. In year 3, the cycle recommences with shrub establishment, intercropped with maize.

Opportunities for adoption of shrub fallows

In on-farm trials, *Cajanus cajan* is reported to produce up to 8.5 t ha⁻¹ of total dry biomass (IRAD/ICRAF 1997). Table 5 shows **crop yield** data for 5 type-1

trials over a 3 years period. Following conclusions can be drawn from these results. (1) Intercropping of cajanus with maize during establishment does not decrease crop yields. At establishment, the difference in maize grain yield in cajanus fallows (2.99 t ha^{-1}) was not significantly different ($\text{SED} = 0.364$) from the one without cajanus (3.46 t ha^{-1}). (2) Crop yields after cajanus fallow are higher than after natural fallow. An average yield increase of 80% for maize and 97% for groundnut was observed. (3) A residual effect of cajanus on yields is observed in the third year. Maize yield in cajanus plots (1.81 t ha^{-1}) is 60% higher than in natural fallows (1.12 t ha^{-1}). Although statistically not significant, farmers perceived this increase in crop yields.

Half of the 28 farmers interviewed mentioned increased yields as a reason for expanding cajanus fallows and 35% reported it as main **benefit** of shrub fallows. In fact, 92% of the farmers who tried the technology noted a positive impact of cajanus fallow on crop yields, while only two farmers had not seen a change in yield. Farmers' second most important reason for expansion was soil fertility improvement, mentioned by 39% of the farmers. The third main benefit, considered by 32% of the respondents was the potential of cajanus to suppress weeds during the fallow period. The potential use of the cajanus grains as food was reported by 30% of the farmers interviewed, while 18% noted as benefit the shortening of the fallow period and the ease of clearing and ploughing following the fallow.

There is a clear **interest of women** in cajanus fallows because of the following: (1) Clearing of a cajanus fallow is much easier compared to the natural fallow. (2) After clearing the cajanus and spot burning of the woody residues, the field is clean and can easily be ploughed for groundnut planting. Groundnut is the main crop in the mixed food crop fields and is generally managed by women. (3) Cajanus is established through direct seeding, a less labour intensive technique than nursing and transplanting tree seedlings. Given the high demand for women labour, incentives exist to adopt low labour-intensive technologies. (4) Yield response to shrub fallows is relatively quick compared to tree fallows, an incentive for poor households with very high discount rates.

Economic analysis of cajanus fallows compared to natural fallows projected over 6 years demonstrates the **profitability** of the technology in the humid lowlands of Cameroon (Degrande 2001). Results of the economic analysis are summarised in Table 6. The shrub fallow increases total maize production per hectare over

the six-year period by 200% and groundnut by 350% relative to natural fallow. Relay cropping the shrubs into maize greatly reduces the extra establishment and weeding requirements of the shrubs. In fact, during the establishment phase, land preparation, weeding and even planting labour demand does not change from the cajanus to the natural fallow plot. Total labour requirement in cajanus fallows is 3 times higher than that in natural fallows, because shrub fallow plots are cropped every year. Aside from labour, extra costs of cajanus fallows are only for shrub seeds. Net present values per hectare for shrub fallows are 3 times higher than for natural fallows. Comparing returns to labour, improved fallows outperform natural fallows, but only by 17%. In summary, cajanus fallows can be a profitable alternative to natural fallows for households that do not have enough land to practise the long natural fallows, required to restore soil fertility.

Constraints to adoption

Thirty-five percent of the farmers interviewed in 1998 did not experience any **problems** in using cajanus fallow. Storing cajanus seeds was cited as a problem by 23% of the trial farmers at that time. In a survey on continued use of cajanus fallows carried out in 2003 however, 65% of the respondents cited lack of seeds and problems with storing seeds as main obstacle to the practice of cajanus fallows.

Diverse problems, diverse solutions

Unlike successes with technology transfer in commodity-specific research and development, early attempts to transfer tree and shrub fallows to farmers by several organisations fell short of achieving the desired objective, as farmers were simply asked to experiment with the technology, whether or not it was relevant to their circumstances (ICRAF 1997). In 1996, a fresh start was taken when ICRAF teamed up with NGOs and extension agents to evaluate the adoption of several improved agroforestry techniques not only in the tropical forest zone but also in the humid western highlands of Cameroon. Farmers were now provided with a broader set of agroforestry options, including the use of contour hedgerows for erosion control and as windbreaks, improved tree and shrub fallows for soil fertility management, apiculture and fuel wood production, fodder banks for small stock management;

and enrichment planting of pasture land for livestock production. The approach used (ICRAF 1997) consisted of village meetings, during which farmers were asked to list all the constraints they face that were then ranked in order of priority. This diagnostic phase was followed by the selection of those constraints that can be addressed through improved agroforestry techniques and the matching of possible technology against each constraint (Table 4). The researcher then gave the farmers a detailed description of each technique, its management requirements and costs, the conditions under which it is likely to work best, and expectations as to the results. Possible disadvantages as well as disadvantages of the technology were presented. This experience showed that farmers differ significantly in what they see as major constraints in their village. Individual farmers, assumed to be faced with similar constraints, differ markedly in their choice of technologies to test. Their choices reflect their different resource endowments and production objectives. By working closely with farmers during the technology development process, effective 'selling points' for the new technologies can be identified for different groups of farmers, as suggested by Franzel *et al.* (2002).

Conclusion and recommendations

Between 1988 and 1998 ICRAF together with partners has developed two improved fallow technologies – a rotational tree fallow with *Calliandra calothyrsus* and a shrub fallow with *Cajanus cajan* – using a farmer participatory approach. The objectives of this paper were to present incentives and constraints to the adoption of these technologies in the light of facilitating wide-scale promotion of soil fertility management options in the humid forest zone of Cameroon. Evidence from 10 years of research by ICRAF shows that tree and shrub fallows have potential to be adopted by farmers of the area provided that the benefits of the options are matched with farmers' needs and capabilities. Participatory research has found out that the initial objectives for which the calliandra tree fallow was designed, i.e. soil fertility decline and soil erosion, were not major production constraints from a farmer point of view. However, calliandra tree fallows have many auxiliary benefits that can make them more attractive. As farmers are constantly in search of income diversification for example, calliandra offers opportunities for beekeeping and production of staking material. *Cajanus* fallows in turn have proven to be less

labour demanding, to yield benefits more quickly and the production of edible grains is particularly attractive to women. On the other hand, in the forest zone of Cameroon, one can easily identify areas where incentives for soil fertility management exist or are likely to occur in the near future; i.e. areas close to urban centres with increasing land-use pressure, which triggers land-use intensification, often resulting in soil fertility decline. There are also villages that have soil erosion problems and where fuel wood becomes scarce. Here, extension should focus on the establishment of demonstration plots that clearly display the benefits and requirements of soil improvement technologies to farmers.

Farmer evaluation of improved fallows has revealed that tree and shrub establishment continues to be a major constraint to adoption. This is for example the case of high labour costs for nursing calliandra seedlings and low availability of *cajanus* seeds. Therefore, continued efforts from research and development organisations are needed to lower costs of tree establishment and to develop adequate strategies for improved fallow seed production and dissemination, preferably at community-level.

References

- Adesina A.A., Mbila D., Nkamleu G.B. and Endamana D. 2000. Econometric analysis of the determinants of adoption of alley farming by farmers in the forest zone of southwest Cameroon. *Agriculture Ecosystems and Environment* 80: 255–265.
- Asaah E., Degrande A., Kanmegne J. and Duguma B. 2003. Effects of different spacing of *Calliandra calothyrsus* on soil fertility management in moderately acid soils of southern Cameroon. A poster presented at the International Conference on Local Land Use Strategies in a Globalizing World: Shaping Sustainable Social and Natural Environments. Institute of Geography, Geocenter, University of Copenhagen Denmark, August 21–23, 2003.
- ASB 2000. Summary report and synthesis of Phase II in Cameroon. Alternatives-to-Slash-and-Burn, Nairobi, Kenya. pp. 2–7.
- ASB 1996. Preliminary results of the Alternatives-to-Slash-and-Burn Characterisation Survey in the intensification blocks of Yaoundé, Mbalmayo and Ebolowa. IITA-HFS. Yaoundé, Cameroon.
- Carter J. 1995. Socioeconomic factors influencing alley farming adoptability. *Natural Resource perspectives*, Supplement A to No. 3. ODI, UK.
- Buresh R.J. and Cooper P.J.M. 1999. The science and practice of short-term improved fallows: symposium synthesis and recommendations. *Agroforestry Systems* 47: 345–356.
- Degrande A. 2001. Farmer assessment and economic evaluation of shrub fallows in the humid lowlands of Cameroon. *Agroforestry Systems* 53: 11–19.

- Degrande A. and Duguma B. 2000. Adoption potential of rotational hedgerow intercropping in the humid lowlands of Cameroon. *Agricultural Research and Extension Network Paper* No. 103. ODI, London, UK. July 2000.
- Essomba H.B. 2003. Adoption des jachères améliorées arborées et arbustives: cas des villages pilotes de l'ICRAF dans les départements de la Lékié et de la Mefou et Afamba. Rapport de stage de pré-insertion professionnelle. Université de Dschang, Faculté d'Agronomie et des Sciences Agricoles. Dschang, Cameroun. 33 p.
- Franzel S., Scherr S.J., Coe R., Cooper P.J.M. and Place F. 2002. Methods for assessing agroforestry potential. In: Franzel S. and Scherr S.J. (eds). *Trees on the Farm. Assessing the Adoption Potential of Agroforestry Practices in Africa*. CAB International in association with ICRAF. pp. 11–37.
- ICRAF 1997. ICRAF Annual Report. ICRAF, Nairobi, Kenya, 204 p.
- ICRAF 1996. ICRAF Annual Report. ICRAF, Nairobi, Kenya, 340 p.
- IRA/ICRAF 1996. Annual Progress Report. Yaoundé, Cameroon.
- IRAD/ICRAF 1997. Annual Progress Report. Yaoundé, Cameroon.
- Izac A. 2003. Chapter 2. Economic aspects of soil fertility management and agroforestry practices. In: Schroth G. and Sinclair F.L. (eds). *Trees, Crops and Soil Fertility. Concepts and Research Methods*. CAB International 2003. pp. 13–39.
- Kang B.T., Atta-Krah A.N. and Reynolds L. 1999. *Alley Farming*. The Tropical Agriculturalist. IITA, CTA. Macmillan Education Ltd.
- Kanmegne J. and Degrande A. 2002. From alley cropping to rotational fallow: Farmers' involvement in the development of fallow management techniques in the humid forest zone of Cameroon. *Agroforestry Systems* 54(2): 115–120.
- Mboufack C.B. 2004. Importance sylvo-apicole de *Calliandra calothyrsus* (Meissner) et caractérisation de l'apiculture au Cameroun: cas des départements de Boyo (province du nord-ouest), de la Lekie et de la Mefou-Afamba (province du centre). Mémoire présenté en vue de l'obtention du diplôme d'Ingénieur des Eaux, Forêts et de Chasse. Université de Dschang, Faculté d'Agronomie et des Sciences Agricoles. Dschang, Cameroun. 70 p.
- Schroth G. and Sinclair F.L. 2003. Chapter 1: Impacts of trees on the fertility of agricultural soils. In: Schroth G. and Sinclair F.L. (eds). *Trees, Crops and Soil Fertility. Concepts and Research Methods*. CAB International 2003. pp. 1–13.

The Effect of Socio-Economic Factors on a Farmer's Decision to Adopt Farm Soil Conservation Measures. An Application of Multivariate Logistic Analysis in Butere/Mumias District, Kenya

Victoria E. Anjichi¹, L.W. Mauyo², and M.J. Kipsat³

¹*Department of Horticulture, Moi University, Box 1125, Eldoret, Kenya, Tel: +254 720 536400,*

Fax: +254 532063257, Email: vashiali@yahoo.com; ²*Ministry of Agriculture, P.O. Box 4500, Eldoret, Kenya;*

³*Department of Agric Resource Economics, Moi University, Box 1125, Eldoret, Kenya*

Abstract

This study was conducted to identify the various socio-economic variables and how they affect the farmer's decision to adopt soil resource conservation measures in Butere Mumias District. Soil is a fixed national asset which is essential to guarantee food security, cash crop and industrial crop production. It is important to conserve this resource since it cannot be expanded. The study considers the policy framework that needs to be put in place to stimulate the adoption of soil conservation measures. The study area was divided into five clusters and using households as sampling units, forty households were selected per cluster using the simple random sampling technique. A total of 200 respondents were interviewed using structured questionnaires. A Logit model was employed to identify the main factors influencing adoption of soil conservation measures on farms surveyed in this district. The SAS computer package was used to run the model, to derive the maximum likelihood estimates of the adoption process and to calculate the chi-square. The results of the Logit analysis showed that education, age, gender, and land size were significant at 0.05 level of significance. This is an indication that these are critical factors influencing adoption of soil resource conservation measures in the district. Formal education is vital and farmers should be educated on the need to adopt soil conservation measures on their farms. Attention should be focused on the farmers who are over 50 years old who are the main decision makers in most households. The role of extension in promoting individual and corporate soil conservation measures should not be down played especially as concerns providing technical advise. Small-scale farmers should be encouraged to intensify soil conservation as this will improve their soil fertility and improve their yields making their farming profitable

Key words: soil resource conservation, socio-economic factors, soil fertility degradation

Introduction

Kenya heavily depends on agriculture as the mainstay of her economy. Land is a fixed national asset that is used every year for food production, cash crop production and industrial crop production. It is essential that soil fertility degradation to be checked by all stakeholders to ensure sustainable use by future generations. At the national level, land resource management and conservation has been a priority as the government has

sponsored many soil and water conservation programs. It is important to empower farmers to combat soil fertility degradation as a routine. Stepping up soil conservation measures is a major way of combating soil fertility degradation. In the past, efforts to conserve soil have been carried out by the central government projects where personnel were hired to construct various soil conservation measures including construction of terraces, run-off water stop checks, water diversion ditches etc. These have worked well for as long as the project

is in progress. Many of these soil conservation activities have ceased as soon as such projects come to an end. Soil fertility degradation issues in Butere/Mumias District are very important because people in this district solely depend on farming for their livelihood. The population growth rate in this district stands at 3.5% per annum resulting in a rapid decline of family land size. This indicates serious need to have soil conservation measures in place to ensure sustainable crop production.

This paper presents results of an on-farm survey conducted in 2001 in the six divisions of Butere/Mumias district. The survey focused on the socio-economic variables of age, gender, education, land size, disposable income and off-farm income and how they affect the farmer's decision to adopt and maintain soil resource conservation measures in the district. The aim of this study was to safeguard soil fertility by putting in place and maintaining the necessary soil conservation measures. The fundamental issues discussed in this paper are:

- the threshold disposable income that can ensure sustenance of soil conservation measures in Butere/Mumias district,
- the implication of age in the decision making mechanism with regard to adoption of soil conservation measures as a technique to combat soil fertility degradation,
- the influence of the farmer's gender on the farmer's decision to adopt,
- at what level is the size of the farm crucial to having these measures,
- the willingness of the farmer to set apart some of his land to construct soil conservation measures,
- and the impact of non-farm income on adoption of soil conservation measures as a soil fertility sustenance technique,
- the policy frame-work which needs to be put in place to stimulate the adoption of soil conservation technologies.

Methodology

Primary and secondary data was collected and used in the analysis. Secondary data was collected from existing and relevant data and publications. Vital information was also collected from Ministry of Agriculture, Ministry of Environment and Natural resources. The study area was divided into five clusters. Using household sampling units, 40 households were selected per

cluster using the simple random sampling technique. This was to give every household an equal likely chance of being selected and avoid any bias that may arise otherwise. Both adopters (farmers who currently have soil conservation measures in place) and non-adopters (farmers who have interacted with adopters but decided not to adopt soil conservation measures, dropped after trying or never tried it at all) were interviewed, using a structured questionnaire that had lead and open ended questions. Two analytical approaches were used, the chi-square and logit model.

Chi-square analysis

The status of the respondent levels of adoption (adopters or non-adopters) of soil conservation measures was classified in groups and with respect to each socio-economic variable; a contingency table was drawn up. The chi-square statistic was used to analyze the contingency table data. The formula given below:

$$X^2 = \sum (f_e - f_o)^2 / f_e \quad (1)$$

Where:

- . X^2 = Chi-square
- . f_e = expected frequency
- . f_o = Observed frequency

The use of chi-square helps to decide whether two variables independent or independent are related in a population. The test also determines if a conspicuous discrepancy exists between the observed and the expected counts. It was employed in the analysis to test whether the explanatory variables were related among the adopters and the non-adopters.

Logit model

For this study in Butere/Mumias, the logit model was used because it reflected the empirically observed status of on farm soil conservation measures on any particular farm. Such observations reflect a dichotomous variable, adoption. This 'adoption behavioral model' with dichotomous (or) binary dependent variables can be used as a conceptual framework to examine variables associated with the adoption of soil conservation measures. Although least square estimates can be computed binary models, the error terms are likely to be heteroscedastic leading to inefficient parameter estimates;

thus classical hypothesis tests, such as the t-ratios are inappropriate (Pindyck and Rubinfeld, 1981). The application of the conventional OLS technics in bias over estimation and inconsistency (Maddala, 1983) and it has been shown both theoretically and empirically that a logit or tobit analysis is more appropriate in such cases (Maddala, 1983, pp.149–194). The use of logit, which gives the maximum likelihood estimates, overcome most of the problems associated with linear probability models and provides estimators that are asymptotically consistent, efficient and gaussian so that the analogue of the regression t-test can be applied. The logit model based on the cumulative logistic probability function, is computationally easier to use than the probit and tobit models and was used in this study (Pindyck and Rubinfeld, 1981, p.311 and p. 287).

Conceptually, the following is the general adoption behavioural model used to examine the factors influencing the farmer’s decision to adopt farm soil conservation measures.

$$P_i = F(Z_i) \tag{2}$$

$$Z_i = \beta_0 + \sum_{j=1}^n \beta_j X_{ji} \tag{3}$$

where

P_i = The probability that an individual will adopt a given resource base (the binary variable, $P_i = 1$ for an adopter and $P_i = 0$ for a non-adopter.

Z_i = Estimated variable or index for the i^{th} observation.

F = The functional relationship between P_i and Z_i

$i = 1, 2, \dots, m$ are observations on variables for the adoption model.

They are defined in Table 1 for this analysis, m being the sample size 200

X_{ji} = The j^{th} explanatory variable for the i^{th} observation, $j = 1, 2 \dots n$

β_j Aparameter, $j = 0, 1 \dots n$

$j = 0, 1, \dots, n$ where n is the total number of explanatory variables

The logit model assumes the underlying index, Z_i is a random variable that predicts the probability of the farmer’s decision to adopt farm forestry;

$$P_i = \frac{1}{1 + e^{-z_i}} \quad \text{(The probability that an individual will adopt a given resource base)} \tag{4}$$

$$1 - P_i = \frac{1}{1 + e^{-z_i}} \quad \text{(Probability that an individual will not adopt a given resource base)} \tag{5}$$

Therefore

$$\frac{P_i}{1 - P_i} = \frac{1 + e^{z_i}}{1 + e^{-z_i}} \tag{6}$$

$$\begin{aligned} L_i &= L_n \frac{P_i}{1 - P_i} = L_n \frac{1 + e^{z_i}}{1 + e^{-z_i}} = Lne^{z_i} = Z_i \\ &= \beta_0 + \sum_{j=1}^n \beta_j X_{ji} \end{aligned} \tag{7}$$

This is the logit model Engelman, 1981 and Gujarati, 1988

Results and discussion

Model specification

For this study the stimulus index Z_i determined as a linear function of the explanatory variable summarized in the Table 1.

Model estimation

Social factors that influence the decision to adopt farm soil conservation measures in Butere/Mumias district

The age of the member of the household who manages the farm indicates their capacity to work. It also affects ones ability to adopt innovations and changes. The maximum likelihood analysis results (Table 2) showed a positive relationship between age and the decision to adopt farm soil conservation measures. This indicates that age influences the farmer’s decision to adopt. The age of the farmer affect the farmer’s knowledge and the awareness of the activities in the surrounding environment among other farmers. Analysis of the data using chi-square showed that $X^2 = 17.410$, which was statistically significant at 0.05 level of significance.

The results of the maximum likelihood analysis in table 2 showed that there was a non-significant positive relationship between sex and the decision to adopt farm soil conservation measures showing that males are not necessarily better adopters than females. Analysis using X^2 chi-square gave $X^2 = 0.028$, which was statistically non-significant at 0.05 level of significance. Sex is thus not a critical issue in a farmer’s decision to adopt farm soil conservation measures.

Table 1. Explanatory an corresponding Binary Variables for Adoption of Farm Soil Conservation Measures in Butere/Mumias District 1997/98

Explanatory Dummy	Binary Variable Value	Descriptor of Farmer
Age (X1)	0	Less than 21 Years
	1	21–55 Years
	2	Over 55 years
Sex (X2)	0	Female
	1	Male
Education (X3)	0	No Formal Education
	1	Has Formal Education
Land Size (X4)	0	0–3 acres
	1	3–10 acres
	2	over 10 acres
Disposable Income (X5)	0	Less than Ksh 60000 p.a
	1	Ksh 60000–120000 p.a
	2	More than Ksh 120000 p.a
Off Farm Income (X6)	0	No Source of Off Farm Income
	1	Has source of off farm Income

Table 2. Analysis of Maximum likelihood Estimates of Adoption

Independent Variable	Estimates	Standard Error	chi-square	Probability
Intercept	1.3450	0.8680	4.8300	0.0628
Sex	0.0687	0.3664	0.0280	0.7436
Education	0.6728	0.0166	6.0800	0.0043*
Age	1.9695	0.4102	17.4100	0.0007*

*Significant at 0.05 level of significance.

A significant difference was found between the level of literacy among adopters and non-adopters at 0.05 level of significance. The logit model indicated a positive significant relationship between adoption farm forestry and education. This accords with Oram (1988) who showed formal literate farmers would be adopters. Formal education would therefore be a critical factor in influencing the effectiveness of the farmers' participation in farm soil conservation measures. Chi-square $X^2 = 6.05$ indicating education is statistically significant at 0.05 level of significance. An educated farmer can readily access information on the value of farm soil conservation measures and how it can be effectively implemented for long term benefits to him.

Economic factors that influence the decision to adopt farm soil conservation measures in Butere/Mumias district

The logit model in table 3 showed a significant relationship between land size and the farmer's decision to

adopt farm soil conservation measures. Chi-square = 25.192. Land size is an indicator of the available economic resources and the willingness to adopt a new technology. It revolves around factors such as the risk, preference, capital constraints, labour requirement and the tenurial arrangements (Arnold, 1990). In agriculture zones, some soil conservation measures compete with cash crops with the later being preferred i.e. farmers prefer to place all the available agricultural land under some type of cash crops, in this case sugar-cane as opposed to making terraces, and leaving grass strips.

Non farm income incorporates income earned by the household from different sources other than the farm. It was apparent that non-farm income source varied greatly. This included trade, employment, casual work, credit, relatives, friends and miscellaneous sources. The logit model showed that non-farm income was non-significant at 0.05 level of significance. Chi-square $X^2 = 0.44$. Thus the off farm income earned by the household did not affect the farmers ability to adopt farm soil conservation measures. This is because its

Table 3. Analysis of Maximum Likelihood Estimates for Adoption

Independent Variable	Estimates	Standard Error	chi-square	Probability
Intercept	1.3450	0.8680	4.8300	0.0628
Land size	1.1395	0.2829	25.192	0.0004*
Non farm income	0.0125	0.4004	0.4400	0.2100
Disposable	0.0396	0.0703	0.2900	0.4110

*Significant at 0.05 level of significance.

investment is low cost since farmers often use own family labour.

Disposable income is the income that is left to the household to spend after taxation. It encompasses money accrued from different sources and used as expenditure for the household savings. Judging from the logit coefficient, the household's level of income is a pre-disposable factor. It is not critical in the decision-making framework. Statistically, the decision to adopt is not based on the income level. This is attributed to the fact that planting materials used for soil conservation work are cheap and in other instances the farmers do organize their family labour to carry out soil conservation measures a little at a time. Since majority (70%) of the households in Butere/Mumias fall in the low-income category of less than Ksh, 60000 per annum then, for farm soil conservation measures to be adopted this is the income group that needs to be targeted. This is also the threshold disposable income that can trigger the adoption of the farm soil conservation measures in the district. This is arrived at by the fact that farm soil conservation measures is a low cost investment in the long run. The low price of inputs and readily available family labour makes the low income group the target group. This low income group comprises the impoverished lot and their meager earnings cannot support other expensive technologies. They are resource poor farmers most of them having less than three acres of land thus justifying the income level of less than Ksh. 60000 per annum the household income.

Conclusions

Of the respondents interviewed, 77.5% of them were adopters and 22.5% were not. The government working hand in hand with interested Non Government Organizations should put in place a clear policy that emphasizes the need to promote farm soil conservation measures with a view of alleviating general poverty. Each of the social-economic variables studied should be addressed at levels in which it affects the farmer's

decision to adopt farm soil conservation measures. The policy implementation should be concentrated at the district level to bring it closer to the people. Promotion of farm soil conservation measures will help to reduce the low yields of farm produce which is a result of soil fertility degradation. Formal education is vital in promoting farm soil conservation measures in the area through educating farmers on its importance and the long term effects of soil fertility degradation. Attention should be focused on farmers over 50 years who are mainly decision-makers in most households and conservatives in technology adoption. Small-scale farmers should be encouraged to adopt farm soil conservation measures to increase their net production per area of land so as to increase their of income from farming.

Acknowledgement

We would like to express our deep appreciation and acknowledgement to the District Agriculture Officer Butere/Mumias District, and the entire staff for their assistance in gathering this data and availing their vehicles for our use.

References

- Arnold, J.E. (1991). Tree components in farming systems. 41:35. FAO Paper. International Journal of Forestry and Forestry Industries. IUCN. Unasylva. Gland Switzerland.
- Engelman, L. (1981). PLR: Stepwise Logistic Regression. BMDP Statistical Software 1981.Ed. Dixon, WJ), Berkeley: University of California Press, pp 330-346.
- Gujarati, D.N. (1988). Basic econometrics. McGraw-Hill Book Co. Singapore (2nd Edition).
- Jaetzold R.J. and H. Schmidt (1975). Ministry of Agriculture. Farm Management Handbook of Kenya . Vol.11 West Kenya.
- Maddala, G.S. (1983). Limited-Dependent and Qualitative Variables in Econometrics, Cambridge University Press, New York.
- Oram, P.A. (1988). Moving towards sustainability: Building the Agro-ecological Framework: In Environment (30) (9).
- Pindyck R.S. and D.L. Rubinfeld (1981). Econometric Models and Economic Forecasts. 2nd Edition: London: McGraw Hill.

Farmer's perception of planted calliandra tree fallows for shortening fallow cycles in southern Cameroon

Christian Nolte^{*1}, Bernard Ondo Zo'o² and Jean Paul Dondjang²

¹International Institute of Tropical Agriculture, Humid Forest Ecoregional Centre, Yaoundé – Cameroon; ²University of Dschang, Dschang – Cameroon, * Author for correspondence Dr. Christian Nolte, IITA-Cameroon, c/o Lambourn, 26, Dingwall Road Croydon CR9 3EE, U.K. E-mail: <c.nolte@cgiar.org>

Abstract

Fallowing land after one cropping period of eighteen months is the traditional way of restoring soil fertility and breaking weed cycles in subsistence fields of southern Cameroon. Land remained in fallow for ten years or longer, but increasing population density caused fallows to be shortened on average to 2–3 years. This has – inter alia – amplified soil fertility and weed problems for farmers. Tree fallows, planted with *Calliandra calothyrsus*, have been recommended for southern Cameroon to combat declining soil fertility and increased weed pressure in such shortened fallow-crop cycles. We tested variants of this technology with farmers in six representative villages of a forest margins benchmark area. One and a half years after tree establishment and prior to cropping, farmers were asked to give an appreciation of the fallow vegetation as well as anticipated management requirements for cropping. Sixty farmers ranked soil fertility and weed problems as one of their major concerns. Trees are widely known to be important for the restoration of soil fertility, but *Chromolaena odorata* was the most often mentioned species, thought to be important for soil fertility restoration in short fallows. When farmers evaluated the planted calliandra fallows, they appreciated the fallows' capacity to suppress weeds and thought that soil fertility would be sufficiently restored. Overall, they liked best equidistant and alley planting of trees. Crop yield after fallow was most important when farmers were asked to express their opinion about important characteristics of planted tree fallows

Key words: acid soils, agroforestry, humid zone, West and Central Africa, fallow management, short fallows, participatory technology development, farmer survey

Introduction

Fallowing land after one cropping period of eighteen months is the traditional way of restoring soil fertility and breaking weed cycles in subsistence fields of Cameroon's southern Center province. Traditionally, land remained in fallow for 10 years or longer. This system is still operated in large parts of the Center and South Provinces of Cameroon, notably in remote areas with very low population densities of 3–4 inhabitants km⁻². However, in areas with increased population density (150 inhabitants km⁻²), i.e., close to major urban centres, such as Yaoundé, or by farmers, who

have limited access to land, fallow cycles have been shortened to as low as 1–2 years, but on average to 2–3 years (Gockowski et al. 2000). This has – inter alia – increased soil fertility and weed problems as often reported by farmers in rapid appraisals.

Agricultural research in southern Cameroon has tested several interventions to combat a decline in soil fertility and increasing weed problems (Nolte et al., 1997). A USAID-funded project, that run from 1980 to 1994 (NCRE, 1994) and had developed a farming systems approach to research, had tested fertilizer application and agroforestry interventions on several major crops, grown in the region. The World Agroforestry

Center (ICRAF) run a ten-year research program on the identification of tree and woody shrub species for fallow and soil fertility improvement. A leguminous – *Calliandra calothyrsus* (Meissner) (calliandra) – and a non-leguminous – *Senna siamea* – tree were found to be the species best adapted for fallow and soil fertility improvement on the widely occurring acid soils (Duguma and Tonye, 1994). In addition, the woody shrub *Cajanus cajan* was found to be appropriate and widely tested on farm (Degrande, 2001).

When IITA started research in its new Humid Forest Ecoregional Center in Yaoundé and Mbalmayo as of 1993, planted fallow interventions were again considered as appropriate for testing with farmers (IITA, 1998). From 1995 through 1996, IITA developed with its national partners EPHTA, the Eco-regional Program for the sub-humid and Humid Tropics of West and Central Africa, and it was agreed to select and use benchmark areas for participatory on-farm research (IITA, 2000). In Cameroon, the forest margins benchmark (FMB) area was set up within the Alternative-to-Slash-and-Burn (ASB) project (Douthwaite et al., 2003). Several village and household surveys were conducted (Gockowski and Baker, 1996) that led to the selection of six principal research villages (see Figure 1), thought to represent farming practices in the region.

It is within this spiel that in 1996 we decided to set up an experiment on planted tree fallows using calliandra as test species (Nolte et al., 1998). This was based on several targeted participatory rural appraisals, conducted in these villages, in which farmers expressed concerns about soil fertility (*pauvreté du sol*) and weed problems. The trial design and objectives were intensely discussed with the farming community and the trial fields were planted with some participation of farmers. After establishment, the fields were frequently visited with farmers. Towards the end of a two-year fallow period, the visits were done more formerly, i.e., farmers' opinions were recorded and analysed. In 1999/2000, the fields were cropped with the subsistence mixed-food crop field, locally called *afub owondo*, with groundnut-cassava-maize as main crops (Nolte et al. in press).

The perceptions of farmers in West and Central Africa towards technological interventions have been investigated several times. However, African farmers' true perceptions are notoriously difficult to reveal, because farmers are usually too polite and too cautious to say what they really think in the presence of people, who are not from their community, and particu-

larly, of expatriates. Although a Cameroonian graduate student, mastering the local language, conducted this investigation, we anticipated biases towards positive responses. Walker et al (1995) recommend a systems approach to avoid many of these problems. They foster the use of open-ended interviews, which are recorded, with subsequent analysis using artificial intelligence techniques.

Adesina and Baidu Forson (1995) concluded that farmers' perceptions of technology characteristics significantly affect their adoption decisions. Enyong et al (1999) reported that in the semi-arid zone of West African farmers' attitudes to and rationales behind adoption decisions are influenced by the use of policies of land and labor resources, food security concerns, perceived profitability, contribution to sustainability and access to information. Adegbiidi et al (1999) concluded that farmers in Benin Republic are aware of the impact of their farming practices, particularly in areas of high pressure on the land. Mulder (2000a), working in the same region, mentioned that benefits to farmers are the key question of soil fertility regimes to be addressed. These benefits fall, according to the author, into the three categories of (i) an extended cropping period, (ii) an increased yield, and (iii) a wiser crop choice. However, Mulder (2000b) found that researchers' soil fertility evaluation did not match with farmers' own estimates of soil fertility. She concluded: "farmers' estimates seem to be based on very different aspects of soil fertility other than nutrient content".

Besides farmers' reluctance to say what they really think when interviewed, the researchers' perceptions are likely to influence the outcome of such surveys as well. The way questions are posed, e.g., leading questions, is but one problem. The type of questions selected is also determined by what the researcher perceives to be interesting or the problem. For example, witchcraft, although sometimes extremely important, is one element that is notoriously missing.

This paper reports on the outcome of a farmer survey, which had as one of the objectives to investigate farmers' perceptions of a fallow planted to calliandra vis-à-vis a natural fallow dominated by *Chromolaena odorata* (L.) R.M.King & H. Robinson (*chromolaena*) towards the end of the fallow period, i.e., prior to cropping. Further objectives were to gather information on general knowledge and attitudes towards soil fertility management interventions as well as farmers' opinion about the conduct of the trial and research interventions in their village at large.

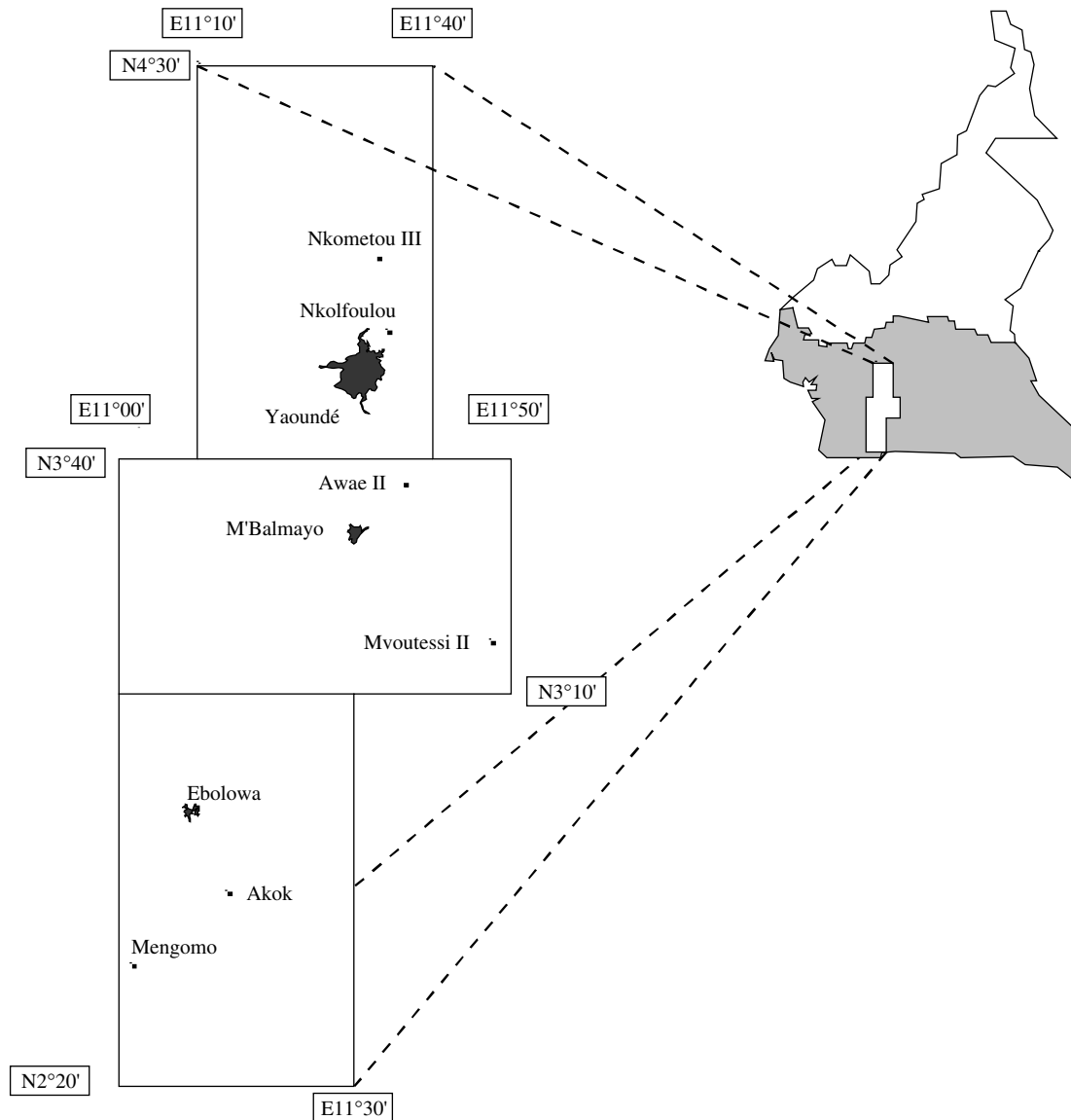

Figure 1. The forest margins benchmark area (1.54 million ha) in Cameroon's humid forest zone (21.7 million ha) and location of the six research villages.

Materials and Methods

Trial set-up

Thirty farmer fields were planted with callian-dra trees between June and October 1996 in six villages in south-central Cameroon: Nkometou (Nmet) – E11°32'14" N4°5'58" and Nkolfoulou (Nfou) – E11°35'24" N3°55'21" around Yaoundé, Awae – E11°36'40" N3°35'18" and Mvoutessi (Mvou)

– E11°47'45" N3°16'30" near Mbalmayo, and Akok – E11°14'10", N2°44'30" and Mengomo (Meng) – E11°2'19", N2°35'16" south of Ebolowa. Rainfall in the study area varies from 1650 mm at Yaoundé and 1530 mm at Mbalmayo, to 1830 mm at Ebolowa. Soils in the study area are mostly acid to strongly acid Ultisols and Oxisols and cover a wide range of soil chemical and physical properties (Nolte et al., 2003) to be found in the forest margins of West and Central Africa.

Each farmer's field served as a replicate. The fields were selected based on two criteria: (1) fallow length prior to farmers' cropping in 1996 must have been no longer than 4–6 years and (2) farmers' willingness to participate in the trial. The allocation of treatment plots within each field was done at random. Large plots were chosen so as to fit with all trial plots a normal farm size, the median size of which is 1300 m^{-2} (Gockowski et al., 1999), and to allow for realistic labour measurements. Calliandra tree seedlings were planted into plots of 19 by 24 meters according to four different planting patterns: (i) equidistant planting, with 1.6 by 1.6 meter distance; (ii) cluster planting, with 4.0 by 4.0 meter distance between the clusters and 0.4 by 0.4 meter distance between trees within one cluster of 9 trees; (iii) alley planting, with 4.0 meter row distance and 0.55 meter distance between trees within one row; and (iv) border planting, with trees planted along the plot border as a double row at 0.7 and 1.1 m from the plot border and a within row distance of 0.8 m. In each plot 180 trees were planted, equivalent to $3947 \text{ trees ha}^{-1}$ (see Nolte et al., 2003 for a detailed field plan).

These planting patterns were the outcome of discussions with farmers in each village. However, farmers suggesting treatments were not necessarily the same as participating farmers in the trial. Notably, the cluster and border-planting pattern were retained based on farmers' suggestions. The main reason for wanting cluster planting was that this arrangement approximates farmers' normal practice of leaving scattered trees on their farms after clearing a long fallow or a forest plot. The main reason given for border planting was that freely roaming small livestock, i.e., goats and sheep, often feed in fields close to the homestead, thereby destroying the crops. This forces farmers to set up their crop fields away from the homestead (generally $> 2\text{km}$), which increases mainly transport problems at crop harvest.

The calliandra tree seedlings were raised from scarified seeds in polyethylene bags for 2–3 months in nurseries, either on-station or in the respective village. Seeds were collected from farmers in the Bamenda region of northwest Cameroon and were of unspecified provenance. The trees were planted in 1996 into farmers' traditional mixed-food crop fields, which had groundnut, cassava, and maize as main crops. At the time of tree planting, the groundnut and maize had been harvested, but cassava continued to grow along with the trees for another 6–12 months. At tree planting, the fields were almost free of weeds due to the groundnut harvest. Some farmers did an additional weeding in the remaining cassava in November/December 1996.

Each field or replicate had also two control plots where no trees were planted. One plot was cropped in the same way as the calliandra tree plots at establishment of the trial in 1996 and was left to fallow after harvesting the cassava in 1997. In early 1999, therefore, this plot had two-year old natural fallow vegetation. The second control plot, had 2–3 year old natural vegetation in 1996, was not cropped and, therefore, had 4–5 year old natural fallow vegetation in early 1999.

Interview methods

In mid 1998, twenty-six fields were still in the trial, while four farmers quit due to different reasons (i.e., death of the land owner). The twenty-six farmers owning these fields were interviewed between 14 May and 25 August 1998 along with thirty-four fellow non-participating farmers (Ondo Zo'o 1998). Some characteristics of the interviewees as well as their household composition are given in Table 1.

We first conducted group interviews at each field, visiting the calliandra and the natural fallow plots. On average, five fields per village were visited. The group

Table 1. Means of farmer (all interviewed farmers – $n = 60$) characteristics and household composition in six villages of southern Cameroon

Benchmark Area region	village	farmers age (years)	farm size	Household				
				all	men <15	men >15	women <15	women >15
Yaoundé	Nkometou	45.6	2.8	6.4	1.6	1.5	1.4	1.9
	Nkoloulou	40.1	3.9	7.1	1.8	0.9	2.8	1.6
Mbalmayo	Awae	43.8	3.2	8.8	2.3	2.5	2.4	1.6
	Mvoutessi	45.6	3.5	8.3	2.8	1.6	2.0	1.9
Ebolowa	Akok	55.2	3.8	6.6	1.4	2.7	0.8	1.7
	Mengomo	45.1	3.8	6.4	1.4	2.1	1.0	1.9

interviews were followed-up by individual interviews at each farmer's home. All sixty farmers were interviewed, of which thirty-eight were male (63%) and twenty-two female (37%) farmers.

First, open-ended questions were used so as to reveal: (i) farmers' indigenous knowledge of fallow vegetation; (ii) farmers' perception of fallow techniques; (iii) farmers' general opinion about research interventions in their village. These were followed by multiple-choice questions in semi-structured interviews about the experiment at large. Answers were ranked according to: (i) labour requirement for fallow and crop management; (ii) growth characteristics of calliandra vis-à-vis the natural fallow; (iii) anticipated growth potential of calliandra after burning; (iv) likely competition between trees and crops. All questions were posed and answers were given in farmers' local language. There are slight differences in dialect across the study area. Their responses were translated first into French and, then for this paper, into English.

Data Analysis

Most data were analysed for frequency of answers pertaining to questions. Further, answers to specific evaluation questions were analysed according to the uni-dimensional scaling method of Likert (Trochim 2002). As recommended by the author, the focus of the investigation was defined first and explained to all farmers individually. Secondly, a response scale along a disagree (negative) – agree (positive) continuum was defined. However, the author's suggestions to rate items on a 1–5 or even 1–7 scale, ranging from 'strongly unfavourable to the concept' to 'strongly favourable to the concept' were modified: we used a simpler 1–3

scale, with 1 = against, 2 = indecisive, and 3 = for. Based on this coding, the means for each negative and positive answer were calculated, resulting in a mean score per answer. These means were then summed up to obtain a summary score for negative-positive evaluation.

Results

Farmers ranked soil fertility problems before crop pests/diseases, lack of mechanization, and weeds (Table 2). However, their opinion as to the research interventions in their villages overall was divided. Only about half of the farmers were satisfied with the issues addressed by IITA/IRAD's participatory research.

When farmers were asked why or why not they were satisfied with research interventions, most answered in their first reply, that the experiments do not yield relevant results (Table 3). However, this was due to the fact that farmers in three villages (Nkometou, Akok, and Mengomo) were particularly dissatisfied. They reckoned, though, that trials are encouraging and that research interventions are a good source of information or education. Many also believed that, ultimately, they would contribute to the development of their villages.

Most farmers believe that soil fertility restoration in the fallow period has to do with the occurrence of trees (Table 4). They know a large number of plant species that they relate with this knowledge. Sixteen species were listed in this survey with chromolaena at the top of that list. More than half the farmers (58%) across the six villages believe that chromolaena restores soil fertility. In all villages, except Mengomo, chromolaena was most frequently mentioned. Several natural primary succession trees, such as *Ceiba petandra*,

Table 2. Means of farmer ranking of problems (1 = most important, 4 = least important) and their satisfaction with research interventions in six villages of southern Cameroon

Problem	All	village					
		Nmet	Nfou	Awae	Mvou	Akok	Meng
Soil fertility	1.4	1.3	1.4	1.4	1.3	1.3	1.4
Crop pests/diseases	2.0	2.1	1.7	2.4	1.9	2.2	1.8
Lack of mechanization	3.2	2.9	3.7	2.9	3.2	2.8	3.5
Weeds	3.4	3.7	3.2	2.9	3.6	3.7	3.3
Answer		farmer response (number of farmers)					
No	26	6	1	3	5	7	4
Yes	27	2	6	6	6	3	4
Don't know	7	2	2	1	0	0	2

Table 3. Two reasons given by farmers why or why not they are satisfied with research interventions in six villages of southern Cameroon

Reason	village													
	All		Nmet		Nfou		Awae		Mvou		Akok		Meng	
	1	2	1	2	1	2	1	2	1	2	1	2	1	2
No reason	4	4			1	1	1	1	1	1			1	1
Does not yield results relevant for me	13	8	2	4			1	1	1	1	6	1	3	1
Is only a privilege of certain farmers	5	7	1			2	1	1	2	1		2	1	1
Failure of experiments	5	2	4		1					1				1
Bad attitude of IITA's / IRAD's agents	2	2					1		1	1		1		
Do not respect farmers' work agenda	2	6						1	1	1	1	3		1
Experiments give me a casual job	2	2	1	1					1					1
Source of information / education	8	12	1	1		4	3	1		4	1	1	3	1
Contributes to village development	6	7			3	2	1	3		1	2	1		
I am still observing	1	4	1	3										1
I have no direct collaboration experience	1	1		1									1	
Trials are encouraging	11	5			4		2	2	4			1	1	2
Total responses	60	60	10	10	9	9	10	10	11	11	10	10	10	10

Table 4. Farmers' knowledge of the importance of species for soil fertility restoration in fallows of southern Cameroon; frequency (%) of species cited, mean by species and village or of all 60 farmers

Fallow species	Local name in 'Ntumu' ¹⁾	village						
		All	Nmet	Nfou	Awae	Mvou	Akok	Meng
<i>Trees in general</i>	Ele	82	60	67	90	91	90	90
<i>Chromolaena odorata</i>	<i>Kondengui</i>	58	60	56	70	55	80	30
<i>Ceiba petandra</i>	<i>Doum</i>	35	10	0	40	36	50	70
<i>Musanga cercropioides</i>	<i>Asseng</i>	33	20	22	40	45	50	20
<i>Tryplochytton scleroxylon</i>	<i>Ayos</i>	27	0	11	40	55	10	40
<i>Aframomum spp.</i>	<i>Adiom</i>	25	0	11	10	27	50	50
<i>Costus afer</i>	<i>Mian</i>	20	0	11	10	18	40	40
<i>Ficus micoso</i>	<i>Tol</i>	17	10	22	40	9	10	10
<i>Piptadenia africana</i>	<i>Atui</i>	17	0	22	0	27	40	10
<i>Pycnanthes angolensis</i>	<i>Etang</i>	17	0	11	0	0	60	30
<i>Harungana madagascarensis</i>	<i>Atondo</i>	15	0	11	10	9	50	10
<i>Panicum maximum</i>	<i>Essong</i>	13	20	0	10	18	30	0
<i>Albizia sp.</i>	<i>Sayeme</i>	12	0	0	20	18	20	10
<i>Ricinodendron heudelotii</i>	<i>Ezezang</i>	12	0	11	20	0	30	10
<i>Tithonia diversifolia</i>	<i>Fleur marguerite</i>	12	30	0	10	0	30	0
<i>Alchornia cordifolia</i>	<i>Aboe</i>	10	0	0	10	27	10	10
<i>Mimosa pudica</i>	<i>Awousono</i>	7	0	11	10	9	10	0

Note: 1) Ntumu is a dialect of the Fang language group, spoken in the extreme south of Cameroon's South Province; following dialects are being used in the six villages: Eton (Nkometou); Ewondo (Nkolofoulou and Awae); Fong (Mvoutessi); Boulou (Akok); Ntumu (Mengomo); the first five belong to the Beti language group, the last to the Fang language group.

Musanga cercropioides, and *Tryplochytton scleroxylon*, were subsequently mentioned.

When asked about calliandra tree characteristics and management according to tree planting pattern, farmers consistently, across villages, reckoned that equidistant planting has, overall, the highest labour

requirements in terms of managing the fallow and later cropping (Table 5). This type of tree planting was perceived as posing most problems for crops, but also as having the best weed suppression potential. Burning, which is at present out of question for farmers to discuss, is perceived to affect border-planting least, but

Table 5. Mean scores of calliandra tree characteristics and management as perceived by farmers (n = 60) in six villages of southern Cameroon; scoring on a scale of 0–3, with 0 = low and 3 = high.

Tree planting pattern	All	village					
		Nmet	Nfou	Awae	Mvou	Akok	Meng
Required overall labour in put for fallow management and cropping							
Equidistant	2.4	2.9	2.4	2.1	2.5	1.8	2.8
Cluster	1.2	1.2	1.0	1.6	1.2	1.3	1.0
Alley	0.8	0.6	0.4	1.4	0.6	1.3	0.4
Border	1.2	1.2	1.0	1.6	1.2	1.3	1.0
Weed suppression potential							
Equidistant	2.5	2.2	2.4	3.0	2.4	3.0	1.8
Cluster	1.4	1.6	1.6	1.1	1.2	1.2	1.6
Alley	2.1	2.0	2.0	1.9	2.4	1.9	2.6
Border	0.1	0.3	0.0	0.1	0.0	0.0	0.0
Increased competition with crops							
Equidistant	3.0	2.8	3.0	2.9	3.0	3.0	3.0
Cluster	1.7	1.8	1.4	1.6	1.8	1.5	1.9
Alley	1.4	1.4	1.3	1.6	1.2	1.6	1.1
Border	0.0	0.0	0.2	0.0	0.0	0.0	0.0
Faster regrowth after the burn							
Equidistant	0.4	0.0	0.9	0.7	0.1	0.4	0.1
Cluster	1.4	1.6	1.5	1.4	1.5	1.5	1.0
Alley	1.7	1.7	1.5	1.5	2.0	1.6	2.0
Border	2.6	2.7	2.1	2.4	2.9	2.6	3.0
Fallow biomass growth							
Equidistant	2.5	2.2	2.4	3.0	2.4	3.0	1.8
Cluster	1.4	1.6	1.6	1.1	1.2	1.2	1.6
Alley	2.1	2.0	2.0	1.9	2.4	1.9	2.6
Border	0.1	0.3	0.0	0.1	0.0	0.0	0.0
Maintaining / increasing soil fertility							
Equidistant	2.4	2.3	2.6	3.0	2.3	2.3	1.6
Cluster	1.4	1.2	1.5	1.4	1.5	1.3	1.5
Alley	1.9	2.4	1.7	1.6	1.8	1.8	2.1
Border	0.4	0.3	0.2	0.0	0.4	0.8	0.9
Farmers' preferred planting pattern (number of farmers)							
Equidistant	22	3	4	4	4	6	1
Cluster	9	1	0	2	3	2	1
Alley	23	5	5	2	3	2	6
Border	5	0	0	2	1	0	2

planting trees around the border affects negatively fallow biomass growth, which causes low scoring for soil fertility restoration. Overall, judged by evaluating the fallow and anticipating cropping, farmers prefer alley and equidistant planting vis-à-vis cluster and border planting.

Farmers' overall evaluation of the calliandra tree fallow trial was ambiguous as depicted by the almost equal sum of positive and negative scores in Table 6. On average and in most villages, the sum of positive scores was slightly higher than the sum of negative scores. However, a statistical analysis of this difference could not

be done. The highest mean score of 3.0 was given to the opinion: "I am only satisfied, if the yields in the trial are higher than usual". This clearly indicates that agronomic performance of planted tree fallows ranks high in farmers' view. Most farmers wanted to use these fallows to grow their traditional mixed-food crop field – *afub owondo* (mean score of 2.9 to question 1), but they also expected compensation in case of lower crop yields (mean score of 2.7 to question 18). Farmers' opinion as to a flat compensation in money or kind was however indifferent; mean score of 1.8 and 2.2, respectively. Farmers' were clearly troubled by risk, as

Table 6. 'Likert' scores for positive / negative evaluation of interventions by participating farmers (n = 26) in the calliandra tree fallow trial in six villages of southern Cameroon

Question / Opinion	Type	village								
		Positive	Negative	All	Nmet	Nfou	Awae	Mvou	Akok	Meng
1. I want to establish an <i>afub owondo</i>	×			2.9	3.0	3.0	3.0	3.0	3.0	2.5
2. We have our own work material, because it is our field	×			1.8	1.5	1.7	2.2	1.8	2.0	1.7
3. Divide the field and burn only one part	×			2.4	2.0	2.7	2.6	2.2	2.2	2.5
4. Farmers & researchers should choose crops	×			2.7	2.5	3.0	2.8	2.4	3.0	2.3
5. Divide field: 1/2 cropped by farmers, 1/2 by researchers	×			2.7	2.5	2.7	2.8	2.4	2.8	2.7
6. We want a 4–5-year control plot	×			2.3	2.5	2.3	2.0	2.2	2.4	2.2
7. I am only satisfied, if the yields in the trial are higher than usual	×			3.0	3.0	3.0	3.0	3.0	3.0	2.8
8. I am satisfied also with a normal yield	×			2.3	2.0	2.3	2.4	1.8	2.6	2.5
9. No reimbursement demanded	×			2.3	1.5	3.0	2.2	2.2	3.0	1.7
10. I don't want any reimbursement	×			1.7	2.0	1.7	1.4	1.0	2.4	1.7
11. Work material has to be provided by IITA			×	2.6	3.0	2.3	2.4	3.0	2.2	2.5
12. I want a sole crop and do an <i>afub owondo</i> field elsewhere			×	1.8	2.0	2.0	2.0	1.6	1.6	1.7
13. The whole field should be burned			×	2.4	2.5	1.7	2.6	2.6	2.6	2.5
14. Researchers should choose crops to grow after fallow			×	1.7	1.5	2.0	1.2	1.6	1.8	1.8
15. Farmers should choose crops			×	1.3	2.0	1.0	1.2	1.2	1.0	1.2
16. I am afraid to crop and loose out on the trial			×	2.6	3.0	3.0	2.0	2.6	2.6	2.3
17. Increase the fallow period beyond 2 years			×	1.8	2.0	2.3	1.4	1.6	1.4	2.0
18. If the yield is < then in 1996, IITA has to reimburse			×	2.7	2.5	2.3	2.8	3.0	2.6	2.7
19. IITA has to provide money if the experiment fails			×	1.8	2.0	1.7	1.2	2.2	2.2	1.5
20. IITA has to provide in kind if the experiment fails			×	2.2	2.0	2.0	2.6	1.8	2.0	2.5
Sum positive score		10	10	24.1	22.5	25.4	24.4	22.0	26.4	22.6
negative score				20.9	22.5	20.3	19.4	21.2	20.0	20.7

Note: scores – positive: for = 3; indifferent = 2; against = 1/negative: for = 1; indifferent = 2; against = 3.

the mean score of 2.6 to question 16 (“I am afraid to crop and loose out on the trial”) shows. This, however, was to be expected since we dealt with the household's subsistence field.

Discussion

Russell (1993), an anthropologist who worked in Cameroon and DR Congo from the mid 1980's through early 1990's, listed ten top concerns of farmers: (1) wild animals devastating fields; (2) weeds; (3–4) soil fertility-*kop* – the African root and tuber scale, ravaging cassava fields in the region (Tindo et al. 2001), which seems to be aggravated on low-fertility soils;

(5) tools for clearing land; (6) other pests; (7) insufficiency of tools in general; (8) labour insufficiency; (9) cassava rot; and (10) no cash to hire labour. Based on that, weeds and soil fertility are primordial concerns of farmers in the Central African Forest zone, which is ethnically quite homogeneous. The ranking of problems in our survey (Table 2) concurs by and large with Russell's data. However, it should be pointed out that these results are in conflict with outcomes of other participatory appraisals in which farmers in Nkometou and Akok villages ranked problems differently (Mbazo'o Ondo, 2001). Here access to credit was listed as the number one problem.

Chromolaena is the dominant species of short-term natural fallows in southern Cameroon (Weise and

Tchamou, 1999). It persists up to five years in fallows of the humid zone of West and Central Africa (Slaats, 1995). “Chromolaena is the main concern of farmers, because it is the most prevalent weed and its invasion has been swift and thorough” (Russell, 1993). However, the author worked in Cameroon in rather remote areas of the Mbalmayo region, and she did not intend to analyse farming systems dynamics in the region. Our interviews revealed a rather differentiated perception of farmers. Apart from Mengomo village, that is located in an area, which still has 70% forest cover (Thenkabail, 1999), farmers perceive chromolaena’s existence in fallows rather positively in terms of its potential to restore soil fertility. Weise and Tchamou (1999) discovered a gradient in opinion that goes along with the gradient of forest cover. In areas (Ebolowa region), where long fallows still prevail and the natural succession vegetation at least in part dominates short fallows, chromolaena is disliked. However, in areas (Yaoundé region), where large forest patches have disappeared, chromolaena is preferred to many other fallow species occurring in the fallow vegetation.

The fact that planted calliandra fallows can suppress plants during the fallow which become weeds in the cropping phase (Weise and Tchamou, 1999), such as chromolaena, made farmers score calliandra fallows medium to high (2.1–2.5), provided the trees are planted in alleys or equidistantly (Table 5). These two planting patterns scored almost equally high in terms of farmers’ appreciation of their potential to maintain or increase soil fertility. Calliandra may improve soil fertility on acid soils, as was found by Gichuru and Kang (1989), Duguma et al (1994), Hairiah et al (1996), and Barrios et al (1997). However, a fallow-crop system with calliandra (alley planting) run with two fallow and three cropping cycles on station in Mbalmayo, did not yield positive effects on soil properties (S. Hauser-IITA, Cameroon, personal communication). On-farm data from West and Central Africa are scarce. Data on chemical soil properties in this experiment, where sampling was done prior to tree planting as well as at the end of the fallow period, showed inconsistent results (e.g., higher and lower values at the end of the fallow than before tree planting in the same treatment but different fields), which indicates soil-sampling problems. Yet, Koutika et al. (submitted) determined significant positive effects of callinadra fallows on soil organic matter fractions. However, it should be pointed out that according to Russell (1993) “farmers [in the Central African forest zone] will not plant trees or shrubs solely to maintain or restore soil fertility”.

Farmers anticipated the re-growth of trees after the burn to be rather low, with the exception of trees planted around field borders. Burning is standard practice with all farmers in the region. In fact, farmers are not even willing to discuss non-burning options, because it is considered rather silly to crop without having burnt the field. When asked, farmers reply that the burn not only cleans the field from debris, which is extremely important for groundnut cropping, but it lowers pressure from the first fast-growing weeds and insects. This concurs by and large with reports from farmers’ slash-and-burn practices in Indonesia (Ketterings et al., 1999).

Considering advantages and disadvantages of tree planting patterns for specific purposes together, farmers consistently, across villages, preferred, alley and equidistant planting patterns over cluster and border planting. However, it should be noted that ‘system performance’ in the cropping phase was anticipated and not experienced. As Baker (1991) pointed out: farmer-based experimentation is the required method of interaction with smallholder farmers in Africa, yet “farmer priorities are based on existing knowledge and perceived opportunity sets, . . . [but] they can not demand what they don’t know”. Another round of interviews after the cropping phase might, therefore, yield different results.

The ‘Likert’ scoring resulted in an ambiguous evaluation of research interventions by farmers with almost the same summed up score for expressed opinions or answers to questions with a positive and a negative connotation. If one assumes a normal distribution of farmers’ perceptions prior to the trial, then it has to be concluded that the trial so far did not change this much. However, answers/opinions to specific items matter. Most important is that farmers expect a superior crop yield after tree fallows vis-à-vis natural fallows for satisfaction with the technology (score 3.0 to question 7 in Table 6). Dvorak (1996) in her report about the adoption potential of alley cropping concluded: “the constraint in adoption of alley cropping is primarily agronomic”. This is of great importance. Dvorak (1996) came to this conclusion, based on socio-economic and agronomic data. Therefore, in this multidisciplinary study, agronomic performance was the most important. In many publications, other reasons are listed, such as land tenure, access to land, and labour requirements (see for example, Franzel, 1999). A thorough review of most experiments with planted tree fallows in the humid zones of West and Central Africa (Hauser et al. this issue) revealed that crop yields are only slightly improved (maize) or even negatively affected

(cassava). This concurs with crop yields in this experiment (Nolte et al. in press), which showed a tendency towards slight yield improvement for maize, no or negative yield response of cassava, and a negative yield response of groundnut. Therefore, planted tree fallows might be an option for intensive sole maize cropping, but this is not what most farmers wanted in our trial (Table 6). They wanted this technology for their subsistence mixed-food crop field, and in particular for groundnut, which is the most important crop in this field.

Conclusion

Sixty farmers in a benchmark area with Oxisols and Ultisols in southern Cameroon ranked soil fertility and weed problems as one of their major concerns. Trees are widely known to be important for the restoration of soil fertility and the majority of farmers (81.6%) attribute the dominance of a specific fallow vegetation to soil fertility. Fifty-eight percent of farmers credited soil fertility after a fallow period with the presence of *C. odorata* in the fallow vegetation, which was the highest for all species mentioned. Overall, farmers liked best equidistant and alley planting of trees. Crop yield after fallow was most important when farmers were asked to express their opinion about important characteristics of planted tree fallows. It appears, therefore, that besides socio-economic factors, such as land tenure, access to land, and labour requirements, agronomic performance of the system is an important feature in farmers' mind for planted tree fallows in the forest margins of West and Central Africa. In general, 45% of farmers expressed satisfaction with the research interventions conducted in their village so far, whereas 43.3% did not see their major problems addressed or their interests met.

Acknowledgments

The authors would like to thank farmers in Akok, Awae, Mengomo, Mvoutessi, Nkoloulou, and Nkometou villages for participating in this trial. Village contacts Adolphe Ze, Tobi Mvondo, Luc Mbom Mbom, Jean-Claude Mfomo, Rosette Mbezele, and Eloundou Atangana are thanked for their commitment to participate in the fieldwork and to organize numerous village meetings.

References

- Adegbi A., Burger K., Gandonou E. and Mulder I., 1999. Farmers' Perceptions and Sustainable Land Use in the Atacora, Benin. Working Paper No. 22, February 1999, IIED and Institute for Environmental Studies. London, UK and Amsterdam, The Netherlands, pp 57.
- Adesina A.A. and Baidu Forson J. 1995. Farmers' perceptions and adoption of new agricultural technology: evidence from analysis in Burkina Faso and Guinea, West Africa. *Agricultural Economics*, 13: 1–9.
- Baker D. 1991. Reorientation, not reversal: African farmer-based experimentation. *Journal of Farming Systems Research-Extension*, 2: 125–147.
- Barrios E., Kwesiga F., Buresh R.J. and Sprent J.I. 1997. Light fraction soil organic matter and available nitrogen following trees and maize. *Soil Science Society of America Journal*, 61: 826–831.
- Degrade A. 2001. Farmer assessment and economic evaluation of shrub fallows in the humid lowlands of Cameroon. *Agroforestry Systems*, 53: 11–19.
- Douthwaite B., Baker D., Weise S., Gockowski J., Manyong V.M. and Keatinge J.D.H. 2003. An Impact Assessment of IITA's Benchmark Area Approach. Impact Assessment Series, IITA. Ibadan, Nigeria, pp 31.
- Duguma B. and Tonye J. 1994. Screening of multipurpose tree and shrub species for agroforestry in the humid lowlands of Cameroon. *Forest Ecology and Management*, 64: 135–143.
- Duguma B., Tonye J., Kanmenge J., Tiki-Manga T. and Enoch T. 1994. Growth of ten multi-purpose tree species on acid soils in Sangmelima, Cameroon. *Agroforestry Systems*, 27: 107–119.
- Dvorak K.A., 1996. Adoption Potential of Alley Cropping. Final Project Report. RCMD Research Monograph No.23, International Institute of Tropical Agriculture. Ibadan, Nigeria, pp 70.
- Enyong L.A., Debrah S.K. and Bationo A. 1999. Farmers' perceptions and attitudes towards introduced soil-fertility enhancing technologies in western Africa. *Nutrient Cycling in Agroecosystems*.
- Franzel S. 1999. Socioeconomic factors affecting the adoption potential of improved tree fallows in Africa. *Agroforestry Systems*, 47: 305–321.
- Gichuru M.P. and Kang B.T. 1989. *Calliandra calothyrsus* (Meissn.) in an alley cropping system with sequentially cropped maize and cowpea in southwestern Nigeria. *Agroforestry Systems*, 9: 191–203.
- Gockowski J.J. and Baker D. 1996. Targeting Resource and Crop Management Research according to household endowments in the humid forest ecoregion of Central and West Africa. Paper presented at the 1996 Biennial Meeting of Rockefeller Social Science Research Fellows, Nairobi, Kenya, Aug.15 1996. Yaounde, Cameroon, IITA.
- Gockowski J., Tonye J., Baker D., Weise S.F., Tiki-Manga T., Ndoumbe M. and Fouaguegue A., 1999. Characterisation and Diagnosis of Agricultural Systems in the Alternatives to Slash and Burn Forest Margins benchmark of Southern Cameroon. ASB report Phase II, March 1999, IITA/IRAD. Yaoundé, Cameroon.
- Gockowski J., Nkamleu G.B. and Wendt J. 2000. Implications of resource-use intensification for the environment and sustainable technology systems in the central African rainforest. In: Lee D.R.

- and Barrett C.B. (eds) Tradeoffs or synergies? Agricultural intensification, economic development and the environment. CABI Publishing, Wallingford; UK pp 197–219.
- Hairiah K., Adawiyah R. and Widyaningsih J. 1996. Amelioration of aluminium toxicity with organic matter: selection of organic matter based on its total cation concentration. *Agrivita*, 19: 158–164
- Hauser S., Nolte C. and Carsky R.J. submitted. What role for planted fallows in the humid zone of West and Central Africa? Submitted to *Nutrient Cycling in Agroecosystems* (this issue).
- IITA 1998. Project 1: Short Fallow Systems to Arrest Resource Degradation Due to Land-use Intensification. Annual Report 1998, International Institute of Tropical Agriculture. Ibadan, Nigeria, pp 108.
- IITA 2000. Project 16: The Ecoregional Program for the Humid and Subhumid Tropics of Sub-Saharan Africa (EPHTA). Annual Report 1999, International Institute of Tropical Agriculture. Ibadan, Nigeria, pp 17.
- Ketterings Q.M., Tri Wibowo T., Van Noordwijk M. and Penot E. 1999. Farmers' perspectives on slash-and-burn as a land clearing method for small-scale rubber producers in Sepungur, Jambi Province, Sumatra, Indonesia. *Forest Ecology and Management*, 120: 157–169.
- Koutika L.-S., Nolte C., Yemefack M., Ndango R., Folefoc D. and Weise S. submitted. Leguminous fallows improve soil quality in south-central Cameroon as evidenced by the particulate organic matter status. Submitted to *Geoderma* in June 2004.
- Mbazo'o Ondo J.B., 2001. Rapport d'activité: Diagnostic du système de production agricole traditionnel des champs mixtes de la zone forestière du sud Cameroun: Cas de Nkometou et Akok. Mimeo, IITA, International Institute of Tropical Agriculture. Yaoundé, Cameroon, pp 15.
- Mulder I., 2000a. Farmers' Perceptions of Soil Fertility in Benin. Working Paper No. 28, February 2000, IIED and Institute for Environmental Studies. London, UK and Amsterdam, The Netherlands, pp 45.
- Mulder I., 2000b. Soil Fertility: QUEFTS and Farmers' Perceptions. Working Paper No. 30, July 2000, IIED and Institute for Environmental Studies. London, UK and Amsterdam, The Netherlands, pp 68.
- NCRE (National Cereals Research and Extension Project), 1994. Fourteen years of farming systems research. Ministry of Scientific and Technical Research (MRST), Institute of Agricultural Research (IRA), USAID, IITA. Yaounde, Cameroon, pp 180.
- Nolte C., Duguma B. and Wendt J. 1997. Recherche-développement sur la jachère améliorée en zone de forêt humide au Cameroun. In: Les actes de l'atelier de lancement du programme EPHTA dans la zone de référence pour les lisières forestières. Programme écoregional pour les tropiques humides et subhumides de l'Afrique subsaharienne - programme EPHTA. VI. Stabilisation agronomique des jachères de courte durée, IITA/IRAD Yaoundé, Cameroun, pp 24–30.
- Nolte C., Baker D., Weise S.F. and Tiki-Manga T. 1998. An experimental approach to farmer technology development for soil fertility and weed management in the forest margin of Cameroon. In: Drechsel P. and Gyiele L. (eds) *On-farm research on Sustainable Land Management in SubSaharan Africa, Experiences and Lessons*, ISRAM, Bangkok, Thailand Abengourou, Côte d'Ivoire, pp 33–44.
- Nolte C., Tiki-Manga T., Badjel-Badjel S., Gockowski J., Hauser S. and Weise S.F. 2003. Effects of calliandra planting pattern on biomass production and nutrient accumulation in planted fallows of southern Cameroon. *Forest Ecology and Management*, 179: 535–545.
- Nolte C., Tiki-Manga T., Badjel-Badjel S., Gockowski J. and Hauser S. in press. Groundnut, maize and cassava yield in mixed-food crop fields after calliandra tree fallow in southern Cameroon. *Experimental Agriculture*, 40: in press.
- Ondo Zo'o B. 1998. Développement des stratégies pour la stabilisation des jachères forestières: points de vue des paysans du benchmark. Mémoire de fin d'étude présenté en vue de l'obtention du Diplôme d'Ingénieur Agronome, Production Végétales, Dschang University. Dschang, Cameroon, pp 73.
- Russell D., 1993. Resource Management Strategies in the Central African Forest Zone: A Handbook for IITA's Humid Forest Station. Mimeograph - draft version, March 10, 1993, Humid Forest Station, IITA. Yaounde, Cameroon, pp 84.
- Slaats J.J.P. 1995. *Chromolaena odorata* fallow in food cropping systems: an agronomic assessment in south-west Ivory Coast. Doctoral thesis, Tropical Resource Management Papers, Wageningen Agricultural University. Wageningen; Netherlands, pp 177.
- Thenkabail P.S. 1999. Characterization of the Alternative-to-Slash-and-Burn benchmark research area representing the Congolese rainforests of Africa using near-real-time SPOT HRV data. *International Journal of Remote Sensing*, 20: 839–877.
- Tindo M., Hanna R., Goergen G. and Zapfack L. 2001. Non-food crop hosts of the African Root and Tuber Scale (*Stictococcus vayssierei*) in Cameroon. In: 8th symposium of ISTRC-African branch, Ibadan, 12–16 November 2001, Abstracts p.62.
- Trochim W.M. 2002. Likert Scaling. 2004. Web site, last revised 06/07/2004, downloadable at <http://www.socialresearchmethods.net/kb/scallik.htm>
- Walker D.H., Sinclair F.L. and Kendon G. 1995. A knowledge-based systems approach to agroforestry research and extension. *AI Applications*, 9: 61–72.
- Weise S.F. and Tchamou N. 1999. *Chromolaena odorata* in the humid forests of West and Central Africa: management or control. In: The 1999 Brighton crop protection conference: weeds. Proceedings of an international conference, British Crop Protection Council Brighton, U.K., pp 121–130.

Policies, Institutions and Market Development to Accelerate Technological Change in the Semiarid Zones of Sub-Saharan Africa

Mark Winslow¹, Barry Shapiro² and John Sanders³

¹ Plant Breeder and Coordinator, Oasis Program, m.winslow@cgiar.org; ² Economist, International Crops Research Institute for the Semi-Arid Tropics (ICRISAT), Patancheru, India. B.shapiro@cgiar.org; ³ Dept. of Agricultural Economics, Purdue University, Lafayette, Indiana 47907, USA, Jsander1@purdue.edu

Abstract

Agriculture in the African dry lands is constrained by geographical and economic isolation due to limited market access which affect adoption of new technology. International subsidies that flood developing-world markets with cheap food, national policies that tax the agricultural sector to benefit urban interests, and neglect of rural infrastructure discourage agricultural intensification. Increased market demand for staples and for higher-value products produced more efficiently will ensure that dryland farmers realize an economic gain from adopting more intensive practices. The interdependence of these key factors requires an integrated management of water soil fertility and improved crop varieties research focused on the poor, particularly women and children to ensure that they are equipped to capture most of the benefits of these changes. Low-value but essential food security crops need public sector assistance until their intensification becomes attractive to the private sector. Drought and market risks determine farmers' decision-making in the drylands; yet it is too often assumed that new technology increases risk. Some technologies, policies and institutions can reduce risk.

Drought risk can be combated through water harvesting, improved soil physical conditions and efficient supplementary irrigation where cost-effective. Nutrient use efficiency can be enhanced by correcting the most-limiting deficiencies, placing fertilizers directly in the root zone, combining inorganic with organic sources and adjusting topdressings to climatic conditions. Once these risks are reduced, gains from more input-responsive, longer-season varieties can be realized. Postharvest risk can be reduced and incomes increased through cooperative grain storage, inventory credit, improved processing and marketing systems, as well as diversification into new crops, crop products and related enterprises

Key words: Diversification, drought, risk, intensification, nutrient use efficiency, water harvesting, water use efficiency

Introduction

Technological change has been the main source of increased agricultural productivity throughout history (Sachs, 2002). However, markets, policies, institutions, and infrastructure have largely determined adoption of improved technologies. Most of Africa's dryland area is far from coastal ports and their urban centers. These

areas are ecologically and culturally distinctive, including the over-arching threat of drought. Most of the poor in the drylands work in agriculture, but subsidized food imports and poor input and marketing infrastructure render these areas less competitive, discouraging agricultural intensification (McCalla, 2002). There is global concern that the drylands are being left behind, becoming mired in persistent poverty and conflict.

This paper explores how productivity might be increased in dryland sub-Saharan Africa through an integrated genetic and natural resource management approach.

Are poverty and degradation inevitable in the drylands?

It has been suggested that poverty, overpopulation and land degradation create a self-reinforcing downward spiral leading to ever-greater misery (Cleaver and Schreiber, 1994). This scenario contrasts with the 'induced innovation' model of Boserup (1965), which proposes the opposite dynamic. The induced innovation model suggests that as populations grow, markets tend to develop and land becomes more costly relative to labor. These factors motivate investment in more intensive, yet sustainable land management in order to reap the benefits of the enlarged market opportunity.

Both scenarios have been observed under different situations (Pender, 1998). There are numerous pitfalls that can occur along the induced innovation pathway. Larger populations can result in more people sharing the same pie rather than a bigger pie. Farm wages are only likely to increase if crops are produced more labor-efficiently than before. This is where new technologies come into play (Hazell and Haddad, 2001; Pender, 1998). Technologies such as irrigation, fertilizer and improved varieties have been available for a long time, but their adoption has been limited due to a number of interdependent constraints.

Risk and new technology adoption

Dryland farming is inherently risky due to drought. Smallholders have only limited means for financially cushioning against risk, such as off-farm employment, family networks, and moneylenders (Anderson, 2001). Though it is often assumed that new technology increases risk, and that farmers are unwilling to take risks, these assumptions have been questioned for the Sahel (Sanders et al., 1996). Improved water management practices, the correction of certain nutrient deficiencies, and shorter-duration varieties that escape drought all reduce risk or do not increase it significantly. Smallholder farmers appear willing to take considered risks, particularly when they have had the chance to see and try a new technology

and gained confidence that it will succeed (Sanders et al., 1996; Abdoulaye and Sanders, 2005; Tiffen, 2002, 2003; Mortimore and Harris, 2004; Sanders and Shapiro, 2006).

Water availability and water use efficiency

Drought is a constant risk the drylands. Little can be done to prevent variations in rainfall. Yet more can be done to reduce drought *vulnerability* than is commonly assumed. Due to limited vegetative cover, sandy soils, and root growth limited by nutrient constraints, much of the rain that falls in the drylands either runs off or percolates below the root zone (Wood and Rydén, 1992; Breman, 1992). Breman (1992) noted that natural vegetation in the 450 mm annual rainfall zone of the Sahel utilizes only 15% of the incident precipitation and when soil physical condition and fertility are improved, water use by vegetation increased to 50% and productivity can increase fivefold.

Water harvesting and conservation technologies can reduce losses. Proven techniques developed by farmers include bunds, trenches and terraces on the slopes of the Ethiopian Highlands (Krüger et al., 1996); bunds and furrows to channel water and nutrients in Sudan (Niemeijer, 1999); *zai* holes to hold water and manure in the root zone to rehabilitate eroded hardpan soils in Burkina Faso (Kaboré and Rejj, 2004; Ouedraogo and Kaboré, 1996); and tied ridges in Mali (Sanders and Shapiro, 2003; Vitale and Sanders, 2005).

Irrigation in Africa has gotten a bad name due to the failure of large-scale projects. This has caused many to overlook the enormous potential that exists for smallholder irrigation (Kay, 2001). Even in the drylands, large numbers of farmers have access to shallow groundwater tables in river drainage basins. Smallholder irrigation is likely to be economically attractive mainly for high-value crops in reasonable proximity to urban markets. In such situations it has substantially raised farm incomes, as in the areas around Sokoto and Kano, Nigeria (World Bank, 1995) and in the Koumadougou Valley in eastern Niger (IFAD, 1999).

Though laborious or costly to implement, water conservation, harvesting and irrigation techniques deliver attractive returns on investment and substantially reduce risk (Sanders et al., 1996; Shapiro and Sanders, 1998, 2002). The fact that farmers are using them on a significant scale already is evidence of their practicality, although ways should be sought to accelerate

their spread. Often these structures can be established during the dry season when labor is readily available.

Soil fertility, fertilizer and risk

Soil nutrient deficiencies are widespread in the drylands. In much of the Sahel it is a more important constraint than low rainfall (Bationo and Buerkert, 2001; Breman, 1992). Dry and hot conditions limit vegetative growth, resulting in low soil organic matter content compared to wetter environments. Human activities exacerbate this problem. Vegetation is often removed for fuel, feed and construction purposes, instead of recycling into the soil. Soils that are low in organic matter are less effective in retaining nutrients in plant-available forms and are more susceptible to compaction and erosion. This drives organic matter and nutrient contents even lower, depressing productivity further.

Fertilizer can increase dryland productivity significantly when rainfall is adequate, but many believe that it creates unacceptable levels of risk for dryland smallholders. Recent evidence though shows that in some situations it may be risk-neutral or even risk-reducing. Phosphorus causes crops to grow hardier and mature earlier, reducing damage from and exposure to drought (Gérard et al., 2001; ICRISAT, 1985–88; Sanders et al., 1996; Shapiro and Sanders, 1998; Shapiro et al., 1993).

Once the phosphorus constraint is relieved, increased crop growth soon exhausts available supplies of nitrogen – so both P and N enhancement strategies are required. Nitrogen amendments appear to incur greater risk than phosphorous since N is not drought-protective; drought can prevent the expected yield response, leaving farmers with a loss on their N investment. Therefore, improvements in soil moisture should be implemented along with N (Shapiro and Sanders, 1998; Sanders et al., 1996). One coping technique is to split the N application between planting and tillering stages, with the second application being conditional on favorable rainfall patterns.

Some fertilizers pose risks to soil health in dryland situations. Because of low organic matter and low cation exchange capacity many Sahelian soils are weakly buffered, raising the risk of soil acidification through the use of ammonium-based fertilizers (Bationo and Buerkert, 2001). The addition of organic matter such as livestock manure remarkably moderates these effects, but these areas are not capable of producing enough manure to meet the need (Breman, 1992).

Inorganic fertilizers will be needed as complements to organic sources, but they must be introduced in ways that do not undermine soil health.

Triggering a self-reinforcing cycle of fertilizer use

Farmers have been mostly unable to implement research station fertilizer recommendations because the high rates being urged were unaffordable, risky and of questionable profitability in addition to constraints in market access, infrastructure, and liquidity. Researchers are investigating whether reducing the amount of applied fertilizer well below historical recommendation levels and placing it in the immediate root zone might help mitigate some of these problems. Phosphorus has been a focus of these studies because it is a limiting constraint in many areas of the Sahel. Government-recommended rates of 13 kg P/ha in Niger were cut to roughly one-twentieth to one-fourth of that in these experiments.

This technique is called ‘microdosing’ (Aune et al., 2004; Gérard et al., 2001). By placing the fertilizer in the planting hole, it is co-located with the main root mass early in the season, apparently resulting in a more efficient nutrient uptake. Microdosing reduces the farmer’s cash outlay while increasing the efficiency of cash use (return on investment). Low rates also reduce the soil health risk. Although the response to microdosing varies significantly across locations, across different soil types, field histories, and fertilizer formulations, it commonly increases yields by 50–100% on typical smallholder farms.

The benefit/cost ratio (value of additional grain divided by cost of fertilizer to obtain that grain) is a useful rule of thumb in assessing likely adoptability. A value above 3 is generally considered attractive enough to spur adoption. In farmer’s sorghum fields in Bafaloubé, Mali in 2002, Aune et al. (2005) applied 0.6 kg P/ha with the microdosing technique and the yield response resulted in a very attractive benefit–cost ratio of 12.4. Across 150 farmer’s field trials in Sadore, Karabedji and Gaya in Niger, Bationo (unpublished data) applied 4 kg P/ha delivering a benefit–cost ratio of 9 when fertilizer cost is double the value of the same weight of millet. Equally impressive responses have been observed on maize in dryland areas in Zimbabwe, with a 10:1 benefit/cost ratio (Dimes et al., 2006). Some though have obtained less dramatic results (Gérard et al., 2001).

It appears that microdosing can be economically rewarding in many nutrient-depleted situations. Major efforts are underway to disseminate this technology. Food Agriculture Organization (FAO) is sponsoring 'Projet Intrants' which has conducted hundreds of demonstrations across Niger. With DFID support, ICRISAT and Zimbabwe are distributing seed and ammonium nitrate with microdosing instructions (apply at one-quarter the former recommended rate per hectare) to 160,000 farm families.

Since most dryland farmers are starting from a very low yield base of around half a ton of cereal grain per hectare, there is room for even greater yield gains than those generated by microdosing. Higher fertilizer rates combined with better water supply can move yields into the 2-ton range while reducing risk (Sanders and Shapiro, 2003). Although the high benefit–cost ratios for microdosing decrease as fertilizer rates increase, higher rates are still profitable (Sanders et al., 1996).

Microdosing might trigger a process of increasing fertilizer use that becomes self-reinforcing over time. As fertilizer stimulates the growth of more crop biomass than is needed for human and livestock purposes, the excess would add to soil organic matter reserves. Higher soil organic matter would improve plant growth and fertilizer response the next season. Improved plant growth would generate larger responses from improved varieties, motivating their adoption. These increasing gains could create a self-reinforcing cycle (Bationo and Buerkert, 2001; Shapiro and Sanders, 1998). This gradual intensification could allow farmers to observe, learn and adjust their practices and resources in ways that are more sustainable for the longer term than approaches that jump in one step from subsistence to high levels of production.

Integrating improved varieties into the system

If nutrients and water are adequate, more responsive varieties can markedly elevate yields in the drylands as elsewhere (Sanders et al., 1996). These varieties have had little impact to date because those conditions have not been in place (Ahmed et al., 2000).

Under the existing low-input, subsistence scenario, crop improvement has succeeded in reducing late-season drought risk by breeding for early maturity. While this objective can contribute to food security and help capture higher early-market prices, it puts a limit on potential yield gains (Sanders and Shapiro, 2006). Varieties must also be made available that

enhance the rewards farmers receive from intensifying production.

Stabilizing and expanding markets for low-value staple crops

Productivity-enhancing interventions will only attract farmers if they are confident that they can sell their grains for a profit. The grain crops of the African drylands, millet and sorghum are not traded internationally so the local market is easily glutted, causing farm prices to crash – followed by shortages and rising prices a few months later. Governments often attempt to stabilize prices by purchasing grain and releasing it into the market later, but many operational shortcomings have been experienced in this approach. Smallholder-run storage systems appear to hold greater promise.

Urban tastes are changing with cheap imported grains like wheat and rice. A major reason is their ease of preparation. Research could find ways that local grains could be processed, conserved and marketed, thus claiming back these urban markets for locally-grown grains (Sanders and Shapiro, 2003, 2006). Live-stock feed is another major opportunity. Increasing consumption of meat in the coming decades is expected to increase the demand for animal feed; this could increase the demand for dryland grain crops if varieties and handling methods are optimized for this purpose.

Farmers often sell grains immediately after harvest at low prices in order to meet more immediate demands. In Niger, pilot studies by FAO and partners are testing an 'inventory credit' approach. They ask farmers to place grain in collective stores; loans are issued with the grain as collateral to meet farmer's immediate cash needs. Farmers get additional cash later when the grain is sold at higher prices. This increases their profits from grain farming, and thereby raises their incentive for increasing production through the adoption of new technologies such as water control, fertilizer and improved varieties.

Diversification into higher-value crops and products

Other ways to increase farming income are to grow higher-value crops, and/or create higher-value products from traditional or new crops. Many have advocated diversification to open new income-earning opportunities (Hazell and Haddad, 2001; Leakey et al., 1999;

Ndikumana et al., 2002; Pasternak and Schlissel, 2001; Tengberg and Stocking, 2001). In addition to alleviating poverty, more diverse and profitable crops and crop products encourage farmers to improve soil fertility and water control and adopt improved varieties, as the well-known story of Machakos, Kenya demonstrated (Tiffen et al., 1994). This also stimulates diversification in related agro-enterprises, creating a ripple effect that multiplies the benefits broadly through rural communities (Hazell and Haddad, 2001).

In addition to satisfying local urban demand, specialty crops can tap foreign markets to earn foreign currency for the poor. For export markets though, the entire production, processing, handling and marketing chain must be efficient since international markets demand consistent, high and uniform quality and dependable supplies. The private sector will be essential for linking into international markets, but public sector agencies and NGOs are playing important roles in catalyzing these partnerships, organizing the poor so they produce a reliable stream of sufficient product volume, and ensuring that the poor garner a fair share of the benefits.

Integrating genetic and natural resource management

Water responses are dependent on soil fertility, and vice-versa. Improved variety responses are dependent on both. Market demand and access, and pro-poor policies are required for motivating farmers to seek these responses in the first place. Therefore, an integrated approach to simultaneously alleviate these constraints is essential. A major reason for past failures has been a focus on just one particular intervention or another corresponding to the disciplinary competence of the intervening agency. For integration, broader partnerships are required to bring in a wider range of expertise and farmer participation is critical so that solutions are relevant and adoptable. This process makes research and development more complex.

Subsistence and commercial production perspectives

Subsistence agriculture is important for farmer's food security while commercial production provides the path towards reducing poverty and increasing national food supplies. While conceptually separate, these systems are operationally interlaced. Farmers often do some of each within their farm, and the proportion

may change over time and space. Rather than emphasizing just one or the other, an integrated approach looks holistically at farmer's needs and realizes that both operations are important and require appropriate technology options.

Agricultural development in Africa requires an increasing proportion of commercial systems over time in order to meet growing food needs as well as to reduce rural poverty. The public sector needs to provide continuing assistance on subsistence systems, since those systems offer little opportunity to the private sector. For example, improved seeds of staple grain crops may not be profitable in a subsistence context, but are important for stimulating a transition to more intensive systems (Sanders and Shapiro, 2006). Small-scale machinery such as tied-ridge makers and shallow bore well equipment can advance water management, but often require initial sponsorship and public policies that encourage rural village entrepreneurship (Shapiro and Sanders, 1998). In short, both public and private sectors need to work closely together to foster the gradual transition from subsistence to commercial systems.

Conclusions

The key constraints to technology adoption and agricultural development in drylands relate to in soil fertility, water, crop genetics, and markets. However, integrated genetic and natural resource management approaches have often been lacking in the past. Approaches such as small-scale water conservation/harvesting, fertilizer microdosing, longer-duration varieties, inventory credit management and crop/product diversification for transitioning from subsistence to commercial production are proposed to address the problem. Smallholder-appropriate interventions are more adoptable and could lead to greater progress over time as incremental gains deliver ever-greater farm profitability and therefore stimulate subsequent rounds of increasing investment. They are also more equitable because they are more accessible to the poorest farmers. Both public and private sector engagement are required for success, with the former taking the lead in subsistence agro-ecosystems and the latter assisting farmers as they transition towards commercial systems.

References

- Abdoulaye A. and Sanders J.H. 2005. Stages and determinants of fertilizer use in semiarid African agriculture: the Niger experience. *Agricultural Economics* 32:167–179.
- Ahmed M.M., Sanders J.H. and Nell W.T. 2000. New sorghum and millet cultivar introduction in Sub-Saharan Africa: impacts and research agenda. *Agricultural Systems* 64: 55–65.
- Anderson J. R. 2001. Risk management in rural development: A review. Rural Strategy Background Paper 7. The World Bank, Washington, D.C.
- Aune J.B., Berthe A. and Doumbia M. 2005. Conservation agriculture as an approach to agricultural development in dryland areas of Mali, pp. 239–248. In: Omany, G. and Pasternak, D. (eds.) *Sustainable Agriculture Systems for the Drylands*. Proceedings of the International Symposium for Sustainable Dryland Agriculture Systems, 2–5 December 2003, Niamey, Niger. Patancheru, India: International Crops Research Institute for the Semi-Arid Tropics.
- Bationo A. and Buerkert A. 2001. Soil organic carbon management for sustainable land use in Sudano-Sahelian West Africa. *Nutrient Cycling in Agroecosystems* 61:131–142.
- Boserup E. 1965. *The Conditions of Agricultural Growth: The Economics of Agrarian Change Under Population Pressure*. Aldine, Chicago.
- Breman H. 1992. Desertification control, the West African case: prevention is better than cure. *Biotropica* 24: 328–334.
- Cleaver K.M. and Schreiber G.A. 1994. *Reversing the Spiral: The Population, Agriculture and Environment Nexus in Sub-Saharan Africa*. The World Bank, Washington, D.C.
- Dimes J., Twomlow S., Rusike J., Gerard B., Tabo R., Freeman A. and Keatinge, J.D.J. 2005, pp. 82–92. In: Omany, G. and Pasternak, D. (eds.) *Sustainable Agriculture Systems for the Drylands*. Proceedings of the International Symposium for Sustainable Dryland Agriculture Systems, 2–5 December 2003, Niamey, Niger. Patancheru, India: International Crops Research Institute for the Semi-Arid Tropics.
- Gérard B., Stuber E., Hiernaux P., Yamoah C. and Marchal D. 2001. Gestion de la fertilité des sols et réduction des risques face aux fluctuations climatiques. In *Comment conseiller les producteurs des zones sahéliennes et sahélo-sahariennes face aux risques climatiques, hydrologiques et phytosanitaires*. AGRHYMET 19–23 March 2001.
- Hazell P. and Haddad L. 2001. *Agricultural Research and Poverty Reduction. Food, Agriculture, and the Environment Discussion Paper 34*. Washington, DC: International Food Policy Research Institute.
- ICRISAT 1985–88. ICRISAT Sahelian Center Annual Report, 1984. Patancheru, India: International Crops Research Institute for the Semi-Arid Tropics.
- 1986. ICRISAT Sahelian Center Annual Report, 1985.
- 1987. ICRISAT Sahelian Center Annual Report, 1986.
- 1988. ICRISAT Sahelian Center Annual Report, 1987.
- IFAD 1999. Evaluation du Programme Spécial du FIDA pour les pays d’Afrique subsaharienne touchés par la sécheresse et la désertification. Rapport de synthèse. Rapport no. 924. Rome: International Fund for Agricultural Development.
- Kaboré D. and Reij C. 2004. The emergence and spreading of an improved traditional soil and water conservation practice in Burkina Faso. EPTD Discussion Paper No. 114. Washington D.C.: International Food Policy Research Institute.
- Kay M. 2001. *Smallholder irrigation technology: prospects for Sub-Saharan Africa*. FAO International Programme for Technology and Research in Irrigation and Drainage Knowledge Synthesis Report No. 3. Rome: FAO.
- Krüger H. J., Fantaw B., Michael Y.G. and Kefeni K. 1996. Creating an inventory of indigenous soil and water conservation measures in Ethiopia, pp.170–180. In: Reij C., Scoones I. and Toulmin C. (eds) *Sustaining the soil: indigenous soil and water conservation in Africa*. London: Earthscan Publications Ltd.
- Leakey R.R.B., Wilson J. and Deans J.D. 1999. Domestication of trees for agroforestry in drylands. *Annals of Arid Zone* 38:195–220.
- McCalla A. 2002. The long arm of industrialized countries: how their agricultural policies affect food security, pp. 94–96 in *Sustainable Food Security for All by 2020: Proceedings of an International Conference*, September 4–6, 2001, Bonn, Germany. Washington, D.C.: International Food Policy Research Institute.
- Mortimore M. and Harris F. 2005. Do small farmers’ achievements contradict the nutrient depletion scenarios for Africa? *Land Use Policy* 22: 43–56.
- Ndikumana J., Kamidi R., Desta S., Marambii R., Abdi A.I. and Shori R. 2002. Assessment of possible USAID/OFDA-led activities for increasing resilience of pastoral communities in the Greater Horn of Africa. Addis Ababa: International Livestock Research Institute and ASARECA Animal Agriculture Research Network.
- Niemeijer D. 1999. Environmental dynamics, adaptation, and experimentation in indigenous Sudanese water harvesting, pp. 64–79. In: Prain G., Fujisaka S. and Warren M.D. (eds) *Biological and Cultural Diversity – the Role of Indigenous Agricultural Experimentation in Development*. London: Intermediate Technology Publications.
- Ouedraogo M. and Kaboré V. 1996. The zai: a traditional technique for the rehabilitation of degraded land in the Yatenga, Burkina Faso, pp. 80–84. In: Reij C., Scoones I. and Toulmin C. (eds) *Sustaining the soil: indigenous soil and water conservation in Africa*. London: Earthscan Publications Ltd.
- Pasternak D. and Schlissel A. (eds) 2001. *Combating Desertification with Plants*. Dordrecht, The Netherlands: Kluwer.
- Pender J. 1998. Population growth, agricultural intensification, induced innovation and natural resource sustainability: an application of neoclassical growth theory. *Agricultural Economics* 19:99–112.
- Sachs J.D. 2002. The essential ingredient. *New Scientist* Aug. 17:52–55.
- Sanders J.H. and Shapiro B.I. 2003. Crop technology introduction in semiarid West Africa: performance and future strategy. *J. Crop Production* 9: 559–592.
- Sanders J.H. and Shapiro B.I. 2006. Policies and market development to accelerate technological change in the semi-arid zones: A focus on Sub-Saharan Africa, pp. 879–900. In Peterson, G.A., Unger, P.W., and Payne W.A. (eds), *Dryland Agriculture, Agronomy Monograph no. 23*, 2nd ed. Madison, Wisconsin USA: American Society of Agronomy.
- Sanders J.H., Shapiro B.I. and Ramaswamy S. 1996. *The Economics of Agricultural Technology Development in Sub-Saharan Africa*. Baltimore: John Hopkins University Press. 305 pp.
- Shapiro B.I. and Sanders J.H. 1998. Fertilizer use in semiarid West Africa: profitability and supporting policy. *Agricultural Systems* 56:467–482.

- Shapiro B.I. and Sanders J.H. 2002. Natural-resource technologies for semiarid regions of Sub-Saharan Africa, pp. 261–274. In: Barrett C.B., Place F.M. and Aboud A. (eds), *Towards Sustainable Sorghum Production, Utilization, and Commercialization in West Central Africa*. Tucson, Arizona USA: CAB International of North America.
- Shapiro B.I., Sanders J.H. and Reddy K.C. 1993. Using meteorological information to devise adaptive technology recommendations in the Niamey region of Niger. *Agricultural Systems* 42:153–171.
- Tengberg A. and Stocking M. 2001. Land degradation, food security, and agro-biodiversity – examining an old problem in a new way, pp. 171–185. In: Bridges E.M., Hannam I.D., Oldeman L.R., Penning de Vries F.W.T., Scherr S.J. and Sombatpanit S. 2001. *Response to Land Degradation*. Enfield, New Hampshire, USA: Science Publishers.
- Tiffen M. 2002. The evolution of agroecological methods and the influence of markets: case studies from Kenya and Nigeria, pp. 95–108 in Uphoff, N. (ed.) *Agroecological Innovations*. London: Earthscan.
- Tiffen M. 2003. Transition in Sub-Saharan Africa: agriculture, urbanization and income growth. *World Development* 31:1343–1366.
- Tiffen M., Mortimore M. and Gichuki F. 1994. *More People, Less Erosion: Environmental Recovery in Kenya*. London: John Wiley and Sons.
- Vitale J.D. and Sanders J.H. 2005. New markets and technological change for the traditional cereals in semiarid sub-Saharan Africa: The Malian case. *Agricultural Economics*, 32:111–129.
- Wood A.P. and Rydén P. 1992 (eds) *The IUCN Sahel Studies* 1991. Gland, Switzerland: IUCN – The World Conservation Union.
- World Bank 1995. *Nigeria impact Evaluation Report Kano Agricultural Development Project (Loan 1982 – UNI), Sokoto Agricultural Development Project (Loan 2185 – UNI)*. Washington: The World Bank Operations Evaluation Department.

Factors Influencing Choice and Adoption of Integrated Soil Fertility Management Technologies in Central Kenya Highlands

Mureithi B.M¹., Kimani S.K²., Odera M.M²., Mwangi E.M³. and Gachanja E³.

¹* Corresponding Author, Egerton University, Department of Agricultural Education and Extension, P.O. Box 536, Njoro-Kenya, Tel: 254-722-945976, E-mail: bmmureithi@yahoo.com; ² Kenya Agricultural Research Institute (KARI), Muguga South Station; ³ Ministry of Agriculture, Kirinyaga District

Abstract

The paper presents the findings of a study conducted to determine farmers' perceptions of some of soil fertility management-specific attributes and influence on adoption decisions. The specific objectives were: (i) to determine the relationship between perceptions and choice of integrated soil fertility management (ISFM), and (ii) to evaluate the perceptions among farmers for specific attributes inherent in some of ISFM strategies

Mother trials were established in a centralized place in Mukanduini Village of Central division of Kirinyaga district and Kariti in Kandara, Maragua district during the long rains of the year 2003. Fourteen ISFM strategies were established in the two seasons wherein the farmers were exposed to the fourteen strategies in a participatory manner. It was anticipated that after the initial exposure to the technologies, the farmers would be encouraged to replicate the same on their farms within the constraints of resource endowment and preference considerations.

The results of the project activities revealed the following: (i) Majority (70.2%) of the willing participants were predominantly male (ii) Majority (52.6%) of the participating farmers had below secondary school level of education, (iii) the participants were elderly (49.0 years average), (iv) the average farm size in across the two villages was 1.92 acres (std. dev. = 1.7), (iii) approximately 73% of the farmers confirmed that availability of the inputs used in the ISFM strategies is important, (iv) about 98.2% of the farmers confirmed that use of some of the ISFM strategies resulted in enhanced crop growth vigour, (vii) majority of the farmers (66.7%) did not find labour associated with the use of technologies an important factor in determining their adoption decisions, (viii) about 94.7% of the farmers consider use of Tithonia a viable ISFM option, (ix) approximately 38.6% of the farmers consider cost implication of the technologies an important factor in determining their adoption decisions, and (x) use of green manures is not a preferred ISFM option but fertilizer manure mixtures produce favourable results hence attractive to over 70% of the farmers.

The study concludes that future technology up-scaling efforts put into consideration the farmers' prevailing circumstances and the identified farmer preference considerations in promotional strategies

Introduction

Research into ways and mean of improving food production has been going on for a long time. Since 1955, 20 varieties of high yielding maize varieties have been released covering a wide range of agro ecological zones (KARI, 1993). These have been adopted by

farmers to different levels but the yield gains have been low despite agronomic packages being developed for the improved varieties. One of the main reasons for low yield gains has been depletion of soil fertility in most sub-Saharan Africa (Sanchez and Leakey, 1997). This depletion is the result of many factors including continuous cropping without adequate replenishing

of nutrients, nutrient loss through harvesting of produce (mining) leaching, soil erosion and volatilization (Bationo, 2003). This has resulted in much more than just lowered food production (by as much as 2–4 times (Bationo, 2003), but also other socio economic consequences such as reduced water systems capacity, land slides and floods.

The liberalization of the agricultural inputs sector has had fertilizer prices going up, thus reducing their usage. Fertilizer use has also gone down due to unavailability when needed and the poor resource base of farmers especially the small scale farmers to the extent that they are unaffordable (Makokha et al., 2001). Fertilizers add nutrients to the soil but contribute less to the building of soil organic matter and hence soil structure. Organic materials on the other hand have limitations like bulkiness, low nutrient levels and high labour requirements, although they perform other important functions in maintaining soil fertility like improving soil aeration, alleviating soil acidity and toxicity, increase infiltration, increasing water-holding capacity, reduce leaching and decrease erodibility (Kihanda and Gichuru, 1999). It therefore follows that none of these can alleviate the problem independently. Soil fertility management therefore requires more than the addition of nutrients to the soil.

The social, economic and political environment is important in the process of mitigating soil fertility depletion. This is because the social, economic and political circumstances differ from place to place and from farmer to farmer in addition to the biophysical variation. It is not easy to give blanket recommendations. ISFM as an approach to alleviating soil fertility decline considers all the factors that, in one way or another, will influence the process of soil fertility management (Kimani et al., 2003). Many ISFM components and technologies have been developed which are tailored to fit different geographic and social economic areas and categories of farmers, especially smallholder farmers (Snapp et al., 1998). To enhance their uptake and adoption it is important to understand the decision-making processes of the farmers. The understanding of the process will help in determining which technologies fit best where as determined by the characteristics of the target groups and the technologies themselves. It is also important to know the farmers perceptions of the technologies as these impact on the adoption decisions (Adesina and Baidu-Farson, 1995).

Through Participatory Learning and Action Research (PLAR), the farmers' awareness of the variety of ISFM

options available and how they compliment or substitute one another is expanded. This participation helps them understand what is involved in practicing the ISFM technologies while the variety of options gives ISFM the flexibility to accommodate the variations in social economic status of farmers (Ouma et al., 2003). Based on this awareness and understanding, the farmers can make informed decisions on which options fit their individual circumstances. This process also gives the farmer a chance to adapt the technology to his farming system instead of adopting it from a purely scientific point of view (de Villiers, 1996).

The objective of this study was to find out what farmers put into consideration when deciding on soil fertility management measures and also how these considerations influence their preferences for the ISFM technologies they have been exposed to.

Materials and methods

Study site

The study consisted of two sites in two middle altitude districts of central Kenya. Maragwa district is on the eastern slopes of the Aberdares range. It has an area of 1065 km² and has projected population of 409,299 (MoA, 2003) and a density of 384 persons per km². There are two rainy seasons March–May (long rains) and October–December (short rains). Altitude ranges from 1100–2950m a.s.l., while average annual rainfall ranges from 900–2700 mm p.a. The average farm size is 0.93 ha.

Kirinyaga district is on the Southern slopes of Mt Kenya, covering an area of 1437 km² and a projected population of 490,974 and density of 342 persons per km². The average farm size is 1.25 ha (MoA, 2001). Both districts have representative characteristics of the central Kenya Highlands namely high population densities, high levels of land fragmentation, deep well drained, dark reddish to dusky red volcanic soils. The topsoil is acid and easily erodible. They have low to moderate inherent fertility. Decline in soil fertility has occurred through continuous cropping without nutrient replenishment, and soil erosion. Most of the farm holdings are small scale averaging less than 2 ha with mixed farming being predominant. Subsistence crops mainly maize, beans, potatoes and bananas as well as cash crops such as coffee are grown. Maize has been performing poorly in the last 10–15 years greatly lowering the resource base of the pleasant farmers. This

coupled with liberalization has reduced use of fertilizers to very low levels (Hassan, 1998). All these factors have resulted in maize production levels reducing to as low as 1.5 tons ha⁻¹ (MoA, 2002) while the potential is 6 tons ha⁻¹ (Makokha et al., 2001). This has serious implications on food security considering small holder farmers produce 70% of the maize consumed in the country (Ouma et al., 2002) and that maize makes up 40% of the food requirements of Kenya.

During the long rains (April 2003) researcher-managed mother trials were set up in the two sites, Mukandu-ini and Kariti areas of Kirinyaga and Maragwa districts respectively. Randomized complete block design (RCBD) was used with 3 replicates of 15 different soil fertility management treatments. The plots measured 4 × 6 m with maize (*Zea mays*) used as the test crop. The varieties used were C4141 in Mukandu-ini and H513 in Kariti at a spacing of 90 cm × 30 cm. 1 row of field beans (*Phaseolus vulgaris*) planted as an inter crop between rows of maize in all the plots except those with the green manure cover crop (GMCC). The three green manure cover crops used were dolichos (*Dolichos lablab*), velvet bean (*Mucuna pruriens*) and sun hemp (*Crotalaria grahamiana*).

The list of all treatments is shown below:

- T1 – Unfertilised control
- T2 – Manure +Fertilizer (5t ha⁻¹; 20kg N ha⁻¹)
- T3 – Manure + fertilizer (5t ha⁻¹; 40 kg N ha⁻¹)
- T4 – Manure + fertilizer (5t ha⁻¹; + 60kg N ha⁻¹)
- T5 – Manure + fertilizer (5t ha⁻¹; +80kg N ha⁻¹)
- T6 – Compost (10t ha⁻¹)
- T7 – Maize Stover (5t ha⁻¹ + EM1)
- T8 – Maize stover Alone (5t ha⁻¹)
- T9 – Tithonia (5t ha⁻¹)
- T10 – Mucuna
- T11 – Crotalaria
- T12 – Dolichos
- T13 – Fertilizer (100kg ha⁻¹)
- T14 – Manure (5 t ha⁻¹)
- T15 – Manure (10 t ha⁻¹)

Maize was initially planted two per hole and later thinned to one per hole. Mucuna and Dolichos were planted in rows 50cm × 20cm within the maize rows while Crotalaria was drilled at a spacing of 90 cm. The manure and compost used were of high quality. Mineral N was supplied from NPK (17:17:17) and a blanket rate of 40kg ha⁻¹ P from TSP was applied in all plots except the control. All agronomic practices were done

as recommended with two hand weeding at 4 weeks and at flowering.

A farmers field day was organized in each site at the silking stage of the maize crop farmers were shown through the different treatments by officers from KARI and MoA Extension. Explanations were given about the treatment in each plot. During the registration farmers were picked at random and a questionnaire given for them to fill after going through the plots. This was aimed at capturing their preferences of the various treatments based on what they saw and the explanations given by the staff. A total of 57 farmers were sampled 26 from Kariti and 31 from Mukandu-ini. Analysis was done using the SPSS package.

Results and discussion

Gender distribution by site

Kariti had 26 people while Mukandu-ini had 31. Of the people from Kariti 63.3% were males compared to 30.7% females (Table 1). Mukandu-ini had 70.0% males with 30% females. Males made up 70.2% of the study group while females made up 29.8%. When the two sites are compared using the Chi-square, they show no significant difference (0.020 at a=0.05 while expected value is 3.841), hence they can be taken to be not different.

Age and farm size

Table 2 below compares the ages and farm size of the two areas. From this table, the average age of farmers at Kariti (51.3) is higher than that of Mukandu-ini (47.2) but there was wider variation in Kariti than Mukandu-ini. The average farm size in Mukandu-ini (2.27 acres) is higher than that of Kariti (1.50 acres). A comparison of the means for the two variables showed no significant difference.

Table 1. Gender distribution by site of Kariti and Mukandu-ini

Gender	Kariti		Mukandu-ini		Total	
	Count	%	Count	%	Count	%
Male	18	69.3	22	71.0	40	70.2
Female	8	30.9	9	29.0	17	29.8
Total	26	100	31	100	57	100

Table 2. Comparison of ages and farm size of farmers in Kariti and Mukandu-ini

Site	Kariti		Mukandu-ini		Total	
	Mean	Std. dev	Mean	Std. dev	Mean	Std. dev
Age (yrs)	51.3	12.3	47.2	10.6	49.0	11.51
Farm size (acres)	1.5	1.58	2.27	1.75	1.92	1.7

Education level

Only 7% of the respondents had no formal education, 45.6 went up to primary and 47.4% had secondary and higher levels of education (Table 3). Mukandu ini has higher literacy levels than Kariti as 64.9% went to secondary and above while Kariti had only 38.5%. All males had some form of education but 23.5% of females had no formal education, but the post secondary levels had almost equal figures.

Influence of technology specific attributes on adoption

Farmers in Kariti consider crop growth vigour (80.8%), skill required to practice the technology (84.6%) and crop yields (96.2%) as important attributes when considering whether to adopt a soil fertility management technology while cost of inputs (34.6%) and the reliability of the supply of the inputs (23.1%) are not considered important (Table 4). On the other hand, farmers in Mukandu-ini consider growth vigour (96.8%), availability of required inputs (87.1%), yields (93.5%) and reliability of the input supply (71%) important when making decisions on what to adopt, but to them labour requirements (19.4%) and convenience of practicing (19.4%) are not important. Cost of inputs and skills required are not considered either way. Clearly, growth vigour (98.2%) and yield resulting from practicing a soil fertility management technology

(94.7%) are considered critical in the farmers' decision-making process in both areas. But they differ on the importance of the convenience of practicing and reliability of supply of inputs required to practice the technology (Table 4) To farmers in Mukandu-ini, if a technology shows good crop response, the inputs required are available, their supply is reliable and the yields are good, then it stands a chance of being adopted. In Kariti, if a technology shows good crop response, it is easy to practice and the yields are good, it stands a chance.

This may be partly explained by the sources of labour in the two localities. While labour in Kariti is mainly hired, in Mukandu-ini it comes mainly from the family. Family labour can be employed to implement any technology as long as the expected yields, vigour of crop and inputs are available and reliable in supply. Hired labourers might not be willing to do those very tedious and demanding jobs required of some of the ISFM technologies. There is a difference in the influence of inputs. In Mukandu-ini, it is an important consideration in adopting a technology but in Kariti, it is not that critical. This can be explained by the fact that Kariti is near sources of inputs especially those like fertilisers and the distribution system is reliable. Hence the risk factor is highly reduced but becomes an important consideration to Mukandu-ini as the risks are higher. Also the dairy production is more developed in Kariti than in Mukandu-ini, so manure is more available and of better quality, which reduces the farmers' worry about its availability. Farmers in Kariti use crop residues to feed

Table 3. Farmers education level by site

Level of Education	Kariti		Mukanduini		Total	
	Count	%	Count	%	Count	%
None	3	11.5	1	3.2	4	7.0
Primary	13	50.5	13	41.9	26	45.6
Secondary	8	30.8	15	48.4	23	40.4
Post secondary	2	7.7	2	6.5	4	7.0
Total	26	100	31	100	57	100

Table 4. Influence of technology specific attributes on adoption by farmers in Kariti and Mukandu-ini (figures in %)

Site	Kariti		Mukandu-ini		Total	
	Yes	No	Yes	No	Yes	No
Farmer response						
Growth vigour	100	0	96.8	1.8	98.2	1.8
Convenience of practicing	80.8	19.2	19.4	80.6	41.4	52.6
Labour requirements	50	50	19.4	80.6	33.3	66.7
Availability of inputs	57.5	42.3	87.1	12.9	73.7	26.3
Cost of inputs	34.6	65.4	41.9	68.1	38.6	61.4
Skills required	84.6	15.4	48.4	51.6	64.9	35.1
Effect on yields	96.2	3.8	93.5	6.5	94.7	5.3
Reliability of supply of inputs	23.1	76.9	71	29	49.1	50.9

livestock and generate manure while their counterparts in Mukandu-ini sell to buy manure or fertiliser. So it becomes an important consideration for them.

Chi square analysis shows there are significant differences between the two sites in terms of convenience of practicing, labour requirements, inputs availability and reliability and skills required to adopt a technology but not the other attributes.

Farmers' preferences for adoption

Having seen all the fourteen treatments, the farmers were asked to indicate which of them they prefer as potential for adoption considering the attributes of the treatments as shown in Table 5 and their own individual circumstances. The results indicate a high preference for manure at 10 tons ha⁻¹, fertiliser manure mixtures

at 5 tons manure and 40, 60 and 80 kg N ha⁻¹ and tithonia (94.7%). Fertiliser at 100 kg N ha⁻¹ had only 50% interested.

This could be attributed to the cost of applying that high rate of fertiliser. Not many can afford. Manure at 10 tons ha⁻¹ was highly preferred (80.7%) while at half this rate, only 45.6% showed preference. But compost at the same rate (10 ton ha⁻¹) didn't generate the same interest. Making this amount of compost would be difficult, most probably not viable. All the other organic material treatments had less than 30% preference.

The preference patterns can be attributed to crop performance, cost of materials required and availability. Manure is generally available as a result of the zero grazing system and most farmers can afford the amounts of fertilisers required for the mixed treatments. The green manure cover crops may have low preference levels because they had not been incorpo-

Table 5. Preferences for ISFM technology adoption by farmers in Kariti and Mukandu-ini villages

Treatment	Percentage responses	
	Yes	No
Compost 10 t ha ⁻¹	26.3	73.7
Maize stover 5t ha ⁻¹ +EM1	8.8	91.2
Manure 10 t ha ⁻¹	80.7	19.3
Tithonia 5 t ha ⁻¹	94.7	5.3
Manure 5t+20Kg N	47.4	52.6
100Kg N	49.1	50.9
Manure 5t+40Kg N	73.7	26.3
Manure 5t+80Kg N	61.4	38.6
Maize stover 5t ha ⁻¹	21.1	78.9
Manure 5t ha ⁻¹	45.6	54.4
Dolichos	12.3	87.7
Mucuna	21.4	78.6
Manure 5t+60Kg N	87.7	12.3
Crotalaria	29.8	70.2

rated as is recommended. So their expected effect could not be observed during the first season. Another possible reason is that the farmers may not know where to get the seeds of the cover crops. Dolichos especially may be available in the market but it is used as food. It therefore might not be a farmer's priority to use it as green manure. Stover is mainly used as animal fodder where farmers can get milk as well as manure. This coupled with its low N levels and hence poor crop response does not appeal to farmers as a soil fertility material. Tithonia grows wild in both areas where farmers can harvest it easily and use it in the soil cheaply. It is also easy to practice this one. This could be why it was highly preferred. In general the farmers could reject a technology if it does not show good crop response, which associated with good yields, and it is costly.

Conclusions

The results confirm that farmers are different in their perceptions ISFM of technologies. The discussion has shown that there exist variations in what farmers consider important when deciding which technologies to try out on their farms. There has also been indication that these considered attributes determine their choice of technologies the farmers are willing to try out and may be eventually adopt. Farmers could reject a technology if it does not show good crop response, which is associated with good yields. A technology that competes for inputs with more beneficial activities stands a poor chance of adoption. This is much so if the other technology or activity has immediate gains to the farmer. It is also necessary for the inputs required to be available and in a sustainable manner. This ensures long-term benefits to the farmer. It is therefore important to establish the extent to which these factors are favourable for any technology to ensure that it receives favourable response from the farmers. Every situation should be treated on its own merits. Another important considerations is introducing a range of options if possible to give the farmers room for flexibility in choice according to their own situations and assessments.

Acknowledgements

The authors wish to thank the Rockefeller Foundation for the financial support for the field activities.

Much appreciation goes to the staff of KARI Muguga South and TSBF-CIAT for their contribution and support. Finally, we would like to appreciate the help from the extension staff in Kirinyaga and Maragwa districts. Their support and contribution were worthwhile.

References

- Adesina A.A. and Baidu-Farson, J. 1995. Farmers perceptions and adoption of new agricultural technology. Evidence from analysis in Burkina Fasso and Guinea, West Africa. *Elsevier Journal of Agricultural Economics* 13: 1-9
- Bationo A. 2003. Introduction pp. xiv-xvi In: Gichuru M.P., Bationo A., Bekunda M.A, Goma H.C., Mafongoya P.L., Mugendi D.N., Murwira H.M., Nandwa S.M., Nyathi P. and Swift M.J. (eds). *Soil Fertility Management in Africa: A Regional Perspective*. Academy Science Publishers Nairobi, Kenya.
- De Villiers A. K. 1996. Quantifying indigenous knowledge: a rapid method for assessing crop performance without field trials. *Agricultural Research and Extension Network, AgREN Paper No. 66*.
- Hassan R.M. 1998. *Maize Technology Development and Transfer, A GIS Application for Research Planning in Kenya*
- KARI 1993. *Strategies for future maize research*. Proceedings of a national maize workshop. Kenya Agriculture Research Institute (KARI), NARL, Nairobi, Kenya.
- Kihanda F.M. and Gichuru M. 1999. *Manure management for soil fertility improvement TSBF/AHI Report*.
- Kimani S.K., Nandwa S.M., Mugendi D.N., Obanyi S.N., Ojiem J., Murwira H.K. and Bationo A. 2003. *Principles of Integrated Soil Fertility Management*. In: Gichuru M.P., Bationo A., Bekunda M.A, Goma H.C., Mafongoya P.L., Mugendi D.N., Murwira H.M., Nandwa S.M., Nyathi P. and Swift M.J. (eds). *Soil Fertility Management in Africa: A Regional Perspective*. Academy Science Publishers Nairobi, Kenya.
- Macokha S., Kimani S., Mwangi W., Verkuijl H. and Musembi F. 2001. *Determinants of Fertilizer and Manure use in Maize Production in Kiambu District, Kenya*. Mexico, D.F: CIMMYT and KARI.
- MoA 2001. *District annual report Kirinyaga District*.
- MoA 2002. *District farm management guidelines Kirinyaga District*.
- MoA 2003. *District farm management guidelines Maragua District*.
- Ouma J., Muriithi F., Mwangi W., Verkuijl H, Gethi M. and De Groote H. 2002. *Adoption of Maize seed and fertilizer Technologies in Embu District, Kenya*. Mexico, D.F. CIMMYT.
- Sanchez P.A. and Leakey R.R.B. 1997. *Land use Transformation in Africa: Three Determinants for balancing Food Security with Natural Resource utilization*. (*Eur. J. Agron*) 7: 1-9.
- Snapp S.S., Mafongoya P.L. and Waddington S.R. 1998. *Organic matter technologies for integrated nutrient management in shall holder cropping systems in small holdercropping systems of southern African*. *Agriculture Ecosystems and Environment* 71: 185-200.

Social capital and adoption of soil fertility management technologies in Tororo district, Uganda

Lule Ali¹, N. M. Mangheni¹, P. C. Sanginga², R.J. Delve³, F. Mastiko¹, R. Miiri¹

¹Department of Agricultural extension Makerere University P.O. BOX 7062, KAMPALA UGANDA; ²International center for tropical Agriculture (CIAT) P.O. Box 6247, Kampala Uganda; ³Tropical soil Biology and Fertility institute of CIAT. P.O Box 6247, Kampala, Uganda

Abstract

Sustainable agricultural production demands that appropriate technologies are adopted to ensure adequate replenishment of soil nutrients. Thus a variety of soil fertility management technologies have been promoted to help sustain fertility levels of soils in Tororo district by INSPIRE project. However, despite these efforts, there is low adoption of these technologies. Various studies indicate that social capital is crucial for adoption of soil fertility management technologies as it provides social networks, relationships and linkages that enable poor people to cooperate, coordinate, share information and resources, and act collectively. Social capital is the ties, networks and linkages between individuals, groups and communities that bind and bridge society. A survey involving structure questionnaire, focus group discussion and participatory diagramming (network analysis) was conducted with 103 female and male farmers in two sub-counties, Usukuru and Kisoko in Tororo District to investigate the levels and dimensions of social capital and their influence on adoption of soil fertility management technologies. Logit regression model results showed that the probability of currently using legume cover crops (tithonia biomass transfer, canarvalia, tephrosia and mucuna) was higher for farmers who belonged to groups compared to other community members. Social capital variables such as the extent of cooperation, the extent of information sharing, and linkages with external agencies significantly increased the probability of adoption of these legume cover crops. Farmers' groups performed better on such indicators of social capital as cooperation, extent of trust, information sharing and participation in collective activities. On the other hand, indicators of weak ties such as selfishness, individualism and conflict are higher in the general community than farmer's groups. There was higher adoption in farmers groups implying that social capital influences adoption of technologies. It is therefore recommended that strengthening local organizations and intensifying multipurpose cover crops would increase adoption of soil fertility management technologies

Key words: Social capital, Soil fertility management technologies, Adoption, INSPIRE project

Introduction

Soil fertility depletion on smallholder farms has been cited as the fundamental biophysical root cause of the declining per capita food production in Africa (Sanchez et al., 1997; Stoorvogel and Smaling, 1990). This is because little inorganic fertiliser is used, resulting in negative nutrient balances for cropland. In Uganda, low soil fertility has been attributed to low levels of

use of inorganic fertilizers, and exhaustion, poor management, mining of soil nutrients, and high rates of soil erosion (Zake, 1999; Wortman and Kaizzi, 1998). For example, in 1983, the estimated soil nutrient losses in Uganda exceeded nearly 70 kilograms of nitrogen (Stoorvogel and Smaling, 1990).

Also, inadequate vegetation cover on crop lands, shortening of fallow periods and limited adoption of water and soil conservation measures

have increased soil fertility decline (Bojo (1994); Sanchez et al., 1997).

Soil fertility decline has impacted on people's livelihoods through decline in land productivity (Young, 1994), food insecurity, and reduced revenues from agricultural goods (Sanchez et al., 1997). Other indirect consequences include the decline in foreign exchange earnings, especially for a country like Uganda whose major source of foreign exchange is agricultural products.

In Uganda, low agricultural productivity has been blamed on lack of adoption of agricultural technologies, which are crucial for modernisation of agriculture (Semana, 1998). However, this is not surprising, given the fact that even in the rest of Sub-Saharan Africa, the rate of adoption of soil fertility management technologies has been low (Thomas and Sumberg, 1995; Enyong et al., 1999). Most studies on adoption in Uganda tend to concentrate on constraints in farming systems, and characteristics of individual farmers or households. As a result, there is little information on other factors such as social capital that may affect adoption (Esilaba et al., 2001; Isham, 2000; Hazell et al., 1997). These studies indicate that social capital plays an important role in technology adoption although they do not investigate community social capital, versus group or individual social capital. This study looked at these dimensions of social capital, so as to better appreciate its influence on adoption of soil fertility management technologies.

Social capital is a concept with different definitions. According to Putnam (1993), social capital refers to the features of social organisations, for example Trust norms and networks that can improve efficiency of society by facilitating co-ordinated action and determine how easily people work together. Coleman (1988) defines it as "the ability of people to work together for common purposes in groups and organisations". This paper construes social capital to mean the ties, networks, and linkages between individuals, groups, and communities that bind and bridge society.

In Uganda, national agricultural research stations and NGO's, have tried to promote the use of legume cover crops and shrubs in some districts. Such efforts have taken root in Tororo district through a consortium involving civil society, NGO's, national agricultural research systems, international agricultural research systems, and government administration. This umbrella project – Integrated Soil Productivity Initiative through Research and Education (INSPIRE) started in 1997 in Tororo District (Waata et al., 2002).

The INSPIRE project uses participatory technology development (PTD) approach to disseminate the technologies. This approach enables a wide coverage of categories of farmers, in the promotion of integrated nutrient management technologies (Miuro et al., 2000). According to Van Veldhuizen, Wafers Bayers and De Zeeuw (1997), PTD is the process of purposeful and creative interaction between rural people and outside facilitators. It is the working together of scientists with farmers to identify, test, evaluate and disseminate new agricultural technologies, as well as a people-centred aim to strengthen local capacities to experiment and innovate (Miuro et al., 2000).

The approach uses the notion of interactive participation where people are involved in analysis, leading to action plans and the formation of new local institutions or strengthening the existing ones. It also promotes identification and use of networks, knowledge sharing, use of formal and informal rules and traditions. In sum, this approach relies heavily on three organizing aspects or features of society – the people's social capital, in realizing its goals. The technologies being promoted include leguminous trees /shrubs and cover crops such as *Mucuna* (*Mucuna Preuriens Var Utilis*), *Canavalia* (*Canavalia ensiformis*), *Tephrosia* (*Tephrosia candida*, *Tephrosia vogelli*).

The literature mainly reflects experiences and particular emphasis on the dynamics surrounding adoption of legume cover crops, factors determining adoption like the attributes of an innovation and socio-economic factors. Little if anything is mentioned about other factors in the social fabric of society that might influence adoption. When these are mentioned, it is only in passing and no emphasis is laid on how they influence the adoption of soil fertility management technologies. Despite recognition that social capital is vital for adoption of agricultural technologies, little empirical research has endeavoured to examine the role it plays in the adoption of soil fertility management technologies. This scenario is even worse in Uganda where studies in social capital are limited, and have been devoted to other concerns, and not the role of social capital on adoption soil fertility management technologies. A study to look into this strand of social capital has therefore been timely.

This paper presents findings of a study conducted in 2002 with the objectives of establishing the levels and dimensions of social capital in the community and its influences on adoption of SFMTs. Understanding the relationship between social capital and adoption of SFMTs may provide a basis for improvement in the

efforts of those involved in the development and dissemination of these technologies. It is also envisaged that policy makers would benefit from such information in the design and implementation of “appropriate” policies that take into account the central role of the organising aspects of society in the development process. Such knowledge would also benefit farmers in their day-to-day farming activities.

Methodology

A cross-sectional survey involving members and non-members of farmer’s groups was conducted. Both qualitative and quantitative data was sought using questionnaire and focus group discussion guide. Usukuru and Kisoko Sub-Counties in Tororo district where this study was carried out have a population density of 270 Km² (National Housing and Population Census, 1991). The population in these areas is predominantly involved in subsistence agriculture, with an average land holding of 1–2 hectares. The study area was purposively selected since it has been a focal point for dissemination of SFMTs in the INSPIRE project. Participants were selected using multi-stage cluster sampling techniques. Two Parishes were selected from each Sub-County, and from these parishes four villages were chosen using systematic random sampling. From each village, 8 male and 12 female farmers belonging to various farmers’ groups were selected. A total of 106 respondents participated in the study. The researcher obtained lists of farmers from the District Chairperson of farmer’s Association and Africa 2000 network with the names of all farmers’ (both those in groups and non group members). Lists of community members were obtained from Local councils. Using the fish and bowl method, researcher and research assistants proceeded to pick names of farmers from folded papers. Sampling was without replacement. This was to ensure every farmer had an equal chance of being selected to participate in the study. Four focus groups discussions were also conducted, 2 from each Sub-County with the aim of capturing in depth information on social capital and adoption of SFMTs.

Quantitative data was analysed using SPSS (version 8.0). We used descriptive statistics and Logit regression model. Logit model because of the nature of the dependant variable, which was dichotomous hence, being unsuitable for analysis by other multivariate statistical techniques (Bohrnstedt and Knoke, 1988). This model (for details see Madalla, 1983) has found several empirical applications in the adoption literature

(Adesina and Zinnah, 1993; Gujarati, 1988; Sanginga, 1998). The model framework used in the maximum likelihood method:

$$Q_{ik} = F(I_{ik} = e^{z_{ik}} / (1 + e^{z_{ik}}))$$

For $Z_{ik} = X_{ik}\beta_{ik}$ and $-\infty < Z_{ik} < \infty$

Where Q_{ik} is the dependent variable that takes on the related value of 1 for adoption of legumes cover crops by the farmers and 0 otherwise. X_{ik} is a matrix of explanatory variable related to the adoption of legume cover crops by farmer i and β_{ik} are the vectors of parameters to be estimated. I_{ik} is an implicit variable that indexes adoption, while $F(I_{ik})$ is the probability that the i th farmer adopts legume cover crops/Shrubs and 0 otherwise. X is assumed to be a function of sets of factors: (i) S a vector of social economic characteristics of a farmer, (ii) V a vector of farmers’ assessment of legume cover crops/Shrubs, and (iii) I , a vector of structural and institutional (social capital) factors. The adoption decision is specified as $Y = \eta(X, e)$, where e is an error term with logistic distribution.

Among the independent in variables of interest was level of education, group membership, and level of participation in community activities or farmers group activities (weeding, harvesting, planting, attending meetings and events) and decision making in the community level. These were examined to determine their relationship with adoption. Also, qualitative data was subjected to content analysis, to identify the major themes. Analysis was done during and after data collection. Data obtained from focus group discussions was the main focus in this analysis.

Results and discussion

Measures of social capital

In this study social capital was measured at individual, group and community levels. The indicators used were: extent of cooperation among farmers in groups and in the community, extent of participation in community activities or farmers group activities (weeding, harvesting, planting, attending meetings and events), extent of trust among people, extent of financial contribution in solving common problems (training of farmers, weeding, harvesting), extent of information sharing among people in farming activities, extent of conflict among people in farming activities (land wrangles and theft)

and extent of individualism and selfishness in farming activities (weeding, harvesting and planting). All the variables were measured on a three-point scale: 1 – low, 2 – average and 3 – high.

Table 1 shows the results of the assessment of the social capital indicators in groups and community. Indicators with relatively high levels of social capital in groups include extent of trust among people, unity among people, extent of financial contribution in solving common problems, information sharing within people on farming activities, cooperation among people while extent of conflict and individualisms among the people in farming activities had the lowest percentage. On the other hand, high levels of group activities registered the highest in community; cooperation among people while extent of conflict and individualisms among the people in farming activities had the lowest. On the other hand high levels of group activities registered the highest in community but with low values compared to that in groups. In the first column within groups and in community conflict and individualism indicated high percentages of being low in groups than in community. From the table it is clear that groups have higher indicators of social capital compared to the entire community.

Membership in local associations/groups was also found to be very vital for harnessing social capital relevant for adoption of technologies. More group members compared to non-group members were found to be currently using legume cover crops and shrubs. This is attributed to the fact that people tend to adopt at group level than individual level due to social pressure (Rogers, 1983). In addition, it implies that members of groups may have more access to information, have more trust, co-operation and unity than non-members.

Conversely, non-group members may not share some of the benefits accruing from groups, and may be afflicted by conflicting relationships.

Results from participatory diagramming with group members further indicate existence of strong linkages between village local groups, formal service providers, and other local groups outside the village. Existence of such linkages in different organisations in society indicates presence of social capital. Warfarin group in Kisoko Sub-County has strong linkages with such service providers as Africa 2000 network, and other groups outside the village, including, Women Guild Group, Kuringi Marwango Group. This group also maintains weak links with Tororo District Farmers' Association (TODIFA), Kulika, Plan International, and FOSEM service providers, and with Theke Theke, Tekere, Chingimarowo and Frontier groups. Farmers belonging to Wafuriwin group therefore have strong bonding and bridging social capital (indicated by the linkages), and are in a better position to adopt technologies developed and disseminated by service providers like Africa 2000 Network. This analysis was also carried out with other groups like Temo-Kinyeko in Kisoko Sub-County, and the findings indicated strength of networks and linkages. These findings reported on improving integrated nutrient management practices on smallholder farms in Africa (Esilaba et al., 2001).

Levels of adoption for members of groups and non members

The results of adoption are presented in Table 2. The different levels of group and to non-members show highly different adoption of the technologies. In the

Table 1. Farmers' perception about levels of social capital in group and community

Variables	Low %		Average%		High %	
	Group	Non-group	Group	Non-group	Group	Non-group
Cooperation	–	7.3	10.9	34.1	89.1	58.5
Participation in community activities	–	9.8	15.2	31.7	84.8	58.5
Extent of trust	–	9.8	6.5	31.7	93.5	58.5
Unity among people	–	2.4	6.5	34.1	93.5	63.4
Extent of giving or exchanging gifts	2.2	7.3	15.2	29.3	82.6	63.4
Financial contribution in solving common problems	–	12.5	6.5	25	93.5	60.0
Spirit of helping each other	–	14.6	8.9	14.6	91.1	70.7
Extent of conflict among people in farming activities	89.1	12.2	8.7	19.5	2.2	68.3
Extent of individualism or selfishness	93.5	63.4	4.3	26.8	2.2	9.8
Group activities or collective problem solving	–	14.6	8.7	14.6	91.3	70.7
Information sharing	2.2	2.4	6.5	29.3	91.3	68.3

group farmers' adoption (currently using) was high with technologies such as *Tithonia* biomass transfer as it is readily available to farmers and can survive persistent drought spell, *canavalia*, *mucuna* and *calliandra* followed in the order. Among group member the highest percentage to abandon technology use was *mucuna*. This is probably due to the competition with the main crop and the high loss of dry biomass.

Looking at the non-member of groups, *tithonia* and *crotalaria* were currently used more than other technologies. This may be attributed to being readily available to farmers. *Tephrosia* had the highest percentage as being abandoned among non-group members probably due to high incidence of pest attack. Generally farmers in groups had high percentages of technology of adoption (currently using) than non-members. This means that farmers who belong to groups are likely to adopt these technologies than other community members. Therefore if we take our hypothesis, that adoption is a function of social-economic factors, social capital and attributes of the technology, it would become clear that there would be more adoption among group members with higher social capital than other members of the community. The above finding agrees with Feder and Slade (1994); Rogers (1983) and Adams (1998) as cited in Isham (2002), who found that social groups can influence the adoption of new innovations. This means that farmers who belong to groups are more likely to adopt these technologies than other community members.

Influence capital on adoption of soil fertility management technologies

Further analysis of factors affecting technology adoption was done using the logit model. The variables of

interest were age, education, extent of co-operation, contact with extension workers, size of land (acres), information sharing and extent of conflict in the community (Table 3). Results show that only six variables are statistically significant in explaining farmer's adoption of legume cover crops. The frequency of extension visit by agent was highly significant, at 1% level of significance. Group membership was positively significant with a t-ratio of 2.08, at 5% level of significance. Education was significant with secondary level but negatively related to adoption. This implies that farmers do not need high levels of education to perceive these technologies.

The extent of co-operation among farmers was positively significant and therefore was found to be affecting adoption of legume cover crops. These findings reveal that moving from average to high co-operation will significantly increase adoption. This may be partly due to the high co-operation among group members that brought the high use of legume cover crops than that among community members.

Information sharing was positively significant indicating that moving from average to high information sharing increase adoption of legume cover crops and shrubs. However, the negative sign on low information sharing shows a decrease in adoption of legume cover crops and shrubs. This is explained by the principle that farmers need information first to adopt an innovation (Rogers, 1983; Isham, 2002).

The extent of conflict was negatively related to adoption of legumes cover crops. This implied that high conflict has negatively significant impact on adoption. Moving from low conflict to high conflict would drastically decrease adoption. These results agree with Tumwegamire and Mwebesa (1999), who established that adoption of soil fertility management technologies

Table 2. Use status of different technologies among members and non-group members

Technologies	Never used %		Currently using %		Abandoned %	
	Group	Non-group	Group	Non-group	Group	Non-group
<i>Calliandra</i>	7.3	–	24.0	–	1.8	–
<i>Canavalia</i>	10.9	16.7	29.1	9.5	–	–
<i>Crotalaria</i>	12.7	16.7	14.6	11.9	1.8	–
<i>Lab-lab</i>	20.0	11.9	9.1	7.2	–	2.4
<i>Leuceana</i>	20.0	14.3	9.1	7.1	1.8	–
<i>Mucuna</i>	14.5	21.4	25.4	7.1	7.3	–
<i>Sesbania</i>	12.7	14.3	20.0	7.2	–	–
<i>Tephrosia</i>	12.7	14.3	20.0	9.5	–	4.8
<i>Tithonia</i>	16.4	21.4	30.9	11.9	1.8	–
<i>Pigeon pea</i>	7.3	21.4	21.8	9.6	5.5	2.4

Table 3. Logit model Results of factors affecting adoption of legume cover crops

Variables	Coefficients	Standard error	T. Ratio
Group membership	1.67	0.80	2.08**
Gender 1	0.20	0.70	0.03
Sub-county location	0.11	0.72	0.15
Age	-0.76	0.80	-0.96
Primary education	-1.39	1.03	-1.35
Secondary education	-1.65	1.00	1.65*
Contact with extension agent regular	3.65	1.52	2.57***
Occasional visit	2.28	1.01	2.26**
Low conflict	-2.87	1.21	-2.37
Average conflict	-0.80	1.17	-0.68
Low co-operation	1.40	1.11	2.26**
Average	1.82	0.84	2.18
Low information sharing	-1.12	1.02	-1.10
Average information sharing	1.84	0.97	1.90*
Size of land	-1.38	2.06	-0.67
Constant	-1.38	2.06	-0.67

*** = Significant at 1% level; ** = Significant at 5%; * = significant at 10%; log likelihood -30.47; Chi square 0.0037***; Probability of right prediction 41.7%

in Kabale and Kisoro, has been hampered by conflicts and jealousy which affect participation of some farmers in experimental activities.

Conclusion

Adoption of SFMT in Uganda is vital for restoring soil fertility, so as to increase agricultural productivity. Among some of the technologies that farmers in Tororo use to improve soil fertility are legume cover crops and shrubs such as *Mucuna*, *Calliandra*, *Leuceana*, *Crotalaria*, *Canavalia*, *Lab-lab*, *Tephrosia*, *Sesbania*, and others. Some farmers have been able to adopt these technologies due to their favourable characteristics, for example, low initial capital outlay, low labour requirements, ease of suppress weeds, drought resistance, conservation of moisture. In addition, INSPIRE Project through its activities has promoted these technologies. It established that one of the factors in the adoption of these technologies in Tororo district is the social capital existing in farmers groups. Social capital manifested itself in farmers' cooperation, information sharing, and exchange of technologies.

It is therefore recommended that strengthening local organisations, social institutions and other social structural factors would increase adoption of these technologies. Besides this, increasing extension services

would play a significant part in enhancing adoption of technologies.

Acknowledgements

The authors wish to acknowledge with gratitude, contributions from the Rockefeller Foundation for funding this research through the INSPIRE project; TSBF-CIAT, ICRAF, staff of Africa 2000 Network, Makerere University, and farmer participants from Tororo district.

References

- Adams M.E. 1988. *Agricultural Extension in Developing Countries*, Longman, Essex.
- Adesina A.A. and Zinnah M.M. 1993. Technology characteristics, farmers' perceptions and adoption decisions: A. Tobit model application in Sierra Leone. *Agric. Econ.* 9: 297-311.
- Bohrnstedt G.W. and Knoke D. 1988. *Statistics for Social Data Analysis* (2nd Ed). Itasca, USA: Pedlock Publishers.
- Bojo J. 1994. The cost of the land degradation from natural perspective: an assessment of African evidence, paper presented at the eight international soil conservation conference, New Delhi, India, December 4-8, 1994.
- Coleman J. 1988. Social Capital in creation of human capital. *American journal of sociology* 94: 595-5120.
- Enyong L.A., Debrah S.K. and Bationo A. 1999. Farmers perceptions and attitudes towards introduced soil-fertility enhancing technologies in western Africa. *Nutrient cycling in Agroecosystems* 53:1777-a87, 1999. Kluwer Academic publishers, Netherlands.

- Esilaba A., Byalebeka J.B., Nakiganda A., Mubiru S., Ssenyange D., Delve R., David S., Mbalule M., Miiro R., Nalukenge G. 2001. *Improving Integrated Management Practices on Smallscale Farmers in Africa*. Makerere University, Kampala, Uganda. Unpublished.
- Gujarati. N.D. (1988). *Basic econometrics* (2nd edn). New York: McGraw- Hill Book Company.
- Hazell P., Anna K., McCulloch and Meinzen R.D. 1997. *Peoperty Rights, collective action and technology adoption. A conceptual framework*. Baltimore: Johns Hopkins University Press.
- Isham J. 2000. *The effect of Social capital on technology adoption. Evidence from Rural Tanzania* Department of economics and the program in Environmental studies Middlebury College, conference on opportunities in Africa: Micro-evidence on firms and Households. April 19th 10th.
- Isham, Jonathan 2002. *The effect of Social capital on Fertilizer adoption Evidence from Rural Tanzania*. Middlebury College economics discussion paper No. 02–25 <http://www.middlebury.edu/~econ>.
- Miiro R., Kabuye F., Jama B.A., Delve R., Musenero E., Zake J.Y.K., Nkwine C., Kakinda M.J. and Onyango O. 2000. *Farmer Evaluation of the Integrated Nutrient Management Technologies. Initial Development of the INSPIRE Project in Tororo District, Eastern Uganda*. Makerere University Kampala, Uganda. Unpublished.
- Putnam Robert D. 1993. *Making Democracy Work*. Princeton, NJ: Princeton University Press.
- Rogers M.E. 1983. *Diffusion Of Innovations* 3rd edn. The Free Press, New York.
- Sanchez P., Izac A.M., Buresh R., Sshepherd K., Soules M., Mokwonye A.U., Palm C. and Ndeer C. 1997. *Soil fertility replenishment in Africa as an investment in Natural Resource Capital*. In replenishing soil fertility in Africa, R. Buresh and P. Sanchez eds. SSSA special publication 51 Madison w1: soil science society of America (SSSA).
- Sanginga P.C. 1998. *Adoption and social impact Assessment of Agricultural technologies. The case of soybean in Benve State, Nigeria*. Doctorial dissertation University of Ibadan.
- Semana A.R. 1998. *The Impact of On-farm Trials and Demonstrations on Farmers in Southern Western Uganda*. Unpublished Ph.D. Thesis, Makerere University, Uganda.
- Stoorvogel J. and Smaling E. 1990. *Assessment of soil nutrient depletion in Sub-Saharan Africa: 1983–2000*. Report No. 28, Vol. 1–4, Winand starring Center, Wageningen, Netherlands.
- Thomas D. and Sumberg J. 1995. *A review of the evaluation and use of tropical Forage legumes in Sub-Saharan Africa*. *Agriculture, Ecosystems and the Environment* 54: 151–163.
- Tumwegamire & Mwebesa 1999. *Farmer Partoicipatory Approaches in Sustainable Soil Fertility Improvement and Maintenance: CARE–DTC’S Experience*. pp 351–354. Proceeding of the 17th Conference 6–10 Sept. 1999, Kampala.
- Waata F. Jama B. and Delve R. 2002. *Integrated soil productivity initiative through Research and Education (INSPIRE): A collaborative effect to improve livelihoods in Tororo District, Uganda*. Africa 2000 Network, Tororo, Uganda. 13p.
- Wortmann C.S. and Kaizzi C.K. 1988. *Nutrient Balances and Expected Effects of Alternative Practices in Farming Systems of Uganda*. *Agriculture, Ecosystems and Environment* 71: 115–129.
- Young A. 1994. *Agro-forestry for Soil Conservation*. Wallingford, UK: C.A.B. International.
- Zake J.Y.K., Nkiine C. and Bwamiki D. 1998. *Advances in soil management for the coffee/banana farming system in Uganda*. pp. 158–168. In proceedings of the 17th An. Gen. Meeting of Soil Sci. of East Africa, Kampala, Uganda.

Adoption of Leguminous Trees/Shrubs, Compost and Farmyard Manure (FYM) As Alternatives to Improving Soil Fertility in Trans Nzoia District-Kenya

Nekesa. A.O.¹, Okalebo, J.R.¹, Kimetto, S.²

¹Department of Soil science Moi University, P.O. Box 1125, Eldoret, Kenya; ²VI Agroforestry Project, Kitale, P.O. Box 2006, Kitale, Kenya.

Abstract

Trans Nzoia district in Western Region-Kenya is characterized by highly weathered acidic and infertile soils. This is as a result of continuous cropping of the soil with limited or no replenishment of soil nutrients. In this region, high input and transport costs for agrochemicals make the use of inorganic fertilizers on staple foods uneconomical for most farmers, hence each year's production is less and poorer compared to the previous. Small-scale farmers have used several methods in trying to curb the problem of soil infertility and the high cost of inorganic fertilizers. These include fallowing, use of fertilizers, use of organic manures (Farmyard manure, compost) use of leguminous trees and even systems that incorporate all the above mentioned inputs. This paper focuses on the success stories of farmers who have used organic manures (FYM and compost) and leguminous trees as alternatives to improving soil fertility and have achieved amazing results. It targets the importance of these sources of nutrients and especially the aspect of affordability to the poor small-scale farmers.

The survey on soil fertility issues was conducted in Kaplamai division of Transnzoia district, using a semi structured questionnaire and direct observations. Farmers were selected using a cluster-sampling scheme. A sample of 20 contact farmers was randomly selected. Two neighbours of each contact farmer were further selected, one adjoining the contact farmer and another at a minimum distance of a kilometre. Results showed that the farmers using FYM and compost together with leguminous trees reported better yields with improved soil structure. Those who incorporated all these systems reported less input of fertilizer yearly with high output. Inorganic fertilizers alone caused soil acidity and this input had to be increased each year

Key words: Food production, leguminous trees, organic manures, soil fertility

Introduction

In order to increase food production to meet the demand by the ever increasing population, replenishment of soil fertility, especially N and P is necessary. Low per capita income and limited credit facilities restrict the use of farm inputs to maintain and improve soil fertility, increasing the dependency of farmers on internal farm resources and natural biological processes (Sisworo et al., 1990). Under these circumstances, farmers turn to leguminous trees (LT), farmyard manures (FYM)

and compost to supply them with these nutrients for their soils. Sunburn Field in the US, that has been in continuous crop production since 1888 and 24 other long-term experiments show that crop production can be sustained with appropriate crop rotations, residual management and maintenance of soil fertility (Mitchell et al., 1991).

Legumes supply food, fodder, shade, fuel and green manure, which is an important aspect of N replenishment. As forages, legumes can be grazed or used in cut and carry systems. Legume green manures offer

a low cost opportunity for maintaining soil fertility by mainly improving nitrogen supply to the soil. This can be achieved if the species chosen as green manure crops are compatible with climatic conditions and soil characteristics of the area. Multipurpose agroforestry species have shown the potential for enhancing the production of both crops and livestock on limited resource farms (Palm et al., 1988). Trials conducted in the mid altitude areas of Uganda have shown that when *Clotolaria ochloresca* green manure is incorporated in the soil it can increase maize grain yield by 39%. Major differences in mineral nitrogen content among the treatments occurred at six leaf stage of maize crop (Fischler et al., 1999).

The effect of legumes on soil fertility enhancement depend on factors such as soil and weather conditions during development and decomposition of the legume, length of the time that the legume is growing, quantity of biomass eventually produced by the legume and the legume species (Lal et al., 1991). Animal manures and compost are beneficial in soils because they can increase the water holding capacity and cation exchange capacity (CEC) (Nandwa, 1995). Manure from livestock is known to supply approximately 30% of the N needs for crop production in the North Eastern USA (Jokela, 1992).

The positive responses of crops to manures have been attributed to (1) The quantity of the manure N already available for the plants, (2) Amount of N that becomes available after mineralization during the growing season, (3) Release and availability of P, K and microelements, and, (4) Improvement in soil structure and permeability (Bocchi and Tano, 1994). Farmyard manures are very important as sources of nutrients, but unfortunately their use is limited due to their low and variable composition and the large quantities needed to provide plant nutrients (Nandwa, 1995).

Composting is considered a way of increasing the use of organic inputs and reducing the adverse effects of insufficiently decomposed boma manure and crop residues which could burn crops and cause problems with pests and diseases (Hilhorst and Muchena, 2000). An experiment carried out in Machakos and Nyeri (districts in Kenya) to compare how maize responded to applications of compost and a combination of boma manure + DAP (16.2 t per ha compost with 17 t per ha boma manure + 57 kg per ha DAP) showed varying results. In Machakos, the compost performed much better than the combination of boma manure + DAP giving a higher maize yield, greater net cash benefits and a better net return on labour. However results in

Nyeri showed the converse with the combination of boma manure + DAP performing better than compost (Hilhorst and Muchena, 2000). In a subsequent study in Machakos, liquid manure was tested as an input for maize. Liquid manure is prepared by mixing fresh animal droppings with water. It has a high N-content and is applied to soil near the plant roots when the crop is knee high. It was tried in combination with compost and compared with single and double doses of compost on its own. Yields and net cash benefits were highest for the combination of compost with liquid manure, although the return to labour for these treatments was the lowest of the three treatments tested (Onduru et al., 1998).

While these methods are viewed as alternatives to use of inorganic fertilizers, they also have their drawbacks. Farmers for example prefer boma (Farmyard manure) production to composting because producing boma manure that includes the incorporation of crop residues and bedding is an easier alternative (Hilhorst and Muchena, 2000). Usually there is lack of knowledge or awareness of the soil fertility value of green manures and more so the decomposition characteristics of many manures are not too well known (Lathwell, 1990).

The objectives of the study were to (1) Determine sources of nutrients for crop production in the district, (2) Compare the economic returns from the use of compost manure, farmyard manure, leguminous trees and inorganic fertilizers in replenishing soil fertility, (3) Determine the effect of using Leguminous trees, farmyard manure and compost in combination on yield in comparison with use of inorganic fertilizers, and, (4) Determine the effect of farm size on use of compost, farmyard manure and leguminous trees on replenishing soil fertility.

Methodology

The survey was conducted in Kaplamai Division of Trans Nzoia District, Kenya. Transzoia District lies between Latitudes 0°52' and 1°18' North of the Equator and Longitude 34°38' East, and covers an area of 2,467 sq. Km, which represents 0.42% of the whole Republic and 1.4% of Rift Valley Province. The population is estimated at 645,170 people with 321,470 males and 323,700 females (GoK, 2000).

The district has a highland equatorial rainforest type of climate but is slightly influenced by relief rainfall around Mt. Elgon, which rises 4313 metres above the sea level and Cherangani hills, which elevate at 3371 metres above sea level. Rainfall is well distributed

throughout the year with average annual precipitation of 1290 mm. Long rains are experienced in the month of April to June while short rains fall in the month of July to October. The average temperature is 18.6° C but usually temperatures vary between 10° C to 37° C. These temperatures and rainfall patterns qualify Transzoia district as having a very favourable climate for both intensive agriculture and livestock production.

Several projects funded by international donors, most of which are involved in replenishing soil fertility, are operational in this district. These include VI Agroforestry Project, Kitale, CEEDCO (Community Empowerment and Enterprise Development through Cooperatives), CENART (Community Empowerment and National Agricultural Research Technology) to name just a few. The survey focused on the activities implemented by VI Agroforestry Project. VI Agroforestry Project Kitale, Kenya, is one of the East Africa projects funded by the Foundation Vi Planterar trad. The Foundation is supported by the Vi magazine, which is the voice of the Swedish Consumer Association (Vi is the Swedish word for "WE"). Funds for the Foundation are raised by private donations and from Swedish government via the Swedish International Development Agency (SIDA). In 1997 the Norwegian Consumer Association and the Norwegian Agency for Development Co-operation (NORAD) started funding the Foundation.

The project's developmental objective is to contribute towards the improvement of the living standards of small-scale farmers and to arrest land degradation. Soil fertility improvement, one of the project activities in meeting their developmental objective, is through application of compost materials (organic matter from trees/crop residues) and promotion of short term fallows.

The survey was conducted using a semi structured questionnaire and direct observations. Farmers were selected using a clustered sampling scheme. A sample of 20 contact farmers was randomly selected. Farmers targeted were small scale case (farmers owning between 0.04 and 2 ha). Most farmers owned between 0.4 and 0.8 ha with very few individuals owning 2 ha. Two neighbours of each contact farmer were further selected, one adjoining the contact farmer and another at a minimum distance of one kilometre hence bringing total number of farmers sampled to 60. Questionnaires were filled and any other additional information obtained from direct observations was recorded. Data was analyzed using

Microsoft Excel and SPSS Software. Treatment means were subjected to standard error deviation (SED) and least significance difference (LSD) estimates for comparison.

Results and discussions

According to the results, planting of leguminous trees as a strategy to improve soil fertility was inversely proportional to the land size. Apparently farmers with smaller landsize planted trees more than farmers with larger pieces of land. They also diversified their farming activities while the large scale farmers preferred monocrops. Leguminous trees planted include *Sesbania sesban*, *Calliandram calothyrsus*, *Luceana lucocephala* and *Albizia spp* and shrubs such as *Clotolaria*, *Tithonia* and *Tephrosia*.

The results also showed that there was a significant difference ($p = 0.05$) between prices of organics and inorganics. Organics were obtained at a very low cost (Figure 1) usually home made or obtained from their neighbours or friends. There was no significant difference in prices between the organics themselves (leguminous trees, FYM and compost) and usually farmers used them in combination with each other. Some farmers supplemented their organics, usually compost, with lower rates of fertilizers and according to their observation this gave higher yields.

From the response of farmers (Table 1), it can be clearly seen that compost, LT and FYM were favoured in terms of improving soil structure (farmers cited improvement of soil structure as a soil being black, soft and crumbly), high yields and low costs incurred during application, except for ease of incorporation. Farmers complained that although fertilizers were expensive, it was easier to apply them as compared to the organics where application and incorporation into the soil was very laborious. Farmers also observed that continuous use of fertilizers for a long period of time caused soil acidity. This was highlighted when farmers described the appearance of crops that were planted in farms that had continuously been cultivated with inorganics as being stunted. They described the soil as having a lot of 'chumvi' - a Swahili word meaning salt- and consequently fertilizer had to be increased yearly to achieve yields similar to the previous harvests.

According to extensionists, composting is done by first digging a pit 1.5 × 2.0 m wide which would include: dry vegetation material, green vegetation material, ordinary and 0.3 depth or a convenient depth

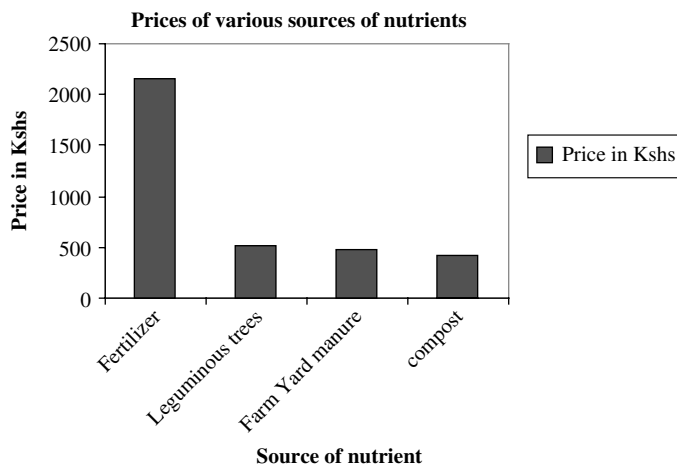

Figure 1. Prices in Kshs per 50 kg of sources of nutrients as evaluated by farmers.

Table 1. Farmers evaluation on the importance of the source of nutrients under study

Nutrient source	Improving soil fertility (%)	High yields (%)	Low costs incurred (%)	Ease of incorporation (%)	Acidity (%)
Fertilizer	0	10.90	5.38	50.00	77.75
Compost	15	9.50	14.62	12.50	7.71
Leguminous trees (LT)	30	17.50	44.25	8.70	0
Farm Yard Manure (FYM)	10	12.25	14.75	10.30	12.29
LT/FYM	22.5	18.55	11.99	12.30	1.75
Comp/LT/FYM	27.5	31.30	9.01	6.40	0.2
Total percentage	100	100	100	100	100

*The figures (percentages) represent the response of farmers when asked to list the importance of sources of nutrients under study.

and filling it with layers of organic material, black soil from the garden, animal droppings and ordinary ash. These are watered regularly and turned twice during the decomposition process. A pit this size can produce one tonne of organic fertilizer or compost (Hilhorst and Muchena, 2000). A total of Fifty percent of farmers interviewed were positive about composting citing soil structure improvement (black, soft and crumbly), high yields, low costs incurred as some of the benefits derived from the use of compost. The farmers also said that the compost carried less risk of burning crops and fewer infestations of pests and diseases (Hamilton, 1997; Onduru et al., 1998). Twenty percent were generally negative saying that digging the pits, collecting plant materials and then watering them made it too labour intensive for them. They also said that obtaining sufficient organic materials for the technology was difficult and they could not make enough compost for the whole season. Problems such as limited water supply especially during the

dry season when they were advised to do the composting, transportation of ready compost to the farm, small numbers of livestock were also cited as major constraints to composting.

Composting

How to make compost

Apart from being an accessible technology to small scale farmers, compost making focusses on the utilisation of bulky maize stover which is difficult to dispose after harvests. Hence a detailed compost making method is described.

Farmers working with VI Agroforestry Project, Kitale have a standard way of making compost. Interviews with 20 farmers gave a more or less the same procedure of making compost that has been adopted by small-scale farmers under study. The procedure is described below.

Materials needed include;

100 parts of dry vegetation material, 50 parts of green vegetation material (particularly leaves of high leguminous trees), seven parts of ordinary black top soil from the garden, six parts of animal droppings, ordinary wood ash; just enough for sprinkling and several jugs of water.

The procedure includes selecting a sheltered place with shade, not too far from the field where the compost is to be used. An area of 1.5×2 m and a depth of 0.3 m or a convenient depth depending on the available materials, is dug out. The depth of 0.3–0.5 m gives 1 tonne of compost. The soil dug out is used in the process and therefore it is kept one side alongside the trench. A first bottom layer of rough dry material such as maize stalks, is laid down with materials that are too long being chopped into smaller pieces. This layer is about 30 cm thick.

The next layer consists of dry compound/hedge grass and or leaves. Some water is sprinkled to make the dry materials moist but not wet. This layer should be 10 cm thick. A third layer of animal droppings or old compost or biogas slurry is put on top of the second layer and this is about 10 cm thick. Some topsoil is then sprinkled to generally cover the material. A layer of green leaves from high protein leguminous trees like *Calliandra*, *Luceana*, *Sesbania*, *Albizia* etc follows this. This layer should be 15–20 cm thick. Wood ashes and topsoil are then sprinkled on top. The whole pile is then watered well using a watering can or any other container. The process is then repeated severally until the pile is built up to 1.5 m high. A well-made pile has vertical sides and a flat top. To complete the pile, it is covered by 10 cm of topsoil, which is then finally covered by dry vegetation. A long, sharp pointed stick is driven into the pile in a slanting manner. This is called a thermometer. After 3–4 days decomposition in the pile will have began. To confirm this, the thermometer is pulled out from the pile. It is usually warm and if done early in the morning it is seen to let off vapour.

The thermometer helps check the condition of the pile from time to time. It helps to show when the pile is moist or dry. Sometimes the thermometer is white, a fungus called fire fang, which destroys the compost when the pile becomes dry inside causes this. The pile should be watered occasionally say on every other day depending on the weather conditions. The pile should be turned after three weeks and one should avoid adding any fresh material during turning except watering or sprinkling soil where the fire fang has developed. While

turning, the bottom part of the pile becomes the new top part of the new pile. This is necessary because the rotting at the bottom is slower than at the top. After three weeks the pile is turned again making sure that it remains moist. When the pile has been well taken care of, the compost is ready in two weeks after second turning. By this time the compost has a smell of fresh earth, is cool and one cannot distinguish any original materials except some woody twigs and stalks, which take long to rot. If the planting season is far away, the pile is left where it is and kept well covered and moist. A shade can be erected over it.

Eighty percent of farmers interviewed said leguminous trees were beneficial to their crops. Some of the benefits cited were inhibition of weeds, improving soil structure (soil becomes black, soft and crumbly). They also reported high yields especially when used in combination with compost and farmyard manure. According to farmers in Transzoia district, use of leguminous trees for improving soil fertility is cost effective because it only requires seed which is relatively cheap and can be obtained by almost all farmers in this region, since seeds are supplied to them by VI Agroforestry Project or those who directly obtain seeds from their trees share them out with their neighbours, and for those who buy them, their price is relatively low.

Stute and Posner (1995) observed that since various costs of the legume rotations are lower than continuous cropping (i.e., legume seed is cheaper than N fertilizer), gross margins of the legume rotation are generally similar to continuous maize grown with 180 Kg N/ha. In this study, the average yield of maize following a legume was 116% higher.

Farmers in Transzoia district differ in their management of the leguminous trees biomass. A larger percentage of farmers interviewed plough in the legume while it is still green and growing. In this practice, decomposition is rapid and more N is available (Woomer and Swift, 1994). Some just cut the biomass and leave it to decompose on the soil surface. However without tillage, surface applied legume residues decomposed more slowly than incorporated residues during the first four weeks. According to Burle et al. (1992) such management leads to nitrogen loss through the volatilisation of ammonia.

Quality of farmyard manure is influenced by the source (e.g., cattle, sheep, goat, pig, and poultry), storage, method of application and handling conditions. Usually the farmers collected the cattle manure in a heap and left it for some time to decompose. According to farmers, undecomposed FYM (raw) has higher risk

of burning the crop especially when applied on the surface around the crop. Farmers interviewed stressed the importance of handling the FYM saying that it should be stored in a well aerated enclosure, preferably in a shed to allow decomposition of organic matter and to reduce nutrient losses. They also noted the importance of the shade saying that if FYM was rained on, nutrients get lost through leaching and erosion. Also keeping it away from direct sunlight reduces loss through volatilisation (Muriuki and Qureshi, 2001). A larger number of farmers interviewed said they complemented the FYM used on their farms with compost or leguminous trees because the small number of cattle does not allow for large quantities of manure adequate for their crops. Asked if he would rather use inorganic fertiliser, one farmer (Mr. David Kemboi) refused vehemently saying he would rather take half the year preparing compost and FYM than go back to using inorganics that he had previously been working with. He noted that inorganic fertilisers were expensive and the need to increase their amounts doubled every year.

Conclusions

Due to the realisation that their soils are losing fertility with time, farmers in this region have used various farm practices with the purpose of maintaining or improving soil fertility. By farmers' assessments, some of these practices are more effective than others. Having worked with organics for a long time, farmers small-scale in Transzoia prefer application of organic manures (LT, FYM and compost) either alone or in combination with low rates of inorganic fertilizers. For LT, farmers expressed interest in legumes that had other uses in addition to soil fertility improvement. They singled out human food and livestock feed as important characteristics because of food security and shortage of livestock feeds.

Acknowledgements

The authors are grateful to all the farmers interviewed and their contribution in observations that were with a lot of enthusiasm. We also give thanks to all the extension officers and the zone manager, Margaret Korkech of Kaplamai Zone who volunteered to collect the data without any payment and to Carol Mwongera who assisted in data analysis. Our thanks also go to the Management of VI Agroforestry Project in Kitale

who supported the writing of this paper. Finally we are grateful to TSBF for selecting this paper for presentation and for funding the trip to Cameroon for the presentation.

References

- Bocchi S. and Tano F. 1994. Effects of cattle manure and components of pig slurry on maize growth and production. *Eur. J. Agron.* 3(3): 235–241.
- Burle M.L., Suhert A.R., Poreira J., Resck D.V.S., Peres J. R. R., Cravo, M.S., Bowen W., Bouldin D.R. and Lathwell D. J. 1992. *Legume green manures, Dry season survival and the effect on succeeding maize crops*. Soil management CRSP Bulletin 92–104. North Carolina State University, Raleigh. 35p.
- Fischler M., Wortman C.S. and Feil B. 1999. *Chlotolaria ochrolesca as a green manure in maize bean cropping system in Uganda*. Field crops Research 61: 97–107.
- Government of Kenya 2000. *Transzoia, District Development Plan, 1997–2000*. Government printer, Nairobi.
- Hamilton P. 1997. Goodbye to hunger: the adoption and diffusion and impacts of conservation farming practises in rural Kenya. Association for better land husbandry (ABLH), Nairobi.
- Hilhorst T. and Muchena F. M. (Eds). 2000. *Nutrients on the move—Soil fertility dynamics in African farming systems*. International Institute for Environment and Development, London.
- Jokela W. C. 1992. Nitrogen fertilizer and dairy manure effects on corn yield and soil nitrates. *Soil Sci. Soc. Am. J.* 56: 148–154.
- Lal R., Regnier E., Eckert D.J. Edwards W.M. and Hammond R. 1991. Expectations of cover crops for sustainable agriculture. In: *W.L Hargrove (ed). Cover crops for clean water*. Soil and water conservation society.
- Lathwell D.J. 1990. *Legume green manures: Principles of management based on recent research*. Tropsoils Bulletin No. 90–01 North Carolina State University, U.S.A.
- Mitchell C.C., Westerman R.L., Brown J.R. and Peck T.R. 1991. Overview of long term agronomic research. *Agron. J.* 83(1): 24–25.
- Muriuki A.W. and Qureshi J.N. 2001. *Fertiliser use manual*. Kenya agricultural Research Institute, Nairobi.
- Nandwa S.M. 1995. Synchronisation between soil N mineralization and maize uptake through management of maize stover. In: *Woomer P.L. and Swift M.J. (eds). The biology and fertility of tropical soil*. Instaprint Limited, Nairobi, Kenya. Pp 6–7.
- Onduru D. D., Nandwa S. M. and Gachini G.N. 1998. Experiences in participatory diagnosis of soil nutrient management in Kenya. *Managing Africa's soils, Drylands programmes IIED*, London.
- Palm O., Weerakoon W.L., De Silva M.A.P. and Rosswall T. 1988. *Nitrogen mineralization of Sesbania sesban used as green manure for low land rice in Sri Lanka*. Plant and Soil 108: 201–209.
- Sisworo, W. H., Mitrosuhardjo, M. Rasjid, W., and Meyers. 1990. *The relative roles of N fixation, fertilizer, crop residues and soil in supplying N in multipurpose cropping systems in a humid, tropical upland cropping system*. Plant and Soil 121: 73–82.
- Stute J. and Posner J.L. 1995. Legume cover crops as a nitrogen source for corn in an Oat rotation. *J. Prod. Agric.* 8(3): 385–390
- Woomer P.L. and Swift M.J. 1994. *The biological management of tropical soil fertility*. John Wiley and sons, New York. 243p.

Participatory Diagnosis in the Eastern Drylands of Kenya: Are Farmers aware of their Soil Fertility Status?

Kimiti J.M.^{*1}, Esilaba A.O.², Vanlauwe B.³ and Bationo A.³

¹Kenya Forestry Research Institute, P.O. Box 20412, Nairobi Kenya; Tel: +254-721-473-341 & +254-733-881-582, Fax: +254-66-32844; Email: jmkimiti@yahoo.com; ²Kenya agricultural Research Institute, P.O. Box 57811-00200, Nairobi, Kenya, ³TSBF (CIAT) C/O ICRAF, United Nations Avenue, Gigiri. P.O. Box 30677, Nairobi, Kenya

Abstract

A participatory diagnosis (PD) was carried out in Makueni District, eastern Kenya, with a view of identifying farmer awareness on soil fertility status so as to identify gaps for research on soil fertility improvement. The results indicate that farmers are aware of soil types, soil characteristics soil, soil fertility status and soil distribution of different soil types in their villages. In addition, the farmers are aware of declining soil fertility, which they attributed to soil erosion, continuous cropping, poor methods of cultivation, and inadequate farm inputs. The farmers use farmyard manure to improve soil fertility and are aware of the quality of different manures used in their farms. The types of farmyard manures as ranked by farmers in decreasing quality are poultry manure > goat manure > cattle manure. However it was revealed that cattle manure is commonly used because it is readily available though not adequate. Crop residues, especially those of grain legumes, are also used for soil fertility improvement. In this paper the results of farmer participation research meetings with emphasis on soil fertility management in eastern Kenya are discussed

Key words: Crop residues, eastern Kenya, farmer participatory research, farmyard manure and soil fertility

Introduction

Continuous cropping, removal of crop residues to feed animals and overgrazing between cropping seasons with little or no external inputs have reduced the productive capacity of arable lands and thus threaten the sustainability of food production systems in Sub-Saharan Africa (Stoorvogel et al., 1993). In Kenya, decline in crop yields has been a major problem-facing smallholder farmers (Mathuva et al., 1996). This is attributed to high costs of inputs that make the use of inorganic fertilizers on staple food crops uneconomical for most smallholder farmers (Heinsey and Mwangi, 1996; Jama et al., 1997). Use of organic inputs as an external source of soil nutrients is a logical cheap alternative to expensive fertilizers for smallholder farmers. However, organic inputs are low in nutrient

concentration to inorganic fertilizers (Sanchez et al., 1997). Despite the fact that organic inputs are low in nutrients (Giller et al., 1997), cattle manure is an integral component of soil fertility management, and manure application is one of the most commonly used and effective way of soil fertility improvement for crop production in Africa. For example, in the semi-arid areas of eastern Kenya where nitrogen and phosphorus limit crop production, manure has been used to enhance soil fertility and crop production (Gibberd, 1995; Ikombo, 1984; Kihanda et al., 2004).

This paper discusses the results of a participatory diagnosis in Makueni district in semi-arid eastern Kenya, which included farmer awareness of soil distribution within their villages, soil types and characteristics, soil fertility decline, associated problems and causes and attempts being made by farmers to address

soil fertility decline in two sites with contrasting climate and land sizes.

Materials and methods

A reconnaissance survey was done in two divisions of Makueni district, Mbitini and Nguu, in July 2003. The aim of the survey was to select sites for on-farm participatory research. Four sub-locations (sites) were selected which included Kavuthu and Matiku in Mbitini division, and Yikivumbu and Ndunguni in Nguu division. Criteria for site selection included accessibility during rain season, rainfall differences and soil differences. The extension officers from the Ministry of Agriculture assisted in site selection by provision of secondary information and guidance during the site visits. After the sites were selected, visits were made to the administrative offices in the selected sub-locations and meetings were held with relevant administrators (chiefs and the assistant chiefs). The administrators were briefed on the purpose of the visits and objectives of the project. During these visits dates for community meetings were agreed upon. The administrators and the extension officers mobilized the communities for the proposed meetings through posters and announcements in public meetings (locally called 'barazas'). During community meetings the chief of each sub-location coordinated the meetings. The role of the extension officers during the meetings was to brief the farmers on the purpose of the meetings and of the daily programme. Farmers attending the meetings were requested to divide themselves into small groups of at least 20 persons, depending on the number community members present, so as to allow for participatory discussions among the farmers. Each group was given a specific task to discuss, such as community resource map drawing, soil fertility and crop growing, and was expected to give results at a plenary meeting.

In this paper only result obtained from two sites, Ndunguni sub-location and Kavuthu sub-location are discussed because both sites adequately represent the two sites selected in each division. Kavuthu sub-location is located at Mbitini division and the sub-location is made up of three villages, Kavuthu, Ngomano and Tumbuni. The main characteristic of this are that it lies on the windward side of Kilungu hills and is wetter than Ndunguni sub-location, receiving between 700 to 1000 mm per year, with most of the rain falling in the short rains of December. It is

densely populated compared to Ndunguni and farming and animal keeping are practiced. Ndunguni sub-location on the other hand is made up of 6 villages; Kyuasini, Yumbuni, Ndivuni, Kwavundi, Mbulutini and Kalovya. It lies to the east of Kavuthu location and is drier and most people have large farm sizes. Farming and livestock keeping are practiced at Ndunguni and due to large land sizes most people keep large herds of cattle, sheep and goats, compared to those of Kavuthu, as a security against unreliable rainfall in the area.

Results and discussion

Village resource maps

The objectives of the village resource maps were to determine the distribution of all soil types and document the characteristics of each soil type in the selected sites. Fertility status of each soil type was also documented. Participants in map drawing at Ndunguni sub-location consisted of 12 women and 5 men whereas those of Kavuthu sub-location composed of 3 women and 7 men. In both sites the participants first selected a flat ground and then selected one person to do the actual map drawing under their instructions. The selected person under the instructions of the participating group members used a stick to draw all the villages and important features within each sub-location. After the map was drawn the members marked important features such as village boundaries, rivers, social places with locally found materials such as sand, cow dung and wood ash. The exercise took a whole morning, about 4 hours in both sites because the community members had to discuss and agree on all features included in the map.

In both sub-locations, the inhabitants identified three major soil types, black cotton soils, red soils and sandy soils. However, a detailed description of the soils varied across the sites. For example, at Ndunguni sub-location both the black and red soils were sub-divided into two groups, each group having its own distinguishing characteristics. The data further revealed that red soils are dominant in both sites occupying 60% of Ndunguni and 40% of Kavuthu Sub-location (Table 1). It was observed that gender participation in the groups varied within site as at Ndunguni sub-location, men appeared to know more than the women who were the majority, whereas at Kavuthu sub-location women were more informed on the soil distribution and soil types and

Table 1. Soil characterization by farmers in Kavuthu and Ndunguni sub-locations

Soil Types/Sites	Kavuthu sub-blocation	Percent distribution	Ndunguni sub-location	Percent distribution
Black cotton Soils	<ul style="list-style-type: none"> – Black in colour – Waterlogged in rain season – Has high water holding capacity – Cracks during the dry weather – Sticky when wet 	27	a) Cracking type <ul style="list-style-type: none"> – Black in colour – Not fertile – Indicated by presence of <i>Acacia depanarolubium</i> – Cracks when dry – Sticky when wet b) Non cracking cotton soil <ul style="list-style-type: none"> – Good Moisture retainer – Very fertile – Easily water-logged during heavy rains 	10
Red Soils	<ul style="list-style-type: none"> – Red in colour – Good drainage – Medium water holding capacity – Fertile 	40	a) Hard red soils (Kitune Kyumu) <ul style="list-style-type: none"> – Hard to work on when dry – Not fertile b) Soft red soils (Itumbekethe) <ul style="list-style-type: none"> – Loosely packed grains “soft: – Easily eroded by wind – Good moisture retention – Fertile 	60
Sandy Soils	<ul style="list-style-type: none"> – Whitish in colour – Very well drained – Low water holding capacity – Large grains – Poor in nutrients – Quickly dried by sun 	33	<ul style="list-style-type: none"> – ‘Whitish’ sometimes grayish in colour – Hard to work when dry – Easily wetted – Poor moisture – Poor moisture retention 	30

characteristics compared to their male counterparts who easily agreed with their opinions. The farmers at Kavuthu knew in detail the distribution of each soil type in the three villages (Tumbuni, Ngomano and Kavuthu) of the sub-location (Table 2). However, farmers from Ndunguni sub-location, which have 6 villages (Kyuasini, Yumbuni, Ndivuni, Kwavundi, Mbulutini and Kalovya) described the soil types and their characteristics but not in much detail as in Kavuthu probably because of the sub-location occupies a large area which complicates soil classification.

Relationship between wealth and soil fertility management

Wealth indicators

In an attempt to understand the relationship between soil fertility decline and access to resources, the participating community members did analysis of wealth indicators and wealth classes. Wealth indicators were recorded and analyzed in each site (Table 3). In addition farmers identified three wealth classes in the two study sites.

Table 2. Soil distribution across villages of Kavuthu sub-Location

Village	Black cotton soils (%)	Red soils (%)	Sandy soils (%)	Total (%)
Tumbuni	15	60	25	100
Ngomano	5	45	50	100
Kavuthu	60	15	25	100

Table 3. Wealth indicators and rank in Kavuthu and Ndunguni sub-locations

Item	Wealth indicator	Community Ranking	
		Kavuthu Sub-location	Ndunguni Sub-location
1	Livestock size	7	3
2	Land size	3	2
3	Family size	12	8
4	Good business	4	5
5	Good crop yield	8	6
6	Good house	9	4
7	Vehicle(s) ownership	5	1
8	Education	1	9
9	Good job/ employment	2	7
10	Plots in urban centres	6	—
11	Good planner	11	—
12	Living near river	10	—

According to Ndunguni farmers, ownership of vehicle(s), land size and livestock are top three wealth indicators in the sub-location (Table 3). This is explained by the fact that Ndunguni sub-location is located in Nguu division, which is one of the remotest parts of Makueni district. The area has poor road network, is one of the driest parts of the district, and is prone to frequent droughts and famines. In addition majority of the inhabitants are poor subsistent farmers growing maize, sorghum, cassava, beans, pigeon pea and cowpea mainly for consumption. So, a moving vehicle is only associated with the rich. Also most farmers in the area keep livestock, which include goats, cattle and sheep, and some donkeys, as a source of livelihood. So, the size of livestock herd determines how well a farmer lives in the sub-location. As such livestock herd size is a very important wealth indicator in Ndunguni sub-location. In Ndunguni, livestock keeping requires land and the number of animals kept is proportional to the amount of land available. So farmers with big land parcels keep many livestock heads compared to farmers with small land units. The above discussion explains why vehicle ownership, land size

and livestock herd size tops the priority list of wealth indicators in Ndunguni sub-location (Table 3).

In Kavuthu, education, good job and land size are the top three wealth indicators (Table 3). Education according to the farmers is not necessarily that the farmer must be educated but if a farmer educates his/her children beyond secondary level, is regarded by the community as a rich one. If a farmer is educated and has a permanent job is also regarded as a rich one. A good job according to farmers must be a permanent one and a senior post in the government or private sector. Farmers recognize private sector employment more than the government. At Kavuthu sub-location land is a problem and the size of land owned by farmer is a strong indicator of how rich a farmer is. This explains the prioritization of wealth indicators by Kavuthu sub-location farmers (Table 3).

Wealth classes

In this study, it was found that farmers who possess most of the priority wealth indicators such as large parcels of land were also termed rich farmers. It was also noted that as the priority wealth indicators decreased poverty increased giving way to wealth classes such as class 1 (the rich), class 2 (middle rich) and class 3 (the poor). In addition, the intensity of soil fertility management decreased with increasing poverty. This consequently reduces soil fertility and yields obtained by farmers (Table 4).

The main soil fertility improvement interventions are the application of farmyard manure, terracing and fencing. It is clear that the intensity of these soil fertility management options are controlled by wealth of the farmers (Table 4). While manuring and terracing are common in both sites, fencing is only emphasized at Ndunguni sub-location. This is because in this site most farmers keep livestock, which is left to roam about farms during the long dry spells of June to October. The roaming animals eat most of organic matter left on farms after April rains and trample on soils loosening its particles thereby encouraging wind and soil erosion. That is why fencing is a very important wealth indicator at Ndunguni.

Soil fertility decline: causes and indicators

Participating farmers identified soil erosion as the main cause of soil fertility decline in both study sites (Table 5). According to the farmers soil erosion is

Table 4. Wealth classes as identified by the communities

Sub-location	Wealth class and characteristics		
Kavuthu	1	2	3
	Has land more than 10 acres Heavily manures farms and buys manure Have all farms well terraced Have fertile farms and good crop harvest	Has land between 7 and 9 acres Most farms are manured and farmers may buy manure from class 3 farmers Most farms are terraced Most have fertile farms and good crop	Has land size less than 6 acres Rarely manures and sells most of farm manure to class 1 and 2 Terracing is rare Soil infertility is common and rarely no crop harvests.
Ndunguni	1	2	3
	Own more than 15 acres of land Heavily manures farms and buys manure Have well terraced farms Have fertile farms with good harvest Farms are well-fenced	Own 10–15 acres Most farms are manured and farmers may buy manure from class 3 farmers Most farms are terraced Fertile farms are common with good harvest Most farms are fenced	Own less than 10 acres Rarely manures and sells their manure to class 1 and 2 Rarely terraced farms Infertile farms are common with little or no harvest Rarely fences farms

Table 5. Causes and indicators of Soil Fertility Decline

Sub-location	Causes	Indicators
Kavuthu	Soil erosion	Low crop yields
	Little or no inputs	Low soil water retention
	Continuous cropping	Poor crop growth
	Poor farming methods	Plant susceptibility to diseases
	Planting shallow rooted crops	Hardening of soils
	Poor farming methods	
Ndunguni	Use of herbicides	
	Soil erosion	Low crop yields
	Little or no inputs	Reduced plant growth
	Shallow cultivation	Invasion by foreign plants Loose soils

caused by failure to terrace sloppy farms, poor planting methods (hand hoe planting), and overgrazing. Of the three causes of soil erosion, failure to terrace sloppy farms is superior because if farms are well terraced, the other two soil erosion causes are indirectly controlled. Failure to add farm inputs in form of farmyard manure was commonly recognized in both sites as a cause of soil fertility decline implying that the farmers are aware of the benefits of farm inputs. Participating farmers documented that terracing with addition of farmyard manure improves crop yields compared to sole terracing or addition of manure.

In the study sites, farmers have criteria for identifying soil fertility decline in their fields. The farmers in both sites commonly identified low crop yields and poor growth of plants in the affected fields as indicators of soil fertility decline (Table 5). Besides the common soil fertility decline indicators, it is clear that farmers

in both sites have several indicators which tell them of declining soil fertility and which differ from site to another.

Methods of coping with soil fertility decline

Farmers are aware of the declining soil fertility and have taken initiatives to address the problem. Efforts to reduce soil fertility decline was discussed by a group of 5 females and 5 males in Kavuthu sub-location and 5 men and 4 women in Ndunguni sub-location. At Kavuthu, the farmers agreed that animal manure; green manure and inorganic fertilizers (by the rich on vegetables only) are used. The organic manures are broadcasted in the fields during the dry season, without specific measurements. In addition to manure application, soil conservation measures such as terracing,

Table 6. Pairwise ranking of manures in Ndunguni sub-location

Manure Type	Poultry (P)	Sheep/goat(S/G)	Cattle (C)	Rabbits (R)	Donkey (D)	Total Score	Rank
Poultry (P)		P	P	P	P	4	1
Sheep/goat			S/G	S/G	S/G	3	2
Cattle				C	C	2	3
Rabbits					1	4	4
Donkeys (D)						0	5

mulching, crop rotation, ploughing along contours, controlling number of livestock kept, planting of cover crops, planting grass and trees are other interventions used to control soil fertility decline.

Farmers in Ndunguni specified 5 types of manures used as (1) poultry (2) sheep/goat (3) cattle, (4) rabbits and (5) donkeys. They ranked the manures according to their effectiveness in improving crop yields (crop response) and poultry manure was ranked as best manure type, followed by sheep/goat manure, cattle manure, rabbit manure and donkey manure (Table 6). It is important to note that sheep and goats share same enclosures and it is difficult to separate their manures. Cattle manure is commonly used followed by sheep/goat manure due to their availability but donkey manure is never applied in farms because according to the participating farmers it causes tetanus. In this site, Ndunguni, manure may or may not be heaped in animal sheds (to allow for decomposition) before applying in the farms in dry seasons. Manure is only applied to maize, beans, green grams, pigeon pea, and cowpea but not to Dolicos (Lab lab beans), because according to the farmers it enhances vegetative growth thereby reducing grain yields of Dolicos. Manure is applied by either broadcasting, placing in furrows and in planting holes.

Terracing, use of leguminous plant residues, fallowing and crop rotation are other soil fertility management practices used in Ndunguni. Application of manure is done in the dry seasons when it is dusty and is therefore looked as a dirt job and as such is commonly the work of women and primary-going children in the study sites. However, where ox carts exits, some men and children may use the carts to take manure to the farms and keep it in heaps but the work of spreading the manure heaps is still commonly left for women and children.

Conclusion

This study was carried out in drylands of eastern Kenya, Makueni district. Data obtained from two sites by use

of participatory community meetings revealed that, farmers are aware of the soil types, soil distribution in their villages, soil characteristics and soil fertility status. Main soil types identified were black cotton soils, red soils and sandy soils. In addition, farmers are aware of the role played by wealth in soil fertility management, which directly affects soil fertility status and crop yields. It was also revealed that farmers are aware of the causes of soil fertility decline and indicators of the same. In both study sites soil erosion was identified as the main cause of soil fertility decline while decreased crop yields was identified as a common indicator of declining soil fertility. It was further noted that farmers use farmyard manure as the main farm input. Available farmyard manure types used are poultry manure, goat and sheep manure, and cattle manure. Manure quality in decreasing order was ranked as poultry manure > goat/sheep manure > cattle manure. However cattle manure is commonly used because it is readily available. However, the amount of manure applied is usually not quantified and according to the farmers the manure available is not adequate in most households. It was further noted that in both study sites, inorganic fertilizers are not used due to lack of awareness and local beliefs that the fertilizers harden the farms making them highly unproductive. From this study it was found that there exists research gaps in the study sites such as quantification of right amount of manure for use in the sites, studies on integrated nutrient management such as combination of inorganic fertilizers, farmyard manure and crop residues. This forms the way forward of this study.

References

- Gibberd V. 1995. Yield response of field crops to animal manure in semi-arid Kenya. *Tropical Science* 35: 418–426.
- Giller K.E., Cadisch G., Ehaliotis C. and Adams E. 1997. Building soil nitrogen in Africa. In: Buresh R.J., Sanchez P.A. and Calhoun F. (eds). *Replenishing soil fertility in Africa*. SSSA Special Publication No. 51. Pp. 151–192.

- Heinsey P.W. and Mwangi W.W. 1996. Fertilizer use and maize production in Sub-Saharan Africa. Economics working paper 96-100. CIMMYT, Mexico.
- Ikombo B. 1984. Effects of farmyard manure and fertilizers on maize in semi-arid areas of eastern Kenya. *E. Afr. Agric. For. J.* 44: 266-274.
- Jama B., Swinkels R.A. and Buresh R.J. 1997. Agronomic and economic evaluation of organic and inorganic resources of phosphorus in western Kenya. *Agronomy Journal* 89: 597-604.
- Kihanda F.M., Warren G.P. and Atwal S.S. 2004. The influence of goat manure application on crop yield and soil nitrate variation in semi-arid eastern Kenya. In: Bationo A. (Ed.) *Managing nutrient cycles to sustain soil fertility in sub-saharan Africa*. Tropical Soil Biology and Fertility Institute of CIAT, Nairobi, Kenya. pp.163-186.
- Mathuva M.N., Rao M.R. Smithson P.C. and Coe R. 1996. Improving maize (*Zea mays*) yields in semiarid highlands of Kenya: agroforestry or inorganic fertilizers? *Field Crops Research* 55: 57-72.
- Sanchez P.A., Shepherd K.D., Soul M.J., Place F.M., Buresh R.J. and Izac A-M.N. 1997. Soil fertility replenishment in Africa: An investment in natural resource capital. In: Buresh R.J., Sanchez P.A. and Calhoun F. (eds). *Replenishing soil fertility in Africa*. SSSA Special Publication No. 51. Pp.1-46.
- Stoorvogel J.J., Smaling E.M.A. and Hansen B.H. 1993. Calculating soil nitrogen balances in Africa at different scales: II supra-national scale. *Fert. Res. Fert. Res.* 35: 227-235.

On-Farm Evaluation and Scaling-up of Soil Fertility Management Technologies in Western Kenya

Odendo, M.^{1*}, Ojiem, J.¹, Bationo, A.² and Mudeheri, M.¹

¹Kenya Agricultural Research Institute (KARI), P.O. Box 169, Kakamega, Kenya, Telephone: +254 733 88 35 94, Email: Odendos@yahoo.com; ²Tropical Soil Biology and Fertility (TSBF) Programme, P.O. Box 30677, Nairobi, Kenya, Telephone: +254 2 524755/6, Email: a.bationo@cgiar.org., *Corresponding author.

Abstract

Low soil fertility is a fundamental constraint to crop production in western Kenya. Although researchers have developed many soil fertility-improving technologies, adoption of the technologies is low due to inadequate awareness of the technologies, poor access to requisite resources and unsuitability of the technologies to the farmers' conditions. On-farm experiments were conducted during 2002/3 long rain cropping seasons in two village clusters in Vihiga and Kakamega Districts in order to: introduce farmers to selected soil fertility improving options and elicit farmers' evaluation of the options; assess the economics of selected soil fertility management options under farmers' circumstances; and compare farmers' evaluations with the results of economic assessment. Five treatments were suggested to the farmers and through consensus, farmers chose to test three: 5 t ha⁻¹ FYM (Farm Yard Manure); 60 P kg ha⁻¹ plus 60 N kg ha⁻¹ (inorganic fertilisers); and 2.5 t ha⁻¹ FYM plus 30 kg P ha⁻¹ (inorganic fertilisers), alongside farmers' practice, using maize, the staple food, as a test crop. Farmers were involved in routine management, monitoring and evaluation of the experiments and field days were organised to introduce more farmers to the technologies. Results show that application of 30 kg P plus 2.5 t FYM ha⁻¹ gave economically viable yield response that was sustainable even under projected adverse decline in maize grain yield and increase in price of chemical fertilizers and the treatment was also the most preferred option by farmers. Results of this study should be used for validation of the promising options and planning of future experiments

Key words: Farmer-evaluation, maize, partial budget, scaling-up, soil fertility, western Kenya

Introduction

Agriculture is one of the most important sectors in the Kenyan economy. Indeed, the strategy adopted in the Eighth National Development Plan (GOK, 1997a) to transform Kenya into a newly industrialized country by the year 2020 is to rely on the closely linked sectors of agriculture and industry as twin engines for faster economic growth and development. In western Kenya, agriculture is mainly characterized by small-scale, subsistence-oriented mixed farming systems that incorporate crops and livestock (Odendo et al., 2002; MOA, 2002; MOA, 2003a). Declining crop

productivity, mainly due to continuous cultivation of soils without adequate plant nutrient replenishment, is a major challenge confronting farmers in western Kenya (Ojiem and Odendo, 1996; Nyambati et al., 2003).

Several soil fertility management technologies have arisen from decades of research, unfortunately, the technologies have not generated desired impacts amongst the target populations due to low or lack of adoption. The main reasons for the low adoption are lack of requisite resources, low farmers' awareness of the technologies and inappropriateness of the technologies to farmers' conditions (MOA, 2003b; Nyambati et al., 2003). Broad recommendations that

assume homogeneity of farming conditions have partly contributed to the low diffusion of fertilizer technologies. Hassan et al., 1998 reported that due to differences in climate, soil types and socio-economic conditions, productivity gains from fertilizer use by small-scale farmers are bound to vary, hence the need for careful targeting of fertilizer recommendations to a group of farmers who share similar circumstances and for whom the same recommendation is likely to be applicable. Such a group of farmers is referred to as a recommendation domain and it may be defined by agro-climatic and/or socio-economic circumstances (CIMMYT, 1988).

Adoption of farmyard manure in western Kenya as a low cost soil fertility improvement option is limited by low availability and low quality of the manures. Adoption rates of chemical fertilizers, on the other hand, are low despite farmers' knowledge of the benefits of their use (Hoekstra and Corbett, 1995) because of unreliability of returns to recommended 'packages' of hybrid seed and fertilizers (Anderson, 1992; Swinkles and Franzel, 1997) and lack of access to capital for purchasing the necessary inputs (Hoekstra and Corbett, 1995), and low awareness of farmers about the available soil fertility management technologies.

Farmers are likely to assess a technology with criteria and objectives, which are different from those used by scientists. Participation of farmers in research process helps scientists to design, test and recommend new technologies in light of farmers' preferences (Ashby, 1991). Farmer evaluation of technical alternatives is particularly useful in identification of relevant issues for adaptation of the technologies to specific local circumstances, thus improving likelihood of adoption. Most research on soil fertility management (SSSEA, 1999; Bationo, 2003; KARI, 2004) has, however, emphasized on technologies that have the ability to achieve high crop yield responses without taking into consideration farmers' evaluations and economic implications. Yield alone, however, does not reflect much about production efficiency or farmers' preference. Taking cognisance of the need to identify cost-effective soil fertility management options suitable for low income farmers, this study was set up to: introduce farmers to selected soil fertility improving options and elicit farmers' evaluation of the options; assess the economics of selected soil fertility management options under farmers' circumstances; and compare farmers' evaluations with results of the economic assessment.

Methodology

The study area

The study was conducted in Gisambai sub-location (Tiriki West Division) and Chimche sub-location (Kabras Division) in Kakamega and Vihiga Districts, respectively. A cluster of two villages was selected in each of the study sites. The villages for the study were selected following discussions between extension staff and researchers. Some of the key characteristics of the study sites are summarized in Table 1.

Kabras Division is relatively sparsely populated in relation to the other six Divisions of Kakamega District. The Division falls within a relatively high agricultural potential area, with a third of its landmass falling within the high potential Upper Midland (UM₁) and Lower Midland (LM) agro-ecological zones (Jaetzold and Schmidt, 1983). Chimche sub-location falls in LM₁. Altitude ranges between 1300 and 1500 metres above sea level (masl). The mean annual temperature is 21°C. There is a significant variability of soils. The predominant soil type is Nito-rhodic ferralsols. Other important soil types are Acrisols, Combisols and Gleysols. The soils were mainly developed from granites and are well-drained, very dark, dusky red to yellowish red and in some places the soils are friable clay loams with acid humic topsoil (Jaetzold and Schmidt, 1983; MOA, 2003a).

Tiriki East Division, on the other hand, is one of the six administrative Divisions of Vihiga District. It falls in the UM₁ and altitude ranges between 1600 and 1800 masl. Temperatures range between 14°C and 32°C, with minimum diurnal variations. Soils are related to the underlying rocks. The granite rock has given rise

Table 1. Key characteristics of Kabras and Tiriki West Divisions, western Kenya

Characteristics	Kabras	Tiriki West
Area (km ²)	429	91
Population density (persons/km ²)	386	1024
Average farm size (ha)	1.4	0.6
Average household size (number)	7	8
Annual rainfall (mm)	1500–1800	1800–2000
Main cash crops	Maize, sugarcane	Tea, coffee, French beans, Eucalyptus sp.

Source: GOK, 1997b; MOA, 2003a.

to light-brown, sandy-loams, which are susceptible to soil erosion. Approximately 90% of the soils have low inherent fertility due to heavy leaching, erosion and poor management (Jaetzold and Schmidt, 1983). Rainfall is about 80% reliable and well distributed throughout the year (GOK, 1997b), thus climate is not a limiting factor to crop production.

The two study sites receive bi-modal rainfall pattern-long rain season is from February/March to July and short rains between August and November. The two seasons are, however, not distinct as they often overlap. Maize, often intercropped with beans, dominates the cropping patterns and is grown by almost all households, especially during the long rains. Low crop yields especially of maize and low milk yields are major problems affecting the farming households in both Divisions. Declining soil fertility, use of unimproved crop varieties and poor crop management are factors often cited for the low yields (MOA, 2002; MOA, 2003b). The use of purchased inputs is limited mainly by high costs, low producer price of most food crops, inefficient distribution systems, and erratic availability of the inputs, especially fertilizers (Ojiem and Odendo, 1996; Nyambati et al., 2003).

Choice of treatments and design of the experiment

Meetings were held at the initiation of the study to sensitise extension staff and farmers in the selected sites on improved soil fertility management technologies available from KARI and other research and development partners. Focus group discussions and key informant interviews were held to discuss soil fertility management practices and constraints, suggest to the farmers technologies likely to address the constraints and choose treatments for experimentation. Farmers were introduced to five main options: recommended rate of 60 kg P and 60 kg N ha⁻¹ from Di-ammonium Phosphate (DAP) and Calcium Ammonium Phosphate (CAN) (N60P60); recommended rate of farmyard manure (FYM) (5 tons ha⁻¹) (5t FYM); 2.5 t FYM ha⁻¹ plus 30 P ha⁻¹ from DAP (30PFYM2.5); *Tithonia* biomass transfer; and green manure legumes. Whilst *Tithonia* and green manure legumes are relatively new technologies in the study areas, the rest are amongst the broad recommendations for soil fertility management in western Kenya. Farmers were asked to select three treatments from the list of the proposed treatments, which were tested alongside farmers' practice that varied from farm to farm. Through negotiations and

consensus building, the farmers desired to test N60P60, 5t FYM and 30PFYM2.5. Incidentally, the farmers did not choose *Tithonia* and green manure legumes hence all the farmers had four common treatments, including farmers' practice.

During the planning phase of the study, the researchers and extension workers informed farmers that previous studies had shown that DAP lowers soil pH and recommended that Triple Super Phosphate (TSP) be applied as inorganic source of phosphorous (P). The farmers, however, asserted that TSP was not available in the local markets, hence they chose DAP, which is common in local markets. At both study sites, farmers selected maize as the test crop because it is a staple food and most farmers give it first priority when applying soil-improving inputs. The most popular maize hybrid grown at both sites, H614D, was selected and planted using recommended spacing of 75 cm × 30 cm. The hybrid (H614D) is late maturing (6–8 months, depending on altitude) and yield about 6.6 t ha⁻¹ under researcher-managed trials.

The farmers who attended the planning meetings selected ten and eight farmers in Tiriki West and Kabras sites, respectively, to host the experiments on their behalf. Researchers and extension workers designed the layout of the experiment in such a manner that farmers could stand at the centre of the experiment and observe all the four treatments and conveniently make objective comparison of the treatments. Plot sizes were variable, depending on the land size farmers afforded to allocate to the trials, but generally the size of each plot was 10 m × 10 m. Four treatments were planted per farm in a randomised complete block design (RCBD), without replication. The farmers that hosted the experiments were responsible for routine management of the experiments according to their affordable management levels and they were encouraged to make any adaptations they considered important. However, researchers and extension workers provided farmers with information regarding the recommended management practices.

Data collection and analysis

Data were obtained from farmers who hosted the experiments during routine monitoring of the experiments and socio-economic data were crosschecked at the community level through focus group discussions and key informant interviews in the study- and contiguous villages. A team of researchers and

extension workers guided farmers to list inputs required for each treatment. Data were collected on amounts of labour used in reported labour requiring activities, fertilizer applied, and maize yields obtained. Labour was measured in person-days of the actual work done in the fields. Average prices of inputs at planting period and farm-gate prices of output at harvest in 2002/3 long rain seasons were also collected. Mean prevailing market wage rates were collected from farmers and used to value hired labour and as opportunity cost for labour provided by household members. Production costs and maize grain yields were derived by extrapolation of costs of inputs and plot yields, expressed in Kenya shilling (KSh.) per hectare.

Analysis of variance (ANOVA) was used to assess maize grain yield, whilst partial budget technique as described by CIMMYT (1988) was applied to the maize grain yield results. As the term partial budget implies, only those changes in costs and returns that are affected by the alternative scenarios are considered. The costs that do not differ across the different scenarios will be incurred regardless of which treatment is used and are therefore excluded from the calculation because they are not relevant to the particular decision. Such costs do not affect the farmers' choices concerning soil fertility management technology to apply and are ignored for the purpose of this decision. The costs of land rent, land preparation, weeding and seed did not vary across the treatments and were thus not considered in this analysis because farmers applied these inputs equally, regardless of the treatment.

The first step in partial budget analysis is calculation of net benefits (NB) as shown in formula (1).

$$NB = (Y \times P) - TCV \quad (1)$$

Where

$(Y \times P)$ = Gross Field Benefit (GFB)

Y = Yield per ha

P = Field price per unit of the crop

TCV = total costs that vary for the treatment (excluding costs associated harvesting and marketing).

Field prices and costs were used in computation of the net benefits to reflect all costs farmers incur to have inputs on their fields and the actual prices they receive for their output. Next, dominance analysis was used to select potentially profitable treatments from the range that was tested. The selected and discarded treatments using dominance analysis are referred to as un-dominated and dominated, respectively. The treatments were listed in order of increasing TCV and any

treatment that had net benefits less than or equal to those of a treatment with lower costs that vary was dominated, thus eliminated from further analysis. This is because no economically rational farmer, given an alternative, will choose a practice whose contribution to yield increase is not enough to compensate for increment in costs that vary. However, this does not provide a firm recommendation. Therefore, a marginal rate of return (MRR) was computed to compare increments in costs and benefits of the non-dominated scenarios. The comparison of MRR is important to farmers because they are interested in seeing the increase in costs required to obtain a given increase in net benefits.

$$MRR \text{ (between } a \text{ and } b) (\%) = \frac{(NB_b - NB_a)}{(TCV_b - TCV_a)} \times 100 \quad (2)$$

Where a is the next soil fertility management (SFM) option with higher TCV and b is the previous SFM with lower TCV. Thus, MRR does not refer to a particular treatment, but rather of the change from one treatment to another because it appears between treatments.

Formula (2) implies that MRR will always be positive since dominated treatments are not included. The MRR between pairs of un-dominated treatments denotes what farmers expect to gain on average in return for their investment when they decide to change from one practice (or a set of practices) to another. In this study, MRR reveals how the net income from an investment in a given soil fertility management option increases as the amount of invested TCV increases. An MRR of 100%, for example, implies a return of one unit for each unit of expenditure on given variable input under a particular soil fertility improvement option. Although only costs that vary are included in computation of MRR, when MRR is calculated using benefits and total costs, the result is the same (CIMMYT, 1988). Whilst marginal analysis shows the worth of different soil fertility management options, farmers' decisions to invest in soil fertility management options are not restricted to profit maximization alone. Farmers' perceptions and evaluation based on their own criteria is also important in their decision-making.

The farmers who hosted the experiments, other farmers from the study village clusters and from the neighbouring villages were involved in monitoring and evaluation of the experiments. To scale-up results of the study, towards the end of each cropping season, farmers and key informants from within communities of each of the study village clusters and outside the

study divisions were invited to attend fields. To elicit farmers' perceptions and feedback about the trials, during monitoring and field days farmers were facilitated by researchers and extension staff to identify criteria upon which they systematically evaluated the options in addition to their subjective ranking of the options.

Farmers also take into account the possible variability in results due to changes in biophysical and socio-economic environments. Although such changes may be difficult to predict with accuracy, they are the risks the farmers have to confront. A sensitivity analysis, which involves redoing marginal analysis, was carried out to review the robustness of the MRR to likely decline in maize grain yields and increase in price of chemical fertilizers.

Results and discussion

Maize response to soil fertility improvement options

During the year 2002 and 2003 long rain cropping seasons, mean maize grain yields from the plots where soil fertility improvement inputs were added were significantly different from where they were not (Table 2). In Kabras, application of 30 kg P plus 2.5 t FYM ha⁻¹ (P30FYM2.5) gave significantly different yields from the use of 5 t ha⁻¹ FYM (5t FYM). As expected, non-application of soil fertility improving inputs (N0P0) gave the lowest yields in both study sites. Application of 60 kg P plus 60 kg N ha⁻¹ (N60P60) from inorganic fertilizers gave the highest maize grain yield (4,160 kg ha⁻¹) in Tiriki West, whilst in Kabras

P30FYM2.5 gave the highest maize grain yield (4,225 kg ha⁻¹), followed by 60 kg P plus 60 kg N ha⁻¹ from DAP and CAN.

Variability in maize grain yields between the seasons was relatively high as reflected by the standard deviations (Sd). The highest Sd (2802) was obtained from application of N60P60 in Tiriki West, whilst N0P0 gave the most stable yields in both the study sites (Table 2).

Economic evaluation of the soil improvement options

A review of socio-economic data shows that the study sites belong to different recommendation domains. Production costs and output values are variable as shaped by input and output quantities and prices. Therefore, it was plausible to analyse the two study sites as separate entities rather than pool the results. However, the results from each village cluster were pooled for the analysis. Results of partial budget analysis are shown in Table 3. The values of the partial budget represent mean discounted costs and benefits resulting from application of different options (See appendix 1 for details). The present value of benefits and costs were calculated from stream of benefits (value of grain maize) and costs from residual effects of soil fertility management options in the two years. A 20% interest rate per annum, which was the average cost of capital prevailing during the study period, was used to estimate the present value of future cash flows (discounting). Assessment of residual value of manure on the yield is always difficult because of expenses required and the commitment needed to maintain the assessment for several seasons. The greatest challenge of this study was determination of economic life of residual effect of manure, which is essential in economic assessment. For this study the assumption was that economic life of the residual effect of manure was about four cropping seasons (F. Kihanda, personal communication).

In this study, any technology that contained manure was taken as an investment and benefits and costs were discounted to capture residual effects because when a farmer applies manure, crop outputs (benefits) are obtained for more than one season because of residual effects. Although CIMMYT (1988) recommends a downward adjustment of crop yield for economic analysis, in this study, yields were not adjusted because the data were generated from farmer-managed trials. Highest net benefit of Ksh. 31,651 ha⁻¹ were obtained in Tiriki West from application of the recommended inorganic fertilizer rate, whilst the lowest as expected,

Table 2. Mean maize grain yields in Tiriki West and Kabras Divisions in 2002 and 2003 long rains

Treatment	Mean maize yield (kg ha ⁻¹)	
	Tiriki West	Kabras
N60P60	4160 a (2802)	3729 a (1978)
P30FYM2.5	3798 a (2220)	4225 ab (1467)
5 t FYM	2974 a (1963)	2644 b (1454)
N0P0	790 c (124)	983 c (211)
LSD	1242	1430
CV (%)	40	33

Note: 1) Mean values with the same letter(s) are not significantly different ($p = 0.05$); 2) Figures in parenthesis are standard deviations.

Table 3. Partial budget analysis of soil management options at current prices

Variable	N60P60		P30FYM2.5		5t FYM		NOPO	
	T.West	Kabras	T.West	Kabras	T.West	Kabras	T.West	Kabras
GFB (Ksh ha ⁻¹)	40,020	30,772	32,917	34,897	25,727	21,780	6,843	11,797
TCV (Ksh ha ⁻¹)	8,369	9,284	6,258	6,785	6,921	6,485	1,375	1,513
NB (Ksh ha ⁻¹)	31,651	21,488	26,659	28,112	18,806	15,294	5,468	10,285

1US dollar = Ksh. = 75.00.

were obtained from farmers' practice, Ksh. 5, 468 ha⁻¹ and Ksh. 10, 285 ha⁻¹ in Tiriki West and Kabras, respectively (Table 3).

Dominance analysis led to selection of non-dominated treatments, which were ranked in order of increasing TCV for further analysis. In Tiriki West, application of 5t FYM was dominated and thus eliminated from further analysis. Changing from non-application of any soil amendments (common farmers' practice) to applying 30PFYM2.5 resulted in MRR of 434%, whilst changing from 30PFYM2.5 to N60P60 reduced MRR to 237% (Table 4). Thus, for each shilling invested in 30PFYM2.5 and N60P60, the farmers recovered the shilling plus KSh.4.34 and 2.37, respectively. As a guideline, an MRR below 100% is considered low and unacceptable to farmers (CIMMYT, 1988). This is because such a return would not offset the cost of capital and other transaction costs while still providing an attractive gross margin to serve as incentive.

At the Kabras site, application of N60P60 was eliminated from further analysis by dominance technique to remain with NOPO, 30PFYM2.5 and 5t FYM as the promising soil fertility management options under the prevailing market prices. Changing from NOPO to applying 5t FYM resulted in MRR of 101%, whilst

changing from 5t FYM to 30PFYM2.5 resulted in MRR increasing to 4273%. This was occasioned by a relatively high increase in net benefits (Ksh. 12,818) and minimal increase in marginal costs (KSh. 300). The most economically viable option was not necessarily the one with highest net benefits or yield (Table 4).

The results of MRR analysis in Tiriki West contrasts, while those of Kabras site support the findings of a study conducted in the medium potential areas of Embu district (Gitari et al., 1996) and a study done in western Kenya (Shiluli et al., 2003). Gitari et al., 1996 showed that changing from 20 kg N and 20 kg P ha⁻¹ to 50 kg N and 50 kg P ha⁻¹ (recommended fertilizer rate for Embu), resulted in 50 kg N and 50 kg P ha⁻¹ being dominated in both long and short rain seasons, thus not subjected to further MRR analysis, implying that the recommended fertilizers rate was unprofitable. An economic assessment of the effect of different combinations of N and P from chemical fertilisers on maize yield, conducted in Yala Division, Siaya District, western Kenya (Shiluli et al., 2003) shows that changing from farmers' own practice to application of 30 kg N ha to 60 kg N 40 kg P ha⁻¹ and finally 90 kg N 80 kg P ha⁻¹ in that order gave MRRs of 363%, 206%, and 36%. Thus, MRRs declined as the higher doses of fertilizer (towards the recommended fertilizer rates) were applied. The results of combination of organic and chemical fertilizers in both sites support the findings of a similar study in Zimbabwe (Mutiro and Murwira, 2004), which demonstrated that greater benefits were obtained when manure was supplemented with some chemical fertilizers. Again, Mutiro and Murwira (2004) reported that using 5 t FYM ha⁻¹ produced a yield advantage of 84% compared to not using any soil-fertility adding inputs. Whilst supplementing 5 t ha⁻¹ FYM with 40 kg N ha⁻¹ produced highest rate of return of 134%.

The findings of this study show that MRR increases, but not necessarily profitable, when farmers apply some soil fertility improving inputs. It is, therefore, not economically viable for farmers to plant maize without

Table 4. Dominance and marginal analyses of soil fertility options

Site/treatments	TCV	NB	MC	MR	MRR
<i>Tiriki west</i>					
NOPO	1,371	5,468			
P30FYM2.5	6,258	26,659	4,887	21,191	434
5t FYM	6,921	18,806 D			
N60P60	8,369	31,651	2,111	4,992	237
<i>Kabras</i>					
NOPO	1,513	10,284			
5t FYM	6,485	15,294	4,972	5,010	101
P30FYM2.5	6,785	28,112	300	12,818	4,273
N60P60	9,284	21,488 D			

D = dominated.

application of any soil fertility improving inputs. However, farmers continue to grow maize without soil amendments in their struggle to meet subsistence requirements and for social, cultural and economic reasons. The community perceives farmers who do not grow some maize as lazy or very poor, the perceptions most farmers hate to be associated with for fear of loss of their social status, though they may be actually poor or lazy. On the other hand, application of fertilizers in the study sites is limited mainly by high costs and low producer price of most food crops. A few farmers that use chemical fertilizers cannot afford the recommended rates owing to liquidity constraints.

It is, however, difficult for small-scale farmers to access credit from formal credit institutions to buy fertilizers and other farm inputs owing to stringent credit conditionality, especially demand for collateral (e.g., least 5 acres of land), high interest rates and high risks associated with agricultural enterprises. In view of this, one of the strategies to improve farmers' access to credit is through catalysing the farmers to form groups and building the groups' capacity on credit management so that micro-finance institutions could use such groups to channel credit to farmers on soft terms using social capital as security. However, to convince the smallholder farmers to seek credit for buying fertilizers to apply on maize, it is crucial to demonstrate to the farmers fertilizer technologies that are profitable.

Recalculation of the partial budget using a set of likely adverse changes of the environment was necessary to pinpoint treatments that are likely to remain profitable and sustain acceptable returns for farmers despite the changes. In this case, the most likely risk scenarios were lower deviations of maize grain yields from the means (mean grain yield minus standard deviation) (Table 2) and a rise in price of chemical fertilizers. Based on own historical experience, the price of chemical fertilizers rose by 27%, *ceteris paribus*, during the study period.

Using lower deviations of maize grain yields from the means, dominance analysis resulted in only NOP0 and 30PFYM2.5 being un-dominated at both the study sites (Table 5). In Tiriki West, none of the changes between treatments was profitable because of generally high standard deviations. However, a change from NOP0 to 30PFYM2.5 was profitable (MRR 267%) in Kabras (Table 5).

Dominance analysis of effect of 27% increase in price of chemical fertilizers, on the other hand, resulted in 5t FYM and N60P60 being dominated in Tiriki West and Kabras, respectively (Table 6). In Tiriki West, a

Table 5. Dominance and marginal analyses with lower deviation of maize grain from the means

Site/treatments	TCV	NB	MC	MR	MRR
<i>Tiriki West</i>					
NOP0	1,375	5,035			
P30FYM2.5	6,258	8,931	4,883	3,896	80
5t FYM	6,921	2,810 D			
N60P60	8,369	4,702 D			
<i>Kabras</i>					
NOP0	1,513	5,564			
5t FYM	6,485	4,423 D			
P30FYM2.5	6,785	1,8497	5,272	1,4074	267
N60P60	9,284	6,764 D			

D = dominated.

Table 6. Dominance and marginal analyses with a 27% increase in price of chemical fertilizer

Site/treatments	TCV	NB	MC	MR	MRR
<i>Tiriki West</i>					
NOP0	1,746	5,097			
P30FYM2.5	8,572	24,345	6,826	19,248	282
5t FYM	8,789	16,938 D			
N60P60	12,784	27,232	4,212	2,892	69
<i>Kabras</i>					
NOP0	1,921	9,876			
5t FYM	8,236	13,543	6,315	3,667	58
P30FYM2.5	9,289	25,608	1,053	12,065	1,146
N60P60	14,141	16,631 D			

D = dominated.

change from NOP0 to 30PFYM2.5 resulted in MRR of 282%, and a change from 5t FYM to N60P60 was un-profitable (MRR, 69%). In Kabras, changing from NOP0 to 5t FYM was unprofitable (MRR 58%), whilst a change from 5t FYM to 30PFYM2.5 remained profitable (MRR, 1,146%), though only about a quarter of the MRR obtained from using current input and output prices and mean grain yields.

Finally, considering simultaneous lower deviations of maize grain yield from the mean and 27% increase in price of chemical fertilizers, all changes in treatments became un-profitable except the change from NOP0 to 30PFYM2.5, which was marginally profitable (MRR 147%) in Kabras (Table 7).

The results demonstrate the need for integration of organic and inorganic soil fertility management inputs to obtain economically viable options. Kihanda et al. (forthcoming) assert that manure is usually in short supply, bulky and heavy, requiring substantial labour to apply it, and does not produce all the required nutrients but are more environmental friendly and provide

Table 7. Dominance and marginal analyses with simultaneous lower deviation of maize grain from the means and 27% increase in prices of chemical fertilizers

Site/treatments	TCV	NB	MC	MR	MRR
<i>Tiriki West</i>					
N0P0	1,746	4,664			
P30FYM2.5	8,572	6,616	6,826	1,952	29
5t FYM	8,789	941 D			
N60P60	12,784	287 D			
<i>Kabras</i>					
N0P0	1,921	5,156			
5t FYM	8,236	2672 D			
P30FYM2.5	9,289	15,993	7,368	10,837	147
N60P60	14,142	1906 D			

D = dominated.

long-term beneficial effects to the soils than chemical fertilizers. However, chemical fertilizers, which are a more concentrated form of nutrients, are expensive, thus more difficult for farmers to access and cannot maintain soil fertility as well as manure in the long run. Based on good residual value, manure can be applied intermittently and supplemented by mineral fertilizers in intermediate years to boost levels of immediately available nutrients. Combining also helps to maintain soil pH at a favourable level for nutrient accessibility.

Farmers' assessment and dissemination of technologies

One hundred and twenty two farmers, comprising 70 women and 52 men, attended the four field days that were held. Farmers' assessment by scoring and ranking of the different soil fertility management options during the field days and focus group discussions revealed

interesting aspects of investment decisions in soil fertility management at farm level. Farmers used combinations of criteria in selecting the options they preferred. The criteria that were frequently cited by the farmers for preference of different soil fertility management options and related scores and ranks are shown in Table 8.

Mean scores associated with these criteria are interpreted as reflecting importance of the criteria to farmers. The important criteria, in decreasing order of importance, at both study sites were ability of the option to increase maize yield, cost of requisite inputs, longevity of obtaining good maize yield after application of the option and availability of required inputs in the study area (Table 8). Longevity of obtaining good yield referred to the ability of the option to generate good yields from residual effects upon application, thus reducing the need to apply the option every season, which is more preferred due to liquidity constraints the farmers face. Thus, options containing farmyard manure were highly rated. Through scoring, 30PFYM2.5 emerged the most preferred option. Using subjective ranking method, whereby farmers were asked which of the treatment they preferred most, majority of the farmers (75%) expressed preference for 30 kg P plus 2.5 tons FYM. There was similarity in ranking of the treatments across the sites. Farmers' evaluations reflect their preference for cost-effective treatments and shows that farmers are willing to sacrifice high yields by applying soil fertility management options that minimize costs.

Results of conventional economic analysis were similar to those of farmers' evaluation. In general, however, it is farmers' perceptions that determine which technology farmers will adopt, thus emphasizing the need to take into cognisance farmers' perceptions and evaluation of the technologies during technology development and dissemination.

Table 8. Most frequently cited criteria farmers used to evaluate soil fertility management options in western Kenya

Criterion	N60P60		P30FYM2.5		5t FYM		N0P0		Mean Score
	T.West	Kabras	T.West	Kabras	T.West	Kabras	T.West	Kabras	
Increases maize yield	3.5	4.6	4.5	4.7	3.5	3.6	1.1	1.2	3.5
Cost of requisite inputs	1.7	1.9	3.0	4.5	2.8	3.2	na	na	1.7
Longevity of obtaining output	2.4	3.0	2.9	3.4	3.8	4.3	na	na	2.4
Availability of inputs	2.0	1.2	3.1	4.3	2.1	3.5	na	na	2
Total score	9.6	10.7	13.5	16.9	12.2	14.6	1.1	1.2	–
Rank	3	3	1	1	2	2	4	4	–

Scale: 1 = Worst, 5 = Excellent; na = not applicable.

Conclusions

Maize grain yields from the plots where soil fertility improvement inputs were added were significantly different from where they were not. Of the three treatments that were tested against farmers' practice, application of 30 kg P plus 2.5 t FYM ha⁻¹ gave economically viable yield response that was sustainable even under projected adverse deviation of maize grain yield from the mean and increase in price of chemical fertilizers. Farmer evaluations of the treatments were similar to the conventional economic analysis. The study shows that manure and chemical fertilizers should be used as complementary methods of soil fertility improvement to minimize costs and increase profitability.

The study shows that broad recommendations that assume homogeneity of farming conditions are not suitable for farmers in the two study sites and demonstrates that agronomic results alone do not provide a complete picture when assessing a given technology and needs to be supplemented by economic analysis and farmer evaluations. Therefore, to enhance adoption, there is need for targeting of recommendations to groups of farmers who share similar circumstances and involving them in the research process. This study is based on a two-season data, hence the results should

be used to validate the viable options for least two seasons and planning of future experiments in light of the present and anticipated future farmers' circumstances so as to make more reliable recommendations. It is recommended that the promising soil fertility improvement options be evaluated on high value crops, especially horticultural crops, which have high potential of improving MRR and being acceptable to farmers.

Acknowledgements

This research was made possible by financial support of the Rockefeller Foundation through TSBF/AfNet, to which we are very grateful. We thank the Centre Director, KARI-Kakamega for his support. Many thanks to our colleagues in KARI, particularly Patrick Oucho and Henry Wakhonya, for facilitating planting of the trials and collection of data, and to the Ministry of Agriculture staff for their help in identifying and establishing rapport with farmers. The contribution of the farmers, who sacrificed their land for experiments and time to discuss with us, is highly appreciated. Finally, we are grateful to two anonymous referees for making substantial suggestions for improvement of the paper.

Appendix 1. Partial budget analysis of soil fertility management options at current prices

Variable	N60P60		P30FYM2.5		5t FYM		NOPO	
	T.West	Kabras	T.West	Kabras	T.West	Kabras	T.West	Kabras
Maize yield (bags*/ha)	46	37	38	42	30	26	8	14
Maize price (Ksh. per bag)	945	900	945	900	945	900	945	900
Year 0: GFB (Ksh/ha)	43,659	33,570	35,910	38,070	28,067	23,760	7,466	12,870
Year 1: GFB	36,381	27,974	29,924	31,724	23,388	19,799	6,221	10,725
Mean GFB	40,020	30,772	32,917	34,897	25,727	21,780	6,843	11,797
Manure	0	0	1,938	1,813	3,875	3,625	0	0
Fertiliser	6,858	7,481	1,989	2,139	0	0	0	0
Labour: Planting	1,875	2,250	2,900	3,450	3,675	3,450	1,500	1,650
Labour: Topdress	400	400	0	0	0	0	0	0
Year 0: TCV	9,130	10,128	6,827	7,402	7,550	7,075	1,500	1,650
Year 1: TCV	7,608	8,440	5,689	6,168	6,291	5,896	1,250	1,375
Mean TCV	8,369	9,283	6,258	6,785	6,921	6,485	1,375	1,513
NB	31,651	21,488	26,659	28,112	18,806	15,294	5,468	10,285

1. *1 bag = 90 kg. In Kenya, 90-kg bag is the most widely used unit in maize marketing; 2. Ksh. = Kenya Shilling; 1USD (U.S dollar) = Ksh. 75.00; 3. GFB = Gross field benefits; TCV = total variable costs; NB = Net benefits; 4. Field price of manure: Kabras Ksh. 775.00 per ton; Tiriki West = Ksh. 725.00 per ton; 5. Field price of fertilizers: DAP (18:46:0)- Ksh. 30.50 per kg in Tiriki West; Ksh. 32.80 per kg in Kabras; CAN (26% N): Tiriki West Ksh. 20.50 per kg; Kabras Ksh. 22.80 per kg; 6. Labour for planting using N60P60: Tiriki West 18.75 man days (MD) at Ksh. 100.00 per MD; Kabras: 22.5MD at 100.00 per MD; 7. Labour for planting using P30FYM2.5: Tiriki West 29 MD at 100.00 per MD; Kabras 34.5 MD at 100.00 per MD; 8. Labour for planting without fertilizer: 15 MD at 100.00 per MD in Kabras; 16.50 MD at Ksh. 100.00 per MD in Tiriki West; 9. Labour for top dressing: in Tiriki West and Kabras: 5 MD at 80.00 per MD; 10. Costs and benefits were discounted at 20% (0.8333) per annum for year 1; 11. Year 0 = 2002 and year 1 = 2003; 12. The unit of measure for GFB, cost of inputs (manure, labour, and fertiliser), and TCV are KSh/ha.

References

- Anderson J.R. 1992. Difficulties in African Agricultural Systems Enhancement: Ten Hypotheses. *Agricultural Systems* 38: 387–409.
- Ashby J. 1991. Adopters and Adapters. Participation of Farmers in On-farm Research. In :
- Bationo A (ed.) 2003. *Managing Nutrient Cycles to Sustain Soil fertility in sub-Saharan Africa*. Academy Science Publishers, Nairobi, Kenya.
- CIMMYT (International Maize and Wheat Improvement Centre). 1988. *From Agronomic Data to Farmer Recommendations: An Economics Training Manual*. Completely Revised Edition. CIMMYT, Mexico, DF.
- Hassan R.M. and Ransom J.K. 1998. Determinants of the Incidence and Severity of Striga Infestation in Maize in Kenya. In: Hassan R.M. (Ed.). *Maize Technology Development and Transfer: A GIS Application for Research Planning in Kenya*. CAB International/CIMMYT/KARI, Wallingford United Kingdom. pp. 163–174.
- Hoekstra D. and Corbett J. 1995. *Sustainable Agricultural Growth for the Highlands of East and Central Africa: Prospects to 2020*. Paper Prepared for the International Food Policy Research Institute (IFPRI). Eco Regions for the Developing World: A Lens for Assessing Food, Agriculture and the Environment to the Year 2020.
- Gitari J.N., Kanampiu F.K. and Murithi F.M. 1996. Maize Yield Gap Analysis in Mid-Altitude Areas of Eastern and Central Region. In: *Proceedings of 5th KARI Scientific Conference*, October 1996, KARI, Nairobi, Kenya. pp. 216–222.
- GOK (Government of Kenya) 1997a. *National Development Plan of Kenya (1997–2001)*. Government Printer, Nairobi, Kenya.
- GOK 1997b. *Vihiga District Development Plan (1997–2001)*. Government Printer, Nairobi, Kenya.
- Jaetzold R. and Schmidt H. 1983. *Farm Management Handbook: Natural and Farm Management Information Vol. II/B*. Ministry of Agriculture and Livestock Development, Nairobi, Kenya.
- KARI 2004. *KARI Annual Report 2003*. KARI, Nairobi, Kenya.
- MOA (Ministry of Agriculture) 2003a. *Annual Report, Kabras Division*: MOA, Kakamega, Kenya.
- MOA 2003b. *Annual Report, Vihiga District*: Vihiga. MOA, Vihiga, Kenya.
- MOA.2002. *Annual Report, Ministry of Agriculture, Kakamega District*: MOA, Kakamega, Kenya.
- Mutiro R.K. and Murwira H.K. 2004. The Profitability of Manure Use on Maize in the Smallholder Sector of Zimbabwe. In: Bationo A. (Ed). *Managing Nutrient Cycles to Sustain Soil fertility in sub-Saharan Africa*. Nairobi, Kenya. Academy Science Publishers. pp. 571–582.
- Nyambati, E.M., Mureithi, J.G. and Wamwuongo J.W. 2003. *Soil Fertility Improvement Technologies for Western Kenya: Synthesis Report of Soil Management Research Project (1994–2002)*. KARI Technical Note Series no. 30, KARI, Nairobi, Kenya.
- Odendo M., De Groote H. and Odongo O.M. 2002. Assessment of Farmers' Preferences and Constraints to Maize Production in Moist Mid-Altitude Zones of Western Kenya. In: *Proceedings of the 5th International Conference of the African Crop Science Society (ACSS)*, Lagos, Nigeria, October 21–26, 2001. Makerere University, Kampala, Uganda. pp. 769–775.
- Ojiem J. and Odendo M. 1996. Biological Management of Soil Fertility in Kabras and Vihiga Divisions of Western Kenya. Second Annual Report to the European Union. In: Carter S.E. (ed.) *Biological Management of Soil Fertility in Small-Scale Farming Systems in Tropical Africa*. TSBF, Nairobi. pp. 98–121.
- Shiluli M.C., Macharia C.N. and Kamau A.W. 2003. Economic Analysis of Maize Yield Response to Nitrogen and Phosphorous in the Sub-humid Zones of Western Kenya. *African Crop Science Journal* II, 3:181–187.
- SSSEA (Soil Science Society of East Africa). 1999. *Proceedings of the 17th Annual General Meeting and Conference of the Soil Science Society of East Africa*, Kampala, Uganda, September 6–10, 1999. Makerere University, Kampala, Uganda.
- Swinkles R. and Franzel S. 1997. Adoption Potential of Hedgerow Inter cropping in Maize-based Cropping Systems in the Highlands of Western Kenya 2. Economic and Farmers' Evaluation. *Experimental Agriculture* 33:211–223.
- Thripp (ed.) *Planned Change in Farming systems, Progress in On-farm Research*. John Wiley and Sons, New York. pp. 273–286.

The Resources-to-Consumption System: A Framework for Linking Soil Fertility Management Innovations to Market Opportunities

Sanginga Pascal C.^{1*}; Susan Kaaria¹, Robert Muzira², Robert Delve³, Jemimah Njuki³, Bernard Vanlauwe⁴, Jonas Chiarm⁴ and Nteranya Sanginga⁴

¹International Centre for Tropical Agriculture, Kampala, Uganda; ²CIAT-Kabale, Uganda; ³Tropical Soil Biology and Fertility Institute of CIAT (TSBF-CIAT); Harare-Zimbabwe; ⁴Tropical Soil Biology and Fertility Institute of CIAT (TSBF-CIAT); Nairobi-Kenya; *Corresponding author, CIAT, Kawanda Agricultural Research Institute; P. O. Box 4267 Kampala, Uganda, Tel: +256 41567670; Fax +25641567635, Email:P.Sanginga@cgiar.org

Abstract

Recent paradigms in soil fertility management research have evolved from the initial reductionist approaches of nutrient replenishment to embrace a more holistic integrated soil fertility management (ISFM) approach that goes beyond soils to address the full chain of interactions, from resources to production systems, to markets and policies. It is now recognized that the adoption of ISFM technologies critically depends on market opportunities. It is argued that without well functioning markets, the adoption of ISFM innovations will remain limited. This paper examines this “market-led hypothesis” that linking farmers to better market opportunities will provide incentives for adoption and re-investment in ISFM innovations. This hypothesis is tested with empirical data from cross-sectional household surveys and action research on linking farmers to markets in selected sites in Malawi, Uganda and Tanzania. Analysis revealed mixed results, with significant differences based on gender, wealth categories, crops and areas. On one hand, there is evidence that better access to markets and increased income led to positive investments in agricultural inputs, increased fertilizer use and soil conservation measures. On the other hand, for the majority of women and poor farmers, particularly in Uganda, re-investing in ISFM was not even among the first three priorities, compared to other livelihood needs (buying or renting more farmland, livestock, paying school fees and buying clothes). The paper outlines a novel approach for demand-driven and market-led ISFM research for development. This approach termed the Resource-to-Consumption offers a practical framework to link ISFM research to market opportunities identification in a way that empowers farmers to better manage their resources and offers them incentives to invest in soil fertility improvement. The success of this approach is highly dependent on the development of effective quality partnerships with research and extensions systems, government and non-governmental organizations, business support services, farmer communities and the private sector; and building multi-institutional and trans-disciplinary research for development teams, with complementary skills and expertise. The paper suggests four key areas that need concerted efforts by a variety of stakeholders (i) improving output and input market access; (ii) participatory technology development; (iii) strengthening farmers’ institutions, and (iv) influencing policy change

Key words: participatory research, market opportunities, soil fertility, resource-to-consumption, Africa

Introduction

For several decades, natural resource degradation, and in particular soil fertility decline, have been recognized

as one of the major biophysical constraints affecting African agriculture (Bationo et al., 2006; Giller, 2001; Sanchez et al., 1997). At the same time, tremendous progress has been made in developing a variety

of technologies and innovations for replenishing soil fertility (Bationo et al., 2006; Sanginga et al., 2003; Vanlauwe et al., 2002; Nandwa, 2003; Giller, 2001; Buresh et al., 1997). The principle constraint to greater impact of soil fertility research is not so much a lack of scientific excellence or expertise, or technologies but rather the failure to integrate soil fertility management research across disciplines, and particularly linking research to market opportunities.

Recent paradigms in soil fertility management research have evolved from the initial reductionist approaches of nutrient replenishment to embrace a more holistic integrated soil fertility management (ISFM) approach. The ISFM paradigm advocates the best combination of available nutrient management technologies that are economically profitable and socially acceptable to different categories of farmers (Vanlauwe, 2004). From the 2000s, the ISFM paradigm has also evolved towards a more holistic approach beyond soils to more integrated natural resources management (INRM) which specifically recognizes the critical importance of participatory approaches and markets as its key pillars (Sayer and Campbell, 2001).

Agricultural research and development have now recognized the need for a market driven, market-led research. Growing evidence and experience indicates that sustaining success in productivity-based agricultural growth, and adoption of ISFM technologies critically depends on expansion of market opportunities (Diao and Hezel, 2004; Gabre-Madhin and Haggblade, 2004; Haggblade, 2004) and requires thinking beyond productivity to incorporate profitability and competitiveness. In particular, it is argued that without well functioning markets, farmers will not have incentives for investments in ISFM (Debrah, 2004).

It is now increasingly evident that smallholder farmers' key concern is not only agricultural productivity and household food consumption, but also increased income to take care of their multiple aspirations and livelihood needs that need cash. African small-scale farmers need research that will produce options to intensify the use of their limited resources and move into the market economy while maintaining food security (FARA, 2004). Enhancing the ability of smallholder, resource-poor farmers to access market opportunities, and diversify their links with markets is one of the most pressing development challenges facing both governments and non-governmental organizations (IFAD, 2001; IFPRI, 2002; Kindness and Gordon, 2002). Linking farmers to growth markets, and linking technology development to market opportunities

is therefore an important strategy for improving the adoption and impacts of agricultural technologies.

This paper examines the "market-led hypothesis". This hypothesis states that without better access to markets, farmers' adoption of ISFM technologies will remain limited. Therefore, to foster adoption, it is important to identify market opportunities and to link farmers to more profitable markets. It is therefore hypothesized that better access to market opportunities will provide incentives for re-investment in, and adoption of ISFM technologies. This market-led hypothesis using empirical data from selected sites in Malawi, Uganda and Tanzania, and secondary data from Kenya and other parts. The paper also outlines a novel approach to ISFM research—the resources-to-consumption framework which emphasizes forward and backward linkages between resources, production, markets, consumption and re-investment into improving the resource base.

The rest of the paper starts with a description of the research setting and methodology for the study. The sections that follow present the empirical results of re-investment priorities by different categories of farmers and market access. This provides data for testing the market-led hypothesis. The paper concludes with some implications for market led ISFM research and development and highlights the key issues for conducting demand-driven and market-led ISFM research.

Materials and methods

Research setting and context

Data for this paper come from empirical studies and action research conducted in selected sites of Malawi (Kasungu, Dedza and Ukwe); Uganda (Kabale and Tororo), and Tanzania (Lushoto), where CIAT (Spanish acronym for the International Centre for Tropical Agriculture) and its national agricultural research and extension services, and development partners are developing and refining participatory approaches for empowering rural communities to identify market opportunities and develop integrated agroenterprises, generate and access technologies and knowledge through experimentation, and farmers' organizations. This approach termed "Enabling Rural Innovation" is also expanding to other areas, institutions and countries in eastern, southern and central Africa (Sanginga et al., 2004a).

The selected sites in the three countries are characterized by high population density, with poor to moderate access to markets and different poverty levels (Table 1).

Table 1. Description of research sites

	Uganda	Malawi	Tanzania
Altitude (m)	1800	1660	1300
Rainfall pattern/mm	Bimodal/1000–1500	Unimodal/800	Bimodal
Population density (persons/km ²)	246	140	High
Market orientation	Moderate	Low	High
Access to roads	Good	Good	Moderate
Level of absolute poverty	Moderate	High	Moderate
Major causes of poverty	Small farm size, poor soil fertility, environmental degradation, low prices for agricultural produce	Poor soil fertility, drought, low agricultural production	Low prices for agricultural produce, lack of market information
Pilot sites	Kabale and Tororo	Dedza, Ukwe and Kasungu	Lushoto
Number of villages	5	6	3

In all three sites, agriculture was the predominant economic activity. Farmers in Lushoto, Tanzania had the most diverse portfolio of crops, including at least seven crops grown exclusively for sale. By contrast, in Uganda and Malawi, farmers grew some crops mainly for subsistence, many for both consumption and sale and only relied on one or two crops exclusively for cash. Crop productivity was generally low due to low soil fertility, small land holdings, diseases and pests, low input use and adverse climatic conditions. Malawi has a unimodal rainfall pattern (800 mm) with a single growing season and a long dry season that spans 7–8 months (April to October).

The picture that emerges from the three countries is one of varying levels of poverty across and within sites. Of the three sites, farmers in Lushoto, Tanzania were relatively better off, enjoying the highest annual agricultural income (\$149). Poverty was most acute in Dedza and Ukwe, Malawi, while Kabale and Tororo in Uganda represent a situation of moderate poverty.

Data collection and analysis

The data come from three main complementary sources. Two cross-sectional baseline surveys conducted in 2002 and 2004. The first baseline surveys covered a total of 269 households in the initial sites of Kabale in Uganda, Lushoto in Tanzania, and Dedza in Malawi (David, 2003). The second set of baseline surveys conducted in 2004 covered a stratified sample (by gender and wealth categories) of 203 households in two new villages in Kabale and Tororo in Uganda, and 210 households in Ukwe and Kasungu in Malawi. The

baseline studies were designed using the sustainable livelihood framework focusing on farmers' livelihood assets and livelihood strategies. The second source of data comes from monitoring and evaluation of communities and households involved in a participatory action research on linking farmers to market opportunities and rural agroenterprise development. The monitoring and evaluation system focused on incomes generated, use of income and farmers' investment behaviors, and adoption of ISFM technologies. These primary data are enriched with results of other studies and literature from Kenya and other parts of Africa. Data analysis is primarily descriptive and qualitative at this stage, comparing investment priorities and use of ISFM technologies across gender, location and wealth categories.

Operational framework for linking ISFM to market opportunities

The conventional framework for linking farmers to markets has been the commodity chain or production to market system. The decisions on what products and enterprises to develop, what markets to target are often prescribed by government agencies, private companies or development organizations, and then work down the market chain to organize production to meet identified market demands (Bernet et al., 2005; Jones et al., 2002). Rather than promoting the production of a specific commodity and the adoption of a specific ISFM package, the resources-to-consumption (R-to-C) uses participatory approaches to identify market opportunities and enable farmers to make their own decisions, invest their own

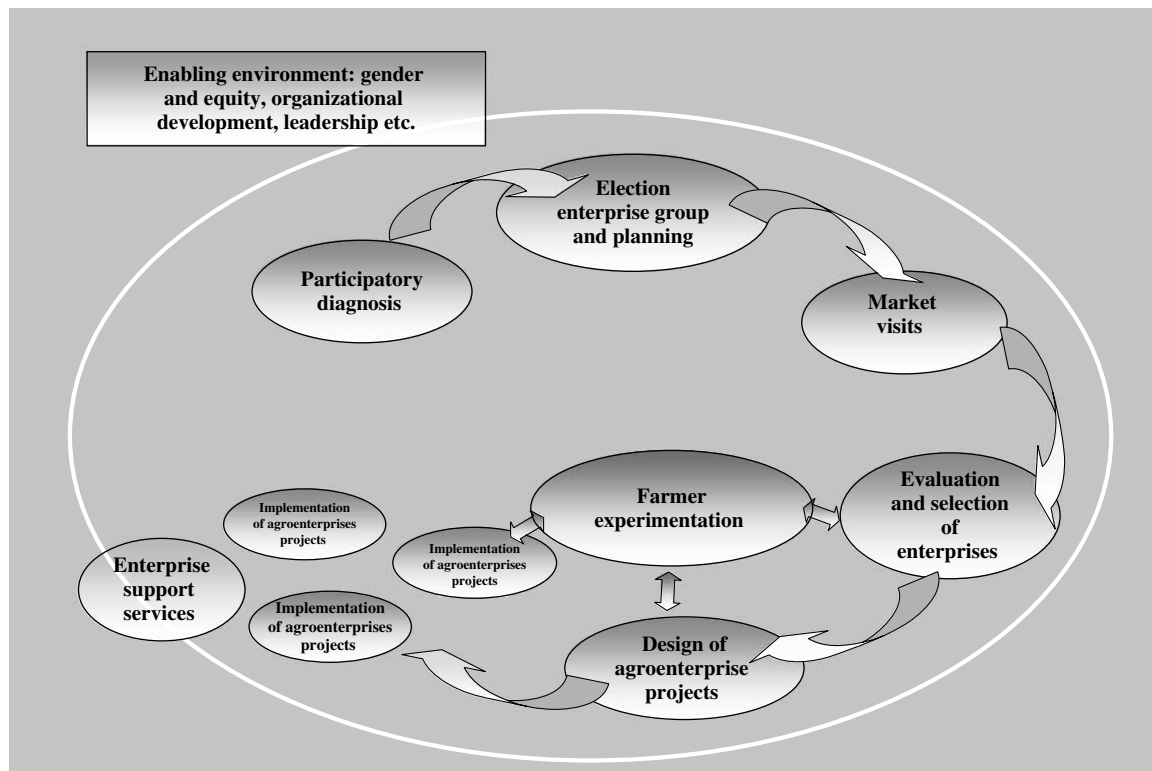

Figure 1. Procedure for participatory market research and market opportunity identification

resources and resolve their own problems through experimentation. This is a community-based approach in which rural communities become active partners in processes of identifying market opportunities and developing profitable agroenterprises (Sanginga et al., 2004a, b). It is based on a territorial approach to agroenterprise development (Ortestag, 1999; Lundy et al., 2003), in which the enterprise options are selected by rural communities based on their assets and opportunities.

The R-to-C framework extends the commodity chain to include investment in natural resource management (Figure 1), and specifically links ISFM to market opportunities. It strengthens forwards and backwards linkages between natural resource management, agriculture production and markets (Kaaria and Ashby, 2001). More specifically, the R-to-C framework links farmer participatory research, market opportunity identification, and strengthening farmers' capacity to better manage their resources (natural, social, human, financial, and physical). It is based on the premises that strengthening community-level management skills and human capacity can increase the

opportunities for small-scale farmers to benefit from market participation, and also facilitate the adoption of technologies (Bingen et al., 2003).

Results and discussion

Participatory Market Research and Market Opportunities Identification

The Enabling Rural Innovation (ERI) approach uses participatory market research as a starting point for research. This is a community-based approach in which rural communities become active partners in processes of identifying market opportunities and developing profitable agroenterprises. The market opportunity identification stage aims to strengthen the capacity of farmers to identify, evaluate and select a basket of options that a) an identified market demand, b) can be produced in the region, and c) are of interest to the farmers and other producers. The goal is to create an entrepreneurial culture in rural communities, whereby

farmers produce what they can market rather than trying to market what they produce. An important step of the participatory market research process is therefore to conduct market visits to broaden farmers' minds and present new opportunities in order to assess demands of products in short supply and products in high demand that can be produced by the community. However, the evaluation of a portfolio of options to achieve balanced objectives for profitability, sustainability and equity is strategic to balance income generation and food production needs of farmers (Sanginga et al., 2004a).

Table 2 summarizes the different enterprises options selected in the different pilot learning sites. Results show that farmers tend to select existing crops (beans, groundnuts, potatoes) and small livestock (goats, pigs, poultry and rabbits) for which they have good knowledge of production, for both old and new markets. However, increasingly, farmers are beginning to select relatively new enterprises for new and old markets as well.

Linking ISFM to market opportunities through farmer experimentation

Producing for the market is inherently more risky than producing crops for one's own consumption. Farmers need new skills to increase their competitiveness in the markets (Hellin and Higgmann, 2001). This is critical because there is a risk that market-oriented production system is likely to lead to more intensive production and could place further pressure on an already fragile resource base (for example, by increasing soil fertility depletion and soil erosion, increasing diseases and pests, etc.) which can eventually limit the potential for household to sustain production, and may lead for further degradation of natural resource base. Some studies have shown that farmers will continue to deplete soil nutrients as long as the land provides them with sufficient cash. For example, using data from Kenya, Smaling et al. (1997) reported that a high degree of market orientation correlated negatively with the N and K balance. Wortmann and Kaizzi (1998) found that nutrient balances on banana production in Uganda are negative. They concluded that harvested products contribute more to negative balance, while erosion has far less impact.

Although the more market-oriented farmers may import nutrient through fertilizer and other ISFM practices, the amount is insufficient to compensate for the outflows through marketed products, erosion, and

leaching. However, evidence from other regions of the world shows that commercial farmers have averaged net positive nutrient balances (Smaling et al., 1997). In the famous Machakos case of "More people, less erosion", the authors provide a case of environmental recovery where better access to profitable markets led to investments in natural resources management, intensification of production and adoption of improved agricultural technologies, rather than accelerating the degradation of natural resources and soil mining.

Across sites, a key constraint to crop productivity and to increasing profitability was declining soil fertility. At the same time, there are a number of ISFM technologies but their adoption remains limited. Braun et al. (1997), Snapp et al. (2003) and others have critiqued continued use of blanket high dose fertilizer recommendations, and called for research and extension efforts to build farmers' capacity to maximize returns to their limited resources, land, labor and capital, from smaller more affordable input purchases. Bekunda and Bationo (1997)'s review of soil fertility research in Africa concluded that the lack of adoption is poor farmer participation, and poor representation of farmers' conditions in soil fertility trials. There is now a large body of literature that indicates that farmer participatory research (FPR) is vital for reorienting technology development, accelerating adoption and creating wider impacts of agricultural technologies in small-scale farming (Johnson et al., 2003; Ashby, 2003; Defoer et al., (2000); Veldhuizen, (1997); Pretty and Hine, 2001). Recently, Anderson (2003) documented a number of emerging success in ISFM in Africa which indicate that significant progress is possible with participatory approaches to NRM.

The R-to-C approach emphasizes incorporating client-oriented participatory research methods into very early stages of technology design. Farmer experimentation provided farmers with opportunities for trying out a range of options to solve constraints in production, to adapt them to their situations and circumstances, build local capacity to find solutions to production problem and to evaluate the profitability of different ISFM technologies in order to improve their decision making concerning input use. Based on the results of participatory market research and evaluation of enterprise options, farmers were facilitated to carry out an agronomic evaluation matrix to identify constraints in production, and identify opportunities for increasing the productivity of the selected enterprises. This agronomic characterization matrix provided an opportunity for stimulating farmers' experimentation

Table 2. Different enterprise options selected by farmers in Malawi, Uganda and Tanzania and types of experiments for the selected enterprises

Enterprise Options	Issues for experimentation	Sites/Countries
Potatoes	Small plot seed production Integrated pest and diseases management Participatory varietal evaluation Integrated soil fertility management	Ukwe, Malawi Kabale, Uganda
Beans	Integrated soil fertility management Integrated pest and diseases management Participatory varietal selection Seed multiplication, seed systems Intercropping	Hai, Tanzania Lushoto, Tanzania Dedza, Malawi Tororo, Uganda Ukwe, Malawi
Pyrethrum	Integrated soil fertility management Soil and water conservation	Kabale Uganda
Goats	Evaluation and selection of multipurpose legume trees and forages	Kabale, Uganda Dedza, Malawi Ukwe Malawi
Pigs	Dual purpose legumes (Intercropping pigeon peas and soybeans with maize; crop rotation soybean and maize, pigeon peas and maize) for supplement feedings Participatory varietal selection of pigeon peas and soybean Farmer field school on different feeding regimes, health and management practices	Ukwe, Malawi
Tomatoes, onions, garlic, zucchini, ginger,	Integrated soil fertility management Integrated pest and diseases management Variety evaluation	Hai, Tanzania Lushoto, Tanzania Hoima Mukono, Uganda

process to test alternative production strategies that would allow them to sustain more intensive, market-oriented production, and overcome production constraints. This phase was also necessary to reduce risks of new enterprises, and to maintain the balance between food security and market orientation.

In the different sites, integrated soil fertility management experiments conducted by farmers' groups in support of their enterprise options include:

- 1 Management options better suited to different soil conditions (poor soils, acid soils, clay soils) different locations within the landscape
- 2 Appropriate use of organic/inorganic materials for soil fertility improvement
- 3 Management options aiming at optimal use of legumes in combination with strategic applications of organic and inorganic fertilizers to maximize nutrient cycling and soil organic matter replenishment
- 4 Appropriate niches for legume for soil fertility improvement and erosion control

5 Testing and evaluation of dual purpose grain legumes (soybean, pigeon peas, ad green manure)

Preliminary results from the pilot sites show that the use of improved ISFM technologies increased the productivity and competitiveness of agro-enterprises. We illustrate this with a case from Kabale, Uganda where, through a participatory process of market opportunity identification, a group of farmers were linked to a more profitable and competitive market in Kampala. The market, a fast food restaurant, Nandos, requires large sized oval shaped potatoes with few eyes so as to reduce losses on peeling, oil absorption on frying, and to have more palatable chips. Meeting these quality requirements has been a constant challenge to farmers whose popular potato variety and management practices result in the production of potato of different sizes and shapes, higher rate of deterioration after harvest, and subsequent higher losses on storage. Initially, only 20 to 60% of the harvested potatoes could satisfy the quality requirements of Nandos. The challenge was therefore to modify production and management practices to be able to supply quality potatoes throughout the year.

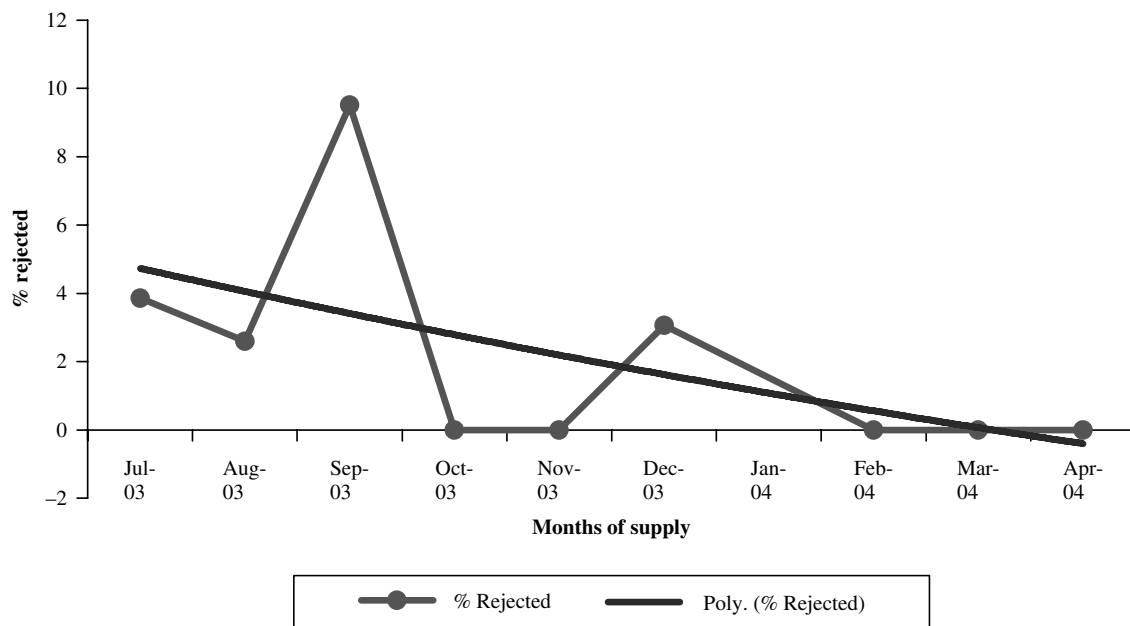

Figure 2. Reduction in potatoes rejects due to better agronomic practices in Nyabyumba, Uganda

Through a process of farmers' experimentation for optimising production and management practices, particularly fertiliser use, pest and disease management, and other agronomic practices (spacing, planting density, weeding), the level of rejects has been considerably reduced to minimal levels (Figure 2). The productivity and competitiveness of the potato enterprise increased significantly to the levels that farmers were able to make significant profits and routinely invest in purchasing fertilizers. The crop has considerable room for improvement as it responds very well to fertilizer (Ferris et al., 2002). Some farmers were spending up to U Shs 340,000 (US\$ 197) on fertilizer a year.

Results from other pilot sites show that the use of ISFM significantly increased yields and quality of products. In Malawi farmers using fertilizer and better management practices produced 1.9 t ha⁻¹ of beans compared to only 535 kgs on non-fertilized plots. Snapp et al. (2003) also reported that farmers who applied fertilizer had 105% more yields, and 21–42% more profits than those of a control group of comparable good farmers in the same area. Similar results were found on bean enterprises in Tororo, Uganda and Kasungu in Malawi, as well as Pyrethrum in Kabale, Uganda. In all these cases, higher rates of returns were recorded where ISFM options were used.

The Machakos case also showed that research and development organizations have an important role to

play by increasing access to sources of knowledge and technologies, and building farmers' capacity to evaluating and adapting technologies, rather than disseminating blanket recommendations or "best-bet" technology package an important factor for environmental recovery, it was important to provide a basket of options from which farmers can test, evaluate, select and adapt them based on their circumstances and needs (Tiffen et al., 1994). There are several other examples of increasing profitability and economic returns of several ISFM technologies. Sanchez et al. (1997) give evidence of profitability of soil replenishment in three contrasting cases where net farm incomes increased by 80–160%. In Malawi (Snapp et al., 2003) found that legume intensification increased yields by approximately 40% with a net benefit increase of US\$50 ha⁻¹. Sanginga et al. (2001) showed that the residual effects of soybean on a cereal crop are often dramatic and fertilizer use to a subsequent cereal can be cut by 50%. Their use in rotation with cereals have shown high net benefits and returns (1,450 US\$). Several other studies have shown evidence of positive economic returns of diverse soil fertility technologies (Woomer, 2004; Groot, 2004).

Farmers' Re-Investment Priorities

Investing in ISFM, and particularly fertilizer use requires financial commitments by farmers (Snapp

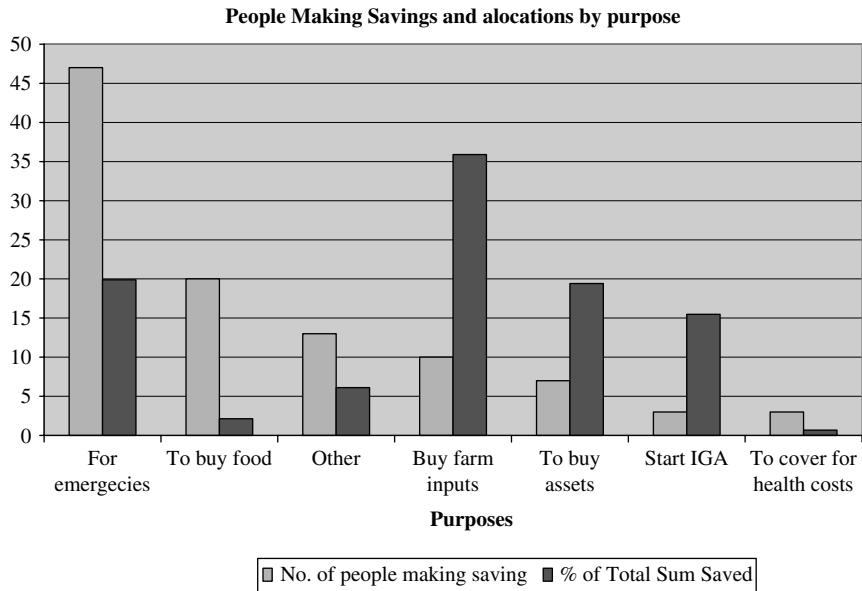

Figure 3. Percentage distribution of income (savings and credit) allocation and proportion of income allocated to different needs of the poor in Malawi

et al., 2003), and income to invest in improving the productivity of market oriented crops. The studies investigated how farmers used their income, their expenditures and investment priorities. Results of wealth ranking exercises (Gradin, 1988) distinguished three broad categories based on locally and socially defined indicators of well-being. Although there exists some differentiation among wealth categories based on productive resources and other assets, the production conditions of farmers are generally similar (fragmented small land sizes, access to markets, poor infrastructures).

Analysis of farmers' investment priorities revealed interesting results with significant differences between sites, wealth categories and gender groups (Table 3). In Malawi purchasing agricultural inputs (mainly fertilizer and seeds) ranked highly as a first to second investment priority for both men and women across wealth categories, followed by investing into small business and in small livestock. In Tanzania, the majority of men ranked agricultural inputs as a second to third priority after house improvement, and livestock. On the contrary, for the majority of women across all wealth categories, investing in agricultural inputs was clearly not even in their first five priorities. Similarly, in Uganda, the first investment priorities for the majority of farmers across wealth categories and gender was buying or renting more fertile land, investing in livestock, paying school fees and buying clothes.

Investment in agricultural inputs was marginally considered as a third priority by poor male farmers, after land and livestock. This contrasts with Malawi, where poor farmers also reinvested in purchasing fertilizers, and allocated the highest proportion of their income (savings and credit) to purchasing fertilizer (Figure 3)

However, monitoring survey results and observations are consistently showing that farmers are able to invest in fertilizer for crops that have good market opportunities. In Uganda despite these low levels of investments in purchasing fertilizers, the Nyabyumba farmers groups who are supplying potatoes to Nandos, a fast food restaurant in Kampala, are using more soil erosion control measures on their potatoes plots compared to other farmers planting potatoes but not linked to a more profitable market. On average, the more market oriented male farmers have dug more trenches on their potatoes plots (Figure 4), compared to farmers in the other three villages who did not have market access. Because of its high labor demand, but also because of the market opportunity, it is not surprising that more male farmers are involved in soil conservation measures, compared to women. This is interesting as it is well established that men are less involved in agricultural activities in Kabale district.

Similarly, the Muguli B and Karambo farmers who were linked to a Pyrethrum market were also found to improve their soil conservation measures when

Table 3. Investment priority scores (average) by wealth categories and gender in selected sites

Investment areas	Wealth categories					
	Wealthy		Average		Poor	
	M	W	M	W	M	W
<i>Kabale, Uganda (men n = 44; women n = 90)</i>						
Savings	1.00	1.00	0.38	0.29	0.17	0.37
Off-farm business	0.80	0.60	1.44*	0.97*	0.70	0.35
Improve housing	0.80	1.60*	0.13	0.74	1.09	0.94
Livestock	1.20*	1.20	1.56**	0.68	2.17**	1.41**
Buying/renting land	2.40***	2.20***	2.06***	1.74	2.35***	1.90***
Purchasing food	0.40	0.40	0.19	0.62	0.57	1.06
Agricultural inputs	0.60	0.20	0.38	0.56	1.13*	0.61
Buy clothes	0.80	1.60*	0.63	0.97	0.61	1.18*
School fees	1.60**	1.60**	0.63	0.65	0.39	0.45
Other	0	0	0.63	0.24	0.17	0.51
<i>Dedza, Malawi (men n = 83; women n = 113)</i>						
Savings	0.76	0.57	0.41	0.74	0.58	0.79
Off-farm business	2.29**	2.43***	2.00**	1.89	2.75***	2.51***
Improve housing	0.81	0.48	0.53	0.68	0.44	0.15
Livestock	1.19*	1.22	1.06*	0.68	1.36*	0.85
Buying/renting land	1.00	1.00	0.12	0.21	0.78	0.53
Purchasing food	0.81	0.70	0.18	0.53	0.81	1.34*
Agricultural inputs	2.43***	2.00**	3.47***	3.26	1.94**	1.87**
Buy clothes	1.05	1.26*	0.53	1.05	0.81	1.02
School fees	0.38	0.30	0.47	0.47	0.19	0.23
Other	0.33	0	0.18	0.21	0.47	0.23
<i>Lushoto, Tanzania</i>						
Savings	0.53	1.0	0.72	0.72	0.50	1.00*
Off-farm business	0.84***	1.29*	1.18*	0.84	1.33	0.29
Improve housing	2.11	1.10	2.0	1.74***	2.50***	0.71
Livestock	1.26	1.90***	1.26***	1.72**	1.67**	0.71
Buying/renting land	1.63*	1.05	1.10	1.08	1.17	1.00
Purchasing food	0.42	0.78	0.77	0.90	1.17	1.86**
Agricultural inputs	1.74**	0.52	1.23**	0.48	1.50*	0.86
Buy clothes	0.37	0.81	0.31	1.10*	1.00	2.00***
School fees	1.0	1.33**	0.90	0.54	0.50	0.86
Other	0.21	0	0.23	0.04	0	0

Investment priorities were scored using a 4 scale points (0 to 3, with 3 being the score for the first priority); *** High priority, ** Medium priority, * low priority.

pyrethrum was being sold. They also preferred small quantities of inorganic fertilizer compared to farm yard manure, despite a relatively high cost of acquiring these fertilizers. This enthusiasm has waned off since the market for pyrethrum collapsed and farmers are increasingly abandoning their soil conservation measures.

These results also revealed positive correlations between fertilizer use and wealth categories of farmers. These results are consistent with other studies that also reported that wealthy farmers frequently used mineral fertilizer, spending on average USD 102 on farm

inputs, compared to only USD 05 for poor farmers (Place et al., 2002). Debrah (2003) gives examples of promising marketing systems that provide incentives for adoption and use of ISFM technologies. These include the market gardens in Lome, Togo where small-scale farmers apply several hundreds kilograms of chemical fertilizers and over 10 tons of manure to improve the structure and fertility of the soil for increased and sustainable production of vegetable. In the famous Machakos case of "More people, less erosion", Tiffen et al. (1994) the authors provide a case of environmental recovery where better access

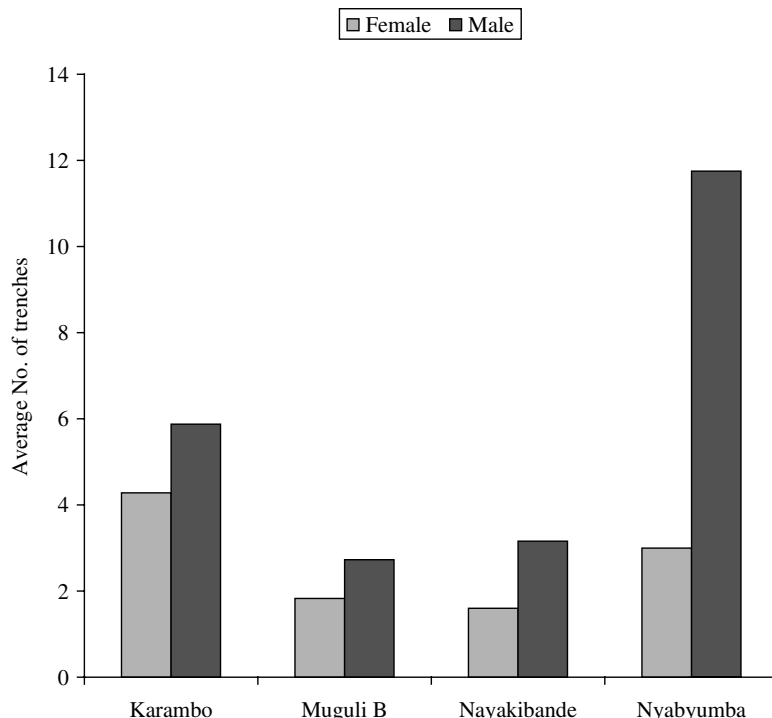

Figure 4. Average number of trenches dug by male and female farmers in Kabale, Uganda

to profitable markets led to investments in natural resources management, intensification of production and adoption of improved agricultural technologies, rather than degradation of natural resources and soil mining.

Expanding inputs availability

Across sites, virtually all farmers (97%) reported problems accessing fertilizers, due to high price and lack of markets. Other important marketing constraints identified by farmers included lack of information on types and rates of application; lack of retail fertilizer shops within their villages and transport facilities. It can therefore be argued that the low use of mineral fertilizer is essentially due to structural constraints, rather than farmers' inherent behavior. Increasingly, several scholars are advocating for increased fertilizer use in Africa as a core strategy to restore soil fertility. Several views now concur with Quinones et al. (1997) conclusion that attention must be given to improving the efficiency of supply and transport of fertilizer to make them more affordable to farmers.

In their recent article on expanding access to agricultural inputs in Africa, Kelly et al. (2003) found that further expansion of input use is often constrained by inadequate investment in a variety of public goods needed to stimulate input-led agricultural intensification. They argued that unless efforts are made to significantly increase fertilizer use and adoption of fertilizer responsive technologies, productivity and income growth will remain low. Given the large number of small holder farmers who use fertilizers at low rates, more research and extension efforts are needed on ways to maximize response and profitability of small amounts of fertilizer (Snapp et al., 2003), to enhance fertilizer efficiency, targeting and profitability.

Improvement of accessibility of fertilizers and other inputs should focus mainly on packaging of fertilizers into small packets to increase affordability. There are many experiences across Africa that give evidence of cases of expanding fertilizer use in Africa. Kelly et al. (2003) expand on experience with the Sustainable Community Development Programme (SCODP) in Kenya that undertook to expand fertilizer use among poor farmers in Western Kenya. The SCODP approach was characterized by efforts to increase farmers' awareness of modern inputs, blending and packaging of fertilizer

into affordable mini-packs, and a distribution network of rural stockists to improve availability. The impressive results of this approach led to increased physical and financial access to fertilizer by some 50,000 Kenya poor farmers. Similar initiatives are spreading in Uganda and Kenya, and other parts of Africa. In Malawi, there is also evidence that the starter pack programme permitted increased fertilizer use at farm level.

Responses to such programmes are striking and give positive or better than double return to agricultural investment. Groot (2004) and Bationo (pers. Comm.) reported that combination of micro-dosing with complementary institutional and market linkage has led to a significant technology breakthrough in Niger. In just 3 years, a total of about 5,000 farm households in 20 pilot sites have started fertilizer micro-dosing and are producing 100% more food, and have increased farm incomes 50% on average. Some NGOs are actively disseminating fertilizer sales in very small packets (100g) in western Kenya and Uganda. These programmes provide evidence that effective demands for inputs can be developed among poor farmers if the availability, accessibility and affordability constraints can be removed. However, as observed Snapp et al. (2003) substantial growth in fertilizer use is unlikely unless barriers faced by smallholder farmers in accessing fertilizers and other inputs are addressed.

Strengthening farmers' organizational capacity

One critical success factor in linking farmers to markets has been the presence of mature farmers' organizations (GFAR, 2002) or mature social capital. Mature social capital, as expressed in strong farmers' organizations, increases economies of scale, and can also facilitate access to micro-credit, market information and other support services from a variety of stakeholders who now operate through organized groups. As summarized in a recent World Bank paper (cited in Bingen 2003: 407), "*producer organizations amplify the political voice of smallholder producers, reduce the cost of marketing of inputs and outputs, and provide a forum for members to share information, coordinate activities and make collective decisions. Producers' organizations create opportunities for producers to get involved in value-adding activities such as input supply, credit, processing, marketing and distribution*"

Farmers' organizations have also the capacity to reduce farm-level transaction costs of inputs acquisition while simultaneously reducing transaction costs

for potential input suppliers and output buyers (Kelly et al., 2003; Bingen et al., 2003). They are also critical as a mechanism for promoting uptake and upscaling of ISFM technologies and innovations. They also provide opportunities for women and poor farmers who can participate in market through organized groups. Strong farmers' organizations can be critical to help protect the terms of trade for small-scale farmers and increase their bargaining power. They help facilitate critical market functions such as assembly, grading and standardization, storage, processing, transport, contracting, market information, arbitrage, wholesaling, and distribution (Ferris et al., 2002; FARA, 2004). Recent research in southwestern Uganda has also shown that strengthening social capital is critical for influencing policy change and formulating effective byelaws and community processes which facilitate the adoption of NRM innovations (Sanginga et al., 2004c).

Conclusion

The paper is based on the premise that the principal constraint to adoption and widespread impact of soil fertility research is not so much a lack of scientific excellence or expertise, or technologies but rather the failure to integrate soil fertility management research across disciplines, and particularly by not linking ISFM research to market opportunities. The key hypothesis for market-led ISFM hypothesis is that better market opportunities will provide incentives for farmers to invest in ISFM technologies. This market-led hypothesis is increasingly becoming a key pillar of ISFM research (TSBF, 2005) and other areas of integrated agricultural research for development.

The studies from which this paper is based show mixed results, and caution unguided generalizations. While there is evidence that more market-oriented farmers are able to invest their additional income in ISFM technologies, we found that there are significant variations across areas, countries, crops, gender and wealth categories. In a considerable number of cases, reinvesting in agricultural inputs and soil fertility replenishment was a lower priority compared to other livelihood needs such as paying school fees, health care, nutrition, food security, business investments, housing, and savings.

However, empirical evidence in Uganda and Malawi shows that farmers receiving higher incomes due to improved marketing opportunities are practicing improved natural resource management, controlling

soil erosion and purchasing of inorganic fertilizers. However, as shown in this paper, soil fertility investment is not the sole preoccupation of resource poor farmers. Their livelihood needs are varied and complex. The resource-to-consumption approach needs to be expanded to include important issues such as health, nutrition, education, and other livelihood assets. An important dimension of market-led ISFM should also consider influencing policy change as it was shown that government policies are instrumental in providing incentives and institutions that increase farm-gate profitability, increase availability and profitability of inputs, and increase people's ability to engage in marketing and develop sustainable agroenterprises.

These results are still exploratory. There are still a number of unanswered questions that need to be investigated in further testing the market-led hypothesis which is increasingly becoming a key research strategy in many national and international research organizations. Such questions may include:

1. Where and under what conditions does market orientation lead (or not) to increased investments in ISFM and improved livelihoods?
2. Which ISFM innovations are more appropriate and profitable to different categories of farmers and market affiliation
3. What are the resources, assets and conditions that are necessary to motivate farmers, especially women and the poor to further invest in ISFM?
4. What policy incentives and institutional innovations are needed to make markets work for the poor, women, and vulnerable?
5. What are the links and trade off between market-orientation, food security, health, gender and equity?

Adopting the R-to-C approach does not require soil scientists to become experts in marketing, or social scientists. The core role of scientists should remain to be at the forefront of cutting edge ISFM technology development for intensifying smallholder farming systems. However, they need to understand markets and marketing concepts, and start thinking about approaches for mainstreaming market-led research in ISFM. With the emergence of this broader agenda for ISFM research, coupled with the shirking resources base for agricultural research organizations (Alston et al., 1995; Marthur and Gaiha, 2003), the need to engage with new stakeholders and building strategic partnerships is critical for mainstreaming market-led and demand driven research to enhance the adoption

and impacts of ISFM research on people's livelihoods. Tackling market-led ISFM research and development thus requires a holistic, multi-institutional and transdisciplinary systems approach by a range of research and development organizations. In their much acclaimed book on soil fertility replenishment in Africa, Sanchez et al. (1997) concluded that a soil fertility strategy for Africa must effectively address well known constraints in a novel way. This paper suggests that the resource-to-consumption approach offers prospects for a different type of research to addresses the full chain of interactions, from resources to production, marketing and consumption, and investments into natural resource base and other livelihood assets.

Acknowledgement

We thank two anonymous reviewers for their comments and suggestions that helped to improve the paper. Financial support from the Belgian Directorate of International Cooperation and the Canadian International Development Agency (CIDA) is acknowledged.

References

- Alston J.M., Norton G.W. and Pardey P.G. 1995. *Science under scarcity: principles and practice for agricultural research evaluation and priority setting*. Cornell University Press, Ithaca, N. Y, USA.
- Anderson J. 2003. Nature, Wealth, and Power in Africa: *Emerging best practice for revitalising rural Africa*; Discussion draft. Washington: USAID.
- Ashby J.A. 2003. *Uniting Science and Participation in the Process of Innovation-research for development*. Pp. 1–19. In: Pound B., Snapp S., McDougall C. and Braun A. (Eds.) 2003. *Managing Natural Resources for Sustainable Livelihoods. Uniting Science and Participation*. London: Earthscan Publications and the International Development Research Centre.
- Bationo A. (ed). 2004. *Managing Nutrient Cycle to sustain soil fertility in sub-Saharan Africa*. Academy Science Publishers, Nairobi-Kenya. Pp 25–42.
- Bationo, A., Waswa, B; Kihara, J; and Kimetu, J. (2006). Advances in integrated soil fertility management in sub-Saharan Africa: Challenges and Opportunities. *Nutrients Cycling in Agro ecosystems* 76 (2-3): 109–381
- Bekunda M and Bationo A. 1997. Soil fertility Management in Africa: A review of selected research trials. Pp. 63–79. In: Buresh R.J., Sanchez P.A., and Calhoun F. (eds.) *Replenishing soil fertility in Africa*. SSSA Special publication Number 51. Madison, USA.
- Bernet, T., Devaux, A., Ortiz, O. and Thiele, G. 2005. Participatory Market Chain Approach. In Gonsalves, J., Becker, T., Braun, A., Campilan, D., De Chavez, H., Fajber, E., Kapiriri, M., Rivaca-Caminade, J. et R. Vernooij (dir.), 2005, *Participatory*

- research and development for sustainable agriculture and natural resource management*. Laguna (Philippines), Centre international de la pomme de terre, *Users' Perspectives with Agricultural Research and Development*/Ottawa.
- Bingen J., Serrano A., Howard J. 2003. Linking farmers to markets: different approaches to human capital development. *Food Policy* 28: 405–419.
- Braun A., Smaling E., Muchugu E., Shepherd K.D. and Corbett 1997. Maintenance and improvement of soil productivity in the highlands of Ethiopia, Kenya, Madagascar and Uganda. AHI Africa Technical Report Series no6. African Highlands Initiative. Nairobi, Kenya.
- Buresh R.J., Sanchez P.A. and Calhoun F. eds. 1997 Replenishing soil fertility in Africa. SSSA Special publication Number 51. Madison, USA.
- David S. 2003. Poverty and rural livelihoods in Uganda, Malawi and Tanzania. CIAT Occasional Publication series no 41, CIAT, Kampala, Uganda.
- Debrah K. 2004. Sustainable marketing systems to support integrated natural resources management. Pp. 87–196. In FARA (Forum for Agricultural Research in Africa). 2004. *Building Sustainable Livelihoods through Integrated Agricultural Research for Development. Securing the future for Africa's children*. Volume 2. Sub-Saharan Africa Challenge Programme Submitted to the Interim Science Council of the Consultative Group on International Agricultural Research, August 2003.
- Defoer T., Kante S., Hilhorst T. and de Groot de H. 2000. Managing soil fertility. A resource guide for participatory learning and action research. Royal tropical Institute, Amsterdam.
- Diao X. and Hazell P. 2004. Exploring market opportunities for African smallholders. Paper prepared for the 2020 Africa Conference "Assuring food security in Africa by 2020: Prioritizing actions, strengthening actors, and facilitating partnerships. Kampala, Uganda. April 1–3, 2004.
- FARA (Forum for Agricultural Research in Africa). 2004. Building Sustainable Livelihoods through Integrated Agricultural Research for Development. Securing the future for Africa's children. Volume 1. Programme Proposal. Sub-Saharan Africa Challenge Programme Submitted to the Interim Science Council of the Consultative Group on International Agricultural Research.
- Ferris R.S., Okoboi G., Crissman C., Ewell P. and Lemega B. 2002. Performance and growth prospects of Irish Potatoes as a component of the development of strategic exports in Uganda. ASARECA/IITA Monograph 2. IITA Ibadan, Nigeria. 44pp.
- Gabre-Madhin E. and Haggblade S. 2004. Successes in African Agriculture: Results of an Expert Survey. *World Development* 32(5): 745–766.
- GFAR (Global Forum on Agricultural Research) 2002. Strengthening the Participation of Farmers' Organisations and of NGOs in Global Agricultural Research for Development (ARD) Rome, February 2002.
- Giller K.E. 2001. Nitrogen fixation in tropical cropping systems. 2nd edition. CABI Publishing, Wallingford, Oxon, U. K.
- Gradin B. 1988. Wealth ranking in smallholder communities: A field manual. London: intermediate technology publications.
- Groot J. 2004. From thousands to millions; accelerating agricultural intensification and economic growth in sub-Saharan Africa, through partnerships and market development. Paper presented at the African Network for Soil Biology and Fertility (AFNet) International symposium on improving human welfare and environmental conservation by empowering farmers to combat soil fertility degradation symposium, Yaoundé, Cameroon , May 17–21.
- Haggblade S. 2004. Building on success in African Agriculture. International Food Policy Research Institute. 2020 Focus 12.
- Hellin J. and Higgmann S. 2001. Competing in the markets. Farmers need new skills. *Appropriate technology* 28 (2): 5–7.
- IFAD (International Fund for Agricultural Development). 2001. *Rural poverty report 2001: The challenge of ending rural poverty*. Rome, Italy: (IFAD). www.ifad.org/poverty/index.htm.
- IFPRI (International Food Policy Research Institute). 2002. Cutting hunger in Africa through smallholder-led growth. <http://www.ifpri.org/themes/aicha.htm>.
- Johnson N., Lilja N. and Ashby J. 2003. Measuring the impact of user participation in agricultural and natural resource management research. *Agricultural Systems*. 78: 287–306.
- Jones R., Freeman H.A. and Monaco L.G. 2002. Improving the access of small-scale farmers in eastern and southern Africa to global pigeon pea markets. *AgREN. Network paper no 120*.
- Kaaria S.K. and Ashby J.A. 2001. An Approach to Technological Innovation that Benefits Rural Women: The resource-to-consumption system. CGIAR Program on Participatory Research and Gender Analysis (PRGA) for Technology Development and Institutional Innovation. Working Document No. 13.
- Kelly V., Adesina A. and Gordon A. 2003. Expanding access to agricultural inputs in Africa: a review of recent market development experience. *Food Policy* 28: 379–404.
- Kindness H. and Gordon A. 2002. Agricultural marketing in developing countries: The role of NGOs and CBOs. Social and Economic Development Department, Natural Resources Institute, University of Greenwich, London, UK. (Policy Series No 13).
- Lundy M., Gottret M.V., Cifuentes W., Ostertag C.F. and Best R. 2003. Design of strategies to increase the competitiveness of smallholder production chains. Field Manual. Cali, Colombia. Centro International de Agricultura Tropical. Rural Agroenterprise Development Project. 78p. www.ciat.cgiar.org.
- Marthur S. and Gaiha S. 2003. Impact of agricultural research on rural poverty: A review of some analytical issues. Pp. 23–41. In: Marthur S. and Pachico D. (Eds.) 2003. *Agricultural Research and Poverty Reduction. Some issues and Evidence*. Cali, Co. Centro International de Agricultura Tropical. CIAT
- Nandwa SM. 2003. Perspectives on Soil fertility in Africa. In: Gichuru M.P., Bationo A., Bekunda M.A., Goma H.C., Mafongonya P.L. and others (eds.) *Soil fertility management in Africa: A regional perspective*. Academy of Science Publishers, Nairobi Kenya. Pp 2–50.
- Ostertag Galvez C.F. 1999. *Identifying and assessing market opportunities for small rural producers*. Tools for decision-making in NRM. Cali, CO. International Centre for Tropical Agriculture, CIAT.
- Place F., Franzel S., Dewolf J., Rommesle R., Kwesiga F., Niang A. and Jama B. 2002. Agroforestry for soil fertility replenishment: Evidence on adoption processes in Kenya, and Zambia. In: Barret C.B., Place F. and Abdulahi A. (eds.) *Natural resources amangement in African agriculture: Understanding and improving current practices*. CABI, Wallingford, UK, 155–168.
- Pretty J. and Hine R. 2001. Reducing food poverty with sustainable agriculture: a summary of new evidence; final report from the SAFE-World Research Project. University of Essex, Cochester, UK.
- Quinones M.A., Borlaug N.E. and Dowswell C.R. 1997. A Fertilizer-based Green Revolution for Africa. Pp. 81–95.

- Sanchez P.A., Shepherd K.D., Soule M.J., Place F.M., Buresh R.J., Izaac A.M.N., Mokwunye A.Z., Kwesiga F.R., Ndiritu C.G. and Woome P.L. 1997. Soil fertility replenishment in Africa: An investment in natural resource capital. In: Buresh R.J., Sanchez P.A., and Calhoun F. (eds.) *Replenishing soil fertility in Africa*. SSSA Special publication Number 51. Madison, USA.
- Sanginga N., Dashiell K., Diels J., Vanlauwe B., Lyasse O., Carsky R.J., Tarawali S., Asafo-Adjei B., Menkir A., Schulz S., Sing B.B., Chikoye D., Keatinge J.D.H. and Ortiz R. 2003 Sustainable resource management coupled to resilient germplasm to provide new intensive cereal–grain legume–livestock systems in the dry savanna. *Agriculture, Ecosystems and Environment* 100: 305–314.
- Sanginga N., Okogun J.A., Vanlauwe B., Diels J., Carsky R.J. and Dashiell K. 2001. Nitrogen contribution of promiscuous soybeans in maize-based cropping systems. Tian G. Ishida F. and Keatinge J.D.H. (eds), SSSA Special Publication Number 58, Madison, USA, pp 157–178.
- Sanginga P., Kaaria S., Chitsike C., Best R., Delve R. and Kirkby R. 2004a. Enabling rural innovation in Africa: An Approach for Integrating farmer participatory research and participatory market research to build the agricultural assets of rural poor. *U. Journal of Agricultural Sciences* 9 (1): 942–957.
- Sanginga P., Chitsike C., Best R., Delve R., Kaaria S. and Kirkby R. 2004b. Linking Smallholder Farmers to Markets: An approach for empowering mountain communities to identify market opportunities and develop rural agroenterprises *Mountain Research and Development*, Vol 24 (4): 288–291.
- Sanginga, P., Kamugisha, R., Martin, A., Kakuru, A. and Stroud, A. 2004c. Facilitating participatory processes for policy change in natural resource management: lessons from the highlands of southwestern Uganda. *U. Journal of Agricultural Sciences* 9 (1): 958–970
- Sayer J. and Campbell B.M. 2001. Research to integrate productivity enhancement, environmental protection, and human development. *Conservation Ecology* 15 (2) [online] URL: <http://www.consecol.org/vol15/iss2/art1>
- Smaling, E.M.A., Nandwa, S.M., Janssen, B.H., (1997). Soil Fertility in Africa is at stake. In: Buresh, R.J., Sanchez, P.A., Calhoun, F. (Eds.), *Replenishing Soil Fertility in Africa*. Soil Science Society of America, Madison, Wisconsin.
- Snapp S., Blackie M.J. and Donovan C. 2003. Realigning research and extension to focus on farmers' constraints and opportunities. *Food Policy* 28: 349–363.
- Tiffen M., Mortimore M. and Gichuki F. 1994. More people, less erosion. Environmental recovery in Kenya. Overseas Development Institute. Kenyan Edition. ACTS Press, Nairobi Kenya.
- TSBF (Tropical Soil Biology and Fertility Institute of CIAT) 2005. Integrated soil fertility management. From Knowledge to Implementation. CIAT Colombia.
- Vanlauwe B. 2004. Integrated soil fertility management research at TSBF: The framework, the principles and their application. In: Bationo A. (ed). *Managing Nutrient Cycle to sustain soil fertility in sub-Saharan Africa*. Academy Science Publishers, Nairobi-Kenya. Pp 25–42.
- Vanlauwe B., Diels J., Sanginga N. and Merxck R. 2002. Integrated plant nutrient management in sub-Saharan Africa: From Concept to Practice: CABI, Wallingford: UK.
- Veldhuizen V.L., Waters-Bayer A. and Zeeuw H. 1997. Developing technologies with farmers. A trainers' guide for participatory learning. Zed Books Ltd. London and New York.
- Woome P.L. (2004) cost and return of soil fertility management options in western Kenya. Paper presented at the African Network for Soil Biology and Fertility (AfNet) International symposium on improving human welfare and environmental conservation by empowering farmers to combat soil fertility degradation symposium, Yaoundé, Cameroon, May 17–21.
- Wortmann C.S. and Kaizzi C.K. 1998. Nutrient balances and expected effects of alternative practices in farming systems of Uganda. *Agriculture, Ecosystems and Environment* 71: 115–129.

Scaling Up Options on Integrated Soil Fertility management in Western Kenya: The Case of COSOFAP: Challenges and Opportunities

Qureish Noordin^{1*}, John Mukalama², Daniel Rotich³, Electine Wabwile⁴ and John Lynam⁵

¹World Agroforestry Center, Western Kenya Programme, P.O. Box 2389, Kisumu, Kenya; ²TSBF-CIAT; ³Kenya Agricultural Research Institute; ⁴Ministry of Agriculture, Bungoma District, Kenya; ⁵The Rockefeller Foundation;

*Correspondence author: q.noordin@cgiar.org

Abstract

Western Kenya, a densely populated region of the country is an example of many areas in Africa where continued threat to the world's land resources is compounded by the need to raise food production and reduce poverty. Attainment of food security is intrinsically linked with reversing agricultural stagnation, safeguarding the natural resource base, slowing population growth rates, combating the negative impacts of HIV/AIDS pandemic on the community and reducing poverty. Over the last 12 years, the World Agroforestry Centre (ICRAF) in collaboration with Kenya Agricultural Research Institute (KARI), Kenya Forestry Research Institute (KEFRI) and Tropical Soil Biology and Fertility Programme (TSBF) and with support from the Rockefeller Foundation developed several integrated soil fertility management (ISFM) options. Examples are: (i) short-duration improved fallows with leguminous nitrogen-fixing species, such as *Sesbania sesban* and *Crotalaria grahamiana*; (ii) biomass transfer of *Tithonia diversifolia*; (iii) dual purpose legumes like soybeans and cowpeas and iv) the combination of phosphorus fertilizers, including the reactive Minjingu phosphate rock, with the above organics and farmyard manure. These options that can increase yields of maize by 2–3 folds were tested and adopted by thousands of farmers in pilot project sites in Vihiga and Siaya Districts. Other work has been pioneered by ICIPE on Push–Pull technology, MBILI by Sacred Africa, green manuring by the Legume Research Network. Besides yield improvements, other benefits associated with improved soil fertility management strategies include striga control, fodder, wood fuel production and stakes for climbing beans. However one of the biggest challenges is to scale these initiatives to more farmers in the region.

To scale up this and other promising technologies, a Consortium for Scaling Up Options for Improving Soil Fertility in Western Kenya (COSOFAP) of over 80 partners was initiated in January 2001. COSOFAP covers 22 districts of western Kenya and reaches thousands of farmers with quality germplasm and information. Links to private sector and policy makers have also been strengthened. This paper highlights some of the salient features of the ISFM options available and their dissemination pathways through the consortium of partner institutions and the empowerment of farmers to train others and scale up the options through Interactive Learning Sites

Key words: Integrated Soil Fertility management, scaling up

Introduction

Western Kenya, a densely populated region of the country is an example of many areas in Africa where

the continued threat to the world's land resources is compounded by the need to raise food production and reduce poverty. Here attainment of food security is intrinsically linked with reversing agricultural

stagnation, safeguarding the natural resource base, slowing population growth rates, combating the negative impacts of HIV/AIDS pandemic on the community and reducing poverty. Farmers in this region experience the severe land use problem of low and declining soil fertility, which is reflected in low crop yields, shortage of fodder and fuel wood, and low income from farming activities. This has resulted in serious problems of food insecurity, poverty and degradation of natural resources.

The above problems are further exacerbated by acute food insecurity that is rampant in most parts of the region. According to Sanchez and Leakey (1997) food insecurity does not just refer to the scarcity of food but also to the inability to purchase food products, which in turn is directly linked to poverty. In the 1960s, Africa was sufficient in food production and a number of countries were major food exporters (Ref). However, intense site degradation and soil fertility depletion have in turn decreased household food production and further increased the demands for natural resources. This has greatly changed and World Bank estimates that per capita food production has been declining at the rate of 2% per annum since the 1960s (World Bank, 1996). About half of Africa's population live in rural areas and are classified as absolute poor. Agricultural productivity has therefore continued to decline given the rising costs of inorganic fertilizers, which is beyond the economic reach of most farmers and coupled by lack of know how (Mugendi 1990). Within the Western Kenya region, a major focus of the partners has been the highlands where the high populated pressure and associated problems of small and often land fragmented land holdings has in many places led to environmental degradation. This is most exemplified in many areas by declining soil fertility and land productivity. In general, the soils are phosphorus deficient, in part due to their medium to high P fixing capacity and in part due to depletion through cropping for long periods of time with little or no inputs (Smaling et al., 1997). To a lesser extent, the soils are also potassium deficient.

With low and declining soil fertility, *striga hermonthica*, a parasitic weed that devastates cereal crops, has invaded the cropland and is depressing yields further. The result of this is food insecurity, lasting between 3 and 9 months per year in many farms. The other problem is concerned with lack of appropriate soil fertility management packages that can be combined in integrated nutrient management strategies for sustainable natural resource management. Inadequate understanding of the socio-economic and cultural

issues that pertain to adoption of soil fertility management strategies and the policy environment that is conducive to investment in natural resource management are also main constraints. There also exists a knowledge gap with respect to the role of soil fertility management in household livelihood strategies. In addition, input supplies and market linkages have been major bottlenecks for enhanced productivity.

Over the last 12 years, various efforts have been initiated to address the problem of low soil fertility in western Kenya. Several programs and projects that aim at developing and disseminating various options for improving farm productivity (in particular soil productivity) were initiated in western Kenya and some are still going on. Some of the major programs include the:

- a) Pilot project on soil fertility recapitalization and replenishment in western Kenya, a collaborative project between KARI-KEFRI-ICRAF
- b) African Highlands Initiative – an ecoregional program with a benchmark site in western Kenya
- c) The Legume Research Network Project (LRNP)
- d) SCODP (Sustainable Community Oriented Development Project)
- e) KARI-Kisii with the PRIAM project
- f) KARI – Kakamega with the PLAR (Participatory Learning Action Research) Project
- g) KARI with activities on potassium research
- h) ICRAF working on agroforestry research and development
 - i) Kenya Forestry Research Institute (KEFRI)
 - j) International Centre for Research on Maize and Wheat Improvement (CIMMYT)
 - k) Tropical Soil Biology and Fertility (TSBF)
 - l) International Centre for Research in Insect Physiology and Ecology (ICIPE)
- m) SACRED AFRICA with the best bet options.

Integrated soil fertility management options

In western Kenya quite a diverse basket of options for ISFM are being developed and disseminated with farmers. This reflects the diverse requirements in terms of biophysical and socio-economic conditions. Some of these include: short-duration (6–12 months) improved fallows with leguminous nitrogen-fixing species, such as *Sesbania sesban* and *Crotalaria grahamiana* (Buresh and Tian, 1998; Jama et al., 1998), biomass transfer of *Tithonia diversifolia* that can be

grown around and within farms to make boundaries or as contour hedges (Jama et al., 2000; Gachengo et al., 1999) and the combination of phosphorus fertilizers, including the reactive Minjingu phosphate rock, with improved fallows, tithonia and farmyard manure. These options that can increase yields of maize by 2–3 folds were tested and adopted by thousands of farmers in pilot sites in Vihiga and Siaya Districts. Besides yield improvements, other benefits associated with improved soil fertility management strategies include striga control, fodder, wood fuel production and stakes for climbing beans. The Push–Pull technology being spear-headed by ICIPE has shown tremendous promise in striga control and fertility improvement especially in areas with smaller pieces of land. Green manuring options including dual purpose legumes (cowpeas, soybeans) have been introduced to farmers by TSBF and KARI. Pigeon peas have also been another option promoted by ICRISAT. Other options include fortified composting by Moi University. In addition, fertilizer use has been promoted extensively using innovative channels by SCODP. NGOs have taken a leading role in promoting conservation agriculture methods including double digging and liquid manure application. Apart from the soil fertility options, high value crops have been an integral part of the initiative on soil fertility improvement. This is due to the fact that farmers would like to enhance their production by enhancing their income generation hence the diversification to other crops.

Though these efforts have contributed to increased productivity and incomes, these technologies are still being practiced by relatively fewer farmers in the communities. This success in scaling out successful technologies has also been limited to a few pilot sites and efforts to cover more ground and people has been hampered by the uncoordinated nature of the various research and development organizations in the region (Noordin et al., 2001). This has often resulted in duplication and fragmentation of effort and hence poor impact. To correct this situation, there is need for these organisations to forge strong partnerships and add value to each other's programs. There is also need to partner with the private sector and link farmers with markets and rural development programs in order to enhance impact and ensure sustainability. There is thus need to coordinate such efforts in order to reach and impact on a wider population. This formed the basis for the initiation of a consortium of partners in western Kenya known as Consortium for scaling options for increased farm productivity in western Kenya (COSOFAP).

Background

The Consortium for Scaling Up Options for Increasing Farm Productivity in Western Kenya (COSOFAP) was initiated in 2001 to address the problems of increasing soil fertility degradation contributing to perpetual food and wood shortages consequently reduced incomes and poverty levels. It was formed in response to demands by farmers and other stakeholders for holistic and up to date information on options which could be scaled up across districts in western Kenya. This was due to the localized adoption and impact that many programmes/ projects achieved in their working areas, be they research institutions, NGOs, CBOs, local community groups or government ministries. There was also the realization that it had to involve stakeholders dealing in diverse areas of integrated natural resources management and not only limited to those dealing with soil fertility.

COSOFAP emerged gradually from the efforts of several projects in the region among them i) the KARI/KEFRI/ICRAF Project on soil fertility replenishment which used the village and sub-location units to develop a community based dissemination system, ii) the Kenya Woodfuel and Agroforestry Project (KWAP) which used the catchment approach, and, iii) the CARE Agroforestry Project which used the TRACE method (Noordin, 2001). Building on the experiences of the KWAP and CARE projects, the KARI/KEFRI/ICRAF project in 1997 engaged a village approach which aimed to make all farmers in the entire village become adaptive research farmers by working with groups who are representative of village committees as a means of creating awareness and disseminating information and technologies on a wide scale (Noordin et al., 2000).

Currently COSOFAP has close to 100 members who include organizations and institutions interested in promotion of improved farming practices in a sustainable manner. Members range from international and national research institutions, government departments, NGOs, CBOs, private sector, farmer groups and associations and educational institutions. Its goal is alleviating poverty of the about 60% resource poor farmers in western Kenya through increased farm productivity taking into account sound environmental sustainability. To achieve this, COSOFAP is guided by the following vision, mission and purpose – **Vision:** To alleviate poverty among the resource poor farmers of western Kenya by increasing farm productivity using sustainable and environmentally sound

strategies; **Mission:** To increase farm productivity through increased access and use of agricultural technologies as a result of improved delivery mechanisms; and **Purpose:** Improve and increase farm productivity through networking of research and development partners to avail appropriate options and information to empower poor farmers of western Kenya. The Consortium also strives to develop community self-reliance – to support communities as they identify needs, understand benefits of alternative interventions and pay for some costs associated with acquiring necessary skills or information to move forward.

Objectives of COSOFAP

1. Facilitate information sharing amongst partners
2. Facilitate advocacy on natural resource management and policy
3. Facilitate capacity building
4. Coordinating partnership linkages and networking
5. Facilitate monitoring and evaluation
6. Documentation of the lessons learnt
7. Scale up both technical options and participatory process related to soil fertility Initiatives

Structure of COSOFAP and operational strategy

An operational structure has been in place since the inception of the consortium in January 2001 and is modified and improved with the lessons and experiences gained. The present structure of the consortium is shown below in Figure 1.

The regional co-ordinating team (RCT)

The Regional Coordinating Team (RCT) is composed of members drawn from the government departments, NGO, CBO, Private sector, KARI, KEFRI, ICRAF, Local policy makers and farmer representatives. The RCT is charged with the responsibilities of coordinating the activities of COSOFAP. It is supported by several sub-committees and a secretariat. Currently the sub-committees are in resource mobilization, information, technical, local policy and monitoring and evaluation. The role of the Secretariat is to provide the necessary coordination and administrative support. The chair is from the Ministry of Agriculture and ICRAF provides the coordinator to the secretariat.

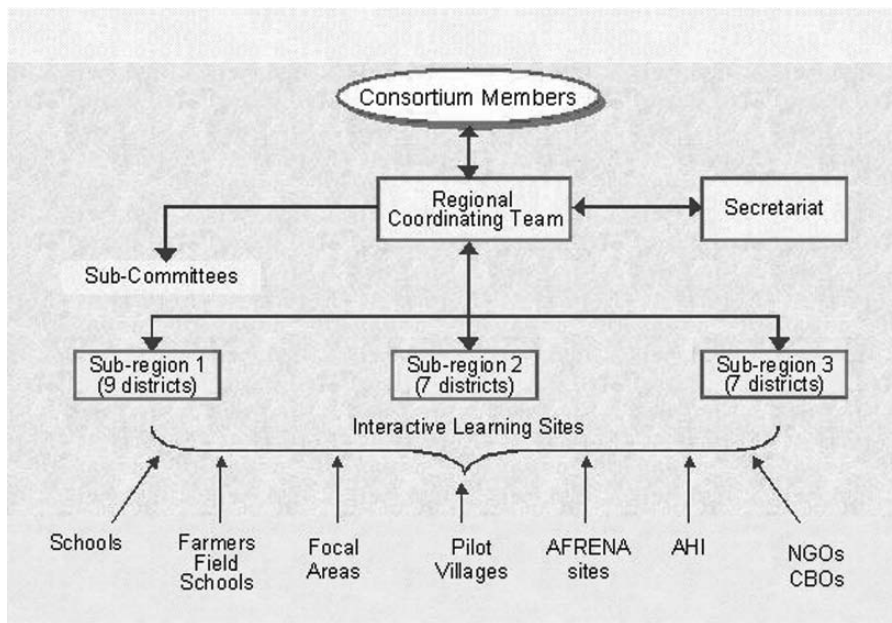

Figure 1. COSOFAP – Structure of Consortium of partners

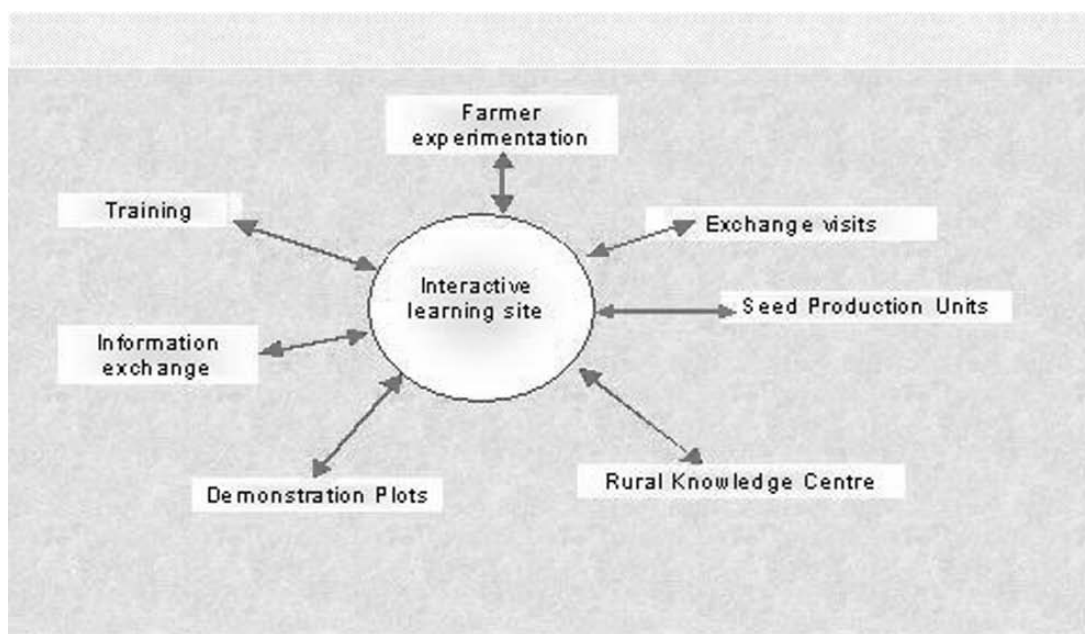

Figure 2. COSOFAP – Interactive learning sites of the Consortium partners

Sub-regional committees

To facilitate efficient management of the whole region, the partners divided the region into 3 sub-regions, which are run by the Sub-Regional Coordinating committees. At the sub regional level, membership is more from farmers, CBOs and NGOs and other development agents. The sub-regions develop the calendar of activities and prioritise the training and germplasm needs for the sub-region.

Interactive learning sites (ILS)

One of the major strengths of the consortium is the use of existing grass root sites referred to as Interactive Learning Sites. These are operational sites for partners who already have them as project sites. The consortium will use such sites to scale up the different options and will act as training grounds, seed production units, exchange visits and more importantly as local centres for knowledge exchange and learning. Examples of such sites include: Farmer Field Schools, Shifting Focal Areas (National Agricultural and Livestock Project – NALEP), Villages, Groups and Schools. All the activities of the partners are conducted through the use of Interactive Learning sites (ILS).

Learning sites (Figure 2) are information exchange sites where partners and farmers come together and share their experiences and also see from the demonstration sites on-going technologies. These are locations where research and development activities have been piloted before and where farmers and extension agents can learn. Such locations are dotted strategically all over the western Kenya region being supported by previous and on-going projects. Examples of such centres are schools (both primary and secondary), Farmer Field Schools (FFS), National Agricultural and Livestock Extension (NALEP) Focal areas, RELMA's Catchment committees, ICRAF/KARI/KEFRI Pilot village committees, KARI-Kisii Adaptive Research Farms, etc

Key building elements of COSOFAP

It is very critical when establishing such a consortium to take cognisance of existing initiatives and add value to what their undertaking and do not compete. It is also crucial that the consortium does not compete with its members especially on funding for the same activities. Thus the need to come up with key strategic or building elements. For COSOFAP these include:

- Build upon scaling-up experiences of partners – many partners are already doing scaling up work hence COSOFAP comes strongly in coordination efforts.
- Strategic partnerships
- Scale-up technical options and participatory process
- Use interactive learning centres/sites to ensure relevance at the grassroots level
- All inclusive ownership of consortium
- Emphasis on adaptive research/farmer experimentation innovations
- Facilitate monitoring and evaluation and feedback amongst partners
- Strengthen Farmer–Extensionist–Researcher–Private sector linkages
- Strengthen existing institutions especially local
- Diverse dissemination approaches
- More farmers practicing soil fertility options – 2000 farmers testing the options and over 30,000 practicing the other options
- Formation of functional structures at regions and sub-regions which have become platforms for interaction and information exchange.
- Forum for dialogue with politicians and policy makers
- Forum for regional activities – training by USAID/PACT on strategic planning, Lake Victoria Local Authorities workshop
- Enterprise development such as Vihiga mushroom project was founded after COSOFAP training on fundraising
- More funding for partners associated with COSOFAP – Maendeleo Agricultural Trust Fund has awarded three partners
- Enhanced informal collaboration/networking among partners – increased farmer exchange visits informally arranged
- Partners trained by other organizations – SCOBICS, Africa Now have trained farmers and partners outside their mandate areas in support of the consortium
- Joint sourcing of inputs/materials e.g. Dairy goats
- Joint sourcing of markets – honey, fruits
- Trainings conducted in many areas (Soil fertility options, High value trees/grafting, Resource mobilization and developing winning proposals, Strategic Planning and Governance (regional), Poultry and Bee keeping (assistance from Africa Now)

COSOFAP achievements

Since its establishment, COSOFAP has undertaken a number of activities and has some experiences and achievements that it can share (Table 1). Some of the achievements include:

- More than 100 partners are affiliated to the consortium
- Over 100 interactive learning sites across the districts have been developed
- 30 bulking sites for various germplasm in the region

Table 1. COSOFAP achievements

Activity	Target group	Number of participants
Exchange visits (Regional – Uganda)	Farmers, Extensionists, Researchers, Private sector	30
Exchange visits (Local)	Farmers, Extensionists	200
Field days	Farmers, Extensionists, Traders, Private sector, Researchers	600
Training on fundraising and proposal writing	Farmers, Extensionists, Researchers	30
Training on bee keeping	Farmer trainers	200
Training on grafting/ budding	Farmer Trainers/Nursery operators	100
Training on strategic planning and governance	NGO, CBO, Ministry Staff	40
Training on soil fertility	Farmers, Farmer Trainers	500
Training on soil fertility	Extensionists/CBOs, NGOs, Ministry	100
Training on tree nursery establishment	Farmer Trainers	200
Local poultry	Farmer Trainers	200
Training on Environmental Impact Assessment of local projects	Field practitioners – supported by USAID	30
Training on value addition and processing	Farmers, Extension	50

- Exchange Visits – including one to Uganda
- Field Days
- Support to professional training/workshops (support to members who attended Soil Science Society of East Africa and Sustainable Agriculture meetings in Uganda)
- Development of a Directory of Partners
- Directory of Learning Sites
- Development of extension materials
- Training notes for farmers
- Web Site development (www.ugunja)
- Germplasm distribution and bulking in the region: one of the critical issues when scaling up is the timely availability of quality germplasm. Over one tonne of seeds have been distributed (Repetition – see point 3 above).
- Forum for discussing crosscutting issues e.g. HIV /AIDS

Challenges in scaling up

Scaling up of both options and processes has proven to be a formidable task but worth the efforts. Major challenges include:

- Partnership modes – if not well thought out, partners can have divergent interests and slow the progress of the consortium
- Managing and coordinating partnerships – this has to reflect all inclusive ownership, common vision and no favouritism to certain partners
- Germplasm availability of both high quality and demanded quantity
- Decision support tools
- Recommendation domains for specific products (species) should be well thought of in advance
- Resources for coordination and administration
- Keeping track (monitoring and follow-up) of the processes
- Collective action (conflict management)
- Impact assessment of both the partnerships and technological options involved.

Key lessons learnt

During the implementation of its strategies, the consortium of partners has learnt that:

- Partnership appraisal is a critical phase as it's important to identify critical and willing partners. This is

essential in getting active involvement of partners with diverse approaches and options.

- Buy in is very (Not clear) critical at early stages and getting commitment from decision-makers early enough is essential. Through COSOFAP, the partners have learnt that institutions can beneficially work together
- It is vital to start small then expand and become more inclusive
- Scale up both options and processes
- Involve all key stakeholders early enough right from conceptualisation
- In the beginning of the formation of the structures, it is advisable to hold monthly meetings at least for the first six months. A dynamic secretariat is key in running the day to day operations of the partnership. Currently COSOFAP lacks a permanent secretariat due to limitations in funding
- Monitoring and evaluation processes should be developed together with farmers and put in place as soonest as possible
- Quality and adequate quantity of germplasm should be in place in good time to support the activities of the partners particularly at the interactive learning sites
- Not all will join, see how and where to synergise
- Link with national strategies like the National Agricultural and Livestock Extension Programme – NALEP of the Ministry of Agriculture as this is very helpful in targeting the farmer
- Transparency and accountability of all actions particularly in use of resources channeled to the partnership.

Way forward

COSOFAP has held various interactive meetings and discussions and a summary of recommendations from this forums on the way forward in scaling up the soil fertility initiatives, among others, include:

- Establishment of similar initiatives or dissemination pathways in other parts of the country. Currently, discussions have been held between the World Agroforestry Centre (ICRAF) and KARI sub-regional centers representatives in Eastern- Machakos, Central – Embu and Coast – Mtwapa on the possibilities of starting consortiums for this regions and plans are at inception stages.

- Incorporate other research institutions more effectively especially CIMMYT, ICIPE, International Centre for Potato Research – CIP, International Centre for Research in Semi-Arid Tropics – ICRISAT and International Plant Genetic Research Institute – IPGRI at the regional level, to enhance linkages and information sharing among and between institutions
- The mandate/scope of the consortium should be increased to include other enterprises apart from soil fertility and agroforestry. Challenges faced in activity implementation should be taken up as opportunities to address emerging problems and issues
- Linkages with other Networks/Consortia in the country and in neighbouring countries should be enhanced especially INSPIRE in Uganda and MWANGO in Tanzania in order to cast the net widely and improve the livelihood standards of the farmers

Conclusion

The consortium has continued to receive positive response and recognition from the government and development partners. More importantly it has demonstrated that strategic and genuine partnerships can work even in situations where we have large numbers of diverse representations. More importantly is that it has given voice to many farmer groups who now can link to many service providers in the region and outside the region. As far as soil fertility initiatives are concerned it has shown that scaling up can actually be done – **“...More people, more quickly, more lastingly...”**

One farmer said: *“If you work with 3 or 5 farmers in our village, we do not see anything tangible, the whole village needs to be involved if we are to prosper”... a farmer from Soso village*

References

- Buresh R.J. and Tian G. 1998. Soil improvement by trees in Sub-Saharan Africa. *Agroforestry Systems* 38:51–76.
- Gachengo C.N., Palm C.A., Jama B. and Othieno C. 1999. Tithonia and Senna green manures and inorganic fertilizers as phosphorus sources for maize in western Kenya. *Agroforestry Systems* 44:21–36.
- Jama B., Palm C.A., Buresh R.J., Niang A., Gachengo C., Nziguheba G. and Amadalo B. 2000. *Tithonia diversifolia* as green manure for soil fertility improvement in western Kenya: A review. *Agroforestry systems* 49: 201–221.
- Jama B.A., Buresh R.J., Ndufa J.K. and Shepherd K.D. 1998. Vertical distribution of tree Roots and Soil Nitrate: Tree Species and Phosphorus Effects. *Soil Science Society of American Journal*, 62: 280–286.
- Mugendi D.N. 1990. Plant nutrient of mulch incorporated in Alley cropping trials of semi-arid Machakos, Kenya. MSc. Thesis. University of Nairobi. Nairobi, Kenya.
- Noordin Q., Niang A., Jama B. and Nyasimi M. 2001. Scaling up adoption and impact of Agroforestry technologies: experiences from western Kenya. *Development in Practice* 11: 509–523.
- Noordin Q., Nyasimi M., Niang A., Ruigu S. and Jama B. 2000. Facilitating dissemination and scaling up strategies in the Maseno pilot project on soil fertility replenishment and recapitalization. In: Nyasimi M., Noordin Q., Jama B. and Ruigu S. (Eds) *Dissemination and Extension Methodologies for Integrated Soil Fertility Management Practices in Western Kenya*, proceedings of a workshop held at ICRAF, Kisumu, 25–26 January 2000, Nairobi: International Centre for Research in Agroforestry.
- Sanchez P. A. and Leaky R. 1997. Land use transformation in Africa: Three determinants for balancing food security with natural resource utilisation. *European Journal of Agronomy*, Amsterdam, Netherlands.
- Smaling E.M.A., Nandwa S.M. and Janssen B.H. 1997. Soil fertility in Africa is at stake, pp. In: Buresh R.J., Sanchez P.A. and Calhoun F. (eds.), *Replenishing soil fertility in Africa*. Soil Science Society of America Special Publication 51: 47–62. Soil Science Society of America, Madison, WI. USA.
- World Bank 1996: *Africa Development Indicator 1996*: World Bank, Washington, WA 431 pp.

Socio-Economics of Soil Conservation in Kericho District, Kenya

Kipsat M.J.

*Department of Agricultural Economics and Resource Management, Moi University, P.O. Box 1125, Eldoret, Kenya,
E-mail Address: mjkipat@yahoo.com, Phone numbers: +254 722583130, +254 735640976, +254 532031481,
Fax: +254 532031481*

Abstract

High population pressure in Kericho district has led to encroachment of fragile lands like steep slopes and forests. Adoption rate of recommended soil conservation practices is low and available literature shows that soil conservation programs have been launched without evaluation of farmers' attitudes and perceptions. Past studies stressed on examining nature and severity of soil degradation leaving an empirical gap on socioeconomic factors affecting adoption of promoted technologies. The objective of this study was to analyse the effect of farm, farmer and technology characteristics on adoption of promoted soil conservation technologies. Multistage sampling procedure and structured questionnaires were used to collect cross-sectional primary data in sloppy parts of Kericho district. Binomial Logit models were used in data analysis. The results indicate that adoption of stone lines is affected by security of tenure, household income, decision-maker's sex and education level and farm's biophysical features. Adoption of unploughed strips was affected by perception of profitability, decision-maker's sex and education level, extension visits and farm's biophysical features. Adoption of grass strips was affected by extension visits, farm size and biophysical features. Adoption of terracing was affected by decision-maker's age, security of tenure, household income, perception of profitability, extension visits, farm size and biophysical features. Results from this study are useful in making policy recommendations. The study recommends that effect of indigenous knowledge on conservation be analyzed and considered in extension advice. Leaders and politicians need to address environmental degradation in public meetings to change skeptical attitudes held by farmers towards conservation practices

Key words: adoption, conservation, erosion, socioeconomic, technologies

Introduction

Kericho District is a major agricultural zone producing many cash crops such as tea, coffee, pyrethrum, maize and sugarcane. The district contributes significantly to pollution of waterways because of soil erosion. It is also associated with use of high rates of agrochemicals particularly in production of cash crops. The downstream effect of soil degradation in water quality is evident in Lake Victoria where the emergence of water hyacinth gives an indication of extreme levels of eutrophication. Soil conservation technologies promoted in Kericho District include the following: terracing;

drainage ditches; river bank dykes, plain ridging; stone lines; gabion weirs; unploughed and grass strips; and agroforestry. Gabion weirs and dykes are used to control gullies and river floods. River bank conservation is practiced where farmers cultivate along river banks.

Many organizations are currently engaged in researches dealing mainly with biological and physical aspects of soil in the study area. In many of the soil conservation studies, needed experience and technical knowledge are available to provide technical solutions to problems of soil degradation (Berger, 1996) but adoption of soil conservation is still low.

Socio-economic conditions of the study area's farm households in soil conservation have been given little attention by studies undertaken so far. However, studies in other regions indicate that socio-economic variables greatly influence adoption of soil conservation practices in farmers' fields (Lutz et al., 1994; Kagwanja, 1996; Tiffen et al., 1994; Shiferaw and Holden, 1998; De la Briere, 1999; Odendo, 2000). Research studies indicate that most farmers do not adopt recommended soil conservation practices or abandon them once projects promoting them end soil conservation financial and material support (Berger, 1996; Scoones et al., 1996; Thompson and Petty, 1996). The main objective in this study was to determine effects of farm, farmer, and technology characteristics on adoption of selected soil conservation techniques using selected households in Kericho district. It was hypothesised that farm, farmer and technology factors have no significant effects on adoption and choice of soil conservation techniques.

Methodology

The population was divided into three sampling units represented by three divisions (Londiani, Kipkelion and Sigowet) of Kericho District whose rivers and streams drain into river Nyando and which are prone to soil erosion. Simple random sampling was done to select respondents. At least forty farms were selected from each division so that data for this study was collected from all soil conservation points in the study area in which a total of 200 households were interviewed.

Data collection was done between October and December 2003. Ten enumerators were chosen in each division, trained for enumeration exercise and served with questionnaires. Single-visit formal surveys, conducted using semi-structured questionnaires were orally administered to farmers with the help of enumerators who knew and were conversant with the farmers' local language and customs. They consisted of divisional agriculture staff and field extension workers. The questionnaires had been pre-tested with a random sample of 40 farmers in Ainamoi division, Kericho. Primary and secondary data were used in this study.

Information was collected through administration of questionnaires and focused on farmers' incomes, age, gender, and education level, farm size, security of tenure, and biophysical characteristics of the farm. Others information collected included frequency of

extension visits and farmer's perception of profitability of promoted soil conservation technologies. SPSS software was used to carry out a binomial logit analysis of the factors postulated to affect adoption of modern soil conservation techniques on adoption of the selected soil conservation technologies in the study area. Multicollinearity, autocorrelation and heteroscedasticity were considered. Autocorrelation of data was assumed minimal because no time series data was included in analyses. The logit model is known to have no problem of heteroscedasticity. The problem of multicollinearity between pairs of explanatory variables was assessed by computing the Pearson correlation test coefficients. Multicollinearity was considered insignificant when Pearson correlation is less than 0.5.

Results and discussions

The overall goodness of fit measures for the four binomial logit regression models were 89.66%, 85.56%, 84.34% and 66.67% for stone lines, unploughed strips, grass strips and terraces respectively. Goodness of fit values were generally reasonably good enough for making useful predictions on the factors that influence the probability of adopting the specified soil conservation measures. The maximum likelihood coefficients were examined at 0.01, 0.05, and 0.1 levels.

Results

The results indicate that adoption of stone lines (Table 1) is affected by security of tenure (at 10% level), household income (at 5% level), sex of decision-maker (at 10% level), farm's biophysical features (at 10% level) and education level of decision-maker (at 5% level). Adoption of unploughed strips (Table 2) is affected by perception of profitability (at 1% level), decision-maker's sex (at 5% level), extension visits (at 10% level), biophysical features of the farm (at 5% level) and education level of decision-maker (at 5% level). Adoption of grass strips (Table 3) is affected by frequency of extension visits (at 5% level), farm's biophysical features (at 10% level) and farm size (at 5% level). Adoption of terracing (Table 4) is affected by decision-maker's age (at 5% level), security of tenure (at 1% level), household income (at 5% level), farmers' perception of profitability (at 10% level), frequency of extension visits (at 5% level), biophysical features of the farm (at 10% level) and farm size (at 5% level).

Table 1. Regression Statistics for Adoption of Stone Lines

Explanatory Variable	Coefficient	Standard Error	t-ratio	Significance
Age of family decision-maker	-0.3050	0.6737	0.4527	0.6507
*Security of tenure	0.8910	0.5048	1.765	0.0776
**Total income of household	1.886	0.8750	2.155	0.030
Perception of Profitability	0.1791	0.897	0.1997	0.842
*Sex of family decision-maker	1.732	0.9314	1.859	0.064
Frequency of extension visits	0.1791	0.8971	0.1997	0.8421
**Biophysical features of farm	1.109	0.639	1.736	0.0826
**Education of decision-maker	0.884	0.4639	1.906	0.034
Size of the household	0.009	0.028	0.3214	0.7412
Farm size	-0.868	0.6643	1.307	0.1911
Constant	-1.521	1.926	0.7917	0.4301

* Indicates that the variable is statistically significant at 10 % confidence level; ** Indicates that the variable is statistically significant at 5% confidence level.

Table 2. Regression Statistics for Adoption of Unploughed Strips

Explanatory Variable	Coefficient	Standard Error	t-ratio	Significance
Age of family decision-maker	0.028	0.030	0.9333	0.3564
Security of tenure	0.078	0.2271	0.3436	0.7291
Total income of the household	0.3252	0.5261	0.6178	0.5362
***Perception of Profitability	2.272	0.6861	3.309	0.0013
**Sex of family decision-maker	-2.371	1.113	2.129	0.0331
*Frequency of extension visits	-1.663	0.946	1.755	0.079
**Biophysical features of farm	2.282	0.9072	2.514	0.012
**Education of decision-maker	2.270	0.6861	3.309	0.013
Size of the household	0.078	0.2271	0.3436	0.7291
Farm size	-1.1299	0.8212	1.376	0.1688
**Constant	5.038	2.391	2.108	0.0349

* Indicates that the variable is statistically significant at 10% confidence level; ** Indicates that the variable is statistically significant at 5% confidence level; *** Indicates that the variable is statistically significant at 1% confidence level.

Table 3. Regression Statistics for Adoption of Grass Strips

Explanatory Variable	Coefficient	Standard Error	t-ratio	Significance
Age of family decision-maker	-0.0362	0.0261	1.1346	0.1701
Security of tenure	0.1492	0.3613	0.4127	0.6791
Total income of the household	0.2751	0.4261	0.6455	0.5195
Perception of Profitability	0.1376	0.7031	0.1957	0.8448
Sex of family decision-maker	1.108	0.886	1.219	0.211
**Frequency of extension visits	0.1930	0.603	3.201	0.023
*Biophysical features of farm	1.421	0.7491	1.896	0.058
Education of decision-maker	0.1391	0.8158	0.1705	0.8646
Size of the household	0.1414	0.2441	0.5781	0.5641
**Farm size	-1.930	0.6031	3.201	0.023
Constant	-2.712	2.051	1.322	0.1971

* Indicates that the variable is statistically significant at 10% confidence level; ** Indicates that the variable is statistically significant at 5% confidence level.

Table 4. Regression Statistics for Adoption of Terraces

Explanatory Variable	Coefficient	Standard Error	t-ratio	Significance
**Age of decision-maker	-0.049	0.024	2.042	0.045
***Security of tenure	3.281	0.6961	4.713	0.000
**Total income of household	0.672	0.342	1.965	0.049
*Perception of Profitability	1.720	0.9322	1.845	0.063
Sex of family decision-maker	0.222	0.701	0.3138	0.7541
**Frequency of extension visits	1.886	0.8751	2.155	0.0311
*Biophysical features of farm	1.732	0.931	1.858	0.064
Education of decision-maker	0.0281	0.1761	0.1591	0.872
Size of the household	0.3790	0.4910	0.7719	0.4401
**Farm size	-1.030	0.4013	2.569	0.0278
Constant	2.191	1.670	1.3114	0.189

*Indicates that the variable is statistically significant at 10% confidence level; ** Indicates that the variable is statistically significant at 5% confidence level; *** Indicates that the variable is statistically significant at 1% confidence level.

Discussions

Age negatively affected adoption of all considered soil conservation technologies except unploughed strips where age of decision-maker had negative correlation with farmer's decision to adopt technology. Effect of age on adoption however was not statistically significant for all analyzed technologies except for terracing that was significant at 5% level. The above observation is probably due to labor demands of the technologies. Soil conservation technologies are highly labor intensive and older farmers tend to shy away from them while younger decision-makers tend to accept the technologies, as they are energetic. Lack of significant contribution of age of decision-maker to whether farmers adopt technologies is because farmers of all ages had equal access to technologies. Variations arising from age differences were therefore not statistically significant except for terracing in which high labour demands tended to exclude older decision makers.

Young (below 45 years of age) decision-makers tended to better conserve soil than old decision-makers (above 65 years of age) did. The young decision makers are easily persuaded to adopt soil conservation compared to old decision makers. Soil conservation activities are highly labour intensive and require dextrous individuals especially the youth. Older farmers seem to have a negative attitude towards soil conservation activities and this is aggravated by limited education on the importance of soil conservation.

Education level of the household decision-maker positively correlated with adoption of all the soil conservation technologies reviewed in this study. The effect however was not statistically significant for

terracing and grass strips. At 5% level, the effect of education was statistically significant for stone lines and unploughed strips. The positive correlation is explained by the fact that formal education raises awareness on the need to conserve soil. Education is vital in understanding soil erosion processes, effects and remedial measures. Soil erosion is a crisis that goes on at imperceptible rates and is consequently given insufficient attention although its long term effects would be worse than those published as natural disasters such as earthquakes, land slides, and volcanic eruptions (Brown and Wolf, 1984).

With formal education, farmers have a better understanding of the fact that erosion poses an environmental threat. Therefore, formal education gives farmers knowledge that is needed as power to motivate them to adopt the promoted soil conservation practices. Because of limited education, most farmers find it more logical to explain declining yields arising from loss of fertile soil to erosion in terms of easily recognizable aspects such as irregular rainfall, crop pests, diseases and lack of yield enhancing inputs than in terms of soil degradation. Conservation strategies therefore fail to gain acceptance among farmers with limited education especially formal education.

Farm size negatively correlated with the adoption of all the considered soil conservation technologies considered in this study. The effect was not statistically significant for stone lines and unpoughed strips but was significant at 5% level for grass strips and terracing. In this study, farmers with small parcels of land tended to adopt soil conservation technologies than farmers with large parcels of land. This is because farmers with large farms lack capital to invest on the farm. In many

situations farmers have no access to credit facilities for various reasons that range from institutional to cultural factors. Operators of larger farms are likely to spend more money on conservation mainly because larger farms are associated with greater wealth and more access to financial resources and technical support, which makes investment in soil conservation more feasible (Clay and Reardon, 1994; Napier, 1994). This relationship is unlikely to be true in most parts of Kenya where subsistence farming dominates. There is limited availability of credit to subsistence farmers. Farmers growing maize for example, have to have more than two ha to qualify for credit, a provision that eliminates smallholder farmers. Even when credit is available, it is primarily for purchases of inputs such as fertilizers for export or cash crops like tea, coffee and French beans, not for subsistence enterprises.

Income positively affected adoption of all soil conservation technologies reviewed in this study. The effect however was not statistically significant for unploughed strips and grass strips. The effect was statistically significant at 5% level for stone lines and terracing. As expected, farmers' tendency to adopt technologies in this study increased with increase in income. As incomes improve farmers tend to allocate more of it to conservation of the environment. The lack of statistical significance of income in affecting adoption of unploughed and grass strips is because the technologies are less labour intensive than terracing and stone lines so that an increase in income does not translate into a significant change in proportion of labour engaged in the less labour intensive technologies.

Household income tends to increase the farmers' ability to employ labour intensive technologies. This explains why adoption of terracing and stone lines was affected by income in a statistically significant way. The positive income variable coefficients indicate that income increases the ability of households to improve the quality of their labour. Past studies indicate that people with higher incomes are more likely to be selected for training. This means that such farmers have better knowledge of new technologies and thus are better placed when it comes to adopting the technologies.

Poverty induces land degradation as poor farmers opt for immediate benefits at the expense of long-term production sustainability. High incomes provide farmers with the ability to purchase materials and tools or hire labour. Some authors (Pearce et al., 1990; Barlow, 1991) argue that farmers with high incomes are associated with low discount rates and therefore are able

to make long-term investments such as soil conservation. Napier (1994) on the other hand argues that high incomes are associated with profit maximizing farmers who have a high discount rate, hence low likelihood of investing in long term ventures such as soil conservation. Off-farm income and access to credit have the potential of increasing liquidity in the household, freeing up resources for investment. When credit markets fail, adoption of conservation measures is limited by farmers' ability to finance the required investment (Lutz et al., 1994). Unfortunately, for soil conservation, it seems that most available and sustainable soil conservation technologies such as terracing and stone lines are capital intensive.

At very low incomes (<1US\$ per day), the household may not adopt soil conservation measures. At a certain high level of household income, a household's profitability of adopting soil conservation increases to a level where additional income will have negligible effect on the profitability of adopting soil conservation. This means that at very low income and at relatively high incomes, the probability of adopting soil conservation practices is unaffected by small changes in income. Income of household has been greatly improved by ADRA (Adventist Development and Relief Agency), an organization supporting farmers in the study area by promoting zero grazing units and poultry production. Livestock provide manure for crop and fodder production.

Household size positively affected adoption of all the soil conservation technologies. The effect however, was not statistically significant for all the technologies contrary to expectation of positive and statistically significant effect of household size on adoption. The average number of people in the households interviewed in the study area is 6 persons. The highest recorded was 12 and the lowest was 2 persons per household.

Household size determines the availability of household labour and labour is important in use of the labour intensive soil conservation technologies such as terracing and stone lines. Own labour is important in subsistence farming in the study area as most people lack incentives to hire labour for subsistence farming as this is associated with low returns. Most of the available family labour work in tea plantations. In the traditional African society, there was self-reliance and social concern for others through a socio-cultural provision to incorporate the young, the old, the poor, and the sick into the society so as to achieve an in built provision for self-reliance for the individual and for the society.

'Catchment' approach uses this prodigy to get labour to conserve soil.

Predominance of collective action in Kericho district suggests existence of social capital that usually results in the transition to sustainable farming. Social capital is a function of the community's ability to cooperate, to learn and to copy mechanism and social norms about good farming. With the progressive breakdown of African self-reliance and social concern for others, labour is beginning to vary from household to household. In the past household labour was freely offered for the welfare of the entire society but currently household labour availability is becoming important in determining adoption of labour intensive technologies because individuals no longer offer free labour for others' welfare.

Labour is an important input because farm households make more frequent allocation decisions about labour than all other resources combined (Graaff, 1996). Adoption of structural soil conservation technologies such as terraces and stone lines require a lot of labour. This explains why household size had positive correlation with household decision to adopt conservation measures. Labour for construction and maintenance of soil conservation structures is important. The household is the main source of labour required in not only soil conservation but also in other farm operations.

A household with a large proportion of adult members is often associated with higher supplies of labor than those with fewer adults. Total number of persons in the household gives an indication of amount human capital available and reflects on household's labor availability potential. A large household size might result in availability of adequate labor. However, resources might be allocated from investment on the farm including soil conservation, to consumption if the household is too large (Childress, 1994). It is assumed that households with large numbers of people have more labor and need more food hence have a need to conserve soil. Availability of labor was crucial in adoption of grass strips and anti-erosion ditches in Rwanda (Clay and Reardon, 1994). In a similar study, Kagwanja (1996) came up with the conclusion that household size negatively affected adoption of bench terraces, grass strips and trees but positively influenced adoption of 'fanya juu' terraces. Labor scarcity is a real constraint in construction of conservation practices. Farm families carry out construction and maintenance activities. The resourceful household members in conservation works are men and youth.

Sex of head of household is a variable known to affect adoption of new technologies. Households with male household decision-makers tended to adopt stone lines, grass strips and terracing while households with female decision-makers showed a tendency to adopt unploughed strips as soil conservation measures among the sampled households. The effect of sex of the decision-maker was statistically significant at 10% level for adoption of stone lines while it was significant at 5% level for unploughed strips. The effect of sex of decision-maker is not significant at 10% on adoption of grass strips and terracing. The many women groups, Self Help and Church groups (whose members are mainly women) in Kericho mobilize resources for the common good of group members. They mainly deal with income generating activities and rarely engage in conservation. Women tend to choose soil conservation technologies which are not labour intensive, easily sustainable and are inexpensive like the grass strips and the unploughed strips. Men on the other hand opt for labour intensive techniques like terraces and stone lines. Capital is not a problem to men because customarily they control family income. Conservation activities do not conflict with women's household chores.

Out of 200 farmers interviewed in this study, 142 were men and 58 were women. Only one woman (1.7%) out of 58 participated in soil conservation activities. The rest (98.3%) were men. Women in the catchment area play a minimal role in conservation. They usually combine conservation activities with their traditional household cores that apparently increase their workload. Women have negative attitudes towards conservation activities, explaining why their participation is low participation. Soil conservation in the area is believed to be an activity that is supposed to be undertaken by men and the youth. The average number of women who attended catchment conservation meetings was usually 2 and all soil conservation meetings usually had a turnout of less than 6 women. Conservation techniques in Kericho are differentiable by gender, suitability and sustainability. Financial constrains and cultural practices are the main factors dictating the techniques applied by women. Women tend to choose techniques which are not labour intensive, easily sustainable and cheap, like use of grass strips, cover cropping, strip cropping and unploughed strips. Men on the other hand, opt for labour intensive techniques like 'fanya juu' and 'fanya chini'.

The results of the study indicate that women's participation in catchment committees is below average. Most catchment committees have between 2 and 5

female members compared to men who are usually more than 7 in each committee. This under representation could be due partly to pressure due to women's traditional household chores and to the local traditional beliefs on secondary role they play in decision making in fora involving men.

Women are more risk averse than men (Mehra, 1995). Furthermore, male decision-makers once convinced to adopt a technology more often do not consult other household members but rather they instruct them to take it up without raising questions. Women play a decisive role in supporting their families. They also determine food availability for consumption and nutritional status of their family members in rural areas. This being the case any strategy to disseminate improved soil conservation technologies must necessarily attempt to reach women. Males headed 91.5% of households interviewed. However, out of the 200 farmers interviewed in this survey more than half of them were women. This is due to migration of men from rural to urban settings for formal employment. Some men had also opted for off-farm wage employment within rural areas and in tea plantations leaving women manage farm production on their own although they may send cash remittances from time to time to supplement rural income.

Frequency of extension visits positively affected adoption of stone lines, grass strips and terracing in this study. The variable negatively affected adoption of unploughed strips. The effect was statistically significant for terracing at 5% level and unploughed strips at 10% level. Agricultural extension is the means by which change agents transmit new agricultural information to farmers. Effectiveness of extension agents is measured in terms of frequency of their visits to farmer's fields, relevance of extension message to farmer's problems and number of farmers who have adopted the technologies promoted by change agents. Extension agents include MoA staff, NGOs, and farmer co-operatives.

Extension effort, though is known to affect the adoption of new technologies in a positive way, did not have the same effect on adoption of unploughed strips in this study. This can be explained by the fact that adoption of unploughed strips does not need a lot of skill. The positive correlation between frequency of extension efforts and adoption of the other technologies is expected because extension is a traditional way of transmitting new information and technology to relevant users especially in agriculture. The non-significance of the extension contact as a variable to adoption of stone lines

and grass strips is attributed to the fact that most farmers are exposed to similar limited extension services. Agricultural extension agents played an important role in decision-making on types of conservation techniques to establish in the study area.

In the study area, most farmers have been mobilized and sensitized on the effects of land degradation and measures to be taken in order to conserve soil, water and plant nutrients. The extent of participation by farmers in soil conservation activities was dependent on the quality and frequency of extension services provided to the farmers. However, extension agent to farmer ratio of 1: 1000 (MoA 2002) in the study area is too low to ensure adequate frequency of extension visits to farmer's fields. There is therefore a need for more extension personnel at various levels in the study area. This will enhance participation of farmers in planning and management of sustainable soil conservation activities in the study area.

Past and present support of conservation efforts has developed a "dependency syndrome" among farmers. Farmers feel it is the duty of GoK (Government of Kenya) to provide soil conservation tools and equipment. Farmers blamed GoK for the slow adoption rate of conservation technologies. Sound technical advice lacked in some cases. Farmers in the upland areas were using di-ammonium phosphate fertilizer when their soils are acidic. In some places farmers were using inappropriate conservation technologies such as "fanya juu" where a stone ridge would be more appropriate. Lack of technical knowledge as well as lack of administrative enforcement, laxity and ignorance worsens the problem of environmental degradation.

Biophysical features of the soil positively affected adoption of all the considered soil conservation practices. This effect is statistically significant at 10% level for terracing, grass strips and stone lines while it is significant at 5% level for unploughed strips. Community participation in soil and water conservation activities varied with biophysical features (such AEZ, soils, and slopes) of the farm. Farmers with sloppy farms participate in conservation more than those with land on less sloppy areas. Choice of appropriate, effective and sustainable structural and agro-techniques for specific areas would depend on slope, soil type, land use type and climate among other factors. Stone lines for example were mainly concentrated in rocky areas of the study area where there are many stones as the major materials used in setting up the structures are stones. The higher prevalence of grass (Napier) strips than unploughed strips on farms is because of the fact that

farmers preferred Napier grass as it provides livestock feed apart from being used in erosion control.

Terrain has a lot of bearing on soil conservation. As slopes increase, the adoption rate of soil conservation technologies is expected to increase. Land parcels that have high soil degradation potential are associated with high levels of soil conservation (Gould et al., 1989; Ervin and Ervin, 1982). Farmers whose farms are on steeper slopes have a higher probability of identifying the need for soil conservation than farmers whose farms are on gent slopes. If factor markets are perfect, characteristics that are likely to be complimentary to conservation investment, such as slope, will lead to greater conservation investment (Pender J. and Kerr J., 1996). However in absence of perfect markets the result is uncertain.

Security of tenure positively affected adoption of all the soil conservation technologies in this study. However the effect was not statistically significant for the adoption of unploughed strips and grass strips. Security of tenure was statistically significant at 10% and 1% levels in affecting adoption of stone lines and terracing respectively.

Land tenure is a system of laws and customs that establish rights and duties relating to land use (Upton, 1987). Farm households generally exercise ownership rights to land. They cultivate and may pass on rights to their sibling depending upon the system of inheritance. It has often been argued that insecure land tenure discourages farmers from undertaking long term investment such as soil conservation technologies (Hardin and Baden, 1977; Lutz et al., 1994; Napier, 1994). This is particularly so for conservation measures such as stone lines and terracing associated with long pay back periods (Mokwunye et al., 1996). Security of tenure is very important in developing countries as indicated by many studies for example by Stahl (1993) in the highlands of East Africa and Ethiopian Highlands where he reported that a major constraint to long term improvement on land is insecure land tenure. Rochleau et al. (1988) observed that land tenure arrangements have a great role in adoption of most technologies such as tree planting since most trees require a long time to grow.

Most farms in the study area have been registered under freehold titles. Public lands are however often subjected to overgrazing, soil mining, and husbandry practices that encourage soil erosion due to lack security of tenure. This is particularly seen in public lands in Kipkelion and Blue hills area where encroachment into more fragile hill slopes have continued unchecked for a long period of time. Communally grazed animals

often destroy soil conservation structures therefore invalidating farmers' efforts.

The most important mode of land acquisition in the study area is by inheritance, land purchase accounting for a smaller proportion. This indicates an inactive land market in the study area which is a typical feature in many parts of Africa (Andre and Platteau, 1998). Supply considerations largely explain why land sale markets are thin in sub-Saharan Africa. "Distress Sales" are rather preferred in describing the supply of land in sub-Saharan Africa (Bardhan, 1984). Most land owners are not willing to sell their land, even when they get employment outside agricultural sector and reside in towns. This is because land is a crucial asset for present and/ or future subsistence of family and is a secure form of holding wealth and a good hedge against inflation. Land sales often happen in distress situations as many people working in urban areas use land as insurance against uncertain employment and against landlessness in the next future generations of the family. Farmers also see it as pension fund for their old days (Lawry, 1993). Social considerations underlie apparent persistence of indigenous control of land transfers even when they are duly registered.

The relationship between tenure and investments is twofold. Under communal land ownership and when institutions governing land ownership are weak, incentive for investment may be created by an established procedure for improving defacto ownership rights through planting of trees (Otsuka et al., 1997). On the other hand as expected, secure land tenure improves investment on land. Matlon (1994) argues that in marginal areas, manuring or improving fertility of soil is a way of enhancing security of land use rights in marginal security situations. Under communal land tenure, resources are over-utilized in the economic sense. This results in low investment in conservation measures (Lynne and Nieuwout, 1990). On the other hand, with restricted access/ private property, incentive to invest is often higher and rates of use lower since cost of resource degradation is internalized. Property rights are also considered to be related to farmers' relative risk aversion (Shively, 1997).

The results indicate that the majority of farmers (94.7%) have private ownership rights. Communally owned land is only 2.6%. A few farmers (2.7%) had either rented in or rented out land. Individualization of land and subsequent subdivision among family members is compelling farmers to intensify their farming systems from subsistence to modern farming so as improve incomes. Individual ownership of land

has eliminated communal grazing that contributes to destruction of conservation structures. The most important form of land acquisition among sampled farmers is by inheritance (75% of all farms). Purchased land makes up 21.5% while rented land is only 2%. This indicates an inactive land market (Andre and Platteau, 1998) in the study area. Newly occupied land (formally not occupied because of reasons such as land being forested) form 1%. Temporary free land (land given out to a household to exploit for agricultural production in kind) accounts for 0.5% of the modes of land acquisition.

Security of tenure is given a lot of priority. Among the sampled households, 75% have land title deeds while 10% are in the process of acquiring them. The rest 15% do not have title deeds. Farm investments in soil conservation are only made when farmers are assured of internalizing benefits for a long period. Insecurity of tenure means that farmers face lower expected returns from soil conservation because of risks of loss of use rights before realizing all benefits arising from investments they have made. This explains the positive relationship between adoption of terracing and stone lines and security of tenure. Insecure property rights dissuade farmers from undertaking long-term investments like soil conservation as they may not reap all benefits to such investments (Ervin, 1986; Wachter, 1992).

Communally owned land is often of public utility and there is no incentive to control soil erosion due to the free-rider problem (Konzacki, 1978). Lyne and Nieuwoudt 1990 argue that under communal land tenure, resources are over-utilized in the economic sense and investment in conservation measures is low. On the other hand with restricted access (private property) the incentive to invest is likely to be higher and rates of utilization lower because the cost of resource degradation is internalized. Property rights are also considered to be related to farmers' relative risk aversion (Shively, 1997).

Farmer's perception of the profitability derived from adoption of the modern soil conservation technologies is a variable that was found to be statistically significant at 1% for unploughed strips and 10% for terracing among the sampled households in his study. The farmer's perception of profitability variable was however not statistically significant in affecting adoption of stone lines and grass strips. To these farmers there was no difference between income and profits. The majority of them considered income received from agricultural produce as profits since costs were rarely included

in evaluating technologies by farmers. This is mainly due to lack of records on resource use and financial transactions throughout the production period. Profitability of use of new technologies was not given any consideration because farmers did not analyse profitability of the farm enterprises. Enterprise selection was guided by output prices, attitudes, cultural and social considerations.

Low income and lack of access to credit together with low literacy levels result in limited funds to invest in soil management and soil conservation technologies in the study area. Economic gains to conservation are not clear to farmers. However, farmers are aware of yield increases due to adoption of soil conservation. Data obtained from farmers in this study indicate that farmers have realized up to 125% yield increases after adopting soil conservation. Integrated crop and livestock production and proper soil management have high payoff as such investments increase farmers' income and reduce soil mining.

Ethnic diversity also has important implications for catchment conservation. There are differences among communities in resource limitations in the project area which bear upon their involvement in conservation activities and the difference in adoption of soil conservation techniques. For instance in Londiani, one community is aware about benefits of conservation and hence is more responsive to conservation initiatives. Differences in financial abilities and sizes of land holdings among communities determine the type of conservation techniques implemented on farms. When other factors are held constant financial ability encourages conservation as such activities usually need high investment costs to undertake conservation.

From this study, it was also observed that some socio-cultural factors, not analysed in this study, seem to influence farmers' decisions on adoption of environmental conservation. These factors include cultural beliefs, norms and values. Women, for example, are not allowed to do certain duties like tree planting and fencing. All trees planted belong to men thus women have to ask for permission to fell any tree for domestic uses. This reduces environmental degradation as women have to seek for permission from men before felling trees. Another check to deforestation is conservation of sacred forests. Londiani's Kipsigis Hill (Tulwab Kipsigis) is a sacred place for male circumcision and other cultural rituals. Therefore, it is well protected and has not been encroached on in terms of human settlement, animal grazing, or deforestation.

Indigenous knowledge and skills like conservation of shade trees, shifting cultivation and shifting of cattle sheds (bomas) to improve land productivity are common in the study area. River bank cultivation was traditionally prohibited and this helped to conserve river banks. Indigenous knowledge can be incorporated into modern conservation techniques. Shifting cultivation for example, is an environmental conservation cultural technique that has been incorporated in to the fallow method of setting aside land for grazing.

Conclusion and recommendations

This study rejected the null hypothesis that farm, farmer and technology characteristics have no significant effects (at $\alpha = 0.1$ level) on adoption and choice of soil conservation technologies among the selected households in Kericho district. This is because from the analysis, adoption of stone lines was significantly affected by security of tenure, income of household, sex of family decision-maker, biophysical features of the farm and education level of head of household (at $\alpha < 0.1$). Adoption of unploughed strips for soil conservation was affected by perception of profitability, sex of family decision-maker, frequency of extension visits, biophysical features of the farm, and education level of decision-maker (at $\alpha < 0.1$). Adoption of grass strips was affected by extension visits, biophysical features of the farm, and farm size (at $\alpha < 0.1$). Adoption of terracing was affected by of decision-maker's age, security of tenure, income, farmers' perception of profitability, extension visits, farm's biophysical features and farm size (at $\alpha < 0.1$).

Improving security of tenure, widening the farmers' income base, promoting education through more frequent extension visits and choosing enterprises with higher profitability, can promote adoption of soil conservation technologies. Gender and age of decision-maker and biophysical features of the farm should also be taken into consideration since they affect choice of technologies to adopt.

To search for appropriate land use planning, this study recommends a research to be carried out to identify land use factors influencing soil degradation. After identifying the factors, econometric techniques can be used to analyze the relationship between soil degradation and the aspects of land use. The major factors include suitability of cropping patterns and cropland conservation techniques. Land productivity sustainability should be assessed in terms of capability, soil

stability and erosion risk. Cropping patterns should consider the benefits of intercropping, and rotating perennial and annual crops in order to optimize on crop productivity. Crop land conservation techniques should be selected on the basis of appropriateness and sustainability according to slope and agro-climatic zone and soil types. The development of land use planning policy in Kenya will provide the necessary framework and guidelines for managing forest land, steep land cultivation and wetlands within the catchment area. Such a policy would provide long-term solutions to the persistent problems of downstream flooding and sedimentation and pollution due to drainage of wet lands within the Nyando catchment area.

There is need to put in place a framework on land use. In Kenya, there is no Act of Parliament that addresses specific environmental concerns associated with bad land use planning and use. In fact, in the current Kenyan constitution, there is no land use planning policy. The Agriculture Act, CAP 318 provides rules for maintenance of stable agriculture, conservation of soil and soil fertility, and stimulating development of agriculture law. The Act defines agriculture as inclusive of dairy farming, livestock breeding and keeping and the use of land. Under section 48, the Act provides "The Agriculture (Basic land Usage) Rules." These rules are specific to the cultivation of land according to slope and to protection of water courses (river banks). Field observation in this study shows that the subdivision and allocation of settlement scheme land was done without land use planning. Lands that were initially earmarked for forest and grazing have been converted into cultivation due to an increasing demand for land. The high and rising population pressure has caused people to encroach the remaining forests and wetlands in the region.

From this research, it was realized that certain aspects affecting soil conservation and more important to farmers need to be researched on. Indigenous knowledge and skills like conservation of shade trees, medicinal trees, shifting cultivation and shifting of cattle shade to spread farm yard manure are useful in management of soil and water resources. River bank cultivation was also traditionally prohibited and this has helped to conserve river banks. Some forests are sacred and hence have not been affected by deforestation. The indigenous knowledge should be investigated and incorporated into modern conservation technologies. Research should then be done to determine economic benefits to such activities as they seem to greatly affect farmers' soil conservation behaviour.

Making it easy for farmers to acquire titles is a step towards environmental conservation. This can be made by reducing costs incurred by farmers in trying to get land title deeds. GoK could subsidise the cost of acquiring land titles. External financing is also necessary in adoption of soil conservation technologies such as terracing. This is because low income is a major cause of limited capital needed in the adoption of the structural soil conservation technologies. The poor extension agent-farmer contact in the study area can be complimented by fact sheets (pamphlets, posters), newscast, radio bulletin, or television spots production. These will improve the farmers' knowledge on promoted technologies. A scientific news service to provide regular, reliable, relevant and timely information on environmental conservation can be sponsored by organizations promoting conservation in Western Kenya. This is possible if the institutions concerned with soil and water conservation collaborate and pool together their financial and other resources.

Acknowledgements

My sincere gratitude goes to my University supervisors Professor Robert J. Okalebo and Professor Henry K. Maritim who guided me through this research and whose invaluable input led to the success of this study. Others are all NGOs and government of Kenya institutions such as Ministry of Agriculture, Ministry of Environment and Natural Resources and others (of Kericho district) who played a very important role especially in providing vital data that was needed to arrive at the conclusions reached at in the study.

References

- Andre, E. and Platteau, A. (1998): "Indigenous Land Use Systems and Investment in Soil Fertility in Burkina Faso," in Searching for Land Tenure Security in Africa. Bruce J. and S. Migot-Adhola (eds). Kendal/Hunt Publishing Company.
- Bardhan P. 1984. Land Labour and Rural Poverty. New York. Columbia Univ. Press.
- Barlow C. 1991. Land Degradation: Development and Breakdown of Terrestrial Environments. London: Cambridge University Press.
- Berger C. 1996. Soil Resources, Management and Conservation Service. Rome: Food and Agriculture Organization.
- Brown R. and Wolf E. 1984. Soil Erosion: Quiet Crisis in the World Economy. World Watch Paper 60. New York: World Watch Institute.
- Childress M. 1994. Capital Investments on Smallholder Coffee Farms: An Empirical Study from Honduras. In: Lutz E., Pagiola S. and Reiche C. (eds). Economic and Institutional Analyses of On-Farm Soil Conservation Projects in Central America and the Caribbean. Environment Paper No. 8. Washington, D.C.: World Bank.
- Clay D. and Reardon T. 1994. Determinants of Farm level Conservation Investments in Rwanda. International association of agricultural economists. Occasional paper No. 7
- De la Briere B. 1999. Determinants of Sustainable Soil Conservation Practices' Adoption. An Analysis for the Dominican Republic Highlands. Paper Presented at the Economic Policy Reforms and Sustainable Land Use in LDCs: Recent Advances in Quantitative Analysis, Wageningen, 30 June– 2 July 1999.
- Ervin D. 1986. Constraints to Practicing Soil Conservation: Land Tenure Relationships. In Stephen B. and Nappier L. (eds) Conserving Soil: Insights from Socio-Economic Research. Ankeny, Iowa: Soil Conservation Society of America.
- Ervin C.A. and Ervin D.E. (1982). Factors affecting the Use of Soil Conservation Practices: Hypothesis, Evidence and Policy Implications. *Land Economics* 58 (3): 277–292.
- Gould B., Saupe and Klemme R. 1989. Conservation Tillage: The Role of Operator Characteristics and Perception of Soil Erosion. *Land Economics* 65: 167–182.
- Graaff J. de 1996. The Price of Soil Erosion; an Economic Evaluation of Soil Conservation and Watershed Management. WOTRO Project No. 45–104. Netherlands: Netherlands Foundation for Advancement of Research (WOTRO).
- Hardin G. and Baden J. 1977. Managing the Commons. San Francisco: Freeman.
- Kagwanja J. 1996. Determinants of Farm-Level Soil Conservation Technology: Lessons from High Rainfall, Highly Populated, Steep Sloped Mt. Kenya Highlands, Embu, Kenya. Ph.D Dissertation. University of Missouri – Columbia.
- Konzacki Z. 1978. The Economics of Pastoralism: A case of Sub-Saharan Africa. Frank Cass, London, p.145.
- Lawry S. 1993. Transactions in Cropland Held under Customary Tenure in Lesotho. In: Bassett T. and Crummy D. (eds) Land in African Agrarian Systems. Madison. University of Wisconsin Press. pp 57–74.
- Lutz E., Pagiola S. and Reiche C. 1994. The Costs and Benefits of Soil Conservation: the Farmer's View Point. *The World Bank Research Observer* 9 (2): 273–295.
- Lynne M. and Nieuwout W. 1990. The Real Tragedy of the Commons: Livestock Production in KwaZulu. *Journal of Agricultural Economics* 70: 12–19.
- Matlon P. 1994. Indigenous Land Use Systems and Investment in Soil Fertility in Burkina Faso. In Searching for Land Tenure Security in Africa. Bruce J. and Migot-Adhola S. (eds). Kendal / Hunt Publishing Company.
- Mehra R. 1995. Raising Agricultural Productivity. The Role of Women Farmers. In: Peters G.H. and Hedley D.D. (eds). Agricultural Competitiveness: Marketing Forces and Policy Choice: Proceedings of 22nd International Conference of Agric., Economists, held in Harare, Zimbabwe, 22–29, Aug., 1994. Dartmouth, England.
- Mokwunye A., Jags A. de and Smaling E.M.A. (ed.) 1996. Restoring and Maintaining the Productivity of W. African Soils: Key to Sustainable Development. Misc. Fertilizer Studies 14. International Fertilizer Development Center of Africa, Lome, Togo.

- Napier T. 1994. Socio-Economic Factors Affecting Adoption of Soil and Water Conservation Practices in Lesser Scale Societies. Paper Presented at the Intern. Symposium on Wind Erosion in West Africa, Stuttgart, Germany, Dec., 1994.
- Odendo, M. (2000). Economics of Soil Conservation in Vihiga District. M. Phil. Thesis, Moi University, Eldoret.
- Otsuka K., Suyato S. and Tomich T. 1997. Does Land Tenure Insecurity Discourage Tree Planting? Evolution of Customary Land Tenure and Agroforestry Management in Sumatra. Washington, IFPRI EPTD Discussion Paper No. 31.
- Pearce D., Barbier E. and Markanya 1990. Sustainable Development: Economics and Environment in the Third World. London: Edward Elgar Publishing Ltd.
- Pender J. and Kerr J. (1996). Determinants of farmers' indigenous soil and water conservation investments in India's semi-arid Tropics. Environment and production Technology Division, International Food Policy and Research Institute; EPTD Discussion Paper No. 17.
- Rocheleau D., Webber F. and Field-Juma A. 1988. Agroforestry in Dry Land Africa. Nairobi, Kenya: ICRAF.
- Scoones I., Reij P. and Toulmin C. 1996. Sustaining the Soil: Indigenous Soil and Water Conservation in Africa. Gate Keeper Series No. 67. London: IIED.
- Shiferaw B. and Holden S. 1998. Resource Degradation and Adoption of Land Conservation Technologies in the Ethiopia Highlands: A Case Study in Andit Tid, North Shewa', Agricultural Economics 18(3): 233-248.
- Shively G. 1997. Assets, Attitudes, Beliefs and Behaviour: Explaining Patterns of Soil Conservation Adoption among Low Income Farmers. Internal Paper Dept. of Agricultural Economics, Purdue University.
- SPSS 2001. Statistical Package for Social Sciences (SPSS/PC+). Advanced Statistical Version 11.5. Chicago, Illinois: SPSS Inc.
- Stahl (1993): Sustainable Agricultural Growth for the Highlands of East and Central Africa: Prospects to 2020. *International Food Policy Research Institute*, Washington D.C.
- Thompson J. and Petty N. 1996. Sustainability Indicators and Soil Conservation: A Participatory Impact Study and Self Evaluation of the Catchment Approach of the Ministry of Agriculture, Kenya. *Journal of Soil and Water Conservation* Vol. 51 (4): 381-385.
- Tiffen M., Mortimore M. and Gichuki F. 1994. More People Less Erosion. New York: Wiley, Walker.
- Upton M. 1987. African Farm Management. London: Cambridge University Press.
- Wachter D. 1992. Land Tilting for Land Conservation in Developing Countries. Environment Department Divisional Working Paper 1992-28. World Bank, Washington, D.C.

Market Integration and Conduct Analysis: An Application to Cattle Markets in Uasin Gishu District, Kenya

Serem A.K*, Maritim H.K, Kipsat M., Kisinyo P. and Nyangweso P.

Moi University, Department of Agricultural Resource Economics and Management; P.O. Box 1125, Eldoret, Kenya, Tel. +254 20 720 124424; *Correspondence Author Email: cserrem@yahoo.com

Abstract

This study aimed at firstly testing whether cattle markets in Kenya are related in the long term. Secondly it was aimed at testing whether the markets have a system of control that dictates market behaviour and price formation. Thirdly the study aimed at contributing towards a better way of conceptualizing agricultural markets in a developing country set up. Secondary time series monthly price data of cattle for a period of 27 months from various cattle markets were collected and analysed using the Co-integration analysis method. Other data was collected through depth interviews. This data was analysed descriptively. The results showed that three of the cattle markets are integrated. It was additionally found that prices tend to be supply driven rather than demand driven. The study also showed that the markets are controlled by established traders through control of information flow, economic control and monopoly over butcheries as well as end product market channels. The traders also practice some form of sales promotion, coordination and predatory or exclusionary tactics directed against established rivals or potential entrants. With respect to control of markets, the difficult circumstances in which traders operate dictate their “modus operandi” as it were. Although these traders play a good role in marketing, their actions prevent equitable distribution of wealth. This in turn is reflected in the form of unexploited potentials in existing markets since existing markets cease to function as efficient generators and distributors of wealth

Key words: Cattle markets, Control, Integration, Prices, Traders

Introduction

Agriculture contributes significantly to the Kenyan economy. The sector contributed to 25% of GDP in 2003 (GOK, 2004). Nyangito (1999) reports that it employs 75% of the labour force, is a major foreign exchange earner and provides nearly all food requirements for the nation. Within agriculture, the livestock sub-sector has a significant contribution to the national economic performance. The country is endowed with suitable environmental factors that support livestock production. All the populations that inhabit the arid and semi-arid areas and most of those that inhabit the higher potential areas have, for an immemorable period of time, owed their livelihood to livestock. Livestock is a source

of food, income and wealth in addition to cultural contributions such as dowry (Argwings-Kodhek, 2001).

The livestock sub-sector in the country has had its own share of problems in the past. The Government at independence clearly identified the sub-sector as playing a crucial role in development. Policies regarding production, disease control and marketing were then put into place to support the sub-sector. The system worked well in the 1960's, 1970's and 1980's. In the 1990's, the systems started showing some weaknesses. Apparently the country's policy framework fell out of tune with the rapidly changing world economic environment. The trend in the world in the 1990's was towards privatization, efficiency and competition (Argwings-Kodhek, 2001).

The objectives of the study were (1) to analyse existing livestock marketing price data in Kenya using the co-integration price analysis, (2) to find out whether there is evidence of structural and behavioural power patterns in the livestock markets of Kenya, (3) to perform a conduct study in the livestock markets of Kenya, and, (4) to contribute towards a need for better ways of conceptualizing agricultural marketing in a low income developing country context.

The study hypothesised that there is a long run integration in Kenya livestock markets, power pervades the trading system and dictates the trading behaviour, and that the character of trading behaviour and price determination is influenced by a psychology of uncertainty.

Methodology

Secondary data was collected from the Ministry of Livestock Development in Uasin Gishu district and Ministry of Livestock Development headquarters as well as other sources like the county councils. This data was analysed using the co-integration analysis method. Other data was collected through informal discussions with traders. The approach of data collection recommended by Harriss-White (1999) was used. This data was collected in four markets of Uasin Gishu District that have been known to trade in livestock for a considerable period of time. A total of 60 traders were identified for this exercise. These traders were interviewed to get information about them as individuals and how they conduct their trade. They were also monitored over a period of four months in order to observe their strategies in trading. The four markets identified

were also monitored for a four month period in order to observe how transactions are performed. The tool of data collection was checklist that was used to guide the interviews.

The secondary data collected was used to test the hypothesis of long-term market integration. The data collected was average cattle monthly market prices between months of January 2001 and April 2003. The markets targeted were those of Moiben, Turbo, Kapseret, Soy and Kesses Divisions. The prices were quoted at Kenya Shillings (Kshs) per animal. This data was then deflated to convert them to real prices by using the consumer price indices (CPI). The resultant real prices were then subjected to co-integration analysis process using microfit 4.0 analytical programme (Pesaran and Pesaran, 1997).

Results and discussion

Co-integration analysis results

The results indicate a close relation between Moiben, Turbo, Kapseret and Kesses cattle prices (Fig. 1). The Soy prices seem to behave quite independently. It can also be observed that the real prices have gone down with time in all markets.

Figure 2 shows differenced prices and indicate a very wide fluctuation in Moiben prices. All the markets however exhibit a balanced fluctuation in the prices around the mean price.

Testing for stationarity using unit root tests

The objective of performing a stationarity test is to determine whether the individual time series market

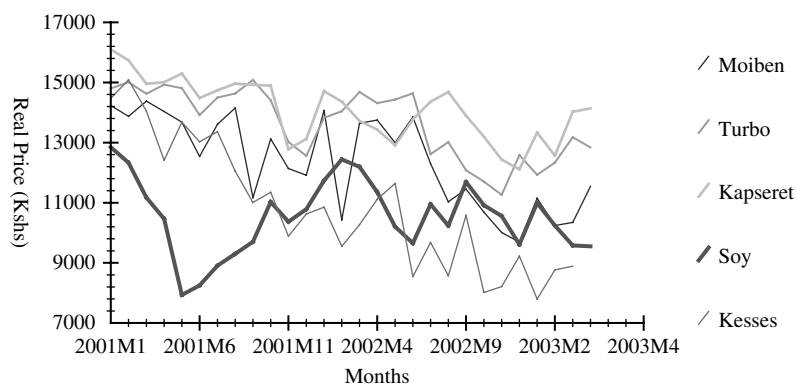

Figure 1. Real Monthly Cattle Prices for Markets in Uasin Gishu District.

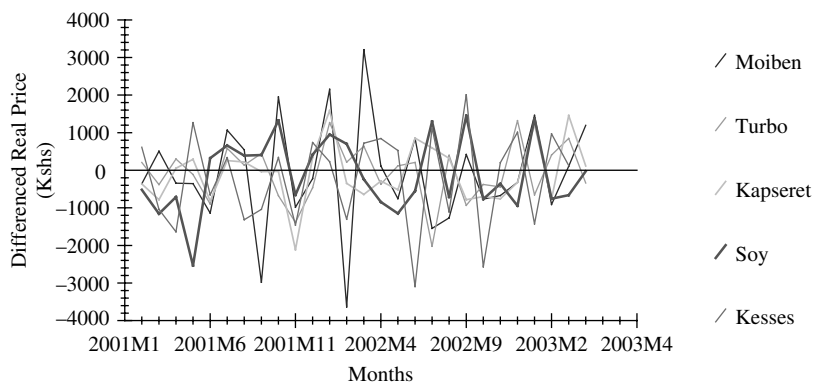

Figure 2. Differenced Monthly Cattle Prices for Markets in Uasin Gishu District.

prices are integrated of order one. If this condition is satisfied, then it means the other steps that lead to a satisfactory test of co-integration can then follow. To test for stationarity using unit root tests, the Augmented Dickey-Fuller test procedure was used. The software used for this procedure is the Microfit 4.0 software.

The results indicate that Moiben, Turbo, Kapseret and Kesses prices are integrated of order one while Soy prices are not integrated of order one. The Soy prices were therefore not subjected to co-integration analysis tests using Johansen’s (1995) method.

Test of co-integration using Johansen’s test

Johansen’s test is usually performed to test for the existence of co-integration between various prices. It makes use of the Vector Autoregressive (VAR) process. It involves selection of the order of the VAR model. The three tests are not explicit on the number of co-integrating vectors. The co-integration Long Run (LR) Test Based on Maximal Eigen value of the Stochastic Matrix test indicates that there is one co-integrating vector. The Co-integration LR Test Based on Trace of the Stochastic Matrix test also indicates that there is one co-integrating vector. The model selection criteria however indicates that when the Akaike Information Criterion (AIC) is used, there are three co-integrating vectors and when the Schwartz Bayesian Criterion (SBC) is used, there is one co-integrating vector. It can therefore be concluded that the prices are fairly co-integrated.

The Error Correction Model Test (ECM)

The purpose of this test is to show the direction and strength of the relationship between various prices.

Table 1. Error Correction Model Matrix showing the coefficients and T-statistics for Moiben, Turbo, Kapseret, and Kesses Divisions

Matrix II	Moiben _{t-1}	Turbo _{t-1}	Kapseret _{t-1}	Kesses _{t-1}
Δ Moiben	-1.16 (-6.75)	0.75 (6.75)	-0.66 (-6.75)	0.64 (6.75)
Δ Turbo	-0.18 (-1.20)	0.11 (1.20)	-0.10 (1.20)	0.10 (1.20)
Δ Kapseret	-0.16 (-1.05)	0.11 (1.05)	-0.09 (-1.05)	0.09 (1.05)
Δ Kesses	0.19 (0.77)	-0.12 (-0.77)	0.11 (0.77)	-0.11 (-0.77)

The ordinary least squares (OLS) method is utilized to determine the coefficients and to test the significance of the relationship between various price series.

Table 1 shows the results of the error correction model.

The table shows the coefficients of the relationship between the various prices. The figures in brackets are the T-statistic. These results show that there is a strong long term relationship between Moiben prices and all the other markets. This is indicated by the significant T-statistics shown in the first row. All the other markets; Turbo, Kapseret and Kesses do not show a strong long term causal relationship with the other markets as shown by the T-statistics in the other rows in the table above.

Impulse response analysis

Impulse response analysis is carried out in order to perform a sensitivity analysis on the prices. The results are shown in the generalized impulse analysis results on Figure 3 a, b, c and d.

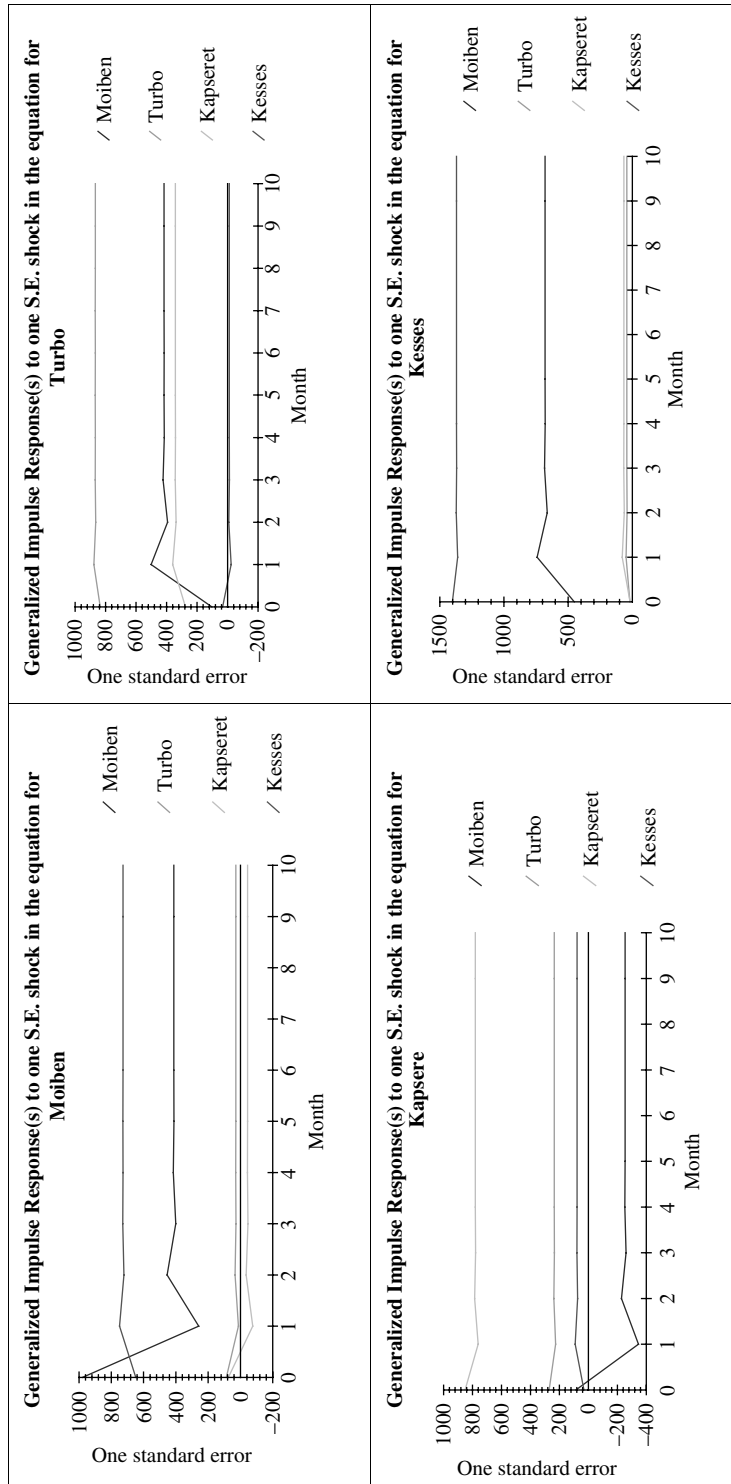

Figure 3. Impulse Analysis Results.

The figures above show that when the prices in Moiben increase, the prices in Kesses also increase marginally. All the other prices are not responsive. When the prices in Turbo increase, the prices in Moiben and Kapseret also increase, all the other markets do not respond. When the prices in Kapseret increase, the prices in Kesses also increase. All the other markets do not respond. When the prices in Kesses increase, the prices in Moiben, Turbo and Kapseret also increase.

From the results, it was found that cattle markets in Uasin Gishu district are co-integrated in the long run. The results indicate that four markets out of the five markets whose data were analysed showed existence of price integration. The graphical analysis results showed similar movement in direction of prices with time as well as a fairly equal distribution of prices around the mean for the differenced prices. The Augmented Dickey Fuller (ADF) test indicated that the individual price series in four out of the five markets were integrated of order one. Only Soy prices were not integrated of order one while Moiben, Turbo, Kapseret and Kesses markets were integrated of order one. The error correction model showed that Moiben prices significantly influences its own subsequent prices, prices in Turbo, Kapseret and Kesses. The Moiben prices positively influenced Turbo and Kesses prices but negatively influenced its own subsequent prices and those of Kapseret. The generalised impulse response analysis indicated that when a shock was applied to the Moiben prices, Kesses prices responded positively. When it was applied to Turbo prices, Moiben and Kapseret prices responded positively. When it was applied to Kapseret prices, Kesses prices responded positively and when it was applied to Kesses prices, Moiben, Turbo and Kapseret prices responded positively.

It was concluded that cattle markets in Uasin Gishu district showed some price integration although its strength varied. The existence of a close relationship in these markets was considered to be probably because of the good condition of roads in the district. Most of the traders also visited all the markets in the district and could therefore relate prices in the various markets. All the markets in the district channelled most of its products to Eldoret town which implied that the demand situation in the town would be reflected simultaneously in all the other markets.

It was also found that traders have some characteristics which gave them power over others. These include age, education and experience in trade. Both behavioural and structural power systems of control

exist as well. Structural control manifested itself in the control of assets such as butcheries, ownership of land, possession of mobile telephones and holding yards. Behavioural control manifested itself in the form of trying to control the psychology of other traders through misinformation, and open display of symbolism such as cars and good dressing to portray a picture of class.

Other behavioural patterns that portrayed power included the application of the principle of holism. This was observed to occur through traders combining their activities so as to gain more control over trade. They pooled together their money, shared the costs incurred in trading, allocated themselves chores to perform and finally shared the profits and losses. They seemed to understand that when they traded together, their activities gained some extra power which they would not have as individuals.

Holism was also seen to operate on individual basis when separate operations of the trading business are integrated so that the individual has control over a wider area and greater volumes of cattle. This kind of combination of activities requires a substantial amount of time, money and discipline. Apparently, traders who have survived the hard economic times have utilized the concept of holism.

Conclusions and recommendations

The existence of a close relationship between various markets implies that these markets can be modeled together. It also implies that information flow is fairly fast. The existence of a system of control implies that any policy intervention has to recognize the existence of these control structures. The conduct study results indicate that the traders are quite rational in their trading behaviour. Following from the analysis and conclusions, it is imperative that financial and legal institutional frameworks needs are enhanced so as to make the cattle trading business more predictable and progressive. It is also worthwhile looking at the issue of quarantines in a more rational manner because it tends to inhibit growth of cattle trading. Structures for data collection and storage also need to put in place including training of personnel on appropriate data collection procedures and what type of data to collect. There is need to also focus future research in this area on utilizing weekly price data for prolonged periods of time in addition to quantification of the number of animals that flow through the cattle markets on periodic basis.

The scope of such a study should in future be widened to cover a wider region.

Acknowledgements

I would like to acknowledge the financial support of the German Academic Exchange Service (DAAD) for enabling me undertake a Ph.D study whose results form part of this paper. I would also like to thank Prof. Henry Maritim, Mary Kipsat, Peter Kisinyo, Phillip Nyangweso all from Moi University, Kenya and Prof. Gunter Lorenzl of Humboldt University of Berlin, Germany for their untiring support in developing this paper. Lastly, I would like to thank AfNet for giving us the opportunity to publish in their proceedings.

References

- Argwings-Kodhek G. 2001. Kenya's Agriculture Sector: The Star That Does Not Shine. In: Institute of Economic Affairs Society for International Development (ed.): Kenya at the Crossroads. Research Compendium. Nairobi:29-57
- GOK, 2004. Economic Survey. Nairobi
- Harriss-White B. 1999. Agricultural Markets from Theory to Practice: Field Experience in Developing Countries. Oxford
- Johansen S. 1995. Likelihood-Based Inference in Co-integrated Vector Autoregressive Models. Advanced Texts in Econometrics. New York.
- Nyangito H.N. 1999. Agricultural Sector Performance in a Changing Policy Environment. In: Kimuyu, P., Wagacha, M. and Abagi, O. (eds): Kenya's Strategic Policies for The 21st Century. Nairobi: 129-162
- Pesaran M. and Pesaran B. 1997. Working With Microfit 4.0. Oxford

Factors determining integrated soil fertility management in central Kenya highlands: Participatory Learning and Action (PLAR) model analysis

Odera M.M.^{*1}, Kimani S.K.¹, Esilaba A.O.¹, Kaiyare J.M.¹, Mwangi E.² and Gachanja E.²

^{*1}Corresponding Author: KARI-Muguga South Station, P.O. Box 30148-00100, NAIROBI, Tel: 254-66-32881-4; Cell Phone 254-722-328563/254-733-685808, E-mail: mikemako67@yahoo.com; ²Ministry of Agriculture, Kirinyaga, Kenya

Abstract

This paper presents the results of a participatory learning and action research (PLAR) model analysis of factors determining integrated soil fertility management among subsistence smallholders in central highlands of Kenya. The data was collected during three days PLAR model guided focus group discussions in Mukanduini village of Central division of Kirinyaga district in Kenya. The objectives of the study were: (i) to guide farmers through participatory identification and ranking of key socio-economic and bio-physical factors that influence integrated soil fertility management (ISFM), and (ii) to guide farmers through participatory identification and ranking of probable solutions to identified problems.

The PLAR model analysis of the study was able to categorize the farmers in the village into three groups on the basis of existing ISFM on their farm holdings, and on wealth status. The key community-level factors constraining ISFM were: rainfall/moisture, low crop yields, poor markets, and low livestock yields. The farm-level factors constraining ISFM were identified to be: lack of proper soil and water conservation methods, lack of adequate soil nutrient amelioration, improper soil residue management, and poor tillage systems. Suggested solutions included increased use of inorganic fertilizers, optimal quantities of organic inputs, proper management and use of crop residues, incorporation of agroforestry species in cropping system, practicing crop rotation, installation of soil and water conservation measures, deep tillage, and planting crops like cassava and sweet potato, which give reasonable crop yields in poor soils.

Key words: Smallholder farmers, PLAR model, ISFM, constraints and solutions

Introduction

This paper presents the results of Participatory Research and Action Learning (PLAR) that was conducted during three days intensive village-level activities that involved participation of farmers in proposed Mukanduini NALEP focal area, Ministry of Agriculture Extension Officers in Kirinyaga District, and Research Scientists from KARI's Muguga South Station. The PLAR served to generate the initial background data that was deemed useful in guiding the proposed demonstrations and farmer uptake analysis of improved soil fertility management practices in the village for the subsequent five growing seasons.

The key aspects addressed during the PLAR included the following:

- Participatory community-level problem identification and listing
- Participatory pair-wise ranking of the general community problems in order of importance
- Participatory pair-wise ranking of the community – level general problems
- Participatory identification and listing of potential solutions to identified community-level general problems
- Participatory identification and listing of problem-specific solutions for the identified problems

- Participatory identification of indicators of wealth
- Participatory pair-wise ranking of indicators of wealth
- Participatory identification and ranking of important tree species
- PRA methods that characterised key socio-economic aspects of the village

The objectives of the Participatory Learning and Action Research Activities were to:

- Identify and rank key socio-economic variables that might have significant influence on sustainable soil fertility management in the target village
- Identify and rank probable solutions to constraints on sustainable soil fertility management in the target village

Methodology

The participatory learning activities were organised around focused group discussion methodology. The frontline extension officer in the target village identified the key informants in the village who were then requested to help in assembling of village members at a centralised Catholic Church cum Nursery School compound for the learning activities. The research team from KARI together with Ministry of Agriculture Staff from the District, Division and Location then guided the assembled farmers into problem/constraints identification, ranking, and proposition of viable solutions to identified problems/constraints. The outcome of the discussions was recorded and forms the basis of the current paper. The approach and sequence of data gathering was based on resource guide manuals for participatory learning and action research (Defoer et al. 2000).

Results

Socioeconomic characteristics of Mukanduini village

Land ownership and use systems

Majority of the farmers are owners of the land parcels on which they farm, only few people lease land from neighbours. Majority of those who lease land from the village are outsiders. There was general decreasing trend in the individual farm holdings mainly due to sub-divisions. Some farmers owned land outside the focal area. Maize based land use-system was the most

predominant. For every unit of land area under crop, maize occupied two-thirds. Only the homesteads were the only non-cultivated portions of the land. The study found out that no land had been set aside for cattle grazing.

Sources of income and expenditure patterns

The major sources of income in the village included sale of food and cash crops, employment, business, and provision of services such as ox-drawn carts. Table 1 below gives proportionate contributions of various sources of income to overall farm-family income. Farm-based enterprises contributed the highest proportion towards family income (approximately 72%) with only 28% come from employment, business and provision of paid services. The income was used mainly to meet household needs such as purchase of soap, salt, clothes, fuel energy, and food mainly meat. The second highest expenditure that ate into the household income was payment of school fees.

Labour sources and demand profile

The average family size in the village was five persons per farm-family. The family provided the highest proportion of farm labour. Casual labour was rarely engaged unless under conditions of extremely high labour demand. School going children also helped with farm work and other household chores such as cooking, looking after animals and fetching water.

Over 90% of daily family labour supply went to farming activities. The labour requirement for farming

Table 1. Contributions to overall family income

Source of Income	Contribution on Scale of 50	Percentage
Maize/Beans	12	24
Tomato	6	12
Ox-plough	4	8
Business	4	8
Employment	6	12
Bananas	3	6
Coffee	2	4
Avocado	2	4
Mango	1	2
Pawpaw	1	2
Sweet Potato	3	6
French Beans	5	10
Cassava	1	2

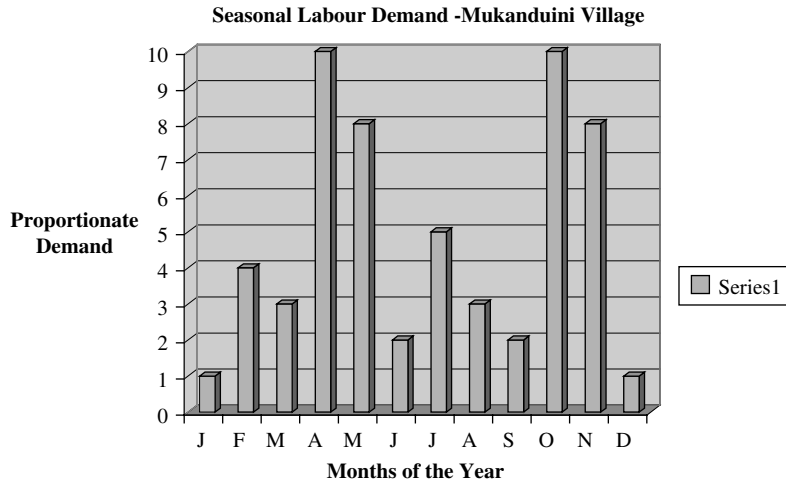

Figure 1. Demand for Labour Across the Year

activities varied across the calendar year with weeding time in April and October comprising periods with the highest demand. Harvesting, land preparation and planting (in descending order) are other activities with high demand for labour. Figure 1 below gives the proportionate demand for labour across the calendar year.

The gendered analysis of decision making at household level revealed that farming related decision making was arrived at collectively where both man, woman and children play active roles. However, the male had more say compared to other members of the family when it comes to making the final decision. All members of the family participated in implementation of what had been decided on.

Community-level problem identification and listing

This activity involved participatory problem identification where the farming community in proposed Mukanduini NALEP focal area played the lead role in identification of general, community-level problems. The problems were then listed down with the aid of either one of the extension officers or the research scientists from KARI. The identified problems included the following: Water shortage for both domestic use and irrigation, poor market outlets for the farm produce, poor soil fertility status, crop pests and diseases, lack of access to “land locked” farms, lack of reliable Artificial Insemination (AI) services, low quality and at times counterfeit planting seed and disease and pest control chemicals, human diseases, lack of reliable veterinary services, lack of reliable extension services, high

price of farm inputs, which make such inputs to be un-affordable to majority of the farmers, lack of tree nurseries, lack of electricity, lack of security, low crop yields and low livestock yields.

On the basis of the identified and listed general community-level problems, the farmers were asked to rank some of the most important problems on the basis of their importance to their general welfare and farming activities. The general rankings in order of importance indicated that water shortage was the most important problem followed by poor market outlets for farm produce, low crop yields, low livestock yields, human diseases, lack of security, and lack of access to what was being referred to as “land-locked” farms

The foregoing activity was then followed by pair-wise scoring and ranking of the selected most important problems, which yielded the following results as indicated in Figure 1.

On the basis of pair-wise ranking of general community problems, water shortage (WS) for both domestic use and irrigation emerged as the most highly ranked problem in the community. This was closely followed by low crop yield (LCY), poor market outlets (PM) for the farm produce, low livestock yields (LLY), human diseases (HD), lack of security (LS) and the least ranked problem was lack of access to land-locked farms (LLF).

The process identification and listing of potential solutions to identified and ranked community-level problems was also participatory with the farmers taking the lead in identification of probable solutions. The identified potential solutions to identified problems were as discussed below

Water shortage

The solutions to water shortage included sinking of bore holes by individuals or community, revival of BrADIways water project by the community, feasibility study for irrigation water by Mukanduini self-help Group, roof water catchment by individual farmers, run-off water harvesting

Poor markets

The solutions to poor markets for farm produce included organised market groups, storage during glut, agro-processing, and, access to adequate market information

Low crop yields

Solutions to low crop yields included improve soil fertility through manuring, soil conservation, use of crop residue, crop rotation, deep tillage and use of inorganic fertilisers, disease and pest control, and, revival of agricultural inputs credit schemes

Low livestock yields

In solving livestock related problems the following solutions were identified pest and disease control through revival of dips, improvement of AI services through revival of cost sharing in provision of the service, improve fodder production and conservation, improved housing for rabbits and poultry, and, improved breeding for dairy goats

Human diseases

Solutions to human diseases were identified as improvement of the services offered at Kianjege Dispensary, enhanced campaigns on use of treated mosquito nets, boiling of drinking water and the improvement of standards of pit latrines “Wimanye”

Soil fertility management issues – constraints and probable solutions

After identifying the community-level general problems, ranking them and proposing of potential solutions, the team embarked on activities relating to soil fertility management issues. The team started by

participatory drawing of village map where one of the farmers did the actual drawing of the sketch with the help of other farmers who were present. The map captured key feeder-rADI communication system, important features such as churches, water points, and homes of people who live next to major junctions in the village. The villagers also helped to identify and categorise the soil fertility characteristics in the village. This latter activity yielded three major categories of soil on the basis of fertility, which were: Good, Moderate and Poor. The farmers were able to demarcate these soil fertility categories on the village map (Ref. Appendix on the Village Map).

The study team guided the farmers into listing down what they perceived as soil fertility decline symptoms. The perceived symptoms for soil fertility decline were as follows:

- Low and declining yields (from say 10 bags of maize per acre to 2.5 bags per acre)
- Poor performance of certain crops such as citrus, pigeon pea, bananas, arrow roots and pumpkins
- Dominance of some weed species (*Mwarachiau*) in spots with low soil fertility
- Change in soil colour (from dark colour to reddish)
- Change in the colour of crops – for the case of maize colour change from green to yellowish and purplish
- Increased disease incidences
- Increased pest incidences
- Declining soil water holding capacity – soil becomes finer

After listing down what they perceived to be symptoms of soil fertility decline, the farmers were once again guided into identifying and listing the major causes of soil fertility decline in their individual farm holdings and the village in general. Their perceived causes of soil fertility decline were as follows:

- Soil degradation and runoff as a result of both water and wind erosion
- Continuous cultivation without adequate soil nutrient replenishment
- Use of inadequate organic soil nutrient sources on the farm holdings
- Improper crop residue management through practices such as burning of the crop residue or selling the residue and thus, failing to return the same to the farm holdings
- Poor tillage practices that result in formation of “hard pans”

Table 2c. Pair-wise ranking of

	AFP	ELP	DT	SCORE	RANK
AFP		AFP	AFP	2	1
ELP			ELP	1	2
DT				0	3

The underlying limitations to adoption of such practices were identified to be:

- Financial constraints
- Inadequate knowledge concerning some of the practices
- Attitude problem that revolves around laziness
- Lack of appropriate tools such as jembes, forks and spades for deep tillage and conservation practices
- Financial constraints that restrict purchase of tree seedlings and thus adoption of agroforestry practices. There is also lack of knowledge on the most suitable species
- Low livestock density in the area, which implies low production manure.
- A general wrong attitude that “fertilisers destroy the soil”

The farmers’ were once again guided into prioritising and ranking of the identified soil fertility enhancing management practices. Table 2b below gives the results of the participatory pair-wise ranking of the practices.

Because three of the soil fertility management practices namely: use of crop residue, agroforestry practices and deep land tillage tied in the ranking, secondary ranking of the three practices was done and the results were as given in Table 2c below.

On the basis of the results of second ranking, the overall ranking turns out to be the way it is represented in Table 3 below.

The farmers were guided into identifying and ranking of causes of decline in soil fertility (Table 4). The following were identified as major causes of soil fertility:

- Soil erosion
- Continuous cultivation
- Inadequate organic matter
- Improper crop rotation practices
- Poor land tillage practices
- Use of inappropriate mineral fertilizers
- Poor organic matter management practices

The participating farmers were guided into identifying the indicators of wealth in the village (Table 5). The following were identified as indicators of wealth:

- Ownership of livestock
- Ownership of animal drawn equipment
- House type
- Type of crop enterprises on ones farm
- Level of farm inputs use
- Land size
- General level of education in the household
- Mode of transport owned and frequently used by the members the household
- Marital status of the head of the household
- Membership to social organisations
- Source of domestic water used by the household

On the basis of the ranked indicators of wealth, the overall level of education of the members of the family emerged as the most highly ranked indicator of wealth. This was closely followed by the marital status of the household head. Source of domestic water was ranked third, while ability to hire extra labour came fourth. The least ranked indicators of wealth were membership to social organization and ownership of livestock.

Table 3. Overall Ranking of Soil Fertility Enhancing Management Practices

Management Practice	SC	RCR	AFP	UM	CR	ELP	UMF	DT	S	R
Soil Conservation (SC)		SC	SC	SC	SC	SC	SC	SC	7	1
Return of Crop Residue (RCR)			RCR	UM	RCR	RCR	RCR	RCR	5	3
Agroforestry Practices (AFP)				UM	CR	ELP	AFP	AFP	2	5*
Use of Manure (UM)					UM	UM	UM	UM	6	2
Crop Rotation (CR)						CR	CR	CR	4	4
Early Land Preparation (ELP)							ELP	DT	2	6*
Use of Mineral Fertilizer (UMF)								DT	0	8
Deep Tillage (DT)									2	7*

Key: * = Arrived at after a second round of ranking

Table 4. Pair-wise Ranking of Causes of overall Decline in soil fertility

Causes of Fertility Decline	SE	CC	IOM	ICRP	PTP	UIF	POM	Score	Rank
Soil Erosion (SE)	SE	SE	SE	SE	SE	SE	SE	6	1
Continuous Cultivation (CC)		CC	CC	PTP	UIF	CC		3	4
In-adequate Organic Matter (IOM)			ICRP	PTP	UIF	POM		0	7
Improper Crop Rotation Practices (ICRP)				ICRP	UIF	POM		2	5
Poor Tillage Practices (PTP)					UIF	POM		2	6
Use of in-appropriate Fertilizer (UIF)						POM		4	3*
Poor Organic Matter Management(POM)								4	2*

*The two causes of fertility depletion tied on scores and the farmers decided that poor management of organic matter was a more serious problem compared to use of in appropriate fertilizer.

Table 5. Pair-wise Ranking of Indicators of Wealth in Mukanduini Village, Kirinyaga District

Indicators of Wealth	OL	ADI	HT	TCE	LIU	LS	EL	MOT	MS	MSG	SDW	LA	Score	Rank
Ownership of Livestock (OL)	ADI	HT	TCE	LIU	LS	EL	MOT	MS	OL	SDW	LA		1	11
Animal Drawn Impl. (ADI)		HT	TCE	LIU	LS	EL	ADI	MS	ADI	SDW	LA		3	9
House type (HT)			HT	HT	LS	EL	HT	HT	HT	SDW	LA		7	5
Type of Crop Enterprise				TCE	LS	EL	MOT	MS	TCE	SDW	LA		4	7
Level of Input Use (LIU)					LS	EL	MOT	MS	LIU	SDW	LA		3	10
Land Size (LS)						EL	LS	MS	LS	SDW	LA		7	6
Education Level (EL)							EL	LS	MS	LS	SDW	LA	7	
Mode of Transport (MOT)								MS	MOT	SDW	LA		4	8
Marital Status (MS)									MS	MS	MS		10	2
Membership Social Org										SDW	LA		0	12
Source domestic water (SDW)											SDW		9	3
Labour Affordability (LA)													8	4

Conclusion

The participatory study was able to successfully identify and rank the village level problems. This will prove valuable in design of viable strategies for sustainable soil fertility management. The study was also able to identify and rank sources of decline in soil fertility. This will help in identifying points of intervention in overall soil fertility decline amelioration. The study also managed to identify probable solutions to causes of soil fertility decline. This will help in coming up with viable recommendations for fertility replenishment in view of the farmers' resource base position and management ability.

In general the PLAR exercise has managed to offer objective background information that will prove quite valuable in achievement of the objectives of the long-term project objectives that seeks to address issues relating to integrated soil fertility management in the target village.

Acknowledgement

We acknowledge the kind co-operation that the study team received from the village members of Mukanduini. The extension staff of the Ministry of Agriculture played a key role in mobilizing farmers and in actual execution of the PLAR exercise. The administration at NARC-Muguga facilitated the transport and subsistence logistics. The project is being implemented with a grant support from The Rockefeller Foundation, USA.

References

- Defoer T., Budelman A., Toulmin C. and Carter S.E., 2000. Building Common Knowledge. A resource Guide for Participatory Learning and Action Research (PLAR). In: Defoer T. and Budelman A. (eds). Managing Soil Fertility in Tropics: A resource Guide for Participatory Learning and Action Research. Royal Tropical Institute, Amsterdam, The Netherlands/ International Institute for Environment and Development, London, U.K.

Spatial Pricing Efficiency and Regional Market Integration of Cross-Border Bean (*Phaseolus Vulgaris L.*) Marketing in East Africa: The Case of Western Kenya and Eastern Uganda

L.W. Mauyo^{1*}, J.R. Okalebo³, R.A. Kirkby⁴, R. Buruchara⁴, M. Ugen⁵, & H.K. Maritim²

¹Kenya Agricultural Productivity Project (KAPP), District Service Unit, P.O. Box 4500, Eldoret, Kenya; ²School of Business and Management, Moi University, P.O. Box 3900, Eldoret, Kenya; ³Department of Soil Science, Moi University, P.O. Box 1125, Eldoret, Kenya; ⁴CIAT-AFRICA, P.O. Box 6247, Kampala, Uganda; ⁵Namulonge Agricultural and Animal Production Research Institute (NAARI), P.O. Box 7084, Kampala, Uganda; *Corresponding author

Abstract

Common bean is an important legume crop in East and Central Africa, providing protein, calories and cash income for rural households. Smallholder farmers in Kenya and Uganda have adopted improved bean varieties. However, the demand for common bean in Kenyan market far outstrips local supply and the country is a net importer from Uganda and Tanzania. In the recent years Kenya's bean production has been declining mainly due to bad weather conditions, soil fertility decline, pests and diseases and poor pricing policies. An efficient bean marketing system enhances food security. The objectives of this study were to investigate the price variations between rural markets and urban markets in relation to marketing costs and assess the regional market integration in the bean marketing system. It was hypothesized that price differences between any pair of trading markets are explained by transfer costs. Purposive, multistage and systematic random sampling methods were used to select the study districts, bean farmers and bean traders respectively. Two hundred and ten respondents were interviewed using structured questionnaires. Descriptive statistics were used to analyse the data. The Statistical Package for Social Scientists (SPSS) was used to generate the Pearson's bivariate Correlation coefficients. The study revealed high price differentials between rural and urban markets which were more than accounted for by transfer costs. The results further revealed that there is inefficient pricing mechanism among spatially separated markets in the study area. Correlation coefficients analysis of wholesale bean prices revealed that regional bean markets in the study area are integrated

Key words: Bean, bean prices, cross-border marketing, market integration

Introduction

In Kenya, common bean is the most important pulse and second to maize as food crop (GOK, 1998). The national annual demand for common bean has been estimated at 500,000 metric tonnes, but the actual annual production is only about 125,000 metric tonnes

(Muasya, 2001). The total area under bean cultivation in Kenya is estimated to be 500,000 ha (GOK, 1998) leading to actual bean yield of 250 kg ha⁻¹ partly under mixed cropping. In pure stands, yields of 700 kg ha⁻¹ have been reported (Muasya, 2001). This yield is low compared to a potential yield of up to 5000 kg ha⁻¹. Such high yields have already been achieved in other

countries, such as Mexico under field conditions (Muasya, 2001).

Bean consumption in Eastern and Southern Africa exceeds 50 kilograms per person per year, reaching 66 kilograms per person in parts of Kisii district of Kenya (Wortmann, 1998). Bean also contributes 30% of the dietary energy in the widespread maize-based cropping systems of mild-altitude areas of Eastern and Southern Africa (Wandel and Holmboe-Ottesen, 1992). In Uganda, bean is a major source of food security, readily available and popular food to both the urban and rural population. The crop is also an important source of income due to the increasing demands both in the domestic and export markets (NARO, 2000). In 1987, Food and Agriculture Organization, (FAO) estimated Uganda's bean consumption at 29.3 kg per capita (Kirkby, 1987). However, recent studies show that the per capita consumption in Uganda's Nabongo area is 58kg (David, 1999). In Burundi bean consumption is considered one of the highest in the world at 65kg of dry beans per inhabitant per year providing the main source of protein (Baert, 1989). Beans provide about 25% of the total calories and 45% of the protein intake of the diet of many Ugandans.

A lot of research has been done on bean improvement in East and Central Africa through breeding for pest and disease resistance, high yields and for adaptation to a wide range of environmental conditions. It is also known that smallholder farmers have adopted some of the released varieties from research institutions. However, the demand for common bean in Kenyan market far outstrips local supply and the country is a net importer from Uganda and Tanzania (ECABREN, 2000). In the recent years Kenya's bean production has been declining mainly due to bad weather conditions and poor pricing policies. An efficient marketing system is an important means of raising the incomes for farmers. This enables them to allocate productive resources according to their comparative advantages and invest in modern inputs to enhance their productivity.

This study was conducted to assess the status of cross-border bean marketing patterns in the border districts of Western Kenya and Eastern Uganda, with a view to having an efficient marketing system in the region. The objectives of the study were to investigate the price variations between rural markets and urban markets in relation to marketing costs and assess the regional bean market integration in the study area.

Methodology

The study area

This study was conducted in Bungoma and Busia districts of western Kenya and Mbale and Kapchorwa districts of eastern Uganda between March and June 2002. Primary and secondary data sources were utilised. The primary data were obtained in a survey from 104 bean farmers and 106 bean traders using structured questionnaires. Secondary data (monthly average wholesale Rosecoco bean prices) for 2001 and 2002 (Table 1) obtained from the National Cereals and Produce Board (NCPB) of Kenya and from Agribusiness Development Centre/Investment in Development Export Agriculture (ADC/IDEA Project) of Uganda, were used to analyse regional bean market integration, using the Pearson Bivariate correlation coefficients. The regional wholesale markets considered were Jinja, Mbale, Tororo (Uganda), Busia, Kamurai, Kanduyi, Chwele and Kitale (Kenya). Purposive sampling method was used to select the study districts. Systematic random sampling procedure was used to select the bean traders in selected rural markets and urban markets in the study area. Retail traders and wholesalers were identified using the volume of beans they handle. In every market the first respondent was picked arbitrarily and the next respondent was picked by skipping one. Descriptive statistics were used to analyse the data using Statistical Package for Social Scientists (SPSS) and Microsoft Excel computer programs.

Price spread

The factors that help to explain price differences associated with the provision of marketing services are discussed in this section. Price differences between those paid to the farmer and those paid by the consumer are known as marketing margins or price spread. A Marketing Margin or Price Spread is a commonly used measure of system performance (Pucell, 1979). Spatial market relationships can be described by prices, trade volume or both. Price differentials less than transfer cost are defined as "integration" even when there is no flow of product and no transmission of price shocks between the two markets (Barret and Li, 2002). If markets are integrated, the price differential or spread between markets cannot exceed transfer costs (Baulch, 1997). Barret (1996) gives taxonomy of methods based

Table 1. Monthly Rosecoco bean prices per 90 Kg bag for Kenya and Uganda

2001	Jinja	Mbale	Tororo	Busia	Kamurai	Kanduyi	Chwele	Kitale
January	1936	2145.25	2019.75	2057.50	2240	2300	2300	3000
February	2271	2417.50	2459.50	2237.50	2280	2350	2325	3275
March	2763	2721	2553.80	2480	2480	2580	2620	3200
April	3071.75	2825.50	2700	2600	2600	2700	2800	3350
May	2197.75	2846.50	2721	2600	2600	2700	2800	3350
June	1657.80	1632.60	1758.20	2600	2600	2800	2860	3280
July	1465	1360.50	1695.25	2600	2600	2800	2650	2650
August	1674.20	1465	1498.40	2600	2600	2800	2600	1680
September	1884	1569.50	1412.75	2600	2600	2775	2575	1750
October	1308.25	1621.75	1172.25	2250	2200	2300	2100	1800
November	1147	1297.80	1256	1900	1800	1900	1700	1720
December	1412.75	1256	1256	1900	1800	1900	1700	1950
2002								
January	1517.25	1412.75	1475.75	2000	1950	2050	1800	2300
February	1800	1580.25	1737.25	2100	2100	2200	1900	2400
March	1758	1548.60	2151.60	2230	2240	2320	2220	2360
April	1256	1674	2176.75	2250	2200	2300	2200	2300
May	1640.80	1758	2302.40	2280	2280	2380	2280	2620
June	1360.5	1621.75	1329.25	1950	1960	2300	2200	2700
July	1371	1412.75	1475.75	1600	1620	2000	1800	2200
August	1448.2	1557	1674.20	1620	1640	1970	1800	1720
September	1674	1621.75	1768.50	1737.50	1742.50	1587.50	1500	1700
October	1884	1465	1674	1750	1750	1500	1500	1800

Source: (NCPB, 2001–2002; ADC/IDEA Project, 2001–2002).

on the observation that spatial market analysis fundamentally depend on three sorts of data: prices, transaction costs and trade flows. Margins or spreads can be a useful descriptive statistic if used, to show how the consumers' food shilling is divided among the participants at different levels of the marketing system.

Results and discussion

Price spread

The price of beans in the study areas varied from one outlet to another because of the differences in handling services provided by the various series of outlets. In rural areas of Uganda, the average price of beans per 2kg Kimbo tin was Ksh 32.55 while in urban markets it was selling at Ksh 55.80 per 2kg Cowboy tin. In Kenya a 2kg Kimbo tin was going at Ksh 50.00 in rural areas while in urban areas it was going at Ksh 60.00 per 2kg Cowboy tin. Table 2 presents summarized results of bean price spread with transfer costs in the study area.

The gross farm-retail marketing margins (spreads) for various markets in both Uganda and Kenya are

shown in Table 3. Detailed analysis of Table 3 revealed price differentials ranging between 33.3% for Kapchorwa and Sironko markets and 53.3% for Nyalit market in Uganda while for Kenya the price differentials ranged between 16.7% for Kocholia market and 33.3% for Angurai and Malakisi markets. These figures support the argument that the buyers dictate the prices for the farmer's produce. The price of beans varies from one outlet to another mainly because of the difference in handling services provided by the various series of outlets.

Analysis of fig 1(a) & 1(b) shows that the transfer costs do not approximate the price difference between rural markets and urban markets in both Uganda and Kenya. Traders made margins far in excess of the transfer costs, which show that marketing margins were more than accounted for by the transfer costs. This could be due to poor market information and hidden costs. Marketing margin analysis indicated that a high proportion of the consumer's shilling is accounted for by profits accruing to traders particularly wholesalers. Furthermore, the high marketing margins are not compensated for by efficient distribution, proper presentation and methods of handling and hygiene standards in bean markets. The producers' low share

Table 2. Bean price spread (Ksh/100kg bag)

Country	Market	Farm gate Price (Ksh)	Transport Cost (Ksh)	Market Dues (Ksh)	Handling Cost (Ksh)	Traders' Margin (Ksh)	Consumer Retail Price - Mbale
Uganda	Bukwa	1395	140	23	65	1167	2790
	Nyalit	1302	116	23	65	1284	2790
	Mutyoru	1628	93	23	65	981	2790
	Kapchorwa	1861	93	23	42	772	2790
	Bulegeni	1628	93	23	42	1005	2790
	Muyembe	1395	70	23	42	1261	2790
	Buyaga	1628	47	23	42	1028	2790
	Sironko	1867	70	23	42	819	2790
Kenya		Ksh	Ksh	Ksh	Ksh	Ksh	Ksh
	Angurai	2,000	180	40	175	605	3,000
	Kocholia	2,500	100	40	170	190	3,000
	Malaba	2,500	80	40	145	235	3,000
	Adungosi	2,500	70	40	95	295	3,000
	Malakisi	2,000	130	40	145	685	3,000
	Chwele	2,200	80	40	165	515	3,000
	Mayanja	2,300	60	40	165	435	3,000
	Kanduyi	2,500	30	40	145	285	3,000

Source: Author's Compilation, 2002. NB: Ksh 1.00 = Ush 21.5 (March 2002, US\$ 1 = Ksh 80 (Ush 1730)).

Table 3. Bean Selling Prices (Ksh/100Kg bag) and margins

Ugandan Markets	Farm (pf) Ksh	W/sale (pw) Ksh	Retail (pr) Ksh	Farm-Retail Spread (pr-pf) Ksh	Farmer's Share (%)	W/sale/Retail Spread (pr-pw)	W/saler's Share (%)
Bukwa	1395	2090	2790	1395	50.0	700	75.0
Nyalit	1300	1860	2790	1490	46.7	460	66.7
Mutyoru	1630	2330	2790	1160	58.3	460	83.3
Kapchorwa	1860	2330	2790	930	66.7	460	83.3
Bulegeni	1630	2330	2790	1160	58.3	930	83.3
Muyembe	1395	2090	2790	1395	50.0	460	75.0
Buyaga	1630	2330	2790	1160	58.3	700	83.3
Sironko	1860	2330	2790	930	66.7	460	83.3
Kenyan Markets	(Ksh)	(Ksh)	(Ksh)	(Ksh)	(Ksh)	(Ksh)	(Ksh)
Angurai	2000	2500	3000	1000	66.7	500	83.3
Kocholia	2500	2700	3000	500	83.3	300	90.0
Malaba	2500	2700	3000	500	83.3	300	90.0
Adungosi	2500	2700	3000	500	83.3	300	90.0
Malakisi	2000	2500	3000	1000	66.7	500	83.3
Chwele	2200	2600	3000	800	73.3	400	86.7
Mayanja	2300	2700	3000	700	76.7	300	90.0
Kanduyi	2500	2700	3000	500	83.3	300	90.0

Source: Computation from Table 1. NB: Ksh 1.00 = Ush 21.5 (March 2002). US\$ 1 = Ksh 80 (Ush 1730).

of the retail price could be aggravated by the problem of instability of bean prices at the farm level as compared to the retail level. The direct delivery of beans to retailers' premises coupled with low bargaining power raises the farmer's vulnerability to low prices in the exchange exercises. Possible reason that can be

attributed to the high bean prices in the urban markets is high demand due to scarcity of the product and hidden transaction costs. Hence, it can be concluded that the retail markets are not well integrated due to high price differentials that are more than transfer costs.

Handling costs

Packaging materials, the labour employed to load and unload the produce, weighing and product preparation (sorting and grading) activities made the large share of the traders' handling costs. High expenditures on loading and offloading labour were observed in both primary and terminal markets in both Kenya and Uganda. This was due to the fact that most traders especially retailers move their produce for short distances using bicycles, donkeys and pick-ups, therefore, require loading and offloading labour every time they move their stock. The major cause of high labour charges emerged to be lack of storage and handling facilities at the selling points. In rural production areas transactions are done in open-air markets without storage facilities. Traders

with large stocks incur extra expenditures in the transfer of their carry-over stocks to their stores and back to the market everyday.

Rental stores are inadequate and also loading services include in-store packing of supplies. There is therefore, scope to reduce this cost item in order to improve the traders handling efficiency. The construction of cheap storage facilities in the markets where traders operate would not only reduce handling cost but also other costs where market traders use a lot of the capital resources (private store hiring, losses arising from carry-over stocks on transit and losses due to weather). In turn the local/county/municipal councils could generate extra revenue through stall/store hiring charges.

Government levies (market dues)

Government levies exist in form of taxes that the traders pay as market dues and trading license. On average, primary market traders incurred more expenses in government levies in both Kenya and Uganda than the terminal traders in form of trade license. The source of these disparities can be traced to different methods, which the government agencies in different areas use to collect these revenues. In the rural areas of Uganda, primary market traders were paying market fees based on the quantities offered for sale at the market. Urban market traders in those districts were however, paying a daily uniform fixed market fee that is not based on quantity of the sales stock. Similar fees are applied to their Kenyan counterparts. The applied fixed charges were particularly undesirable to the market traders as they have the effect of raising their unit costs.

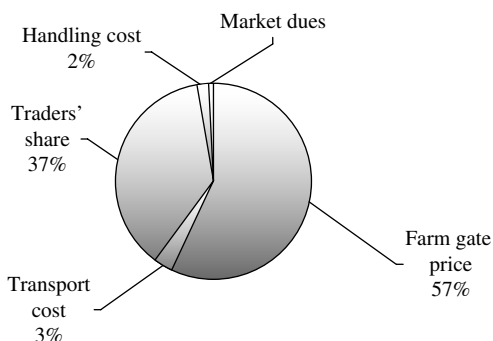

Figure 1(a). The proportion of the consumer shilling accounted for by the market participants at different stages of the marketing system in Uganda.

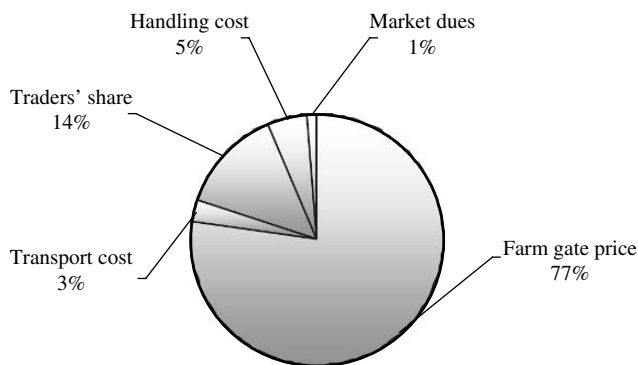

Figure 1(b). The proportion of the consumer shilling accounted for by the market participants at different stages of the marketing system in Kenya.

Bean transportation costs

Transport is the connecting link between the rural producers and the urban consumers. The modes of transport used by farmers, wholesalers and retailers included head portering, bicycles, wheelbarrows, donkeys/oxen (owned and hired), pick-ups, taxis and lorries (all hired). Farmers located in less accessible areas face a situation where large volumes of beans could hardly be marketed. Most of the areas producing beans in significant quantities were not along main roads. In both Kenya and Uganda, the cost of transport was the largest cost item of all the transfer costs when compared with the cost of packaging materials, loading and offloading, weighing, sorting and grading activities individually. The high expenditures on transport observed in both primary and terminal markets of the two countries are a reflection of the poor road infrastructure that exists and the modes of transport used. The transport charges were mainly based on distance traveled and the mode of transport used. Transport bottlenecks in form of poor road conditions create post-harvest losses reaching up to 25% of total production in Kenya (Odongo, 1999). Interviews with traders in the study area revealed that transport problems are experienced especially during rainy seasons due to poor road conditions. Gains can be derived from an efficient transport system in form of reduced transportation costs and or marketing margins. Observation of the high transport charges also revealed that on average, both farmers and traders spent more money to move beans within the primary and secondary

markets due to poor maintenance of the rural access roads and lack of effective competition amongst the primary market transporters.

Market integration

The coefficients (results) of correlation analysis are presented in Table 4.

Sixteen correlation coefficients are significant at 0.01 level. This indicates that these regional markets in the study area are highly integrated. The highest level of integration exists between Busia and Kamurai markets with a correlation coefficient of 0.988 at 0.01 ($P < 0.01$). Nine correlation coefficients are significant at 0.05 level while three correlation coefficients are not significant at both levels. These results corroborate very well with the real situation in those markets, because the beans were observed to be moving from Ugandan markets, (Jinja, Mbale and Tororo) to Kenyan markets. The common bean flow was observed to move from Jinja to Mbale into Kenya through Malaba border point and Lwakhakha border point to Chwele to Kitale markets. The bean flow was also established to move from Jinja to Tororo then to Kenya through Busia border point to Kanduyi to Chwele to Kitale markets. Another flow was from Jinja to Tororo to Kenya through Malaba border point to Kamurai to Kanduyi to Chwele. The reverse flow was also common for Kenyan markets while no flow was observed from Kenya to Uganda. Some beans were also

Table 4. Bivariate correlation coefficients Matrix

Mkts	Jinja	Mbale	Tororo	Busia	Kamurai	Kanduyi	Chwele
Mbale	0.859** 0.000						
Tororo	0.764** 0.000	0.856** 0.000					
Busia	0.465* 0.029	0.455* 0.033	0.432* 0.045				
Kamurai	0.512* 0.015	0.505* 0.017	0.480* 0.0224	0.988** 0.000			
Kanduyi	0.371 0.089	0.415 0.055	0.357 0.103	0.921** 0.000	0.933** 0.000		
Chwele	0.518* 0.014	0.582** 0.004	0.523* 0.012	0.920** 0.000	0.945** 0.000	0.967** 0.000	
Kitale	0.633** 0.002	0.766** 0.000	0.744** 0.000	0.502* 0.017	0.557** 0.007	0.541** 0.009	0.672** 0.001

** Correlation is significant at the 0.01 level (2-tailed); * Correlation is significant at the 0.05 level (2-tailed).

Source: Computation from Rosecoco bean wholesale monthly prices (Table 1).

observed to move from Kapchorwa district in Uganda to Kenya through Suam border point to Kitale. The study further established a strong integration between Kitale and Ugandan markets, with the highest integration existing between Kitale and Mbale markets with a correlation coefficient of 0.766 at 0.01 level of significance. Movement of beans from Mbale to Kitale through Lwakhakha border point creates this integration. The above results suggest that regional markets are integrated.

Conclusion

Traders made profits far in excess of the transfer costs, as their marketing margins were more than accounted for. Transfer costs did not approximate the price difference between rural markets and urban markets in both Uganda and Kenya. High price differentials between markets were observed, which were more than accounted for by transfer costs, attributed to structure and conduct of the system participants and poor transport network. There is also an inefficient pricing mechanism among spatially separated markets in the study area. However, correlation coefficients analysis of wholesale bean prices revealed that regional bean markets in the study area are integrated.

Recommendations

The following recommendations are suggested based on the findings of this study: (i) There is need to provide the necessary road infrastructure in the bean production districts of the two countries including the maintenance of all weather roads to border exit points. This will improve the transport efficiency by providing effective competition and all farmers and traders from an efficient rural transport system will derive gains in reduced transport costs, and, (ii) The two governments (Uganda and Kenya) through the local governments' authorities should construct cheap market storage facilities which are appropriately located within the open air markets in order to reduce the trader's handling and other marketing costs. This will also generate extra revenues in form of stall hiring charges.

Acknowledgements

The authors gratefully acknowledge the financial support of ECABREN/CIAT who made this study possible.

References

- ADC/IDEA 2002. *Monthly Bean Prices 2001-2002*. ADC, Kampala, Uganda.
- Baert T.G. 1989. *Bean Varietal Improvement in Africa*: In: Smithson, J.B. (Ed.) Country Report-Great Lakes: Burundi, Maseru, Lesotho 30th Jan-2nd Feb 1989; CIAT, African Workshop Series, 4: 137.
- Barret C.B. 1996. Market Analysis Methods. Are Our Enriched Toolkits Well Suited to Enlivened Markets?. *American Journal of Agricultural Economics* 78:825-829.
- Barret C.B. and Li J.R. 2002. Distinguishing Between Equilibrium and Integration in Spatial Price Analysis. *American Journal of Agricultural Economics* 84(2): 292-294.
- Baulch, B. 1997. Transfer Costs, Spatial Arbitrage, and Testing for Food Market Integration. *American Journal of Agricultural Economics* 33(4): 512-516.
- David S. 1999. *Beans in the Farming System and Domestic Economy of Uganda. A Tale of Two Parishes*. Network on Bean Research in Africa. Occasional Publications Series. No. 28. CIAT, Kampala, Uganda.
- ECABREN 2000. *Towards the development of Market-driven Research Framework. May 2000*, ECABREN, Arusha, Tanzania.
- GOK 1998. *Economic Survey*. Central Bureau of Statistics, Ministry of Finance and Planning, Government Printers, Nairobi, Kenya.
- Kirkby R.A. 1987. *Bean Research in Eastern Africa, Mukono, Uganda, 22nd-25th June 1987*. CIAT, African Workshop Series No. 2.
- Muasya, R.M. (2001). *Crop Physiological analysis of seed quality variation in common beans (Phaseolus vulgaris L.)*. Ph.D. Thesis, Wageningen University. The Netherlands.
- NARO 2000. *Annual Report*. NARO, Entebbe, Uganda.
- NCPB 2002. *Monthly Bean Prices, 2001-2002*. NCPB, Nairobi, Kenya.
- Odongo G.M. 1999. *The structure and performance of the raw Groundnut Marketing System in Kenya: The case study of Homa Bay and Migori Districts*. M.Phil. Thesis, Moi University.
- Purcell W. D. 1979. *Agricultural Marketing. Systems, Co-ordination, Cash and Futures Prices*. Reston Publishing Company Inc. Virginia.
- Wandel M. and Holmboe-Ottesen G. 1992. *Food availability and nutrition in seasonal perspective: A study from Region in Tanzania*. HUM Ecol. 20: 89-107.
- Wortmann C.S, Kirkby R.A., Eledu C.K.A. and Allen D.J. 1998. *Atlas of Common Bean (Phaseolus vulgaris L.) Production in Africa*. CIAT, Cali, Colombia (Publication No. 297).

Assessment of farmers' perceptions of soil quality indicators within smallholder farms in the central highlands of Kenya

Mairura F.S.¹, Mugendi D.N.¹, Mwanje J.I.¹, Ramisch J.J.² and Mbugua P.K.³

¹Department of Environmental Resource Conservation, Kenyatta University, P.O. Box 43844, Nairobi, Kenya;

²Tropical Soil Biology and Fertility, P.O. Box 30677, Nairobi, Kenya; ³Department of Botany, Kenyatta University, P.O. Box 43844, Nairobi; Author email for correspondence (fsmairura@yahoo.com)

Abstract

A study was conducted to determine farmers' perceptions of soil quality and soil management practices that influenced soil fertility within farmers' fields in Chuka and Gachoka divisions in central Kenya highlands. Soils were characterized by farmers after which they were geo-referenced and sampled at surface depth (0–20 cm) for subsequent physical and chemical analyses, to determine differences within farmers' soil quality categories. Special attention was given to agricultural weed species. Indicators for distinguishing productive and non-productive fields included crop yield, crop performance, soil colour and soil texture. A total of 18 weed species were used to distinguish between high and low soil categories. Significant differences among soil fertility categories implied that there were qualitative difference in the soils that were characterised as different by farmers. Fertile soils had significantly higher pH, total organic carbon and exchangeable cations, with available-N being significantly different in Gachoka. Factor analysis on 15 soil properties identified 4 factors that explained 65% of the total variance in soil quality. Soil fertility and crop management practices that were investigated indicated that farmers understood and consequently utilized spatial heterogeneity and temporal variability in soil quality status within their farms as a resource to maintain or enhance agricultural productivity

Key words: Farmers, Indicator weed species, Local indicators, Scientists, Soil fertility, Factor analysis

Introduction

Scientists and farmers are becoming increasingly concerned about the declining fertility of soils in the highlands of Eastern Africa and Sub-Saharan Africa (Sanchez and Leakey, 1997). Due to continuous intensive cropping, farmers have experienced declining crop yield over time (Mugendi et al., 1999), hence raising both scientific, and farmer environmental concerns over soil quality. Soil fertility declines at a rate that is largely governed by the type of land use systems introduced and their management (Zitong et al., 2003). Additionally many factors including soil management regimes within regions and farmers' fields contributes to soil variability, such that there are highly degraded soils within small landholdings in Africa.

Intensively managed landholdings in central Kenya typically contain three enterprise areas; namely, the

'outfields' mainly constitute cereal-legume intercrops intended for home consumption, 'infields' of market crops, and 'home sites' where livestock is confined and manures and composts are accumulated and kitchen gardens cultivated (Woomer et al., 1998). Crop residues from the 'outfields' are typically harvested and fed to livestock while manures are applied to valued crops, especially those of the 'infields' intended for market. The consistent nutrient 'mining' of 'outfields' results in nutrient deficient soils and crops that are characteristic of most small-scale farms (Murage et al., 2000). The spatial variability in soil fertility resulting from farm-level decisions about soil management is characterisable by indicators utilised by farmers and scientists. In Kenya, local soil indicators have not been fully evaluated in most smallholder farming systems, yet a scientific assessment of farmers' soil knowledge is needed to result in better soil

management by scientists and farmers. Until recently, scientists underestimated farmers' knowledge on soil fertility and management (Richards, 1985; Fairhead, 1992; Nandwa and Bekunda, 1998). Because of its' importance, a quantitative assessment of soil quality is needed to determine the sustainability of land management systems as related to agricultural production practices, and to assist farmers and scientists in formulating and evaluating agricultural land use systems. However soil quality cannot be measured directly, but must be inferred from soil quality indicators and visual farmers' and scientists' assessments. Many soil properties are correlated (Larson and Pierce, 1991), and must therefore be evaluated by statistical procedures that account for multivariate correlation among soil attributes. This study aims at evaluating soil quality indicators and variability by relating soil analysis and farmer soil quality perceptions within village enclaves that were sampled in Central Kenya Highlands, which are characterised by intensive soil management. The study was therefore undertaken, to identify indicators of soil quality status that were consistent with farmers' perceptions of soil quality. Assessment of soil quality is invaluable in determining the sustainability of Kenyas' agricultural practices. A comprehensive assessment of how farming communities recognize and measure soil quality is needed so that indigenous knowledge can be integrated with scientific knowledge to contribute to soil quality information (Doran and Parkin, 1994). As specific concepts, 'soil fertility' and 'soil quality' are used in congruity and in similar manner with Patzel et al. (2000). The objective of the study was to determine indicators of soil quality status that are consistent with farmers' perceptions of soil quality in Chuka and Gachoka divisions, in central Kenya. The fields that were studied were characterised by farmers into high and low fertility farm areas based on farmers experiences and indicators. The study aimed to find out if the farms identified as of high fertility had better soil properties compared to poor fields, based on means and multivariate evaluation of soil indicators.

Materials and methods

Site description

The study was conducted in two agricultural districts of central Kenya highlands, located approximately 150 km NE of Nairobi. Sixty farms were

sampled in village enclaves of Kirege and Gachoka sub-locations in Chuka and Gachoka divisions respectively. Chuka division lies in the Upper Midland zone 2 and 3 (UM2–UM3) at an altitude of 1500 m, with an annual rainfall ranging from 1200–1400 mm (Jaetzold and Schmidt, 1983). Soil type is mainly Humic Nitisol with those in Gachoka being dominated by the Nito-rhodic Ferralsols (Jaetzold and Schmidt, 1983). The area is dominated by slope cultivation (up to 60%) and crop-livestock enterprises that are intensively managed (Warner, 1993; Lekasi et al., 2001). Gachoka division lies at the transition between the marginal cotton (LM 4) and main cotton (LM3) agro-ecological zones (Jaetzold and Schmidt, 1983) with a mean annual rainfall of 900 mm (Government of Kenya, 1997). Rainfall distribution pattern is bimodal, in both divisions with the short rain (SR) and long rain (LR) season falling annually from March to June and October to December, respectively (Jaetzold and Schmidt, 1983).

Household interviews and field observations

The study was conducted within the months of February and October in 2003. First, field instruments were pretested during the dry season in the month of February while the main study was conducted during the rainy season in the months of March to June. Farmers were asked to identify plots that they either regarded as productive (good quality) or non-productive (poor quality). Soil fertility indicators (weed species and descriptive indicators) with high and low productive soils were also recorded. Agricultural weeds that represented high and low fertility fields were recorded and sampled. The weeds specimen were collected, pressed, and identified at the Botany Department herbarium in Kenyatta University.

Soil sampling and analysis

Farmers were asked to characterise fields into high and low fertility farm sector units (Gachimbi et al., 2002), and these were later paired (Wardle, 1994). Soils were sampled in the long rain season. After geo-referencing (Tenywa et al., 1999), ten topsoil (0–20 cm) samples were collected from the top soil and composited. Sub-samples (500g) were sealed and transported in cool boxes for laboratory analyses (Anderson and Ingram, 1993). Soils were analysed for texture, pH, calcium,

magnesium, available nitrogen, soil organic carbon, total nitrogen, and phosphorous.

Soil texture was determined using the Bouyoucos Hydrometer method. Soil pH was determined by water extraction in a 1:2.5 ratio. Exchangeable bases (Ca and Mg) were extracted in 1M KCl, followed by colorimetric and titrimetric determination respectively. For available P extraction, a 0.5M NaHCO₃ + 0.001M EDTA, pH 8.5 solution was used, followed by colorimetric determination. Ammonium-N was determined by the salicylate-hypochlorite colorimetric method, while Nitrate-N was determined by the cadmium-reduction method. Total organic carbon was determined through colorimetric determination of chromic (Cr³) after soils were digested in acidified dichromate at 130°C for 30 minutes. Total N and P were determined using the Kjeldhal Digestion method (Anderson and Ingram, 1993).

Data analysis

Social data was entered and analysed in SPSS version 11 (SPSS, 2002), while soil measurements were entered in Genstat. Soil parameters were compared by ANOVA in Genstat 5 Release 3 (Genstat, 1995), whereby the soil quality categories were the grouping variables (Wardle, 1994). Means for soil properties were separated using LSD stepwise separation. Factor analysis was used to study the relationship among soil variables, by statistically grouping 15 soil attributes into 4 factors (Brejda et al., 2000). Varimax rotation with Kaiser normalisation was used because it results in a factor pattern that loads highly into one factor, which was considered to offer a theoretically plausible and acceptable interpretation of the resulting factors.

Results and discussion

Indigenous knowledge and soil quality assessment

Descriptive soil indicators

The most important indicators included crop yield and crop performance that were utilised by more than 60% of the farmers in both divisions (Table 1). Other indicators included soil colour, soil texture, and agricultural weed species (Table 2). Usually, fields were characterised as either fertile or infertile, with indicators described dichotomously as either good or bad, or high or low. The most common indicators included crop yield, which was identified by 86% of the farmers in Chuka Division, as compared to 67% in Gachoka division. Other indicators in Chuka were crop performance (77%), soil colour (60%). The least common indicators were soil texture, fertiliser response, and soil moisture retention which were identified by less than 40% of the farmers. Table 1 shows the soil quality indicators utilized by farmers in both divisions.

Farmers used characteristics that they could see, feel, or smell in their fields, based on historic experiences in cultivating their fields and readily recognised that soil quality affected crop performance and yield. Crop characteristics are easily assessed by farmers, and their evaluation by scientists find them highly responsive to soil fertility. Despite descriptive soil indicators, farmers identified agricultural weed species that were found to be crucial visual criteria. Scientists have advocated that local knowledge is useful to determine soils' relative productivity, which is increasingly viewed as an important component for better soil management (Pawluk et al., 1992). The dominance of soil texture and soil colour as a differentiating characteristic (Table 1) is common in farmer soil knowledge, which has been shown to tally formal soil classifications in ethnopedological studies (Talawar and Rhoades, 1997).

Table 1. Descriptive indicators used by farmers to distinguish soil quality status within fields in Chuka and Gachoka divisions, Kenya

Chuka Division		Gachoka Division		P-value
Indicator	% farmers	Indicator	% farmers	
Crop yield	86 (26)	Crop yield	67 (20)	0.000
Crop performance	77 (23)	Crop performance	63 (19)	0.000
Soil colour (wet)	60 (18)	Soil colour (wet)	83 (25)	0.003
Soil macro-fauna	50 (15)	Soil macro-fauna	37 (11)	0.000
Soil tilth	40 (12)	Soil tilth	40 (12)	0.027
Soil texture	40 (12)	Soil texture	43 (13)	0.000
Fertiliser response	13 (4)	Fertiliser response	20 (6)	0.000
Soil moisture retention	3 (1)	Soil moisture retention	7 (2)	0.000

Agricultural weed species

On further probing, farmers identified agricultural indicator species. The high and low fertility indicator species are shown in Table 2. The most frequent high fertility indicator species (*Commelina benghalensis* L.) was recorded on 77% of fields in Chuka division while in Gachoka division it was Black jack (*Bidens pilosa* L.) found in 67% of the farms (Table 2). Additionally, the most frequent low fertility indicator weed species in Chuka division (*Melhanian ovata* (Cav.) Spreng) was recorded on 67% of the fields, with a higher frequency for Gachoka division (93%) (Table 2).

Other indicators that were recorded on productive fields included the gallant soldier (*Galinsoga parviflora* L.) and *Amaranthus spp* which were recorded in 20% of the fields in Chuka division and 29% in Gachoka division (Table 2). Additionally, low fertility species included the goat weed (*Ageratum conyzoides* L.) which occurred on 37% and 10% of the fields in Chuka and Gachoka respectively (Table 2). The red top grass (*Rhynchelytrum repens* (Willd., C. E. Hubbard) was more frequent in Gachoka (70% as compared to Chuka (27%) cited by farmers as a low fertility

indicator (Table 2). In both divisions farmers admitted that there was a high diversity of species on productive soils as compared to poor soils.

Species composition from Commelinaceae and compositae weed families were frequent as high fertility indicators in upto 50% of the fields in both divisions (Table 2). The Wandering Jew (*Commelina benghalensis* L.) and gallant soldier (*Galinsoga parviflora* L.) were found to be frequent in high fertility fields as was reported in central Kenya by Murage et al. (2000). Low soil fertility indicators included the red top grass (*Rhynchelytrum repens* (Willd.) C. E. Hubb). Several other studies that have been conducted in the region have found agricultural weeds similar to those found in this study. Globally, smallscale farmers have been reported to associate the nature and condition of vegetation, both native and planted with level of field soil fertility (Shaxson, 1997). However much of this knowledge is resident only in the minds of observant farmers and consequently needs to be further developed through balanced research designs. In Latin America, Suarez et al. (2001) found agricultural weeds to indicate the level of agricultural disturbance on soil productivity.

Table 2. Indicator weed species of high and low soil fertility status in Chuka and Gachoka divisions, Kenya

High fertility indicator species				
Indicator species			Percentage frequency	
Scientific name	Common name	Botanical family	Chuka	Gachoka
<i>Commelina benghalensis</i> L.	Wandering jew	Commelinaceae	77 (23)	53 (16)
<i>Galinsoga parviflora</i> L.	Gallant soldier	Compositae	63 (19)	17 (5)
<i>Bidens pilosa</i> L.	Black jack	Compositae	43 (13)	67 (20)
<i>Amaranthus spp</i>	Pigweed	Amaranthaceae	20 (9)	27 (8)
<i>Sonchus oleraceus</i> L.	Sow thistle	Compositae	17 (5)	13 (4)
<i>Commelina diffusa</i> Burm.f.	–	Commelinaceae	9 (30)	53 (16)
<i>Solanum nigrum</i> L.	Black nightshade	Solanaceae	7 (2)	20 (6)
<i>Rottboellia exaltata</i> (L.f)	Guinea fowl grass	Gramminae	7 (2)	7 (2)
Low fertility indicator species				
<i>Melhanian ovata</i> (Cav.) Spreng	–	Malvaceae	67 (20)	93 (28)
<i>Ageratum conyzoides</i> L.	Goat weed	Compositae	37 (11)	10 (3)
<i>Emilia discifolia</i> (Oliv) C. Jeffrey	–	Compositae	37 (11)	3 (1)
<i>Rhynchelytrum repens</i> (Wild.) C.E.Hubbard	Red-top grass	Gramminae	27 (8)	70 (21)
<i>Pteridium aquilinum</i> (L.) Kuhn	Bracken fern	Pteridophyte	27 (8)	14 (4)
<i>Tagetes minuta</i> L.	Mexican marigold	Compositae	16 (5)	23 (7)
<i>Oxygonum sinuatum</i> (Meisn.) Dammer	Double thorn	Polygonaceae	10 (3)	3 (1)
<i>Schkuhria pinnata</i> (Lam.) Thell.	Dwarf marigold	Compositae	3 (1)	10 (3)
<i>Setaria verticillata</i> (L.) Beav.	Bristly foxtail	Gramminae	–	23 (7)
<i>Cucumis</i> L.	–	Cucumbitaceae	–	20 (6)

Table 3. Ranking and scoring of indicators by farmers in Chuka and Gachoka divisions

Indicator	Total score		Meanscore		Rank	
	Chuka	Gachoka	Chuka	Gachoka	Chuka	Gachoka
Crop yield	146	129	10	9	1	1
Crop performance	114	128	8	9	2	2
Soil colour	106	100	7	7	3	3
Soil tilth	96	97	6	6	4	4
Soilfauna	85	90	4	6	5	5
Soil texture	93	81	6	5	6	6
Fertiliser response	64	77	4	5	7	7
Soil moisture retention	70	75	5	8	8	8
Indicator species	64	64	4	4	9	9

¹ Scoring of indicators (Table 5) was based on a ranking scale from 1–10, with 1 as the least important to 10 as the most important. Fifteen farmers in both divisions who were sampled for soils were involved in the ranking and scoring.

Farmer's ranking of indicators is shown in Table 3. Crop yield and crop performance were important indicators used by farmers, having been ranked number of 1 and 2 respectively in both divisions. The relative importance of the indicators was almost similar, with a fairly high rank correlation (0.62). The agricultural weed species that were used are identified at species level (Table 3).

Farmers' perceptions of soil quality

As regards soils fertility status, farmers were requested to give information on their perceptions depending on whether they felt that their fields were of high or of low productivity. The results on soil quality perceptions are presented in Figure 1. In Chuka division, 35% of the farmers admitted that the status of their fields was low,

which compared with 16% in Gachoka. Most farmers classified their fields as moderate (42% in Chuka and 64% in Gachoka). Additionally, only 14% and 9% of the farmers in Chuka admitted high and very high soil categories respectively, while there were none in Gachoka.

Farmers expressed their views that soil fertility was declining, stagnant or improving in different situations and soil erosion was regarded as a constraint to crop production. Most of the farmers in Chuka reported moderate (33%) to high levels (50%) of soil erosion, while in Gachoka low and moderate levels of soil erosion were realised. Erosion extent was determined by examining formation of rills and gulleys and by observing runoff during the wet seasons.

Contrasting responses over soil fertility changes were reported in both divisions. Most farmers reported

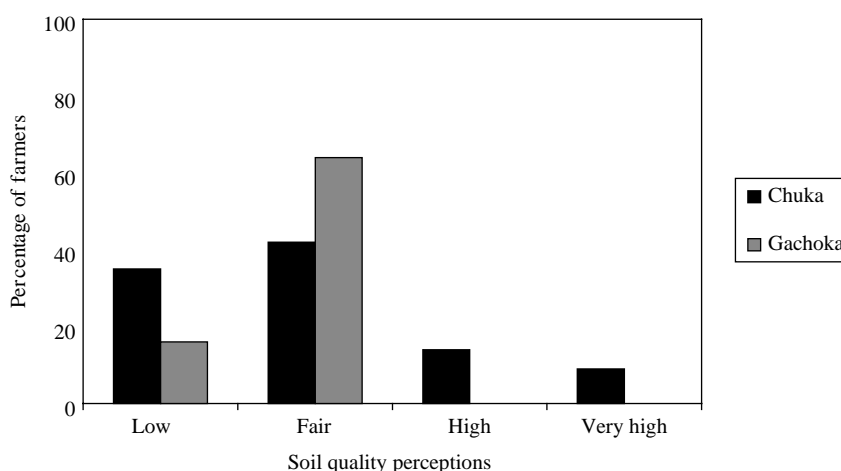

Figure 1. Perceptions of soil quality status by farmers at their fields in chuka and Gachoka divisions, Kenya.

that soil quality has been declining in both divisions, and realized that past soil management practices had influenced inherent soil fertility status. Shresta (2000) found conflicting results with soil fertility changes after interviewing different farmers who had cultivated continuously for 30 years in Asia. This was also observed by Tabor et al. (1990) in Mbeere District, Kenya, and by Shaxson (1997). This is attributed to the fact that farmers evaluate soil fertility within their own fields (Tabor et al., 1990) and rarely undertake regional assessments.

Crop distribution and soil quality management

Different crops were cultivated in productive and non-productive fields, though some were also grown on both high and low fertility soils. The major crops included maize (*Zea mays* L.) and beans (*Phaseolus vulgaris* L.) in both divisions. Farmers in Gachoka mainly grew cereals, including finger millet and sorghum (*Sorghum bicolor* L.) that were intercropped with grain legumes. Tuber crops (cassava (*Manihot esculenta* L.), sweet potatoes (*Ipomea batatas* L.) and fodder grasses mainly occurred on poor soils in both divisions. Most smallholders in Chuka (83%) and Gachoka (80%) used fertilisers, averaging 37 and 21 kg ha⁻¹yr⁻¹ respectively. The distribution of crops by soil fertility categories is shown in Table 4.

Under increasing population density and land pressure, few farmers have the opportunities to fallow their land long enough to maintain soil fertility at sustainable levels, hence continuous intensive cropping systems prevalent in central Kenya. Farmers in the region therefore use fertilisers at less than 60kg N and P, that is nationally recommended (Cheruiyot et al., 2001)

on valuable crops and preferred soils due to shortage in fertiliser inputs (Table 4). Additionally, organic resources and fertilisers are usually patchily applied within fields based on local perceptions of soil quality (J.J Ramisch, in press), and this indicated differences in soil mean properties in the high and low fertility plots that were analysed (Table 6). Routine agricultural practices, including rotation, planting, tillage and fertiliser application can create soil quality variation in the field (Gotway and Hergert, 1997). Recent research in Zimbabwe (Carter and Murwira, 1995) demonstrated how crop choice and field uses of organic and inorganic fertilizers are deliberately varied in accordance with small-scale variations in soil fertility conditions. In Zimbabwe as well as in central Kenya, farmers utilise spatial heterogeneity in soil fertility status within their fields as a means to maintain or enhance agricultural productivity.

Soil properties

Soil physical and chemical properties

In table 5 and 6, the means and SEDs of measured physical and chemical soil properties are presented, while the distribution for significant parameters is subsequently shown as box plots (Figures 2a–2f).

Clay averaged 33% and 35% for high and low fields in Chuka division, while it was approximately 31% in Gachoka on both soil categories. Additionally, sand averaged 38% in Chuka for both fields, while it was 67% and 64% for high and low fields in Gachoka. Silt was higher in the fertile fields in Chuka (29%), while poor fields had 27% silt content. In Gachoka soils, silt

Table 4. The distribution of crops on high fertile soils in Chuka and Gachoka divisions

Soil fertility categories	Crops	Divisions	
		Chuka (%)	Gachoka (%)
High fertility soils	Maize	93	50
	Beans	50	50
	Irish potatoes	50	—
	Bananas	70	—
	Sweet potatoes	88	100
	Cassavas	63	88
	Maize	13	—
Low fertility soils	Napier grass	67	77
	Sorghum	10	100
	Cowpeas	Not grown	65
	Millet	Not grown	100

Table 5. Soil physical properties on high and low fertility sites on farmers' fields in Chuka and Gachoka divisions

Site	Farmer soil category	Clay %	Sand %	Silt %
Chuka	High	32.9	37.9	29.2
	Low	34.5	38.0	27.5
	SED	3.7	3.7	5.0
Gachoka	High	30.3	67.1	2.7
	Low	32.9	64.0	3.1
	SED	5.5	3.2	5.0

Table 6. Soil chemical properties from high and low fertility sites in Chuka and Gachoka divisions

Soil Quality Category	TN	TP	C	N	P	Ca	Mg	PH
	%		Mgkg ⁻¹			cmol _c kg ⁻¹		
<i>Chuka</i>								
High	0.16a	0.05a	33.6a	2.74a	20.5a	8.2a	3.1a	5.6a
Low	0.16a	0.05a	24.3b	2.79a	16.0a	7.5a	2.8b	5.1b
SED	0.02	0.01	3.99	0.16	4.27	0.65	0.12	0.08
<i>Gachoka</i>								
High	0.16a	0.05a	15.2a	2.43a	17.8a	5.8a	1.8a	6.5a
Low	0.02a	0.05a	12.5b	1.40b	6.2a	3.8b	1.3b	6.4b
SED	0.18	0.01	0.18	0.21	7.27	0.48	0.15	0.09

¹For table 5 and 6, means followed by different letters in the same column are significantly different.

was negligible. There were no statistical differences in the soil physical means by land categories.

Mean clay and sand contents were almost similar on soil categories suggesting that the test sites were of similar pedogenic properties (Jaetzold and Schmidt, 1983), implying that the differences in chemical properties must have resulted from past soil management (Murage et al., 2000). The soils could thus be comparably evaluated (Karlen et al., 1994). Silt was slightly lower in poor sites in Chuka division, especially on sites that farmers had identified soil erosion as the main constraint to crop production. Though the difference was not significant, this is congruent with the principle that silt is usually the first mineral component of the soil to be detached in water erosion processes (Brady, 1984).

Table 6 shows means of soil chemical properties in high and low soil categories.

The boxplots (Figures 2a–2f) indicate the distribution of different soil properties within the high and low fertility sites in Chuka and Gachoka divisions.

The productive soils showed higher soil C ($p < 0.05$) (Figure 2a), and exchangeable cations than infertile soils in both divisions, averaging Fertile fields in Chuka division showed a carbon level of 33.6 mg kg⁻¹ as compared to 24 mg kg⁻¹ for poor fields (Figure 2a). In Gachoka, low fertility carbon was also significant and averaged 12.5 mg kg⁻¹ while the fertile plot mean was 15.2 mg kg⁻¹. Ca²⁺ ($p < 0.001$) (Figure 2b) was only significant in Gachoka division, while Mg²⁺ (Figure 2c) was higher ($p < 0.05$) in fertile sites in both divisions. On fertile soils, the mean calcium content was 8.2 mg kg⁻¹ as compared to 7.5 mg kg⁻¹ for poor soils in Chuka division while in Gachoka division, calcium was lower, averaging 5.8 mg kg⁻¹ and 3.8 mg kg⁻¹ on high and poor fields respectively. Soil reaction (pH) (Figure 2d) was higher in both divisions ($p < 0.001$) on soils that farmers identified as fertile. Soil pH averaged 5.6 and 5.1 in fertile and poor fields in Chuka division respectively. In Gachoka division, the fertile soils were slightly more basic than poor fields.

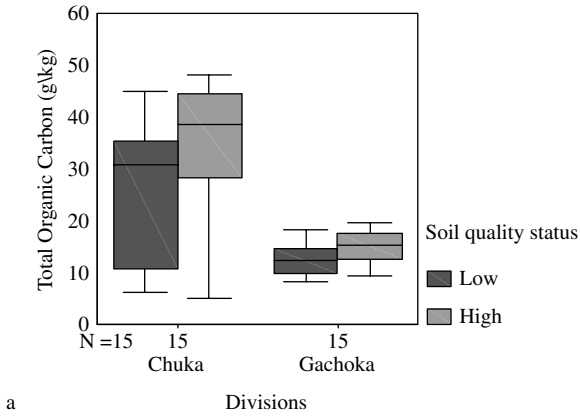

Figure 2a. Comparisons of total organic carbon.

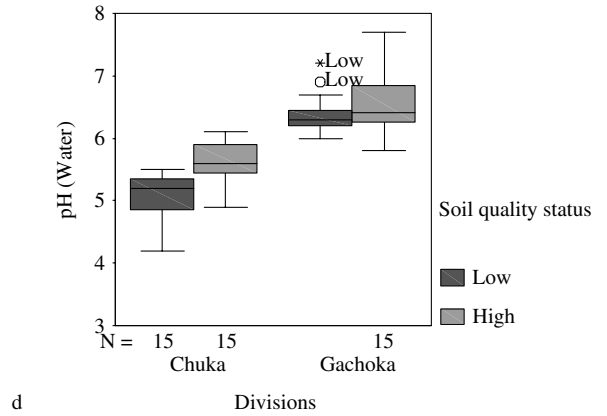

Figure 2d. Comparisons of soil reaction (pH).

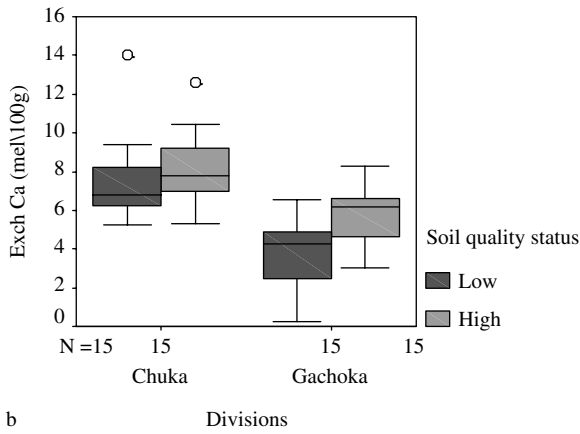

Figure 2b. Comparisons of exchangeable Ca.

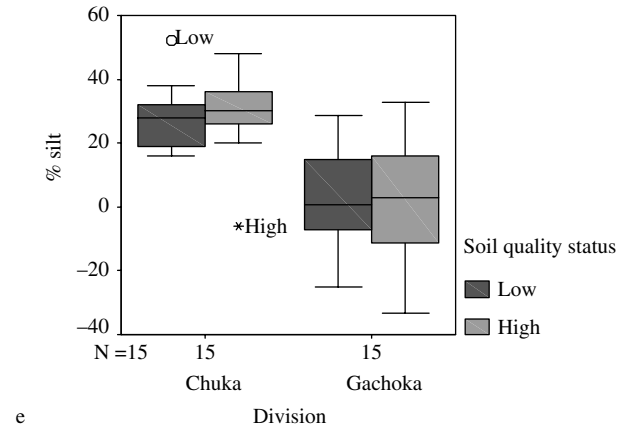

Figure 2e. Comparisons of extractable inorganic-N.

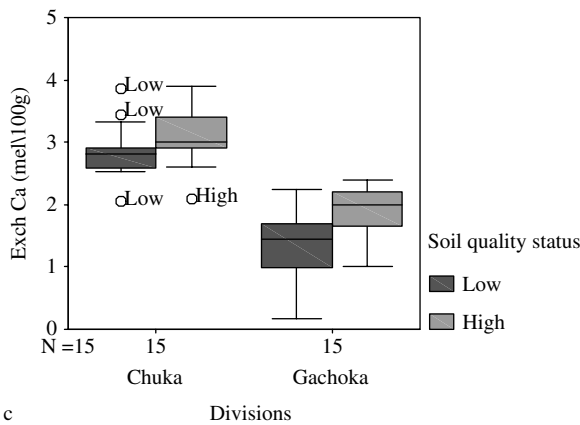

Figure 2c. Comparisons of exchangeable Mg.

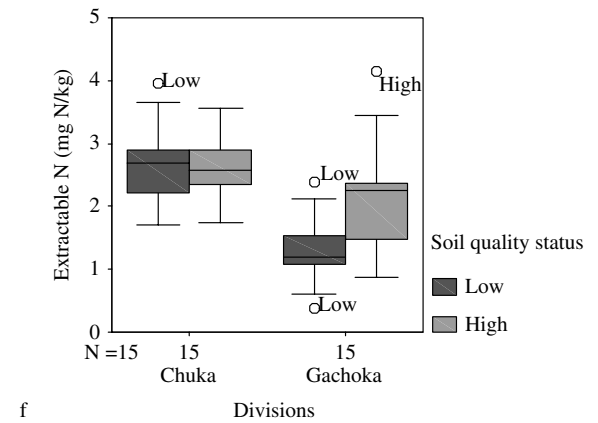

Figure 2f. Comparisons silt content.

Extractable inorganic-N (Figure 2e) was different ($p < 0.05$) in Gachoka soils while it was not different among sites in Chuka, averaging 2.8 and 2.7 mg kg⁻¹. The differences in Gachoka were 0.12 and 0.28 mg kg⁻¹ ($p < 0.005$) for low and high fertility soil categories respectively (Figure 2e).

There were no differences in total P in both divisions suggesting it was not a sensitive indicator of soil quality. Total nitrogen in Chuka division averaged 0.16% (Table 6) in both farmer soil types. In Gachoka, total nitrogen ranged widely, averaging 0.16% and 0.002% for productive and non-productive soil categories respectively.

The soil cations were low in poor soils in both divisions, as compared to the fertile soils, mainly due to higher organic matter content on fertile sites (Hoffmann et al., 2001). The fertile soils reflected a higher capacity to hold nutrients than the non-productive soils in both divisions, due to higher exchangeable cations in the soils. Because exchangeable bases and pH are mainly influenced by soil organic matter, and the clay types and quantities were similar at poor and fertile soils (Table 5), the differences in Ca, Mg and soil reaction (pH) are likely to have been caused by differences in soil organic carbon (Brady, 1984; Hoffmann et al., 2001; Gachene and Kimaru, 2003) (Table 6). For magnesium, cropping intensity affects the amounts that are available in soil. Also, poorly managed fields that were more eroded may have led to faster losses of calcium and magnesium through leaching, hence a lower value.

Liebig and Doran (1999) compared farmers' soil knowledge along established assessment protocols. Twenty-four conventional and organic farmers in eastern Nebraska, USA, were paired within regions based on similar agroclimates and soils, and their soil perceptions of conditions for 'good' and 'problem' soils on their farms were queried using a written questionnaire. Their perceptions of soil quality indicators tended to match the scientific assessment closely for 'good' soils, but less so for 'problem' soils. Indicators that were incorrectly estimated at a frequency greater than 33% included available N and P, soil colour, degree of compaction, and infiltration rate. Despite this, farmers' perceptions were consistent for upto 75% of the time for the majority of indicators evaluated in the study. Arshad and Coen (1992) also found that many soil attributes can be estimated by calibrating quantitative observations against measured values and in tandem with Kundiri et al. (1997) and Halvorson et al. (1996), recommended that qualitative

knowledge should be an integral part of soil quality information.

Available P indicated that soils in Chuka division had a higher capacity to supply P for crop growth, although this difference was not significant. However, twenty (20) of the 30 pairs within fields matched consistently the soil categories that farmers had ascribed. The higher amount of readily available P in fertile soils may partly reflect higher fertilisation as associated with preferential use of soil inputs on fertile soils and valued crops (Table 4) as compared to low quality soils (Schjonning et al., 2002). For Humic Nitisols that were cultivated in central Kenya, Murage et al. (2000) found significant differences for available P, though that was not the case in this study.

The fertile soils reflected a higher capacity to hold nutrients than the non-productive soils in both divisions, due to higher exchangeable base cations, hence reflecting better crop yields and performance as identified by farmers. In fertile soils, farmers predominantly grew valued crops intended for market and these sites were also associated with animal sheds, where soil carbon accumulated. Conversely, planting of fodder grasses and lack of soil amendment characterised the poor fields. The consistent nutrient mining from poor fields eventually leads to nutrient-deficient farm sector units. Murage et al. (2000) and Woome et al. (1998) reported on-farm nutrient mining processes resulting in highly degraded fields and farm soil fertility gradients.

Soil factor analysis and variability

Table 7 shows the factor analyses for the measured soil properties, explaining the amount of variability accounted for by various soil factors. The 15 soil attributes initially analysed were reduced by factor analysis to 4 main soil components by principle components analysis (PCA) with Varimax rotation. The first four factors explained 65% of the variance (Table 7), and had eigen values that were greater than 1 (Table 8).

The 4 reduced components (Table 8) were consequently retained for identification and interpretation (Brejda et al., 2000). Large amounts of correlations (loadings) between nutrients and factors were used to identify the factors (Brejda et al., 2000). Soil attributes that loaded values greater than ± 0.3 were used to group and identify soil factors (Brejda et al., 2000). Table 8 shows the component matrix with corresponding loadings, eigen values, and communalities for extracted factors associated with soil parameters.

Table 7. Percentage of variance explained by soil factors in Chuka and Gachoka soils

Component	% of variance	% Cumulative variance
1	32.2	32.2
2	14.4	46.6
3	13.3	59.9
4	8.6	68.5
5	6.9	75.4
6	5.3	80.7
7	4.6	85.3
8	4.2	89.5
9	3.9	93.4
10	2.7	96.1
11	1.7	97.8
12	1.5	99.3
13	0.7	100
14	0.0	100
15	0.0	100
Total	100	

The first factor had a high positive loading on exchangeable magnesium (0.844), calcium (0.736), available nitrogen (0.743) and high a negative loading on soil pH (−0.677) (Table 8). As a result, the factor was identified as the 'exchangeable bases and soil acidity factor'. The second factor had fair loadings on total nitrogen, available nitrogen and organic carbon (0.379) (Table 8), which was identified as the 'organic matter factor', because it mainly comprised of

soil organic resources. Component 3 recorded high positive loadings on extractable phosphorous (0.588) and available nitrogen (0.457). This factor was therefore identified as the 'fertility factor' (Table 8). The fourth factor mainly comprised of soil physical properties, with moderate positive loadings for macroaggregate stability (0.458), microaggregate stability (0.351), silt (0.305), and high negative loading for clay (−0.816) (Table 2). It was therefore identified as the 'soil physical factor'. The extracted factors also explained 57% of the variance in available phosphorous, carbon (58%), calcium (65%), pH (65%), clay (72%), total nitrogen (72%), silt (73%), magnesium (77%), sand (77%), total phosphorous (85%) and available nitrogen (89%), as indicated by their communalities (Table 8).

Based on the soil attributes that comprised them, all components in the four factor model (Table 8) contribute to one or more of the soil quality factors proposed by Larson and Pierce (1994). The 'exchangeable bases and soil acidity factor' contributes to the ability of the soil to supply nutrients and sustain root growth. This factor was important explaining 32% of the variance, and was frequently expressed by farmers in various crop growth characteristics as indicators of soil quality. The 'organic matter' and 'physical' factors contribute to the ability of the soil to accept, hold, and release soil water and nutrients, and to respond to management and resist degradation (Larson and Pierce, 1994). This factor explained 14% of the soil variance in soil quality.

Table 8. Rotated factor loadings, eigen values and communalities for four factor model of physical and chemical properties in Chuka and Gachoka divisions

Soil attributes	Factor				Communalities
	1	2	3	4	
Exch Mg (me/100g)	.849	−6.484×10 ^{−2}	−.200	.113	0.777
Sand %	−.770	.219	.258	.248	0.769
Nitrate (mg N/kg)	.764	.258	.459	−.147	0.883
%silt	.754	−.108	−.232	.305	0.727
Available N(mg N/kg)	.743	.346	.457	−6.651×10 ^{−2}	0.886
Exch Ca (me/100g)	.736	3.467×10 ^{−2}	−.304	.137	0.653
PH (Water)	−.677	.351	.261	1.862×10 ^{−3}	0.649
Total Organic Carbon	.557	−.344	.379	6.817×10 ^{−2}	0.577
Microaggregates	−.428	−3.730×10 ^{−2}	−8.664×10 ^{−2}	.351	0.315
% P	.129	.799	−.439	−7.116×10 ^{−2}	0.853
% N	.106	.734	−.391	−.124	0.719
Ammonium (mgN/kg)	−3.342×10 ^{−2}	.423	2.570×10 ^{−2}	.359	0.309
Olsen P (mg P/kg)	.193	.470	.558	6.814×10 ^{−3}	0.57
Clay %	−2.284×10 ^{−2}	−.198	−.134	−.816	0.723
Macroaggregates	.119	−.198	−6.450×10 ^{−2}	.458	0.267
Eigen values	4.592	2.15	1.571	1.365	

The 'fertility management' factor is important in supplying nutrients to plants especially P, and promoting root growth (Brejda et al., 2000). This factor was frequently expressed by farmers in various crop growth characteristics, explaining 13% of the soil variance, while the 'physical factor explained 8.6% of the total variance. The communalities (Table 8) for chemical properties were generally higher than for soil physical attributes implying that they were more important in identifying soil factors and explaining the variation in soil quality (Brejda et al., 2000). This implies that exchangeable cations differed most spatially among soil nutrients. Exchangeable bases vary more than other soil elements (Arnon, 1992) due to soil management, including cropping and fertiliser uses (Kanwar, 1975).

The use of fertilisers on preferred fields (high fertility sites) and crops by the farmers (Table 4) partly explains the differences in calcium. Additionally, the losses due to leaching cations are usually very high, and mainly influenced by soil texture, and management regimes including cropping and fertiliser uses as reported by Kanwar (1975). In central Kenya, characterised by intensive cultivation and competing agricultural enterprises, the use of fertilisers and carbon inputs is maximised on preferred fields (high fertility sites) and crops (Table 4). This can explain differences in calcium due to changes induced in soil organic resources management regimes.

Conclusion

To assess a general soil quality status and to evaluate the potential for sustainable crop production, reliable measurements of soil quality should distinguish between contrasting sites, and at the same time, be sensitive to changes in management practices. Soil properties were analysed to substantiate indicators that were consistent with farmers' perceptions of soil fertility as was influenced by soil management. The results indicate that there were significant differences ($p < 0.05$) among soil fertility categories for key soil properties, suggesting that there was a qualitative difference in the soils that were characterised as different by farmers. This finding is important to recognise because it sets an entry point for closer examination of farmer soil knowledge systems. Farmers were able to clearly delineate plots within their fields, that could match soil variability that was measured. There was an undersanding of soil physical characteristics especially, soil texture and tilth, colour crop production potential and soil

erosion risks. The significant differences between the high and low soil fertility niches identified by farmers for key soil properties, thus justified a qualitative difference in farmers soil categories. Using descriptive knowledge, farmers recognized that soil quality was not uniform over fields and that the differences among soils were readily observable. knowledge systems, which need to be viewed, not as opposing, but rather as complimentary to their own way of thinking.

Acknowledgements

We take this opportunity to appreciate the 60 farmers in Chuka and Gachoka divisions for availing their farms and to participate in the study. The TSBF (Tropical Soil Biology and Fertility) through the folk ecology project availed financial support to enable the study. We appreciate Mwangi Gichovi for support in the field, and Wilson Ngului for helping in laboratory analysis.

References

- Anderson J.M., and Ingram J.S.I. 1993. Tropical Soil Biology and Fertility. A handbook of methods. CAB International, Wallingford UK.
- Arnon I. 1992 Agriculture in drylands. Principles and practice. Elsevier, Amsterdam.
- Arshad M.A. and Coen G.M. 1992. Characterisation of soil quality: Physical and chemical criteria. In: Sparks, D.L. (Ed.) Soil health and sustainability: Advances in Agronomy 56: 1–54.
- Brady N.C. 1984. The Nature and Properties of Soils. Macmillan, NY.
- Brejda J.J., Karlen D.A., Smith J.L., and Deborah A.L. 2000. Identification of Regional Soil Quality Factors and Indicators. Soil Science Society of America Journal 64 2125–2135.
- Carter S.E. and Murwira H.K. 1995. Spatial variability in soil fertility management and crop response in Mutoko communal area in, Zimbabwe. *Ambio* 24 (2):77–84.
- Cheruiyot E.K., Mumera L.M., Nakhone L.N., and Mwonga S.M. 2001. Rotational Effects of Grain Legumes on Maize Performance in the Rift Valley Highlands of Kenya. *African Crop Science Journal* 9(4): 667–676
- Doran J.W. and Parkin T.B. 1994. Defining and Assessing Soil Quality. In: Doran J.W., Coleman D.C., Bezdicek D.F., Stewart B.A. (Eds) Defining Soil Quality for a Sustainable Environment. Soil Science Society of America Special Publication No. 35, Madison, WI, pp 3–21.
- Fairhead J. 1992. Indigenous Technical Knowledge and Natural Resource Management in Sub-saharan Africa: a critical overview. Paper National Resources Institute, Chatham, UK
- Gachene C.C.K. and Kimaru G. 2003. Soil Fertility and Land Productivity. A guide for extension workers in the Africa Region. RELMA, Nairobi.

- Gachimbi L. N., De Jager A. Van Kuelen H., Thurairara E.G. and Nandwa, S.M. 2002. Participatory diagnosis of soil nutrient depletion in semi-arid areas of Kenya. *Managing Africa's Soils* No. 26 IEED.
- Genstat. 1995. Genstat 5 Release 3.2 for Windows 95. Lawes Agricultural Trust, Rothamstead Experimental Station, UK
- Gotway C.A. and Hergert G.W. 1997. Incorporating Spatial Trends and Anisotropy in Geostatistical Mapping of Soil Properties. *Soil Science Society of America Journal* 61: 298–309.
- Halvorson J.J., Smith J.L. and Papendick R.I. 1996. Integration of multiple soil parameters to evaluate soil quality: a field example. *Biology and Fertility of Soils* 21 207–214.
- Hoffmann L., Gerling, D., Kyiogwom, U.B., Mané-Bielfeldt, A. 2001. Farmers' management strategies to maintain soil fertility in a remote area in northwest Nigeria. *Agriculture, Ecosystems and Environment* 86: 263–275.
- Jaetzold R. and Schmidt H. 1983. *Farm Management Handbook of Kenya. Volume II: Natural Conditions and Farm Management Information. Part C: East Kenya.* Ministry of Agriculture/GTZ, Nairobi.
- Kanwar J.S. 1975. *Soil Fertility: Theory and practice.* Indian Council of Agricultural Research, New Delhi.
- Karlen D.L., Wollenhaupt, N.C., Erbach, D.C., Berry, E.C., Swan, J.B., Eash, N.S and Jordahl, J.L. 1994. Crop residue effects on soil quality following 10 years of no-till corn. *Soil and Tillage Research* 31: 149–167.
- Kundiri A.M., Jarvis M.G. and Bullock P. 1997. Traditional Soil and land appraisal on fadama lands in north-east Nigeria. *Soil Use and Management* 13: 205–208.
- Larson, W.E. and Pierce, F.J. 1994. The dynamics of soil quality as a measure of sustainable management. In *Defining Soil Quality for a Sustainable Environment.* (eds J.W. Doran, D.C. Coleman, D.F. Bezdicek, and B.A. Stewart), pp 37–51. Madison: Soil Science Society of America Special Publication No.35, SSSA.
- Lekasi, J.K., Tanner, J.C., Kimani, S.K. and Harris, P.J.C. 2001. *Managing Manure to Sustain Small holder livelihoods in the East African Highlands.* Kellinworth: HDRA publications.
- Liebig M.A. and Doran J.W. 1999. Evaluation of farmers' perceptions of soil quality indicators. *American Journal of Alternative Agriculture.* 14:11–21.
- Mugendi D.N., Nair P.K.R., Mugwe J.N., O'Neill M.K. and Woomer, P.L., 1999. Alley cropping of maize with calliandra and leucaena in the subhumid highlands of Kenya: Part 1: Soil fertility changes and maize yield. *Agroforestry Systems* 46: 39–50.
- Murage W.E., Karanja K.N., Smithson C.P. and Woomer, P.L. 2000. Diagnostic indicators of soil quality in productive and non-productive smallholder's fields of Kenya's Central Highlands. *Agriculture Ecosystems and Environment* 79: 1–8.
- Nandwa S.M. and Bekunda M.A. 1998. Research on nutrient flows and balances in East and South Africa: state of the art. *Agriculture, Ecosystems and Environment* 71:1–4.
- Pawluk R.R., Sandor A.J. and Tabor J.A. 1992. The Role of indigenous soil knowledge in agricultural development. *Journal of Soil and Water Conservation* 47: 298–302.
- Patzel N., Sticher H. and Karlen D.L. 2000. Soil fertility-phenomenon and concept. *Journal of Plant Nutrition and Soil Science* 163: 129–142.
- Richards P. 1985. *Indigenous Agricultural Revolution.* Hutchinson, London, UK.
- Sanchez P.A. and Leakey R.R.B. 1997. Land use transformation in Africa: three determinants for balancing food security with natural resource utilization. *European Journal of Agronomy* 7: 15–23.
- Schjønning P., Elmholt S., Munkholm L.J., Deboz K. 2002. Soil quality aspects of humid sandy loams as influenced by organic and conventional longterm management. *Agriculture, Ecosystems and Environment* 88: 195–214.
- Shaxson T.F. 1997. *Land Quality Indicators: ideas studied by work in Costa Rica, North India, and Central Ecuador.* In: World Bank, UNEP, and FAO. (Eds), *Land Quality Indicators and their use in sustainable agriculture and rural development.* FAO, Rome. pp. 165–185.
- SPSS. 2002. *Statistical Package for Social Sciences Release 11.* Chicago, Prentice Hall.
- Tabor, J.A., Kilambya, D.W. and Kibe J.M. 1990 *Reconnaissance survey of the ethnopedology of Kenya's Eastern Province.* Nairobi: USAID.
- Talawar S. and Rhoades R.E. 1997. Scientific and local classification and management of soils. In: Corbeels, M. Shiferaw, A. Haile, M. (Eds.), *Farmers' knowledge of soil fertility and local management strategies in Tigray, Ethiopia.* *Managing Africa's Soils* No.10. IEED, London, UK.
- Tenywa M.M., Magunda M.K., Payton R.W., Gowing J., Hatibu N., Martin A., Deckers S., Isabirye M., Byalekebya J.B., Oruka F., Amamure, J.O. 1999. In: *Proceedings of the Seventeenth Soil Science of East Africa Society.* pp. 252–259.
- Wardle D.A. 1994. *Statistical Analyses of Soil Quality.* Science 264: 281–282.
- Warner K. 1993. *Patterns of farmer Tree Growing in East Africa: A socio-economic analysis.* Oxford Forestry Institute, Oxford.
- Woomer P.L., Bekunda M.A., Karanja, N.K., Moorehouse T. and Okalebo J.R. 1998. Agricultural resource management by small-holder farmers in East Africa. *Nature and Resources* 34 (4) 22–34.
- Zitong G., Ganlin Z., Wenjun Z., Yuguo Z., and Zhicheng, C. 2003. *Land Use-Related Changes in Soils of Hainan Island During the Past Half Century.* *Pedosphere.* 13 (1): 11–22.

Initiating Rural Farmers to Participatory Research: Case of Soil Fertilization in Bushumba, East of DR. Congo

Paulin Njingulula Mumbeya¹ and Ngongo Mulangwa²

¹Socio-economist, researcher at INERA-Mulungu Station, D.S Bukavu, R.D. Congo, pnjingulula@yahoo.fr, Tel: (243)98675845; ²Agronomist engineer, soil science Researcher at INERA-Mulungu station, nmulangwa@yahoo.fr, D.S Bukavu, RD. Congo, co-author Tel: (243)813176096

Abstract

Low adoption of technologies developed through research in DR Congo shows the need for client-based orientation. The experience of involving farmers in participatory research on soil fertility management in eastern DR Congo focused on knowledge transfer to farmers and build their capacity to take the prominent role in defining research agenda, conducting trials and evaluating results. The farmers were offered several options for increasing soil fertility, results obtained from the study are summarized as following:

A farmer has the capacity to well define and execute a research theme, however to express fully these qualities, farmers require some real hand-to-work training and practices in stead of just explanation in a office-room or class-room. Whatsoever would be the farmers participation in participatory research, the presence of collaborating researcher stand still the prime incentive for technology development and dissemination in farmers rural area. The duration of this practicing and maturation new technology depends on factors that determine farmers' participation, interest of the farmer on the technology, and also, the relationship developed between the farmer and researcher. For out case the minimum duration was three growing seasons in a row. Findings through Farmers' experiments in Bushumba, almost met sound research recommendations

Key words: participatory-research, soil fertility management, hand-to-work training

Introduction

Among principal limiting factors to agriculture in Central and Eastern Africa, especially in the Great Lakes Region, made of Burundi, Democratic Republic of Congo and Rwanda, edaphic constraints may rank third (Lunze, 1988). Originating from volcanic materials, the soils of South-Kivu province (East of DR. Congo) have good potential productivity (Matungulu, 1996; Shoheri, 1989). However, as far as population density the estimation approximates 234 inhabitants/km² (PNUD, 2001), which leads to soil of this province being degraded, because of continuous cultivation, without fallow in general. In the best case there is any fallow it is very short (one growing season). In addition

of their frequent nitrogen deficiency these soils have the characteristic of being general acidic with associate aluminium toxicity. Such soil fertility could be corrected by both chemicals and organic amendments. However high cost of chemicals to correct soil fertility limit access of small resource limited farmers to such alternative solution (Mutombo, 2000). A reasonable alternative solution would be the use of organic fertilizers whose component as prime materials are at hand of all farmers.

Research has during past decade disseminated several technologies capable of helping farmers to lift up their farms' fertility level. According to Lhoste (1989) great amount of technologies generated and disseminated by research station had not been adopted

because it did not meet real peasant user's demand and desire moreover he thinks that farmers could be invited by researchers to participate in agronomic Research from new technologies generation to the dissemination phase. Other authors suggest that Farmer Participatory Research (FPR) be as one approach that enable and encourages farmers to take charge of the agricultural research progress that is meant to improve and sustain their live hoods (Abra, 2001; Shamebo, 1998; Shamebo, 2000).

Some sound field studies done by Action pour le Développement Intégré du Kivu, ADI - Kivu in South-Kivu (Mapatano, 1995) and DIOBASS experiments in Burkina Faso and Cameroun (Jacolin et al., 1990) and Participatory ResearchRIAM in Ethiopia (Abra, 2001) on the ground of participatory research bring forth sufficient proof that peasant farmer posses some assimilation, capacity and initiatives that allow him, if trained, to perform the work one require from him Nevertheless, as stated above peasant participation to technology creation process does not bear all success and advantages.

The aim of this study was to understand, on the first place, how peasant farmer participation in research can be organized building on the Farmers Research Groups (FRG) theory, which, according to Sanginga (2001), is a mechanism to catalyse farmer participation in research and to widen the impact of participatory research. Moreover the study sort to evaluate factors which determine farmers participation and also time, in terms of practices ship duration from which a farmer is able to play one his own initiative the role which devoted to him in participatory research

Methodology

This study took place in Bushumba groups of villages in the territory of Kabare, South-Kivu province, East of DR Congo from August 1999 to December, 2000 or in terms three growing seasons 1999A, 1999B, and 2000A. Climatic conditions of Bushumba are similar to these of the nearly Mulungu research Station, whose precipitation recorded was 739,2., 479,3., and 723 mm for 1999A, 1999B and 2000A, respectively. Season A is the great rainy season whereas season B is the small, little rainy season. Soils of this geographic area belong to B δ -S21 series classified as ferriols humifères and clay developed on basaltic materials (Sys, 1972; Precot, 1960). Smith. (1975) using

US taxonomy classify these soils as Oxlic RhedicPal-endult (Temperatures rank like this: about 25°C and 17°C for average maximum, minimum temperature respectively.

Identification of research issue

Research work for both researchers and farmers commenced by a formal survey in Bushumba, organized by Mulungu Research Station. with the participation of farmers. The objective was to diagnose general agricultural circumstances of Bushumba. Among identified issues, low soil fertility was considered to be part of major constraints to agricultural productivity of Bushumba and was retained by both farmers and the researchers team to be the subject which would be tackled by participatory-research experiments. Thematic researchers and their counterpart peasants partners judged suitable to evaluate altogether the effectiveness of *Tithonia diversifolia* biomass as organic adafic amendment. The search for solutions to the identified issue ended up with research theme definition as following:

- determining the best biomass dose of tithonia biomass to recommend to Bushumba farmers.

Participatory technology generation

The team (both researcher and farmers commenced by sharing conception research theme related about the choise of *Tithonia diversifolia* vegetal. This vegetal was chosen because of: its wides availability in Bushumba as compared to other vegetal capable of giving compost or to sources to other animal sources to make manure.

Table 1. Farmers participation rate on the trial of improving soil fertility with organic fertilizer from *Tithonia diversifolia* (from 1999A to 2000A)

	1999A	1999B	2000A
Participants	100%	50%	30%
Have agreed and applied retained doses from conception meeting	0%	10%	20%
Have not applied agreed doses	100%	40%	

Working process

Experimental design and trial realisation

To facilitate the conception and realisation and evaluation of the participatory research trial, the conception, experimental design, task responsibilities and planning both parties researchers and rural farmers met to set up these useful things: biomass doses to evaluate, measuring unit, spreading techniques, trials sites, plot sizes, were the result of participatory planning and conducting participatory experiment. four treatments were retained in addition to blank (0 dose).1,2,3 and 4 basins of fresh *Tithonia* biomass. The design also of randomised complete Bloc Design (RCBD) amounting approximately: 0, 2, 4, 6, and 8 tonsha⁻¹ of fresh *Tithonia* biomass. Five Farmers per site made up a complete bloc.

The biomass was hand hoed to enter it under ground 7 days before sowing beans, according to research recommendations in the territory (Ngongo, 2000). The blank cultural vegetal used for comparison was common beans, bush type Kirundo variety.

Data (Number of biomasse measures on, plant vigour) uniform plot size of about 4m². were collected at V0,R6 and R7 growing stages or emergence, flowering and growing stages, respectively. Plowing, biomass spreading and sowing were done on each site the same day everywhere to keep the uniformity of evaluation.

Definition of responsibility

Partners' sides responsibilities were defined as following:

- Researchers provide farmers with seeds, training and sharpening recommendation on ways and steps to follow, to achieve trial goals.

- Farmers provide participatory-research committee with land, establish experiment unit and ensure that cultural practices are properly done
- Both partners participate at the conception, experimental design, choice of land, monitoring and evaluation at the end of the trial

Results

Trial monitoring

It can be noticed that among 25 farmers (100%) who started the experiment about evaluating *Tithonia* biomass the first season1999A only 7 farmers (30%) proceeded to complete the agreement through three full growing seasons up to 2000A.

- Campaign 99A people* who participate applied even biomass on the supposed blank plot.
- Campaign 99B* during the following campaign 99B, 50% of the participants dropped: They complained about too much burden (cutting, transport and plowing *tithonia* biomass).
30% applied the same quantity of biomass on each plot of the bloc except the blank plot: 10% worked correctly, but used doses not agreed at the conception and planning meeting.
- At the beginning of the trial, campaign 00A*, participants (30%) asked for a correct Field demonstration as training executed by an agronomist, only after this field demonstration by the agronomist 20% among leading participants succeeded.

Amendment effect on bean yield

The following table shows pertaining available results from this table 2 it is observable large variability of

Table 2. Variability in bean yield as a result of biomass application

Biomasses doses (t/ha)	Rendement (Kg/ha)				
	Muganzo	Mulengeza	Bushumba	Kashusha	Lushenda
0	561.3 e fgh	250.0 h	325.0 gh	643.8 defgh	759.4 cdefg
2	809.4 cdef	431.3 fgh	546.9 fgh	668.8 defgh	1031.0 bcd
5,5	773.8 cdefg	709.4 defg	581.3 defgh	778.1 cdefg	1306.0 ab
8	1538.0 a	1175.0 abc	1197.0 abc	1006.0 bcde	1559.0 a
C.V. (%)	38.64	38.64	38.64	38.64	38.64
Mmean (Kg/ha)	920.63	641.43	662.55	774.18	1163.85

bean yield as response to the same biomass dose not only inter sites but also intra sites replication.

In General, one notice that soil amendment with tithonia biomass has significantly increase bean yield. The increase was in average 150% of none fertilized traitment The best dose was four basin of biomass, the equivalent of 8 tons ha⁻¹ which was appreciated and rated the best by farmers even if it was not very different from result obtained with 3 basins or 6 tons/ha as far as plant vigour was evaluated. Let us say that findings 3 to 4 basins were found by farmers themselves. They approximate 6 to 8 tons, in use by the research Mulungu Station. This fact shows that farmers have good observation and judgement sense.

Conclusion

Large results variability could be explained by differences in cultural practices not uniformly applied by all farmers intra site and inter sites. E.g weeding was done twice in season B and three times in season A at different days and different growing, physiologic stages.

By the end of this experiment we have came up with the following elements:

If farmers agree to work with researcher in participatory-research they are not all willing to execute tasks whose results or goals are planned on a long term. They prefer activities with short-term visible and advantageous results for their survival.

A farmer has the capacity to well define and execute a research theme, however to express fully these qualities, farmers require some real hand-to-work training and practices in stead of just explanation in a office-room or class-room.

Whatsoever would be the farmers participation in participatory research, the presence of collaborating researcher stand still the prime incentive for technology development and dissemination in farmers rural area.

The duration of this practicing and maturation new technology depends on factors that determine farmer's participation, interest of the farmer on the technology, and also, the relationship developed between the farmer and researcher. For out case the minimum duration was three growing seasons in a row.

This work aimed at contributing to transfer knowledge to farmers to allow them play role in new technology development and dissemination process. It was observed that from pragmatic hand-on to work process farmers can after a while produce valuable results.

It is agreed that to achieve better performances the researcher collaborates closely with the farmer during practice ships period. From all the above mentioned agronomic research can invest and find in farmer a valuable partner for developing and disseminating suitable and promising technologies.

References

- Abra K. 2001. Participatory agricultural research processes in Eastern and central Ethiopia, using farmers social network, as entry point, Working document, CIAT, occasional publication, n°33.
- Jacolin et al.1990. Diobass: les paysans et leur terre, Guide pédagogique,ed Jacolin.
- Lhoste P.1989. L'évolution des méthodes de recherche et de recherche-développement sur les systèmes d'élevage en régions chaudes, in recherche-systèmes et développement rural, CIRAD-EMUT, 178p.
- Lunze L. 1988. Effects of the traditional cropping system on soil fertility in South-Kivu, Zaire, in proceeding of the workshop on soil research for Bean cropping system in Africa, Addis-Abeba, Ethiopia, CIAT, pp 30–33.
- Mapatano S. 1995. Pour un mouvement social au Bushi, la roue est-elle à inventer ? ed.Cerdaf., Bukavu, Zaire.
- Matungulu 1996. Cité par Mutombo T. 2000 sélection des génotypes de pomme de terre pour tolérance à l'acidité du sol et la toxicité aluminique à l'Est de la RDCongo, i, in African Potato Association conference proceedings, Vol,5, pp.
- Mutombo T. 2000. Sélection des génotypes de pomme de terre pour tolérance à l'acidité du sol et la toxicité aluminique à l'Est de la RDCongo, in African Potato Association conference proceedings, Vol. 5, pp.
- Ngongo M. 2000. Evaluation de l'effet de Tithonia diversifolia sur la croissance de haricot commun, PABRA synthesis millenium, 2000 ,Arusha, Tanzania.
- Precot 1960, cite par Mutombo op cit.
- PNUD, 2001 Strategie de Développement Agricole, , République Démocratique du Congo, Tomme II
- Sanginga P. 2001. Assessing the quality of participation in Farmers Research Groups in highlands of Kabare, South Western Uganda, in Proceeding of the PABRA millennium Synthesis: A workshop on bean research and development in Africa over the last decade, held at Arusha, Tanzania, May 28-June 1, 2001.
- Shamebo et Terefe Belehu, 2000,Swen Sweet Potato varieties released in farmers' participatory assessment in Ethiopia, in African Potato Association conference proceedings, Vol 5, pp 149–152.
- Shamebo 1998. Promotion of development through extension system: experience from extension effort for the development of wheat in Bale zone of south Eastern Ethiopia, in Journal of extension system, N°17, pp97–104.
- Shohei 1989. Agricultural production and economic structure in the Lake Kivu area, Zaire: food production and traditional farming system technology in the Lake Kivu area. In: Shohei & Mpelend Mubandu (ed), Agricultural and soil in Zaire, college of agriculturak and veterinary medicine, Nihon University, pp1–3.
- Sys, 1972, cité par Lunze, op. cit.
- Smith, 1972, cité par Mutombo, op.cit.

Farmers' participation in soil fertility management research process: Dilemma in rehabilitating degraded hilltops in Kabale, Uganda

Muzira R.N.¹, Kabale farmers' groups, Pali P.¹, Sanginga P.¹ and Delve R.¹

¹CIAT-Africa, PO Box 6247, Kampala-Uganda

Abstract

Participation of farmers in agricultural technology development and environmental management is vital for achieving impact that benefits the rural poor. Women, the main land users and responsible for household food security could improve welfare of the household members with technologies that improve soil productivity thus increasing yields and incomes. Through a facilitated participatory diagnosis, farmers in Kabale district identified soil degradation as the major factor responsible for crop yield decline. Through farmers' participatory market research, several agricultural options for market enterprise development were identified and pyrethrum ranked highest based on market availability, social factors and profitability. Pyrethrum had ready market within the district and would keep men in agricultural production leading to increased household income. Pyrethrum was a new crop to the community and there was need of farmers to learn its agronomy before scaling out. The soils were acidic (pH 4.8) and extractable P was the most limiting nutrient (5.8 mg kg⁻¹). Farmers' selected soil amendment options that were tested on communal plot. A farmer research committee monitored the experiment and collected data while participatory evaluation was to identify farmers' preference for promising technologies. Plants grown under compost and NPK treated soils had highest yields of 350 and 400 kg ha⁻¹ though flower diameter was not significantly different from other treatments. Farmers ranked soil amendment options in the order of lime < wood ash < FYM < Compost < NPK. However, lime was unavailable in the district and its bulky application required intensive labour. Wood ash, FYM and compost were limited in the community and require intensive labour in searching and ferrying them uphill. Fertiliser NPK was most preferred because it is accessible to most farmers who are familiar with it and is also not bulk. NPK had high impact on the pyrethrum, though it could be costly to some households

Key words: Participation, land degradation, community, development, enabling rural innovation, profitability

Introduction

Uganda's economy is mainly based on agriculture that accounts for 50% of Gross Domestic Product (GDP). Today, the sector provides 80% of employment and over 90% of commodity exports. It provides both market and raw materials for agro based and manufacturing industries respectively. Food crop accounts for 71%, export crops 5%, livestock 17%, fisheries 4% and forestry 3% on GDP (Nsubuga, 1994). Nonetheless recent growth in agriculture and market, advances in

crop production sector has been largely based on area expansion rather than intensification with improved agricultural practices (Zake et al., 1999).

In Kabale district in southwestern Uganda small-scale farmland constitutes 80% of land cover equivalent to 138,370 ha most of which is on hill slopes that are intensively cultivated with prominent participation of women (KDLG, 2002). The agricultural system is dominated by labour as the principal input and the common trend of declining crop yields is associated with declining levels of soil fertility caused by nutrient removal in

harvested crops and soil erosion (Mbabazi et al., 2003) without adequate replacement. High food demand and poverty have resulted into increased acreage, at the expense fragile areas (Lindblade et al., 1998). Year mismatch with reference list. Please confirm which one is correct. This has led to excessive surface runoff associated with soil erosion on hill slopes exposing infertile sub soils and sedimentation in the lowlands forcing farmers to abandon their fields, as they do not realize any returns to land and labour invested (Bamwerinde and Place, 2000).

Pyrethrum was first introduced in Kabale district in 1930's to 1950's and was abandoned. Its production was revived and emphasised in 1992 as a new crop among the farming community in Rubaya Sub County, and there was a need for participating farmers to know the agronomy of the crop. Pyrethrum is a crop grown above 2,130 m a.s.l for high quality flowers, an opportunity to rehabilitate degraded hills that are normally well above 2000 m a.s.l. Farmers identified farmyard manure (FYM), compost, lime, wood ash and NPK as possible options of rejuvenating soil fertility and later the best bets would be tried out in individual fields during scaling out.

Insert your objectives

This paper analyses farmers' innovations in soil fertility management and conservation in the context of pyrethrum production in highlands of southwestern Uganda.

Materials and methods

Study area

Kabale, one of the most densely populated (351 persons km⁻²) districts (Raussen et al., 2002) is located in southwestern Uganda between longitudes 29.8° and 30.3° east and latitudes 1.0° and 1.5° south. The relief ranges between 1,800 and 4,000 m.a.s.l. with the highest points being to the southern part of the district. Rainfall is bimodal with the short rains in February-May and long heavy rains in September-December and annual mean of 800–1000 mm (Mbabazi et al., 2003).

The soils on hill slopes are predominantly volcanic and ferralitic in nature with high clay fraction and base saturation. Peat soils occur in the papyrus swamps with low pH values of 2.4–2.7, which render them unproductive. The land is highly fragmented to pieces much smaller than 0.2 ha with average household owning 8–10 plots scattered on different hills. The high demand for wood fuel has resulted into destruction of many

indigenous forests and valuable trees like black wattle (*Acacia mearnsii*) have been lost leaving hills slopes bare and exposed to erosion.

Data collection

Community diagnosis

Through participatory diagnosis with 35 and 25 farmers in villages of *Muguli B* and *Karambo* respectively major constraints in agricultural production and possible options that could be used in interventions were identified. With the help of a facilitator, discussion using a checklist was initiated through brain storming to allow wider participation and more information for clarity obtained through probing. Resource mapping was used to locate community resources and the degraded areas in need of interventions.

Farmers' participatory research group

Two farmers' research groups that conducted research on behalf of the community were *Muguli B Tugwanise Obworo* and *Karambo Tukore* with men : women ratio of 1:1 and 1:2 and membership of 26 and 57 respectively. The groups had several committees like that of marketing that consisted of 2 members (1 man and 1 woman) for *Karambo Tukore* and 5 members (4 men and 1 woman) for *Muguli B Tugwanise Obworo*, and worked closely with the collaborating partner, Africare-Uganda in collecting market information concerning different enterprises selected following the community action plan. The information required included the price, quantity and quality needed, frequency of delivery, alternative buyers in the market and their locations. The information was compiled and fed back to community for enterprise selection and implementation. Monitoring the experiment and data collection were responsibility of research committees composed of 3 men and 3 women for *Karambo Tukore* and 4 men and 4 women for *Muguli B Tugwanise Obworo*.

Experimental set-up and evaluation

Soils were analysed for pH, total N and organic carbon, extractable P, exchangeable bases (Ca, Mg, Na and K) and texture while FYM, wood ash and compost for pH, moisture content and total nutrients (N, P and K) using methods described by Okalebo et al.(2002). Fertilizer NPK (17:17:17) was applied at the rate of 60 kg ha⁻¹ using elemental P, the most limiting nutrient in the soil and the rest soil incorporated at the rate of 10 t ha⁻¹ on dry weight basis.

Two groups depending on the size of the fields demarcated the plots of 10 × 10 and 5 × 5 m. Good

splits were made from old stools of pyrethrum variety P4 from the mother garden, roots cut to a length of 10 cm with a sharp knife removing old thick woody roots and leaving 15 cm of green vegetative top on the split. The splits were planted at spacing of 75 × 25 cm with roots straight down. Weeding was done by hand hoeing to avoid competition from noxious weeds. The research committee collected experimental data that included plant vigour, pests and disease incidences and flower yields. The researchers were also interested in plant flowering, flower size and farmers' participation in weeding the crop in response to market change. Two field days were conducted to evaluate the experiment and performance of the different soil amendments.

Results and discussion

Major causes of declined agricultural production and possible interventions

Soil fertility decline was one of the major factors of agricultural production identified (Table 1). Soil fertility decline was mainly caused by soil erosion, losses

through crop harvests and deforestation. Trenches have been advocated for because they have tremendously reduced surface runoff and trapped fertile soils. They have replaced bunds that were the major soil conservation measures during the colonial days. Earth bunds are common around homesteads with very gentle slope to divert the surface runoff. Over 60% of the plots on hill slopes have portions of the bunds deliberately destroyed in search of fertile soils or collapsed due to excessive soil weight during wet season. Nonetheless, construction of trenches required intensive labour consuming large percentage of useful time that would be used in the conventional work. The weak and the elderly do not construct trenches in their fields resulting into excessive runoff and soil erosion destroying the efforts used to conserve soils on lower slopes.

Crop residues that could be used as mulch or trash lines are used as source of fuel or animal feed in the households and therefore limiting their use in soil conservation. Trash lines are not effective on steep slopes as are easily washed away in the surface runoff. This is exacerbated by the frequent burning that reduces the amount of residues that could be used as surface mulch

Table 1. Major causes of low agricultural production in Kabale highlands

Factor	Major Causes	Interventions	Constraints
Soil fertility decline	<input type="checkbox"/> Soil erosion <input type="checkbox"/> Crop harvests <input type="checkbox"/> Deforestation	<input type="checkbox"/> Trenches <input type="checkbox"/> Trash lines <input type="checkbox"/> Grass bunds <input type="checkbox"/> Hedgerow <input type="checkbox"/> Agro forestry <input type="checkbox"/> Compost and FYM <input type="checkbox"/> Fallow <input type="checkbox"/> Inorganic fertilisers <input type="checkbox"/> Energy saving stoves <input type="checkbox"/> Alternative income projects <input type="checkbox"/> Use of byelaws <input type="checkbox"/> Migration	<input type="checkbox"/> Lack of labour <input type="checkbox"/> Long-steep slopes <input type="checkbox"/> Poor byelaw implementation <input type="checkbox"/> High costs of seeds <input type="checkbox"/> Lack of fuel wood <input type="checkbox"/> Lack of soil inputs <input type="checkbox"/> Fragmented plots <input type="checkbox"/> Lack of credit <input type="checkbox"/> Lack of knowledge <input type="checkbox"/> Poverty <input type="checkbox"/> Limited land
Pre- and post harvest losses	<input type="checkbox"/> Pests and diseases <input type="checkbox"/> Poor storage <input type="checkbox"/> Animal destruction	<input type="checkbox"/> Spraying <input type="checkbox"/> Resistant crop <input type="checkbox"/> Soil fertility management <input type="checkbox"/> Crop rotation <input type="checkbox"/> Community stores <input type="checkbox"/> Home granaries <input type="checkbox"/> Restricted grazing	<input type="checkbox"/> Lack of inputs within community <input type="checkbox"/> Safety <input type="checkbox"/> Fragmented land <input type="checkbox"/> Lack of pastures <input type="checkbox"/> Limited land <input type="checkbox"/> Lack of Information centres
Lack of organised markets	<input type="checkbox"/> Lack of groups <input type="checkbox"/> Lack of market information <input type="checkbox"/> Unreliable buyers	<input type="checkbox"/> Registered groups <input type="checkbox"/> Capacity building <input type="checkbox"/> Market research <input type="checkbox"/> Farmers' research groups	<input type="checkbox"/> Poor members are left out <input type="checkbox"/> Changes in marketing system <input type="checkbox"/> Leadership conflicts <input type="checkbox"/> Low participation in large groups

in some crop fields. Legumes could be planted in areas that are highly degraded such as hilltops to improve soil fertility. Most of these areas are far from home-steads and therefore not easily supplied with FYM and compost.

Herbaceous and shrub legumes could offer an alternative to farmers who cannot afford cost of making trenches. These could work as live barriers to reduce and diverge surface runoff and soil erosion. On stony soils live barriers could be used to save the cost of buying and servicing the tools used in making trenches. With time new contours would be formed as natural terraces develop due to soil accumulations behind the barriers. The shelf life of trenches could be extended with stabilizers that could be planted on the upper banks to reduce siltation. During management of barriers the pruning could be used as green manure in the field or fed to livestock, an incentive of technology use.

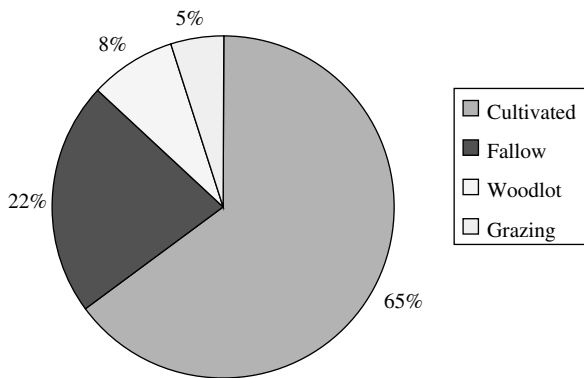

Figure 1. Farmers' perception of agricultural land use

Distribution of agricultural land

Land under cultivation (Figure 1) varies with the seasons with more land being cultivated during rainy seasons. Most of the land is made rest for 1–2 seasons compared to a decade ago when there was low population pressure. Long fallow period is normally 1–3 years and it is with farmers with several pieces of plots. Fallow land under natural grass has some attributes like provision of pasture, medicine and only requires labour during clearing. However, farmers cited problems associated with the natural fallow as delayed fertility rejuvenation, infestation of noxious weeds and short productivity period.

Less land is under improved fallow due to small plots that could not enable rotation, high costs of seeds and their unavailability in the community, lack of information about legume species to plant and their beneficial effects derived.

Woodlots constitute abandoned land mostly hill tops low yields due to soil infertility. Re-write The land is highly degraded with prominent gullies (Figure 2). Some farmers have planted woodlots consisting of mainly *Eucalyptus*, *Acacia mearnsii* and *Grevillea robusta*. Nonetheless, *Eucalyptus* when planted in dense population reduces under growth, which exposes soil to erosion.

Grazing land is found on hilltops with shallow soils, which are degraded and dominated by ferns - good indicator for acidic soils. The hilltops have natural grasses, which are supplemented with *Setaria sphacelata*, *Calliandra calothyrsus*, *Sesbania sesban* and Napier grass which are planted on trenches as fodder for zero grazing systems (Figure 3). They are known together with

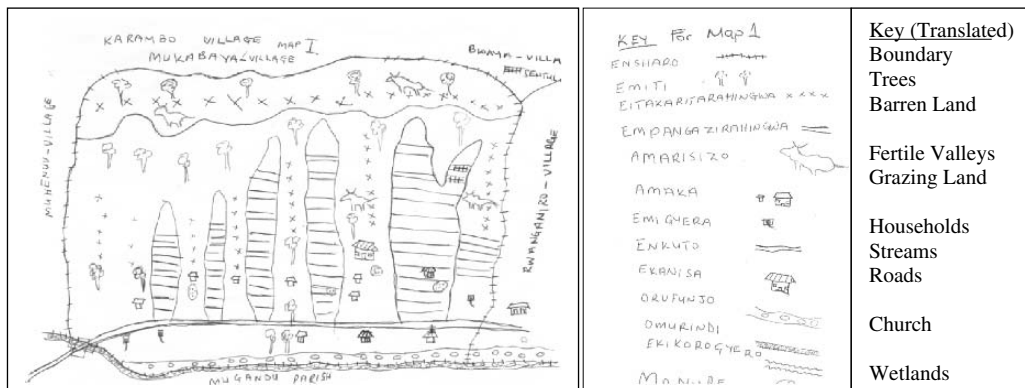

Figure 2. Land resource map in Karambo

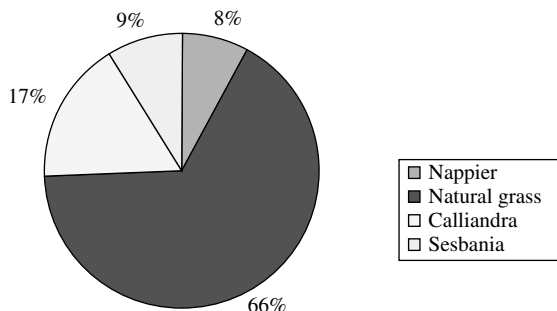

Figure 3. Distribution live barriers used on trenches

natural grasses for easy establishment and fast growing while requiring less labour. Further more these grasses offer thatching and mulching and are efficient in controlling surface runoff where there is no over grazing. Unfortunately they harbour rodents like rats that destroy adjacent crops. Though *Setaria sphacelata* and Napier grass are useful to farming community, much of the landscape has not been covered and a lot of conflicts have resulted from animals destroying the little planted.

Combination of shrub legumes and grasses has proved to be effective in controlling soil loss and diverting the surface runoff. Farmers’ preferred attributes to the shrub legumes were easy establishment,

fast growth, and provision of stakes in case of *Calliandra*.

Distribution of cultivated land under crops

Land area under sorghum and sweet potatoes has remained stagnant due to lack of external market (Figure 4) and are cultivated for home consumption. Land under wheat has dwindled mainly due to unreliable buyer resulting from changes in the market conditions. Land area for major crops has increased in the order of Beans > potato > Maize > Field peas as they are the main source of food in the households and there is ready market within the community, neighboring districts and Rwanda. Due to high market demand of these crops there has been imbalance between production and sustainability due to overexploitation, minimal soil inputs, destruction of grass bunds in search of fertile soils and extinction of some plants.

Among members of the farmers’ groups approximately 30 % use inorganic fertilizer NPK on potato and bean production. The market dictates large sized tubers and farmers realize high profits when fertilizers are used. Fertilizer NPK applied on beans is for root rot management, a common disease in the highlands. About 5% of participating members use FYM, which is applied around homesteads and nearby fields due to its scarcity.

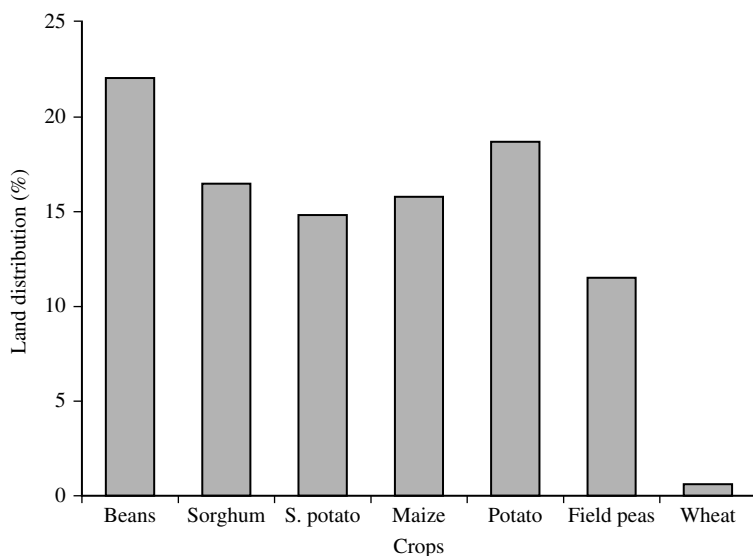

Figure 4. Levels of crop production in Rubaya sub county

Characteristics of experimental soil and amendments

Soil pH (Table 2) was acidic, characteristic of highly weathered soils, which could favour solubilisation of some metal elements such as Al and Mn that are toxic to plants (Dick, 2001) and precipitate out P from soil solution (Muzira et al., 1999). The pH was below the critical value (pH 5.6) for pyrethrum growth that occurs in range of pH 5.5–6.8 with maximum soil P expression (Okalebo et al., 2002). Soil organic matter (SOM) and total N ranged from 5.45 to 6.00% and 0.26 to 0.35%. Extractable P ranged from 5.7 to 5.8 mg kg⁻¹ below the critical level (15 mg kg⁻¹) that could cause plant deficiency symptoms. Exchangeable K ranged from 0.10 to 0.25 me 100⁻¹ g and Ca from 2.14 to 4.43 me 100g⁻¹ and were considered to exist in very low concentrations (Okalebo et al., 2002) while exchangeable Na is not considered plant nutrient for most crops and was below the critical level 1.0 me 100g⁻¹, above which plant growth is negatively affected. Exchangeable Mg ranged from 1.0 to 3.0 me 100g⁻¹ that was rated as high to very high concentration, which could easily antagonise K absorption.

Among the soil amendments (Table 3) compost had high levels of N and it was very low in wood ash and FYM. Nonetheless, wood ash had readily available K and P for plant uptake. The low quality of FYM could be attributed to poor feed given to animals and storage of the material, which led to loss of nutrients through

Table 2. Soil chemical properties of field experiments

Soil property	Muguri B Tugwanise Obworo	Karambo Tukore
pH	4.4	5.4
O.M (%)	6.00	5.45
N (%)	0.35	0.26
Extractable P (mg kg ⁻¹)	5.80	5.70
Exchangeable bases	(me 100g ⁻¹)	(me 100g ⁻¹)
K	0.25	0.10
Na	0.04	0.28
Ca	2.14	4.43
Mg	1.00	1.80
Texture	%	%
Sand	44	42
Clay	32	38
Silt	24	20
Textural class	Clay loam	Clay loam

Table 3. Nutrient composition of soil inputs

Material	pH	% N	% P	% K	% Mg	% Ca
Compost	7.8	2.40	0.58	2.8	0.23	0.29
FYM	8.8	0.30	0.20	0.2	0.20	0.26
Wood ash	13.3	0.07	6.00	40.0	–	–

leaching in the rainy season and volatilisation when hot.

Variation of pyrethrum growth with soil amendments

Flower sampling was done twice both in the rain and dry season and number of flowers was significantly ($P < 0.05$) higher under compost amendment (Figure 5). Compost could have improved upon the soil physical conditions such holding capacity of the soil in addition to nutrient supply. Agricultural lime and wood ash could have improved the soil pH that improved the soil conditions for pyrethrum growth while NPK provided easily the nutrients needed for pyrethrum and more so P that is needed in flower formation

Pattern of farmers' participation in pyrethrum production

At the beginning the crop appeared to be for women since their participation was high (Figure 8). Women tend to work together in groups combining and utilising the available resources in the community and normally are enthusiastic about new technologies coming in to them. Within 2 weeks participation of women and men were equal later the enterprise became men's crop with their high participation in weeding. Nonetheless participation reduced within the first year due to loss of crop to drought. Women's participation reduced gradually compared to men who showed sharp decline in participation. When there was no market for pyrethrum many men's participation dropped further below that of women. Women tended to be more cohesive than women who give up for other options within their reach. Men tend to migrate to neighbouring communities in search for work. Women though their participation also reduced stayed in cohesion with anticipation of good times.

Farmers' evaluation on soil amendments

Farmers' evaluation of the soil amendment was that FYM and compost required intensive labor and yet their plots are far from homesteads on steep slopes and

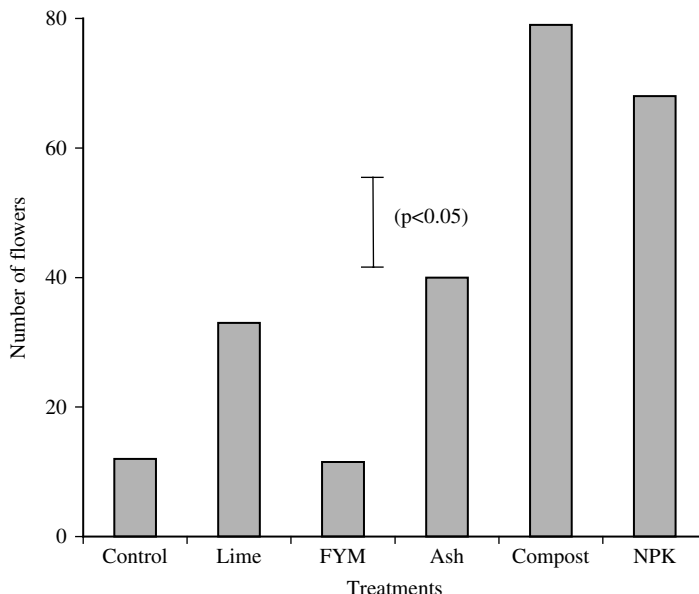

Figure 5. Variation of flower formation with soil inputs

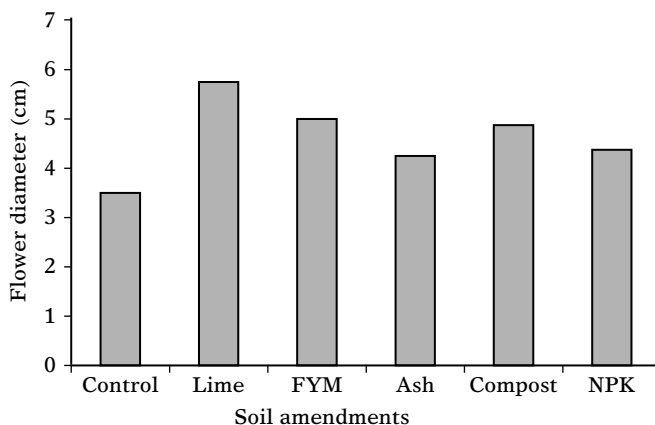

Figure 6. Variation of flower diameter with soil inputs

scattered on different hills. It was difficult to produce the right quantity and quality to administer on larger fields. Nonetheless, these materials would be cheap if home made with adequate materials and animals. Plant responded highly with the compost than FYM application. Wood ash like FYM is not adequate in the communities due inadequate wood fuel caused by wide spread deforestation.

When inorganic fertilizers are applied plants takes a short time to respond and yields are always high with proper distribution of rains that are adequate. Unlike organic fertilizer these do not require intensive

labor, as they are not bulk to carry. Very suitable technology for farmers with pieces of plots scattered on different hills with steep slopes. The major bottlenecks farmers cited with the use of inorganic fertilizer lack of information on the type to use and their application lack within the community for immediate interventions, unprofitable to use on some crops that are not on high demand and high prices for some individuals in the community. However, on the issue of high price most farmers claimed that money spent is easily recovered on crops with high demand.

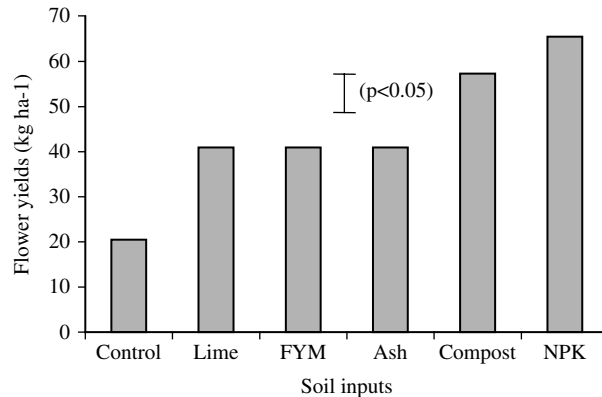

Figure 7. Variation of flower yields with soil inputs

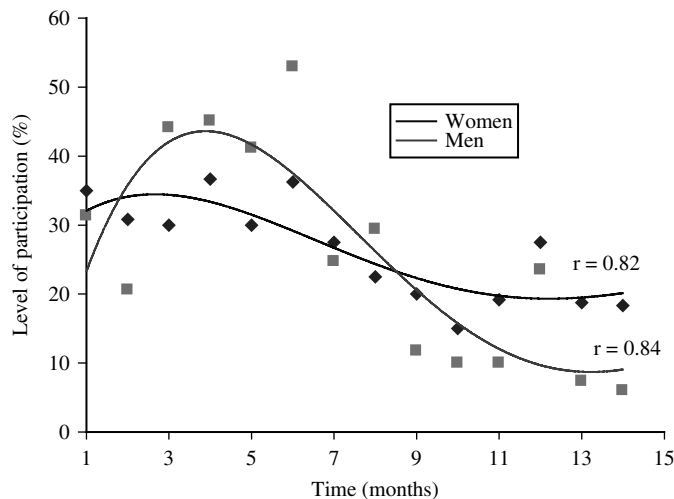

Figure 8. Pattern of farmers' participation in group cultivation and weeding pyrethrum - Karambo Tukore

Conclusions

Most of the soils on hill slopes are infertile and shallow for significant crop production without soil inputs. Farmers were aware the major causes of agricultural production decline as well as the byelaws within the community that would be used in natural resource management. High population pressure has stressed the natural resources in the community where deforestation has taken place; grass bunds destroyed and more fragile land encroached. The main principle input in agricultural system in Kabale is mainly labour that has been used in intensive and extensive cultivation while not minding about environmental sustainability. This has resulted into the trend of declining yield associated with vicious cycle of poverty. Compost and FYM have not been used effectively due to their scarcity

and quality. There is little livestock kept in the community and this cannot produce adequate manure in addition to poor feed used results into poor quality FYM. Most farmers are not aware how to preserve FYM, which results into further deterioration as nutrients are leached and volatilised during the wet and hot periods respectively. Soils that are highly depleted are found on hilltops far from homesteads and their fertility could be rejuvenated with the use of legumes planted either on bund, trenches or as improved fallows. Use of inorganic fertilizers is picking up as number of farmers using it is increasing and this is used mainly in potato production to increase tuber size and yield; and beans to reduce bean root rot.

Trenches have been very effective in controlling soil erosion and diverting the surface runoff. Nonetheless,

these can be effective when the whole landscape is under soil and water conservation. The elderly and the weak (sick) have failed to make trenches in their fields, as this technology is labour demanding and require sufficient time to do a good job. Effectiveness of trenches can be improved when live barriers are planted on the upper banks for stabilisation, trapping soil and diverting surface runoff. Live barrier technology has not spread due to lack of seed within the community, high costs of seed and the effect of grazing animals on the landscape. Soil bunds are used around homesteads to divert the surface runoff and this technology together with trash line is not used in steep areas as they are easily washed away.

During resource mapping it was observed that it were women who understood their soils better spotting areas that are highly degraded and were the ones that were taking the lead in drawing. Some farmers have gained confidence because of group participation though there were low participation rates, a lot of conflicts and more inactive members in large group. Women tended to stay longer in group participation than men. This enables them to continue solving their problems in group and utilise the little resources available in the community.

From the experimental plots, it was NPK, compost that performed well in this highly degraded landscape, and it was contributed to the high concentration of important primary nutrients. Similarly, the biological functioning of the soil may have been altered by addition of compost in terms of changes in micro- and macro-biological populations, which in turn could have influenced plant nutrient availability. Though would ash had high levels of P and K, N was very low and could not give plant high vigour. Would ash may have not improved physical conditions of the soil and its K together with P lost easily through leaching and surface runoff.

The choice of farmers' preference was on inorganic NPK fertiliser because it was available, most members could afford just enough for their small plots and it was easy to carry on steep landscape as compared to other soil amendments. Most farmers were familiar with the inorganic fertiliser as it had high impacts on

the yields and can be used in conjunction with organic fertiliser to cut down further their costs. Organic fertilisers as they are bulky are used in nearby fields while inorganic fertilizers can be taken even in distant plots. Nonetheless, rehabilitating highly degraded land that was once abandoned is challenging if there are no markets for commodities that require ecological conditions of such areas. Farmers are demoralised if the prospect buyers do not take up their products and therefore the efforts of rehabilitating degraded land gets frustrated.

References

- Bamwerinde, W. and F. Place. 2000. Factors Explaining Land Use and Abandonment in Kabale District, International Centre for Research in Agroforestry (mimeo).
- Dick P.R. 2001. soil microorganisms and soil fertility . Soil science society of America and America Society of Agronomy, 677S. Sustaining Soil fertility in West Africa. SSSA special Publication NO. 58.
- KDLG (2002). Three year District Development Plan 2002/2003 – 2004/2005. Volume 1, District Planning Unit, June 2002, Kabale.
- Lindblade K.A, Carswell G. and Tumuhairwe J.K. 1998. Mitigating the relationship between population growth and land degradation: Land-use change and farm management in Southwestern Uganda. *Ambio* 27: 565–571.
- Mbabazi P., Bagyenda R. and Muzira R. 2003. Participatory land degradation assessment in the highlands of kabale district, south-western Uganda p. 82.
- Muzira N.R, Magunda M.K. and Rwakaikara-silver M.C. 1999. Evaluation of the soil physical environment effects on cyanide levels and yield of cassava (*Manihot esculenta* Cratz). *In: Soil science society of East Africa proceedings*, pp.55–66.
- Nsubuga E.N.B. 1994. A critical review of the farmers' response to soil conservation policies in Uganda. *In: The proc. 14th Ann. Gen. Meeting of Soil Sci. Soc. of East Africa, Mbarara, Uganda* pp 1–23.
- Okalebo J.R., Gathua K.W and Woomer P.L. 2002. Laboratory methods of soil and plant analysis. A working manual. P. 128.
- Rausen T., Place F. and Bamwerinde 2002. A survey to identify suitable agricultural and resource-based technologies for intensification in southwest Uganda.
- Zake J.Y.K., Nkwiine C. and Bwamiki. D., 1999. Recent advances in soil management for the coffee/banana farming system in Uganda. *In: The proc. 17th Ann. Gen. Meeting of Soil Sci. Soc. of East Africa, Kampala, Uganda* pp 158–168.

Integrated Soil Fertility Management and Poverty Traps in Western Kenya

J.K. Ndufa^{1*}, G. Cadisch², C. Poulton², Q. Noordin³ and B. Vanlauwe⁴

¹Kenya Forestry Research Institute, Regional research centre, Maseno, P.O. Box 25199, 40108 Otongolo, Kisumu, Kenya (Telephone: 254-57-351164; Fax: 254-57-351592; Email: Jndufa@africaonline.co.ke); * Corresponding author; ²Department of Agricultural Sciences, Imperial College London, Wye, Kent TN25 5AH. Current address: Institute of Plant Production and Agroecology, University of Hohenheim, 70593 Stuttgart, Germany; ³World Agroforestry Centre (ICRAF), P.O. Box 39507, Nairobi, Kenya; ⁴Tropical Soil Biology and Fertility Institute of the International Centre for Agricultural Research, P.O. Box 30677, Nairobi Kenya

Abstract

Based on agro-climatic conditions, the highland districts around Lake Victoria in western Kenya should be a food surplus area. In practice, they are heavily dependent on food imports, whilst national poverty surveys consistently show them to be amongst the poorest in the country. At the root of this problem are high population densities and, therefore, small land holdings, and limited access to markets. As a result of continuous cropping with very little investment in soil fertility replenishment, the soils have become severely depleted. Many poor households in these districts are now caught in a “maize-focused poverty trap”, whereby their first agricultural priority is to provide themselves with maize for home consumption, yet yields are low and returns are insufficient to support investment in either organic soil fertility enhancement technologies or inorganic fertilizers. Thus, despite that the majority of average household puts large portions of its land under maize during both cropping seasons, it is still unable to feed itself for several months of the year. In addition to the problem of low soil fertility, continuous cropping of maize has also led to an endemic infestation of the striga weed throughout these districts, further depressing maize yields.

To invest in soils, most households (unless they have a reliable source of non-farm income) need to diversify into higher value crops than maize. However, the combination of small land holdings and existing maize deficits mean that they will only plant other crops if they can simultaneously raise their maize yields. Achieving this requires that a number of conditions must be in place. Firstly, households must be linked to markets, so that they can identify higher value cropping opportunities and be able to market their crops once they have grown them. In the western highlands, most producers are only familiar with local markets (where opportunities are limited) and they can initially only offer small quantities of produce, which reduces their attractiveness to potential buyers. Secondly, they need technical knowledge, on best cultural practices for the new crops and, critically, on how to manage their natural resource base, so as to increase their yields both of maize and of the new crops.

Thirdly, they need to be able to access good quality seeds of crop varieties that are both suited to their local production conditions and are demanded in the market-place. Finally, most will also need access to credit, so as to be able to acquire inputs for more intensive maize production. This credit can then be repaid out of the sale of the additional crops later in the year. Critically, all these conditions need to be in place within their local area before poor households can hope to shift from a maize-only production system to one that delivers enhanced food and cash, whilst simultaneously enhancing the soil fertility on which future production depends.

This paper reports the experience of a DFID-funded action research project that, since 2001, has been exploring the potential for coordinated development interventions to enhance livelihoods through the promotion of integrated soil fertility management in collaboration with national and international institutes and extension services. Experiences with the provision of technical advice, the development of a community based credit scheme for agricultural inputs, initial steps towards linking farmers to new markets and making new seeds available to producers are reviewed and

constraints identified, along with initial indications of the impact that coordinated service provision could have on agricultural production and livelihoods. Finally, the over-arching challenge of how to coordinate the provision of these services on a sustainable basis is considered

Key words: Integrated soil fertility management, Poverty traps, Access to credit, decision support system, Access to market, quality seed, subsistence farming, rural households, western Kenya

Introduction

Most rural households in Africa are dependent on agriculture for an important part of their livelihood. Increasing farm productivity for the millions of people engaged in agriculture is clearly required for living standards to rise and for these people to come out of poverty. However, land degradation and soil fertility depletion in smallholder farms are serious threats – the fundamental biophysical root cause of declining per capita food production (Sanchez et al., 1997) and a major cause of poverty amongst rural households (Krishna et al., 2004). Large numbers of rural households are trapped in a vicious cycle between land degradation and poverty, and the lack of resources and knowledge to generate adequate income and opportunities to overcome the degradation. Consequently, investments by national governments and the international community have been insufficient to arrest poverty, ensure food security and reduce environmental degradation, as national economies have remained stagnant and the quality of services and governance have deteriorated.

In Kenya, national poverty surveys consistently show the highland districts around Lake Victoria to be amongst the poorest. About 55% of the households in this region were classified poor in 1992, 54% in 1994 and 59% in 1997 (GOK, 2003). Based on agro-climatic conditions, these districts should be a food surplus area. Instead, they are heavily dependent on food imports. At the root of the problem in these districts are high population densities and, therefore, small land holdings (ranging between 0.5 and 2.0 ha per household). Due to continuous cropping and little investment in soil fertility replenishment, the soil has become severely depleted. Neither phosphorus nor nitrogen levels are sufficient for even moderate agricultural performance (Shepherd and Soul, 1998). In addition, small-scale subsistence farmers still lack access to (i) the basic agricultural inputs (fertilizer and good quality seed etc) (ii) capital or credit, (iii) extension service and information and (iv) crops for market.

As a result, many poor households in these districts are now caught in a “maize-focused poverty trap”: their first agricultural priority is to provide themselves with maize for home consumption, yet yields are low and returns are insufficient to support investment in either organic soil fertility enhancement technologies or inorganic fertilizers. Thus, despite the fact that the average household puts a third of its land under maize during both cropping seasons, it is still unable to feed itself for several months of the year (Sanchez et al., 1997). Meanwhile, it earns very little cash income from the land. In addition to the problem of low soil fertility, continuous cropping of maize has also led to an endemic infestation of the striga weed throughout these districts, further depressing maize yields.

There is therefore need to develop an integrated soil fertility management approach (ISFM and integrated agricultural research for development) to assist farmers to fight hunger, reduce poverty and generate economic growth. In turn, this will require coordinated provision of a number of support services. Sanchez et al. (1997) suggested three basic requirements for increasing per capita agricultural production as being (i) an enabling policy environment for the smallholder farming sector (improved infrastructure, access to education, credit, inputs, markets and extension services), (ii) reversing soil fertility depletion, and (iii) intensifying and diversifying land use with high value products

In the highland districts of western Kenya, most households (unless they have a reliable source of non-farm income) will need to diversify into higher value crops than maize if they are to invest in their soils. However, the combination of small land holdings and existing maize deficits mean that they will only plant other crops if they can simultaneously raise their maize yields. They will only be able to do this if they can access the following support services. Firstly, households must have sufficient information about markets to be able to identify higher value cropping opportunities. Currently, many producers are only familiar with local markets (where opportunities are limited). They must also be able to market their crops once they

have grown them. As they will only initially be able to offer small quantities of produce, which reduces their attractiveness to potential buyers, they may also need some facilitation to undertake marketing activities on a group basis. Secondly, they need technical knowledge, on best cultural practices for the new crops and, critically, on how to manage their natural resource base, so as to increase their yields both of maize and of the new crops. Thirdly, they need to be able to access good quality seeds of crop varieties that are both suited to their local production conditions and are demanded in the market-place. Finally, most will also need access to credit, so as to be able to acquire inputs for more intensive maize production. This credit can then be repaid out of the sale of the additional crops later in the year. Critically, all these services need to be in place within their local area before poor households can hope to shift from a maize-only production system to one that delivers enhanced food and cash, whilst simultaneously enhancing the soil fertility on which future production depends.

The objective of this paper was to evaluate the potential for coordinated development interventions to enhance farmers livelihoods through the promotion of integrated soil fertility management in collaboration with national and international (ICRAF, TSBF, etc.) institutes and extension services. In particular, we evaluated (i) the impact of Decision Support Systems (DSS's), (ii) options to diversify *beyond* (as opposed to *out of*) maize, (iii) the introduction and impact of a community based credit scheme, (iv) market opportunities and pricing structures in Western Kenya and (v) the over-arching challenge of how to coordinate the provision of these services on a sustainable basis. These objectives were evaluated based on the experience of a DFID-funded action research project that, since 2001, has been exploring the potential for coordinated development interventions in Western Kenya.

Project background

Since 2001 an action research project funded by the UK Department for International Development's Natural Resource Systems (Research) Programme has been working within the food-crop based land use system in the highlands of western Kenya to pilot a new integrated approach to improving farmers' livelihoods. Building on much previous and ongoing research by many institutions, it is exploring the potential for coordinated provision of support services to enhance livelihoods

through the promotion of integrated soil and crop management.

The project operates in villages of Yala division (Siaya district), Emuhaya division (Vihiga district) and, from 2004, Matayos division (Busia District) and Sigowet division (Kericho Districts). Typically a village contains between 80 and 140 households, a sublocation contains 240–320 households and a location contains 680–750 households or 4–5000 people (Noordin et al., 2002). The project activities were located in existing KARI/KEFRI/ICRAF pilot project village committee (Noordin et al., 2002), Ministry of Agriculture National Agricultural and Livestock Extension Programme (NALEP) Focal Area committees (Baiya, 2000) and Farmer Field School committees sites. The districts have the densest rural population in the world – 500 to 1200 people km² (Hoekstra and Corbett, 1995). The soils in the region are high P-adsorption Alfisols and Oxisols. There are about 6 million people and 2 million farms in the highlands in a total area of 10 000 km² with average farm size of 0.5 ha. Annual rainfall ranges from 1200 to 1800 mm with a bimodal distribution. However, maize yield is often as low as 1 ton ha⁻¹ over two cropping seasons and with households needing > 1000 kg yr⁻¹ of maize for food security, most households are only producing enough maize to feed themselves for a few months. Most household purchase maize on the market during the remaining months or endure a hunger period. About 80% of farms are severely deficient in P and most are deficient in N when P deficiency is overcome (Shepherd and Soul, 1998). Heavy striga infestation occurs in many farms in the region. About 40% of farmers use some fertilizer, but at lower than the recommended rates and often too late for optimum timing of application (Swinkels et al., 1997). Over 70% of households are below the poverty line and depend mainly on subsistence farming (Wangila et al., 1999).

The project encompasses all four areas of intervention highlighted earlier (Figure 1). To enhance technical knowledge, the project is producing and testing a range of decision support tools (DSSs) that present accumulated technical knowledge in farmer-friendly ways. The first DSSs to be produced have been biophysical. The DSSs empower farmers and service providers to carry out nutrient deficiency diagnosis and give corrective measures, give options for striga management and control and lastly give options for better land management for better returns. They stress the importance of combining organic and inorganic inputs, given their complementarities in enhancing soil fertility and the lower

cost and risk involved when compared with relying on inorganics alone. Project staffs are now working on DSSs covering the use of credit and aspects of produce marketing. Farmers are also nominated by their peers to establish pro-active demonstration trials for new innovations and seed varieties obtained from various public organizations and private companies.

Secondly, the project is developing a community based credit scheme for agricultural inputs, known as Sustainable Community-Based Input Credit Scheme (SCOBICS). The SCOBICS scheme was developed together with, and has up till now worked largely through, either village/sublocational or catchment committees. These were originally established either by a previous ICRAF-run project or by the Ministry of Agriculture and Rural Development to support the promotion of agricultural production technologies. Committee members have played a key role in deciding which farmers may deservedly receive credit and in channelling repayment from these farmers back to KEFRI.

Thirdly, initial steps have been taken to link farmers in the pilot areas to new markets, especially in Kisumu. Linking farmers to market has involved price data collection from local markets, price data analysis from Kibuye market, survey of traders at Kisumu markets, farmers' visits to Kisumu market, plus interviews with millers and supermarkets. The data is then discussed with the farmers.

Finally, having identified crops and varieties with potential both at farm and market level – and preferably which contribute to both soil fertility and income-generating objectives – there is the challenge of making seeds available to producers in adequate quantities. Farmers are encouraged to start informal community based seed production systems using the seed obtained from National Agricultural Research Systems (NARS) and International Agricultural Research Centres (IARCs) while discussions are held with the commercial seed production sector.

Experiences to date

Provision of technical knowledge to farmers

Provision of technical support to farmers involved understanding farmers' traditional soil fertility management options and cropping patterns, community based testing of improved cropping innovations and

varieties, farmer visits to various organization and on-farm trials, provision of information on NRM innovation, capacity building and provision of DSS support materials.

Decision support system and cropping patterns

DSS for nutrient deficiency diagnosis and corrective measure, striga management and control and better land management for improved returns were developed and further refined by farmers and extensioners and have been translated into local languages. The DSS are easy to understand pictorial presentations, which depict farmers' cropping patterns and possible interventions obtained from various research organizations to counter farmers' constraints. Both farmers and extension workers are now being trained as resource person on the use of these DSSs. The DSSs were developed and pre-tested with farmers in 2001 in three sub-locations. Subsequently, in other project areas the DSSs were used as training tools DSSs.

DSS have also played an important role in influencing farmers cropping patterns (Figure 1 and 2). Farmers have now diversified beyond maize and they can target landuse constraints through better management of soil fertility management options and targeting of the various crops for high returns. Farmers are now growing market-oriented crops for income and at the same time trying to alleviate soil fertility constraints and striga control.

Participatory evaluation of different seed varieties

Varieties of three crops were tested under farmer-managed trials in the 2003 long rains season, with addition of nitrogen and phosphorous input at recommended rate. These were:

- nine maize varieties obtained from KARI, Kenya Seed Company, Western Seed Company, LAGRO-TECH Seed Company, CIMMYT and input shops (tested on three farms). Striga IR maize was obtained from CIMMYT.
- two groundnut varieties obtained from KARI (tested on two farms)
- four soyabean varieties obtained from KARI and IITA (tested on three farms).

Depending on the variety, maize yields varied between 1.5–2.8 tons/ha on the striga infested farm,

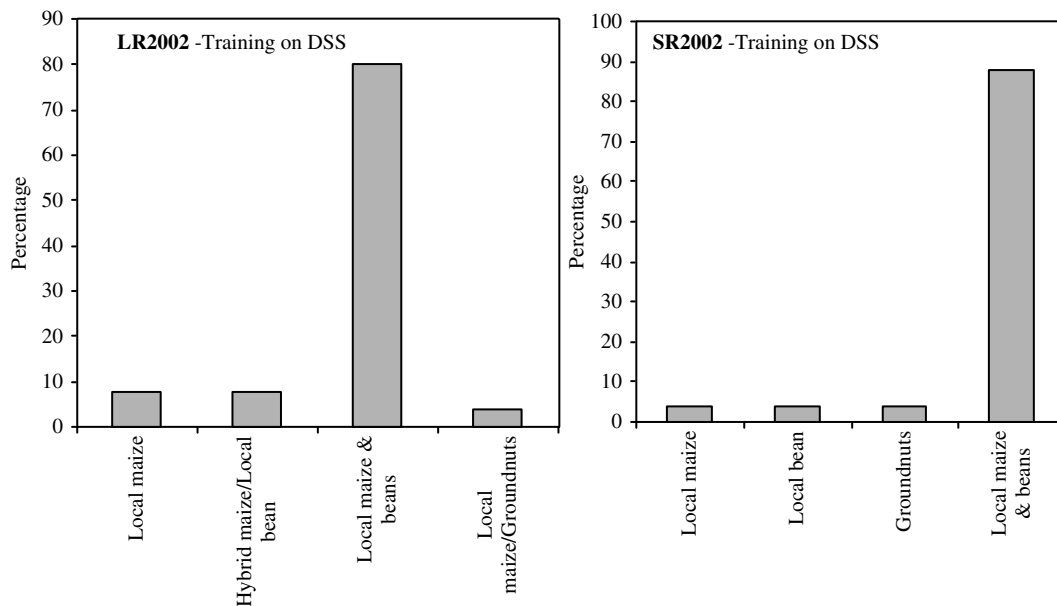

Figure 1. Farmers seasonal cropping system patterns before and during the introduction of DSSs (Decision Support Systems) and participatory farmer designed trials among SCOBICs farmers in Vihiga and Siaya district (n = 99).

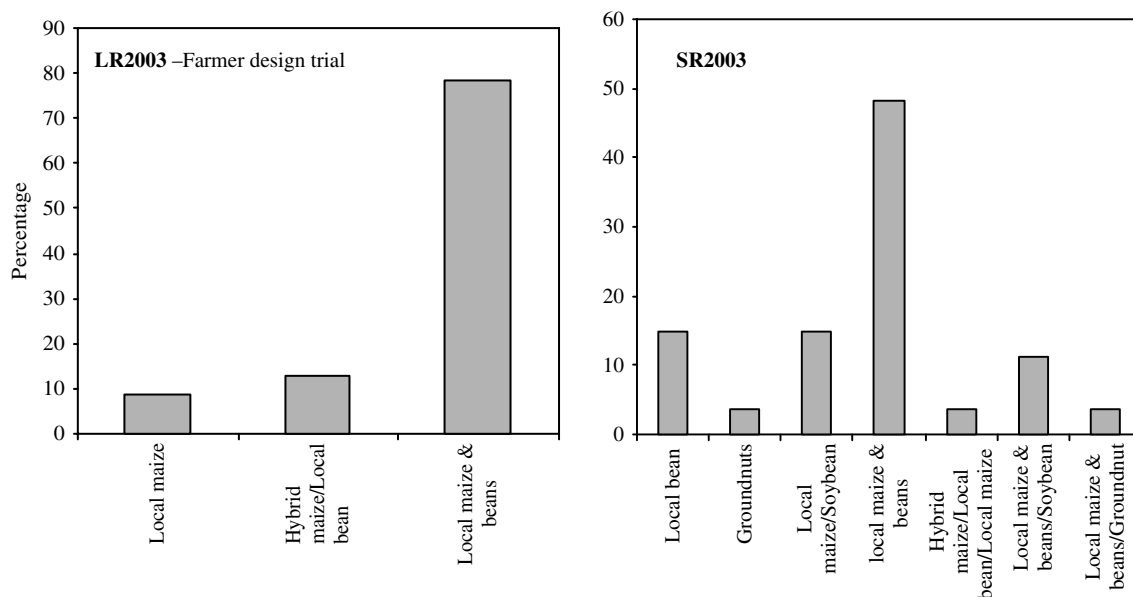

Figure 2. Farmers seasonal cropping system patterns after the introduction of DSSs and participatory farmer designed trials among SCOBICs farmers on cropping patterns in Vihiga and Siaya district (n = 99).

4.1–6.2 tons/ha on the farm previously under *Crotalaria grahamiana* fallow and 2.2 to 6.7 tons/ha on the farm previously under natural fallow (Table 1). Soybean yield varied between 0.8–2.0 tons/ha (Table 2) and groundnuts yield varied between 1.0 to 1.6 t/ha,

depending on location and variety (Table 3). In addition to getting the potential yield under farmers’ conditions, field days were held to get farmers’ evaluation of the different maize, soybeans and groundnut varieties. Farmers’ evaluation criteria included high

Table 1. Yield of different maize varieties (kg/ha) in three farmer managed trial plots in Vihiga and Siaya Districts in long rains 2003

Site/Cropping history/Variety	Yield data (kg/ha)			
	District and Site	Vihiga District R. Amayi farm	Siaya District J.Nyamas farm	Siaya District Z. Liewa farm
Short rains 2002		Maize + striga	Fallow-crotalaria	Natural fallow
H513		1729	4068	2235
H614		2221	5727	4218
ECAVL		1919	5257	6520
WH904		2373	5644	6733
WH502		2499	6082	5998
KSTP94		2205	5431	4176
Pioneer		2789	5030	2800
Maseno double cobber		2202	5445	2261
Local variety		1494	4496	4072
Mean		2159	5242	4335

Table 2. Yields of different soybean varieties (kg/ha) in three farmer managed trial plots in Vihiga and Siaya Districts in long rains 2003

Site/Cropping history/Variety	Yield data (kg/ha)			
	District and site	Siaya District Jerim Otieno farm	Siaya District Joseph Oloo farm	Vihiga District Richard Amayi farm
Short rain 2002		Fallow-crotalaria	Maize + striga	Maize + striga
Nyala (EM)		1200	Eaten by gazelle	800
Hill (EM)		1600	1600	1400
Gazelle (MM)		1400	Eaten by gazelle	1200
TGX1448 2E (LM)		2000	1400	1400
Mean		1550	1500	1200

EM = Early maturing; MM = Medium maturing; LM = Late maturing.

Table 3. Yields of different groundnuts varieties (kg/ha) in two farmer managed trial plots in Vihiga and Siaya Districts in long rains 2003

Site/cropping history Variety	Yield data (Kg/ha)		
	District and Site	Vihiga District Rinah Muchukah farm	Siaya District Peres Ochillo farm
Short rains 2002		Maize + striga	Maize + striga
ICGVSM 88710(Virginia type)		1000	1600
ICGVSM 89749(Valencia type)		1400	1400
Mean		1200	1500

yields, resistance to storms, and tolerance of striga and maturity period (Table 4). The field days and associated evaluations had a strong influence on the demand for seed under the SCOBICS credit scheme for the

2004 long rains also on farmers' cropping patterns, since they acted as a demonstration and training site. Farmers are now growing more market oriented crops (see below).

Table 4. Reasons given by farmers for selecting the best bet varieties of maize, soyabean and groundnuts

Crop	Best bet variety	Reasons given/Farmers evaluation
Maize	WH 502 and WH 904	High yielding, relatively short height withstood storm, weight at harvest was relatively high, good tolerance to striga weed – WH 502 yielded higher compared to other striga tolerant varieties
	KSTP 94	Only advantage was that it matured earlier than western seed varieties. Its tolerance to striga weed was lower than that of WH 502 and this affected yield.
	H614	Only ‘undoing’ is that it takes longer to mature and its height, but with good agronomic practices it yields highly in a striga free environment.
Soybean	TGX 14482E	Produces a lot of biomass which is good for the soil organic matter content, and also yields higher compared to the other varieties.
	Hill and Nyala	Good alternatives for the TGX 14482E variety especially for the short rain season. Their yields are slightly lower than that of the TGX 14482E variety
Groundnut	Virginia type	High yielding variety compared to 89749 variety (Valencia type), which is also highly susceptible to the groundnut rosette that adversely affects yields. The Virginia type variety of groundnuts also fetches a higher amount of money compared to the Valencia type of groundnuts

Access to credit by farmers

Few microfinance institutions in Africa have so far shown interest in providing loans to support smallholder agricultural production, because the seasonal nature of agricultural cash flows does not fit well with their current strategies for ensuring loan repayment. Hence they consider such lending to be too risky (Dorward et al., 1998; Morduch, 1999). In Kenya, however, both the major microfinance institutions, K-REP (based in Nairobi) and Wedco (based in Kisumu) appreciate the importance of developing loan products for supporting seasonal agriculture if microfinance is to increase its contribution to poverty reduction efforts in the country. SCOBICS seeks to develop an effective and viable model for seasonal lending that can ultimately, if successful, be taken on by Wedco as a commercial pilot project.

SCOBICS began with efforts by ICRAF in 1999 to promote the use of rock phosphate fertilizer amongst farmers in pilot villages of Sauri sublocation, Siaya District, through the provision of credit in kind. Under ICRAF management, the pilot credit scheme expanded to take in an additional sublocation (Nyaminia) plus a range of groups associated with the TATRO farmers' organization. It also expanded to support provision of improved maize and bean seeds, as well as the

original rock phosphate (RP) fertilizer. In 2001, the management of the scheme was transferred to the current project, its mode of operation changed and the name SCOBICS was born. Since then, the scope of the scheme has expanded further, as follows:

- the range of products supported has been further expanded to include: TSP fertilizer (2002), DAP fertilizer (2003), urea and CAN fertilizer (2004), soyabean and groundnut seed (2004);
- In 2003, two Ministry of Agriculture and Rural Development extension “focal areas” – Ebukhaya and Gongo – joined the scheme;
- In 2004, three further areas – Ebusiloli (Vihiga), Muyafwa (Busia) and Kaplelartet (Kericho) also joined.

The total amount borrowed in 2004 is Kshs. 545,000 (e.g. US\$ 7786 equivalent).

Up until 2003 the scheme worked through either village/sublocational or catchment committees and these remain the first point of contact for the scheme, including when expanding into new areas. These committees were originally established to support the promotion of agricultural production technologies, either by a previous ICRAF-run project or by the Ministry of Agriculture and Rural Development. Committee members have played a key role in deciding which farmers may deservedly receive credit and in channeling

repayment from these farmers back to KEFRI (formerly to ICRAF). Starting with the 2002 long rains season, each sublocational committee was given an annual credit allocation, based on the previous year's repayment performance, and was given the responsibility of compiling farmers' requirements for RP, TSP and DAP fertilizers, plus maize and beans seed, up to the total sum fixed by SCOBICS. How the committees accomplished this was left up to them, although SCOBICS did specify certain conditions that new borrowers had to fulfill (e.g. having repaid any previous loans, attending the annual Credit Information Day in their area). The compiled requirements were returned to KEFRI-Maseno by the beginning of December and

a competitive tender process was instigated to choose a supplier for the products demanded. The winner of this process (Jumbo Agrovet) was contracted to acquire the required inputs, repackage them as necessary and distribute them to a central location within each of the three sublocations. This distribution took place in early February, in good time for planting in the long rains season.

Table 5 shows the expansion of the credit portfolio and the credit repayment performance by sublocation from 2001–2003. The table shows a mixed picture, with consistently good repayment performance amongst Tatro members, good initial performance from Ebukhaya and Gongo, but mediocre or poor

Table 5. Credit percentage repayment by different sublocations and NALEP focal areas in Vihiga and Siaya Districts

Sublocation/ Village	Amount Borrowed 2001	% Loan Recovery 2001	Amount lent in 2002	Total recovery by 14 November 2003	Amount lent in 2003	% Loan Recovery 2003	Total Amount Lent 2001– 2003	% Loan Recovery Overall	New Lending in 2004
Sauri									
Sauri	7811	69%	21300	40%	0		29111	48%	
Soso	5343	35%	18652	46%	0		23995	43%	
Nyamninia	2727	36%	16800	2%	0		19527	7%	
Luero	17028	12%	15552	14%	0		32580	13%	
Kosoro	4632	23%	10736	0%	0		15368	7%	
Yala	5735	12%	9510	8%	0		15245	10%	
Sarika	0		14502	0%	0		14502	0%	
Madiri	5938	24%	11436	17%	0		17374	19%	
<i>Total</i>	<i>49214</i>	<i>27%</i>	<i>118488</i>	<i>19%</i>	<i>0</i>		<i>167702</i>	<i>21%</i>	<i>0</i>
Nyamninia									
Muhanda	10342	86%	40748	66%	0		51090	70%	
Nyamboga	4950	100%	30526	50%	0		35476	58%	
Umiru	550	73%	2764	4%	0		3314	15%	
Ginga	0		6452	12%	0		6452	12%	
Muhoho	2745	65%	22652	43%	0		25397	45%	
<i>Total</i>	<i>18587</i>	<i>86%</i>	<i>103142</i>	<i>51%</i>	<i>0</i>		<i>121729</i>	<i>57%</i>	<i>30000</i>
Tatro	<i>24000</i>	<i>100%</i>	<i>108958</i>	<i>100%</i>	<i>0</i>		<i>132958</i>	<i>100%</i>	<i>150000</i>
Gongo					<i>47040</i>	<i>100%</i>	<i>47040</i>	<i>100%</i>	<i>100000</i>
Ebukhaya									
Emabuye					22119	100%	22119	100%	
Emukunzi					10134	100%	10134	100%	
Musikoye					9494	100%	9494	100%	
Musitoyi					15453	100%	15453	100%	
<i>Total</i>					<i>57200</i>	<i>100%</i>	<i>57200</i>	<i>100%</i>	<i>115000</i>
Ebusiloli									50000
Kaplelartet									50000
Muyafwa									50000
Total SCOBICS	91801	58%	330588	56%	104240	100%	526629	65%	545000

performance in Nyamninia and Sauri. In 2003 Sauri, Nyamninia and Tatro were not eligible for credit, as they had not met the repayment conditions from 2002 (Tatro completed its repayments too late for the 2003 tendering process).

The main incentive mechanism for ensuring credit repayment under SCOBICS is the linkage between current repayment performance and future credit access. Up till 2003, this mechanism operated at the sublocational level. Thus, a sublocation that failed to achieve 80% repayment performance in a given year was not eligible for credit at all the next year, whereas a sublocation that repaid in excess of 99% of its loan could double the volume of credit that it received the next year. Intermediate repayment rates qualified for intermediate credit volume ratios the following year. By the end of 2003, it was concluded that incentives for repayment were insufficiently strong under this model, for the following reasons:

- Some committees were not as strong as originally hoped;
- In some cases (especially Sauri and Nyamninia), inadequate attention was given to screening. Indeed, in parts of Sauri, the loans were described to potential borrowers as “government money” that would not need to be repaid;
- The general level of awareness about loan repayment is too low and the numbers of borrowers involved is too large for the incentive system to work at sublocational level. Where (as in Sauri and Nyamninia) no one really believed that 80% repayment would be achieved by current borrowers, even those who would have been willing to repay in order to gain access to future loans held back, as repayment would not be rewarded with future credit access under SCOBICS rules.

Therefore, beginning in 2004, SCOBICS moved to a new, small-group-based lending model, with the same mechanism linking current repayment performance and future credit access now operational at the group level. Existing borrowers within the scheme who had repaid all their loans in full, plus new borrowers joining the scheme, were required to organise themselves into groups of 5–10 (who would be judged collectively on their repayment performance) as a precondition for receiving a loan in 2004.

The change was greeted with considerable enthusiasm, both by individuals who now felt freed to repay their loans, unburdened by responsibility for others in their sublocation, and by committee members, who

had despaired of persuading a sufficient number of borrowers to repay in order to meet the sublocation-level targets. It was noted that some of the women in these areas already had experience of giving each other loans within small groups and that this works fine as long as group members select each other. However, in practice, the few borrowers from Sauri who had repaid their loans and attended the Credit Information Day were unable to agree to form groups together, as they did not trust each other sufficiently to be judged collectively on their repayment performance. Thus, no new loans were extended in Sauri in 2004, although some 2002 borrowers from Nyamninia did re-enter the scheme.

The group-based approach is closer to Wedco's current lending approach than the committee-based approach that was tried previously. However, the SCOBICS incentive structure is different from that operated by Wedco, who use a mutual liability approach originally pioneered by Grameen Bank. Both theory (Stiglitz, 1990) and experience suggest that the Grameen-style approach has shortcomings when applied to rainfed smallholder agriculture (one of the reasons why SCOBICS did not adopt it at the start of the project). The SCOBICS incentive structure, applied at small group level, may have superior incentive properties to the Grameen-style approach in bad years, but these theoretical properties still need to be tested out in practice.

Meanwhile, experience has also shown the importance of providing training to both individual borrowers and committee members if acceptable repayment levels are to be achieved. Wedco staff were invited to provide training to borrowers in 2003, which appears to have paid dividends.

Accumulated experience has also generated the following guidelines for screening loan applicants in 2004:

- All applicants should be required to work through the relevant DSSs with a resource person before being approved for a loan.
- The need to plant higher value crops should be stressed to all potential borrowers. A simple rule could be that no one is allowed a loan without a clear plan to plant one or more higher value crop(s) intended primarily for sale across the two seasons.
- Borrowers should be encouraged to think carefully about the expected (financial) benefits of taking a loan. If these are not twice the cost or more, then they should not borrow.

Each borrower should be able to suggest two or three plausible ways of repaying their loan *before* they are allowed to borrow. Where two options are crop-based, ideally one should be related to long rains production and one to short rains production. At least one option should be unrelated to crops, in case both long and short rains seasons are bad.

Looking forward, there are grounds for optimism that the small-group-based lending model, plus additional training inputs from Wedco and generally enhanced awareness of the importance of screening loan applicants, will generate good repayment performance in 2004. If so, it is possible that by 2006 the scheme could be close to its target loan portfolio of KES 2 million.

Handing over to a specialist microfinance provider such as Wedco will, however, require changes to scheme operation, even if the basic loan product (seasonal loan, delivered to borrowers organised in groups, with the SCOBICS repayment incentive scheme) is adopted unchanged by Wedco. In particular, it is unlikely that a specialist microfinance provider would be willing to organise the tendering process for input supply that SCOBICS has arranged each year. A possible solution to this problem is the introduction of input vouchers, redeemable at recognised stockists, that is being considered by CNFA, an NGO preparing to work with input stockists in the area.

Linking farmers to markets

This dimension of the project featured less prominently in the project concept and proposal than the biophysical work (e.g. DSS development) and credit provision and, partly as a result, implementation began later. With the benefit of hindsight, this was a mistake. Having seen the performance of new crops and varieties in their fields, obtained access to input credit and begun to understand the importance of growing higher value crops alongside maize, farmers are keen to plant new crops, even though the market prospects for these have yet to be convincingly established.

Efforts to link farmers to market began with a series of market research exercises, plus initial efforts to familiarise selected farmer representatives with the major, informal wholesale and retail markets in Kisumu. Having been producing predominantly maize and local beans, and generating insignificant marketed surpluses, many producers in the project areas are only familiar with local markets. As opportunities in these

markets were perceived to be limited, it was decided to explore opportunities within Kisumu markets (not too far away, not too demanding in quality terms) as a first step. Market research exercises covered both price monitoring (of crops in local markets, plus price data analysis from Kibuye market in Kisumu) and a survey of traders at Kisumu city markets that aimed to understand the structure and conduct of these markets, given farmers' fears that (as inexperienced outsiders) they could be exploited by traders in these markets, even if they had produce that they could sell profitably at prevailing market prices.

So far, price analysis has only been conducted on three crops: maize, beans and groundnuts (as there have been difficulties establishing reliable unit weights for other commodities in local markets). Figure 3 shows weekly wholesale prices (in KES per kg) for maize in three local markets – Luanda, Yala and Siaya – over a one-year period commencing January 2003. It shows that the highest local price, achieved in mid-July, was around 90% above the lowest, achieved in January–February and September–October. This represents a similar degree of intra-seasonal price variability to that observed in other countries of Sub-Saharan Africa in areas with unimodal production (Coulter and Onumah, 2002) and a much higher degree of intra-seasonal price variability than is observed locally for beans and groundnuts. It may, therefore, provide one explanation for why most households in Siaya and Vihiga put maize production as their first priority. For local surplus producers, maize marketing between June and early August would fetch the highest prices, after which the prices fall drastically due to widespread harvesting of maize planted in the long rains. The short rains maize harvest between December and early January does not appear to influence local market prices for maize.

Similar price series were generated for beans and groundnuts in local markets and also for wholesale buying prices of these three crops in Kibuye (Kisumu) market. Costs of transporting crops to Kibuye were also estimated, then the net price to the farmer from selling into the different markets was compared. To the initial surprise of the project team, in virtually every week in 2003, this showed that producers in the pro. Table 6 shows the annual average prices obtainable in the different markets.

Three observations flow from this initial analysis. Firstly, it reminds us that the project areas are actually deficit areas in terms of all three commodities. The net flow of produce is into the area from other parts of the country (or, in some cases, Uganda [Uganda is

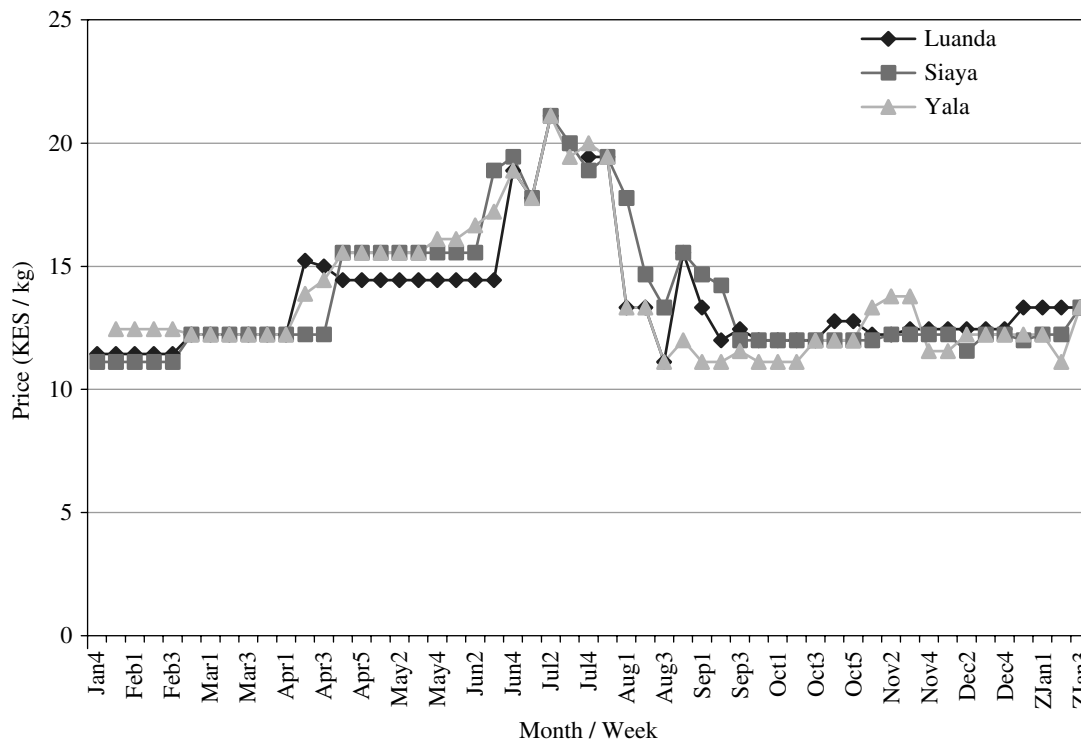

Figure 3. Wholesale prices of white Maize in Luanda, Siaya and Yala markets in the year 2003.

Table 6. Comparing market options (annual average prices) in local and regional markets

Comodity	Wholesale Buying Price	Local Market Price	Difference	Transport	Final Margin (KSh/kg)
White Maize	13.3	14.0	-0.7	1.9	-2.6
Beans (Wairimu/ Canadian Wonder)	21.7	29.6	-7.9	1.9	-9.8
Groundnut	61.9	70.4	-8.5	1.7	10.2

usually believed to supply the Kenyan market which is usually not self sufficient]). Hence, local producers selling at local markets receive a local “import parity price” (the selling price at an external market plus the costs of transporting produce into the area). By contrast, to sell to Kisumu, they would have to accept a local “export parity price” (the buying price at Kibuye minus the costs of transporting produce from the area to Kisumu). As illustrated in Figure 4, the difference between the “import” and “export parity price” in 2003 was 19–32% depending on the commodity.

Secondly, whilst this presents a challenge to producers seeking higher prices for their produce

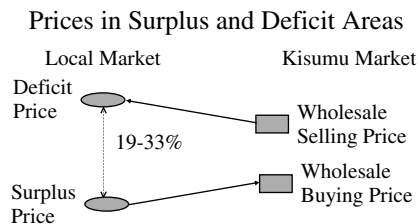

Figure 4. Prices of maize in price surplus and deficit areas in western Kenya.

to encourage them to intensify their production, the difference between the “import” and “export parity price” gives an indication of the magnitude of the price benefits to local consumers if locals producers do

successfully intensify, such that the area realises its natural potential as a surplus area. A fall in the real price of staple foods of 20–30% would represent a major gain for poor households that struggled to participate in the intensification process, so remained net food consumers. Participatory wealth ranking (see below) classes up to two thirds of all local households in the very poor category. Whilst some of these are engaging with project activities, many might realise their main benefit from the project (and from complementary initiatives in the same area) through food price falls if intensification leads to the area becoming net food surplus.

Thirdly, whilst most farmers talk of transport cost as a major hindrance to selling in the regional (Kisumu) market, the difference between the wholesale buying and selling prices of major crops in Kisumu markets is greater than the per kg transport cost incurred by producers in the project area if they seek to sell to Kisumu. This casts the spotlight (for further investigation) on the structure and conduct of Kisumu markets. Certainly, it is widely believed by farmers that restrictive practices by wholesalers are commonplace in these markets.

Meanwhile, the project will seek to analyse prices of other commodities across local and Kisumu markets, to confirm that the findings for the first three crops hold for other crops, too. It will also continue to explore opportunities for selling direct to agro-processing millers and supermarkets in Kisumu. Assuming that some farmers can, in theory, gain by selling to Kisumu, the next step will be to undertake action research to test whether or not farmers *do* actually benefit from doing so, by getting them to try this and seeing what happens.

If no immediate market opportunities open up, the price differential between local and regional markets gives an indication of the extent to which farmers have to increase productivity through their intensification efforts before these efforts provide a financial return. The outcomes of the field trials reported above, plus findings reported below suggest that a productivity increase in excess of 20–30% is indeed achievable.

The seed system and community seed bulking

The typical small scale farmer combines a wide range of crops and varieties to meet their diverse objectives. A major challenge faced by farmers is availability of seed both in quality and quantity. Farmers may identify a promising variety during on-farm trials, but there can then be a long delay before it is commercially available

in their area. This is partly due to the restrictive government policies towards seed registration and partly to the inherent lack of coordination between public research and commercial seed producers in bringing new varieties to market.

Availability of good quality seed can, however, lead to increased crop productivity. In the project, certain farmers were nominated by group members to bulk new seed varieties for other farmers. In 2003, informal seed production systems were established with 38 farmers selected in the project area. The seed was later distributed to over 80 farmers and to over 20 farmers in the new project areas. By achieving a successful seed security and multiplication system, the formal seed sector can then initiate commercial seed systems [explain potential success, sustainability, processes used to ensure both]. Farmer seed production was also used for on-farm demonstrations where farmer field visits, field days and training sessions are held with villagers.

Impact of project activities

As the previous sections have explained, the full range of coordinated interventions to support production intensification and diversification *beyond* maize have not yet been put in place by the project. Moreover, a formal assessment of the project's impact has yet to be conducted. Here, therefore, we just provide some initial indications of:

- Who has been able to access credit through SCOBICS
- The impact of project activities on maize and bean yields
- The impact of project activities on crop diversification.

Participation in SCOBICS

In 2002 a socio-economic survey was conducted to characterize farmers participating in SCOBICS during the 2001 and 2002 seasons. 263 borrower households in the study area were interviewed. Decision makers were both male and female; 58% of those interviewed were men and 42% were women. Fifty percent of the households were male-headed household monogamous, 16% male-head household polygamous, 4% female headed household absentee husband, 17% female-headed household monogamous window

and 11% female-headed household polygamous windows. Decision on whether to acquire input credit were mostly made by household heads. About 10% of the farmers were illiterate while the majority of farmer had acquired primary education.

Wealth ranking exercises were also conducted to gauge community perceptions on the wealth endowment of borrowing households. These in turn were compared with outcomes of previous exercises in the same or adjacent communities that were unrelated to SCOBICS. Key local indicators of wealth endowment included: household farm size; source of income; type of housing; number of meals per day; type of food; employment records; children status in society; whether the household hires on-farm labour or not; the number of local/hybrid cattle that the farmer owns; the level of education of the household head; and whether any household member has non-agricultural employment. Based on these identified indicators of wealth, it was found that about 9% of borrowers were considered to be rich, 47% average and 45% poor. This compares to figures of 14% rich, 23% average and 63% poor for the area as a whole, showing that average farmers are disproportionately targeted by the credit scheme. Poor households are under-represented in SCOBICS, but not by as much as might be expected or feared.

Impact of project activities on maize and bean yields

The majority of farmers who got fertilizers on credit applied them on maize. In Gongo and Ebukhaya 33% of the farmers apply phosphorous at the recommended rate of 21 kg P ha⁻¹, but only 10% of the farmers in Nyamninia, Sauri and Tatro applied the recommended rates. The rate of N application among farmers in all the sublocations was found to be below the recommended 60 kgN ha⁻¹. For all farmers. Application of nitrogen ranged from 0–5 kg ha⁻¹ for 40 % of the farmers in Nyamninia, Sauri and Tatro. In Gongo and Ebukhaya 33% of the farmers were found to be applying 18 kg N ha⁻¹ giving credence to the conclusion that these farmers apply nitrogen only at maize planting and do not meet the short fall at topdressing stage of maize growth. It should however be noted that these figures reflect the application from inorganic sources only. Other sources of N that farmers use include compost and animal manure but a large amount of these are required to meet the shortfall and the poverty levels in the region have limited livestock ownership. In some areas these organic manures are prepared for sale to farmers without livestock further limiting acquisition of these nutrient sources by resource poor farmers. Credit availability increased maize yield by 750 kg

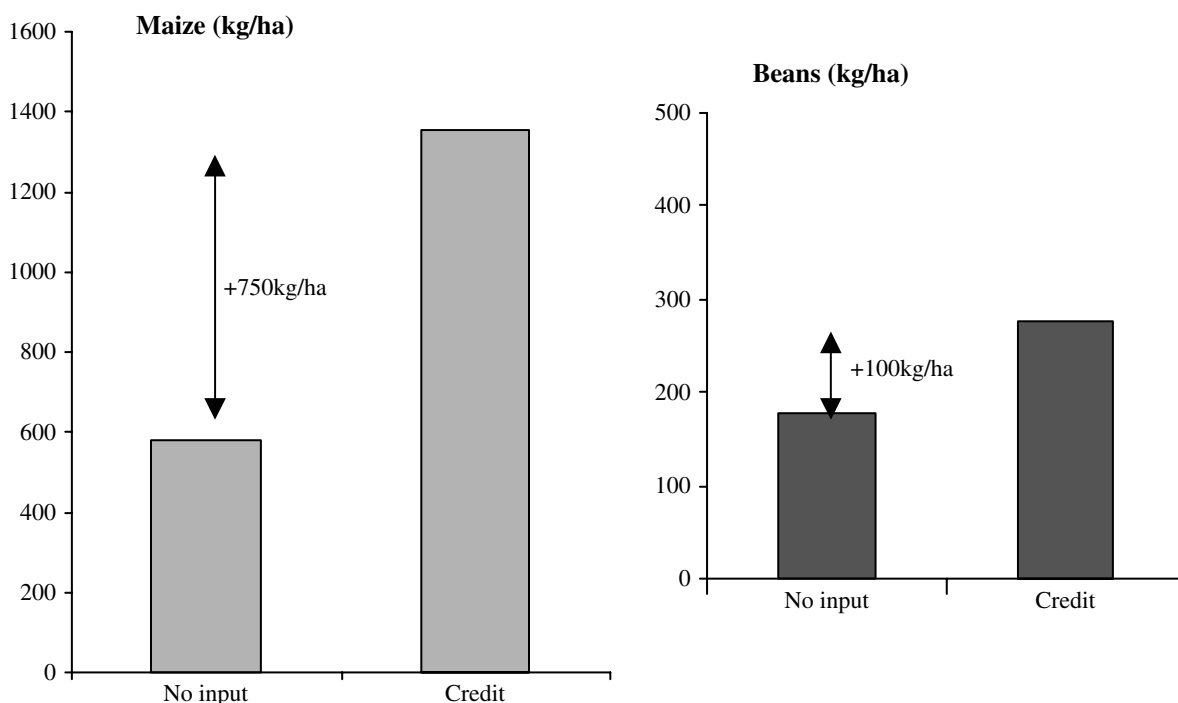

Figure 5. Effect of credit to crop yield on maize and bean yield in Vihiga and Siaya district (n = 99).

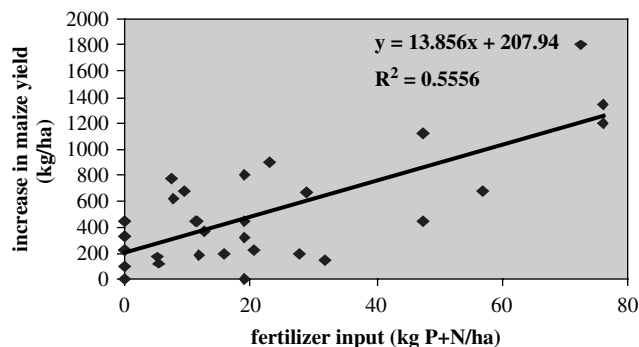

Figure 6. Regression analysis for increase in maize yields (kg ha^{-1}) against unit application of P + N (kg ha^{-1}) in Vihiga and Siaya district.

ha^{-1} and 100 kg ha^{-1} for bean mainly in Gongo and Ebukhaya sublocations (Figure 5). Low increases were attributed to the often poor fertilizer application rates below the recommended rate.

Maize yields increased apparently linearly with unit application of P+N nutrients for Gongo, Ebukhaya, Tatro and Nyamnia sublocations respectively, although large differences between individual fields were observed (Figure 6). In Gongo and Ebukhaya it was noted that without application of *both* P and N there would be no increase in maize yields. The regression on the other hand estimated that on average 207 kg of maize would be the yield per hectare without application of both nutrients. Overall, it was noted that the yield increase per unit fertilizer was much lower than expected and profitability marginal. This suggests that, apart from the above mention low and poorly balance fertilizer applications, further evaluations on reasons for this poor response is required.

Outlook – or how to coordinate the provision of these services on a sustainable basis

This paper has discussed the challenges entailed in developing a new integrated approach to improving farmers livelihoods that can be used to get farmers out of poverty through increased farm productivity through successful use of DSSs and credit scheme. However, more work is needed particularly on the marketing front before the action research project can say that it has tested its hypothesis about the impact of coordinated service provision on small farm crop management, livelihoods and poverty.

The preliminary findings suggest that provision of coordinated extension services, provision of

integrated soil management options, farmer linkage to markets and credit may provide an avenues to escaping from maize focused poverty traps. So, let's assume that – with access to remunerative markets plus the credit necessary to invest in the fertility of their soils and to obtain improved seeds – farmers are able *both* to increase their maize production *and* to sell other crops for cash (i.e. to diversify *beyond* maize, as opposed to *out of* maize). How might provision of the necessary coordinated set of services to poor farmers in western Kenya be ensured after the life of the project? A mechanism is needed to bring together output buyers, credit providers and seed suppliers (all from the private sector) with researchers and extension workers (mainly public sector) to support farmers in particular communities or sub-locations to diversify beyond maize. Technology transfer alone are not sufficient to ensure widespread technology adoption. The right institution and coordinated service provision need to be in place to provide local incentives for investment. The COSOFAP consortium of organisations involved in development in western Kenya may be able to encourage the necessary coordination. Alternatively, district development planning processes may be the appropriate mechanism for encouraging such coordination. Our observation is that this is an issue that has yet to receive serious policy consideration. However, it could be central to assisting poor farmers in western Kenya to escape the maize-focused poverty trap in which they currently find themselves.

Government, NGOs, private sector, international organization need to work and development partners need to work effectively with communities recognizing multiple and informal rights and opportunities for strengthening households social capital for collective action of farmers.

References

- Baiya, F.M. (2000). Focal Area extension planning: NALEP Field Guide – Notes. MoARD, Nairobi, Kenya
- Coulter, J. and G. Onumah (2002). “The Role of Warehouse Receipt Systems in Enhanced Commodity Marketing and Rural Livelihoods in Africa.” *Food Policy* 27(4): 319–337.
- Dorward, A., J. Kydd and C. Poulton (1998). Smallholder Cash Crop Production Under market Liberalizaion: A New Institutional Economics Perspective, CAB Internation, Wallingford.
- GOK (2003). Kenya:Interim poverty reduction strategy paper 2002–2003, available at <http://poverty.worldbank.org/files/Kenya%20IPRSP.pdf>
- Hoekstra, D., and J.D. Corbett (1995). Sustainable agricultural growth for the highlands of East and Central Africa: Prospects to 2020. Int. Food Policy Res. Inst., Washington, DC.
- Krishna A., Kristjanson P., Radeny M., Nindo W. 2004. Escaping Poverty and Becoming Poor in Twenty Kenyan Villages. *Journal of Human Development*, Vol. 5, No. 2: 211–220.
- Morduch, J (1999) The Microfinance Promise. *Journal of Economic Literature* XXXVII 1569–1614.
- Noordin, Q., Niang, A., Jama, B. and Nyasimi, M. 2001. Scaling up adoption and impact of agroforestry technologies: experiences from western Kenya. *Development in Practice*, Vol. 11, No. 4: 136–155
- Sanchez, P.A., Izac, A.-M., N., Buresh, R.J., Shepherd, K.D., Soule, M., Palm, C.A., Woome, P.L., and Nderitu, C.G. (1997b). Soil fertility replenishment in Africa as an investment in natural resource management. In “Recapitalization of Soil Nutrient Capital in Sub-Saharan Africa” (R.J. Buresh and P.A. Sanchez, eds). ASSA, CSSA, SSSA, Madison, Wisconsin.
- Shepherd, K.D. and M.J. Soul (1998). Assessment of the economic and ecological impacts of agroforestry and other soil management options on western Kenya farms using a dynamic simulation model. *Agric. Ecosy. Environ* 44: 1–12
- Stiglitz, J (1990) Peer Monitoring and Credit Markets. *World Bank Economic Review* 4(3): 351–366.
- Swinkels, R.A., Franzel, S., Shepherd, K. D., Ohlsson, E., and Ndufa, J.K. (1997). The economics of short rotation improved fallows: Evidence from areas of high population density in western Kenya. *Agricultural Systems* 55, 99–121.
- Wangila, J., R. Rommelse and De Wolf, J. (1999). An insight into the socioeconomics of agroforestry client-farmers in western Kenya. ICRAF Pilot Project Report No. 12

Moving methodologies to enhance agricultural productivity of rice-based lowland systems in sub-Saharan Africa

M.C.S. Wopereis¹ and T. Defoer²

¹*An International Center for Soil Fertility and Agricultural Development (IFDC) – Africa Division, BP 4483, Lomé, Togo;*

²*The Africa Rice Center (WARDA), 01 BP 4029, Abidjan 01, Côte d'Ivoire; current address: International Center for development oriented Research in Agriculture (ICRA), Agropolis International, Avenue Agropolis, 34394 Montpellier, France*

Abstract

The irrigated and rainfed lowland production systems in sub-Saharan Africa offer great potential to improve food security in the region. Rice yields in these systems are presently only at about 40 to 60% of the climate-determined yield potential across agro-ecological zones. To increase agricultural productivity a holistic approach to technology development is needed. This process is called integrated rice management (IRM), which is based on agro-ecological principles and on holistic thinking with wide ranges of technological options that encompass the entire rice cropping cycle. In both irrigated and rainfed lowland systems key factors for raising productivity are soil fertility and weed management. Improved soil fertility and weed management in irrigated systems in Senegal are highly profitable; yields can be raised by 2 t ha⁻¹, closing the yield gap between actual and potential yield by 30%. In inland valley lowlands improving soil fertility and weed management also results in substantial yield increases, depending on water control. We compare approaches used to technology development in Sahelian irrigated systems and in inland valley systems in Côte d'Ivoire. We illustrate that the need for early farmer participation in technology development increases when moving from the relatively uniform high-precision Sahelian irrigated farming systems to the more diverse, low-precision inland valley lowland systems further south. Technologies need to be more flexible and less fine-tuned in the inland valley systems as compared to the Sahelian irrigated systems. More emphasis also needs to be placed on farmer innovations and adaptation according to the prevailing agro-ecological and socio-economic conditions rather than on technology prescriptions, and on farmer-experimentation. Scaling-out of results in the Sahelian irrigated systems was done through change agents of NGOs and national extension authorities and publicity campaigns. Scaling-out of results in the inland valleys relied on the establishment of rural knowledge centers and farmer-to-farmer training. R&D institutions have a much more facilitating role rather than a directing role, when comparing the irrigated Sahelian systems with the inland valley lowlands. In both systems, simple decision support tools, such as a cropping calendar can be extremely valuable to farmers. WARDA and IFDC have developed a participatory learning and action research (PLAR) curriculum for IRM in rice-based inland valley systems. Ultimately IRM needs to move to other aspects of integrated natural resources management (INRM) within a watershed or water basin that are relevant to stakeholders. However, the peoples-orientation, typical for PLAR, will be the leading principle, be it IRM or INRM.

Introduction

Rice (*Oryza sativa* L.) is developing as one of the major staple food crops in sub-Saharan Africa. Rice

production increased by about 2.4% year⁻¹ in the period 1990–2000, mainly due to an increase in cultivated area. Rice production in sub-Saharan Africa increased from 9.1 Mt in 1990 to 10.7 Mt in 2000,

with West Africa alone producing 6.9 Mt of rice in 2000 (Nguyen and Van Tran, 2002). Production was not sufficient to meet regional demand. Annual rice imports increased from 2.6 Mt in 1990 to 4 Mt in 2000, mainly to West Africa. Changing consumer preferences and higher consumption levels in urban centers are the main drivers behind this development (Defoer et al., 2003).

Only about 23 to 25 million tons, out of 600 million tons of milled rice produced world-wide, are traded on the world market, mainly from six countries: Thailand, Vietnam, US, India, Pakistan and China. Rapid urbanization and industrialization in Asia means increasing pressure on land and water resources, potentially leading to higher rice prices on the world market. The continued reliance of African consumers on rice imports is, therefore, a potentially precarious situation. Moreover, the cost of importing rice is a heavy burden on trade balances of African countries, with 1 billion US\$ spent on rice imports each year. Rice stocks are declining in Asian countries, and it is likely that China will be obliged to import rice in 2004, while it still exported 3 million tons of rice in 2003¹. Despite trade liberalization and devaluation of the Franc CFA in West African countries, rice remains competitive for most African countries, especially in land locked countries, such as Mali. There is a pressing need to develop production capacity for rice in the region and to improve the quality of domestically produced rice to meet consumer needs and to improve the competitiveness vis-à-vis imported rice.

The three main rice ecologies in West and Central Africa (WCA), found across agro-ecological zones, are the rainfed uplands, the rainfed lowlands, and the irrigated systems. The upland rainfed rice-based systems cover the largest area with 44%, mainly in coastal areas in the humid and sub-humid agro-ecological zone. The rainfed lowland systems are the second most important in terms of surface area with 31% of the total rice cultivated area. The third most important are the irrigated rice-based systems with 12% of the total rice cultivated area. Rainfed lowland systems provide 36% of the production, the irrigated systems account for 28%, followed by rainfed upland with 25% of the production.

Defoer et al. (2003) presented major biophysical and socio-economic constraints, opportunities and challenges related to rice production in the three main

ecologies. They point to the important potential for increased rice production in both the irrigated and rainfed lowland systems, and especially in the inland valley lowlands. Inland valleys are defined as flat-floored, relatively shallow valleys that are widespread in the African undulating landscape. They are known as *dambos* in eastern and central Africa, as *fadamas* in northern Nigeria and Chad, *bas-fonds* or *marigots* in francophone African countries and as inland valley swamps in Sierra Leone (Andriessie, 1986). Inland valleys are characterized by their upstream position relative to a hydrological network. In WCA alone, an estimated 20 to 40 million hectares of inland-valley swamps are found, of which only 10 to 25% is currently used (Windmeijer and Andriessie, 1994). Soils in the valley bottoms can be relatively fertile and may retain residual moisture well after an initial flooded rice crop, permitting two crops per year, or aqua-culture when base flow lasts enough. The hydro-morphic fringes and upland slopes and crests offer potentials for other food and cash crops, and for trees and livestock. Inland valleys constitute an important agricultural and hydrological asset at local and national level, and may provide an opportunity for sustainable agricultural development and thereby contribute to food security and poverty alleviation in sub-Saharan Africa.

In this paper we will present our experience with technology development for enhanced rice productivity in Sahelian irrigated systems and in inland valley lowlands. The transition between irrigated and rainfed lowland ecosystems is often quite fuzzy. A water-management continuum, ranging from strictly rainfed to fully irrigated lowland can be distinguished, which may evolve depending on investments in water control measures (Defoer et al., 2003).

We start this paper with a short description of the irrigated to rainfed lowland continuum in WCA. We then describe approaches used to participatory technology development by WARDA researchers and partners working on improving rice productivity and natural resources during the mid- to late 1990s in irrigated systems in the Sahel. Next, our experience with technology development and diffusion in inland valley systems is described. At first, this approach was building on the experience from the irrigated systems, but after one year of experimentation it was realized that a different approach was needed to respond to the diversity and dynamics of farmer reality in the inland valley systems. We developed a framework for participatory learning and innovation in inland valley systems with 60 farmers working in two neighboring sites in Côte d'Ivoire, one

¹Source: Jean-Pierre Boris, www.rfi.fr: 'La Chine affole le marché du riz'; 24 mars 2004.

with good and one with poor water control. The differences between the approaches used for technology development and diffusion in the irrigated and rainfed lowland systems are highlighted. Implications for actors, change agents and training institutions involved in agricultural research and development are discussed.

Irrigated to rainfed lowland continuum

Irrigated farming systems can be found throughout WCA, from the desert margins in Mauritania and Niger to the humid forest zone of Sierra Leone and Nigeria. Production systems vary widely between countries and agro-ecological zones. In the Sahel and Sudan savanna agro-ecological zones, water is either pumped from tube wells and major rivers or gravity-fed from rivers and dams. If rice is grown, the crop is either wet-seeded or transplanted and mainly grown during the wet season (July–November), with about 10 to 20% of farmers growing a second crop of rice on the same field during the dry season (February – May). Land preparation is usually done by animal power or tractor-driven. The first irrigated lands in the Sahel, situated in the Office du Niger in Mali (50,000ha) were established by the French colonial administration in the 1920s and thereafter. In the 1970s and 1980s, the World Bank and other donors funded new irrigation schemes, partly as a response to the severe droughts in the 1970s and rising concerns for food security. Such schemes were originally run by parastatal organizations, but with the reduced role of government, are now being turned over for management by farmer cooperatives. In addition to these large schemes, village irrigation schemes (< 20 ha) have been developed in the 1980s, while private initiatives (5–50ha) are common in for example the Senegal River Basin since 1990. New irrigation schemes are still being added, e.g. in Senegal, Mali and Burkina Faso.

Moving south into the Savanna and Humid Forest zones, schemes become smaller (5–200ha) and are mostly associated with inland valley systems. Irrigation schemes with good water control are generally found along major roads and near urban centers. Further away, simple bunding may be the only measure introduced by farmers to retain water on the fields. Water may be supplied from reservoirs and from streams where these have been diverted, while the original water course is used for drainage. Land is usually cultivated manually. If rice is grown, transplanting is the commonest form of crop establishment.

Participatory technology development for Sahelian irrigated systems

The approach taken for technology development in Sahelian irrigated systems is depicted in Figure 1. In the mid- to late 1990s, rice scientists from WARDA, Burkina Faso, Mali, Mauritania and Senegal established country-specific research and development (R&D) task forces to conduct combined agronomic and socio-economic yield gap surveys in key irrigated rice systems in the Sahel to determine reasons behind farmers' decision making and their major constraints and opportunities. These surveys were conducted in collaboration with farmer organizations, extension agencies,

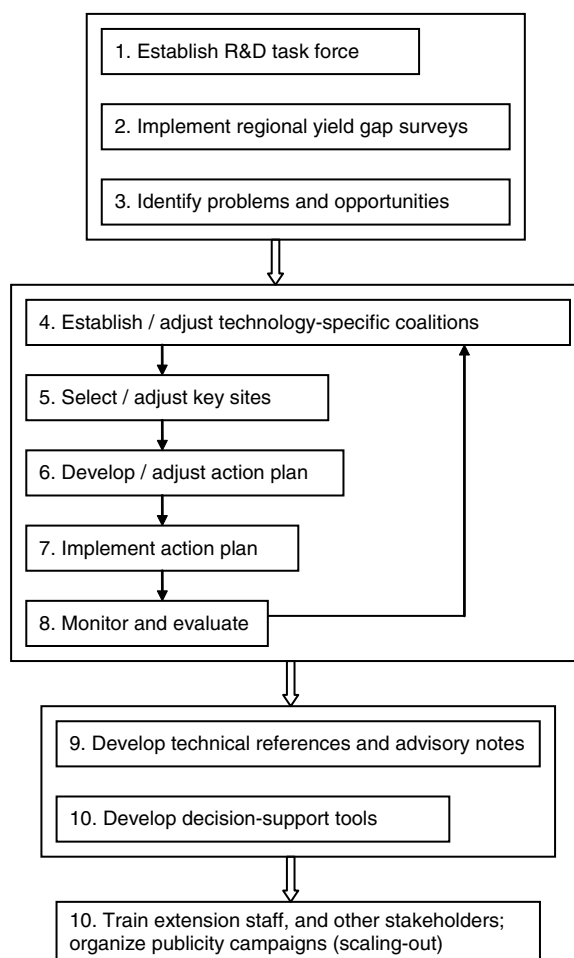

Figure 1. Framework for participatory technology development used in Sahelian irrigated systems

national agricultural research systems (NARS) and non-governmental organizations (NGOs). Technology-specific coalitions addressing the constraints and opportunities identified in the surveys were established, led by the agricultural research institutes. These coalitions resulted into a research action plan that was implemented at representative key sites with volunteer farmers. Results were then scaled-out through training of national extension and NGO staff or other stakeholders using promotion campaigns. The approach is illustrated below with results obtained mainly in irrigated rice systems along the Senegal River in Senegal.

Yield gap surveys

Wopereis et al. (1999) and Donovan et al. (1999) reported in detail on the yield gap surveys conducted in Senegal, Mali, Mauritania and Burkina Faso. Average farmers' yields varied between 3.8 and 7.2 t ha⁻¹, resulting in an overall average of 4.5 t ha⁻¹. Yields of individual farmers were highly variable, ranging from almost complete crop failure (0.3 t ha⁻¹) to very high yields (8.7 t ha⁻¹). High average yields and low yield variability were found in relatively old irrigation schemes, e.g. in the Office du Niger in Mali. Maximum yields reached by farmers were only at 40 to 60% of ten-year-averages of simulated potential yield (limited by climate only). The yield gap between average farmers' yields and highest farmers' yield was between 0.7 and 4.1 t ha⁻¹, with an average of 2.6 t ha⁻¹, indicating considerable scope to improve yields.

Only a few farmers in Mali and Burkina Faso applied organic fertilizer (compost, manure). Without exception, farmers applied N fertilizer, and most farmers also applied P fertilizer. K fertilizer use was mainly restricted to sites where NPK compound fertilizer use is recommended. N was always the most limiting nutrient for rice growth. Average N fertilizer recovery was relatively low and ranged from 18 to 50%, i.e. fertilizer N losses ranged from 50 to 82%. Farmers could, therefore, improve efficiency and profit by improving the recovery rate of N without major increases in investment in fertilizers. Reasons for the low N recovery rates were summarized by Wopereis et al. (1999) as follows: on all sites, timing of N fertilizer application by farmers was extremely variable and often did not coincide with critical growth stages of the rice plant. Farmers did not

take into account the soils' nutrient supplying capacity and on a number of sites compound NPK fertilizers were used, which were not specifically designed for rice. Other agronomic constraints included: use of relatively old (> 40 days) seedlings at transplanting (Kou Valley, Office du Niger), P and K deficiency (Office du Niger), unreliable irrigation water supply (Kou valley, dry season), delayed start of the wet growing season resulting in yield losses of up to 20% due to cold-induced spikelet sterility (Kou Valley, Senegal River Middle Valley, Office du Niger), weed problems (Senegal River Delta) and late harvesting (Senegal River Delta).

Haefele et al. (2000 and 2001) reported the following main agronomic constraints for irrigated systems in the Senegal River valley: (i) mismatches between timing of N fertilizer application and critical N demanding growth stages of the rice plant; (ii) non-use of P fertilizer on P deficient soils; (iii) largely neglected or inefficient weed management and (iv) late harvesting.

Participatory technology development

Based on the yield gap surveys, scientists from WARDA and the national research institute in Senegal (ISRA) developed new soil fertility and weed management strategies with emphasis on improved timing of urea application, the use of three instead of two nitrogen splits, application of P fertilizer and early and correct application of herbicides. With the Senegal River irrigation and extension authority (SAED), pilot farmers were identified in villages strategically located along the Senegal River. Over a period of two years, pilot farmers evaluated the new soil fertility and weed management recommendations on 'test plots', where farmers managed their own fields as usual, with the exception of soil fertility and weed management, which was carried out jointly by the SAED extension agent and the farmer. Meanwhile, to address the harvest and post-harvest problems, a thresher-cleaner and a stripper-harvester were imported from the Philippines and a consortium of research and development partners and small machinery manufacturers was formed to develop Senegalese prototypes of both machines (Donovan et al., 1998 and Wopereis et al., 1998). SAED extension staff organized regular field days to ensure that a maximum number of farmers profited from these developments, and organized promotion campaigns.

Results

Improved nutrient management (application of 20 kg P ha⁻¹ and 150 kg N ha⁻¹ in three splits at start tillering, panicle initiation and booting) increased yields by about 1 t ha⁻¹. Improved weed management (application of 6.0 l propanil ha⁻¹ and 2.0 l 2,4-D-amine ha⁻¹ at 2–3 leaf stage of weeds) also raised yields by about 1 t ha⁻¹ as compared to farmers' practice. The combined effect of improved nutrient and weed management was additive: improving both nutrient and weed management raised yields by almost 2 t ha⁻¹ over average farmers' yields of 3.9 t ha⁻¹, i.e. an increase of almost 50%. Value/cost ratios were between 2.1 and 4.6 for improved soil fertility and weed management resulting in an increase in net revenues of 40 to 85% compared to farmers' practice. The results of the learning plots were amazingly consistent and were obtained for both small-scale farmers in Senegal (Haefele et al., 2000) and large-scale farmers in Mauritania (Haefele et al., 2001). The yield increases obtained are considerably larger than obtained for similar work on site-specific nutrient management in intensive rice cropping systems in Asia (Dobermann et al., 2002).

The Senegalese version of the thresher-cleaner was baptized ASI and was officially released by the minister of agriculture of Senegal in 1997. The three institutions behind the development of the ASI (WARDA, SAED and ISRA) obtained the '*Grand Prix du Président de la République du Sénégal pour les Sciences*', out of the hands of President Wade in 2003 for the development and diffusion of the machine. Meanwhile, the project to develop a local version of the stripper-harvester was abandoned. During field tests farmers clearly indicated that they did not appreciate the fact that the machine left rice straw standing in the field.

Development of training materials and decision support tools

During farmer visits to test plots and field tests of the thresher-cleaner, various issues related to rice cropping were debated, including best age to transplant rice seedlings, control of pests and diseases, water management, access to fertilizers, credit, certified seed, etc. Gradually WARDA staff developed a powerful learning tool to facilitate these debates: a cropping calendar depicting timing of key management interventions (i.e.

sowing, transplanting, weeding, fertilizer application, harvesting) as a function of rice development stage (Wopereis et al., 2003). The cropping calendars can be easily adjusted to any choice of sowing date x site x cultivar combination along the Senegal River using the RIDEV decision-support tool (Dingkuhn, 1995; Wopereis et al., 2003).

Another direct consequence of the debates in farmers' fields was the development of a manual with technical references on irrigated rice cropping in the Senegal River valley (WARDA and SAED, 2000), as a support for research and extension staff.

Integrated rice management (IRM)

The outcome of the yield gap surveys, the encouraging results on the test plots and the stimulating debates in farmers' fields stimulated WARDA scientists to develop a set of *integrated rice management* (IRM) options that encompass the entire rice growth cycle, from the initial planning phase to the harvest and post-harvest stages (Table 1). IRM is based on agro-ecological principles and holistic thinking; new practices are complementary and not necessary alternatives to conventional management.

Capacity building and scaling-out

The results of the test plots were reported in meetings with ISRA and SAED and on rural radio. The IRM options listed in Table 1 were summarized on A4 leaflets and distributed to thousands of farmers in the Senegal River valley through SAED. Extension agents of SAED and local NGOs were trained in rice cropping and IRM in particular.

Agricultural machinery manufacturers from Senegal, Mauritania, Mali, Mauritania and the Gambia were trained in developing local prototypes of the thresher-cleaner to ensure scaling-out of the technology in the region. There are now hundreds of thresher-cleaners in West Africa, mainly in Senegal, Mauritania, Mali; all slightly different, depending on local settings, such as the need for animal traction.

An independent study by Kebbeh and Miézan (2003) confirmed the potential of IRM to raise rice productivity. They observed that technologies that are of greatest direct interest to farmers and that are within their reach are adopted first, such as improved soil fertility and weed management. Yield increases

Table 1. ICM options for the Senegal River Valley

1. Land preparation: cultivate on soil suitable for irrigated rice (i.e. heavy clay soils, local soil series terminology: Hollaldé and Faux-Hollaldé soils), make sure the field is properly tilled and leveled.
2. Varietal choice: use pre-germinated certified seeds; for the dry season (DS): Sahel108 (good grain quality, but salinity sensitive) or I Kong Pao (low grain quality, salinity tolerant); and for the wet season (WS): Sahel108, Jaya, Sahel201, Sahel202.
3. Sowing date: guided by RIDEV to avoid spikelet sterility due to cold or heat
4. Seeding rates: use certified seed and 100 and 40 kg/ha respectively for direct seeding and transplanting.
5. Maximum recommended fertilizer rates: 100 kg/ha Triple Super Phosphate (TSP, 20% P) or Diammonium Phosphate (DAP, 20% P, 18% N) and 250 to 300 kg/ha Urea (46% N), depending on location along the Senegal River. TSP is applied as a base fertilizer, while urea is applied in three splits. The first dose of 40% is applied at the start of tillering, and another dose of 40% at panicle initiation. A final dose of 20% is applied at the booting stage of the crop. Timing is guided by RIDEV.
6. Weed management: a mixture of 6 l/ha of Propanil and 1.5 l/ha of 2,4D applied a few days before first urea application (at 2-3 leaf stage of the weeds), complemented with one manual weeding before the second urea application.
7. Water management: directed at maximizing the efficiency of fertilizers and herbicides, consists of applying herbicides in completely drained fields and reducing water levels in the field to 3 cm for about 4-5 days at each fertilizer application. The rice field is completely drained 15 days after flowering to promote uniform ripening of the grains, but primarily to allow for a timely harvest (Dingkuhn and Le Gal, 1996).
8. Harvest and post-harvest: Harvesting at maturity, i.e. if about 80% of the panicles are yellow. Threshing within 7 days after timely harvest, preferably with the ASI thresher/cleaner prototype developed for Sahelian conditions by WARDA (Wopereis et al., 1998; Donovan et al., 1998).

were positively correlated to the number of IRM options farmers were able to adopt. Clampett (2001) obtained very similar results in irrigated rice systems in Australia.

Inland valley lowlands: yield gains from improved soil fertility and weed management under varying degrees of water control

Building on the experience from the irrigated systems, it was anticipated that soil fertility and weed management would be key factors in improving productivity in inland valleys as well. This hypothesis was tested in two valleys in central Côte d'Ivoire in collaboration with 32 farmers during the 2000 wet season and the 2001 dry season.

Site description

We worked in two inland valleys of varying water control with farmers from the villages of Bamoro and Lokakpli in the Bandama valley in central Côte d'Ivoire. These two villages are about 3km apart and located close to the main road from Bouaké to Katiola (5.04°W, 7.83° N). The Bamoro and Lokakpli inland valley lowlands are very different in terms of social cohesion and crop and water management.

Table 2 presents some of their major characteristics. Both sites are mainly managed by autochthon Baoulé, male-headed households.

In Bamoro, water is managed from the central stream, with some diverted canals, that inundate the fields and are also used to drain excess water. There is no infrastructure for irrigation and fields are partially banded to retain water. Severe flooding at the start of the wet season due to poor drainage is the major problem related to water management. Farmers can only grow rice during the rainy season. The majority of farmers prepare the land manually, while the rest do not cultivate the land before transplanting but simply cut the grass and leave it to decompose. Farmers in Bamoro do not use any fertilizer and hand weed. Harvesting is done manually and half of the farmers thresh rice mechanically.

In Lokakpli, irrigation and drainage facilities were constructed with funding from the Government of Japan in 1998. Irrigation is dam-based and by gravity with two lateral irrigation canals and one central drainage canal. All individual fields are banded and the risk of flooding is minimal. There are two rice growing seasons per year. Farmers use substantial amounts of mineral fertilizers (composite NPK as basal dressing and 1 or 2 top dressings of urea) and the majority of the farmers control weeds using herbicides. All rice is harvested manually and all farmers use mechanical rice threshers on a contract basis.

Table 2. Major characteristics of two inland valleys in Côte d'Ivoire

Characteristics	Bamoro site	Lokakpli site
Origin of farmers at the site (No. of villages)	1	3
Social cohesion	Strong	Weak
Age of household head	44 year	32 year
Dominant cropping systems (area in ha/percentage per farm household)		
- rice	0.34 ha / 39%	0.68 ha / 52%
- yams	0.51 ha / 57%	0.54 ha / 41%
- other	0.04 ha / 4%	0.06 ha / 7%
Water source	Flooding	Gravity irrigation
Irrigation infrastructure	None	Existing
Drainage	Poor	Good
Availability of bunds	Partial	Overall
Risk of flooding	High	Moderate
Rice crops/year	1	2
Land preparation	Manual (64%); None (36%)	Cultivator (100%)
Weeds control	Manual	Herbicides
Fertilizer use	None	NPK and urea
Threshing	Manual (47%) Mechanical (53%)	Mechanical (100%)

Source: Defoer et al. (2004b)

Experimental design

The study was conducted in the 2000 wet season (2000 WS: irrigated and rainfed site) and in the 2001 dry season (2001 DS: irrigated site only). The profitability of different fertilizer and weed management treatments was compared to farmers' practice, using partial budgeting techniques, and the net benefit of all treatments was estimated. More details are provided by Idinoba et al. (2004). For Lokakpli, alternative fertilizer management included reversing the local fertilizer recommendation (200 kg NPK, containing 18% N, 20% P₂O₅ and 20% K₂O and 100 kg urea ha⁻¹) to 200 kg urea and 100 kg NPK ha⁻¹ as it was anticipated that N was a much more limiting factor than P or K, given the results obtained in the irrigated systems. Alternative weed management consisted of an early herbicide application (propanil) at 20 days after transplanting (DAT). For Bamoro, alternative weed management consisted of an early hand weeding at 27 DAT, and alternative soil fertility management consisted of an application of 100 kg urea ha⁻¹ in two equal splits, at mid-tillering and panicle initiation of the rice crop.

Results

Yields obtained during the 2000 wet season in Bamoro and Lokakpli were strikingly similar. Farmers' practice resulted in about 4 t ha⁻¹. This is evidence that the soil fertility in Bamoro is much greater than in Lokakpli as these yields were obtained with mineral fertilizer in Lokakpli and without mineral fertilizers in Bamoro.

Yields during the 2001 dry season in Lokakpli were 0.7 to 0.9 t ha⁻¹ higher, because of more favourable weather conditions. Results of the trials are given in Table 3. At the rainfed site, alternative fertilizer management, consisting of an application of 100 kg urea ha⁻¹, resulted in a yield increase of 0.6 t ha⁻¹ over farmers' practice (no mineral fertilizer). Improved weed management (early hand weeding) increased grain yield only slightly, by 0.3 t ha⁻¹. At the irrigated site, alternative fertilizer management resulted in an average (2000 WS and 2000 DS) yield gain of 0.7 t ha⁻¹. Alternative weed management again only increased yield slightly, i.e. by an average 0.2 t ha⁻¹. The effect of combining the alternative soil fertility and weed management practices was more than additive, i.e. yield

Table 3. Rice grain yields in response to alternative soil fertility and weed management in irrigated and rainfed lowland inland valley systems in Central Côte d'Ivoire. FP: farmers' practice; T1: alternative soil fertility management; T2: alternative weed management; T3: alternative soil fertility and weed management.

Treatment	Irrigated lowland			Rainfed lowland	
	Yield (t ha ⁻¹)	Average (t ha ⁻¹)	S.E. (t ha ⁻¹)	Yield (t ha ⁻¹)	S.E. (t ha ⁻¹)
	2000	2001		2000	
FP	3.9	4.6	4.3	4.1	0.1
T1	4.7	5.3	5.0	4.7	0.15
T2	4.0	4.9	4.5	4.4	0.05
T3	5.2	6.1	5.7	5.1	0.3
Means	4.4	5.2		4.6	
S.E.	0.31	0.31		0.21	

gains of 1.0 t ha⁻¹ at the rainfed site, and an average of 1.4 t ha⁻¹ for the irrigated site. The value/cost ratios was 5.2 for the rainfed site and could not be calculated for the irrigated site as additional costs were negative as urea is cheaper than NPK fertilizer. Net revenues increased by an average of 25% (rainfed site) and 49% (irrigated site) as compared to farmers' practice. Results, therefore, confirmed the importance of soil fertility and weed management in both the irrigated and rainfed inland valley lowlands.

Moving methodologies to address diversity and dynamics in inland valleys

Although farmers in Bamoro were involved in the design of the experiments, they gradually started to question the use of 100 kg urea ha⁻¹, which they thought was excessive. They also pointed at the risk of fertilizer use, in case of floods as they have no control over water. During the cropping season, many other issues were discussed. We felt sometimes overwhelmed by the large and short-range variability in growing conditions among farmers, especially in Bamoro. Fields located side-by-side could differ in terms of soil type, water control (some experiencing flooding, others drought), problems with iron toxicity (mainly visible on fields near the hydromorphic fringe), and incidence of pests and diseases. There were also tremendous differences in sowing date, age of seedlings used for transplanting and weed control. Varietal choice was remarkably similar, with most farmers growing variety Bouaké189.

Reece et al. (2004) distinguish between low precision farming systems where farmers exercise relatively

little control and high precision systems where farmers exercise more control over their resources. Inland valley lowlands without any infrastructure to retain water or drain excess water such as in Bamoro do not allow precise farming, for example in terms of time of rice transplanting, and rice growth and development can be severely disrupted by drought or devastating floods. With increasing control over water and other resources more precise farming becomes possible.

We hypothesized that we could address the diversity and dynamics of farmers' reality in inland valley lowlands by (i) the analysis of common practices and knowledge, (ii) the introduction of new insights and options for improvement, (iii) the use of decision-support tools to assist farmers in making good observations, followed by analysis that motivate them to try out new ideas; and (iv) farmer-led innovation and adaptation of improvements. This approach would then gradually lead to a basket of decision-support tools and adapted IRM options for inland valley lowlands. We realized, however, that the degree of water control was a crucial factor for farmers, and we expected that IRM options likely to be innovated and adapted by farmers would greatly differ between Bamoro and Lokakpli. Another important factor, making some options more attractive than others, is access to factor and output markets. However, the two inland valleys did not differ in that respect, as they were both located within 3km distance along the Bouaké – Katiola road.

Our observations in Bamoro prompted us to adopt a much more innovative approach to social learning, called participatory learning and action research (PLAR). PLAR is a farmer education approach, based on adult learning in groups of 20 to 25 farmers, making

use of the experiences of the group members (Defoer and Budelman, 2000; Defoer et al., 2004a). PLAR for IRM is captured in a *curriculum* that covers the whole cropping season, following the development stages of the rice crop and the agricultural practices. Farmers analyze their own practices, discover problems and seek the solutions to solve them. Instead of diffusing or transferring the technologies coming from research/extension services, the facilitators incite farmers to find solutions themselves and help them to become better rice crop managers. PLAR seeks to find solutions that are practical, applicable, and adapted to local-specific situations.

In the PLAR approach, farmers are not considered as potential “recipients” or “adopters” of new technologies; the idea is to create a process which will stimulate the farmers into discovering and innovating themselves. The underlying assumption is that in a given context, the learning, discovering, innovating, adaptation-selection process prompts change and sustainable improvement of the production system. This learning process is facilitated by a team of facilitators, the PLAR-IRM team, often coming from extension services, research or NGOs.

A framework for participatory learning and action-research in inland valleys

Our experience in Bamoro and Lokapli led us to believe that much more emphasis should be put on farmer-led innovation. We also realized that to scale-up and –out our approaches and results we would need to involve local research and extension agencies to a much greater extent. There was also a need for training materials and relevant decision-tools to allow farmers and change agents to make better observations and analyses of problems and opportunities and improve decision-making. We developed a framework (Figure 2) for participatory learning and action research early 2001 and implemented the framework during the wet season of 2001 in both Bamoro and Lokapli. Key concerns were:

1. Involvement of farmers and change agents
2. Farmer innovation
3. Development of training materials to facilitate training of farmer trainers and facilitators to scale-out
4. Development of decision support tools to allow better observations, better analysis and improved decision-making

5. Build institutional capacity to scale-up the approach used within the facilitating research and extension institutions

Application of the PLAR-IRM framework

Establishing PLAR-IRM capacity and selection of key sites

In May 2002 we contacted the national extension agency in Côte d’Ivoire (ANADER) and discussed the PLAR framework with them. We agreed to establish a team of facilitators, consisting of ANADER and WARDA staff that would work at the Bamoro and Lokakpli keysites during one entire growing season. We then discussed the PLAR idea with farmers from Bamoro and Lokakpli. About 30 farmers volunteered to participate in each valley. In a first encounter with the farmers a list was made of problems and opportunities related to rice cropping in the two valleys. A first draft of an agenda was made with issues to be debated during the growing season. This agenda was adjusted as the growing season progressed. Farmers and the PLAR team agreed to meet every week for about 3 to 4 hours, i.e. one morning in Bamoro, under a large tree, near the valley bottom, and one morning in Lokakpli, in a small building near the irrigation scheme. These meeting places were referred to as PLAR-IRM centers. The PLAR team met weekly at the ANADER office in Bouaké to prepare the PLAR sessions and to evaluate progress.

Implementing PLAR-IRM

PLAR sessions usually started in the PLAR-IRM center, but almost always involved a visit to the field to make field observations. Field observations are crucial in the PLAR approach. Farmers are ‘learning’ together how to make good observations, followed by a sound analysis and decision-making. The types of observations that were made were first discussed during plenary sessions at the PLAR-IRM center.

Farmers were encouraged to put into practice any new idea they gained through the PLAR sessions on part of their fields (i.e. ‘IRM learning plots’). In Lokakpli, farmers tried out more than five new practices on average. In order of importance, farmers experimented with improved fertilizer management, weed control,

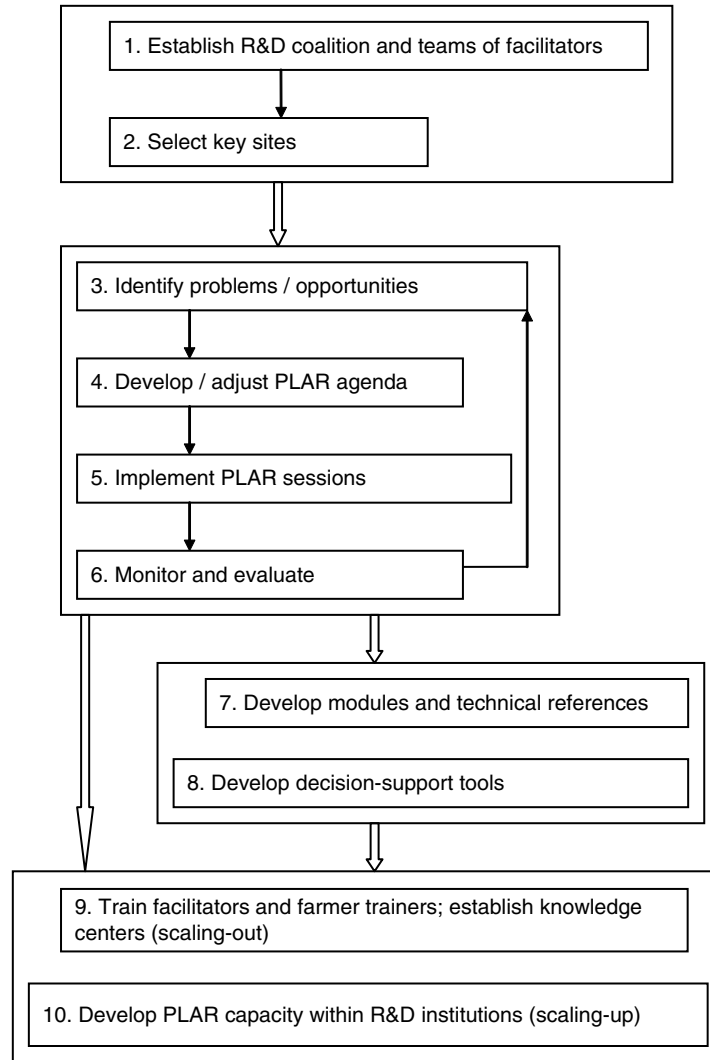

Figure 2. A framework for implementation of PLAR in inland valleys

water management, transplanting of seedlings, harvest management and bund maintenance. In Bamoro, the average number of new practices tried out by farmers was three. The order of importance of the new practices tested was different compared to Lokapli. Most important was improved transplanting and weed control, followed by improved nursery management, water management and bund maintenance. Improved fertilizer management and harvest management received less of farmers' attention than in Lokapli. More details are found in Defoer et al. (2004b). IRM options increased rice yields by an average of 0.6 t ha^{-1} in both inland valleys. This was, therefore, slightly lower than what was obtained in the researcher-led

controlled learning plots during the wet season in the previous year (see section 3).

Development of PLAR Modules

From May to November 2001, a PLAR curriculum composed of 28 learning modules was developed with farmers (Figure 3). Each learning module comprises an introduction, learning objectives, a procedure for implementation, time and materials required. The introduction presents the issue(s) treated in the module and the learning objectives generally relate to specific skills and capacities farmers are likely to acquire through

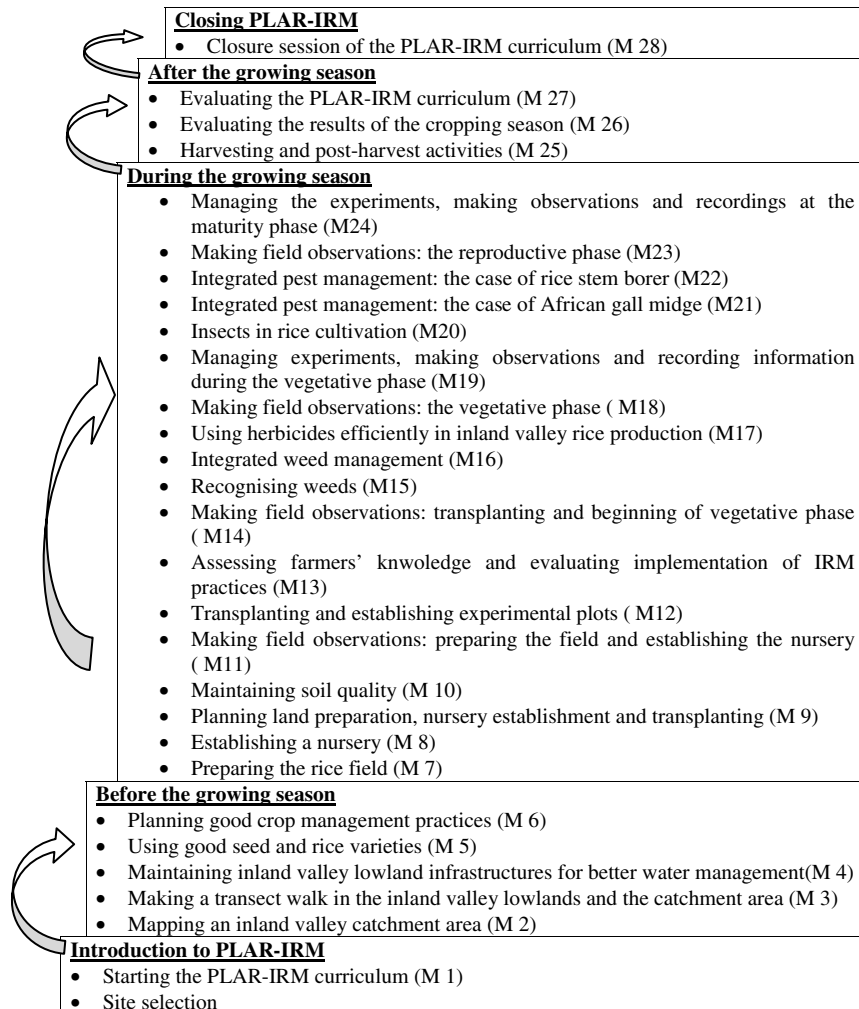

Figure 3. Modules of the PLAR curriculum

the implementation of the module. For most of the modules, the procedure for implementation includes: a short review of the previous module, presentation of the learning objectives, exchange of farmers' experiences, introduction of new ideas using learning tools, field observations in sub-groups, plenary session and evaluation of the module. The full set of learning modules is given by Defoer et al. (2004a).

Development of IRM technical references

During the same period, a list of technical references was developed, parallel with the development of the modules (Table 4). The references deal with agronomic issues related to rice cropping in inland valleys and

provide technical backstopping to change agents in the PLAR teams. The full set of technical references is given by Wopereis et al. (2004).

Decision support tools

A very important aspect of the PLAR sessions was the use of simple decision-support tools and the emphasis on agro-ecological and socio-economic principles. The most important decision-support tool was the cropping calendar, which was also used with success in the Sahelian irrigated systems. The cropping calendar was 'constructed' by the farmers themselves using pre-conceived symbols for rice development stage and management interventions depicted on small cards

Table 4. Technical references for inland valley development

1.	Selecting PLAR-IRM sites
2.	Hydrological network, inland valley catchments and lowlands
3.	Different types of soil
4.	Iron toxicity
5.	Water control structures for inland valley lowlands
6.	The seasonal work plan
7.	Field water management
8.	Knowing the rice plant
9.	Seed production
10.	Selecting a variety
11.	Effects of temperature on rice development
12.	Field preparation before the start of the rice growing season
13.	The seedling nursery
14.	Plant nutrients
15.	Integrated soil fertility management
16.	Transplanting
17.	Farmers' experimentation
18.	Getting acquainted with weeds of rice
19.	Integrated weed management
20.	Safe and correct use of herbicides
21.	Insects in rice cropping
22.	African rice gall midge
23.	Rice stem borers
24.	Major diseases in rice
25.	Integrated rice disease management
26.	Harvest and post-harvest
27.	End-of-season evaluation

which were fixed on a white cloth, below a time-line subdivided into weeks. The cropping calendar allowed farmers to obtain a global picture of all the development stages of the rice plant, assisting them in planning agricultural practices. Discussions around the cropping calendar allowed farmers to identify options to improve time-management, such as timely transplanting, fertilizer application or weeding. The improved time-management options were then visualized by depicting the cards with corresponding symbols on a line above the lines representing farmers' current management practices. Farmers then discussed necessary conditions to implement the improved time-management options.

Farmers also produced a large (about 3 x 1 m) map of the inland valley itself, highlighting different soil types, the extent of the lowland, hydromorphic zone, and upland areas, and drainage and irrigation infrastructure (in the case of Lokakpli). This map proved useful, especially in Bamoro, where the PLAR sessions and the map motivated farmers to work together for a period of 3 days to build a central drainage canal to improve water control in their valley lowlands. Other

decision support tools used where pictures of symptoms of diseases, life cycles of insect pests and nutrient deficiency symptoms.

A large amount of time was devoted to soils and soil fertility management. Farmers were keen to learn about simple decision-support tools to analyze soil texture and soil organic matter content. They realized the importance of these soil characteristics for the efficiency of mineral fertilizer use, especially after conducting percolation experiments with different soil types. Much time was devoted to improved understanding of the importance of the major nutrients to rice growth and development, and what nutrients are found in fertilizer bags and in what quantity. The use of 'nutrient-omission trials' was also discussed, where one nutrient is deliberately omitted, and others applied in sufficient quantities to evaluate to what extent the missing nutrient limits growth (e.g. Dobermann et al., 2002). The outcome of such trials may be used to develop site-specific soil fertility management options within the inland valley lowland area. This particular method is extremely powerful and very illustrative. Farmers debated access to organic and mineral fertilizers, their costs and potential benefits and financial returns from their (combined) use.

Particular attention was also paid to weed management. Farmers developed a herbarium of weeds occurring in the two valleys and ranked these in terms of competitiveness vis-à-vis the rice crop. Farmers were able to distinguish and name (using local nomenclature) more than 30 weed species in each valley and rank these in terms of competitiveness. Lokakpli farmers were using herbicides to control weeds, so in this village we paid attention to safe and correct use of herbicides, in terms of: (i) choice of product as related to weed flora in the field; (ii) timing of the treatment; (iii) water management; (iv) equipment inspection and maintenance; (v) calculation of dose to apply; (vi) application techniques and (vii) safety.

Calculating what dosage to apply is often a problem for rice-growers and for extension agents. We have tried to simplify calculations by using a measuring unit that is easy to find in most West African markets: the small tomato can, containing 50 to 60 ml of tomato paste. For a sprayer capacity of 15 liters per hectare and a normal application rate of 300 l ha⁻¹ a farmer needs to use x small tomato cans filled with herbicide per sprayer to apply x liters of herbicide per hectare. For example, to control grasses, it is recommended to apply 5 litre ha⁻¹ of a particular herbicide. This dosage corresponds to 5 small tomato cans of the herbicide per

15 liter sprayer. This particular simple and practical decision support tool was very much appreciated by farmers in Lokakpli. More details on these and many other decision-support tools can be found in Defoer et al. (2004a) and Wopereis et al. (2004).

Scaling-out: training of facilitators and farmer trainers

In 2002, 40 researchers, extension agents and NGOs from Benin, Burkina Faso, Côte d'Ivoire, Guinea, Mali, Togo and Senegal were trained at a workshop in the PLAR-IRM approach. Four farmers from Bamoro and Lokakpli also attended the workshop. In 2002 PLAR-IRM testing was extended to five additional sites in Côte d'Ivoire and new sites in Benin, Burkina Faso, Guinea, Mali and Togo.

Keysites need to gradually become veritable 'knowledge centers' on IRM. It is anticipated that some farmers in such IRM knowledge centers will train colleague farmers from neighboring valleys. In 2002, publicity tours were made to neighboring villages around Bamoro and Lokakpli to create awareness of the existence and competences of these two new rural knowledge centers. Four demands for training were received. Members of the PLAR-IRM team assisted four farmer trainers to prepare training sessions and provide on-the-job guidance during implementation. We compensated the farmer trainers using a system of 'learning-coupons' valued at CFA 2000 (about 3 euros) for one training session. After receiving training, a farmer group pays the farmer-trainer one learning-coupon who claims the value of the ticket from ANADER/WARDA. Such a system needs to be phased out gradually. This is, however, only one possibility of a reward system that requires further experimentation and adaptation. Experiences in 'knowledge centers' will provide valuable feedback to research. It will be important to determine the optimal density of 'knowledge centers' that an extension service can handle and that will allow for sufficient coverage of the inland-valley rice-based systems through farmer-to-farmer exchange and learning.

Scaling-up: building PLAR-IRM capacity

PLAR is often a relatively new approach for R&D change agents and for it to be accepted will need time and capacity building at all levels within the R&D organizations. R&D change agents play a facilitating role,

whereas they are often used to a much more directing role.

Conclusions

The classic scenario for technology transfer in agricultural research has been for researchers to develop technology on research stations. They then hand over a final product to extension agents for delivery to end-users. This 'assembly line' approach has been able to generate improved technologies, such as modern, high-yielding rice varieties, but adoption rates have often been disappointing.

For the Sahelian irrigated systems, which are relatively uniform and enjoy relatively high crop management precision, identification of constraints and opportunities was conducted at a regional level through a R&D task force. Technology-specific coalitions were then established, one for improved weed and soil fertility management and one for the development of appropriate agricultural machinery. These coalitions developed an action plan and worked with farmers and manufacturers to evaluate and adapt technologies at key sites, often through test plots, and regular field visits. Gradually a basket of IRM options was developed. The cropping calendar decision support tool was frequently used in farmer meetings to introduce the concept of IRM. Given the relatively uniformity of these conditions, scaling-out was done through training of extension staff and promotional campaigns, and relatively 'fixed' technologies were released.

For the inland valley lowlands, a peoples-oriented approach (in contrast with the technology-oriented approach in irrigated systems) was needed given the diversity and dynamics of farmer reality and growing conditions encountered in the field. A coalition of R&D organizations established teams of facilitators that worked in two inland valleys differing in terms of water control and social cohesion. In this approach, identification of constraints and opportunities was done at the village level and an action plan was elaborated with the farmers. PLAR sessions stimulated farmer-led innovation. Much emphasis was placed on observation skills and sound analysis to improve decision-making. PLAR sessions discussed all aspects of rice cultivation from land preparation to harvest and post-harvest issues. The team of facilitators brought in outside expertise whenever needed.

The two villages involved in the PLAR work eventually became knowledge centers on IRM, with farmers

training colleagues from neighboring villages. Scaling-out occurred in this approach through farmer-to-farmer training. Extension and research organizations played a facilitating rather than a directing role. This approach requires quite a shift in approaches currently used in R&D organizations in sub-Saharan Africa. We believe, however, that the need to use PLAR type (peoples oriented) approaches increases moving from high to low precision systems and from relatively uniform to more diverse production systems. Technology development can be more advanced in Sahelian irrigated systems before evaluation by farmers; farmers in inland valleys need flexible technologies that they can be adjust relatively easily to local settings.

Farmers in both low and high-precision systems can benefit tremendously from decision-support tools and improved knowledge of agro-ecological and socio-economic principles.

Our work resulted in a PLAR curriculum for IRM in inland valley lowlands. As inland valleys have large potential for diversification, the PLAR-IRM approach may be gradually extended to other crops and deal with diversification aspects of rice-based inland-valley systems. This direction is likely to be influenced by the precision of farming and 'logic for intensification', i.e. access to factor and output markets. Additional learning modules may be developed to extend the curriculum, including aspects of social organization and conflict management. Others may be irrelevant for certain settings or may need revision. We started with rice management given its importance in inland valleys, but IRM should be seen as an entry point to integrated natural resources management (INRM). Whatever the topic, PLAR with a strong peoples-orientation will be the leading principle. Already some modules in the curriculum pay attention to the interaction between the upland and lowland areas in an inland valley, and implications of changes in water management for downstream users.

Acknowledgements

This work was partly financed by the International Fund for Agricultural Development (IFAD).

References

Andriessse, W., 1986. Wetlands in sub-Saharan Africa: Area and distribution. In: Juo, A.S.R. and Lowe, J.A. (editors). The wetlands and

- rice in sub-Saharan Africa. Proceedings of an international conference on wetland utilization for rice production in sub-Saharan Africa, 4–8 November 1985, Ibadan, Nigeria. International Institute of Tropical Agriculture, PMB 5320, Ibadan, Nigeria, pp. 15–30.
- Clampett, W.S., 2001. Integrated crop management and technology transfer in the New South Wales rice industry: the Australian Ricecheck model. *FAO International Rice Commission Newsletter* 50: 7–17.
- Defoer, T., Wopereis, M.C.S., Idinoba, P. and Kadisha, T., 2004a. Curriculum d'apprentissage participatif et recherche action pour la gestion intégrée de la culture de riz de bas-fonds en Afrique sub-Saharienne: Manuel du facilitateur. *WARDA / IFDC / CTA* (English and French versions in press).
- Defoer, T., Wopereis, M.C.S., Idinoba, P. Kadisha, T., 2004b. Learning for change: rice management in inland valley lowlands. *Agriculture, Ecosystems and Environment* (submitted).
- Defoer, T., Wopereis, M.C.S., Jones, M.P., Lançon, F., Erenstein, O., 2003. Challenges, innovation and change: towards rice-based food security in sub-Saharan Africa. Paper presented at the 20th session of the International Rice Commission, FAO, Bangkok, 23–25 July 2002.
- Defoer, T., Budelman, A. (editors), 2000. *Managing soil fertility in the tropics: a resource guide for participatory learning and action research*. Amsterdam, the Netherlands, Royal Tropical Institute (KIT).
- Dingkuhn, M., P.Y. Le Gal, 1996. Effect of drainage date on yield and dry matter partitioning in irrigated rice. *Field Crops Research* 46: 117–126.
- Dingkuhn M., 1995. Climatic determinants of irrigated rice performance in the Sahel. III. Characterizing environments by simulating the crop's photothermal responses. *Agricultural Systems*, 48 : 435–456.
- Dobermann, A., Witt, C., Dawe, D., Gines, G.C., Nagarajan, R., Satawathananont, S., Son, T.T., Tan, P.S., Wang, G.H., Chien, N.V., Thoa, C.T.K., Phung, C.V., Stalin, P., Muthukrishnan, P., Ravi, V., Babu, M., Chatuporn, S., Kongchum, M., Sun, Q., Fu, R., Simbahan, G.C., Adviento, M.A.A., 2002. Site-specific nutrient management for intensive rice cropping systems in Asia. *Field Crops Research* 74: 37–66.
- Donovan, C., M.C.S. Wopereis, D. Guindo, B. Nèbié, 1999. Soil fertility management in irrigated rice systems in the Sahel and Savanna regions of West Africa. Part II. Profitability and risk analysis. *Field Crops Research* 61: 147–162.
- Donovan, C., K.M. Miézan, M.C.S. Wopereis, B.S. Diack, B. Douthwaite, 1998. Technology transfer from Asia to Africa sets the stage for public and private sector collaboration in new technology in Senegal. *IRRN* 23 (2): 41–42.
- Häfele, S., Wopereis, M.C.S., Donovan, C., Maubuisson, J., 2001. Improving productivity and profitability of irrigated rice production in Mauritania. *European Journal of Agronomy* 14 (3): 181–196.
- Häfele, S., Johnson, D.E., Diallo, S., Wopereis, M.C.S., Janin, I., 2000. Improved soil fertility and weed management is profitable for irrigated rice farmers in Sahelian Africa. *Field Crops Research* 66: 101–113.
- Idinoba, P.A., Wopereis, M.C.S., Erenstein, O., Kent, R., Johnson, D. Incremental yield and productivity gains from improved soil fertility and weed management under varying degrees of water control in inland valley lowlands in Côte d'Ivoire. *European Journal of Agronomy* (in preparation).

- Kebbeh M. & Miézan K.M., 2003. Ex-ante evaluation of integrated crop management options for irrigated rice production in the Senegal River Valley. *Field Crops Research*, 81: 87–94.
- Nguyen, V.N., and Tran, D.V., 2002. Issues and challenges of sustainable rice production for food security in sub-Saharan Africa. Working paper FAO, Rome.
- Reece, D., Sumberg, J. and Pommier, L., 2004. Matching technologies with potential end users: a knowledge engineering approach for agricultural research management. *Journal of Agricultural Economics* 55(1): 25–40.
- Windmeijer, P.N. and W. Andriesse (editors), 1994. Inland valleys in West Africa: an agro-ecological characterization of rice-growing environments. ILRI publication 52, Wageningen, the Netherlands.
- WARDA and SAED, 2000. Manuel pratique pour la riziculture irriguée dans la vallée du fleuve Sénégal. ADRAO, BP 96, St. Louis, Senegal, 80 pp. + annexes.
- Wopereis, M.C.S., Defoer, T., Idinoba, P., Dugué, M.J., Diack, S., 2004. Curriculum d'apprentissage participatif et recherche action pour la gestion intégrée de la culture de riz de bas-fonds en Afrique sub-Saharienne: Manuel technique. WARDA/IFDC/CTA (English and French versions in press).
- Wopereis, M.C.S., Haeefe, S.M., Dingkuhn, M., Sow, A., 2003. Decision support tools for irrigated rice-based systems in the Sahel. In: Struif-Bontkes, T.E. and Wopereis, M.C.S. (editors). Decision support tools for smallholder agriculture in sub-Saharan Africa: A practical guide. IFDC (An International Center for Soil Fertility and Agricultural Development), P.O. Box 2040 Muscle Shoals, Alabama 45662, USA and ACP-EU Technical Centre for Agricultural and Rural Cooperation (CTA), Postbus 380, 6700 AJ Wageningen, The Netherlands, pp. 114–126.
- Wopereis, M.C.S., C. Donovan, B. Nebié, D. Guindo, M.K. N'Diaye, 1999. Soil fertility management in irrigated rice systems in the Sahel and Savanna regions of West Africa. Part I. Agronomic analysis. *Field Crops Research* 61: 125–145.
- Wopereis, M.C.S., K.M. Miézan, C. Donovan, A.M. Ndiaye, B. Douthwaite, 1998. A new Senegalese Thresher / Cleaner responds to small-farmer post-harvest needs. *IRRN* 23 (2): 39–41.