

NEW AGE

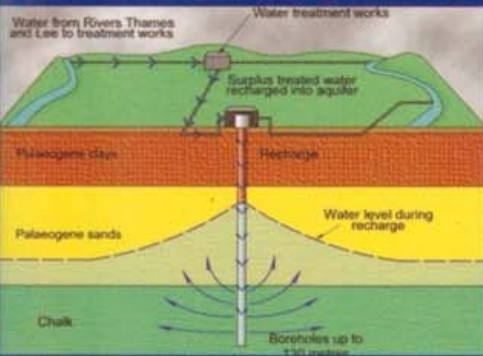

# WATER MANAGEMENT

## Conservation, Harvesting and Artificial Recharge

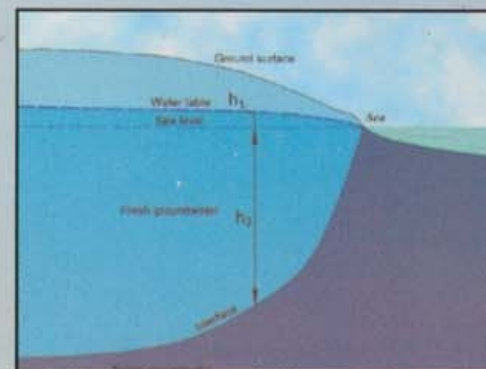

**Dr. A.S. Patel**  
**Dr. D.L. Shah**



NEW AGE INTERNATIONAL PUBLISHERS

# **WATER MANAGEMENT**

**This page  
intentionally left  
blank**

# **WATER MANAGEMENT**

**Conservation, Harvesting and  
Artificial Recharge**

**A.S. Patel**

Head & Professor  
Civil Engineering Department

**D.L. Shah**

Professor  
Applied Mechanics Department  
**Faculty of Technology and Engineering  
M.S. University of Baroda  
Gujarat**



PUBLISHING FOR ONE WORLD

**NEW AGE INTERNATIONAL (P) LIMITED, PUBLISHERS**

New Delhi • Bangalore • Chennai • Cochin • Guwahati • Hyderabad  
Jalandhar • Kolkata • Lucknow • Mumbai • Ranchi

Visit us at [www.newagepublishers.com](http://www.newagepublishers.com)

Copyright © 2008, New Age International (P) Ltd., Publishers  
Published by New Age International (P) Ltd., Publishers

---

All rights reserved.

No part of this ebook may be reproduced in any form, by photostat, microfilm, xerography, or any other means, or incorporated into any information retrieval system, electronic or mechanical, without the written permission of the publisher.  
*All inquiries should be emailed to [rights@newagepublishers.com](mailto:rights@newagepublishers.com)*

**ISBN (13) : 978-81-224-2632-8**

**PUBLISHING FOR ONE WORLD**

**NEW AGE INTERNATIONAL (P) LIMITED, PUBLISHERS**

4835/24, Ansari Road, Daryaganj, New Delhi - 110002

Visit us at [www.newagepublishers.com](http://www.newagepublishers.com)

# **P**REFACE

---

Increase in population and change in lifestyle has created water scarcity in many parts of the world. Microstructures for rain water harvesting, artificial recharge and reuse of water are becoming more and more popular to solve the local water problems, to mitigate water shortage and improve water quality. In this book, it is attempted to fill the big gap between monitoring and performance of actual constructed structures and theoretical design in the literature. The three main structures for artificial recharge of groundwater viz. check dam, percolation tank and aquifer storage recovery well, are evaluated in this book. Topics related to reuse of water and artificial rain are also discussed in length which will be necessary in the coming period. India has a very long coastal area, so sea water intrusion and preventive structures are very important. This topic is also included in this book. Both the rationalized and empirical approaches found valuable have been discussed. Many Case Studies will help the field workers to adopt optimum design of micro-structures.

For the last several years, the authors have been associated actively with research and teaching of the subject at the undergraduate and postgraduate level. So this book will be very much useful for the students of water management subject at the undergraduate and postgraduate level. It will be also very much useful to the practising engineers, farmers and policy makers.

The authors express their sincere thanks to V. P. Parekh and Manmohan Singh for their kind help. Thanks are also due to Mrs. Prafulla Patel and Mrs. Chetna Shah who provided continuous encouragement for this project from its inception. Special thanks are due to Mr. Saurabh Patel for his help in composing the manuscript.

*Authors*

**This page  
intentionally left  
blank**



Narmada, Water Resources,  
Water Supply & Kalpasar Department  
Government of Gujarat  
Block No. 8, 7th Floor,  
New Sachivalaya,  
Gandhinagar - 382 010.  
Gujarat, India.  
Ph. : 23252233, 23252235  
Fax : 91-79-23252233  
E-mail : cc-nwrs@gujarat.gov.in

**Date: 09/04/2007**

## **F**OREWORD

---

On most of the river of the world, big dams are constructed. Very few sites are left for constructing big water storage structures. Irregular rainfall, limited rainy days has created flood and drought situation. Microstructure becomes more and more popular to solve the local problems, to mitigate the flood and to fight against draught. Increase population and change in life style have increase water demand. In this situation study, analysis and design of water conservation, rainwater harvesting, reuse of water, and artificial recharge of ground water with the demand of time.

Groundwater being a handy resource exploited heavily and due to this reason day by day groundwater table depleted and deterioration of groundwater quality is noticed in many parts of the world. Existing scarcity and water quality problems experienced practically all over the world make water harvesting a critical issue for sustainable development. India has a rich repertoire of traditional techniques for water harvesting and it is appropriate that these practices be evaluated and can be adopted through out the world wherever required. Many case studies given in this book will help readers and policy-makers to select specific optimum techniques.

Water Management - harvesting, conservation and artificial recharge by Dr. A.S. Patel and Dr. D. L. Shah is indeed a worthy contribution to the field of water management, in general and to the education of in this field in particular. Several features make this book remarkable among others concerned with this topic.

This book consist of various chapters such as hydrological cycle groundwater occurrence, water losses and its prevention, water conservation, rainwater harvesting, artificial recharge methods, their analysis and design. Many case studies of artificial recharge and rainwater harvesting are included in this book. Some of the case studies are fully analyzed to adopt such methods in similar situation throughout the world. Sea water intrusion is a common phenomenon on the coastal belt. So, a special chapter on this topic describes causes, concept, phenomenon, analysis, monitoring and structures needed for its prevention. Reuse of water will be required at the large extent in the coming days. So, concept of reuse of water, categories of waste water, technological innovations in the field, its reuse in different field, and case



studies. The world becomes very small. Most of the countries export and import some commodities. To produce their commodity, water consumed in the virtual water net export or import of water (in kinds of commodity) will create a water problem. From this point of view a concept of virtual water is also included. This chapter will guide the policy makers and farmers to prepare water footprint of the country and the change in agriculture cropping pattern depending upon the meteorological condition of the country. Artificial rain, reverse osmosis, moisture harvesting from the air in desert area and desalination is also included in this book.

On the whole, the book is well written, self contained and several aspects a unique contribution to the field of Water Management in general and water harvesting, conservation and artificial recharge in particular. I fully intend to recommend it to students, researchers, and consultants.

**(M.S. Patel)**  
*Secretary (K)*

# **C**ONTENTS

---

<i>Foreword</i>	(v)
<i>Preface</i>	(vii)
<b>1. INTRODUCTION</b>	<b>1</b>
1.1 Overview	1
1.2 Increasing Resource Demand	2
1.3 Floods and Droughts	4
1.4 Water Quality Management	6
1.5 Fresh Water Management	7
1.6 Wastewater Management	8
1.7 Recycling and Reuse of Water	8
1.8 Need for Technology Development	9
1.9 Water Conservation	10
1.10 Need of Ensuring Quality & Cost-effectiveness of Water Harvesting	12
1.11 Development of International River Basins	12
<b>2. HYDROLOGICAL CYCLE</b>	<b>15</b>
2.1 Introduction	15
2.2 Atmospheric Water	18
2.3 Precipitation	19
2.4 Surface Water	19
2.5 Infiltration	20
2.6 Groundwater	20
2.7 Evapo-transpiration	22
2.8 Recharge	23
<b>3. GROUNDWATER OCCURRENCE</b>	<b>25</b>
3.1 Introduction	25
3.2 Groundwater Occurrence	25
3.3 Source of Groundwater	26
3.4 Factors Controlling Groundwater	27
3.5 Water Bearing Properties of Soils and Rocks	27

**x** Water Management

3.6	Types of Aquifers	30
3.7	Aquifer's Lithology	32
3.8	Groundwater Flow	34
3.9	Groundwater Appearing on Surface	35
3.10	Groundwater Exploration	37
3.11	Aquifer Performance Test	39
<b>4.</b>	<b>WATER LOSSES</b>	<b>41</b>
4.1	Introduction	41
4.2	Evaporation	41
4.3	Transpiration	53
4.4	Interception	61
4.5	Depression Storage	63
4.6	Infiltration	63
<b>5.</b>	<b>WATER CONSERVATION</b>	<b>77</b>
5.1	Introduction	77
5.2	Development of New Supplies	77
5.3	Reducing Demand of Water	78
5.4	Evaporation Control	79
5.5	Equipments	84
5.6	Studies on Evaporation Control	85
5.7	Conservation of Soil Moisture	88
5.8	Soil Mulches	89
5.9	Influence of Farmyard Manure on Soil Moisture	90
<b>6.</b>	<b>RAIN WATER HARVESTING</b>	<b>93</b>
6.1	Introduction	93
6.2	Rain Water Harvesting	94
6.3	Roof Water Harvesting (RWH)	95
6.4	Water Harvesting by Ponds	106
6.5	Water Quality Consideration	108
<b>7.</b>	<b>ARTIFICIAL RECHARGE METHODS</b>	<b>111</b>
7.1	Introduction	111
7.2	Natural Recharge Measurements in India	111
7.3	Concept of Artificial Recharge	112
7.4	Methods of Artificial Recharge	112
7.5	Theory of Artificial Recharge by Spreading	116
7.6	Check Dam	122
7.7	Percolation Tank	122
7.8	Classification of Tanks	124

7.9	Flooding Methods	133
7.10	Indirect Methods	139
7.11	Methods of Artificial Recharge Practiced by People in Drought Prone Area	144
7.12	Well Clogging Mechanism and their Prevention	153
7.13	Cleaning of Injection Wells	162
<b>8.</b>	<b>CASE STUDIES</b>	<b>167</b>
8.1	In Situ Water Harvesting for Drinking Water Supply at Cherrapunji, Meghalaya	167
8.2	Case Studies of Artificial Recharge	168
8.3	Artificial Recharge — Siphon Recharge Experiment (National Geophysical Research Institute)	175
8.4	Water Quality Improvement by Artificial Recharge — Kanha Project, Vadodara	188
<b>9.</b>	<b>PERFORMANCE INDICATORS OF ARTIFICIAL RECHARGE STRUCTURES</b>	<b>195</b>
9.1	Introduction	195
9.2	Methodology Adopted	197
9.3	Percolation Tanks	197
9.4	Check Dams	205
9.5	Aquifer Storage Recovery (A.S.R.) Wells	212
<b>10.</b>	<b>SEA WATER INTRUSIONS</b>	<b>221</b>
10.1	Introduction	221
10.2	Causes of Sea Water Intrusion	223
10.3	Chemical Characteristics of Saline Water	224
10.4	Concept of Fresh-saline Interface	226
10.5	Phenomenon of Zone of Dispersion	227
10.6	Analytical Formulae for the Fresh – Saline Interface	230
10.7	Upconing of Saline Groundwater	237
10.8	Effect of a Relative Sea Level Rise	238
10.9	Control of Salt Water Intrusion	240
10.10	Countermeasures to Control Salt Water Intrusion	241
10.11	Monitoring of Salt Water Intrusion	244
10.12	An Overview of Salt Water Intrusion Along Gujarat Coast, India	245
10.13	Recharge Techniques	248
10.14	Salinity Control Structures	249
10.15	Coastal Land Reclamation	251
<b>11.</b>	<b>REUSE OF WATER</b>	<b>253</b>
11.1	Introduction	253
11.2	Concept of Reuse of Water	255
11.3	Categories of Wastewater Reuse	258

11.4	Technological Innovations	261
11.5	Types of Wastewater Reuse	263
<b>12.</b>	<b>VIRTUAL WATER</b>	<b>277</b>
12.1	Introduction	277
12.2	The Concepts of Water Footprint and Virtual Water	277
12.3	Definitions	278
12.4	Underlying Assumptions	280
12.5	Population - Food - Trade Nexus	280
12.6	Strategic Issues	282
12.7	The Economics of Water Use	284
12.8	Virtual Water Trade	285
12.9	Method for Calculating Amount of Virtual Water	285
12.10	Calculation of a Nation's 'Water Footprint'	288
12.11	Data Sources	289
12.12	Specific Water Demand Per Crop Type Per Country	291
12.13	Global Trade in Virtual Water	291
<b>13.</b>	<b>CREATION OF SWEET WATER</b>	<b>299</b>
13.1	Artificial Rain	299
13.2	Reverse Osmosis	303
13.3	R.O. Plant at Thermal Power Station	308
13.4	Low Temperature Thermal Desalination (LTTD) Plant	315
13.5	Affordable Desalination	317
13.6	Net is Used to Captive Water	318
	<b>REFERENCES</b>	<b>319</b>
	<b>INDEX</b>	<b>329</b>

# 1

# INTRODUCTION

## 1.1 OVERVIEW

The earth's population is projected to double from the present 5.6 billion to about 10 billion by the year 2050 (State of World Population Report, 1993, U.N. Population Fund). Most of this increase will occur in the Third World; where close to 90% of the world population will then live. Also, people will continue to migrate from rural areas to cities and already by the end of this century, there will be 22 mega cities (population more than 10 million), 18 of which will be in the Third World. Such cities have mega water needs, produce mega sewage flows, and will have mega problems. Already now, it is estimated that half the people in the Third World have no access to safe drinking water, that one billion get sick every year from waterborne diseases, and that 12 million die, 80% of which are children. Also, more water will be needed for irrigation of crops to provide enough food for the expanding population. Competition for water will become increasingly intense and can lead to unrest and war if not properly resolved.

Populations in industrialized countries will remain rather stable, except perhaps in the U.S. where the population may double in the next century, depending on immigration policies. However, increasing environmental concerns in First World countries will increase water *demands for stream benefits*, wetlands and other natural water areas, and recreation. This often leads to conflicts and polarization between interest groups, as for example, in the western U. S. where the issues are fish culture vs. farming, fish vs. hydropower, river beaches cultural vs. hydropower, and others.

Increasing water demands require more storage of water in times of water surplus for use in times of water need. Traditionally, this has been achieved by constructing dams. However, dams have finite lives because of eventual structural failure and sediment deposits in the reservoir. Also, good dam sites are becoming increasingly scarce, dams are not possible in flat areas, and they lose water by evaporation and can have adverse environmental and socio-economic effects. If water cannot be stored above ground by constructing dams, it must be stored below ground, via enhanced or artificial recharge of groundwater.

Integrated water management is most vital for poverty reduction, environmental sustenance and sustainable economic development in world because water has the potential for both disease causation and prevention. Availability of water in any parts of the world is under

tremendous stress due to growing population, rapid urbanization, increase in per capita consumption, industrial growth and other demands for maintaining ecology. It is to be stressed that nondevelopment of water storage projects is not a viable or available option in India, due to the large temporal variations in the river flows in Indian monsoonic climate. Tremendous progress has been made in the field of water resources development and management and consequent boost in agricultural production leading to self-reliance, rapid industrialization and economic growth. In spite of that, a large portion of population still lives in sub-standard conditions, devoid of even minimum civic amenities. Vast area under agriculture still depends on the mercy of monsoon. The pressures on our water and land resources are continuously increasing with rise in population and urbanization. All this demands sustainable development and efficient management of available water resources.

### 1.2 INCREASING RESOURCE DEMAND

Since independence, India has witnessed an unprecedented increase in population. From a population of about 343 million in 1947, the population has grown at a rate of 2.04% to cross the 1,000 million mark in 2000 (Fig. 1.1). With an increasing number of mouths to feed, there has

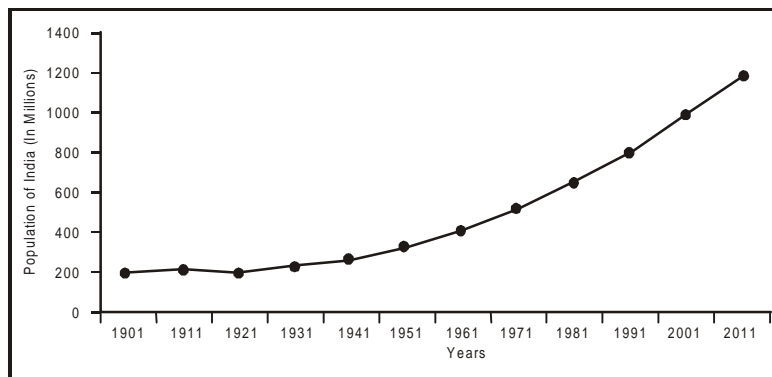

Fig. 1.1 Population of India 1901 – 2011(source: Census of India 1991).

been an additional pressure on agriculture resulting in an increase in net sown area from 119 million hectares in 1951 to 142 million hectares in 1997; high cropping intensity has also resulted in an increased demand for water resources. Domestic water need in the urban areas has also grown notably with the current urban population at 4.5 times the population level in 1950s (UNEP 1998). The water requirement of the manufacturing sector has increased in proportion to the increase in the sector's share in GDP from about 12% in 1950s to 20% in 1990s. By the year 2050, the population is expected to reach around 160 crores, the per capita availability will drastically reduced and our country shall be water stressed in many river basins. In planning critical resources like water we need to plan on safer side. A close watch on an increase in population is essential. The following Table 1.1 shows probable water availability against year.

Further, there is substantial variance in the different user sectors—agriculture, domestic and industry, vis-à-vis their share of water demand, resource pricing structure and usage efficiencies, which creates inter-sector competitions and conflicts. The agriculture sector, for instance, accounts for about 95% of the total water demand with the subsidized and free

**Table 1.1 Water availability**

<i>Year</i>	<i>Water availability (Kilo Litre per year per capita)</i>
1000	70,000
1850	10,000
1950	5,177
2000	1,820
2025	1,400 – likely population 130 crores
2050	1,140 – likely population 160 crores

regime of supply of power and water resulting in the over-exploitation and inefficient usage of water. The high resource cost for industries, on the other hand, cross-subsidizes the water consumed by the other sectors.

The demand for fresh water has been identified, as the quantity of water required to be supplied for specific use and includes consumptive as well as necessary non-consumptive water requirements for the user sector. The total water withdrawal/utilization for all uses in 1990 was about 518 BCM or 609m<sup>3</sup>/capita/year. Estimates for total national level water requirements, through an iterative and building block approach, have been made for the year 2010, 2025, and 2050 (Table 1.2) based on a 4.5% growth in expenditure and median variant population projections of the United Nations. The country's total water requirement by the year 2050 will become 1,422 BCM, which will be much in excess of the total utilizable average water resources of 1,086 BCM. At the national level, it would be a very difficult task to increase the availability of water for use from the 1990 level of approximately 520 BCM to the desired level of 1,422 BCM by the year 2050 as most of the underdeveloped utilizable water resources are concentrated in a few river basins such as the Brahmaputra, Ganga, Godavari, and Mahanadi.

**Table 1.2 Water requirements for different uses (in BCM)**

<i>Category</i>	<i>2010</i>	<i>2025</i>	<i>2050</i>
Irrigation	536	688	1008
Domestic	41.6	52	67
Industries	37	67	81
Energy	4.4	13	40
Inland Navigation	-	4	7
Flood Control	-	-	-
Afforestation	33	67	134
Ecology	5	10	20
Evaporation	36	42	65
Total	693	942	1422

(Source: National Commission for Integrated Water Resources Development Plan, 1999)



### 1.3 FLOODS AND DROUGHTS

**Causes of Floods:** Flooding caused due to several factors.

#### *Natural*

- Huge flows generated from rainfall occurring in a short span of time in the upstream catchments and consequent over bank spilling of the main rivers;
- Runoff generated by heavy local precipitation that can not drain out due to high stage in the out fall rivers;
- Landslide and glacial lake outbursts that result in high sediment deposition in the river course;
- High tide in the Bay of Bengal coupled with wind setup caused by South Westerly monsoon winds that obstruct drainage of the upland discharge, and
- Synchronization of the peak flows of the major rivers.

#### *Man Made*

- Deforestation in the upper catchments;
- Uncoordinated development activities in the upper riparian countries and in Bangladesh.

#### **Floods in South Asia**

**Nepal:** The major floods experienced in the Himalaya and the mountains are mainly due to glacier lake outburst or cloud burst and land slides. The three major rivers, the Sapt Kosi, the Gandaki and the Karnali originate in the Himalaya are snow and glacier fed. A large part of the drainage area is covered by snow and glacier throughout the year and play a significant role in the hydrologic regime of the river system. These rivers receive monsoon floods from June to September where about 85 percent of total precipitation falls.

**India:** All most all the rivers in India carry heavy runoff during monsoon due to intensive and heavy rainfall in their catchments. Flood problem in the Ganges basin in India are of three types inundation due to over bank spilling, erosion of riverbanks and changing river courses. In the Brahmaputra basin, a number of factors cause serious floods due to physiographic condition, meteorological situations, earthquakes, landslides and encroachment of river areas. Monsoon floods generally occur between June to September.

After the earthquake of 1950, the regime of the Brahmaputra river in the upper catchments in India changed considerably and the depth, duration and flooded area increased. Floods in India during 1954, 1962, 1966, 1972, 1973, 1974, 1983, 1984, 1987 and 1988 were very severe. The average area affected by flood in India is 7.9 million ha of which 3.69 million ha is cropped. On an average 1.25 million houses get damaged, over 1,00,000 cattle perish and about 1,500 human lives are lost. The estimated average annual loss in India is about us \$ 500 million.

**Bangladesh:** Flooding in Bangladesh is a recurrent phenomenon. About 60 percent of the country is flood prone, while about 25 percent of the land is inundated during monsoon in a normal year. Bangladesh experienced severe floods in 1954, 1955, 1961, 1962, 1964, 1970, 1971, 1974, 1984, 1987, 1988 and 1993. Bangladesh through its intricate network of river system drains catchments of about 1.75 million sq. km. Owing to the geographical location about 90 percent of the streams flow with high sediment load from upstream catchments which passes through Bangladesh.

Flood problem in the Ganges area in Bangladesh is mainly due to over bank spilling. The flood situation deteriorates when Brahmaputra remains in spate forcing backwater into the Ganges. The water in the Ganges begins to rise in May and period of maximum flood is in July and August. Occasionally September could be a month of severe flooding.

Flooding in the Brahmaputra is characterized by large-scale inundation of its banks, erosion at various places, and conveyance of heavy silt load from upstream. In Bangladesh, the area prone to flooding is 6.14 million ha which 42 per cent of total area of the country. The loss caused by floods in a normal year is about US \$ 175 million. In extreme situation, it may exceed US \$ 1 billion.

River basin development is a tool for social development. It supports economic growth and improves living conditions and the quality of life. The Ganges, the Brahmaputra and the Meghna are international rivers with its basin areas spread over China, Nepal, Bhutan, India and Bangladesh. Its peculiar geographical location has given the rivers ample water resources; but today no coordinated attempt has been made to utilize these. Piecemeal attempts for development in individual countries have not been effective in solving the problems of flooding.

Presently each country has its own plans and programs for developments, including flood control. But recent flood and other natural disasters have shown that such individual efforts are not enough within the country.

The need for holistic development and management of the river basins are needed to overcome the adverse effects of floods and maximize crop production with judicious use of water.

The construction of high dams in Nepal, Bhutan and India will generate not only cheap hydropower needed for overall development but also augment the dry season flows and mitigation of floods all the countries for the benefit of the people.

### ***Management of Floods and Droughts***

Floods and droughts though are natural calamities, these needs to be effectively managed, in order to mitigate their adverse impact on humans and animals. It is estimated that around 263 million people live in drought prone area of about 108 m. ha., which works out 1/3rd of the total Indian geographical area. Thus, more than 26% of total population of the country faces the consequences of recurring droughts, on a wide spectrum of social concerns. During the drought years, there is a marked tendency of intensive exploitation of groundwater, resulting in abnormal lowering of ground water table thus accentuating the distress. Grave adverse impacts are borne by flora, fauna and domestic cattle and the very life itself fights against nature for its survival. Droughts accentuate problems in cities in the form of mushrooming of slums and pressure on the existing civil amenities thereby adversely affecting urban life.

Over 40 million hectares of the area of the country (about 1/8th of total geographical area) experiences periodic floods. The average area affected by floods annually in India is about 7.5 m. ha. due to which crop area affected is 3.5 m. ha. Floods have claimed on an average 1529 human lives and 94000 cattles every year. Apart from loss of life and domestic property, the devastating effects of floods, sense of insecurity and fear in the minds of people living in the

flood plains is enormous. The after effects of floods like the agony of survivors, spread of epidemics, non-availability of essential commodities and medicines and loss of their dwellings make floods most feared natural disaster being faced by human kind. Large-scale damages to forests, crops & precious plants and deaths of aquatic and wildlife, migratory and native birds in various National Parks, Delta region, low altitude hilly areas and alluvial flood plains have always been the matter of serious concern. River Valley Projects moderate the magnitudes as well as frequencies of floods.

Floods and drought management, therefore, form an important part of overall water resources development and management. Water of potable quality is essential for sustenance of life.

Besides, water is required for other domestic use and for livestock. This requirement of water though not very large, has to be met at a huge cost due to strict quality parameters and long conveyance. Norms of water supply in Indian cities are more than in some of the developed countries of Europe. Users need to realize value of treated water and should inculcate habit of conservation. The existing system should be maintained and leakage prevented to the extent possible. Lavish consumers should be charged heavily and pricing of water should be used as a tool for demand management. Low cost technique for recycling and reuse of grey water (Bath room and kitchen wash) and black water (Sewerage) should be developed and encouraged. Water requirement for industries, at present is not significant. However, with continuous urbanization and industrialization, the demand for water for industries will increase significantly. Further practically all industries generate some waste. As of now, the performance of affluent treatment system in the industries is far from satisfactory and this effluent is polluting our water bodies. The industries have to stick to the norms to treat their waste accordingly. In the process part of their demands can be met by the industries themselves with suitable treatment and recycling. Industries generating hazardous waste may have to be located in area having suitable sites for waste disposal, as the present practice being adopted are very detrimental to the overall environment. Water requirements of the country would continue to grow partly due to the rise in population and partly as a result of the improvement in the quality of life. As the developmental efforts to meet the water requirements take shape, simultaneously the environmental issues gain importance. Although, less evident than the more obvious quantity related problems, these are critically important and need to be addressed to ensure sustainable development which is a formidable challenge, but one which can be accepted and negotiated successfully.

#### **1.4 WATER QUALITY MANAGEMENT**

Water quality is a major environmental concern in developing countries. Pollution of waters of rivers, streams and lakes is mainly the fallout of rapid urbanization, industrialization and inadequate storage of flood flows for meeting the needs of water supply and sanitation sectors. The main sources of water pollution are discharge of domestic sewage and industrial effluents, which contain organic pollutants, chemicals and heavy metals, and runoff from land based activities such as agriculture and mining. Further, bathing of animals, washing of clothes and dumping of garbage into the water bodies also contribute to water pollution. All these factors have led to pollution of rivers, lakes, coastal areas and groundwaters seriously damaging the

eco-systems. Effective environmental laws to check water pollution need to be enforced with greater vigour. The rivers and water bodies should not be used as a source for water supplies as well as convenient sink for wastewater discharges. The rapid urbanization, industrialization and increasing use of chemical fertilizers and pesticides etc. have made our rivers and water bodies highly polluted. Different organizations like Central Pollution Control Board, Central Water Commission, and Central Groundwater Board are involved in water quality monitoring. Water quality Assessment Authority (WQAA) has been set up recently to effectively coordinate and improve the work of water quality monitoring by various organizations. As of now there is no established method to assess requirements of minimum flow in the rivers. Perhaps, 50 per cent of lean period flow before the structure is built over and above the committed use may be passed on downstream of all existing and new structures.

### 1.5 FRESH WATER MANAGEMENT

The availability of fresh water is going to be the most pressing problem over the coming decades. The stress on water resources is a result of multiple factors namely urban growth, increased industrial activities, intensive farming, and the overuse of fertilizers and other chemicals in agricultural production. Untreated water from urban settlements and industrial activities, and run-off from agricultural land carrying chemicals, are primarily responsible for deterioration of water quality and contamination of lakes, rivers, and groundwater aquifers.

The Government of India formulated the National Water Policy in 1987 to provide top priority to drinking water supply and undertook the National River Action Plan to clean up polluted river stretches. Following measures needed to increase the availability of fresh water.

- Emphasis should be given to adopting a river basin approach or sub-basin-based approach, which integrates all aspects of water management namely water allocation, pollution control, protection of water resources, and mobilization of financial resources.
- Each state should prepare water policies. The National Water Policy of 1987 also needs to be revised urgently. Groundwater legislation needs to be promulgated in all states to promote sustainable water uses and development. Incentives under the Water Cess Act have to be made more attractive.
- Emphasis should be given to rain water harvesting to increasing water resource availability. Watershed development must be adopted more rigorously. People's participation is the essential prerequisite for watershed development and to this end, public education and training to local people is to be provided.
- An appropriate tariff structure for water services will have to be evolved to encourage wide usage. There is also a need to develop and implement cost effective water appliances such as low flow cistern and faucets.
- Technological intervention is required to enhance effective treatment of wastewater. Adoption of cleaner technologies by the industry would help to safeguard surface waterbodies.
- Data on water supply and sanitation for both urban and rural areas need to be collected to formulate strategies and priorities and action plan. Similarly, information on water

consumption and effluent discharge patterns for industries would help to benchmark resource consumption and increase the productivity levels per unit of water consumed.

- The availability of utilizable water resources, demand levels and consumption patterns needs to be analyzed for different basins. Such an analysis would help in developing a Water Zoning Atlas to guide decisions related to the sitting of industries and other economic activities.

### **1.6 WASTEWATER MANAGEMENT**

Rapid industrialization calls for wastewater treatment and its disposal to be so planned and sited so as to protect people, the quality of water (both surface and ground) and environment from adverse impacts. The industrial units must set up effluent treatment plants for treating the wastewater to the desired standard before releasing to waterbodies. Effective checks and monitoring should be placed in position and deterrent punitive measure be taken against defaulting units. These should be open for inspection by the State Pollution Control Board for action. For small units located in various industrial estates common effluent treatment plants be set up and the industry should share the capital and O & M cost of the plants. Toxic effluents, however, are not segregated in the industries and are often discharged mixed with other effluents. Generally, wastewater of industries such as sugar, distilleries, dairies, tanneries etc. can be treated by biological methods such as stabilization ponds, activated sludge process, trickling filtration, aerated lagoons etc. Other industrial wastes such as pulp and paper synthetic fibre etc. have to undergo simple physico-chemical methods of treatment, but the industries discharging toxic wastes such as electro-plating, metallurgical, caustic chlorine etc. may require more elaborate techniques.

### **1.7 RECYCLING AND REUSE OF WATER**

As the demand in industries is going to increase, the technological development in processing and methods of reusing water are expected to reduce the demand of fresh water. Recycling is defined as the internal use of wastewater by the original user prior to discharge to a treatment system or other point of disposal. Wastewater is recovered, treated or untreated and then recycled for repetitive use by the same user. The term reuse applies to wastewaters that are discharged and then withdrawn by a user other than the discharger. Reclaimed waters from wastewater after treatment are generally used for “agricultural” irrigation, cooling water, algal cultivation and pisciculture, apart from other industrial uses. India though predominantly rural has still a large urban population. The urban centers are also the nuclei of industrial growth. The wastes (effluents), if reused within the industry with/without treatment as permissible would help in minimizing fresh water requirements while achieving reduction in wastewater volume for final treatment before discharge, deriving economy at both ends.

In most cases industrial water uses are non-consumptive making reuse possible through recycling and conservation measures. Recycling of wastewater also helps in recovery of certain commercially viable by-products. Process industries are major users of water and can recycle or reuse water wastes for lesser duty purpose. Cascade concept is adopted for reusing water

discarded from a process requiring higher purity to a process requiring lower purity. If required, a simple treatment process may be interposed between the processes. Water reuse is more economical if included at the design stage by modification of the existing system. In most of the inland towns, in arid and semiarid areas, where suitable lands are generally available in the nearby areas for development of irrigation, treated effluent can economically be used for industrial effluents are used for irrigation. The water recovered from effluents is mainly used for less important uses like gardening and cleaning. It is necessary to improve the production technology, and low or no waste technology needs to be adopted. Though, such technologies may be costly at the initial stage, it would prove economical in the long run. The municipal wastewater and industrial effluent are being treated up to tertiary level and used for various purposes other than drinking by various industries and cities. For example, in Chennai the Chennai Metro Board is providing 30 mld treated municipal wastewater to Ennore Thermal Power Plant for recycle and reuse for cooling and other purposes. Likewise in Bombay, many of the industrial houses are using the recycled industrial effluent for purposes such as airconditioning, cooling etc. In Pondicherry Ashram, the wastewater from housing complexes and community's toilets are recycled and reused for horticulture purposes and irrigation. State Governments may create Urban Development Fund for Urban Infrastructure development and the same can also be used for setting up of pilot projects for waste reuse, recycling and resource recovery.

### **1.8 NEED FOR TECHNOLOGY DEVELOPMENT**

Water requirement for Industries varies tremendously as industrial growth is also associated with technological changes. Also with number of Thermal and Nuclear Plants coming up, water use efficiency for cooling will have to go up to cater to the increased demand. The dry cooling tower technique is one of the water saving method suggested for this purpose. Also the cost of industrial water recycling varies from site to site. Recycling depends on comparison of cost of water treatment prior to disposal with that of treatment of wastewater for reuse within the plants. The recycling cost may work out less in future as cost of wastewater treatment is going up. It is suggested that our research efforts need to be oriented towards evolving appropriate technology to ensure efficient use of cooling and process water, development of pollution control mechanism, development of appropriate cost effective technologies for treatment of waste water for reuse and development of cost effective technologies for recycling of water.

Use of biotechnology is suggested for treatment of polluted water, when pollutants are biodegradable. Domestic sewage, which contains mostly the biodegradable pollutants, has been treated by microorganisms since the old times. Difficulty lies due to many modern vulnerable industrial wastes, which are generally not degradable by conventional methods. New researches in the field of biotechnology are opening the possibility of treatment of such types of industrial wastes in cost-effective manner. At the global level, use of biotechnology has already become popular. In India, biotechnology is now on the fast track and we should increase our share in global market, particularly for wastewater management. With the availability of water becoming scarce, technological upgradation is necessary in field of agronomy so as to maximize productivity

per unit of water and land. Following measure may also be considered for adoption through intensified efforts of academicians and field technologists.

Deficit Irrigation is the scheduling method applied under a restricted water supply, when irrigation does not fully meet the evapo-transpiration requirements of the crop and where certain stress conditions are allowed. The specific objective is to optimize yields and incomes by allowing water to the most sensitive crop stages and for valuable crops. Strategies for deficit irrigation may include allocation of less water to the most drought tolerant crops, irrigation during critical growth stages of crops, planting crops so as to stagger the critical demand periods and planting for an average or wetter than average weather year. In drought prone areas, deficit irrigation, rather than full irrigation, can be planned as a norm, in order to distribute the benefit of drought proofing over a larger area.

Agriculture is at threshold of commercialization. There is need to shift focus from routine food grains production systems to newer cropping system to meet the ever-increasing demand of pulses, oilseeds, fodder, fibre, fuel, spices, vegetables, medicinal and other commercial crops and make agriculture an attractive and profitable business. This has become more important today in the light of national policy of economic liberalization and export orientation of agriculture. Crop diversification methods like crop rotation, mixed cropping and double cropping have been found successful in many situations. Major advantages of these types of diversification includes reduced erosion, improved soil fertility, increased yield, reduction in need for nitrogen fertilizer in the case of legumes, and reduced risk of crop failure. Diversity of crop varieties can enhance the stability of yield and result in water saving. Thus, generic diversity and location specific varieties are essential for achieving sustainable production.

Raw wastewater has been in use for crops and fish production in several countries including India without the approval of the competent authorities. Providing financial assistance and technical guidance in improving existing practices, not only to minimize health risks but also to increase productivity is preferable to outright prohibition. Generally, the upgrading of existing schemes may take precedence over the development of new projects. Treatment of wastewater in stabilization ponds in an effective and low-cost method of pathogen removal, and is, therefore, suitable for schemes for wastewater reuse, particularly for irrigation of crops. Similarly, duckweed ponds are quite effective in treating municipal wastewater and at the same time the harvested duckweed is a good fish and chicken feed. As such, there is a need to develop appropriate and cost-effective technologies, for treatment and reuse of municipal wastewater, suitable to Urban Local Bodies for their adoption. Possible health risks to agricultural workers should, however, be assessed thoroughly and monitored regularly. The treated wastewater should conform to the pollution control standards where such reuse practice is adopted.

### **1.9 WATER CONSERVATION**

In arid and semi-arid areas, the low and erratic rainfall normally occurs with high intensity of short duration resulting in high run-off and poor soil moisture storage. As a result, the loss is about 50 to 60 per cent of rainwater. Runoff varies from 10 to 30 per cent of the rainfall depending on the amount and intensity of rain, soil characteristics and vegetation cover. This

surface runoff if harvested over a large area can yield considerable amount of water for storage and providing life saving irrigation to the crop during the dry spells in the monsoon season and also for growing a second crop in rabi season. The major constraints that still limit the adoption of this technology on a macro scale are, the high initial cost, and non-availability of cheap and defective sealants for permeable Alfisols. Additionally, long breaks in the monsoon and low intensity rains limit the runoff flow into the ponds during dry spells when water is needed most. Despite these difficulties, small water storage ponds seem to be the most viable strategy to stabilize productivity of the ecologically disadvantaged dry land regions. The surface runoff from an area can also be increased by reducing the infiltration capacity of the soil through vegetation management, cleaning, sloping surface vegetation and reducing soil permeability by application of chemicals. To maximize profitability from the limited quantity of water stored in small ponds, planning for its judicious use is most crucial. Research conducted at different locations in India established that a supplemental irrigation of 5 – 10 cm at the critical stage of crop growth substantially increases the yields of cotton, wheat, sorghum, tobacco, pearl, millet, etc vis-à-vis no irrigation.

Therefore one has to conserve the surface runoff by different techniques, for use in fair weather.

*These techniques are:*

- (a) Conservation by surface storage — Storage of water by construction of various water resources projects has been one of the oldest measures of water conservation. The scope of storage depends on region to region depending on water availability and topographic condition. The environmental impact of such storage also needs to be examined for developing environment friendly strategies.
- (b) Conservation of rainwater — Rainwater has been conserved and used for agriculture in several parts of our country since ancient time. The infrequent rain if harvested over a large area can yield considerable amount of water. The example of such harvesting techniques involves water and moisture control at a very simple level. It often consists of rows of rocks placed along the contour of steps. Contour terraces have been found in use in various parts of the world. Runoff captured by these barriers also allows for retention of soil, thereby serving as erosion control measures on gentle slopes. This technique is especially suitable for areas having rainfall of considerable intensity, spread over large part i.e., in Himalayan area, North – East states, and Andaman and Nicobar Island. In areas where rainfall is scanty and for a short duration, it is worth attempting this technique, which will induce surface runoff, which can be stored.
- (c) Groundwater conservation — As highlighted earlier, out of total 400 mham precipitation occurs in India, about 45 mham percolates as a groundwater flow. It may not be possible to tap the entire groundwater resources. The entire groundwater cannot be harvested. As we have limited groundwater available, it is very important that we use it economically and judiciously and conserve it to maximum possible. Some of the techniques of groundwater management and conservation are as below:
  - (i) Artificial recharge — In water scarce areas, where there is a low and erratic rainfall, there is an increased dependence on groundwater. There are various techniques



to develop and manage groundwater artificially. In one of the methods, water is spread over ground to increase area and length of time for water to remain in contact with soil, to allow maximum possible quantity of water to enter into the ground. Digging recharge wells, which admit water from the surface to fresh water aquifer, can also do the artificial recharging.

- (ii) Percolation Tank Method<sup>3/4</sup> Percolation tanks are constructed across the watercourse for artificial recharge. The studies conducted indicates that on an average, area of influence of percolation of 1.2 km<sup>2</sup>, the average groundwater rise was of the order of 2.5 m and the annual artificial recharge to groundwater from each tanks was 1.5 hectare meter.
- (iii) Catchment area protection (CAP) — Catchment area protection plans are usually called Watershed Protection or Management Plans, these are adopted as an important measure to conserve and protect the quality and quantity of water in a watershed. It helps in with holding runoff water albeit temporarily by a check bund constructed across the streams on hilly terrain, which will delay the runoff so that greater time is available for water to seep underground. Such methods are in use in North East states, in hilly areas of tribal belts. This technique also helps in soil conservation. Afforestation in the catchment area is also adopted for water and soil conservation.

#### 1.10 NEED OF ENSURING QUALITY & COST-EFFECTIVENESS OF WATER HARVESTING

It is strongly suggested that detailed studies may be undertaken to compare the unit cost and quality indices for different alternates of groundwater recharge like large and mega dams, small and run of river diversion schemes, small tanks, bhandaras, check dams, watershed development, catchments area treatment, roof top harvesting, field water harvesting, contour terracing, bunding etc. The quantitative aspects, limitations, suitability and the quantum need of various alternates for groundwater recharging should also be studied and compared in different Indian regions to meet competing demands particularly the bulging concentrated demands in mega urban cities. The benefits like hydropower, irrigation, tourism, recreation, flood moderation, drought proofing, pisciculture, horticulture, employment generation, check on voluntary migration for want of employment particularly from dry/unirrigated areas to irrigated agricultural areas should also be accounted for while considering the technical feasibility, economic viability, cost effectiveness and environmental sustainability for various alternates.

The need, procedure and budget for maintenance and repairs of above alternates should also be considered before finalizing the proposed act/policy/guidelines for compulsory/accelerated rooftop harvesting in various municipal area.

#### 1.11 DEVELOPMENT OF INTERNATIONAL RIVER BASINS

With increasing demand for water for various uses conflicts arise between nations sharing the same river basin. The importance of shared water resources has not been realized so far. As a result, the conflicts are going to intensify in future. National boundaries divide the catchments/

drainage basins. The problems arise when the competing demands exceed the limited water resources available in the dry months.

On a global basis, there are 214 river basins that are shared by two or more countries.

<i>Country</i>	<i>River Basins</i>
Africa	57
Asia	40
Europe	48
North & Central Africa	33
South Africa	36
	214

There are 44 countries where at least 80 percentage of total area falls within an International River Basins of which 7 are in Asia. In the South Asian sub-continent, there are three as shown below:

<i>Countries</i>	<i>Total Area km<sup>2</sup></i>	<i>Area within an Int. Basin km<sup>2</sup></i>	<i>Percentage Country within the Int. Basin</i>
Bangladesh	142,780	123,300	86
Bhutan	47,000	47,000	100
Nepal	140,800	140,800	100

During the past decades, conflicts have emerged over the development and management of the shared water of International Rivers in many parts of the World. The conflict between Bangladesh and India on the Ganges is one of them.

With increasing population and need for further economic development, the pressure on scarce water resources will be more in the future. There is, therefore, an urgent need to identify the existing and emerging conflicts in the basins and discuss, and resolve the issues in a spirit of cooperation for overall development and management of the river basins.

### ***The Ganges, the Brahmaputra and the Meghna River Basin***

Three internal rivers, the Ganges, the Brahmaputra and the Meghna pass through multiple countries. These rivers system drain an area of 1.75 sq. km in China. Nepal, India, Bhutan and Bangladesh of which only 7 per cent lies in Bangladesh, 63 per cent in India, 8 per cent in Nepal and 2.58 per cent in Bhutan and the rest in Tibet. The region has a population of 535 million of which 405 million in India, 120 million in Bangladesh, 18.5 million in Nepal and 1.5 million in Bhutan. The region is very large and the climatic conditions differ widely from place to place. The area is also prone to natural disasters like flood, drought, cyclone and earthquake.

The region is one of the poorest in the World but rich in natural resources like water and land. Cooperation among the nations is a prerequisite for development. Regional concept is

essential for developing together for self-reliance and ecologically sustainable development for a better future.

With increasing population and demand for food and growing concern for environmental degradation demand for water will increase resulting in conflicts among nations sharing international river basins.

**The Ganges:** The Ganges covers an area of about 1,087,300 sq. km. spread over India (860,000 sq. km.), Nepal (147,480 sq. km.), China (33,520 sq. km.) and Bangladesh (46,300 sq. km.). The length of the main river is about 2550 km. Three major tributaries of the Ganges, the Karnali, the Gandaki and the Kosi rise in China and flow through Nepal to join the Ganges in India, contributing 71 per cent of the dry season flows and about 41 per cent of the annual flows. The Ganges forms the common boundary between India and Bangladesh for about 104 km. The river then flows southeastward inside Bangladesh for about 157 km. and joins the Brahmaputra at Goalundo. The recorded maximum and minimum flows in the Ganges at Hardinge Bridge were 76,000 cumec and 263 cumec.

**The Brahmaputra:** The Brahmaputra has a total catchments area of 552,000 sq. km. spread over China (270,900 sq. km.), Butan (47,000 sq. km.), India (195,000 sq. km.) and Bangladesh (39,100 sq. km.). The Brahmaputra originates in the Himalayan range and collects snowmelt and runoff from the catchments lying in China, Bhutan, India and Bangladesh. The river after entering Bangladesh flows southward and continues to its confluence with the Ganges near Aricha. The total length of the Brahmaputra is about 2900 km. up to Aricha. The recorded maximum flow in the Brahmaputra at Bahadurabad was 98,300 cumec while the minimum was 2,860 cumec.

**The Meghna:** The Barak, headstream of the Meghna rises in the hills of Manipur in India. Near the Indo-Bangladesh border, the Barak bifurcates into two rivers: the Surma and the Kushiara which again join together at Ajmirigonj in Bangladesh. The combined flow takes the name of Meghna and flows in a southwesterly direction to meet the Padma at Chandpur. Below Chandpur the combined flow is known as the lower Meghna. The total length of the river is about 902 km. of which 403 km. is in Bangladesh. The total catchments area of Meghna is 82,000 sq. km. out of which 47,000 sq. km. and lie in India and Bangladesh respectively. The recorded maximum discharge of the Meghna at Bhairab Bazar was 19,800 cumec.

# 2

# HYDROLOGICAL CYCLE

## 2.1 INTRODUCTION

Water is the most widespread substance to be found in the natural environment. Water exists in three states: liquid, solid, and invisible vapour. It forms the oceans, seas, lakes, rivers and the underground waters found in the top layers of the Earth's crust and soil cover. In a solid state, it exists as ice and snow cover in polar and alpine regions. A certain amount of water is contained in the air as water vapour, water droplets and ice crystals, as well as in the biosphere. Huge amounts of water are bound up in the composition of the different minerals of the Earth's crust and core.

To assess the total water storage on the Earth reliably is a complicated problem because water is so very dynamic. It is constantly changing from liquid to solid or gaseous phase, and back again. It is usual to estimate the quantity of water found in the so-called hydrosphere. This is all the free water existing in liquid, solid or gaseous state in the atmosphere, on the Earth's surface and in the crust down to a depth of 2000 meters. Current estimates are that the Earth's hydrosphere contains a huge amount of water — about 1386 million cubic kilometers. However, 97.5% of these amounts are saline waters and only 2.5% is fresh water. The greater portion of this fresh water (68.7%) is in the form of ice and permanent snow cover in the Antarctic, the Arctic, and in the mountainous regions. Next, 29.9% exists as fresh ground waters. Only 0.26% of the total amount of fresh waters on the Earth is concentrated in lakes, reservoirs and river systems where they are most easily accessible for our economic needs and absolutely vital for water ecosystems.

These are the values for natural, static, water storage in the hydrosphere. It is the amount of water contained simultaneously, on average, over a long period of time — in waterbodies, aquifers, and the atmosphere. For shorter time intervals such as a single year, a couple of seasons, or a few months, the volume of water stored in the hydrosphere will vary as water exchanges take place between the oceans, land and the atmosphere. This exchange is usually called the turnover of water on the Earth, or the global hydrological cycle, as shown in Fig. 2.1.

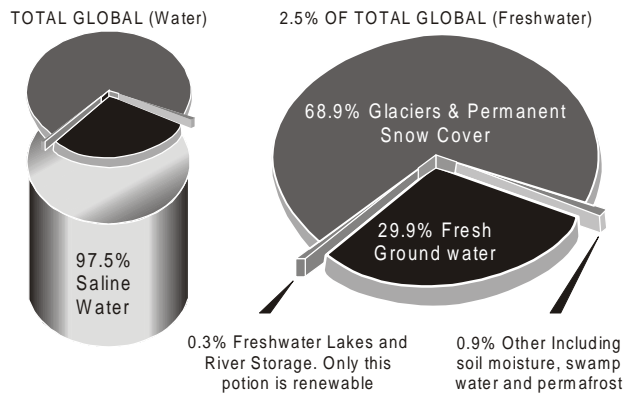

Fig. 2.1 Global hydrological cycle.

Solar heat evaporates water into the air from the Earth's surface. Land, lakes, rivers and oceans send up a steady stream of water vapour; this spreads over the surface of the planet before falling down again as precipitation. Precipitation falling on land is the main source of the formation of the waters found on land: rivers, lakes, groundwater, and glaciers. A portion of atmospheric precipitation evaporates; some of it penetrates and charges groundwater, while the rest — as river flow — returns to the oceans where it evaporates: this process repeats again and again. A considerable portion of river flow does not reach the ocean, having evaporated in the endotherm regions, and those areas with no natural surface runoff channels. On the other hand, some groundwater bypasses river systems altogether and goes directly to the ocean or evaporates. Quantitative indices of these different components of the hydrological cycle are shown in Figure 2.2. Every year the turnover of water on Earth involves 577,000 km<sup>3</sup> of water. This is water that evaporates from the oceanic surface (502,800 km<sup>3</sup>) and from land (74,200 km<sup>3</sup>). The same amount of water falls as atmospheric precipitation, 458,000 km<sup>3</sup> on the ocean and 119,000 km<sup>3</sup> on land. The difference between precipitation and evaporation from the land surface (119,000 – 74,200 = 44,800 km<sup>3</sup>/year) represents the total runoff of the Earth's rivers (42,700 km<sup>3</sup>/year) and direct groundwater runoff to the ocean (2100 km<sup>3</sup>/year). These are the principal sources of fresh water to support life necessities and man's economic activities.

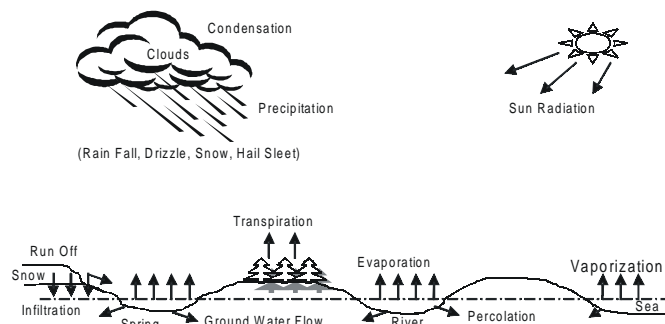

Fig. 2.2 The hydrological cycle.

Oceans cover most of the Earth's surface. On average, the depth of the world's oceans is about 3.9 kilometers. However, maximum depths can be greater than 11 kilometers. The distribution of land and ocean surfaces on the Earth is not homogeneous. In the Southern Hemisphere there is 4 times more ocean than land. Ratio between land and ocean is almost equal in the Northern Hemisphere. Geographers recognize three major ocean basins: Pacific; Atlantic; and Indian.

The water found in the ocean basins is primarily a byproduct of the lithospheric solidification of rock that occurred early in the Earth's history. A second source of water is volcanic eruptions. The dissolved constituents found in the ocean come from the transport of terrestrial salts in weathered sediments by leaching and stream runoff. Seawater is a mixture of water and various salts. Chlorine, sodium, magnesium, calcium, potassium, and sulfur account for 99% of the salts in seawater. The presence of salt in seawater allows ice to float on top of it. Seawater also contains small quantities of dissolved gases including: carbon dioxide, oxygen, and nitrogen. These gases enter the ocean from the atmosphere and from a variety of organic processes. Seawater changes its density with variations in temperature, salinity, and ocean depth. Seawater is least dense when it is frozen at the ocean surface and contains no salts. Highest seawater densities occur at the ocean floor.

The hydrologic cycle is used to model the storage and movement of water between the biosphere, atmosphere, lithosphere and hydrosphere. Water is stored in the following reservoirs: atmosphere, oceans, lakes, rivers, glaciers, soils, snowfields, and groundwater. It moves from one reservoir to another by processes like: evaporation, condensation, precipitation, deposition, runoff, infiltration, sublimation, transpiration, and groundwater flow.

River water is of great importance in the global hydrological cycle and for the supply of water to humankind. This is because the behaviour of individual components in the turnover of water on the Earth depends both on the size of the storage and the dynamics of water movement. The different forms of water in the hydrosphere are fully replenished during the hydrological cycle but at very different rates. For instance, the period for complete recharge of oceanic waters takes about 2500 years, for permafrost and ice some 10,000 years and for deep groundwater and mountainous glaciers some 1500 years. Water storage in lakes is fully replenished over about 17 years and in rivers about 16 days.

Based on water exchange characteristics, two concepts are often used in hydrology and water management to assess the water resources in a region: the static storage component and the renewable waters. The static storage conventionally includes freshwater with a period of complete renewal taking place over many years or decades such as large lakes, groundwater, or glaciers. Intensive use of this component unavoidably results in depleting the storage and has unfavorable consequences. It also disturbs the natural equilibrium established over centuries, whose restoration would require tens or hundreds of years.

Renewable water resources include waters replenished yearly in the process of the water turnover of the Earth. These are mainly runoff from rivers, estimated as the volume per unit

of time ( $\text{m}^3/\text{s}$ ,  $\text{km}^3/\text{year}$ , etc.) and formed either within a specific region or from external sources, including groundwater inflow to a river network. This kind of water resource also includes the yearly renewable upper aquifer groundwater not drained by the river systems. However, on the global scale, these volumes are not large compared with the volume of river runoff and are of importance only for individual specific regions.

**Table 2.1 Periods of water resources renewal on the earth**

<i>Water of Hydrosphere</i>	<i>Period of Rrenewal</i>
World Ocean	2500 years
Groundwater	1400 years
Polar ice	9700 years
Mountain glaciers	1600 years
Ground ice of the permafrost zone	10,000 years
Lakes	17 years
Bogs	5 years
Soil moisture	1 year
Channel network	16 days
Atmospheric moisture	8 days
Biological water	Several hours

In the process of turnover, river runoff is not only recharged quantitatively, its quality is also restored. If only man could suddenly stop contaminating rivers, then with time water could return to its natural purity. Thus, river runoff, representing renewable water resources, is the most important component of the hydrological cycle. It exerts a pronounced effect on the ecology of the earth's surface and on human economic development. It is river runoff that is most widely distributed over the land surface and provides the major volume of water consumption in the world.

## 2.2 ATMOSPHERIC WATER

Atmospheric water exists as water vapour, droplets and crystals in clouds. The actual volume of water in the atmosphere is very small and varies with changes in temperature, pressure and geographical location. Water vapour can move long distances in the atmosphere in a relatively short period of time because of the high velocity winds in the upper atmosphere. The average water molecule is in the atmosphere for 12 days before it precipitates. The atmospheric movement of water vapor from sea to land and land to sea seems to be unbalanced. Twenty percent of water vapour from the oceans moves inland but only 12 percent moves out to sea. However, this exchange is balanced by runoff water that flows from the land to the sea.

### 2.3 PRECIPITATION

Water evaporated from oceanic surfaces (86%) combines with water evaporated from the land (14%) to produce clouds. Seventy-eight percent of all rain falls on the oceans. The remaining 22% falls on land. Hence, the land receives a net moisture donation from the oceans. Precipitation can be defined as any aqueous deposit, in liquid or solid form, that develops in a saturated atmospheric environment and generally falls from clouds. A number of different precipitation types have been classified by meteorologists including rain, freezing rain, snow, ice pellets, snow pellets, and hail. Fog represents the saturation of air near the ground surface. Classification of fog types is accomplished by the identification of the mechanism that caused the air to become saturated. The distribution of precipitation on the Earth's surface is generally controlled by the absence or presence of mechanisms that lift air masses to cause saturation. It is also controlled by the amount of water vapor held in the air, which is a function of air temperature. A figure is presented that illustrates global precipitation patterns.

Precipitation is often intercepted by vegetation before it reaches the surface of the ground. However, precipitation, which reaches the ground, follows two basic pathways: surface flow and infiltration. Some water soaks into the subsurface through infiltration, this water moves through the pores of the soil until the soil reaches saturation. Infiltration lessens with soil saturation leading to surface flow. Once infiltrated, water continues to filter through soil or rock through vertical movement called *percolation*. Percolation results in the movement of water from the soil layer to the groundwater. This is usually seasonal, occurring only when the soil is saturated and when roots and evaporation are not resulting in a net movement of soil water towards the surface.

In certain locations on the Earth, acid pollutants from the atmosphere are being deposited in dry and wet forms to the Earth's surface. Scientists generally call this process acid deposition. If the deposit is wet, it can also be called acid *precipitation*. Normally, rain is slightly acidic. Acid precipitation, however, can have a pH as low as 2.3.

The distribution of precipitation falling on the ground surface can be modified by the presence of vegetation. Vegetation in general, changes this distribution because of the fact that it intercepts some of the falling rain. How much is intercepted is a function of the branching structure and leaf density of the vegetation. Some of the water that is intercepted never makes it to the ground surface. Instead, it evaporates from the vegetation surface directly back to the atmosphere. A portion of the intercepted water can travel from the leaves to the branches and then flow down to the ground via the plant's stem. This phenomenon is called stem flow. Another portion of the precipitation may flow along the edge of the plant canopy to cause canopy drip. Both of the processes described above can increase the concentration of the water added to the soil at the base of the stem and around the edge of the plant's canopy. Rain that falls through the vegetation, without being intercepted, is called through fall.

### 2.4 SURFACE WATER

Despite the ecological significance of surface water, it comprises only a very small proportion of the world's water. Surface flow can occur in four ways: as overland flow, as through flow, as groundwater flow and as stream flow in rivers and streams. Overland flow occurs only when the soil layer is saturated and storage basins (lakes, wetlands, rivers) are full. It occurs at



the end of storm events and during ice melt in spring. It is relatively rare in natural environments (e.g. forested), but is more common in urban and even rural areas. Through flow is the movement of water laterally through the soil and it occurs most commonly on slopes.

Groundwater flows beneath the surface beyond the soil-moisture root zone. Excess surface water moves through soil and rock until it reaches the water table. The water table is the upper limit of groundwater and is the contact point between saturated and aerated rocks and soils. Groundwater flows from areas with a higher water table to areas where the water table is lower. There is often a distinction between shallow groundwater flowing through glacial sands and gravels and deep groundwater flowing through underlying bedrock. An aquifer is a permeable layer of rock, which can both store and transmit large amounts of groundwater.

Eight per cent of water travels from the land to oceans via surface flow. Ninety-five percent of this surface flow returns to the ocean as overland flow and stream flow. Only 5% returns to the ocean by means of slow-moving groundwater. These percentages indicate that the small amounts of water in rivers and streams are very dynamic, whereas the large quantities of sub-surface groundwater are sluggish.

Runoff is the surface flow of water to areas of lower elevation. On the micro scale, runoff can be seen as a series of related events. At the global scale runoff flows from the landmasses to the oceans. The Earth's continents experience runoff because of the imbalance between precipitation and evaporation.

## 2.5 INFILTRATION

Infiltration is the movement of water from precipitation into the soil layer. Infiltration varies both spatially and temporally due to a number of environmental factors. After a rain, infiltration can create a condition where the soil is completely full of water. This condition is, however, only short-lived as a portion of this water quickly drains (gravitational water) via the force exerted on the water by gravity. The portion that remains is called the *field capacity*. In the soil, field capacity represents a film of water coating all individual soil particles to a thickness of 0.06 mm. The soil water from 0.0002 to 0.06 mm (known as capillary water) can be removed from the soil through the processes of evaporation and transpiration. Both of these processes operate at the surface. Capillary action moves water from one area in the soil to replace losses in another area (biggest losses tend to be at the surface because of plant consumption and evaporation). This movement of water by capillary action generally creates a homogeneous concentration of water throughout the soil profile. Losses of water stop when the film of water around soil particles reaches 0.0002 mm. Water held from the surface of the soil particles to 0.0002 mm is essentially immobile and can only be completely removed with high temperatures (greater than 100 degrees Celsius). Within the soil system, several different forces influence the storage of water.

## 2.6 GROUNDWATER

Groundwater is all the water that has penetrated the earth's surface and is found in one of two soil layers. The one nearest the surface is the "zone of aeration", where gaps between soils are

filled with both air and water. Below this layer is the “zone of saturation”, where the gaps are filled with water (Fig. 2.3). The water table is the boundary between these two layers. As the amount of groundwater increases or decreases, the water table rises or falls accordingly. When the entire area below the ground is saturated, flooding occurs because all subsequent precipitation is forced to remain on the surface.

Through flow is the horizontal subsurface movement of water on continents. Rates of through flow vary with soil type, slope gradient, and the concentration of water in the soil. Groundwater is the zone in the ground that is permanently saturated with water. The top of groundwater is known as the water table. Groundwater also flows because of gravity to surface basins of water (oceans) located at lower elevations.



**Fig. 2.3 Groundwater zones.**

The amount of water that can be held in the soil is called “porosity”. The rate at which water flows through the soil is its “permeability”. Different surfaces hold different amounts of water and absorb water at different rates. Surface permeability is extremely important for hydrologists to monitor because as a surface becomes less permeable, an increasing amount of water remains on the surface, creating a greater potential for flooding. Flooding is very common during winter and early spring because the frozen ground has no permeability, causing most rainwater and melt water to become runoff.

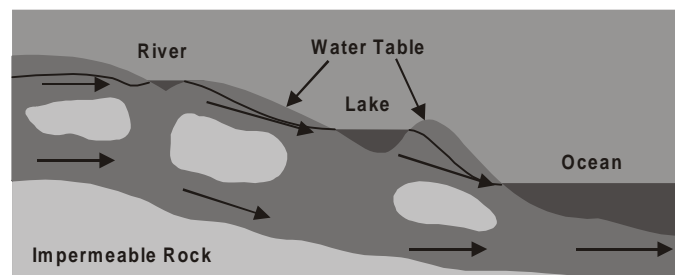

**Fig. 2.4 Groundwater flow.**

Water that infiltrates the soil flows downward until it encounters impermeable rock (shown in grey), and then travels laterally (Fig. 2.4). The locations where water moves laterally are called *aquifers*. Groundwater returns to the surface through these aquifers (arrows), which empty into lakes, rivers, and the oceans. Under special circumstances, groundwater can even

flow upward in artesian wells. The flow of groundwater is much slower than runoff, with speeds usually measured in centimeters per day, meters per year, or even centimeters per year.

Comparison of Advantages of Surface versus Subsurface Water Reservoirs:

The comparison of advantages between surface and subsurface storage are given in the following Table (USDI 1985).

**Table (USDI 1985)**

<i>Subsurface Reservoirs</i>	<i>Surface Reservoirs</i>
Many large capacity sites are available	Few sites available
Slight to no evaporation loss	High evaporation loss even in humid climate
Require little land area	Require large land area
Slight to no danger of catastrophic structural failure	Ever present danger of catastrophic failure
Uniform water temperature	Fluctuating water temperature
High biological purity	Easily contaminated
Reservoir serves as conveyance system	Water must be conveyed
Water must be pumped	Water may be available by gravity flow
Water may be mineralized	Water generally of relatively low mineral content
Difficult and costly to investigate, evaluate and manage	Relatively easy to investigate, evaluate and manage
Recharge opportunity usually dependent on surplus surface flows	Dependent on annual precipitation
Recharge water may require expensive treatment	No treatment required
Continuous expensive treatment of recharge areas or wells	Little treatment required
Minor flood control value	Maximum flood control value

**2.7 EVAPO-TRANSPIRATION**

Evaporation and transpiration are the two processes that move water from the Earth’s surface to its atmosphere. Evaporation is movement of free water to the atmosphere as a gas. It requires large amounts of energy. Transpiration is the movement of water through a plant to the atmosphere. Scientists use the term evapo-transpiration to describe both processes. In general, the following four factors control the amount of water entering the atmosphere via these two processes: energy availability; the humidity gradient away from the evaporating surface; the wind speed immediately above the surface; and water availability. Agricultural scientists

sometimes refer to two types of evapo-transpiration: Actual Evapo-transpiration and Potential Evapo-transpiration. The growth of crops is a function of water supply. If crops experience drought, yields are reduced, irrigation can supply crops with supplemental water. By determining both actual evapo-transpiration and potential evapo-transpiration a farmer can calculate the irrigation water needs of their crops.

The distribution of precipitation falling on the ground surface can be modified by the presence of vegetation. Vegetation in general, changes this distribution because of the fact that it intercepts some the falling rain. How much is intercepted is a function of the branching structure and leaf density of the vegetation. Some of the water that is intercepted never makes it to the ground surface. Instead, it evaporates from the vegetation surface directly back to the atmosphere. A portion of the intercepted water can travel from the leaves to the branches and then flow down to the ground via the plant's stem. This phenomenon is called stem flow. Another portion of the precipitation may flow along the edge of the plant canopy to cause canopy drip. Both of the processes described above can increase the concentration of the water added to the soil at the base of the stem and around the edge of the plant's canopy. Rain that falls through the vegetation, without being intercepted, is called through fall.

## 2.8 RECHARGE

Recharge is the process that allows water to replenish an aquifer. This process occurs naturally when rainfall filters down through the soil or rock into an aquifer. Artificial recharge is achieved through the pumping (called injection) of water into wells or by spreading water over the surface where it can seep into the ground. The land area where recharge occurs is called the *recharge area* or *recharge zone*.

When the withdrawal of groundwater in an aquifer exceeds the recharge rate over a period of time, the aquifer is over withdrawal. There are two possible effects from the over withdrawal of water from an aquifer.

First, when the amount of fresh water being pumped out of an aquifer in a coastal area cannot be replaced as fast as it is being withdrawn, salt water migrates towards the point of withdrawal. This movement of salt water into zones previously occupied by fresh water is called *salt-water intrusion*. Salt-water intrusion can also occur in inland areas where briny water underlies fresh water.

Secondly, in some areas over withdrawal can make the ground sink because groundwater pressure helps to support the weight of the land. This is called *subsidence*. Sinkholes are an example of this effect.

**This page  
intentionally left  
blank**

# 3

# GROUNDWATER OCCURRENCE

## 3.1 INTRODUCTION

All that water occurs below the surface of the earth is termed as sub-surface water, undergroundwater or simply groundwater. The role of groundwater in sustaining the race of the man on this planet has of late acquired such an importance that presently all big and small countries are giving top priorities to short and long-term schemes, envisaging exploration and exploitation of groundwater reserves in their perspective regions. Groundwater is one portion of the earth's water. Various forms of water always move in natural circulation system, known as the hydrologic cycle.

Seawater because of sun's heat evaporates to the atmosphere, and by the wind it's blown to the above of land. In a high elevation place, these vapors will be compacted and when its saturation point is exceeded, it falls again to the earth as rainwater. Most part of rainwater flows at surface as surface water, such as rivers, lakes, or swamps. A small portion of rainwater infiltrates into soil and percolates to reach saturated zone and joins groundwater. Part of water, which infiltrates near surface, will evaporate again through plants (evapotranspiration). Direct evaporation lasts on opened water body, whilst surface run-off will eventually gather back to the sea, and hydrological process as mentioned above, will last over and over again.

Hydrogeology may be defined as the science of the occurrence, distribution and movement of water below the surface of the earth, with emphasis on geology.

## 3.2 GROUNDWATER OCCURRENCE

Groundwater is part of water below surface (sub-surface water), in zone of saturation (Figs. 3.1 and 3.2). Vertical distribution of sub-surface water may be divided into zone of aeration and saturated zone. Zone of aeration comprises of interstices, which are partly occupied with water, and air, while all interstices in saturated zone is filled only with water. Water fills in zone of aeration is called as vadose water. Vadose water, which occurs near surface and available for roots of vegetation, is defined as solumn water. It is also called zone of non-saturation and starts from the surface extending to different depths. In this zone, the open spaces between the soil particles and rock spaces never get completely filled with water. Groundwater in this zone is under a perpetual downward movement mainly under the influence of gravity. Water in this zone is under no hydrostatic head. Within this zone, a thin belt of soil — water is

sometimes also distinguished which comprises uppermost thickness of the ground in which some water is held-up while percolating downwards by the root zone of vegetable cover and some chemicals. This water is then easily lost to the atmosphere through transpiration.

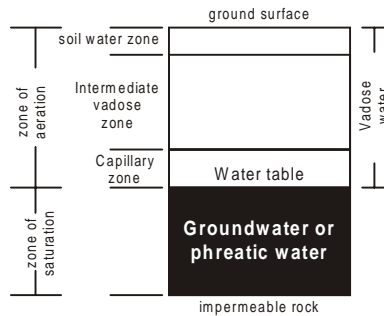

Fig. 3.1 Distribution of subsurface water.

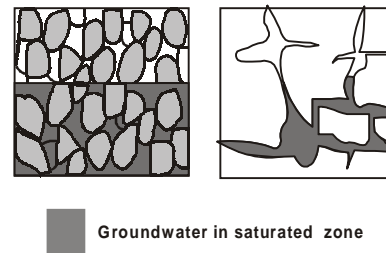

Fig. 3.2 Water in saturation zone.

The Capillary water is the water occupies capillary zone and is observed at the boundary between the zone of saturation and zone of aeration. Capillary fringe is characteristic of fine-grained sediments in which the water may rise much above the main water level of the zone of saturation. Groundwater occurs in saturated zone filled in all rock interstices or fissures (Fig. 3.2). In many cases a significant rise and fall in the level of this zone is observed as a characteristic feature during different part of the year. Since in this zone all the openings are completely filled with water, there is no or very little downward movement. The predominant movement is a type of flow and is controlled by the head of the water.

A third zone of intermittent saturation is then easily recognized which marks the depths between the zone of aeration and zone of saturation.

### 3.3 SOURCE OF GROUNDWATER

Almost all groundwater can be thought of as a part of the hydrologic cycle and is derived from one of the following sources:

**Meteoric Water:** (or the water derived from precipitation). Although great part of the rain water reaches the sea through surface flows or run-off, a considerable part of water falling on the surface in the form of precipitation infiltrates or percolates downwards, below the surface and forms the groundwater. Most of the water obtained from underground supplies belong to this category. The infiltration of rain water and melted water starts immediately after the water reaches the ground, and may also take place from surface water bodies such as rivers, lakes and sea, in an almost continuous process.

**Connate Water:** Water that has been out of contact with the atmosphere for at least an appreciable part of a geological period is termed as connate water. It consists of fossil interstitial water that has migrated from its original burial location. This water may have been derived from oceanic or fresh water sources and, may be, is highly mineralized. Many important sedimentary rocks, like limestone, sandstone are deposited and consolidated under water.

Although compaction might squeeze out most of the water initially present in the pores between grains, yet some water might still be retained in the inter-granular spaces of such rocks. It is however, of not much importance in yielding supplies for human consumption.

**Juvenile Water:** It is also called magmatic water. This water is derived from magma; where the separation is deep, the term plutonic water is applied, while volcanic water is derived from relatively shallow depth (3 km to 5 km). New water of magmatic or cosmic origin that has not previously been a part of the hydrosphere is referred to as juvenile water.

### 3.4 FACTORS CONTROLLING GROUNDWATER

**Rainfall:** The amount of rainfall in any area plays an important role in determining the groundwater. It is estimated that about 5 cm rainfall in one hour facilitates more run-off and results in less filtration. Contrarily, a rainfall of about 5 cm in 24 hours creates fewer run-offs and more filtration. However, much depends on other factors such as topography, vegetation, evapotranspiration and water bearing properties of rocks and soils and their nature.

**Topography:** this effects run-off and filtration. Steep slope of ground activates more run-off water and less filtration. In another situation, a gentle slope region facilitates more or less equal run-off and filtration. In horizontal ground, the run-off will be minimal and consequently filtration increases, adding more filtrated water to the subsurface water.

**Vegetation cover:** Vegetation intercepts much of the rainfall and has an effect on the recharge of groundwater. If vegetation is very less or absent, this results in more run-offs and less filtration. However, when thick vegetation cover is covered with grassland, filtration is more in the grassland than in the thick cover forest. Thick cover vegetation also intercepts much of the rainfall and reduces the recharge.

**Evapotranspiration:** Evaporation is caused by the action of solar radiation and wind, which evaporates water molecules from such surface bodies as rivers, lakes, reservoirs etc. This process may also be affected to a depth of 1 to 2 meters below the soil zone. All plants transpire water through their green leaves and take less water from the shallow water bearing formations. The rate of transpiration depends on the atmospheric temperature and velocity of wind. The combined process of evaporation and transpiration is commonly referred to as Evapotranspiration.

**Water bearing properties of rocks and soils:** Water bearing properties such as porosity, permeability, fissures, jointing, types of rocks etc play an important role in groundwater formation. Highly porous and permeable rock or soil facilitates more recharge. Water bearing properties play an important role in the circulation of groundwater.

### 3.5 WATER BEARING PROPERTIES OF SOILS AND ROCKS

**Porosity:** Porosity, a water bearing property, is the percentage ratio of volume and voids to the

total volume of rock or soil. It can be expressed as:  $n = \frac{V_v}{V} \times 100$ , where n is porosity,  $V_v$  is volume of voids and V is total volume.



During natural formation of rock pores, voids and interstices develop. Such originally developed porosity is known as *original porosity or primary porosity*. Sedimentation and crystallization of igneous rocks and the flocculation process in clay are responsible for the formation of primary porosity. Secondary porosity is developed due to weathering and fracturing of rocks, metamorphism, chemical reaction, biological processes such as animal and insect burrowing, penetration of root system into the soil or rock layers etc. Grain size, shape, roundness and angularity influence porosity. Uniform grain size provides considerable pore space whereas poorly sorted grains restrict void space. This results in more porosity in well-sorted grains less in poorly sorted grains. Cemented grains with mineral matter provide very little pore space and consequently reduce porosity. Fractured and jointed blocks provide large spaces for storage of groundwater. Open solution cavities also provide pore space.

However, porosity depends on the arrangement, shape and size of the grains. The average porosities for some common soils and rocks are listed in Table 3.1.

**Table 3.1 Average porosities of some common rocks and soils**

<i>Rock / Soil</i>	<i>Average Porosity (%)</i>
Soils	50 – 60
Clay	45 – 55
Silt	40 – 50
Mixture of sand	35 – 40
Uniform sand	30 – 40
Gravel	30 – 35
Cavernous limestone	25 – 35
Sandstone	10 – 20
Vesicular basalt	5 – 10
Shale	1 – 10
Limestone	1 – 10
Crystalline massive granite, Gabbros, Gneisses, etc	1 – 3

In other words, porosity is the capacity of the substance to store subsurface water. Storage of groundwater depends on the porosity of the rocks or soils. All the water stored in the subsurface layers cannot be recovered from wells. Large amounts of water are always retained in the rock due to the peculiar capillary action forming a film around these particles. The volume of water available for draining out from the rocks is known as *specific yield*.

The volume of water retained in the rocks and not available for draining out is termed Specific retention. Hence, the effective porosity = specific yield + specific retention. These parameters of rocks or soils are determined with pumping and recovery tests from wells in the area.

**Permeability and Transmissibility:** Permeability is defined as the capacity to transmit water and other fluids through a unit section in a unit time under a hydraulic gradient. It is also called the *hydraulic conductivity*. In other words, it is the velocity of percolation. For practical work in groundwater hydrology, where water is the prevailing fluid, hydraulic conductivity =  $k$  is employed. The rate of hydraulic conductivity depends on the degree and nature of arrangement of grains from coarse to fine. For example, well-sorted materials of larger grain size have a high hydraulic conductivity and permit the flow of large quantities of water or other fluids.

A medium has a unit hydraulic conductivity if it transmits in unit time a unit volume of groundwater at the prevailing kinematic viscosity through a cross-section of unit area measured at right angles of direction of flow under a unit hydraulic gradient ( $dh/dl$ ).

$$k = -v/(dh/dl) = (m/day)/(m/m) = m/day.$$

Where  $v$  = velocity of specific discharge (the negative sign indicates that the flow of water is in the direction of decreasing head).

Hydraulic conductivity of geologic materials depends on a variety of physical factors including porosity, particle size and distribution, shape of particles, arrangement of particles, and other factors. A rock formation has hydraulic conductivity  $k$  and saturated thickness  $b$ , then it has *transmissibility coefficient*,  $T = K \times b = (m/day) \times (m) = m^2/day$

Transmissibility may be defined as the rate at which water of prevailing kinematic viscosity is transmitted through a unit width of aquifer under a unit hydraulic gradient.

The higher value of  $T$  is meant that lithology of rock is an aquifer with high potential groundwater.

The representative values of physical parameters associated with various types of aquifer materials are shown in Table 3.2.

**Table 3.2 Representative values of physical parameters associated with various types of aquifer materials.**

<i>Material</i>	<i>Porosity (%)</i>	<i>Specific Yield (%)</i>	<i>Hydraulic Conductivity (m/day)</i>
Coarse Gravel	28'	23	150'
Medium Gravel	32'	24	270'
Fine Gravel	34'	25	450'
Coarse Sand	39	27	45'
Medium Sand	39	28	12'
Fine Sand	43	23	2.5'

*Contd.*

<i>Material</i>	<i>Porosity (%)</i>	<i>Specific Yield (%)</i>	<i>Hydraulic Conductivity (m/day)</i>
Silt	46	8	0.08 <sup>h</sup>
Clay	42	3	0.0002 <sup>h</sup>
Fine-grained sandstone	33	21	0.2 <sup>v</sup>
Medium-grained sandstone	37	27	3.1 <sup>v</sup>
Limestone	30	14	0.94 <sup>v</sup>
Dolomite	26		0.001 <sup>v</sup>
Dune sand	45	38	20
Loess	49	18	0.08 <sup>v</sup>
Peat	92	44	5.7 <sup>v</sup>
Schist	38	26	0.2 <sup>v</sup>
Shale	6		
Slate			0.00008 <sup>v</sup>
Till (predominantly silt)	34	6	
Till (predominantly sand)	31	16	0.49 <sup>r</sup>
Till (predominantly gravel)		16	30 <sup>r</sup>
Tuff	41	21	0.2 <sup>v</sup>
Basalt	17		0.01 <sup>v</sup>
Weathered gabbro	43		0.2 <sup>v</sup>
Weathered granite	45		1.4 <sup>v</sup>

*v* - indicates vertical measurement of hydraulic conductivity,

*h* - indicates horizontal measurement of hydraulic conductivity,

*r* - indicates measurement on a repacked sample

Water bearing properties such as porosity, specific retention and hydraulic conductivity play important roles in the movement of subsurface water. Depending on their water bearing properties, rock materials are classified as aquifers or water bearing and yielding formations.

### 3.6 TYPES OF AQUIFERS

Aquifer is a formation that contains sufficient saturated permeable material to yield significant quantities of water to wells or springs. This implies an ability to store and transmit water. Unconsolidated sands and gravels are a typical example. Synonyms frequently employed include: water bearing formation and groundwater reservoir.

Most aquifers are of large areal extent and may be visualized as underground storage reservoirs. Water enters a reservoir from natural or artificial recharge. There are various types of aquifers:

**Unconfined aquifer:** is a water-bearing layer where its water table is upper boundary of aquifer itself. Groundwater in this aquifer type is called as unconfined or free groundwater, since water pressure is equal to air pressure (Fig. 3.3). In unconfined aquifer, a water table varies in undulating form and in slope, depending on areas of recharge and discharge.

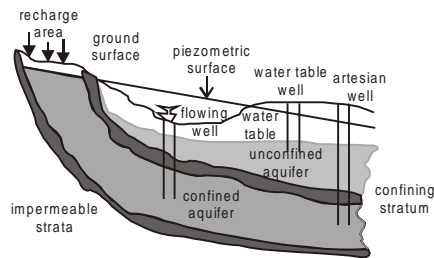

Fig. 3.3 Types of aquifers.

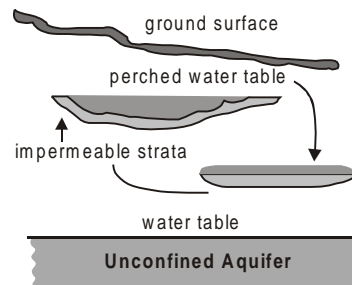

Fig. 3.4 Perched aquifers.

**Confined aquifer:** is water-bearing layer, where groundwater is confined under impermeable strata, both at its upper and basement. Water level lies higher than the upper part of aquifer (Fig. 3.3). Water level, in this case is called as piezometric, may be at above or below surface. If piezometric head lies above surface, then a well, which taps this type of aquifer flowing freely from groundwater to the surface. Groundwater in such condition is termed as artois or artesian. Based on its confining layer, confined aquifer may be distinguished to semi-confined aquifer or fully confined.

**Perched aquifer:** a special case occurs wherever a groundwater body is separated from the main groundwater by a relatively impermeable stratum of small extent, and lying above the main groundwater table (Fig. 3.4).

**Leaky aquifer:** Aquifers that are completely confined or unconfined occur less frequently than do leaky aquifers occur. These are common feature in alluvial valleys, plains, or former lake basins where a permeable stratum is overlain or underlain by a semi-pervious aquitard, or semi-confining layer. Pumping from a well in a leaky aquifer removes water in two ways: by horizontal flow within the aquifer and by vertical flow through the aquitard into the aquifer.

**Aquiclude:** a saturated but relatively impermeable material that does not yield appreciable quantities of water to wells. Clay is an example.

**Aquifuge:** a relatively impermeable formation neither containing nor transmitting water; solid granite belongs to this category.

**Aquitard:** a saturated but poorly permeable stratum that impedes groundwater movement and does not yield water freely to wells, but that may transmit appreciable water to or from

adjacent aquifers and, where sufficiently thick, may constitute an important groundwater storage zone; sandy clay is an example.

### 3.7 AQUIFER'S LITHOLOGY

Many types of formations serve as aquifers. A key requirement is their ability to store water in the rock/alluvium pores. Porosity may be derived from inter-granular spaces or from fractures. The role of various geological formations as aquifers is briefly described below.

**Alluvial deposits:** The deposits, which are derived as a result of erosion process from older rocks. These deposits comprise of unconsolidated materials, such as sand and gravel (Figs. 3.5 and 3.6). Groundwater occupied rock interstices, and distributed over flat or plain areas. Probably 90 percent of all developed aquifers consist of unconsolidated rocks. The aquifers are recharged chiefly in areas accessible to downward percolation of water from precipitation and from seasonal streams.



**Fig. 3.5 Pores between grains.**  
A very unusual stack of very large rounded boulders left by Pleistocene glaciers. The lack of sediment or cement between grains allows groundwater to pass through the pores more easily.

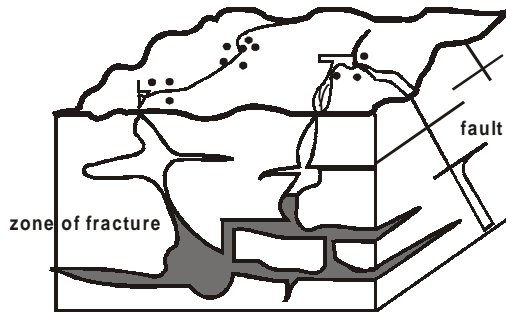

**Fig. 3.6 Colluvium - boulders and cobbles mixed with sand and mud in a debris flow deposit.** Very porous sediment that can transmit a lot of groundwater, but the mud and sand fill the pores and make the rate of water flow, slow.

**Young volcanic deposits:** are deposits of volcanic product, consist of unconsolidated and consolidated materials. Groundwater fills in either interstices of unconsolidated materials or fissures of consolidated rocks. These deposits are distributed adjacent to volcano areas.

**Limestone:** is originally marine deposit with carbonate contents, which due to geologic process is being uplifted to the surface. Here, groundwater occurred in fissures, cavities and solution channels (Figs. 3.7, 3.8 and 3.9). This rock crops out in areas where formerly, there was sea. Owing to geologic, physical and chemical processes, in several areas it formed a particular morphology, known as *karst*. Limestone varies widely in density, porosity, and permeability, depending on degree of consolidation and development of permeable zones after deposition. Openings in limestone may range from microscopic original pores to large solution caverns forming subterranean channels sufficiently large to carry the entire flow of a stream.

**Sandstone:** sandstone and conglomerate are cemented forms of sand and gravel. These sedimentary rocks show great variation in their water yielding capacity, which is chiefly controlled by their texture and nature of cementing materials. Coarse-grained sandstone with imperfect cement may prove as excellent aquifers (fig. 3.10).



**Fig. 3.7** Groundwater occurrence in limestone aquifer.



**Fig. 3.8** Spring discharging groundwater directly into stream, a common occurrence in limestone terrain.



**Fig. 3.9** Solution by acidic water flowing along cracks and bedding planes enhances the permeability of limestone beds.



**Fig. 3.10** Cement between grains decreases the permeability of sedimentary rocks, compared to non-cemented sediments.

**Igneous rocks:** igneous rocks are either intrusive or extrusive in nature. The intrusive igneous rocks are dense in texture with all the component minerals very closely knitted so that very little interstices are left. These would be barren of groundwater under normal conditions, but sometimes fissures and cracks capable of holding some reserves traverse them. The extrusive rocks exhibit great variation in their water bearing properties. The composition of rocks and their mode of formation from lava as well as the nature of the original topography are factors, which generally define the water bearing capacity of these rocks (Figs. 3.11 and 3.12).

**Metamorphic rocks:** metamorphic rocks behave as poor sources and sites for wells unless joints and other cracks traverse these on a large scale. Metamorphic rocks like schist; shale and gneisses, which are often foliated and highly fractured, may prove exceptionally good aquifers.

But marble and quartzite are normally almost impermeable except along original bedding if the same is not completely destroyed during metamorphism.



**Fig. 3.11** Columnar joints (vertical) and lava tubes form in many basalt flows and make these geologic formations very permeable.

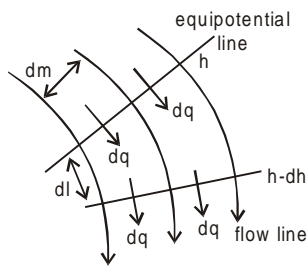

**Fig. 3.12** Cracks, both horizontal and vertical, are common in massive igneous and metamorphic rocks. Areas with many of these fractures can pass a great deal of groundwater.

### 3.8 GROUNDWATER FLOW

Factors which influence the movement of water below surface are, energy difference in level of groundwater itself, permeability of aquifer and, viscosity of groundwater.

Groundwater needs energy to move through interstices. The source of movement is a potential energy. The potential energy of groundwater is reflected by phreatic/piezometric head at given place. Groundwater flowing from higher potential energy points towards lower potential energy points; there are no groundwater flows between points, which have same potential energy. Imaginary line connecting points, which have same potential energy, is known as groundwater contour line or isohypse line. There is no groundwater flows along the contour line since groundwater flows is perpendicular to contour line (Fig. 3.13).



**Fig. 3.13** Groundwater flow net.

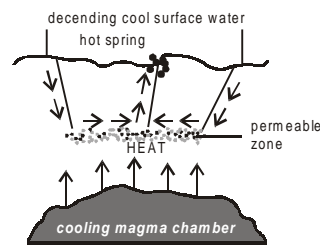

**Fig. 3.14** A thermal spring system.

Groundwater flow generally moves from recharge to discharge area and might appear to the surface due to various factors.

### 3.9 GROUNDWATER APPEARING ON SURFACE

Groundwater may appear naturally to the surface as a spring or because of man activity through wells.

**Spring:** A spring is a concentrated discharge of groundwater appearing at the ground surface as a current of flowing water. Referring to its cause of appearing, springs may be divided into two categories (Todd, 1980), which are: (i) those resulting from non-gravitational forces, and (ii) those resulting from gravitational forces.

Under the former category are included springs, resulting from fractures extending to great depths in the earth's crust. Such springs are usually thermal (Fig. 3.14).

Gravity springs result from water flowing under hydrostatic pressure. The following general types are recognized as shown in Figure 3.15.

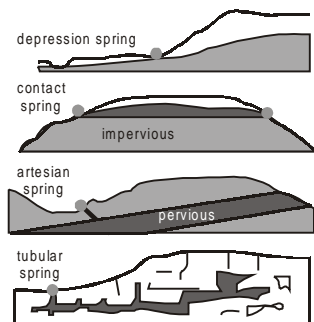

Fig. 3.15 Types of gravity spring.

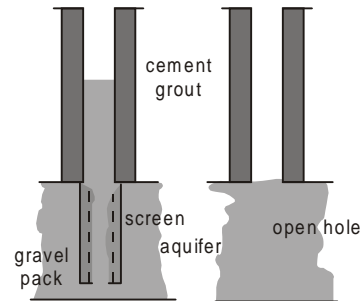

Fig. 3.16 Examples of well formations.

Depression springs formed where ground surface intersects the water table. Contact springs created by a permeable water-bearing formation overlying a less permeable formation that intersects the ground surface. Artesian spring resulting from releases of water under pressure from confined aquifers either at an outcrop of the aquifer or through an opening in the confining bed. Tubular or fracture springs issuing from rounded channels, such as lava tubes or solution channels or fractures in impermeable rock connecting with groundwater.

**Wells:** Groundwater appearing to the surface resulting from human activity may be conducted with fully penetrated or partially penetrated to the aquifer's thickness. Construction of well depends on aquifer's properties and quality of groundwater. Therefore, there are various types of well formation (Fig. 3.16).

Shallow wells are generally less than 15m in depth and are created by digging, boring, driving, or jetting.

**Dug wells:** From ancient times, dug wells have furnished countless water supplies throughout the world. Depths range up to 20 m or more, depending on the position of the water table. Dug wells can yield relatively large quantities of water from shallow sources of unconsolidated glacial and alluvial deposits. In the past all dug wells were excavated by hand, and even today the same method is widely employed. A modern dug well is permanently lined with a casing of



wood staves, bricks, rock, concrete or metal. A properly constructed dug well penetrating a permeable aquifer can yield 2500 to 7500 m<sup>3</sup>/day, although most domestic dug wells yield less than 500 m<sup>3</sup>/day.

**Bored wells:** Where a water table exists at a shallow depth in an unconsolidated aquifer, bored wells can furnish small quantities of water at minimum cost. Bored wells are constructed with hand operated or power driven earth augers. Hand bored wells seldom exceed 20 cm in diameter and 15 m in depth. Power driven augers will bore holes up to 1m in diameter and, under favourable conditions, to depths exceeding 30 m.

**Driven wells:** A driven well consists of a series of connected lengths of pipe driven by repeated impacts into the ground to below the water table. Water enters the well through a drive point at the lower end of the well. This consists of a screened cylindrical section protected during driving by a steel cone at the bottom. Diameters of driven wells are small, most falling in the range of 10-15cms. Most depths of the wells are less than 15 m although a few exceed 20 m. As suction type pumps extract water from driven wells, the water table must be near the ground surface if a continuous water supply is to be obtained. Yields from driven wells are small, with discharges of about 100 – 250 m<sup>3</sup>/day.

**Jetted wells:** Jetted wells are constructed by the cutting action of a downward direction stream of water. Small diameter holes of 3 to 10 cm are formed in this manner to depths greater than 15 m. Jetted wells have only small yields and are best adapted to unconsolidated formations.

**Horizontal wells:** Subsurface conditions often preclude groundwater development by normal vertical wells. Such conditions may involve aquifers that are thin, poorly permeable, or underlain by saline water. In other circumstances, where groundwater is to be derived primarily from infiltration of stream flow, a horizontal well system may be advantageous. Infiltration galleries and collector wells are under the category of horizontal well. An infiltration gallery is a horizontal conduit for intercepting and collecting groundwater by gravity flow. Galleries normally constructed at the water table elevation, discharge into a sump where a pump lifts the water to ground surface for use. Collector wells are normally constructed to draw water for cities and industries located near rivers. Groundwater pumped from collector wells tapping permeable alluvial aquifers has often proved to be a successful solution. If located adjacent to a surface water source, a collector well lowers the water table and thereby induces infiltration of surface water through the bed of the water body to the well. In this manner, greater supplies of water can be obtained than would be available from groundwater alone. The large area of exposed perforations in a collector well causes low inflow velocities, which minimize incrustation, clogging, and sand transport. Polluted river water is filtered by its passage through the unconsolidated aquifer to the well. Yields vary with local conditions; the average yield for a large number of such wells approximate 27,000 m<sup>3</sup>/day. Collector wells can also function in permeable aquifers removed from surfacewater. Several such installations gave an average yield of about 15,000 m<sup>3</sup>/day.

In order to know about the discharge of well, pumping test should be conducted. Its principles are to pump out groundwater from a well with a certain constant discharge and observe

drawdown of groundwater level during pumping (Fig. 3.17). From the result of observation specific capacity of well are known — a volume of water which is resulted, in a unit volume if water level in well is declining in a unit length (for example liter/second per meter drawdown). Apart from that, pumping test may calculate aquifer's parameters such as hydraulic conductivity value. Groundwater drawdown in a single well is different with drawdown of multiple wells. Drawdown in multiple wells will influence between each other, depends on wells' distance (Fig. 3.18).

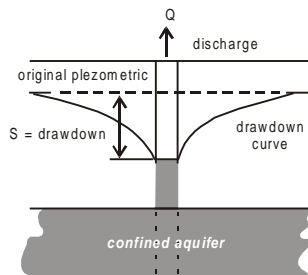

Fig. 3.17 Effect of pumping test.

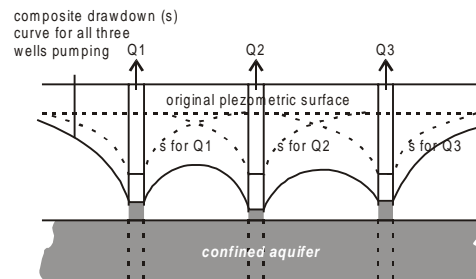

Fig. 3.18 Drawdown effect on multiple wells pumping.

In an area where many wells tap the groundwater from the same aquifer, pumping will form a cone of depression. If it happens in a coastal area, seawater encroachment may occur — brackish or saline water flows to the land. Meanwhile, if this condition lasted in a confined aquifer with clay layer as its confining bed, a land subsidence potentially occurs.

### 3.10 GROUNDWATER EXPLORATION

Groundwater is one of the earth's most widely distributed replenishable resources. Groundwater caters to the requirements of the agricultural, domestic and industrial sectors. The total groundwater on the earth is 35 times greater than the surface water. Subsurface water is available in appreciable quantities over surface water, but sometimes we are not able to tap this groundwater resource. The reason is non-uniform distribution of groundwater resources. The movement and availability of water is mainly controlled by aquifer parameters. The composition and lithological variation of the earth differ in subsurface layers depending on various factors.

The main objective of groundwater exploration is to locate aquifers capable of yielding water in sufficient quantity of suitable quality for domestic, industrial and agricultural purpose. To estimate various parameters of groundwater resources for long term, following scheme of investigations are normally undertaken:

**Remote sensing studies:** Satellite-based data provide quick and useful baseline information on the factors controlling the occurrence and movement of groundwater. A systematic study and interpretation of satellite imageries lead to better delineation of perspective groundwater zones in a region. Such perspective zones identified from the satellite imageries are followed upon the ground through detailed hydrogeological and geophysical investigations before actual drilling is carried out for exact assessment about potential site. The usefulness of satellites data in

identifying linear features, such as lineaments representing fractures, faults, shear zones, which are usually the zones of localization of groundwater and certain geomorphic features such as alluvial fans, valley fills, palaeo-channels etc. often form good aquifers as well established perspective groundwater zones in a region.

**Topographical survey:** In this survey, surface map is prepared and grid lines are laid on the ground and reduced levels are determined for each of the grid points.

**Hydrogeological studies:** In this survey, response of rainfall pattern is studied on water level fluctuation and total quantity added annually by rainfall in the upper unconfined aquifer is computed. The Central Groundwater Board, Ministry of Water Resources has published a hydrogeological map of India. This map illustrates the overall hydrogeological parameters of the region. The occurrence and abundances of groundwater in a given terrain mainly depends on the water holding capacity of the lithological types and their associated structural features, which enable the rocks to allow the surface water to percolate and accumulate in the subsurface horizons. The distribution of groundwater directly depends on the nature of vertical and lateral extent of rock types, their interconnected structural elements and the weathered profile capable of yielding percolation of surface and subsurface water. In hydrogeological investigation well inventory plays a vital role. Well inventory studies provide information on groundwater conditions of an area than do other hydrogeological aspects. A well inventory study includes the dimensions of existing wells, soil type, lithology, structural features, water level fluctuations, depth of wells, length of water column, mode of extraction of water, quality of water etc. A hydrogeological map of given area is to be prepared on the basis of such hydrogeological factors as surface water bodies, their distribution and extent, available well inventory details and water table contours. Aquifers are to be delineated with reference to the water table, lithological contacts, extent and attitudes of structural features etc., recharge and discharge basins of groundwater. These studies are carried out in order to ascertain the success of water supply project dependent upon the aquifers traced by geological and geophysical investigations. The study involves an evaluation of:

- (i) Quantity of water that the aquifer in question receives from different sources in given periods.
- (ii) The porosity, thickness and width of aquifer.
- (iii) The permeability parameters of the aquifer which are necessary for defining the rate of flow of water through the ground, and the quantity of water lost from the aquifer to other formations through seepage, springs and by evaporation and transpiration.
- (iv) The scope for recharge or replenishing the aquifers through natural and artificial methods and economics involved in the same.

**Geophysical survey:** Geophysical investigations play an important role in hydrogeological studies. These are most successful when used in combination with geological methods. Geophysical investigations are usually carried out after studying the geology and hydrogeology of an area. They are employed to understand the nature of the subsurface, lithology, thickness and depth of the water bearing horizons. Electrical, magnetic, induced polarization, seismic magnetic and gravity methods are the most important geophysical methods used in exploration.

These methods make use of the physical properties of electrical conductivity, magnetic susceptibility, elasticity and density. These physical properties differ depending on the rock type, structure, and degree of water saturation, physical, chemical and mineralogical changes. Electrical methods are extensively used for the exploration of subsurface water.

Geoelectric monitors are deployed to evaluate electrical properties of the aquifer system leading to determination of saturated thickness in subsurface. In this method, electrodes are inserted in the ground and connected in a circuit to a source of electrical energy. Under such circumstances, current flows from one electrode, passes through the ground and leaves through the other electrodes. The depth to which the current penetrates depends upon the distance between the two outer electrodes. Thus, it makes penetration to great depths possible by increasing the spacing between the electrodes. The variations in the value of resistivity with depth are plotted. The resistivity curves thus obtained are then interpreted for the presence of water. For accurate interpretation, however, detailed knowledge of stratification is very necessary. The range of resistivity generally encountered in various soils and rocks is given in Table 3.3 hereunder:

**Table 3.3 Resistivity range of various formations**

<i>Material</i>	<i>Resistivity (Ohm-m)</i>
Sand	500 – 1500
Clays, saturated silt	0 – 100
Clayey sand	200 – 500
Gravel	1500 – 4000
Weathered rock	1500 – 2500
Sound rock	>5000

### 3.11 AQUIFER PERFORMANCE TEST

This test is carried out on existing tube wells or new tube wells along with nearby tube well in the zone of influence and groundwater hydraulic parameters are determined for estimating long-term groundwater reserves.

Based on studies mentioned above, total replenishable resources are estimated and water extraction levels are recommended equivalent to rate of recharge. These reserves are available for long term, unless consecutive draughts occur for 3 to 5 years. For such eventualities, static water reserves are estimated and worked out as to how many years, these reserves can sustain in absence of recharge. If static reserves for 3 to 5 years are available, area is suitable for long term withdrawal of water (25 to 50 years); provided withdrawal is limited to rate of dynamic water reserves added by various recharge components annually.

After above comprehensive studies, recommendations are made about yield potential, qualitative and quantitative aspects and extent of utilization of water.

**This page  
intentionally left  
blank**

# 4

# WATER LOSSES

## 4.1 INTRODUCTION

Losses from precipitation in engineering are defined as the quantity which does not yield for irrigation, domestic, water supply and any other such uses. Thus, for a surface water resource engineering the difference between precipitation and runoff in a stream is, a loss which can be taken as the sum of the losses of (i) evaporation, (ii) transpiration, (iii) interception, (iv) depression storage and (v) infiltration. These losses form a major portion of the hydrological cycle. Evaporation is a major loss followed by transpiration and infiltration. Infiltration, which might be a loss to a surface water hydrologist, is a major gain to those dealing with ground water potential and utilization.

$$\text{Precipitation} - \text{Surface runoff} = \text{Total loss (Evaporation + Transpiration + Interception + Depression Storage + Infiltration)}$$

Before the rainfall reaches the outlet of a basin as runoff, certain demands of the catchment such as interception, depression storage and infiltration have to be met. If the precipitation not available for such runoff is defined as **losses**.

## 4.2 EVAPORATION

Many areas of the world are arid or semiarid. The problem caused by the loss of water stored in lakes and reservoirs for irrigation and domestic use by evaporation during summer months is acute and perennial, and the loss is enormous. Table 4.1 shows the estimation of water surface area available for water evaporation control by monolayer films. The evaporation loss of water is of the order of  $1.32 \times 10^{12}$  gallons.

**Table 4.1 Estimation of water surface area available for water evaporation**

Area of arid, semiarid and long dry spell regions of India	2,00,000 sq. km
Estimated water area in these regions (1% of above)	20,000 sq. km
Estimated water area where film application may be feasible (10% of above)	2,000 sq. km
Evaporation loss of water over this per year (Estimated depth of 3 meters)	$6 \times 10^9 \text{ m}^3$ ( $1.32 \times 10^{12}$ gallons)

Evaporation is the process in which a liquid changes to the gaseous state at the free surface, below the boiling point through the transfer of heat energy. Consider a body of water in pond. The molecules of water are in constant motion with a wide range of instantaneous velocities. An addition of heat causes this range and average speed to increase. When some molecules possess sufficient kinetic energy, they may cross over the water surface. Similarly, the atmosphere in the immediate neighbourhood of the water surface contains water molecules within the water vapour in motion and some of them may penetrate the water surface. The net escape of water molecules from the liquid state to the gaseous state constitutes evaporation. Evaporation is a cooling process in that the latent heat of vaporization (at about 585 cal/g of evaporated water) must be provided by the water body. The equivalent molecular weight of air is 28.95 and that of water vapour is 18, i.e., water vapour is 62% lighter than air. This helps water vapour to rise into the atmosphere to a height where it condenses. Importance of evaporation and its potential can be gauged from water budget of continents and oceans (Table 4.2).

**Table 4.2 Evaporation from continents**

<i>Continent</i>	<i>Precipitation (mm/year)</i>	<i>Evaporation (mm/year)</i>	<i>% Loss by Evaporation (mm/year)</i>	<i>Runoff (mm/year)</i>
Africa	690	430	62.3	260
Asia	600	310	51.7	290
Australia	470	420	89.4	50
Europe	640	390	60.9	250
North America	660	320	48.5	340
South America	1630	700	42.9	930
Land area	730	420	57.5	310

**Table 4.3 Average values of losses for North and South India for various months of the year**

<i>Month</i>	<i>Jan</i>	<i>Feb</i>	<i>Mar</i>	<i>Apr</i>	<i>May</i>	<i>Jun</i>	<i>Jul</i>	<i>Aug</i>	<i>Sep</i>	<i>Oct</i>	<i>Nov</i>	<i>Dec</i>
Losses for North India (mm)	70	90	130	160	270	240	180	140	140	130	90	80
Losses for South India (mm)	100	100	180	230	250	180	150	150	150	130	100	100

Average annual rainfall in India is about 1120mm, which is equal to 370 million hectare-m of water. Total runoff by all the rivers of the country is 170million hectare-m. If annual ground water recharge is 37million hectare-m is also lost to atmosphere and transpiration. Part of the 37million hectare-m is also lost to atmosphere as transpiration. The factors affecting evaporation are: (i) vapour pressures at the water surface and air above, (ii) air and water temperature, (iii) wind speed, (iv) atmospheric pressure, (v) quality of water and (vi) size of water body.

### **Factors Affecting Evaporation**

**Vapour pressure:** The rate at which molecules leave the water depends on the vapour pressure of the liquid. Similarly, the rate at which molecules enter the water depends on the water pressure of the air. The rate of evaporation, therefore, depends on the difference between the saturation vapour pressure at the water temperature,  $e_w$  and the actual vapour pressure in the air,  $e_a$ . Thus  $E_L = C (e_w - e_a)$ . Where  $E_L$  = rate of evaporation (mm/day) and  $C$  = a constant;  $e_w$  and  $e_a$  are in mm of mercury. This is known as Dalton's law of evaporation. Evaporation continues till  $e_w = e_a$ . If  $e_w > e_a$  condensation takes place.

**Temperature:** The rate of emission of molecules from liquid water is a function of its temperature. The higher the temperature, the greater the energy of the molecules and the rate of emission. Regarding air temperature, although there is a general increase in the evaporation rate with increasing temperature, a high correlation between evaporation rate and air temperature does not exist. Thus for the same mean monthly temperature, it is possible to have evaporation to different degrees in a lake in different months.

**Wind:** Since turbulence varies with speed, there must necessarily be a relation between evaporation and wind movement. Wind aids in removing the evaporated water vapour from the zone of evaporation and consequently creates greater scope for evaporation. However, if the wind velocity is large enough to remove all the evaporated water vapour, any further increase in wind velocity does not influence the evaporation. Thus the rate of evaporation increases with the wind speed up to a critical speed beyond which any further increase in the wind speed has no influence on the evaporation rate. This critical wind speed value is a function of the size of the water surface. For large water bodies high-speed turbulent winds are needed to cause maximum rate of evaporation.

**Atmospheric pressure:** Other factors remaining same, a decrease in barometric pressure, as in high altitude, increases evaporation. Atmospheric pressure is so closely related to other factors affecting evaporation that it is practically impossible to study the effect of its variations under natural conditions. The number of air molecules per unit volume increases, with pressure. Consequently, with high pressure there is more chance that vapour molecules escaping from the water surface will collide with air molecules and rebound into the liquid. Hence, evaporation would be expected to decrease with increasing pressure. The reduction in pressure with increase in elevation acts to increase evaporation at high elevations. This effect is offset by the general decrease in temperature with elevation and hence the relation between elevation and evaporation is not clearly defined. It has been shown also that evaporation at high altitude is greatly influenced by the orientation of the slope.

**Quality of water:** The rate of evaporation is less for salt water than for fresh water and decreases as specific gravity increases. The evaporation rate decreases about 1 percent for each 1 percent increase in specific gravity until crusting takes place, usually at a specific gravity of about 1.30. Evaporation from seawater has been estimated to be about 2 to 3 percent, less than fresh water when other conditions are the same. Turbidity appears to have noticeable effect on evaporation rate.



**Heat storage in waterbodies:** Deep-water bodies have more heat storage than shallow ones. A deep lake may store radiation energy received in summer and release it in winter causing less evaporation in summer and more evaporation in winter compared to a shallow lake exposed to a similar situation. However, the effect of heat storage is essential to change the seasonal evaporation rates and the annual evaporation rate is seldom affected. Different evaporating surfaces like soil, barren land, forest area, houses and lakes affect evaporation to the extent they have the potential. Black cotton soils help to evaporate the soil water faster than red soil because such soils have the potential to absorb incoming radiation more effectively. Evaporation from wet soil is faster and it reduces gradually as soil becomes drier.

### Measuring Evaporation

It is rather impossible to measure evaporation directly in the field. Evaporation from water surface is estimated by different methods and its values are correlated to field data. While estimating evaporation from open storages, it is necessary to know seepage that occurs from the bed of the reservoir. Not much information about the determination of loss of water from storages that can be attributed solely to seepage from the bed and slides is available. In India, attempts have been made to develop seepage meters. A seepage meter (Fig 4.1) developed by the Irrigation Research Institute, Poondi, Chennai, was installed in the deeper section of Buderu Tank and seepage loss through its bed measured. The device consists of two cylindrical pans, 1.2294m diameter and 0.43m high with a hole of 38.10mm diameter in the center and short metal pipes of about 101.60mm in length welded to the holes to project outside from the bottom. The later pipes serve to connect the pans to each other with the help of a rubber hose. One of the pans is inverted and rammed into the bed such that at least 228.60mm of its sides penetrate into the soil, the other pan with its open end facing upwards is supported on a framework above first pan with its bottom at least 228.60mm below the water surface of the tank. The top pan is covered by a lid to prevent loss of water due to evaporation, and water is poured into it to the same level as that in the tank on the outside of it. When the water from the bottom pan seeps through the bed of the tank, the water level in the top pan gets lowered correspondingly and thus serves to indicate directly the loss of water due to seepage from the tank bed. It has been reported that consistent values could not be obtained.

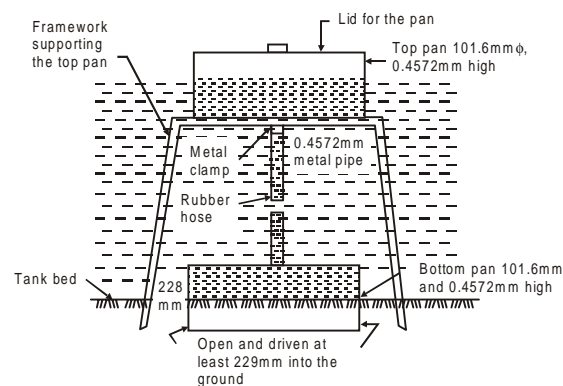

Fig. 4.1 Seepage meter (IRI, Poondi, Chennai).

At the Irrigation Research Institute, Roorkee, attempts were made to improve the seepage meter developed by Regional Salinity Laboratory, Soil Conservation Service Riverside, California, by replacing the plastic bag by a constant head vessel (Fig. 4.2) to measure seepage in channels. The seepage meter essentially consists of seepage cup, constant head vessel and swivel head joint. The seepage meter before use was standardized. The value obtained by a seepage meter is to be multiplied by a coefficient greater than one for less pervious soil and less than one for more pervious soils.

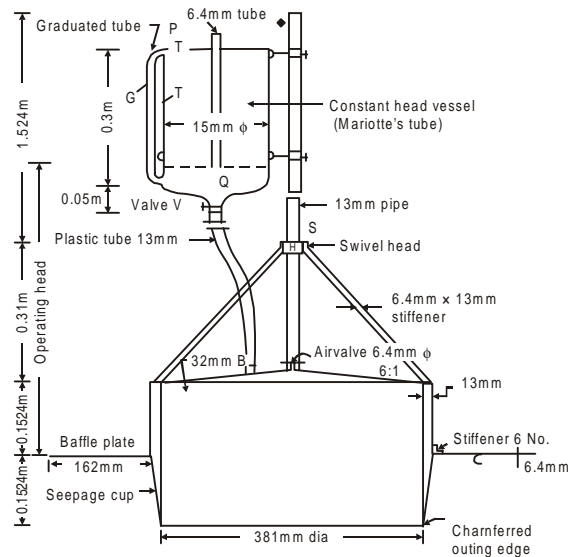

Fig. 4.2 Seepage meter (IRI, Roorkee).

The methods available to estimate evaporation losses from surfaces of large water bodies are:

1. Evaporation pans
2. Empirical equations
3. Water balance method
4. Energy budget method
5. Mass transfer method

**1. Evaporation Pans:** Evaporation measurement using pans is the most reliable and the best of all the available methods. An evaporimeter as specified by IS: 5973 – 1970 for Indian conditions is a pan of 1.22m in diameter and 0.255m deep. It is a modified version of the US Weather Bureau class A pan since the latter is made of galvanized iron and is not painted white outside. The Indian Standard pan is made up of 0.90mm thick copper sheet with hexagonal wire netting of galvanized iron mesh covering it to protect its water from birds. The details of IS specified pan are given in Fig. 4.3. The pan is placed over a wooden platform of 10cm height so that circulation of air is possible all around the pan. This also helps to thermally insulate the

pan completely from ground. Water level in the pan is recorded by a point gauge arrangement placed inside a stilling basin. Normally, an evaporation pan is placed along with other weather measuring instruments for recording humidity, temperature, rainfall, wind speed and other parameters. Measurement is taken at least once a day by adding water to the pan by a calibrated cylindrical glass jar to bring the water level to the previous position. This gives directly the evaporation depth over the time lapse. If there is rainfall exceeding the depth of evaporation, then water is taken out of the pan in the same way by the measuring jar and knowing the depth of rainfall from the rain gauge the evaporation depth is found out by subtraction.

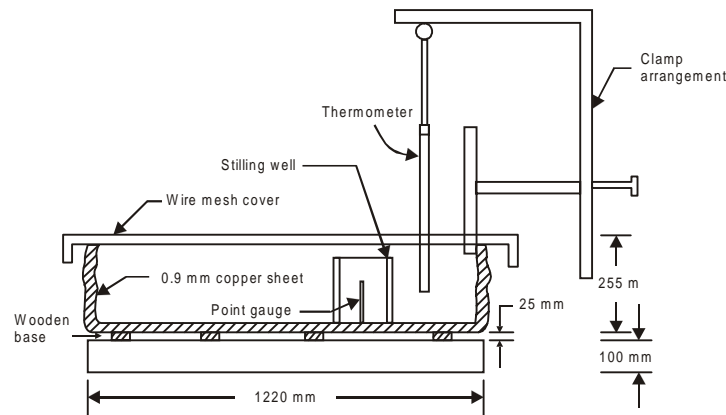

Fig. 4.3 IS specified evaporation measuring pan.

**US Weather Bureau Class A Land Pan** – It is standard pan of 1210mm diameter and 255mm depth. The depth of water is maintained between 18cm and 20cm (Fig. 4.4). The pan is normally made of unpainted galvanized iron sheet. The pan is placed on a wooden platform of 15cm height above the ground to allow free circulation of air below the pan. Measuring the depth of water with a hook gauge in a stilling well makes evaporation measurements.

**Colorado Sunken Pan** – This pan, 920mm square and 460mm deep is made up of unpainted galvanized iron sheet and buried into the ground within 100mm of the top (Fig. 4.5). The chief advantage of the sunken pan is that radiation and aerodynamic characteristics are similar to those of a lake.

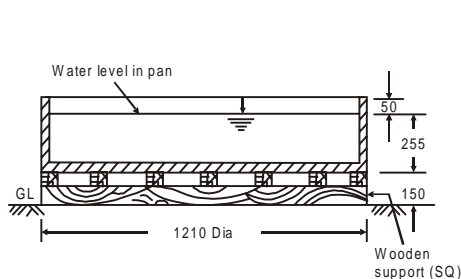

Fig. 4.4 US Weather Bureau Class A Land Pan.

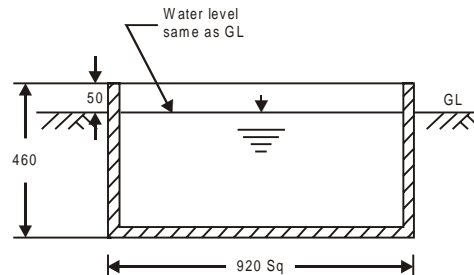

Fig. 4.5 Colorado Sunken Pan.

**US Geological Survey Floating Pan** – With a view to simulate the characteristics of a large body of water, this square pan (900mm side and 450mm depth) supported by drum, floats in the middle of a raft (4.25m × 4.87m) is set afloat in a lake. The water level in the pan is kept at the same level as the lake leaving a rim of 75mm. Diagonal baffles provided in the pan to reduce the surging in the pan due to wave action. Its high cost of installation and maintenance together with the difficulty involved in performing measurements are its main disadvantages.

Evaporation recorded by a pan differs from that of a lake or reservoir due to: (i) depth of exposure of pan above ground, (ii) colour of the pan, (iii) height of the rim, (iv) heat storage and heat transfer capacity with respect to reservoir, (v) pan diameter, (vi) variation in vapour pressure, wind speed and water temperature. The evaporation recorded by the pan has to be reducing to that of the lake or reservoir by multiplying a pan coefficient between 0.60 and 0.80.

$$\text{Lake evaporation} = \text{Pan coefficient} \times \text{Pan evaporation}$$

A relation between pan diameter and ratio of pan evaporation to lake evaporation is given in Table 4.4.

**Table 4.4 Relation between pan diameter and pan coefficient to convert to lake evaporation**

Pan diameter (m)	4.0	3.0	2.0	1.5	1.0	0.5	0.1
Ratio of pan evaporation to evaporation from lakes of 7.3 km <sup>2</sup>	1.16	1.18	1.21	1.28	1.33	1.45	1.80
Pan coefficient	0.86	0.85	0.83	0.78	0.75	0.70	0.56

Lake evaporation is used as the potential value for computation of crop water requirement by climatic approach. Evaporation from lake is considered the same as that of a saturated soil covered with vegetation.

#1 Annual pan evaporation from an observatory is 150 cm. The reservoir water spread area varies from a maximum of 12.5 sq.km in the beginning of January to a minimum of 4.2 sq.km in May and is back to a level of 12.5 sq. km at the end of December. Calculate loss of water from the reservoir during the year. Assume pan coefficient as 0.83.

**Solution:** Mean area of water spread is computed by cone formula as:

$$A_m = \frac{1}{3} \times \frac{5}{12} \{A_1 + A_2 + (A_1 A_2)^{0.5}\} + \frac{1}{3} \times \frac{7}{12} \{A_1 + A_2 + (A_1 A_2)^{0.5}\}$$

$$A_m = \frac{1}{3} \times \frac{5}{12} \{12.5 + 4.2 + (12.5 \times 4.2)^{0.5}\} + \frac{1}{3} \times \frac{7}{12} \{(12.5 \times 4.2)^{0.5}\}$$

$$A_m = 3.326 + 4.656 = 7.982 \text{m}^2$$

Therefore, annual volume of water lost from the reservoir assuming a pan coefficient of 0.83 is calculated as:  $V_1 = (7.982 \times 10^6 \text{ m}^2) \times \left(\frac{150}{100} \text{ m}\right) \times 0.83 = 9.938 \times 10^6 \text{ m}^3$

Total quantity of water lost by evaporation from the reservoir is 9.938Mm<sup>3</sup>.

**48** Water Management

#2. Calculate the daily lake evaporation from the following data from a class – A pan. Assume pan coefficient as 0.80.

Date	10/8/03	11/8/03	12/8/03	13/8/03	14/8/03
Rainfall (mm)	10	0	19	4	10
Water added (mm)	+6	+15	-6	+12	+10

**Solution:** Daily pan evaporation is the sum of the rainfall and the water added or taken out from the pan. Calculation is carried out daily in the following table.

Day	Water Added / Taken Out (mm)	Rainfall (mm)	Pan Evaporation (mm)	Lake Evaporation (mm)
10/8/03	+6	10	16	12.80
11/8/03	+15	0	15	12.00
12/8/03	-6	19	13	10.40
13/8/03	+12	4	16	12.80
14/8/03	+10	10	15	12.00

**2. Empirical Equations:** A large number of empirical equations are available to estimate lake evaporation using commonly available meteorological data. Most formulae are based on the Dalton-type equation and can be expressed in the general form  $E = K \cdot f(u) (e_s - e_a)$ . Where E is lake evaporation in mm/day,  $e_s$  is saturated vapour pressure at the water – surface temperature in mm of mercury,  $e_a$  is actual vapour pressure of overlying air at a specified height in mm of mercury,  $f(u)$  is wind speed correction function and K is coefficient. The term  $e_a$  is measured at the same height at which wind speed is measured. Other commonly used empirical evaporation formulae are as shown in Table 4.5.

**Table 4.5 Lake evaporation calculation by empirical equations**

Name of Equation	Evaporation Rate (mm/day)	Terms Used
Meyer's formula USA, small lake, 1915	$E = \left[ 1 + \frac{U}{16} \right] \cdot C \cdot (e_s - e_a)$	U is monthly mean wind speed in km/h at 9m above ground. C = 0.36 for large deep lakes and 0.50 for shallow lakes.
Rhower's formula USA, 1931	$E = 0.77 (1.465 - 0.000732 P) \times (0.44 + 0.0733 U) (e_s - e_a)$	P is the mean barometric reading in mm Hg and U the mean wind velocity at 0.6m above ground in km/h.
Penman's formula England, Small lake	$E = 8.9 (1 + 0.15U) (e_s - e_a)$	U is measured at 2m above ground level.
USBR formula	$E = 0.833 (4.57 t + 43.3)$	E is mm/month, t mean annual temperature in °C.

Contd...

Name of Equation	Evaporation Rate (mm/day)	Terms Used
Lake Mead formula (mm/day)	$E = 0.046 \times t \times w \times [1 - 0.03(t_a - t_s)](e_s - e_a)$	t is number of days of evaporation, $t_a$ average air temperature in °C+1.9 °C, $t_s$ is the average water surface temperature °C, w is 1.85 U, $e_a$ and $e_s$ in mb.
Lake Hefner	$E = 0.028 U (e_s - e_a)$	$e_a$ and $e_s$ in mb.
Fitzgerald	$E = (10.2 + 3.14 U) (e_s - e_a)$	
Shahtin Mamboub's eqn.	$E = (3.5 + 0.53 U) (e_s - e_a)$	U is measured at 2m above ground.
Kuzmin formula (mm/month)	$E = (152.4 + 19.8 U) (e_s - e_a)$	U is measured at 8m above ground.
Marciano and Harbeck's formula	$E = 0.918 U (e_s - e_a)$	U is measured at 8m above ground.

Wind speed at any height  $h_1$  up to 500 m above ground is calculated using the (1/7)<sup>th</sup> power law given as  $U_{h_1} = U_h \left( \frac{h_1}{h} \right)^{1/7}$ , where  $U_h$  is the wind speed measured at height h. Among all the above equations, Meyer's formula is widely used for the computation of lake evaporation.

#3 A reservoir with average surface spread of 5.0 km<sup>2</sup> in December has the water surface temperature of 30°C and relative humidity of 40%. Wind velocity measured at 2.0m above the ground at a nearby observatory is 15 km/h. Calculate average evaporation loss from the reservoir in mm/day and the total depth and volume of evaporation loss for December.

**Solution:** For water surface temperature of 30°C, the saturation vapour pressure  $e_s = 31.81$  mmHg. (Ref: Table 4.6)

$$\text{Relative humidity } (R_H) = 40\% = 0.40$$

To use Meyer's equation, wind speed is to be converted to a height of 9 m above ground by (1/7)<sup>th</sup> power law,  $U$  (at 9 m above ground level) =  $15 \times (9/2)^{1/7} = 18.6$  km/h.

$$\text{Saturation water pressure of air } e_a = e_s \times R_H = 31.81 \times 0.40 = 12.724 \text{ mmHg.}$$

Using Meyer's equation, evaporation loss is computed as :

$$E = C \left[ 1 + \frac{U}{16} \right] (e_s - e_a) = 0.40 \left( 1 + \frac{18.6}{16} \right) (31.81 - 12.724) = 16.51 \text{ mm/day}$$

$$\text{Depth of evaporation in December} = 31 \times 16.51 = 511.81 \text{ mm.}$$

Volume of evaporated water from the reservoir for December will be

$$(320.5 \times 5.0 \times 10^6) \times 10^{-3} = 2.559 \text{ mm}^3 = 255.9 \text{ ha.m.}$$

Table 4.6 Saturation vapour pressure of water

Temperature (°C)	Saturation Vapour Pressure $e_s$		Slope of Plot between (1) and (2)
	(mmHg)	(millibar)	
(1)	(2)	(3)	(4)
0.0	4.58	6.11	0.30
5.0	6.54	8.72	0.45
7.5	7.78	10.37	0.54
10.0	9.21	12.28	0.60
12.5	10.87	14.49	0.71
15.0	12.79	17.05	0.80
17.5	15.00	20.00	0.95
20.0	17.54	23.38	1.05
22.5	20.44	27.95	1.24
25.0	23.76	31.67	1.40
27.5	27.54	36.71	1.61
30.0	31.81	42.42	1.85
32.5	36.68	48.89	2.07
35.0	42.81	57.07	2.35
37.5	48.36	64.46	2.62
40.0	55.32	73.14	2.95
42.5	62.18	84.23	3.25
45.0	71.2	94.91	3.66

**3. Water Balance Method:** Water balance or water budget method balances all the incoming, outgoing and stored water in a lake or reservoir over a period of time. The equation in its simplest form is  $S_{Inflow} - S_{Outflow} = \text{Change in storage} + \text{Evaporation loss}$ . Or  $E = \Sigma I - \Sigma O \pm \Delta S$ . It can be more generalized by taking all the factors of inflow and outflow. Above equation can be written as:  $E = (P + I_{sf} + I_{gf}) - (O_{sf} + O_{gf} + T) + \Sigma S$ , where  $P$  is the precipitation,  $I_{sf}$  the ground water inflow,  $O_{sf}$  the surface water outflow,  $O_{gf}$  the ground water outflow,  $T$  the transpiration loss,  $\Delta S$  is the change in storage. Measurement of all quantities is possible except  $I_{gf}$ ,  $O_{gf}$  and  $T$ . Therefore, this equation fails to give accurate results since ground water inflow and outflow are very difficult to measure for a lake or reservoir. It may give fairly good result if considered annually but should not be used for daily estimation of evaporation. This equation is good for theoretical considerations or may be applied to watertight lakes located on impervious rocks for budgeting annual water.

**4. Energy Budget or Energy Balance Method:** Like water balance, energy balance or energy budget for lakes or reservoirs can be carried out to calculate lake evaporation. This method uses the conservation of energy by incorporating all the incoming, outgoing and stored energy of a lake in the following form.

$$H_{li} + H_{si} - H_{so} - H_{lo} = H_i + H_{if} + H_s + H_e + H_{lr} + H_{gf}$$

$H_{li}$  = Long wave radiation incident on the surface of water

$H_{si}$  = Solar radiation (heat) or net energy received at water surface by short wave

$H_{so}$  = Reflected solar energy

$H_{lo}$  = Reflected long wave radiation

$H_i$  = Increase in stored heat energy of water

$H_{if}$  = Net energy converted / conducted from and out of the system by flow of water

$H_s$  = Energy conducted from water mass to air as sensible head

$H_e$  = Energy used for evaporation =  $\rho \times E \times L_H$

$H_{lr}$  = Long wave radiation emitted from water

$H_{gf}$  = Heat flux into ground water

$\rho$  = Density of water (cm<sup>3</sup>/g)

$E$  = Evaporation rate (cm/day)

$L_H$  = Latent heat of vaporization (cal/g)

The above energy terms are expressed in calories per unit surface area per day. A water body and energy terms are shown in Fig. 4.6. Daily calculation of lake evaporation by this method is unreliable due to difficulties in measuring all the parameters involved in the equation, but good estimate can be obtained if applied to monthly or yearly values. We can measure or calculate all other terms except the sensible heat transfer between water surface and atmosphere  $H_s$ . It can be measure by:

$$\beta = H_s/H_e$$

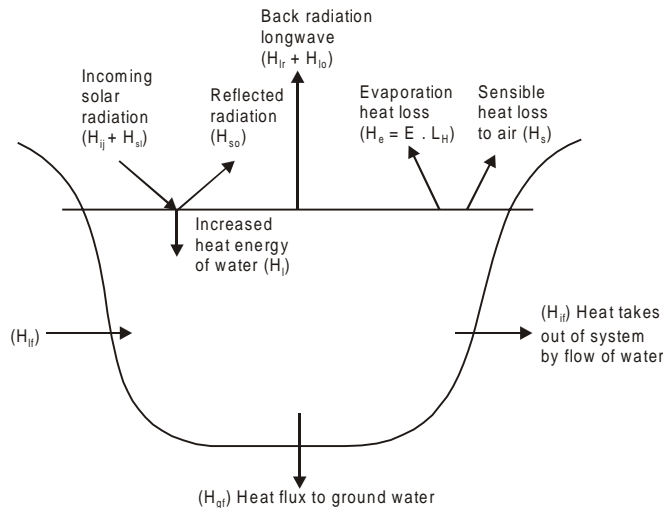

**Fig. 4.6 Energy balance for lakes.**



Above equation is known as Bowen's ratio, defined as the ratio between heats lost by conduction to heat lost by evaporation. Estimate of  $\beta$  can be made from the relation

$$\beta = c.p \frac{(T_s - T_a)}{[100(e_s - e_a)]}$$

Where  $p$  is atmospheric pressure in millibars,  $T_s$  and  $T_a$  are the water surface and air temperature in  $^{\circ}\text{C}$ ,  $c$  is a constant varying between 0.58 and 0.66 (average value being 0.61),  $e_s$  and  $e_a$  are the saturation vapour pressure at water surface and air temperatures in millibar. From above equation, we get  $H_s = \beta \cdot \rho \cdot L_H \cdot E$

$$\text{Therefore, } H_e + H_s = \rho L_H (1 + \beta) E$$

$$\text{or, } E = \frac{(H_e - H_s)}{[\rho L_H (1 + \beta)]}$$

$$\text{Therefore, } E = \frac{(H_{li} + H_{si} - H_{so} - H_{lo} - H_i - H_{if} - H_{lr} - H_{gf})}{[\rho L_H (1 + \beta)]}$$

Values of radiation from sun and sky ( $H_{li} + H_{si}$ ) are available for different latitudes. Reflected solar radiation is dependent on factors like spectral wavelength and turbidity of water and air. For water, it can be taken between 5 to 15 % of incident radiation. Neglecting  $H_{si}$ , net effect of all the long wave radiation  $H_{lr}$  is given in calories per square centimeter per day as the sum of incoming long wave radiation from atmosphere  $H_{li}$  plus reflected long wave radiation  $- H_{lo}$  and long wave radiation emitted by water  $- H_{lr}$  as

$$H_{lr} = H_{li} - (H_{lo} + H_{lr}) = (1 - r) H_{li}$$

The incident solar energy is calculated by the equations proposed by Penman (1948) as

$H_{li} = (0.18 + 0.55n/N) I_o$ , Where  $I_o$  is the solar radiation received at earth's outer surface in ( $\text{cal}/\text{cm}^2\text{-day}$ ),  $n$  is the actual number of bright sunshine hours,  $N$  is the possible maximum number of hours of sunshine at the place.  $I_o$  converted to mm of evaporable water/day. The net outgoing thermal radiation expressed by Penman is given as:

$H_{net} = \sigma T^4 [0.56 - 0.092 e_a^{0.5}] (0.1 + 0.90n/N)$ , in which  $\sigma$  is the *Stefan-Boltzmann* constant =  $2 \times 10^{-9}$  mm of water/day,  $T$  is the water surface temperature in  $^{\circ}\text{Kelvin}$ ,  $H_{if}$  can

be calculated from the relation  $H_{if} = \frac{W_{sh} \cdot H_e \cdot T_e}{L_H}$ , in which  $W_{sh}$  is the specific heat of water in

$\text{cal}/\text{g } ^{\circ}\text{C}$ .  $H_n$  can be calculated from the relation  $H_n = H_{li} (1 - r) - H_{net}$

Net energy added into lake water,  $H_{if}$  is measured by knowing all the volume of water in flowing and coming out of the lake and their corresponding temperatures during the period of water budget. This term should sum all channel inflows and outflows, evaporation, condensation, rainfall, seepage and other losses. The term increase in stored heat energy of water for the lake or reservoir is a difficult parameter to obtain, which can be computed by knowing precisely the

average temperature of lake water and the volume of water at the beginning and end of the budget period. Application of the energy budget principle gives good results for watertight lakes and it may give highly erroneous and confusing results for other lakes.

### 5. Mass Transfer Method

This method is based on theories of turbulent mass transfer in boundary layer to calculate the mass water vapour transfer from the surface to the surrounding atmosphere. Accuracy estimation of the amount of water vapour transferred to atmosphere from a lake surface is still investigated. With the use of quantities measured by sophisticated instrumentation, this method can give satisfactory results. The equation proposed by Thornthwaite and Holzman (1939) takes the following form:

$$E = \frac{0.000119(e_i - e_2)(u_2 - u_1)}{p \times \left[ \ln \left( \frac{h_2}{h_1} \right) \right]}$$

where E is m/sec,  $u_2$  and  $u_1$  are the velocities of wind in m/

sec at heights  $h_2$  and  $h_1$  m respectively,  $e_2$  and  $e_1$  are vapour pressure of air in pascal (Pa) at height(s)  $h_2$  and  $h_1$ , p is mean atmospheric pressure in Pa (1 N.m<sup>2</sup> = 1 Pa; 1 kPa = 10 mb) between lower height  $h_1$  and upper height  $h_2$ . Height  $h_1$  is taken close to water surface level.

### 4.3 TRANSPIRATION

Plants absorb water from the soil through minute root hairs at the tips of their rootlets. Mineral salts are also absorbed in very dilute solution, using water as the vehicle. The solutions are transported through roots and stems to the leaves where plant food is produced from the sap and carbon dioxide absorbed from the atmosphere, using the energy from the sun operating chlorophyll. These plant foods, again using water as the vehicle, are distributed through the plant for cell growth and tissue building. Most of the water absorbed through the roots is discharged from the plant as vapour in the process known as transpiration. As much as 99 % of the total water received by a plant through its roots is lost to the atmosphere by this process.

**Evapotranspiration:** while transpiration takes place, the land areas in which plants stand also lose moisture by the evaporation of water from soil and water bodies. In hydrology and irrigation practice, it is found that evaporation and transpiration processes can be considered advantageously under one head as Evapotranspiration. Evapotranspiration also uses the term consumptive use to denote this loss. For a given set of atmospheric conditions, Evapotranspiration obviously depends on the availability of water. If sufficient moisture is always available to completely meet the needs of vegetation fully covered the area, the resulting evapotranspiration (PET). Potential evapotranspiration no longer critically depends on soil and plant factors but depends essentially on climatic factors. The real evapotranspiration occurring in a specific situation is called actual evapotranspiration (AET). If the water supply to the plant is adequate, soil moisture will be at the field capacity and AET will be equal to PET. If the water supply is less than PET, soil dries out and the ration AET/PET would be less than 1.0. A relation between AET/PET and available moisture can be developed for different

types of soils on the basis of experimental results. For the same AET/PET ratio, sandy soil has more available moisture than clayey soil. In other words, for the same percentage of available moisture, ratio of AET/PET will be less for sandy soil than clayey soil (Fig. 4.7).

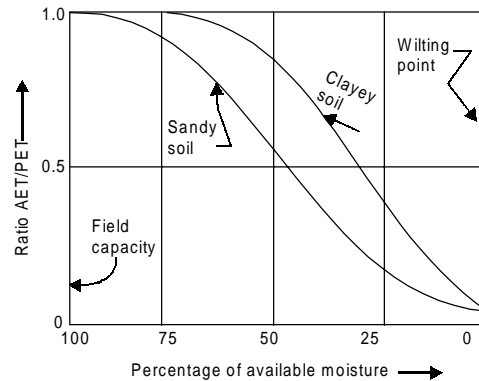

Fig. 4.7 Comparison of AET/PET ratio for sandy and clayey soils.

### Factors Affecting Transpiration

**1. Solar radiation:** Transpiration and plant growth are related to radiation received. Thus while 75 to 90% of daily soil evaporation occurs between sunrise and sunset, about 95% of the daily transpiration occurs during the daylight hours. Optimum temperature and radiation for maximum growth vary with the plant species but all activity virtually ceases when the temperature drops to near 4.5°C.

**2. Moisture:** Some investigators believe that transpiration is independent of available moisture until it has recorded to the wilting point (moisture content at which permanent wilting of plants occurs) while others assume that transpiration is roughly proportional to the moisture remaining in the soil and available to plants.

**3. Rate of plant growth:** The transpiration is closely related to the rate of plant growth is well established. Thus there is a pronounced seasonal and annual variation in addition to the diurnal cycle. Transpiration is restricted to the growing season and stage of development is an important factor.

### Measurement of Transpiration/Evapotranspiration

#### Transpiration

Most measurements are made with a “Phytometer” a large vessel filled with soil in which one or more plants are rooted. The only escape of moisture is by transpiration (the soil surface is sealed to prevent evaporation) that can be determined by weighing the plant and the container at desired intervals of time. By providing aeration and additional water a phytometer study may be carried through the entire cycle of a plant. It is virtually impossible to simulate natural conditions and therefore the results of phytometer observations are mostly of academic interest

to the hydrologist. Transpiration ratio (TR) is the ratio between the amount of water consumed and the dry matter produced (exclusive of the roots, sometimes only the grains).

$$TR = \frac{\text{weight of water consumed}}{\text{weight of dry matter produced}} \text{ e.g. TR (wheat) = 450, TR (rice) = 700.}$$

The transpiration varies approximately exponentially with the temperature (Meyer). According to him transpiration starts at 5°C and the average annual losses in the North Central United State of America are:

- (i) Grains: 22.5 to 25 cm
- (ii) Grass: 22.5 to 25 cm
- (iii) Crops: 22.5 to 25 cm
- (iv) Deciduous trees: 20 to 30 cm
- (v) Small trees and bush: 15 to 20 cm
- (vi) Conifers: 10 to 15 cm.

**Evapotranspiration:** There are numerous approaches to estimation of evapotranspiration, none of which is generally applicable for all purposes. In some hydrologic studies, mean basin Evapotranspiration is required while in other cases water used of a particular crop cover or change in water use resulting from changed vegetal cover is required. Evapotranspiration can be estimated by various methods such as: (1) Experimental methods, and (2) Climatic approach.

**1. Experimental Methods:** The measurement of evapotranspiration for given vegetation type can be carried out in two ways: either by using field plots or by using Lysimeters.

*Field Plots:* Application of a water budget to field plots produces satisfactory results only under ideal conditions that are rarely exist. Precise measurement of percolation is not possible and consequent errors tend to be accumulative. In special plots, all the elements of the water budget in a known interval of time are measured and the evapotranspiration determined as:

$$\text{Evapotranspiration} = [\text{precipitation} + \text{irrigation input} - \text{runoff} - \text{increase in soil storage} - \text{groundwater loss}].$$

Measurements are usually confined to precipitation, irrigation input, surface runoff and soil moisture. Groundwater loss due to deep percolation is difficult to measure and can be minimized by keeping the moisture condition of the plot at the field capacity.

**Lysimeters:** A lysimeter is a special tank containing soil, which is set in the same surrounding as that in the field. A lysimeter is buried to the level of natural soil and its diameter varies from 0.60m to 3.3m and depth varies from 1.8m to 3.3m. Details of a lysimeter are shown in Fig 4.8. Arrangements are made to weigh the lysimeter whenever reading is required to be taken. A metering device measures outflow from the lysimeter. If P is precipitation to the system, W the water supplied, and O the quantity of water drained out of the system, then Evapotranspiration is calculated as  $P + W = O + E_t + \Delta S$ , where  $E_t$  is the evapotranspiration and  $\Delta S$  the change in soil moisture storage. P, W and O are measured directly. When arrangement for weighing a lysimeter is made, then  $\Delta S$  can be found out by the difference of the weight of the lysimeter

before and after the experiments over the periods of days. Knowing all other quantities of equation,  $E_t$  can be computed. To produce results very close to field, soil conditions, moisture content, plant types and the methods of water application should be properly chosen such that they represent the surrounding natural condition. The vegetation around the lysimeter should be the same as that inside in order to avoid disturbing border effects. To the same end, the depth of lysimeter should not be less than 1.5m and area not less than 1.0 sq. m. Lysimeter are expensive to maintain and time consuming.

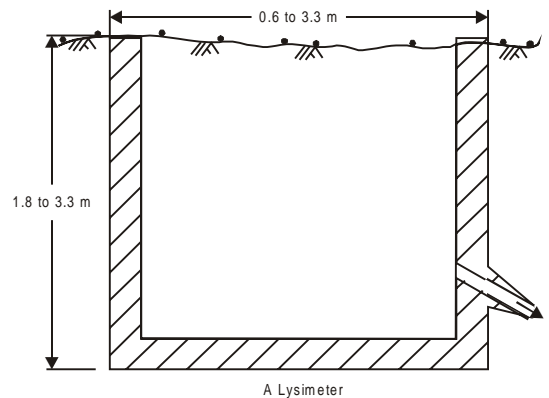

Fig. 4.8 A Lysimeter.

**2. Climatic Approach:** Several empirical techniques have been developed for estimating potential evapotranspiration from readily available climatic data. Some empirical and theoretical equations are derived on the basis of regional relationship between measured  $E_t$  and climatic factors. The following methods are the combination of some empirical, analytical and theoretical approaches.

*Blaney – Criddle Method:* Blaney and Criddle (1962) proposed an empirical relation, which is used largely by irrigation engineers to calculate crop water requirement of various crops. Estimation of potential evapotranspiration (consumptive use) is carried out by correlating it with sunshine temperature. Sunshine at a place is dependent on latitude of the place and varies with month of the year. Table below gives the values of percentages of monthly daytime for use in Blaney – Criddle equation. PET for a crop during its growing season is given by  $Pet = \Sigma K.F$ ; where  $F = (0.0457T_m + 0.8128) P$ .

Here  $K$  is the monthly crop coefficient to be determined from experimental data,  $F$  the monthly consumptive use factor,  $PET$  the potential evapotranspiration in cm,  $T_m$  the mean monthly temperature in °C,  $P$  is the monthly percentage of hours of bright sunshine in the year.

**Table 4.7 Monthly daytime percentage hours (P) to be used by blaney – Criddle formula**

North Latitude (Deg.)	Jan	Feb	Mar	Apr	May	Jun	Jul	Aug	Sep	Oct	Nov	Dec
0	8.5	7.66	8.49	8.21	8.50	8.22	8.50	8.49	8.21	8.50	8.22	8.50
5	8.32	7.56	8.47	8.29	8.66	8.40	8.68	8.60	8.23	8.42	8.06	8.30
10	8.13	7.47	8.45	8.37	8.81	8.60	8.86	8.71	8.25	8.34	7.91	8.10
15	7.94	7.36	8.43	8.44	8.89	8.80	9.05	8.83	8.28	8.26	7.75	7.88
20	7.74	7.25	8.41	8.52	9.15	9.00	9.23	8.96	8.30	8.18	7.58	7.66
25	7.53	7.14	8.39	8.61	9.33	8.23	9.45	9.09	8.32	8.09	7.40	7.42
30	7.30	7.03	8.38	8.72	9.53	9.49	9.67	9.22	8.33	7.99	7.19	7.15
35	7.05	6.88	8.35	8.83	9.76	9.77	9.93	9.37	8.36	7.87	6.97	6.86
40	6.76	6.72	8.33	8.95	10.02	10.08	10.22	9.54	8.39	7.75	6.72	6.52
45	6.42	6.54	8.30	9.09	10.33	10.47	10.57	9.75	8.41	7.60	6.42	6.13
50	5.98	6.30	8.24	9.24	10.68	10.91	10.99	10.00	8.46	7.45	6.10	5.65
55	5.42	6.01	8.16	9.41	11.13	11.53	11.56	10.34	8.52	7.25	5.65	5.03
60	4.67	5.65	8.08	9.65	11.74	12.34	12.31	10.70	8.57	6.68	4.31	4.22

**Table 4.8 Mean monthly values of possible sunshine hours (N)**

North Latitude in Degrees						
Month	0°	10°	20°	30°	40°	50°
Jan	12.1	11.6	11.1	10.4	9.6	8.6
Feb	12.1	11.8	11.5	11.1	10.7	10.1
Mar	12.1	12.1	12.0	12.0	11.9	11.8
Apr	12.1	12.4	12.6	12.9	13.2	13.8
May	12.1	12.6	13.1	13.7	14.4	15.4
Jun	12.1	12.7	13.3	14.1	15.0	16.4
Jul	12.1	12.6	13.2	13.9	14.7	16.0
Aug	12.1	12.4	12.8	13.2	13.8	14.5
Sept	12.1	12.9	12.3	12.4	12.5	12.7
Oct	12.1	11.9	11.7	11.5	11.2	10.8
Nov	12.1	11.7	11.2	10.6	10.0	9.4
Dec	12.1	11.5	10.9	10.2	9.1	8.1

Table 4.9 Monthly crop coefficient factor K to be used for blaney – criddle method

Crop →	Rice	Wheat	Maize	Sugarcane	Cotton	Potato	Corn	Vegetable	
								Light	Dense
Value of K	1.1	0.65	0.65	0.90	0.65	0.70	0.75	0.80	1.20
Range of K	0.85- 1.3	0.5-0.75	0.5-0.75	0.8-1.0	0.5-0.9	0.65-.075	0.65-0.85	0.7-1.0	1.1-1.4

#4 Use Blaney–Criddle method to calculate consumptive use (PET) for rice crop grown from July to September in Maharashtra at a latitude 20 N from the following data taken from a nearby observatory. Find the net irrigation demand for rice using the given rainfall during crop period.

Month →	Jul	Aug	Sep
Mean Temp. °C	13	16	25
Rainfall, (mm)	15	20	10

Sol: For rice crop, monthly crop coefficient K of equation may be taken as 1.10. Mean monthly sunshine hours for latitude of 20N for the months of July, August and September are obtained from Table and tabulated below.

*Blaney–Criddle Method of Computation of Consumptive Use of Rice Crop for Example*

Month	Mean Monthly Temp. (T <sub>m</sub> )	Monthly % (P) of Day Time Hours from Table	Monthly Consumptive Use Factor (F)	K	PET (4) × (5)	Effective Rainfall at 80% (cm)	Depth of Irrigation Demand (6)-(7) (cm)
1	2	3	4	5	6	7	8
Jul	13	7.74	10.89	1.1	11.98	1.20	10.78
Aug	16	7.25	11.19	1.1	12.31	1.60	10.71
Sep	25	8.41	16.44	1.1	18.00	0.80	17.28

$$\begin{aligned}
 \text{F for col. (4) for July} &= (0.0457 T_m + 0.8128) \times P \\
 &= (0.0457 \times 13 + 0.8128) \times 7.74 = 10.89 \text{ cm} \\
 \text{F (August)} &= (0.0457 \times 16 + 0.8128) \times 7.25 = 11.19 \text{ cm} \\
 \text{F (September)} &= (0.0457 \times 24 + 0.8128) \times 8.41 = 16.44 \text{ cm} \\
 \text{The net irrigation demand} &= 10.78 + 10.71 + 17.28 = 38.77 \text{ cm.}
 \end{aligned}$$

*Penman Method:* Penman developed a theoretical formula based on the principles of both energy-budget and mass-transfer approaches to calculate potential evapotranspiration. A simple

energy budget neglecting all minor losses can be written as  $E_t = \left[ \frac{H_a + \alpha E_a}{A + \alpha} \right]$ , where H is the heat budget of an area with crops which is the net radiation in mm of evaporable water per day,  $E_t$  the daily evaporation from free water surface in mm/day,  $\alpha$  is a constant (called psychrometric constant whose value is 0.49 mmHg/°C or 0.66 mb/°C), A the slope of the saturated vapour

pressure vs. temperature curve at mean air temperature,  $E_a$  is the drying power of air which includes wind velocity and saturation deficit and is estimated from the relation:

$E_a = 0.002187 (160 + u_2) (e_s - e_a)$ ; where  $u_2$  is the mean wind speed in km/day measured 2m above the ground,  $e_s$  is saturation vapour pressure at mean air temperature in mm Hg,  $e_a$  is actual vapour pressure in the air in mm of mercury and  $H$  is the daily net radiation in mm of evaporable water and is estimated from the energy budget theories using the relation:

$H = H_a (1 - r) (0.29 \cos\phi + 0.55n/N) - \sigma T_a^4 (0.56 - 0.092 \sqrt{e_a}) (0.10 + 0.9 n/N)$ ; where  $H_a$  is the extraterrestrial solar radiation received on a horizontal surface in mm of evaporable water per day,  $\phi$  the latitude of the place where PET is to be computed,  $r$  is the reflection coefficient whose values for close crops may be taken as 0.15 – 0.25, for barren land 0.05 – 0.45 and for water surface 0.05,  $n$  is the actual duration of bright sunshine which is a function of latitude and is an observed data at a place,  $N$  is the maximum possible hours of bright sunshine available at different location,  $\sigma$  is the Stefan-Boltzman constant =  $2.01 \times 10^{-9}$  mm/day,  $T_a$  is the mean air temperature in  $^{\circ}\text{K} = (273 + ^{\circ}\text{C})$  and  $e_a$  is the actual vapour pressure in mm of Hg. The wind speed measured at any other height  $z$  can be reduced

to 2m height by the relation:  $u_2 = u \left( \frac{2}{z} \right)^{0.143}$

Knowing all other data from the table and measuring  $n$ ,  $e_a$ ,  $u_2$  at the place, PET can easily be calculated from the relation given by Penman. This method is finding its increasing application for crop water estimation by various countries.

*Hargreaves Method:* Hargreaves proposed monthly consumptive use coefficient  $k$  for various crop groups which when multiplied with monthly pan evaporation values gives PET.

$\text{PET} (E_c) = \Sigma k.E_p$ ; Where  $k$  is monthly consumptive use coefficient, which is dependent on the crop grown,  $E_p$  the pan evaporation in mm and PET in mm. consumptive use coefficient  $k$  is different for different crops and is different for the same crop at different places. For the same crop, it is different during stages of its growth. Various research stations report values of  $k$  for different crops. In absence of figure for specific crop, data from Table 4.10 below may be used with caution.

**Table 4.10 Values of Hargreaves monthly consumptive use coefficient  $k$**

Crop Group	Important Crops Under the Group	$E_c/E_p$
Group A	Potato, cotton, maize, bean, peas, jowar, beat	0.20 – 1.00
Group B	Tomato, olive, plumes and some delicious fruits	0.15 – 0.75
Group C	Onions, grapes, melons, carrots, hops	0.12 – 0.60
Group D	Wheat, barley, celery and other grass type plants	0.10 – 0.90
Group E	Pesters, plantin, orchard crops etc	0.70 – 1.10
Group F	Orange, fruits, citrus crop	0.60
Group G	Sugarcane, alfalfa etc	0.50 – 1.00
Paddy	Maximum at 50% of growth is	0.80 – 1.30



$E_t$  ( $C_o$ ) is the evapotranspiration and  $E_p$  is the pan evaporation.  $E_t/E_p = k$  is the consumptive use coefficient. For dark vegetation plants,  $k$  should be taken higher for the same group and for lighter crop, it is lesser. Tall plants have higher value of  $k$  than small plants of same degree of greenness and density.

**Table 4.11 Hargreaves average value of consumptive use coefficient ( $k = E_t/E_p$ )**

% of Crop Growing Season	Values of $k$ (Average)											
	Group											
	A	B	C	D	E	F	G	Rice	Wheat		Cotton	Maize
									L	P	P	L
1	2	3	4	5	6	7	8	9	10	11	12	13
0	0.20	0.15	0.12	0.08	0.90	0.60	0.50	0.80	0.14	0.30	0.22	0.40
5	0.20	0.15	0.12	0.08	0.90	0.60	0.55	0.90	0.17	0.40	0.22	0.42
10	0.36	0.27	0.22	0.15	0.90	0.60	0.60	0.95	0.23	0.51	0.23	0.47
15	0.50	0.38	0.30	0.19	0.90	0.60	0.65	1.00	0.33	0.62	0.24	0.54
20	0.64	0.48	0.38	0.27	0.90	0.60	0.70	1.05	0.45	0.73	0.26	0.63
25	0.75	0.56	0.45	0.33	0.90	0.60	0.75	1.10	0.60	0.84	0.35	0.75
30	0.84	0.63	0.50	0.40	0.90	0.60	0.80	1.14	0.72	0.92	0.58	0.85
35	0.92	0.69	0.55	0.46	0.90	0.60	0.85	1.17	0.81	0.96	0.80	0.96
40	0.97	0.73	0.58	0.52	0.90	0.60	0.90	1.21	0.88	1.10	0.95	1.04
45	0.99	0.74	0.60	0.58	0.90	0.60	0.95	1.25	0.90	1.10	1.03	1.07
50	1.00	0.75	0.60	0.65	0.90	0.60	1.00	1.30	0.91	1.00	1.08	1.09
55	1.00	0.75	0.60	0.71	0.90	0.60	1.00	1.30	0.90	0.91	1.08	1.10
60	0.99	0.74	0.60	0.77	0.90	0.60	1.00	1.30	0.89	0.80	1.07	1.11
65	0.96	0.72	0.58	0.82	0.90	0.60	0.95	1.25	0.86	0.65	1.05	1.10
70	0.91	0.68	0.55	0.88	0.90	0.60	0.90	1.20	0.83	0.51	1.00	1.07
75	0.85	0.64	0.51	0.90	0.90	0.60	0.85	1.15	0.80	0.40	0.93	1.04
80	0.75	0.56	0.45	0.90	0.90	0.60	0.80	1.10	0.76	0.30	0.85	1.00
85	0.60	0.45	0.36	0.80	0.90	0.60	0.75	1.00	0.71	0.20	0.73	0.97
90	0.46	0.35	0.28	0.70	0.90	0.60	0.70	0.90	0.65	0.12	0.62	0.89
95	0.28	0.21	0.17	0.60	0.90	0.60	0.55	0.80	0.58	0.10	0.50	0.81
100	0.20	0.20	0.17	0.60	0.90	0.60	0.50	0.20	0.51	0.10	0.40	0.70
Seasonal Value	—	—	—	—	—	—	—	—	0.61	0.61	0.68	0.86

P = Poona, L = Ludhiana. Local values of  $k$  should be used whenever available.

#5 Use Hargreaves method to calculate crop water requirements for paddy to be grown from January 10 to March 30. Class A pan evaporation values for the months are 11, 12 and 14 cm respectively. Rainfall during the three months can be taken as 10, 15 and 30mm. Calculate the gross irrigation requirement at the head of field if irrigation efficiency is 85 %.

**Solution:** Referring above Table 4.10 for rice, value of  $k$  for the percent of growing season are found and entered in column 5 of Table below.  $E_t$  values are computed in column 6. Crop period for paddy is taken as 80 days from January 10 to March 30.

Date	No. of Days Up to Mid Point	% Growing Season	Pan Evaporation $E_p$ (cm)	$K$	$E_t = k \cdot E_p$	Rainfall During the month (cm)	Net irri. Requirement = col. 6 – 80% x col 7. (cm)	Gross irri. Requirement = col. 8 / Efficiency
1	2	3	4	5	6	7	8	9
10 – 31 Jan	11	100(11/80) = 13.75	11	0.98	10.78	1.0	9.98	11.74
1 – 28 Feb	38	100(38/80) = 47.50	12	1.28	15.36	1.5	14.16	16.66
1 – 30 Mar	71	100(71/80) = 88.70	14	1.20	16.80	3.0	14.40	16.94
Total 80 days					42.94		38.54	45.34

Consumptive use for paddy = 42.94 cm.

Net irrigation requirement = consumptive use – effective rainfall = 38.54 cm

Gross irrigation demand = net irrigation demand / efficiency = 45.34 cm.

#### 4.4 INTERCEPTION

The losses occur on account of evaporation of water caught and held in suspension by vegetation. When it rains over a catchment not all the precipitation falls directly onto the ground. Before it reaches the ground, a part of it may be caught by the vegetation and subsequently evaporated. The volume of water so caught is called interception. The adhesive force between the water drops and the vegetation holds back the drops of water against gravity until they grow in size to over weigh and slip down. The intercepted precipitation may follow one of the three possible ways:

1. It may retain by the vegetation as surface storage and returned to the atmosphere by evaporation; a process called interception loss.
2. It can drip off the plant leaves to join the ground surface or the surface flow, called through fall, and
3. The rainwater may run along the leaves and branches and down the stem to reach the ground surface, called stem flow.

Interception loss is solely due to evaporation and does not include transpiration, through fall or stem flow. Factors on which interception depends are: (a) intensity and duration of storm, (b) density of trees, (c) types of trees and other obstructions, (d) season of the year and (e) wind velocity at the time of precipitation.

The amount of water intercepted in a given area is extremely difficult to measure. It depends on the species composition of vegetation, its density and also on the storm characteristics. It is estimated that of the total rainfall in an area during a plant growing season the interception loss is about 10 % to 20 %. Interception is satisfied during the first part of a storm and if an area experiences a large number of small storms, the annual interception loss due to forests in such cases will be high, amounting to greater than 25 % of the annual precipitation. Quantitatively, the variation of interception loss with the rainfall magnitude per storm for small storms is as shown in Fig 4.9. It is seen that the interception loss is large for a small rainfall and levels off to a constant value for larger storms. For a given storm, the interception loss is estimated as:  $I_i = S_i + K_i \cdot E \cdot t$ . E. t. where  $I_i$  = interception loss in mm,  $S_i$  = interception storage whose value varies from 0.25 to 1.25 mm depending on the nature of vegetation,  $K_i$  = ratio of vegetal surface area to its projected area,  $E$  = evaporation rate in mm/h during the precipitation and  $t$  = duration of rainfall in hours.

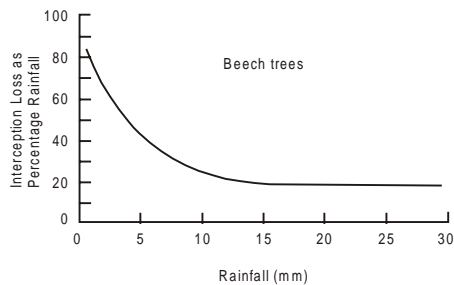

Fig. 4.9 Interception losses.

It is found that coniferous trees have more interception loss than deciduous ones. Also, dense grasses have nearly same interception losses as full-grown trees and can account for nearly 20 % of the total rainfall in the season. Agricultural crops in their growing season also contribute high interception losses. In view of these, the interception process has a very significant impact on the ecology of the area related to silvicultural aspects and in the water balance of a region. However, in hydrological studies dealing with floods interception loss is rarely significant and is not separately considered. The common practice is to allow a lump sum value as the initial loss to be deducted from the initial period of the storm.

Horton (1919) proposed a straight-line relation between precipitation  $P$  in mm and total interception loss  $I_i$  for ash tree in the following form:  $I_i = 0.38 + 2.3P$

Depending on the vegetal cover and precipitation, a general form of equation for interception loss can be written as:  $I_i = a.P + b (1 - e^{-P/b})$ ; where  $a$  and  $b$  are constants which depend on the factors of infiltration loss,  $a$  varies between 0.01 and 0.2 and  $b$  between 2.5 and 38 % of rainfall,  $P$  is the precipitation depth in mm. When the intensity of rainfall is 25-mm/h interception rates vary between 15 % for soybean crop and 57 % for tall grass.

#### 4.5 DEPRESSION STORAGE

When the precipitation of a storm reaches the ground, it must first fill up all depressions before it can flow over the surface. The volume of water trapped in these depressions is called depression storage. This amount is eventually lost to runoff through processes of infiltration and evaporation and thus forms a part of the initial loss. Depression storage depends on a vast number of factors such as: (a) the type of soil, (b) the condition of the surface reflecting the amount and nature of depression, (c) the slope of the catchment and (d) the antecedent precipitation, as a measure of the soil moisture. Qualitatively, it has been found that antecedent precipitation has a very pronounced effect on decreasing the loss to runoff in a storm due to depression. Values of 0.50cm in sand, 0.4cm in loam and 0.25cm in clay can be taken as representatives for depression storage loss during intensive storm.

A general form of depression storage curve can be given as:  $V_{SD} = K (1 - e^{-P_e/k})$ ; where K is the capacity of the basin to store water in its depressions,  $V_{SD}$  the depression storage volume,  $P_e$  the volume of precipitation in excess of infiltration and interception. It is an exponentially decaying curve and attains the value of K when the ratio  $P_e/K$  increases. Depression storage helps to reduce soil erosion and increase soil moisture content. Therefore, farmers are encouraged to go for terrace farming to conserve soil and rain water for beneficial uses. But this water is a definite loss of water resource project. The sum of infiltration and depression storage can vary from 10 to 50 mm per storm depending on their intensity, duration and other characteristics.

#### 4.6 INFILTRATION

It is well known that when water is applied to the surface of a soil, a part of it seeps into the soil. This movement of water through the soil surface is known as infiltration and plays a very significant role in the runoff process by affecting the timing distribution and magnitude of the surface runoff. Creation of hydrogen bond between soil particles and the water initiate the infiltration process. The adhesive force of attraction between soil and water, the surface tension, capillary and gravitational forces help to force more water between the pores of soil particles as more water is added to the system due to rain. Further, infiltration is the primary steps in the natural groundwater recharge.

Infiltration is the flow of water into the ground through the soil surface and the process can be easily understood through a simple analogy. Consider a small container covered with wire gauze as in Fig. 4.10. If water is poured over the gauze, a part of it will go into the container and a part overflows. Further, the container can hold only a fixed quantity and when it is full no more flow into the container can take place. This analogy, though a highly simplified one, underscores two important aspects, viz., (i) the maximum rate at which the ground can absorb water, the infiltration capacity and (ii) the volume of water that it can hold, the field capacity. Since the infiltrate water may contribute to groundwater discharge in addition to increasing the soil moisture, the process can be schematically modeled as in Fig. 4.11. This figure considers two situations, viz, low-intensity rainfall and high-intensity rainfall, and is self-explanatory.

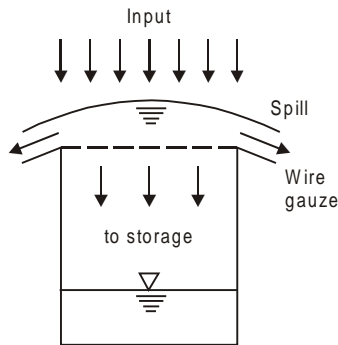

Fig. 4.10 Concept of infiltration.

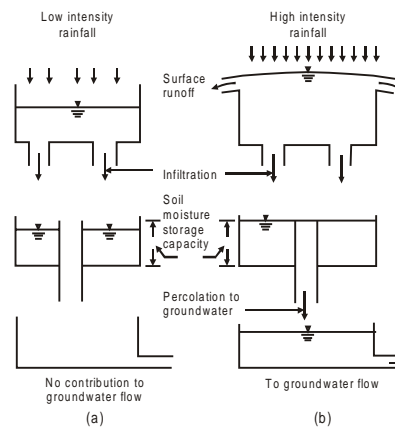

Fig. 4.11 Concept of groundwater discharge.

Infiltration capacity is the maximum rate at which a given soil can absorb water under a given set of conditions at a given time. At any instant the actual infiltration  $f_t$  can be equal to infiltration capacity  $f_0$  only when the rainfall intensity is greater than  $f_0$ , otherwise actual infiltration will be equal to the rate of rainfall. This can be observed during low intensity rainfall when there is no surface runoff produced due to precipitation. Once water enters into the soil, the process of transmission of water within the soil known as percolation takes place, thus removing the water from near the surface to down below, charging the groundwater reservoir. Infiltration and percolation are directly interrelated. When percolation stops, infiltration also stops. During any storm, infiltration is the maximum at the beginning of the storm, decays exponentially and attains a constant value of  $f_c$  as the storm progresses.

### Factors Affecting Infiltration

Factors affecting infiltration depend on both meteorological and soil medium characteristics.

**Surface entry:** If a soil surface is bare, the impact of raindrops causes in washing of finer particles and clogs the surface. This retards infiltration. An area covered by grass and other bushy plants has better infiltration capacity than a barren land.

**Percolation:** For infiltration to continue, the force of gravity and capillary actions must transmit water that has entered the soil down. When percolation rate is slow, the infiltration rate is bounded by the rate of percolation. This depends on the factors like type of soil, its composition, permeability, porosity, stratification, presence of organic matter and presence of salts.

**Antecedent moisture condition:** Infiltration depends on the presence of moisture in the soil. For the second storm in succession, the soil will have lesser rate of infiltration than the first maiden storm of the season. Except sandy soil most other soils have swelling ingredients, which swells in presence of water and reduce infiltration rate to the extent of their presence.

**Climatic conditions:** Temperature affects the viscosity of water. Flow of water within the body of the soil is laminar, the flow being directly related to viscosity. In summer therefore, less viscous water causes more infiltration than in winter. Other climatic factors may not influence

infiltration rate to the extent, temperature does, and therefore, temperature can be considered as the only vibrant climatic factor affecting infiltration.

**Rainfall intensity and duration:** During heavy rainfall, the topsoil is affected by mechanical compaction and by the inwash of finer material. This leads to faster decrease in the rate of infiltration than with low intensities of rainfall. Duration of rainfall affects to the extent that when the same quantity of rain falls in  $n$  number of isolated of a continuous one, the infiltration will be higher in the former case.

**Human activities:** When crops are grown or grass covers a barren land, the rate of infiltration is increased. On the other hand construction of roads, houses etc reduce infiltration capacity of an area considerably.

**Depletion of groundwater table:** Position of groundwater should not be very close to the surface for infiltration to continue. The quantity of infiltrated water entering into the soil should be drained out fully from the topsoil zone so that there is some space available for the infiltrated water to store during next rain.

**Quality of water:** Water containing silt, salts and other impurities affect the infiltration to the extent they are present. Salts present affect the viscosity of water and may also react chemically with soil to form complexes, which obstruct the porosity of soil, thereby affecting infiltration. Silts clog the pore spaces retarding infiltration rate considerably.

**Vegetation:** Soil covered with vegetation has greater than barren land. Because of growth and decay of roots and bacterial activities, dense natural forest provides good infiltration than sparsely planted crops.

**Grain size of soil particle:** Other factors remaining the same, infiltration rate is directly proportional to the grain size diameter. When swelling minerals like illite and montmorillonite are present in soils, the infiltration rate reduces.

**Catchment parameters:** A correlation between the drainage density and infiltration can be established for various basins. Such curves exhibit negative correlation. When the drainage density increases, infiltration capacity decreases.

### ***Field Measurement Using Infiltrimeters***

**Single tube infiltrimeter:** This is a simple instrument consisting essentially of a metal cylinder, 30 cm diameter and 60 cm long, open at both ends. This cylinder is driven into the ground to a depth of 50 cm (Fig. 4.12). Water is poured into the top part to a depth of 5 cm and pointer is set to mark the water level. As infiltration proceeds, the volume is made up by adding water from burette to keep the water level at the tip of the pointer. Knowing the volume of water added at different time intervals, the plot of the infiltration capacity versus time is obtained. The experiments are continued till a uniform rate of infiltration is obtained and this may take two to three hours. The surface of the soil is usually protected by a perforated disc to prevent formation of turbidity and it's setting on the soil surface. Sufficient precautions should be taken to drive the cylinder into the ground with minimum disturbance to the soil structure. The major criticism is that water spreads out immediately beyond the bottom of the cylinder that does not represent a true condition in the field.

**Double tube infiltrometer:** To overcome the objections of a single ring infiltrometer a set of two concentric hollow cylinders of same length are used (Fig. 4.13). Water is added to both the rings to maintain the same height. Reading of the burette for the inner cylinder is taken as infiltration capacity of the soil. The outer cylinder is maintained to prevent spreading of water from the inner one. The important disadvantages still prevalent in these types of infiltrometers are: (i) the raindrop — impact effect is not simulated, (ii) the driving of the tube or rings disturbs the soil structure, and (iii) the results of the infiltrometer depend on some extent on their size. Larger diameter infiltrometers give more accurate and always lesser value of infiltration than smaller diameter type.

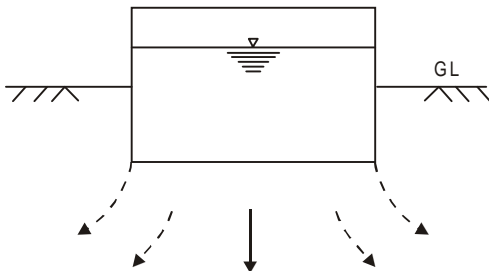

Fig. 4.12 Single tube infiltrometer.

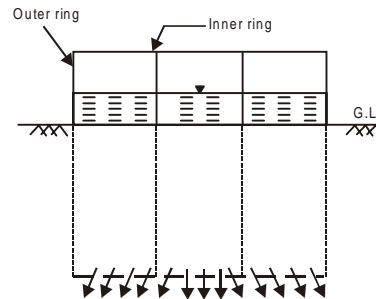

Fig. 4.13 Double tube infiltrometer.

#6 Observations on double cylinder infiltrometer on an experimented farm were recorded as under. (i) Draw infiltration depth versus time curve, (ii) Rate of infiltration (I) versus Time curve and (iii) Obtain equation of both of them.

Time Hr-min	Point Gauge Reading with Reference to Beginning (m)	Remark
10-31	14.5	
10-32	14	
10-35	12.8	
10-40	11.3	
10-45	10.27 / 15	Refilling
11-00	12.40	
11-15	10.30 / 14	Refilling
11-30	12.60	
11-45	11.50 / 14	Refilling
12-00	12.95	
12-15	11.95	
12-45	10.15 / 14.7	Refilling
13-15	13	
13-45	11.30	

**Solution:**

Time Hr – min (min)	Time Difference (min)	Cumulative Time (min)	Infiltration Depth (cm)			Rate of Infiltration $I=(5)/(2) \times 60$	Remark
			Point Gauge Reading	Difference	Cumulative Depth		
1	2	3	4	5	6	7	8
10-31	-	-	14.5	-	-	-	
10-32	1	1	14	0.5	0.5	30	
10-35	3	4	12.8	1.2	1.7	24	
10-40	5	9	11.3	1.5	3.2	18	
10-45	5	14	10.27/15	1.03	4.23	12.36	Refilling
11-00	15	29	12.4	2.6	6.83	10.4	
11-15	15	44	10.3/14	2.1	8.93	8.4	Refilling
11-30	15	59	12.6	1.4	10.33	5.6	
11-45	15	74	11.5/14	1.1	11.43	4.4	Refilling
12-00	15	89	12.95	1.05	12.48	4.2	
12-15	15	104	11.95	1	13.48	4	
12-45	30	134	10.15/14.7	1.8	15.28	3.6	Refilling
13-15	30	164	13	1.7	16.98	3.4	
13-45	30	194	11.30	1.7	18.68	3.4	

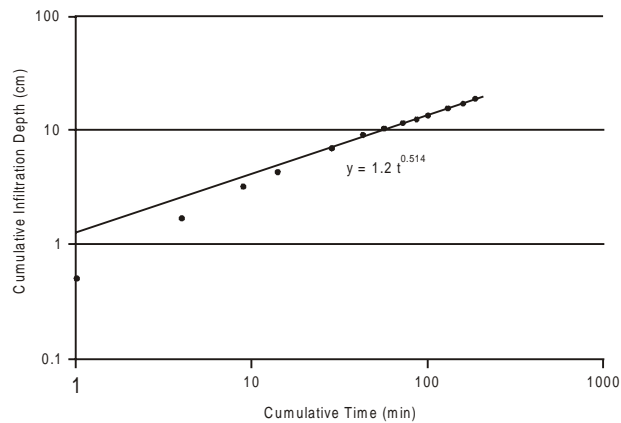

**Figure # 6 (i)**



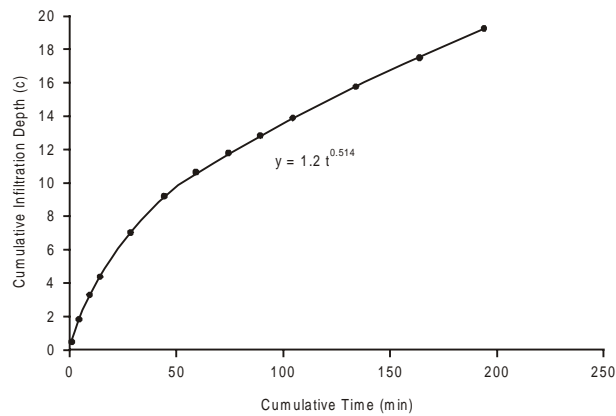

Figure # 6 (ii)

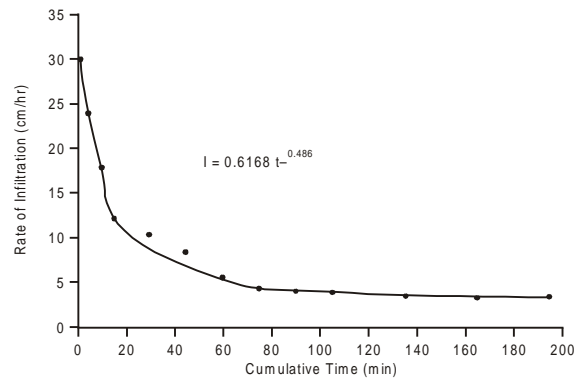

Figure # 6 (iii)

$$\text{From Graph: } \beta = (\log y_1 - \log y_2) / (\log x_1 - \log x_2)$$

$$= (\log 13 - \log 7) / (\log 100 - \log 30) = 0.514.$$

$$\alpha = 1.2$$

$$\text{Now } y = \alpha \cdot t^\beta = 1.2 \cdot t^{0.514}$$

$$I = dy/dt = 1.2 \times 0.514 \times t^{0.514 - 1} = 0.617 t^{-0.486}$$

**Rainfall simulator:** In this small plot of land of about 2m x 4m size, is provided with a series of nozzles on the longer side with arrangements to collect and measure the surface runoff rate. The specially designed nozzles produce raindrops falling from a height of 2m and are capable of producing various intensities rainfall. The terminal velocity of rainfall is assumed to be close to raindrops through a height of 5–6m may be the ideal situation. Rainfall intensities of 44.5 mm/h or multiple of it are generally created under such conditions. Arrangement is made to collect the runoff from the plot, which can be measured ( $S_{RD}$ ). Prior to the experimental a run is made covering the plot with a polyethylene sheet to know the average rate of rainfall ( $P_d$ ). Test run starts after removal of the polythene cover from the field and continues till a steady state of runoff from the plot is obtained. The following water budget equation is used to estimate infiltration rate from the experiment.

$F_d = P_d - S_{RD} - S_{ol}$ , where  $F_d$  is the depth of infiltrated water in mm,  $P_d$  the simulated measured rainfall depth in mm,  $S_{RD}$  the measured surface runoff depth in mm,  $S_{ol}$  the depression storages, surface detention, abstraction and other losses in mm. When steady state is reached, the analytical run is carried out, the volume  $S_{ol}$  being no more effective, the constant rate of infiltration is calculated from the relation  $F_d = (P_d - S_{RD})$ . When rainfall stops, runoff from the plot continues and the values of depression storage plus surface detention can be measured from the recession between stop of rainfall and the last drop of water flowing out of the plot as runoff.

**Block furrow method:** The method consists of blocking the furrows at two ends, unit distance apart so as to assess the volume storage difference in the furrow in relation to time. The instrument includes a float mechanism and a water stage recorder. In this method, PVC plates are inserted at a spacing of 1 m. Water is applied from the tank into furrow regulating it in such a way that water level in furrow remain constant through out the test. Thus, water test from the furrow due to infiltration is refilled by supply tank. To measure the rate of infiltration the fall of the level of water in the supply tank is measured by piezometer for a fixed interval of time. The volume of water lost can also be calculated for the same interval of time. Equivalent depth of infiltration is obtained by multiplying the difference of piezometric reading with ratio of water supply to water applied.

$$\text{Volume of water supplied} = \pi r^2 h .$$

$$\text{Volume of water applied} = \text{spacing of furrow in cm} \times 100$$

$$r = \text{radius of supply tank in cm.}$$

A graph can be plotted between the rate of infiltration and cumulative time, and also between the depth of water in tank and time. The depth versus time curve will be a parabola.

Let the equation of curve be  $y = \alpha . t^\beta$ . To obtain rate of infiltration  $I = \frac{dy}{dt} = \alpha . \beta . t^{\beta-1}$

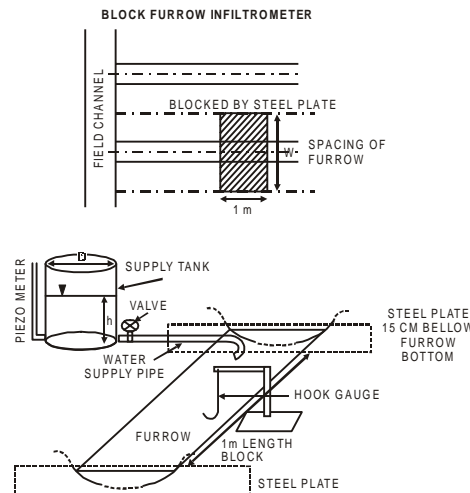

Fig. 4.14 Block furrow infiltrometer.

**70** Water Management

#7 Following data collected on a farm for blocked furrow infiltrometer test. Diameter of a drum of supply tank = 30.8 cm and spacing of furrows are 70 cm; obtain the equation for cumulative infiltration depth  $y$  versus cumulative time  $T$  and rate of infiltration.

<i>Time Hr-min</i>	<i>Piezometer Reading in Supply Tank (cm) 26.8</i>	<i>Remark</i>
9 – 06	26.8	
9 – 08	21.1	
9 – 10	15.0	
9 – 12	11.2 / 25	Refilling
9 – 15	17.1	
9 – 18	10.4 / 29.5	Refilling
9 – 20	26.3	
9 – 25	15.7	
9 – 30	7.3 / 29.1	Refilling
9 – 40	12.8 / 28.2	Refilling
9 – 50	13.4	
9 – 55	5.1 / 29.9	Refilling
10 – 00	22.7	
10 – 10	9.0 / 24.5	Refilling
10 – 25	5.3 / 26.5	Refilling
10 – 40	8.5 / 28.4	Refilling
10 – 55	6.6 / 28.5	Refilling
11 – 10	12.5 / 26.7	Refilling
11 – 30	3.2 / 30.0	Refilling
11 – 50	6.4	

**Solution:**

<i>Time Hr – min</i>	<i>Diff in Minute</i>	<i>Cumulative Time t (min)</i>	<i>Piezometer Reading (cm)</i>	<i>Difference H (cm)</i>	<i>Equivalent Depth of Infiltration (cm)</i>	<i>Cumulative Depth of infiltration, y (cm)</i>	<i>Rate of Infiltration, I (cm/hr)</i>	<i>Remark</i>
<b>1</b>	<b>2</b>	<b>3</b>	<b>4</b>	<b>5</b>	<b>6</b>	<b>7</b>	<b>8</b>	<b>9</b>
9-06	–	–	26.8	–	–	–	–	
9-08	2	2	21.1	5.7	0.607	0.607	18.21	
9-10	2	4	15.0	6.1	0.65	1.257	19.5	
9-10	2	6	11.2/25.0	3.8	0.40	1.657	12.0	Refilling
9-15	3	9	17.1	7.9	0.84	2.497	16.8	
9-18	3	12	10.4/29.5	6.7	0.713	3.21	14.26	Refilling
9-20	2	14	26.3	3.2	0.34	3.55	10.2	
9-25	5	19	15.7	10.6	1.13	4.68	13.56	
9-30	5	24	7.3/29.1	8.4	0.89	5.57	10.68	Refilling
9-40	10	34	12.8/28.2	16.3	1.73	7.30	10.38	Refilling
9-50	10	44	13.4	14.8	1.57	8.87	9.42	
9-55	5	49	5.1/29.9	8.3	0.88	9.75	10.56	Refilling
10-00	5	54	22.7	7.2	0.76	10.51	9.12	
10-10	10	64	9.0/24.5	13.7	1.46	11.97	8.76	Refilling
10-25	15	79	5.3/26.5	19.2	2.04	14.01	8.16	Refilling
10-40	15	94	8.5/28.4	18.0	1.92	15.93	7.68	Refilling
10-55	15	109	6.6/28.5	21.8	2.32	18.25	9.28	Refilling
11-10	15	124	12.5/26.7	16.0	1.70	19.95	6.80	Refilling
11-30	20	144	3.2/30.0	23.5	2.50	22.45	7.50	Refilling
11-50	20	164	6.4	23.6	2.51	24.96	7.53	

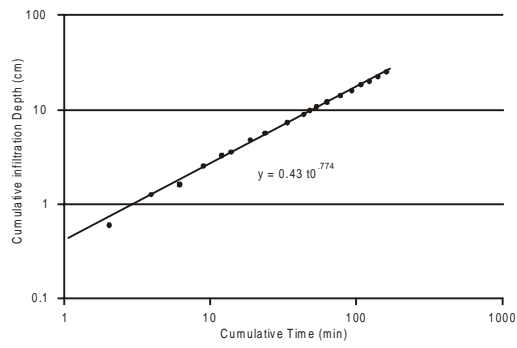

Figure # 7(i)

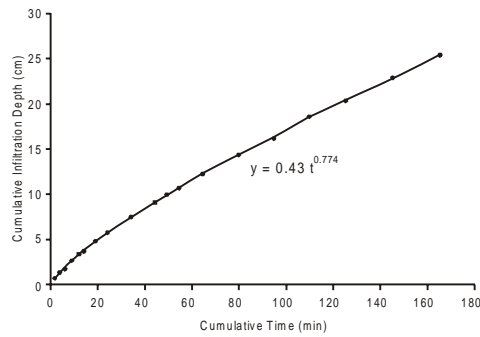

Figure # 7(ii)

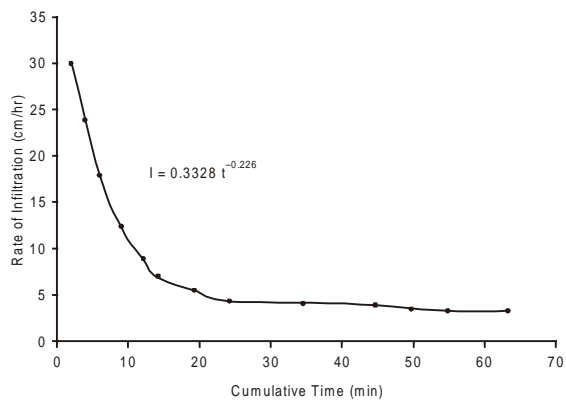

Figure # 7(iii)

$$\text{Volume of water supplied from supply tank} = \pi r^2 h \quad (1)$$

$$\begin{aligned} \text{Volume of water required} &= y' \times w \times L \\ &= y' \times 70 \times 100 \end{aligned} \quad (2)$$

Equating equation (1) and (2)

$$\pi r^2 h = y' \times 70 \times 100$$

$$\text{Therefore,} \quad \pi \times (15.4)^2 \times h = y' \times 70 \times 100$$

$$\text{Therefore,} \quad y' = \frac{\pi \times (15.4)^2 \times h}{70 \times 100} = 0.1064 h$$

Now from graph of cumulative depth versus cumulative time,  $y = \alpha \cdot t^\beta$

$$\text{Therefore,} \quad \log y = \log \alpha + \beta \log t$$

$$Y = c + mx$$

$$\text{From log - log graph equation,} \quad I = \frac{dy}{dt} = \alpha \cdot \beta \cdot t^{\beta-1}$$

$$\text{From graph,} \quad \beta = \frac{\log y_1 - \log y_2}{\log x_1 - \log x_2} = \frac{\log 50 - \log 10}{\log 400 - \log 50} = 0.774$$

$$\alpha = 0.43$$

$$\text{Now,} \quad y = \alpha \cdot t^\beta = 0.43 \cdot t^{0.774}$$

$$I = \frac{dy}{dt} = 0.43 \times 0.774 \times t^{0.774-1} = 0.3328 \times t^{-0.226}$$

**Inflow-outflow method:** This method is also known as volume balance method. It is considered to be the most satisfactory one because it gives the average infiltration value by compensating various errors, inherent in the furrow, arising out of soil heterogeneity, furrow cross sectional difference, cracks and puddling effects. The cylinder infiltrometer is used for basin and border irrigation. Inflow-outflow method is most conventional for furrow.

In this method, the furrow is divided into a number of sections and Parshall's flumes or other suitable water measuring devices are installed at each station to measure the flow rate. The furrow cross sectional profile is determined at the representative locations in the test section with a point gauge before admitting water. The furrow spacing is measured from the center of the water in the test section and the depth of flow at different points at definite time intervals are also reckoned. From the above measurements, it is possible to obtain the furrow cross sectional area and wetted perimeter. The average value of wetted perimeter multiplied by length of the test section gives the wetted area. Furrow irrigation is determined by following relationship.

Accumulated Infiltration = Accumulated Inflow – Accumulated Storage.

$$\text{Accumulate depth on depth} = \frac{\text{Accumulated infiltration}}{\text{Wetted area of cross section}}$$

With the help of point gauge of even section, profile of head and sides is to be calculated. The point gauge is called the *profilometer*. Consider average profile for experiment because at particular section we are not able to know the exact depth and the depth is also not constant throughout the length of furrow.

Now, in order to get relationship between the infiltration depth (y) and time (t) the power relationship is assumed between them.

$$y = \alpha.t^\beta$$

$$\log y = \log \alpha + \beta \log t$$

Plot the graph of y versus t on log – log graph paper. The intercept on y axis gives log (α) and slope of the line gives β.

After getting equation of infiltration depth, infiltration rate can be found out as

$$I = \frac{dy}{dt} = \alpha.\beta.t^{\beta-1}$$

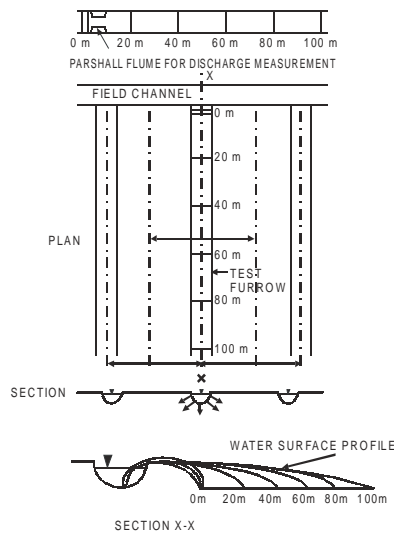

**Fig. 4.15 Inflow-outflow method.**

#8 Following data is obtained from a typical furrow. Compute accumulated infiltration depth and infiltration rate equation.

Stream Size (lit/min)	Distance (m)	Advance Time 't' (min)	Wetted Perimeter (cm)	Furrow Cross-sectional Area Corresponding to Average Depth of Flow (cm <sup>2</sup> )
	20	3.5	21.3	93.00
74	40	6.83	21.7	90.50
	60	11.75	22.1	91.50
	80	17.41	22.5	92.50
	100	23.75	22.9	92.40
	110	26.83	23.2	91.91

**Solution:**

Stream Size (lit/min)	Distance (m)	Advance Time 't' (min)	Accumulated Inflow (lit) $q \times t$	Wetted Perimeter (cm)	Furrow Cross-sectional Area Corresponding to Average Depth of Flow (cm <sup>2</sup> )
1	2	3	4 (1 × 3)	5	6
	20	3.50	259.00	21.3	93.00
74	40	6.83	505.42	21.7	90.50
	60	11.75	869.50	22.1	91.50
	80	17.41	128 8.34	22.5	92.50
	100	23.75	1757.50	22.9	92.40
	110	26.83	1985.42	23.2	91.91

Accumulated Storage (lit)	Wetted Area (cm <sup>2</sup> )	Accumulated Infiltration volume (lit)	Accumulated Infiltration Depth (cm)
7 (2 × 6) × 100/1000	8 (5 × 2 × 100)	9 (4 – 7)	10 (9/8 × 100)
186	42,600	73	1.71
362	86,800	143.42	1.65
549	132,600	320.50	2.41
740	180,000	548.34	3.04
924	229,000	833.50	3.64
1011.01	255,200	974.41	3.82



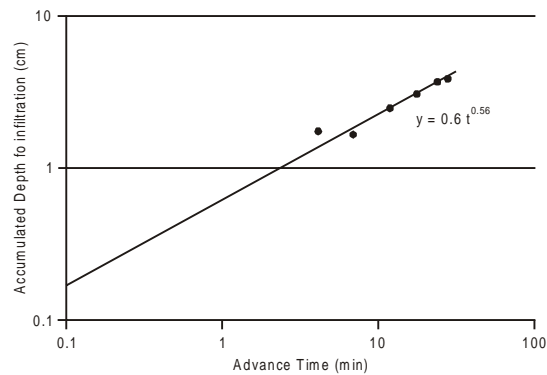

Figure # 8 (i)

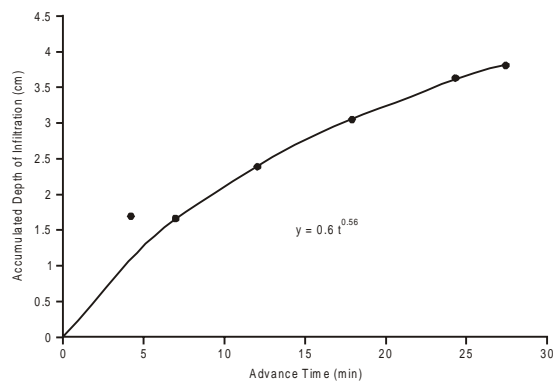

Figure # 8 (ii)

**Sample calculation:**

1. Accumulated inflow =  $q \times \text{advance time} = 74 \times 3.5 = 259.0$  lit
2. Accumulated storage = cross-sectional area  $\times$  distance =  $93 \times 20 \times 100 = 186000$   $\text{cm}^3 = 186$  lit
3. Wetted area = wetted perimeter  $\times$  length from upstream end of furrow =  $21.3 \times 20 \times 100 = 42600$   $\text{cm}^2$
4. Accumulated infiltration = accumulated inflow - accumulated storage =  $259 - 186 = 73$  lit =  $73,000$   $\text{cm}^3$
5. Accumulated depth of infiltration = (accumulated infiltrated volume/wetted area) =  $(73,000/42,600) = 1.71$  cm

$$y = 0.6 t^{0.56}$$

$$\text{Take } t = 6.83$$

$$y = 0.6 (6.83)^{0.56} = 1.76 \text{ from graph and from table}$$

$$y = 1.65$$

$$\text{per cent error} = [(1.76 - 1.65)/1.76 \times 100] = 6.25 \%$$

$$\text{equation } y = 0.6 t^{0.56}$$

# 5

# WATER CONSERVATION

## 5.1 INTRODUCTION

The term conservation has been widely used in different fields. Economists consider conservation as managing the resources in such a way that maximum human needs will be satisfied. The water conservation can be considered as prevention against loss of waste. Technically, this can be achieved by putting the water resources of the country for the best beneficial use with all the technology available in hand. As far as India is concerned, in most of the places, there is a rainfall during monsoon months and very little rain during other months. The monsoon rainfall often comes in pattern, which leaves some drought period in between. For this drought period, conservation of water is necessary. Conservation of water in drought prone area will help in providing more irrigation for development of agricultural potential of these areas.

## 5.2 DEVELOPMENT OF NEW SUPPLIES

In order to effectively use and conserve limited water resources, supply oriented measures such as better use of existing supplies and development of new supplies are required to be taken up. Various techniques developed in different parts of the world for better use of existing supplies and developing new supplies are:

1. Rain water conservation,
2. Effective use of surface runoff,
3. Improving groundwater storage, and
4. Soil conservation

**Rain Water Conservation:** The rainwater conservation techniques for better use of existing supplies practiced at different parts of the world are as follows

- (i) **Rainwater harvesting:** The uncertain rain in drought prone area, if harvested over large area, can yield considerable amount of water. If 1 mm of rain falls on one-hectare area, it leads to harvesting of 10,000 liters of water. Rainfall harvesting is very convenient method for those areas having as less as 50 to 100 mm average annual rainfall. For rain harvesting use of soil cover in the form of plastic and rubber sheets, land alteration, reducing soil porosity by chemical treatment can also be practiced.

- (ii) **Rainfall cistern system:** In a rainfall cistern system, runoff collected from roof tops of the houses is used for various purposes including irrigation in droughts of short duration of 10 to 15 days.
- (iii) **Weather modification:** Modifying suitable clouds artificially can augment the rainfall in areas. Weather modification can be of much use when shortage in water supply is acute. Even a small contribution from seeding is helpful and economically acceptable in such critical situations.

**Effective Use of Surface Runoff:** Manipulation of vegetative covers, soils, snow and other measures in a watershed can jointly increase water yield. Water losses from large bodies can be minimized by using some chemicals like aliphatic alcohols, acetyl alcohol etc. Floating blocks of wax and certain light material like rubber can also be used as evaporation suppressant. In one such experiment at Stevens Creek Reservoir in Australia hexadecyl alcohol chemically known as acetyl alcohol was used. Though this chemical is cheaper and does not impart any colour, odor, or biological activity to the water still there is a scope for research in this field. At Aji – I reservoir near Rajkot in Gujarat state of India, acetyl alcohol in the form of powder was used, which gave very successful results. Due to the above treatment, the average saving in evaporation losses was found to be of the order of 16.5%.

**Improving Groundwater Storage:** The groundwater is used by pumping from aquifers. For groundwater, a hydrologic equilibrium must exist between all water entering and leaving the basin or aquifer. The equilibrium can be maintained by artificial recharge. In artificial recharge, it is tried to spread water on more and more area for deep percolation into the ground. The spreading of water may be done by flooding water in a relatively flat area, constructing basins by excavation or by construction of dykes or small dams.

**Soil Conservation:** Erosion is the detachment and transportation of the soil, which will affect the plant growth. It necessitates need of soil conservation. Soil and water conservation of agricultural land are somewhat same which include contour farming, mechanical measures such as contour bunding, graded bunding, bench terracing on steep slopes and run off harvesting storage.

### 5.3 REDUCING DEMAND OF WATER

Changing crop pattern may reduce water demand in agriculture. In industry, it can be reduced by changes in technology product.

**Reducing Evapotranspiration:** This aspect is very important in drought prone area. Placing moisture tight barriers or water retardent mulches on the soil surface can prevent this loss. Non-porous materials such as asphalt sheets, plastic film or metal soils could be used for reducing evaporation from soil surface.

**Adjusting Cropping Pattern:** A suitable crop-breeding program should be developing for the drought prone area. Plant suitable for drought prone area should have shorter growth period, high yield capacity with less demand of water, low transpiration rate, etc.

**Improving Irrigation Practices:** Drip irrigation is suitable technique in water scare area as well in undulating area. In drip irrigation amount of water can be adjusted to the soils depending upon type of soils, crop and climatic conditions.

**Reduction of Seepage:** By lining of canals and channels seepage can be reduced, leading to saving of water. According to US Department of the Interior Bureau of Reclamation, different lining like hard surface lining, buried membrane linings, earth linings can be practiced for this purpose.

#### 5.4 EVAPORATION CONTROL

The problem of evaporation control from a storage reservoir is quite complex and needs careful considerations. Huge quantities of water are lost from storage reservoirs by evaporation every year. With the rapid increase in the development activities of the country, the need for conservation of stored water is keenly felt. The huge cost at which the storage reservoirs are built, calls for minimizing evaporation to the maximum extent possible. The need for minimization of evaporation loss is even greater in the case of semi-arid and arid regions. The loss of water from free surfaces of reservoirs assumes great importance especially when rains fall in an arid region. The meteorological factors like, temperature of surface water, dew point temperature of air, wind movement, and atmospheric pressure, which are responsible for evaporation, cannot be controlled under normal conditions and at reasonable cost.

**Methods for Controlling Evaporation:** Different methods for controlling evaporations are broadly classified as: (i) Physical, (ii) Biological and (iii) Chemical method.

**Physical Methods:** Physical methods can be classified as follows:

- (a) Planting of trees all around the lake or reservoir to reduce the wind velocity. By planting trees all around the tank, one can reduce the wind velocity, which can blow on the surface of the tank effecting reduction in evaporation. Moreover, the leaves of the trees due to transpiration can create humid air above the water surface of the tank, thus helping to reduce the water evaporation.
- (b) Partitioning the bigger tanks into smaller areas so that wind blowing on these areas is cut down and the evaporation reduced. If one can make smaller compartments having smaller areas the wind, which is blowing on the surface of the tank, gets broken, thus reducing the evaporation of water.
- (c) Tank or reservoir can be covered with suitable material to reduce the evaporation. Here one can make use of plastic balls, which can float on the water surface, or one can use plastic sheets to reduce the water evaporation. This may not be economical for larger reservoirs and sometimes water may get polluted.
- (d) Construction of tanks of high depth and smaller water surface areas. This method is very useful for drought prone areas water is pumped to appropriate deeper pockets so that the surfaces exposed to evaporation are effectively reduced. Such a method was successfully tried for Lake Worth in Texas (1988). There is thus a great scope of such technique in all tropical drought prone or arid areas. In Gujarat (India), this method was tried for Nyari Lake near Rajkot in year 1987-88.
- (e) Construction of underground storages or reservoirs in place of surface storage or reservoirs. This method involves planning use of underground storages for water rather than overground storages. This can certainly be done with great advantage in cases

where aquifers for such storages are available and these do not entail higher lateral dispersion losses. Subsurface dams can also be constructed in such schemes to prepare limited aquifers and thereby raise the level of storage, reducing subsequent pumping. Subsurface dams or underground check dams have been constructed across streams or rivulets in water deficient areas to hold groundwater and recharge the adjoining limited aquifers. One of the outstanding applications of this method was recharge of the aquifer (adjoining Talaji rivulet near the town Talaji, Gujarat, India) where significant water level rises were registered after the limited monsoons. The main advantage of this method is that loss of valuable lands and forest areas due to surface submergence can be avoided. Unlike in the case of surface storages, the evaporation losses are minimal. This method consists of managing the available reservoir in conjunction with other reservoirs by drawing water for consumption such that the aggregate area exposed to evaporation especially in summer months is minimum.

- (f) Minimizing exposed water surfaces through storage management or integrated reservoir management.

**Biological Methods:** There are many locations requiring phreatophyte control to reduce non-beneficial consumption of water by plant growth of little economic value. Salt cedar, willows and cottonwoods not only consume large amount of water but they also aggravate meandering thus causing further water loss. Techniques of phreatophyte control are being perfected and continued research proposes further improvements. A major difficulty however is that effective control generally requires repeated treatment with resulting high costs. Possibly this may be relieved by management techniques that will result in grasses becoming established in place of the phreatophytes.

**Chemical Method:** These methods although useful to certain extent and have been used successfully in some areas, cannot be used for the entire water surface available in the country. One of the novel methods used for reducing the evaporation from water surface is the chemical method. There are some compounds called *long chain fatty alcohol*, which when put on water surface spread spontaneously and form a monomolecular film. This technique of spreading monomolecular films for suppressing water evaporation has been tried on a large scale in Australia for the first time in early 50s using monomolecular films of cetyl alcohol. This water evaporation retardant was also called hexadecanol having a formula  $C_{16}H_{33}OH$ . This is a white waxy crystalline solid compound generally available in flakes or powder form and is derived from tallow sperm oil. Its specific gravity 0.85 and melting point  $50^{\circ}C$ . The monomolecular film formed by hexadecanol on water surface is only about 0.015 micron in thickness. Another long chain fatty alcohol called stearyl alcohol having a formula  $C_{18}H_{37}OH$  is also used with cetyl alcohol. Cetyl alcohol was mainly used as a retardant. In some cases cetostearyl alcohol i.e. mixture of cetyl and stearyl alcohols were used as effective evaporation retardants.

These chemicals can be dispersed in different forms:

- (i) Solution using suitable solvents.
- (ii) Fine powder, as molten liquids or as slurry.

- (iii) Emulsion or suspension.
- (iv) Pellets.

**Solution:** Different countries have adopted different solvents for the preparation of the solution of cetyl alcohol. Studies have indicated that mineral turpentine is the most suitable solvent. Known quantity of cetyl alcohol in powder form is added to a gallon of mineral turpentine to obtain desired concentration, say, one pound in two gallons of turpentine, etc.

**Fine Powder:** Another form of application of the chemical is in powder form. Cetyl alcohol, which is supplied in the form of big lumps, has to be pulverized and made into fine powder before it could be applied to water surface. The big lumps are broken to small pieces by means of hammer. The pieces are then fed to a powder-grinding machine. The spacing of the grinder plates is adjusted to get the powder of required fineness.

**Emulsion or Suspension:** The use of the solvent, mineral turpentine is costly and dispensing the chemical in emulsion form has been tried. The emulsion is prepared by adding known quantity of cetyl alcohol in powder form to two gallons of water containing small quantity of soap or chekol or surfactants and heating the same to 67°C when a paste is formed. Water is then added to give the required concentration.

If the water is used for the preparation of emulsion is impure, that is, if it contains large quantity of bacteria or carbonaceous dust, oil content, etc., emulsion cannot be formed and there will be only lumps of cetyl alcohol with impurities. Hence, tap water is quite necessary for the preparation of emulsion.

Cetyl alcohol in an emulsion or solution form can be very successfully dispensed by shore dispensers and raft dispensers. It can also be supplemented by dispensing from boat. The shore dispensers are placed along upwind side. Application may have to be made daily to maintain the film throughout the period of experiment.

**Pellets:** Pellets can be applied by hand or from constant feed chambers. But the experiments have proved that the use of pellets is not encouraging due to various factors like the mineral offering relatively small surface exposure for the generation of the film and formation of algae, abrasion with gauge raft etc.

**Comparison of Different Methods:** Cluff and Resnick have drawn the under mentioned comparisons between the dispensing of long chained alcohol in solid, powder, solution and slurry forms.

The advantage when applied, as powder is that no additives are required which may increase the cost or may be toxic to fish and animal life. Although easy to apply in the form of solid, the spreading rate of solid material is too slow to be of practical value in the formation of an effective monolayer. Other disadvantages are: (i) excessive point application of powder to achieve the same spreading rate as emulsion and solution, and (ii) the problems encountered in the development of a simple wind activated dispenser for powder within economic range for use of small reservoir.

The spreading rate of solid material decreases with increasing chain length and decreasing temperature.

Application in the form of solution has several advantages: (i) spreading rate is fast; it is independent of temperature and slightly affected by increasing chain length of alcohol, (ii) relatively small amounts of solution are needed to generate a film, and (iii) being in liquid form, continuous application is simplified.

The disadvantages are: (i) the solution cannot be used in late full winter and spring, and (ii) the cost of the solvent would be prohibitive unless suitable wind activated dispensers could be developed.

In emulsion form, the advantages are: (i) it yields a satisfactory spreading rate and high evaporation suppression ability, (ii) the unit material cost is much lower than in solution, and (iii) ease in dispensing with a wind activated screw dispenser. The disadvantages are: requirement of an emulsifier which is to be cleared by health authorities, and total cost of material and transportation might be higher than for power.

### ***Monolayer Properties of Alcohols and Alkoxy Ethanol***

**Film Pressure Area Isotherms:** All the alcohols and alkoxy ethanol have been obtained in pure form. This property can give us an idea whether particular film forms condensed film or not and also gives various two dimensional phase changes especially liquid condensed to solid state.

**Rate of Spreading and Equilibrium Spreading Pressure:** These properties are important to understand whether these compounds spread reasonably fast or not and also the equilibrium pressure obtained should be high. It has been observed that alkoxy ethanol exhibit high rate of spreading and equilibrium spreading pressure as compared to corresponding alcohols.

**Collapse Pressure:** The higher the collapse pressure, the better is the stability of the film. It has been observed that collapse pressure of alkoxy ethanol is higher than that of the alcohols.

**Mixed Monolayer:** Instead of using single component, we can use mixture of two components so that the mixed monolayer formed by these two components may be better in terms of water evaporation retardation. In practice, it may not be economical to conduct experiments with pure compounds or sometimes mixed components may be naturally available, under these circumstances it is better to study the behaviour of mixed monolayer.

From exhaustive study, it has been concluded that the alcohol mixtures viz.  $C_{16} - OH + C_{18} - OH$  (1: 3) seem to be better than other alcohol mixed films as regards evaporation reduction.

Amongst the alkoxy ethanol  $C_{18} - OC_2H_4OH + C_{22} - OC_2H_4OH$  (1: 9) seems to be the best monolayer from the point of view of evaporation retardation as compared to alcohol mixtures and other alkoxy ethanol mixtures.

**Formation of Monolayer:** The process of film formation is as follows — the OH radical of molecule of cetyl alcohol is attracted to the water, which also contains OH radicals. The molecules leave the solid spontaneously to form a monolayer floating on the water surface. This OH radical is immersed under water and the rest of the molecules stand on the surface. These molecules form the film. It has been found that maximum retardance of evaporation

will be at a pressure 40 dynes/cm. Riedel used monolayer of fatty acids and found that the evaporation reduction depends on the film pressure or surface concentration. R. McArthur and Durham from their studies demonstrated that the efficiency of the monolayer to reduce evaporation increased with dosage as expressed in multiples of the theoretical quantity needed to form monolayer up to a maximum value after which a constant efficiency was reached.

### ***Polymorphism***

Polymorphism is the property possessed by certain chemical compounds of crystallizing in several forms, which are generally different. Two properties of long chain  $n^{3/4}$  alcohols in the application of the materials to reservoir surfaces for retarding evaporation are the spreading rate of the monolayer as it forms from the floating alcohol crystal and permeability of the monolayer to water vapour molecules. Both these properties depend in part on the chain length of the alcohol. The spreading rate also depends on which polymorph of the alcohol is present. The polymorphic changes of alcohols, in turn, occur at temperature, which depends on the chain length.

### ***Film Pressure***

The film pressure should be of the order of 40 dynes/cm because evaporation reduction is the greatest in that range and substantially decreased effectiveness results from lower film pressure. Maintenance of optimum film pressure with additional material is complicated by temperature effect. To obtain high efficiency in evaporation reduction, it is necessary that, as the temperature changes, first to generate a fully compressed layer at the highest possible degree of compression by continuous supply of fresh retardant material to compensate for loss due to attrition, etc.

### ***Effect of Impurities***

Effective life of alkanol film depends on its continued existence in the liquid condensed state. Bodies that cause solidification on the film are therefore detrimental. Dust, carbonaceous matter and possibly algae solidify on the film and if the contaminants have sufficiently high specific gravity, they cause the film to sink.

The film destroying impurities most commonly met in practice are proteins arising from aquatic life and carbonaceous dust. The spreading front of the solvent, if alcohol is dispensed in solution form, helps to clean protein deposits off the water surface. The effective life of the monolayer is, therefore, shorter on the reservoir water than on tap water.

### ***Effect of Wind***

There are several factors influencing the survival and effectiveness of monolayer of which wind can be considered the most important. The rate of movement of monolayer is a function of the wind velocity. With winds 24 to 32 km/h, it appears impracticable to maintain any appreciable coverage. On the basis on the experiments conducted in Australia, it is stated that for wind up to 8 km/h evaporation saving has been 40% or more. When wind velocity is 24 km/h or more, no saving can be effected.



## 5.5 EQUIPMENTS

Following are the main equipments required:

**Floating Rafts:** This dispensing unit consisting of a drum of capacity 181.83 liters installed on a floating raft 2.49 m × 2.49 m in size (Fig 5.1). The raft is constructed of light material, about 38.10 mm thick over six floating drums. Attached to the floating raft is a frame carrying a drum of capacity 18.18 liters, which is kept floating on the surface. The delivery unit comprises of a control valve and a delivery tube, which draws the solution from the 181.84 liters drum, with its delivery and kept 76.20 – 152.40 mm below the water surface by the float drum of 18.18 liters capacity. The number of raft dispensers depends upon the shape and extent of water spread.

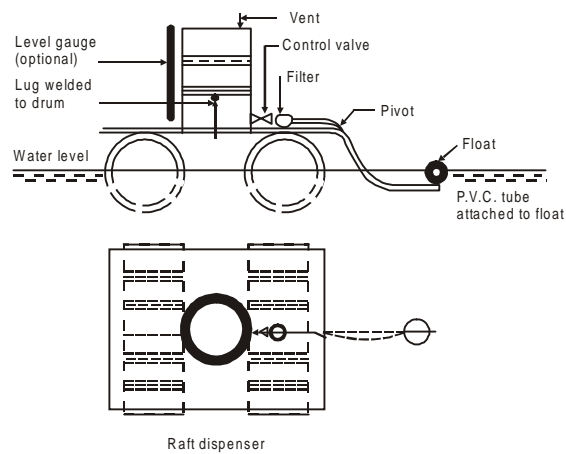

**Fig. 5.1** Floating raft.

**Shore Dispensing Unit:** This type of dispensing unit consists of 181.84 liters drum installed on a portable stand made of mild steel angles (Fig 5.2). These are placed on the periphery of the water spread to deliver the solution at the shoreline. The position and location of these depend on extend of water spread and direction of wind.

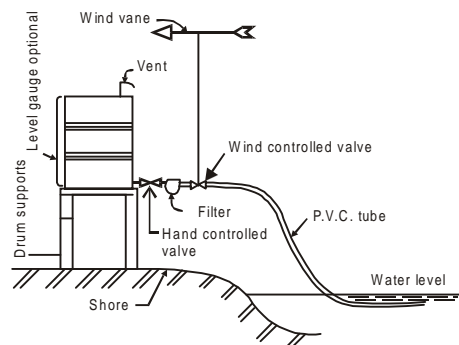

**Fig. 5.2** Shore dispensing unit.

**Boat:** One ordinary rowboat or motorized one for towing the floating rafts, and for going over the water spread for testing the surface pressure is required.

**Meteorological Equipments:** Temperature of air and humidity are measured by using maximum and minimum thermometers, wet and dry bulk thermometers or any other type of hygrometer. These thermometers being housed in standard Stevenson screen. Anemometers either direct reading or recording type, measure temperature of water.

## 5.6 STUDIES ON EVAPORATION CONTROL

The problem of evaporation control from a storage reservoir is quite complex and needs careful considerations. Huge quantities of water are lost from storage reservoirs by evaporation every year. With the rapid increase in the development activities of the country, the need for conservation of stored water is keenly felt. The huge cost at which the storage reservoirs are built, calls for minimizing evaporation to the maximum extent possible. The need for minimization of evaporation loss is even greater in the case of semi-arid and arid regions. Loss of water from free surfaces of reservoirs assumes great importance especially when rains fail in an arid region. If the lake is meeting with the entire needs of water supply of a town the shortage can cause scare. Meteorological factors causing evaporation cannot be controlled by human beings. The only practicable alternative is to cover the water spread with a self-supporting membrane. Researchers have tried various materials to create such membranes, cetyl and stearyl alcohols forming strong monolayer have been amongst the foremost. They require organic solvents like petrol, white spirit, mineral turpentine, synthetic thinners, kerosene, and indicator oil. The alcohols can be dispensed in solid or liquid forms.

India, which lies partly in tropical and partly in sub-tropical region, is characterized by irregular and unequal rainfall during the precipitation months. The frequent monsoon failure and existence of a large area of arid regions in the country has increased strain on the available surface water. To combat this problem, Research Stations in the country have conducted field and laboratory experiments for controlling evaporation for the past few decades. A review of the work done by these Research Stations is given as under.

**Case Study – Kukkarahalli Tank and Khodiyar Irrigation Scheme**

1.0 Name of the organization	Karnataka Engineering Research Institute, Krishnarajasagar	Junagadh Irrigation Division
2.0 Address	Karnataka Engineering Research Institute, Krishnarajasagar, India	Junagadh Irrigation Division, Junagadh, India
3.0 Name of reservoir	Kukkarahalli Tank	Khodiyar Irrigation Scheme
3.1 Total capacity at (a) FRL (b) Sill level	(WS 66.77 Ha) Max depth 10.67m ----	38.22 Mm <sup>3</sup> Nil
3.2 Levels at (a) 75% Capacity (b) 50% Capacity	Not available Not available	RL 24.16 Mm <sup>3</sup> RL 16.11 Mm <sup>3</sup>
4.0 Total losses including seepage loss	2.893 Mm <sup>3</sup> /day	4.26 Mm <sup>3</sup>
4.1 (a) Method of estimation of evaporation loss (b) Comparative study of different method	which methods have been adopted at Karnataka Research Institute, Krishnarajasagar	By pan evaporimeter By standard of CDO
4.2 Method for estimation of seepage losses	Only savings effected per day has been found out by eliminating seepage loss	By V Notch
5.0 Evaporation loss (a) In winter season (b) In summer season	Nil Only savings effected per day has been found out	2.688 Mm <sup>3</sup> in Rabi season 1.578 Mm <sup>3</sup> after Rabi season
6.0 Seepage loss at (a) FRL (b) Intermediate level	Seepage loss has been eliminated —	0.05m per month (CDO Standard) 0.05m average per month
7.0 Retardant used for	Cetyl alcohol surface treatment with reduction of evaporation loss with method and experience	Cetyl alcohol chemical retardant
8.0 Saving in evaporation loss	Not available	10% (3.22 Mm <sup>3</sup> )
8.1 % of total capacity of reservoir		
8.2 % of summer capacity of reservoir	Not available	26.29%
9.0 Year and period of study	Feb, April, May 1962	28/4/1988 to 14/6/1988
10.0 Meteorological data pertaining to period of study	Not available	Not available

**Case Study – Malan Irrigation Scheme and Udaisagar Lake**

1.0 Name of the organization	Water Resources Department, Gujarat	Hindustan Zinc Limited
2.0 Address	Bhavnagar Irrigation Division, Pan Wadi, Bhavnagar, India	Hindustan Zinc Limited, Zinc Smelter, Udaipur, India
3.0 Name of reservoir	Malan irrigation Scheme	Udaisagar lake
3.1 Total capacity at (a) FRL (b) Sill level	11.44 Mm <sup>3</sup> /FRL 104.26 m 0.00 mcft 93.90 m	29.73 Mm <sup>3</sup> / FRL 551.83 m 3.54 Mm <sup>3</sup> at 544.43 m
3.2 Levels at (a) 75% Capacity (b) 50% Capacity	103.26 m 102.03 m	550.75 m 549.50 m
4.0 Total losses including seepage loss	0.65 Mm <sup>3</sup>	0.7618 Mm <sup>3</sup>
4.1 (a) Method of estimation of evaporation loss (b) Comparative study if different method	Thin film by Cetyl stearyl alcohol Not done	Pan evaporation measurement Not done
4.2 Method for estimation of seepage losses	Assumed 0.12% per day	Seepage is nil being impervious bed of the lake
5.0 Evaporation loss (a) In winter season (b) In summer season	1.26 m without WER chemical, and 1.02 m using WER chemical	0.2685 Mm <sup>3</sup> (21/1/87 to 28/2/87) 0.4933 Mm <sup>3</sup> (1/3/87 to 15/6/87)
6.0 Seepage loss at (a) FRL (b) Intermediate level	Not available 0.28 m in summer	Not available Here seepage log has to be given not the capacity
7.0 Retardant used for reduction of evaporation loss with method and experience	Cetyl alcohol in powder form (dusting from boat)	Retardant used was ACIOL TA – 1618 WER
8.0 Saving in evaporation loss		
8.1 % of total capacity of reservoir	Not available	0.80% (0.22772 Mm <sup>3</sup> )
8.2 % of summer capacity of reservoir	9.15%	Not available
9.0 Year and period of study	1/3/1988 to 31/5/1988	21/1/87 – 15/6/87
10.0 Meteorological data pertaining to period of study	Wind velocity: 11.17 km/h Temperature: Max. 1800 hrs – 37.87°C D B Temperature 800 hrs – 28.50°C 1800 hrs – 34.70°C W B Temperature 800 hrs – 23.00°C 1800 hrs – 27.00°C 45°C Rainfall - Nil	Wind velocity – 15 – 20 km/h Min & Max Temp – 6°C & 46°C  Relative humidity – 14% to 60% Pan evaporation – 10% to 47% Wind direction – Towards east Lake temperature – 5°C to

Following table gives a list of countries where Cetyl alcohol was successfully used.

Sr. No.	Country	Observations	Percentage Saving Effected	Remark
1	Australia	Reservoir of areas from 2 to 20 acres	20 to 70%	
2	Japan	Evaporation pans over a period of three months in summer	53%	OED paste
3	USA	USA Laboratory experiments	13 to 60%	
4	Australia (CSIRO)	—	52%	
5	USA	100000 gallons capacity aerator tank 30 feet diameter and 14 feet deep	11%	Sept 14 to 23 & Oct 11 to 18
			33%	August 30 to Sept 7
6	South Dakota	Pactola	14%	
7	Nairobi	Reservoir area 6.5 acres	30%	
8	Tabora, Tanzania	Reservoir of 105 acres water spread	30%	
9	Malaya	—	11%	
10	Spain	Reservoir areas 31 acres	35%	4% solution in white spirit
			31%	35% solution kerosene

## 5.7 CONSERVATION OF SOIL MOISTURE

To appreciate the need of conserving the soil moisture, it is important to know the relation which exists between the amount of rain received, and the possible loss of this rain in ways which do not contribute to crop production. Now, the waters which fall as rain upon a field may be lost to it by running off its surface, as is too often the case on hilly farms; it may be lost by percolating downward beyond the reach of root action; or it may be lost by surface evaporation from the ground itself. As a rule, it is only that water which passes through the plant that materially contributes to its growth. However the mixture which evaporates from the surface of the soil does indirectly help the plant by leaving the chemical salt it may have held in solution nearer the surface of the ground, where it is more likely to be taken up by the roots, and in assisting that soil life which develops fertility.

### *Need of Conserving Soil Moisture*

There is hardly any productive land, which, under field conditions, can retain as much as 30 kg of water to the 100 kg of soil, unless they lie close to or below the water table. In proof of this statement the water content of several field soils 32 hours after a rain of 100 mm may be cited which fell during 4 days. The same fields had received 111 mm 20 days earlier, and during the intervening 20 days there had been a rainfall of 30 mm.

<i>Type of Soil</i>	<i>First Foot, Per Cent</i>	<i>Pounds Per cu. ft</i>	<i>Second Foot, Percent</i>
Clay soil contained	33.91	26.79	26.60
Clay loam contained	23.88	26.57	26.45
Clay loam contained	28.75	26.45	27.06
Sandy clay loam contained	26.48	25.95	25.46
Sandy clay loam contained	24.69	24.76	22.81
Sandy clay loam contained	24.61	24.12	21.44
Sandy loam contained	17.65	18.00	15.81
Sandy loam contained	17.65	18.00	14.59

### ***Saving Soil Moisture by Ploughing***

Ploughing land in the fall has a very appreciable influence on the *per cent* of water the surface 1m to 1.2 m of such soil may contain the following spring, and it is observed that a mean difference of 2.31 per cent more water in the upper loam of immediately adjacent lands ploughed late in the fall, as compared with that not ploughed, the surface of neither having been distributed. The larger quantity of water in the fall ploughed ground, in this case amounting to not less than 6 pounds per square foot, was partly due to two causes; namely, the loose, open character of the overturned soil, causing it to act as a much during the fall, and again in the spring, after the snow had disappeared; and the more uneven surface, which tended to permit more of the melting snow and early spring rains to percolate into the soil.

Late fall ploughing, leaving the surface uneven and furrows in such a direction as to diminish washing, works in a decided manner, on rolling land, to hold the winter snows and rains where they fall, giving to such fields a more even distribution of soil water in the spring. And when it is observed that heavy lands, after a dry season, seldom become fully saturated with water during the winter and spring, the importance of fall ploughing in such cases can be appreciated.

From the standpoint of large crops, which result from the best use of soil moisture, there is one thing more important for a farmer to strive for than the earliest possible stirring of the soil in the spring, after it has sufficiently dried so as not to suffer in texture from puddling. When the soil is wet, when its texture is close from the packing which has resulted from the winter snows and early spring rains, the loss of water is very rapid, as it has been pointed out; it may be more than 20 tonnes daily per acre, and this loss may extend to depths exceeding four feet.

### **5.8 SOIL MULCHES**

When the effectiveness of very thin soil mulches is measured, it is found that here; too, the lessening of the rate of evaporation may be very considerable. Thus it was found, by laboratory methods, that when the evaporation from an unstirred surface was at the rate of 6.24 tonnes per acre daily, from the same surface, when stirred to a depth of 0.5 inch and 0.75 inch, the loss was only 5.73 tonnes and 4.52 tonnes respectively. Again, when the surfaces were covered

with a fine, dry clay loam to a depth of 0.5 inch to 0.75 inch, the daily loss was then at the rate of 6.33 tonnes per acre per day for the naked surface, but only 4.54 tonnes and 2.4 tonnes for the mulches, respectively.

There is thus left no room to doubt the efficacy of dry earth mulches, as conservators of soil moisture, but it should be said that not all soils are equally effective in their power to diminish evaporation.

### 5.9 INFLUENCE OF FARMYARD MANURE ON SOIL MOISTURE

Farmyard manure has a marked effect upon the amount and distribution of soil moisture in cultivated fields. When coarse manure is plowed under, its first effect is to act as mulch to the unstirred soil, by breaking the capillary connection between it and the surface layer. The tendency, therefore, is to cause the surface soil to become drier than it would otherwise have become in the same time, and frequently to an injurious extent, especially in times of spring droughts, before seeds have germinated or young plants have developed a root system reaching into the deeper soil. On such occasions as these, the heavy roller is of service in making a better capillary connection with the unstirred subsoil.

Farmyard manure has a general tendency to leave the upper three feet of soil more moist than it would be without it, and the drier the season and more thorough the manuring, the more marked is its influence. In experiments to measure this influence under field conditions, it is found that for manured fallow ground the surface foot contained 18.75 tonnes more water per acre than adjacent and similar but unmanured land did, while second foot contained 9.28 tonnes and third 6.38 tonnes more water, making a total difference in favour of the manured ground amounting to 34.41 tonnes per acre. The largest observed difference was 72.04 tonnes in the dry season of 1891. Early in the spring, on ground manured the year before and fallow, there was an observed difference amounting to 31.58 tonnes per acre.

It is a fact long ago observed that increasing the organic matter in the soil increases its water-holding power, and this being true, it was to be expected that the surface foot would be more moist as a consequence of manuring.

#### *Influence of Vegetation*

**Organic matter:** The influence of vegetation upon infiltration and soil water storage is particularly due to the effect of organic matter on and in the soil and plant roots. Measurements have shown a positive correlation between the quantity of organic matter present in the soil and its water holding capacity. Increased soil porosity and water absorbing capacity have been found to follow forest planting in fields formerly cultivated.

**Plant roots:** Channels left by decayed roots also perform an important function in percolation and storage of water.

**Plant and animal life:** The soil under a relatively undisturbed forest and range cover is the home of much animal life. In the process of nutrition, the worms pass great quantities of soil and organic debris through their bodies, thereby together with bacterial action, promoting

humification and the incorporation of organic matter with mineral soil. All such life, plant and animal influence the moisture intake and moisture holding capacity of the soil, either directly or indirectly. Any modification of the plant cover and surface soil by cultivation, burning or overgrazing induces conditions unfavorable to the optimum development of these soil fauna and flora and results in a reduction in the capacity of the soil to take up water.

**Sheltering:** Vegetation shades the ground and minimizes wind movement. The effect tends to reduce evaporation and snow melting rates. It is found that evaporation of water from snow in forest areas may be only about one third as fast as from open areas. Also snow-melting rates have been observed to be as much as one third more rapid in the open than in the forest.

**Stream temperature:** D R Dewalle et al., (1977) have demonstrated that (i) maximum daily water temperatures near inlet in the unshaded reach increase almost linearly with distance, and (ii) farther from the inlet, maximum water temperatures increase exponentially and approach an equilibrium condition.



**This page  
intentionally left  
blank**

# 6

# RAIN WATER HARVESTING

## 6.1 INTRODUCTION

According to the National Drinking Water Mission, a village is classified as a problem village if:

- The source of water i.e., a well or hand pump is located at a distance of more than 1.4 km from habitat.
- The source dries up during the summer months.
- The source has inadequate supply. The Government norm for adequate supply in rural areas is 40 liters/capita/day and 30 liters/cattle/day.
- If the source contains total dissolved solids/arsenic/fluoride/iron in concentrations above their permissible limit.

According to Agarwal (2000), the number of such problem villages identified in 1972 was 150,000 and out of these, 94,000 were provided a source of drinking water by 1980, as per Government records. The number of remaining problem villages should then have become 56,000. However, a separate inventory showed that the total number of problem villages had now become 231,000 in the same year 1980. Again according to Government reports, 192,000 villages were provided a source by 1985, but 140,975 villages remained without a source. Out of these, by 1997, the problems of 110,371 villages were apparently addressed, but still the number of remaining problem villages was 61,747 instead of 30,604 which one can obtain through simple subtraction.

This bewildering and confusing statistical jugglery is a sad reflection on the failure of the methodology used till now in solving the problems, which have also increased manifold over the years. It also means that:

- The solutions found to problem villages were not sustainable.
- Some new villages which were earlier having an adequate source have turned 'problematic', possibly because of over-exploitation and
- The increasing practice of tapping deeper aquifers has led to problems of drinking water quality.

One important point to be noted is that in all the Government machinery approaches so far, the methodology adopted was to locate what was already provided for by nature if possible, at the problem village itself, or otherwise provided through expensive pipelines from elsewhere, where the natural source was available at that point in time.

There was hardly any attempt at creating a new source at the problem village itself through harvesting and conserving the precipitation endowment received annually.

The second reason was that the Government efforts failed at the operation and maintenance level. This happened because the people were not involved in the process of solving the problem. The people were neglected and in turn they neglected the upkeep of the sources made available by the Government department.

Rain water roof catchment systems (RRCS) as existing in many individual homes of the states mentioned were also surveyed and studied. Among the north-eastern states of India, Arunachal Pradesh, Nagaland, Mizoram, Manipur, Meghalaya, Assam and Sikkim, RRCS are accepted particularly in those places where the homes are scattered and the piped water supply system could not reach individual homes. In contrast, the RRCS cannot be applied in densely populated areas, where there are many industries/factories or excessive traffic load is causing to precipitate acid rains. In all the states as mentioned the average rainfall is of the order of 1500 – 3000 mm and there is no concentration of industries.

## 6.2 RAIN WATER HARVESTING

The term rainwater harvesting refers to direct collection of precipitation falling on the roof or onto the ground without passing through the stage of surface runoff on land. It is sometimes used to describe the entire gamut of water harvesting. We shall use it here only in the specific sense. There are two types of rainwater harvesting, roof water harvesting and 'In situ' water harvesting. In this chapter, roof water harvesting (RWH) methods are described.

Basically, there are two types of rainwater harvesting schemes — those designed for agricultural use and those designed for human use. Rainwater catchment schemes intended for agricultural use require large catchment areas. In this case, use of the ground surface is the obvious choice. However, water for human use should be more convenient and cleaner than water for agriculture use. Roofs are an obvious choice for a catchment surface as their elevation protects them from contamination and damage which are common to ground surface catchments.

The advantages of rainwater roof catchment system are:

- The quality of rainwater is high, if collected and stored in a hygienic manner.
- The system is independent, and therefore suitable for scattered settlements.
- Local materials and craftsmanship can be used in rainwater system construction.
- No energy costs are needed to run the system.
- Ease of maintenance by the owner/user.

The disadvantages of rainwater roof catchment system are:

- The high initial cost.
- The water available is limited by rainfall and roof area. For long dry seasons, the required storage volume may be too high, which is very expensive.
- Mineral free water has no taste while people may prefer the taste of mineral rich water.
- Mineral free water may cause nutrition deficiencies in people who are already on mineral deficient diets.

### 6.3 ROOF WATER HARVESTING (RWH)

Traditionally, rain water harvesting comprises collection of the precipitation falling onto the roof or terrace of a building and storing it in a waterproof sump at ground level for use year round or in periods of scarcity of supply from other sources such as a pond or a well. Roof water harvesting was practiced, as a matter of necessity, mostly in the low rainfall areas of the country, having annual rainfall less than 500 mm per year. Roof water harvesting and storage systems are a common features of all old buildings in North Gujarat, Saurashtra and Western Rajasthan. Roof water harvesting was also practiced in some coastal areas where the groundwater was brackish.

Modern construction during the last 50 years, especially in urban areas, has no provision for the collection and storage of roof water. The increase of population and inefficient system of distribution of municipal water supply has led to seasonal scarcity of domestic water supply in practically all the urban agglomerates. The utility of roof water harvesting is now being realized and the movement of roof water harvesting is slowly gathering momentum in urban areas. In prevailing situations of uncertain supply, having a captive source of potable water is a main resource for a dweller. The rainwater stored over the ground in a sump or recharged into a dug well or open well, provides much-needed succour during the summer months. Traditionally, the rainwater collected from roofs was always stored in sumps. In modern days, the roof water is stored in a sump and/or recharged into the local aquifer. The practice of using rainwater for directly recharging the local aquifer is becoming popular in urban areas.

Roof water harvesting has also become necessary now in hilly areas having high rainfall. The traditional perennial sources of water in such areas are springs. However, the yield of these springs has either dwindled over the years due to deforestation or the total amount supplied by them has become inadequate because of increase in population.

In some parts of Andhra Pradesh, Madhya Pradesh, Gujarat and Rajasthan, the level of fluoride in groundwater is above the permissible limit (1.5 mg/l). In parts of West Bengal and Bangladesh, the groundwater also contains arsenic above the permissible limit of 50 micrograms/liter. In these situations also, roof water harvesting is desirable although there may be no shortage of groundwater. Rainwater is practically free of dissolved solids and also does not have substances such as arsenic and fluoride.

There are areas where there is no problem with groundwater quality, or where the water table in the monsoon season does not rise up to ground level. In such areas, it is desirable and cheaper to recharge the collected precipitation into the groundwater reservoir through a percolation pit in the ground or through an existing open well or a tube well. However in areas where the groundwater quality is poor due to excess occurrence of dissolved salts/fluoride/arsenic or due to anthropogenic pollution, surface storing in sumps or other storage structures becomes a necessity. Sumps are also the only option for storing the roof harvested water in the case of a hilly terrain, having slopes or a laterite cover, as in such areas, aquifers having adequate storage capacity are generally absent.

If roof water harvesting is practiced on a large scale in an urban area, then it also helps in reducing the severity of floods, which follow a heavy downpour. Similarly if it is used for spot recharging by large number of households, then it helps in restoring the water table and also in improving the quality of water. Another benefit accruing from roof water harvesting in an urban area is that it reduces the demand on the municipal water supply system that in general is inadequate to meet the needs of each and every household.

### ***Feasibility of Roof Water Harvesting***

The initial step in planning and developing a rainwater roof catchment system involves an appraisal of the feasibility of the system. The feasibility can be determined in light of three constraints: technical, economical and social.

**Technical:** The initial consideration of the feasibility of rainwater roof catchment system concerns water availability as compared to its user demand. The total rainwater available depends on a catchment area and annual precipitation. The total annual demand is based on total design population and per capita rate of supply, which is 40 lpcd in Indian villages. If the supply exceeds demand, then rainwater roof catchment system is feasible from a technical point of view, based on total maximum supply over the period of a year. If the supply is less than demand, then possible solutions include increasing the catchment area or reducing the demand for rainwater.

**Economical:** The cost of proposed rainwater roof catchment system must be evaluated and compared with the costs of alternative water supply improvements. Costs of catchment and storage demand on which existing structures can be used, and the cost of materials. Though system may be economically justifiable, it must also be affordable to the household.

**Social:** Once it has been tentatively established that it is technically and economically feasible to construct a rainwater roof catchment system, the next step involves social and community assessment. This stage is critical to the success of the catchment scheme.

### ***Components of Rainwater Roof Catchment System***

The components of a rainwater roof catchment system include the roof, the gutter system and the storage tank (Fig. 6.1).

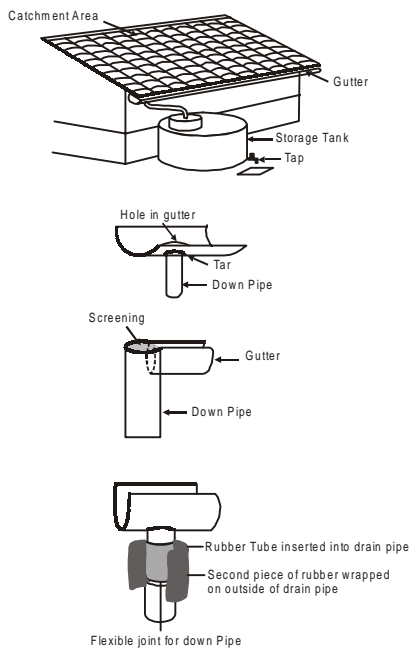

**Fig. 6.1 Components of rainwater roof catchment system.**

**The Roof Area:** To collect rainfall, the roof must be constructed of appropriate material such as corrugated metal, clay tile and locally available materials; also have sufficient surface area and be adequately sloped to allow run-off.

Corrugated metal is light in weight, easy to install and requires little maintenance. However, it may be expensive or unavailable in isolated areas where rainwater roof catchment system may be most applicable.

Clay tiles make good surfaces and are usually cheaper and longer lasting than sheet metal because they can be produced locally. However, the manufacturer of clay tiles requires a good source of clay and fuel for firing. The disadvantage of tile is their weight. A strong roof support structure is required for supporting the tiles. Roofs constructed of thatched materials such as grass and palm leaves have proved to be inexpensive and durable. The disadvantage of thatched roofs is that the run-off contains organic matter, is yellowish in colour and smells of decomposed leaves. For this reason, thatched roofs should be used in conjunction with a simple filtration device.

**The Gutter System:** Effective guttering is an important part of the rainwater roof harvesting system. Water must be efficiently conveyed from the roof to the tank to meet the homeowner's demands. A good gutter material should be lightweight, water resistant and easy to join. To reduce the number of joints and thus the likelihood of leakages, a material that is available in long, straight sections is preferred. Metal gutters are most durable and require the least maintenance. However, they are the most expensive. Regardless of the material selected, the gutter should be large enough to channel water from heavy rains without overflowing. A gutter with a cross-section of 100 sq. cm is usually

sufficient to meet this requirement. The minimum recommended depth is 7.0 cm for any gutter. The gutter should be placed at a uniform slope to prevent water from pooling or overflowing. The slope should be about 1 cm per meter. To collect the water running off during light and heavy rains, the roof should overhang the gutter by 1 or 2 cm. The gutter should extend beyond the roof edge by about 7 cm.

**The Storage Tank:** A satisfactory storage tank is the most important part of the rainwater roof water harvesting system. It is difficult to construct and must be a durable device, hence it is the most expensive component of the system. The materials used are masonry, concrete, ferro-cement, plastic, metals sheet etc. The design stage of the project involves sizing the storage tank. There are a number of methods that can be used to determine tank volume.

**Dry Season Demand versus Supply:** This approach considers the length of the dry period as a design constraint. The tank is designed so that it accommodates the household demand around during the dry season. For this reason, the method is most appropriate where there is a definite wet/dry period during the year.

The length of the dry period can be estimated by:

- Asking farmers and residents about the longest drought they remember.
- By estimating from official weather analysis data the number of consecutive dry months per year. The dry season demand versus supply method should also consider the maximum drought length in light of its probability of occurrence.

The dry season demand versus supply gives only a rough estimate of supply and demand. However, it does not take into account variations in annual rainfall patterns. A better method of tank sizing involves the Mass Curve Analysis Technique.

**Mass Curve Analysis:** A more accurate method of sizing a tank involves an analysis of data using the mass curve technique. Successful use of the technique requires approximately 10 years' data.

First, an approximation of the run-off coefficient is required. Some rainwater will be lost during collection. This amount is represented as a fraction called the run-off coefficient. This is not a precise value but is estimated on the basis of the type of roof, the condition of gutters and piping, and the evaporation expected from the roof and tank. Approximate runoff coefficient values are:

**Table 6.1 Runoff coefficients**

<i>Type of Roof</i>	<i>Good Gutters</i>	<i>Poor Gutters</i>
Metals	0.9	0.8
Other roofs	0.8	0.7

**The Filter:** Whenever it is apprehended that water may contain dust or other organic matter from the roof, simple filtration device using crushed charcoal, sand and gravel or coconut fibers or some combinations thereof as media may be installed over the storage tank.

### **Status of Rainwater Roof Catchment System in North-Eastern State**

For roofing material corrugated GI sheets have been extensively used. In few cases, thatched roof and roof made of leaves are also seen. For gutter system, the sheet metals (galvanized iron sheet) are used in many cases, though bamboo was also found in few cases. The sheet metal has the advantage as it can be sloped and jointed easily as required. The roof overhang must be 3 – 5 cm and the depth of the gutter is 7 – 15 cm. For storage purpose, the plastic tanks are very common. In very few cases, metal sheet tanks were also observed. In some cases, concrete tanks were also observed. The stone masonry tanks, which are very old, are no more in use. In some areas, where economically weaker sections of the community reside, the local government supplied storage tanks made of plastics are popularly used.

In the state Meghalaya and Manipur, small filters packed with gravels of various sizes were constructed by the state PHED and supplied free to the owners for boosting the project. They are installed in line above the storage tank. In Tripura, small filters were constructed by the state government in collaboration with UNICEF and they are also supplied free of cost in some communities. Later on, these types of filters are constructed by local NGOs.

In the surveys conducted in these states in respect of rainwater used the following figures of water use pattern by the people were observed. Actually the use of rainwater can be broadly categorized for the rainy or wet season and the dry season or no-rain period.

**Table 6.2 Use of rainwater**

<i>Purpose</i>	<i>Wet Season</i>	<i>Dry Season</i>
For drinking	30 – 35%	24 – 32%
For cooking	90 – 96%	70 – 85%
For washing clothes	75 – 90%	55 – 65%
For washing utensils	85 – 95%	60 – 68%
For bathing	40 – 58%	0
For use in latrine	34 – 48%	18 – 30%
For livestock	50 – 90%	12 – 45%
For irrigation	30 – 60%	NIL

The less use of rain water for latrine is due to the fact that many rural houses do not have latrine inside their houses and they use jungle/bushes for defecation.

For drinking water, many people carry water from public hydrants or springs, though they are located at long distances and nowhere, it was found that the people use directly rainwater collected in the storage tank. Either they boil the water or use some water filter available in the market.

Only in Tripura in few houses, there is arrangement of adding bleaching powder solution in the filter; though it is being done in a very irregular way.



### **Operation and Maintenance**

Rooftop catchment surfaces collect dust, organic matter and bird droppings, which can clog channels, cause sediment buildup on the tank bottom apart from contamination of the stored water. During periods of no rain, these materials are accumulated on the roof and they are washed off with the first rain.

The following steps are necessary for proper maintenance of various components:

**Roof:** (i) Roof must be periodically cleaned out of dust, branches of trees, leaves, bird droppings etc. (ii) Corrugated metal sheet requires to be painted preferably before each monsoon. (iii) Clay tiles are to be checked from time to time and broken tiles are to be replaced. (iv) Support structure of the roof is to be checked time to time.

**Gutter System:** (i) The gutter must be cleaned frequently to prevent overflowing during heavy rains. (ii) The joints of the gutter should be checked periodically and made correct if there is a likelihood of leakage. The joints can be sealed with tar or rubber and the jointing compound should not contaminate water. (iii) The slope of the gutter should also be checked from time to time. (iv) Metal gutters are required to be painted when required. The support of the gutter should also be checked. This can be accomplished by tying wire around the gutter and fastening it to the roof (Fig. 6.2).

**Storage Tank:** The maintenance requirements of the tank will eventually depend on the effectiveness of the first flush system and the frequency of roof and gutter cleaning. Contamination can be avoided by diverting the first 10 – 20 liters of rain from the tank. Flush traps can be used to prevent the first flush from reaching the tank. In this case, the plastic pipe over the reservoir collects the first flush water from the roof and the removable end allows discharge after each rainstorm as shown in Fig. 1, (P20 IWWA).

Another important factor is the quality of the tank cover and screening on inlet and outlet. Sunlight reaching the water will promote algae growth. Unprotected openings will also encourage mosquito breeding. So, the following steps are necessary: (i) The inside of all tanks require periodic cleaning. The water should be scrapped annually. Vinegar, baking soda or bleaching powder solutions are commonly used as cleaning agents. (ii) Sediments should be removed and walls should be scrapped annually. (iii) Care must be taken not to contaminate the next volume of incoming storage water. (iv) If cracks in the tank wall are observed, they should be replastered after each cleaning of the tank surface. (v) After cleaning and after disinfections, the water should be allowed to enter. (vi) The tank cover should be checked for tightness so that mosquito and other insects cannot find entry inside the tank. (vii) The entry pipe and the overflow pipe should be checked for proper screening arrangements to prevent entry of flies etc. (viii) Sheet metal tanks require to be painted periodically to prevent formation of rust.

**Filter:** Wherever filters are fitted over storage tank, they require frequent inspection, cleaning of the media and periodically flushing to prevent bacterial build up on the filter medium. However, in most instances the use of a filter is impractical due to the frequent maintenance required (Figs. 6.2 and 6.3).

Instead of disinfecting all the water stored in the storage tank, it is desirable to disinfect only that portion of water, which will be consumed for drinking and cooking. So covered storage vessel inside the house is required.

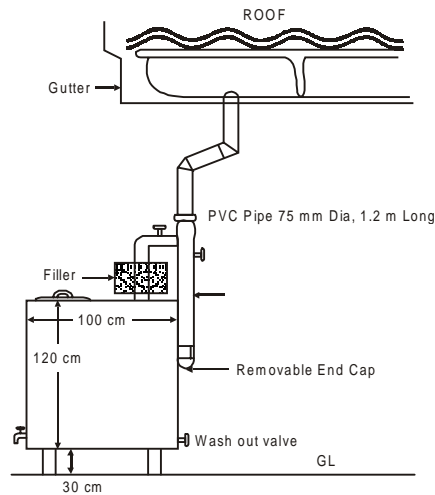

**Fig. 6.2 Storage tank with flush trap.**

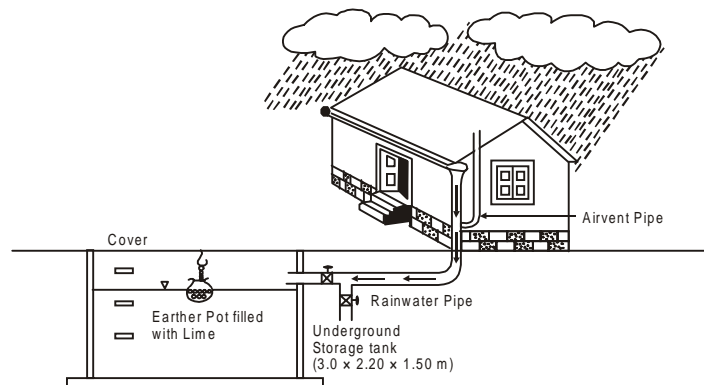

**Fig. 6.3 Schematic view of roof water harvesting system.**

### **Quantification of the Roof Harvested Water**

The amount of the water, which can be collected out of the total precipitation on a roof, depends upon the amount of rainfall, the area of the roof and the type of roof. There is no hard data generated as yet for the collection efficiency of various types of roofs. Table 6.3, which is based on educated guesswork, will give some idea about the collection efficiency.

**Table 6.3 Roof size for generating runoff of 10,000 liters in a locality having seasonal rainfall of 500 mm.**

Sr. No.	Type of Roof	Estimated Collection Efficiency (as % of Precipitation)	Roof Size in m <sup>2</sup>
1	Cement concrete	85	23.5
2	Tin sheets	75	26.7
3	Baked tiles	60	33.3
4	Thatch	40	50

Assuming an average rainfall of 500 mm and the per capita requirement of potable water for domestic use as 20 liters/person and family of five, the storage required to provide requirements for 100 days (summer season) is 10,000 liters. The roof area required for generating this amount of runoff in the case of roofs of different types is given in Table 6.3.

These calculations are for storage sump. The roof area is to be increased by about 30 % in cases where the harvested roof water is used for recharging the local aquifer. This is because only about 70 % of the recharged water can be recovered through pumping.

The roof area will proportionately increase or decrease if the local rainfall is less or more than the 500 mm value used in this model calculation. In general, the non-monsoon period rainfall amounts to 15 % to 20 % of the total annual rainfall. The rainfall value used for the calculations in Table 6.5 is for the monsoon season. Any shortfall in the average annual rainfall by 15 % to 20 % will not therefore reduce the total runoff stored in the 10,000-liter tanks. However, it is advisable, especially in the case of low rainfall areas that the roof area be kept 20-25 % larger than that calculated using the average seasonal rainfall. Such a step would compensate for the effect of low precipitation in drought years.

### **Examples of Roof Water Harvesting in Urban Areas**

Roof water harvesting is coming into vogue in urban areas. The municipal authorities of Chennai have made it a mandatory requirement of building plans submitted for approval. A few illustrative examples of roof water harvesting from individual buildings are described. An integrated approach is adopted for storing all the rainwater received by the building and the open ground of a plot of land. Some of the roof water is stored in a sump and the rest is recharged to the ground. The surface runoff from the open ground/lawn/garden within the compound wall of a building is also diverted towards a recharge facility and this water, along with rainwater is transferred underground. A sediment trap and a filter bed are used for removing the suspended particles and organic debris before the water is sent into an open well or a bore well or a percolation pit. Figure 6.4 to 6.8 shows the various methods which can be used for transferring roof water or runoff water from the plot to a dug well/bore well/pit/soak way etc. (Ranade, 2000).

**Example 1:** The Centre for Science and Environment (CSE), New Delhi, is doing a laudable work in making our society aware of our traditions of water harvesting,

and is also promoting this practice to alleviate water insufficiency. It is also engaged in demonstrating how water harvesting can be put into actual practice. The CSE building is located on a 1000m<sup>2</sup> plot. Residents are practicing both surface storage and recharge of the rain endowment received on their plot since 1999, Figs. 6.4 to 6.8.

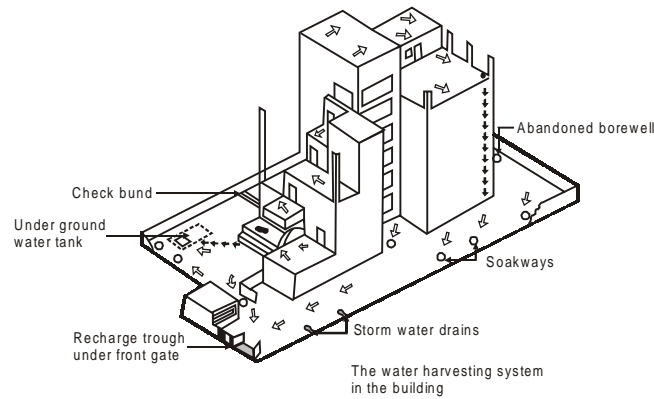

**Fig. 6.4 Schematic diagram of water harvesting system at CSE, New Delhi (Ranade, 2000)**

Fig. 6.4 Shows map of the building and compound area of the CSE, New Delhi showing various components of an integrated water harvesting system (Ranade, 2000).

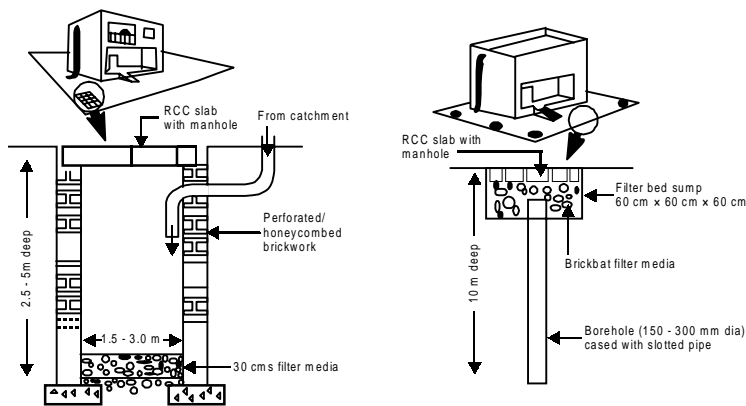

**Fig. 6.5 Schematic diagrams of a recharge pits and a soakway (Ranade, 2000).**

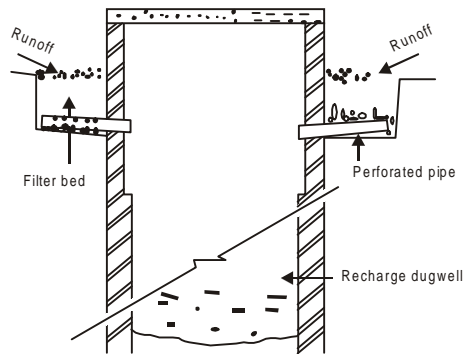

Fig. 6.6 Recharging a dug well with run-off water (Ranade, 2000).

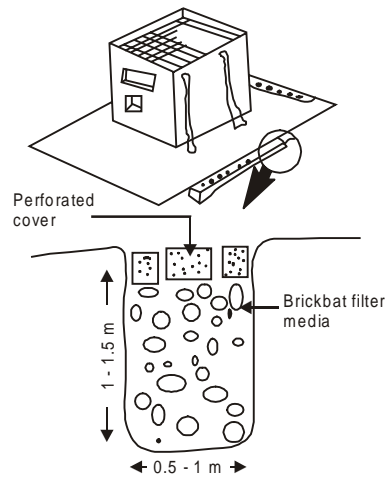

Fig. 6.7 Arrangement for percolation of water accumulated near a compound wall (Ranade, 2000).

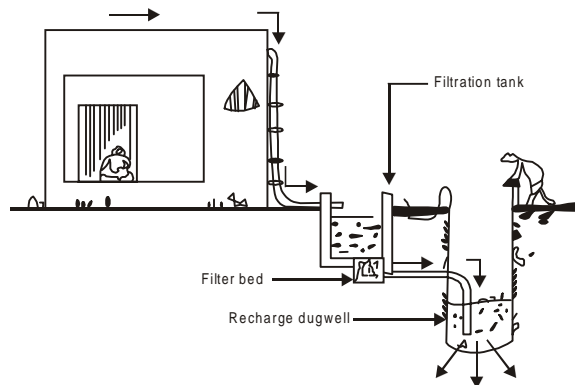

Fig. 6.8 Recharging a dug well with harvested roof water (Ranade, 2000).

The annual average rainfall in Delhi is 600 mm or 0.6 m. The total water endowment of the CSE premises is therefore 600,000 liters. They have used a combination of surface storage and various types of recharge devices such as an abandoned bore well and several soak ways. A soak way is a bore well having a diameter of about 30 cm and depth of 3 to 10m and is cased with a perforated pipe. A soak way may be filled with filter media such as brick fragments, gravel and coarse sand. A small sump is built at the top of the soak way to prevent a gush of water in the soak way (Fig. 6.5). The annually harvested water quantity is estimated as 366,000 liters or 65 % of the received rainfall. CSE claims that during the last two monsoon seasons not a single drop of rainwater drained out from their premises, even after a heavy downpour. We may therefore assume that the remaining 35% of the endowment is used in soil moisture replacement, evapotranspiration by garden plants, and natural recharge or evaporation loss. The total cost of installing the various units excluding cost of pre-existing underground water tank and pond is estimated at Rs. 36,000.

**Example 2:** Water-born bacteria and viruses are rampant during the monsoon season. Slum dwellers are particularly prone to cholera, diarrhea and other water-born diseases. Provision of clean water is very important. Tamil Nadu chapter of the National Water Harvesters Network has developed a water harvesting structure of 3000 liters capacity on a tenement building in Kuil Thotam, a slum area of Chennai, using a roof area of 1.85m × 1.85 m. Chennai has an annual average rainfall of 1200 mm and receives some rainfall every month. Some clean water can get collected in the Sintex tank (Fig. 6.9). Over 1500 liters of water was collected in the Sintex tank during the first few rain showers in actual practice. The harvested water was subjected to laboratory tests and found to be of potable standard.

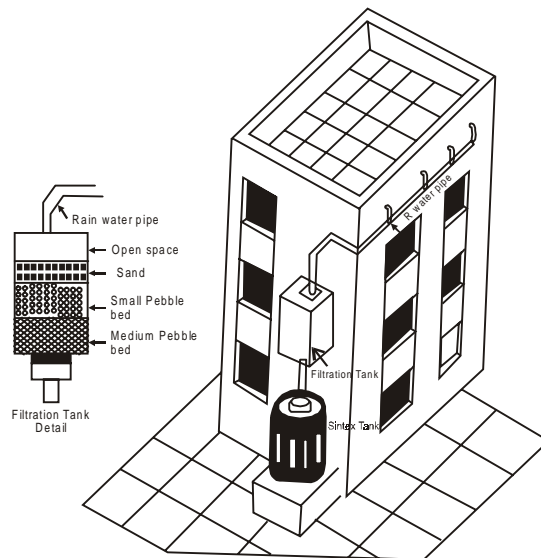

Fig. 6.9 Roof water harvesting system at a slum tenement in Kuil Thotam, Chennai (Khurana, 1999).

A commonly raised quarry by those intending to install facilities for recharging the harvested water is about the rate at which the runoff from roof or ground level will be accepted by the local aquifers. This is a difficult question to answer generally. The hydraulic conductivity ( $k$ ) of soils or aquifer material is a key parameter, which varies very widely. For example, clean gravel has  $k$  values ranging between 1 and 100 cm/sec while the  $k$  value for sandy loam ranges between 0.003 to 0.005 cm/sec and that of clay can be less than 0.00001 cm/sec. Soils are mixture of gravel, sand, silt and clay whose proportions in the soil vary from place to place. The best way to know the infiltration rate is by a trial experiment. It is also advisable to provide buffer storage Ranade type figure (Fig. 6.5). This will ensure that the runoff after a heavy storm does not overflow the recharge pit.

### ***Examples of Mass Scale Urban Harvesting***

Case of Aizawl, Capital of Mizoram, N E, India: The public water supply system of Aizawl, capital of Mizoram state in N E, India, comprise lifting water from the Tlawng River. It is capable of supplying water to 80,000 people at the rate of 135 lpcd. However, this is quite inadequate to meet the needs of the present population, which has doubled. Some of the newer localities are not even connected to piped water supply system. The houses in Aizawl traditionally have sloping galvanized iron sheets as roofs. These are used for rainwater harvesting. About 10,000 houses have constructed such structures to alleviate the uncertainty of year round supply. The annual average rainfall at Aizawl is 2500 mm. A 50m<sup>2</sup> roof area can easily produce enough runoff to store 10,000 liters which can be used during the summer season (120 days) by a family of 8 persons at the rate of 10 lpcd. The storage tanks are made of RCC, ferrocement or plastic (Dunglana, 2001).

Case of National Capital Territory (NCT) of Delhi: If roof water harvesting of the type mentioned above can be undertaken on a large scale in an urban metropolis, then it can make a substantial improvement in the status of year round availability of potable water. The present water requirement of Delhi is about 3324 million liters/day while installed capacity is about 2634 mld (Ranade, 2000). The supply is approximately 80 % of the demand with a shortfall of about 790 mld.

Sharma and Sharma (2000) have carried out a multi-spectral analysis of satellite data to estimate the roof area available for rainwater harvesting in Delhi city, Delhi state and the National Capital Territory region. These authors estimate 66.5 sq. km as the rooftop area of Delhi amenable to harvesting. This works out to around to around 35 % of the city area. The total of rainwater that can be harvested from this roof area is estimated as 39 mcm, 80 % of which can be recharged to groundwater. The additional quantity thus made available through roof water harvesting is about 88 mld, which is 11 % of the daily requirement.

## **6.4 WATER HARVESTING BY PONDS**

The traditional practice of collecting rainwater in village ponds suffers from following limitations:

1. Large open surface is subjected to high rate of evaporation losses.
2. Large bed area effecting high seepage losses.

In spite of limitations, the village ponds, the bulk water requirement for half the year is met from them. Small groundwater mound formed under the pond bed, used to partially supply through wells dug in the pond bed. This traditionally practiced rainwater-harvesting structure served water supply since ages. During scarcity years, some deepening of ponds is made, but it is being done on a haphazard manner, does not help much.

### **Pond Lining**

The limitations of the traditional ponds, especially the quality deterioration and seepage losses could be completely stopped by using plastic membrane. The simple technique has proved effective. The evaporation loss could be checked by use of chemical retardants and adopting system of multiple ponds system (compartments). Limitation of the depth factor has to be accepted and required storage could be built by increasing the length and breadth of the pond. Of course, the places where salty water table is at greater depth, pond storage can be increased even with less open surface, and thereby reducing the evaporation loss. Such favorable locations may not be provided with plastic lining, provided the rate of salt contamination from sediments is within limits. Plastic lining is a rather costly proposition, however, it envisages the use of local water resources and regular maintenance is almost negligible.

This technology involves lining of the walls and floor of the pond, tank reservoir with tough, wide-width low-density polyethylene (LDPE) film. These LDPE films are available in widths of 4 to 12 m and thickness 100 to 250 microns. These films meet specifications as per IS: 2508 – 1984. This film has excellent water barrier properties, very good blend of physical properties such as tensile impact strength coupled with good weatherability and chemical resistance properties. These films also prevent the inherent salinity of the soils and saline groundwater from seeping into pond or tank and starts contamination. The construction of plastic lined pond includes excavation work, screening work for removing big boulders and sharp-edged gravel, which could damage the plastic film, dressing of sides and beds so that lining is not punctured, laying plastic film on beds and sides, brick lining on the sidewalls, soil filling on the floor, inlet system and distribution system. At present, 19 villages of Bhal area of Gujarat have 20 such plastic lined ponds (Fig. 6.10).

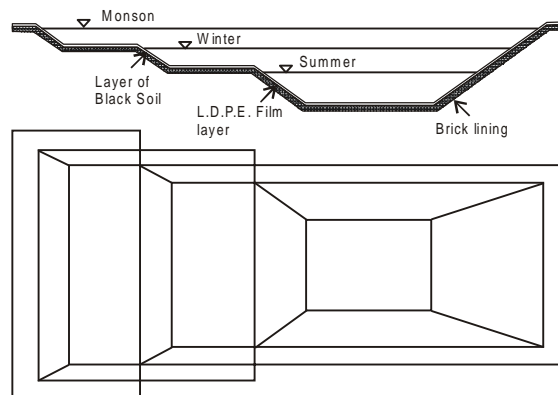

**Fig. 6.10** Water harvesting by means of brick and plastic lined ponds.



## 6.5 WATER QUALITY CONSIDERATION

Although, the stored rainwater will not always meet WHO standards, it frequently does so, and generally speaking it is of far higher quality than most of the traditional sources and many of the improved water sources found in the developing countries (Gould, 1991).

Roof catchment system can provide good quality of rainwater; clean enough for any one to drink, so long as the points discussed are incorporated. Roofs should be very clean that will not add pollutants to the water. These should also be free from overhanging trees since these provide sanctuary for birds and animals, which could defecate on the roof and thus contaminate the rainwater. The cistern should be securely covered to prevent the entry of dirt, animals and light, all of which contribute to biological contamination (Latham & Gould, 1986). Provision should be made for cleaning the cistern on a regular basis. Implementation of a filtration unit at the entrance of the cistern may help to improve the quality of water.

A study of cisterns rainwater quality carried out in the West Bank, examined its chemical and biological contamination. Samples from 500 cisterns were collected, tested and analyzed three times during the study.

The chemical analyses included the determination of the concentration of major cations (calcium, magnesium, sodium, potassium) and anions (chloride, carbonate, bicarbonate). The analyses also included measurement of pH, electric conductance, total dissolved solids, and total hardness. The results of chemical analyses are presented in Table 6.4. The analyses revealed that none of chemical constituents exceeded WHO standards with the exception of some high and low values of some parameters. This means that, chemically, the cisterns water is of high quality and very suitable for drinking and domestic purposes.

**Table 6.4 Results of the chemical analysis of cistern water samples**

Constituents	WHO standards (mg/l)	Concentration Observed in (mg/l)		
		Minimum	Maximum	Average of 500
pH	6.5 – 9.2	7.50	9.00	8.10
EC ( $\mu$ mho/cm)	<250	0.17	1.20	0.45
TDS	200 – 500	80.00	560.00	237.50
TH	200 – 500	70.00	423.00	182.60
Calcium	75 – 200	18.10	94.60	45.10
Magnesium	50 – 150	1.00	92.00	20.80
Sodium	100 – 200	5.00	41.00	11.00
Potassium	0 – 10	1.00	12.00	3.30
Chloride	200 – 600	18.00	138.00	41.70
Carbonate	0 – 50	1.20	67.20	21.10
Bicarbonate	0 – 500	41.60	315.50	146.90

The study of biological contamination was limited to the investigation of the presence of total coliforms. Samples from 500 rainwater cisterns were tested. 135 out of 500 samples contained coliforms and 365 samples contained zero coliforms. The total coliform colony counts revealed through sample testing are presented in Table 6.5. It reveals that 27% of the cisterns water in the West Bank is contaminated by coliforms and did not meet WHO drinking water standards, while 73% is not contaminated and meets WHO drinking water standards. Despite this finding, it may still be concluded that cisterns water in general is safe and of good quality for drinking and domestic uses.

**Table 6.5 Total coliform counts in 100 ml samples of cistern water in the West Bank**

<i>Total coliform counts in 100 ml samples</i>	<i>Total number of samples</i>	<i>% Total number of samples</i>
0	365	73.0
1 – 10	25	5.0
11 – 20	38	7.6
21 – 30	30	6.0
31 – 40	17	3.4
41 – 50	10	2.0
>50	15	3.0
Total	500	100.0

Operation and maintenance of rainwater roof catchment system is the family's responsibility and this is the most advantageous side of the rainwater roof catchment system. In the beginning, there may be little difficulties and after sometimes they gain experience especially in the use of water; lessons learned during the first year's dry season about correct water use would likely be used in subsequent years. If the tank runs dry during the dry season, it is possible that water is being used for purpose other than what it was intended for. The user must be aware of the dangers of using too much water too early in the dry season. It is the project's responsibility to ensure the householder is fully aware of the uses of rainwater before the first dry season arrives. Water shortage during the dry season, can be avoided by making sure the tank is full at the end of the wet season and the calculated minimum demand remains constant throughout the year. It is recommended that water collected from a thatched or leaky roof be used for livestock consumption, irrigation use or for flushing toilets. It will be a good idea to set up a programme of inspection and repair of systems. This should include education for the user and training of local technicians to carry out repairs. Local authorities should encourage maintenance and organize inspection from a central agency.

The project developer must determine the extent of community needs. This must be done in the light of traditional practices within the community. The role of women and the children in carrying water and the amount of time spent in this activity should be examined. Particularly,

the women can help in mobilizing support for the rainwater collection system raising the initial capital. Women and children also can contribute most of the labour. The engineer should collect information on existing catchment technologies and discuss the community the usefulness of water supplied by a roof system. The community's need for communal versus individual catchment system should be evaluated.

The project engineer must also compile a resources inventory of local skills, materials and experience that can be used in rainwater roof catchment system. Materials, which are easy to obtain by local people who know how to work with the materials, will result in a rooftop system that is cheap and simple to build and repair. To make the system widespread, some sort of financial help is to be given to the villagers. This can be in the form of subsidy or low interest loan. The Government or local societies can come forward for this so that the whole burden is not put on the beneficiary itself.

Rainwater collection system, though implemented in many parts of north – eastern states, is not gaining popularity because the owners do not properly maintain the system. The water collected in this system is not of standard quality and mainly used for other purposes except drinking and cooking.

# 7 ARTIFICIAL RECHARGE METHODS

## 7.1 INTRODUCTION

The term Artificial Recharge refers to transfer of surface water to sub-surface aquifers through human intervention. Augmentation of groundwater resources through artificial recharge can be considered as an activity, which supplements the natural process of recharging the aquifers through percolation of a fraction of the rainfall through the soil to the water table. Artificial recharge thus becomes relevant in a situation witnessed by India, where the rainfall is seasonal and is not spread uniformly over the year and quantum of natural recharge is inadequate to meet the increasing demand on groundwater resources.

## 7.2 NATURAL RECHARGE MEASUREMENTS IN INDIA

Natural recharge measurements carried out in about 20 basins, well distributed over the various climatic and geomorphic zone obtaining in the country, suggest that about 5 to 10 percent of the seasonal rainfall is contributed as annual recharge in the peninsular hard rock regions, whereas in the alluvial areas, about 15 to 20 percent of the rainfall is contributed to groundwater (Athavale, 1992). The natural recharge process is seasonal nature, but the exploitation of groundwater is continuous and is increasing every year. Groundwater exploitation in India has increased with leaps and bounds and the number of shallow wells has increased rapidly over the past 40 years. The growth of groundwater abstraction structures from 1950 to 1990 clearly depicts the increasing use of groundwater utilization in agricultural sector.

As a result, many areas in the country are showing signs of over-exploitation. In several areas, the withdrawal of groundwater is in excess of the annual input through natural recharge and this is manifested through lowering of water table, drying of wells and deterioration in quality. The effects of overexploitation become more apparent in hard rock covered drought prone areas. In several thousand villages and some urban locations, the drinking water demand in summer is met through water tankers.

Artificial recharge can be used in such situations to augment the groundwater reserves by transferring the surface water to the aquifers during the monsoon months and using this water in summer months. At present, a large percentage of the precipitation is lost to sea through runoff or is lost through evaporation from surface storage structures. Artificial recharge can also

be used for improving the quality of groundwater in areas where it is brackish or contains toxic chemicals such as fluoride and arsenic, in concentrations above their permissible limits.

### 7.3 CONCEPT OF ARTIFICIAL RECHARGE

Artificial recharge projects are designed to serve one or more of the following purposes.

1. Maintain or augment the natural groundwater as an economic resource.
2. Co-ordinate operation of surface and groundwater reservoirs.
3. Combat adverse conditions such as progressive lowering of groundwater levels, unfavorable salt balance and salt-water intrusion.
4. Provide subsurface storage for local or imported surface water.
5. Reduce or stop significant land subsidence.
6. Provide a localized sub-surface distribution system for established wells.
7. Provide treatment and storage for reclaimed wastewater for subsequent reuse.
8. Conserve or extract energy in the form of hot or cold water.

### 7.4 METHODS OF ARTIFICIAL RECHARGE

Artificial recharge may be defined as the planned activity of man whereby surface water from streams and lakes is made to infiltrate to the ground, commonly at rates and in quantities many times in excess of natural recharge. Increasing water demands require more storage of water in times of water surplus for use in times of water need. Traditionally, this has been achieved through dams. However, dams have finite life because of eventual structural failure and sediment accumulation in the reservoir. Also, good dam sites are becoming increasingly scarce, not possible in flat areas; they lose water by evaporation and can also have adverse environmental and socioeconomic impact. If water cannot be stored above the ground, it must be stored below the ground, via enhanced or artificial recharge of groundwater.

#### **Recharge**

Artificial recharge of groundwater can be achieved with surface infiltration system (basins, spreading facilities), wells trenches, pits, shafts etc. Surface infiltration systems require the availability of adequate land with permeable soils, vadose zones without restricting layers that produce excessive perched mounds and unconfined aquifers of sufficient transmissivity to prevent undue occurrence of groundwater mounds. Also, Vamoose zones and aquifers should be free from undesirable chemicals (contaminated areas, pollution plumes) that can move with the recharge flow system to where they are not wanted.

Where suitable conditions for surface infiltration systems do not exist or aquifers are confined, recharge can be accomplished with wells, pits or shafts. Water source for recharge include any excess surface water from streams, irrigation canals, aqueducts and storm water runoff.

For unpolluted water, the only pretreatment that may be necessary before infiltration is sediment removal, as it can be accomplished with pre-sedimentation basins (with or without use of coagulants) or vegetative filtration in overland flow type systems.

### ***Sustainability***

Recharge systems using clean water should be completely sustainable. Clogging of the surface where infiltration takes place will occur because of biological activity and/or accumulation of suspended solids. For surface infiltration systems such clogging can readily be remedied by periodic drying and cleaning of the infiltration system (removing the clogging layer by shaving or scraping the surface). For well recharge, remedy of clogging is more difficult and adequate pretreatment of the water is necessary to prevent clogging as much as possible. Frequent pumping of the recharge well (5 minutes each day, for example) to reverse the flow may prevent or delay clogging. Periodic redevelopment of the well by surging, jetting or other techniques may keep well clogging under control.

### ***Considerations***

The type of the artificial recharge system that can be developed at any specific site is controlled, to a large degree, by the geologic and hydrologic conditions that exist at that site.

Site selection criteria, in addition to economic considerations, should include at least the following:

- (1) Source of recharge water
- (2) Chemical and physical characteristics of the recharge water
- (3) Availability of an aquifer suitable for artificial recharge
- (4) Thickness and permeability of the material overlying the aquifer, if any
- (5) Thickness and permeability of the aquifer
- (6) Chemical characteristics of water in the aquifer
- (7) Proximity of the potential recharge site to an appropriate well field cone of depression
- (8) Water level differences between the aquifer and the recharge site
- (9) Topography

Mainly there are three main categories of artificial recharge as listed below.

- (A) Direct methods.
- (B) Indirect methods.
- (C) Incidental methods.

**(A) Direct Methods:** Direct methods of recharge can further be subdivided into two main categories as surface methods and sub-surface methods.

**A – I: Surface Methods:** In this method of recharge, water is applied on the permeable ground surface where it infiltrates into the unsaturated zone to reach slowly the undergroundwater table. Surface techniques, especially spreading techniques of artificial recharge are most widely used because of their economy and easiness in operation. Various types of spreading techniques are as follows:

- Basins
- Furrows and ditches

- Regulated stream channels
- Flooding

**Basin Method:** Excavation or building dikes or levees constitute basins (Fig 7.1). The shape and size of the basin depends upon topography and availability of land. To reduce deposition of sediments, the water released to the basin should have minimum sediment. This can be achieved by:

- The water may be diverted to the basin during the non-flood periods, when the suspended sediment is low;
- By adding certain chemicals in the water to remove sediments;
- Sedimentation of basins is provided to hold water before releasing it into the recharge basin.

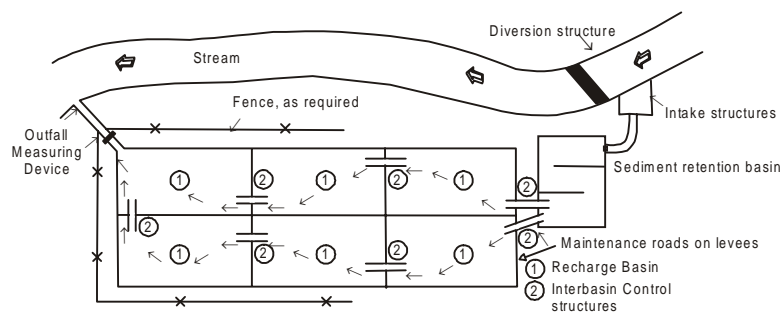

**Fig. 7.1 Layout of recharge basins.**

### **Requirements of Recharge Basin Sites**

- To have a knowledge of surface geology downward in the basin and laterally away from the basin;
- To have a considerable knowledge of permeable soil in the basin which permits adequate infiltration rate;
- To have a sufficient knowledge of the unsaturated zone between ground surface and water table.

### **Furrows and Ditches Method**

This method of recharge is useful for irregular terrain. Furrows and ditches should be shallow, flat bottomed, and closely spread to obtain maximum water contact area. Gradient of major ditches should be sufficient to carry suspended material through the system so that surface openings are not clogged due to deposition of fine-grained material. The design of furrows and ditches system depends upon the topography and size of area. A collecting ditch is necessary at the lower end of the area to return excess water to the main channel. (Fig. 7.2 and Fig. 7.3).

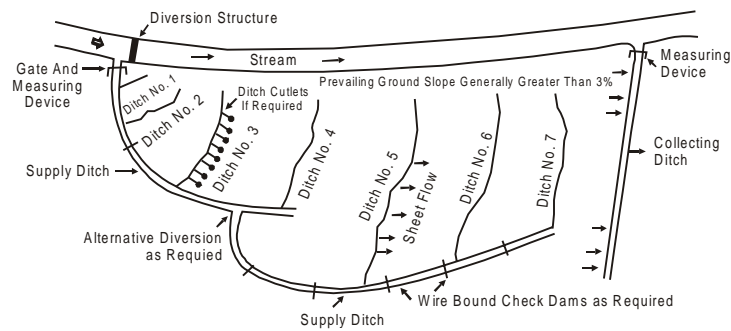

**Fig. 7.2 Furrows and ditches method.**

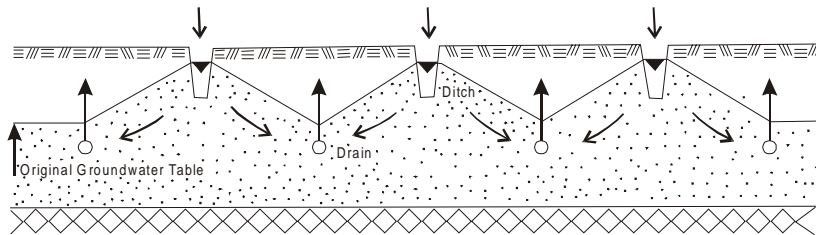

**Fig. 7.3 Artificial recharge using ditches and drains.**

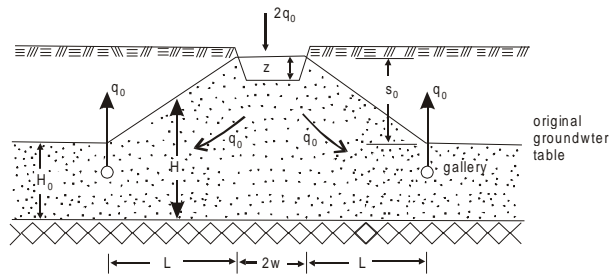

**Fig. 7.4 Artificial recharge with parallel ditches and drains.**

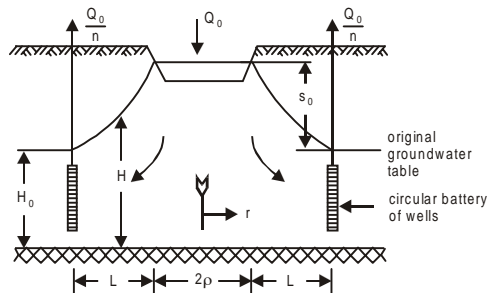

**Fig. 7.5 Artificial recharge with a spreading pond surrounded by a concentric battery of wells.**



**Stream Channel Method:** (Figs. 7. 6 & 7.7)

The object of this method is to extend the time and area over which water is recharged from a natural influent channel. It requires upstream storage facilities to regulate stream flows and to enhance infiltration. The flow rate of the water should be such that it should not exceed the absorptive capacity of downstream channels. Different types of stream channel include:

- Widening, leveling or scarifying a bed of channel,
- Permanent low check dams,
- Temporary low check dams of stream bed materials,
- L – shaped finger levees.

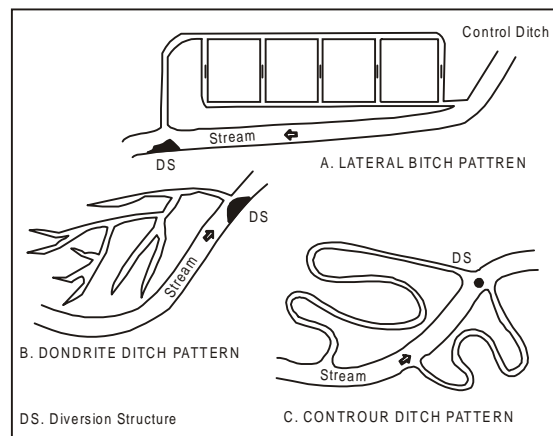

**Fig. 7.6 Patterns of furrows and ditches system.**

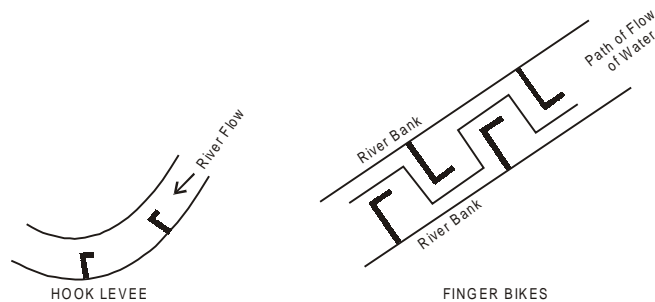

**Fig. 7.7 Stream channel modification method.**

## 7.5 THEORY OF ARTIFICIAL RECHARGE BY SPREADING

As a variant of induced recharge, the most likely set-up of an artificial recharge scheme consists of a series of spreading ditches and infiltration galleries arranged alternately at equal intervals, as shown in Fig. 7.3. For unconfined aquifers pervious up to the ground surface, this set-up

offers few difficulties. With slight modifications, it may also be applied for artesian aquifers when the confining layer on top is thin. For confined aquifers covered by thick deposits of less pervious material, recharge must be accomplished by injection wells, having their own problem and possibilities. The simplest construction of parallel spreading ditches and infiltration galleries is shown in Fig. 7.4, where the coefficient of transmissivity,  $kH$ , of the aquifer as well as the maximum allowable drawdown,  $S_0$ , are determined by the local geo-hydrological conditions. The other factors indicated in this figure,  $q_0$ ,  $L$  and  $w$ , must be chosen such that the purposes of the recharge scheme are fulfilled, that is to say, an adequate detention time of the recharge water in the sub-soil and no rapid clogging of the spreading basins. When it is provisionally assumed that both the spreading basin and the gallery for groundwater recovery fully penetrate the saturated thickness of the aquifer, these requirements may be formulated mathematically as

- (a) detention time  
 $T = pH L / q_0$  or  $q_0 = pH L / T$
- (b) drawdown  
 $S_0 = [q_0 / (kH)] L$  or  $q_0 < kH S_0$
- (c) entry rate  
 $v_e = q_0 / w$  or  $q_0 < v_e w$

The last requirement can always be satisfied by increasing the width of the spreading basin, while the first two requirements give as length and flow rate

$$L = \sqrt{k S_0 T / p} \quad q_0 = (H / T) \sqrt{k S_0 p T} = H \sqrt{k S_0 p / T}$$

With shallow aquifers composed of fine sand,  $H$  and  $k$  will be small, calling for a short length and a low flow rate, which can best be accomplished with the scheme of Fig. 7.3. With deep aquifers built up of coarse sand and high values of  $H$  and  $k$ , the length and, in particular, the flow rate may be much greater. The scheme of Fig. 7.3 may again be used, but in plan it tends to be rather square, leading more or less automatically to the recharge scheme of Fig. 7.5, here consisting of a spreading pond surrounded by a circular battery of wells for recovery of groundwater.

**Spreading in shallow phreatic aquifer:** The design procedures to be used in this case can best be demonstrated with an example (Huisman, 1985). Consider an aquifer composed of fine sand with a coefficient of permeability  $k = 0.12 \times 10^{-3}$  m/s, a porosity  $p = 0.38$ , a saturated thickness,  $H_0$ , before spreading of 15 m, a maximum allowable rise of water table equal to  $S_0 = 2$  m, giving together an average saturated thickness during spreading of  $H = 16$  m. A capacity  $Q_0 = 30 \times 10^6$  m<sup>3</sup>/year or 0.951 m<sup>3</sup>/s is sought, with a detention time  $T = 8$  weeks or  $4.84 \times 10^6$  s and a maximum allowable entry rate  $v_e = 0.4$  m/day or  $4.63 \times 10^{-6}$  m/s. This gives as length and flow rate (Fig. 7.4).

$$L = \sqrt{\frac{0.12 \times 10^{-3} \times 2 \times 4.84 \times 10^6}{0.38}} = 55.3 \text{ m}$$

$$q_0 = 16 \sqrt{\frac{0.12 \times 10^{-3} \times 2 \times 0.38}{4.84 \times 10^6}} = 69.5 \times 10^{-6} \text{ m}^3 \text{ m}^{-1} \text{ s}^{-1}$$

The width of the spreading basin thus equals

$$2w = \frac{2 \times 69.5 \times 10^{-6}}{4.63 \times 10^{-6}} = 30.0 \text{ m}$$

and the combined length of the spreading basins

$$B = \frac{0.951}{2 \times 69.5 \times 10^{-6}} = 6840 \text{ m}$$

the total area between the infiltration galleries equals

$$A = 6840 \times [30.0 + (2 \times 55.3)] = 0.962 \times 10^6 \text{ m}^2$$

This area could also have been calculated directly:

$$A = \frac{Q_0 T}{\rho H} + \frac{Q_0 T}{v_e} = (0.757 \times 10^6) + (0.205 \times 10^6) = 0.962 \times 10^6 \text{ m}^2$$

The amount of water in dynamic storage, that is, in the pores of the formation between the original and the present water table is

$V = \mu S_0 (L + 2w) B$ , of which a fraction,  $\mu/p$ , can be used. With, for instance,  $\mu = 0.25$  and the other factors as assumed before,

$V = 0.25 \times 2 \times (55.3 + 30.0) \times 6840 = 0.292 \times 10^6 \text{ m}^3$ , allowing an interruption in the spreading operations for a period,  $t = V/Q_0 = (0.292 \times 10^6)/0.951 = 0.307 \times 10^6 \text{ s}$  or 3.6 days.

This period will seldom be adequate to let a wave of polluted river water pass the point of intake. The calculations given above have the attraction of being simple and straight forward, but they have strongly simplified reality, demanding at this point a number of corrections. The first simplification is the assumption of a constant saturated thickness,  $H$ , in the calculation of the drawdown,  $S_0$

$$S_0 = [q_0/(kH)]L = 2.0 \text{ m}$$

Taking into account the variations in water table elevation as well as the recharge by available

rainfall,  $P$  (say 400 mm/year or  $12.7 \times 10^9 \text{ m/s}$ ), with the notation of Fig. 3a, the following as a correct calculation

$$(H_0 + S_0')^2 - H_0^2 = \frac{2q_0 L}{k} - \frac{PL^2}{k}$$

and for the case under consideration  $S_0' = 2.01 \text{ m}$ , a negligible difference compared with the value of 2.0 m originally assumed.

The second simplified concerns the assumption that the spreading ditch fully penetrates the saturated thickness of the aquifer and does so over a width  $2w$ . To correct this, the spreading ditch is first replaced by a fully penetrating one of zero width, increasing the flow length by an amount  $w$  and giving an additional drawdown

$$\Delta S_1 = \frac{q_0}{k(H_0 + S_0)} w = 0.51 \text{ m}$$

Replacing this ditch by the real one gives, the additional drawdown as

$$\Delta S_2 = \frac{2q_0}{\pi k} \ln \left( \frac{H_0 + S_0}{2w} \right) = -0.21 \text{ m}$$

together

$$\sum S_0 = 2.01 + 0.51 - 0.21 = 2.31 \text{ m}$$

The third simplification involves the finite length of the spreading ditch. When the area available has a more or less square plan, the total length of the spreading ditches, calculated at 6849m, must be broken up into 6 units, each of a length  $B = 1140$  m. This gives a ratio of  $B$  over  $L$  equal to  $1140/55.3 \simeq 20$  and, a weighted average reduction in drawdown by a factor of

$$\frac{1}{6} (2\alpha_2 + 4\alpha_3) = 1.04, \text{ thus } \sum S_0 = 2.31/1.04 = 2.22 \text{ m}$$

When the increase in drawdown from 2.0 to 2.14 m is not acceptable, the foregoing calculations must be made a new, starting from a value of  $S_0$  equal to 1.85 m, as indicated in Fig. 3a. The piezometric level inside the gallery is less than that which corresponds with  $H_0 = 15$  m, but this does not affect the groundwater tables outside the recharge area. With a number of spreading ditches parallel to one another, the capacity of the gallery equals  $2 \times 69.5 \times 10^{-6} = 139 \times 10^{-6} \text{ m}^3 \text{ m}^{-1} \text{ s}^{-1}$ , giving for a circular drain of 0.5 m outside diameter the additional drawdown due to partial penetration as

$$\Delta S = \frac{q_0}{\pi k} \ln \left( \frac{H}{\Omega} \right) = \frac{139 \times 10^{-6}}{\pi(0.12 \times 10^{-3})} \ln \left( \frac{15}{\pi \times 0.5} \right) = 0.83 \text{ m}$$

to which must be added the entrance resistance caused by clogging. Finally, it should be noted that, at the outset of the calculations, a spreading ditch fully penetrating the saturated thickness of the aquifer over a width  $2w$  has been assumed. Replacing this ditch by the real one slightly lowers the minimum detention time, but with regard to the improvement in water quality during underground flow, this decrease is more than compensated by an increase in average detention time, roughly by a factor  $(L+w)/L$  to  $6.2 \times 10^6$ s or 10 weeks.

**Spreading in deep phreatic aquifer:** The difference in spreading operations for deep and shallow aquifers is not a principal one, but only concerns the layout of the spreading area. Again, this can best be clarified with an example, assuming in this case that  $Q_0 = 30 \times 10^6 \text{ m}^3/\text{year} = 0.951 \text{ m}^3/\text{s}$ ,  $k = 0.4 \times 10^{-3} \text{ m/s}$ ,  $p = 0.38$ ,  $\mu = 0.32$ ,  $v_c = 5 \text{ cm/h} = 13.9 \times 10^{-6} \text{ m/s}$ ,

$H_0 = 60$  m,  $S_0 = 5$  m,  $H = 62.5$  m,  $T = 8$  months  $= 21.0 \times 10^6$  s, to allow when desired a linear spread in detention times, varying between 2 and 14 months. This gives, in the same way as described in the preceding section,

$$L = \sqrt{kS_0 T/P} = 332.5 \text{ m}$$

$$q_0 = H \sqrt{kS_0 P/T} = 376.0 \times 10^{-6} \text{ m}^3 \text{ m}^{-1} \text{ s}^{-1}$$

$$w = q_0/v_e = 27.0 \text{ m}; B = Q_0/2q_0 = 1265 \text{ m}$$

$$A = 2B(L + w) = 0.910 \times 10^6 \text{ m}^2$$

$$V = \mu S_0(L + 2w)B = 0.782 \times 10^6 \text{ m}^2$$

allowing an interruption in spreading of 9.5 days. The corrected draw down follows from ( $P = 12.7 \times 10^{-9}$  m/s).

$$(H_0 + S'_0)^2 - (H_0)^2 = \frac{2q_0 L}{k} - \frac{PL^2}{k} \text{ or } S'_0 = 4.97 \text{ m}$$

$$\Delta S_1 = \frac{q_0}{k(H_0 + S_0)} w = 0.39 \text{ m}$$

$$\Delta S_2 = \frac{2q_0}{\pi k} \ln \left( \frac{H_0 + S_0}{2w} \right) = 0.11 \text{ m}$$

$$\Sigma S_0 = 5.03 + 0.39 + 0.11 = 5.53 \text{ m}$$

For a single spreading ditch, bounded at both sides by parallel infiltration galleries with reduction factors for additional flows around the far ends, reducing  $\Sigma S_0$  to 4.69 m, or well below the maximum allowable value of 5 m.

In the case considered above, the recharge area has a width of 719 m and a length of 1256 m, thus approaching a square plan. This points to the possibility of a circular battery of wells, as shown in Fig 3b. With the notation of this figure, the design criteria become

(a) *Detention time*, neglecting the soil mass below the spreading pond:

$$T = pH\pi [(\rho + L)^2 - \rho^2]/Q_0$$

(b) *Drawdown*, composed of two terms:  $S_0 = S_1 + S_2$ , with  $S_1$  as the flow resistance from the rim of the spreading pond to the concentric battery of wells, calculated from

$$(H_0 + S_1)^2 - H_0^2 = \frac{Q_0}{\pi k} \ln \left( \frac{\rho + L}{L} \right); \text{ and } S_2 \text{ as flow resistance below the spreading pond,}$$

calculated from  $S_2 = \frac{Q_0}{2\pi kH} \alpha$ , with  $\alpha$  tabulated as follows

$2\rho/H$	0.01	0.1	1	10	100
$\alpha$	308	27.6	1.58	0.088	0.0088

With sufficient accuracy,  $\alpha$  may be calculated from

$$\alpha = \exp(0.415 - 1.29x + 0.004x^2 + 0.0073x^3) \text{ with } x = \ln(2\rho/H)$$

(c) *Entry rate*

$$v_e = Q_0 / (\pi\rho^2)$$

With the same data as used in the example above, this gives

$$(c) \quad \rho = 147.6 \text{ m}$$

$$(a) \quad L = 390.4 \text{ m}$$

$$(b) \quad S_1 = 7.67 \text{ m}$$

$$S_2 = 1.28 \text{ m}$$

$$S_0 = 8.95 \text{ m}$$

The value for  $S_0$  is much larger than the maximum allowable value of 5.0 m. To remedy this situation, the value of  $\rho$  is increased to 285 m, producing

$$(a) \quad L = 306 \text{ m}$$

$$(b) \quad S_1 = 4.44 \text{ m}$$

$$S_2 = 0.58 \text{ m}$$

$$S_0 = 5.02 \text{ m}$$

This value for  $S_0$  is close enough to the maximum allowable value of 5.0 m to be acceptable. With regard to the entry rate, a full pond of 285 m radius is not necessary and may be replaced by a circular ditch with an outer radius of, again, 285 m and a width of 41.2 m only.

The total area occupied by this circular scheme equals  $\pi(285 + 306)^2 = 1.097 \times 10^6 \text{ m}^2$  or 21% more than with the rectangular one. The amount of water in dynamic storage now equals

$$V = \mu S_0 \pi \rho^2 \int_{\rho}^{\rho+L} \mu S_2 \pi r dr$$

$$\text{with, approximately, } S = S_0 \frac{\ln[(L + \rho)/r]}{\ln[(L + \rho)/\rho]}$$

This gives

$$V = \mu S_0 \pi \frac{(L + \rho)^2 - \rho^2}{2 \ln[(L + \rho)/\rho]}$$

and in the case under consideration  $V = 0.927 \times 10^6 \text{ m}^3$ , allowing an interruption in operating operations of no less than 11.3 days.

As regards the pumping equipment of the wells for groundwater recovery, the additional drawdowns of point abstraction and partial penetration should be taken into account. With

say, 40 wells, the individual capacity equals  $23.8 \times 10^{-3} \text{ m}^3/\text{s}$  and the intervals between wells 99 m. With a screen length of 20 m ( $p = 20/60 = 0.333$ ) and an outside diameter of the gravel pack of  $2r_0 = 0.60 \text{ m}$ , this gives

$$\Delta S_{pa} = \frac{23.8 \times 10^{-3}}{2\pi \times 0.4 \times 10^{-3} \times 60} \ln\left(\frac{99}{2\pi \times 0.3}\right) = 0.63 \text{ m}$$

$$\Delta S_{pp} = \frac{23.8 \times 10^{-3}}{2\pi \times 0.4 \times 10^{-3} \times 60} \frac{1-0.333}{0.333} \ln\left[\frac{(1-0.333) \times 20}{0.30}\right] = 1.20 \text{ m}$$

to which must still be added the additional resistance caused by clogging of the well screen and gravel pack.

## 7.6 CHECK DAM

A check dam is essentially a masonry or concrete overflow type barrier constructed across the stream having well defined banks with flatter bed gradient. The stream generally has a good base flow after the rainstorm.

Mainly check dams are of two types: (i) Gated Check Dam, and (ii) Non-Gated Check Dam. In gated type check dam, the barrier wall has slot openings, which allows storm flood with silt to facilitate easy discharge of flood during initial period of monsoon. After two or three storms plates are placed in the slots. Silt is removed after every four to five years in order to improve the percolation rate through streambed. Now a days fiber reinforced glass plastic gates are used because steel gates are liable to rusting action and cement-concrete blocks are too heavy to operate.

In non-gated type check dams simple masonry weir is constructed across the stream. The height of the dam is kept low so that storm flood is contained within the banks. To enhance percolation and to increase reservoir storage, regular desilting of check dam is necessary for this type of structures. The dam storage percolates down to create recharge mound, which is recovered for irrigation use. To take greater advantage of the stream flow, many times a series of check dams are constructed all along its course. (Fig. 7.8)

## 7.7 PERCOLATION TANK

A percolation tank is generally constructed in low-level wasteland or a small drain. It has well defined catchment and spillover is diverted to a nearby natural drain. It consists of earthen embankment and an overflow type masonry waste weir. Permeable formation in the reservoir bed is an essential requirement of percolation tank. The tank acts as storage of intercepted runoff, which percolates down to phreatic aquifer creating a recharge mound. The percolation time depends upon the permeability of bed formation. Normally it is expected that between two consecutive rain spells, most of the storage percolates down. This, during 2 to 3 rainfall cycles, the actual recharge gain is two to three times the storage capacity of the tank. The shape and size of the recharge mound depends on the nature of phreatic aquifer underlying the surface. This type of recharge structure is useful in area having sandstone and limestone formation underlying (Refer Fig. 7.9).

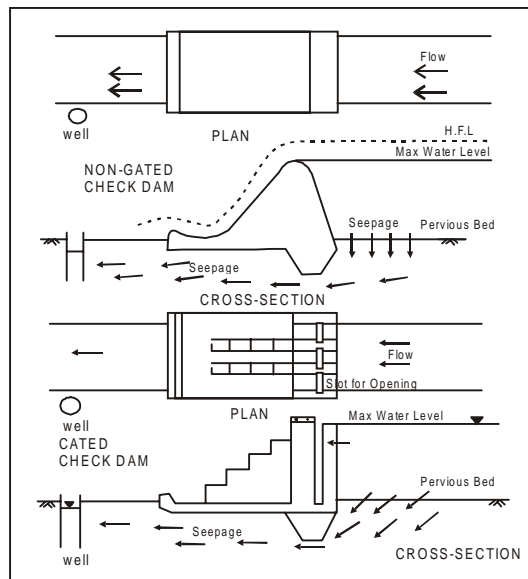

Fig. 7.8 Construction of check dam across the stream.

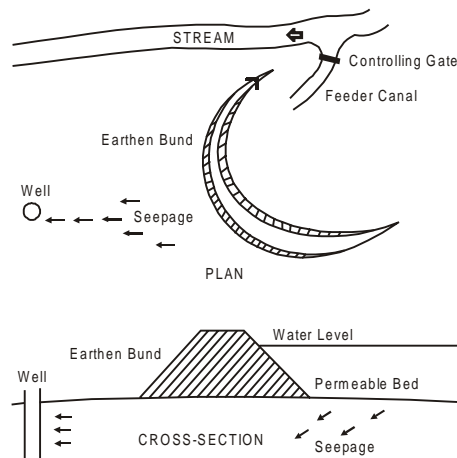

Fig. 7.9 Schematic diagram of percolation tank.

Tank is a general term used for surface water storage of moderate size. The storage may have come into being due to interception of rainwater in a natural depression or a man-made excavation. Such waterbodies are popularly called ponds. Alternatively water storage may be done by closing the openings of a natural saucer shaped landform by constructing bunds sized embankments. The storage so constructed is called a *tank*. The tank bunds are mostly constructed with earth to keep cost of construction low and commensurate with the benefits envisaged.



Water storages of large size not called tanks but they are referred to as reservoirs. Such reservoirs are formed in the river valleys by constructing a barrier or a dam using masonry, concrete or earth depending upon site conditions. Technically bund is a miniature form of a dam.

Due to simplicity in construction it was a very popular mode of conserving rainwater. In South India where river flows are monsoon fed tank assumes special importance. In the plains of Uttar Pradesh, West Bengal and Orissa as also on the plateaus of Madhya Pradesh tank can be extensively practiced.

## 7.8 CLASSIFICATION OF TANKS

Roughly bunds with less than 12 meters height create tanks. From the consideration of height of bunds, up to 4.5 meters height bunds generate small tank. Medium tanks are formed by bunds up to 9 meters height. It may, however be remembered that this classification is very approximate because shape and size of the tank is not dependent on the height of the bund alone. It is equally affected by the topographical features of the region.

### **Network of Tanks**

The tank system may exist with each tank as a separate entity or in the form of a group of tanks in a series or tanks with inter-connection. In tank system, following types of network exist:

- (i) Isolated tanks;
- (ii) Tanks with inter-connection; and
- (iii) Tanks in series.

**Isolated tanks:** When a tank is fed by an independent free draining catchment and also when the surplus flows do not form network inflow into another tank, the tank system is called isolated tank system. Mostly large and medium-large tanks are constructed as isolated tanks with independent catchment area. Also in the plains and on plateau land tanks exist in isolation.

**Tanks with inter-connection:** Sometime a group of tanks may be so situated that they could be inter-connected to receive flows through, as well as deliver flows to, other tanks in the group severally. It thereby implies that the tanks have a combined catchment. Any surplus received by a tank from the catchment lying above is transferred to other tanks. Depending upon prevailing hydro-meteorological condition the tanks are capable of feeding each other in reverse. Thus optimum water utilization is achieved.

**Tank in series:** Such tanks are located alongside the river drainage channels. They are fed by inflow drains and serviced by escape or outflow drains. The tanks in upper reaches get their supplies from the catchment through inflowing drains. It then lets its surplus flow down through an escape or outflow drain, which contributes to the inflow of the tank lower down in the series. Thus while the uppermost tanks have substantial free catchment, the tanks lower down have limited free catchment falling between two tanks. The tanks lower down in series get inflows immediately after rainfall from their free draining catchments. But supplies from already intercepted catchment are received only after the upper tanks existing in southern

States of the country from series network. The advantage of this system is that, surplus water from the upper tank does not go waste but is picked up by the lower tanks. Thus optimum water gets conserved.

It, however, suffers from one disadvantage relating to safety. Since each tanks has vast combined catchment, in case of breach in the upper tank, lower tanks also become prone to severe flooding endangering safety of the tank bund. To avoid this, breaching sections are provided at appropriate places in each tank.

### **Definitions**

Before proceeding with the subject matter it is worthwhile to understand the terms commonly used for tank.

- (i) **Free catchment:** Catchment area is defined as that area, which always contributes the surplus rainwater, received by it to the natural drainage grid present in the area. It is this area, which is responsible for maintaining flow in the natural drainages like rivers. When the catchment lying above any storage structure like a tank bund or a dam is not intercepted by another structure then it is called free catchment of that structure.
- (ii) **Breaching section:** Overtopping of tank bund by floodwater is dangerous to the safety of the bund. Hence every precaution is taken to avoid its overtopping. To achieve this object, a natural saddle on the periphery of the tank is selected. In the saddle, an ordinary retaining wall is constructed. Its height is kept higher than full tank level but lower than top of the tank bund. When the water level in the tank rises dangerously the rushing water breaches the periphery of the tank at this section. Thus the tank is protected and breach is localized to predetermined sections. If such a location is not available naturally breaching section may be constructed at a suitable site away from the bund.
- (iii) **Escape channel:** The floodwater rushes out of the breached section. To carry the outflow safely, channel of adequate capacity is provided below the breaching section. It is called and escape channel. By diverting water in the escape channel safely of the tanks on the downstream in a series network is ensured.
- (iv) **Full tank level (FTL):** It is that level up to which water is stored in the tank for utilization during fair weather. Normally full tank level (FTL) is governed by the top of the escape or surplus weir. As soon as water level starts rising above this level, water starts spilling over the weir.
- (v) **Maximum water level (MWL):** It is the level up to which the water may get stored temporarily in the tank during high flood inflows. The maximum water level (MWL) depends upon the waterway provided to pass flood discharge safely. The top of bund is generally kept above this level by keeping adequate free board.

### **Tank Bunds**

Tank bund is an embankment of low height. Generally it is made of earth. Since earth of various types is available, tank bunds may be constructed using principles adopted for construction of earth dams. Generally tank bunds of three types are constructed. They are:

- (a) *Homogeneous Type:* (Tank bund of Type A) In construction of this type uniform and homogeneous material is used. It is constructed with relatively flat side slopes from consideration of stability. Most of the bunds belong to this type (Fig. 7.10).

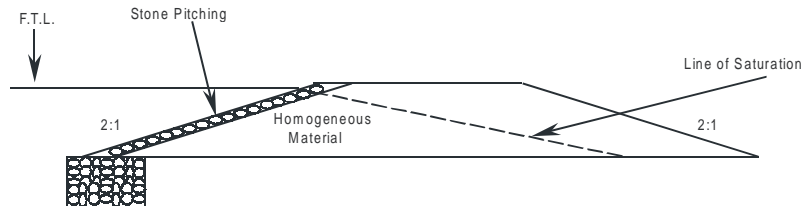

**Fig. 7.10 Homogeneous tank bund (Type – A).**

When the height of tank bund is more than 5 meters the section is modified suitably with seepage checking trenches, blankets, toe drains. Design principles of earth dams are dealt with subsequently in this book.

- (b) *Zoned Type:* (Tank bund of Type B) When earth of different types is locally available the bund may be constructed by dividing the section in different zones (Fig. 7.11).

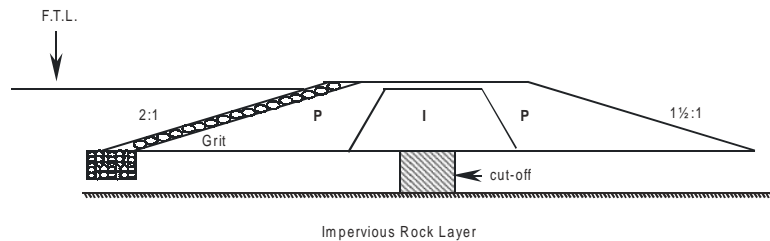

**Fig. 7.11 Zoned tank bund (Type – B).**

Outer zone is generally made of pervious material. The inner zone is made of impervious material.

- (c) *Diaphragm Type:* (Tank Bund of Type C) Many times zoning is done by providing a central core wall, called diaphragm. It is generally constructed with masonry or concrete (Fig. 7.12).

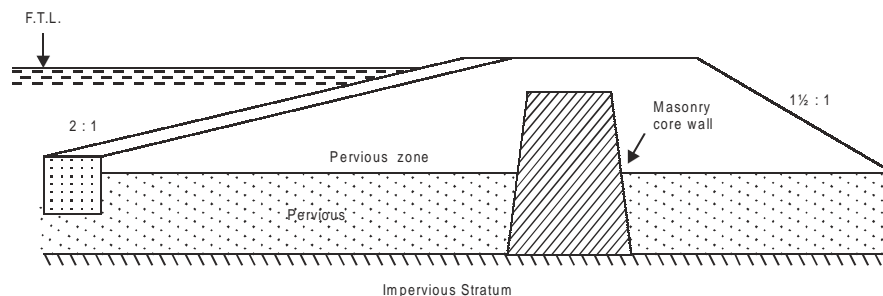

**Fig. 7.12 Tank bund with diaphragm (Type – C)**

In such types the diaphragm is taken quite deep in the foundation preferably up to impervious stratum.

### Design of Tank Bund

Although high bunds are designed on the principles for design of earth dam small tank bunds are constructed using empirical standards. Commonly adopted bund dimensions are given in Table 7.1.

Table 7.1

Height of Bund above Deep Bed (Meters)	Free Board (Meters)	Top Width (Meters)
More than 7.5	1.8	2.7
6.0 to 7.5	1.5	1.8
4.5 to 6.0	1.2	1.5
2.5 to 4.5	0.9	1.2

The side slope of Tank bund is kept quite flat. 2:1 (Horizontal: Vertical) is a common slope. However for lesser heights steeper slopes may be adopted.

Like earth dams the upstream face of the tank bund is generally given stone pitching. It is also called revetment. Thickness of the pitching may vary from 0.3 to 0.6 meters. A toe is also provided to support the sloping face. General arrangement is shown in Fig. 7.13.

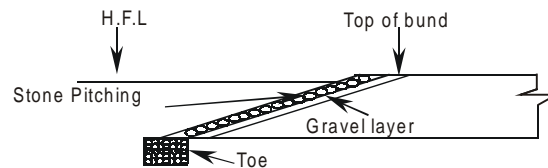

Fig. 7.13 Stone pitching of tank bund.

**Storage capacity of a tank:** Storage capacity of a tank can be calculated using trapezoidal formula. It is stated as:

$$V = H/3 (A_1 + A_2 + \sqrt{A_1 - A_2})$$

Where V is volume of space enclosed between two adjacent contours.

$A_1$  &  $A_2$  are the areas enclosed in two contours.

H is contour interval.

This method is useful in finding capacity in two successive contours only. But since tank bunds are of small heights the method is quite useful. The effective or utilization storage in a tank is the volume between level of sill of the outlet or lowest sluice and full tank level.

### **Escape Weirs**

It is already mentioned that tanks are small storage works constructed to meet local requirements. Obviously attempt is not made to contain full runoff coming down from the catchment area. It is therefore necessary to make suitable arrangement to pass down excess water beyond Full Tank Level (FTL) safely. Structure constructed to provide passage to excess water is called escape weir. It is also called tank surplus weir. The water starts spilling over the weir as soon as tank is filled up to its crest. However temporarily due to rush of incoming water the level in the tank rises above F.T.L. The new level reached is called Maximum Water Level (MWL). It depends on the extent of flood. For design purposes M.W.L. is calculated taking into account maximum flood discharge likely to occur and the waterway available at the site of the escape weir. The surplussing or spilling water is carried down through a channel, which is generally a natural drainage and has enough capacity.

**Selection of site for a tank weir:** Following points may be taken into consideration while selecting a site for a tank weir: -

- (i) Tank weir performs the function of surplussing excess flow. Therefore it is preferable to locate the weir in a natural saddle away from the tank bund.
- (ii) To carry surplus flows existence of a well-defined escape channel is very necessary at a site selected for construction of a weir.
- (iii) The saddle, where Natural Surface Level (NSL) is approximately same, as full tank level (FTL) should be given first preference.
- (iv) Hard foundation if available at the site reduces the cost of construction of bed protection works.
- (v) When a site away from tank bund is not available, as far as possible weir may be located on one end of the tank bund.
- (vi) Surplus weir may be housed in the body of the tank bund only as a last resort.
- (vii) Care should be taken to see that escape channel carrying surplussing water is not likely to damage cultivated areas.

**Types of weirs:** Escape weirs constructed in tank irrigation system is similar to a diversion weir or an anicut constructed across the river channel. It may be constructed either with masonry or rockfill or concrete depending upon availability of construction material and site conditions.

**Masonry weirs:** This type of weir is most commonly used in a tank irrigation system. Masonry weirs are generally constructed with vertical drop and are designed as gravity weirs. Self-weight of the body wall is the only restoring external force and it counteracts all dislodging forces like water pressure, uplift etc. On the body wall of the weir dam stones may be erected to enable extra storage. Depending upon the site conditions, masonry weirs may be constructed in three ways as given below.

(a) **Masonry weir with horizontal floor:** In this type of weir, vertical drop is given as shown in Fig. 7.14.

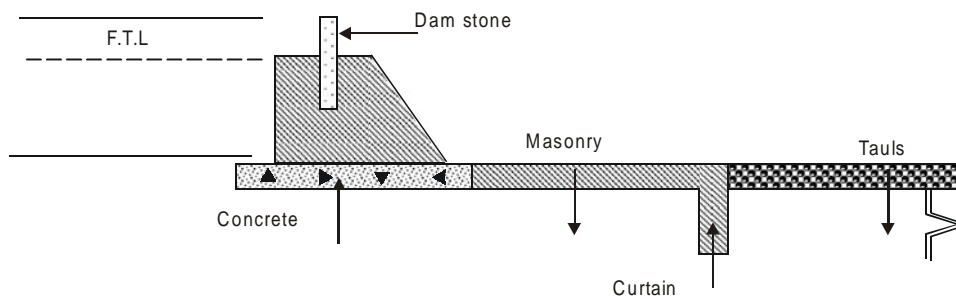

Fig. 7.14 Masonry weir with horizontal floor.

This type is suitable when on the downstream side hard rock is available in the foundation and the height of the weir is less than one meter or so.

- (b) **Masonry weir with depressed floor:** This type is similar to one explained above except that the downstream apron is depressed below the ground level. Fig. 7.15.

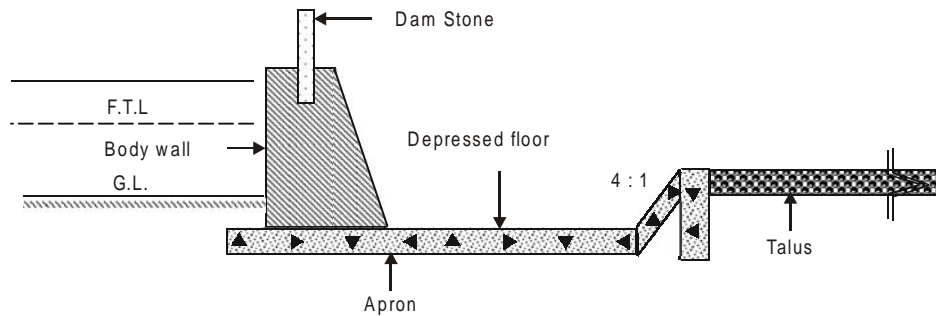

Fig. 7.15 Masonry weir with depressed floor.

By depressing the apron below ground level a sort of stilling pond is formed. It helps in dissipating the energy of water spilling over the crests of the weir. This type of arrangement is generally used for weirs with greater heights say more than 2.5 meters. They are then designed like a fall.

- (c) **Masonry weir with stepped floor:** When the topography is such that there is no space for constructing horizontal or depressed horizontal apron, weir with stepped apron may be constructed as shown in Figure 7.16. It is something like steps and is suitable for low heights of body wall.

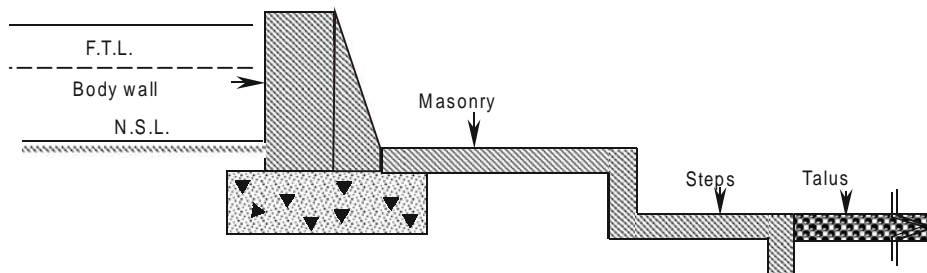
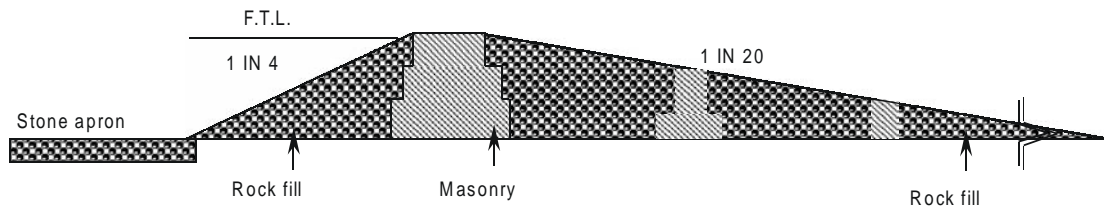

Fig. 7.16 Masonry weir with stepped apron.

**Rockfill weirs:** It is constructed with dry rock fill if such material is locally available in sufficient quantity. Fig. 7.17.

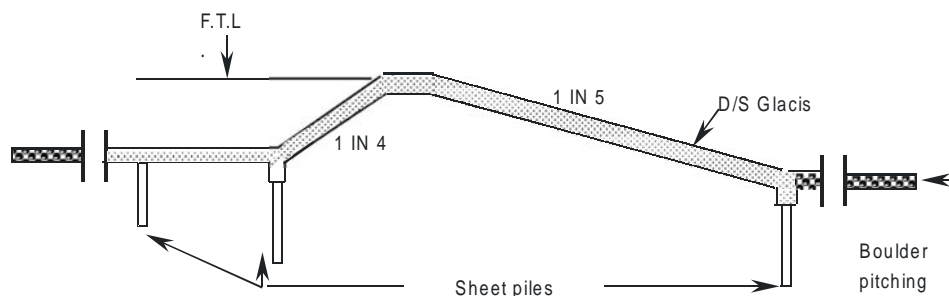

**Fig. 7.17** Rock fill weir.

To support the rock fill masonry retaining walls are constructed as shown in the fig. 7.17. Top surface of the weir is plastered. This type of weir acquires a very big section because the slopes are quite flat.

**Concrete weirs:** Typical profile is shown in Fig. 7.18. The weir is constructed with reinforced concrete to make the section monolithic. This type is constructed mostly where foundations are pervious.

In this type of weir, a sloping glacis is provided on the downstream side. It helps in creating a hydraulic jump on the sloping face. When hydraulic jump is created the energy of flow is dissipated. Thus the bed is protected below the weir.



**Fig. 7.18** Concrete weir.

### Design of Tank Weirs

**Maximum flood discharge of tank:** Since the weir has to safely pass down excess flow, estimation of peak flow becomes a first step in design of tank weirs. Catchment area of tank is small and fan shaped, so in practice, is difficult to measure the discharge. It is, therefore, estimated using empirical formulae. In north India Dicken's formula is used, while for south India Ryve's formula has been developed. Ryves formula is stated as below: -

$$Q = C.M^{2/3}$$

Where  $Q$  is peak flow in cumec

M is catchment area in sq km

C is a constant

= 6.74 for areas within 24 km from coast

= 8.45 for areas with in 24-161 km from coast

= 10.1 for limited hilly areas.

This formula can be applied for a free catchment. For a tank in series or interconnected tanks the formula needs correction. Modified formula is

$$Q_m = CM^{2/3} - C_m \cdot M_m^{2/3}$$

Where  $M_m$  is the catchment area in sq km intercepted by upstream tank

$C_m$  is new coefficient, which varies from 0.2 to 0.33.

*Waterway of the weir:* The weirs constructed are generally broad crested weirs and the formula, which gives discharge over broad crested weir, can be used. Generally velocity of approach is neglected. The discharge formula is in the form –

$$Q = C.L.H^{3/2}$$

$$L = Q / C.H^{3/2}$$

Where L is length of weir in meters

H is design head over weir; it is given by (MWL – FTL) in M

C is a constant

= 1.84 for weir crest up to 0.9 m width.

= 1.66 for weir crests more than 0.9 m width.

= 1.66 for crests with dam stones.

= 1.47 for crests with d/s sloping face.

**Length of apron:** Usually length of horizontal downstream apron is kept  $2(D + H)$  from toe of body wall. Here D is height of the body wall above floor and H is maximum water head over the crest of the wall. A further factor of safety of 1.5 is provided when important areas lie below the surplus weir. Then length is kept  $3(D + H)$ .

**Length of stone talus or pitching:** Generally  $3(D + H)$  to  $5(D + H)$  length of stone pitching is provided on the downstream of apron in continuation. Greater length is provided for weaker foundation material.

### **Rehabilitation and Modernization of Tanks**

There has been heavy siltation in large number of tanks. Surveys indicate that the water holding capacity of these tanks has been reduced by about one-third due to siltation, completely eliminating dead storage and reducing infiltration. In olden times village community did periodical desilting. In present set-up, such social obligation no more exists. In short, the up keep of the tanks have been neglected and their capacity is reduced due to siltation.



To restore the lost area under storage and to increase the tank area there is urgent need to rehabilitate and modernize the age – old tanks. Rehabilitation can be achieved by desilting the tank. Modernization involves strengthening and raising height of bund, improvement of surplussing arrangement, minimizing evaporation losses.

### Design Problems

**# 1:** Free catchment of an isolated tank is 50 sq km. Average annual rainfall recorded is 100 cm, nearly 80% of which occurs in a short period of two months and the rest is distributed over balance period. Taking dependability of average year rainfall to be 60% calculate the gross storage capacity required for the tank. Assume that only 30% of the rainfall flows down as surface run-off. Also calculate design flood likely to be generated by the catchment. Area is within 80 km from coast.

*Step 1:* Average annual rainfall = 100 cm

For calculating storage capacity, we may use only that part of runoff, which occurs in the rainy season because it is stated that balance rainfall is distributed over a 10 month period and may produce insignificant runoff. It will be accommodated in vacant space of the tank.

$$\text{Effective rainfall} = 80 \times \frac{100}{100} = 80 \text{ cm}$$

*Step 2:* In the question dependability level is given to be 60% of average flow,

$$\text{Dependable rainfall} = 80 \times \frac{60}{100} = 48 \text{ cm}$$

*Step 3:* Runoff factor is given to be 30% of rainfall

$$\text{Runoff expected at bund site} = 48 \times \frac{30}{100} = 14.40 \text{ cm}$$

$$\begin{aligned} \text{or Gross storage capacity required} &= \frac{14.40}{100} \times 50 \times 1000 \times 1000 \\ &= 7.2 \times 10^6 \text{ cubic meters} \end{aligned}$$

*Step 4:* Design flood can be calculated using Ryve's formula

$$Q = C M^{2/3}$$

Where Q is peak flood in cubic meters

C can be taken to be 8.45

M is 50 sq. km

$$Q = 8.45 \times 50^{2/3} = 114.68 \text{ cubic meters}$$

**#2:** In the catchment of problem 1, another tank has been constructed on the upstream. Free catchment of new tank is 10 sq km. Calculate modified gross storage capacity and design flood as also percent reduction for the existing tank. Assuming that upstream tank releases 1/5<sup>th</sup> of its runoff.

*Step 1:* Free catchment of the existing tank = 50 – 10 = 40 sq km

Intercepted catchment = 10 sq km  
 Runoff in tank = 14.40 cm (from step 3 of problem 1)

*Step 2:* Modified runoff into existing tank  
 = Runoff from free catchment + 1/5 (runoff from intercepted catchment)  
 =  $5.76 \times 10^6 + 0.288 \times 10^6$   
 =  $6.048 \times 10^6$

*Step 3:* % reduction in storage =  $\frac{7.2 - 6.048}{7.2} \times 100 = 16\%$

*Step 4:* Modified design flood is given by using the relation  $Q_m = C.M^{2/3} - C_m.M_m^{2/3}$

Where  $C_m = 0.2 C$  and  $M_m$  is 10 sq km

$$\begin{aligned} Q_m &= 8.45 \times 50^{2/3} - 0.2 \times 8.45 \times 10^{2/3} \\ &= 114.68 - 7.84 \\ &= 106.84 \end{aligned}$$

*Step 5:* % Reduction

$$\text{In design flood} = \frac{114.68 - 106.84}{114.68} \times 100 = 6.84\%$$

## 7.9 FLOODING METHODS

The flooding method involves diversion of water to form a thin sheet flowing over relatively flat land. Flow rate should be minimum so as not to disturb vegetation and soil covering and highest infiltration rate can be achieved. Peripheral dikes or ditches should surround the entire flooding area (Refer Figs. 7.19 & 7.20).

Following factors should be observed:

- I. The velocity of flow should be minimum possible so as not to disturb the vegetation and soil cover.
- II. If we assume that land is available without cost then this method is cheaper.
- III. For maximum efficiency, manual labour should be employed.

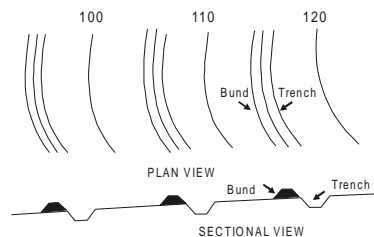

**Fig. 7.19 Schematic diagram of contour bunding.**

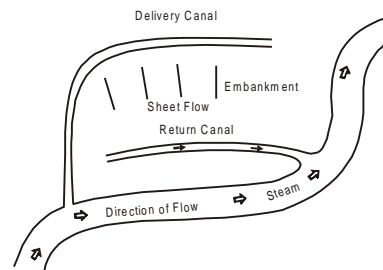

Fig. 7.20 Flooding technique of recharge.

## A – II: SUB-SURFACE METHODS

Sub-surface techniques are very much useful when there is a low permeability between the ground surface and the unsaturated upper level of the recharged aquifer. Generally, these techniques are useful when surface methods cannot be satisfied technically and economically. The following are some sub-surface techniques of recharge:

- ◆ Recharge through wells.
- ◆ Recharge through pits and shafts.

Sub-surface methods have following advantages:

1. They occupy smaller area.
2. Utilize better quality recharge water.
3. They are capable of recharging confined aquifers.
4. They can be designed to avoid mixing of recharge and pumped water.

### Recharge Through Wells

This structure is generally constructed in streambed and on upstream side of possible check dam across the stream. It consists of 8-10 deep bore wells of 300 mm diameter with 200 mm slotted PVC pipe and annular space filled with sand and gravel. Water can be recharged underground through wells where deep confined aquifers or space limitations preclude application of other methods. Considerable care should be taken in operation and construction of recharge wells to minimize the effects of clogging which may take place because of entrapment of finer aquifer particles, from filtration of suspended materials in the recharge water, from bacteria and from chemical reaction between recharge and ground water. Generally, gravel packed wells can recharge more efficiently. Recharge water should be clear, should not have high sodium content, and should be chlorinated (Figs. 7.21 & 7.22).

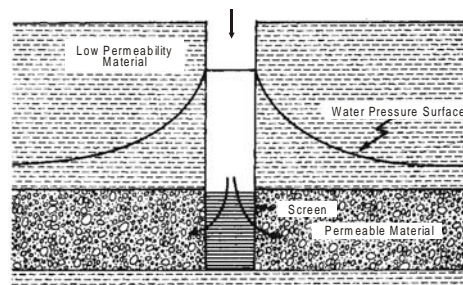

Fig. 7.21 Recharge (Injection) well for unconfined aquifer.

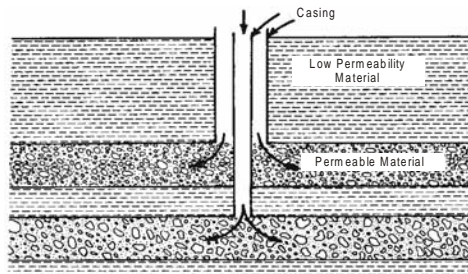

Fig. 7.22 Recharge (Injection) well serving several aquifers.

### Recharge Through Pits and Shafts

Recharge through pits method is useful at a place where there is shallow impermeable strata, which can be excavated in due course to open up permeable strata, which lies below it, and small recharging pit like structure is created. Abandoned gravel pits and pits formed by sale of excavated material are useful locations. Provision should be made to remove the silt accumulation periodically (Figs. 7.23 & 7.24).

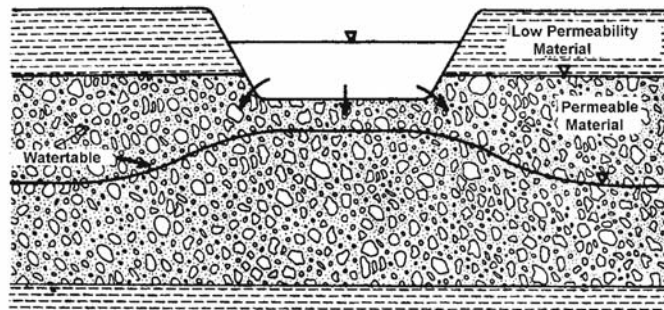

Fig. 7.23 Recharge pit.

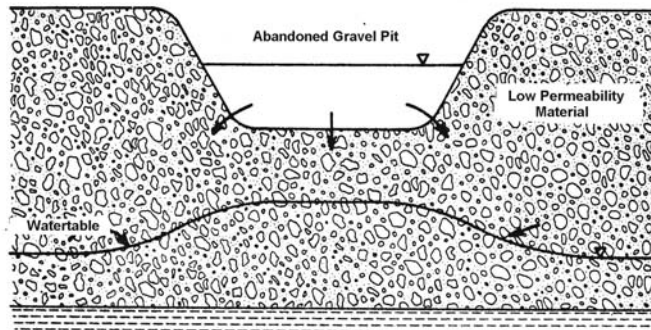

Fig. 7.24 Abandoned gravel pit.

Unfortunately, pits used for storage or treatment of liquid wastes provides a significant source of inadvertent recharge, which leads to complex and widespread problems of groundwater pollution. Examples include sewage treatment lagoons, industrial waste holding or disposal ponds and oil field brine evaporation pits, to mention only a few of an exceedingly large number of practical situations.

Recharge shafts (Fig. 7.25) are generally deeper and of smaller diameter than pits. Their purpose is also to penetrate low permeability layers. Shafts may be lined or unlined, open or filled with coarse material and large or small. They are constructed by hand, with draglines and backhoes or are drilled or bored where the recharge water contains sediment, shafts may become plugged fairly rapidly.

Commonly, recharge shafts are used in conjunction with pits (Fig. 7.26). Both suffer from decreasing recharge rates with time due to the accumulation of fine-grained materials and to the plugging effect brought about by microbial activity. Rates through recharge pits may be maintained by periodically allowing the facility to become dry or by scraping and removing the accumulated material from the sides and bottom. Shafts are less easy to maintain owing to their smaller diameter and greater depth. In some cases, the coarse material used to fill the shaft must be replaced.

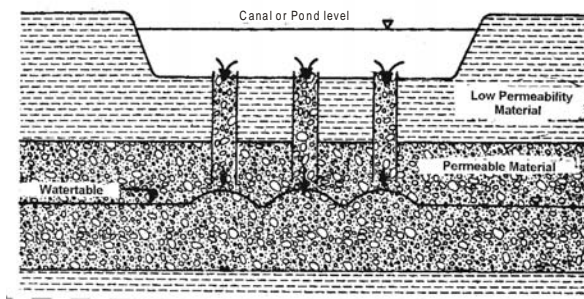

Fig. 7.25 Recharge shafts.

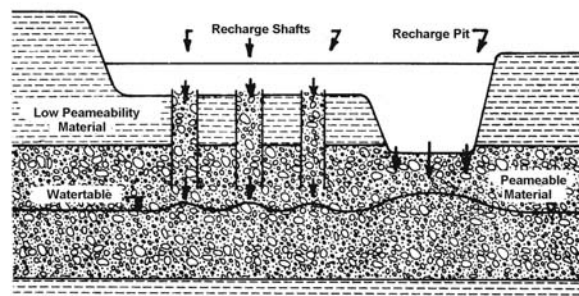

Fig. 7.26 Combination of recharge shafts and recharge pits.

### Spreading Above Groundwater Table

In practice, the groundwater table may be so far below the ground surface that the available difference in head between this table and the water level in the spreading ditch cannot fully be utilized. With the circular spreading scheme of the last section, this is, for instance, the case when  $S_0$  in Figure 7.5 is larger than 8.95 m. With very coarse-grained aquifers, an unsaturated zone between the bottom of the spreading ditch and the top of the groundwater mound could now occur, as shown in Fig. 7.27.

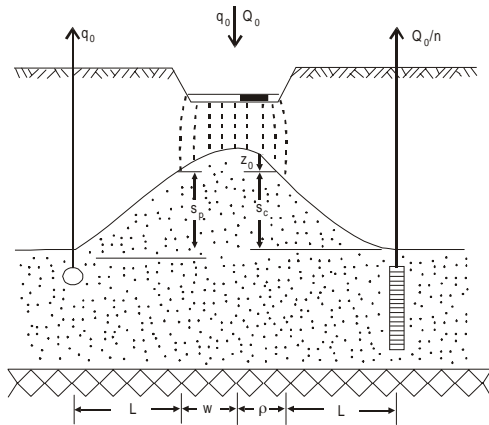

Fig. 7.27 Spreading ditch above the groundwater table.

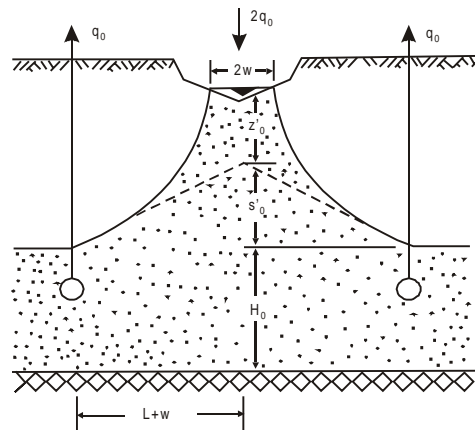

Fig. 7.28 Spreading ditch above the groundwater table.

For parallel and circular systems respectively, the head loss here is given by

$$S_p = \frac{q_0}{kH} L, S_c = \frac{Q_0}{2\pi kH} \ln \left( \frac{L+\rho}{\rho} \right); Z_0 = \frac{1}{2} \frac{q_0}{kH} w; Z_0 = \frac{Q_0}{2\pi kH}.$$

With finer grained aquifers on the other hand, the air present in the pores of the formation will be dissolved and carried on by the downward percolating recharge water, while re-supply of air from the ground surface will be too limited to maintain an unsaturated zone. A closed body of groundwater will thus be formed, shown in Fig. 7.28. For a clean ditch without clogging, its necessary width is given by (Vermeer, 1974):

$$2w' = \frac{2q_0}{k} + \frac{4}{\pi} (H_0 + S'_0) e^{-\pi k z'_0 / (2q_0)}$$

$$\text{with } S'_0 = \frac{q_0}{\pi k} (L + W)$$

whereas for a clean circular pond without clogging (Fig. 7.29), the necessary diameter,  $2\rho$ , may be

calculated by trial and error from  $S_0 = S_1 + S_2 = \frac{Q_0}{2\pi kH} \left[ \ln \left( \frac{L+\rho}{\rho} \right) + \alpha \right]$ , with  $\alpha$  is a function of

$2\rho/H$ . For instance,  $Q = 20 \times 10^6 \text{ m}^3/\text{year} = 0.634 \text{ m}^3/\text{s}$ ,  $k = 0.4 \times 10^{-3} \text{ m/s}$ ,  $H = 50 \text{ m}$ ,  $L + \rho = 500 \text{ m}$ , the distance from the ground surface to the groundwater table  $S_0 = 10 \text{ m}$  and moreover, so

$$(L + \rho)/\rho = [2(L + \rho)/H][H/(2\rho)], \text{ so}$$

$$\ln\left(\frac{L + \rho}{\rho}\right) = \ln\left[\frac{2(L + \rho)}{H}\right] + \ln\left(\frac{H}{2\rho}\right), \text{ then}$$

$$10 = \frac{0.634}{2\pi \times 0.4 \times 10^{-3} \times 50} \left[ \ln\left(\frac{2 \times 500}{50}\right) + \ln\left(\frac{H}{2\rho}\right) + \alpha \right], \text{ or}$$

$$\alpha = \ln(2\rho/H) - 1.01$$

With the approximation for  $\alpha$ , this yields by trial and error

$$2\rho/H = 3.67 \text{ or } \rho = 92 \text{ m}$$

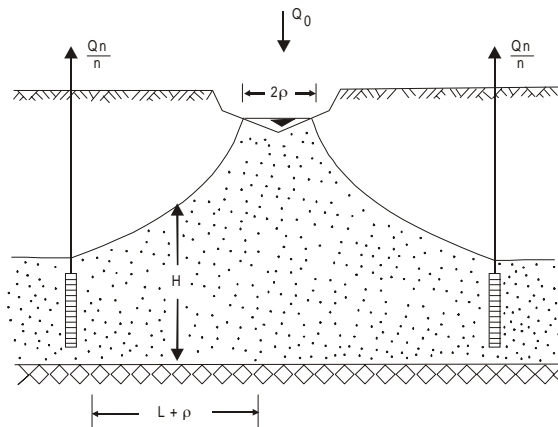

Fig. 7.29 Spreading pond above the groundwater table.

**By Constructing Subsurface Dyke: (Fig. 7.30)**

This can be achieved by constructing subsurface dike in the streambed. These subsurface barrier will stop the under ground flow below the bed level. It extends upto impermeable layer below the streambed and thus one phreatic aquifer is created.

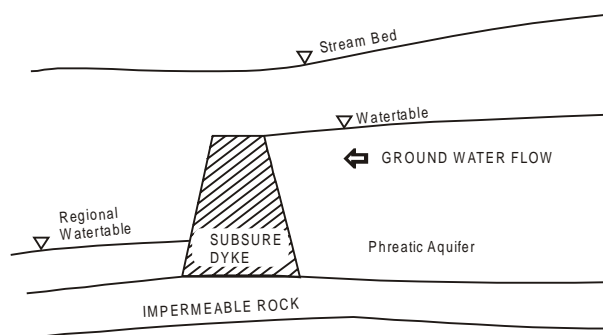

Fig. 7.30 Subsurface dyke.

## 7.10 INDIRECT METHODS

Indirect methods of recharge are meant to include type of recharge that is induced by pumping from an aquifer hydraulically connected to a surface reservoir, a river, a canal or another aquifer. Although these techniques have limited applications if compared to the direct methods, its usefulness in certain localities is beyond comparison.

**Induced Recharge:** (Figs. 7.31 & 7.32).

Induced recharge is water entering the ground from a surface water source as a result of withdrawal of groundwater adjacent to the source illustrates how a well pumping near a stream induces flow into the ground. Thus wells, infiltration galleries, and collector wells located directly adjacent to and fed largely by surface water cause surface water to be recharged underground. The method is useful in locations where surface waters may not be of high quality and large groundwater reservoirs are not available.

Induced recharge supplies depend, to a large extent, on the quantity of water that can be diverted from a stream or lake. Pumping a streamside well establishes a hydraulic gradient from the surface to the well. Both vertical and horizontal wells are used for this purpose. The controlling factor, other than a dependable source of surface water of acceptable quality, is the permeability of the streamside deposits and the sediment on the bottom of the stream. In areas where the stream is separated from the aquifer by materials of low permeability, leakage from the stream may be so small that the system is not feasible.

The permeability of a stream bottom fluctuates throughout the year. During periods of low flow, mud and organic matter accumulate in the channel forming a bed of low permeability that reduces infiltration. The channel is scoured during high flows the rate of infiltration can vary by 50 % or more between periods of high and low flows. In many places and particularly during droughts or extended dry periods stream discharge is not sufficient to erode the fine materials from the channel bottom. Dredging may rectify this situation.

Where saturated streamside deposits are thin, horizontal wells may be more feasible and appropriate than vertical wells. Laterals, which radiate from a central collector well can be injected so that they lie close to the bottom of the aquifer and allow the maximum amount of draw down.

An important consideration in induced recharge is the chemical quality of the surface water source. Since a considerable percentage of the water discharged from the well may be derived directly from a stream its chemical quality gets reflected. Induced infiltration from a contaminated stream may seriously degrade a groundwater supply.

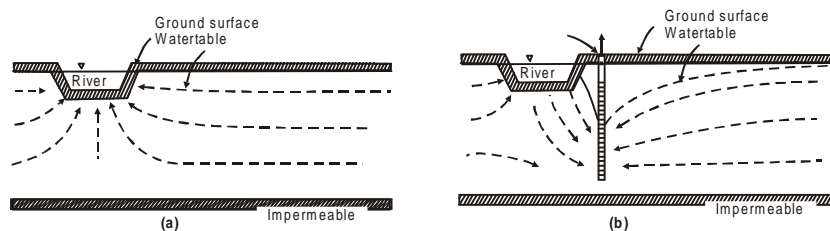

**Fig. 7.31** Induced recharge resulting from a well pumping near a river  
(a) Natural flow pattern (b) Flow pattern with pumping well.



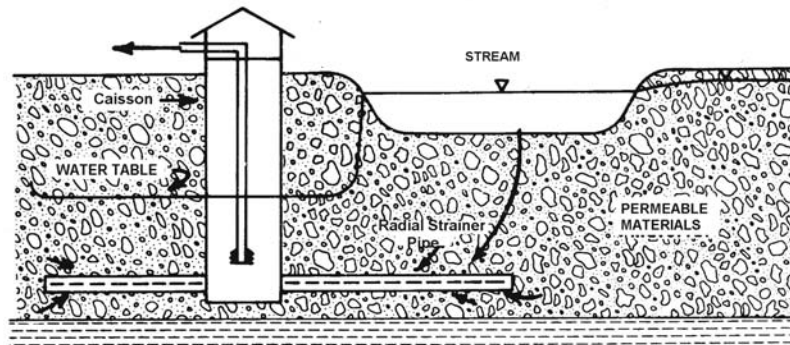

Fig. 7.32 Induced recharge resulting from a collector well on stream bed.

### Hydraulics of Induced Recharge

Apart from geohydrological constants, which cannot be altered, induced recharge is governed by two factors: the rate,  $q_0$ , of groundwater abstraction from the gallery and the influent river (Fig. 7.33). These factors, however, cannot be chosen at will but must satisfy various requirements. To prevent a rapid clogging of the streambed, the rate at which the river water enters the aquifer must be low. To assure a satisfactory purification of the river water during its underground flow towards the gallery, the distance of travel must not be too small (not less than 50 – 100 m) and the detention time, in particular, must exceed a minimum value of 30 – 60 days, depending on local circumstances. In order not to hinder other groundwater users more than the minimum value is strictly necessary, the lowering of the groundwater table finally must be limited. With the notation in Fig. 7.33 and assuming a homogeneous and isotropic aquifer with a constant coefficient of transmissivity,  $kH$ , and the interval  $L$  small compared to the aquifer width  $W$ , as it usually is, these requirements may be formulated as follows:

$$q_0 < \Omega v_e$$

$$q_0 < pHL/T$$

$$q_0 < kHS_0/L$$

with, again assuming  $L \ll W$ ,

$$q_0 = q_a + q_n; q_n = \frac{1}{2} PW + (kHS_0/W)$$

In these formulas,  $W$  is the wetted circumference of the river bed in contact with the aquifer,  $v_e$  the maximum allowable value for the average entry rate of river water into the subsoil,  $p$  the pore space,  $H$  the saturated thickness and  $k$  the coefficient of permeability of the aquifer,  $T$  the minimum acceptable detention time,  $P$  the amount of residual rainfall and  $S_0$  the maximum value of the drawdown,  $S$ , which increases linearly with the distance from the bounding rivers. With regard to the requirements for the detention time and drawdown, no compromise is possible, giving for the interval  $L$

$$L > q_a T / (pH) \text{ and } L < kHS_0 / (q_a + q_n)$$

$$\text{or } L = \sqrt{\left(\frac{q_a}{q_a + q_n}\right) \frac{k}{p}} S_0 T$$

With  $q_a$  a few to many times larger than  $q_n$ , say  $q_a \simeq 4q_n$ , this formula may be simplified to

$$L = 0.9 \sqrt{(k/p)} S_0 T$$

Assuming, for instance, n aquifer with  $W = 6000$  m,  $H = 22$  m,  $k = 0.4 \times 10^{-3}$  m/s,  $p = 0.4$  and  $P = 16 \times 10^{-9}$  m/s (500 mm/year) and requiring a detention time,  $T_d$ , longer than  $6 \times 10^6$  s (70 days) and a drawdown,  $S_0$ , not exceeding 1.5 m, the distance  $L$  becomes:

$$L = 0.9 \sqrt{\frac{0.4 \times 10^{-3}}{0.4} \times 1.5 \times 6 \times 10^6} \approx 85.38 \text{ say } 85 \text{ m}$$

Starting from this value, the requirements for the detention time and drawdown give

$$q_a < \frac{0.40 \times 22 \times 85}{6 \times 10^6} \text{ or } q_a < 124.67 \times 10^{-6} \text{ m}^3 \text{m}^{-1} \text{s}^{-1}$$

$$q_0 < 0.4 \times 10^{-3} \times 22 \times 1.5/85 \text{ or } q_0 < 155.29 \times 10^{-6} \text{ m}^3 \text{m}^{-1} \text{s}^{-1} \text{ and with}$$

$$q_n = \left( \frac{1}{2} \times 16 \times 10^{-9} \times 6000 \right) + [0.4 \times 10^{-3} \times 22 \times (1.5/6000)]$$

$$= (48 \times 10^{-6}) + (2.2 \times 10^{-6})$$

$$q_n = 50.2 \times 10^{-6} \text{ m}^3/\text{ms}$$

$$q_a < (155 \times 10^{-6}) - (50 \times 10^{-6}) \text{ or } q_a < 104.8 \times 10^{-6} \text{ m}^3 \text{m}^{-1} \text{s}^{-1}$$

$$\text{or } q_a < 105 \times 10^{-6} \text{ m}^3 \text{m}^{-1} \text{s}^{-1}$$

As the smaller of the two values for  $q_a$ , this is the deciding one, giving with a river width of, for instance, 40 m an average entry rate into the sub-soil equal to

$$v_e = 105 \times 10^{-6} / 40 = 2.62 \times 10^{-6} \text{ m/s}$$

or 0.2 m/day, which seems quite acceptable. For a city of 100 000 inhabitants, with a daily consumption of 20 000 m<sup>3</sup> or on average 0.23 m<sup>3</sup>/s, the gallery yield of  $133 \times 10^{-6} \text{ m}^3 \text{m}^{-1} \text{s}^{-1}$  means a length of bank infiltration equal to

$$B = \frac{0.262}{155 \times 10^{-6}} \approx 1690 \text{ m}$$

for which it will not be difficult to find an appropriate place. Slightly better results in this respect could be obtained by a small reduction in the value of  $L$ , from 90 to 84 m, increasing the gallery yield to  $143 \times 10^{-6} \text{ m}^3 \text{m}^{-1} \text{s}^{-1}$  and decreasing the required gallery length to 1600 m.

Without saying so expressly, the calculations carried out so far are based on a one-dimensional flow pattern, showing only horizontal flow lines perpendicular to the river. Such

a flow net would indeed be present when the length of the gallery parallel to the river is infinite and when both the gallery and the river fully penetrate the saturated thickness of the aquifer and, moreover, do so with vertical sides. This, however, will never be the case, slightly changing the results obtained above.

For the water flowing directly beneath the water table, the detention time will be somewhat smaller than the value of  $T_d$  assumed so far, but for all other flow lines the detention time will be longer, giving an average value appreciably above the design value. Due to a greater length of flow and to the presence of vertical flow components, the drawdown,  $S_0$ , will increase by  $\Delta s$ . With a fully penetrating gallery of zero width in the centre of the river, the length of flow,  $L$ , increases by  $\Omega/2$ , augmenting the drawdown to

$$S_0 = \frac{q_0}{kH}L, \text{ by } \Delta S_1 = \frac{q_0}{kH} \frac{\Omega}{2}$$

Replacing the fully penetrating gallery by the real one gives an additional drawdown due to partial penetration

$$\Delta S_2 = [q_0/(\pi k)] \ln (H/\Omega)$$

For the correct example quoted above

$$S_0 = \frac{155 \times 10^{-6}}{0.4 \times 10^{-3} \times 22} \times 85 = 1.50 \text{ m}$$

$$\Delta S_1 = \frac{155 \times 10^{-6}}{0.4 \times 10^{-3} \times 22} \frac{40}{2} = 0.35 \text{ m}$$

$$\Delta S_2 = \frac{155 \times 10^{-6}}{\pi \times 0.4 \times 10^{-3}} \ln \left( \frac{22}{40} \right) = -0.07 \text{ m}$$

$$\Sigma S_0 = 1.50 + 0.35 - 0.07 = 1.78 \text{ m}$$

It should be noted, moreover, that according to Fig. 7.33, the entry of river water is concentrated near the shoreline. In extreme cases, clogging will occur here, shifting the recharge towards the centre of the streambed, thus increasing the length of flow and the drawdown. To prevent this as much as possible, the design rate of entry should be chosen small.

Due to the finite length of the gallery and the additional inflow around the far ends, the capacity for the same drawdown will be larger, equal to  $\alpha Bq_0$  with  $\alpha$  equal to

B/L	2	5	10	20	50	100
$\alpha$	2.29	1.65	1.39	1.23	1.13	1.07

For the same capacity, the drawdown will correspondingly be smaller. In the example mentioned above,

$$B/L = 1700 / 85 = 20, \alpha = 1.23$$

$$\text{Giving } \Sigma S_0 = 1.78/1.23 = 1.45 \text{ m}$$

Well below the maximum allowable value of 1.50 m. Incidentally, due to clogging and partial penetration of the gallery, the piezometric level of the water inside the gallery is lower than that which corresponds with the drawdown of 1.45 m. The influence of partial penetration may again be calculated as

$$\Delta S' = [q_0 / (\pi k) \ln (H / \Omega')]$$

with  $\Omega'$  as the wetted perimeter of the gallery. With a gallery of, say, 0.6 m diameter, this gives for the case under consideration

$$\Delta S' = \frac{155 \times 10^{-6}}{\pi \times 0.4 \times 10^{-3}} \ln \left( \frac{22}{\pi \times 0.6} \right) = 0.30 \text{ m.}$$

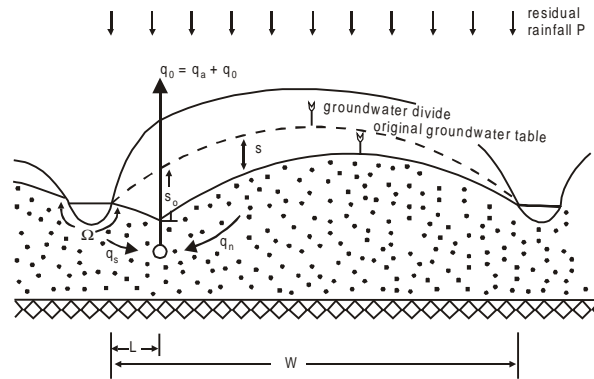

Fig. 7.33 Hydraulics of induced recharge.

The influence of clogging cannot be calculated, but it is wise to anticipate a value of 0.5 – 1 m, keeping in mind that cleaning of the gallery is impossible.

The calculations made so far are based on a constant water level in the bounding rivers. When these water levels vary, a change in groundwater levels will also occur, influencing the ratio between artificial and natural groundwater abstracted. In the case where the river shows a sinusoidal variation (Fig. 7.33),  $z = z_0 \sin(\omega t)$ , then assuming that  $W$  is so large that mutual interference may be neglected, the variation in river water abstraction,  $q_a$ , equals

$$\Delta q_a = \sqrt{\omega \mu k H} Z_0 e^{-\alpha L} \sin\left(\omega t - \alpha L + \frac{1}{4} \pi\right), \text{ with } \alpha = \sqrt{\frac{1}{2} \omega \mu / (kH)}$$

With the example described before,  $\mu = 0.30$ , yearly fluctuations and  $Z_0 = 1.5 \text{ m}$

$$\Delta q_a = \sqrt{\frac{2\pi}{31.54 \times 10^6}} \times 0.30 \times 8 \times 10^{-3} (1.5 e^{-84/517}) = \pm 28 \times 10^{-6} \text{ m}^3 \text{ m}^{-1} \text{ s}^{-1}$$

With a steady state river water abstraction equal to  $q_a = 101 \times 10^{-6} \text{ m}^3 \text{ m}^{-1} \text{ s}^{-1}$ , this amount will now vary between  $73 \times 10^{-6} \text{ m}^3 \text{ m}^{-1} \text{ s}^{-1}$  and  $129 \times 10^{-6} \text{ m}^3 \text{ m}^{-1} \text{ s}^{-1}$ , making 51 to 90% of the gallery yield,  $q_0$ , of  $143 \times 10^{-6} \text{ m}^3 \text{ m}^{-1} \text{ s}^{-1}$ .

**Incidental Methods: (Fig. 7.34)**

Incidental recharge includes non-deliberate replenishment from irrigation system, leaking domestic and industrial systems and disposed industrial and domestic waste waters. In spite of its significant contribution to the groundwater, this last method was the least investigated technique.

The incidental recharge occurs where water enters the ground due to activities whose objective is not artificial recharge (Todd, 1985). Examples include water from irrigation, septic tanks, water mains, waste-disposal facilities.

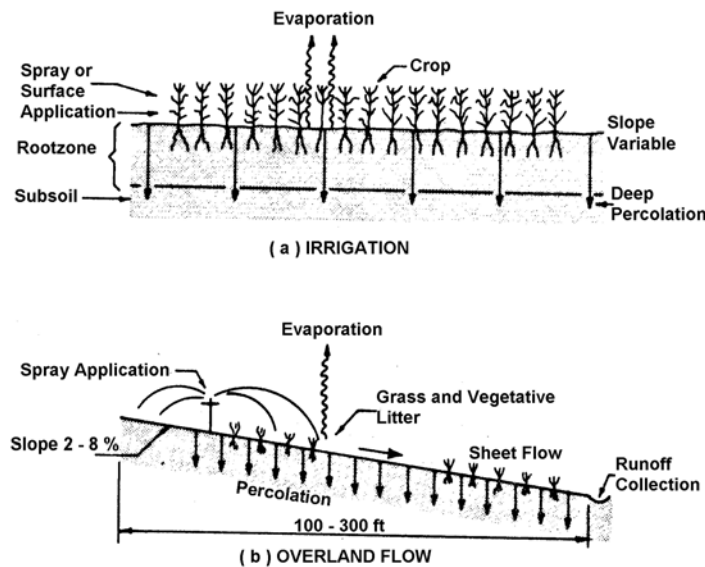

Fig. 7.34 Incidental recharge by (a) Irrigation (b) Overland flow.

## 7.11 METHODS OF ARTIFICIAL RECHARGE PRACTICED BY PEOPLE IN DROUGHT PRONE AREA

### **Groundwater Recharge by Diverting Surplus Water of Pond Into Well**

A pond which has become a storage pond only due to excessive silting and through which very little percolation takes place, can be utilized for recharging by this method. A bore or a well can be dug in pond when it is dry. The bore is to be drilled upto the aquifer. The top of the bore pipe is kept open above the maximum water level to allow air to escape.

In this method of recharge, first of all, a borehole of suitable diameter is drilled up to the aquifer layer. In this borehole, pipe is fitted as shown in figure. The upper end of pipe is kept at

maximum water level and two right angle elbows are fitted at this level. At upper end one additional pipe of about one meter is fitted which will act as an air escape pipe. In order to keep pipe in position, a masonry foundation of 1.0 m × 1.0 m × 1.0 m is constructed. By this method, whenever the water surface reaches at maximum water level the surplus water will enter the pipe and reaches to aquifer. (Figs. 7.35 & 7.36).

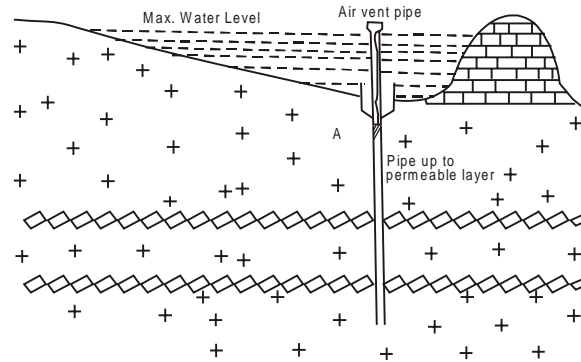

**Fig. 7.35** Groundwater recharge by diverting surplus water of pond into well.

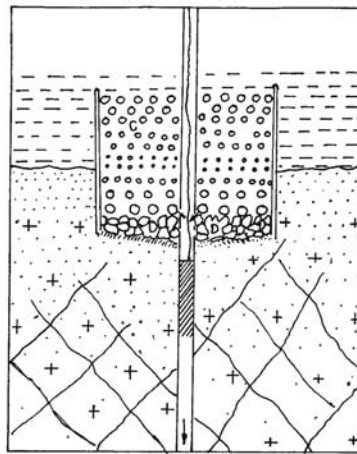

**Fig. 7.36** Details at "A".

### **Recharging Well from Nearby Stream or River**

Natural small stream or river water is first diverted into one or two small tanks provided with a filter media and then the relatively clear water is taken into the well by means of pipe. By this method open wells can be recharged, as it is possible to desilt this type of well. (Fig. 7.37).

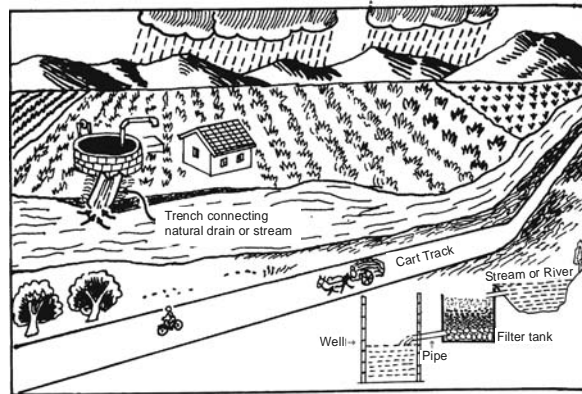

**Fig. 7.37 Recharging well from nearby stream or river.**

#### *Recharging well by constructing it in the River Bed*

When the river is dry, a series of wells can be constructed in the river bed with a filter media and air vent pipe is provided to allow air to escape. During monsoon, the wells will pour large quantity of water into the ground (Refer Fig. 23).

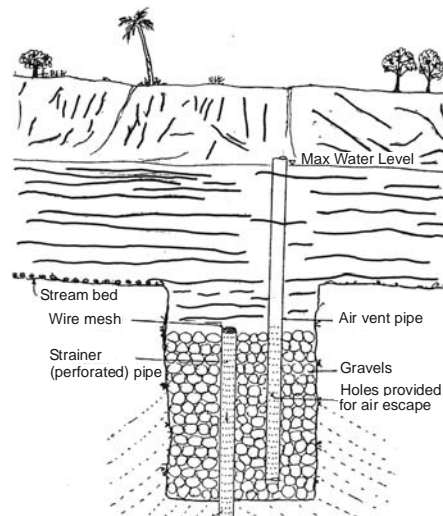

**Fig. 7.38 Recharging well by constructing it in the river bed.**

#### *Recharge by Excavating Soak Trenches in The River Bed*

In this method of recharge soak trenches of 3.0 m diameter and 3.0 m depth with filter media are constructed at several distance apart in the river bed as shown in the Fig. 7.39. In each soak trench, borehole of 10 to 15 cm diameter is drilled up to aquifer. Necessary strainer pipe and filter medium are to be provided as shown in the Fig. 7.39.

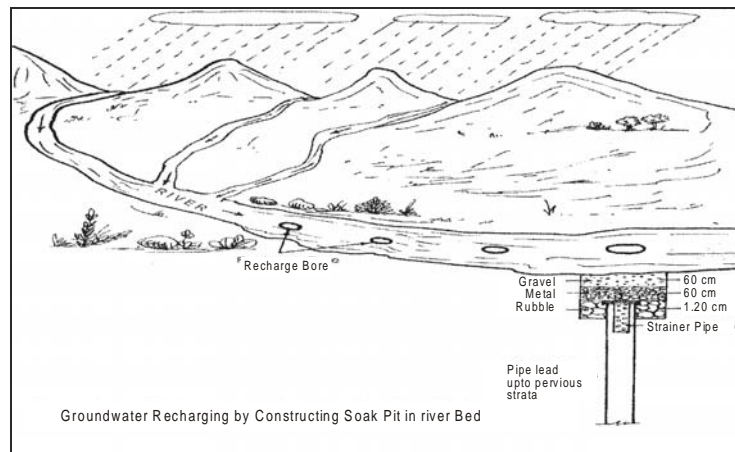

Fig. 7.39 Soak trenches in the riverbed.

### Recharging of Tube Well by Syphonic Action

When the riverbed level near the vicinity of tube well is relatively lower, then the tube well can be recharged by Syphonic action. As shown in the figure, first close the outlet of the delivery pipe and then connect the delivery pipe by a syphon pipe upto the river. Now start the pump so that water will flow from the tube to the river and then stop the pump. The reverse flow will start due to Syphonic action and filtered river water will flow into the well (Fig. 7.40).

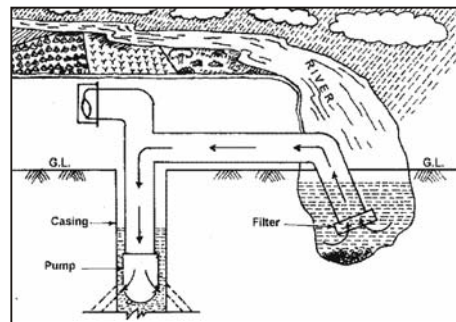

Fig. 7.40 Recharging of tube well by syphonic action.

### Hydraulics of Injection Wells

For new wells, without clogging, the injection head only depends on the capacity and the geohydrological situation and can easily be calculated with the formulae and assumptions already made:

- all recharge wells have the same water level, at a distance  $S_0$  above the original horizontal groundwater table;
- by the use of well pumps with a steep characteristics, all recovery wells have the same capacity.



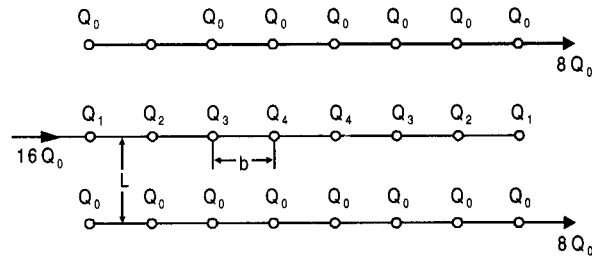

Fig. 7.41 Recharge scheme with wells.

These assumptions are shown in Fig. 7.41. Supposing, moreover, an artesian aquifer without recharge, the value of  $S_0$  for the outer injection well with capacity  $Q_1$  is given by

$$S_0 = \frac{Q_1}{2\pi kH} \ln\left(\frac{R}{r_0} \frac{R}{7b}\right) + \frac{Q_2}{2\pi kH} \ln\left(\frac{R}{b} \frac{R}{6b}\right) + \frac{Q_3}{2\pi kH} \ln\left(\frac{R}{2b} \frac{R}{5b}\right) + \frac{Q_4}{2\pi kH} \ln\left(\frac{R}{3b} \frac{R}{4b}\right) - \frac{Q_0}{2\pi kH} \ln\left(\frac{R^2}{L^2} \frac{R^2}{L^2 + (7b)^2} \frac{R^2}{L^2 + (6b)^2} \frac{R^2}{L^2 + (2b)^2} \times \frac{R^2}{L^2 + (5b)^2} \frac{R^2}{L^2 + (3b)^2} \frac{R^2}{L^2 + (4b)^2}\right)$$

With the total amount of recharge equal to the total amount of recovery, the value of  $R$  disappears from this equation. Stated otherwise,  $R$  may be replaced by a random value, for instance,  $R = 10b$ . Assuming, moreover,  $L = 2b$  and  $r_0 = b/200$ , then, for the outer abstraction wells,

$$S_0 = \frac{Q_1}{2\pi kH} (7.9576) + \frac{Q_2}{2\pi kH} (2.8134) + \frac{Q_3}{2\pi kH} (2.3026) + \frac{Q_4}{2\pi kH} (2.1203) - \frac{Q_0}{2\pi kH} (15.1790),$$

and similar formulae for the value of  $S_0$  at the injection wells with capacity  $Q_2$ ,  $Q_3$  and  $Q_4$ . Subtracting from  $S_0$  at wells 1, 2 and 3 the value of  $S_0$  at well 4 gives, after rearranging terms,

$$\begin{aligned} 5.8373Q_1/Q_0 + 0.0000Q_2/Q_0 - 1.6094Q_3/Q_0 - 7.7832Q_4/Q_0 &= -4.7727 \\ 0.6931Q_1/Q_0 + 5.4806Q_2/Q_0 - 0.6931Q_3/Q_0 - 7.0901Q_4/Q_0 &= -2.4118 \\ 0.1823Q_1/Q_0 + 0.4055Q_2/Q_0 + 4.8929Q_3/Q_0 - 5.9915Q_4/Q_0 &= -0.8024 \end{aligned}$$

Together with

$$Q_1/Q_0 + Q_2/Q_0 + Q_3/Q_0 + Q_4/Q_0 = 8$$

This means four linear equations with four unknowns and the results are:  $Q_1 = 2.2321Q_0$ ;  $Q_2 = 1.9676Q_0$ ;  $Q_3 = 1.9076Q_0$ ;  $Q_4 = 1.8928Q_0$ ;  $S_0 = 16.5245Q_0/(2\pi kH)$

With an average flow rate of  $Q_0/b$  while  $L = 2b$ , the head increases would be

$$S_0' = \frac{Q_0}{b} \frac{L}{kH} = \frac{Q_0}{2\pi kH} 4\pi$$

Because of the influence of finite length, this value must be divided by  $\alpha_2$ . With  $B/L = 4$ ,  $\alpha_2 = 1.17$ . This result, however, must still be augmented by the influence of point injection; while noting that  $Q_{inj} = 2Q_0$ ,

$$\Delta S_0' = \frac{2Q_0}{2\pi kH} \ln\left(\frac{b}{2\pi r_0}\right), \text{ and with } r_0 = b/200,$$

$$\Delta S_0' = 6.9209 Q_0/(2\pi kH)$$

Together  $S_0 = (S_0'/\alpha_2) + \Delta S_0' = 17.6613 Q_0/(2\pi kH)$  or 7% above the correct value.

According to the calculations given above, the capacity of the outer injection wells is 12% above and of the inner wells 5% below the average value. These differences are higher when the ratio  $L/b$  increases. For  $L = 4b$  and a more or less square recharge scheme, they amount to +20% and -11%. When, during operation, clogging of the injection wells occurs, these differences will decrease.

Increasing the injection head to overcome the clogging of the formation surrounding the well screen has little influence on the cost of operation, but it may result in soil cracks through which the recharge water flows upward to the ground surface. To investigate this danger, Fig. 7.42 shows the pressure distribution in the sub-soil before and during injection. From soil mechanics, it is known that the vertical grain pressure equals the difference between the soil pressure and water pressure:

$$\sigma_g = \sigma_s - \sigma_w$$

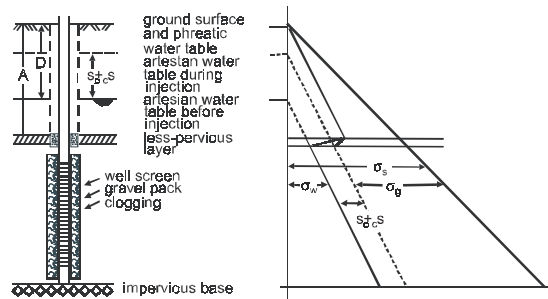

Fig. 7.42 Pressure distribution in sub-soil.

Using the notation of Fig. 7.42, the smallest grain pressure occurring at the top of the artesian aquifer equals, before injection,

$$\sigma_g = \rho_s gA - \rho_w g (A - D), \text{ with } \rho_s \text{ and } \rho_w \text{ as the mass densities of soil and water, respectively.}$$

The horizontal grain pressure normal to the vertical planes is smaller by a factor  $\alpha$

$$\sigma_{gh} = \alpha \sigma_g$$

and will, during injection, decrease by an amount  $\rho_w g (S_0 + S_c)$ , where  $S_c$  is the increase of the injection pressure,  $S_0$ , by clogging. Together these give

$$\sigma_{gh} = \alpha \rho_s gA - a \rho_w g (A - D) - \rho_w g (S_0 + S_c)$$

To prevent vertical cracks from developing, this pressure must be larger than zero or  $S_0 + S_c < \alpha \frac{\rho_s}{\rho_w} A (A - D)$  the real value of  $\alpha$  is impossible to determine, but according to theory its minimum value equals (neglecting cohesion)

$$\alpha = \tan^2 \left( 45 - \frac{\phi}{2} \right)$$

with  $\phi$  as the angle of internal friction. For sand, this angle varies between  $30^\circ$  and  $40^\circ$ , thus  $\alpha = 0.33$  to  $0.22$ . Using the lowest value and assuming for water saturated sand  $\rho_s = 2\rho_w$ , one finally gets

$$S_0 + S_c < 0.22 (A + D)$$

Meaning that for  $D = 0$ , the water level inside the well may not rise more than  $0.22A$  above the ground surface or with, for instance,  $A = 20$  m, not more than  $4.4$  m above the

ground surface. In the example given above,  $S_0 = \frac{Q_0}{2\pi kH}$  (16.5)

Assuming  $Q_0 = 0.02$  m<sup>3</sup>/s and  $kH = 0.03$  m<sup>2</sup>/s, then  $S_0 = 1.75$  m, giving for the rise,  $S_c$ , in the injection head due to clogging  $S_c = 4.4 - 1.75 = 2.65$  m, which is a rather small value.

The changes in the injection head may also be caused by variations in the temperature,  $T_r$ , of the recharge water. In temperature climates,  $T_r = T_0 + T_c \sin(\omega t)$  which variations propagate through the aquifer with little damping but a large delay. Neglecting this damping altogether, it gives for the temperature at a distance  $x$  down stream of the line of recharge wells

$$T_x = T_0 + T_c \sin(\omega t - \delta x)$$

The average temperature over the flow length  $L$ , thus becomes

$$T_a = \frac{1}{L} \int_0^L T_x dx = T_0 + [2/\delta L] \sin\left(\frac{1}{2}\delta L T_c\right) \sin\left(\omega t - \frac{1}{2}\delta L\right)$$

$$\text{with } \delta L = \frac{\rho_a C_a}{\rho_w C_w} \frac{\omega T_d}{P}$$

For sandy aquifers

$$\delta L = 1.8 \omega T_d \text{ and } T_d = 60 \text{ days, } \delta L = 1.8 \times \frac{2\pi}{365} \times 60 = 1.86, \text{ and } [2/(\delta L)] \sin\left(\frac{1}{2}\delta L\right) = (2/1.86) \sin(1.86/2) = 0.86$$

With  $T_0 = 12^\circ\text{C}$  and  $T_c = 10^\circ\text{C}$ , the average temperature of the water in the recharge area thus varies from  $12^\circ - 8.6^\circ = 3.4^\circ\text{C}$  to  $12^\circ + 8.6^\circ = 20.6^\circ\text{C}$ , causing variation in the kinematic

viscosity and the injection head by a factor  $\left(\frac{20.6 + 42.5}{3.4 + 42.5}\right)^{1.5} = 1.61$

When the maximum allowable injection head is 4.4 m, the value in autumn may thus not rise above 2.7 m, a serious reduction indeed.

### **Recharging of Hand Pump by Roof or Terraced Water**

The water from the terrace or roofs of the houses are collected into small masonry tank under ground and is taken into the casing pipe of the tubewell or hand pump as shown in the figure. In this method, first of all rainwater is collected in masonry tank of size 1.0 m × 1.0 m × 1.0 m depth provided with baffle walls (stabilization tank) to have primary removal of waste materials. Pipe connecting stabilization tank to casing pipe of hand pump is fitted. Allow first rainwater to drain off out side by means of two valves arrangement as shown in Fig. 7.43.

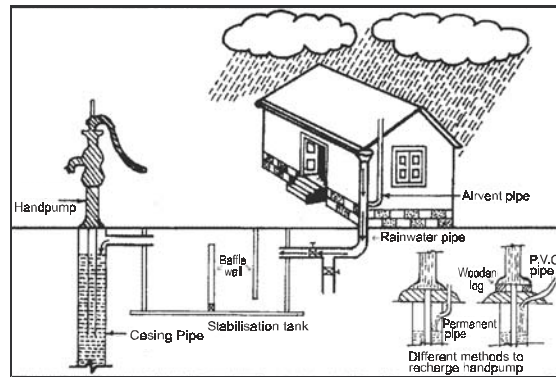

**Fig. 7.43 Recharging of hand pump by roof or terraced water.**

### **Excavating Soak Trenches at the End of Farm Slope (Fig. 7.44)**

Soak trenches filled with filter media can be constructed at the end of farm slope so that rainwater as well as excess water due to flood irrigation is collected into it. By doing this, not only that groundwater will be recharged but also moisture in the root zone will be maintained. This will be much more useful when there is a gap between two rains.

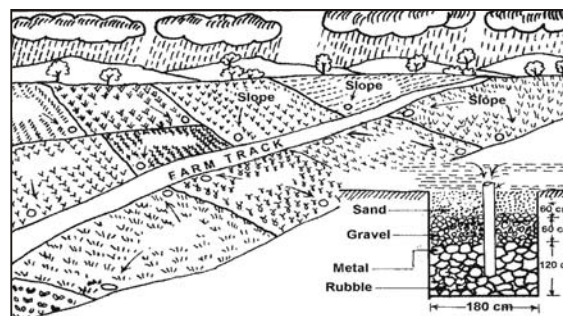

**Fig. 7.44 Excavating soak trenches at the end of farm slope.**

### Constructing Farm Ponds

During monsoon, the surface runoff takes place in the farms. Looking to the direction of flow, a suitable pond can be constructed in the farm, which will serve as storage as well as percolation pond. Till water is available at surface, it can be pumped directly and later on it can be available by lifting. (Fig. 7.45).

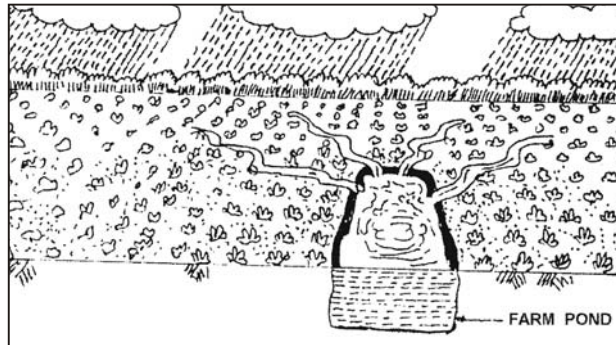

Fig. 7.45 By constructing farm ponds.

### Constructing Hidden Weir in the River Bed

When the river is dry, remove the sand from the riverbed and create a barrier of clay filled plastic bags. Cover this barrier by L.D.P.E. plastic sheet and 30 cm thick fine clay layer as shown in the figure. Backfill the excavated sand in the trench. This barrier will reduce the flow below the bed level and increase time of percolation. Such a weir can be constructed at approximate 1 km distance from each other throughout the stream. (Fig. 7.46).

### Constructing Soak Channel on Downstream Side of Farm

On downstream side slope of the farm excavate one channel of size 2.0 m × 2.0 m × 2.0 m depth. In this channel, first of all fill the pebbles of 5 to 10 cm size up to 1.0 m depth and remaining 1m depth with gravels and sand as shown in the figure. By this method rainwater will be percolated in the subsurface. (Fig. 7.47).

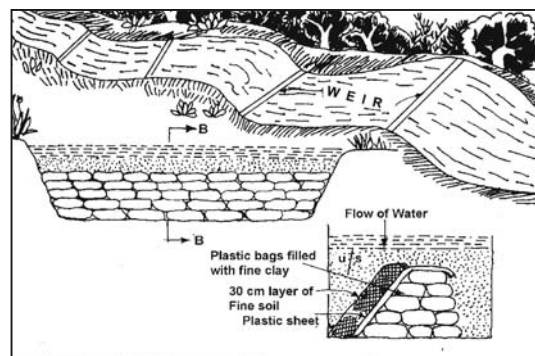

Fig. 7.46 By constructing hidden weir in the river bed.

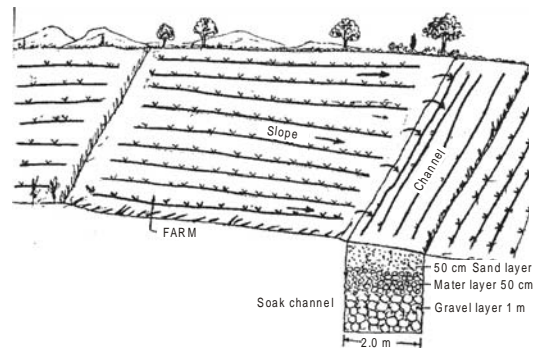

Fig. 7.47 By constructing soak channel on downstream side of farm.

## 7.12 WELL CLOGGING MECHANISM AND THEIR PREVENTION

According to experience gained all over the world, the main causes for the clogging of injection wells are:

- the presence of air bubbles in the recharge water;
- the presence of suspended matter in the recharge water;
- the growth of bacteria in the gravel pack and surrounding formation;
- reactions between the recharge water on one hand and, on one other hand, the native groundwater and aquifer material present in the formation;
- mechanical jamming.

These causes, their identification and prevention when possible will be discussed in the next paragraphs. Identification is greatly facilitated by the installation of piezometers as shown in Fig. 7.48, one at the outer circumference of the gravel pack and others at distances of, say, 2 and 5 m from the well center. At any moment, these piezometers show where clogging has taken place, while the rise of water level with time gives valuable information about the nature of the clogging matter. Needless to say that, for this purpose, the changes in water level accompanying variations in capacity and temperature should first be eliminated.

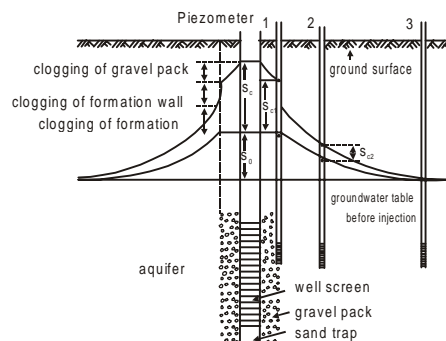

Fig. 7.48 Installation of piezometers for the identification of injection well clogging.

**Presence of air bubbles:** During injection, air bubbles may be entrained by the free fall of the water when the injection pipe ends some distance above the water level in the well casing and may come out of solution when the water pressure drops below atmospheric. In water at rest, air bubbles with diameters between 0.1 and 10 mm rise at velocities of 0.3 – 0.4 m/s, meaning that injection with higher flow rates carries them downward, through the well screen openings into the gravel pack and surrounding formation. Here, they clog the pores between the individual grains, causing an additional resistance, which in its turn decreases the injection capacity and the amount of air supplied. On the other hand, the air bubbles present will dissolve into the water flowing by, together meaning that already after a short time an equilibrium situation is brought about and no further increase in injection head occurs (Fig. 7.49). The entrainment of air can easily be prevented by carrying the supply to some distance below the static water level in the well. In the upper part of this pipe, water pressures below atmospheric would still occur, unless at the lower end an orifice is installed, giving such a flow resistance that everywhere a water pressure 1 – 2 m positive is maintained. With the pressure diagram of Fig. 7.50, this flow resistance can easily be calculated.

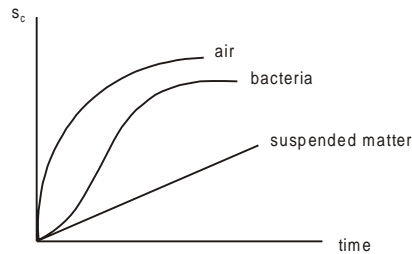

Fig. 7.49 Increase of injection head with time.

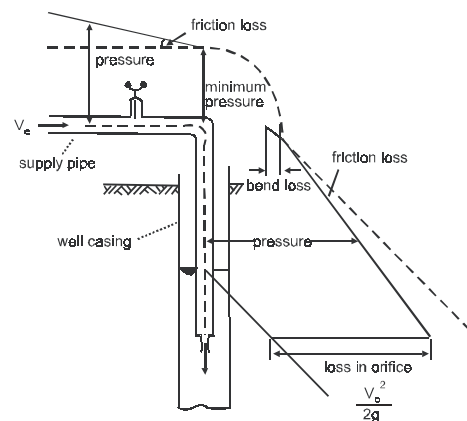

Fig. 7.50 Water pressure during injection.

When the valve in the supply pipe of Fig. 7.50 is used to reduce the capacity of this particular well, it should be realized, however, that an additional lowering of the pressure would occur.

The solubility of air in water decreases with rising temperature, meaning that air bubbles will also evolve when cold recharge water is mixed with warm groundwater. For a temperature increase of 10° C, the solubility decreases by a factor 0.8. This can be compensated, however, by a pressure increase from 1 to 1.25 atm, so that no difficulties will arise when the top of the well screen is more than 2.5 m below the water level in the well. This is always the case.

As already mentioned, clogging by air bubbles is easily recognized by a sharp increase in the injection head directly after recharge operations starts, reaching its maximum value already after some hours (Fig. 7.49). When the operation is stopped, the water in the well will, moreover, foam due to escaping air bubbles.

**Presence of suspended matter:** Clogging by suspended matter manifests itself by an increase in the injection head,  $S_c$ , which, for a particular well and recharge water, grows linearly with time (Fig. 7.49), while it is proportional to the square of the capacity. This can easily be explained by assuming cake filtration to occur, the cake having a constant coefficient of permeability,  $k'$ , while its thickness,  $t$ , increases by the deposition of suspended matter present in a gravimetric concentration,  $c$ , in the recharge water. For a fully penetrating well in an aquifer of depth  $H$ , this gives with the notation of Fig. 7.51.

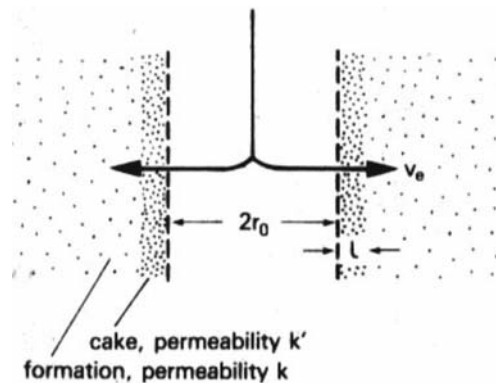

Fig. 7.51 Injection well clogging.

$$\text{Darcy} - S_c = \frac{Q_0}{2pk'H} \ln\left(\frac{r_0+1}{r_0}\right) - \frac{Q_0}{2\pi kH} \ln\left(\frac{r_0+1}{r_0}\right) = \frac{Q_0(k-k')}{2\pi k k'H} \ln\left(\frac{r_0+1}{r_0}\right)$$

$$\text{Continuity} - Q_0 \frac{c}{\rho_d} dt = 2\pi(r_0+1)Hdl(p-p'), \text{ where } \rho_d \text{ is the mass density of the deposits}$$

and  $(p - p')$  the decrease in pore space. Integration between the limits  $t = 0, l = 0$  and  $t = t, l = l$  gives, after rearranging terms,



$$\left(\frac{r_0 + l}{r_0}\right)^2 = 1 + \frac{Q_0 ct}{\pi(p-p')Hr_0^2 \rho_d}$$

By substitution

$$S_c = \frac{Q_0(k-k')}{4\pi k k' H} \ln \left[ 1 + \frac{Q_0 ct}{\pi(p-p')Hr_0^2 \rho_d} \right]$$

This looks rather complicated, but with  $l \ll r_0$ , it reduces to

$$\ln \left(\frac{r_0 + l}{r_0}\right) = \left(1 + \frac{l}{r_0}\right) \approx \frac{l}{r_0}$$

Therefore, after substitution,

$$S_c = \frac{k-k'}{k k' (p-p') \rho_d} \frac{Q_0^2 ct}{4 p^2 r_0^2 H^2}$$

Assuming that  $p'$  and thus  $k'/k$  has some minimum values,  $S_c$  may be simplified to  $S_c = \alpha [Q_0^2 ct / (4\pi^2 r_0^2 H^2)]$ , where  $\alpha$  is a constant.

With the entrance rate

$$v_e = Q_0 / 2 \pi r_0 H$$

this may be further simplified to

$$S_c = \alpha v_e^2 ct$$

once the value of  $\alpha$  has been determined for an existing well, operating with a particular recharge water, the clogging rate for the other wells in the same formation using the same recharge water, but having a different capacity, diameter or depth of penetration, can easily be calculated. The results, however, cannot be used for other aquifers or other types of recharge water as now the values of  $k'$ ,  $p'$ ,  $\rho_d$  and thus  $\alpha$  are changed in an unknown way. Even the influence of the concentration,  $c$ , of suspended particles in the same recharge water is less straightforward than would follow from the formula given above. Cases are known where  $c$  was drastically reduced by pre-treatment, using chemical coagulation, flocculation, settling and filtration, without a noticeable change in the clogging rate. Afterwards, this has been explained by considering the untreated water to contain negatively charged particles, which are difficult to retain by the negatively charged sand grains in the formation, leading to deep-bed filtration and a low clogging rate. After treatment, the remaining particles had a positive charge and were easily captured by the negatively charged sand grains, resulting in cake filtration and, notwithstanding the much smaller amount, in about the same rate of clogging. The pre-treatment, incidentally, still had advantages as the small amount of penetration allowed a more rapid and more complete removal of the clogging by cleaning. To evaluate the influence

of pretreatment, only tests in situ can give reliable results, while filtration tests in the laboratory are only a poor substitute.

Another problem is that for waters with a low suspended matter content, drinking water for instance, there is no relation between turbidity and clogging rate, making evaluation of field tests rather difficult. More meaningful results in this respect can be obtained with membrane filter test, whereby the water to be investigated is filtered at a constant head (2 atm) and a constant temperature (10° C) through a membrane with a specified diameter (42 mm), having very fine openings (0.45 μm). With the notation of Fig. 7.52.

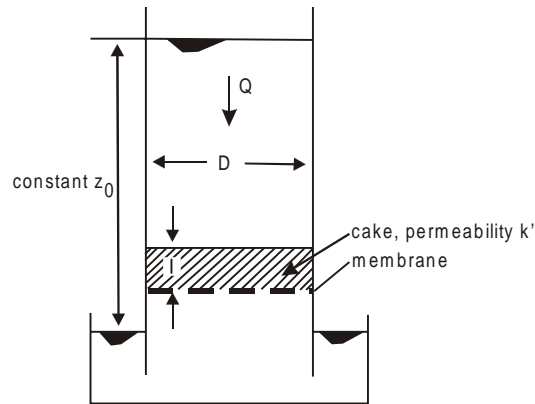

**Fig. 7.52 Membrane – filter test.**

$$\text{Darcy} - z_0 = z_{\text{membrane}} + z_{\text{cake}}$$

$$z_0 = \frac{Q}{\frac{1}{4} \pi D^2} \left( \beta + \frac{1}{k'} \right) \text{ or } Q = \left( \frac{z_0}{\left( \beta + \frac{1}{k'} \right)} \right) \frac{\pi D^2}{4}$$

$$\text{continuity } Q \frac{c}{\rho_d} dt = \frac{1}{4} \pi D^2 dl$$

and with the value of Q given above

$$dt = \frac{\rho_d}{c z_0} \left( \beta + \frac{1}{k'} \right) dl$$

integration between the limits  $t = 0, l = 0$  and  $t = t, l = l$  gives

$$t = \frac{\rho_d}{c z_0} \frac{k'}{2} \left[ \left( \beta + \frac{1}{k'} \right)^2 - \beta^2 \right]$$

from which follows

$$\beta + 1/k' = \sqrt{[2cz_0t/(\rho_d k')] + \beta^2}$$

and 
$$Q_0 = \frac{z}{\sqrt{[2cz_0t/(\rho_d k')] + \beta^2}} \frac{\pi}{4} D^2$$

The total amount of water filtered since the start of the test equals

$$V = \int_0^t Q_0 dt = \frac{\rho_d k'}{c} \left\{ \sqrt{[2cz_0t/(\rho_d k')] + \beta^2} - \beta \right\} \frac{\pi}{4} D^2$$

or

$$t = \frac{c}{2\rho_d k' z_0} \frac{V^2}{\left(\frac{1}{4}\pi D^2\right)^2} + \frac{\beta V}{z_0 \frac{1}{4}\pi D^2}$$

and 
$$\frac{t}{V} = \gamma V + \epsilon$$

with  $\epsilon$  constant and  $\gamma$  depending on the clogging properties of the water investigated ( $c$ ,  $\rho_d$  and  $k'$ ).  $\gamma$  is called the membrane filter index (MFI), is expressed in seconds per liter square and is calculated as the slope of the graph obtained by plotting  $t/V$  against  $V$  on a linear scale (Fig. 7.53). This MFI is a much better yardstick than the turbidity (Fig. 7.54) and although not completely reliable, it gives fair indication of the danger of well clogging by suspended matter. As an example, Fig. 7.55 shows the normalized clogging rate as a function of the MFI for various wells in the Pleistocene sands along the Dutch North Sea coast using different types of water.

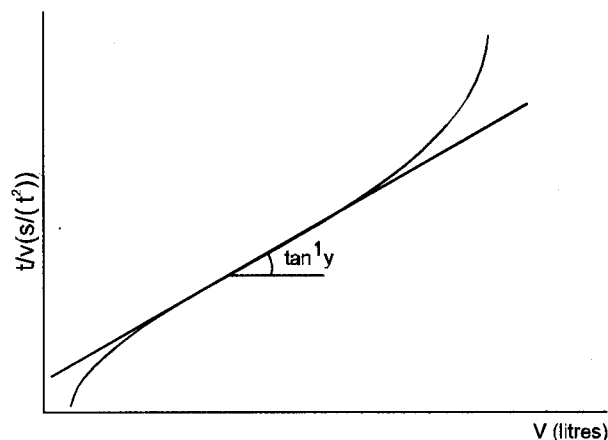

Fig. 7.53 Membrane filter test results.

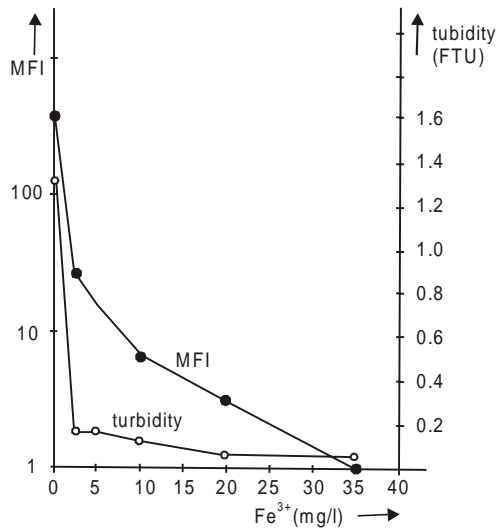

Fig. 7.54 Decrease of turbidity and MFI by rapid filtration as a function of the iron dose.

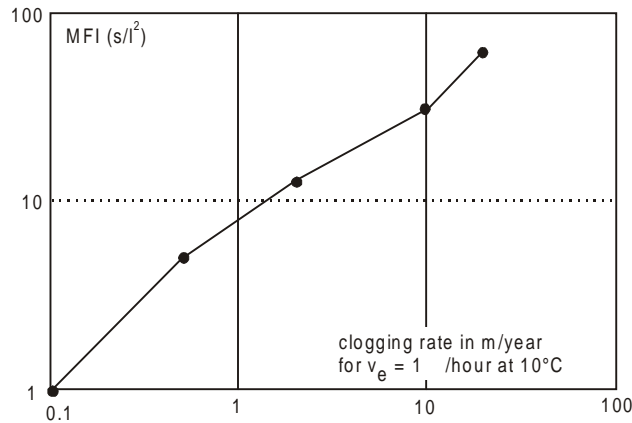

Fig. 7.55 Relation between clogging rate and membrane filter index.

During well injection, the physical and chemical environment of the recharge water changes, by which dissolved impurities may be transformed into suspended ones. Small amounts of iron and manganese present in any recharge water may fall out by contact flocculation or may be precipitated, together with carbonates, by changes in pH and redox potential, again resulting in clogging by suspended impurities. The removal of clogging by suspended matter can easily be obtained by well cleaning, but it is seldom 100% effective.

**Growth of bacteria:** Bacteria are also suspended matter, but their combined volume is extremely small. With, for instance, 100 bacteria/cm<sup>3</sup>, each with a volume of 2 μm<sup>3</sup>, the suspended matter content of the recharge water equals 0.2 parts per billion, from which no clogging needs to be feared. Bacteria, however, are living things and multiply rapidly. In time  $t$ , their number grows from  $n_0$  to  $n$  according to

$$n = n_0 e^{0.693t/T_d}$$

with  $T_d$  as the doubling time. With an entrance velocity  $v_e$ , the number passing the wall of the borehole in time  $dt$  equals

$$dN = v_e n_0 dt$$

In time  $t$ , this number increases to

$$dN = v_e n_0 e^{0.693t/T_d} dt$$

giving at a time  $T$  after injection starts

$$N = \int_0^T v_e n_0 e^{0.693t/T_d} dt = v_e n_0 \frac{T_d}{0.693} (e^{0.693T/T_d} - 1)$$

Assuming  $v_e = 1$  m/hour = 24 m/day,  $n_0 = 100/\text{cm}^3 = 10^8/\text{m}^3$ ,  $T_d = 0.3$  day, then after  $T = 1$ , week = 7 days

$$N = 24 \times 10^8 \times \frac{0.3}{0.693} e^{0.693 \times 7 / 0.3} = 1.1 \times 10^{16}$$

With a volume of  $2 (\mu\text{m})^3 = 2 \times 10^{-18} \text{ m}^3$  each and a porosity of 45 %, this means a layer with a thickness

$$l = \frac{1.1 \times 10^{16} \times 2 \times 10^{-18}}{0.55} = 4 \times 10^{-2} \text{ m} = 4 \text{ cm}$$

after some time completely sealing the wall of the borehole. Real situations in the meanwhile are less dramatic, as the calculations given above pre-suppose an unlimited food supply. This food, however, is only present in small amounts in the recharge water, meaning that already after short time equilibrium situation arises, where the available food is used to maintain the population at a constant number (endogenic respiration) and no further growth occurs. During this endogenic phase, bacteria need about 0.03 kg *BOD* per day and per kg of dry matter conforming to a volume of roughly 10 l. With an entrance rate of 1 m/h and recharge water with a *BOD* of 5 mg/l the food supply equals 0.120 kg *BOD*  $\text{m}^2 \text{ day}^{-1}$ , which is able to maintain indefinitely a 40 mm thick layer of bacteria.

From the description given above, it will be clear that the rise,  $S_c$ , in the injection head due to bacterial clogging reaches its maximum value already after some days (Fig. 7.49). When large amounts of biodegradable matter are present in the injection water, a complete sealing of the well may occur within 1 or 2 weeks. Bacteria preferably grow where their food supply is most abundant, that is, in the well screen openings and the gravel pack when present and here the resistance will be concentrated (Fig. 7.48). Growth of bacteria can be prevented in two ways: (i) by removing their food prior to injection, for instance, by a preceding slow sand filtration; (ii) by killing the bacteria with chlorine, maintaining inside the well a residual of 1 – 2 ppm.

Clogging caused by bacteria can easily be removed by burning them away with chlorine. Some operators prefer to do this once or twice a year instead of the continuous chlorination

mentioned above under (ii). Bacterial clogging disappears by it when the well is taken out of service and the food supply stops. The ensuing putrefaction, however, may impart a horrible taste to the water present in the formation.

**Reactions involving the recharge water:** For completeness, it may be recalled that reactions between the two types of water can only occur at the start of the injection process, at the interface between the recharge water and the displaced native groundwater. In fine-grained formations, this mixing zone is narrow and no adverse effects need to be feared. In coarse grained and fissured rock formations, an appreciable amount of mixing may take place, but here the openings are so large that the reduction in permeability by the deposits formed is again small. The most important reaction follows the mixing of anaerobic groundwater containing ferrous iron with aerobic recharge water, producing insoluble ferric oxide hydrates. To be doubly safe, the recharge operations proper could be preceded by an injection of anaerobic water, pushing the zone of possible reactions to such a distance away from the well that the increase,  $S_c$ , in the injection head is always negligible.

The adverse effects between the recharge water and the aquifer material mainly concern the swelling and dispersion of clay particles, present as silt in the formation. This clay consists of small negatively charged threads, plates or flocs, kept together by positively charged ions, in particular, by those having a multiple charge. In aquifers containing fresh water, the swelling of clay particles and the reduction of pore space occur when the ratio between  $Ca^{2+} + Mg^{+}$  and  $Na^{+} + K^{+}$  is reduced and/or the ionic strength is lowered. This can probably be prevented by choosing another type of recharge water or by adding  $CaCl_2$  to the recharge water. It may further be reduced by a pre-flush with water containing high amounts of  $CaCl_2$ . When fresh water is injected into a saline aquifer, the processes of mixing and cationic exchange produce a zone of advancing water with the low ionic strength of fresh water and the high SAR value of saline water. This combination strongly reduces electrostatic bonding and produces the swelling and dispersion of clay particles when present. The dispersed clay particles are entrained by the flowing water over considerable distances, but sooner or later they are captured in the converging spaces between adjoining sand grains, thus decreasing pore space and permeability. Flushing with  $CaCl_2$  to increase the bonding strength is again a preventing measure, but it is not always effective. Polyvalent metal ions give better results, but they may not be applied in drinking water practice.

The cleaning of wells clogged by the swelling and dispersion of clay particles in the surrounding aquifer has only very limited effects.

**Mechanical jamming:** With a dual-purpose well, the direction of flow reverses periodically, which might lead to a decrease in pore space, lowering the permeability of the formation in the immediate vicinity of the well (mechanical jamming). The influence on the rise  $S_c$  in the injection head can be calculated in the same way as indicated below:

$$S_c = \frac{Q_0(k - k')}{2\pi k k' H} \ln \left\{ \frac{r_0 + l}{r_0} \right\}$$

With, for instance,  $Q_0 = 10 \times 10^{-3} \text{ m}^3/\text{s}$ ,  $k = 0.3 \times 10^{-3} \text{ m/s}$ ,  $k' = 0.7 k$ ,  $H = 30 \text{ m}$ ,  $r_0 = 0.3 \text{ m}$ , then

$l(\text{m})$	0.5	1.0	2.0
$S_c(\text{m})$	0.08	0.11	0.16

meaning that adverse effects are small.

Summing up, it may be said that injection well clogging by air bubbles and bacteria can easily be prevented, while clogging due to mechanical jamming is rare and its influence on the rise,  $S_c$ , in the injection head always small. Clogging due to the interaction between the recharge water and the aquifer material can only partially be prevented by the addition of chemicals, which may adversely affect the quality of the artificial groundwater recovered. Looking for another site or another quality of recharge water may now be a better proposition. Clogging by suspended matter can be prevented to a large degree by pre-treatment, but this may involve high costs of operation. This clogging can also be removed by well cleaning and in many cases this is more economic solution.

### 7.13 CLEANING OF INJECTION WELLS

Even with good quality recharge water, injection wells clog easily and they should therefore always be designed and constructed in such a way that an effective cleaning can be obtained with simple means. In many cases, moreover, this offers a more economic solution than upgrading the pre-treatment to prevent clogging from taking place. The cleaning of injection wells can be effected in three ways: (a) at short intervals, varying from about once a day to once a month, by simple back pumping at about the same capacity as the injection rate for a period of about 0.25 h. This procedure can even be executed automatically, obviating the need for labour. (b) at long intervals, ranging from about 6 months to 5 years, using more intensive hydraulic means such as back-pumping at high rates, treating the screen section by section and, in particular, by the creation of flow reversals, (c) only when the treatment mentioned under (b) is not adequate, it may be followed by the application of chemicals to liberate, disintegrate, disperse and dissolve clogging matter. This chemical cleaning is dangerous, both for the well and for the operating personnel and should therefore only be practiced as a last resort.

**Back-pumping:** Stopping the injection and pumping the well creates a flow reversal, which first liberates the clogging material in the gravel pack and at the formation wall, and then pulls this material through the screen openings into the well and out through the pump. When clogging is due to suspended matter in the recharge water, back-pumping for 5 – 15 minutes at about the same capacity as the injection rate removes some 80 % of the increase in the injection head,  $S_c$ . Pumping for longer periods makes little sense, while increasing the capacity to 3 – 5 times the injection rate perhaps removes another 10 % of  $S_c$ . The most attractive combination of pumping rate, pumping period and intervals between pumping varies from one well to another and should be established each time anew by field trials. Pumping should start at a low rate to prevent excessive drawdown and a collapse of the well casing and screen. Otherwise, this cleaning method is simple, hardly affects the total amount of water injected, can be done

automatically, but it requires the presence of a pump and possibility of discharging the dirty water. With dual-purpose wells, this is seldom a problem, but with single purpose wells, the installation of a submersible pump with discharge piping may be rather expensive. Notwithstanding their low efficiency, air lift-pumps, as shown in Fig. 7.56, may now be more economical proposition with the added advantage of low maintenance costs. However, pumping lowers the groundwater table and a small-saturated thickness, which are otherwise very well suited for artificial recharge. In some cases, this problem can be solved by installing a battery of, for instance, eight small-diameter recharge wells at a distance of, say, 3 m around the injection well to be cleaned.

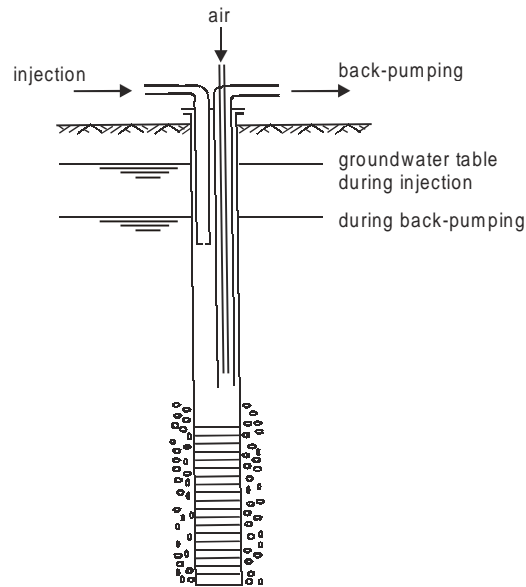

Fig. 7.56 Air lift pump for a regular cleaning of injection wells.

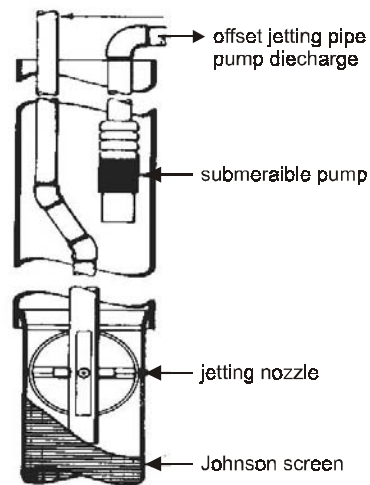
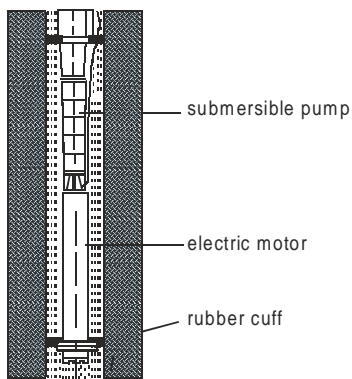

Fig. 7.57 Hydraulic cleaning of well screens.



**More intensive hydraulic methods:** When the cleaning method is not feasible or not effective in the long run, more vigorous means must be applied. Scrubbing with brushes removes deposits on the inside of a well screen and casing. Slots in the well screen may be cleaned with powerful water jets directed horizontally outward, as shown in Fig. 7.57. These jets also agitate and clean the inside of the gravel pack, while a submersible pump removes the liberated clogging simultaneously. To clean the outside of the gravel pack and the formation wall, large values of the entrance velocity,  $v_e$ , are necessary, which can be obtained by treating the screen section by section, for instance as shown in Fig. 7.58. This is particularly effective when the gravel pack has been clogged by, for instance, bacterial growth or iron deposits, but due to short circuiting (Fig. 7.59) it is of less help to remove clogging at the formation wall.

These clogging, mainly originating from suspended solids in the recharge water, cling tenaciously to the grains of the formation and are very difficult to dislodge. Straight pumping, even at high entrance rates, has often little effect and the best way to liberate them is the creation of flow reversals. Once they are free, they can easily be pulled through the gravel pack and screen openings into the well and out through the pump. Flow reversals can be affected in different ways, but in the case under consideration the use of compressed air, as shown in Fig. 7.60, is most simple and effective. The operation starts with the air cock open and the three-way valve turned so as to deliver air down the air line. The combination of drop pipe and inside airline operates as a regular air lift pump, abstracting water from the well and out through the discharge pipe. After the water has become clear, free of suspended matter, the supply of air is cut off and the water in the well is allowed to regain its static level.



**Fig. 7.58** Cleaning a well Section by suction.

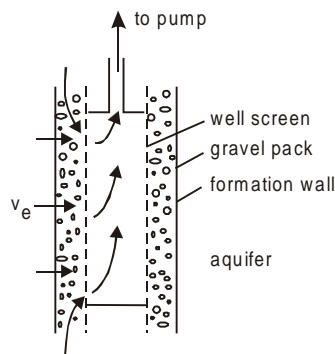

**Fig. 7.59** Short-circuiting during sectional cleaning.

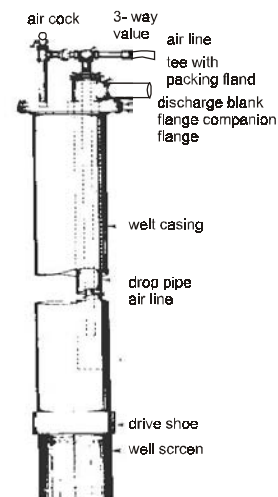

**Fig. 7.60** Cleaning of injection wells using air.

The air cock is now closed and the three way valve is turned so that the air supply is directed down the bye pass to the top of the well. This air forces the water out of the casing

and back through the screen openings into the formation, agitating the sand and loosening the clogging. After the water level has been lowered to the bottom of the drop pipe, the air will escape upward through this pipe, without the danger of air clogging the formation. The air cock is now opened, allowing a rapid rise of the water level in the well and inflow of groundwater at high velocities. This inflow is further promoted by directing the air supply down the airline to pump the well. The procedure is repeated several times, until the pumped water has become clear and no more debris can be drawn into the well. Sometimes it is necessary to remove the washed-in material by boiling, to keep the well screen active over its full length. From the description given above, it will be clear that hydraulic cleaning is a rather complicated operation, taking 1-2 days to perform. Keeping injection wells operable in this way is therefore only an acceptable proposition when the intervals between cleaning are long, e.g. more than one year.

**Chemical cleaning:** In some cases, the clogging material is so strongly attached to the grains of the gravel pack and surrounding formation, that the shear stresses created by hydraulic cleaning are inadequate to dislodge them. The surging described above must now be preceded by chemical treatment of which the most important are: (1) Chlorine or chlorine compounds, such as sodium hypochlorite ( $\text{NaOCl}$ ) or calcium hypochlorite [ $\text{Ca}(\text{OCl})_2$ ], to burn away deposits of bacterial slimes. Moreover, they kill the bacteria present and when the distance over which this occurs is large, subsequent growth of bacteria is greatly retarded. (2) Acids, such as hydrochloric acid ( $\text{HCl}$ ), sulphuric acid ( $\text{H}_2\text{SO}_4$ ) or sulphamic acid ( $\text{NH}_2\text{SO}_3\text{H}$ ), to dissolve deposits of calcium carbonate, magnesium hydroxide and iron and manganese oxide hydrates, which moreover act as cementing agents forming thick encrustations around the well screen. (3) Polyphosphates to disperse deposits of iron and manganese oxide hydrates, silt and clay particles.

**This page  
intentionally left  
blank**

# 8

# CASE STUDIES

## **8.1 IN SITU WATER HARVESTING FOR DRINKING WATER SUPPLY AT CHERRAPUNJI, MEGHALAYA**

Cherrapunji has the dubious distinction of being one of the highest rainfall places in the world and still suffering a shortage of drinking water supply in the pre-monsoon months. The situation is prima facie paradoxical as it indicates water scarcity in the midst of super abundance of precipitation.

Cherrapunji is located on the southern fringe of the Shillong plateau, on an E-W trending escarpment at an altitude of 1310 m. Traditional water supply to the town is through the spring issuing from surrounding hills. The annual rainfall is about 11,000 mm, most of it coming in the period June to September. The local rock is limestone. These escarpments are devoid of any soil cover because of the intensity of rainfall and consequently have hardly any vegetative cover. It is claimed that the discharge from the springs has declined but no one has actually measured this. The reason for scarcity, therefore, seems to be an increase in population and per capita consumption.

Roof water harvesting, introduced by the public health engineering department of Meghalaya, comprises the collection of rainwater from house rooftops through gutters, its filtration and subsequent storage above the ground in a reservoir with an average storage of 7 cu.m. These systems are designed to supply 10 liters per capita per day for 90 days. The life span of the system is about 15 years with the costs worked out to Rs. 14,000 per cubic meter in the year 1991.

The alternative technology comprising in situ water harvesting is described here. Pits of size 10m × 10m × 10m at elevated sites close to a cluster of 10 –12 houses can be constructed. The cost of such a pit, with concrete lining, reinforced concrete roofing with inlet holes, distribution pipelines, two transient storage galvanized iron tanks etc. based on the 1990-91 rate schedule of PHED of Meghalaya, works out much cheaper than the system developed by the PHED. In addition, such situ systems are able to supply water at a rate of 40 lpcd throughout the year to an estimated population of 60 persons living in this cluster of 10 – 12 houses. This water supply will be by gravity flow as in the case of the water supply from springs. The dissolved solids and iron content will be lower than the permissible limits. It may require

chlorinating treatment for organic contamination but this also happens with water supplied by the PHED (Athavale, 2001).

Other options for improving the water supply situation for Cherrapunji town are gully plugging, creating open wells in streambeds and storing the water in abandoned limestone quarries and augmentation of spring discharge by constructing horseshoe shaped subsurface impervious barriers below the discharge point (Athavale, 1991).

## 8.2 CASE STUDIES OF ARTIFICIAL RECHARGE

### *(a) Artificial Recharge Project in Amravati and Jalgaon District of Maharashtra*

The artificial recharge project undertaken by Central Groundwater Board, central region, Nagpur, in orange growing areas of Warud, Amravati District and the banana growing areas of Jalgaon district, has demonstrated the feasibility of utilizing simple structures like percolation tanks, check dams, recharge dug wells and recharge shafts. The findings of the project in Amravati district are (1) Efficiency of the percolation tanks constructed under the project varies from 78 to 91 %, (2) Efficiency of cement plugs varies from 81.1 to 97.5 % and (3) Construction of a subsurface barrier increased the water level on the upstream of this structure by 3 m.

The findings of Jalgaon district are: (1) Efficiency of percolation tanks constructed in the project varies from 95 to 97 %, (2) Disused dug wells can be used as a recharge shaft to augment the depleted aquifers and (3) Artificial recharge through injection tube wells is feasible (Sharma et al., 1998). The experimental results prompted the local people to participate and adopt some of these methods individually. This is one of the major achievements of this project. The augmentations of groundwater through percolation tanks is a viable methodology to replenish the depleting alluvial aquifers in the districts of Dhule, Jalgaon, Akola, Buldhana and Amravati of Vidarbha region in Maharashtra.

### *(b) Artificial Recharge in Mehsana Area and Coastal Saurashtra, Gujarat*

A project on augmenting the depleted aquifers in the Mehsana area was conducted by the Central Groundwater Board. They simultaneously undertook a project on artificial recharge for controlling the saline ingress in the coastal belt of Gujarat. Both projects received assistance from the UNDP (Phadtare, 1982).

After detailed hydrogeological surveys and groundwater draft estimation, the alluvial area around Kamliwara in the Central Mehsana area was selected for pilot experiments on artificial recharge through pressure injection and surface spreading methods during 1983. The source of water drawn for the artificial recharge through pressure injection test was from the phreatic aquifer below the Saraswati riverbed. Since groundwater was used for artificial recharge, the injection water was devoid of silt and other impurities and probably chemically compatible with the water getting recharged in the aquifer. The experimental results did not show any adverse effect of clogging. The pressure injection experiment was conducted continuously for about 250 days with an average injection quantity of 225 cubic meters per day. During the recharge cycle, a rise in water level of 5 meters in the injection well and 0.6 to 1.0 m in wells 150 meters away from the injection well were observed. The higher rate of injection

continuously for about 250 days was probably sustained because of contemporaneous withdrawal from the aquifer through nearby irrigation wells.

In Mehsana area, artificial recharge experiments through the spreading method were also conducted using canal water. A spreading channel of 3.3 meters width, 400 meters in length with 1:1 side slope was constructed and the canal water was fed for 46 days. The recorded buildup in water level of 3.5 to 5.0 cm was observed up to 15 m from the recharge channel and about 20 cm at a distance of 200 m. A recharge rate of 260 cubic meters per day was estimated using an infiltration rate of 17 cm/day. Dissipation in recharge mound (1.42 in) was observed in 15 days.

Another experiment using a recharge pit (1.7 in × 1.7 in × 0.75 in) to study the feasibility of recharging the shallow aquifers was conducted at Dabhu in central Mehsana area. Canal water was used for the experiment and the pit was covered to prevent dust deposition and evaporation losses. It was reported that during the recharge phase of 60 days, the recharge was at the rate of 17.3 cubic meters per day with an infiltration of 0.5 m/day. A rise of 4.13 m in the water level was observed at a distance of 5 meters from the recharge pit. Both these recharge methods were effective in alluvial areas.

Artificial recharge through pressure injection technique was tried on a pilot scale using groundwater from a phreatic aquifer for a short period in the Mehsana alluvial aquifers. Tiwari and Srivastav (1983) have reported the results of this experiment. The source well was located in Saraswati River and the water was carried to an injection well at a distance of 130 meters by a 10 cm (diameter) pipeline. On-line flowmeter and pressure gauges were fitted to monitor the flow rate and cumulative quantity and to record the pressure developed during the injection experiment. The injection recharge experiment was conducted with 8 liters per second (lps) rate for about an hour. The injection rate was increased to 12 lps and the test was continued for 90 minutes. A drastic reduction in recharge rate (3 lps) was reported and the cause of reduction was attributed to back pressure, due to clogging of the injection well. Due to well clogging, the water level could not reach its initial static level even after eight days. Though in this case, the silt free shallow groundwater was used for recharge, the observational results clearly indicate the necessity of understanding probable clogging problems, which may arise due to many other factors apart from silt entry.

Studies on control of salinity in coastal Saurashtra using the spreading and injection methods have indicated that the recharge pit and the injection shaft can affect recharge at the rate of 192 and 2600 cubic meters per day respectively. Canal water was used for these recharge studies. It was reported that problems in land acquisition in this highly developed area make it difficult to select suitable sites for spreading structures.

The Gujarat Water Resources Development Corporation conducted pressure injection test, for a short period, in 1974 near Ahmedabad city. Processed water from the city water works was injected for 72 hours in a deep tube well and a pressure varying between 80 and 100 psi was applied with a rate of 45 liters per second.

**(c) Analysis of Two Tanks in VUDA area for Artificial Recharge**

The Vadodara Urban Development Authority (VUDA) desired to model two existing village tank by increasing capacity by desilting, increasing height of tank and provide a water weir, if necessary. It is also desired to use stored water in tank for recharging surrounding area through injection wells.

The VUDA area is formed of typically alluvial fill material of fluvial and marine origin deposited during the Quaternary period (last 1 million years) of the geological history. The alluvium is composed of alternative layers of sand and clays. The sandy layers from the aquifers yield groundwater. The thickness ratio of sand to clay in the area is approximately 1:4. The aquifers below the depth of 100m contain highly saline water (TDS above 10,000) and are not useful. The aquifers up to the depth of 100m i.e. up to blue clay horizon contain mix quality zones of fresh and brackish water (TDS 2000 – 4000). The blue clay marks the total marine origin of lower formations, while upper formations are of fluvio-marine origins. It is important to note that the aquifers to be developed have limited storage capacity and have relatively poor quality. A comprehensive summary of well inventory results of the study area is given in Table 8.1.

**Table 8.1 Summary of well inventory**

Particular	Unit	Sama		Chhani	
		OW	TW	OW	TW
Aquifer	TypeUC	SC	UC	SC	
Wells	No.4	33	-	39	
Depth	m	10-17	50-70	-	60-100
Diameter	mm	3000	150-200	-	200-250
SWL (1999)	m	8-10	15-30	20-25	-
Pump	Hp	5	5-15	-	30
Discharge	lpm	30	300-600	-	800-1500
Quality		B	B	B	B, Su
Use		D	D, I	-	D, I
Aquifer type: UC – Unconfined, SC – Semiconfined					

Quality: B – Brackish, S – Saline, Su – Sulphate

Use: D – Domestic, I – Irrigation

Three exploratory bores of 200mm diameter and 30 – 45m depths, one each on the bank of the existing village tank have been taken for the study of aquifer material, water level and quality. The bores were converted into shallow tube wells by providing blind/slotted PVC casing and gravel pack. They were used for determining permeability by pump out tests. Recharge tests were carried out by adding clean water from outside source.

The bore at Sama, drilled up to 32m depth encountered two aquifer layer; 10.5-21.0m and 16.0-30.0m depth. These have been provided with 110mm PVC slotted pipes. The top 10.5m is yellow silty soil and the two aquifers have been separated by 8m thick (18-26m depth) yellow silty clay.

The bore at Chhani encountered two aquifer zones; first, 18m thick (10-28m depth) and second, 13m thick (33-43m depth) of fine to medium sand and gravel deposit. The top soil of clay, silt and sand mixture was encountered up to 10m depth. The yellow silty clay, with kankar of 5m thickness (28-33m depth) separates the two-aquifer zones. While developing the hole, the lower 10m thick zone between 33 and -43m depth has been provided with 110mm PVC slotted pipe.

Permeability and Recharge Tests: Permeability tests for Chhani and Sama tanks were carried out by pumping water at a constant rate and measuring steady state drawdown in exploratory bores.

An observation of in-situ tests permeability tests and recharge tests are as shown in Table 8.2.

**Table 8.2 Recharge and permeability tanks**

<i>Tank</i>	<i>Recharge Rate</i>	<i>Permeability (cm/sec)</i>
Chhani	29.0 lpm at 14.8m recharge head	$4.5 \times 10^{-4}$
Sama	14.0 lpm at 3.4m recharge head	$7.12 \times 10^{-4}$

Based on topographical survey, contour maps and area capacity tables were prepared for each tank. FRL and area capacity at two tanks are given in Table 8.3.

**Table 8.3 FRL, area and capacity of tanks**

<i>Tank (m)</i>	<i>FRL</i>	<i>Area at FRL (m<sup>2</sup>)</i>	<i>Capacity at FRL (m<sup>3</sup>)</i>
Chhani	36.5	1,50,490	6,40,120
Sama	36.3	56,280	1,52,870

**Computer Modeling of Chhani Tank:** To carry out recharge study for Chhani tank area, the computer model is developed using MODFLOW software developed by US Geological Survey. The study area is discretised into a grid of 114 rows and 119 columns with variable size. Minimum spacing of 9.5m is selected in tank area and the grid spacing was increased away from tank area near constant head boundary. The aquifer is considered as confined with bottom RL as -6.0m and top RL +4.0m. It is assumed that constant head boundary exists about 800m away from tank boundary.

The results of pumping test were confirmed by model test. For a 37 lpm pumping of a well located at row -53 and column -35 and using permeability value of 4.67 m/day, the drawdown was computed by model as 1.15m as compared to observed drawdown of 1.34m. Hence permeability of 4.6 m/day is considered for recharge modeling.

Based on available water in the tank and capacity of recharge wells, 20 wells recharging at a rate of 50 lpm are feasible.

In recharge modeling, 20 wells of 50 lpm steady state recharge were considered surrounding the tank periphery. The static water level was considered as RL 7.0m. After the simultaneous



recharge from all 20 wells the resulting water level was obtained by model. The contours of water levels are shown in Fig. 8.1. A cross sectional view showing water level mound across tank area is shown in Fig. 8.2. The results indicate that maximum water level of 14.7m is achieved near recharge wells. An average water level below tank area is found to be 14.12m.

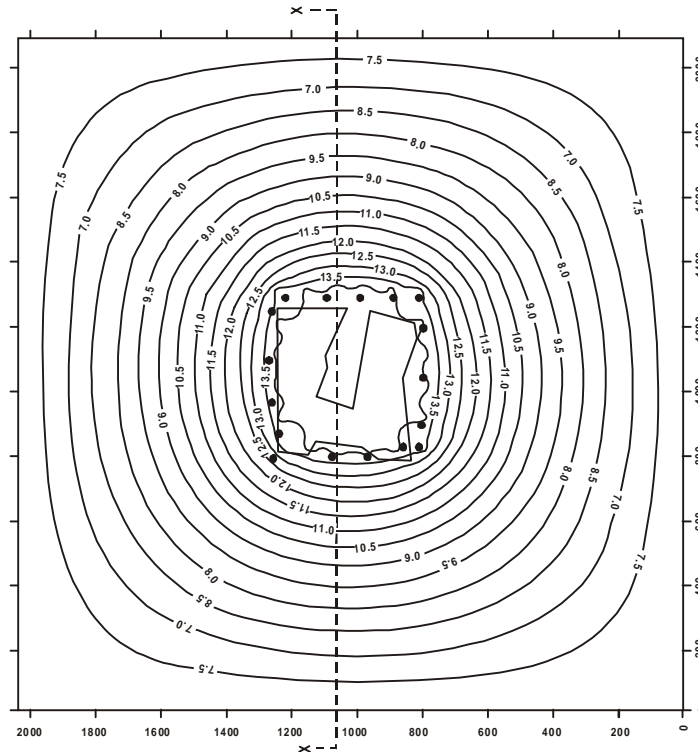

Fig. 8.1 Water level contour in Chhani tank area.

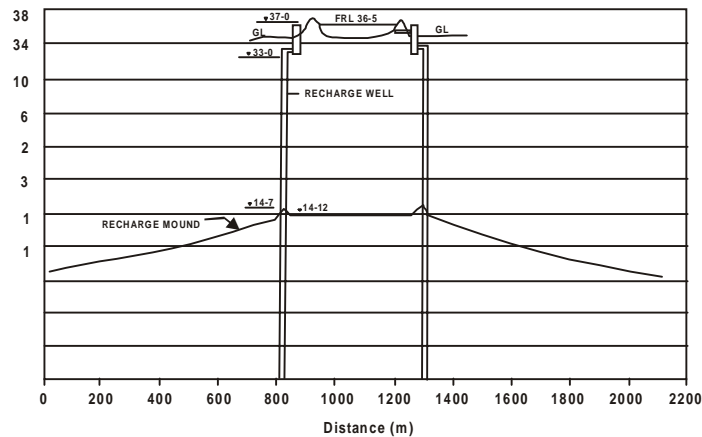

Fig. 8.2 Cross section xx showing water level rise due to recharge in Chhani tank.

**Computer Modeling of Sama Tank:** To carry out recharge study for Sama tank area, another computer model is developed. The study area is discretised in to a grid of 109 rows and 91 columns with variable size. Minimum spacing of 10m is selected in tank area and the grid spacing was increased away from tank area near constant head boundary. The aquifer system is considered as two confined aquifer layers as shown in Table 8.4.

**Table 8.4 Aquifer layers at Sama tank**

Layer	Top RL (m)	Bottom RL (m)	Permeability (m/day)
1	+ 4.0	+ 8.0	0.615
2	+ 16.0	+ 23.5	0.615

The permeability value is adopted from calculation based on field recharge tests. It is assumed that constant head boundary of 9.0m exists about 800m away from tank boundary. In recharge modeling, 10 wells of 30 lpm steady state recharge were considered surrounding the tank periphery. As aquifer system is comprised of two layers, it is considered that each well is recharging water at a rate of 27 m<sup>3</sup>/day in top layer and 15 m<sup>3</sup>/day in bottom layer. The static water level was considered as RL 9.0m. After the simultaneous recharge from all 10 wells, the model obtained the resulting water level. The results indicate that maximum water level of 28m is achieved near recharge wells. An average water level below tank area is found to be 25.5m.

**Recharge Scheme:** It is proposed that water from village tank will be used for recharge through recharge wells. The available water for storage is considered as volume of water between FRL and sill outlet pipe, which leads water, through filter unit to recharge well. Net available recharge water is considered 80 % of total volume, allowing 20 % evaporation losses. As all tanks bed comprise of clay layer, seepage losses are considered negligible. The filter unit is designed as slow sand filter with filtration rate of 3.5 lit/min.

Recharge rate is estimated by recharge test in an exploratory bore at each tank. Number of recharge wells possible at each tank is worked out by dividing net volume of recharge water by recharge capacity exchange of well at each site.

**Chhani Tank:** SWL at exploratory bore was 30.8m below GL. Recharge rate observed at exploratory bore was found to be 37 lpm with 16.3m head i.e. recharge water level 14.5 below GL. Considering that inlet pipe from the tank will approximately be at GL, recharge head can be increased to 25m with recharge level 5.8m below GL. The difference of 5.8m between GL and recharge level is necessary to accommodate filter bed unit of about 2.7m height and pipe losses to supply recharge water from tank to recharge well through filter bed unit by gravity. It is estimated that recharge rate will be 50 lpm with 25m head.

Area of filter bed will be  $50/3.5 = 14.3 \text{ m}^2$ . An area of 20m<sup>2</sup> is provided to allow for reduction in capacity due to clogging. Area of 4m × 5m is provided for filter bed. 4m × 1m dry chamber is provided for installation of control valve and water meter.

Filter bed to provide with 2 layers of sand (0.4m), 2 layers of graded gravel (0.3m) and one layer of gravel (0.4m) for laying 100mm slotted PVC pipe. Recharge well comprising of 200mm hole, 100mm blind/slotted casing and gravel pack.

Volume of water available between FRL 36.5m and outlet pipe sill at RL 33.0m is  $468920\text{m}^3$  ( $604120 - 135200$ ). Net volume available allowing 20% for evaporation losses will be  $468920 \times 0.8 = 375000\text{m}^3$ .

During three monsoon months, there will be overflow. Hence storage will be needed for 9 months i.e. 270 days with recharge rate of 50 lpm i.e.,  $72\text{ m}^3/\text{day}$ , number of wells will be  $375000/(270 \times 72) = 19.29$  say 20 wells.

There can therefore be 20 recharge wells around periphery of tank, at locations, depending on demand of users.

Rise of water level at recharge well is up to RL 14.7m as against maximum possible RL of 33.0 i.e. sill of outlet pipe of filter unit. Additional recharge would have been possible if available water from tank was larger. Total recharge from Chhani tank will be  $72\text{ m}^3$  per day. If domestic water supply requirement is considered as 100 liter/capita/day, this can meet requirement of 720 persons.

**Sama Tank:** SWL was 3.4m below GL. Recharge rate at exploratory bore was 14 lpm at 3.4m recharge head i.e. recharge level just at GL. As exploratory bore was just at bank of tank, GWL was converted to tank water level. A minimum 3m difference is necessary between outlet pipe sill level and recharge level so as to provide filter bed unit and recharge by gravity head. The exploratory bore site is not suitable for actual recharge well. The recharge well location has therefore to be at some distance away from tank where GWL is about 10m lower than outlet pipe sill. By this way, larger recharge will be available. It is informed that recharge rate can be increased to 30 lpm if recharge head is increased from 3.4m to 7.0m. FSL of tank is 36.3m outlet pipe sill is provided at RL 34.0m.

Filter bed area will be  $30/3/5 = 8.0\text{ m}^2$ . However  $12.0\text{ m}^2$  ( $4\text{m} \times 3\text{m}$ ) is provided for probable clogging of filter bed.  $4 \times 1\text{m}$  dry chamber is provided to install control valve and water meter. Filter bed is provided with 2 layers of sand (0.4m), 2 layers of graded level (0.3m) and one layer of gravel (0.4m) for laying 100 mm slotted PVC pipe. Recharge hole comprising of 200mm hole, 100 mm blind/slotted PVC pipe, with gravel pack. Volume of water between FRL 36.3 m and outlet pipe sill 34.0 is  $152870 - 37540 = 35,330\text{ m}^3$ . Net volume available for recharge is  $0.8 \times 135330 = 108300\text{ m}^3$ . During three monsoon months tank will overflow and hence storage will be needed to be used for nine months only. Recharge rate per well is 30 lpm ( $43.2\text{ m}^3/\text{day}$ ). Number of recharge wells feasible =  $108,300/(43.2 \times 279) = 9.2$  say 10.

Therefore, 10 recharge wells around periphery of Sama tank are feasible. They may be provided at location depending on demand of users. Rise of water level at recharge well is up to RL 28.0m as against maximum possible RL of 34.0m i.e. sill of outlet pipe filter unit. Additional recharge would have been possible if available water from tank was larger. Total recharge from Sama tank will be  $43.2\text{ m}^3$  per day. If domestic water supply requirement is considered as 100 liter/capita/day, this quantity can meet requirement of 432 persons.

### 8.3 ARTIFICIAL RECHARGE — SIPHON RECHARGE EXPERIMENT (NATIONAL GEOPHYSICAL RESEARCH INSTITUTE)

An experiment of transferring the supernatant water in the tank to a dry well in the command area using the siphon principle was conducted in Anantapur district of Andhra Pradesh. Anantapur district is located in the low rainfall semi-arid tropical belt of India. The average annual rainfall at Anantapur city is 560 mm (70 years average). Statistical studies indicated that the number of events having rainfall greater than 60 mm in a day during the SW monsoon season is one event per year. The natural recharges studies conducted using tritium injection technique indicated that 7% to 8% of rainfall replenishes the water table aquifer every year. Despite having poor rainfall and recharge, the cropping area in this district has increased from 46,000 hectares to 910,000 hectares (ha) over a period of 100 years. The irrigation requirement is met with tanks and groundwater. The total number of tanks in this district is about 1200. Out of these 274 are large tanks having command area of 40 ha or more.

An old minor irrigation tank called Yerracheruvu is located near Kandukunu village. Due to heavy siltation in the tank bed area (more than 2 meters) over a period of about 90 years, the storage capacity of the tank and the depth of storage have been reduced considerably. The tank evaporation studies indicate that the evaporation rate in the pan, located in the Yerracheruvu tank, over the period June 1986 to January 1987 varied from 5 mm to 8 mm per day. The cumulative evaporation over the period was estimated to be 1.68m column to storage. Because of significant reduction in the storage volume and increase in the area of cultivation in the command area of this tank over the years, the surface irrigation has failed to meet the demands of irrigation. This has compelled the farmers to depend on the groundwater from dug-cum-bore wells. In order to increase the potential of these wells, the farmers have decided to convert this irrigation tank into a percolation tank by closing the sluice. The dug well lithological section and well performance clearly indicate the non-influence of the tank due to poor recharge from the tank bed.

In Yerracheruvu tank, it was noticed that although the tank was full after a thunderstorm, the nearest command area well still remained dry indicating that no percolation was taking place. A study on transferring the tank water to the dug-cum-bore well near the bund (30 meters on the downstream side) was therefore initiated for artificially recharging the aquifer in the command area using siphon principle. The dug well had an in-well borehole to a depth of 16.5 m from the bottom of the dug well. A pit (2.7m × 1.8m × 1.9m), excavated by the farmer around the borehole for installation of pump was used as a discharge point of the tank water. A 2.5 cm diameter plastic pipe with a foot valve at the tank end and a control valve at the pit end was used to transfer the water and for controlling the discharge. A domestic water supply meter was used to monitor and quantify the discharge during the recharge operations. The siphon recharge approach deployed in Kandakuru tank is shown schematically in Fig 8.3.

The recharge experiment was commissioned on July 16, 1986 and terminated on January 20, 1987. The recharge rate varied between 30 and 40 lpm. The recharge rate was adjusted to a steady state level in the pit. Nearly 10,000 cubic meters of water was transferred during the experiment lasting for 190 days. During the recharge, the turbidity and conductivity of the recharge water was monitored continuously. Well performance monitoring has indicated that a bore well in the neighborhood (500 m away) had improved its yield (from 20 lpm to 27 lpm).

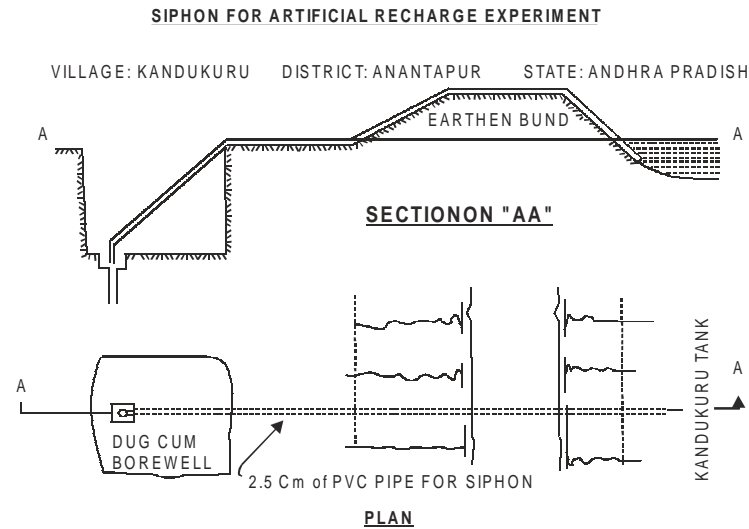

**Fig. 8.3 Schematic diagram for siphon recharge.**

This pilot scale experiment demonstrated that:

- (a) Augmenting the groundwater reserves of an aquifer subjected to overdraft is feasible.
- (b) Using the traditional tank as a silt trap, the artificial recharge will be effective without clogging due to suspended matters.
- (c) Artificial recharge can minimize the losses due to evaporation.
- (d) The effective storage of a tank can be increased by simultaneous artificial recharge operations, and
- (e) The quantum of transfer of tank water to the aquifers can be increased several fold by using larger diameter pipes for the siphons and several wells in the command area.

#### **Design of "Kund" for Rain Water Harvesting — A Case Study of Churu, Rajasthan**

Kund is the complete system for collecting and storing precipitation run off. Kund has two important parts; namely *catchment area* and *storage tank*. Catchment area is artificially prepared, sloping, impervious structure known as *paithan*. Storage on the other hand is done in circular underground tank (also known as Kund or wekk), which is usually placed at the center of the paithan. The storage tanks are filled during monsoon season due to collection of rainwater over the paithan. Water users are thus left with fixed volume of water until the next rainy season. A wire mesh across water inlets prevents debris and reptiles from falling into the well pit. The side of the well pit is covered with lime and ash. Most pits have dome shaped cover (Dhola), or at least a lid, to protect the water. If need be, water can be drawn out with a bucket. The depth and diameter of Kunds depend on their use (drinking or domestic water requirements). Fig. 8.4 shows a typical Kund structure in the Churu district.



**Fig. 8.4 Kund, traditional rainwater harvesting structure.**

The amount of water harvested from water harvesting scheme depends upon the frequency, intensity and duration of rainfall, catchment characteristics, rainwater harvesting method used and response of the system that depends on maintenance and operation of the structure. How long the supply could last depends upon size of storage and water demand. The quality of harvested water depends upon design of structure, operational procedures and on education and sensitization of users on water quality issues.

Use of Kunds is an ancient practice of water harvesting in Thar Desert. The Kunds were and still are owned mostly by community and some privately. The first known construction of a Kund in western Rajasthan was during 1607 AD by Raja Sursingh in village Vadi-Ka-Melan. In the Mehrangarh Fort in Jodhpur, a Kund was constructed during the regime of Maharaja Udai Singh in 1759 AD. During the great famine of 1895-96, construction of Kunds was taken up on a wide scale. Unfortunately use of Kunds as rainwater harvesting structures declined thereafter owing to availability of water through community and other schemes. Though such schemes have provided drinking water at a high cost for human consumption, cattle have suffered as they are fed with the available low quality groundwater. Some of the problems related to Kunds are deterioration in quality water with time making it unacceptable,

development of cracks and hence seepage from catchment area and tank, soil erosion due to improper location/construction of structure, inadequate/sub optimal design, construction and maintenance of structure, silting of catchment area due to shifting sand dunes and failure of cleaning the catchment surface before the onset of monsoon etc.

Recently with lot of emphasis on rainwater harvesting, hundreds of such Kunds were built in Churu district under the drought relief works. Many more projects for construction of such Kunds are under active consideration. It is thought that with technical inputs for design, construction and maintenance of these Kunds they can be developed as sustainable, reliable and economical sources of water with improved quality.

**Study area:** Churu district is located in the North Eastern Rajasthan and is bounded by Ganganagar and Hanumangarh district in North, Sikar, Jhunjhunun and Haryana state in the east, Nagaur in south and Bikaner district in west. It lies between latitude 27°25'10" to 28°59'20" north and longitude 73° 37'30" to 75° 40'30" east. Average altitude is about 400 m from mean sea level. Climate of area is absolutely dry with scanty rainfall. It is very hot during summer and very cold during winter. Annual rainfall of various blocks (tehsils) of 2000 to 2003 as well as normal rainfall is given in Table 8.5.

**Table 8.5 Annual rainfall in Churu District, in mm**

Sr. No.	Name of Tehsil	Normal	2003	2002	2001	2000
1	Churu	355.5	570	288	413	230
2	Sarda Shahar	251	366	110	336	317
3	Ratangarh	420	440	78	257	184
4	Sujangarh	396	371	130	276	352
5	Rajgarh	273	366	210	480	187
6	Taranagar	323	363	157	429	127

There are very few wells in this area for irrigation purpose. The wells, Kuias, Johad and Kunds are used for drinking purpose. The water table depth is comparatively shallow towards eastern half of the district (33 to 56 m). It is deeper towards western half and ranges between 40 and 115.44 m. Practically there is no river in the district, however, in extremely high rainy events Kantli river enters in the extreme southern peripheral village of Rajgarh block.

The undulating sand dunes and sandy plains represent the entire district. Fairly open and flat plains have also been observed in Rajgarh and Sujangarh blocks of the district. Isolated hillocks of considerable height and restricted extension have also been observed towards southeastern part of the district at Gopalpura, Dungras, Balera, Rndhisar and Biramsar. However, one or two small hillocks of granite are also exposed towards extreme north of Rajgarh block at village Galar in block, Rajgarh and village Sandan in block Sujangarh.

The main water bearing formation in the district are younger and older alluvium of quaternary age, tertiary sandstone, Nagaur sandstone, Bilara limestone and Jodhpuri sandstone.

The groundwater in the district occurs under semi confined to confined conditions. The occurrence of perched waterbodies above saturated zone has also been found in some part of Churu, Rajgarh and Taranagar block. These bodies have very limited potential of groundwater. The pH of soil is normal (8 to 8.7) and conductivity of soil is good.

**Methodology:** In order to analyze the present structures, data were collected from 81 existing old as well as recent structures in Churu district. Of these, 13 structures were constructed prior to 1960, 23 were constructed between 1960 and 1980, 1 was from 1980 to 2000. Cost of many of the old structures was not available, however those of last year varies from approximately Rs. 20,000 to 100,000 depending upon the size of structure.

The life of Kund and the user's financial condition play a major role in selection of dependability factor. For drinking water purpose, less risk and so higher dependability factor is considered as compared to the irrigation projects. Table 8.6 shows the size of storage tank for different diameter of paithan considering dependability factors of 90% and 70% and runoff coefficient 0.85.

**Table 8.6 Optimum tank capacity for different Paithan diameter**

Paithan diameter (ft)	20		30		40		50	
Paithan diameter (m)	6.1		9.1		12.2		15.2	
Paithan area (m <sup>2</sup> )	29.2		65.7		116.7		182.4	
Dependability factor	90%	70%	90%	70%	90%	70%	90%	70%
Block/Tehsil	Optimum tank capacity in liters of water							
Churu	4500	7100	10200	16100	18100	28600	28300	44700
Sardarshar	4100	6700	9200	15100	16300	26800	25400	41800
Ratangarh	3700	6400	8400	14300	15000	25500	23400	39800
Sujangarh	5600	8300	12700	18700	22500	33200	35200	51900
Rajgarh	4200	7400	9400	16700	16600	29800	26000	46500
Taranagar	5000	6800	11300	15200	20100	27100	31400	42300

On the basis of data collected of different Kunds, an analysis of their paithan area and catchment area was made. Figure 8.5 shows the points for each combination of paithan area in ft and storage tank capacity in liters. As can be seen, there are wide variations on storage capacity for same size of paithan. For example, for 50 ft<sup>2</sup> of paithan area, storage tank capacity ranging from 32,795 lit. to as high as 269,185 lit. was found. The capacity of tank varied with local mason or person who designed it and was mostly based on their past experience. A linear trend line shows some correlation between paithan size and storage tank capacity but correlation is not very strong with R<sup>2</sup> (coefficient of determination) value of only 0.42. Correlation equation is:

$$\text{Storage tank capacity in liters} = 2328.9 \times \text{Paithan diameter in ft} - 32435 \text{ (Fig. 8.5)}$$



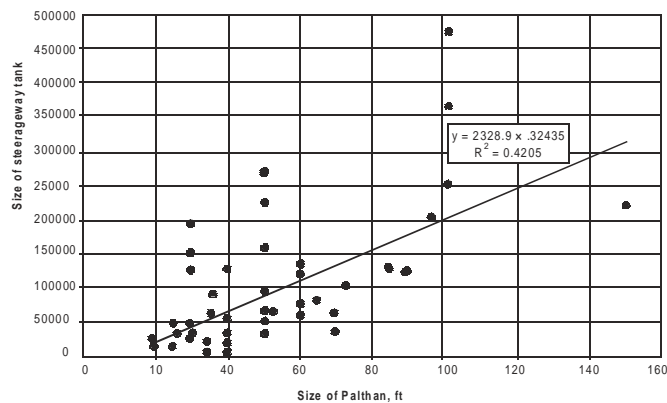

**Fig. 8.5 Relation between Paithan size and storage capacity.**

With this equation average capacity of storage tank works out to 14,100 liters for 20 ft<sup>2</sup> paithan area and 84,000 for 50 ft<sup>2</sup> paithan area, which indicates that most of the time, storage tanks are traditionally designed for less than 50% dependability factor, still some of the tanks were much below the desired storage capacity of 90% dependability factor. For example a 40 ft paithan area tank was found with the storage capacity of only 2,800 liters.

A similar analysis of slope indicated that the slope of catchment area varied with construction material used, finish of catchment area, and the person who undertook the work of Kund. The slopes varying from 0.75% to 5% were found in existing structures.

The above analysis indicates that some guidelines should be made for optimal design of such Kunds for the future projects to conserve the rainwater at a high efficiency. Also, the structures need certain considerations for ensuring a better maintenance of the quality of water stored. Some recommendations based on the present study are as follows:

1. The paithan size must be calculated based on the required capacity of storage tank, design annual rainfall, dependability factor and runoff coefficient as suggested above.
2. The demand of water consideration should be based on I S recommendation. The Kund for individual family of 5 members normally should be 20,000 or 22,000 liters capacity.
3. Slope 1.5% is recommended for paithan.
4. The storage tank of the Kund should be constructed at the one end of paithan in case Kund is constructed for drinking water purpose. This will ensure better quality of stored water, as the users themselves would not contaminate the paithan.
5. A small ditch should be provided at the bottom of Kund to remove water. This will facilitate proper cleaning of tank from time to time.
6. Over flow arrangement for first flush (for drinking water Kunds) should be made.
7. Enough funds should be earmarked for maintenance of Kunds as it was found that in absence of maintenance the paithan and tanks leaked and so the Kunds become useless.

8. Since the cost of Kund per liter of water decreases as the size of Kund is increased, efforts must be made to construct large capacity Kunds for more number of users. However it is found that the maintenance of such structures is poor, so efforts must also be made to ensure proper maintenance of such structures.
9. To promote the economic development of the village community and employment generation Kund water can be used for horticulture purpose.
10. In Churu district groundwater contains alarming quantity of fluoride. If Kund water is mixed with groundwater, it can bring some respite for man and cattle. The Kund can be designed for a family with a due consideration given to the demand for cattle.

**Roof Top Rain Water Harvesting Storage cum Artificial Recharge to Check the Gradual Lowering of Piezometric Water Surface of the Ground Sources as well as Improvement of Groundwater Quality in and around DUMDUM:**

South Dumdum Municipal area is probably the most densely populated area of all the municipal bodies in West Bengal. It has experienced a steady growth in the last 250 years. People from different parts of the country have come here in search of livelihood. A major influx of people occurred after the partition of Bengal and settled indiscriminately wherever they found space. The present population of South Dumdum Municipal area is about 450000. On account of growth of unplanned settlement in and around Dumdum, the availability of civic amenities is becoming scarce everyday. One such problem is acute scarcity of safe drinking water. The supply of water from groundwater source is more than 33500 kiloliters per day through big and small diameter tube wells as well as private tube wells. This figure is increasing with the expansion of urban complexes, rise in population and industrial development.

To cope up with the increasing demand, groundwater is being withdrawn indiscriminately in the city that in turn is posing serious threat to the safety of the city structure due to gradual lowering of piezometric surface in the range of 5 – 10 meters in the city. Moreover, the availability of groundwater in the lean period is also a great concern. The aim of this project is to explore the possibility of augmentation of groundwater resource in the area by roof top rainwater harvesting cum storage cum artificial recharge of groundwater. We felt that this is specifically needed in the area because though average rainfall in the area is high but due to non-availability of suitable surface area for percolation, the run off is maximum and percolation of rainwater is less. Moreover, rain water being the purest form of water, can improve the quality of groundwater that is getting deteriorated day by day.

**Objective:** The main objective of the project was to assess the possibility of sustainable development of groundwater in the area where natural percolation of rainwater is very limited due to non-availability of suitable surface area conducive for percolation due to extensive urbanization. The South Dumdum Municipal authorities initiated the pilot project of “Roof Top Rainwater Harvesting – Storage cum Artificial Recharge” at the municipal office building at Nagar Bazar, Kolkata. The basic idea is to catch the surface run off from the rooftop through a piping network system, i.e. collecting from the roof and getting it connected to the collection cum recharge storage pit for onward transmission to the injection well newly installed for the artificial recharge.

Study of the lithological log of the tube wells constructed in the area indicates that beneath a thick clay bed (35 – 45m) there occurs an aquifer of moderately good groundwater potential down to the depth of 45 – 150 m with thin intervening clay layers. This aquifer is being exploited by a large number of tube wells, as a result of which the groundwater level (piezometric surface) has been lowered considerably in the last two decade. The present disposition of piezometric surface of groundwater is around 15 m below ground level. It is reported that in the last two decades there has been a significant drop of piezometric surface level in the tune of 5 to 9 m in this area. Since the aquifer is composed of medium to coarse-grained sand of moderate permeability, the water harvesting potential is quite high in this aquifer.

Considering different hydrometeorological, hydrological and hydrogeological aspects, it was decided to construct roof top rain water harvesting system with primary objective to recharge to groundwater in the underlying aquifer and to create storage of rainwater of 20000 liters capacity for utilization for the purpose like washing of pavements, car washing, gardening etc.

Based on the size of the roof area, available rainfall in the monsoon months and roof catchment efficiency, it is considered that a total quantity of 4, 50,560 liters can be available from rainwater harvesting of the rooftop of the building. Allowing a storage facility of 20000 liters in the storage tank that has been created, rest of the harvested rain water would be recharged to groundwater.

The other objective was to examine the possibility and extent of qualitatively and quantitatively improvement of the groundwater that is deteriorating increasingly. A monitoring well is placed at a distance of 100 feet down gradient for surveillance purpose.

**Profile of Area:** The boundary of the area has always been expanding since its birth. The area has railway track as its western boundary from Patipukur to Bediagara, Baguiati canal as its eastern boundary, Clive House as its northern boundary and Dakshindari as its southern boundary.

Latitude and longitude of city : 22°28'00" : 22°37'30"  
80°17'30" : 88°25'00"

*Climate :*

Type of climate : Tropical sub-humid to humid

Maximum Temperature : 40.3° C

Minimum Temperature : 10° C

*Rainfall:*

Average Annual Rainfall : 1600 mm

Distribution of Rainfall :

January	17.60 mm	July	308.70 mm
February	29.40 mm	August	320.50 mm
March	35.38 mm	September	241.00 mm
April	50.00 mm	October	117.60 mm
May	126.40 mm	November	32.34 mm
June	273.42 mm	December	7.35 mm

**Geological formation:** The area is located on the lower deltaic plain of the Ganga Bhagirathi delta. It is covered by the sediments deposited by the river system flowing through it during quaternary period. The succession of sediments of Quaternary age consists of clay, silt, fine — medium to coarse sand and occasional gravel and pebbles. Both recent and Pleistocene sediments have been deposited successively by the Ganga River as the flood plain deposits. From the study of litho logical logs generated from boreholes drilled by different agencies, it can be concluded that the lithological sequence is topped by a clay layer of 30 – 60 thickness in this area. The top clay layer is followed by fine to medium sand layers of clay and sand bed. The floor of the quaternary deposits in this area may be fixed at depth between 296m and 414m below ground level. Two horizons of pit have been observed in the boreholes between 2 -5m and 12m and 12.6m during the metro railway excavations. The litho log of area is characterized by the occurrence of a clay bed in the upper part of the sedimentary column and another clay bed at bottom. Both the upper and bottom clay beds are dark grey in colour, sticky and are plastic to semi-plastic in nature. A conspicuous feature is the occurrence of fine to coarse sand horizon mixed occasionally with gravel and sandwiched between clay beds.

The continuity in the sequence of sand, which forms the aquifer material, is broken by the occasional occurrence of clay lenses of limited lateral extent. The entire sandy sediment up to a depth of 150 meters is on an average moderately well sorted. The borehole lithologs indicate the occurrence of yellow to brownish coloured sand in the depth span of 20 to 80 m, which suggests oxidizing condition of deposition. The colour of the sediments occurring below the above horizon varies from grey to light grey which appears to have been deposited under reducing conditions.

*Hydrogeology:* Quaternary sediments having a sequence of clay, silty clay, sand and sand containing gravel underlie SDDM area. The upper layer is underlined by coarse clastic consisting of sand, fine medium and coarse grain mixed with gravel in some places. These coarse clastics form the aquifer. The shallow aquifers that are available within less than 20 meters level are water table aquifers.

The sediments exhibit typical deltaic deposition showing facies variation at a few places having sand and pebbles from the aquifer materials. The most prolific water bearing formation is available within 60 – 180 meters consisting of fine to medium sand of 20 – 40 meters thickness. However, in places brackish water aquifers capped the freshwater aquifers.

The piezometric surface of fresh water aquifer on the central part of the city has been lowered by 5 – 9 meters over the last four decades and as a result of which the flow direction of groundwater has changed from southerly to easterly and south easterly direction. This is due to over extraction of groundwater compared to natural recharge.

The deeper aquifer in SDDM area is recharged from northern and western part of the area outside Kolkata where these sand beds are exposed almost near to the surface. These areas are mainly in Kanchrapara – Kalyani – Ranghat – Shantipur area in Nadia District in North. The near surface aquifers of these areas that get recharge mainly from the rainfall and this water infiltrates into the deeper aquifers of SDDM area.

With the progress of urbanization, the groundwater withdrawn has been increased to an alarming extent. The depletion of the piezometric head has been registered most prominently in SDDM area.

As in some areas of SDDM has been a major decliment of piezometric head observed and the groundwater exploitation can't be stopped, the need for artificial recharge of this aquifer is strongly felt.

**Rooftop Rainwater Harvesting:** From the record, it has been observed that the static water level (SWL) has dropped from 8.84m below ground level in 1994 to 13.85m below ground level in 2004, i.e. in the last ten years the SWL has lowered by more than 5 meters. This is indeed an alarming situation and unless augmentation of groundwater is done through rainwater harvesting, both the quality and quantity of groundwater in the area is bound to be affected adversely.

Keeping above in mind and office of the Councilors of South Dumdum Municipality, Kolkata entrusted the job of roof top rainwater harvesting cum artificial recharge of groundwater at the office building of the Municipality. Rainwater harvesting potential of the building was carried out as per the following details:

Average rainfall per annum: 1600 mm

Rain water collection efficiency = rainfall (mm) × collection efficiency  
= 80 % of maximum rainfall = 1280 mm

Available roof top area in the office building is 550 m<sup>2</sup>

Height of rainfall = 1.28 m

Volume of rainfall = Area × height of rainfall = 704 m<sup>3</sup>

Coefficient of roof catchment = 0.8

Coefficient of evaporation, spillage and first flush = 0.8

Harvested potential = 704 × 0.8 × 0.8 = 450.56 m<sup>3</sup> = 450560 liters

Work done:

- All the rainwater drop pipes were connected in Ring Main System with a slope towards the collection pit.
- SWR water drop pipes of 100 mm were connected horizontally in 150 mm diameter pipes with inclination that was reduced to 100 mm diameter pipes for gaining velocity up to the collection pit. Strainer has been provided for arresting unwanted solids, leaves/straws etc. Arrangement for flushing the first rainwater has been provided before rainwater enters the collection pit by providing suitable valves.
- 150 mm diameter SWR pipes drawn from collection pit to the recharge pit.
- Overflow pipe for recharge pit has been provided.
- An air vent above the tubewell is also to be provided.
- Sinking of 150 mm diameter tubewell upto a drilled depth of 105 meters and lowered depth of 99 meters BGL by providing PVC casing pipes and ribbed screens having

1 mm slot width. The discharge of the newly sunk tube well had been recorded to be 15100 Imperial gallons per hour. During the heavy monsoon period, it has been observed that the tube well sunk for artificial recharge of groundwater is capable of recharging all the water that overflowed to the well from the storage tank.

- The total cost of the completed project — Rs. 421,572/-.

### ***Artificial Recharge Experiment for Underground Storage of Water Based on Siphon Principle***

The principal source of natural replenishment to aquifers is infiltration from precipitation. This annual replenishment of aquifers is limited to a small fraction of precipitation due to runoff and evaporation. The situation is even worse in arid and semi-arid regions like Gujarat, where the loss due to evaporation is high. As a result of rapid development in agriculture and industry during the last two decades, demand for water in Gujarat has increased enormously. In absence of available surface water supplies, the groundwater reservoir has been subjected to large-scale exploitation through an increasing number of tube wells by both government and private agencies. This heavy withdrawal of groundwater has resulted in lowering the water level at an alarming rate in parts of north Gujarat. One of the methods of remedying the situation is artificial recharging of aquifers in this region. A recharge scheme involving purification of water through the upper sand layers in the Sabarmati riverbed and its direct injection to a tube well on the riverbank through a siphon arrangement was suggested by Physical Research Laboratory, Ahmedabad. The construction of tube wells and other arrangements were done by Gujarat Water Resources Development Corporation.

**Experimental Details:** A 350 mm diameter shallow gravel packed tube well (depth 21.34 m) was constructed in the riverbed of Sabarmati River adjacent to the fair weather bridge linking Gandhinagar with Ahmedabad via Hansol. This well taps the unconfined aquifer in the riverbed between 6.04 and 21.34 m below riverbed level. This well (source well) is used to supply adequate quantity of naturally filtered river water. The water from the source well flows into a deep tube well (depth 238 m), (hereafter called injection well) tapping confined aquifers below 74 m depth. A schematic diagram showing the arrangement of source well, injection well, connecting siphon pipe and observation well at the site of experiments is shown in Fig. 8.6.

The injection recharge experiments was started at 10.53 hours on 29th May 1977 and continued till 15.55 hours on 7th June 1977, when it was stopped for studying the dissipation or recharge mound. The priming of the siphon was adopted by evacuating the siphon pipe using a water ring type vacuum pump of capacity 50 m<sup>3</sup>/minute. During the period of experiment water level fluctuations in (i) injection well and (ii) the observation well was regularly monitored at suitable intervals. Recharge rate during a given interval was computed from the readings shown by a flow meter on the siphon pipe.

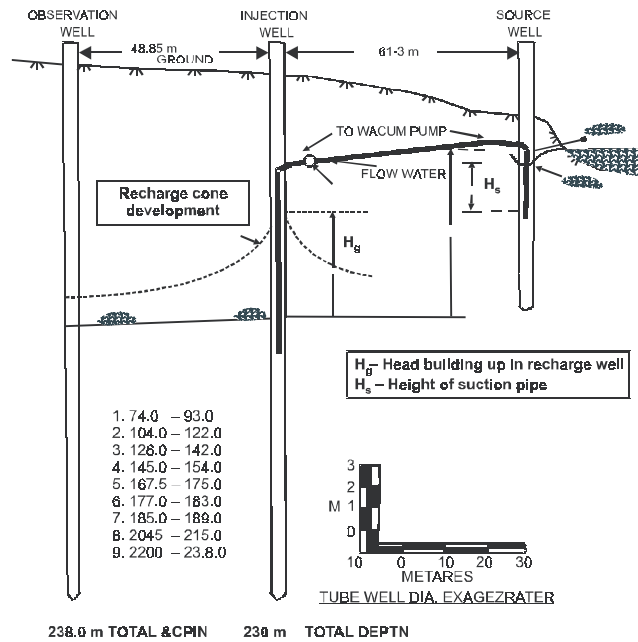

**Fig. 8.6 Schematic diagram of siphon, source well, injection well and observation well (suggested by J F Mistry 1988).**

**Data Analysis:** Before the start of recharge test, difference in water level between the source well and injection well was 7.06 m. This represents the net available head ( $H_T$ ) in the present system. After the recharge was started on 29th May 1977 (at 10.53 hours), water levels in injection and observation wells were monitored at suitable intervals. At steady state, the following conditions were observed:

- Recharge rate ( $Q$ ) = 590 lpm
- Build-up in the injection well ( $H_B$ ) = 5.18 m
- Drawdown in the source well ( $H_D$ ) = 0.70 m
- Build-up in the observation well = 1.15 m
- Head loss due to flow in siphon ( $H_S$ ) including velocity head ( $H_V$ ) =  $H_T - (H_B + H_D) = 1.18$  m

According to Todd (1959), if water is admitted into a well, a cone of recharge is formed which is similar in shape but is reverse of a cone of depression surrounding a pumping well. Assume aquifer formula used during pumping also valid during recharge. The average values of coefficient of transmissivity ( $T$ ) and storage ( $S$ ) estimated from the recharge data are 540 m<sup>2</sup>/day and  $3 \times 10^{-5}$  litres respectively. Using these values of  $T$  and  $S$  in Theis formula to be 2.89 m, compared to an observed build up of 5.18 m in the injection well. This gives an injection well efficiency = 56%.

The radius of influence is estimated by using slope ( $\Delta S_t$ ) of time build up plot and constituting the distance build up plot using  $\Delta S_t = 2\Delta S_r$ .

Using the formula for steady uni-directional flow in a leaky artesian aquifer (Huisman, 1972), the permeability ( $k$ ) of the unconfined aquifer in the riverbed is estimated to be 70 m day.

It was earlier shown that at steady recharge rate, loss of head due to flow of water through the siphon (i.e.  $H_s + H_v$ ) is 1.18 m. However, for recharge rate of 590 lpm through 200 mm diameter siphon pipe the velocity head is only 5 mm and hence not considered. Using tables based on William and Hazen's formula for estimating head loss through a 200 mm diameter standard pipe, the equivalent length of the siphon pipe for the observed head loss of 1.18 m works out to 1180 m. This, when compared with the actual, 75 m length of siphon pipe indicates the extent of head loss due to: (i) Entrance, (ii) two 90° bends, (iii) pipe joints and welding, (iv) sluice valve, (v) flow meter, (vi) sudden contraction and expansion (there is 2 m segment of 150 mm diameter pipe in the line), (vii) several ups and downs and (viii) exit of water etc. Head loss due to all these, affects the recharge rate of system adversely. In suitably designed siphon, it is possible to reduce this head loss significantly as has been shown later, to achieve a higher recharge rate through the system.

The efficiency of the injection well is observed to be about 56%. For economical recharging operation, it is desirable to have wells with as high efficiency as possible. In practice, it may not be difficult to construct wells with 75 – 80% efficiency. Increased efficiency of the injection well will result in lesser build-up in the injection well, which in turn results in an increased available head for siphon and ultimate increase in the recharge rate. In the following we estimate the increase in recharge rate for assumed well efficiencies and improved low resistance PVC siphon keeping other parameters of the experiment constant.

Using the values of coefficient of transmissivity ( $T = 540 \text{ m}^2/\text{day}$ ) and storage ( $S = 3 \times 10^{-5}$  litres) as determined from the recharging test, steady state build-up ( $H_b$ ) for various injection well efficiencies (56%, 70%, 80% and 90%) has been calculated for different recharge rates. This formula has been used in these calculations. Steady state draw down ( $H_d$ ) in source well for different recharge rates have been estimated using the value of 18 hydraulic conductivity ( $K = 70 \text{ m/day}$ ) estimated earlier from the recharge test. Source well efficiency is assumed 100%.

The loss of head in the siphon ( $H_s$ ) can be easily reduced to 30% of its present value by reducing the number of bends, welded joints etc. and by using a continuous non-collapsible 200 mm diameter PVC pipe. It can be seen from Fig. 3 (P 203 JFM) that in the improved system steady state rate of recharge at Hansol may be expected to be 680 lpm for 56%, 800 lpm for 70%, 890 lpm for 80% and 970 lpm for 90% injection well efficiency. The expected recharge rate in Ahmedabad (for a minimum available head of 25 m) by using this system will be higher than 2170 lpm for 56%, 2500 lpm for 70%, 2700 lpm for 80% and 2990 lpm for 90% injection well efficiency. It may be noted that in estimates made above, the value of Transmissivity and available head considered are lower than those estimated by Sharma and Desai (1974) at Ahmedabad ( $T = 745 \text{ m}^2/\text{day}$ ) and  $H_T > 30 \text{ m}$ ) and therefore the projections made are in fact conservative.

Consequent upon increase in recharge rate, the velocity of water across the screens, in both injection and source well will increase. In order to minimize corrosion and to reduce, any possible suction of silt from the source well it is desirable to increase the open area of screens.



This may be easily done by increasing the well diameter and changing the design of slotted section and artificial filter.

#### 8.4 WATER QUALITY IMPROVEMENT BY ARTIFICIAL RECHARGE — KANHA PROJECT, VADODARA

**Geology:** The site is covered by a recent to sub-recent alluvium formation followed by tertiary beds. The details of the bore well dug by GWRDC in Kalali have been mentioned in the data collection. From available lithological data, it can be said that aquifer stratification of the study area consists of topsoil upto 3.5m followed by yellowish clay layer upto 10m, which is underlain by dull brown sandy strata of thickness 37.8 m. The next sandy layer is preceded by sticky reddish brown to yellowish clay layer of about 17m. Information beyond 61.2 m below ground level is not available. The depth to water table varies between 14 and 18 meters, across the site according to topography. The landfill site lies on the northwest side of the tributary of Vishwamitri River.

**Description of the Problem:** The case can be considered as contamination of groundwater resource by leachates. The contaminated discharge well (having diameter 200 mm and 110 ft deep) under study is located at Kanha project in the vicinity of the VMC landfill. The main reason of contamination being that the landfill is located near the tributary of Vishwamitri River, which overflows during monsoon and floods the landfill site and hence there is a potential for high leachate generation (Fig. 8.7). Secondly, the leachates generated from the landfill can penetrate into the ground and thus contaminate the underlying aquifer since the landfill has not been originally designed to accept waste and there is no information available regarding placement of geomembrane or any other such material at the base, which acts as a barrier. Henceforth, the risk of having a high volume of leachates and its subsequent seepage into the ground is high. The third reason is that contamination by leachate poses a great threat to groundwater resources since leachates contain multiple pollutants, which might not be easy to remove or treat.



*Fig. 8.7 Landfill site.*

As the remedy was to be designed for a single well, privately owned by Kanha Project, the cost effectiveness of the remedy was of foremost importance. Hence solutions such as the method of “pump and treat” in order to contain the contaminant plume were not feasible. So, the technique of artificial recharge was selected as a remedial measure and a recharge well

was, thus, introduced in the vicinity of the existing contaminated discharge well on site. By doing so dual purposes were solved, firstly, the discharge well was made contaminant free by generation of a Rankine oval body obstructing the path of the uniform flow of groundwater in the contaminated confined aquifer and secondly, the runoff from the paved roads of the residential project was judiciously utilized for the artificial recharge.

**Arrangements Made at Kanha Project for Artificial Recharge of Groundwater:** For the purpose of implementing artificial recharge of groundwater, a Rain Water Harvesting (RWH) system was introduced at Kanha Project (Fig. 8.8). Gutters or galleries have been provided along the length of the internal paved roads for collection of storm water, these gutter lines have intermittent collection chambers, which finally drain, into an underground storage tank (Fig. 8.9). A recharge well of diameter 200 mm, about 110 ft deep, has been bored at the base of this underground storage tank. The center-to-center distance between the recharge well and the discharge well is 7.2 m. The introduction of the recharge well in the vicinity of the discharge well can thus be imagined as source and sink placed at equal distance from the origin. The composite flow occurring as a result of the superimposition of this source-sink pair with the uniform flow in the contaminated aquifer forms a Rankine oval body according to the principles of groundwater hydraulics and potential flow. The Rankine oval body, thus formed, separates the two wells (sourcesink pair) from the rest of the contaminated flow in the aquifer. This was analytically established by generating a flow net using actual field data of the Kanha Project. A Rankine oval body of height 4.6m from origin and having stagnation points at 6m on either sides of the origin was obtained as a result. The water quality of the discharge well under study was checked and compared before and after the artificial recharge well was introduced. The comparison shows significant improvement in quality of water as a result of artificial recharge and it is also found fit for drinking purpose (Table 8.7).

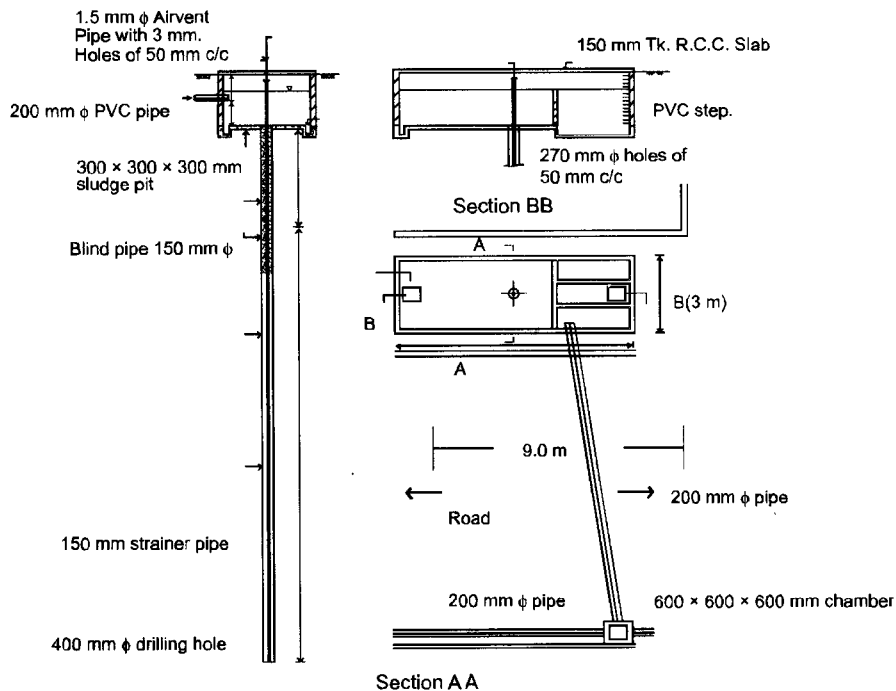

Fig. 8.8 Rainwater harvesting system at Kanha project.

The outcome of the study will provide an insight of the existing situation and can also be used to aid in decision making for planning issues such as issues related to remediation of the contaminated aquifer, water resources development, health hazards, etc.

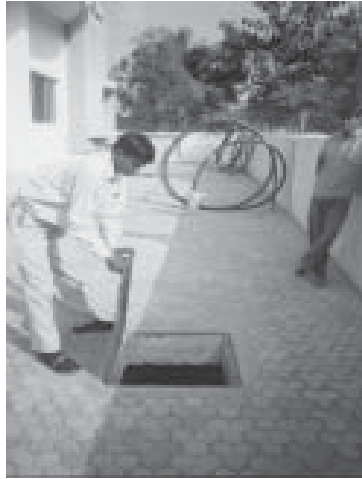

Fig. 8.9 Storage sump to collect rainwater from terrace.

Table 8.7 Groundwater quality of discharge well under study before and after introduction of the recharge well

Characteristics	Before 18-12-02	After 23-12-03	SO-10500:199 (F.R)	
			Desirable	Permissible
Total dissolved solids (TDS) in mg/l	1481.90	894.00	500	2000
Bicarbonates in mg/l	866.20	464.00	200	600
Chloride in mg/l	149.10	200.00	250	1000
Calcium in mg/l	8.00	48.00	75	200
Magnesium in mg/l	21.60	53.00	30	100
pH	7.69	7.80	6.5	8.5

Application of groundwater hydraulics to the problem

Aquifer details:

$$\begin{aligned} \text{Hydraulic conductivity, } K &= 32.48 \text{ m/day} \\ &= 3.76 \times 10^{-4} \text{ m/sec} \end{aligned}$$

$$\text{Hydraulic gradient, } i = dh/dl = 0.01$$

$$\begin{aligned} \text{Velocity of Uniform Flow, } U_0 &= K \times i \\ &= 3.76 \times 10^{-4} \times 0.01 \\ &= 3.76 \times 10^{-6} \approx 4 \times 10^{-6} \text{ m/sec} \end{aligned}$$

Details of source and sink:

$$\text{Discharge of well, } Q = 144 \text{ lpm} = 2.4 \times 10^{-3} \text{ m}^3 / \text{sec}$$

$$\text{Total water bearing strata tapped, } b = 30 \text{ m}$$

$$\text{Strength of source and sink, } m = Q / b$$

$$= (2.4 \times 10^{-3}) / 30$$

$$= 0.8 \times 10^{-4} \text{ m}^3 / \text{sec/m}$$

Estimation of composite stream function for source, sink and uniform flow (Fig. 8.10).

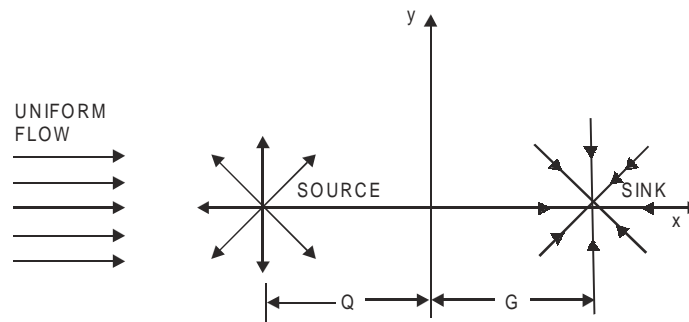

Fig. 8.10 Estimation of composite stream function for source, sink and uniform flow.

Distance between source and sink = 7.2 m

The source and sink are required to be placed equidistant to the origin for generating a flownet of the composite flow.

Therefore, distance of source and sink with respect to origin,  $a = 3.6 \text{ m}$

Co-ordinates of source =  $(-3.6, 0)$

Co-ordinates of sink =  $(3.6, 0)$

Composite stream function:

$$\Psi = \Psi_{\text{uniformflow}} + \Psi_{\text{source}} + \Psi_{\text{sink}}$$

$$= U_0 y + \frac{m}{2\pi} \theta_1 - \frac{m}{2\pi} \theta_2$$

$$\Psi_{\text{uniformflow}} = U_0 y = 4y \times 10^{-6} \text{ m}^2/\text{sec}$$

$$\Psi_{\text{source}} = \frac{m}{2\pi} \theta_1 = \frac{0.8 \times 10^{-4}}{2\pi} \theta_1 = \frac{40 \times 10^{-6}}{\pi} \theta_1$$

$$\Psi_{\text{sink}} = -\frac{m}{2\pi} \theta_2 = -\frac{0.8 \times 10^{-4}}{2\pi} \theta_1 = -\frac{40 \times 10^{-6}}{\pi} \theta_1$$

Table 8.4: Stream functions for source, sink & uniform flow

$\theta$		Distance 'y' w.r.t. origin	$\Psi_{Uniform}$ $\Psi_u = 4y \times 10^{-6}$	$\Psi_{Source}$ $\Psi_w = -\frac{40 \times 10^{-6}}{\pi} \theta_1$	$\Psi_{Sink}$ $\Psi_w = \frac{40 \times 10^{-6}}{\pi} \theta_2$
Deg	Rad	m	$m^2/sec$	$m^2/sec$	$m^2/sec$
9	$\pi/20$	0.5	$-2 \times 10^{-6}$	$-2 \times 10^{-6}$	$2 \times 10^{-6}$
18	$\pi/10$	1	$-4 \times 10^{-6}$	$-4 \times 10^{-6}$	$4 \times 10^{-6}$
36	$\pi/5$	2	$-8 \times 10^{-6}$	$-8 \times 10^{-6}$	$8 \times 10^{-6}$
45	$\pi/4$	2.5	$-10 \times 10^{-6}$	$-10 \times 10^{-6}$	$10 \times 10^{-6}$
72	$2\pi/5$	4	$-16 \times 10^{-6}$	$-16 \times 10^{-6}$	$16 \times 10^{-6}$
90	$\pi/2$	5	$-20 \times 10^{-6}$	$-20 \times 10^{-6}$	$20 \times 10^{-6}$
108	$3\pi/5$	6	$-24 \times 10^{-6}$	$-24 \times 10^{-6}$	$24 \times 10^{-6}$
126	$7\pi/10$	7	$-28 \times 10^{-6}$	$-28 \times 10^{-6}$	$28 \times 10^{-6}$
135	$4\pi/5$	7.5	$-30 \times 10^{-6}$	$-30 \times 10^{-6}$	$30 \times 10^{-6}$
144	$8\pi/10$	8	$-32 \times 10^{-6}$	$-32 \times 10^{-6}$	$32 \times 10^{-6}$
162	$9\pi/10$	9	$-36 \times 10^{-6}$	$-36 \times 10^{-6}$	$36 \times 10^{-6}$
180	$\pi$	10	$-40 \times 10^{-6}$	$-40 \times 10^{-6}$	$40 \times 10^{-6}$

Estimation of dimensions of Rankine oval body

Location of stagnation point:

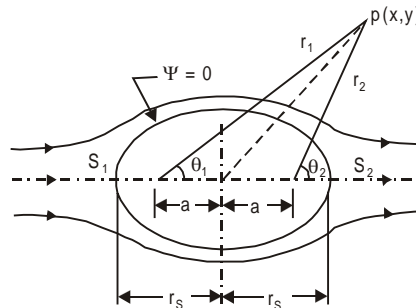
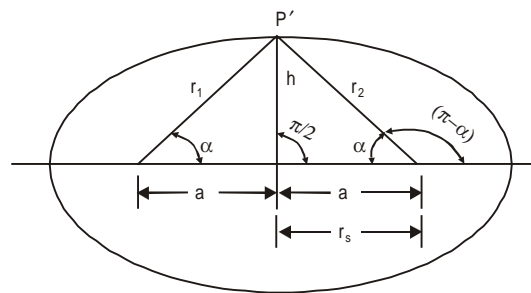

Fig. 8.11 Location of stagnation points.

$$\begin{aligned}
 \text{Stagnation point, } r_s &= a \sqrt{1 + m / \pi a U_0} \\
 &= 3.6 \sqrt{1 + \frac{0.8 \times 10^{-4}}{3.14 \times 4 \times 10^{-6} \times 3.6}} \\
 &= 5.9908 \text{ m} \\
 &\approx 6.0 \text{ m}
 \end{aligned}$$

Hence co-ordinates of the two stagnation point w.r.t. origin are **(-6,0)** and **(6,0)**



**Fig. 8.12 Maximum height of Rankine oval body.**

$$h = a \cot \frac{\pi h U_o}{m}$$

$$h = 3.6 \times \cot \frac{3.14 \times h \times 4 \times 10^{-6}}{0.8 \times 10^{-4}}$$

By trial and error, the value of **h** is **4.38 m**

Analytical Result

Distance of stagnation point w.r.t. origin,  $r_s = 6.0$  m

Maximum height of Rankine oval body,  $h = 4.38$  m

**This page  
intentionally left  
blank**

# PERFORMANCE INDICATORS OF ARTIFICIAL RECHARGE STRUCTURES

## 9.1 INTRODUCTION

Groundwater use for domestic, industrial and agricultural purposes in India has been growing steadily over the years. The report of the Groundwater Resources Estimation Committee (GWREC) has indicated that in India during the period 1952 – 1992, the number of dug wells increased from 3.86 million to 10.12 million, while the number of shallow tube wells increased from 3000 to 5.38 million. The total area irrigated by groundwater increased from 6.5 million ha. in 1951 to 35.38 million ha. (gross) in 1993. Of the 716 blocks in the country, 250 (3.5%) are “overexploited” while 179 (2.5%) are “dark” (GWREC 1997).

A substantial portion of the hard rock belts of India, area is experiencing acute conditions of groundwater overexploitation as a result of phenomenal increase in the rates of abstraction of groundwater, particularly by the agricultural sector which far exceeded the recharge rates. Groundwater resources in the hard rock areas face the twin problems of overexploitation and groundwater pollution. Steep lowering of groundwater levels and the consequent decrease in well yields has started affecting even small rural communities, creating social tensions between neighboring villages and even among individuals within the same village.

While insufficient availability of groundwater is one side of the problem, the deteriorating quality of groundwater is the other side, equally vexing. Pollution of groundwater due to external contaminants produced by industrial, urban and agricultural activities is quite well documented (Bhatnagar and Sharma, 2001); overexploitation of groundwater that leads to lowering of groundwater levels also leads to increasing content of total dissolved solids (TDS) in groundwater.

A major problem encountered in developing groundwater resources in hard rock areas is the sharply declining groundwater levels, leading to the formation of overexploited pockets. Bore wells drilled in hard rocks often become unproductive as the weathered / partly weathered rocks as well as the shallower water bearing fracture zones progressively become desaturated. In such areas, bore wells are drilled deeper year after year with the hope of encountering deep fracture zones leading to mining of groundwater, since there is no replenishment of the deep fracture zones taking place.



Now that overexploitation exists in many parts of India, it is worthwhile to briefly examine as to what constitutes an overexploited area and the indicative hydro-geological parameters characterizing such areas. The report of GWRDC (1997) recommends that using the ratio of net draft to total utilizable groundwater resources can assess the level of groundwater development in area. Areas with stage of groundwater development less than 65 % are classified as “white” those with 65 % but less than 85 % “grey” more than 85 % but less than 100 % as “dark” as and more than 100 % as “overexploited”. The report further adds that over exploited areas show significant long-term decline in both pre and post-monsoon groundwater levels.

An area may be classified as overexploited if one or more of the following hydrogeological features are encountered:

- When groundwater levels do not recover to their original levels on a long-term basis
- When discharge exceeds recharge by an appreciable volume
- When shallow aquifers progressively become unproductive
- When groundwater is pumped from depths greater than that to which adequate recharge currently takes place
- When the natural gradient is reversed and remains so throughout the year.

In order to counter the overexploitation of hard rock aquifers, the concept of rainwater harvesting and artificial recharge to the groundwater system has lately caught the imagination of technocrats dealing with water resources as well as lay public. It is well known that artificial recharging of aquifers has in many cases resulted in a remarkable recovery of groundwater levels locally in the vicinity of artificial recharging structures, at least in the first few years of their construction.

The most common artificial recharge structures are percolation ponds, check dams, sub-surface dykes, spreading basins and injection wells.

Out of these structures a detailed study of performance of percolation tanks, check dams and dual purpose wells (ASR wells) was carried out by the author in Saurashtra region of the Gujarat State of India. The details are described in this chapter.

The ever-increasing demand for water and the deteriorating quality of available groundwater resources have already precipitated a major water crisis in the Saurashtra region of Gujarat. The region receives approximately 500 mm average annual rainfall, lion’s share of which is received during the monsoon season (Mid – June to September). Due to the high year-to-year variation in the annual rainfalls, the region is heavily prone to droughts.

Over the past few years, local water harvesting and groundwater recharge have emerged as a major strategy in Saurashtra to mitigate the impact of the recurring droughts, which are manifested by severe shortage of water for irrigation and drinking, and fodder scarcity. Many NGOs in the region and government agencies had constructed nearly 1400 percolation tanks in the region. It is important to analyze the impacts of these interventions, before advocating them as a viable approach for addressing water scarcity, and drought proofing.

A study was undertaken to analyze the hydrological impacts of the local recharge. Sites were selected for detailed keeping in view the unique geological settings of the areas where these structures are located. Water levels in the percolation tanks, check dams, ASR wells, and surrounding observation wells were taken at 15-day intervals. Based on the data gathered, recharge rates and efficiency of percolation tanks are calculated. Based on the recharge rate estimates, performance indicators for the recharge systems were estimated. The paper presents the results of the study with regard to the following: [1] maximum rise in the water mound and the duration of rise; [2] radius of influence of percolation tanks; and [3] recharge rate and the recharge rate equation.

## 9.2 METHODOLOGY ADOPTED

- (1) Selection of suitable sites for recharge installations
- (2) Monitoring water levels of source area and observation wells falling under the influenced area.
- (3) Collection of evaporation data from nearby station.
- (4) Calculation of recharge rates from water level fluctuations and evaporation data.
- (5) Preparation of dimensionless graph to study nature of water mound developed.
- (6) Preparation of recharge rate graph and to find recharge rate equation from log – log graph.

## 9.3 PERCOLATION TANKS

### *General Introduction*

Four ponds have been selected for the study keeping in view the different geology and areas:

- (1) **Pichhvi Percolation Tank:** More than thousand percolation ponds have been constructed by NGOs in Saurashtra region for groundwater recharging. To represent the vastness of the whole scenario of the groundwater recharging by percolation tanks, a case study of Pichhvi percolation tank has been taken in detail. The evaporation and water level fluctuation data is collected from irrigation department.
- (2) **Hamirpura Percolation Tank:** With the observation of the results of the tank in 1998, Hamirpura Watershed Programme was developed for the Hamirpura and surrounding villages. With the use of bulldozers constantly for 15 days they have developed about 300 earthen bunds called para in local parlance. This is facilitating more percolation of water in ground, even if there is 30 cm of rainfall in a day.
- (3) **Shingoda Percolation Tank:** This village of Paddhari taluka is located at about 8 kms from Hamirpura. There is scarcity of drinking water in the village. The water works well of the village get dried up and as a result District Panchayat tankers have to supply water to the village during March, April, May. The tank is constructed in wasteland adjoining to water works well. In 1995, spillway portion has been constructed by using free stones available from village and cement of worth Rs.12,000. Every year in April-May, its desilting is done by people. While in adjoining Hamirpura village, the tank is not desilted. This tank has been selected and its monitoring is done to study the effect of silting on recharge rate.

## LOCATION, SOILS, TOPOGRAPHY AND GEOLOGY

**Table 9.1 Location, soils, topography and geology for percolation tank**

Sr. No.	Village Taluka District	Location		Soils/Topography	Geology	Remark
		Dist. Km	Latitude North Longitude East			
1.	Pichhvi Kodinar Amreli	20 100	20°59' 70°44'30"	Moderate salinity, clayey, montmorillonitic (calcareous), hyperthermic lithic ustochrepts. Very gently sloping coastal plain with moderate erosion	Miliolite limestone, 7 to 4m thick, hoighly carvencous in nature forms local aquifer. The quality of ground water is good.	Constructed by Govt. before 50 years renovated and desilted by Swadhyay Parivar in 1994.
2.	Hamirpura Morbi Rajkot	18 35	20°26' 70°35'	Clayey, montmorillonitic, hyperthermic lithic ustochrepts. Well drained, gently sloping, dissected alluvial plain with moderate erosion	Deccan trap of cretaceoecocene age volcanic in nature having thickness of 10 to 26 m. Below it compact trap is encountered.	Constructed by ORPAT in 1995
3.	Chhalla- Rupavati Dhrol Jamnagar	27 63	22°28' 70°27'	Moderate salinity, clayey, montmorillonitic (calcareous), hyperthermic lithic ustochrepts. Very gently sloping coastal plain with moderate erosion	Gaj limestone having thickness 10 to 20 m acts as a local aquifer	Constructed by Swadhyay Parivar in 1995. Desilting carried out every year
4.	Singhoda Padadhari Rajkot	8 32	22°25' 70°32'	Moderate salinity, clayey, montmorillonitic (calcareous), hyperthermic lithic ustochrepts. Very gently sloping coastal plain with moderate erosion	Deccan trap of cretaceoecocene age volcanic in nature having thickness of 8 to 20 m. Below it compact trap is encountered.	Constructed by Swadhyay Parivar in 1995. Desilting carried out every year

- (4) **Chhalla Rupavati Percolation Tank:** Population of the village is 1088. The work was started on 20/4/96 and was completed on 27/5/96. The construction involves earth work of total 30,500 cubic meters. As a result of this good quality of water is available in adjoining wells. Local stones available free of cost and cement of worth Rs.16,000 has been used for the work. Thirty-five tractors were engaged for 2092 hours.

#### ***Nature of Water Mound Development***

Taking reduced levels in the area of the tanks was the contour map of percolation tanks developed. With the help of the contour map area v.s elevation, volume stored v.s elevation and volume stored vs. area graphs were developed. Out of this the graphs of Hamirpura percolation tank is as follow:

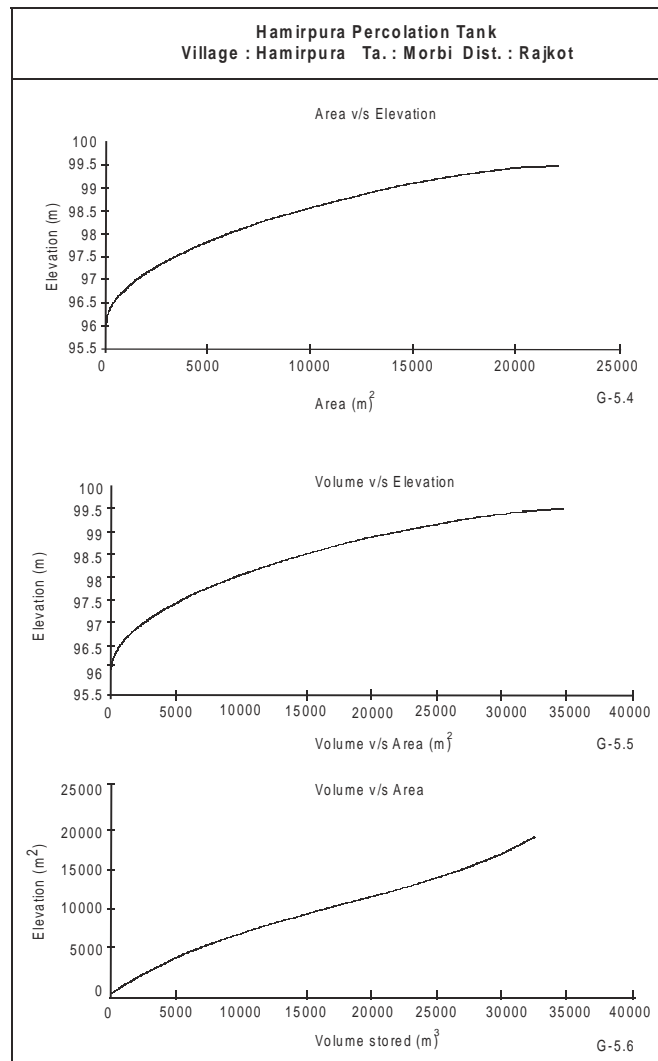

**Fig. 9.1** Graphs for Hamirpura percolation tank.

Water level fluctuation in the surrounding observation wells were observed continually at 15 day interval for a whole year and water mound and decay graphs were developed for all the ponds. Out of these for Hamirpura percolation tank is given in Fig. 9.2 as below:

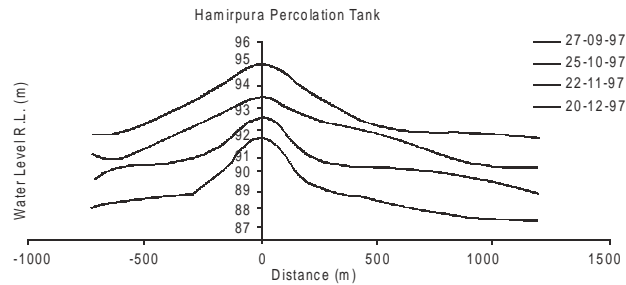

Fig. 9.2 Recharge mound development.

**Recharge Rate Calculation**

Water level fluctuations in recharge tanks were taken weekly continuously for two years from the water level difference total loss of water calculated. Out of this weekly evaporation deducted and cumulative recharge volume calculated. The water spread area according to water level calculated. From this recharge rate mm/day found out. The recharge rate graph of Hamirpura percolation tank is as shown in Fig. 9.3.

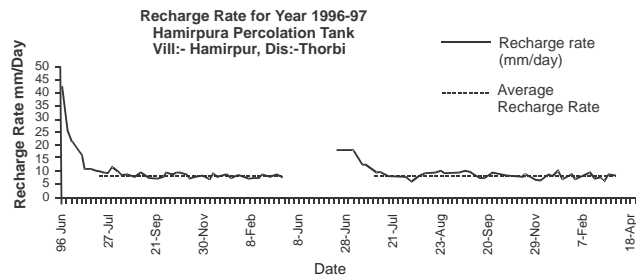

Fig. 9.3 Recharge rate graph.

To obtain the equation of recharge rate a graph of cumulative days vs. recharge rate was plotted on log – log graph paper for Hamirpura percolation tank as shown in Fig. 9.4a, b and c.

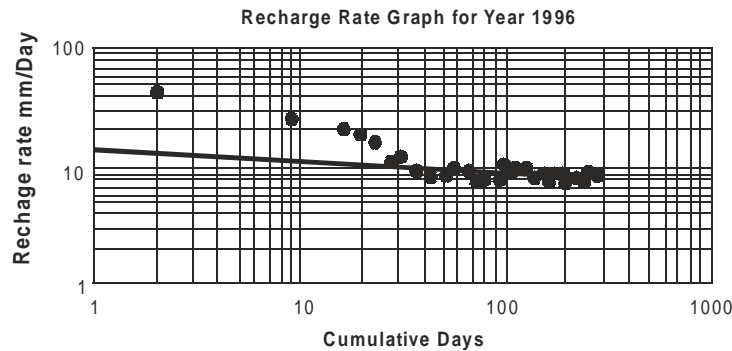
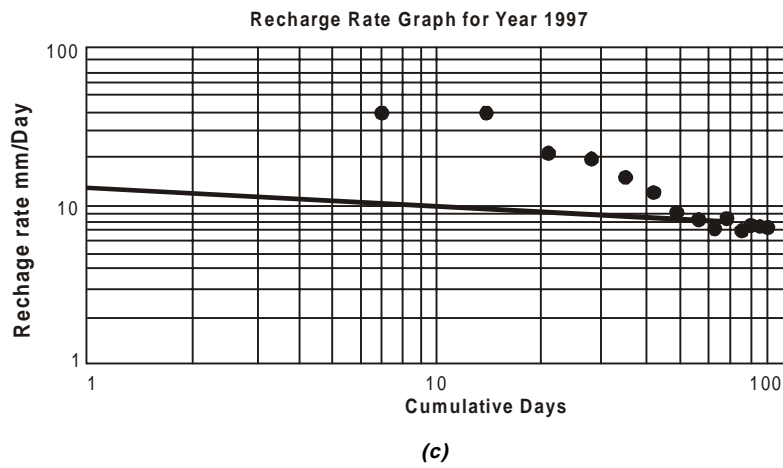
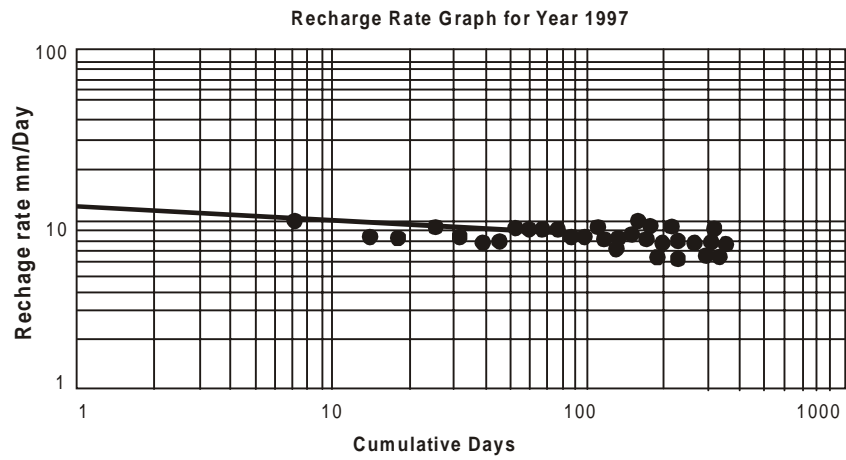

Fig. 9.4 (a)

Contd...



**Fig. 9.4** Graphs for recharge rate calculation.

**Rech. Rate formula**

Year	Intercept on Y Axis (REch. Rate) "α"	Slope of Graph $\beta = \frac{\text{Log } Y_2 - \text{Log } Y_1}{\text{Log } X_2 - \text{Log } X_1}$
1996	13	-0.09
1997	13	-0.114
1998	13	-0.13
Average	13	-0.111

So Rech. Rate Equaion

$$I = 13 T^{-0.111}$$

Where

I = Rech. Rate mm/Day

T = Time in Days

To have related idea of volume of water recharge and evaporation a graph is plotted as shown in Fig. 9.5. The volumetric efficiency is calculated in percentage by volume of recharge divided total volume loss.

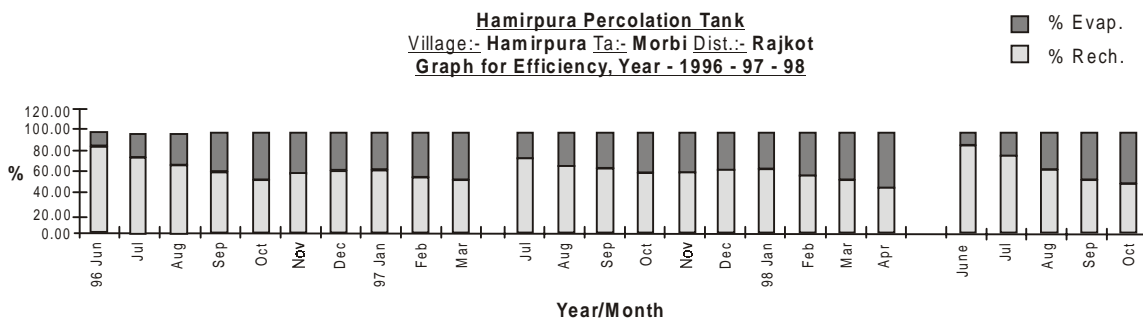

Fig. 9.5 Efficiency graph for the years 1996 - 97 - 98.

**Effect on Quality**

Water samples of surrounding wells were taken and analyzed. Total dissolved solids vs. distance of observation wells are plotted in (Figs. 9.6 a & b), showing clear cut reduction in TDS due to recharge.

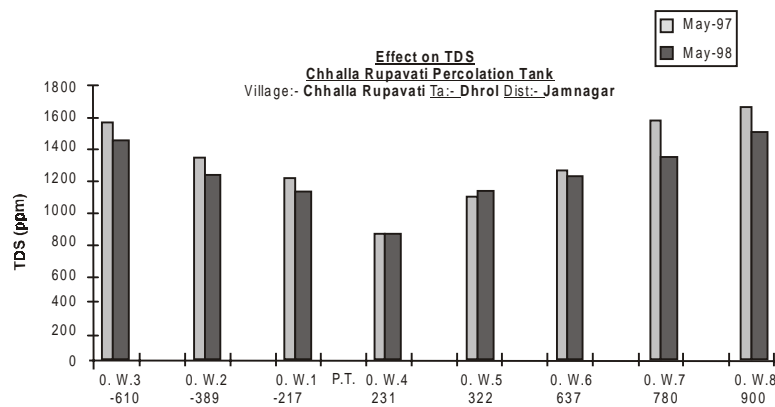
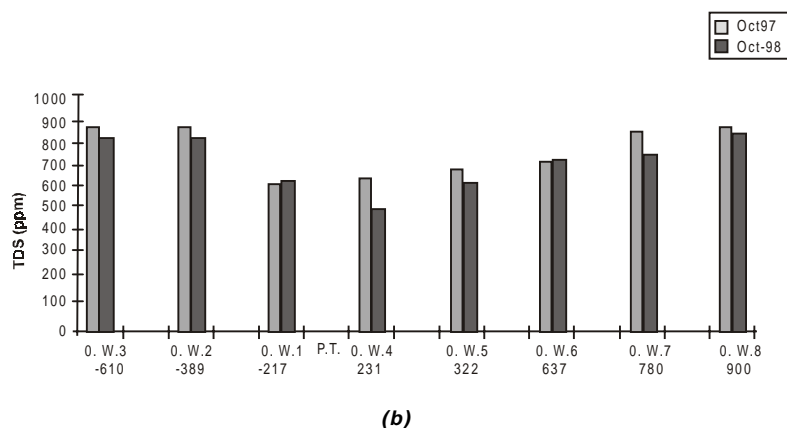

Fig. 9.6 (a)

Contd...



**Fig. 9.6 Effect of percolation tank on TDS.**

**Table 9.2 Maximum water mound rise at different distances in observation wells**

Name of Percolation Tank	Upstream Side (m)						Downstream Side (m)						
	200	400	600	800	1000	1200	200	400	600	800	1000	1200	1400
Pichhvi (Miliolite limestone, Desilted)	6.2	4.4	3.0	1.8	1	0	8	6.6	5.4	3.8	1	0.8	0
Hamirpura (Weathered basalt rock)	2.3	1.7	0.9	0	—	—	3	2.1	1.4	1.1	0.9	0	—
Chhalla Rupavati (Gaj limestone, Desilted)	4.45	3.05	1.45	0	—	—	5.1	3.9	3.2	0.9	0	—	—

**Table 9.3 Radius of influence and duration of water mound**

Name of Percolation Tank	Radius of Influence (m)		Duration of Water Mound (days)		Total Duration (days)	Duration of Water Stored in PT (days)
	U/S	D/S	Develop.	Decay		
Pichhvi (Miliolite limestone, Desilted)	1100	1300	165	100	265	270
Hamirpura (Weathered basalt rock)	720	1100	170	120	290	300
Chhalla Rupavati (Gaj limestone, Desilted)	780	1000	170	90	260	220



**Table 9.4 Recharge rate of percolation tanks**

Name of Percolation Tank	Recharge Rate (mm/day)									Average
	Maximum			Minimum			Yearly Average			
	1996	1997	1998	1996	1997	1998	1996	1997	1998	
Pichhvi (Miliolite limestone, Desilted)	95.84	74.29	—	27.46	26.86	—	30.05	30.0	—	30.02
Hamirpura (Weathered basalt rock)	43.1	18.0	39.76	7.0	6.28	6.85	8.0	7.8	7.8	7.87
Singhoda (Weathered basalt rock, Desilted)	29.71	34.29	36.43	17.57	18.57	20.57	18.5	20.7	22.0	20.40
Chhalla Rupavati (Gaj limestone, Desilted)	31.43	31.84	31.86	22.57	23.29	21.71	24.0	24.8	24.6	24.47

**Table 9.5 Recharge rate equations from log-log graph cumulative days v/s recharge rate**

Name of Percolation Tank	Intercept on y-axis (Recharge Rate), $\alpha$			Slope of Graph, $\beta$			Average		Equation
	1996	1997	1998	1996	1997	1998	$\alpha$	$\beta$	
Pichhvi (Miliolite limestone, Desilted)	78	95	—	-0.13	-0.12	—	86.5	-0.125	$I = 86.5 T^{0.125}$
Hamirpura (Weathered basalt rock)	13	13	13	-0.09	-0.114	-0.13	13	-0.111	$I = 13 T^{-0.111}$
Singhoda (Weathered basalt rock, Desilted)	38	39	27	-0.13	-0.11	-0.026	34.67	-0.089	$I = 34.67 T^{-0.089}$
Chhalla Rupavati (Gaj limestone, Desilted)	40	42	40	-0.11	-0.118	-0.11	41	-0.113	$I = 41 T^{-0.113}$

**Table 9.6 Comparison of efficiencies**

Name of Percolation Tank	Efficiency, %			Volumetric Efficiency, %			Average	
	1996	1997	1998	1996	1997	1998	Effi. %	Vol.Effi. %
Pichhvi	86.33	88.22	—	86.64	88.65	—	87.28	87.65
Hamirpura	63.41	58.70	68.25	63.43	58.72	68.22	63.45	63.46
Singhoda	79.44	81.00	81.12	79.41	80.96	81.12	80.52	80.50
Chhalla Rupavati	84.15	85.00	81.95	82.07	80.72	77.37	83.70	80.05

## 9.4 CHECK DAMS

### *General Introduction*

For the present study, five check dams have been presented.

- (a) Constructed by Government.
- (b) Tree lover Premjibhai initiated in one Upleta area.
- (c) Sutrapada check dam where sweet water is available in spite is surrounded by intruded sea water.
- (d) Sajan Timba check dam of Liliya taluka situated in high flouride content area.
- (e) A check dam constructed by Swadhyay Parivar in Mendarda taluka of Junagadh district.

**Chokli Check Dam:** Constructed in 1993 in Junagadh district and located at the distance of 2 kilometers from Rajkot-Junagadh highway. After seeing the results of this check dam, only in Mendarda taluka, 32 more check dams have been constructed. Since last 3 years at 10 every 15 days interval, water levels have been taken of the wells surrounding the check dam.

**Arnhi Check Dam:** This is one of the 135 check dams built in Upleta taluka.

**Sutrapada Check Dam:** This is located at distance of 2 kms from sea shore. The water in all the wells in the village is salty due to intrusion of sea water. Only the water in wells surrounding this check dam is sweet. Total population of the village is 18800. With the use of freely available limestone and using cement of Rs.12,000 — the spillover portion has been constructed. 217 members of 70 families have jointly worked for 27 days for the construction of this check dam.

**Bhiyal Check Dam:** The data taken here about the check dam constructed by Govt. is being collected and monitored. There is no desilting in this check dam. Therefore, there can be comparison of effects of silting in Chokli check dam of the same Mendarda taluka.

**Hathigadh-Khara Check Dam:** In Liliya taluka of Amreli district, there is huge problem of floride in water. There is no medicine of flourosis in medical science. In collaboration with Netherland Government, Government of Gujarat has developed a deflorination plant. But due to the problem of effluent disposal the plant is lying idle. This check dam has been selected with a purpose to study effects on fluoride of surrounding wells.

## LOCATION, SOILS, TOPOGRAPHY AND GEOLOGY

Table 9.7 Location, soils, topography and geology for check dams

Sr. No.	Village Taluka District	Dist. Km	Location		Soils / Topography	Geology	Remark
			Latitude North	Longitude East			
1.	Chokil Mendarda Junagadh	10 22	20° 0'30"	70°15'	Fine, montmorillonitic (calcareous) hyperthermic vertic ustochrepts. Moderately shallow, fine soil on very gently sloping alluvial plain (with mounds)	Deccan trap of cretaceoecocene age volcanic in nature having thickness of 7 to 26 m. Below it compact trap is encountered.	Constructed by Swadhyay Parivar in 1993. Desilting carried out every year
2.	Arnhi Uplete Rajkot	22 95	20°50'	70°10'10'	Clayey, montmorillonitic, (calcareous), hyperthermic, paralithic vertic ustochrepts. Well drained, gently sloping, dissected alluvial plain	Deccan trap of cretaceoecocene age volcanic in nature having thickness of 9 to 19 m. Below it compact trap is encountered.	Constructed by Premjibhai in 1996
3.	Sutrapada Veraval (Patan) Jamnagar	22 120	22°50'	70°20'	Fine, loamy, mix (calcareous), ustochrepts. typic ustochrepts. Well drained, fine clayey soils on very gently coastal plain	Miliolite limetone, 15 to 40 m depths are highly carvaneous in nature form, local aquifer Yielding saline quality of water.	3 km from Arabian sea cost constructed by Swadhyay Parivar
4.	Bhiyal Mendarda Junagadh	26 57	22°30'	71°20'	Fine, montmorillonitic (calcareous) hyperthermic vertic ustochrepts. Moderately shallow, fine soils on fine soils on very	Miliolite limestone, 12 to 20 m depths are highly carvaneous in nature forms local aquifer. Yielding saline quality of water. gently sloping alluvial plain (with mounds)	Constructed by Governmet on tributary of Madhuvanti river
5.	Hathigadh- Kahra Leliya Amreli	10 57	22°45'	71°29'	Fine, montmorillonitic (calcareous), hyperthermic typic chromusterts. Moderately drained, fine soils, on gently sloping ground plains with slight salinity	Deccan trap of cretaceoecocene of 15 to 20 m depth becomes compact at depth having max. depth more than 150 m contains fluoride contents	Constructed by Swadhyay Parivar

### Recharge Rate

A survey was conducted to find out reduced level in and around check dams and contour maps were prepared. From the contour map graphs of cross sectional distance vs. elevation were prepared. Cross-section areas at different distances were also plotted and area of each cross-section were found out, from which average area is calculated. A table of reduced levels and corresponding cross-section area, width, perimeter, water spread distances from check dam were tabulated. With the help of these tables and weekly observations at check dams the total water loss and evaporation was found out from this wetted area and recharge rate were calculated. The equations of the recharge rate were found out in similar way as done for the percolation tanks.

### Water Mound Development and Decay

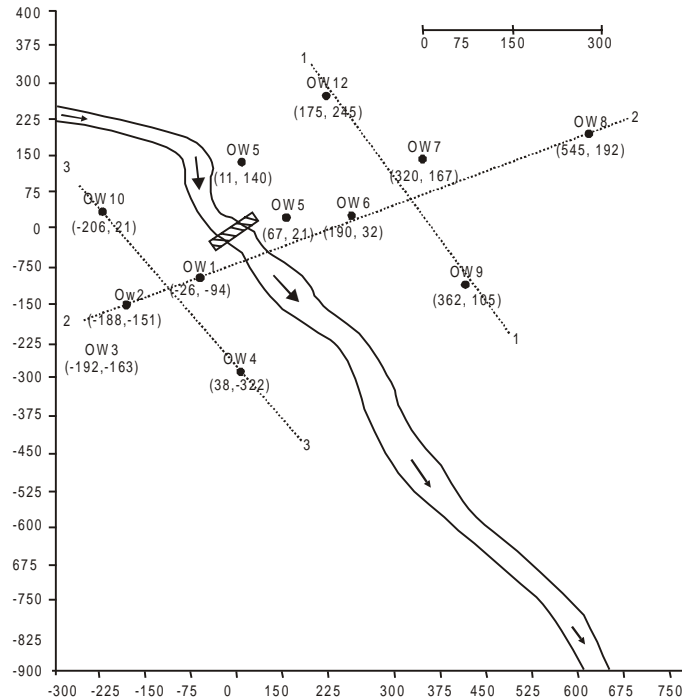

Fig. 9.7 Location of observation wells for Chokli check dam.

Water level fluctuations in 12 observations wells for 2 years were observed and reduced water level was calculated. Water level maps for water mound rise and decay were prepared and were plotted for 3 cross-sections as shown below.

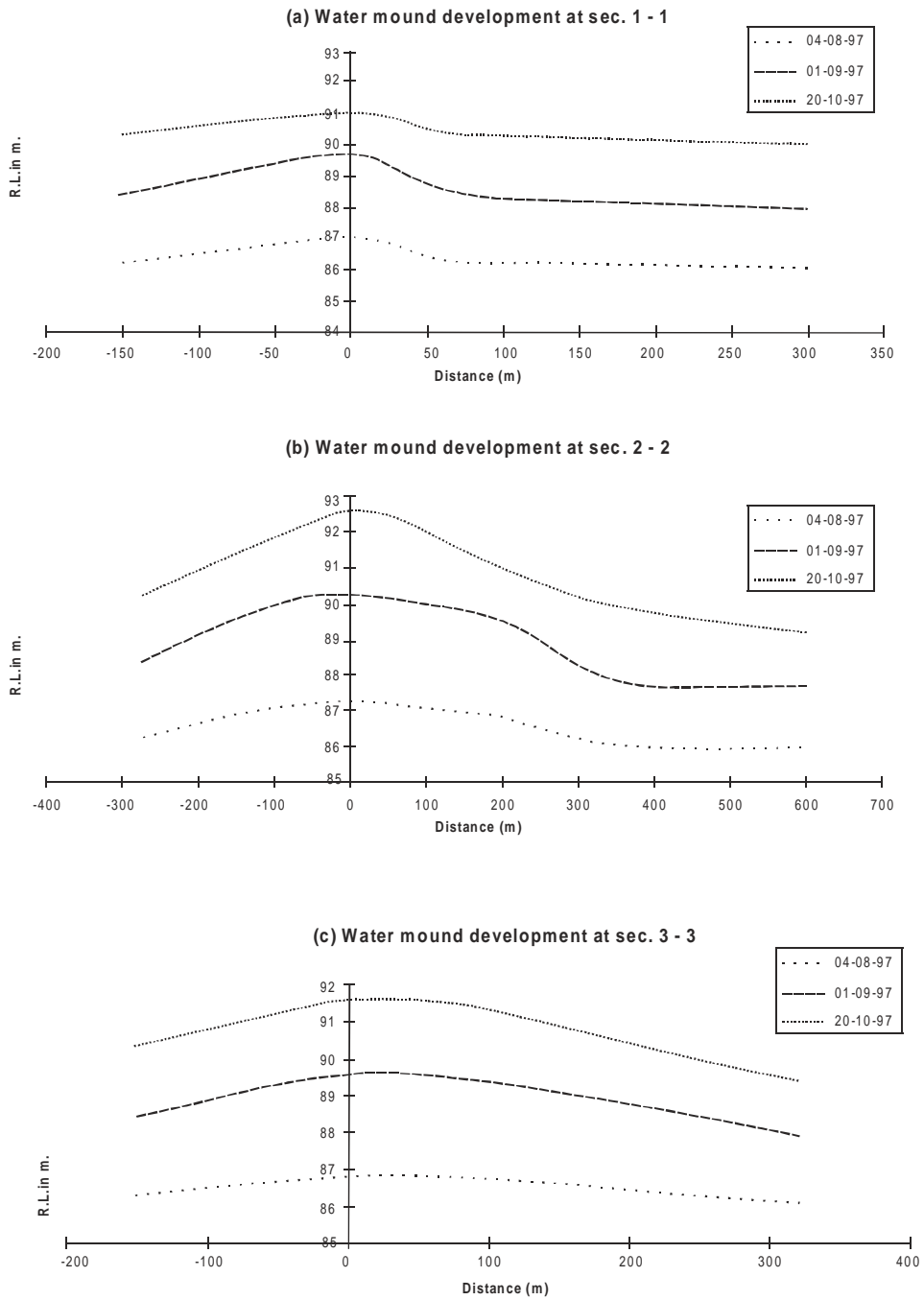
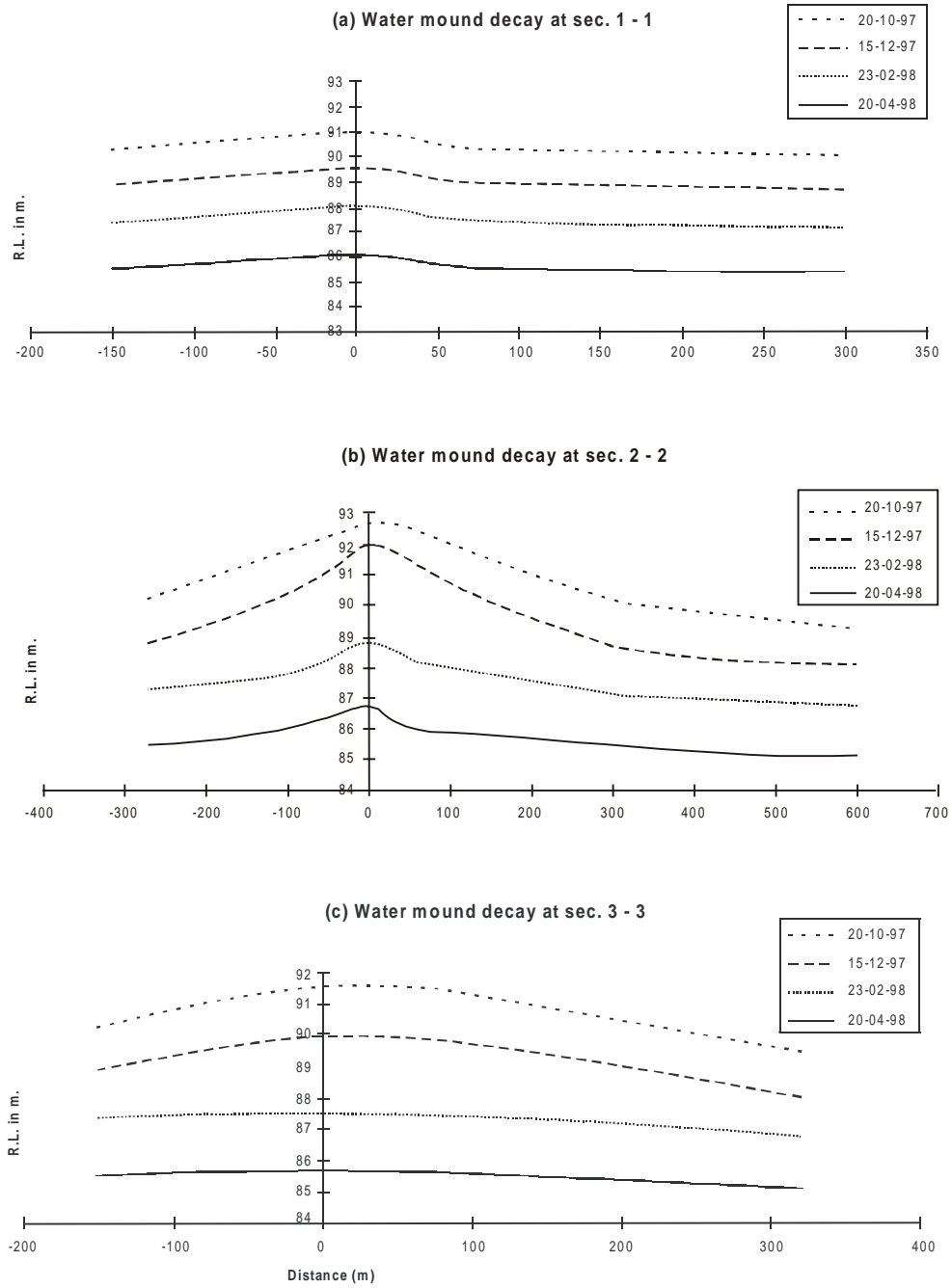

Fig. 9.7 a, b c Water mound development graphs for Chokli check dam.



**Fig. 9.8 a, b, c Water mound decay graphs for Chokli check dam.**

**Recharge Effect on Water Quality**

**[A] Effect on TDS**

From water analysis reports graphs for April 97, and Oct. 97, 98 were prepared to show the effect on TDS for Sutrapada check dam. Similarly for Hathigadh Khara check dam graphs were prepared.

**[B] Effect on Fluorides**

Hathigadh Khara check dam is in fluoride affected area. From water analysis report all the parameters except fluoride were within water limit. Water is unfit for potable use only due to fluoride content more than 1.5 ppm to study the effect of recharge on fluoride graphs was prepared.

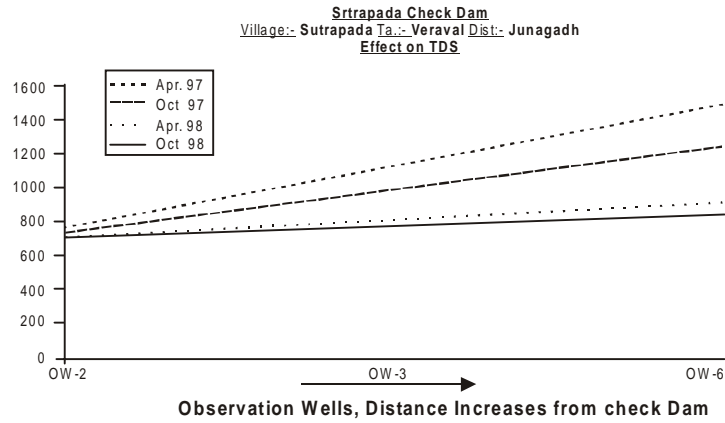

**Fig. 9.9 Effect of recharge on TDS for Sutrapada check dam.**

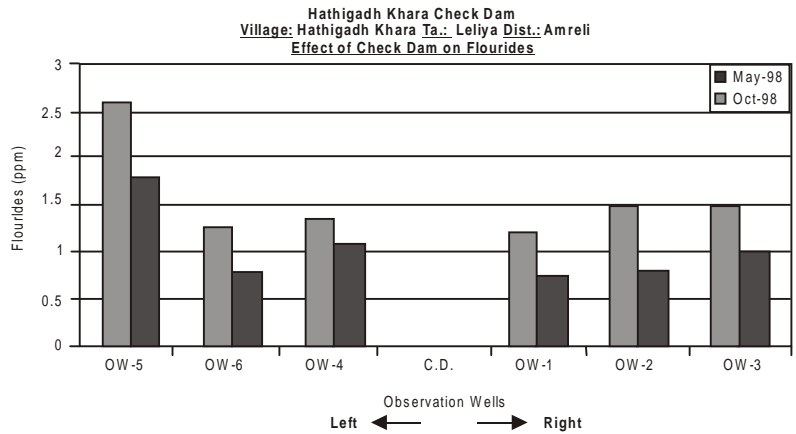

**Fig. 9.10 Effect of recharge on fluoride for Hathigadh Khara check dam.**

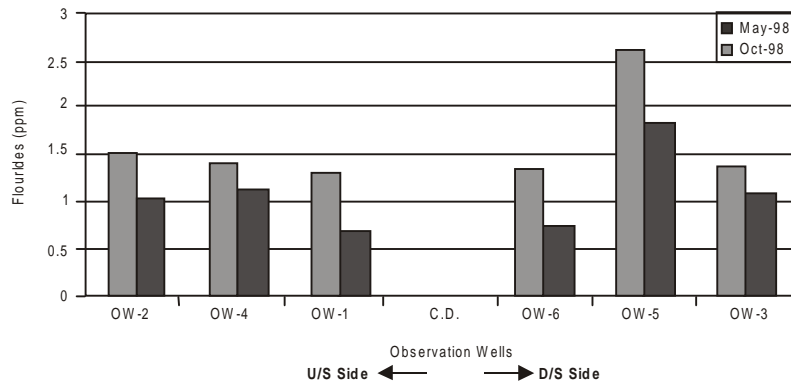

Fig. 9.11 Effect of recharge on fluoride on upstream and downstream.

**Results of Check Dams**

**Effect of Check Dam on Surrounding Wells**

**Table 9.8 Maximum water mound rise at different distances in observation wells for Chokli check dam (1996 - 98)**

Dist. from CD (m)	Upstream Side (m)				Downstream Side (m)					
	150	200	300	400	100	150	200	300	400	500
Mound Height developed (m)	1.2	1.1	0.87	0.1	4.2	4.0	3.6	1.5	0.5	0.2

Radius of Influence on upstream is 430 m and on down stream 550 m

**Table 9.9 Recharge rate of check dams**

Name of Check Dam	Recharge Rate, Mm/day									Overall Avg.
	Maximum			Minimum			Average			
	1996	1997	1998	1996	1997	1998	1996	1997	1998	
Chokli (weathered basalt rock, desilted)	113.84	62.49	69.23	39.18	26.85	26.28	55.19	44.85	43.79	47.94
Arnhi (weathered basalt rock,)	38.54	41.73	38.82	22.25	20.23	18.74	29.17	30.98	30.0	30.05
Bhiyal (weathered basalt rock, )	44.9	45.8	61.5	38.2	34.7	27.2	40.2	38.82	24.9	34.64

**Table 9.10 Recharge rate equations from log-log graph cumulative days v/s recharge rate**

Name of Check Dam	Intercept on y-axis (Recharge Rate), $\alpha$			Slope of Graph, $\beta$			Average		Equation
	1996	1997	1998	1996	1997	1998	$\alpha$	$\beta$	
Chokli	70	68	64	-0.10	-0.92	-0.065	67.33	-0.086	$I = 67.33 T^{0.086}$
Arnhi	60	58	55	-0.261	-0.183	-0.171	57.67	-0.205	$I = 57.67 T^{-0.205}$
Bhiyal	41	43	65	-0.022	-0.031	-0.18	49.66	-0.078	$I = 49.66 T^{-0.078}$



**Table 9.11 Comparison of recharge and evaporation volumes**

Name of Check Dam	Recharge Volume m <sup>3</sup> /season			Evaporation Volume m <sup>3</sup> /season			Average m <sup>3</sup> /season		Ratio VR/VE
	96-97	97-98	98-99	96-97	97-98	98-99	Rech. Vol.	Evap. Vol.	
Chokli	17015	16783	16593	5235	5553	5564	16797	5451	3.08
Arnhi	7009	11421	21029	3002	4731	8144	13153	5292	2.48
Bhiyal	16414	16024	14702	6856	6272	5947	15713	6358	2.47

**Table 9.12 Comparison of efficiencies**

Name of Check Dam	Efficiency, %			Volumetric Efficiency, %			Average	
	1996	1997	1998	1996	1997	1998	Effi. %	Vol.Effi. %
Chokli	91.56	89.95	89.33	90.23	90.36	89.98	90.28	90.19
Arnhi	82.64	84.29	78.39	81.98	82.05	78.69	81.77	80.90
Bhiyal	85.10	85.47	80.92	89.84	88.80	86.60	83.83	88.41

## 9.5 AQUIFER STORAGE RECOVERY (A.S.R.) WELLS

In this section, data collection of recharge wells and some other structures constructed by Gujarat Government for preventing salinity ingress are included.

More than 5,00,000 wells are drawing water from unconfined aquifer in Saurashtra peninsular region. Due to overexploitation of aquifer, water table goes below and quality of water deteriorated considerably. As a result many wells become abandoned and sea water intrusion advances nearly 1 km inland. The coastal area of Saurashtra is 900 km<sup>2</sup> long i.e. every year 900 km<sup>2</sup> land faces the problem of sea water intrusion. The area between Una and Madhavpur was known as Lilee Nager due to greenery. Now the same soil has become saline.

In 1993, some farmers of this area recharged their open wells from storm water runoff in monsoon or by diverting water from stream, river or pond into wells. By observing good results, many farmers come forward to recharge their wells. The thought spread like a fire and more than one lakh wells are recharged upto 1998.

Here four cases are selected for data collection and analysis.

- (1) A well recharged from farm runoff at Khadvanthli.
- (2) A well recharged from the reservoir created by a check dam constructed on Madhuvanti River at Mithapur.
- (3) A well in Goraj village of Mangrol taluka, where Warabandhi for recharging wells is practiced.
- (4) A well in floride affected area village Sajantimba, Ta : Leliya or Amreli district.

All these wells are irrigation wells. They are recharged when water is surplus in monsoon (July, Aug, Sept) and water is withdrawn during needy period. So these wells are called A.S.R.

(Aquifer Storage Recovery) wells. As they are dual purpose wells, due to surveying and desilting effect, their discharging rate is not reduced considerably. The quality of water is improved which improves the quality of soils also. As a result, so many farmers have earned additional income of Rs.20,000 per annum each.

***Mithapur A.S.R. Well*** :This village is on bank of Madhuvanti river. One farmer has laid a pipe line by excavating more than 8.0m average in rocky area (by help of explosive) and recharged his well. The district panchayat has constructed one check dam in upper region. The well gets recharged upto the month of February from this reservoir. Due to this recharge the quality and water level of surrounding wells are also improved considerably. Formally the well becomes dry in the month of February. Now water is available throughout the year and farmer is able to take three crops in a year.

***Goraj A.S.R. Well***: This village is just 8 km from Arabian sea coast. More than 200 dug wells are constructed by farmers. Nearly all are recharged in monsoon. In the well under study, water is diverted from tributary of river. The porosity of calcareous lime stone in this region is high. As a result intake capacity of well is excellent so farmers have agreed for Warabandhi for diverting stream water into wells. Warabandhi for recharging wells might have been practiced for the first time in the world.

***Sajantimba A.R.S. Well***: This village is in Liliya taluka, a fluoride-affected area of Amreli district. To study the effect of recharge on fluoride, water analysis of surrounding and recharge wells are collected and analysed in water supply and sewage board laboratory at Bhavnagar.

## LOCATION, SOILS, TOPOGRAPHY AND GEOLOGY

Table 9.13 Location, soils, topography and geology for A.S.R. wells

Sr. No.	Village Taluka District	Dist. Km	Location		Soils/Topography	Geology	Remark
			Latitude North	Longitude East			
1.	Khadvanthil Gondal Rajkot	23 55	22° 0'30"	70°30'	Clayey, montmorillonitic (calcareous), hyperthermic paralithic vertic ustochrepts. Very gently sloping dissected alluvial plain with moderate erosion	Deccan trap of cretaceoecocene age volcanic in nature having thickness of 9 to 20 m. Below it compact trap is encountered.	An ope well recharge from farm runoff since 1993
2.	Mithapur Mendarda Junagadh	12 43	21°30'	70°20'	Clayey, montmorillonitic, (calcareous), hyperthermic, paralithic vertic ustochrepts. Well drained, gently sloping, dissected alluvial plain	Deccan trap of cretaceoecocene age volcanic in nature having thickness of 8 to 25 m. Below it compact trap is encountered.	A well recharge from the river Madhuvanti directly by laying 30 cm dia. pipeline
3.	Goraj Mangrol  Jamnagar	8  64	21°15'	70°0' 30"	Fine, loamy, mix (calcareous), ustochrepts. typic ustochrepts. Well drained, fine clayey soils on very gently coastal plain	Miliolite limetone, 10 to 45 m depths are highly carveneous in nature form, local aquifer Yielding saline quality of water.	Warabandhi for recharging wells form strom water drains.
4.	Sajantimba Lilya Amreli	10 57	21°48'	71°27'	Fine, montmorillonitic (calcareous) hyperthermic vertic ustochrepts. Moderately shallow, fine soils onfine soils on very gently sloping alluvial plain (with mounds)	Decan trap of creataceoecocene of 15 to 20 m depth becomes compact at depth having max. depth more than 150 m contains fluoride contents	Located on tributory of Shetrunji river. Fluoride affected area.

**Study of Water Level Fluctuations in ASR & Observation Wells**

To study the nature of water level fluctuations a graph date vs. water level R.L. is plotted for Khadvanthalı A.S.R. wells. To study the cumulative effect premonsoon and postmonsoon (May, Oct.) vs. water depth in well graph is plotted for three years.

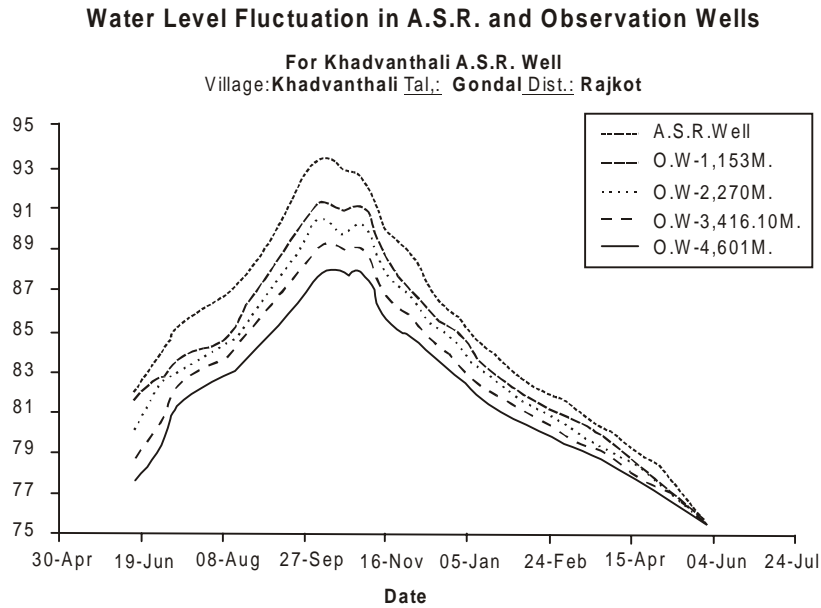

**Fig. 9.12** Water level fluctuation in Khadvanthalı ASR well.

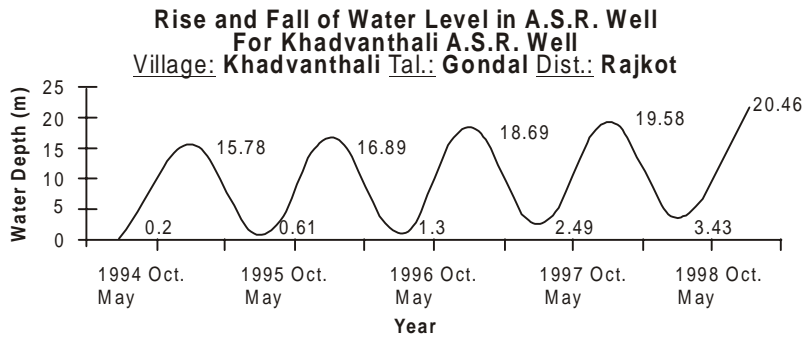

**Note: Well is Recharged Since 1993**

**Fig. 9.13** Water level fluctuation from 1994 – 98 in Khadvanthalı ASR well.

**Nature of Water Mound**

To study the effect of water recharge on surrounding wells, a water mound development and decay graphs were plotted for Khadvanthalı A.S.R. well.

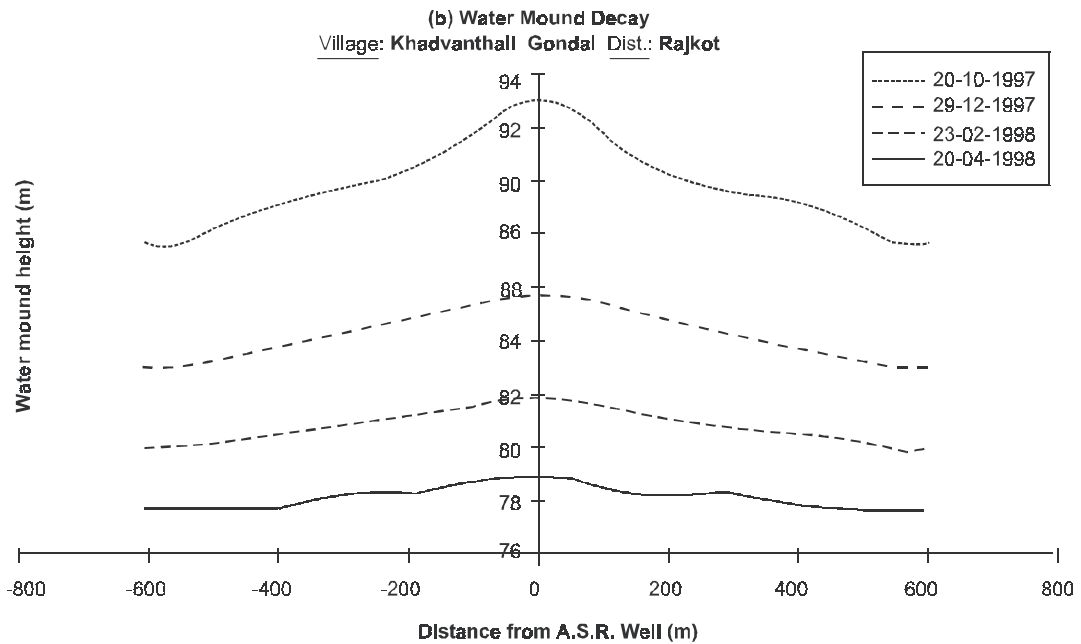
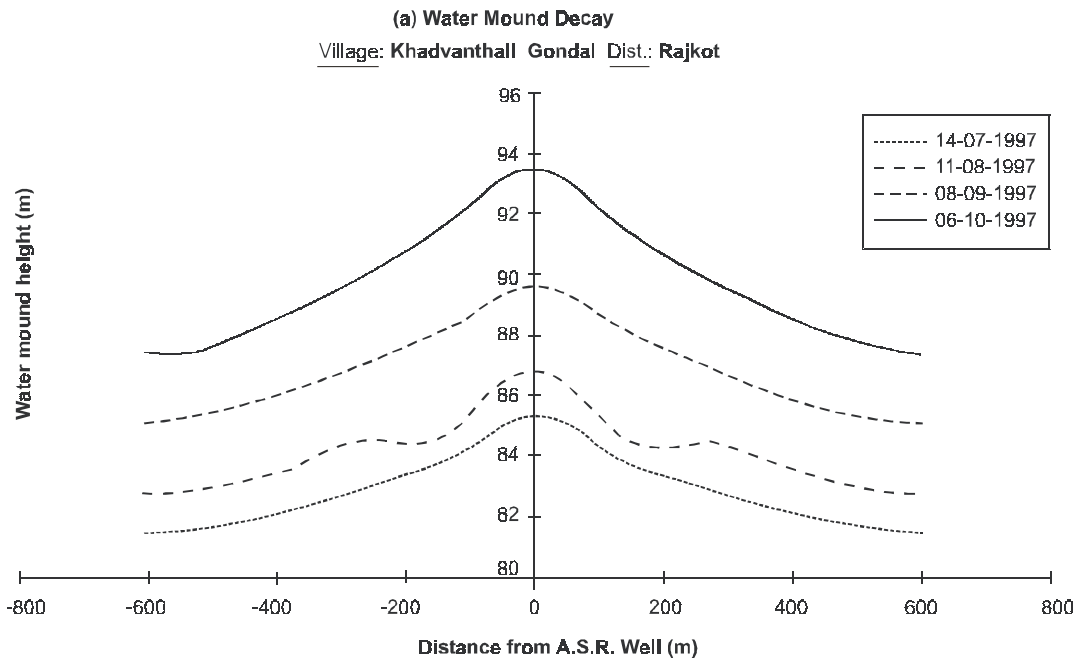
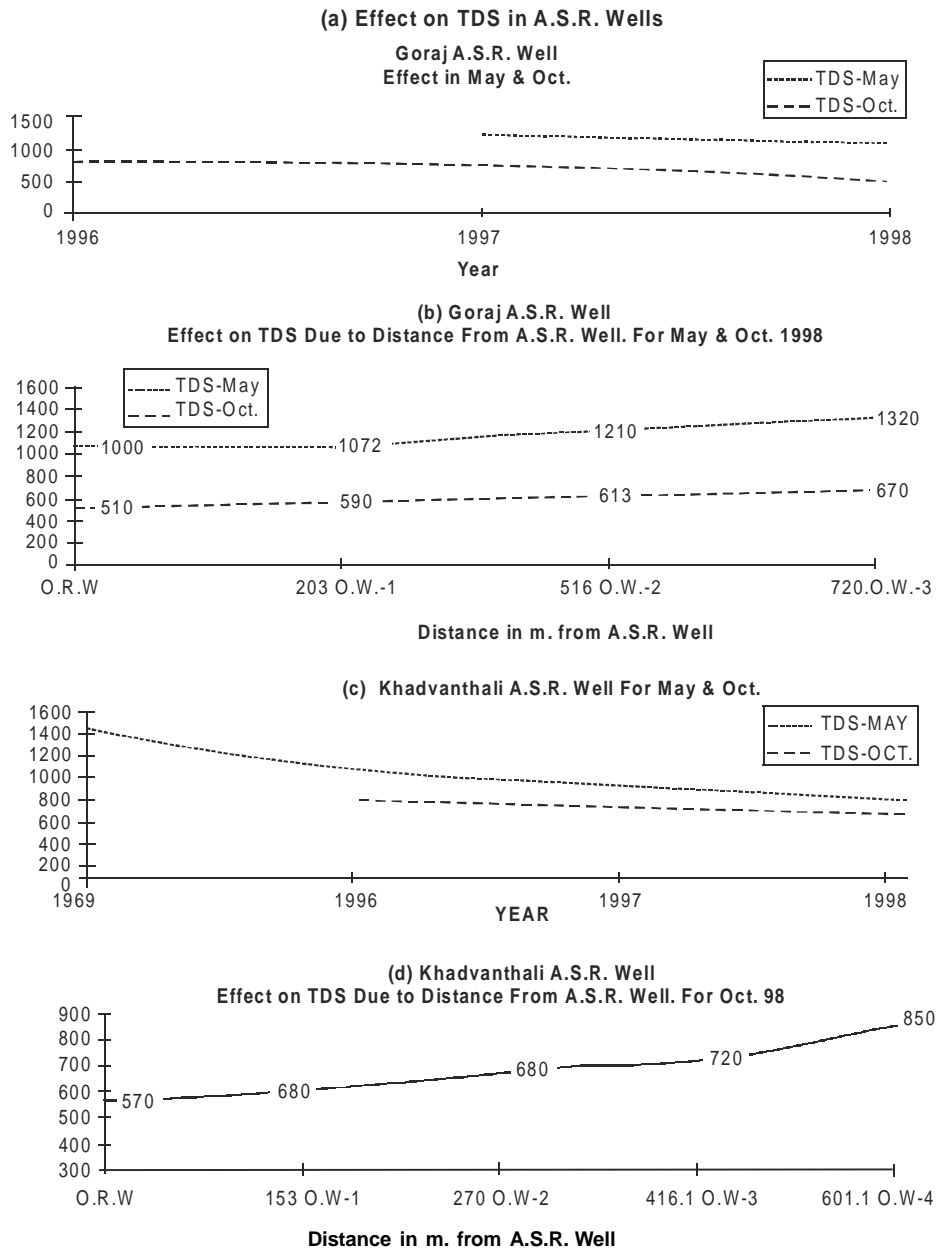

Fig. 9.14 a, b Water mound development in Khadvanthali ASR well.

**Effect on Water Quality**

**[A] Effect on T.D.S.**

To study the effect of recharge on water quality, water quality analysis report for two wells one in weather basalt rock (Khadvanthli) and other in miliolite limestone (Goraj) were used to plot the graphs.



**Fig. 9.15 a, b, c, d Effect of recharge on water quality.**

**[B] Effect on Fluoride**

To study the effect of recharge in fluoride affected area Sajantimba A.S.R. well was selected and graphs were plotted.

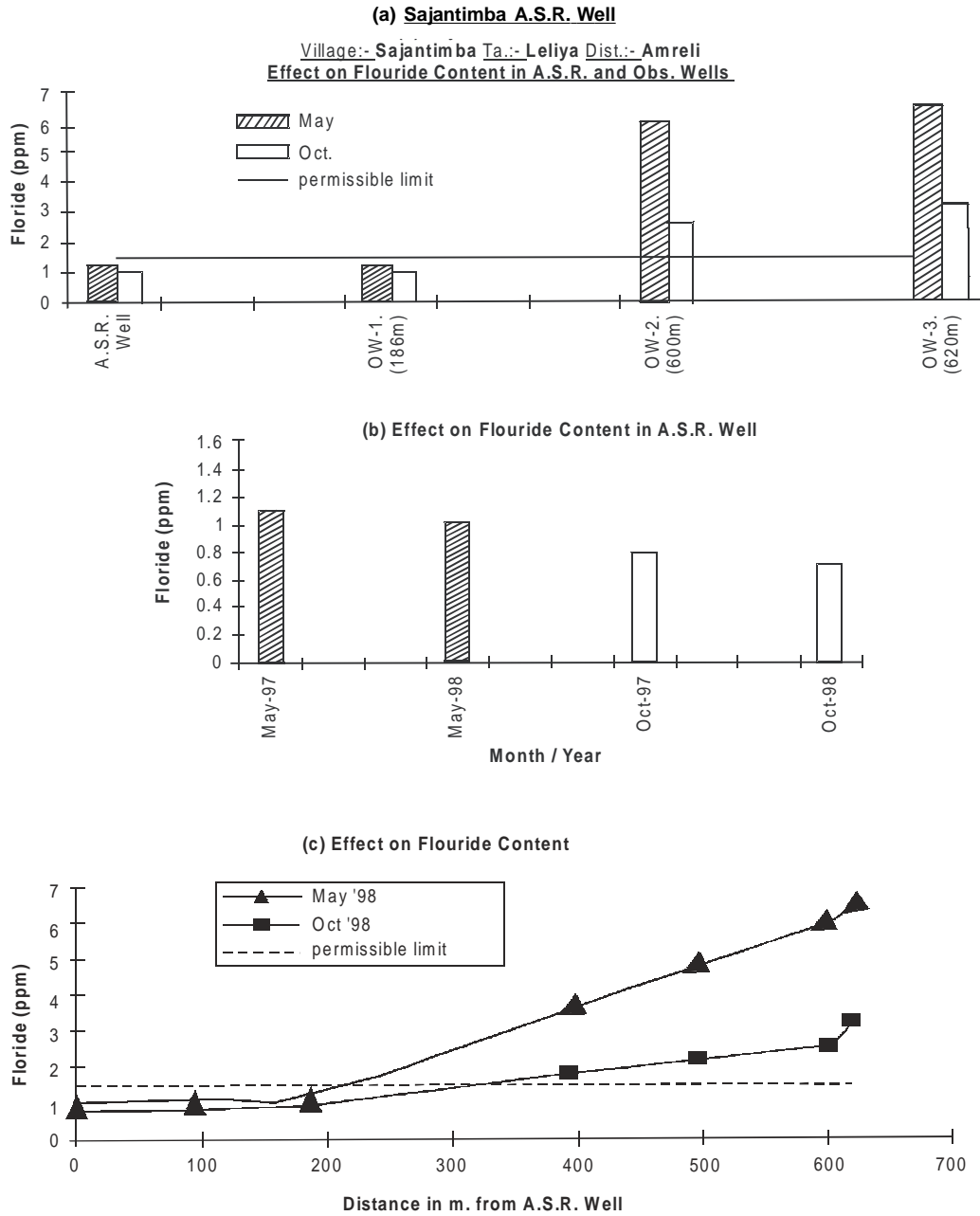

Fig. 9.16 a, b, c Effect of recharge on fluoride in Sajantimba ASR well.

### Results of Aquifer Storage Recovery Wells

#### Development of Water Mound

Table 9.14 Development of water mound

Name of Well	Height of Water Mound		Radius of Influence, m	Period of Development, days	Period of Decay, Days	Month of Max. Height
	1997	1998				
Khadvanthali	6.13	6.03	570	120	220	Middle Oct.
Goraj	8.67	8.14	530	100	200	Middle Nov.

#### Summary of Results

From the foregoing discussion, following conclusions emerge.

- (i) The height of water mound developed in A.S.R. wells in miliolite limestone is 8.4 m as compared to A.S.R. wells in weathered trap 6.1 m but radius of influence are 530 m and 570 m and period of development of water mound is 100 days and 120 days whereas period for decay is 200 and 220 days, respectively indicating miliolite limestone greater permeability. Water mound height in limestone is higher but less life period.
- (ii) Silting in percolation tanks and check dams not only decreases the storage capacity but also reduces recharge rate as seen from following results.

	Average Rech. Rate, Mm/day	Recharge Rate Equations	Vol. of Rech./ Vol. of Evapo.
Normal Percolation Tank	7.87	$I = 13 T^{-0.111}$	1.83
Desilted Percolation Tank	20.40	$I = 34.67 T^{-0.089}$	4.20
Normal Check Dam	30.05	$I = 57.67 T^{-0.205}$	2.48
Desilted Check Dam	47.94	$I = 67.33 T^{-0.086}$	3.08

- (iii) Recharge structures have effect upto greater extent on downstream as compared to upstream as seen from following results.

		Radius of Influence	
		U/S	D/S
Percolation Tank	Miliolite limestone	1100	1300
	Gaj limestone	780	1000
	Weathered basalt rock	720	1100
Check Dam	Weathered basalt rock	430	550

- (iv) The T.D.S. values, which is a quality parameter is remarkably less at the vicinity of recharge structure and increases alongwith the distance of the structure. This is due to dilution caused by recharge.
- (v) Monitoring one check dam and one aquifer storage recovery well in flouride contaminated area indicated a significant decrease in flouride content, which proves that recharge methods are effective in reducing effects of flouride.



- (vi) The values of linear and volumetric efficiencies are nearly the same for all percolation tanks and check dams. This can also be taken as performance indicator of successful recharge effort.
- (vii) The percolation tanks and check dams are said to be successful if the efficiency is more than 70 % and said to be effective if it is more than 80 %.
- (viii) The desilted percolation tanks and check dams have very long life, it can not be predicted but the life of percolation tanks and check dams is 6 to 7 years. So it is better to desilt the existing percolation tanks and check dams than to construct new one.
- (ix) Recharge rate is maximum (30.25 mm/day) in miliolite limestone, medium (24.47 mm/day) in Gaj limestone and minimum (20.40 mm/day) in weathered basalt rock.

Recharge rate equations for percolation tank are

$$I = 86.5 T^{-0.125} \text{ for miliolite limestone}$$

$$I = 41 T^{-0.113} \text{ for Gaj limestone}$$

$$I = 34.67 T^{-0.89} \text{ for weathered basalt rock}$$

This indicates recharge structures are more effective in miliolite limestone.

From the above, one can deduce that for success of any recharge structures in Saurashtra region following serves as the performance indicators.

- (a) Height of water mound formed
- (b) Areal extent of water spread both upstream and downstream of the structure.
- (c) Linear and volumetric efficiency
- (d) Water quality parameters such as TDS and Flouride
- (e) Management of recharge structure

Given a scenario like Saurashtra, it is needless to say that though the water is trapped in an unconfined aquifer, it is only through the recharge efforts; water is made available in difficult periods either during a draught cycle or in summer. This itself speaks volumes of the recharge efforts put in by the people of Saurashtra.

# 10 SEA WATER INTRUSIONS

## 10.1 INTRODUCTION

At present, 6 out of 10 people live within 60 km of the coast and by the end of 2020 more than two-third of the population of developing countries, i.e. around 4,000 million people, will live in the vicinity of the sea. For ages, mankind is attracted to these areas because of the availability of an abundance of food (e.g., fisheries and agriculture) and the presence of economic activities (e.g., trade, harbors, ports and infrastructure). Due to increasing concentration of human settlements, agricultural development and economic activities, the shortage of fresh groundwater for domestic, agricultural, and industrial purposes becomes more striking in these coastal zones, resulting in seawater intrusion and related deterioration of the water quality.

During the latter part of 20<sup>th</sup> century there has been a widespread increase in urbanization. As many major cities in the developing world are situated on the coast, and many lie on unconsolidated aquifers, this has placed increasing importance on coastal unconsolidated aquifers for water supply. As little as 2% seawater in freshwater can render the water non-potable, and saline water has been reported to be the most common pollutant in fresh groundwater (Todd (1980)). The problem of seawater intrusion requires the application of specific management techniques.

The term sea water intrusion specifically describes the situation where modern seawater displaces, or mixes with, freshwater within an aquifer in response to a change in the hydro-geological environment. The expression is, however, frequently used to describe any case where waterbodies of differing salinities occupy the same aquifer system. The most common processes responsible of salinization in coastal aquifers are:

- 1) Present-day (active) seawater intrusion due to overpumping and upward displacement of the freshwater-saline interface.
- 2) In the case of confined aquifers, the natural geochemical evolution of groundwater along a particular flow-path may result in a progressive increase of salinity. If the aquifer is made of partly flushed marine sediments, groundwater may acquire a chemical signature (either sodium chloride or calcium chloride facies) similar to the observed trend in the case of seawater intrusion. Refreshing of aquifers may lead to important.

- 3) Changes in water chemistry due to cation exchange in coastal aquifers (Appelo and Postma, 1994).
- 4) Dissolution by groundwater of evaporitic minerals interbedded in the stratigraphic column. Intense pumping may force groundwater leaching of low permeability horizons containing soluble salts.
- 5) Upward leakage from a deeper confined aquifer into a shallow phreatic water-bearing horizon may also result in a marked increase of salinity.
- 6) Irrigation returns flow or infiltration of industrial wastewaters or sewage.
- 7) Infiltration from estuaries or artificial canals containing brackish waters. In this case, three different water types may be interacting in the aquifer.
- 8) Presence of connate, trapped brines or brackish waters mixed in different proportions with shallow groundwater.
- 9) Incorporation of sea salt spray into infiltrating waters in the soil layer.

In the simple case of direct seawater intrusion or a simply mixture of two water types, the mixing proportions of the two end-members (e.g. seawater and fresh groundwater or river water from an estuary) can be derived from a simple linear relationship. This approach can be followed using a series of physical, chemical or isotopic parameters, as long as there is sufficient contrast (in the chemical or isotopic contents) between the two types of waters, and the parameters are conservative. Among these parameters, the most commonly used are: electrical conductivity, chloride, bromide, sodium, oxygen- 18, deuterium, etc.

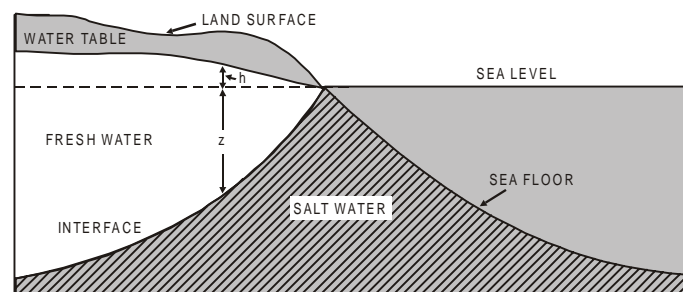

**Fig. 10.1** Simplified freshwater-saltwater interface in a coastal water-table aquifer.

Already at this moment, many coastal aquifers in the world, especially shallow ones, experience an intensive salt water intrusion caused by both natural as well as man-induced processes (Oude Essink, 2000a).

Human interferences, such as mining of natural resources (water, sand, oil and gas) and land reclamation (causing subsidence) threaten coastal lowlands. Consequently, salinities of surface water systems increase and land degradation occurs because soils become more saline. As a result, poor crop yields are produced due to salt damage and indigenous crops might be substituted by more salt-tolerant crops. If even the salt-tolerant

crops cannot withstand the high salinities, the population might eventually migrate from the barren land and resettle in more fertile arable territories, which could cause social commotions. In addition, coastal aquifers within the zone of influence of mean sea level (M.S.L.), are threatened by an accelerated rise in global mean sea level. This rise in global mean sea level, 50 cm for the coming century as the present best estimate, could even more jeopardize vulnerable coastal aquifers than they are threatened today. Subsequently, the salinization of coastal aquifers will accelerate. This could mean a reduction of fresh groundwater resources. In addition, the present capacity of the discharge systems in several coastal lowlands may be insufficient to cope with the excess of seepage water, especially in those coastal areas, which are below M.S.L. This seepage will probably have a higher salinity than at present.

## 10.2 CAUSES OF SEA WATER INTRUSION

Sea water intrusion is caused primarily by the reduction of fresh water discharge to the sea as a result of groundwater abstraction. The water is derived from one of the three sources: drainage from the water table; release from elastic storage; and drainage at the seawater/fresh water interface, where fresh water is replaced by salt water (Essaid, 1986). The salt-water wedge consequently moves inland, flushing decreases, and the thickness of the wedge increases. If some fresh water flow is maintained at the coast, a new equilibrium eventually develops.

Groundwater abstraction above the interface causes up-coning. Depending on aquifer characteristics, well penetration, and pumping rate, a stable situation may be attained, where salt water does not reach the well. However, when this critical state is exceeded, salt water enters the well, mixes with the fresh water, and the quality of the discharge decreases.

Abstraction is not the only control on the position of the saline water/freshwater interface. A number of other factors can affect its position including:

- 1) Seasonal changes in natural groundwater flow
- 2) Tidal effects
- 3) Barometric pressure
- 4) Seismic waves
- 5) Dispersion
- 6) Climate change — global warming and associated sea level rise.

Some of these have short-term implications (tidal effects and barometric pressure) some are periodic (seasonal changes in groundwater flow) and others are long term (climate change and artificial influences).

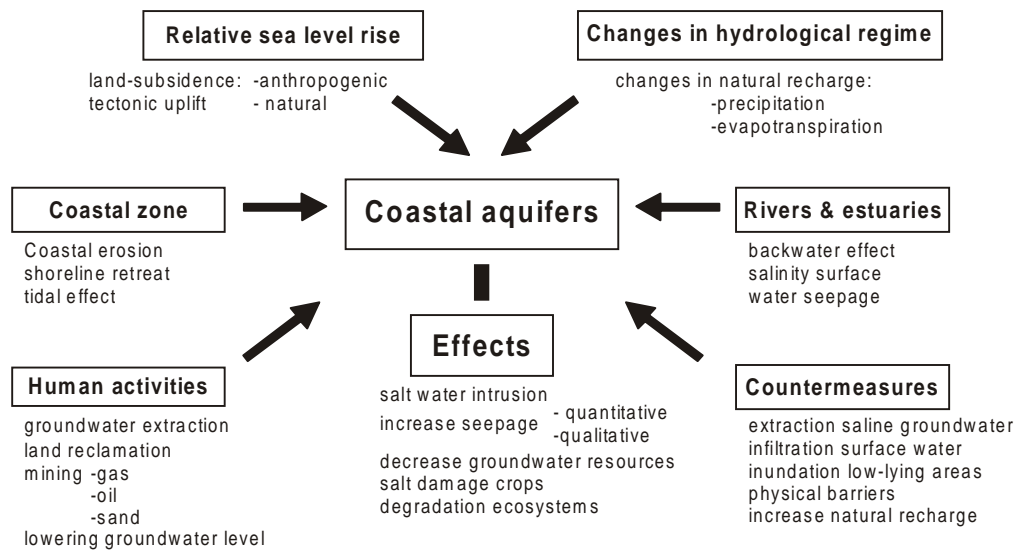

Fig. 10.2 Factors affecting coastal aquifers.

The present distribution of fresh, brackish and saline water in the subsoil has developed in geologic history and has been and still is affected by several natural processes but also by human intervention. Brackish and saline groundwater can be found in coastal areas, but also further inland. Features that affect coastal aquifers are summarized in Fig. 10.2. Obviously, from a hydro-geological point of view, the most interesting coastal areas are the hydro-geologic systems with sedimentary deposits ('a porous medium'), rather than hydro-geologic systems consisting of hard rocks.

Here it is important to define what is meant by saline water. Terms relating to the degree of salinity were suggested by the USGS.

Table 10.1 Classification of saline water

<i>Terms describing degree of salinity as used by USGS</i>	
<i>Description</i>	<i>TDS (mg/l)</i>
Fresh	<1000
Slightly saline	1000 - 3000
Moderately saline	3000 - 10000
Very saline	10000 - 35000
Brine	>35000

After Hem (1970)

### 10.3 CHEMICAL CHARACTERISTICS OF SALINE WATER

The density of groundwater is often only related to the concentration of dissolved solids in the groundwater, whereas the temperature is considered to be constant. In general, when the

quality of groundwater is in question, the salinity or total dissolved solids (TDS) is considered. An advantage of using TDS is that a rapid determination of TDS is possible by measuring the electrical conductivity of a groundwater sample.

The concentration of dissolved solids is subdivided into negative (anions) and positive ions (cations), see table 10.2. For instance, ocean water consists of 11 main components: Since in coastal groundwater chloride ( $\text{Cl}^-$ ) is the predominant negative ion, which is moreover investigated intensively, the interest is often focussed on the chloride distribution. When, in fact, only changes in the chloride distribution are simulated, the distribution of all dissolved solids is meant. In other words, the distribution of chloride ions is considered to represent the distribution of all dissolved solids. As such, a proportional distribution of all dissolved solids, which is present in ocean water, is also assumed to be present in groundwater under consideration.

The applied classification of fresh, brackish and saline groundwater based on chloride concentrations according to Stuyfzand (1993) is presented in Table 2.2. Obviously, there are various other classification systems possible, e.g. because the definition for fresh groundwater depends on the application of the groundwater. For instance, the drinking water standard in the European Community equals 150 mg  $\text{Cl}^-/\text{l}$  (Stuyfzand, 1986), while according to the World Health Organisation, a convenient chloride concentration limit is 200 mg  $\text{Cl}^-/\text{l}$  (Custodio et al., 1987). A chloride concentration equal to 300 mg  $\text{Cl}^-/\text{l}$  indicates the taste limit of human beings according to ICW (1976), while Todd (1980) gives 100 mg  $\text{Cl}^-/\text{l}$  as the limit when salt can be tasted. Livestock can endure higher concentrations: up to 1500 mg  $\text{Cl}^-/\text{l}$  may be accepted, in case the chloride concentration stays constant.

**Table 10.2 Composition of ocean water**

(The three components with low concentrations are Strontium ( $\pm 8$  mg/l), Barium ( $\pm 5$  mg/l) and Fluoride ( $\pm 1$  mg/l).

<i>IONS</i>		<i>mg/l</i>
Negative ions	$\text{Cl}^-$	19000
	$\text{SO}_4^{-2}$	2700
	$\text{HCO}_3^-$	140
	$\text{Br}^-$	65
Total negative ions		21905
Positive ions	$\text{Na}^+$	10600
	$\text{Mg}^{+2}$	1270
	$\text{Ca}^{+2}$	400
	$\text{K}^+$	380
Total positive ions		12650
Total Dissolved Solids		34555

Table 10.3 Classification into eight main types of fresh, brackish or saline groundwater

Main Type of Groundwater	Chloride Concentration (mg Cl/l)
<b>depending on the basis of chloride concentration, after Stuyfzand (1993). Oligohaline</b>	0 – 5
Oligohaline-fresh	5 – 30
Fresh	30 – 150
Fresh-brackish	150 – 300
Brackish	300 – 1000
Brackish-saline	1000 – 10000
Saline	10000 – 20000
Hyperhaline or brine	≥ 20,000

#### 10.4 CONCEPT OF FRESH-SALINE INTERFACE

A coastal aquifer contains the interface between the fresh water, which has relative density of approximately unity, and seawater that has a relative density in the order of 1.025. This difference in density results in the seawater lying underneath the freshwater on the landward side of coastline. The simplest way to view the situation is to assume that the fresh and saline water are immiscible. Thus the interface is sharp. In practice the fresh and saline water are miscible. Therefore, the interface is not sharp and a mixing zone exists, the thickness of which depends upon the hydrodynamics of the aquifer. If this transition zone is only a small fraction of the saturated thickness of the aquifer then the assumption of a sharp interface is reasonable and a good mathematical description of the shape of the saline wedge can be obtained. This idealized view of the situation is shown in Fig. 10.1. The thickness of the freshwater wedge decreases in the seaward direction and the slope of the water table steeping towards the coast. Therefore, the shape of the interface is concave upwards.

Although the differences in density appear to be small, they have a significant effect on piezometric heads and thus on the groundwater system. In many approaches, only fresh groundwater is considered in coastal aquifers, so no density differences are taken into account. In reality, however, density flow may highly affect groundwater flow in these coastal aquifers. In this chapter, a straightforward concept is applied which takes into account density flow in a simple way: the interface approximation based on the Badon Ghijben- Herzberg principle.

**Badon Ghijben-Herzberg principle:** The Badon Ghijben (1889) - Herzberg (1901) principle (BGH) describes the position of an interface between fresh and saline groundwater (Fig. 10.3). Following represents the Badon Ghijben-Herzberg principle:

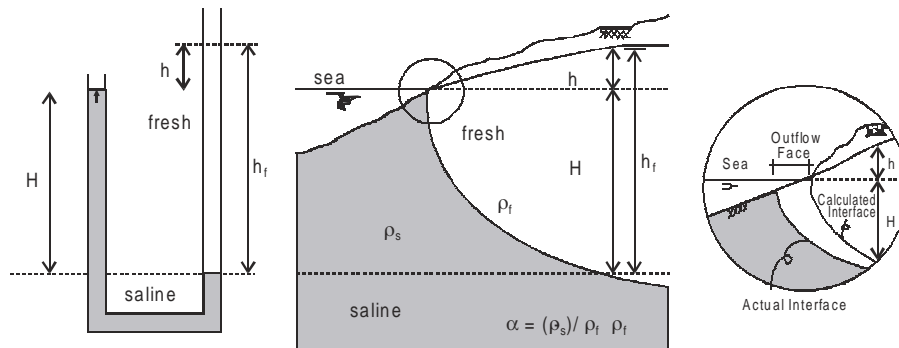

**Fig. 10.3** The Badon Ghijben-Herzberg principle: a fresh-salt interface in an unconfined coastal aquifer.

pressure saline groundwater = pressure fresh groundwater

$$\rho_s H g = \rho_f (H + h) g \Leftrightarrow \rho_s H + \rho_f h$$

$$h = \frac{\rho_s - \rho_f}{\rho_f} H \Leftrightarrow h = \alpha H$$

For  $\rho_s = 1025 \text{ kg/m}^3$  and  $\rho_f = 1000 \text{ kg/m}^3$ , the relative density difference  $\alpha = 40$ . The equation is correct if there is only horizontal flow in the fresh water zone and the saline water is stagnant. Though the position of the interface is not correct at the outflow zone, the use of the equation still gives a rather good approximation of the real situation. The Badon Ghijben-Herzberg principle was originally formulated for the situation that the transition zone between fresh and saline groundwater is only a small percentage of the thickness of the saturated freshwater body (thus, mostly in the order of several metres). Under these circumstances, a fresh-salt interface should be applied. This situation occurs in unspoiled sand-dune areas or (coral) islands, where the freshwater lens evolves by natural groundwater recharge. In addition, the principle can only be applied in case the vertical flow component in the freshwater body is negligible. In reality, however, such systems seldom occur. Most systems are not hydrostatic (the Dupuit-Forcheimer condition 2 should not be applied), and as a result, the formula leads to (small) errors, especially in the vicinity of the outflow zone. Nevertheless, though the position of the interface is not completely correct, the use of the equation still gives a rather good approximation of the real situation. As a matter of fact, the principle should only be applied under the following conditions:

1. The aquifer is homogeneous,
2. Hydrodynamic dispersion is negligible,
3. Vertical flow in the aquitard, horizontal flow is negligible,
4. Horizontal flow in the aquifer, vertical flow is negligible,
5. Saline groundwater is at rest:  $q_s = 0$ .

### 10.5 PHENOMENON OF ZONE OF DISPERSION

The general pattern of fresh groundwater flow in coastal aquifers is from inland recharge areas where groundwater levels (hydraulic heads) typically are highest to coastal discharge



areas where groundwater levels are lowest. Hydraulic head (often simply referred to as “head”) is a measure of the total energy available to move groundwater through an aquifer, and groundwater flows from locations of higher head (that is, higher energy) to locations of lower head (lower energy). The distribution of hydraulic head within an aquifer is determined by measuring ground-water-level elevations in observation wells that are open to a small interval of the aquifer. The groundwater level (elevation) at each well, most often is reported as meters above or below sea level. The upward direction of some of the groundwater flow paths near and beneath the ocean in the aquifer system indicates that groundwater heads in the deeper part of the flow system are above sea level near the coast.

Fresh groundwater comes in contact with saline groundwater at the seaward margins of coastal aquifers. The seaward limit of freshwater in a particular aquifer is controlled by the amount of freshwater flowing through the aquifer, the thickness and hydraulic properties of the aquifer and adjacent confining units, and the relative densities of saltwater and freshwater, among other variables. Because of its lower density, freshwater tends to remain above the saline (saltwater) zones of the aquifer, although in multilayered aquifer systems, seaward-flowing freshwater can discharge upward through confining units into overlying saltwater. In general, saltwater is defined as water having a total dissolved-solids concentration greater than 1,000 milligrams per liter (mg/L). Seawater has a total dissolved-solids concentration of about 35,000 mg/L, of which dissolved chloride is the largest component (about 19,000 mg/L).

The freshwater and saltwater zones within coastal aquifers are separated by a transition zone (sometimes referred to as the zone of dispersion) within which there is mixing between freshwater and saltwater (Figs. 10.4). The transition zone is characterized most commonly by measurements of either the total dissolved-solids concentration or of the chloride concentration of groundwater sampled at observation wells. Although there are no standard practices for defining the transition zone, concentrations of total dissolved solids ranging from about 1,000 to 35,000 mg/L and of chloride ranging from about 250 to 19,000 mg/L are common indicators of the zone. In general, the term “**transition zone**” implies a change in the quality of ground water from freshwater to saltwater, as measured by an increase in dissolved constituents such as total dissolved solids and chloride.

Within the transition zone, freshwater flowing to the ocean mixes with saltwater by the processes of dispersion and molecular diffusion. Mixing by dispersion is caused by spatial variations (heterogeneities) in the geologic structure and the hydraulic properties of an aquifer and by dynamic forces that operate over a range of time scales, including daily fluctuations in tide stages, seasonal and annual variations in groundwater recharge rates, and long-term changes in sea-level position. These dynamic forces cause the freshwater and saltwater zones to move seaward at sometimes and landward at sometimes. Because of the mixing of freshwater and saltwater within the transition zone, a circulation of saltwater is established in which some of the saltwater is entrained within the overlying freshwater and returned to the sea, which in turn causes additional saltwater to move landward toward the transition zone (Fig. 10.4). The horizontal (or lateral) width of the transition zone can be narrow or very wide. The vertical thickness of the transition zone also varies among aquifers, but generally is much smaller than the horizontal width and is limited by the total thickness of the aquifer.

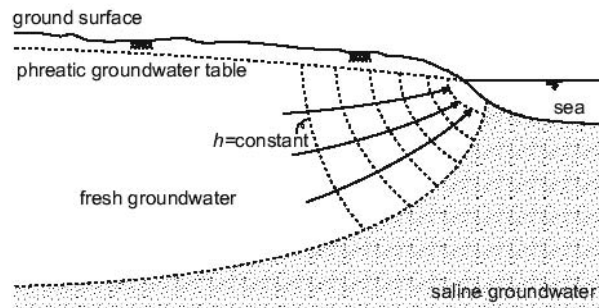

Fig. 10.4 (a)

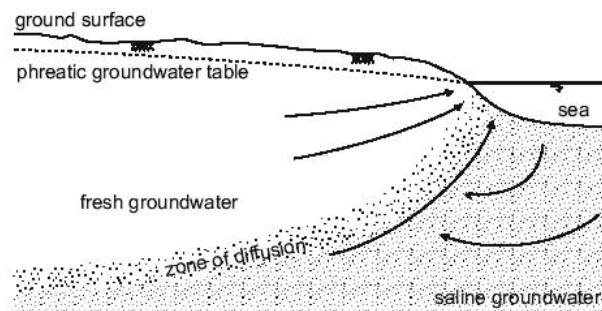

Fig. 10.4 (b)

**Figure 10.4 Salt Water Intrusion in a Coastal Aquifer: a)** balance between fresh water and static salt water and **b)** circulation of salt water from the sea to the zone of diffusion and back to the sea (modified from Henry, 1964).

For the convenience of illustrating freshwater-saltwater interactions as simply as possible and facilitating simplified scientific analysis of these interactions when possible, the freshwater and saltwater zones often are assumed to be separated by a sharp boundary that is referred to as the freshwater-saltwater interface, such as those shown in Fig. 10.4. Although the depth to this interface is quite variable, it can be estimated approximately under some circumstances by using a technique known as the Ghijben - Herzberg relation.

The variety of geologic settings, aquifer types, and hydrologic conditions along the Atlantic coast has resulted in many patterns of freshwater-saltwater flow and mixing in coastal aquifers. Following are some case studies that illustrate some of the important freshwater-saltwater environments that exist in aquifers along the Atlantic coast and highlight the many variables that control the natural occurrence and flow of freshwater and saltwater in coastal aquifers. The case studies progress from the glacial aquifer of Cape Cod, Massachusetts (Fig. 10.5), which is representative of shallow, single-layer aquifers, to two of the most productive regional aquifer systems in the United States—the Northern Atlantic Coastal Plain aquifer system that extends from Long Island, New York, through North Carolina, and the Floridian aquifer system that extends from South Carolina to Alabama. These are thick, multilayered aquifer systems that underlie thousands of square miles.

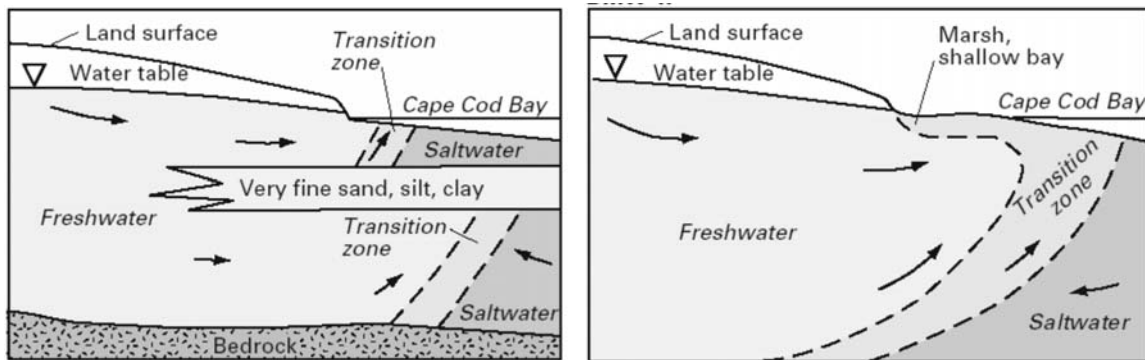

Fig. 10.5 Patterns of the freshwater-saltwater transition zone at three sites in the Cape Cod aquifer, Massachusetts.

In addition, the transition zone is also increasing as a result of the circulation of brackish water due to inflow of saline groundwater (mixing with fresh groundwater due to hydrodynamic dispersion), the tidal regime and human activities, such as (artificial) recharge and groundwater extraction at high and variable rates (Cooper *et al.*, 1964).

### 10.6 ANALYTICAL FORMULAE FOR THE FRESH – SALINE INTERFACE

In the following, analytical formulae for the interface between fresh and saline groundwater are presented for unconfined, confined and semi-confined aquifers, illustrated with some simple examples. For more information, see van Dam (1983, 1992). These analytical solutions increase the understanding of groundwater flow and fresh groundwater resources in coastal areas.

#### Unconfined aquifer (1D situation)

Freshwater lenses have evolved in unconfined (phreatic, water table) aquifers due to natural groundwater recharge (Fig 10.6). The three governing equations are (van Dam, 1992):

$$\begin{aligned} \text{(I) Darcy : } q &= -k (H + h) \frac{dh}{dx} \\ \text{(II) Continuity : } dq &= f dx \\ \text{(III) BGH: } h &= \alpha H \end{aligned}$$

Where

- $q$  = groundwater flow per unit coast length ( $L^2 T^{-1}$ ),
- $H$  = depth of the fresh-salt interface below mean sea level (L),
- $f$  = natural groundwater recharge ( $L T^{-1}$ ),
- $x$  = horizontal position (distance from the axis of symmetry) (L),
- $\alpha$  = relative density difference  $(\rho_s - \rho_f)/\rho_f$  (-),
- $h$  = piezometric head of fresh water with respect to mean sea level (L).

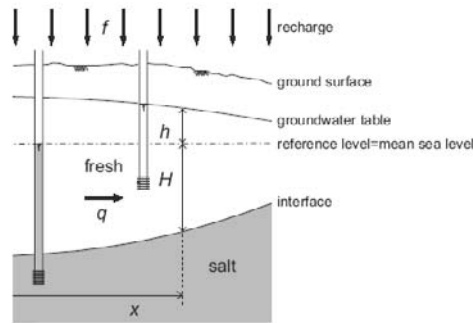

Fig. 10.6 The fresh-salt interface in an unconfined aquifer.

Combining the equations gives:

$$dq = f dx \Leftrightarrow q = fx + C_1$$

$$-k(H + h) \frac{dh}{dx} = fx + C_1 \Leftrightarrow -k(H + \alpha H)\alpha \frac{dH}{dx} = fx + C_1$$

$$HdH = \frac{fx + C_1}{k(1 + \alpha)\alpha} dx \Leftrightarrow \frac{1}{2}H^2 = \frac{-\frac{1}{2}fx^2 - C_1x + C_2}{k(1 + \alpha)\alpha}$$

The analytical formulae are as follows:

$$H = \sqrt{\frac{-fx^2 - 2C_1x + 2C_2}{k(1 + \alpha)\alpha}}$$

$$h = \alpha H$$

$$q = fx + C_1$$

**Example 10.1: Elongated Island**

A one-dimensional phreatic groundwater flow is considered through an elongated island or a strip of sand-dunes where a freshwater lens has evolved due to natural groundwater recharge (Fig. 10.7). The boundary conditions are:

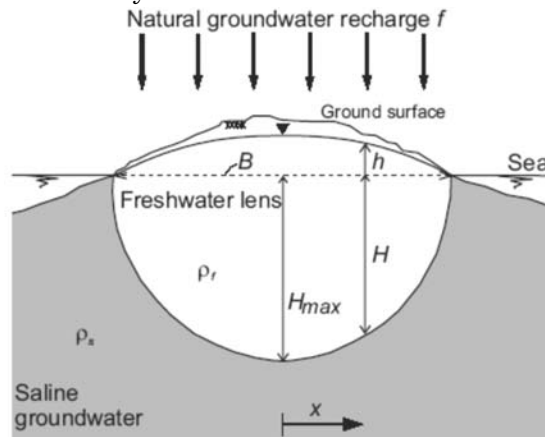

Fig. 10.7 The fresh-salt interface in an elongated island.

$$x = 0 ; q = 0 \rightarrow C_1 = 0$$

$$x = 0.5B ; H = 0 \rightarrow C_2 = f B^2/8$$

The depth of the fresh-salt interface becomes:

$$H = \sqrt{\frac{-f(0.25B^2 - x^2)}{k(1+\alpha)\alpha}}$$

where  $B$  = width of sand-dunes ( $L$ ). As can be seen, the depth of the fresh-salt interface  $H$  is proportional to the width  $B$  of the sand-dune area. The volume of water in the freshwater lens, which has the shape of an ellipse, is equal to:

$$V = \frac{1}{4} \pi (1 + \alpha) H_{\max} B n_e$$

Note that the  $\alpha$  in  $(1 + \alpha)$  accounts for the volume of water in the phreatic part of the lens. The characteristic time  $T$  is defined as:

$$T = \frac{\text{Volume of water in lens}}{\text{Inflow of water}} = \frac{\frac{1}{4} \pi (1 + \alpha) H_{\max} B n_e}{fB}$$

$$T = \frac{\pi n_e B}{8} \sqrt{\frac{1 + \alpha}{kf\alpha}}$$

For example, if  $B = 2000$  m,  $\alpha = 0.025$ ,  $k = 10$  m/day and  $f = 1$  mm/day, then the deepest position of the interface  $H_{\max}$  (in the middle of the lens) is 62.5 m and the highest phreatic groundwater level 1.56 m. With a porosity  $n_e$  equal to 0.35, the volume  $V = 52,396$  m<sup>3</sup>/m and  $T = 47.8$  years. This means that, without outflow of groundwater at the edges, it takes 47.8 years before the entire freshwater lens would be filled.

**Example 10.2: Salt Water Wedge**

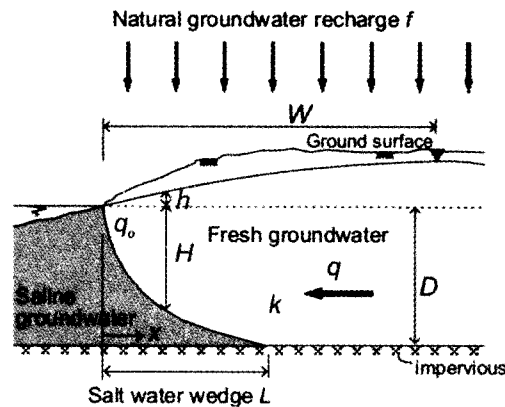

Fig. 10.8 Salt water wedge in a shallow unconfined aquifer.

In many shallow phreatic aquifers, the freshwater body originally touches the impervious base, thus creating a salt water wedge of length  $L$ , see **Fig. 10.8**. The corresponding boundary conditions are:

$$\begin{aligned} x = 0: q &= q_0 (q_0 = -fW) \rightarrow C_1 = q_0 \\ x = 0: H &= 0 \rightarrow C_2 = 0 \end{aligned}$$

where

- $W$  = width of the coastal aquifer up to the water divide ( $L$ ),
  - $q_0$  = natural groundwater outflow at the coastline  $x=0$  (negative sign) ( $L^2 T^{-1}$ ).
- Saline groundwater is stagnant. The length of the salt water wedge  $L$  is:

$$x = L : H = D$$

where  $D$  = thickness of the aquifer ( $L$ ). The equations of this case become:

$$H = \sqrt{\frac{-fx^2 - 2q_0x}{k(1+\alpha)\alpha}}$$

$$h = \alpha H$$

$$q = fx + q_0$$

$$q_0 = -fW$$

$$L = \frac{-q_0}{f} - \sqrt{\left(\frac{q_0}{f}\right)^2 - \frac{k}{f}D^2(1+\alpha)\alpha}$$

For example, if  $W = 3000$  m,  $f = 1$  mm/day,  $\alpha = 0.020$ ,  $k = 20$  m/day and  $D = 50$  m, then the length of the salt water wedge  $L$  is 175.1 m.

### Unconfined aquifer (axial-symmetric situation)

The three equations for the axial-symmetric situation, that is a circular sandy island with recharge, are (Van Dam, 1992):

$$(I) \text{ Darcy: } Q = -2\pi rk(H+h) \frac{dh}{dr}$$

$$(II) \text{ Continuity: } dQ = f2\pi r dr \Leftrightarrow Q = fr^2\pi + C_1$$

$$(III) \text{ BGH: } h = \alpha H \Leftrightarrow \frac{dh}{dr} = \alpha \frac{dH}{dr}$$

Combining these equations gives:

$$\begin{aligned} -2k(H+\alpha H)\alpha \frac{dH}{dr} &= fr + \frac{C_1}{\pi r} \\ HdH &= -\frac{fr + \frac{C_1}{\pi r}}{2k(1+\alpha)\alpha} dr \Leftrightarrow \frac{1}{2}H^2 = \frac{-\frac{1}{2}fr^2 - \frac{C_1}{\pi} \ln r + C_2}{2k(1+\alpha)\alpha} \end{aligned}$$

$$H = \sqrt{\frac{fr^2 \frac{2C_1}{\pi} \ln r + 2C_2}{2k(1+\alpha)\alpha}}$$

### Example 10.3: Sandy Island

The boundary conditions for a sandy circular island are:

$$r = 0; Q = 0 \rightarrow C_1 = 0$$

$$r = R; H = 0 \rightarrow C_2 = 0.5 f R^2$$

Above Eqn. gives, together with these boundary conditions, the formula for the axial-symmetric situation:

$$\text{where } H = \sqrt{\frac{(f(R)^2 - r^2)}{2k(1+\alpha)\alpha}}$$

- $R$  = radius of the sandy island (L),
- $r$  = distance from the centre of the circular island (L).

For example, if  $R = 3000$  m,  $\alpha = 0.02$  ( $\rho_s = 1020$  kg/m<sup>3</sup>),  $k = 25$  m/day and  $f = 0.5$  mm/day, then the deepest position of the interface  $H_{\max}$  (at  $r = 0$  m) is 66.4 m and the highest groundwater level 1.33 m. The content of water in this freshwater lens, is equal to:

$$I = \frac{2}{3} \pi (1 + \alpha) H_{\max} R^2 n_e$$

Note that the  $\alpha$  in  $(1 + \alpha)$  accounts for the volume of water in the phreatic part of the lens. The characteristic time  $T$  is defined as:

$$T = \frac{\text{Volume of water in lens}}{\text{Inflow of water}} = \frac{\frac{2}{3} \pi (1 - \alpha) H_{\max} R^2 n_e}{f \pi R^2}$$

$$T = \frac{\pi \sqrt{2n_e R^3}}{3} n_e \sqrt{\frac{f(1+\alpha)}{k\alpha}}$$

For example, if  $R = 5000$  m,  $\alpha = 0.02$ ,  $k = 50$  m/day and  $f = 500$  mm/year, then the deepest position of the interface  $H_{\max}$  (in the middle of the lens) is 129.5 m. With a porosity  $n_e$  equal to 0.35, the content  $I = 2.42 \times 10^9$  m<sup>3</sup> and  $T = 61.6$  years. This means that, without outflow of groundwater at the edges, it takes 61.6 years before the entire freshwater lens would be filled.

### Confined aquifer (1D situation)

A confined aquifer is enclosed by two aquicludes. The three equations involved are (see Fig. 10.9):

- (I) Darcy :  $q = -kH \frac{dh}{dx}$
- (II) Continuity:  $q = q_0$
- (III) BGH:  $h = \alpha (H + A)$

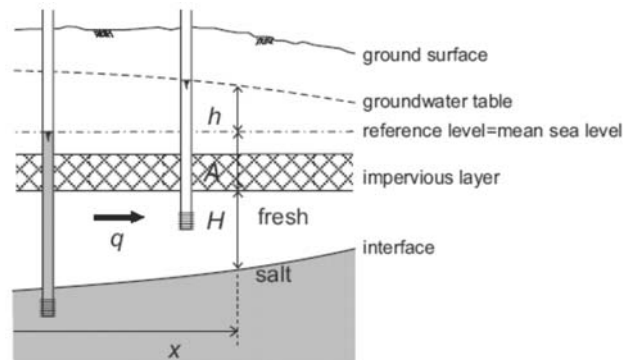

Fig. 10.9 The fresh-salt interface in a confined aquifer.

A confined aquifer is enclosed by two aquicludes. The three equations involved are (Fig. 10.9).

- (I) Darcy :  $q = -kH \frac{dh}{dx}$   
 (II) Continuity :  $q = q_0$   
 (III) BGH :  $h = \alpha (H + A)$

where

- $q_0$  = fresh groundwater flow from recharge in the uplands, per unit coast length ( $L^2T^{-1}$ ),
- $A$  = height of the sea level with respect to the top of the aquifer ( $L$ ).

Combining the equations:  $-kH \frac{dh}{dx} = q_0 \Leftrightarrow HdH = -\frac{q_0}{k\alpha} dx$

$$\frac{1}{2}H^2 = \frac{-q_0x}{k\alpha} + C \Leftrightarrow H = \sqrt{\frac{-2q_0x}{k\alpha} + 2C}$$

#### Example 10.4: Salt Water Wedge in a Confined Aquifer

The freshwater body touches the impervious base, thus creating a salt water wedge (Fig. 10.10). The corresponding boundary condition is:

$$x = 0 ; H = 0 \rightarrow C = 0$$

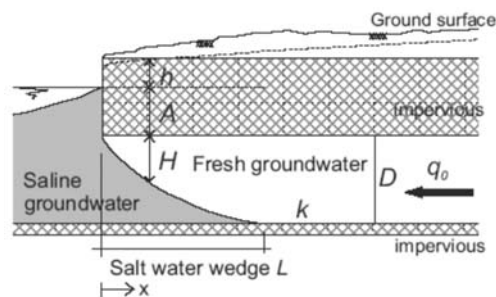

Fig. 10.10 The salt water wedge in a confined coastal aquifer.



The following formula can be applied to determine the length of the salt water wedge  $L$ :

$$x = L : H = D$$

Inserting these two equations gives:

$$H = \sqrt{\frac{2q_0 x}{k\alpha}}$$

$$h = \alpha (H + A)$$

$$q = q_0$$

$$L = -\frac{kD^2\alpha}{2q_0}$$

where,  $D$  = saturated thickness of the confined aquifer ( $L$ ).

As can be seen, the length of the salt water wedge is determined (inversely proportional) by the fresh groundwater flow  $q_0$ , since all other parameters remain constant. The fresh groundwater flow could differ due to changes in recharge in the uplands. Possible causes of reduced recharge are changes in the hydrologic regime (e.g. climate change) or human activities such as groundwater extraction. For example, if  $D = 40$  m,  $\alpha = 0.025$ ,  $k = 25$  m/day and  $q = -fW = -1$  mm/day  $\times 2000$  m =  $-2$  m<sup>2</sup>/day, then the length of the salt water wedge  $L$  is 250 m.

### **Intermezzo II: The Outflow of Fresh Groundwater**

In theory, the depth of the interface  $H$  below the impervious aquitard at  $x = 0$  equals zero (see Fig. 10.11). This means that the gradient of the freshwater head must be infinite large in order to obtain an outflow  $q_0$ . In reality, this situation does not occur. In fact, there exists a value for  $H > 0$  to assure outflow of freshwater towards the sea.

Glover (1959) obtained an analytical solution for the exact position of the interface, which causes a shift of the interface in  $x$ -direction (Fig. 10.11)

$$H = \sqrt{\frac{-2q_0}{k\alpha} + \left(x - \frac{q_0}{2k\alpha}\right)}$$

$$\text{for } x = 0; H_0 = \frac{q_0}{k\alpha}$$

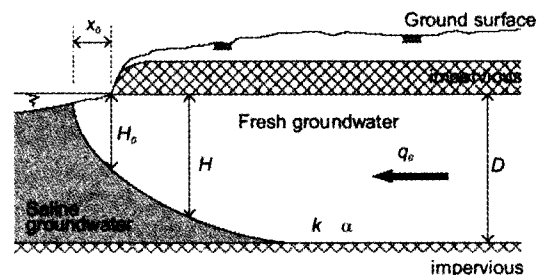

Fig. 10.11 The outflow of fresh groundwater in a confined aquifer.

The outflow length  $x_0$  is as follows:

$$\text{for } H = 0; x_0 = \frac{q_0}{2k\alpha}$$

### Confined aquifer (axial-symmetric situation)

The three equations for the axial-symmetric situation, that is a circular sandy island with a circular line of injection wells, are (Van Dam, 1992):

$$(I) \text{ Darcy : } Q = -2\pi r k H \frac{dh}{dr}$$

$$(II) \text{ Continuity : } Q = Q_0$$

$$(III) \text{ BGH : } h = \alpha (H + A) \Leftrightarrow \frac{dh}{dr} = \alpha \frac{dH}{dr}$$

Combining these equations one gets:

$$-2\pi r k H \alpha \frac{dH}{dr} = Q_0 \Leftrightarrow H dH = -\frac{Q_0}{2\pi k \alpha r} dr$$

$$\frac{1}{2} H^2 = \frac{Q_0 \ln r}{2k\alpha\pi} + C \Leftrightarrow H = \sqrt{\frac{-Q_0 \ln r}{k\alpha\pi} + 2C}$$

## 10.7 UPCONING OF SALINE GROUNDWATER

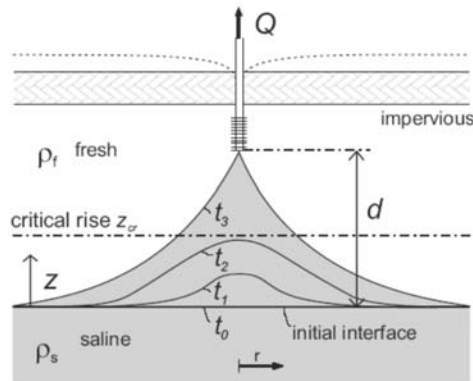

Fig. 10.12 Upconing of saline groundwater under a pumping well.

In areas where saline groundwater is present below fresh groundwater, the interface between fresh and saline groundwater may rise when piezometric heads are lowered due to well extraction. This phenomenon is called interface upconing (Fig. 10.12). Here the interface is horizontal at the start of pumping i.e. at  $t = t_0$ . Especially in overpumped areas, e.g. in a semi-arid zone, upconing of saline groundwater has become a serious threat to domestic water supply. Solutions are often difficult to invoke as water is scarce in these

areas and illegal extractions are not easily to be stopped. As a result of the extraction and the lowering of the piezometric heads in the fresh and saline groundwater zone, the interface will rise. In case of a continuous extraction of fresh water, the interface will rise until it reaches the pumping well. From that moment, the quality of the extracted groundwater deteriorates, and the pumping has to stop. When the pumping is stopped, the denser saline water tends to settle downward and to return to its former position. In order to avoid or to limit these negative effects, one should keep the extraction rate, and so the lowering of the piezometric head, below a certain limit. After reducing the extraction significantly, the interface may descend to its original position, though at a very slow pace. Another solution is to replace the extraction well to a location where saline groundwater is positioned at greater depth from the well.

### 10.8 EFFECT OF A RELATIVE SEA LEVEL RISE

Changes in global mean sea level (M.S.L.) will probably directly affect the coastal surface water system, rivers and estuaries, as well as the coastal aquifers.

Coastal aquifers within the zone of influence of mean sea level, obviously situated nearby the coastline itself, will be threatened seriously by sea level rise. Sea level rise will accelerate the salt water intrusion into these groundwater flow systems, which could result in a decrease of fresh water resources. In addition, the mixing zone between fresh and saline groundwater will be shifted further inland. Groundwater abstraction wells, which were previously located beyond the saline water zone, will there be in areas where upcoming of saline groundwater can easily occur. This can be considered as one of the most serious effects of sea level rise for every coastal aquifer where groundwater is heavily exploited.

#### ***Causes of Sea Level Rise***

**Thermal Expansion of Ocean Water:** Thermal expansion of ocean water is an important factor contributing to rise in sea level. It depends heavily on the temperature level of the ocean water and salinity.

#### ***Melting of Mountain Glaciers and Small Icecaps***

**Ablation of and Accumulation on Polar Ice Sheets:** The polar ice sheets will also react to climate change. Moreover the process of disintegration of ice sheets which are sensitive to small change in sea level or melting rates can accelerate the sea level rise process.

Here, the impacts of a relative sea level rise on the coastal surface water system, rivers and estuaries, and coastal aquifers are discussed:

- The coastal surface water system will directly sense the impacts of sea water level rise. Increases in storm surges, wave attack, flooding, and collapses of coastal protection defences could directly induce the inundation of populated areas and loss of lives must be feared. Furthermore, in the medium term, sea level rise would cause an increase in coastal erosion. If no compensating measures such as sand-suppletion are taken, it could result in severe shoreline retreat. Shoreline retreat will also affect coastal aquifers

(Fig. 10.13), e.g., by reducing the width of the sand-dunes along the coastline where fresh groundwater resources are situated and by diminishing the length over which natural groundwater recharge occurs. Both events may lead to a decrease in fresh groundwater resources.

- Rivers and estuaries will experience an increased salt water intrusion in case of sea level rise, if the river bed elevation can not match with sea level rise. Because the sediment load at many river mouths is reduced significantly these last decades among others due to human activities (building dams, sand-mining), quite some rivers and estuaries are expected to have an increased salt water intrusion. This could threaten adjacent aquifers along rivers and estuaries from which groundwater is extracted. Furthermore, the backwater effect of sea level rise would also decrease the safety against flooding over large distances upstream the river mouth. Especially areas adjacent to rivers with valley slopes only slightly steeper than river slopes have to be protected by embankments.
- Coastal aquifers within the zone of influence of M.S.L. can be threatened by sea level rise (Fig. 10.13). Intrusion of salt water is accelerated into these aquifers, which could result in smaller freshwater resources (Oude Essink, 1999b, 2000a). Furthermore, seepage will increase quantitatively in those areas and this seepage could contain more saline groundwater. In consequence, crops may suffer from salt damage and fertile agriculture land might change into barren land. In addition, the mixing zone between fresh and saline groundwater will be shifted further inland. Extraction wells, which were previously located beyond the salinization zone, will then be situated in areas where upconing of brackish or saline groundwater can easily occur. This can be considered as one of the most serious effects of sea level rise for every coastal aquifer where groundwater is heavily exploited.

It is important to recognize that impacts of sea level rise must be considered in relation to impacts of human activities. It is very likely that not sea level rise, but human activities will cause a severe salinization of most coastal aquifers in the future. A reason for this assumption can, among others, be deduced from the time lag between causes and effects. Sea level rise takes place progressively. The time characteristic of sea level rise is in the order of decades. On the other hand, the time characteristic of human activities, such as groundwater extraction projects, is in the order of years. Before negative impacts, such as upconing, are recognized, it may be too late to take countermeasures.

### ***Saltwater Intrusion into Estuaries***

During extended droughts, decreased river flow allows the saline water to migrate up the estuary. A rise in sea level will also cause saltwater to migrate upstream. The general methods of preventing saltwater intrusion up estuaries are similar for sea level rise, drought conditions, and storm surge. Storm surge elevates the ocean in relation to the estuary water level, causing saltwater intrusion. A major difference is that storm surge and drought conditions last for a limited duration, whereas the sea level rise is expected to last much longer.

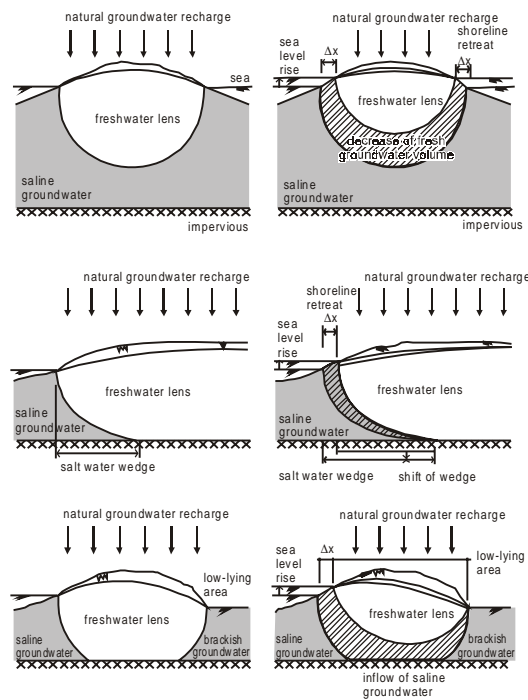

Fig. 10.13 Effects of a sea level rise on coastal aquifers.

In order to minimize saltwater migration, river basin commissions provide low-flow augmentation and water conservation requirements during periods of low flow. Water from rainfall and snowmelt are stored in large surface reservoirs and released continuously during droughts to maintain a flow that helps repel the saltwater from migrating upstream. These planning agencies recognize the need to sustain stream flows to protect freshwater intakes, instream uses (including fish migration and fish production), and shellfish beds, as well as treated-waste assimilation, recreation, and salinity repulsion. An economic justification is usually necessary, showing that the cost of the mitigation is less than the anticipated benefits.

### 10.9 CONTROL OF SALT WATER INTRUSION

It takes a considerable time before the salinization of the subsoil of groundwater systems due to the negative effects of human activities (e.g. dramatic lowering of the piezometric heads due to excessive overpumping) is actually observed. The main reason is that in the salinization process enormous volumes of fresh groundwater have to be replaced by saline groundwater.

Besides technical countermeasures as described below, other instruments are available to cope with salt-water intrusion problems. For instance, an intensive cooperation between (local) authorities and water users is essential to control the extraction per capita. Educating, training, informing the water users, and participation of water users in regular decisions could be very effective in coming to a lower water use. In addition, groundwater extractions could be restricted through a system of permits. It may be necessary to reduce agricultural

activities and move to other places. A shift to more salt resistant crops could enlighten the need to extract groundwater of high quality. Finally, in some areas (e.g. tropical islands), desalination of saline water could relieve the stress on groundwater resources though at the expense of high-energy costs.

### 10.10 COUNTERMEASURES TO CONTROL SALT WATER INTRUSION

As countermeasures to control the salt-water intrusion probably also need a long time to become effective, they should be taken in due time. In general, the salinization may be substantial in coastal groundwater flow systems where the existing piezometric heads are lower than a few meters above *M.S.L.* In those cases, countermeasures should be applied to reduce salt-water intrusion. The following countermeasures against the salinization process can be considered (Fig. 10.14).

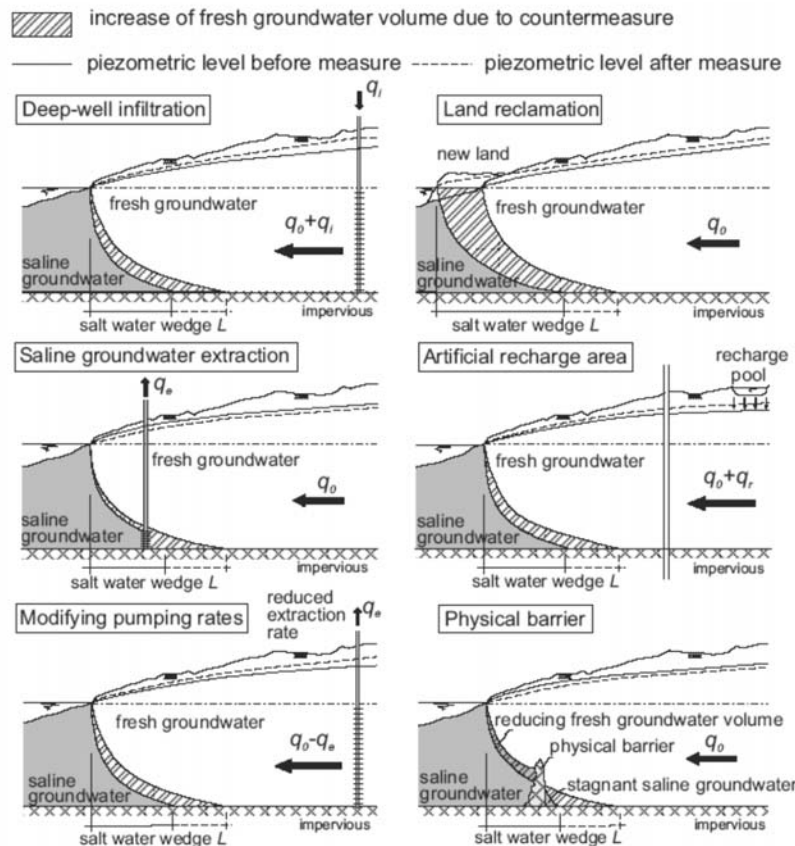

Fig. 10.14 Countermeasures to control salt water intrusion.

Recent increases in global population, together with enhanced standards of living, have created greater demand on water resources, requiring improved groundwater management. Any new groundwater development should take into account the possibilities of saline intrusion, and ensure adequate control, with prevention of saline intrusion being seen as the ideal. Any intrusion carries with it the risk that the matrix of the aquifer will become contaminated, causing a permanent loss of freshwater storage capacity. The impact of saline intrusion on the Nile delta is described in a case study.

Where the possibility of intrusion exists, appropriate monitoring procedures should be routinely carried out. A network of sampling piezometers should be established to monitor heads and salinity changes along the coastal fringe.

Actual methods for controlling saline intrusion vary widely according to geology, extent of the problem, water use, and economics. They generally rely on the principle that, in order to limit seawater intrusion, some freshwater outflow above the saline wedge must be maintained. They can be broadly divided into methods relying on barriers and those dependent on aquifer management; some of these are discussed briefly below.

**Barriers:** Barriers to saline intrusion include recharge mounds, abstraction troughs, and physical barriers.

**Abstraction Troughs:** An abstraction barrier is created by maintaining abstraction along a line of wells close to the coast. This creates a pumping trough, with seawater flowing inland to the trough, and freshwater flowing seaward. The fresh water can then be utilized by inland wells.

**Recharge Mounds (Injection Barrier):** This approach uses recharge wells to maintain a pressure ridge along the coast. The injected water flows both landward and seaward. Ideally high quality fresh water is required for recharge, necessitating the development of a supplemental source.

**Physical Barriers:** An impermeable subsurface barrier may be created through the vertical extent of the aquifer, parallel to the coast. The barrier may be constructed of various materials including sheet piling, puddled clay, cement grout, or bentonite. The approach is best applied to small-scale problems.

**Aquifer Management:** Aquifer management i.e. modification of pumping, is generally carried out on a regional scale. Modification requires changes in operational practices.

**Control of Pumping:** Modifying pumping practice and/or well system through reduction of withdrawal rates and/or adequate relocation of extraction wells. The desired extraction rate should preferably be extracted by well-distributed shallow wells to prevent excessive upconing. In most situations, groundwater withdrawal for domestic, agricultural and industrial water supply has not been reduced during periods of droughts, so that salt water intrusion tends to occur anyway. In the case where an aquifer is underlain by saline fluid, upconing can be limited by proper design and operation of wells (Bowen (1986)). For example, wells should be as shallow as is feasible, and should be pumped at a low, uniform rate. Riddel (1933) suggested that a multiple well system with small individual pumping rates was preferable to a high capacity single well. Another alternative is an infiltration gallery (i.e. horizontal well) which has been reported to help reduce the upconing that can result from heavy pumping by a vertical well (Das Gupta (1983)). However, these are expensive to install, and similar benefits may be obtained by utilizing several shallow wells.

**Redistribution of Pumping:** Relocating pumping wells inland may help to re-establish fresh water outflow. Some schemes to reduce the effects of saline intrusion in the Chalk of Great Britain have utilised two sets of boreholes, one inland and one coastal (Headworth and Fox (1986)). The coastal wells are pumped during periods of high groundwater levels when outflow is large, with the inland wells being used during periods of low water levels.

The present countermeasures to prevent and/or retard salt water intrusion due to the negative effects of human activities resemble the possible solutions to counteract the effects of a relative sea level rise on the salinization process. In fact, sea level rise is basically the same as equally lowering the land surface and thus the phreatic groundwater level. Nowadays, dramatic lowering of the piezometric heads due to excessive overpumping already occurs in many groundwater systems around the world, see table 1.2. It is obvious that, for those systems, the impact of a (relatively small) sea level rise (e.g. 0.5 m per century) on the groundwater system will be of marginal importance compared to the effect of an increase in withdrawal rate. The economic feasibility of countermeasures should be investigated. For instance, it is recommended to derive the optimum position of well lines and rates of extraction or infiltration. Moreover, the countermeasures should be adapted and optimized in the course of the realization of the measure, based on changes in the salinity of the subsoil.

Listed below are a number of **Alternative seawater barriers** which have been proposed.

**Slurry Walls:** The construction of a slurry wall involves the cutting of a bentonite slurry stabilized trench. This is accomplished using a large backhole excavator supplemented by a clam shell (a large tool operated by a crane for the purposes of digging). The ditch is then backfilled with a mixture of soil-bentonite, a mixture of cement-bentonite, or plastic concrete materials that, when stabilized, forms an impervious barrier to seepage. Because of the need to cut a trench using heavy equipment, this procedure has limitations with respect to disturbances of existing utilities which are often located near the ground surface.

**Grout Curtains:** Grout curtains are constructed by drilling 2- to 6-inches diameter holes along a single line or multiple parallel lines. Grout is then injected into the holes under pressure to fill the surrounding soil pores or rock fractures. By placing these holes on a tight enough spacing (typically 3 to 10 feet spacing), a grout barrier of variable thickness is created. Grout curtains can be installed to most any depth and can be surgically injected to treat specific depth zones.

**Air Injection:** Air injection is used in the development of oil and gas fields and during tunneling to cutoff the flow of water. Compressed air injected into the groundwater attempts to cause a piezometric rise in water level that can be used to alter groundwater gradients and flow directions. Air entrained in soil pores causes an overall decrease in the permeability of the aquifer which could be used to reduce flow across specific zones.

**Bio Wall:** This technology involves the injection of starved bacteria cultures into the pores of the aquifer media to develop a biological subsurface plug or bio-wall. This method uses microbial growth to fill in the void space found in all soils, thus decreasing its permeability. The wall is maintained by periodic injection of nutrients to feed the bacteria in specific zones. This type of wall has only been evaluated by modeling and in the laboratory.



### 10.11 MONITORING OF SALT WATER INTRUSION

Monitoring of the quality of groundwater on a regular basis is important in areas where salt-water intrusion may be expected. The conventional way is to use the results of groundwater sample analyses. Besides this, geophysical exploration techniques have proven to be very useful. Geoelectrical sounding is used for regional exploration of subsurface layering. The result obtained is a subdivision of the subsoil into layers with different specific electrical resistivity values. The specific resistivity values of layers are strongly affected by the salinity of the pore water, making geo-electrical sounding very useful with regard to salinization.

Well systems in coastal areas, used for the extraction of drinking water, have to be safeguarded and need extra attention. The conventional way is to set up a network of observation wells around the well system and to analyze groundwater samples and piezometric heads. These wells should be located at different levels and at such a distance that in case of salinisation the eventual progression of the saline front can be observed and appropriate and timely countermeasures can be taken. If saline water is already present in deeper layers also observation wells will have to be situated under the extraction wells and deep enough to detect up coning already at an early stage. Gradients in piezometric head indicating flow from saline parts of the hydrogeological system towards the extraction wells should be avoided (Fig. 10.15). In this case, flow lines through the transition zone will always carry brackish water to the extraction system and may lead to abandoning of wells.

At present very often a special application of an electrical resistivity method is used in combination with observation wells. The system includes a multistrand cable, an electrical resistivity meter and a switch. The cable is installed vertically in the subsoil, mostly taped to the tube of an observation well. On the outside of the cable and at regular intervals pairs of electrodes are applied. The system applies a 4-electrode measuring system: 2 current electrodes (C) and 2 potential electrodes (P), with one pair (C, P) at the surface and the other pair (C, P) in the subsoil. Switching from one pair of electrodes to the next results in resistivity values related to depth. Low specific resistivity values indicate salinization. This so-called Permanent Electrode System (PES) offers the possibility to repeat measurements as often as desirable and is very well suited for automation.

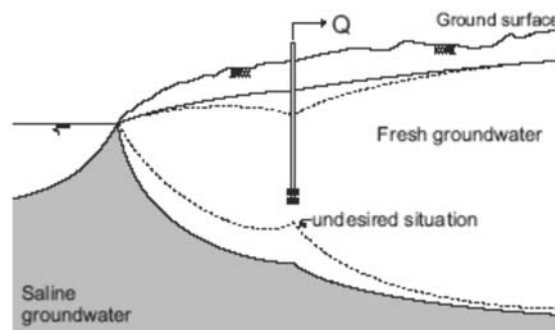

Fig. 10.15 Piezometric heads in a coastal aquifer due to pumping.

### 10.12 AN OVERVIEW OF SALT WATER INTRUSION ALONG GUJARAT COAST, INDIA

Gujarat has approximately one-third part of the total coastal length of India. In Gujarat, which has 1600 km long coastal reach, Saurashtra has 925-km long coastal reach, starting from Bhavnagar to Okha and from Okha to Malia.

Geographically Saurashtra has an extent of about 60,000 km<sup>2</sup> lying on the Arabian Sea coast. The extensive sheet of lava covers more than half of the area of the region. The central portion of Saurashtra is like turtle's back. There are total 71 rivers flowing in all the directions from the central portion of the plate and meeting the sea. All these river basins are more or less homogeneous in their hydrometeorological characteristics. All these rivers are short in length and getting flood instantaneously and recedes quickly having rising limb flood hydrograph not more than 3 to 4 hours. Thus during rains, they get flooded instantaneously and flood recedes quickly. Except Shetrunji and Bhadar rivers, all the rivers run dry after monsoon. The permeable geological formations along Saurashtra coast have produced rich aquifers of sweet water in low rainfall region but the overexploitation of groundwater has resulted into pollution of the aquifers by the seawater ingress.

Sea water intrusion is found in public and individual water wells at many coastal areas of Saurashtra region of Gujarat state. Fluctuations occur depending on seasonal rainfall (aquifer recharge) and tidal movement. Over-pumping of these sensitive aquifers, which are under the influence of seawater intrusion, will further degrade the aquifers and pull in more seawater, thus increasing their salt content. Chloride, sodium, carbonate, bicarbonate, pH and conductivity levels are all elevated as more seawater is pulled into the freshwater. The tidewater through creeks mixed up with groundwater and has further deteriorated the quality of the groundwater. In case of lack of sufficient rainfall and irrigation facility farmers were compelled to use this poor quality of water to protect their crops which has resulted into the damaging of the soil structure of their farms. This has reduced the productivity as well as the cost of the land.

In absence of farming some people have diverted towards mining of limestone, which is an important ingredient in manufacturing of cement. In addition, these stones are also used to construct houses and are locally called "Bela stones". Due to the mining of limestone the sea water intrusion in the fresh water aquifer has been increased as was acting as a protecting layer to prevent the intrusion. Another problem causing concern in this area is the layer of Miliolitic limestone, which is very cavernous and permeable in nature through which seawater intrudes at very fast rate. In addition, with the establishment of gigantic industries in the coastal belt, the demand of groundwater has been increased.

The Government first notices the deterioration in water quality in early 60s, but the problem was limited in both area and intensity. But by 1970, the problem was intensified and became widespread, causing alarm at all levels and demanding immediate action between the 160 km long coast between Madhavpur to Una. The area affected by seawater intrusion has increased from 35,000 ha in 1971 to 1,00,000 ha in 1977. The area irrigated by groundwater supply has been reduced from approximately 24,500 ha to 16,900 ha as many wells had to be abandoned in the same period. Approximately 2,80,000 people of living in the 120 villages of the area were affected which has further resulted into the migration of people from their motherland.

In 1976, to study the effects of salinity ingress in coastal region, Government of Gujarat had appointed a High Level Committee – I (H.L.C. - I). The area selected for preventive measures was between rivers Madhuvanti near Madhavpur and Rawal near Una. Based on the studies of H.L.C. – I area Government of Gujarat had appointed High Level Committee – II (H.L.C. - II) in 1978 to study and prevent the salinity ingress problems in rest of the coastal area of Saurashtra and Kutch. H.L.C. – II committee has divided the coastal reach into three parts:

- 1) Bhavnagar to Una reach.
- 2) Madhavpur to Malia reach.
- 3) Malia to lakhapat reach for Kutch region.

### **Consequences of Salinity Ingress**

In Bhavnagar to Una reach, total 166 villages of seven coastal talukas of Bhavanagar; Amreli and Junagadh districts are affected by salinity ingress covering an area of about 1,39,212 hectares. 4600 open wells without pump sets and 4200 wells with pump sets have gone out of order. Total population of 2,20,000 souls was affected by salinity ingress. The break up of affected area by various stages of salinity is as under.

Area affected by inherent salinity	<b>87,867 ha</b>
Area affected by seawater ingress	<b>33,055 ha</b>
Marshy land including tidal ingress	<b>18,290 ha</b>
<b>Total</b>	<b>1,39,212 ha</b>

In Una to Madhavpur reach, total 120 villages of five talukas are affected by salinity ingress covering an area of about 1,00,000 ha. 12,562 wells have gone saline affecting the population of about 2,80,160 souls and irrigation land of 19,850 ha.

Area affected by seawater intrusion	<b>86,243 ha</b>
Marshy land	<b>13,757 ha</b>
<b>Total</b>	<b>1,00,000 ha</b>

In Madhavpur to Maliya reach, 248 villages are affected by salinity ingress in 13 talukas of Junagadh, Porbandar, Jamnagar and Rajkot districts covering an area of about 4,60,120 ha. The break up of affected area by various stages of salinity is as under.

Alluvial Ghed area coral beds, saline alluvial of Maliya	<b>1,70,200 ha</b>
Marshy land	<b>99 500 ha</b>
Area having inherent salinity	<b>1,32,230 ha</b>
Area having seawater ingress	<b>17,600 ha</b>
Area affected by seawater inundation	<b>40,590 ha</b>
<b>Total</b>	<b>4,60,120 ha</b>

Moreover 6,000 open wells and 5,388 wells with pump sets are affected by salinity in above area.

Effect of salinity has become so severe that people and cattle actually start migrating from coastal villages towards the nearby urban areas and are depending less and less on land for their lively-hood.

The rate of growth in population is observed as 27 per 1000 souls as the state as a whole, whereas in salinity-affected area of coastal strip this rate is 7 to 20.

Adverse effect of salinity is also reflected in agriculture activity along the coastal area. For example, Mahuva taluka of Bhavnagar District, once known for its rich output of Coconut, Banana, Guava and 'Jamadar' Mango plantations, has turned into shambles due to salinity. The yield per hectare has gone down considerably affecting local market. The farmers residing near the saline reaches are in despair. Their land value had also gone down more over fruits have also lost their quality.

In these circumstances, an immediate implementation of integral programme of preventing salinity ingress had become necessary in the interest of common people of the affected area.

### ***Solution of the Problem***

The H.L.C. formed by the Government of Gujarat have studied the area and suggested some solutions as under.

- 1) Management techniques
  - a. Change in cropping pattern
  - b. Regulation of groundwater extraction
- 2) Recharge technique which suggests construction of
  - a. Recharge reservoir.
  - b. Recharge wells.
  - c. Recharge tanks.
  - d. Check dams.
  - e. Spreading channels.
  - f. Nala plugs.
  - g. Afforestation.
- 3) Salinity control techniques suggests construction of
  - a. Tidal regulators and Bandharas.
  - b. Fresh water barriers.
  - c. Extraction barriers.
  - d. Static barriers.
- 4) Coastal land reclamation.

### ***Management Techniques***

The techniques suggested under this measure will require imposing some controlling on public including farmers through legislation and extension services. Excessive use of groundwater by constructing number of open wells and tube wells has to be checked so that the total

withdrawal is not more than the annual recharge. The farmer can also be trained to go in for crops, which can resist salinity.

### **Cropping Pattern**

The cropping pattern of an area depends upon mainly on soil types, prevailing climate and the irrigation facilities available.

The area between Bhavnagar to Una mainly grows the crops of Groundnut, Jowar and Bajra in Kharif and Wheat in Rabi. The area between Madhavpur to Porbandar grows the crops of Jowar, Gram, Wheat, Groundnut and Bajra etc. In low-lying area of Ghed Cotton is sown in Kharif depending upon the availability of rainfall. In Jamnagar district Bajara, Groundnut and Cotton are sown in Kharif and Wheat, Mustard, Potato, Garlic, Chilly; Lucerne etc. are sown in Rabi depending upon rainfall available. In Morbi and Maliya talukas of Rajkot district Cotton, Bajra, Jowar and Groundnut are sown in Kharif and Wheat in Rabi. Horticulture crops like Coconut, Guava, Pomegranate and Mangoes are planted in Bhavnagar to Una reach. While in Madhavpur to Maliya reach, there are no horticulture plantations found.

In order to make use of the saline water for irrigation, following table suggests guidelines depending upon the degree of salinity and soil types. Crops like Date palm, Bor, Bamboo, Eucalyptus, Guava, and Coconut are moderately to highly salt tolerant crops. Crops like Wheat, Bajra, Jowar, Mustard, Cotton, Castor can withstand the salinity up to some limit.

### **10.13 RECHARGE TECHNIQUES**

Some forms of Artificial Recharge Techniques have to be adopted in areas where groundwater withdrawal is higher than the natural recharge.

**Artificial Recharge** can be undertaken by creating storage of freshwater and maintaining the head for as long a period as possible to accelerate the induced infiltration. The induced recharge can be done by construction of check dams, recharge tanks, spreading channels, reservoirs and recharge wells.

**Check Dams** are used for creating small storages on existing rivers for recharge. The effects will depend on type of formations under the water-spread areas. These check dams will be charged often by releasing water from U/S feeder tanks wherever possible.

**Recharge Tanks** are constructed by making use of local depressions near the riverbanks. These recharge tanks are filled by diverting surplus water of river through linking channels.

**Recharge Wells** are constructed for deeper as well as lateral recharge by puncturing several different geological formations, through riverbed.

**Afforestation** has positive role in increasing retention and improving soil permeability and thereby the rate of recharge. This technique being slow is used as supporting one in conjunction with above recharge techniques.

**Gully Plugging** is also done on all the small tributaries of the rivers to supplement filter of vegetation cover. The gully plugging can arrest floodwaters and detain the same for longer duration on ground for recharge and also check soil erosion.

#### 10.14 SALINITY CONTROL STRUCTURES

**Tidal Regulator:** Tidal Regulator is a gated structure constructed near the mouth of the river to prevent upland movement of tidal water in the upstream and to create sweet water storage in the upstream, which is used for lift irrigation. The reservoir water so stored will also recharge the aquifers of the surrounding area. Moreover it also stops the tidal inundation.

The main function of the Tidal Regulator is to prevent the tidal ingress into the lands by sealing the mouth of the river. Hence, generally the gates remain in closed condition round the year to prevent the entry of tidewater into the lands.

There are 71 major and minor rivers within the reach between Bhavnagar and Maliya Miyana. Tides are entering through estuaries of the rivers twice a day. Due to flat slopes of the riverbeds near the mouth, tides are running into the land for about 2 to 6 km distance. It is generally observed that village wells surrounding this tidal estuary have been converted saline due to the constant process of tidal ingress into the land. As a result of over-withdrawal of sweet water from these wells, process of contamination is increasing year by year and more and more numbers of wells are turning saline which are affecting agricultural land and production there from. Besides direct infiltration of seawater also take place through riverbeds and contaminate groundwater. It is therefore, necessary to stop tidal ingress into the land by sealing the mouths of these rivers by construction of some structures near the mouths.

It is proposed to categorize such structures into two types. Structures on large rivers would be constructed with gates, while structures on small rivers would be constructed without gates as solid barriers. The height of these structures will be so kept as to keep submergence of land to the minimum and yet the projects remain economically viable.

The structures with gates on the large rivers, which will be named as **Tidal Regulator**, will be constructed with impervious cut off below the foundation. Such cut off will be taken down to relatively impervious strata that will enable to prevent tidal ingress even through foundations strata directly to contaminate groundwater. Thus, the tidal regulator will be designed and constructed in such a way that it would not only arrest the tides entering the estuary from surface but it would also be possible to prevent seepage of sea water into the land and polluting sweet groundwater.

The top of the gate will be kept above maximum tide level during the year. It is well known that tidal range across Saurashtra coast is nearly the highest in the country. But for design of Tidal Regulator one has to deal with maximum tide level or highest of high tide level. Normal practice of keeping the top of the gate about 1 meter above highest of high tide level so that the waves from the sea do not splash above the gates and pollute the sweet water reservoir behind the gate.

Extra exercise is also necessary to study the submergence on the up stream of this structure when the maximum design flood passes over the structure. If a good valley is available on the up stream of the structures and it is convenient to store water at a higher level without increasing submergence substantially and affecting surrounding villages. It can be attempted to raise the crest of the Tidal Regulators to store more sweet water for irrigation use.

During floods, gates are opened and regulated as per flood forecast so as to allow the flow of the excessive flood water without creating undesirable submergence of the land in the up stream. As soon as the flood starts receding, the gates are closed to store fresh water on upstream side. The stored sweet water will improve the existing water supply of the affected villages situated near Tidal Regulator. Thus villages situated in the periphery of the proposed Tidal Regulators will be benefited by improved quality of water due to such structures.

The sweet water reservoir that will be created behind Tidal Regulator is proposed to be used for irrigation in the surrounding command areas through lift. It will be possible to do irrigation, three to four times during monsoon and protect Kharif crop. As the gates are provided on the Tidal Regulators, it will be possible to fill the reservoir during every flood in the monsoon by proper regulation of gates. Incidentally, it will also be possible to increase recharge into the groundwater through the command area also. Thus, the recharge of sweet water through command area will be over and above that which will take place through the bed of the reservoirs.

The reservoir waters will improve the surrounding village wells, thereby water supply problems of the surrounding villages will also be solved to a great extent. The lands around the reservoirs will be leached out through use of sweet water for irrigation and will make it possible to fetch higher yields from the same fields.

**Bandhara:** Bandhara is an ungated structure constructed near the mouth of the river to prevent upland movement of tidal water in the upstream. It stores the sweet water in upland which helps to recharge the aquifer for pushing the salt water seawards and for lift irrigation. Thus it reduces the pressure on groundwater utilisation and over withdrawal of groundwater. Bandhara works on the same function to prevent the tidal ingress into the land by sealing the mouth of the river.

As per normal practice, the top of the Bhandharas shall be kept 1 meter above the highest tide level so that the waves from the sea side will not splash above the Bhandharas and pollute sweet water reservoirs behind them. In case where submergence does not become a problem, the Bhandharas shall be raised even higher to store more sweet water.

It is also possible to do irrigation three to four times during monsoon from the reservoir. This will facilitate to protect Kharif irrigation and at the same time increase recharge from larger areas by spreading reservoir waters in the command areas through lift. The surrounding villages will get benefit by the probable improvement in the well waters.

Bhandharas will be constructed with impervious cut off below the foundation. Such cut off will be taken down to relatively impervious strata and will enable to prevent tidal ingress through foundation strata directly to contaminate groundwater.

**Spreading Channel (Static Barrier):** Spreading channels (Static Barriers) are preferred when existing river channels are to be used as connecting channels from upstream reservoirs to spreading channels or when recharge is desired in narrow strip near seashore for creating fresh water barrier to stop seawater intrusion (Fig. 10.16).

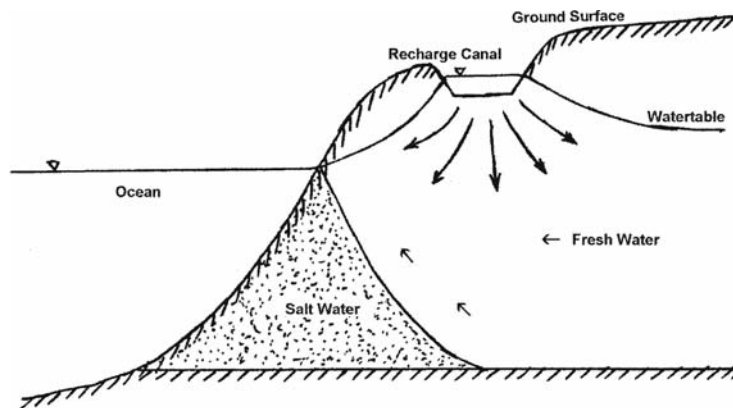

Fig. 10.16 Construction of spreading channel to prevent seawater intrusion in coastal aquifer.

**Linking Canal:** A canal joining two or more rivers or stream in coastal region is called Linking canal. Sometimes in the coastal region rainfall occurs over a small region due to cyclonic storms. Because of this rainfall there might be a runoff in one river and other nearby river may run dry. If a canal joining these two rivers is constructed then runoff water from one river can be diverted to another river and recharge over larger area can be obtained. If in case both the rivers get flood then also linking canal gets flooded and more area comes under freshwater recharge. These types of canals are suitable for areas where a porous stratum, limestone layer is situated near the upper layer (Fig. 10.17).

**Radial Canal:** Radial canals are constructed towards the landward side from the reservoir created by the construction of tidal regulator or bandhara in the coastal region. Slope of the land is towards bandhara or tidal regulator while these canals constructed towards landward side from the reservoir. Thus depth of these canals increases as it goes away from reservoir. Floodwater will flow in these canals and farmers of surrounding regions can take advantage of this water and irrigate their fields, thus much more area can be benefited (Fig. 10.14).

### 10.15 COASTAL LAND RECLAMATION

Along most of the coastal length of Gujarat, high tides are covering more than 0.3 million hectares of land and are converting this land saline. It is possible to reclaim these saline lands by constructing bunds along the seacoast to stop tidal ingress and by leaching the salts with the application of sweet water. Initially sweet water will be made available from proposed reservoirs in this reach. The lands so re-claimed would then be available for the cultivation.



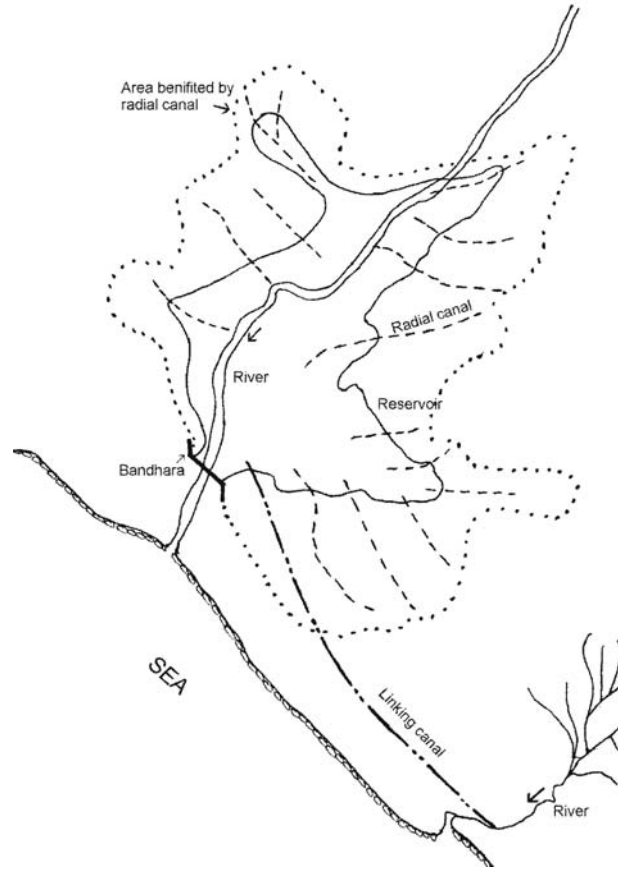

*Fig. 10.17 Map showing location of linking canal, radial canal and bandhara.*

# 11 REUSE OF WATER

## 11.1 INTRODUCTION

World has witnessed rapid economical growth, urbanization, and population growth and that has developed serious environmental concerns range from pollution largely urban and industrial, to resource management of water, land, forests, and energy.

A common approach used to evaluate water availability is the water stress index, and is measured as the annual renewable water resources per capita that are available to meet needs for domestic, industrial, and agricultural use. Projections predict that in 2025, two-thirds of the world's population will be under conditions of moderate to high water stress and about half of the population will face real constraints in their water supply. This includes numerous nations with adequate water resources, but also has arid regions where drought and restricted water supply are common (north-western China, western and southern India, large parts of Pakistan and Mexico, the western coasts of the US and South America, and the Mediterranean region).

It is essential that about 80% of wastewater in developing countries is used in irrigation. The double "R" mainly reclamation and reuse of wastewater belong to concept of clean technology and have been practiced in many parts of the world. Table 11.1 shows global data on wastewater irrigation practice in past two decades especially in semi-arid areas of both developed and developing countries.

**Table 11.1 Global data on wastewater irrigation practice**

<i>Country &amp; City</i>	<i>Irrigated Area (ha)</i>	<i>Country &amp; City</i>	<i>Irrigated Area (ha)</i>
Argentina, Mendoza	3700	Peru, Lima	6800
Australia	10,000	Saudi Arabia, Riyadh	2850
Bahrain, Tubli	800	South Africa, Johannesburg	1800
Chile, Santiago	16,000	Sudan, Khartoum	2800
China, all cities	13,30,000	Tunisha, Tunis	4450
Federal Rep of Germany Braunschweig	3000	Tunisha, other cities	2900
Germany, Other cities	25,000	USA, Chandler, Arizona	2800

*Contd.*

Country & City	Irrigated Area (ha)	Country & City	Irrigated Area (ha)
India, Kolkata	12,500	Bakersfield, California	2250
India, all cities	72000	Fresno, California	1625
Isreal, several cities	8800	Santarosa, California	1600
Kuwait, all cities	250000	Lubbock, Texas	3000
Maxico, Maxico city	90000	Muskegon, Michigan	2200

**Table 11.2 Status of wastewater generation (w/w), collection, and treatment in class I cities and class II towns (million liters per day)**

Type	Number of Cities/Towns	W/w Generated (mld)	W/w Collected (mld)	%age of w/w Collected	W/w treated (mld)	%age of w/w Treated (of Collected)	%age of w/w Treated (of Total)
Class I cities	299	16662.5	11938.2	72	4037.2	33.8	24
Class II towns	345	1649.6	1090.3	66	61.5	5.6	3.7
Total	644	18312.1	13028.5	71	4098.7	31.5	22.4

**Table 11.3 Status of wastewater (w/w) generation, collection, and treatment in major contributing states (million litres per day)**

State	Number of type	W/w generated Cities/Towns	W/w colleted (mld)	% age w/w Collected (mlf)	W/w treated (mld)	% age w/w Collected	Treated (mld)
Gujarat	Class I	21	1175.80	936.70	78.60	676	51.30
	Class II	27	191.20	137.80		25	
Maharashtra	Class I	27	3593.40	3139.00	85.60	481.4	13.3
	Class II	28.00	160.40	73.80		18	
Uttar Pradesh	Class I	41	1557.70	1048.90	66.70	246.2	13.4
	Class II	45	275.50	174.00		-	
West Bengal	Class I	23	1623.10	1183.00	72.20	-	
	Class II	18	66.90	36.70		-	
Delhi	Class I	1	2160.00	1270.00	58.80	1270	58.8
Total		231	10804.00	8000.00	74.04	2716.6	25.14

Potable water has become an extremely precious commodity in many areas of India, whether rural or urban. Pressure of growing populations in cities has increased the demand for water, but the development of additional water resources has not kept pace. Demand and deficit for a few major cities in India are presented in Table 11.4 below:

**Table 11.4 Demand and deficit for a few major cities in India**

<i>Metropolitan City</i>	<i>Demand (mld)</i>	<i>Deficit (mld)</i>
Delhi	3830	880
Hyderabad	1100	250
Mumbai	4000	1030
Chennai	300	165
Bangalore	840	175
Bhopal	335	70
Kolkata	2258	690
Jaipur	349	313

Water has always been used and reused by man. The natural water cycle, evaporation and precipitation, is one of reuse. Cities and industries draw water from surface streams and discharge wastes into the same streams, which, in turn, become the water supplies for downstream users. In the past, dilution and natural purification were usually sufficient for such system to perform satisfactorily, but, in recent years, population and industrial growth have made it evident that wastewater must be treated before discharge to maintain the quality of the stream.

## 11.2 CONCEPT OF REUSE OF WATER

The reuse of treated effluents is most applicable where large volumes of water are used and the wastes are not too contaminated. Industrial wastes may be heavily contaminated and therefore may not offer much potential for the recovery of clean water. The location of the treatment plant and the possible transport of the renovated water are important considerations. Treatment processes work most efficiently and economically when dealing with a steady flow of wastewater, rather than with the irregular flow normally experienced from urban sources.

Wastewater reclamation is the treatment or processing of wastewater to make it reusable, and water reuse is the use of treated wastewater for a beneficial use such as agricultural irrigation and industrial cooling. In addition, direct wastewater reuse requires existence of pipes or other conveyance facilities for delivering reclaimed water. Indirect reuse, through discharge of an effluent to receiving water for assimilation and withdrawals downstreams, is recognized to be important but does not constitute planned direct water reuse. In contrast to direct water reuse, water recycling normally involves only one use or user and the effluent from the user is captured and redirected back into that use scheme. In this context, water recycling is predominantly practiced in industry such as in pulp and paper industry (Metcalf & Eddy, 1991).

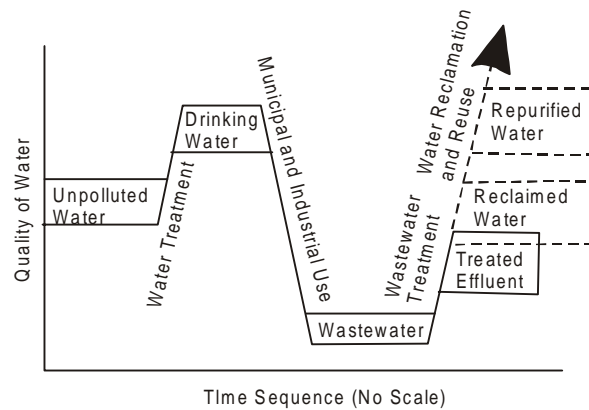

**Fig. 11.1** Quality changes during municipal use of water and the concept of wastewater reclamation and reuse. (Mc Gauhey, 1968)

Figure 11.1 shows, conceptually, the quality changes during municipal use of water in a time sequence. Through the process of water treatment, a drinking water is produced which has an elevated water quality meeting applicable standards for drinking water. The municipal and industrial uses degrade water quality, and the quality changes necessary to upgrade the wastewater then becomes a matter of concern of wastewater treatment. In the actual case, the treatment is carried out to the point required by regulatory agencies for protection of other beneficial uses. The dashed line in Fig. 11.1 represents an increase in treated wastewater quality as necessitated by wastewater reuse. Ultimately as the quality of treated wastewater approaches that of unpolluted natural water, the concept of wastewater reclamation and reuse is generated (McGauhey, 1968). Further advanced wastewater reclamation technologies, such as carbon adsorption, advanced oxidation, and reverse osmosis, will generate much higher quality water than conventional drinking water, and it is termed *repurified water*. Today, technically proven wastewater reclamation or purification processes exist to provide water of almost any quality desired.

Domestic reuse offers the best recycle opportunity, but, even then, the amount of water recycled falls short of the total amount of water used. The wastewater arriving at the treatment plant is generally found to be less than the amount originally supplied to the municipal water system. Losses occur, and they may be quite large in warm dry areas, where domestic reuse is most likely to be practiced.

Another consideration is the character of the wastewater entering the renovation plant, especially if this waste includes some industrial pollutants. Care should be taken to exclude materials that would be detrimental to the application for which the reclaimed water is to be used. This is especially true for the domestic reuse. Such materials may not be only those usually considered toxic. Ordinary salt brines, for example, are undesirable if the renovated wastewater is to be demineralized. A survey of the sewer system will determine how much of the available wastewater could be reused. Water highly contaminated with metals or containing a high total concentration of dissolved solids may be unacceptable Fig. 11.2. Treated wastewater

may be deliberately used in a planned way for a variety of purposes some of which are shown in Fig. 11.3. Intentional reuse is not new, but there is a growing recognition of the need for it.

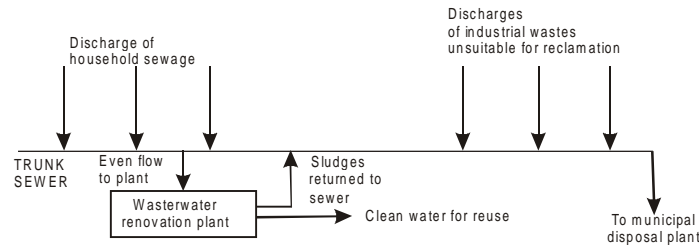

Fig. 11.2 Simplified wastewater reuse scheme.

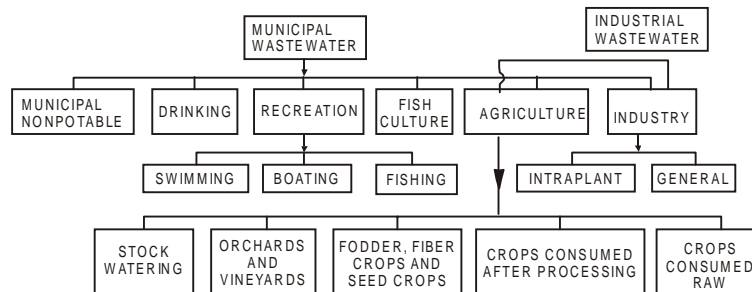

Fig. 11.3 Intentional reuse of wastewater.

### Definitions

**Municipal wastewater:** The spent water of a community: it consists of water that carries wastes from residences, commercial buildings, and industrial plants and surface or groundwater that enter the sewerage system.

**Indirect reuse:** Indirect reuse of wastewater occurs when water already used one or more times for domestic or industrial purposes is discharged into fresh surface or underground water and is used again in its diluted form.

**Direct reuse:** The planned and deliberate use of treated wastewater for some beneficial purpose, such as irrigation, recreation, industry, the recharging of underground aquifers, and drinking. In-plant water recycling: The reuse of water within industrial plants for conservation and pollution control purposes.

**Industrial wastewater:** The spent water from industrial operations, which may be treated and reused at the plant, discharged to the municipal sewer, or discharged partially treated or untreated directly to surface water.

**Advanced waste treatment:** Treatment systems that go beyond the conventional primary and secondary processes. Advanced waste treatment processes usually involve the addition of chemicals (biological nitrification — denitrification, the use of activated carbon), filtration, or separation by use of membranes.

### 11.3 CATEGORIES OF WASTEWATER REUSE

In the planning and implementation of wastewater reclamation and reuse, the intended wastewater reuse applications govern the degree of wastewater treatment required and the reliability of wastewater treatment processing and operation. In principle, wastewater or any marginal quality water can be used for any purpose provided that they meet the water quality requirements for the intended use. Seven categories of reuse of municipal wastewater are identified in Table 11.5, along with the potential constrains. Large quantities of reclaimed municipal wastewater have been used in four reuse categories: agricultural irrigation, landscape irrigation, industrial recycling and reuse, and groundwater recharge.

In California, where the largest number of wastewater reclamation and reuse facilities have been developed, at least 432 million cubic meters ( $10^6 \text{ m}^3$ ) of municipal wastewater are beneficially used annually. This figure corresponds to around 8 per cent of municipal wastewater generated in the State (State of California, 1990).

In Japan, there were 876 publicly owned treatment works (POTWs) operating in 1991, discharging approximately  $110 \times 10^6 \text{ m}^3/\text{year}$  of secondary treated effluents. Of these approximately  $100 \times 10^6 \text{ m}^3/\text{year}$  of reclaimed wastewater from 99 POTWs are reused beneficially in such uses as industrial uses (41%), environmental water and flow augmentation (32%), agricultural irrigation (13%), non-potable urban use and toilet flushing (8%), and seasonal snow-melting and removal (4%) (Asano et al., 1996).

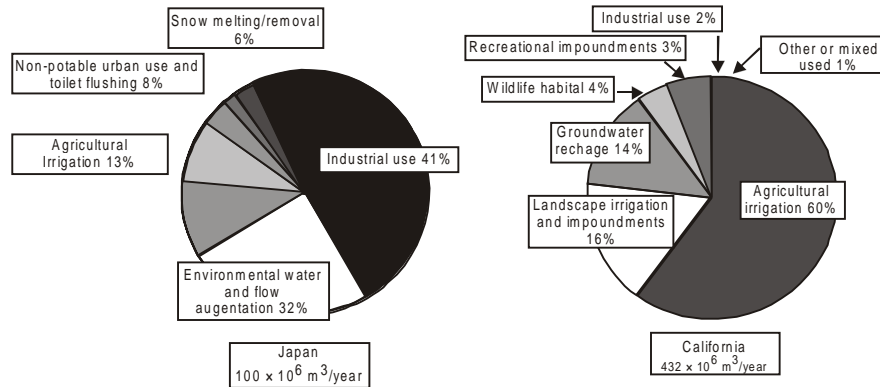

Fig. 11.4 Types and volume of wastewater reuse in California and Japan.

Contrary to the arid or semi-arid regions of the world where agricultural and landscape irrigation are the major beneficial use of reclaimed wastewater. Wastewater reuse in Japan is dominated by the various non-potable, urban uses such as toilet flushing, industrial use, stream restoration and flow augmentation to create so called “urban amenities”. Figure 11.4 shows the comparative diagrams for Japan and California, depicting the various reclaimed water uses and the corresponding volumes per year (State Water Resources Control Board, 1990; Japan Sewage Works Association, 1994).

**Table 11.5 Categories of municipal wastewater reuse and potential issues/constraints**

<i>Wastewater Reuse Categories</i>	<i>Issues/Constraints</i>
Agricultural irrigation Crop irrigation Commercial nurseries Landscape irrigation Parks School yards Freeway medians Golf courses Cemeteries Greenbelts Residential	(1) Surface and groundwater pollution if not managed properly. (2) Marketability of crops and public acceptance, (3) effect of water quality, particularly salts, on soils and crops, (4) public health concerns related to pathogens (bacteria, viruses, and parasites), (5) use for control of area including buffer zone, (6) may result in high user costs.
Industrial recycling and reuse Cooling water Boiler feed Process water Heavy construction	(1) Constituents in reclaimed wastewater related to scaling corrosion, biological growth, and fouling, (2) public health concerns, particularly aerosol transmission of pathogens in cooling water.
Groundwater recharge Groundwater replenishment Salt water intrusion control subsidence control	(1) Organic chemicals in reclaimed wastewater and their toxicological effects, (2) total dissolved solids, nitrates, and pathogens in reclaimed wastewater.
Recreational/environmental uses Lakes and ponds Marsh enhancement Streamflow augmentation Fisheries Snowmaking	(1) Health concerns of bacteria and viruses, (2) eutrophication due to nitrogen (N) and phosphorus (P) in receiving water, (3) toxicity to aquatic life.
Non-potable urban uses Fire protection Air conditioning Toilet flushing Potable reuses Blending in water supply Pipe to pipe water supply	(1) Public health concerns on pathogens transmitted by aerosols, (2) Effects of water quality on scaling, corrosion, biological growth, and fouling, (3) Cross-connection.  (1) Constituents in reclaimed wastewater, especially trace reservoir organic chemicals and their toxicological effects, (2) aesthetics and public acceptance, (3) health concerns about pathogen transmission, particularly viruses.

### **Composition of Wastewaters**

Unpolluted surface and groundwaters contain various minerals and gases depending upon the geology and surface terrain. Use of water by a city adds a variety of materials such as grit, dirt, oil, bacteria, fertilizer, pesticides and miscellaneous organic matter from streets or land erosion; human waste (organic matter, bacteria, viruses, salts); laundry waste (inorganic salts, phosphates, salts, surfactants); industrial waste (heat, inorganic salts, colour, metals, organics, toxic materials, oils, and the product itself). Even with the myriad materials in wastewaters, municipal wastes are 99.9% water.



Because of the many materials in wastewater at very low concentrations, it is impracticable to measure all of them. Measurement of classes of contaminants has become the rule; thus, the measure of the organic matter in sewage relies upon the biochemical oxygen demand (BOD) and the chemical oxygen demand (COD) and the total organic carbon (TOC). The BOD measures the oxygen required by organisms, the COD measures the oxygen required to chemically oxidize the organics, and the TOC directly measures the organic carbon. Determinations of solids are relatively easy. The microbiological characteristic principally depends upon measuring the coliform group of bacteria.

As wastewater reuse increases, it will be necessary to measure and monitor the water quality to a much greater degree. Good progress is being made in this field of work.

#### ***Outline for wastewater reclamation and reuse facilities plan***

The planning efforts for wastewater reclamation and reuse facilities are as under:

**Study area characteristics:** Geography, geology, climate, groundwater basins, surface waters, land use, population growth.

**Water supply characteristics and facilities:** Agency jurisdiction, sources and qualities of supply, description of major facilities, water use trends, future facilities needs, groundwater management and problems, present and future freshwater costs, subsidies and customer prices.

**Wastewater characteristics and facilities:** Agency jurisdiction, description of major facilities, quantity and quality of treated effluent, seasonal and hourly flow and quality variations, future facilities needs, need for source control of constituents affecting reuse, description of existing reuse (users, quantities, contractual and pricing agreements).

**Treatment requirements for discharge and reuse and other restrictions:** Health and water quality related requirements, user-specific water quality requirements, use area controls.

**Potential water reuses customers:** Description of market analysis procedures, inventory of potential reclaimed water users and results of user survey.

**Project alternative analysis:** Capital and operation and maintenance costs, engineering feasibility, economic analysis, financial analysis, energy analysis, water quality impacts, public and market acceptance, water rights impacts, environmental and social impacts, comparison of alternatives and selection.

**Recommended plan:** Description of proposed facilities, preliminary design criteria, projected cost, list of potential users and commitments, quantity and variation of reclaimed water demand in relation to supply, reliability of supply and need for supplemental or back-up water supply, implementation plan, and operational plan.

**Construction financing plan and revenue programme:** Sources and timing of funds for design and construction; pricing policy of reclaimed water; cost allocation between water supply benefits and pollution control purposes; projection of future reclaimed water use, freshwater prices, reclamation project costs, unit costs, unit prices, total revenue, subsidies; sunk costs and indebtedness; analysis of sensitivity to changed conditions.

#### 11.4 TECHNOLOGICAL INNOVATIONS

The contaminants in reclaimed wastewater that are of public health significance may be classified as biological and chemical agents. Where reclaimed wastewater is used for irrigation, biological agents including bacterial pathogens, helminthes, protozoa, and viruses pose the greatest health risks. To protect public health, considerable efforts have been made to establish conditions and regulations that would allow for safe use of reclaimed wastewater. Summaries of recommended microbiological quality guidelines by the World Health Organization (1989) and the State of California's Wastewater Reclamation Criteria (1978) are presented in Table 11.6. The WHO guidelines emphasize the use of a series of stabilization ponds for producing an acceptable microbial water quality; whereas, the California criteria stipulate conventional biological wastewater treatment, filtration, and chlorine disinfection.

Of the known water-borne pathogens, enteric viruses have been considered the most critical in wastewater reuse in the developed world because of the possibility of infection with low doses and difficulty of routine examination for their presence. Thus, essentially pathogen-free effluent via secondary treatment and tertiary treatment including chemical coagulation, flocculation, filtration, and disinfection is necessary for reclaimed wastewater applications with higher potential exposures; e.g., spray irrigation of food crops eaten uncooked, parks and playgrounds, and unrestricted recreational impoundments.

Because of the stringent water quality requirements imposed upon such water reuse applications, the importance of granular-medium filtration, as a tertiary treatment step, has been demonstrated. The filtration removes substantial numbers of particles in wastewater; thus, promotes effective disinfection as well as esthetic enhancement of reclaimed water for beneficial uses. Figure 11.5 shows schematic diagram of full treatment as well as less costly alternatives, contact and direct filtration.

**Table 11.6 Summaries of recommended microbiological quality guidelines and criteria by the World Health Organization (1989) and the State of California's Wastewater Reclamation Criteria (1978)**

Category	Reuse Conditions	Intestinal Nematodes, Eggs/L (a)	Fecal Coliforms (cfu/100mL) (b) or Total Coliforms (NMP/100mL) (c)	Wastewater Treatment Expected to Achieve that Microbiological Quality
WHO	Irrigation of crops likely to be eaten uncooked, sports fields, public parks	≤ 1	≤ 1000	A series of stabilization ponds or equivalent treatment
California	Spray and surface irrigation of food crops, high exposure landscape irrigation such as parks	No standard recommended	≤ 2.2	Secondary treatment followed by filtration and disinfection

Contd...

Category	Reuse Conditions	Intestinal Nematodes, Eggs/L (a)	Fecal Coliforms (cfu/100mL) (b) or Total Coliforms (NMP/100mL) (c)	Wastewater Treatment Expected to Achieve that Microbiological Quality
WHO	Irrigation of cereal crops, fodder crops, pasture and trees	No standard recommended	≤ 1	Retention in stabilization ponds for 8–10 days or equivalent removal
California	Irrigation of pasture for milking animals landscape impoundment	No standard recommended	≤ 23	

(a) Intestinal nematodes, expressed as the arithmetic mean number of eggs per litre during the irrigation period. (b) WHO recommends a more stringent guideline (<200 fecal coliforms/100mL) for public lawns, with which the public may come into direct contact. (c) California Wastewater Reclamation Criteria is expressed as the median number of total coliforms per 100mL as determined from the bacteriological results of the last 7 days for which analyses have been completed

To protect the environment and to maximize reuse opportunities, discharge requirements for treated wastewater for small discharges are now the same as those for large dischargers. The challenge is to be able to provide the required level of treatment in decentralized systems, subject to serious economic constraints. Alternative wastewater management technologies for unsewered areas are reported in Table 11.7.

**Table 11.7 Technologies used for decentralized wastewater management systems**

Collection and Transport of Wastewater	Wastewater Treatment and/or Containment	Wastewater Disposal/Reuse
House drains and building sewers	Primary treatment Septic tank (individual, home, home cluster, and community)	Subsurface soil disposal Leach fields Conventional
Conventional gravity sewers	Imhoff tank	Shallow trench Shallow sand-filled
Pressure sewers (With non-grinder pumps)	Advanced primary treatment Septic tank with attached growth reactor element	Seepage beds Mound systems Evapotranspiration/percolation beds
Pressure sewers (With grinder pump)	Secondary treatment Aerobic/anaerobic units	Drip application
Small-diameter slope gravity sewers	Anaerobic units Two-stage anaerobic/aerobic units with disinfection (used in Japan)	Evaporation systems Evapotranspiration bed Evaporation pond
Vacuum sewers	Intermittent sand filter	Constructed wetlands (marsh)

Contd...

<i>Collection and Transport of Wastewater</i>	<i>Wastewater Treatment and/or Containment</i>	<i>Wastewater Disposal/Reuse</i>
Combinations of the above	Recirculating granular medium filter (sand, crushed glass) Peat filter Constructed wetlands Recycle treatment systems Toilet flushing Landscape watering and toilet flushing Onsite containment Holding tank Privy	Land disposal  Surface application Drip application Discharge to water bodies  Combinations of the above

A. Full Treatment (Title 22)

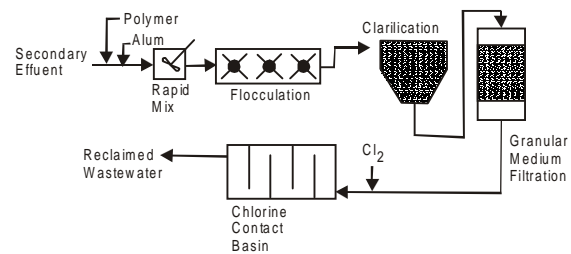

B. Direct Filtration

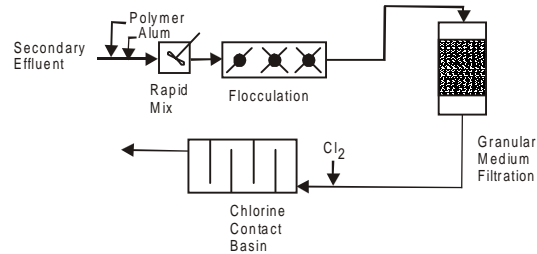

C. Contact Filtration

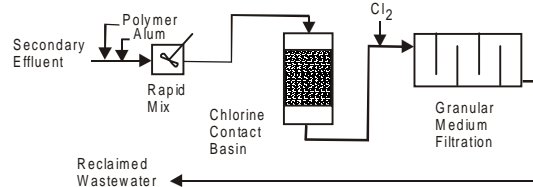
**Fig. 11.5 Schematic diagram of filtration systems using wastewater reclamation and reuse**

## 11.5 TYPES OF WASTEWATER REUSE

**Direct reuse:** It involves transmission of wastewater treated or untreated directly to some specific intended use, by means of pipes or other conveyance facilities for delivering reclaimed water. No natural buffers such as lakes, rivers or ground water serve as intermediaries to

expose wastewater to natural purification and dilution system. (e.g. Irrigation for agriculture, parks, golf courses, lawns, processing and cooling water for industries, recreational water ponds like swimming, boating, fishing etc).

**Indirect reuse:** Here effluent is discharged to receive water for assimilation and withdrawal downstream. It involves natural buffer as an intermediary stage and includes greater temporal and spatial separation of treatment and reuse. Greater time provides opportunity for monitoring and testing water quality before use and spatial separation allows for dilution and improvement in aesthetic property of water. (e.g. Ground water recharge, upstream disposal. Chennai refineries Ltd., gets effluent from the city's sewer unit plants and use it as their process water after treating the sewage by biological and advanced treatment methods like ion exchange and reverse osmosis).

**Inadvertent/unplanned reuse:** As the name suggests, occurs when water is withdrawn, used by one party, returned to a water source (e.g. lake, river, aquifer) without specific intention or planning to provide water for use of other parties.

**Planned reuse:** Involves collection and purposeful provision of wastewater for subsequent use.

**Potable reuse:** Planned direct or indirect reuse for some beneficial purposes (e.g. drinking, cooking, bathing, laundry etc.).

**Non-potable reuse:** Inadvertent indirect reuse (e.g. fire fighting, toilet flushing etc.). Depending upon the intended wastewater reuse application, municipal wastewater reuse is categorized along with the potential constraints in Table 11.8.

**Table 11.8 Wastewater reuse and constraints**

<i>Wastewater Reuse</i>	<i>Potential Constraints</i>
Agricultural irrigation — crop irrigation, commercial nurseries. Landscape irrigation — park, schoolyard, golf course, and greenbelt, residential. Industrial reuse — cooling, boiler feed, process water, heavy construction. Groundwater recharge Recreational and environmental uses — lakes, ponds, marsh enhancement, fisheries, snowmaking. Nonpotable urban uses — fire protection, air conditioning, toilet flushing. Potable reuse — blending in water supply	Effect of water quality, particularly salts on soils and crops. Public health concerns related to pathogens, surface and groundwater pollution, marketability and public acceptance. Water constituents related to scaling, corrosion, etc., public health concerns, particularly aerosol transmission of organics and pathogens in cooling and process water. Trace organics and toxins in reclaimed water. Public health concerns, aesthetics due to odour. Public health concerns, effects of water quality on scaling, corrosion, fouling etc. Trace organic, toxins, aesthetics and public acceptance, and public health.

### ***Irrigation Reuse***

Reusing of Municipal wastewaters for irrigation is the oldest and largest reuse. Advanced treatment of wastewaters is not always required, but each potential reuse should be thoroughly analyzed to determine the quality required. The advantages and the reuse of treated wastewater for irrigations are:

1. Low-cost source of water.
  2. An economical way to dispose of wastewater to prevent pollution and sanitary problems.
  3. An effective use of plant nutrients content in wastewater.
  4. Providing additional treatment before being recharge to the groundwater reservoir.
- When wastewater is used for irrigation, a number of possible disadvantages have to be considered:

1. The supply of wastewater is continuous throughout the year, while irrigation is seasonal and dependent on crop demands.
2. Treated wastewater may plug nozzles in irrigation systems and clog capillary pores of heavy soils.
3. Some of the soluble constituents in wastewater may be present in concentrations toxic to plants.
4. Health regulations restrict the application of wastewater to edible crops.
5. When wastewater is not properly treated, it may be a nuisance to the environment.

Current standards for irrigation water are compared to those of WHO and the USEPA for urban reuse in Table 11.9.

**Table 11.9 Comparison of agricultural reuse guidelines**

<i>Parameter</i>	<i>India Irrigation</i>	<i>WHO (A)</i>	<i>EPA Food Crop</i>	<i>EPA Non-food Crop</i>
Fecal coliform	NS	≤ 1000	Nil	≤ 200
Intestinal nematodes	NS	≤ 1	NS	NS
BOD <sub>5</sub>	≤ 100	NS	≤ 10	≤ 30
Suspended solids	≤ 200	NS	≤ 30	≤ 30
Residual chlorine	NS	NS	≥ 1	≥ 1
TDS	≤ 2100	NS	NS	NS
NS = No Standard				

### ***Recreational Reuse***

Reuse of wastewater in recreational lakes is becoming increasingly popular in the arid areas of the United States. The state of California has pioneered in recreational reuse, with several lakes in existence for a number of years. Lakes at Santee and Indian Creek Reservoir near Lake Tahoe are probably the best known. Tuscon, Arizona is installing recreational lakes derived from treated wastewaters.

Wastewater used in recreational lakes must satisfy both health standards and standards that will make the lake acceptable from the recreational purposes. Although there are no

national public health standards, at least one state, California, has written standards that can be used as an example. For unrestricted recreational use, wastewater in California must be biologically treated, chemically flocculated, filtered to produce a turbidity of not more than 10 turbidity units, and adequately disinfected. Adequate disinfection is defined as 2.2-coliform/100 ml. The mean is determined over a 7 days period. These standards were arrived at after several years of careful observations, including monitoring for viruses.

The public health standards cannot be used alone to define an adequate treatment system, since they do not deal in detail with problems related to ammonia in the water. Limiting the amount of the major nutrients (generally involves phosphorus or nitrogen, or both) can control excessive algae growth.

For cost-estimating purposes, Fig. 11.6 shows a treatment system that should satisfactorily produce recreational lake water. The system includes conversion of nitrogen to nitrate and phosphorus removal down to the level of about 0.1 mg/lit, as P. Organic removal should be excellent because of the two-stage biological treatment and filtration suspended solids in the treated water should be almost zero.

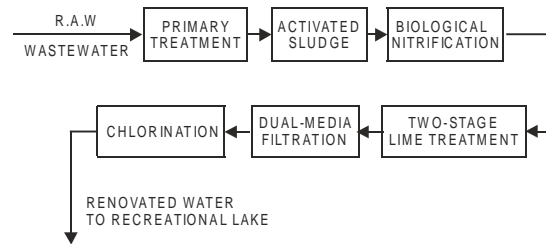

**Fig. 11.6 Treatment system for producing recreational lake water.**

### **Sewage and Industrial Waste reuse**

Industrial use of municipal wastewater has been practiced for some time. Early examples in the United States include the Bethlehem Steel Company at Baltimore, Maryland, and the Nevada Power Company at Las Vegas, Nevada. Until recently, nearly all of the reuse was for cooling water. Interest in using the wastewater for other industrial purposes is increasing. In the United States, it has been characteristic of industrial reuse that one plant only uses the effluent from a given sewage treatment plant. This occurs because the need for large volumes of cooling water and the one plant can use a significant fraction of the treatment plant output. The result is a very simple distribution system. Because of the cost of distribution system, this tendency towards a small number of users, probably located close to the treatment plant, is likely to continue.

Because there are many possible industrial uses for renovated wastewater, a wide variety of treatment systems might be employed. Secondary effluent with no further treatment has been used in some cases for cooling purposes. Calcium phosphate scale problems are likely, however, when no precautions are taken for phosphate removal. For most reuse situations, especially those involving more than a single user, it is unlikely that secondary treatment alone will be satisfactory. Chemical clarification with a phosphorous precipitating chemical would significantly improve the acceptability of the water from both the standpoint of phosphorus content and turbidity. Figure

11.7 shows a treatment that should have widespread usefulness. Nitrification could be included if ammonia is a problem. Clarification could be carried out with lime, aluminium salts, or iron salts. Lime, however, would appear to have several advantages over the other materials: it does not add extraneous ions such as chloride or sulfate; it removes some heavy metals; and it produces water that is less likely to be corrosive. If clarification were carried out with good solids control, filtration would not be required. For the relatively small additional cost, however, its inclusion significantly increases dependability. At Las Vegas, a system using lime treatment is followed by a holding pond rather than a filter. The pond is very effective for solids control.

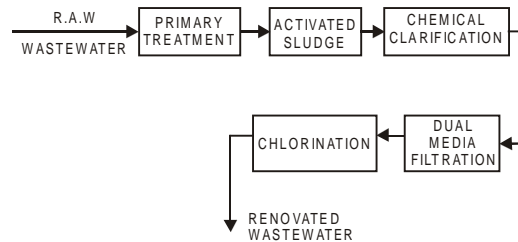

Fig. 11.7 Treatment system for producing industrial water.

Manufacturing produces large quantities of BOD. The major contributors are the chemical industry, the pulp and paper industry, and the food processing industries. Table 11.10 lists typical BOD and suspended solids levels produced by a variety of industries.

Table 11.10 Typical process waste strengths

Type of Industry	Process Wastes (mg/l)	
	BOD	Suspended Solids
Petroleum refining	310	370
Leather and leather products	1300	1700
Flat glass	310	370
Concrete, gypsum and plastic products	310	10000
Primary metal industries	310	370
Industrial launderers	870	1100
Meat products	800	520
Dairy products	2100	370
Preserved fruits and vegetables	1400	370
Grain mill products	3200	4500
Bakery, mixed	2500	1100
Fats and oils	1300	1100
Seafood and fish	1400	600
Food preparations	4100	930
Medicinal and botanicals, fermentation	4500	4700
Paints and allied products	2500	600
Industrial organic chemicals	310	370
Miscellaneous chemical products	2500	2600

Source: Sell, 1992 (sell, N J (1992) *Industrial Pollution Control: Issues and Technologies*. Van Nostrand Reinhold Publishing Co. Inc, New York.



Pollutants of concern in wastewater, if reuse is considered, are listed in Table 11.11 where the different classes of industrial wastewater pollutants are categorized along with measured parameters and potential reuse concerns.

**Table 11.11 Constituents of concern in wastewater effluent**

<i>Constituent</i>	<i>Measured Parameter</i>	<i>Reason for Concern</i>
Suspended solids	Suspended solids including volatile and fixed solids	Suspended solids can lead to the development of sludge deposits and anaerobic conditions when untreated wastewater is discharged in the aquatic environment. Excessive amounts of suspended solids cause plugging in irrigation systems.
Biodegradable organics	BOD, COD	Composed principally of proteins, carbohydrates, and fats, if discharged into the environment, their biological decomposition of biodegradable organics can lead to the depletion of dissolved oxygen in receiving waters and to the development of septic conditions.
Pathogens	Indicator organisms, and total and fecal coliform bacteria	Communicable diseases can be transmitted by pathogens in wastewater, bacteria, virus, and parasites.
Nutrients	Nitrogen, and potassium	Nitrogen, phosphorus and potassium are essential nutrients for plant growth, and their presence normally enhances the value of the water for irrigation. When discharged to the aquatic environment, nitrogen and phosphorus can lead to the growth of undesirable aquatic life. When discharged in excessive amounts on land, nitrogen can also lead to the pollution of groundwater.
Stable (refractory) organics	Specific compounds (e.g. phenols, pesticides, and chlorinated hydrocarbons).	These organics tend to resist conventional methods of wastewater treatment. Some organic compounds are toxic in the environment, and their presence may limit the suitability of the wastewater for irrigation.
Hydrogen ion activity	pH	The pH of wastewater affects metal solubility. The normal pH range in municipal wastewater is 6.5 – 8.5, but industrial waste can alter pH significantly.
Heavy metals	Specific elements (e.g., Cd, Zn, Ni, and Hg)	Some heavy metals accumulate in the environment and are toxic to plants and animals. Their presence may limit the suitability of the wastewater for irrigation.
Dissolved inorganics	Total dissolved solids, electrical conductivity, and specific elements (e.g., Na, Ca, Mg, Cl, and B)	Excessive salinity may damage some crops. Specific ions such as chloride, sodium, and boron are toxic to some crops. Sodium may pose soil permeability problems.
Residual chlorine	Free and combined chlorine	Excessive amount of free available chlorine (0.05 mg/l Cl <sub>2</sub> ) may cause leaf-tip burn and may damage some sensitive crops. However, most of the chlorine in reclaimed wastewater is in a combined form, which does not cause crop damage. Some concerns are expressed as to the toxic effects of chlorinated organics in regards to groundwater contamination.

Source: Papadopoulos I, 1992: Rehabilitation of the areas irrigated with wastewater in the state of Kuwait. Assignment report, World Health Organization.

Large cities generate large quantities of sewage. In most cities, the sewage is treated and discharged as treated water. In the present situation most of the treated sewage is used for farming. The treated sewage can also be used by industry as an alternate source of water. Depending on the use of treated water in an industry, the secondary treated sewage may have to be subjected to further treatment termed as *Tertiary treatment*. Various unit operations such as clarification, filtration, and chemical treatment desalination may be incorporated in the treatment scheme to produce desired quality of water for reuse. Sewage generally contains low concentration of impurities and most of the pollutants being of organic nature. It is treated at low cost using naturally available micro-organism and conventional methods of clarification, filtration and chlorination. The treated sewage can be used by industries as cooling tower make-up. In case the industry needs water with low dissolved solids, for use as process water boiler feed water, or as replacement of raw water, the sewage after secondary and tertiary treatment may be treated by technologies such as RO or EDR to produce high quality water. In most cases, where industry is buying water from industrial development corporations or state government, implementation of sewage reuse is economically viable. Sewage reuse plants have already been adopted by industry in Chennai (Chennai Refineries Ltd., Madras Fertiliser Ltd.), and by Rashtriya Chemical & Fertilizer Ltd., in Mumbai.

Industrial wastewater is the other source of water for reuse. As compared to sewage reuse, the industrial wastewater reuse system is slightly expensive. This is because the industrial waste is more completed to treat. On the other hand, operation of industrial waste reuse plant is more dependable as constant quality wastewater is available at the outlet of existing Effluent Treatment Plant. For ready reference a case study to indicate technocommercial feasibility of using sewage as industrial water is given hereunder as case A.

**Case Study A – Feed and treated water quality (colony sewage)**

Parameters		Feed	Treated sewage for cooling tower makeup
pH		7 – 8	7 – 8
COD	mg/l	250 – 300	< 10
BOD	mg/l	180 – 200	< 3.5
Total suspended solids	mg/l	130 – 150	< 10
Total dissolved solids	mg/l	400 – 600	400–600

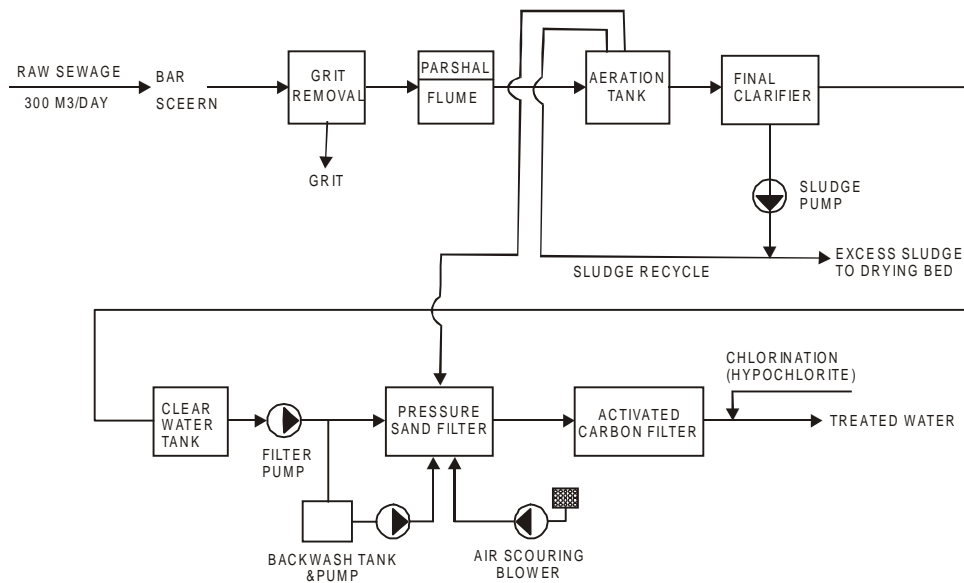

**Fig. 11.8 Reuse of domestic sewage as cooling tower makeup – Case study -A**

Industrial wastewater is the other source of water for reuse. As compared to sewage reuse, the industrial wastewater reuse system is slightly expensive. This is because the industrial waste is more complicated to treat. On the other hand operation of industrial waste reuse plant is more dependable as a constant quality wastewater. Two case studies (Case study B and C) are presented here to prove the point.

**Case study B – Feed and treated water quality (Low TDS industrial waste water)**

Parameters		Inlet Feed Quality	Treated Waste Water Quality
pH		6.0 – 9.50	7.0 – 7.5
Suspended solids	mg/l	200	> 5
Total dissolved solids	mg/l	250	250
Total hardness (CaCO <sub>3</sub> )	mg/l	200	200
Total alkalinity	mg/l	210 max	210 max
Chloride (as Cl)	mg/l	80 max	80 max
Phosphate	mg/l	15	15
Sulphate	mg/l	100 max	100 max
Silica (as SiO <sub>2</sub> )	mg/l	20 max	20
Oil and grease	mg/l	10 max	ND
TOC	mg/l	100 max	15 max
COD	mg/l	150 max	< 20
BOD	mg/l	30 max	< 2.0
Residual chlorine	mg/l	–	0.2– 0.6

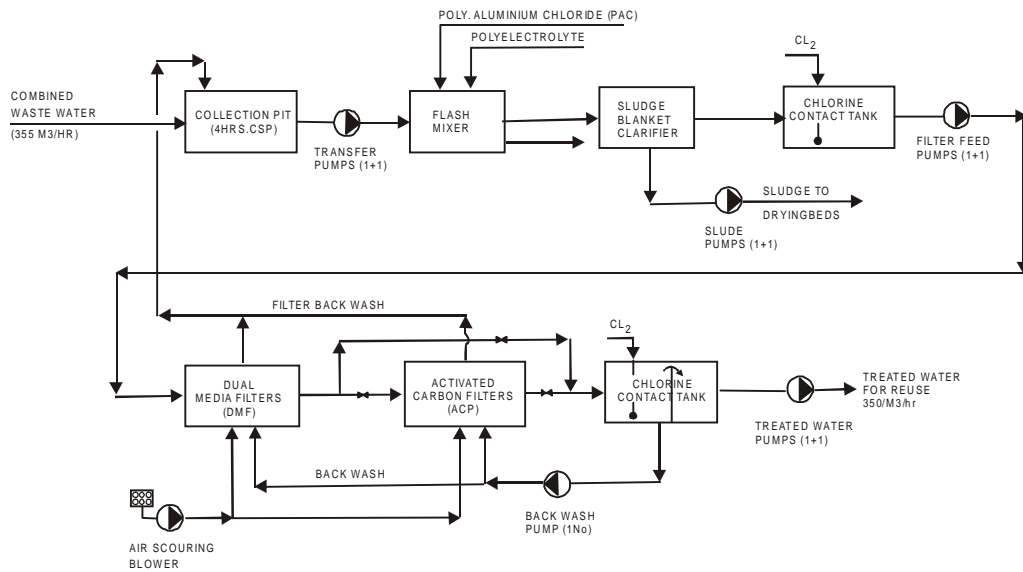
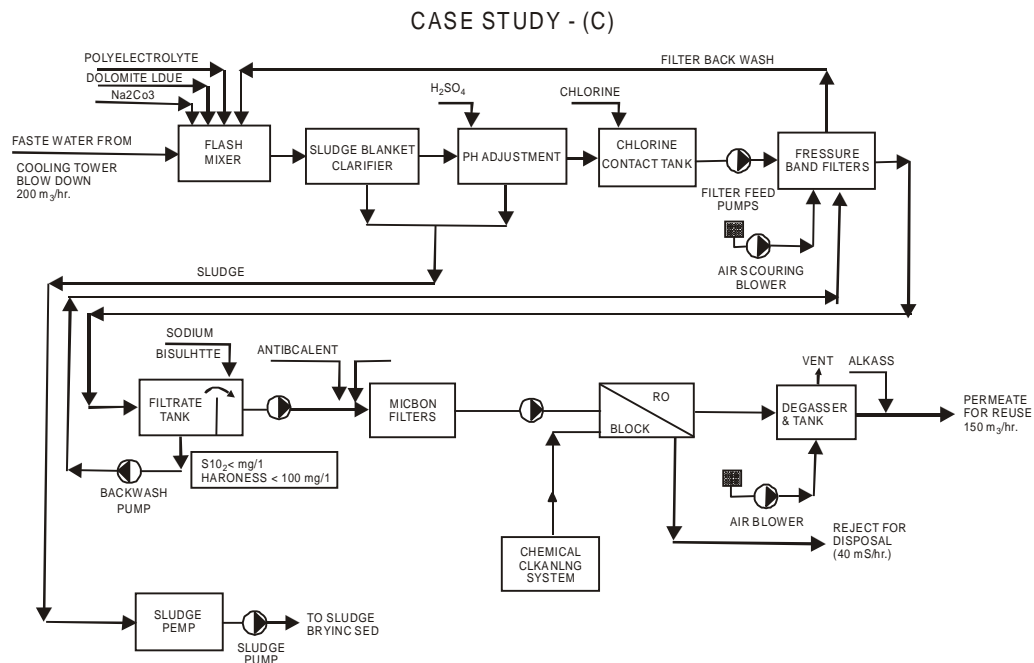

Fig. 11.9 Low TDS industrial wastewaters reuse system – Case study - B

**Case study C: Feed and treated water quality (Industrial cooling tower blowdown)**

Parameters		Feed	Treated water quality reuse as CT makeup
pH		7.4 – 7.8	7 – 7.2
Turbidity	NTU	3 – 5	1
Total dissolved solids	mg/l	1200 – 1400	< 200
Total hardness (CaCO <sub>3</sub> )	mg/l	500 – 600	< 100
Chloride	mg/l	200 – 260	< 25
Sulphates	mg/l	7 – 11	—
Phosphates	mg/l	300 – 500	—
Silica (as SiO <sub>2</sub> )	mg/l	105 – 120	< 20
Soluble iron	mg/l	0.1 – 0.2	—
Soluble zinc	mg/l	0.5 – 0.7	—
COD	mg/l	0 – 60	< 1
BOD	mg/l	—	< 1
Free chlorine	mg/l	< 0.5	< 0.5
Total ammonia (NH <sub>3</sub> )		10 - 50	< 10



**Fig. 11.10 Cooling tower blowdown reuse system – Case study - C**

### **Domestic Reuse of Non-potable Water**

Non-potable uses are not particularly new. At the Grand Canyon in Arizona, wastewater has been reused for toilet flushing for many years. Treatment consists of biological oxidation followed by filtration and chlorination. On Pikes Peak in Colorado, a novel treatment system was recently installed to produce water for various non-potable uses. It consists of a special pressurized, activated sludge system using a membrane for solids removal in place of the final settler.

Quality standards for non-potable reuse have not been set on a national level. Local health authorities are responsible for approval of these systems. The major concern is for pathogenic organisms. Therefore, adequate disinfection is of great importance.

Since these systems have been small and for very specialized situations making meaningful cost estimates are difficult. A large-scale system might consist of conventional biological treatment followed by filtration and chlorination.

Utilization of non-potable domestic reuse systems is and will be greatly restricted by the need for a complete dual distribution system. In large cities, the cost would probably be prohibitive; in small towns, however, dual systems may be practical. Such systems have been proposed in the mid Southwest.

### **Domestic Reuse of Near Potable Water**

There has been a great deal of talk about potable reuse, but little activity. The only long-term operation has been that at Windhoek, Southwest Africa (Namibia), reported on by Cillie et al. (1967) and Stnder and Funke (1967), where about one third of the municipal water supply is renovated wastewater.

Because of the limited experience with direct reuse of renovated wastewater, there are no standards to apply to such waters. Standards for drinking water such as those of the US Public Health Service (1962), apply to water sources that are as free as possible from pollution. Many in the water field believe that renovated wastewater should meet additional standards beyond those written for large unpolluted sources. The most important areas of concern are trace organic pollutant, metals, and pathogens, especially viruses. Analytical techniques to detect very low concentrations of organics and virus are in an early stage of development, are expensive, and are time consuming. Analyses for metals are sensitive and generally adequate.

One answer to the problem is to insist that the water be overtreated to a point at which there could be absolutely no doubt of the water purity, even in the absence of adequate analytical techniques. Such procedure may be tolerated in some cases to obtain potable water, but this would not be possible for large volume uses.

A system such as that shown in Fig. 11.11 might be used for demineralization step; this is very much like the advanced waste treatment plant at South Lake Tahoe, as it is presently operated. The product water from the system will meet the quantitative values of the US Public Health Service Drinking Water Standards. Although there is no standard for ammonia, nitrification would be necessary to reduce the ammonia concentration to aesthetically acceptable levels. Limited virus determinations from the Tahoe plant showed no virus recovery from the product water. Whether demineralization would be required, or to what degree, would depend upon the fraction of recycle and the mineral content of the make up water supply. A material balance would have to be made for each particular situation to determine demineralization requirements. A 40% total dissolved solids removal would probably cover most situations. Ion exchange is shown in the diagram as the method of demineralization because it presently appears to be as cheap as any other method and offers some degree of trace organic removal. Since ion exchange would probably be operated to give almost total removal of minerals, not all of the water would have to be treated. If demineralization were not included, there is a chance that the nitrate concentration would exceed the standard of 10 mg/lit, as nitrogen. In such cases, the necessary nitrate removal could be obtained by biological denitrification of part of the flow.

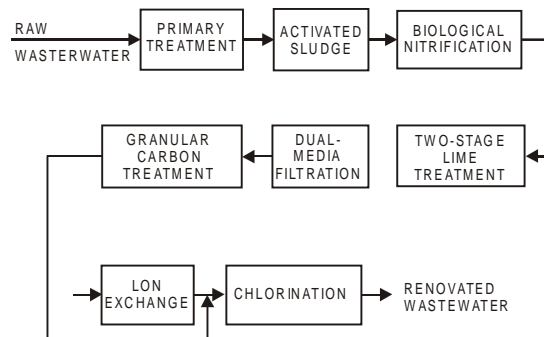

**Fig. 11.11 Treatment system for producing acceptably potable water.**

### Reuse of Water in Tall Buildings

A rather unusual application of reuse techniques is to be seen in nearly seven tall commercial buildings ranging from 20 to 25 stories that were constructed in recent years in Bombay. The need for such reuse stems from the need to fully air-condition the buildings. Cooling water is re-circulated through a mechanical draught tower located at the top of the building, and make-up water requirements amounting from 150 to 250 m<sup>3</sup>/day depending on the size of the building have to be obtained from sources other than municipal water supply because of acute shortage.

A way was soon found to meet this urgent need. Based on feasibility studies, it was shown that the most economical and dependable way of meeting these requirements was to take the sewage of the building itself to the basement for treatment in a compact plant to make it fit for reuse as cooling water. The building drain is carried to the basement with an arrangement for bypassing the sewage to municipal sewer if desired. Likewise, an arrangement is provided for tapping municipal sewage if necessary to augment the flow through the treatment plant. As the latter arrangement is not routinely used, the plant design has to take into account the fact that practically all the building wastewater is received within the usual office working hours, since these are mostly office buildings. Treated water thus needs to be stored (Fig. 11.12).

Raw sewage enters the aeration tank after screening. No grit removal is found necessary in these plants. The process adopted is the extended aeration process. Odour-free operation is most important at all times since the plant is located within the building. For the same reason, an anaerobic sludge digester with gas production would not be acceptable. In sizing the aeration tank and the units that follow the flow pattern of the incoming wastewater is kept in view.

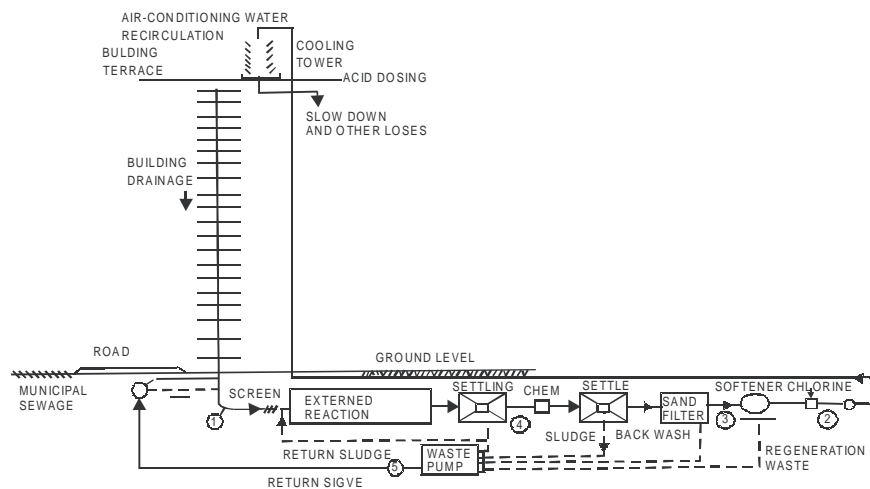

Fig. 11.12 Reuse of water in tall buildings – flowsheet

To determine the quality and quantity of water required for reuse in the tall buildings the following approach is followed: An open re-circulating system is generally adopted for air-conditioning cooling water and the amount of water to be kept re-circulating in the system is

approximately 11 liters/min for every ton of refrigeration capacity when temperature drop is 5°C in the cooling tower. For such a situation, the water lost in evaporation (E) is about 1% of the re-circulating water.

Windage loss (W) is of the order of 0.1 to 0.3% of the re-circulating water when mechanical draft towers are used, but increases to 0.3 to 1.0% for atmospheric towers. Blow down requirement (B) is estimated from the following equation if maximum permissible cycles of concentration (C) are known.

$$B = \frac{E + W(1 - C)}{C - 1}; \text{ Where } B, E, \text{ and } W \text{ are in liters/min.}$$

For trouble-free operation and minimum use of water quality control chemicals in the re-circulating water, the cycles of concentration are generally kept at 2.0 to 3.0 and, in no case, more than 4.0 in cooling towers such as these in Bombay. Hence, for a 100-tonnes air-conditioning plant re-circulating 1100 liters/min of water with a temperature drop of, say, 10°C through a mechanical draft tower where cycles of concentration are to be restricted to 2.0.

$$E = 2\% \times 1100 = 22 \text{ liters/min}; W = 0.2\% \times 1100 = 2.2 \text{ liters/min}$$

$$B = \frac{22 + 2.2(1 - 2)}{(2 - 1)} = 20 \text{ litres/min (approx)}$$

The total make-up water requirement thus equals 44.2 liters/min (= 22 + 2.2 + 20) or 63.4 m<sup>3</sup>/day for 24-hrs working of this 100-tonnes plant.

Similarly, if 3.0 cycles of concentration are permissible, the total requirement of make-up water reduces to 47.7m<sup>3</sup>/day for 100-tonnes plant.



**This page  
intentionally left  
blank**

# 12 VIRTUAL WATER

## 12.1 INTRODUCTION

**Virtual Water:** This is a concept that was developed by Prof. Tony Allan, which refers to the volume of water needed to produce a commodity or service. For example, it typically takes 1,000 tonnes of water to produce one tonne of wheat. This represents the Virtual Water value of wheat. As such, it is easier and less ecologically destructive, to import one tonne of wheat than to pipe in 1,000 tonnes of water (Turton, 2000a). Virtual Water is also present in hydroelectric power and constitutes the volume of water needed to produce a given unit of hydroelectricity (Turton, 1998).

Virtual Water is a fascinating concept that is now being developed and refined for use by decision-makers at the strategic level of society. Recourse to trade in times of scarcity has been an age-old mechanism by which society has managed to cope with acute water deficit. This mechanism is now being considered as a component of a longer-term strategy. As such, **the trade in Virtual Water has shown itself elsewhere to be economically viable, and politically silent.** A fine line exists between viable trade in Virtual Water and food aid. As such a balance needs to be struck between economic development and foreign trade. Similarly, post-colonial dependency is also politically risky. Therefore, a balance needs to be struck between a policy of national self-sufficiency and food security. All policies are doomed to fail however, if the underlying driver of water deficit is ignored. As such, water deficit is not really the problem. It is merely the manifestation of a greater and more complex problem — uncontrolled population growth.

## 12.2 THE CONCEPTS OF WATER FOOTPRINT AND VIRTUAL WATER

### **Water Footprint**

Water footprint is quite simply the volume of water used. At the individual level, this is expressed in litres. But at the national level, this becomes complex — the water footprint of a nation is equal to the use of domestic water resources, minus the virtual water export flows, plus the virtual water import flows.

The total ‘water footprint’ of a nation is a useful indicator of a nation’s call on the global water resources. The water footprint of a nation is related to dietary habits of people. High

consumption of meat brings along a large water footprint. Also the more food originates from irrigated land, the larger is the water footprint. Finally, nations in warm climate zones have relatively high water consumption for their domestic food production resulting in a larger water footprint. At an individual level, it is useful to show the footprint as a function of food diet and consumption patterns.

1 cup of coffee needs 140 litres of water.

1 litre of milk needs 800 litres of water.

1 kg of wheat needs 1100 litres of water.

1 kg of rice needs 2300 litres of water.

1 kg maize needs 900 litres of water.

- The production of one kilogram of beef requires 22 thousand litres of water.
- To produce one cup of coffee, we need 140 litres of water.
- The water footprint of China is about 775 cubic meter per year per capita. Only about 3% of the Chinese water footprint falls outside China.
- Japan with a footprint of 1100 cubic meter per year per capita, has about 60% of its total water footprint outside the borders of the country.
- The USA water footprint is 2600 cubic meter per year per capita.

*(Source: UNESCO-IHE - Water Footprint)*

### **Virtual Water**

Virtual water is the amount of water that is embedded in food or other products needed for its production. Trade in virtual water allows water scarce countries to import high water consuming products while exporting low water consuming products and in this way making water available for other purposes [World Water Council].

Ten litres of orange juice needs a litre of diesel fuel for processing and transport, and 220 litres of water for irrigation and washing the fruit. The water may be a renewable resource, but the fuel is not only irreplaceable but is a pollutant, too.

For example, the virtual water content (in m<sup>3</sup>/tonne) for potatoes is 160. Others examples — maize = 450; milk = 900; wheat = 1200; soyabean = 2300; rice = 2700; poultry = 2800; eggs = 4700; cheese = 5300; pork = 5900; and beef = 16000.

Showing people the ‘virtual water’ content of various consumption goods will increase the water awareness of people.

### **12.3 DEFINITIONS**

**Virtual water content:** The virtual water content of a product is the volume of water used to produce the product, measured at the place where the product was actually produced. The virtual water content of a product can also be defined as the volume of water that would have been required to produce the product in the place where the product is consumed. The adjective ‘virtual’ refers to the fact that most of the water used to produce a product is in the end not

contained in the product. The real water content of products is generally negligible if compared to the virtual water content.

**Virtual water export:** The virtual water export of a country or region is the volume of virtual water associated with the export of goods or services from the country or region. It is the total volume of water required to produce the products for export.

**Virtual water import:** The virtual water import of a country or region is the volume of virtual water associated with the import of goods or services into the country or region. It is the total volume of water required (in the export countries) to produce the products for import. Viewed from the perspective of the importing country, this water can be seen as an additional source of water that comes on top of the domestically available water resources.

**Virtual water flow:** The virtual water flow between two nations or regions is the volume of virtual water that is being transferred from one place to another as a result of product trade.

**Virtual water balance:** The virtual water balance of a country over a certain time period is defined as the net import of virtual water over this period, which is equal to the gross import of virtual water minus the gross export. A positive virtual water balance implies net inflow of virtual water to the country from other countries. A negative balance means net outflow of virtual water.

**National water saving:** A nation can save its domestic water resources by importing a water-intensive product rather than produce it domestically.

**Global water saving:** International trade can save water globally if a water-intensive commodity is traded from an area where it is produced with high water productivity (resulting in products with low virtual water content) to an area with lower water productivity.

**Coping strategy:** A coping strategy is the output of the decision-making elite, usually in the form of some coherent policy or set of strategies such as water demand management, that seeks to manage the water scarcity in some form or another (Turton & Ohlsson, 1999). A coping strategy is the synthesis of a logical series of options that decision-makers consider, thereby converting those options into a clearly defined policy choice with which to confront the problems of rising levels of water scarcity in a given state or regional setting. A coping strategy contains a logic of its own that is based on political rationality, which in turn may not coincide with an outsider's perception of rationality.

**Problemshed:** This is a conceptual unit in which the remedy for a problem can be found. In other words, conventional wisdom would have us believe that watersheds are the unit of management, but it is also at this level that water deficit exists.

**Sectoral water efficiency:** The Sectoral Water Efficiency (SWE) is the ratio of water consumed within a given economic sector (expressed as a percentage of total national water consumption) in relation to contribution of the same economic sector to overall GDP (expressed as a percentage of total GDP) (Sectoral Water Efficiency = Sectoral Water Consumption as % : Sectoral Contribution to GDP as %) (Turton, 1998:7).

**Water deficit:** This refers to the prevailing condition that exists when the consumption of freshwater within a given social entity exceeds the level of sustainable supply (Turton, 2000b).

**Water scarcity:** This is the condition that exists when the demographically induced demand for water exceeds the prevailing level of local supply, meaning that supply-sided augmentation becomes necessary (Turton & Meissner, 2000).

#### 12.4 UNDERLYING ASSUMPTIONS

In order to fully understand the relative advantages and disadvantages of a Virtual Water-based coping strategy, it is necessary to first focus attention on some of the key underlying assumptions of which five are strategically significant.

1. The notion of a nation-state with geographic integrity and decision-making sovereignty is taken as a given. This implies that within each nation-state there is a group of decision-makers that have the responsibility of maximizing national security by increasing the likelihood of economic prosperity and social stability.
2. The watershed or river basin is the unit of management.
3. River basins are natural creations, having taken millions of years to develop. Nation-states, it can be argued, are largely unnatural in the sense that human beings onto a natural world have imposed them.
4. Water scarcity is a localized phenomenon, manifesting largely within a given watershed or river basin.
5. It is necessary to understand that national political economies are subordinate to regional political economies.

#### 12.5 POPULATION - FOOD - TRADE NEXUS

Before one can fully understand the implications of Virtual Water, one needs first to understand the role of water in society within the context of a developing state or region. The so-called population-food-trade nexus really lies at the very heart of the subject. In this regard, there are five strategically important issues that need to be understood.

1. Population growth is the fundamental driver of water scarcity. In fact, water scarcity is not the problem — it is merely a manifestation of a far more fundamental problem — rapid and unchecked population growth.
2. This population-related sanctioned discourse has two distinct manifestations that need to be understood. For reasons of simplicity, let us call these two manifestations the visible and invisible fractions of water consumption patterns. The visible water fraction is easy to understand because it is the one that is most readily perceived by the layperson. This can best be illustrated by means of a graph showing the direct correlation between population growth and water demand in a given spatial entity. Figure 12.1 shows the direct correlation between population growth and water demand for the city of Windhoek. From this, it is clear that a close correlation exists between population growths.

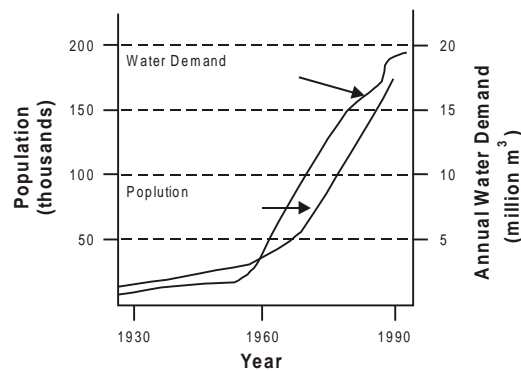

**Fig. 12.1** Growth of Windhoek's population and water demand (after Jacobson et al., 1995). This can be thought of as being the visible fraction of water demand.

This is typical of the problem being faced by urban water supply schemes so the literature is rich with examples. While this is clearly an important aspect of water resource management, it does not tell the full story and as such can be misleading to strategic decision-makers. This is where the invisible water fraction becomes relevant. Ohlsson (1999) provides an insight into the problem by showing a breakdown of water needs for one human being expressed in liters of water per day. In terms of this analysis, one human being can survive on 2-5 liters per day for drinking purposes; between 25 and 100 liters per day are needed for domestic use such as sanitation services, washing of clothes and cooking utensils, etc; and between 1,000 and 6,000 liters per day are used for food and biomass production. From this it is evident that the volumes of water that a local authority would need to supply — the so-called visible fraction of water consumption — is in the order of 27-105 liters per person per day. This falls into absolute insignificance when compared to the invisible fraction of water consumption for the same person, which according to Ohlsson (1999) ranges between 1,000 and 6,000 liters per day (depending on where that person lives and what type of diet is taken as being normal). Stated differently, at the lowest end of the scale, the invisible water fraction (for food) is 37 times greater than the visible fraction. At the highest end of the same scale, the invisible fraction of water in the form of food is a staggering 57 times greater than the visible fraction. This nuance is largely ignored in the literature.

This can be understood by means of a simpler illustration. Let us take the basic water requirement (BWR) as 50 liters per person per day. Let us then accept that a healthy diet consists of 3000 calories of food per person per day. We know that on average, it takes around one liter of water to produce one calorie of food. This translates to 3000 liters of water per person per day for the invisible fraction of water for food production, which is a staggering 60 times greater than the visible fraction of water consumption. Therefore in order to ensure an adequate supply of food and water for one person for a year, a whopping 1113 tonnes of water is needed of which a mere  $\frac{1}{60}$ th (18 tonnes) is related to the visible fraction.

3. We need to take yet another fundamental fact into consideration. This is related to the Sectoral Water Efficiency (SWE) of agriculture versus industry. Ohlsson (1999) states that a reasonably acceptable global benchmark figure for agricultural water consumption is 65-70% of the total water abstractions in a given country. This will obviously vary from country to country, largely as the result of agricultural dependence. In developing countries this can be higher. An acceptable international benchmark for industrial water abstraction is in the order of 20-25% of the total water abstraction in any given country. Of this a small fraction (9%) is consumptive use, with the rest being recaptured via treatment and recycling technologies and therefore made available for other economic purposes or activities. The world benchmark for household water abstraction is only 5-10% of the total water abstraction in any given country. So, in terms of pure abstraction alone, agriculture is by far the largest user of water in any given economy.

Thus, in general terms, the agricultural SWE is low whereas the industrial SWE tends to be high. In fact water that is diverted away from agricultural use into the industrial and urban domestic sectors, can produce 70 times more economic value for given volume of water (Ohlsson, 1999).

**Table 12.1 Selected SWE statistics for four SADC member states during 1995 (after Turton 1998)**

Botswana	Agricultural Industrial	48:5 20:46	High Medium
Namibia	Agricultural Industrial	68:14 3:26	Medium Medium
South Africa	Agricultural Industrial	72:6 11:30	Medium Medium
Zimbabwe	Agricultural Industrial	79:14 7:30	Low Medium

4. Having noted that an industrialized economy tends to be more water efficient, another critical aspect also becomes relevant to this guide. This different SWE characteristic allows the notion of economic gearing to be brought to bear on the problem of water deficit. This in turn implies a better water use pattern, and in particular, the ability to generate foreign currency with which to finance Virtual Water imports.
5. The latter issue of social stability gives us a clue as to the existence at strategic levels of yet another critically important aspect, namely the social ability to adapt to changing levels of water deficit.

## 12.6 STRATEGIC ISSUES

There are seven key issues that need to be understood.

1. By broadening the water management paradigm from the watershed or river basin level of analysis, to the problemshed level of analysis, an increased range of options become

available to the strategic-level decision-maker. It is this fact alone, that has mitigated against the confidently prophesied water wars in the Middle East (Allan, 1998).

2. By reaching into the problemshed for a solution, vast quantities of Virtual Water become available at reasonable (usually subsidized) prices, with the added advantage of being environmentally sustainable. The current global grain surplus sees Virtual Water that has been harvested from the soil profiles of water abundant countries, often at highly subsidized rates, becoming a viable means of balancing local-level water deficits. During times of drought, countries often resort to importing grain or foodstuffs. This time-tested remedy has always been available to governments in water stressed regions. The only difference between this normal coping strategy, and a Virtual Water-based solution, is the fact that the former is a once off act, whereas the latter is a deliberate policy choice.
3. There is a definite conceptual difference between a country that uses Virtual Water as a rational coping strategy and a country that relies on food aid for survival. Japan, for example, does not grow all of its own food, but Japan is certainly not aid-dependent. Botswana and South Africa are shifting away from a policy of national-self-sufficiency in food to one of food security instead. The difference between a country that has a rational coping strategy based on Virtual Water and an aid-dependent country is therefore the ability to pay.
4. A rational coping strategy that is based on the merits of virtual water implies a fundamental re-think of the policy of national self-sufficiency in foodstuffs. In fact, a Virtual Water paradigm is based on a policy of food security instead, with a strong and diversified economy with which Virtual Water imports can be paid for in a sustainable manner. This does not imply that a new form of post-colonial political or economic dependence is being accepted. It does imply however, that a balance needs to be struck between the relative merits (and demerits) of national self-sufficiency versus food security. For example, South Africa as a diversified political economy was forced to adopt a national self-sufficiency policy as the result of apartheid-induced sanctions. This implied massive mobilization of water for irrigation purposes, to the extent that environmental sustainability became a key issue. Virtual water is therefore environmentally friendly, and as such ought to be supported by environmental NGOs and special interest groups as a fundamental component of sustainable development in water deficit regions of the world.
5. Virtual water is politically silent (Allan, 2000). It is therefore never expected to become front-page news in any country that uses it as a coping strategy. In fact, research shows that where it is used, the political decision-makers concerned can keep up the necessary lie that water deficit is not a problem for economic growth and social stability.
6. Virtual water is not a universal panacea of all water-related problems however. This fact needs to be appreciated as well. While water deficit can be balanced at the strategic level of a given country, it will not necessarily relate to food security at the household level of society.



7. Virtual water can become a powerful tool for balancing the water budget at a regional level. This is particularly useful within the context of SADC, where development is spatially uneven and where water distribution patterns do not match economic development patterns. As such, by considering a virtual water paradigm as a fundamental driver of intra-regional trade and development, it can fast-track agricultural and economic development in a more equitable and sustainable way.

## 12.7 THE ECONOMICS OF WATER USE

Water should be considered as an economic good. The problems of water scarcity, water excess and deterioration of water quality would be solved if the resource 'water' were properly treated as an economic well. The logic is clear: clean fresh water is a scarce good and thus should be treated economically. There is an urgent need to develop appropriate concepts and tools to do so.

In dealing with the available water resources in an economically efficient way, there are three different levels at which decisions can be made and improvements be achieved. The first level is the user level, where price and technology play a key role. This is the level where the 'local water use efficiency' can be increased by creating awareness, charging prices based on full marginal cost and by stimulating water-saving technology. Second, at a higher level, a choice has to be made on how to allocate the available water resources to the different sectors of economy (including public health and the environment). Water is used for the production of several 'goods' and 'services'. People allocate water to serve certain purposes, which generally implies that other, alternative purposes are not served. Choices on the allocation of water can be more or less 'efficient', depending on the value of water in its alternative uses. At this level, we speak of 'water allocation efficiency'. Water is a public good, so water allocation at the country or catchment level is principally a governmental issue. The question is here how all demands for water can best be met and where — in case of water shortage — supply should be restricted.

Beyond 'local water use efficiency' and 'water allocation efficiency' there is a level at which one could talk about 'global water use efficiency'. It is a fact that some regions of the world are waterscarce and other regions are water-abundant. It is also a fact that in some regions there is a low demand for water and in other regions a high demand. Unfortunately there is no general positive relation between water demand and availability. Until recently people have focused very much on considering how to meet demand based on the available water resources at national or river basin scale. The issue is then how to most efficiently allocate and use the available water. There is no reason to restrict the analysis to that. In a protected economy, a nation will have to achieve its development goals with its own resources. In an open economy, however, a nation can import products that are produced from resources that are scarcely available within the country and export products that are produced with resources that are abundantly available within the country. A water-scarce country can thus aim at importing products that require a lot of water in their production (water-intensive products) and exporting products or services that require less water (waterextensive products). This is called *import of virtual water* (as opposed to import of real water, which is generally too expensive) and will relieve the pressure on the nation's own water resources. For water-abundant countries an

argumentation can be made for *export of virtual water*. Import of water-intensive products by some nations and export of these products by others include what is called ‘virtual water trade’ between nations.

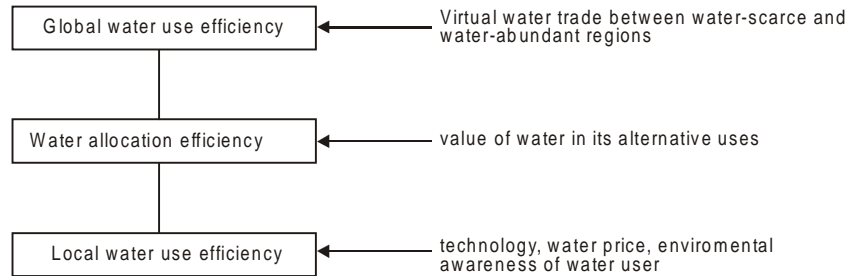

## 12.8 VIRTUAL WATER TRADE

For the production of nearly all goods water is required. The water that is used in the production process of an agricultural or industrial product is called the ‘virtual water’ contained in the product. For example, for producing a kilogram of grain, grown under rain-fed and favourable climatic conditions, we need about one to two cubic metres of water, that is 1000 to 2000 kg of water. For the same amount of grain, but growing in an arid country, where the climatic conditions are not favourable (high temperature, high evapotranspiration) we need up to 3000 to 5000 kg of water.

If one country exports a water-intensive product to another country, it exports water in virtual form. In this way some countries support other countries in their water needs. For water-scarce countries, it could be attractive to achieve water security by importing water-intensive products instead of producing all water-demanding products domestically. Reversibly, water-rich countries could profit from their abundance of water resources by producing water-intensive products for export. Trade of real water between water-rich and water-poor regions is generally impossible due to the large distances and associated costs, but trade in water-intensive products (virtual water trade) is realistic. Virtual water trade between nations and even continents could thus be used as an instrument to improve global water use efficiency and to achieve water security in water-poor regions of the world.

## 12.9 METHOD FOR CALCULATING AMOUNT OF VIRTUAL WATER

### *Calculation of Specific Water Demand Per Crop Type*

Per crop type, average specific water demand has been calculated separately for each relevant nation on the basis of FAO data on crop water requirements and crop yields:

$$SWD[n,c] = \frac{CWR[n,c]}{Cy[n,c]} \quad \dots\dots\dots(1)$$

Here, SWD denotes the specific water demand ( $\text{m}^3 \text{ tonne}^{-1}$ ) of crop  $c$  in country  $n$ , CWR the crop water requirement ( $\text{m}^3 \text{ ha}^{-1}$ ) and CY the crop yield ( $\text{tonne ha}^{-1}$ ).

The crop water requirement CWR (in  $\text{m}^3 \text{ ha}^{-1}$ ) is calculated from the accumulated crop evapotranspiration  $ET_c$  (in  $\text{mm/day}$ ) over the complete growing period. The crop evapotranspiration  $ET_c$  follows from multiplying the 'reference crop evapotranspiration'  $ET_0$  with the crop coefficient  $K_c$ :

$$ET_c = K_c \times ET_0 \quad \text{.....(2)}$$

The concept of 'reference crop evapotranspiration' was introduced by FAO to study the evaporative demand of the atmosphere independently of crop type, crop development and management practices. The only factors affecting  $ET_0$  are climatic parameters. The reference crop evapotranspiration  $ET_0$  is defined as the rate of evapotranspiration from a hypothetical reference crop with an assumed crop height of 12 cm, a fixed crop surface resistance of  $70 \text{ s m}^{-1}$  and an albedo of 0.23. This reference crop evapotranspiration closely resembles the evapotranspiration from an extensive surface of green grass cover of uniform height, actively growing, completely shading the ground and with adequate water (Smith et al., 1992). Reference crop evapotranspiration is calculated on the basis of the FAO Penman-Monteith equation (Smith et al., 1992; Allen et al., 1994a, 1994b; Allen et al., 1998):

$$ET_0 = \frac{0.408\Delta(R_n - G) + \gamma \frac{900}{T + 273} U_2 (e_a - e_d)}{\Delta + \gamma(1 + 0.34U_2)} \quad \text{.....(3)}$$

In which:

- $ET_0$  = reference crop evapotranspiration [ $\text{mm day}^{-1}$ ];
- $R_n$  = net radiation at the crop surface [ $\text{MJ m}^{-2} \text{ day}^{-1}$ ];
- $G$  = soil heat flux [ $\text{MJ m}^{-2} \text{ day}^{-1}$ ];
- $T$  = average air temperature [ $^{\circ}\text{C}$ ];
- $U_2$  = wind speed measured at 2 m height [ $\text{m s}^{-1}$ ];
- $e_a$  = saturation vapour pressure [ $\text{kPa}$ ];
- $e_d$  = actual vapour pressure [ $\text{kPa}$ ];
- $e_a - e_d$  = vapour pressure deficit [ $\text{kPa}$ ];
- $\Delta$  = slope of the vapour pressure curve [ $\text{kPa } ^{\circ}\text{C}^{-1}$ ];
- $\gamma$  = psychrometric constant [ $\text{kPa } ^{\circ}\text{C}^{-1}$ ].

The crop coefficient accounts for the actual crop canopy and aerodynamic resistance relative to the hypothetical reference crop. The crop coefficient serves as an aggregation of the physical and physiological differences between a certain crop and the reference crop.

The overall scheme for the calculation of specific water demand is drawn in Fig. 12.2 This figure also shows the next step: the calculation of the virtual water trade flows between nations.

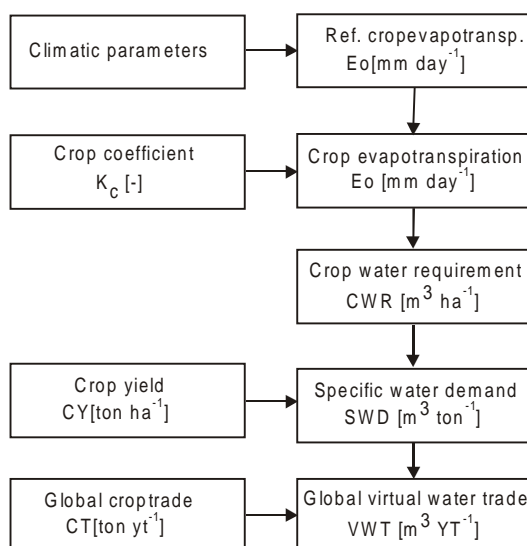

Fig. 12.2 Steps in the calculation of global virtual water trade.

### Calculation of Virtual Water Trade Flows and the National Virtual Water Trade Balance

Virtual water trade flows between nations have been calculated by multiplying international crop trade flows by their associated virtual water content. The latter depends on the specific water demand of the crop in the exporting country where the crop is produced. Virtual water trade is thus calculated as:

$$VWT[n_e, n_i, c, t] = CT[n_e, n_i, c, t] \times SWD[n_e, c] \quad \text{.....(4)}$$

in which VWT denotes the virtual water trade ( $\text{m}^3\text{yr}^{-1}$ ) from exporting country  $n_e$  to importing country  $n_i$  in year  $t$  as a result of trade in crop  $c$ . CT represents the crop trade ( $\text{ton yr}^{-1}$ ) from exporting country  $n_e$  to importing country  $n_i$  in year  $t$  for crop  $c$ . SWD represents the specific water demand ( $\text{m}^3 \text{tonne}^{-1}$ ) of crop  $c$  in the exporting country. Above equation assumes that if a certain crop is exported from a certain country, this crop is actually grown in this country (and not in another country from which the crop was just imported for further export). Although a certain error will be made in this way, it is estimated that this error will not substantially influence the overall virtual water trade balance of a country. Besides, it is practically impossible to track the sources of all exported products.

The gross virtual water import to a country  $n_i$  is the sum of all imports:

$$GVWI[n_i, t] = \sum_{n, c} VWT[n, n_i, c, t] \quad \text{.....(5)}$$

The gross virtual water export from a country  $n_e$  is the sum of all exports:

$$GVWE[n_e, t] = \sum_{n, c} VWT[n, n_e, c, t] \quad \text{.....(6)}$$

The net virtual water import of a country is equal to the gross virtual water import minus the gross virtual water export. The virtual water trade balance of country  $x$  for year  $t$  can thus be written as:

$$NVWI[x,t] = GVWI[x,t] - GVWE[x,t] \quad \dots\dots(7)$$

where NVWI stands for the net virtual water import ( $m^3yr^{-1}$ ) to the country. Net virtual water import to a country has either a positive or a negative sign. The latter indicates that there is net virtual water export from the country.

### 12.10 CALCULATION OF A NATION'S 'WATER FOOTPRINT'

The total water use within a country itself is not the right measure of a nation's actual appropriation of the global water resources. In the case of net import of virtual water import into a country, this virtual water volume should be added to the total domestic water use in order to get a picture of a nation's real call on the global water resources. Similarly, in the case of net export of virtual water from a country, this virtual water volume should be subtracted from the volume of domestic water use. The sum of domestic water use and net virtual water import can be seen as a kind of 'water footprint' of a country, on the analogy of the 'ecological footprint' of a nation. In simplified terms, the latter refers to the amount of land needed for the production of the goods and services consumed by the inhabitants of a country. Studies have shown that for some countries the ecological footprint is smaller than the area of the nation's territory, but in other cases much bigger (Wackernagel and Rees, 1996; Wackernagel et al., 1997). The latter means that apparently some nations need land outside their own territory to provide in their goods and services.

The 'water footprint' of a country (expressed as a volume of water per year) is defined as:

$$\text{Water footprint} = WU + NVWI \quad \dots(8)$$

in which WU denotes the total domestic water use ( $m^3yr^{-1}$ ) and NVWI the net virtual water import of a country ( $m^3yr^{-1}$ ). As noted earlier, the latter can have a negative sign as well.

Total domestic water use WU should ideally refer to the sum of 'blue' water use (referring to the use of ground and surface water) and 'green' water use (referring to the use of precipitation). However, data on green water use on country basis are not easily obtainable. Normally definition of water use to blue water use. It should be noted that '*net virtual water import*' as defined in eqn. 8 includes both 'blue' and 'green' water.

#### **Calculation of National Water Scarcity, Water Dependency and Water Self-sufficiency**

One would logically assume that a country with high water scarcity would seek to profit from net virtual water import. On the other hand, countries with abundant water resources could make profit by exporting water in virtual form. In order to check this hypothesis we need indices of both water scarcity and virtual water import dependency. Plotting countries on a graph with water scarcity on the x-axis and virtual water import dependency on the y-axis, would expectedly result in some positive relation.

As an index of national water scarcity, we use the ratio of total water use to water availability:

$$WS = \frac{WU}{WA} \times 100 \quad \dots\dots(9)$$

In this equation, WS denotes national water scarcity (%), WU the total water use in the country ( $m^3yr^{-1}$ ) and WA the national water availability ( $m^3yr^{-1}$ ). Defined in this way, water scarcity will generally range between zero and hundred percent, but can in exceptional cases (e.g. groundwater mining) be above hundred percent. As a measure of the national water availability WA we take the annual internal renewable water resources, that are the average freshwater resources renewably available over a year from precipitation falling within a country's borders (Gleick, 1993).

The water dependency (WD) of a nation is calculated as the ratio of the net virtual water import into a country to the total national water appropriation:

$$WD = \begin{cases} \frac{NVWI}{WU + NVWI} \times 100 & \text{if } NVWI \geq 0 \\ & \text{if } NVWI < 0 \end{cases} \quad \dots\dots(10)$$

The value of the water dependency index will vary per definition between zero and hundred percent. A value of zero means that gross virtual water import and export are in balance or that there is net virtual water export. If on the other extreme the water dependency of a nation approaches hundred percent, the nation nearly completely relies on virtual water import.

As the counterpart of the water dependency index, the water self-sufficiency index is defined as follows:

$$WSS = \begin{cases} \frac{WU}{WU + NVWI} \times 100 & \text{if } NVWI \geq 0 \\ 100 & \text{if } NVWI < 0 \end{cases} \quad \dots\dots(11)$$

The water self-sufficiency of a nation relates to the water dependency of a nation in the following simple way:

$$WSS = 1 - WD \quad \dots\dots(12)$$

The level of water self-sufficiency (WSS) denotes the national capability of supplying the water needed for the production of the domestic demand for goods and services. Self-sufficiency is hundred percent if all the water needed is available and indeed taken from within the own territory. Water self-sufficiency approaches zero if a country heavily relies on virtual water imports.

## 12.11 DATA SOURCES

Data on crop water requirements are calculated with FAO's CropWat model for Windows, which is available through the web site of FAO ([www.fao.org](http://www.fao.org)). The CropWat model uses the

FAO Penman- Monteith equation for calculating reference crop evapotranspiration. The CropWat model calculates crop water requirement of different crop types on the basis of the following assumptions:

- (1) Crops are planted under optimum soil water conditions without any effective rainfall during their life; the crop is developed under irrigation conditions.
- (2) Crop evapotranspiration under standard conditions ( $ET_c$ ), this is the evapotranspiration from disease-free, well-fertilised crops, grown in large fields with 100% coverage.
- (3) Crop coefficients are selected depending on the single crop coefficient approach, that means single cropping pattern, not dual or triple cropping pattern.

### **Climatic Data**

The climatic data needed as input to CropWat is taken from FAO's climatic database ClimWat, which is also available through FAO's web site. The ClimWat database contains climatic data for more than hundred countries. For many countries climatic data are available for different climatic stations.

### **Crop Parameters**

In the crop directory of the CropWat package sets of crop parameters are available for 24 different crops. The crop parameters used as input data to CropWat are: the crop coefficients in different crop development stages (initial, middle and late stage), the length of each crop in each development stage, the root depth, and the planting date. For the 14 crops where crop parameters are not available in the CropWat package, crop parameters have been based on Allen et al. (1998).

### **Crop Yields**

Data on crop yields is taken from the FAOSTAT database, again available through FAO's website.

**Table 12.2. Availability of crop parameters**

<i>Crops for which crop parameters have been taken from FAOs CropWat package</i>			<i>Crops for which crop from parameters have been taken Allen et al. (1998)</i>	
Banana	Maize	Sugar beet	Artichoke	Onion dry
Barley	Mango	Sugarcane	Carrots	Peas
Bean dry	Millet	Sunflower	Cauliflower	Rice
Bean green	Oil palm fruit	Tobacco	Citrus	Safflower
Cabbage	Pepper	Tomato	Cucumber	Spinach
Cotton seeds	Potato	Vegetable	Lettuce	Sweet potato
Grape	Sorghum	Watermelon	Oats	
Groundnut	Soyabean	Wheat	Onion green	

## 12.12 SPECIFIC WATER DEMAND PER CROP TYPE PER COUNTRY

The calculated crop water requirements for different crops in different countries are shown in Appendix I. The crop water requirements as calculated here refer to the evapotranspiration under optimal growth conditions. This means that the calculated values are overestimates, because in reality there are often water shortage conditions. On the other hand, the calculated values can also be seen as conservative, because they exclude inevitable losses (e.g. during transport and application of water) and required losses such as drainage. The calculated crop water requirements differ considerably over countries, which is mainly due to the differences in climatic conditions.

## 12.13 GLOBAL TRADE IN VIRTUAL WATER

### *International Trade in Virtual Water*

The calculation results show that the global volume of crop-related virtual water trade between nations was 695 Gm<sup>3</sup>/yr in average over the period 1995-1999. For comparison: the global water withdrawal for agriculture (water use for irrigation) was about 2500 Gm<sup>3</sup>/yr in 1995 and 2600 Gm<sup>3</sup>/yr in 2000 (Shiklomanov, 1997,). Taking into account the use of rainwater by crops as well, the total water use by crops in the world has been estimated at 5400 Gm<sup>3</sup>/yr (Rockström and Gordon, 2001,). This means that 13% of the water used for crop production in the world is not used for domestic consumption but for export (in virtual form). This is the global percentage; the situation strongly varies between countries.

Considering the period 1995-1999, the top-5 list of countries with net virtual water export is: 1st United States, 2nd Canada, 3rd Thailand, 4th Argentina, and 5th India. The top-5 list of countries in terms of net virtual water import for the same period is: 1st. Sri Lanka, 2nd Japan, 3rd Netherlands, 4th Republic of Korea, and 5th China. Top-30 lists are given in Table 12.3. The ranking lists do not considerably change if we look into particular years within the five-year period 1995-1999.

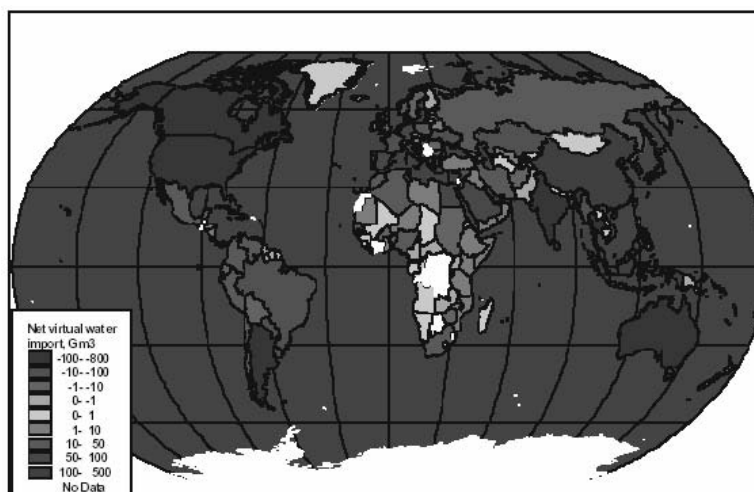

Fig. 12.3 National virtual water trade balances over the period 1995-1999



Green coloured countries have net virtual water export. Red coloured countries have net virtual water import.

National virtual water trade balances over the period 1995-1999 are shown in the coloured world map of Fig. 12.3. Countries with net virtual water export are green and countries with net virtual water import are red.

Some countries have net export of virtual water over the period 1995-1999, but net import of virtual water in one or more particular years in this period (Table 12.4). There are also countries that show the reverse (Table 12.5).

**Table 12.3. Top-30 countries of virtual water export and top-30 countries of virtual water import (over 1995-1999).**

Country	Net Export Volume (10 <sup>9</sup> m <sup>3</sup> )		Country	Net Import Volume (10 <sup>9</sup> m <sup>3</sup> )
United States	758.3	1	Sri Lanka	428.5
Canada	272.3	2	Japan	297.4
Thailand	233.3	3	Netherlands	147.7
Argentina	226.3	4	Korea Rep.	112.6
India	161.1	5	China	101.9
Australia	145.6	6	Indonesia	101.7
Vietnam	90.2	7	Spain	82.5
France	88.4	8	Egypt	80.2
Guatemala	71.7	9	Germany	67.9
Brazil	45.0	10	Italy	64.3
Paraguay	42.1	11	Belgium	59.6
Kazakhstan	39.2	12	Saudi Arabia	54.4
Ukraine	31.8	13	Malaysia	51.3
Syria	21.5	14	Algeria	49.0
Hungary	19.8	15	Mexico	44.9
Myanmar	17.4	16	Taiwan	35.2
Uruguay	12.1	17	Colombia	33.4
Greece	9.8	18	Portugal	31.1
Dominican Republic	9.7	19	Iran	29.1
Romania	9.1	20	Bangladesh	28.7
Sudan	5.8	21	Morocco	27.7
Bolivia	5.3	22	Peru	27.1
Saint Lucia	5.2	23	Venezuela	24.6
United Kingdom	4.8	24	Nigeria	24.0
Burkina Faso	4.5	25	Israel	23.0
Sweden	4.2	26	Jordan	22.4
Malawi	3.8	27	South Africa	21.8
Dominica	3.1	28	Tunisia	19.3
Benin	3.0	29	Poland	18.8
Slovakia	3.0	30	Singapore	16.9

**Table 12.4. Countries with net export of virtual water in the period 1995-1999 that have however net import in particular years. A 'minus' indicates a negative virtual water trade balance (i.e. net export of virtual water). A 'plus' indicates a positive virtual water trade balance (i.e. net import of virtual water)**

Country	1995	1996	1997	1998	1999
Brazil	-	+	-	-	-
Syria	-	-	-	-	+
Greece	-	-	-	+	-
Sudan	-	+	+	+	-
United Kingdom	+	+	-	+	+
Burkina Faso	-	+	+	-	-
Benin	+	-	-	-	-
Slovakia	-	-	+	-	-
Ecuador	-	-	-	+	-
Bulgaria	-	+	+	-	-
Cuba	+	-	-	+	-
Finland	-	-	-	-	+
Yugoslavia	-	-	+	-	-
Uganda	-	-	+	+	+
Papua N. Guinea	-	-	+	-	+
Bahamas	+	-	-	-	-
Montserrat	-	-	-	-	+
Tajikistan	+	-	-	-	-
Cameroon	-	-	+	+	-
Martinique	-	+	+	+	+
Pakistan	-	-	+	-	+
Solomon Islands	-	+	-	+	+
Central Africa	-	+	-	+	-
Samoa	-	-	-	+	-
Wallis Island	-	+	+	+	+

**Table 12.5 Countries with net import of virtual water in the period 1995-1999 that have however net export in particular years. A 'minus' indicates a negative virtual water trade balance (i.e. net export of virtual water). A 'plus' indicates a positive virtual water trade balance (i.e. net import of virtual water)**

Country	1995	1996	1997	1998	1999
St. Kitts & Nevis	-	+	-	+	+
Guinea Bissau	+	+	-	-	+
Burundi	+	+	-	+	+
Tonga	+	+	-	+	+
Mongolia	-	+	+	+	+
Nepal	+	+	+	-	+
Kyrgyzstan	+	+	-	-	-
Macedonia	-	+	+	+	+
Lithuania	+	+	+	-	-
Bermuda	+	+	+	-	-
Bahrain	+	+	+	-	+
Gambia	+	+	+	-	+
Bosnia	+	-	+	+	+
Madagascar	+	-	-	+	+
George	+	+	+	+	-
Croatia	-	-	+	+	+
Nicaragua	+	+	-	+	+
Uzbekistan	+	+	+	+	-
Czech Republic	-	+	+	+	-
Philippines	-	-	+	+	+
Russian Fed.	-	-	+	-	+
Mexico	+	+	-	+	+

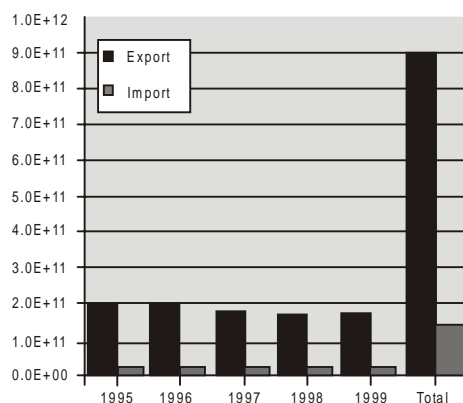

**Fig. 12.4** Gross virtual water import into and export from the United States in the period 1995-1999 ( $m^3 yr^{-1}$ ).

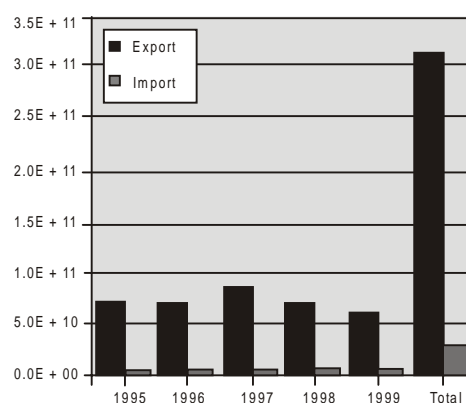

**Fig. 12.5** Gross virtual water import into and export from Canada in the period 1995-1999 ( $m^3 yr^{-1}$ ).

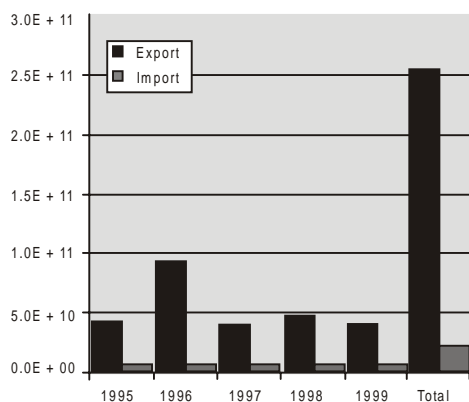

**Fig. 12.6** Gross virtual water import into and export from Thailand in the period 1995-1999 ( $m^3 yr^{-1}$ ).

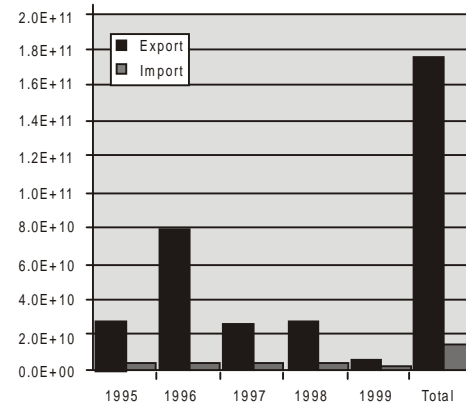

**Fig. 12.7** Gross virtual water import into and export from India in the period 1995-1999 ( $m^3 yr^{-1}$ ).

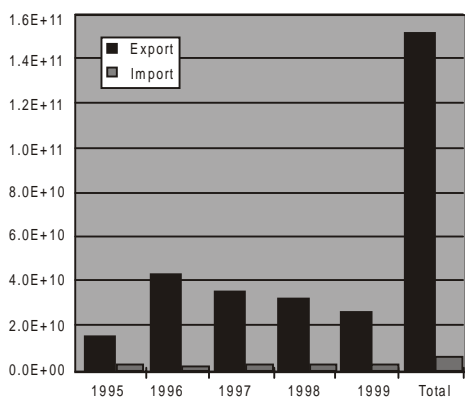

**Fig. 12.8** Gross virtual water import into and export from Australia in the period 1995-1999 ( $m^3 yr^{-1}$ ).

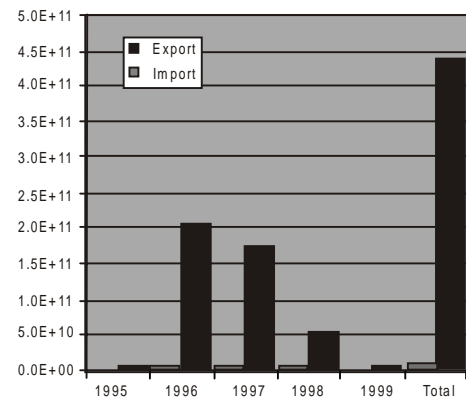

**Fig. 12.9** Gross virtual water import into and export from Sri Lanka in the period 1995-1999 ( $m^3 yr^{-1}$ ).

### International Virtual Water Trade by Product

The total volume of crop-related virtual water trade between nations in the period 1995-1999 can be for 30% which can explain by trade in wheat. Next come soyabeans and rice, which account respectively for 17% and 15% of global crop-related virtual water trade.

### Inter-regional Trade in Virtual Water

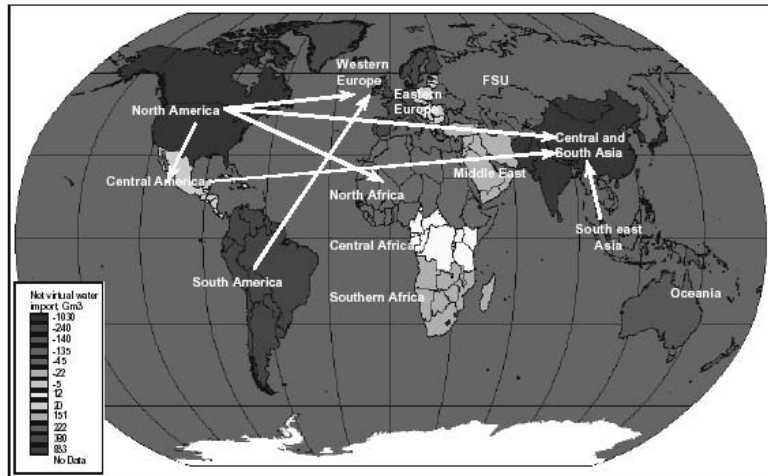

Fig. 12.10 Virtual water trade balances of 13 world regions over the period 1995-1999. Green coloured regions have net virtual water export; red coloured regions have net virtual water import. The arrows show the largest net virtual water flows between regions (>100 Gm<sup>3</sup>).

### Virtual Water Trade Balance Per World Region

The virtual water trade balances of the 13 world regions are shown in Fig. 12.11a and 12.11b. The former shows the gross import and export of virtual water for each region. The latter shows the difference between the two, the net import, which is positive in some cases and negative in others.

North America is by far the biggest virtual water exporter in the world, while Central and South Asia is by far the biggest virtual water importer.

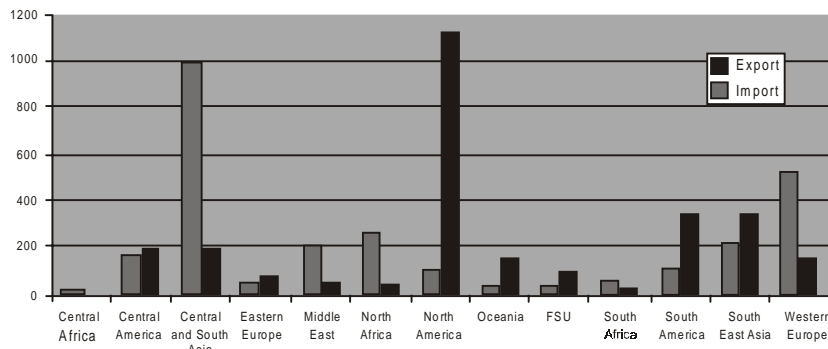
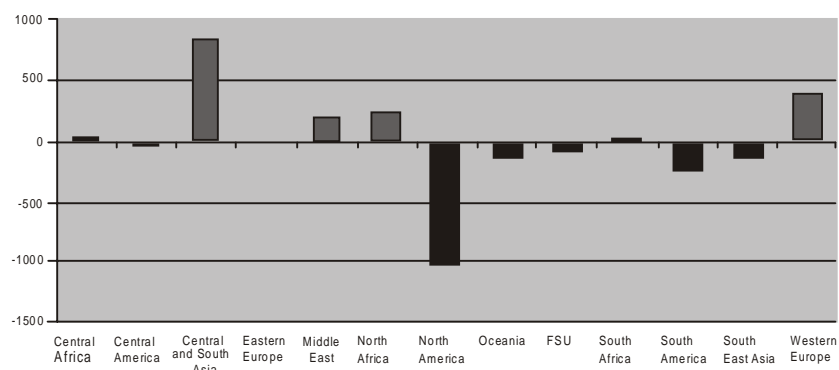

Fig. 12.11a Gross virtual water import and export per region in the period 1995-1999 (Gm<sup>3</sup>).



**Fig. 12.11b** Net virtual water import per region in the period 1995-1999 (Gm<sup>3</sup>).

### CONCLUDING REMARKS

Here virtual water trade related to crop trade between nations mentioned. Also other goods contain virtual water, for instance meat, dairy products, cotton, paper, etc. In order to get a complete picture of the global virtual water trade flows, also other products than crops have to be taken into account. For instance, the virtual water trade balance of the Netherlands drawn in the current study suggests that this country has an incredibly high net import of virtual water, due to the large import of feed for the Dutch bio-industry. The balance will look quite differently if we would take into account the export of virtual water that relates to the export of meat from the Netherlands.

Knowing the national virtual water trade balance is essential for developing a rational national policy with respect to virtual water trade. But for some large countries it might be as relevant to know the internal trade of virtual water within the country. China for instance, relatively dry in the north and relatively wet in the south, domestic virtual water trade is a relevant issue.

*Appendix : I Crop water requirements (m<sup>3</sup>/ha) (source: crop wat model)*

Country	Banana	Barley	Bean Green	Ground Nut	Maize	Potato	Sugar Cane	Vegetables	Onion Dry	Rice	Wheat	Cotton Seed
Afghanistan	6800	3770	3540	3890	3340	2980	12740	4040	—	5900	4350	7410
Australia	8970	4030	2670	5930	4380	5790	18520	1190	6620	8600	4730	8710
Bangladesh	7050	3520	3260	4600	3350	3420	13460	3300	—	8200	4260	8300
Brazil	7730	4220	2250	4830	3480	4400	14250	3180	6630	7800	3320	6680
Canada	7120	3560	2200	3180	3170	3130	12830	2950	6920	6200	3740	4872
China	6180	4100	4120	4960	3600	4070	9870	2920	6680	6800	4040	6780
Germany	7120	3560	2200	3180	3170	3130	12830	2460	6590	6900	3740	3880
India	8610	3780	5190	6930	4720	4820	20300	5460	6400	9880	6910	9190
Indonesia	8640	4180	3020	5010	4850	6170	16480	2680	5170	9300	3950	7080
Israel	13070	8800	—	5980	6350	4780	24710	4400	6160	12000	6100	11920
Italy	6630	4850	3530	5370	2460	5500	18920	4070	6710	6400	6540	8752
Japan	6400	3650	2980	4620	3160	2410	10100	2810	6190	7600	3760	6510
Korea	6600	2460	2980	3370	2190	2300	10600	3790	6820	6570	3820	7020
New Zealand	6570	3640	2120	3540	3250	6290	12850	2430	5740	—	3030	6110
Singapore	7810	3560	3180	4950	4250	4480	15020	3050	6820	—	4150	8930
South Africa	8970	4030	2670	5930	4380	4680	18520	4490	—	—	4730	8710
Sri Lanka	8970	5590	4570	6870	6640	6930	15780	5140	—	—	8730	—
U K	7120	3580	2200	3180	3170	3290	12830	2450	3780	5900	3740	—
U S A	6570	3640	2120	3180	3170	3290	12830	2450	4830	8600	3740	6210

# 13

## CREATION OF SWEET WATER

### 13.1 ARTIFICIAL RAIN

There is a river in the sky a complex, swirling, tumultuous river of air and water. Sometimes we cannot see the water, when it is in the form of vapor. At other times, airborne droplets of water gather in clouds, which, of course, can be seen. We should not assume that clouds contain water and the surrounding air does not, because the surrounding air carries vapor, which often flows into the cloud. And, also, clouds dissolve into vapor and fade away. But the clouds we see with our eyes contain water brought along a step in the process of becoming rain. With clouds we can have rain. Without clouds we cannot. But with clouds we do not necessarily have rain. The droplets of water often fail to take the further step of becoming raindrops, accretions of water become heavy enough to fall to the ground.

This exasperates the farmer — when lush clouds, apparently containing a great deal of moisture, float over his dry fields and fail to precipitate out even one small part of the moisture carried by and flowing into these clouds. Cloud census studies have shown that seasons with considerable cloud cover can also be dry seasons.

Why? Can we coerce the droplets into becoming drops heavy enough to fall onto the ground? Can we haul down needed moisture from sky?

A FEW YEARS AGO many of us thought we had been theorized that minute particles of dust, present throughout the atmosphere, were a necessary ingredient of rain, something for the droplets to cluster on and grow. In 1946, Dr. Vincent J. Schaefer, of the General Electric Co., sprinkled particles of dry ice from an airplane and produced precipitation. A little later Dr. Bernard Vonnegut of General Electric ran onto silver iodide as the ideal particle or crystal. A few experiments produced seemingly awe-inspiring results.

And so, “scientific rainmaking” came into being. The scientific basis of it was “artificial nucleation” — that is, the supplying of artificial nuclei or particles to clouds thought to lack sufficient natural nuclei.

A comment on terminology should be inserted at this point. The word “rainmaking” seems to imply the creation of water, whereas so-called rainmakers cannot produce water that does not already exist in the air. Perhaps “rain increasing” should be used. Further, the



phrase “Weather control” implies a management of the elements beyond present conception. Perhaps “weather modification” states more accurately what we can now visualize. The terms “rainmaking” and “weather control”, however, have become common and are more easily recognized.

Artificial nucleation is tied in with the ice crystal theory. According to the theory, natural ice crystal formation occurs at quite low temperatures ( $-40^{\circ}$  F). Presumably the crystals grow by attracting other moisture particles until they become heavy enough to fall out of the clouds as snow, which melts on the way down and becomes rain.

Dropping dry ice (carbon dioxide) on clouds cools areas of those clouds and starts the process of crystal formation. The effect can be substantial if the clouds are near the temperature at which ice crystals form naturally.

Supplying nuclei to clouds does not cool them, but with nuclei the ice crystal formation occurs at higher temperatures — that is, below freezing but closer to the freezing level. Some natural nuclei or dust particles start the process at temperatures between  $-40^{\circ}$  and  $5^{\circ}$ . But crystals of silver iodide (artificial nuclei) start it between  $5^{\circ}$  and  $25^{\circ}$ .

Therefore, silver iodide not only can start rainfall in clouds too warm for natural rainfall production but also can increase rainfall in clouds already producing small amounts by nucleating the warmer lower sections.

Another method of producing rainfall is of interest, although not of commercial importance. In warm regions, non-freezing clouds release rain, obviously by some other process than the formation of ice crystals.

It is commonly believed that precipitation results when larger than normal water droplets fall relative to other droplets, collecting enough smaller ones to grow to raindrop size large enough to fall out of the cloud. The answer lies in providing the larger droplets.

Such clouds, found in the Southern States and farther north in the summer, have been successfully seeded by water sprayed from airplanes.

But airplanes cost money to operate and flying them into storm clouds can be dangerous. The large commercial “cloud – seeders” therefore do not use dry ice or water but rely on silver iodide, which can be released from ground generators. The minute crystals drift away from the generators and presumably get sucked into the updrafts of storm clouds.

Experts suggest that rainmaking is a pretty big business, even with its uncertainties.

The study indicates that the rainmakers really have modified the weather significantly—an assumption that a majority of scientists familiar with the subject do not go along with wholeheartedly. Most of them seem to agree that nucleating agents can modify weather in certain circumstances. Some think these circumstances occur frequently enough so that man can change the whole pattern of water distribution, with a tremendous impact on the economy. Others are skeptical of large-scale effects. Most of them say: “A lot more has to be learned about the rainmaking process before we can tell”.

The rainmakers answer the argument by saying that nature is an inefficient rainmaker, with only about 1 percent of a cloud's moisture falling to the ground in an ordinary storm. By supplying more nuclei they may increase this efficiency up to 2 percent. Such amounts are insignificant, they say, and the vast streams of moisture floating in the sky will replenish the clouds almost immediately.

Whatever the merits of this, rainmaking, viewed on a grander scale, may indeed increase substantially the amount of mineral-free water available for man's use.

FOR ONE THING, it seems perfectly obvious that many airborne streams of moisture escape the land and give much of their water back to the seas. Rainmaking might make it possible for us to take better advantage of the rain potential of these airborne streams before they get away. For another thing, it has been suggested that precipitating moisture out of clouds at earlier stages of storm development might speed up the hydrologic cycle and establish a new rainfall regime. This would mean more use and reuse of air-borne moisture.

But even if rainmaking could not increase the net amount of moisture on the ground, it might yet affect the distribution of this moisture in such a way as to produce tremendous economic benefits.

DOES IT REALLY WORK? That is the question farmers ask. Scientists reply that it does in certain circumstances.

Seeding with dry ice and water admittedly has modified clouds and has produced precipitation. Silver iodide can do the same.

But scientists disagree as to whether the more economic method of seeding clouds by means of ground generators produced, or can produce, the substantial increases in rain and snowfall claimed by the private "cloud-seeders".

The problem of evaluation is inherent in the ground-generator method. Seeding with dry ice or water, the operator can usually turn around and see the results. The seeded clouds often change form and precipitation falls before his eyes. But when he releases silver iodide from a generator he cannot see the material. Does the generator produce the right-sized crystals? Do they get into the storm clouds in the right quantities at the right altitude? Does the silver iodide retain its effectiveness or does it decay because of temperature, pressure, or exposure to ultraviolet rays. There can be many a slip between the cup and the lip.

The fact that he seeds during storm situations, usually when at least some rain fall naturally, makes visual observation impossible in most cases and makes measurement of any manmade increase extremely complicated.

And so, instead of seeing the cause and effect, he has to guess. And he has to attempt a measurement of the manmade increase by means of statistical evaluation. He has to compare the "target area" rainfall with rainfall of past years or, more commonly, with rainfall received in adjacent areas.

Statistical analyses – usually provided by the cloud-seeder himself and imperfectly understood by the layman – can often show spectacular and convincing results. But sometimes figures the statistical people can bury good results in a pile of figures. Thus, there is controversy.

The analyses themselves get complicated, but the problem of analysis can be stated quite simply.

When the target area gets more rain than outside areas, say three control areas labeled “A” “B” and “C,” the cloud-seeder usually satisfies his clients. Yet the center of a storm may have passed over the target area to produce the result naturally and the cloud-seeder may have done nothing.

When the target area gets more rain than A and B, but less than C, the clients may nurse a small doubt or two. And when the target area gets less than A, B, and C — then they become skeptics. Yet in both cases the cloud-seeder may have increased rainfall on the target area over the amount, which would have fallen naturally.

Rainfall results in the target areas usually fall within the realm of historical variation. We can always suspect therefore, that increases are only accidental. If we only knew how much rain would have fallen naturally, we can never know and we have to satisfy ourselves with a statistical substitute.

A study of an entire river basin in the United States, based on physical assumptions considerably more modest than some cloud-seeders have asserted, showed a benefit — cost ratio of 20 to 1. Obviously experiments in certain areas—possibly mountain areas where air movements showed into the clouds and where temperatures should be more favorable—these should show a higher benefit — cost ratio. Experiments in some areas should prove to be more nearly marginal.

Experiments in the United States have attracted a great deal of interest in foreign countries. At least 26 countries, on every continent except Antarctica, have carried out experiments in recent years.

Farmers in South Africa have used rockets to disperse silver iodide at high altitudes, the purpose being to reduce hail damage. Farmers in the Bayonne region of France have used ground generators for the same purpose. The theory of hail prevention is that, by precipitating out moisture at earlier stages, cloud seeding can prevent large hail-producing storms from developing. The same theory applies to lightning prevention and thus has interest for fighting forest fires. Some cloud-seeders in the United States like hail-prevention projects because while farmers do not always want more rain they almost always want to prevent hail if they can. Thus such projects sometimes get a steadier financial support.

Formosa and Sweden have undertaken projects to increase hydroelectric power. Owners of sugar plantations in Cuba have financed rain-increasing projects despite an average of more than 1200 mm inches of rainfall a year. Additional rainfall means additional sugarcane for them.

Much of the work in foreign countries has been of high caliber. But it still has not supplied the answers.

Analysis of experiments will produce some answer helpful to farmers and other water users in deciding whether weather control activities are a good bet or not. But the real and positive answers will come from further research into rainfall processes. The sky is wild,

unpredictable laboratory; research in weather is difficult and often frustrating. All the same, science moves inexorably onward, learning more and more about the possibilities for modifying or controlling weather.

Perhaps these possibilities will narrow down to certain limited applications. It is conceivable, though, that weather control can become a regular feature of crop production.

Russian Air Force used this technique on 9th May 2005, to prevent rain on Moscow city celebrating freedom festival. A group of eleven planes of Air Force of Russia flying at a high 3000m – 8000m spray silver iodide, liquid nitrogen and dry ice in air at 50 to 150 km away from Moscow city. Due to this spray rainfall before the cloud reach to Moscow city. The event was very important, as leaders from 53 countries were present in this celebration.

### 13.2 REVERSE OSMOSIS

The acute shortage of water in future will be at such a level that the man has to turn to fetch whatever the water is available on the earth. The only alternative left out in the use of seawater, which is highly salty. It is strong belief that in future due to the scarcity of the sweet water, the sea water available in plenty will definitely survive the living being on the earth. The seawater will be used as a supplement to the available sweet water.

The seawater can be converted into sweet water by the following modern technological processes.

- (1) Distillation
  - Multistage flash distillation (MSF)
  - Cold distillation
  - Vapour compression and MSF
- (2) Reverse Osmosis

All these processes are very expensive and distillation and demineralization is more expensive than Reverse Osmosis process. To survive in future, the treatment cost will not be the criteria but the most importance is to have the availability of water

As in future, looking to the increased use of the seawater, the technocrats have developed and still working for technologies development of seawater treatments. Amongst the seawater treatment processes, the Reverse Osmosis process is being used extensively because of its reliable results and less costlier as compared with the other seawater desalination processes.

#### ***General Aspects of Pretreatment***

Feed water pretreatment is probably the most important factor in contributing to successful RO plant operation. Pretreatment system is designed for a particular feed water. The extent type of treatment depends on the feed water quality and quantity, membrane type and configuration. There is no universal method of pretreatment which can cover all situations. Pretreatment should ensure removal of suspended and dissolved materials such as organic and inorganic particles, iron, manganese and other undesirable constituents.

The treatment is usually conventional. Coagulation and flocculation, filtration, fine mesh cartridge filter are very commonly used. Inhibitors or pH control is used to prevent scaling and reduce the rate of  $\text{Fe}^{++}$  oxidation. Sulphuric or hydrochloric acid is used for pH adjustment.

Chlorination is also done. In case of polyamide membrane, chlorination is followed by dechlorination.

So it is absolutely essential that the feed water be thoroughly analyzed before setting up of the RO plant.

The major pretreatment requirement for any reverse osmosis device is to prevent the membrane to 'fouling'. The phenomenon of fouling is complex and is complicated which involves the trapping of some type of material within the reverse osmosis device itself or on the surface of the membrane.

Since the causes, symptoms and cure are different; following five potential problems should be considered before designing the pretreatment units.

- (1) Membrane scaling
- (2) Metal oxide precipitation
- (3) Device plugging
- (4) Colloidal fouling
- (5) Biological growth inside device

### ***Principles of Reverse Osmosis***

The reverse osmosis process can be described by considering the normal osmosis process. The classical demonstration of osmosis involves fixed quantities of two solutions of different concentration separated by a semi-permeable membrane, which is permeable to the solvent (water) and impermeable to the solute (dissolved salts). The more concentrated solution is contained in a closed vessel, which is fitted with a pressure gauge. The less concentrated solution; generally pure water is contained in a vessel open to the atmosphere. At zero time, the levels of the two liquids are equal. As time passes, the levels of the pure water falls at a decreasing rate while that in the closed vessel rises correspondingly, thereby increasing the pressure of the gauge. The flow of solvent from lower concentration to higher concentration ceases when the concentration of the solvent is equal on both sides of the membrane. At such an equilibrium stage, the hydrostatic head developed is referred to as the "OSMOTIC PRESSURE", or the difference in the osmotic pressure between the two solutions.

If a pressure in excess of the osmotic pressure is now applied of the more concentrated solution chamber, pure solvent is caused to flow from this chamber to the pure solvent side of the membrane, leaving a more concentrated solution behind. This phenomenon is the basis of the reverse osmosis process. The figure shows the principles of reverse osmosis (Figs 13.1, 13.2 and 13.3).

**OSMOSIS**

When fluids of different concentrations in a vessel are separated by a membrane, the dilute solution will flow through the membrane into the concentrated solution.

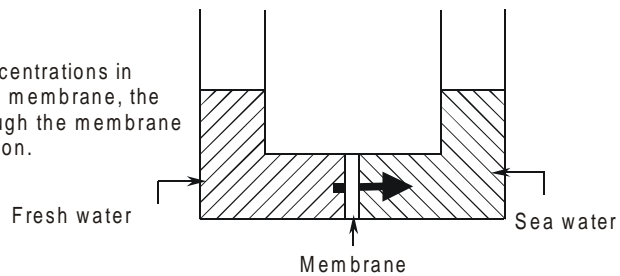

**Fig. 13.1 Principle of osmosis.**

**OSMOTIC PRESSURE**

The level of the dilute solution drops and the level of the concentrated solution rises until an "equilibrium" is reached. The pressure difference between these two levels is the "osmotic pressure".

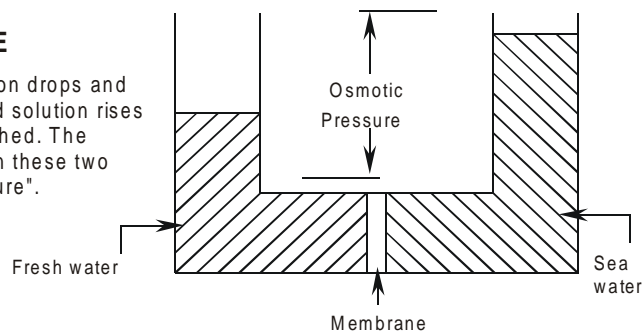

**Fig. 13.2 Osmotic pressure.**

**REVERSE OSMOSIS**

If a pressure in excess of the osmotic pressure is applied to the concentrated solution, the flow is reversed from the concentrated solution to the diluted solution. This is "reverse osmosis".

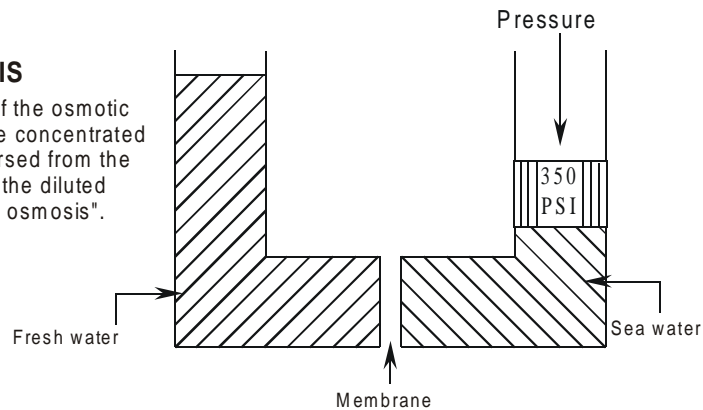

**Fig. 13.3 Osmosis reverse.**

**Operation of Reverse Osmosis System**

Reverse osmosis employs a semi-permeable membrane and a pressure driven mechanism to drive fresh water to one side of the cell, while concentrating salts on the input or rejection side of the cell in this process, fresh water is literally squeezed out of the feed water solution.

Fig. 13.4 shows the simplest arrangement of a reverse osmosis system consisting of high pressure pump to pressurize the feed water, a membrane element, a pressure vessel to house the membrane element, and regulating valve to control the flow and pressure. Normally a

reverse osmosis system is employed with some pre-treatment and post treatment. The pre-treatment is required to remove suspended solids, colloids, metals, etc. to avoid fouling and choking of the membrane surface which otherwise reduces the water flux. Post-treatment usually consists of pH-adjustment and chlorination or depends upon end-product reuse.

Most reverse osmosis systems in use today employ semi-permeable “asymmetric membranes” made from cellulose acetate or polyamide, or “composite membranes” made with a dense thin polymer coating on a sulfone support film. The dense rejecting skin of the composite membranes can be up to 10 times thinner than the skin of the cellulose acetate membranes.

The rejection of the dissolved species depends not only on the size of the rejected species, but also on the chemistry of the membrane and the rejected species. The rejection of low molecular mass is generally low with the asymmetric cellulose acetate and polyamide membranes while with composite membranes; moderate to good rejections can be obtained with many intermediate and even low molecular mass organics.

The percent rejections tend to be constant over a wide range of concentrations while only the applied pressure will have to be varied. The concentration in the water passing through the membrane will be proportional to the concentration retained. The higher the fraction of feed which passes the membrane, that is, the higher the “recovery” of water, the higher will be the concentration in the product water. The retained water is often termed the “concentrate” and the product water the “permeate”.

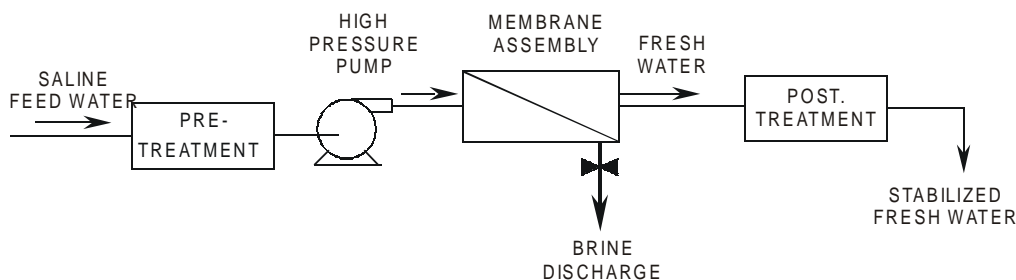

*Fig. 13.4 Flow diagram of reverse osmosis system.*

### **Membrane for Reverse Osmosis**

The selection of polymers for reverse osmosis membranes is a formidable task. For selection of each membrane material, the parameters as method of preparation, molecular weight distribution, and pre-treatment will decidedly influence the final properties of the membrane. Since, the goal is a membrane that will ensure good, reliable performance in a commercial permeator, a specific polymer type must be selected and its production must be undertaken on a commercial scale.

### **Performance Criteria for Reverse Osmosis Membranes**

- (1) Hydrophilic membrane, which selects water molecules over ions (governs the number of pressurized stages needed to produce potable water).
- (2) Good salt rejection ability.

- (3) Permeation rate of water per unit pressure gradient which determines the size of equipment per unit production rate of potable water.
- (4) Membrane durability which determines the replacement rate of membrane.
- (5) Capability of being fabricated with high surface to volume ratio (hollow fibers, thin films).
- (6) Wide operating range
  - : (a) Ion content of water source.
  - : (b) Pressure
  - : (c) Temperature
  - : (d) Operating pH – range
- (7) Resistance to chemical agents, heat and biological attack.
- (8) Low cost.
- (9) Versability to fit different requirements.

Indeed a large variety of membranes have been developed. The different membranes available are:

- (1) Cellulose acetate membranes.
- (2) Polyamide membranes.
- (3) Thin film composite membranes.
- (4) Dynamic membranes.

**Table 13.1 Comparison of different membrane modules**

<i>Characteristics</i>	<i>Plate and Frame Module</i>	<i>Tubular Module</i>	<i>Spiral Wound Module</i>	<i>Hollow Fine Fibre</i>
Packing density (sqft/cuft)	50 (Low)	100 (Low)	300 (High)	5000 (Highest)
Suspended solids tolerance	High	High	Fair	Poor
Pretreatment	Flexible in pretreatment	Flexible in pretreatment	Extensive pretreatment is required.	More extensive pretreatment
Cost	Very expensive at large scale operations	High capital cost due to low packing density	Low manufacturing cost.	Cost is lower than all
Cleaning of membrane	Easy cleaning	Very good in cleaning by mechanical and hydraulic means.	Easy cleaning, chemically and hydraulically.	Difficult cleaning due to very small spacing between fibers.
Assembly and replacement	Appreciable manual labour is required for membrane assembly and replacement	Difficult to handle large number of tubes and lack of membrane replacement technology.	Factory assembly and easy field replacement.	Skilled assembly required.



### 13.3 R.O. PLANT AT THERMAL POWER STATION AT SIKKA, GUJARAT, INDIA

A case study for large Reverse Osmosis Plant Thermal Power Station at Sikka, Jamnagar is selected to study the Reverse Osmosis plant. Thermal power station having the total water requirement of 30,00,000 litres/day for its boiler feed water and service water for its plant and housing colony. The housing colony is having a population of 3100 and the domestic water requirement is 10,00,000 liters of this total demand only 16,00,000 litres/day (Av.) water quantity is available from nearby Sasoi dam. In water scarcity because of the scarce rainfall in some of the years, the Sasoi dam water storage was not adequate. An available groundwater is also saline like the sea water because of near by location of Arabian sea. This shows the inadequacy of the groundwater hence an alternative was the use of sea water which is available adjacent to the Thermal power station.

The seawater is diverted through an excavated channel and further treated by the Reverse Osmosis process. In the Reverse Osmosis process limiting parameters to the Reverse Osmosis feed water are as follows for spiral modules (Table 13.2).

**Table 13.2 Limiting parameters**

<i>Parameters</i>	<i>Limitations</i>
Turbidity	Less than 1 NTU
Free chlorine	Nil
Iron, manganese	Less than 0.05 ppm
Bacteria and organics	Nil
Oil and grease	Nil
Temperature	Less than 45° C
Silting index	Less than 4.0
pH	3 to 10

**Table 13.3 Analysis of Arabian sea water sample**

<i>Parameters</i>	<i>Results</i>
TDS, ppm	38,926
Turbidity, NTU	30
pH	8.2
P-Alkalinity as CaCO <sub>3</sub> , ppm	NIL
MO-Alkalinity as CaCO <sub>3</sub> , ppm	116
Chloride as chloride ppm	21,500
Chloride as CaCO <sub>3</sub> , ppm	30,315
Total hardness as CaCO <sub>3</sub> , ppm	6800
Calcium hardness as CaCO <sub>3</sub> , ppm	1050
Magnesium hardness as CaCO <sub>3</sub> , ppm	5750
Sulphate as sulphate, ppm	3000

*Contd.*

<i>Parameters</i>	<i>Results</i>
Sulphate as CaCO <sub>3</sub> , ppm	3120
Silica (dissolved) as SiO <sub>2</sub> , ppm	1.2
Corrected conductivity at 25°C µmhos/cm	61800
Residual chlorine, ppm	—
Free CO <sub>2</sub> as CO <sub>3</sub> , ppm	15
Free CO <sub>2</sub> as CaCO <sub>3</sub> , ppm	17

It clearly seems from the above two tables (Table 13.2 & 13.3) of requirement of Reverse Osmosis feed water and sea water analysis, that extensive pretreatment before the actual Reverse Osmosis process is very essential. The pretreatment comprises of coagulation, sedimentation, filtration, chlorination and dechlorination. The pretreatment or unit operation is a costly process but is a must for running Reverse Osmosis process very smoothly. If the cost of the total Reverse Osmosis process is say 10 Rs. / lit, the approximately 7 Rs. / lit is the unit operation cost and rest 3 Rs. / lit is the cost Reverse Osmosis process. As a total solid contains of the seawater is very high (38,000 – 42,000 ppm) a very high pressure (60 – 65 Kg / sqm) is required to have the reliable results of the Reverse Osmosis effluents.

As per the requirement of the Reverse Osmosis feed water, the primary treatment to the Sea water is given by

- (1) Chlorination followed by coagulation and flocculation with FeSO<sub>4</sub>, cation polyelectrolyte and recirculation of settled sludge.
- (2) Sedimentation and filtration.
- (3) Activated carbon filter.
- (4) Micron cartridge filter.

The post-treatment degasification by degassifier.

Following are the pretreatment units

- (1) Flash mixer.
- (2) Sludge blanket type clariflocculator with sludge recirculation system.
- (3) Rapid gravity dual media filter.
- (4) Sludge collection sump and disposal system.
- (5) Activated carbon filter (ACF).
- (6) Chemical dosing system.
- (7) Micron cartridge filter (MCF).

### **Reverse Osmosis Process**

**High pressure pump:** High pressure pump is used to feed the filtered and pretreated water to the reverse osmosis unit at high pressure. This is horizontal multistage centrifugal pump made of S.S. provided with a butterfly valve at the suction and check and globe valve at the discharge. The electric motor drive of the pump is coupled with an energy recovery turbine at the back.

The high pressure pump is provided with suction and discharge pressure gauges to indicate respective pressure and pressure switches at the suction and discharge of pumps to prevent the pump from operating in the event of low suction or high discharge pressure. There are residual chlorine analyzer, pH meter, temperature indicator in common suction header while temperature indicator and high pressure switch at common discharge header.

**Data:**

Nos.	: 3 working + 1 standby.
Capacity (cu.m/hr)	: 215
Head (kg./sq.cm)	: 64.35
Liquid to be handled	: Filtered Sea Water
Type	: Multistage Centrifugal Horizontal.

**Motor:**

Nos.	: Four
kW / rpm	: 600 / 2975
Supply Voltage	: 6600 V, 3 Phase 50 Hz

**Energy recovery turbine (ERT):** This system is provided to take advantage of highpressure energy of high-pressure pumps. The highly pressurized rejected water is fed into reverse pump type turbine which in turn produces rotation power output used to assist main electric motor in driving the high pressure pump thus saving a very considerable proportion of power to drive the pump.

This system is directly coupled with motor shaft. Reverse Osmosis rejected water is fed to it. It is provided with actuated globe valves at suction and globe valve at discharge. The discharge water is sent to reject storage tank.

**Data:**

Nos.	: 3 working + 1 standby.
Material of construction	: DUPLEX – SS
Capacity (cu.mt/hr)	: 135
Inlet pressure (psig) (min./max.)	: 850/900
Liquid to be handled	: RO Reject Water.

**Reverse osmosis unit:** RO unit is provided to reduce dissolved solids from the RO feed water and to get the purified water (permeate water). The permeate water is then passed through degassifier. The reject water is then passed through the energy recovery turbine to save the considerable amount of electric power.

RO feed water, under high pressure, enters into pressure tubes of the RO unit which passes through the RO membrane elements. The permeate travels through the header whereas the concentrated reject water, which contains very high dissolved solids passes through Energy Recovery Turbine (ERT) and then collected in reject water storage tank. The reject water is used for backwash of Activated Carbon Filter (ACF) and Rapid Sand Filter (RSF).

The Reverse Osmosis Unit consists of three stream (A,B & C). Each stream consists of four sub-streams of six pressure tubes each in single pass array. Each pressure tube contains six membranes elements which are interconnected inside the pressure tubes with help of “O” rings placed in the interconnectors.



*Fig. 13.5 RO Unit at thermal power station.*

**Data:**

No. of stream	: Three (RO – A / B & C)
No. of substream	: Four (RO – A / B / C – 1/2/3/4)
No. of pressure tubes	: Six/Substream
Membrane type	: 8040 HYS SWCI
No. of membrane element	: Six/Pressure Tube
Total no of pressure tube	: 72
Total no of membrane element	: 432
Length and size of pressure tube	: 12.4m
Flow array	: Single pass
Max. feed flow (cu.mt/hr)	: 53.7
Operating pressure (kg/sq.cm)	: 64.35
Max. permeate flow (cu.mt/hr)	: 15.3

**Degasser tower (DGT):** Degasser tower is an atmospheric tower provided for removal of residual gases like carbon dioxide. It is made from mild steel rubber lined (MSR/L) internally and provided with polypropylene pall rings supported on MSR/L coated tray. To distributes the incoming water from the top header the lateral type of distribution system is provided.

The bottom tray distributes the draft of low-pressure air from the blower from top and going upwards. Packing is provided to increase the surface area by breaking the water.

**Data:**

Nos.	: Two
Diameter (mm)	: 1400
Height (mm)	: 3000
Material of construction	: MSR / L
Type of packing	: Polypropylene pall rings

**Degasser air blower:** Degasser air blower is provided for blowing the air the bottom of degasser tower and carbon dioxide from permeate water is removed by this blown up air.

**Data:**

Nos.	: Two + Two standby
Type	: Centrifugal
Capacity (cu.m/min)	: 46.2
Head (mm WC)	: 50

**Motor:**

Nos.	: Four
kW / rpm	: 1.5 / 1400
Supply voltage	: 3 Phase. 415 V AC, 50 Hz

**Caustic soda (NaOH) dosing system:** Caustic soda (NaOH) may be dosed in the permeate water after degasification to increase the pH of water to make it suitable for further use. Sometimes it may happen that pH of the RO feed water is acidic and hence the permeate water is also having low pH value. This low pH value water is not suitable for further domestic, drinking or other use and hence if the permeate water is having low pH value then only caustic dosing system is need based applicable.

**Permeate storage tank (PRST):** Permeate storage tank is provided with an inlet for degassed water, outlet leading to overflow, drain connections and level indicating transmitter, permeate transfer pump suction, permeate flushing pump suction.

To pump the degassed water from permeate storage tank permeate transfer pump is provided with pressure gauge and non – return valve at the discharge line.

**Data:**

Nos.	: One
Material of construction	: MSR / L
Diameter (mm)	: 3600
Length on straight (mm)	: 5000
Liquid to be handled	: Degassed permeate water

**Pump:**

Nos.	: Two + One standby
Type	: Horizontal centrifugal
Capacity (cum / hr)	: 93
Liquid to be handled	: Degassed permeate water

**Motor:**

Nos.	: Three
kW / rpm	: 7.5 / 2915
Supply voltage	: 3 phase, 415 V Ac, 50 Hz

**Reject water storage tank (RJST):** Reject water storage tank is provided to store the reverse osmosis rejected water which can be used for back washing of activated carbon filters and rapid gravity dual medial filter by operating the rejected water transfer pumps.

**Data:****RJST**

Nos.	: One
Dimensions (mm)	: 12500 × 8000 × 2500 LWD
Material of construction	: RCC

**Pump:**

Nos.	: Two + Two standby
Type	: Vertical turbine
Capacity (cum / hr)	: 265
Liquid to be handled	: Rejected water

**Motor:**

Nos.	: Four
kW / rpm	: 30 / 1500
Supply voltage	: 3 Phase, 415 V Ac, 50 Hz

**Cleaning system:** To remove foulants from the RO membrane element and to fill up the pressure tubes with disinfectant solution, cleaning system is provided. Cleaning system comprises the following.

- (1) Cleaning solution tank (CST)
- (2) Cleaning solution pump.
- (3) Micron cartridge filter.

**(1) Cleaning solution tank:** Cleaning solution tank is provided with high-speed mixer, gauge glass type indicator, overflow and drain piping.

**Data:**

Nos.	: One
Material of construction	: MSR / L
Diameter (mm)	: 1600
Depth (mm)	: 2600
Liquid to be handled	: Cleaning solution

**Agitator:**

Nos.	: One
Type	: Top mounted three blade propeller type.

**Motor:**

Nos.	: One
kW / rpm	: 1.50 / 925
Supply voltage	: 3 Phase, 415 V Ac, 50 Hz

**(2) Cleaning solution pump:** Pump is provided to recirculate cleaning solution from the tank to the micron cartridge filters to reverse osmosis elements and back to the tank. Pump is complete with suction discharge valves and piping and pressure gauge.

**Data:**

Nos.	: One + One standby
Type	: Horizontal centrifugal
Capacity (cu.m/hr)	: 55
Head (kg/sq.cm)	: 3.0
Liquid to be handled	: Cleaning solution

**Motor:**

Nos.	: Two
kW / rpm	: 15 / 1470
Supply voltage	: 3 Phase, 415 V Ac, 50 Hz

**(3) Micron cartridge filter:** The micron cartridge filter is provided for removing the suspended particles from the cleaning solution upstream of the Reverse Osmosis unit during cleaning Solution application. The filter cartridge must be replaced when differential pressure across the cartridge filters approaches 1 kg /sqcm or when the flow rate reduces, which ever occurs earlier.

**Data:**

Nos.	: One + One Standby
Material of construction	: MSR / L
Diameter (mm)	: 400
Height on straight (mm)	: 1150
Filtration size (micron)	: 10
Nos. of element in each	: 14

**Operating Consideration for RO**

Observe the following general operating points in day use of RO system.

1. Check the RO flow adjustment at least once in every shift and readjust if needed.
2. Check the chemical dosing and readjust if required.
3. SHMP dosing is very important to inhibit the formation of scale within the RO membrane element so analyze the brine sample and adjust the dosing accordingly.

4. For solving any operational problem during normal use maintain the log sheet accurately.
5. Regular visual inspection, repairs of any leaks, cleaning and touch of painting should be done for preventive maintenance.
6. Do not operate RO system at reduced capacity.

#### **Change in Parameters After RO Process**

After Reverse Osmosis process significant changes found in the following parameters.

**Table 13.4 Effect of RO process on different parameters**

<i>Parameters</i>	<i>Before</i>	<i>After</i>	<i>Percentage reduction</i>
TDS, ppm	38,972	457	98.82
Chloride as chloride, ppm	21,550	264	98.77
MO – Alkalinity as CaCO <sub>3</sub> , ppm	96	6	93.61
Total hardness as CaCO <sub>3</sub> , ppm	6800	12	99.82
Calcium hardness as CaCO <sub>3</sub> , ppm	1050	2	99.80
Sulphate as SO <sub>4</sub> , ppm	3000	10	99.66
Silica (dissolved) as SiO <sub>2</sub> , ppm	1.2	0.2	83.33
Conductivity (corrected) at 25° C µmhos/cm	61,950	725	98.88
Free CO <sub>2</sub> as CO <sub>2</sub> , ppm	12.32	2.65	78.49

#### **13.4 LOW TEMPERATURE THERMAL DESALINATION (LTTD) PLANT**

The temperature difference which exists between the surface layer (28 ~ 30°C) and deep sea layer (7 ~ 15°C) of the ocean could be effectively utilized to produce potable water apart from power generation, air conditioning and aquaculture. This technology is known as Low Temperature Thermal Desalination. In Low Temperature Thermal Desalination, relatively warm water is flashed inside a vacuum flash chamber and the resultant vapour is condensed in a condenser using cold water. This technology has been utilized in the first ever-low temperature thermal desalination plant, which has been commissioned at Kavaratti.

The plant is housed in a structure on the shore. The bathymetry at the island is such that 400m water depth is available around 400m from the shore. Due to this special feature a long pipe about 600m long to draw cold water has been deployed with one end at about 350m water depth. Refer Fig. 13.6 for lay out and Fig. 13.7 for conceptual cross-section.



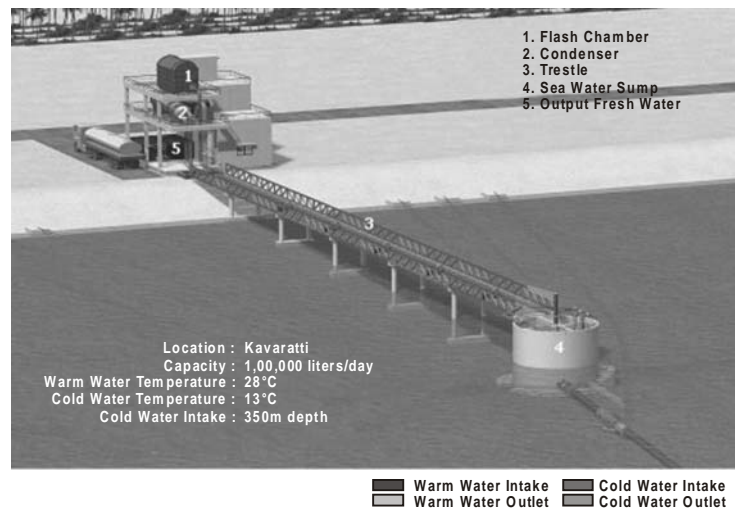

**Fig. 13.6** Lay out of LTTD plant at Kavaratti.

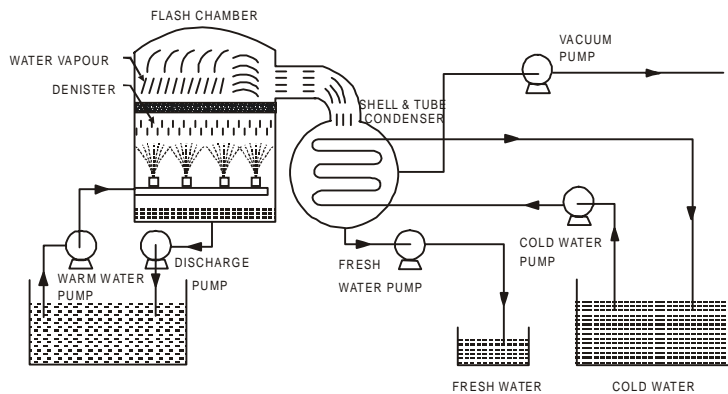

**Fig. 13.7** Conceptual cross-section of LTTD plant.

Though the concept was known for a long time, due to practical difficulties, it was never attempted.

This approach of providing water is extremely useful for islands like Kavaratti where there is no other source of fresh water and the environment is extremely fragile.

#### **Features of LTTD Plant**

- Doesn't require pre-treatment of feed water.
- Assured consistent quality water as per BIS/WHO standards
- Operational simplicity and easy maintenance
- No environmental (chemical or thermal) pollution
- Highly nutrient cold water enhances marine life

This opens a new vista for setting up much larger barge mounted desalination plants to address our ever-increasing need for potable water.

### ***Floating Desalination Plant***

- The Fresh water produced is of very good quality.
- The production rate was 1 lakh litres per day and the plant was continuously run for 10 days.
- The deepest single point mooring (400m depth) in India was achieved.
- All cold water pipe and mooring components were recovered safely at the end of the experiment.
- Currently floating plant of 5 to 10 MLD capacity is being designed for main land requirement.
- Such larger rating barge mounted plants are expected to produce water at costs less than 9 paise/litre.

### **13.5 AFFORDABLE DESALINATION**

The affordable desalination small structure erected on a tiny house of Kerala coastal bed yielding potable water having TDS 109 ppm from air moisture. This portable light weight plant is simple, low cost and window like structure made from aluminium and glass.

Each panel costs around Rs. 600. On a good sunny day, it can produce two litres of potable water. Most of the wells on the coastal belt yield saline water due to upcoming. Fresh water availability in coastal belts is rapidly declining. The shallow fresh water aquifers are replaced by saline water (Terry Thomas, 2005).

#### ***The Apparatus***

The present model occupies an area of about 0.7 square meters. Major parts are of aluminum. It has two frames. The upper frame fitted with a glass, rests above the lower base with the help of hinges. Lower frame, made of aluminum sheet has thermocol insulation. Fine sand is spread above the aluminum sheet. Row water enters the system through low-head distribution pipes and soaks the sand layer to its field capacity. The upper glass frame, like a windowpane, fits correctly on the lower base. Using a few 'C' clamps, it is made airtight.

#### ***Solar Distillation***

Sunlight falling through the glass panel heats up the sand. Water slowly evaporates and the vapour condenses on the inner side of the glass sheet.

The still is kept at an angle such that, the condensed vapour slowly flows out of the outlet of the still. This is then transferred to a utensil through a pipe.

#### ***10 Litres a Day***

After a thorough survey, it was found out that an average family could manage their drinking and cooking needs with 10 liters of water per day. Five panels would be required to provide

this much of water. The cost would be around Rs. 3000. According to Planet Kerala workmen, these stills can be made out of locally available materials by any person with some basic fabrication aptitude. Once installed, there is no recurring or maintenance cost. Rewashing of deposited salt and maintenance is very simple and easy. For the cloudy days in monsoon a guiding angle made of aluminium at the lower side of the glass panel is provided for catching rain.

It is time for the government and NGOs to adopt such system for pilot studies. A couple of stills can be installed in houses where family members can take interest and observe the results carefully. Subsequently, amendments improvements can be made in the panels after obtaining the vital feedback.

### **13.6 NET IS USED TO CAPTIVE WATER**

There are used various kind of techniques used to save and also collect the water. In this case many countries in the universe carried on their experiment till now. Through the experiment a scientist of Chellie has found out a process that is cheap and as easy as ABC.

This process helps to convert vapour into water with the use of this process, scientists Pilar Serecidany has the ability to collect the water if it is not raining. In the epicenter of this process he has used net which is as like as volley-ball net, when the air which is fall of vapour are passing through the net then the vapour which is attached with the net, and then the vapour converted into little bit of water that trickles into a half-rounded pipe. A thin pipe also attached with this pipe is connected with a water tank that is situated in a village, which is far from the place. The net is made with polypropylene or plastic. The net is 12 metres long and whose height is 4 metres. This net is used in Chellie's water collecting process. Generally these nets are spread in mountainous valleys. When the air, which is fall of vapour, is passing through the net then each drop of water becomes as precious as gold. At Chungungo Chellie's forest department with the use of 75 nets collects 10000-litre water everyday. This process is so simple, easy and effective. To fulfill their thirst the villagers fetched the water from so kilometers far away, with the use of this technique now Chungungo is looked like as green as grass. This process is easy, simple which does not need extra researches on it. According to scientists to convert salted water to normal drinking water this process is better than other expensive processes. In the deserted area, this process is worth. Coming through the successive way with the use of this technique at Chango sercidae claimed that this process has the ability to prevent the scarcity of water in India and other countries in the world.

## REFERENCES

---

- Abu Sharekh M S (2002) Rainwater roof catchment systems for household water supply in the West Bank, *Hydrology Journal*, 25 (4), December, pp 31- 40. Indian Association of Hydrologists, Roorkee, India.
- Adams B (1980) Saline intrusion — A brief literature study, Report No. WD/ST/8D/1, British Geological Survey, Wallingford.
- Agarwal A (2000) Drought? Try capturing the rain, an occasional paper from the Centre for Science and Environment, New Delhi, India. pp 1-16.
- Allan J A & Karshenas M (1996) Managing environmental capital: The Case of Water in Israel, Jordan, the West Bank and Gaza, 1947 to 1995, in Allan, J.A. & Court, J.H. (Eds.) 1996. *Water, Peace and the Middle East: Negotiating Resources in the Jordan Basin*. I.B. Taurus Publishers: London
- Allan J A & Mallat C (1995) *Water in the Middle East: Legal, Political and Commercial Implications*, London: British Academy Press.
- Allan J A & Radwan L (undated) *Perceptions of the Values of Water and Water Environments*. Proceedings of the 4th European Seminar on Water Geography. London: Middlesex University and SOAS.
- Allan J A (1994) Overall perspectives in countries and regions, in Rogers, P. & Lydon, P. (Eds.). 1994. *Water in the Arab World: Perspectives and Progress*. Harvard University Press: Cambridge.
- Allan J A (1996) Water use and development in arid regions: Environment, Economic Development and Water Resource Politics and Policy, in *Water Use and Development*, Vol. 5, No. 2; 107-115.
- Allan J A (1998) ‘Virtual water’: An essential element in stabilizing the political economies of the Middle East. *Yale University Forestry & Environmental Studies Bulletin*, No. 103; 141-149.
- Allan J A (1998) Virtual water: A strategic resource global solutions to regional deficits. In *Groundwater*, Vol. 36, No. 4 ;545-546.
- Allan J A (1998) Why value water? Some perspectives on the political economy of water and the environment in the mediterranean region. In Ferragina, E. (Ed.) 1998. *L’Aqui nei paesi Mediterranei*. Proceedings of the International Convention held in Naples on 4-5 December 1997.
- Allan J A (1999) Avoiding war over natural resources. In Fleming, S. (Ed.) *War and Water*. Geneva: ICRC Publication Division.

- Allan J A (1999) *Global systems ameliorate local droughts: Water, Food and Trade*. Paper presented at the Exploratory Workshop on Drought and Drought Mitigation in Europe, 1-3 March 1999, Space Applications Institute, European Commission, DG Joint Research Centre.
- Allan J A (1992) Substitutes for water are being found in the Middle East and North Africa, in *GeoJournal*, Vol. 28, No. 3: 375-385.
- Andrews R W (1981) Salt-water intrusion in the Costa de Hermisillo, Mexico: A numerical analysis of water management proposals. *Groundwater*, 19(6), 635-647.
- Apello C and Geirnaert W (1991) Processes accompanying the intrusion of salt water. In *Hydrogeology of Salt Water Intrusion*, Vol. 11, W. De Breueck, (Ed.), International Association of Hydrogeologists, Hannover, pp. 291-303.
- Arceivala S J (1969) Reuse of water in tall building, Report on pilot study and design. AIC Pollution Control Division, Bombay, India.
- Arora C L and Rose R N (1981) Demarcation of fresh- and saline-water zones using electrical methods (Abohar area, Ferozepur district, Punjab). *Journal of Hydrology*, 49, 75-86.
- Asano T et al (1996) Evaluation of the California wastewater reclamation criteria using enteric virus monitoring data. *Water Science and Technology*, 26, 7 – 8, 1523-24.
- Ashton P and Haasbroek B (2000) Water demand management and social adaptive capacity: A South African Case Study. Forthcoming chapter in a book as yet untitled. Available in draft from the CSIR, Division of Water, Environment and Forestry Technology, P.O. Box 395, Pretoria 0001, South Africa.
- Athavale R N (2003) Water harvesting and sustainable supply in India, Centre for Environmental Education, Rawat Publication, Ahmedabad.
- Athavale R N, Muralidharan D and Rangarajan R (1994) Borehole injection studies in Deccan Trap Basalts near Nagpur — Proceedings of the Second International Symposium on ‘Artificial Recharge of Groundwater’, Ed. A. Ivan Johnson and R. David G. Pyne, pp.775-788.
- Bobba A G (1993) Mathematical models for saltwater intrusion in coastal aquifers, *Water Resources Management*, 7, 3-37.
- Bowen R (1986) *Groundwater*, 2nd ed., Elsevier Applied Science Publishers, London, 427 pp.
- Central Groundwater Board (1992) Proceeding of Workshop on Artificial recharge of groundwater — Lowcost rainwater management for increasing irrigation and groundwater recharge, pp 131. New Delhi, India.
- Central Groundwater Board (1994) Manual on artificial recharge on groundwater — technical series and No 3 pp. 215.
- CGWB, Govt. of India (1993) — Proceedings of the workshop on “Artificial Recharge of Groundwater in Basaltic and Sedimentary Rock Aquifers” held at Indore (M.P.), March, 1993.
- Chow VT (1964) *Handbook of Applied Hydrology*, McGraw Hill, New York.

- Cillie GG et al., (1967) Water pollution control federation, Washington DC, p 1-35, Proc. International Conference on Water Pollution.
- Cooper H J et al., (1964) Seawater in coastal aquifers, US Geological Survey—Water- supply paper 1613-C, USGS, pp. 84
- Custodio E (1985) Saline intrusion. In: Hydrogeology in the Service of Man, IAHS Publication No. 154 Volume I, IAHS, Wallingford, pp. 65-90.
- Das Gupta A (1983) Steady interface upconing beneath a coastal infiltration gallery. *Groundwater*, 21 (4), 465-474.
- Das Gupta A (1986) Simulated salt-water movement in the Nakhon Luang aquifer, Bangkok, Thailand. *Water Resources Journal*, 148, 35-44.
- Das Gupta A and Siddique M (1981) Hydrodynamic response of Nakhon Luang Aquifer, Bangkok, Thailand. *Groundwater*, 19 (5), 469-475.
- Das Gupta A and Yapa PNDD (1982) Saltwater encroachment in an aquifer: a case study. *Water Resources Research*, 18 (3), 546-556.
- Dave K N (2004) An integral study of major SIP structures in Saurashtra region, a dissertation submitted for postgraduate degree at M S University of Baroda, India.
- Drabbe J and Bandon-Ghyben W (1888-1889) Nota in verband met de voorgenomen putboring najib Amsterdam. In: Tijdschrift van het Koninklijk Institute van Ingenieurs. The Hague, Netherlands, pp. 8-22.
- Essaid H I (1986) A comparison of the coupled fresh water-salt water flow and the Ghyben-Herzberg sharp interface approaches to modeling of transient behaviour in coastal aquifer systems. *Journal of Hydrology*, 86, 169-193.
- Flavin R J and Joseph J B (1983) The hydrogeology of the Lee valley and some effects of artificial recharge- Q.J. Eng.Geol. London, 16,65-82.
- Floyd L et al., (1994) Recharge Well Technology at the Water Campus Project, Scottsdale, Arizona, Proceedings of the Second International Symposium on Artificial Recharge of Groundwater, Walt Disney World Swan, Florida, pp. 220.
- Freeze R A and Cherry J A (1979) *Groundwater*, Prentice-Hall, Englewood Cliffs.
- Geirnaert W and Laeven M P (1992) Composition and history of groundwater in the western Nile Delta. *Journal of Hydrology*, 138, 169-189.
- Gerges N Z, Sibenaler and Armstrong D (1994) Experience in Injecting Storm Water into Aquifers to Enhance Irrigation Water Supplies in South Australia, Proceedings of the Second International Symposium on Artificial Recharge of Groundwater, Walt Disney World Swan, Florida, pp. 436.
- Goldenberg LC (1985) Decrease of hydraulic conductivity in sand at the interface between seawater and dilute clay suspensions. *Journal of Hydrology*, 78, 183-199.

- Goldenberg LC, Mandel S and Magaritz M (1986) Water-rock interaction at the mixing zone between chemically different bodies of groundwater - implications for management of sandy aquifers. *Hydrological Sciences Journal*, 31, 413-425.
- Goldman MD, Gilad A, Ronen and A. Melloul (1991) Mapping of seawater intrusion into the coastal aquifer of Israel by the time domain electromagnetic method. *Geoexploration*, 28, 153-174.
- Gupta A B, Goyal Rohit and Dhotre S T (2006) Optimum design of *Kund* of rainwater harvesting — A case study of Churu, Rajasthan, 38th Annual Convention, IWWA, Jaipur, pp 223 – 227.
- Headworth H and G Fox (1986) The South Downs Chalk aquifer: its development and management. *Journal of the Institute of Water Engineers and Scientists*, 40, 345-361.
- Hem J D (1970) Study and interpretation of the chemical characteristics of natural water, USGS Water Supply Paper 1473, USGS.
- Henry H R (1960) Salt intrusion into coastal aquifers. In: IASH Publication No. 52 Commission of Subterranean Waters, IASH, Wallingford, pp. 478-487.
- Herzberg B (1901) Die Wasserversorgung einiger Nordseebäder. *Jour. Gasbeleuchtung and Wasserversorgung*, 44, 815-819, 842-844.
- Hillel I Shuval (1977) *Water Renovation and Reuse*, Academic Press, New York.
- Hubbert M K (1940) The theory of groundwater motion. *Journal of Geology*, 48, pp. 785- 944.
- Huisman L and Olsthoorn T N (1983) *Artificial Groundwater Recharge*, Pitman Advanced Publishing Program, Boston.
- Huisman L and F W J Van Harren (1966) Treatment of water before infiltration and modification of water quality during its passage underground — International Water Supply Association, Seventh Congress, Barcelona, 1966, pp.G1-26.
- Idris H and Nour S (1990) Present groundwater status in Egypt and the environmental impacts. *Environmental Geology and Water Science*, 16 (3), 171-177.
- International Association of Scientific Hydrology (1967), Artificial recharge and management of aquifers, Symposium, Haifa Publication, No. 72.
- Jacobson P J, Jacobson K M and Seeley M K (1995) *Ephemeral Rivers and Their Catchments: Sustaining People and Development in Western Namibia*. Windhoek: Desert Research Foundation of Namibia.
- James B. Flanigan, Paul A. Sorensen and Melanie A. Tucker (1994) Use of Hydrogeological Data in Recharge Pond Design, Proceedings of the Second International Symposium on Artificial Recharge of Groundwater, Walt Disney World Swan, Florida, pp. 139.
- Jawad Al-Sulaimi and Akashi Asano ( 2000) *Wastewater Reclamation and Reuse*, New Age International Pvt Ltd., New Delhi.

- John M, Dickenson P E and Steven B Bachman (1994) The optimization of spreading ground operations — Proceedings of Second International Seminar on ‘Artificial Recharge of Groundwater’, Ed. A. Ivan Johnson and R. David G. Pyne, ASCE Publications.
- Johnson A I and Pyne G (1994) Proceedings of Second International Symposium on Artificial recharge of groundwater – II, ASCE Publication, New York.
- K R Karanth and Srinivasa Prasad P (1979) Some studies on hydrologic parameters of groundwater recharge in Andhra Pradesh, J. Geological Society of India. Vol. 20 pp. 404-414.
- Kadam R V and Kelkar V N (2001) Water reuse, Indian Water Works Association, Proceedings of Water Crisis Management Seminar, pp. 39–52.
- Kanitkar M A (2002) Critical study on reuse of wastewater, A dissertation submitted for Post graduate degree at M S University of Baroda, India.
- Karanth K R (1987) *Groundwater Assessment Development and Management*, Tata McGraw Hill Publishing Co Pvt Ltd., New Delhi.
- Karmakar S M (2006) Affordable desalination, *Civil Engineering Today*, ASCE – IS, Vol 3, pp 12,
- Kashef A I (1971) On the management of groundwater in coastal aquifers. *Groundwater*, 21 (2), 12-20.
- Kashef A I (1977) Management and control of salt-water intrusion in coastal aquifers. *Critical Reviews in Environmental Control*, 7, 217-275.
- Kashef A I (1983) Salt-water intrusion in the Nile Delta, *Groundwater*, 21 (2), 160-167.
- Kelkar U et al., (2005) Wastewater recycle and reuse — A need of the hour in India, Indian Water Works Association, Theme: Sustainability of water and wastewater system, 37th Annual convention, Hyderabad, India.
- Kulkarni S Y, Rosal R L (1990) Contribution of percolation tanks in recharge of groundwater in Maharashtra state. All India Seminar on modern techniques of rain water harvesting conservation and artificial recharge, Pune.
- Lichtenthäler G and Turton A R (1999) *Water Demand Management, Natural Resource Reconstruction and Traditional Value Systems: A Case Study from Yemen*. Paper presented in the Workshop No. 4: Water and Social Stability of the 9th Stockholm. Water Symposium “Urban Stability through Integrated Water-Related Management”, hosted on 9-12 August by the Stockholm Water Institute (SIWI) in Stockholm, Sweden. Also available as Occasional Paper No. 14 from Website.
- Lichtenthäler G (1996) Tribes and trends: changing perceptions of the value of water in Yemen. In *Perceptions of the Value of Water and Water Environments*. Proceedings of the European Seminar on Water Geography. 6-10 September 1996, London, SOAS, University of London.
- Lichtenthäler G (1999) Water management and community participation in the Sa’dah Basin of Yemen: Politics, Perceptions and Perspectives. Preliminary Investigations for a World Bank Pilot Project.



- Lloyd J W, Howard K W F, Pacey N R and Tellam J H (1982) The value of iodide as a parameter in the chemical characterisation of groundwaters. *Journal of Hydrology*, 57, 247-265.
- Mc Gauhey P H (1968) *Engineering Management of Water Quality*, P 1450. McGraw Hill Co. New York.
- Metcalf and Eddy (1991) *Wastewater Engineering, Treatment, Disposal and Reuse*. 3rd edition, McGraw Hill, New York.
- Michael O' Shea (1994) Borehole recharge — a drought management strategy in N. London, UK, Proceedings of the Second International Symposium on Artificial Recharge of Groundwater, Walt Disney World Swan, Florida, pp. 210.
- Mistry J F (1988) Important aspects of river valley projects, Vol. 1, *Hydrology and Water Planning*, Mahajan Book Distributors, Ahmedabad.
- Modi P N (1990) *Irrigation Water Resources and Waterpower Engineering*, Standard Book House Publication, Delhi, India.
- Muralidharan (1997) Captive sustainable drinking water source well and wasteland development in hard rock areas – Proceedings of National Conference on “Emerging Trends in the Development of Sustainable Groundwater Sources”, August 27 & 28, 1997, J.N.T.U., Hyderabad.
- Murlidharan D, Athavale R N (1998) Artificial recharge in India, Proceeding of Base Paper, NGRI, Hyderabad, India.
- Nair C. (1991) Bangkok's deteriorating groundwater. *Waterlines*, 9 (3), 21-23.
- Nauras A S (2004) Spot solution in contaminated aquifer by artificial recharge — A case study of Kanha project, Vadodara (Gujarat), A dissertation submitted for postgraduate degree at M S University of Baroda.
- Ohlsson L and Turton A R (1999) The turning of a screw: social resource scarcity as a bottleneck in adaptation to water scarcity. Proceedings of the 9th Stockholm Water Symposium. Available in Draft from Website.
- Ohlsson L (1999) Environment scarcity and conflict: a study of Malthusian concerns. Department of Peace and Development Research, Göteborg University ISBN 91-87380- 43-9.
- Okubo T and Matsumoto J (1979) Effect of infiltration rate on biological clogging and water quality changes during artificial recharge — *Water resources research*. pp. 1536 – 1542, 1616 – 1622.
- Okubo T and Matsumoto J (1979) Effect of infiltration rate on biological clogging and Water quality changes during artificial recharge — *Water Resources Research*, pp.1536-1542, 1616-1622.
- Panda N et al., (2005) Organic agriculture: Science and belief, pp 19-20, *Agrobios*, Vol 4, No. 4.
- Patel A S (2000) Development of performance indicators for artificial recharge structures in Saurashtra region of Gujarat. Ph. D. Thesis, M.S. University of Baroda, Vadodara.

- Patel A S and Parthasarathy G S (1997) Development and management perspective of coastal groundwater of Saurashtra Region, Gujarat — a paper published in National Workshop on Environmental Pollution and Control organised by K.L.E.S.'s College of Engg. and Tech., Belgaum, Karnataka, April 12-13, 1997.
- Patel A S and Parthasarathy G S (1997) Sustainable development of groundwater through NGOs—A Case Study of Saurashtra Region (Gujarat) — a paper published in National Seminar (NCGW-97) at Hyderabad (AP), J.N.T. University, Aug. 27-28, 1997
- Patel A S et al., (2003) *Manual of Water Harvesting*, GSFC Science Foundation, Vadodara, India.
- Patel A S and Parekh VP (2005) Effect of seawater intrusion preventive structures in Meghal basin of Saurashtra Region, *Hydrology Journal*, Volume 27, November 1-2, March — June 2004 Indian Association of Hydrologists (IAH) ISSN 0917-569X
- Patel A S and Parekh VP (2005) Effect of Sabli — netravati spreading channel to control Seawater Intrusion in Saurashtra Coast, National Conference on Sustainable Management of Water Resources at College of Agricultural Engineering and Technology Junagadh Agricultural University, Junagadh, published by Himanshu Publications at Udaipur and Delhi.
- Patel A S and Trivedi Ankita (2006) Water management of north Gujarat. 38<sup>th</sup> Annual convention IWWA, organized by IWWA, UNICEF, GTZ Germany, at Birla Auditorium, Jaipur
- Patra K C (2001) *Hydrology and Water Resources Engineering*, Narosa Publishing House, New Delhi.
- Phadtare P N et al., (1982) Report on concept, methodology and status of work, Pilot project on Artificial Recharge, Central Groundwater Board, Ahmedabad, India.
- Prasad P R, A Pekdeger and W Ohse (1983) Geochemical and geophysical studies of salt water intrusion in coastal regions. In Relation of Groundwater Quantity and Quality (Proceedings of the Hamburg Symposium, August 1983. IAHS Publ. No. 146, F. X. Dunn, G. Matthes and R. A. Gras, editors, IAHS Press, Wallingford, Oxon, pp. 209-218.
- Raghunath H M (2007) *Groundwater*, Third Ed. New Age International (P) Ltd., New Delhi
- Ranade (2000) A water harvesting manual for urban areas: Case Studies from Delhi: Publication Centre for Science and Environment, New Delhi.
- Rao K N et al., (1971) Potential evapotranspiration over India, Symposium on Water Resources, IISc, Bangalore, India, pp. 2-14.
- Revelle R (1941) Criteria for recognition of sea water in ground-waters. Transactions of the American Geophysical Union, 22, 593-597.
- Riddell J O (1933) Excluding salt water from island wells — a theory of the occurrence of groundwater on experience at Nassau, Bahama Islands. *Civil Engineering*, 3, 383-385.
- Roger E (1987) *Water Reuse and the Cities*, The University Press of New England, Printed in India by Scientific Publishers, Jodhpur.

- Rushton K R (1980) Differing positions of saline interfaces in aquifers and observation boreholes. *Journal of Hydrology*, 48, 185-189.
- Salvi N S (2002) Roof top rainwater harvesting for Mumbai, pp. 201 – 206, 34th Annual Convention of Indian Water Works Association, Bangalore.
- Segol G, Pinder G and Gray W (1975) A Galerkin finite element technique for calculating the transient position of the salt water front. *Water Resources Research*, 11(2), 343-347.
- Sharma and Sharma (2000) Multispectral analysis of satellite digital data to estimate roof area and rain water available for artificial recharge in Delhi area, Proceedings of national seminar on rain water harvesting, Delhi, May 22-23. Published by Central Groundwater Board, New Delhi, pp. 152-167.
- Shearer T R (1991) Saline intrusion at Valle San Quintin, Mexico BC: Geophysical borehole logs, Report No. WD/91/45R, British Geological Survey, Wallingford.
- Shuval H L and Katzenelson (1972) *Detection of Enteric Viruses in the Water Environment in Water Pollution Microbiology*, 47-71, Wiley, New York.
- Sikarwar R S, Rank H D and Subbaiah R (2005) Impact assessment of water harvesting structures in Ladudi watershed, Proceedings of sustainable Management of Water Resources, Himansu Publication, Udaipur, India, pp. 121-124.
- State of California (1978), Waste water reclamation criteria, California administrative code titled 22, Div. 4, Environment health, Dept of health services, Berkley, CA.
- Stnder and Funke (1967), Conservation of water reuse in South Africa, Chem. Engg. Prog. Symp. Series 63. Amer. Inst. Them. Engg. New York.
- Subramanya K (2002) *Engineering Hydrology*, Tata McGraw Hill Publishing Co. Ltd., New Delhi.
- Sukhija B S, Reddy D V, Nandakumar M V, and Rama (1997) A method for evaluation of artificial Recharge through percolation tanks using Environmental chloride, *Groundwater*, Vol. 35, No.1.
- Sukhija D S et al., (1997) Proceedings of Artificial Recharge Structures: evaluating their functional efficacy and evolving criteria for their siting. NGRI, Hyderabad, India.
- Tellam J H and Lloyd J W (1986) Problems in the recognition of seawater intrusion by chemical means: an example of apparent chemical equivalence. *Quarterly Journal of Engineering Geology*, 19, 389-398.
- Tellam J H, Lloyd J W and Walters M (1986) The morphology of a saline groundwater body: its investigation, description and possible explanation. *Journal of Hydrology*, 83, 1- 21.
- Tiwari and Srivastave (1983).
- Todd D K (1980) *Groundwater Hydrology*, 2nd ed., John Wiley & Sons, New York, pp. 535 .
- Trivedi D P (1999) Study of reverse osmosis plant for sea water, A dissertation submitted for Postgraduate degree at M S University of Baroda, India.
- Turton A R and Meissner R (2000) The hydrosocial contract and its manifestation in society: A South African Case Study. Forthcoming chapter in a book as yet untitled.

- Turton A R and Ohlsson L (1999) Water scarcity and social stability: Towards a Deeper Understanding of the Key Concepts Needed to Manage Water Scarcity in Developing Countries. Paper presented to the 9th Stockholm Water Symposium. Available in Draft from Website.
- Turton A R (1998) The hydropolitics of Southern Africa: The Case of the Zambezi River Basin as an Area of Potential Co-Operation Based on Allan's Concept of Virtual Water. Unpublished M.A. Dissertation, Department of Political Science, Pretoria: University of South Africa (UNISA).
- Turton A R (1999) Water scarcity and social adaptive capacity: Towards an Understanding of the Social Dynamics of Water Demand Management in Developing Countries. MEWREW Occasional Paper No. 9. Water Issues Study Group, School of Oriental and African Studies (SOAS), University of London. Available from Website.
- Turton A R (2000a) Precipitation, people, pipelines and power in Southern Africa: Towards a 'Virtual Water'-based Political Ecology Discourse. In Stott, P. and Sullivan, S. (Eds.) *Political Ecology: Science, Myth and Power*. London: Arnold & New York: Oxford University Press ISBN 0 340-76165 2
- Turton A R (2000b) Water and sustainable development: a southern perspective. Forthcoming in *Encyclopedia of Life Support Systems (EOLSS)*. London: EOLSS Publishers. Available in Draft from Website
- Turton A R (2000c). Water wars in Southern Africa: challenging conventional wisdom. In Solomon, H. and Turton, A.R. (Eds.) *Water Wars: Enduring Myth or Impending Reality?* African Dialogue Monograph Series No. 2. Durban: ACCORD Publishers ISSN 1562-7004
- Turton A R (2000d) Water, development and conflict in Africa. Presentation to the African Dialogue Lecture Series held on 29 August at Pretoria University. Available as a Power Point presentation from the Centre for International Political Studies (CIPS)
- Turton A R, Moodley S, Goldblatt M and Meissner R (2000) An analysis of the role of virtual water in meeting water scarcity: An Applied Research and Capacity Building Project. Johannesburg: Group for Environmental Monitoring (GEM) and IUCN (NETCAB).
- U S Public Health Service (1962) Drinking water standard, US Department of Health Education and Welfare, Washington D C.
- UNEP (1998, 2001), State of the environment, India, United Nation Environmental Program.
- USDI (1985) *Groundwater Manual*, pp. 480.
- Verma C V J (1996) *Manual on Evaporation and its Restriction from Free Water Surface*, Oxford and IBH Publishing Co. Pvt. Ltd., New Delhi.
- Verma C V J et al., (1997) Second international R & D conference: Water and Energy, Vol. 2, CBIP, New Delhi.
- Yadav S R et al., (2005) Rainwater harvesting and groundwater recharge for sustainable development of urban areas, Proceeding of Sustainable Management of Water Resources, Himansu Publication, Udaipur, India, pp. 121-124.

**This page  
intentionally left  
blank**

# **INDEX**

---

## **A**

---

(A.S.R.) Wells 212  
Aquiclude 31  
Aquifers 21, 30, 212  
Aquifuge 31  
Aquitard 31  
Artificial Rain 299  
Artificial Recharge 111, 116, 144, 168, 170, 175, 185, 188

## **B**

---

Bored Wells 36

## **C**

---

Check Dam 122, 205, 211  
Coastal Aquifers 224, 229  
Confined Aquifer 31  
Conservation of Soil Moisture 88

## **D**

---

Desalination 317  
Driven Wells 36  
Droughts 4  
Dug Wells 35

## **E**

---

Escape Weirs 128

Estuaries 239  
Evaporation 41  
Control 79, 85  
Pans 45  
Evapotranspiration 22, 53, 55

## **F**

---

Factors Affecting  
Evaporation 43  
Infiltration 64  
Transpiration 54  
Farm Ponds 152  
Floods 4  
Fresh-Saline Interface 226, 230  
Fresh-Salt Interface 235

## **G**

---

Groundwater 20, 25, 27, 34, 35  
Exploration 37  
Occurrence 25

## **H**

---

Horizontal Wells 36  
Hydrological Cycle 15, 26

## **I**

---

Induced Recharge 140

## 330 Water Management

Infiltration 20, 63  
Infiltrimeters 65  
Injection  
    Recharge 185  
    Wells 147, 162  
Interception 61

### J

---

Jetted Wells 36

### K

---

Kunds 177

### L

---

Leaky Aquifer 31  
Lysimeters 55

### M

---

Measurement of Transpiration/Evapotranspiration 54  
Measuring Evaporation 44  
Methods of Artificial Recharge 112

### N

---

Natural Recharge 111

### P

---

Perched Aquifer 31  
Percolation 122  
    Tanks 197  
Permeability 29  
Phreatic Aquifer 117, 119  
Ponds 106  
Precipitation 19

### R

---

Rain Water Harvesting 77, 181, 184

Rainfall Simulator 68  
Recharge 23  
    Rate 200  
    Techniques 248  
    Through Pits and Shafts 135  
    Through Wells 134  
Recharging 146  
    Well 145  
Recreational Reuse 265  
Reuse of Water 8, 255, 274  
Reverse Osmosis 303, 305, 306  
Roof Water Harvesting (Rwh) 95, 167

### S

---

Salinity Control 249  
Salinity Ingress 246  
Salt Water Intrusion 239, 240, 241, 244, 245  
Sea Water Intrusion 223  
Seawater Barriers 243  
Sewage and Industrial Waste Reuse 266  
Soil Mulches 89  
Source of Groundwater 26  
Spring 35  
Subsurface Dyke 138  
Surface Water 19

### T

---

Tanks 124  
Transition Zone 228  
Transmissibility 29  
Transpiration 53

### U

---

Unconfined Aquifer 31  
Upconing 237

### V

---

Virtual Water 277, 278, 285, 291

### W

---

Wastewater 8, 259

- Reclamation 260
  - Reuse 258
  - Water Availability 2
    - Conservation 10
    - Footprint 277, 288
    - Harvesting 106, 167, 176
    - Mound 199, 207, 215
    - Requirements 3
    - Quality 6, 108, 188, 210
  - Wedge 232, 235
  - Weirs 128, 130
  - Well Clogging 153
  - Wells 35
- 
- Z**
- Zone of Dispersion 227