

about
thalassaemia

AUTHOR DR ANDROULLA ELEFThERIOU

About the author

Dr. Androulla Eleftheriou obtained her graduate and postgraduate degrees from London University, in the fields of Microbiology and Virology. She has been awarded a number of scholarships by the World Health Organisation and the Fulbright Commission, and has held an honorary research post at University College Medical School, UK. Her postdoctoral fellowship was completed at the Centres for Disease Control in Atlanta, GA, USA.

Dr Eleftheriou has been the head of the Virus Reference Centre of the Cyprus Ministry of Health since 1990 and was closely involved in its establishment. She has organised and actively participated in numerous national and international workshops, conferences and projects. She currently serves as a WHO Consultant on issues related to her field of expertise.

Dr Eleftheriou's main interest and research work has been in the area of viral infections in thalassaemia major. Through her research she has had a great deal of contact with physicians and research scientists involved in this area, as well as with patients with thalassaemia in countries across the world. Since 1993, Dr Eleftheriou has collaborated on a voluntary basis with the Thalassaemia International Federation (TIF).

Through its publications, TIF works to ensure that medical information on thalassaemia is easily available. Perhaps more importantly, TIF also provides medical personnel with opportunities to continue learning about thalassaemia, through educational workshops.

In 1997 a new post of TIF Scientific Co-ordinator was created to oversee these tasks. It was unanimously proposed that Dr Eleftheriou be appointed -- a position she accepted wholeheartedly. Dr Eleftheriou has held the post of Scientific Co-ordinator ever since, fulfilling her duties independently of her official government post.

ISBN: 9963-623-40-9

© 2007 Team up Creations Ltd
14 Othonos str, 1016 Nicosia - Cyprus

All rights reserved.

No part of this book may be reproduced, stored in a retrieval system, or transmitted in any form or by any means, electronic, mechanical, photocopying, microfilming, recording, or otherwise, without written permission from TIF and the author.

Printed in Nicosia, Cyprus.

Through her work with TIF, Dr Eleftheriou has carried out numerous projects of both local and international scope in close co-operation with physicians and thalassaemia associations worldwide. She has completed several publications on behalf of TIF, as well as a number in collaboration with WHO and other bodies on a wide range of scientific topics and she is the Chief Editor of TIF's quarterly Magazine.

Acknowledgements

I would like to acknowledge the contribution of Dr. Michael Angastiniotis, Medical Advisor of TIF, who reviewed the book and offered expert guidance and valuable comments and suggestions.

I would also like to acknowledge the contribution of the following medical experts, members of TIF's advisory panel, who reviewed sections of their specializations and provided valuable comments and suggestions:

Prof. John Porter
Department of Haematology
University College London
98 Chenies Mews London WC1E 6HX

Dr. Paul Telfer
Consultant Haematologist
Thalassaemia Centre
Ministry of Health
Nicosia Cyprus

Dr. Malcolm Walker
Consultant Cardiologist
Hatter Institute
Cecil Fleming House
University College London Hospitals
Grafton Way, London WC1E 6AU, UK

Dr. Nicos Scordis
Paediatrician-Endocrinologist
Department of Paediatrics
Arch. Makariou III Hospital
Ministry of Health
Nicosia Cyprus

Prof. Nica Cappellini
Ospedale Maggiore Policlinico
Padiglione Graneli
Via F. Sforza 35
Milano 20122 Italy

The assistance of Dr S. Christou, physician and Mrs A. Kyrri laboratory scientist both members of staff of the Nicosia Thalassaemia Centre, Cyprus Ministry of Health who provided some of the slides and tables and of Dr C. Kokkinos, physician, who prepared the crosswords included in this book is greatly appreciated.

The expert assistance of Dr. Helen Perry, member of the staff of TIF, in the editing and in the preparation of the glossary of this book is greatly appreciated.

Dedication

This book is dedicated to each and every patient with thalassaemia worldwide; those whom I know and have met, those I know but have not yet met, and the hundreds of thousands who live across the world whom I will never have the opportunity to meet. Their determination to live and win have given me the motivation and strength to join in their fight. Their immense courage and endless patience have taught me how to fight without losing.

Table of Contents

	Foreward	vi
	From the author	viii
Chapter 1	Blood and Thalassaemia	1
	Blood - "the river of life"	1
	The role of blood	1
	Composition of blood	3
	Whole blood	3
	Blood types/groups	6
	Diseases of the blood	7
	Thalassaemia major	7
Chapter 2	Genetics and Thalassaemia	9
	Genes	9
	The defect in red blood cells that leads to thalassaemia major	11
	Haemoglobin and iron	12
	Genes controlling globin synthesis	14
	The pathophysiology of thalassaemia	
	Lack of β -chains and excess of α -chains	16
	Diagnosing thalassaemia	18
	Haematological methods commonly used to diagnose thalassaemia major	19
	The treatment of β -thalassaemia major	21
Chapter 3	Blood transfusion therapy	22
	When to begin transfusion therapy	22
	Ensuring safe transfusion therapy	24
	Blood group genotype	24
	What to transfuse	25
	Drawing up a transfusion regime	29
	Assessing the effectiveness of a blood transfusion regime	30
	Treating transfusion reactions	34
Chapter 4	Iron Overload and iron Chelation	38
	Iron in a healthy body	38
	Iron in thalassaemia	38
	How excess iron damages the body	40
	Desferrioxamine (DFO) or Desferal	41
	When to start iron chelation treatment	42
	Other ways of administering DFO	44
	Evaluating the effectiveness of DFO treatment	47
	Using ferritin levels to adjust doses of DFO	48
	Iron content in the urine	50
	Complications associated with DFO and how these may be addressed	50

	Pregnancy	54			
	Compliance with desferrioxamine therapy	54			
	Other drugs for removing iron	55			
	How deferiprone (L1) works	55			
	Efficiency of deferiprone	56			
	Adverse Effects of L1	56			
	Other side effects of deferiprone	57			
	Using Deferiprone in combination with DFO	58			
	New oral drug for removal of excess iron - Deferasirox	59			
Chapter 5	Medical problems associated with thalassaemia and its treatment	62	Chapter 9	Other approaches to treatment	105
	Hypersplenism	62		Foetal haemoglobin inducers	105
	Splenectomy and infections	63		Gene therapy	106
	Heart and endocrine complications	65		Pre-implantation diagnosis with HLA-matching	106
	Heart complications	65	Chapter 10	Psychosocial issues	107
	Endocrine complications	68		The patient	107
Chapter 6	Infections in thalassaemia	76		The parent	107
	Transfusion-associated infections	77		Patients and parents	108
	Hepatitis B virus (HBV) infection	79		Getting information and support	108
	Hepatitis C (HCV)	81		The infant child, the adolescent and the adult patient with thalassaemia major	109
	Other viruses	85	Chapter 11	Some additional information	113
	New pathogens	86		Survival and quality of life	113
	New worries from old pathogens	86	Chapter 12	Epidemiology and prevention of thalassaemia	117
	Blood safety	87		Epidemiology	117
	Safety and availability of blood in the developing world	88		Prevention	118
	Summary of what eventually happens in untreated thalassaemia major	89		The importance of prevention	119
Chapter 7	Thalassaemia intermedia and other thalassaemias	90		How thalassaemia is inherited	119
	Diagnosis	91		About carriers of the thalassaemia trait	120
	Management of thalassaemia intermedia	92		Why it is important to know if you are a carrier	120
	Iron chelation	93		Other abnormal haemoglobins and haemoglobin disorders	121
	Medical problems in thalassaemia intermedia	94		a-thalassaemia	122
	Thalassaemias associated with "abnormal haemoglobin" or structural haemoglobin variants	96		Finding out whether you are a carrier	123
	Compound abnormal haemoglobins with β -thalassaemia	97		Who should have a blood test	125
	a-thalassaemia	97		Consanguinity	126
Chapter 8	Therapeutic regimes - established and future approaches	99		The choices available for an "at-risk" couple	126
	Bone marrow transplantation (BMT)	99		Testing a foetus for thalassaemia	127
	What is a bone marrow transplant?	99		Glossary	131
	What are the risks?	100		Index	142
	How can the risks be minimised?	100	Useful info	Diet and Thalassaemia	145
	Other approaches to bone marrow transplantation with an exact match (related)	102		T2* measures iron content in heart	153
	Cord blood transplantation	103		Flow charts	154
	Conclusion	103		Abbreviations, units and measures used in the book	160
				Crosswords - Brain teasers	161
				Useful Websites	171
				Useful Correspondence information	173

Foreword

The Thalassaemia International Federation (TIF) was established in 1986 with the objective of promoting policies aimed at the prevention and appropriate clinical care of thalassaemia around the world.

The establishment and enlargement of national thalassaemia associations and the development of an educational programme for providing specialists working in the field of thalassaemia with continuous training have been amongst the most important means by which TIF aims to achieve these goals. In this context, TIF has placed considerable emphasis on strengthening national patient/parent groups, as these constitute the most important form of pressure on health authorities for the promotion of national policies for the effective prevention and appropriate medical care of thalassaemia. Thalassaemia associations also undoubtedly play a key role in public awareness campaigns, a very important part of any programme aimed at controlling thalassaemia.

TIF has also emphasised the importance of establishing a productive educational programme, organising national, regional and international workshops, seminars and conferences and publishing a wide range of material translated into many languages - from basic information for patients, parents and the general public, covering the disease, its treatment and prevention, to more specialised scientific texts for physicians involved in the clinical management of thalassaemia.

This book will greatly contribute to efforts aimed at providing patients and parents with an invaluable source of up-to-date, accurate information presented in a simple, partly illustrative manner, covering all aspects of thalassaemia, from the cause and nature of the disease to its treatment, prevention, social and emotional dimensions.

TIF is extremely grateful to its Scientific Coordinator, Dr Androulla Eleftheriou, for taking on the challenging task of writing this book. It is hoped - indeed,

I am confident - that this new and thoroughly updated work will help give patients and parents the hope and continued support they need to face and fight thalassaemia.

Panos Englezos
TIF Chairman

From the author

Dear friends,

When the Chairman of the Board of Thalassaemia International Federation asked me to consider writing a book about thalassaemia focusing on the needs of patients and parents, I hesitated at what seemed a daunting task -- A highly successful and very popular such publication had been written some years ago by pioneer scientists who excelled in the field of thalassaemia. Since then however, the advances made in all aspects related to the control of thalassaemia have been numerous and significant.

I decided, to take on the challenge and write this book to include all these new developments but also for a number of reasons. First, I am deeply involved with TIF, and deeply committed to promoting its objectives. More importantly still, I have great love for the world thalassaemia family, of which I feel a part.

I have tried very hard to produce a book, primarily for patients and parents, that provides accurate and up-to-date information on thalassaemia -- about the disease, its treatment and prevention. Every effort has also been made to present this information in clear and simple language. This has not been always feasible, particularly in chapters where I was concerned that oversimplification of the language might have jeopardised the precise meaning. However, it is hoped that the rich glossary provided at the end of the book, as well as the many illustrations and graphics, will help the reader reach a more complete understanding of the text where it was not possible to simplify the language.

The reader will notice that more emphasis has been given to particular chapters. The decision to provide more detail in some sections was taken where I felt the chapter(s) covered parts of the treatment regimen critical to the patient for his/her survival and quality of life. On other occasions, such as in the case of the cardiology section, the considerable medical and technical terminology involved prohibited me from expanding more.

All information contained has been taken from published reports and reviews and TIF can provide the reader upon request with relevant publication(s) on any subject or issue discussed in this book.

This book, together with the game "Play and learn about thalassaemia" and a cartoon book "About thalassaemia" still in preparation but following soon will assist patients of all ages and their parents to become familiar with thalassaemia, and its treatment.

It is also hoped that these publications will play a useful role in familiarising patients and parents with many of the medical terms they may come across when interacting with medical staff or reading about thalassaemia in more scientifically-oriented books and journals.

Patients with chronic diseases in countries with established policies on raising public awareness and for the control of thalassaemia and other genetic disorders are often well educated about their disease, and are continually seeking information and updates on new developments. However, patients in developing countries often need more support in acquiring reliable and up-to-date information -- information that is crucial both to help them in their own, individual fight against the disease, and the broader fight to ensure that governments put in place policies for appropriate treatment.

Finally, this book includes a small chapter on how to prevent the birth of a child affected by thalassaemia -- an important subject both from a public health perspective, as well as in terms of ensuring the quality of treatment provided to existing patients. Additional births of affected children seriously limit the resources available for providing appropriate clinical care for existing patients.



Dr Androulla Eleftheriou

Chapter 1

Blood and Thalassaemia

The thalassaemias are a group of disorders that prevent the body from producing a sufficient quantity of high quality blood. As we will see, the human body relies on the blood to survive, so it is important to understand any problem that affects the blood and how the body copes with it.

Blood - "the river of life"

Blood is a vital fluid that brings nourishment to the body's organs and tissues and carries away waste substances. A healthy adult has about 5 to 6 litres of blood - roughly 7-8% of total body weight.

Blood is moved around the body by the heart, which pumps blood through a network of "pipes" called blood vessels. There are three different types of blood vessel: arteries, veins and capillaries (see 1a, 1b), each of a different size and function. Together, these vessels are known as the circulatory system (see 1a).

The role of blood

Blood performs many important functions:

- (i) Transports oxygen: The body relies on blood to bring it the essential nutrients it needs to function, and to carry away the poisonous waste products it needs to get rid of. For example, all cells and living organisms need oxygen - a gas found in the air we breathe - to survive and function. The blood picks up oxygen from the lungs carrying it to different parts of the body.
- (ii) Picks up carbon dioxide, another gas that is a waste product formed by cells, carrying it back to the lungs to be released into the outside air. The blood also collects other waste products, such as urea and uric acid, carrying them to the kidneys and liver. Eventually,

1a red = oxygenated blood
blue = deoxygenated blood

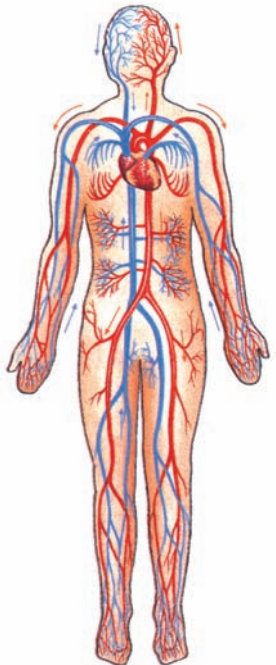

1b

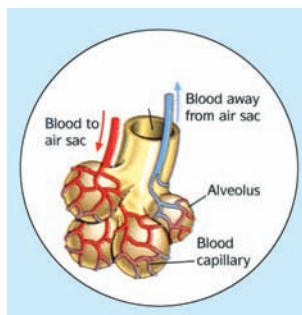

1c

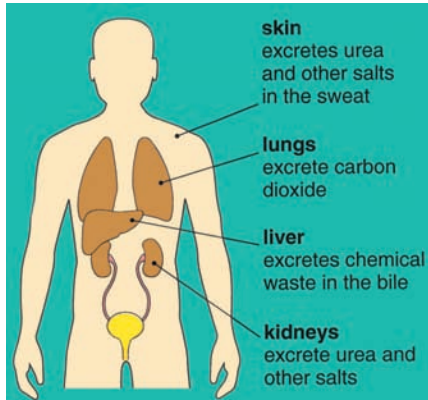

waste products are removed from the blood in urine and stools (see 1c). The blood also

- (iii) transports special chemicals called hormones, which regulate the function of important systems of the body, such as the endocrine, sexual and reproductive systems
- (iv) delivers nutrients to different parts of the body -- proteins, fats and carbohydrates, produced from food broken down by the digestive system (see 1d, 1e)
- (v) helps the body fight infection and disease through cells that form part of its defence system, the immune system.

1e digestive system

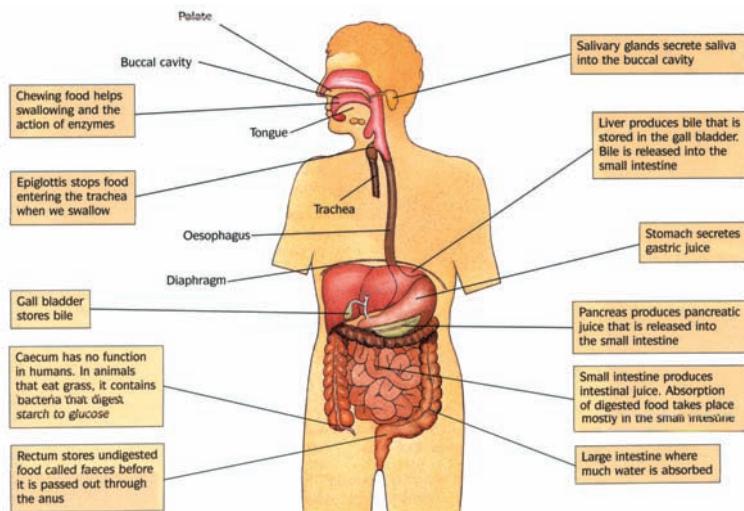

1d exchanges between the blood and tissue fluid across the capillary walls

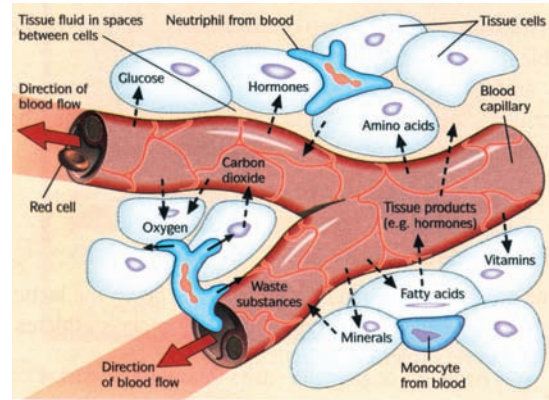

Composition of blood

Blood is produced in the bone marrow (see 1f), a tissue found in the middle (central cavity) of bones. In infants, blood cells are made in several body tissues. In adults, blood cells are only produced in the marrow of the skull, spine, ribs and pelvis.

Whole blood

Whole blood is made up of two parts: (i) non-cellular -- the part that contains no cells -- and (ii) cellular -- the part that contains cells. Our bodies are made up of trillions of microscopic units - tiny building blocks called cells. Cells are far too small to be seen by the naked eye. In most tissues, they are stuck together. But in blood, cells float around. Each cell has three major parts or compartments: the centre or nucleus, the substance around the nucleus known as the cytoplasm, and the structure surrounding the cell -- the cell membrane (see 1g). Numerous other smaller structures are found within each of these major cell compartments, each with a specific function. However, a large part of every cell is water, along with proteins, fats, carbohydrates, nucleic acids, dissolved molecules and inorganic ions. Proteins are the 'workhorses' of our cells, and there are 100,000 different types of proteins in our body. Some of the functions of proteins in cells include:

- Providing the building blocks for most cellular structures
- Acting as enzymes - catalysts for the chemical reactions that make life possible
- Controlling communications between cell surfaces
- Controlling the expression of genes
- Replicating genetic material

(i) The non-cellular part of blood is a yellowish liquid called plasma, which makes up 55% of whole blood. Plasma is made up of water and salts, as well as important proteins that it carries around the body, such as:

1g cell

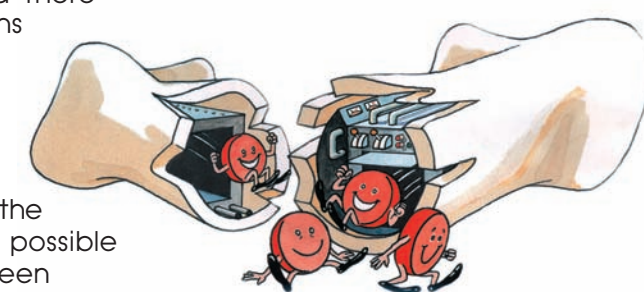
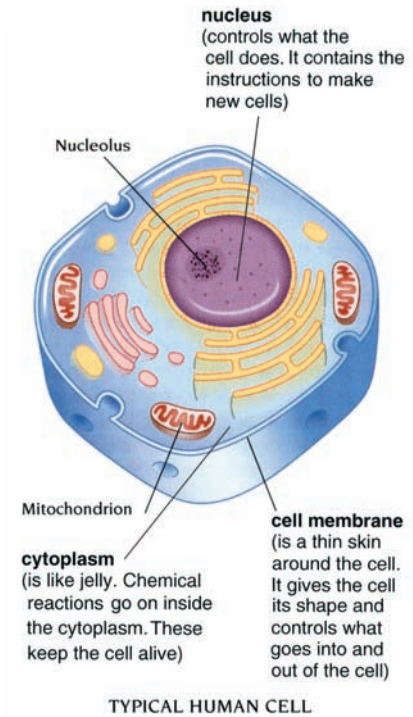

1f bone marrow

1h composition of blood

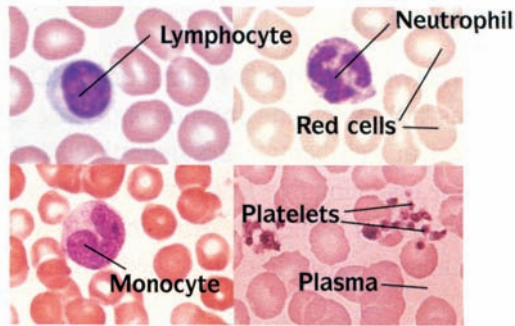

- albumin, the main protein in blood
- globulins, including gamma globulin, which is composed of tens of thousands of antibodies that help the body fight infections and diseases
- fibrinogen, which helps the blood to clot, limiting the flow of blood out of the body after an injury

(ii) The cellular part of blood is made up of three different types of cells: red blood cells or erythrocytes, white blood cells or leukocytes, and platelets or thrombocytes (see 1h).

Red blood cells or erythrocytes (RBCs) The body contains around 4,500,000-5,000,000/mm³ of RBCs -- almost 45% of total blood volume. RBCs also have the longest average lifespan of any of the cellular elements of blood -- 100-120 days.

The primary function of RBCs is to carry oxygen around the body, binding the oxygen to a compound called haemoglobin, which it then delivers to each cell in the body. Red blood cells contain many molecules of haemoglobin - as many as 300 million - which give the blood its red colour. In fact, RBCs are so packed with haemoglobin that they do not contain some of the parts found in other cells, such as a nucleus (see 1h).

The membrane or outer layer of a red blood cell is very flexible, like a soap bubble. This allows the cell to bend in many directions without breaking, particularly when it passes through the tiniest blood vessels (the capillaries) to deliver oxygen wherever it is needed.

RBCs also contain substantial amounts of an enzyme known as carbonic anhydrase, which plays an important part in transporting carbon dioxide from the tissues to the lungs.

White blood cells or leucocytes (see 1h), make up just 1% of blood. They play a vital role, working as the body's first line of defence against invading infectious agents such as bacteria, viruses, fungi and parasites. White blood cells are a diverse group of cell types, each contributing in a different way to fighting and preventing

infection and tissue damage. They are usually classified according to their morphological characteristics:

- Granulocytes or polymorphonuclear cells, so called because of their granular appearance and lobed nuclei. These are subdivided according to the colour they assume upon staining in the laboratory:
 - neutrophils (see 1i) (72% of white cells), which are blue on staining
 - eosinophils (see 1j) (1.5% of white cells), which are red on staining
 - basophils (see 1k) (0.5% of white cells), which are purple on staining
- Other white cells are:
 - monocytes (see 1l) (4% of white cells)
 - lymphocytes (24% of white cells) (see 1h)

White blood cells are bigger than red blood cells but they are much fewer in number -- about 7,000/mm³ of blood -- and their lifespan is much shorter - just 18-36 hours.

Platelets play a single, crucial role in the blood- they begin the process of coagulation (forming the blood into a clot) to prevent the body losing blood through a damaged blood vessel. Platelets are the smallest blood cells in the body (see 1h). There are around 200,000 platelets/mm³ blood, with a lifespan of 97-100 days.

Both white blood cells and platelets (but not red blood cells) contain a central part called the nucleus and an outer margin called the cytoplasm.

The three types of blood cells - red blood cells, white blood cells and platelets -- all develop from the same starter (or precursor) cell, known as a haemopoietic stem cell. Starter cells multiply extremely quickly. In just four weeks, 10 starter cells can multiply to make 30 trillion red blood cells, 30 billion white blood cells and 1.2 trillion platelets -- enough to replace every blood cell in the body.

1i neutrophil

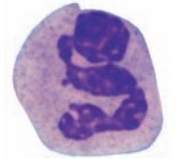

1j eosinophil

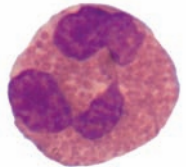

1k basophil

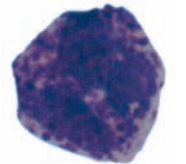

1l monocyte



From Sysmex poster

1m what platelets do

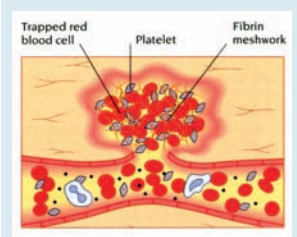

- 1 The skin is cut and blood starts leaking out of the body.
- 2 There is a protein in the blood called **fibrinogen**. When **platelets** come in contact with it they turn the fibrinogen into threads of **fibrin**. The threads make a net over the cut.
- 3 Red blood cells get caught in the net and make a blood clot which seals the cut
- 4 The clot dries to make a scab. New skin grows under the scab.

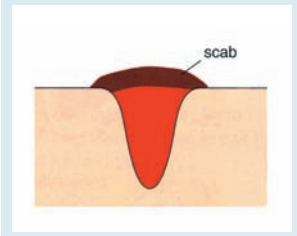

Blood types/groups

There are four major blood groups: A, B, AB and O, identified by the type of protein - also known as marker or antigen - carried on the surface of the red blood cells. Each person's blood falls into one of these four main categories of A, B, AB or O, i.e. each person has red blood cells of just one of these groups.

Blood group A - red blood cells carry a marker A on their surface.

Blood group B - red blood cells carry a marker B on their surface.

Blood group AB - red blood cells carry both A and B markers on their surface.

Blood group O - red blood cells carry neither A nor B markers on their surface.

Red blood cells can also contain another antigen, unrelated to blood group - the Rhesus (Rh) antigen. Blood containing the Rh marker is described as Rh positive, while blood without the Rh marker is described as Rh negative.

More than 20 other red blood cell types have been discovered, but the above are the most important and most commonly known.

There are several reasons why a person may need to know his/her blood type. The most important is where an individual needs to receive blood from another person, i.e. when a blood transfusion is needed (see 1w). In a blood transfusion, the blood of the donor (the individual who gives blood) and the blood of the recipient (the individual who receives blood) must be carefully matched so that the recipient's body does not reject the donor's blood. The process of matching a donor's blood group and Rhesus antigen with a recipient usually takes place in the laboratory of a blood bank, and is referred to as cross matching or compatibility testing. If the blood group and Rhesus factor are not identical, the recipient's body will identify the donated blood as an intruder and will try to destroy it. The body's effort to fight the 'foreign', unmatched blood can result in severe illness and even

death if not promptly diagnosed and treated.

Diseases of the blood

Many diseases are caused by abnormalities in the blood. These abnormalities are categorised according to the part of the blood affected; there are diseases of the red blood cells, the white blood cells or coagulation diseases.

Red blood cell diseases include thalassaemia. One of the most common diseases of the red blood cells is anaemia - a disease in which the body has an abnormally low number of red blood cells or low level of haemoglobin. The common symptom of anaemia is fatigue (tiredness), because the blood fails to carry and deliver enough oxygen around the body. The most common type of anaemia is iron deficiency anaemia, where the bone marrow does not produce a sufficient number of red blood cells. Patients are often cured of this type of anaemia by simply taking iron supplements.

Other types of anaemia, however, are more serious. In haemolytic anaemias, for example, the body destroys red blood cells at a rapid rate. In thalassaemia major, red blood cells are destroyed almost as soon as they are produced and the bone marrow cannot produce a sufficient number to replace them. These diseases are inherited - passed from parents to their children - and are very severe. For many years, it was thought that they were untreatable and that patients would inevitably die at an early age. We now know, however, that with proper treatment, patients can lead full and fulfilling lives.

Thalassaemia major

Thalassaemia major, also known as Mediterranean Anaemia or Cooley's Anemia, was once thought to be limited to the region around the Mediterranean Sea, hence the name Mediterranean Anaemia or thalassaemia (thalassa-anaemia) -- the latter deriving from the Greek word "thalassa", meaning sea i.e. the anaemia occurring in countries around the sea - the Mediterranean sea. The disease is also called Cooley's Anemia after Thomas Cooley, the American paediatrician who, along with Dr Perl Lee,

1w

Group	Can donate to	Can receive from
A	A and AB	A and O
B	B and AB	B and O
AB	AB	all groups
O	all groups	O



Chapter 2

first described and reported some of the characteristic clinical features associated with the disease in 1927, following studies of patients of Italian origin.

Thalassaemia major, the most severe of the thalassaemias, is the main subject of this book. The disease is common in temperate regions of the world. However, the migration of people around the globe has introduced thalassaemia to many parts of the world where it was not previously common. In particular northern countries like the UK, the US, Canada and Germany now have a significant number of cases due to immigration from southern Europe and Asia.

Genetics and Thalassaemia

Thalassaemia is an inherited genetic disease, i.e, passed from parents to children through the genes. It is not transmitted through blood, air or water, or through physical or sexual contact with a patient, nor can it be caused by poor nutrition or medical conditions.

Genes

Genes are the unique blueprints for an individual organism, providing all the biological information needed for controlling growth and development throughout its life - the biological units of inheritance. The key part of each gene is a chemical substance called deoxyribonucleic acid or DNA.

DNA (see 2a) - DNA is a ladder-like structure, with two parallel structures supporting a series of rungs. Each rung is made of two chemicals, called bases, paired together. Each base is represented by a different letter: C, G, A, T - C for cytosine, G for guanine, A for adenine, T for thymine. These four bases always pair up in a restricted fashion:

A with T and C with G (see 2a). The order in which bases are laid along the 'ladder' provides an organism's genetic code. Taken together, an organism's DNA is referred to as the 'genome' (see 2b). The human genome contains thousands of genes.

DNA provides instructions for building all the molecules responsible for an organism's biological functions, such as proteins. The process of making a molecule from a gene involves biological machinery in the cell 'reading' the information carried by a gene.

That information is copied into a molecule similar to DNA called RNA, or ribonucleic acid. Like DNA, RNA contains the bases guanine, adenine and thymine, (G, A and T) but instead of cytosine (C), the fourth base in RNA is uracil (U). RNA also differs from DNA in that it is a single- rather than double-stranded ladder-like structure. The function of RNA is to act as a messenger (mRNA) to carry information from the DNA to the cell's biological machinery responsible for making biological products such as proteins.

2a DNA

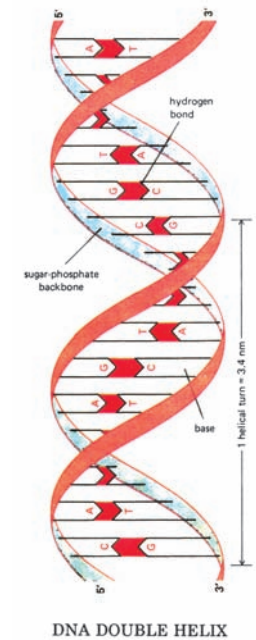

DNA DOUBLE HELIX

2a DNA



2b genome

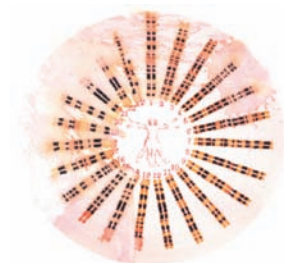

2c chromosomes



A great number of genes are needed to carry out the many and complicated biological functions of the human organism. These genes are kept linked together in the cell on extremely long pieces of DNA, called chromosomes. Each human cell (except sperm/egg cells) has two copies of each chromosome, one from the mother and one from the father.

Different kinds of organisms have different numbers of chromosomes. Humans have 23 pairs of chromosomes, or 46 in all (see 2c). Twenty-two pairs, or a total of 44, are the same in both males and females and are called autosomes, while one pair, the two sex chromosomes, decide the gender. Every human being has one chromosome in each pair from their mother and one from their father.

After years of research, it has been possible to identify numerous genes that when affected are responsible for different illnesses, called genetic disorders.

Genetic disorders can be separated into four categories:

1. Chromosome abnormalities - these result when entire chromosomes or large segments are missing, duplicated or altered.
2. Single-gene disorders - these are caused when a change or mutation at the level of the gene causes changes or prevents the synthesis of the product of a single gene.
3. Multifactorial - this disorder results from changes (mutations) in multiple genes, often coupled with environmental causes - i.e. several factors must come together before a pathological condition is produced.
4. Mitochondrial - disorders caused by changes (mutations) in non-chromosomal DNA located within small structures in the cytoplasm of the cell, known as the mitochondria (see 2d), the cell's energy station.

Thalassaemia is what's known as a single-gene disorder'. Single-gene disorders are passed from parents to child through one of four basic patterns, first described by Gregor Mendel, a monk, in 1865. These are:

- (i) autosomal dominant

- (ii) autosomal recessive
- (iii) x-linked dominant and
- (iv) x-linked recessive

These are terms used in genetics to describe whether the clinical outcome (phenotype) resulting from the gene abnormality (genotype) can be inherited from (i) just one parent (autosomal dominant), or from (ii) the contribution of both parents (autosomal recessive), or only through (iii) an abnormality in the sex-determining chromosome from one parent (x-linked dominant), or as a result of (iv) the sex-deciding chromosomes of both parents (x-linked recessive).

Thalassaemia is a single-gene disorder that is passed from parents to child by what is called an autosomal recessive pattern of inheritance.

An 'autosomal' disease can affect males and females alike since the abnormality is on one of the autosomes - i.e. not the chromosomes responsible for determining the sex of a child.

'Recessive' means that the child needs to inherit the defective gene from both the father and the mother in order to develop the severe clinical condition of thalassaemia major.

Individuals who inherit a defective gene from both their mother and father are described as homozygotes -- in the case of β -thalassaemia, they are described as patients with homozygous β -thalassaemia. They may also be referred to as having thalassaemia major, Mediterranean Anaemia or Cooley's Anemia. These patients will develop all the symptoms associated with the disease.

Those who inherit a normal gene from one parent and a defective gene from the other are referred to as heterozygotes, or in the case of β -thalassaemia, as heterozygous for β -thalassaemia. Other terms used include being a carrier of the thalassaemia trait or an individual with thalassaemia minor. Such individuals will not develop symptoms of the disease, however, they could pass the defective gene on to their children.

The defect in red blood cells that leads to thalassaemia major

As described in Chapter 1, thalassaemia is an inherited genetic disorder of the blood; more specifically, it is a disorder

2d mitochondrion (respiration)

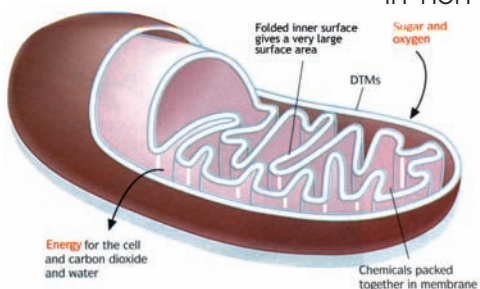

der that results from abnormalities in the synthesis of the haemoglobin molecule contained in red blood cells.

Haemoglobin and iron

Haemoglobin (see 2e) is a specialised type of compound molecule - a protein - found in red blood cells, the main function of which is to transport oxygen to wherever it is needed in the body.

Each red blood cell contains 300 million molecules of haemoglobin.

A molecule of haemoglobin has two parts:

- i) A protein called globin, made up of four protein chains arranged in matching pairs (see 2e+f). There are several types of chains - the α -chains, α_2 , and the non- α chains, β_2 , γ_2 , δ_2 , ζ_2 , ϵ_2 , matched in pairs as $\alpha_2\gamma_2$, $\alpha_2\beta_2$, $\alpha_2\delta_2$, $\alpha_2\zeta_2$ and $\alpha_2\epsilon_2$.
- ii) Haem-iron - a ring structure synthesised in the cell's mitochondrion and cytosol. An iron molecule contained in the haem-iron enables the transport of oxygen around the body. This is because iron easily binds with and loses oxygen, making it the perfect means of delivering oxygen to the tissues and cells.

Normal adults have 4g of iron in their body, 75% of which - i.e. about 3g - is used to synthesise haemoglobin.

The production and synthesis of haemoglobin (Hb) is controlled by a number of genes: the α -genes on chromosome 16 and the β -, γ -, and δ -genes on chromosome 11. There are four genes that code for α -chains and two

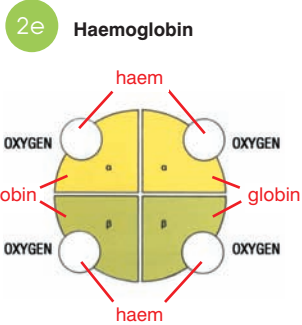

genes that code for β -chains (see 2g). Irrespective of the number of genes responsible for controlling the synthesis of α - and β -chains, these two chains are produced in exactly equal amounts.

Different types of haemoglobin result from matching the different chains and different types of haemoglobin produced at each stage of life (see 2h), as shown below:

" α " chain	"non- α " chain	Hb	Name of haemoglobin	Stage of life produced
ζ	ϵ	$\zeta_2\epsilon_2$	Gower 1	First eight weeks of gestation
α	ϵ	$\alpha_2\epsilon_2$	Gower 2	First eight weeks of gestation
ζ	γ	$\zeta_2\gamma_2$	Hb Portland	First weeks of gestation and in hydrops foetalis due to homozygous α -thalassaemia
α	γ	$\alpha_2\gamma_2$	HbF	Dominant Hb from 6 weeks gestation to term. <1% in normal adult
α	β	$\alpha_2\beta_2$	HbA	Up to 10% in normal foetus from at least 8 weeks gestation. Dominant Hb in normal adult
α	δ	$\alpha_2\delta_2$	HbA ₂	Minor Hb produced at 1/30 th of level of HbA and associated with it. <3% in normal adult.

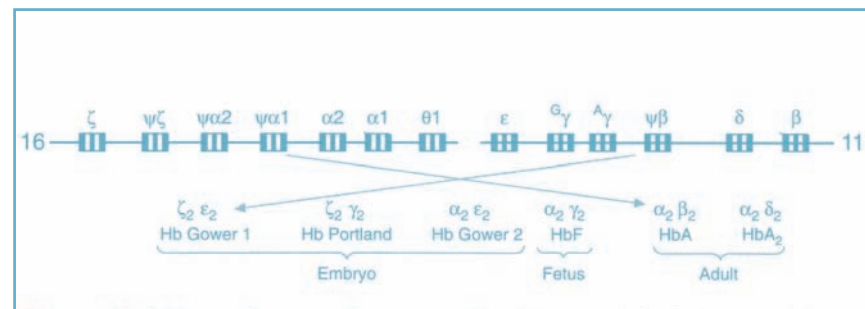

2g The α - and β - globin gene clusters on chromosomes 16 and 11, respectively.

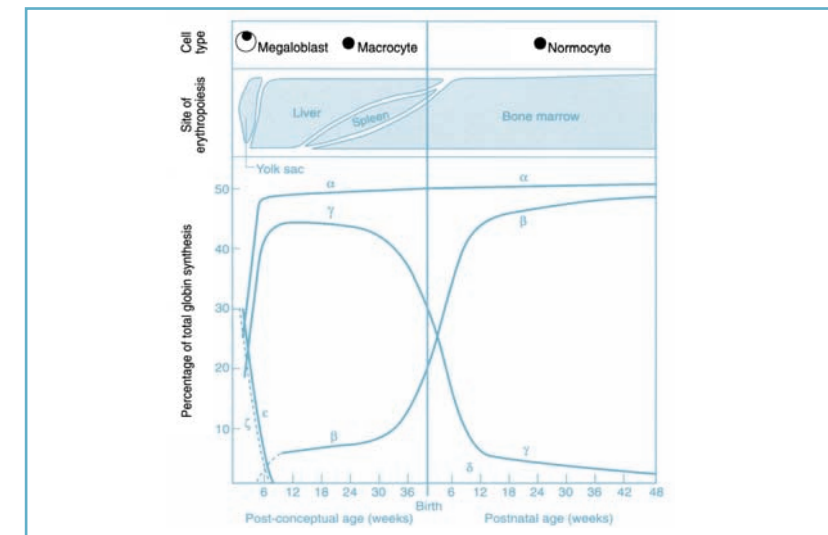

2h The sites of erythropoiesis during development and the different globins produced at each stage

From TIF's "Guidelines for the Clinical management of Thalassaemia"

Genes controlling globin synthesis

The precise defect that leads to β -thalassaemia major lies in the gene controlling the production of β -chains in the globin part of haemoglobin.

As a result of this genetic defect, either no β -chains at all are produced, or a very small amount, leaving the red blood cells with just one type of chain, the α -chains. This imbalance prevents the production of normal haemoglobin, which requires the presence of both α - and β -chains to function properly. As a result, the effective production of red cells, a process known as erythropoiesis (from the Greek erythra, meaning red cells and poiesis, meaning production), is severely affected.

The defect to the gene responsible for the production of β -chains of haemoglobin is caused, as previously mentioned, by single changes in a base pair (point mutations) or because pieces of the gene are missing (deletions). More than different 200 mutations that can affect the normal functioning of the β -globin gene have been identified. Depending on the type of mutation, globin synthesis may be affected to a greater or lesser degree, leading to a mild or more severe form of thalassaemia. Certain mutations have a moderate (β^{++}) to significant (β^+) effect on the production of β -chains, while others (β^0) virtually end production altogether.

Thus people who inherit the β^+ gene from both parents are likely to develop a mild form of thalassaemia. In contrast, those who inherit the β^0 gene from both parents will lack β -globin almost entirely and will most probably develop the most severe form of thalassaemia. Where mixed genes are inherited, however, it is not easy to predict the resulting phenotype - i.e. $\beta^+\beta^{++}$ or $\beta^+\beta^0$ or $\beta^{++}\beta^0$.

With β -thalassaemia, examples of the possibilities are:

β^0/β^0 -- thalassaemia major
 β^+/β^+ -- thalassaemia major
 β^{++}/β^{++} -- thalassaemia intermedia (milder form of the disease)
 β^+/β^{++} -- thalassaemia major / thalassaemia intermedia

Genotype/phenotype

The finding that specific genetic mutations (genotypes) can be correlated with the clinical severity of a disease

(phenotype), as described above, is very important. Various combinations of the three different genes (β^{++} , β^+ and β^0) associated with thalassaemia result in different degrees of severity in the disease. At the same time, different countries have their own characteristic gene combinations and most frequent mutations.

Examples of severe (o), less severe (+) and mild mutations (++) are shown below:

β^{++} mutations	β^+ mutations	β^0 mutations
-101, -87, -88, -28	IVS1-110	IVS1-1
IVS1-106	IVS11-745	IVS11-1
	IVS1-5	IVS1-[-25]
		C39

A number of other genetic conditions may also reduce the severity of the disease, such as:

- (i) Decreased synthesis of α -chains. Some patients with thalassaemia major may, for example, inherit a mutation that decreases the synthesis of α -chains, in addition to the mutation decreasing the synthesis of β -chains. In such cases, the imbalance between α - and β -chains is reduced and the disease takes a milder form.
- (ii) Increased synthesis of γ -chains. Normal adult blood contains about 1% foetal haemoglobin or HbF, made up of one pair of α -chains and one pair of γ -chains ($\alpha_2\gamma_2$). In thalassaemia patients, the production of γ -chains is increased as the body tries to compensate for the lack of HbA production by increasing production of HbF. This increase is not, however, sufficient to replace the function of the missing HbA. However, some patients with thalassaemia may also inherit a condition known as Hereditary Persistence of Foetal Haemoglobin or HFPFH, in which levels of HbF are found at even higher levels, and persist throughout adult life. Patients may also inherit mutations associated with the stimulation of the γ -globin genes (e.g. γ Xmn polymorphism) or other conditions such as $\delta\beta$ -thalassaemia, which can also result in an increase in the synthesis of foetal haemoglobin in adults (by 5-20%) and thereby reduce the severity of thalassaemia, by reducing the imbalance of the globin chains.

The pathophysiology of thalassaemia Lack of β -chains and excess of α -chains

During pregnancy, the blood of the foetus contains a special kind of haemoglobin called foetal haemoglobin (HbF), made up, as previously mentioned, of one pair of α -chains and one pair of γ -chains ($\alpha_2\gamma_2$). This haemoglobin carries out the same function of transporting oxygen around the body that normal haemoglobin performs in older children and adults. After birth, foetal haemoglobin normally continues to function for the first six months of life, when it is gradually replaced with adult haemoglobin (HbA), made up of two α -chains and two β -chains ($\alpha_2\beta_2$).

In thalassaemia major, however, no β -chains are produced - or only a very small amount - preventing the synthesis of normal adult haemoglobin and severely damaging the red blood cells' capacity to transport oxygen. The child's body reacts by continuing to make foetal haemoglobin. However, it cannot make a sufficient quantity to meet the needs of the child's growing body and replace the oxygen transporting functions of adult haemoglobin $\alpha_2\beta_2$.

The low level - or absence - of β -chains also has other negative effects. As the body continues to produce normal amounts of α -chains but insufficient β -chains for them to pair up with, the excess α -chains begin to accumulate. These excess α -chains interfere with the body's production of red blood cells, reducing production by up to 95%. With few mature red blood cells in the blood, the body develops severe anaemia.

In addition, the excess α -chains are deposited in those mature red blood cells circulating in the system, damaging their membranes, leading to their destruction, and adding to the severity of the anaemia. The process by which red cells are broken down is known as haemolysis (from the Greek haem, meaning blood, and lysis, meaning to break apart). Haemolysis causes higher than normal levels of bilirubin, a yellow chemical substance that is a product of the metabolism of haemoglobin, and which is released by red blood cells damaged in the process of haemolysis. The release of higher levels of bilirubin gives the eyes and skin of patients with thalassaemia major a yellowish colour (sometimes referred to as 'icteric').

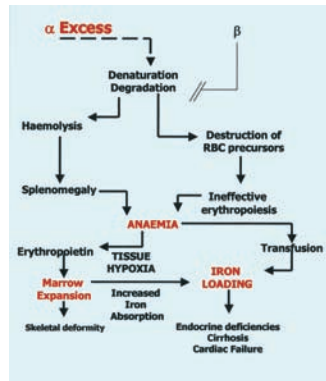

As a result of the severe anaemia caused by thalassaemia major, patients are pale, fatigued and suffer tachycardia - an abnormally rapid heartbeat - because the heart tries to compensate for the reduced capacity of the blood to carry oxygen by beating faster. This also causes the heart to enlarge. Patients have slower rates of physical growth and it becomes difficult to carry out normal physical activities. They suffer persistent anaemia that does not respond to treatment. Children become weak, lethargic (sleepy) and irritable and cry more than usual.

The severe anaemia also triggers several defence mechanisms in the body, the most significant of which is the expansion (or hyperactivity) of the bone marrow. As previously described, red blood cells are produced in the bone marrow. In an effort to counter the low level of red blood cells in the system, the bone marrow expands to about 30 times its normal size to produce more cells. This expansion of the bone marrow in turn forces the bones to expand, producing deformities of the skull, protrusions of the upper teeth, and distortions of the ribs and vertebrae. Bones become thinner (osteopenia) and more fragile, often leading to fractures.

The red blood cells are filtered in the spleen - the organ normally responsible for breaking down red blood cells at the end of their lifecycle. However, in patients with thalassaemia the spleen must cope with a huge number of red blood cells, produced by a hyperactive bone marrow. As a result, the spleen itself becomes overactive and begins to enlarge, in an effort to break down the extra red blood cells - a condition known as hypersplenism. In addition to destroying older red blood cells, the overactive spleen also destroys some white blood cells, platelets and young red blood cells, further worsening the anaemia. The red blood cells circulating in the system of patients with thalassaemia have an abnormal shape because they lack normal Hb molecules, and often become trapped in the spleen - adding to the size of the spleen. Finally, the spleen may also attempt to counteract the body's anaemia by producing red blood cells itself (extramedullary erythropoiesis), further contributing to the spleen's enlargement.

So an excess of α -chains and the imbalance in the number of α - vs β -chains is the main cause of the pathophysiology of thalassaemia major - the functional changes that accompany the disease.

Excess α Globin Chains

- Major cause of anemia
- Precipitate in early nucleated erythroid progenitors in marrow
- Lead to ineffective erythropoiesis
- Precipitate in mature red cells
- Lead to hemolysis
- Undergo proteolysis

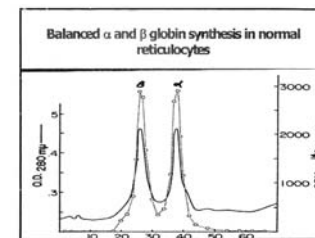

— absorbance
○-○-○ radioactivity

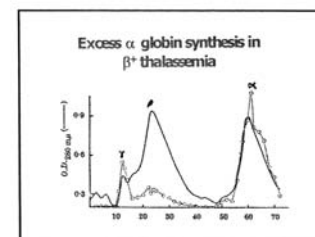

— absorbance
○-○-○ radioactivity

The body attempts to compensate for the severe anaemia by absorbing more iron from food passing through the gut (gastrointestinal tract). However this only makes the situation worse: patients with thalassaemia suffer from anaemia because their bodies are inefficient producers of red blood cells, not because of a shortage of iron. By absorbing more iron, the body exposes itself to new dangers - iron overload.

Diagnosing thalassaemia

A child born with thalassaemia will show no visible signs of the disease. Even laboratory tests may fail to diagnose thalassaemia, particularly if the parents have not been tested, no prenatal tests were carried out, and there is no other affected child in the family. The reason thalassaemia is so hard to diagnose at this early stage is that the presence of sufficient amounts of foetal haemoglobin (HbF) ensures a balance in the number of globin chains - α and γ - that make up HbF, protecting the young child from the ineffective process of red blood cell production described earlier.

It is possible to diagnose thalassaemia at this very early age by means of molecular techniques that identify mutations the child has inherited from each parent. However, this test is only likely to be carried out where a specific suspicion arises - for example, where parents discover after a baby is born that they are carriers. Unfortunately, even where newborn screening programmes are well established, the diagnostic tests involved in identifying thalassaemia major are inconclusive at such an early stage. However, screening can be of use in diagnosing the presence of a variant such as HbE or HbS.

In most cases, thalassaemia major can be diagnosed before the age of 2. Thalassaemia intermedia can however remain undiagnosed for longer periods. The table below shows the results of work done by some investigators on this matter.

Age at presentation of infants with thalassaemia major (TM) or thalassaemia intermedia (TI) (from Modell and Berdoukas 1984)

Age (year)	TM	TI
<1	75-62%	4-11%
1-2	35-29%	11-30%
>2	11-9%	22-59%

Haematological methods commonly used to diagnose thalassaemia major

- (i) Haematological indices. These haematological parameters are measured by electronic equipment - a red cell counter - used to assess the size and volume of red blood cells and the amount of haemoglobin contained in them. Thalassaemia is diagnosed where the size and volume of red blood cells and the concentration of haemoglobin inside them are significantly reduced, with haemoglobin levels of between 2-6g/dl. Some haematological indices most commonly found in patients with thalassaemia are shown below:

	mean	range
Hb g/dl	6.8	3.9-9.3
MCH pg	20.9	15-26
MCV FL	65.8	57-75
MCHC g/dl	30.9	26-34

The number of white blood cells may appear raised due to the presence of a large number of immature (nucleated) red blood cells, which the cell counter may mistakenly identify as white blood cells. However, this miscounting is easily clarified by further laboratory investigations.

- (ii) Blood film and RBC morphology. Observed under a microscope, the red blood cells appear paler (see 2k) (hypochronic) and smaller (microcytic) than normal and - very importantly - the majority have abnormal shapes: anisocytosis, poikilocytosis.

2k

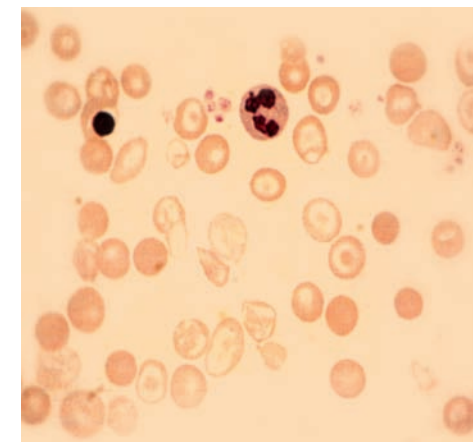

- (iii) Haemoglobin electrophoresis. This is a process that separates the different proteins that make up a haemoglobin molecule - i.e. HbA, HbA2, and HbF. A diagnosis of thalassaemia is indicated where levels of foetal haemoglobin are higher than normal and may vary between 20-90%. HbA2, which usually accounts for up to 3% of normal adult haemoglobin, may be non-existent, reduced, normal or slightly elevated.

- (iv) Molecular methods. These are specialised ways of

confirming or obtaining more specific information in a diagnosis, using DNA investigation to establish, for example, the mutations that cause a condition - information that, in addition to confirming a diagnosis, also provides an indication of the clinical severity of the disease.

An investigation of haematological parameters as well as of genetic mutations to the α , β and γ genes are essential steps, both in confirming a diagnosis of thalassaemia and in deciding treatment. Although the diagnosis of β -thalassaemia major is usually fairly straightforward, difficulties may arise, particularly in developing countries where the prevalence of diseases such as malaria can complicate diagnosis. For example, malaria can cause anaemia and splenomegaly, and although the haematological laboratory findings are quite different, it may be necessary to treat the patient with anti-malarial drugs before reassessing the patient's condition and diagnosis.

Other conditions may also cause anaemia and splenomegaly as well as raised HbF levels and a differential diagnosis is necessary with additional clinical and laboratory tests. It is very important to confirm an accurate diagnosis of thalassaemia before treatment.

The major haemoglobin disorders

α -globin chain disorders

α -thalassaemias
HbH disease
 α -thalassaemia hydrops foetalis
(= Hb Bart's hydrops foetalis)

β -globin chain disorders

sickle cell disorders
sickle cell anaemia (HbSS)
HbS/ β -thalassaemia
HbSC disease
HbSD disease
other rare sickling disorders

 β -thalassaemias
 β -thalassaemia major
 β -thalassaemia intermedia
HbE/ β -thalassaemia
other rare thalassaemias

The treatment of β -thalassaemia major

Over the last three decades, clinical observations and research have established that thalassaemia major is a treatable condition. Studies have shown that regular transfusion therapy with safe and appropriately processed blood, combined with regular and effective iron chelation tremendously increase patients' survival and quality of life.

This recommended treatment regime is focused on fighting the anaemia prevalent in thalassaemia and all its consequences, and on preventing progressive tissue iron-loading that may result from the disease itself and from the blood transfusion therapy used to treat the anaemia.

Chapter 3

Blood transfusion therapy



Regular blood transfusions greatly contribute to the quality and length of life of patients with thalassaemia major, and have been a central aspect of the treatment of thalassaemia since the 1960s.

If not effectively managed, the severe anaemia and over-expansion of the bone marrow characteristic of thalassaemia major can lead to:

- poor growth
- facial and other bone deformities
- fragile bones and bone fractures
- enlarged liver and spleen (organomegaly)
- impairment of normal physical activities

Regular blood transfusions on a life-long basis - at least until a cure for thalassaemia major becomes available - can counteract or even prevent the development of these symptoms. However, several factors must be taken into account when beginning blood transfusion therapy. This chapter will discuss:

- I. When transfusion therapy should begin.
- II. How to ensure safe transfusions.
- III. What to transfuse and
- IV. How to establish the most appropriate blood transfusion therapy regime.

When to begin transfusion therapy

Transfusion therapy should only begin once a diagnosis of thalassaemia major is confirmed. As mentioned earlier, a confirmed diagnosis of thalassaemia major is based on:

- (i) laboratory tests (e.g. haematological, molecular or haemoglobin electrophoresis and other laboratory tests, such as high pressure liquid chromatography, (or HPLC)
- (ii) genetic analysis to identify the nature of β - and α -thalassaemia mutations, as well as the presence of the Xmn1 restriction enzyme site - an indicator that can

help predict the severity of the disease and identify the treatment regime most appropriate to each patient.

The severity of anaemia is usually assessed on the basis of levels of haemoglobin (Hb) in the blood. This is measured in grams (g) per decilitre (dl - 1/100th of a litre) of blood. Haemoglobin is easily measured in a laboratory, usually using a machine called a cell counter. Older methods such as the Sahli technique can also reliably measure haemoglobin. A normal Hb level is generally considered to be between 13-16g/dl in men and 11-14g/dl in women and children. In both men and women, haemoglobin levels of between 8-11g/dl represent moderate anaemia, with severe anaemia at levels less than 8g/dl.

Patients should only begin transfusion therapy once thalassaemia has been confirmed through laboratory diagnosis and molecular studies (as described above), and when:

- Hb levels are registered at less than 7g/dl on two successive occasions, more than two weeks apart. Very occasionally, patients may thrive and grow normally with Hb values between 6-7g/dl but a decision not to transfuse under these circumstances requires great clinical experience and careful observation.
- Hb levels are >7g/dl but accompanying physical characteristics are noted, such as:
 - facial changes
 - poor growth and limited weight gain
 - bone fractures
 - extra-medullar hematopoiesis, resulting in tumour masses

Where these criteria are observed, transfusion therapy should not be delayed.



Ensuring safe transfusion therapy

Adequacy or availability

- As blood transfusion is a lifelong treatment for thalassaemia, health authorities must promote policies of blood donations in order to secure an adequate, continuous supply of blood for patients.

Preventing the transmission of infectious agents

- Blood transfusion therapy should be made as safe as possible for the patient. This means that the risk of infectious agents such as viruses, bacteria or parasites being transmitted from a blood donor to a patient should be kept to an absolute minimum. In order to minimise the risk of infectious agents being passed on through blood donations, public health authorities must:

- Promote policies aimed at the selection of healthy donors and promote regular, voluntary blood donation services. Paid donations should be avoided and patients should not be required to find friends and relatives to donate equivalent blood units used (replacement donation).
- Donors' blood should be screened for clinically important infectious agents, such as hepatitis viruses (B and C), HIV1+2 (the causative agents of AIDS) and syphilis. In some countries it may be necessary to screen for other infectious agents, such as malaria, where these are prevalent.
- Ensure that national blood transfusion services, including laboratories and other services provided by blood banks such as the storage and transport of blood products, meet international standards.

Blood group genotype

The safety of blood is also associated with other factors, such as ensuring that patients are tested (typed) for as many of the important blood group systems as possible. For example, patients must be tested to establish their blood group and whether they are Rhesus positive or negative, along with other blood group systems such as Kell, Kidd and Duffy. Once transfusion begins, it may be difficult to determine all the blood group types present. It is therefore important to test for the full red cell genotype before the first transfusion. Ideally, patients should be tested for the presence of new antibodies to red



cells before every transfusion. Matching as many of the patient's and donor's blood group systems as possible is an important means of reducing reactions associated with blood group mismatching or incompatibility. Red blood cells have 26 blood group systems, including 600 different antigens. While it is not possible to match all of these, every effort should be made to match at least the most common, such as the ABO, Rhesus and Kell systems.

What to transfuse

Blood collected from a donor is called whole blood, which, in addition to red blood cells, also contains plasma, white blood cells and platelets (see section on blood). About 450ml of whole blood - a unit - is collected from each donor. Once the plasma, white blood cells and other cells are removed, about 250ml of red blood cells - a unit of packed red cells - remain for transfusion. Other fluids, such as anticoagulant and nutrients, are also added to the pack -- the amount of fluids added depends on how the blood unit has been processed.

Patients with thalassaemia major lack red blood cells. Therefore, patients receiving blood transfusion therapy should ideally only receive red blood cells, which contain none of the other components of whole blood - e.g. plasma, white blood cells and platelets. If a patient receives whole blood, there is a risk that the body's circulatory system will be overloaded, developing complications such as heart failure and the accumulation of liquid in the chest area (pulmonary oedema). The removal of white cells and platelets from whole blood also decreases the risk of unwanted effects such as fevers during and after the blood transfusion. Although such symptoms can be treated, every effort should be made to avoid any complications by providing only that component of blood the patient requires.

How packed red blood cells are obtained

Red blood cells are separated from whole blood in a laboratory through a process of spinning the blood (centrifugation), which removes over 70% of the plasma and white blood cells found in whole blood. In the course of centrifugation, red blood cells separate from the rest, accumulating at the bottom, while plasma, white blood cells and thrombocytes rise to the top, making them easy to remove. A number of solutions can be added to the red blood cells, such as anticoagulants, which



prevent the cells sticking together, and nutrients or additives that can extend the life and preserve the quality of red blood cells. SAGM (saline, adenine, glucose, mannitol), PAGGS-M (phosphate, adenine, glucose, guanosine saline-mannitol), AS-3 (Nutricel system) and ADSL (adenine, dextrose, saline-mannitol) are some of the additive solutions used. CPD (citrate, phosphate dextrose), CPDA-1 (citrate, phosphate, dextrose, adenine) and CP2D (citrate, phosphate, double dextrose) are anticoagulants.

In Europe a combination of CPD/SAG-M is used to maintain the viability of red blood cells, keeping them for 42-48 days, while in the US a combination of CPDA-1/AS-3 or CP2D/AS-3 is used.

Patients with thalassaemia should receive transfusions of packed red cells, preferably not more than 7 days old. Even where the nutrients described above have been added, patients should not be given packed red cells more than two weeks old, because there are as yet no reliable studies to confirm that red blood cells stored for longer are as beneficial in the treatment of thalassaemia major as those kept for a shorter period.

Other processes that may improve the quality and safety of blood include:

- i. Washed packed red blood cells. The presence of proteins in transfused blood can cause moderate to severe reactions in patients. Although the process of centrifugation described above removes more than 70% of plasma and proteins from whole blood, the quality of packed red blood cells can be significantly further improved by 'washing' them in a saline solution to remove the maximum amount of plasma and proteins possible. This process is not usually required for most patients. Once the red cells have been washed, they usually have to be used within 24 hours.
- ii. Leucoreduced packed red cells. International guidelines recommend that the number of white blood cells is kept below 1×10^6 cells per unit of red blood cells, in order to keep the unwanted reactions associated with leucocytes to a minimum. These reactions, usually causing fever, are believed to result from white blood cells releasing chemicals known as chemokines. In addition, removing white blood cells also removes infectious agents carried by white blood cells, such as the bacteria *Yersinia Enterocolitica*, CMV, EBV, B19 and



HAV (see abbreviations) -- pathogens not screened for in blood banks but which may under certain conditions cause severe infections.

Methods for reducing the number of white blood cells (leucoreduction or leucodepletion) include:

- (a) Filtration. White blood cells and their associated infectious agents can be most effectively removed from donor's blood using special filters connected to blood bags. International guidelines recommend delaying the filtration of blood until 4-8 hours after collection, storing it in a refrigerator in the interim. This delay in filtration may allow enzymes in the white blood cells (phagocytes) to destroy bacteria (phagocytosis) such as *Yersinia Enterocolitica*, which can enter and multiply within white blood cells (see opposite). Filtration may be carried out in the blood bank or at the patient's bedside during transfusion. However, while bedside filtration can effectively remove white blood cells, it may be more difficult to ensure quality control.

Leucofiltration has taken on added significance in recent years, particularly for young β -thalassaemia patients planning to undergo or have undergone bone marrow transplantation (BMT). This is because white blood cells are associated with a virus called cytomegalovirus (CMV), which can cause severe or even lethal infections in patients with weak immune systems (immune suppressed) - as is the case with transplanted patients.

Where blood banks are not able to carry out plasma separation, or to wash or filter blood in the way described above, whole blood collected from the donor should be stored in a refrigerator at 4°C for 24-48 hours, allowing the red blood cells to collect at the bottom of the blood bag, while the plasma, white blood cells, platelets and debris known as the buffy coat rise to the surface, where they can be removed as much as possible using very simple laboratory equipment. However, this process is 1,000 times less efficient than filtration.

Effectiveness of different techniques for removing white blood cells:

- Buffy coat removed from blood left standing in a refrigerator to separate 'naturally': $< 1.2 \times 10^9$ white blood cells/unit of blood remain

blood filter



phagocyte filled with bacteria

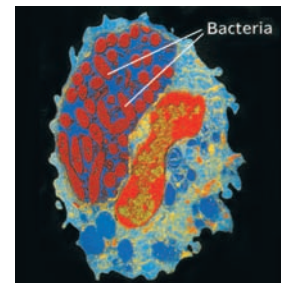

- Red blood cells separated by centrifugation and washed in saline solution: $<1 \times 10^7$ white blood cells/unit of blood remain
- Packed RBCs filtered at the bed side: $<5 \times 10^6$ white blood cells/unit of blood remain
- Packed RBCs filtered in a blood bank laboratory: $<5 \times 10^6$ white blood cells/unit of blood remain
- Pre-storage filtered RBC: $<1 \times 10^6$ white blood cells/unit of blood remain

Ideally, all patients with thalassaemia major should receive transfusions of red blood cells that are filtered before storage, washed, fully cross-matched and with anticoagulant/nutrient solutions added. However, where this is not possible, special blood preparations should be considered for patients with particular requirements:

1. Washed RBCs should be prepared for patients lacking a special protein in their blood, called IgA, and for those who frequently develop serious allergic reactions to blood transfusion therapy. Some patients without IgA deficiency who nonetheless develop repeated fevers with filtered blood may also require red cells to be washed before transfusion.
2. Frozen or cryo-preserved RBCs should be provided to patients with rare RBC antigens for whom it is difficult to accurately cross-match blood donors. In Europe and the US frozen RBCs from rare groups are kept in specialised medical centres, frozen at -60°C in a 40% glycerol solution - a condition in which they can be stored for up to 10 years.
3. RBCs treated with radiation should be provided to patients that have received transplants, or are candidates for transplant in order to prevent a severe condition known as graft versus host disease (see later).
4. Leucoreduced RBCs should be provided to patients who frequently develop reactions associated with white blood cells after blood transfusions. Leucoreduced blood should also be provided to newly diagnosed young patients planning to undergo bone marrow transplantation, in order to avoid infection with cytomegalovirus (CMV), as well as to transplanted patients who may need blood transfusion in order to avoid the recurrence of CMV.

Drawing up a transfusion regime

Calculating the volume of blood needed

The volume of blood a patient requires and the rate of transfusion depends on the patient's age and clinical status, as well as the solutions added to preserve the red blood cells to be transfused, the haematocrit (a parameter similar to haemoglobin) of the donor's RBCs, and the target level of haemoglobin.

In moderate -- as opposed to hyper- or super- -- transfusion regimes (recommended by most thalassaemia specialists), patients usually receive 10-15ml of concentrated red blood cells per kg of body weight (volume), transfused over 3-4 hours (based on a 75% haematocrit of the donor's RBCs) (rate), every 2 to 5 weeks (interval). A non-splenectomised patient requires approximately 180ml of pure red blood cells/kg/year, while a splenectomised patient requires about 133ml/kg/year.

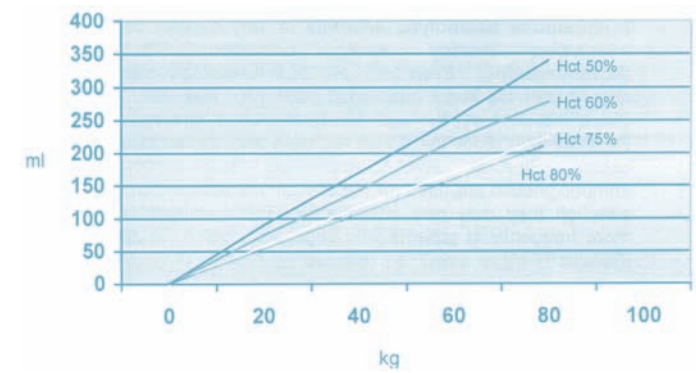

3a Amount of donor blood, depending on haematocrit, required to raise the patient's haemoglobin by 1 g/dl.

From TIF's "Guidelines for the Clinical management of Thalassaemia"

Where a patient suffers cardiac problems or where blood transfusions begin when levels of haemoglobin are below 5g/dl, smaller volumes of blood are administered, at a slower rate -- for example, 2-5ml of RBC/kg/hour. Various tables and graphs are (3a, 3b) available to assist medical staff in calculating the exact volume of blood a patient requires.

Transfusion regimes should aim to keep patients' haemoglobin levels at between 9-10.5g/dl before transfusion and not more than 15g/dl after transfusion. Under this regime, patients will experience:

- minimal expansion in bone marrow
- normal growth and increased physical energy
- no or delayed enlargement of the spleen
- decreased viscosity of the blood associated with risk of thromboembolic complications, headaches and nose bleeds and

3b Guidelines for choosing how much blood to transfuse

Target Increase in Haemoglobin Level	Haematocrit of Donor Red Cells			
	50%	60%	75%	80%
1 g/dl	4.2 ml/kg	3.5 ml/kg	2.8 ml/kg	2.6 ml/kg
2 g/dl	8.4 ml/kg	7.0 ml/kg	5.6 ml/kg	5.2 ml/kg
3 g/dl	12.6 ml/kg	10.5 ml/kg	8.4 ml/kg	7.8 ml/kg
4 g/dl	16.8 ml/kg	14.0 ml/kg	11.2 ml/kg	10.4 ml/kg

From TIF's "Guidelines for the Clinical management of Thalassaemia"

- lower deposits of excess iron on the organs
- The interval between transfusions may also take account of other factors, including the patient's work or school schedule and the distance he/she must travel to reach the transfusion centre. In so far as possible, the timing of transfusions should be organised to suit the patient's lifestyle as well as to meet medical requirements.

Assessing the effectiveness of a blood transfusion regime

The effectiveness of a blood transfusion programme is usually measured in terms of the rate of fall in levels of haemoglobin, which should not exceed 1g/dl/week in splenectomised patients and 1.5g/dl/week in non-splenectomised patients.

If Hb levels are found to fall at a greater rate, the following causes may be investigated:

- antibodies (alloimmunisation) to RBCs (see transfusion-associated reactions)
- enlarged spleen (hypersplenism) and/or liver (hepatomegaly). Where a patient requires more than 200ml RBC/kg/year, for example, the possibility of an enlarged spleen should be investigated
- poor quality blood, meaning red blood cells have a shorter lifespan and function less effectively
- bleeding (e.g. from the gut)
- increased red cell destruction from use of medication (e.g. ribavirin)
- increased red cell destruction from infection (e.g. malaria)

Haemoglobin levels should ideally be measured before and after every transfusion, in order to assess the effectiveness of the treatment regime. If this is not possible, Hb levels should be measured as often as possible - once a week, once every 15 days, or whenever the patient receives a transfusion.

Transfusion-associated reactions

A blood transfusion can cause an unwanted reaction or complication in a patient, known as a transfusion reaction. A transfusion reaction (TR) is any unfavourable event that occurs in a patient during or after a blood transfusion.



tion. About 4% of blood transfusions (and with poor quality of blood, this can be significantly greater) are associated with some form of unwanted or adverse reaction. A blood transfusion involves introducing a foreign substance -- a donor's blood -- into the patient's body. It is therefore reasonable to expect a reaction from the patient's immune system -- just as reactions are expected in bone marrow or organ transplantation. Indeed, every medical procedure has benefits as well as potential risks to a patient, which must be carefully evaluated by medical staff.

The reactions that can affect patients receiving a blood transfusion are divided into two categories:

- immune mediated transfusion reactions -- where the patient's immune system responds to the transfused blood
- non-immune mediated transfusion reactions -- reactions that are not the result of the patient's immune system

Both categories of reaction can occur during or near a transfusion (acute reactions) -- after just a few millilitres of blood have been introduced, during the course of the transfusion, or after it has finished -- or a reaction may be delayed, occurring several days or weeks after a transfusion, or even over the longer term.

The following tables (1,2,3) indicate the types of category A and B reactions that can occur, and their frequency (see 3c, 3d, 3e).

(This section uses a number of more technical medical terms that will be unfamiliar to the average reader, who may wish to consult the Glossary for definitions. It is hoped that by making these terms accessible, patients and parents may feel more confident in their interaction with medical staff.)

3c table 1

Immune mediated transfusion reactions

Acute	frequency	Delayed	frequency
Haemolytic (intravascular)	1/25,000	Alloimmune	1/100
Anaphylactic	1/50,000	Haemolytic (extravascular)	1/2,500
Febrile non-haemolytic	1/100	Platelet refractoriness	1/10
Allergic (urticarial)	1/100	Graft vs Host Disease (GVHD)	rare
Transfusion Related Acute Lung Injury (TRALI)	1/10,000		

3d table 2

Non-immune mediated transfusion reactions

Acute	frequency	Delayed	frequency
Haemolytic (in vitro)		Metabolic iron overload	long term
Metabolic:		Infectious:	
Coagulopathy	rare	1. Bacterial	
Hypothermia	rare	Gram negative	1/15,000
Citrate toxicity	rare	Gram positive	1/2,000
Hypocalcaemia	rare	2. Viral*	
Hyperkalaemia	rare	HBV	1/60,000
		HCV	1/100,000
		HIV 1&2	1/700,000
		HTLV 1&2	1/650,000
		CMV	7/100
		E-B	1/200
		B19	rare
		3. Prions: Creutzfeld Jakob	?
		4. Parasitic** (eg malaria)	rare
Embolic	rare		
Circulatory overload	1/10,000		

- Frequency of viral contamination varies widely among countries, depending on the quality of public health and blood transfusion services and on the local prevalence of these pathogens. The frequency shown in this table refers to those commonly reported in Europe in recent years

** The frequency of parasitic transmission is more common in developing countries.

Table 3 indicates the cause of some blood transfusion-related reactions, the stage at which they most frequently occur and their associated symptoms.

3e table 3

Causes, time of occurrence and symptoms of transfusion-related reactions

Type of reaction	Timing	Cause	Symptoms
acute haemolytic	after infusion of a few mls of blood	ABO incompatibility	dyspnea, chest constriction, fever, chills, lumbar pain, hypotension, shock, renal failure
anaphylactic	"	congenital deficiency in IgA	skin flushing, hives, itching, dyspnea, vomiting, diarrhoea, chest pain, hypertension, loss of consciousness, shock
air embolism	"	air entering the system	cough, dyspnea, chest pain and shock
bacterial contamination (sepsis)	towards the end or after completion of transfusion	transmission of bacteria through transfused blood	fever, chills, vomiting, diarrhoea, hypotension, shock, renal failure, DIC
circulatory overload	"	transfusion proceeding too quickly	dyspnea, cyanosis, increased systolic pressure
TRALI (Transfusion Related Acute Lung Injury)	"	reaction between transfused anti-leucocyte antibodies and patients' granulocytes	dyspnea, cyanosis, cough, hypotension
FNHTR (Febrile Non-Haemolytic Transfusion Reaction)	"	reactions between leucocyte antigens in transfused blood and anti-leucocyte antibodies in the patient's blood -- some reactions believed to be due to transfusion of proteins called cytokines, produced by leucocytes during blood storage	increase in patient's temperature by 1°C or more without any other medical explanation
allergic (urticaria)	"	results from foreign allergens in the donor's blood reacting with patient's antibodies or antibodies in the donor's blood reacting with patient's allergens	urticaria (hives), rash, localised oedema

Causes, time of occurrence and symptoms of transfusion-related reactions (cont.)

Type of reaction	Timing	Cause	Symptoms
GVHD (Graft vs Host Disease)	3-30 days	patient's HLA antigens activate donor's T-lymphocytes -- particularly in (i) immuno-suppressed patients; (ii) foetuses receiving intrauterine transfusion; (iii) neonates receiving exchange transfusion; (iv) recipients of relatives' blood	fever, enterocolitis, watery diarrhoea, dermatitis, erythoderma and pancytopenia
alloimmune reaction (see Table 4)	after some days or weeks	patients develop antibodies against certain RBC antigens, resulting in haemolysis of transfused cells	mild fever, chills, moderate jaundice and unexplained decreases in Hb values (risk of developing condition can be reduced by beginning transfusion therapy early in life -- before the age of 3)
haemolytic delayed anamnestic response	3-7 days	as above, but antibodies may be undetectable in pre-transfusion laboratory testing, with immune system producing massive amount of antibodies upon transfusion	

Treating transfusion reactions

The prognosis for a transfusion related reaction depends on the severity of the reaction. The following outlines how some of these reactions may be treated:

Serious complications:

- Acute Haemolytic Transfusion Reaction [AHTR], and phylactic, sepsis (bacterial contamination) and air embolism -- the transfusion is stopped. Fluids may be administered intravenously and various medications used to treat or prevent associated medical conditions such as Disseminated Intravascular Coagulopathy (DIC), renal failure and shock.

- Overload of the circulatory system may be treated by administering oxygen and diuretics -- to help urination.
- Transfusion Related Acute Lung Injury (TRALI) may be resolved by appropriate respiratory support.
- The effects of delayed haemolytic anamnestic response and alloimmunisation may be reduced with corticosteroids.
- Graft vs Host Disease (GVHD) requires appropriate support therapy.
- Viral contamination should be treated according to the virus concerned.

Benign complications:

- Febrile Non-Haemolytic Transfusion Reaction (FNHTR) may be addressed with antipyretics.
- Allergic (urticaria): rash and itching may be reduced with antihistamines.

Preventing transfusion reactions

Transfusion services and other relevant departments must implement rigorous policies, ensuring that optimal transfusion procedures are always followed and the health and safety of patients are protected. Medical staff must strictly adhere to established transfusion standards and protocols. Incorrect patient (and so blood group) identification is by far the most commonly reported error in transfusion related fatalities.

1. Samples for blood typing and compatibility testing must be clearly identified. The patient's full name and date of birth should be indicated on the tube label before a sample is drawn, and the data on the Transfusion Application Form checked.
2. A medical officer must verify that any infusion equipment is being used according to the manufacturer's recommendations.
3. Before any blood units are attached to equipment, a medical officer must carry out a visual check of the blood unit for evidence of contamination -- e.g. colour change to dark purple, clots or haemolysis, and verify that the blood has not expired.
4. Compatibility between the patient and the blood unit must be verified by checking the certificate of the patient's blood group against the blood group as shown on the blood unit label.

5. Identification details of the blood unit(s) transfused should be noted in the patient's record, so that donor(s) may be traced if necessary.
6. The patient should be carefully observed over the course of the transfusion, particularly in the early stages when transfusion reactions (TRs) are more likely to occur.
7. Blood components should be transfused within the recommended time to avoid compromising clinical effectiveness, safety and ease of administration.
8. Rapid transfusion of cold blood may be dangerous. Frozen units must be handled with great care, as the containers may be brittle and may easily crack at low temperatures.
9. The efficacy of the transfusion should be determined, by recording the appropriate pre- and post-transfusion parameters.
10. Any observed reaction should be carefully noted and reported. All serious complications should be investigated (draw a post-transfusion sample and send it with the unused blood product and its administration set to the blood bank for serological incompatibility investigation and bacterial culture test).
11. In case of repeated TR, investigation for the presence of irregular antibodies outside the ABO and Rh systems is recommended. When repeated FNHTR occurs, leuko-cyte-poor components should be used.
12. It is important to bear in mind that some complications may be delayed, such as the onset of disease transmitted by blood transfusion. Where a donor is found to have seroconverted, patients that have received their blood must receive a medical follow-up.

Blood banks must have in place a system of quality assurance that guarantees the quality of blood products used. Such a system should ensure that:

1. The selection of donors, taking of blood, and the manufacture, laboratory testing, storage and distribution of blood products are performed in accordance with the principles of Good Manufacturing Practice.

2. The tasks and responsibilities of staff involved in these activities are clearly identified.
3. The correct materials are used.
4. A system of internal audit is in place, in order that the applicability and effectiveness of quality control can be regularly assessed.
5. Any errors are fully reported and lessons learnt.

Many hospitals in Europe and the US have Blood Transfusion Committees that include representatives of the blood transfusion service and the main clinical units with significant transfusion activity. Such committees can further enhance the efficacy of transfusion practice, by:

1. Defining blood transfusion policies adapted to local clinical activities.
2. Conducting regular evaluations of blood transfusion practices.
3. Analysing any undesirable event linked to a blood transfusion, and taking any corrective measures necessary.

Chapter 4

Iron Overload and Iron Chelation

As explained in previous sections of this book, thalassaemia causes iron to accumulate in the body. There are two main ways in which patients with thalassaemia absorb iron: from the diet, and from transfused blood. If this excess iron is not removed, it can cause damage to important organs such as the liver and heart. Thalassaemia patients must therefore use special drugs called chelators, which remove iron from the body.

Iron in a healthy body

A normal healthy adult stores about 4g of iron in the body, of which about 3g are used to make haemoglobin in the red blood cells. As explained earlier, when red blood cells mature and die their haemoglobin is broken up into its constituent parts: haem and globin. The iron released from the haem is transferred by a protein carrier molecule known as transferrin, to be recycled to make more haem for new red blood cells. The chemical substances that make up the globin protein, known as amino acids, are reused to make new globin.

These processes mean that in a normal healthy adult, the body reuses most available iron, leaving very little to be excreted. Just 1mg of iron is taken out from the body of a healthy adult each day - mostly in the urine, faeces, via the skin and -- in women -- through menstruation. The iron taken out of the system in this way is replaced by iron absorbed by the gut from the diet (4a).

Iron in thalassaemia

In untransfused thalassaemia intermedia and thalassaemia major, the body attempts to compensate for the patient's severe anaemia by absorbing significantly more iron from the gut than normal (2-5g/year compared to 0.0015g/year in healthy individuals), in order to make more red blood cells. How much more iron is absorbed depends on the severity of the anaemia: the more severe the anaemia,

the more the bone marrow expands as it tries to make more and more red blood cells, and so the greater its demand for iron. Other factors may also play a part in determining the amount of iron absorbed by the gut. For example, the presence of vitamin C increases the amount of iron absorbed, while tea and some cereals lead to a decrease. However, the most important way of reducing the amount of iron absorbed through the gut is to ensure that patients maintain good haemoglobin levels. It is therefore important that patients receive regular blood transfusions, keeping haemoglobin levels above 9g/dl (measured before transfusion). Patients that are poorly transfused may absorb an extra 1-5mg/day (or about 0.4-2g/year) of iron from the gut.

The main source of iron overload in patients receiving transfusions however is blood transfused. In fact, the amount of iron the patient absorbs through blood transfusions is far greater than that absorbed from the diet through the gut. It is therefore important that patients on regular blood transfusions, use iron chelators -- drugs that bind with iron and remove it from the system.

Each millilitre (ml) of red blood cells contains about 1.16mg of iron. An average unit of blood contains about 250ml of packed red cells - i.e. 250 x 1.16 or between 200-290mg of iron. The iron released from the breakdown of these red blood cells is a major source of the iron that accumulates in the bodies of patients receiving lifelong blood transfusions. For example, a patient receiving 30 units of blood per year will have an excess of around 6g of iron a year (200 x 30 = 6,000 mg = 6g), or about 15-16mg/day. The body is unable to excrete such a large amount of extra iron, and so it piles up in the tissues and organs of the body. If this iron is not removed by medical intervention, it can be extremely harmful, causing some of the most serious complications in β -thalassaemia major.

The clinical symptoms of iron overload generally appear around the age of 10, although evidence of the toxic effects of iron has been found in the liver of much younger children. Injury to the liver - known as fibrosis - begins within two years of the start of transfusions. Serious liver injury (cirrhosis) can develop before the age of 10 if there has not been treatment to remove the excess iron, particularly where the patient has hepatitis B

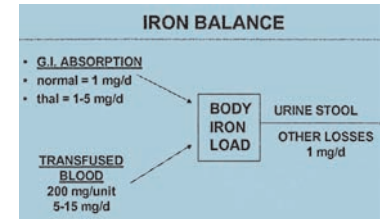
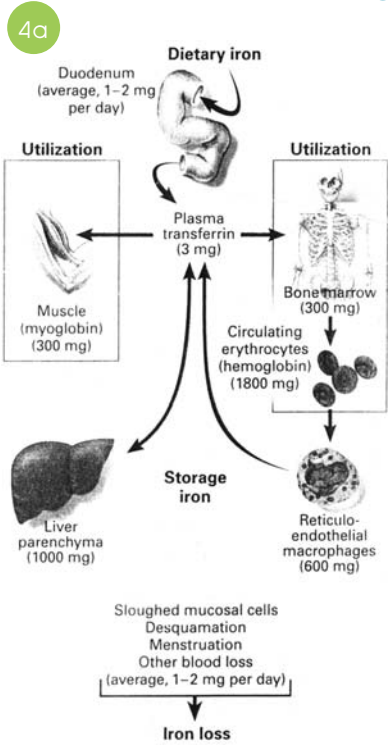

4b Increase of transfusional iron as needs for blood transfusions increase with age

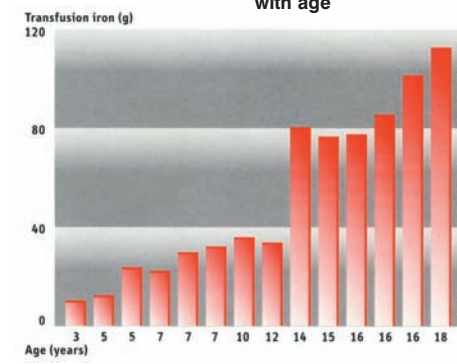

(From Cohen and Schwartz - Chelation therapy in chronic iron overload, 1977, symposia specialists, Inc., Box 610397, Miami Florida)

and/or C. Heart disease - one of the most frequent causes of death in thalassaemia major - has also been reported within 10 years of the start of a transfusion regime, although heart failure does not usually occur until after 15 years or more.

Iron loading is also the most important cause of delayed sexual maturation in patients with thalassaemia, affecting about half of both male and female patients. In addition, iron loading can cause difficulties in women trying to conceive (around 25% of cases), and is frequently a cause in the development of diabetes mellitus.

Over the long term, excess iron causes bone complications and damage to other important organs, such as the thyroid and parathyroid. Therefore patients must receive treatment to remove excess iron, which will otherwise accumulate in the body with serious effects on the patient's quality and length of life.

How excess iron damages the body

As iron accumulates in the body -- either as a result of thalassaemia itself, or of blood transfusion therapy, or both -- the main iron-carrying protein in the blood, transferrin, gets filled up (saturated) with iron. Without any iron-free transferrin available, unbound iron -- which is very harmful to the body -- begins to circulate in the blood. Iron also accumulates in the tissues, bound to protein storage molecules called ferritin (4c) and haemosiderin. Iron stored in these proteins is less harmful than unbound iron. However, the body constantly breaks down ferritin and haemosiderin, which then release some unbound iron. Iron can also be released from storage proteins when the patient is ill.

Non-transferrin bound iron - the iron left over in the system when there is no more transferrin to bind to it -- is unstable. That means it can easily gain or lose a negative charge, called an electron. When iron gains an electron, it changes from having three positive charges (a type of iron known as 3+ or ferric iron) to having two positive charges (a type of iron known as 2+ or ferrous iron). As iron moves between the 2+ and the 3+ states, it produces harmful substances called free radicals, which can cause extensive damage to the body's tissues.

The best-known process by which free radicals are produced is known as the Fenton reaction -- a chemical reaction simplified as follows:

Hydroxyl radical (HO) generation



Desferrioxamine (DFO) or Desferal

As the body has no effective means of removing iron, the only way to remove excess iron is to use drugs called iron chelators (iron binders), which form a compound with iron that can be excreted from the body through the urine and/or stools.

Desferrioxamine (DFO) was the first iron chelation drug to be manufactured. First produced in the 1960s, DFO (4d) was introduced onto the market in the early 1970s for the treatment of thalassaemia major. DFO works in two ways: the first is a slow process in which DFO binds (chelates) iron to form a substance called ferrioxamine (4e), which is then excreted from the body. The second role of DFO is to decrease the toxicity of iron in the body by mapping up free radicals. This is a rapid process.

DFO chelates iron from two main sources or pools of iron in the body. The first pool is iron formed by the breakdown of red blood cells. This pool accounts for 70% of the iron chelated by DFO, and is passed out of the body in the urine. The second pool of iron chelated by DFO comes from the liver -- the biggest iron-storing organ in the body. Iron stored in the liver is released when two substances -- ferritin and haemosiderin -- are broken down in the liver cells (hepatocytes). DFO in the hepatocytes then binds with the iron, before being passed out of the body in stools. DFO does not bind with iron already bound to transferrin.

Each molecule of DFO binds one atom of iron to form ferrioxamine (4e). This means that if DFO was 100% effective, each gram of DFO would excrete about 93mg of iron. This is not however the reality. The level of effectiveness depends on the dose and way in which DFO is administered, the size of the iron stores, the level of vitamin C in the body, and the degree to which the patient complies with prescribed chelator medication.

The role of vitamin C. Vitamin C is a reducing agent - that is, it can help iron convert from iron 3+ to iron 2+.

4d Desferrioxamine B, the active substance of Desferal

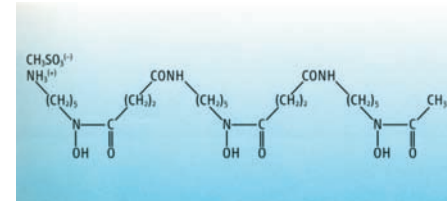

4c Ferritin molecule

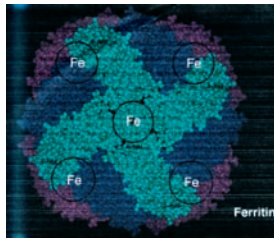

4e Ferrioxamine B

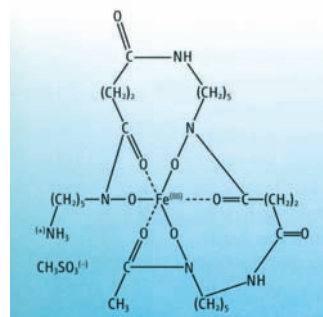

This is very important because iron 2⁺ can move more easily around the body than iron 3⁺, and is also the form of iron that most easily binds to chelators such as DFO. For this reason iron 2⁺ - the ferrous form - is often called the "chelatable" iron, while iron 3⁺ - the ferric form - is the immobile iron found in storage compartments of the body such as the liver, bound to carrier proteins such as ferritin and haemosiderin. One way to increase the amount of iron released by these proteins is by administering vitamin C supplements along with DFO.

Experts advise that patients with thalassaemia should take vitamin C every day, ideally at the same time as DFO is administered. However, it is generally recommended that patients only begin taking vitamin C supplements after they have been receiving DFO for a few weeks.

Recommended daily doses of vitamin C are 50mg for children <10 years of age and 100mg for older children. Doses should not exceed 200mg/day. Patients whose diet regularly includes oranges or fresh juice may not need additional vitamin C supplements: one large orange, for example, contains 75mg of vitamin C, while 100ml of fresh orange juice contains 50mg of vitamin C.

As with all medicines and supplements, doses should only be adjusted in consultation with a doctor. It is important to note that too much vitamin C can have a toxic effect on patients, mobilising too much iron. Vitamin C supplements may therefore be particularly harmful to patients who are not receiving DFO, as iron mobilised by the vitamin C will remain unbound, causing tissue damage.

When to start iron chelation treatment

Patients with thalassaemia major should only begin DFO treatment once they have begun regular blood transfusion therapy. DFO does not solve any of the problems caused by insufficient blood transfusion therapy, such as anaemia, bone changes or enlargement of the liver and spleen. DFO should not be given to untransfused or under-transfused patients unless they are over 10 years old or there is evidence of iron-loading.

As a general rule, patients should begin iron chelation treatment once they have had 10-20 transfusions, or when ferritin levels rise above 1000µg/l.

How to prepare, store and use desferrioxamine

It took more than 30 years of clinical experience for

physicians and scientists to agree on the best way to administer DFO in order to effectively remove iron from the body while avoiding any toxic effects of administering too much of the drug.

Because of the large size of DFO molecules, the body absorbs little DFO via the gut. The best way of delivering DFO is therefore subcutaneously (under the skin) or intravenously through a vein. At the same time, because DFO is rapidly eliminated from the blood (half-life of 5-10 minutes) the drug must be delivered slowly over a period of time, in order to obtain a steady concentration in the blood for as long as possible. DFO is administered via a specially designed pump that slowly infuses the drug under the skin -- over 8-12 hours, at least 6 days a week. The exact dose for each patient is calculated on the basis of age, body iron load and clinical condition. In general, average doses for children should not exceed 20-40mg/kg of body weight, as high doses may slow growth. The standard dose for adults is 30-50mg/kg body weight.

Preparing DFO

DFO is a dry white powder, available in 500mg or 2g units. Each unit is contained in a small glass bottle or vial of dry white powder, which should be diluted to a 10% solution before use. To make up a 10% solution of DFO from a 500mg vial, for example, 5ml of distilled water should be added to the powder. (Distilled water is available from pharmacies.) The solution should then sit for a few minutes to allow the powder to dissolve. It is important not to shake the vial - to help the powder dissolve, the vial may be rolled in the palm of the hand or on a flat surface such as a table. Once the powder is dissolved, the solution is drawn up into a syringe and placed in a small battery-operated pump. The pump slowly depresses the plunger of the syringe, to release the drug into the body over the required period - between 8-12 hours. The syringe empties according to the number of hours selected. Some of the most commonly used pumps have an in-built alarm that sounds if the syringe gets stuck, or if it has finished infusing the drug.

Storing DFO

A prepared solution of DFO can be stored at room temperature (23°C) for a maximum of 24 hours. In hot climates, it is important to keep prepared solution in a cool place, keeping it refrigerated at 4°C if it is not to be used immediately. Refrigerated solution can be stored for around five days. However, if the solution becomes cloudy and discoloured, it should be thrown away imme-

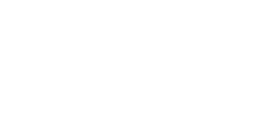

diately. It is best to remove the DFO solution from the fridge about two hours before use, to allow it to warm up to body temperature.

DFO may also be pre-mixed for subcutaneous or intravenous infusion by a pharmacist under special sterile (aseptic) conditions. Pre-mixed DFO remains stable for up to 2 weeks at 4°C but if DFO is pre-mixed by a patient and not a pharmacist, the solution should not be kept for more than a day or two, as it may not be sterile. Injecting a non-sterile, contaminated solution can cause reactions.

Administering DFO subcutaneously

To administer DFO subcutaneously the syringe containing DFO is fitted into the pump, and then connected to a thin plastic tube leading to a very thin needle, which is inserted under the skin. The DFO is then released into the space between the skin and the muscle or fat that lies beneath it.

Over the years, pumps have become considerably smaller, lighter and quieter than older models. This makes them less obvious and easier to use discreetly during the day, hidden under clothing. However, many patients prefer to use their pumps during the night so that as not to interfere with daytime activities.

The regular use of DFO plays an extremely important part in keeping patients with thalassaemia in good health. But iron chelation therapy with DFO is difficult -- it is painful, time-consuming and hard to fit into daily life. It is therefore important that everybody involved in patient care - doctors, nurses, parents, and - most importantly - patients themselves, find ways to make treatment as easy as possible. Teenagers in particular may appreciate efforts to make treatment more discreet. Efforts should also be made to reduce to a minimum any local reactions or other complications associated with DFO (see later).

Other ways of administering DFO

In addition to the subcutaneous route of administering DFO described above, there are several other ways in which the drug can be used, each with some advantages and disadvantages.

Continuous 24-hour intravenous infusion

This method involves administering DFO through a vein. The technique can be life-saving in patients suffering

severe iron loading and associated cardiac complications, reducing the toxicity of iron in the body while it is being infused, and removing large quantities of iron more quickly than other methods. However, continuous intravenous infusion also carries significant risks, particularly of infection or blood clots caused by the in-dwelling line that provides access to the vein (see section below on Administering DFO by continuous intravenous infusion). The method should therefore only be used in exceptional cases, where patients exhibit:

- (i) severe iron overload - i.e. ferritin values persistently > 2500µg/l and/or liver iron concentration of > 15µg/g/dry weight of liver, established by a liver biopsy
- (ii) heart complications resulting from iron overload
- (iii) female patients planning a pregnancy, who have high serum ferritin levels and/or high liver iron concentration (LIC)
- (iv) continuous intravenous infusion may also be considered in patients requiring intensive removal of iron, irrespective of ferritin or LIC levels, for example before a bone marrow transplant or in patients with chronic active hepatitis C.

The continuous intravenous infusion of DFO involves delivery of 50mg/kg/day, continuously administered, seven days a week, by means of a special delivery system known as an in-dwelling catheter - a device placed inside the patient that provides access to a major vein.

This kind of catheter is relatively expensive, and patients using it require very close and careful medical supervision. Serious infections are the most frequent complication associated with this method of iron chelation, and sometimes blood clotting (thrombosis). Special drugs (anti-coagulants) can be introduced to help prevent clotting, and particular attention should be paid to keeping the skin around the catheter clean in order to prevent infections. Patients must be taught how to ensure the skin is kept clean, and reminded to immediately seek medical advice if they develop any adverse symptoms, including chills or fever, or sense any soreness or redness of the skin.



Intravenous 8-12 hour infusion

Intravenous 8-12 hour infusion of DFO, as opposed to continuous 24-hour intravenous infusion explained above, is another alternative to subcutaneous infusion, and may be used in cases of serious, localised, problems with subcutaneous infusions. The dose (40-50mg/kg/day), duration (8-12 hours) and frequency (more than 5 days a week) of infusion are generally the same as in subcutaneous infusion. However, this method is not as effective as 24-hour continuous intravenous infusion in cases of severe iron loading and associated cardiac complications.

It is important to note that the intravenous use of DFO should be introduced with caution and only where necessary; over the longer-term, the method may damage veins that are essential for blood transfusion therapy, and it carries a higher risk of infection.

Intravenous administration of desferrioxamine during blood transfusion

At some medical centres, DFO is introduced into the vein at the same time as the patient receives his/her blood transfusion. However, DFO must never be added directly to the blood being transfused to the patient, as it may contaminate the blood or cause a reaction. In general, no substance should be added to a patient's blood transfusion, unless it is scientifically proven that it cannot cause any harm.

In order to deliver DFO intravenously during a blood transfusion, the required amount of DFO is dissolved in a solution called "normal saline". A needle from the bag containing the DFO solution is then inserted into a y-connector with the blood bag attached, to be administered to the patient over a period of about 4 hours. If preferred, a pump may be used during the infusion. Often the time needed to effectively infuse a dose of DFO is longer than that required for a blood transfusion.

It is important to note that DFO administered only during blood transfusions -- i.e. once every 2-4 weeks -- has extremely limited effect. However, this may be the only option where DFO is in short supply. On the other hand, some centres administer DFO intravenously during patients' blood transfusion therapy in addition to their regular daily treatment, in an effort to improve the overall effectiveness of iron chelation treatment.

Intramuscular injection of DFO

When DFO was first introduced for the treatment of thalassaemia, it was administered by intramuscular injection. However, it has since been found that the method is not as effective as subcutaneous or intravenous infusions.

Intramuscular injections are still used in some cases - for example, in countries where desferrioxamine is prohibitively expensive and therefore only available in very small quantities, or where infusion pumps are not available. There is considerable evidence that patients are better off receiving at least some desferrioxamine, in whatever way, rather than none at all. Therefore if there is no alternative, DFO can be administered by intramuscular injection.

Another technique is to dissolve 500 mg in 5ml of distilled water, and to inject it into a muscle of the arm or leg. The dose is divided into two and administered twice each day - a technique recently shown by some investigators to be quite effective.

(b) Evaluating the effectiveness of DFO treatment

One way of evaluating the effectiveness of a patient's treatment regime is to estimate the amount of iron stored in the liver and other body tissues.

The liver is capable of storing a large amount of iron -- 70% or more of body iron stores, or about 20g. Any extra iron in the body is deposited in the liver, or other tissues if the liver is full. Iron stored in the liver and other tissues binds to the proteins ferritin and haemosiderin -- just as iron in the blood binds to the carrier protein transferrin. A small amount of ferritin escapes from the liver into the blood stream; a measure of the level of ferritin in the blood is used to determine iron load.

Normal levels of ferritin in the blood (or serum ferritin) are up to 250µg/l for men and between 10-120µg/l for women. 1µg of ferritin in the blood is considered to correspond to 8mg of iron in the body's stores. Patients with thalassaemia major with considerably higher levels of iron in the body are thus expected to have significantly higher levels of ferritin.

Although ferritin levels may be a reliable indicator of liver iron stores they are, however, less accurate in predicting iron load in other organs, such as the heart, or overall body iron load. In addition, other factors such as inflam-

mation, viral or bacterial infections, chronic liver disease, arthritis and vitamin C deficiency may affect serum ferritin levels, indicating higher or lower iron stores than are actually present.

Nonetheless, serum ferritin levels are considered the most practical indicator of possible iron-related complications. For example, some studies have shown that where ferritin levels are consistently below 2500µg/l over many years, a patient's risk of developing heart complications is low. The aim should therefore be to keep ferritin levels at between 1000-2000µg/l, and to check levels at least every three months in order to establish whether the patient's iron chelation treatment regime needs adjustment. It is also very important to monitor the appearance of any DFO-related toxicities, which occur when DFO is given at high doses and when ferritin levels fall below 1000µg/l.

Using ferritin levels to adjust doses of DFO

Ferritin levels can be used to establish the ideal dose of DFO for a given patient, by using the following equation known as the "therapeutic index" (TI):

$$TI = \frac{\text{mean daily dose (mg/kg)*}}{\text{serum ferritin (mg/l)}}$$

From TIF's "Guidelines for the Clinical management of Thalassaemia"

The target is to maintain the value of TI at under 0.025 at all times.

* The mean daily dose of DFO is calculated by multiplying the dose administered in each treatment by the total number of doses administered per week, divided by 7 - the number of days in a week.

Over recent years, a number of other tests have been developed that can reliably measure the amount of iron in the body. These tests are often carried out in conjunction with serum ferritin measurements in order to provide a more accurate picture of body iron loading, particularly in the liver and heart.

Liver Iron Concentration (LIC)

Measuring the concentration of iron in the liver involves removing cells from the liver tissue - a procedure known as a liver biopsy - and measuring the amount of iron they contain. A liver biopsy involves inserting a special

needle through the abdomen into the liver, usually under local anaesthetic and preferably using the guidance of ultrasound, to draw up a tiny portion of liver tissue. An accurate assessment of iron load depends in part on the amount (at least 1mg in dry weight) and quality (i.e. absence of cirrhosis or fibrosis) of the tissue specimen, and the expertise of medical staff carrying out the procedure is therefore extremely important. Although liver biopsy has a very low rate of complications when performed in a hospital setting with ultrasound guidance, it is nonetheless an invasive procedure that requires the full consent of patients and/or their parents/guardians.

Research has indicated that where liver iron levels are consistently maintained below 7mg/g of dry weight of liver, there is a small risk of heart or liver problems. Levels above 15mg/g of dry weight of liver may be associated with high risk of cardiac death. However, research is continuing to establish whether the above values of liver iron concentration reliably indicate low or high cardiac risk. As in the case of serum ferritin, scientists have questioned whether this technique accurately reflects total body iron load and, more particularly, deposits of iron on the heart. Recent research indicates that the most reliable measure of body iron load is obtained by multiplying liver iron concentration by a factor of 10.6mg/kg of body weight.

A liver biopsy can also provide information on the distribution of iron between liver cells such as hepatocytes and kupffer cells, as well as indicating inflammation or damage to the liver, such as fibrosis or cirrhosis.

New non-invasive methods of accurately assessing iron load have also been developed, such as SQUID -- Superconducting Quantum Interface Device. SQUID relies on the paramagnetic properties of iron to measure its concentration in the body. It uses a magnetic field that is about as strong as the magnet on a kitchen refrigerator. Prior to the procedure, with the assistance of an ultrasound and while lying comfortably on a bed the position of the liver is located within a few minutes.

The bed is then moved so that the body is properly positioned underneath the SQUID. The only part of the machine touching the body is a balloon filled with warm water, which is slowly placed on the upper abdomen. While the machine makes its measurements the patient has to hold his/her breath a few times for a few seconds each time. Patients younger than 6 years may require sedation in order to keep still. Patients weighing less than 10 kg or who are

4f SQUID (Liver iron measurement system)

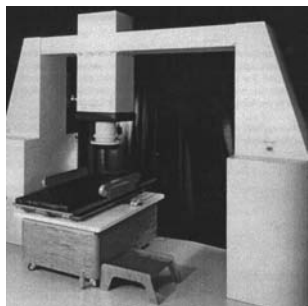

obese, are not considered as good candidates for this test. Unfortunately, the technique is very expensive, technologically demanding and is currently only available in five centres in Europe and North America. However, arrangements can be made for patients from other countries to visit SQUID centres abroad for assessment, should the treating physician consider it necessary.

Another method for measuring iron load in the liver still under investigation is Magnetic Resonance Imaging (MRI), which also relies on the paramagnetic properties of iron. Liver iron concentrations derived by this method (MRI, T2*) show reasonable and consistent correlation with those obtained by chemical analysis of liver biopsy samples. The potential advantage of this technology is that MRI is more widely available. MRI has also been shown to be a useful tool in evaluating iron load in the heart.

Iron content in the urine

Another - long-established -- method of estimating iron load is by measuring the iron content in urine over a 24-hour period, in order to assess the efficacy of chelation therapy with DFO. However, the clinical significance of this test is limited by the wide day-to-day variations in the DFO-induced secretion of iron in the urine.

Complications associated with DFO and how these may be addressed

Local skin reactions

The most common localised reactions include itching, redness, swelling, lumps, soreness, pain and general discomfort. The following tips may help reduce such reactions:

- (i) Avoid inserting the needle near important blood vessels or nerves, to minimise the risk of damage and/or bleeding.
- (ii) Check that the DFO has been dissolved in the correct volume of water (5ml of water for 500mg of DFO). If necessary, add extra water to further dilute the solution.
- (iii) Change the site chosen for injection. The abdomen is often the best site. Some patients prefer to use their upper arm or thigh. However, because localised reactions are likely to occur at any site over time, it is important to use different parts of the body. Over time, the long-term use of DFO may cause lumps to form around the injection site. This can be prevented by rotating sites or, in some but not all cases, by filling the plastic infusion tubing with a small amount of a chemical substance known as hyaluronidase, before setting up the pump.

- (iv) Pain may be reduced by applying topical anaesthetic creams such as Emla 30-60 minutes before starting DFO treatment. Swelling may be reduced by applying a warm compress on the affected area after DFO has been administered. For redness, soreness, itching or swelling, some doctors prescribe heparin cream or fuscor.
- (v) The rate of infusion should also be checked, as swelling can occur when DFO is administered too quickly.
- (vi) Doctors may also decide to give the patient an anti-histamine before the DFO infusion or, in severe cases, 5-10mg of hydrocortisone may be added to the DFO solution.
- (vii) There are a number of different infuser pumps available on the market, and patients may find that a different model better suits their needs. Balloon pumps are amongst the newest products. These are smaller, lighter and quieter than the older types. They also save time and can be more convenient for patients because the DFO solution used is pre-prepared by pharmacists, under sterile conditions. Because of these advantages, such pumps may also improve patients' compliance to iron chelation therapy. However, the high cost of these pumps limits their wider use.
- (viii) Patients may also wish to try different types of needles, discussing the pluses and minuses of different types with their doctor or nurse and other patients. Many patients prefer small, light needles called "butterfly" needles of 25 gauge or smaller, inserted at an angle of about 45 degrees to the skin surface. Other patients prefer small 'thumbtack' needles that are inserted vertically through the skin and fixed with a special tape.

If all of the above mentioned methods fail to relieve the patient of DFO-related reactions, the use of intravenous DFO therapy or an alternative chelator should be considered.

Severe allergy to DFO

Severe allergies to DFO are rare. Symptoms include feeling generally unwell, tingling, dizziness, general redness or swelling and difficulty breathing, occasionally also accompanied by fever or myalgia (muscle pain). The use of DFO should be discontinued if any of the above symptoms occur.

These general reactions tend to occur suddenly in patients who have just started treatment with DFO. However, patients who are on regular treatment will notice symptoms developing gradually. In any case, treatment for a severe allergy to DFO involves a process known as "desensitisation", in which patients are injected with a small amount of DFO together with hydrocortisone, gradually increasing it to a

Rotation of infusion sites

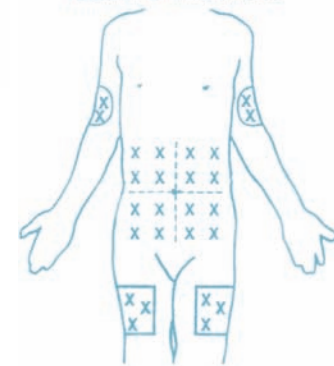

larger amount. This treatment is carried out under close medical supervision. It is often repeated until symptoms disappear, and is usually successful. However, if treatment is unsuccessful, patients should stop using DFO and consider using an alternative chelator, such as Deferiprone (see section on the use of Deferiprone).

Complications associated with incorrect doses of DFO

The following complications are mainly associated with high doses of DFO in younger patients and in patients with low serum ferritin (i.e. those that are less iron-loaded):

- Hearing problems (ototoxicity) - may include ringing in the ears and partial loss of hearing, particularly at high frequencies
- Eye problems (ocular toxicity)- may include night-blindness, blurred vision, decreased visual acuity, impairment of colour vision, cataract and other disturbances of the eye

DFO generally causes hearing and sight problems when it is administered at high doses, when molecules of DFO circulate in the blood without binding to iron. However, patients who have diabetes mellitus or who are being treated with psychotropic drugs may also be at risk of developing such complications, even if they are receiving correct doses of DFO, because these conditions increase the access of DFO to the central nervous system. Patients who develop hearing and/or sight problems are generally advised to stop the use of DFO for a time, restarting treatment at a lower dose once complications improve or disappear. If detected early, such complications are manageable and reversible. It is therefore important to regularly monitor patients receiving DFO, including full medical examinations with audiometric (ear) and ophthalmologic (eye) tests.

- Slowed growth and bone (skeletal) changes - High doses of DFO in patients with low ferritin levels may also delay growth rates. Risk factors include a young age for starting treatment (<3 years) and higher than recommended doses of DFO (>35mg/kg in very young children). Reducing dosage may rapidly return growth rates to levels seen before DFO treatment began. The effect of DFO on growth includes a disproportionately short trunk or arms, accompanied by damage to the bones or joints (metaphysical dysplasia) - a condition diagnosed by x-ray. Other factors such as iron load may affect growth in thalassaemia. However, it

is relatively easy to identify whether delays in growth rate are the result of high doses of DFO and such patients will not respond to treatment with growth hormones. Patients should receive regular checks for such changes, as they are irreversible.

- Infection with *Yersinia enterocolitica* - infections caused by the bacterium *Yersinia enterocolitica* are also commonly associated with the use of DFO. All living organisms need iron to grow, including bacteria, parasites and other pathogens. Most have special structures that enable them to acquire iron. However, *Yersinia* belongs to a family of bacteria that do not have their own means of obtaining iron, relying instead on receptors for ferrioxamine -- i.e. the compound formed after iron binds with DFO. DFO is a natural carrier of iron - something known as a siderophore (from the Greek sidero, meaning iron, and phoro, meaning carry) - and it therefore in effect supports the growth of *Yersinia* by providing it with iron. *Yersinia* infections can be extremely serious in iron-loaded patients, and the risk increases greatly where DFO is being administered. It is therefore important that *Yersinia* infections are quickly diagnosed and treated with appropriate antibiotics (see chapter on infections). Symptoms of infection include abdominal pain, diarrhoea, joint pains, fever or sore throat. If such symptoms appear, DFO treatment should be stopped until symptoms have disappeared and a full course of antibiotics has been completed. Serious infections caused by other bacteria such as *klebsiella* or fungi (mucormycosis) have been reported as possibly related to the use of DFO, but these infections are not as common as those caused by *Yersinia* species. Patients should be checked carefully, and should be constantly reminded to seek medical advice in the case of any unexplained fever. It may be necessary to stop the use of DFO until a diagnosis is clarified.

Rare complications associated with DFO

DFO should not be rapidly infused into the body, as it can cause flushing, low blood pressure (hypotension), rapid heart rate (tachycardia) and even shock. Kidney damage (renal impairment) and serious chest problems (Adult Respiratory Distress Syndrome) have been reported at very high intravenous doses of 10mg/kg/h or more.

4g Different parts of the brain have different jobs to do

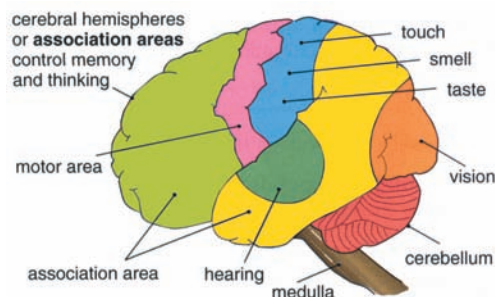



Pregnancy

Formal studies have not yet confirmed the safety of DFO during pregnancy. For the time being, the best advice to pregnant patients who need iron chelation is to avoid using DFO during the first three months of pregnancy. Pregnant patients with an extremely high iron load or serious heart problems have been treated with a low dose of DFO - 20-30mg/kg/day - in the later stages of pregnancy, without any adverse effects. DFO treatment can be resumed while breast-feeding.

Compliance with desferrioxamine therapy

The inconvenience and pain associated with using desferrioxamine means it is critically important that patients are provided with every support possible to adhere to treatment. Doctors, nurses and other professionals such as psychologists and social workers, as well as parents, must constantly offer patients of all ages hope and encouragement to continue with DFO therapy day in and day out. At the same time, no one must forget the immense will to live - and to live well - that each patient must constantly muster in order to persevere with such a demanding regime. Desferrioxamine treatment is difficult, time consuming, painful and expensive -- and must be adhered to over a lifetime. And although it is a life-saving therapy, DFO treatment does not give patients the sense of immediate benefit they feel, for example, after a blood transfusion. Instead, the benefits of iron chelation treatment are only apparent over the long term, in preventing or treating the many and serious complications of iron loading. Because the benefits of DFO therapy are not immediately apparent, many patients experience problems of iron loading, even in developed countries where desferrioxamine is easily available, because they find it difficult to comply with treatment. As patients enter their teenage and adult years, there is often increasing resistance to a treatment regime that can seem to disrupt everyday physical, professional, social and personal activities. So while in developing countries low patient survival rates are generally related to a lack of access to drugs and pumps, in developed countries the problem is more likely to be due to a lack of adherence to treatment. But whether the challenge is to provide patients with the drugs and pumps they need for treatment or to ensure that patients adhere to the treatment regime itself, patients will always need help and encouragement -- from national thalassaemia associations, medical staff, parents and other patients. TIF is also an important source of support, not least in helping



to persuade governments to back treatment and prevention programmes.

Other drugs for removing iron

Deferiprone (1,2 dimethyl-3-hydroxypyrid-4-one, L1) (4h)

Often referred to as the pill, Deferiprone or L1 is an oral chelator, swallowed like any other pill. Scientists disagreed over its early stages of development, investigational processes were regarded as incomplete and because of worries over its long-term safety and the absence of full studies looking at its effect on animals, the licensing of Deferiprone has proved controversial and has been delayed. Deferiprone was first licensed for use in 1995 in India, for use by patients who cannot use DFO because of toxicity, or inability to comply with recommended dosage. Similar permission was granted in Europe in 2000 under special conditions or exceptional circumstances policy that requires further studies. Deferiprone achieved full marketing authorisation in Europe in April 2002 after the pharmaceutical company responsible for its development (Apotex) fulfilled the specific obligations for additional studies. However, the US licensing authority the Food and Drug Administration (FDA), has not yet granted permission for its use. According to the license provided by the European Union, Deferiprone could be used as a second line drug, only for patients who are unable to use Desferrioxamine or in whom DFO therapy has proven ineffective. In the meantime, in Europe and the US, a number of controlled clinical trials have been conducted using deferiprone, aimed at assessing as best as possible its safety and efficiency. In some developing countries, mainly India, Deferiprone has been in use since long before its official registration in Europe and the USA. On many occasions its use has been outside clinical trials, partly because the alternative DFO- is so expensive and therefore beyond the reach of the great majority of patients, and partly because Deferiprone is sold relatively cheaply in India by local manufacturing companies.

4h L1 molecule

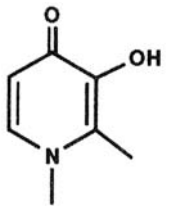

How deferiprone (L1) works

Three molecules of L1 bind with one atom of iron (bidentate) to form a complex. This complex is passed into the urine, not in stools, as is the case with Desferrioxamine. It is administered in the form of a tablet and because of the small size of the Deferiprone molecule it is rapidly absorbed, mainly by the stomach and reaches a high concentration in the blood 45-60 minutes after taking the drug. Deferiprone is metabolised to a glucuronide which loses its ability to chelate iron and is eliminated from the blood with a half-life of 47-137 minutes. It is therefore active in the blood longer than Desferrioxamine. Both Deferiprone and its metabolites are easily excreted in the urine. The level of iron chelation is related to the iron overload, but also to the administered dose of drug. The iron that is chelated by Deferiprone is delivered from the same pool, as that chelated by DFO, which is that iron which is not bound to the protein, transferrin (Non-Transferrin Bound Iron or NTBI) in the plasma. In addition, because of its small molecular size and other properties, Deferiprone may enter the cells and remove intracellular iron. The dose of 75-100mg/kg/day is in most cases sufficient to achieve a

negative iron balance in a portion of iron loaded thalassaemia patients.

Efficiency of Deferiprone

To check how well the drug is performing and to prevent the development of any of the unwanted effects associated with deferiprone (L1) described below, the following steps should be taken:

- (i) serum ferritin should be measured once every 3 months
- (ii) full blood count should be established weekly
- (iii) 24-hour urine examination should be carried out once every 3 months. This is particularly useful in the case of L1 because, unlike desferrioxamine, almost all iron removed by L1 passes into the urine
- (iv) biochemical analysis - liver function test to be performed monthly and
- (v) zinc levels should be assessed 3 - 6 monthly

The treating physician who knows best the clinical condition of the patient decides on the frequency and the range of the monitoring tests required.

Where possible liver biopsy (a), the use of the SQUID (b) and the MRI (c) could provide more accurate information on the iron content in liver (a+b) and heart tissue (c).

Substantial data concerning the effectiveness and safety of deferiprone have accumulated over the last 15 years, and many scientists involved in the treatment of thalassaemia have now begun to pool and analyse all available information on the use of the drug. Review of these data has shown that (6):

- Treatment with deferiprone reduces serum ferritin levels and iron concentrations in some patients. The drug can be given safely with careful monitoring for 4 years or more. Data have also shown that the amount of iron passed out in the urine can increase and the serum ferritin levels can be decreased further by:
 - increasing the dose of deferiprone to above 75 mg/kg of body weight per day, the dose commonly used, and
 - combining deferiprone treatment with desferrioxamine

However all scientists involved in the treatment of thalassaemia agree that formal, long term studies are needed to investigate better the toxicity of the drug, both when used at higher doses and when combined with DFO. Gradually, a much clearer picture as to how and when the drug can be used as well as to the types of patients most likely to benefit from its use, will emerge. Until then every effort should be made both by the physician and the patient to improve compliance to DFO therapy and L1 to be used following strong medical indication.

Unfortunately the price of both DFO and deferiprone limits their appropriate use in the majority of the developing countries.

Adverse effects of L1

The most serious unwanted effect of L1 is a reduction in the number of white blood cells, particularly neutrophils, which play an important role in protecting the body against infection.

A moderate reduction in the level of neutrophils (500-1500/mm³) is known as neutropenia, while a severe reduction (<500/mm³) is known

as agranulocytosis. According to a number of studies assessing the use of L1, neutropenia is more common, while agranulocytosis occurs in a significantly smaller number of cases. However, both can be reversed if patients stop using deferiprone. It is therefore essential that any patient using L1 is assessed for total white cell count and the number and percentage of different types of white cells (differential white cell count) every week. Patients should be checked more frequently if they show any sign of infection. At the first sign of fever, sore throat or any other indication of infection, the patient should immediately stop using deferiprone, a full blood check should be carried out and any course of antibiotics prescribed completed. In most cases, the white cell count returns to normal and deferiprone therapy can be started again. However, it is not advisable to restart treatment with L1 until the total white cell count is equal to or greater than 3,000/mm³, the total number of neutrophils equal to or greater than 1,000/mm³ and the platelet number equal to or greater than 100,000/mm³. Given the drug's adverse effects, careful consideration should be given before prescribing L1 to patients with thalassaemia major infected with hepatitis B and/or C who are candidates for interferon treatment.

Other side effects of deferiprone

(i) A number of patients using L1 experience pain and swelling of the joints - usually in the knees, ankles, elbows, hips and lower back, as well as stiffness and difficulties in movement. Swelling of the joints has been reported in patients with high serum ferritin and/or those taking high doses of L1 (greater than 75mg/kg/day). Although the cause of development of this side effect is not clearly understood it is thought that this may be the result of inflammation that may be caused by the iron transferred by L1 from other pools to the joints. A reduction in dose or stopping L1 altogether may reverse this effect. Joint pain can be managed through painkillers (analgesics). Unless analgesics and/or reducing doses of L1 fail to improve these symptoms, the patient may be required to stop using the drug altogether. Also, if joint pains are accompanied by a swelling of the joints, patients are normally advised to stop using the drug. The use of L1 may then begin again, although at a smaller dose and under close monitoring as there is a significant risk of the patient again developing joint pain and swelling.

(ii) Gastrointestinal problems such as nausea, dizziness, vomiting, diarrhoea and pain in the abdomen occur in some patients using L1. Symptoms are usually mild and may not require treatment. Drugs (antacids, antiemetics) will generally reduce symptoms. In addition, taking L1 with food may help reduce nausea.

(iii) Zinc deficiency may develop in patients using deferiprone, as the drug can bind to other metals in addition to iron, including zinc - a substance the body requires for a number of functions, including the

growth and development of the skin. A reduction in levels of zinc is noted in some of the patients, with a higher risk in patients with diabetes. The problem can be corrected by giving zinc supplements to patients taking L1. It may also be necessary to ensure that other metals needed by the body to carry out its regular functions are not inadvertently removed by L1 treatment. The target of iron chelation in thalassaemia major is to remove only the toxic, harmful, excess iron, leaving other, useful metals in the body.

(iv) Liver toxicity -- increased levels of liver function tests (ALT) reported in a multicentre study, where generally transient and occurred more commonly in patients with Hepatitis C. Fluctuating liver function tests have required a small proportion of patients to stop using L1. One paper suggests that liver fibrosis may progress more rapidly in patients using L1 than those using DFO, although observations of a number of different studies (not designed for this purpose) and a recent evaluation by 3 independent pathologists of serial liver biopsies from 56 patients with thalassaemia participating in a multicentre study in Italy, have so far failed to report progression of fibrosis. However, prospective trials should be undertaken to resolve this issue.

Unwanted effects caused treatment with L1 to be stopped in 13%-30% in various studies.

Using Deferiprone in combination with DFO

In the last few years, several medical centres are using various combinations of Deferiprone with DFO, in order to achieve more effective chelation. The idea is that these two chelating agents may possibly bind iron from different sources, due to the different mechanisms of chelating iron, based on the physico-chemical and pharmacological properties, and in this context it appears that the action of one is complemented by the other. One drug transfers iron from the cells to the plasma, where it is received and bound by the second chelating agent which removes it from the organism. This mechanism is widely known as the "Shuttle Effect" (4h).

As a method of treatment, combination therapy is still under study. However, results of studies or clinical use or observations from the use of such combinations show that in patients who are either heavily iron-overloaded or have an iron overload in the heart (based on the MRI T2* results), combination therapy is quite effective. Moreover, the results demonstrate that, in addition, there may be an improvement in the cardiac function (improvement of the LVEF of T2* and the correction of arrhythmias). Therefore, in this context, combination therapy may improve patients survival, an issue that has been verified by recent survival studies published.

4j Shuttle effect



New Oral Drug for removal of excess iron-Deferasirox

In recent years, several other chelating agents are at the research stage, with particular emphasis given to oral iron-binding drugs. The only one of these that has completed the clinical trial stage is ICL670 (4h), otherwise known as Deferasirox (or under the commercial name Exjade). The manufacturing company is the same one that manufactures Desferrioxamine. The safety, the effectiveness and the appropriate dosage for humans have been established, after the completion of clinical trials, which had the biggest programme that has ever been created for a chelating agent, more than 1,000 patients participated, and there is 5 years experience up to the official approval. Deferasirox has been registered in more than 70 countries across the world. Deferasirox is available to patients, without any prescription restrictions, according to its approved indications, as from the first quarter of 2007. To date, it is estimated that about 15,000 patients worldwide, are treated with Deferasirox.

4k ICL670A molecule

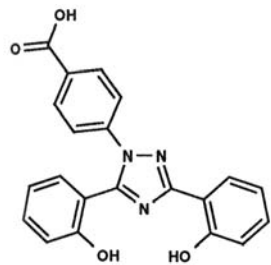

Deferasirox is prescribed for the treatment of chronic iron overload to:

- a. Multi-transfused patients with β -thalassaemia from the age of 2 years old, according to FDA approval and from the age of 6 according to the EMEA approval;
- b. (i) Patients suffering from other anaemias and (ii) patients with β -thalassaemia who are not frequently transfused or when iron-chelation therapy with Desferrioxamine is contraindicated or is considered to be insufficient.

The decision to start iron chelation therapy with Deferasirox is up to the best judgement of the treating physician. With doses between 20-30mg/kg/day, Deferasirox removes iron from the liver with the same effectiveness that Desferrioxamine produces when used at doses between 35-40mg/kg/day. Using Deferasirox in combination with any other chelating agent is at present contraindicated, as there are no studies which can provide information on safety and effectiveness for such a combination. Deferasirox can provide a 24-hour protection to the patient with just a single daily dose, orally. Before starting iron chelation treatment with Deferasirox, the serum ferritin, kidney, liver, as well as ocular and auditory functions should be checked and monitored throughout the course of the treatment. This is in accordance to the guidelines for using this drug from the manufacturing company.

Ways of Administration:

Deferasirox is available in the form of a tablet which is dissolved in either water or in apple or orange juice. It should be taken at least 30 minutes prior to a meal, as soon as it is dissolved. It should not be swallowed undissolved or powdered. It is administered at a dose of 20-30mg/kg once daily.

How does Deferasirox function?

Deferasirox, is a tridentate chelator which binds the ferric form of Iron (Fe^{3+}) and thus two molecules of this substance are needed to bind one atom of Iron (Fe^{3+}). The complex that is created between the Iron molecule and that of Deferasirox is removed almost exclusively via the faeces. The drug, which is slowly metabolised in the liver, remains in the blood plasma for many hours (half-life between 9-11 hours). Therefore, one daily dose can be effective over a 24hour period.

Effectiveness:

According to published data, a dose of 20mg/kg stabilises the serum ferritin levels at about 2,000 $\mu\text{g}/\text{l}$, while the higher dose of 30mg/kg can reduce the ferritin level by up to 1,000 $\mu\text{g}/\text{l}$ over one year of continuous administration. Liver biopsy has shown the effectiveness of the drug in removing iron from the liver, especially at the higher dose (30mg/kg). In addition, relating to the drug's ability to remove iron from the heart, experiments using cultured cells, have indicated that the drug has the ability to enter the heart cells and remove iron. However, up until the time of writing, clinical experiments have not completely confirmed these findings. Further and more extensive studies are expected to shed more light on this very important issue.

Adverse Effects:

Stomach symptoms and diarrhoea can be experienced within the first week of drug administration. These symptoms soon subside and rarely the doctor has to reduce the dose. Transient fever and common cold symptoms have also been reported.

About 10% of patients experience an itchy skin rash which can either be widespread or found localised in the palms or soles. In most patients this skin rash appears within the first 15 days of administration, and usually subsides so that there is no need to either stop or reduce the dose, except very rarely.

In addition, in a percentage of patients an increase in the serum creatinine levels is observed, creatinine being a protein that is closely associated with kidney function. In most of these cases the observed increase is dosage related. However, in only a very small number of patients, does the level of creatinine exceed the upper limit of the normal range. In the majority of patients the creatinine level returns to within the normal range, upon reducing the dosage. That is to say, in the majority of patients this finding should not create any anxiety, but it does suggest the need for frequent monitoring of kidney function (monthly). In addition, the drug should not be given to patients with already established or developing kidney dysfunction.

Liver enzyme (elevated transaminase levels) disturbances are rarely

observed. Here again, if there is a pre-existing liver dysfunction, the treating physicians should decide whether this chelating agent should still be prescribed. Monthly liver enzyme monitoring is recommended.

Auditory and ocular disorders have also been reported in a small number of patients. However, as with Desferrioxamine, a yearly auditory and ocular check-up is recommended.

Contra-indications:

Simultaneous use of other drugs with Deferasirox

Drugs like Rifampicin, or phenobarbitone or phenytoin can cause a reduction in the concentration of the drug in the blood. This reduces the effectiveness of the drug. If any of these drugs have to be administered, this should only be done under the guidance of the treating physician.

The simultaneous administration of Deferasirox and Vitamin C has not yet been studied. However, no adverse effects have been reported when 200mg of Vitamin C are taken on a daily basis. Moreover, the simultaneous intake of antacids containing aluminium, such as aluminium hydroxide (Maalox and Gaviscon) should be avoided, as this combination has not been studied. In case a patient needs to take such an antacid, it is recommended that this should be taken some hours after Deferasirox has been administered.

Pregnancy and concomitant use of Deferasirox

Due to the lack of data, it is recommended that Deferasirox should not be used during pregnancy, unless it is judged absolutely vital by the treating physicians and under close monitoring.

Chapter 5

Medical problems associated with thalassaemia and its treatment

The treatment of thalassaemia major has improved dramatically over the last two decades, leading to a sharp increase in survival rates and significant improvements in patients' quality of life - particularly those living in the West. Nonetheless, patients with thalassaemia major may suffer a number of medical problems, some of which are due to the disease itself, while others are the result of inappropriate or poor quality treatment, including inappropriate blood transfusion therapy, lack of blood safety and sub-optimal use of DFO.

Hypersplenism

Many patients with thalassaemia major experience problems of the spleen - a soft, purplish organ about the size of a fist, located on the left-hand side just below the diaphragm, under the ribs (see 5a). A normal spleen contains 20-30ml of red blood cells. However, in patients with persistent moderate to severe anaemia as a result of inappropriate blood transfusion, the spleen may hold a litre (1000ml) or more of blood. This is because the spleen produces extra red blood cells in a process known as extra medullary erythropoiesis - i.e. the synthesis of red blood cells outside the normal site of production, the bone marrow - in an effort to help the body overcome anaemia.

The spleen performs several important functions, including protecting the body from infection by filtering the blood to remove any invading microbes, bacteria and parasites (see 5b). The spleen is also responsible for removing red blood cells at the end of their lifecycle from the circulation, breaking them down to release the globin and iron from their haemoglobin to be reused in making new cells. In patients with thalassaemia major, however, this recycling process does not work properly. Instead the iron is deposited in the spleen or released into the blood stream and transferred back to the spleen. In addition, most of the red blood cells patients with thalassaemia produce are abnormal in shape and so get stuck in the

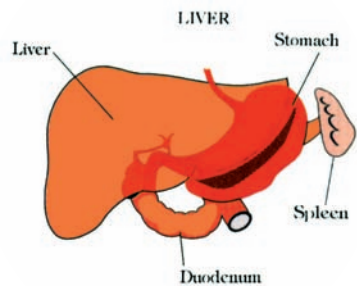

spleen. As a result, the spleen grows larger and larger, often forcing the abdomen to grow along with it.

In an effort to cope with the increased demands made on it, the spleen often becomes hyperactive - a condition known as hypersplenism - and in the process also destroys the normal red blood cells the patient receives from blood transfusions. As a result, the patient requires more blood at each transfusion, but the transfusions fail to have an effect on the anaemia. A hyperactive spleen may also destroy other components of the blood, such as white blood cells and thrombocytes.

Hypersplenism cannot be corrected. Therefore, once it is confirmed that the spleen is performing in a way that is harmful to the body, as described above, it must be surgically removed - a procedure known as a splenectomy. A splenectomy will not cure thalassaemia - it simply solves the specific problems that result from an enlarged spleen.

A decision to remove the spleen should be taken after careful consideration of a number of medical factors, including the following, most important, criteria:

- (i) an oversized spleen - usually more than 6cm in length - and resulting in discomfort
- (ii) an increasing amount of blood is required to transfuse a patient with no other medical problems - i.e. when the amount of blood required increases 1.5 times or more than 200-220ml/kg/year of packed red cells are required to maintain average haemoglobin levels
- (iii) the age of the patient, who should be over 5 years old. As previously mentioned, the spleen plays an important role in defending the body against infection. Removing the spleen therefore increases the risk of serious infection. In children under 5, this risk is particularly high as their immune system is not yet mature.

Splenectomy is now considered a relatively straightforward surgical procedure and does not involve the considerable risk seen in the past. Techniques involving a partial splenectomy or embolisation have also been developed, in an effort to preserve the organ's immune functions.

Splenectomy and infections

The main concern after splenectomy is the risk of developing serious infections. Many bacteria pose greater risks than normal to a splenectomised patient, causing serious

5b phagocyte filled with bacteria

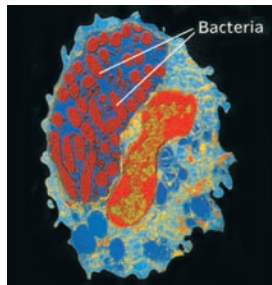

a neutrophil that detected the bacteria nearby

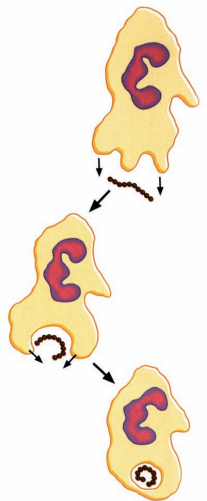

to fatal infections. Such bacteria most frequently include those that cause streptococcal infections and meningitides.

The risk of infection is very high if the patient is under the age of 5 and extremely high under the age of 2. The patient remains at higher risk of infection throughout their life after a splenectomy, with a particularly high risk for 1-4 years after surgery.

There are three techniques aimed at preventing or minimising the risk of infection in patients who undergo a splenectomy:

- (1) Immunoprophylaxis: Immunization with the pneumococcal, haemophilus influenza and meningococcal vaccines. Vaccinations normally begin about two weeks before surgery and are repeated after surgery according to recommended guidelines.
- (2) Chemoprophylaxis: Antibiotics - normally oral penicillin - are administered, 125mg b.i.d. for children under 2 and 250mg b.i.d. for children over 2. Alternative antibiotics may be prescribed if the patient cannot take penicillin. However, the duration of use varies greatly from case to case. For example, some doctors advise splenectomised patients to take antibiotics for life and others until the age of 18, while others advise taking them for just two years after a splenectomy. In any case, patients will require regular evaluation to ensure risks are kept to a minimum.
- (3) Education: Educating patients and parents about the risks of any infection and encouraging them to be alert to any signs of possible infection e.g. fever, malaise or muscle pain, is extremely important. Patients and parents who are planning to travel should also be aware of the different infectious diseases that may be prevalent in other parts of the world.
- (4) Attention to raised platelet count: An increased platelet count can occur after splenectomy - i.e. above 800,000/mm³. This condition can be managed by administering 50-100mg aspirin/day until the platelet count returns to normal.

Overall, the best approach is to avoid problems of the spleen altogether by administering safe and appropriately processed blood as soon as a diagnosis of thalassaemia major is confirmed, keeping Hb levels above 9-10g/dl. In

this way, the development of an enlarged spleen may be delayed and even prevented, avoiding the need for a splenectomy. In addition, maintaining the spleen at around its normal size helps ensure the efficiency of blood transfusions.

Heart and endocrine complications

Thalassaemia major patients often experience problems with the heart, liver and endocrine glands, all of which are usually associated with iron overload. However, unlike heart problems (see below), patients receiving insufficient or no blood transfusions rarely develop liver and endocrine problems, partly because these conditions occur in highly transfused patients on poor iron chelation regimes, and partly because insufficiently transfused patients will not usually live long enough for the condition to develop.

Consequences of excess iron

Heart	Biventricular failure Arrhythmia
Pituitary	Hypogonadotropic-hypogonadism Osteoporosis
Endocrine gland	Diabetes Hypothyroid hypoparathyroid
Liver	Fibrosis Cirrhosis, especially if hepatitis C active

Heart complications

Heart complications are very common in patients on no or low transfusion schemes. These patients experience chronic anaemia, as well as gradual deposits of iron on the heart - both of which place considerable strain on the heart and can cause heart failure. The majority of untransfused or low transfused patients do not reach the second decade of life, with heart disease the main cause of death.

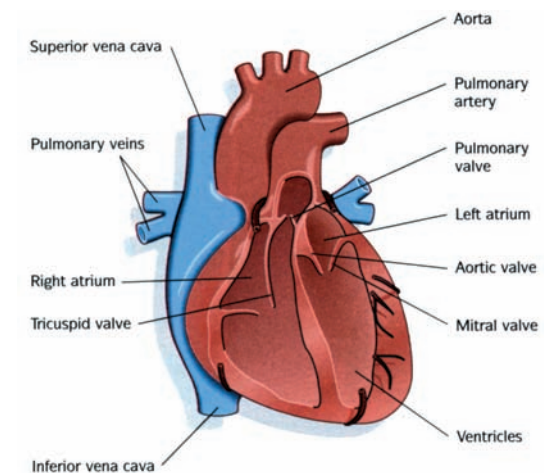

Patients who are well transfused but do not receive effective iron chelation, either because they are unwilling to use DFO as regularly as recommended or because DFO is not easily available (or is too expensive), may experience heart problems as a result of iron overload. As previously described, blood transfusions introduce a significant additional amount of iron into the body, which - unless removed - is deposited on all the organs, including the heart. The extra iron deposited on the heart gradually interferes with its normal function and makes it less able to withstand infection or other illness. Eventually, the heart muscle may be weakened, limiting the heart's ability to pump blood around the body (see 5c). Patients that are well transfused but not adequately chelated commonly die of heart problems in their 20s.

There are a number of different parts of the heart that may be affected by iron load, such as the pericardium, myocardium, valves or conduction tissue. Each of these parts has a different function that can be affected by iron overload, producing different symptoms, including disturbed heart beat (arrhythmia), impaired relaxation of the heart muscle (diastolic dysfunction), impaired pumping performance (systolic dysfunction), accumulation of fluid in the tissues (pleural effusion, pericardial effusion, ascites, peripheral oedema) and other signs of cardiac failure.

Equally, however, serious cardiac disease as a result of iron overload may occur in the absence of any symptoms. It is therefore important for patients to undergo thorough, regular check-ups with a cardiologist from the early teens when they are free of complaints, in order to promptly identify symptoms such as palpitations, syncope (such as fainting), shortness of breath, pain just above the stomach, tiring easily during exercise or swelling around the ankles or other parts of the body, whenever they may occur. Once such symptoms are identified, heart disease may have already have progressed to a serious stage. However, even when heart function has been severely affected, intensified chelation therapy can restore the heart to normal.

Monitoring heart function

Thalassaemia patients should undergo a full cardiological assessment at least once a year - possibly more if prob-

lems are identified. The following tests are essential elements of an annual check up:

- physical examination and history (including description of any symptoms)
- chest x-ray. Although more informative techniques are now available to cardiologists, chest x-rays remain a useful tool where more sophisticated methods are not available, providing useful information on heart size and the lungs, as well as warning of any extramedullary haemopoietic masses that may be forming.
- ECG (electrocardiogram) combined with exercise, a test that will show up any tendency to arrhythmia or poor functioning of the heart chambers (ventricles)
- 24-hour ECG. This involves attaching the patient to a special monitor (a Holter) for 24 hours, allowing any abnormalities of the heart rhythm that may be missed by a short ECG recording to be identified.
- Echocardiogram. This is a very useful tool, indicating the size of the heart chambers and how well each part of the heart is functioning.
- MUGA scan. This is a radioisotope examination that provides additional information on heart function. The examination may be carried out while the patient is at rest, although a more accurate result is achieved if it is carried out while the patient exercises.

To prevent or manage heart disease in patients with thalassaemia major, a number of measures should be taken:

- Patients without cardiac complications should be provided with enough blood to maintain haemoglobin at close to recommended levels -- i.e. 9.5-10g/dl.
- Patients with cardiac complications should receive enough blood to maintain pre-transfusion haemoglobin levels at 10-11g/dl, to ensure good oxygenation of the cardiac muscle. In order to avoid overloading the heart, it is recommended that patients receive frequent, small transfusions of concentrated red blood cells. In cases of established heart failure, a diuretic may be given with each transfusion, at the doctor's discretion.
- Patients with cardiac disease or high iron loads should follow a very intensive iron chelation programme,

5c A summary of the homeostatic control of the heart.

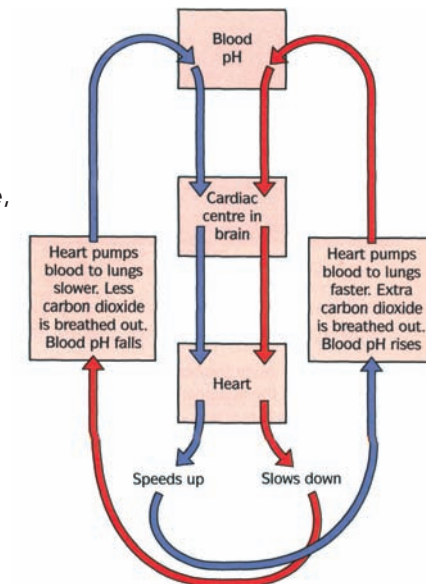

possibly including continuous 24-hour infusion of desferrioxamine (either subcutaneous or intravenous using an in-dwelling catheter), usually at doses of 50-60mg/kg/day. This treatment regime should prevent any further damage to the heart muscle by excess iron, as well as protecting it from continuing attack by free radicals.

- Recent studies have also indicated that using desferrioxamine and deferiprone together (combination therapy) may more rapidly reduce cardiac iron load and thus improve cardiac function.

It is now well established that intensive chelation can reverse even severe heart disease in thalassaemia. However, it is much better to use chelation therapy to prevent heart disease occurring at all rather than starting once cardiac complications have already taken hold. Assessing iron concentration in heart tissue has been difficult. However, recent developments in the use of MRI indicate the technique may be an extremely promising means of making direct measurements of heart iron content. In short, the treatment of cardiac complications in thalassaemia major depends on intensified treatments to remove accumulated tissue iron, in addition to conventional drugs used to support failing cardiac muscle, such as:

- drugs that improve the pumping action of the heart. These are mainly from a group of drugs known as Angiotensin Converting Enzyme or ACE inhibitors.
 - diuretics that relieve shortness of breath in patients with congestive heart failure
 - drugs that correct irregularities in heart rhythm (anti-arrhythmic agents)
- Other diseases such as the endocrinological complications of hypothyroidism and hypoparathyroidism or a lack of vitamin C may also cause disease of the heart muscle. However, the condition can usually be reversed by treating the underlying cause -- i.e. the endocrine problem or the lack of vitamin C.

Endocrine complications

The endocrine system consists of several glands -- pituitary, thyroid, parathyroids, adrenals and pancreatic beta cell, as well as testes in males and ovaries in females.

These glands are responsible for producing and secreting hormones: they are also vulnerable to the toxic effects of excess iron deposited in their cells, which interferes with the production of hormones. Complications of the endocrine system are therefore a common problem in thalassaemia patients, even those who began proper chelation therapy early in their lives. Endocrine disorders include slowed growth and delayed puberty, diabetes, hypothyroidism, hypoparathyroidism and, in adults, failure of sexual functions.

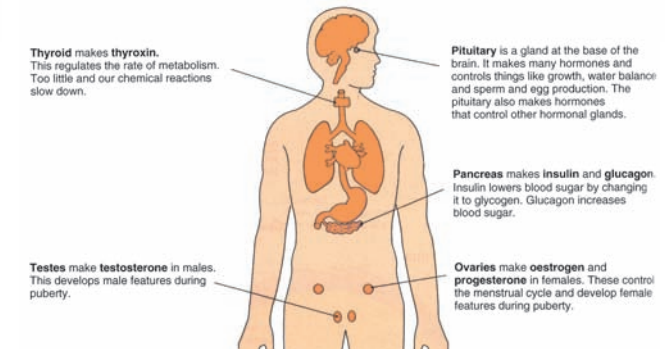

Growth

Around 30-50% of patients with thalassaemia major are affected by disturbed growth, which may be due to a number of factors. Chronic anaemia, hypersplenism, iron overload, desferrioxamine toxicity, hypothyroidism, delayed puberty, hypogonadism and chronic liver disease all negatively affect growth, as well as deficiencies in growth hormone or resistance to its action, genetic predisposition, poor nutrition and emotional stress.

In countries where patients do not receive adequate treatment, chronic anaemia and inadequate nutrition are the main causes of growth failure, whereas in countries where patients are well transfused but show poor compliance to chelation treatment, iron overload remains the major cause of poor growth. However, in well-transfused and well-chelated patients, high doses of desferrioxamine may cause toxicity at the bone level, which ultimately delays growth.

The effective treatment of growth disorders depends on an accurate assessment of their cause. Diagnosis must therefore involve careful and regular clinical and laboratory tests from early childhood into adolescence. Evaluations of the secretion of growth hormone and its

Endocrine gland	Hormones produced	What the hormone does
Thyroid gland	Thyroxine	Controls growth and metabolic rate
Parathyroid gland	Parathyroid hormone	Controls blood calcium
Islets of Langerhans	Insulin	Controls blood sugar
Islets of Langerhans	Glucagon	Controls blood sugar
Adrenal body	Aldosterone	Controls blood sodium chloride
Adrenal body	Adrenaline	Prepares the body for stress
Testes	Testosterone	Secondary sexual characteristics in male
Ovaries	Oestrogen	Secondary sexual characteristics in female
Ovaries	Progesterone	Prepares uterus for fetus
Pituitary gland	Trophic hormones	Control other ductless glands, eg gonads and thyroid
Pituitary gland	Prolactin	Milk production in mammary glands
Pituitary gland	Growth hormone	Controls growth

5d Incidence (%) of endocrine complications in thalassaemia major

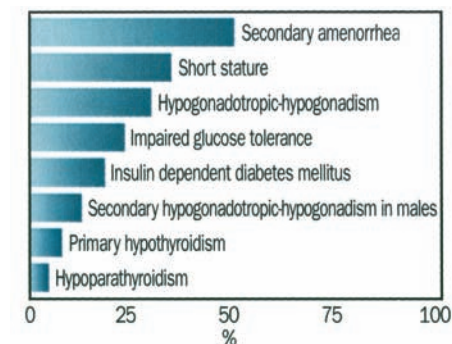

(from De Sanctis et al 1995 multicentre study on endocrine complications in thalassaemia major. Clin Endocrinol 42:581-86)

subsequent action have yielded conflicting results, limiting the therapeutic use of growth hormone to those patients proven to have growth hormone deficiency and to show satisfactory response to treatment.

Delayed puberty and hypogonadism

At the onset of puberty, the hypothalamus - the portion of the brain nearest the pituitary gland - starts to secrete a hormone called gonadotrophin-releasing hormone (GnRH), which stimulates the pituitary gland to produce and secrete the gonadotrophins: the follicle stimulating hormone (FSH) and the leutinising hormone (LH). These are the hormones that act on the sex glands - the testes in males and the ovaries in females, so that they grow and begin to produce and secrete sex hormones - testosterone in boys and estadiol and progesterone in girls. These sex hormones are carried around the body, controlling the development of male and female sex organs and reproductive capacity. The pituitary gland, in which FSH and LH are produced, is particularly sensitive to the harmful effects of free iron, reducing its ability to produce those hormones.

Delayed puberty and hypogonadism are the most common iron-related endocrinological complications reported in almost all studies from a range of countries. Delayed puberty is defined as the complete absence of sexual development: breast enlargement in girls by the age of 13 years and increase of testicular size in boys by the age of 14 years. If no pubertal sign is seen by the age of 16 years, the patient is diagnosed as having hypogonadism -- in boys, the testes and the penis remain small in size, while in girls, breasts have not developed and the onset of the menstrual cycle has not occurred (primary amenorrhoea). This condition often causes important psychological stress.

The effective treatment of delayed puberty depends on an accurate assessment of the cause. Excess body iron can interfere with any of the stages of sexual development described above, affecting each person differently. Each case therefore requires careful diagnosis, based on detailed clinical examination. Appropriate iron chelation treatment plays a vital role in improving such complications. In addition, sex steroids (testosterone in boys and oestrogen in girls) are prescribed, in order to promote

Male	Facial hair (beard) develops Voice deepens Shoulders become broader Muscles develop Growth of hair in armpits and possibly on chest Growth of pubic hair
Female	Breasts grow Uneven distribution of fat under the skin changes body proportions Growth of hair in armpits Hips broaden Growth of pubic hair

linear growth and the development of sexual characteristics, and to increase the size of the sex organs. The endocrine system remains vulnerable to the effects of excess iron even if the patient experiences a normal puberty, as iron that builds up in the body later on can still cause damage to the pituitary or sex glands. In such cases, a female's menstrual cycle may stop (secondary amenorrhoea), while males may experience secondary impotence, decreased semen production and infertility.

Hypothyroidism

The thyroid gland is located in the neck and plays an important role in ensuring the normal development of the brain in the first years of life, and later in overall growth and development. Thyroxin, the hormone produced and released by the thyroid gland, contributes to the overall energy level and metabolism of an individual. However, when iron is deposited in the gland its ability to produce this hormone is reduced, resulting in a condition known as primary hypothyroidism.

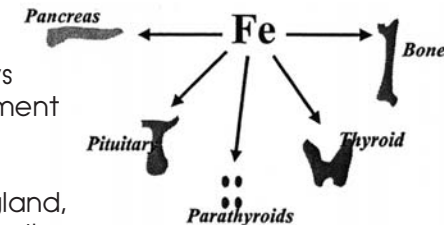

Patients suffering from primary hypothyroidism may feel extremely cold and sleepy and often show mental and physical sluggishness with weight gain. Severe damage to the thyroid caused by iron deposits may also affect the function of the heart. However, the condition is not always accompanied by clinical signs and is therefore best diagnosed by regular laboratory tests (TSH, T3 and T4), which are performed annually after the age of 10 years. When laboratory tests confirm the presence of hypothyroidism (elevated TSH with normal or decreased Free T4), then thyroxin is given therapeutically -- whether or not the patient has developed clinical symptoms.

Hypoparathyroidism

There are four parathyroid glands, which are attached to the thyroid gland. The main function of these glands is to control the level of calcium in the body through parathormone, which is the hormone that they produce and secrete. Iron overload and/or anaemia affect the function of the parathyroids, resulting in hypoparathyroidism. This causes the level of calcium in the body to fall - a condition referred to as hypocalcaemia, which in turn has a knock-on effect on the levels of another essential chemical element, phosphorous.

Calcium and phosphorous levels are related to a number of clinical symptoms. Low levels of calcium can cause tingling and prickling feelings in the arms and legs, sometimes leading to cramps and muscle spasms. The appearance of generalised seizures and cardiac dysfunction may be a late manifestation. A laboratory investigation of serum calcium, phosphorous and parathormone levels can help in reaching a diagnosis. The therapeutic administration of calcium and vitamin D corrects the metabolic abnormality. In the rare case of serious spasms with significant hypocalcaemia, calcium may be given intravenously.

Diabetes mellitus

A common complication linked to chronic iron overload, chronic liver disease, viral infections and genetic factors is a disturbance in glucose balance, which ultimately results in the development of diabetes. Diabetes mellitus is defined as the presence of hyperglycaemia (fasting blood sugar > 126 mg/dl or random blood sugar > 200 mg/dl), whereas glucose intolerance is defined as the inability of the pancreatic beta cell to secrete the appropriate amount of insulin in response to glucose administration. Nearly half of all patients with thalassaemia major patients suffer from glucose intolerance, while 10-30% develop diabetes mellitus at some time in their life. A family history of diabetes, particularly amongst first-degree relatives - usually a mother or father - indicates an increased risk of developing diabetes.

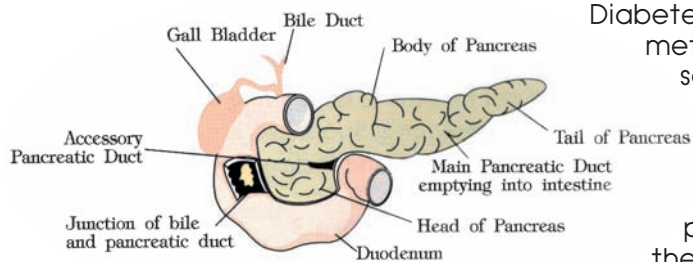
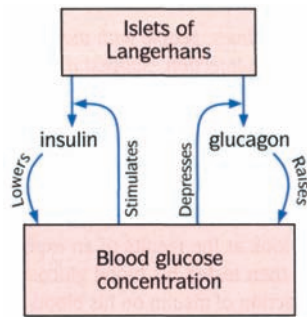

Diabetes occurs when the body's metabolism of glucose is disrupted so that glucose cannot enter the cells to provide them with the energy they require to function. The organ responsible for the metabolism of glucose is the pancreas, which is located near the stomach and which, through the beta cells, produces insulin, the hormone used to metabolise sugar. Iron can damage these special beta cells, and so the body's ability to utilise sugar is reduced and sugar accumulates in the blood.

Patients with a milder form of diabetes - referred to as glucose intolerance - show no clinical symptoms and their condition can only be diagnosed with a laboratory test.

Research has shown that thalassaemia patients go through a stage of glucose intolerance before developing diabetes, during which the production of insulin actually increases as a response to its impaired action. This stage, called insulin resistance, requires careful monitoring, with the patient following an appropriate diet and losing weight where necessary, as well as more intensive iron chelation.

Glucose intolerance and diabetes mellitus are diagnosed through laboratory tests of blood glucose level at various stages before and after eating. For example, a blood glucose level equal to or above 7mmol/l (or 126mg/dl) in the morning before any food or drink is consumed is diagnostic of diabetes. A blood glucose level above 11mmol/l (200mg/dl) two hours after glucose administration is also diagnostic of diabetes. A blood glucose level of between 8-11mmol (140-200 mg/dl) two hours after ingestion of 75g of glucose called impaired glucose tolerance test, indicates glucose intolerance. The glucose tolerance test is performed once a year in all patients over 10 years of age.

In the case of diabetes mellitus, the more severe form of the disease, insulin production is seriously affected and patients require daily subcutaneous injections of insulin to normalise blood sugar levels. Diabetes is a treatable condition. However, its treatment is an additional burden. Support from doctor, family and friends is therefore essential. Diabetic patients must check their blood sugar levels at home three or four times a day, using a glucometer. The results of this home monitoring help the doctor to adjust the insulin dose according to the patient's needs. Other laboratory and clinical tests are carried out to evaluate the degree of diabetes complications -- investigation of the kidneys' function and imaging of the fundi - the organs most commonly damaged by diabetes. Thalassaemia patients should be encouraged to stick to regular desferrioxamine treatment, as appropriate use of the drug may considerably reduce their risk of developing diabetes.

Osteoporosis

Thin and fragile bones are a common problem in thalassaemia patients, as a result of several factors: anaemia, overactive bone marrow, low levels of calcium in the diet, increased levels of iron in the bones, poor nutrition, delayed puberty or hypogonadism and other associated endocrine problems, as well as genetic factors, can all

5e Typical sites of osteoporotic fractures

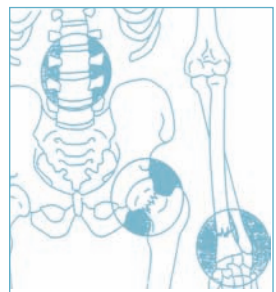

5f Example of DEXA results on a patient with osteoporosis (z score - 5.9)

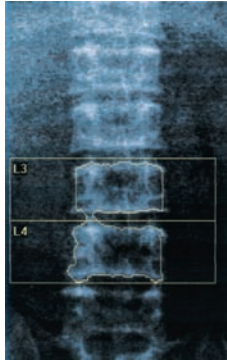

contribute to the development of osteoporosis (5e). Patients with bone disease often have impaired physical activity and severe deformities of the limbs, and suffer very serious fractures.

Bone disease is generally diagnosed by measuring bone density in the area of the spine and the hip, using DEXA and, if indicated, by other laboratory investigations. The World Health Organization (WHO) defines osteopenia as occurring when bone density is reduced to a score of -1 to -2.5 below normal, with osteoporosis described as a bone mass of below -2.5 (5f).

The treatment of bone disease is primarily focused on prevention, through regular blood transfusion, good chelation, treatment of the endocrinopathies and regular exercise. In order to prevent the onset of osteoporosis, patients that have developed osteopenia are advised not to smoke, to follow a diet rich in calcium and to take extra vitamin D, as well as to exercise regularly. In addition, patients diagnosed with hypogonadism should receive sex hormones to prevent the development of osteoporosis. Once osteoporosis has developed, the administration of certain drugs such as biphosphonates (Pamidronate, Aledronate) provide some benefit.

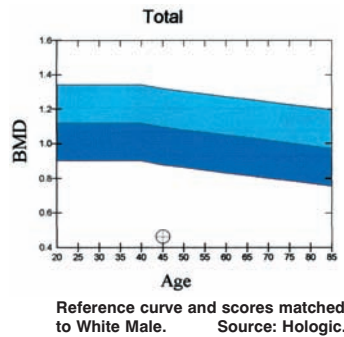

DXA Results Summary:

Region	Area (cm ²)	BMC (g)	BMD (g/cm ²)	T-Score	PR (%)	Z-Score	AM (%)
L3	13.78	5.93	0.430	-6.1	39	-5.9	40
L4	14.83	7.30	0.492	-5.9	43	-5.7	44
Total	28.61	13.23	0.463	-6.0	41	-5.8	42

Total BMD CV 1.0%
WHO Classification: Osteoporosis
Fracture Risk: High

Fertility and reproduction

Women with thalassaemia can safely complete pregnancy. However, the decision to conceive should be carefully considered by a couple in consultation with their doctor.

Women who express the desire to become pregnant should undergo a complete evaluation of their clinical and psychological condition.

Female patients with thalassaemia who have a normal menstrual cycle may conceive spontaneously. However, those suffering from primary or secondary amenorrhoea will need hormonal treatment in order to stimulate the production of ova and the induction of ovulation. Male patients with thalassaemia who suffer azoospermia often respond to a combination of therapeutic hormones, administered over the course of one year.

Once a patient is confirmed to be pregnant, a number of measures should be taken:

1. Use of DFO should stop as soon as the pregnancy is diagnosed, as the effect of the drug on the embryo is not clear. However, in animal studies, it has been associated with severe damage to the embryo. If a pregnant patient is extremely iron overloaded or develops severe heart problems, low doses - 20-30mg/kg/day - have been used in the late stages of pregnancy.
2. Pregnant women are transfused more frequently with low volume in order to keep Hb at satisfactory levels (10-15g/dl).
3. Heart function should be closely monitored. Research has shown that women who begin their pregnancy with lower ferritin levels have better heart function than those with higher ferritin levels.
4. The patient should be monitored for the development of diabetes mellitus or other endocrinopathies.

Many patients with thalassaemia who have received appropriate treatment for fertility problems have managed in recent years to have healthy children. In couples where both partners have thalassaemia major and who wish to have a healthy child, the sperm or ova of a healthy donor are used in the fertilisation procedure, which is completed outside the body in the laboratory, and the fertilised ova are then introduced into the woman's womb. The treatment and follow-up of these patients require an appropriate team approach involving doctors from several specialities, including a haematologist, paediatrician, cardiologist, endocrinologist and gynaecologist.

In conclusion, reproduction in patients with thalassaemia major or intermedia is now a reality. In Cyprus, for example, among 62 women with thalassaemia (50 with major and 12 with intermedia) of average age 25 years, 90 pregnancies were achieved:

- 14 of these through reproductive assistance, induced ovulation, In Vitro Fertilization (IVF) and insemination
- 87 healthy babies were born: 69 full term, 12 pre-term (including 4 twin pregnancies and 1 tripled). There were 7 miscarriages and 2 still-born cases. No severe delivery complications were noted and temporary heart complications were seen in 9 patients.

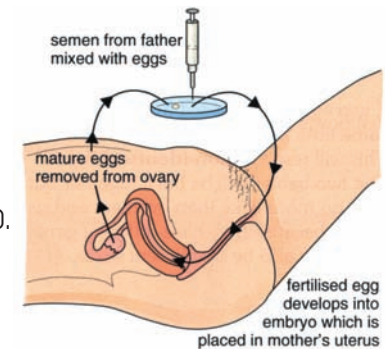
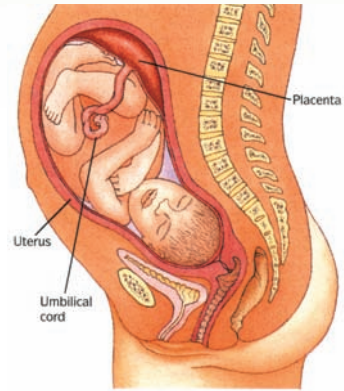

Chapter 6

Infections in thalassaemia

Patients with thalassaemia major have a higher risk of infection because of:

- Anaemia
- Splenectomy
- Iron overload
- Blood transfusions and
- Use of desferrioxamine

Anaemia

Where patients receive insufficient blood transfusions or no transfusions at all, anaemia is the most important cause of serious infections such as pneumonia. Although this is rarely a problem in the West where adequate blood is more easily available, insufficient transfusion is a regular problem in some countries of the developing world and such infections may therefore still occur.

Splenectomy

Patients who did not begin blood transfusion therapy early enough or who have had their spleen removed face a significant risk of developing serious infections such as streptococcus pneumonia, haemophilus influenza, and Neisseria meningitides caused by encapsulated bacteria. Other bacteria, viruses and parasites may also cause serious infections in patients who had their spleen removed. This is because the spleen, as mentioned earlier, is involved protecting the body against infections.

Iron load

Patients who are well transfused but inappropriately chelated - either because of difficulties procuring Desferrioxamine or a low level of compliance - may also have an increased risk of developing severe infections. This is because infectious agents thrive on iron: the higher the level of iron in the body the more quickly such agents may grow and multiply, causing very serious infections. The best-documented infection is caused by a bacterium

called *Yersinia enterocolitica* - a peculiar infectious agent that, unlike other bacteria, does not have a mechanism of its own for collecting and using iron from its own environment. In healthy individuals, these bacteria are harmless and of little or no clinical importance. However, in thalassaemia major, where there is excess iron either free or bound to the desferrioxamine molecule, *Yersinia* grows and multiplies rapidly, causing serious, life-threatening infections.

Although more work has been carried out on the role of iron in bacterial infections, there has also been considerable research into the role of iron in viral infections (such as hepatitis and AIDS), examining how iron may affect the progression of these infections and their response to treatment with recommended drugs. The results of these investigations indicate that in thalassaemia major, iron overload may be related to a worse prognosis for chronic viral hepatitis B and C and a poorer response to the treatment of chronic viral hepatitis. The effectiveness of iron chelation therapy thus seems to play an important role in the prognosis of chronic viral hepatitis in these patients.

It has also been demonstrated that HIV infection in patients with thalassaemia major becomes more severe when their chelation regime includes less than 40mg/kg body weight of desferrioxamine, or when serum ferritin levels are above 1935µg/L.

In summary, iron may play an important role in increasing the severity of infections in thalassaemia major, because iron may:

- (i) serve as a nutrient for the growth of pathogens
- (ii) serve as a nutrient for proteins called enzymes that support the multiplication of infectious organisms
- (iii) remove important chemicals called antioxidants that protect the body's cells against inflammation
- (iv) damage certain types of cells that play an important role in the body's defence against infection.

Transfusion-associated infections

Blood has long been recognised as a major source of infectious agents that can be transmitted to patients through transfusion. So although blood can save lives,



it can also cause a number of unwanted reactions, including serious, life-threatening infections.

Many types of microorganisms can survive for some length of time in blood, infecting patients when the blood is transfused. Among these are hepatitis B and C and HIV1 and 2, all of which are clinically significant pathogens and can cause serious chronic infections. In Europe and North America, improved blood transfusion services, vaccination programmes, donor blood screening and high quality public health services in general have made transmission of these pathogens a very rare event today; infections with HBV, HCV and HIV have been reduced to nearly zero in these countries. In many developing countries, however, infections from blood transfusions still occur, due to the poor quality of blood transfusion services, fragmented health care services, limited resources and the challenge of meeting other health priorities. As a result, patients with thalassaemia major in many developing countries are still being infected through blood transfusions. Infections with hepatitis B and/or C are of particular clinical importance in patients with thalassaemia major, as they may greatly aggravate the iron-related liver disease that is common in such patients as a result of the disease itself or of inappropriate iron chelation treatment. Liver disease is a common cause of morbidity and death amongst mainly older patients with thalassaemia in industrialised countries, and of patients of almost all ages in developing countries.

Hepatitis B virus (HBV) infection

Chronic hepatitis B infection (CHB) remains a serious public health problem in many developing countries, despite the fact that both effective and safe vaccines, and high quality commercially-available tests for screening donor blood have been available for sometime.

Transmission

The hepatitis B virus is transmitted in a number of ways in addition to blood transfusions, including sexual contact or from a pregnant woman to her child - during pregnancy, at delivery or while breast-feeding. However, patients with thalassaemia major are most frequently infected with hepatitis B through blood transfusions.

The transmission of HBV maybe prevented by implementing appropriate policies for:

- (i) selection and testing of blood donors
- (ii) HBV vaccination and sterilisation programmes
- (iii) prevention of "vertical" transmission, i.e. transmission from an infected mother to her newborn.

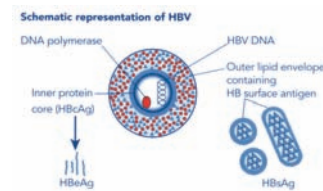
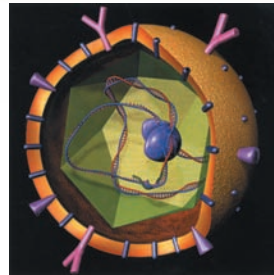

Natural history of HBV

About 5-10% of patients infected with HBV will be infected for life - i.e. they will become chronic carriers - with an increased risk of developing liver disease. In the case of infants, 90% of those born to infected mothers will be lifelong carriers of the hepatitis virus if no preventative measures are taken. About 25-30% of those chronically infected with hepatitis B develop progressive liver disease. The percentage of patients with thalassaemia major infected with hepatitis B, and therefore at increased risk of developing serious liver disease, varies from country to country, depending on the implementation of preventative measures such as HBV vaccination, donor selection and screening and, very importantly, on the local prevalence of HBV.

According to published data, between 2-35% of patients with thalassaemia major worldwide are carriers of hepatitis B and between 20% - 90% have laboratory evidence that they have been infected with the virus at some time in their lives (past infection). In the developed world, the majority of patients carrying hepatitis B are older, infected before the establishment and improvement of

Natural history of hepatitis B virus infection

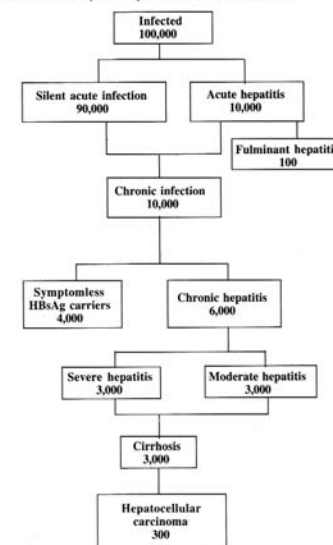

vaccination and blood testing policies. In the developing world, however, patients of all age groups continue to be infected with the virus.

As soon as diagnosis of thalassaemia major is confirmed and before beginning blood transfusions, the patient should be tested to establish his/her HBV status -- i.e. whether he/she is a chronic carrier or has been infected with hepatitis B in the past. If patients are neither, they should be vaccinated against the virus, irrespective of their age. All patients with thalassaemia major are tested for HBV annually. These tests include surface antigen (HbsAg), antibodies to HBV (anti-HBs), e-antigen (eAg), antibodies to eAg (anti-HBe) and antibodies to the core (anti-HBc). It may be necessary to test chronic HBV carriers (see 6a) more frequently in order to evaluate the most appropriate time for initiating treatment. Iron overload in patients with thalassaemia major infected with chronic hepatitis B is an additional factor that may contribute significantly to liver damage, and effective iron chelation treatment is very important.

Treatment of chronic HBV infection

The treatment of chronic hepatitis B aims to reduce and maintain the suppression of HBV and to prevent the consequences of the infection. The treatment of HBV infection has improved significantly over recent years. Drugs or anti-virals commonly used include the classical treatment with alpha-recombinant Interferon, the use of which is long-established. Alpha interferon, a chemical capable of modulating the immune system, has been shown to induce clearance in 25-40% of patients with chronic active hepatitis. A more recently developed antiviral is Lamivudine. Lamivudin (epivir™ - HBV, 3TC) used alone or in combination with interferon has dramatically improved the treatment of chronic HBV, although the development of resistance in a proportion of patients - 14-32%, in the first year and 67% after 4 years - is considered a major disadvantage. A new drug commercially available for use in the treatment of CHB is the oral drug Adefovir dipivoxil which has proved as effective as Lamivudine in suppressing the virus, and has overcome concerns of resistance. Other promising drugs are (i) the new form of Interferon developed for better efficiency called pegylated Interferon, and (ii) entecavir, both of which are still under investigation for the treatment of HBV infection.

6a Serological profile of chronic HBV infection

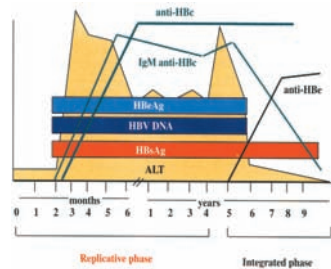

The decision of when to treat the disease and the choice of drug or combination of drugs to be used should be made by the treating physician in close collaboration with a hepatologist - a specialist in the treatment of liver disease. Overall, however, where resources and availability allow, the use of these drugs according to internationally approved guidelines has tremendously improved the management of chronic hepatitis infection and significantly reduced the risk of developing serious liver disease, including cirrhosis (compensated and decompensated) and hepatocellular carcinoma (HCC).

Hepatitis C (HCV)

HCV leads to chronic, lifelong infections in more than 80% of those infected. Unlike hepatitis B, however, HCV is not easily transmitted by routes other than blood transfusion. There is not yet a safe and effective vaccine against HCV, although there are laboratory tests that can accurately detect the virus in blood. Therefore the only effective way to prevent the transmission of HCV-and reduce rates of infection-is to ensure that donor blood is carefully tested. However, HCV, contrary to other viruses, has a long incubation period--that is, the virus can be infectious for a long time once it is in blood--in a form that cannot be detected for some time by the most common (antibody) tests used at most blood banks. During that period, the blood may be transfused and a patient infected. Testing for HCV has received considerable attention in an effort to reduce this infectious period (also called the "window phase" or the "immunosilent period") as much as possible and so decrease to a minimum HCV transmission through blood.

Natural history of HCV (see 6b)

About 20% of chronic carriers of HCV will develop mild liver disease (fibrosis); 20% of these may develop more serious liver disease such as cirrhosis and hepatocellular carcinoma. Cirrhosis develops within 10 years in about 10-20% of patients with chronic Hepatitis C (CHC). Hepatitis C infection is the most common cause for liver transplantation.

There are six main types (genotypes) of hepatitis C (see 6c), each with different geographic distributions and clinical significance. Between 10-80% of patients with thalassaemia major worldwide are infected with the virus and HCV infection is one of the major causes

HCV virus

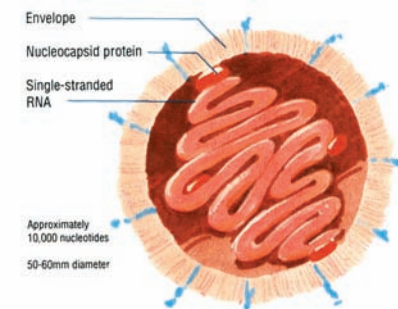

Utility of diagnostic tests (adapted from Gretsch, 1997)

Method	Screen	Confirmation	Assessing response to therapy	Predicting treatment response and length of therapy
ALT	X		X	
Enzyme immunoassay	X			
Recombinant immunoblot assay		X		
HCV RNA qualitative assay		X	X	
HCV RNA quantitative assay			X	X
Genotype				X

Natural history of HCV infection

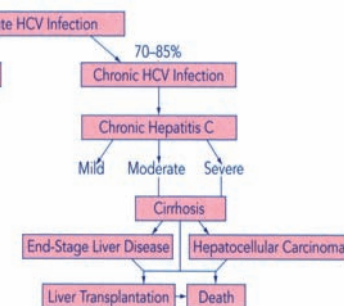

6b

6c Global geographic distribution of HCV genotypes (Zein, 2000)

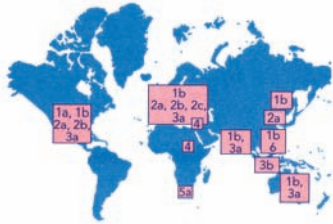

of serious chronic liver disease in these patients. As in hepatitis B, iron overload in non- or inappropriately chelated patients is an additional factor that may contribute significantly to liver damage. It is therefore important that all patients with thalassaemia major infected with HCV receive appropriate iron chelation treatment and undergo special laboratory tests for hepatitis C once a year (see 6d). The coexistence of HCV and HBV, which is frequent in patients with thalassaemia major since both viruses are efficiently transmitted through blood, may contribute significantly to a much more rapid progression to serious liver disease.

6d Serological course of HCV infection evolving to chronicity; other antibody patterns are possible

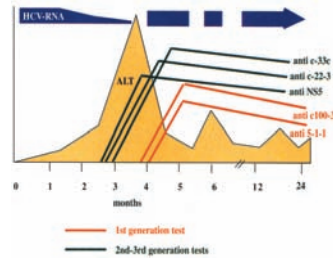

Treatment of chronic hepatitis C (CHC)

Initially, the treatment of HCV infection included the use of classical recombinant α -Interferon monotherapy, although with very low rates of sustained response (10-25%). The treatment of CHC has, however, significantly improved in recent years. Currently recommended treatment includes the use of classical recombinant α -interferon in combination with Ribavirin - an oral drug with antiviral properties. However, Ribavirin therapy is associated with haemolysis i.e. the breakdown of red blood cells. This is because it causes a considerable reduction in an important constituent of red cells, ATP (Adenosine Tri Phosphate), responsible for their survival. Patients with thalassaemia major using ribavirin may experience more marked haemolysis and may need more frequent blood transfusions (about 30% increase), which in turn requires intensified chelation therapy to remove the extra iron. More recently, the new, significantly improved form of interferon - pegylated interferon - has been used either alone or in combination with ribavirin, considerably improving response rates and providing other treatment options for patients with CHC. The type and duration of treatment depends on the type (genotype) of hepatitis C virus identified, with type 1 considered the most difficult to treat.

Treatment should be decided upon in consultation with a hepatologist. New treatment regimes have increased success rates from the low of 10-25% seen using alpha recombinant interferon alone, to over 60% for types other than type 1, and up to 48% for type 1. Antiviral treatment for both HBV and HCV infections is

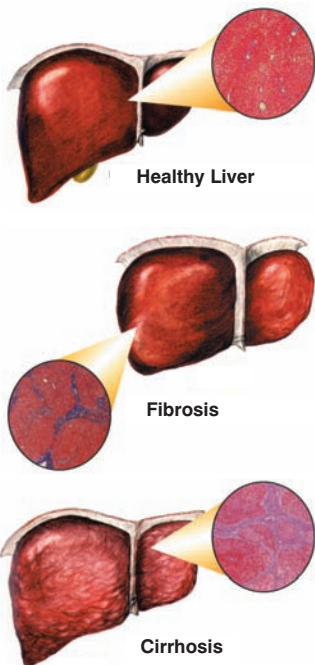

very expensive and availability in many countries of the developing world is unfortunately limited. Some general precautions concerning the transmission of HCV and HBV are to avoid sharing toothbrushes, razors and other sharp objects kept for personal use. HBV is much more infectious (i.e. it passes between individuals much more easily) than hepatitis C, however, proper vaccination against the virus almost completely eliminates the risk of transmission.

Human immunodeficiency virus (HIV)

HIV is the infectious microorganism (see 6e) that causes AIDS - Acquired Immune Deficiency Syndrome.

HIV belongs to a family of viruses known as "retroviruses", which have special biological characteristics that control the way they multiply and their behaviour inside the cells of the body it attacks. White blood cells known as lymphocytes (CD4), are the most important of the body's cells able to bind with this virus (see 6f). The virus enters these cells using a mechanism that allows it to become part of the cell's DNA, permanently establishing itself in the body of the infected individual, multiplying in the lymphocytes and damaging the cells (see 6f). Lymphocytes play an important role in the body's immune system. But once invaded by a retrovirus, they lose their ability to protect the body against infection. Without treatment, the disease becomes serious in about 7-11 years, although clinical symptoms and severity may appear much earlier and there is no time frame as to when serious disease will begin. In the early stages, an infected individual demonstrates no laboratory or clinical indications (described as asymptomatic). Once symptoms develop and/or laboratory results indicate serious damage to the infected cells and rapid rates of virus growth, the disease has moved to a more serious stage, and the individual is described as having AIDS.

The main cause of death in untreated AIDS patients is infection, which becomes life-threatening in the absence of an effective immune system. Almost any pathogen will cause severe to fatal infections in untreated AIDS patients, including pneumocystic carinii - the most frequent cause of death in untreated patients.

HIV is passed on (transmitted) from one individual to another through blood, unprotected sex or from an infected mother to her child (referred to as the 'vertical route' of transmission).

6e

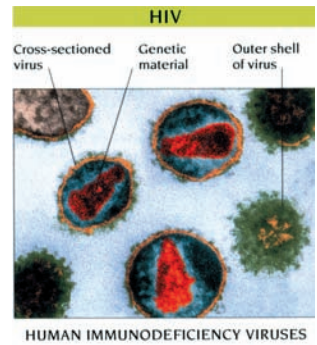

HUMAN IMMUNODEFICIENCY VIRUSES

6f

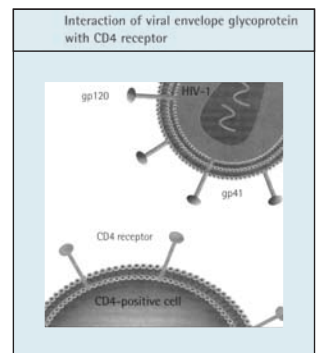
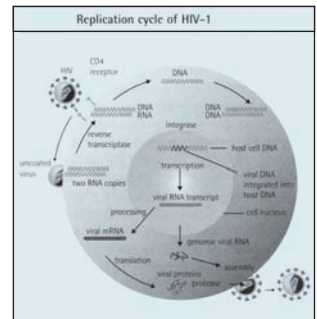

As in the case of HBV and HCV, preventing the transmission of HIV through blood involves careful laboratory testing of donors' blood and quality blood transfusion services. Transmission of HIV through other routes can be significantly reduced by avoiding multiple partners and unprotected sex. As in the case of HCV, there is not yet a safe and effective vaccine against HIV.

Numerous drugs known as anti-retrovirals (against the retrovirus), which interfere at various stages (see 6g) of the entry and exit of the virus from the cell or during its multiplication (replication) inside the cells it infects, have been in use since 1996. Used in combinations of two, three or more, according to international guidelines regularly updated by specialists working in the field, these drugs have literally changed the natural history of the disease. Both the survival and quality of life of patients infected with HIV have improved tremendously since they became available. Anti-retroviral drugs have also been very successfully used to prevent - in over 80% of cases - the vertical transmission of the virus, i.e. from an infected mother to her foetus and/or infant. However, as in HCV and HBV treatment, drugs used in the treatment of HIV are extremely expensive. The majority of infected patients live in poor countries where,

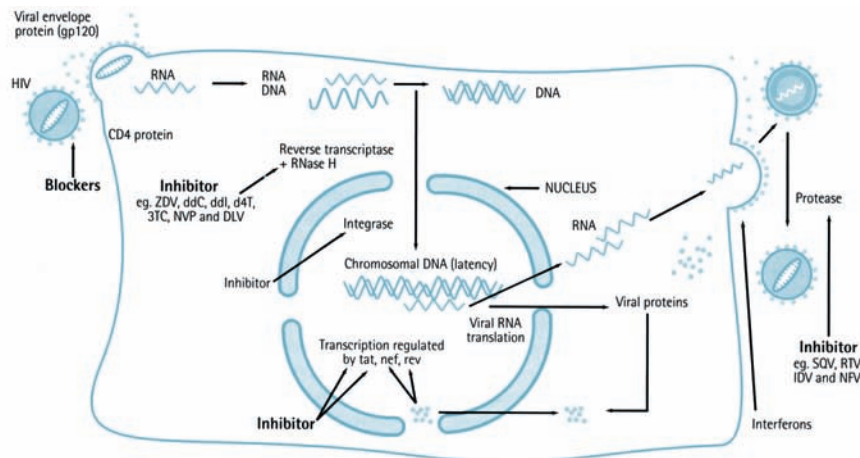

6g Life cycle of HIV showing opportunities for drug intervention

despite concerted efforts, such drugs are extremely limited and often prohibitively expensive. Although published data so far indicates low rates of HIV infection amongst patients with thalassaemia major, figures are likely to be significantly higher once data from more countries becomes available.

A wide range of other micro-organisms can be transmitted through blood. Although these may not cause chronic infection, in patients with thalassaemia major or other haemolytic anaemias, particularly those whose immune system has been sharply suppressed, for example after undergoing transplant surgery, these may become clinically significant.

Other viruses

Human Parvovirus B-19

The Human Parvovirus B-19 (HPV B-19) is another virus that can be transmitted through blood (although this is not the main route by which the virus is transmitted). The most important effect of this virus on patients with thalassaemia or other haemolytic anaemias such as sickle cell is that it can cause a temporary halt in the production of red blood cells - referred to as transient aplastic crises. The acute phase of infection with HPV B-19 is characterised by a sudden drop in haemoglobin and the disappearance of peripheral red cell precursors - reticulocytes. Where infection is promptly diagnosed, the patient can usually be treated with a transfusion of whole blood which usually contains sufficient antibodies to fight the virus. However, immune-suppressed patients - i.e. those that have undergone bone marrow transplantation or patients with HIV - infected with the virus may develop more serious, sometimes chronic, clinical complications.



Human Cytomegalovirus

A virus that poses even greater dangers to immune-suppressed patients is Human Cytomegalovirus (CMV). This virus causes severe infections in transplanted patients and is often fatal if not promptly diagnosed and treated. An important characteristic of this virus is its ability to lodge itself permanently in the cells it infects (mainly white blood cells), reactivating unpredictably and causing severe "secondary" or "recurrency" infections. It is therefore important that patients with thalassaemia major - particularly those who may be candidates for bone marrow transplant or those who have undergone BMT, receive filtered blood from which as many white blood cells and their associated pathogens, including CMV, have been removed.

Malaria and Chagas Disease

Post transfusion malaria and Chagas disease have been known for more than 50 years. Plasmodium species and Trypanosoma cruzi, causative agents of malaria and Chagas disease respectively, may remain alive for at least two weeks in refrigerated blood components and even in frozen plasma.

As a result of serious concerns that tourism to endemic countries and increasing migration from endemic countries to non-endemic might increase the transmission of malaria and Chagas disease, the World Health Organization, the Council of Europe, the US health authorities and National Blood Transfusion Services have jointly drawn up standards aimed at the prevention of post-transfusion malaria and Chagas disease, including deferral and/or testing of blood donors.

New pathogens

So-called new pathogens discovered between 1995-98 include other hepatitis viruses in addition to hepatitis B and C - hepatitis G (HGV or GBV-C), SEN-V and TTVirus. Although the transmission of such viruses through transfusions has been well documented, their role in the development of liver disease is not yet clear.

New worries from old pathogens

Creutzfeld-Jakob disease (CJD) and its new form or variant - (vCJD), the human form of bovine spongiform encephalitis (BSE), a disease found in cattle - is a deadly disease that affects the nervous system. The disease is caused by the prion protein rather than a true virus, while its structure makes it hard to classify with other infectious agents (microbes, bacteria and parasites). What is known is that under certain, unclear, conditions the human organism transforms the prion protein into a harmful agent that is associated with a slowly progressing neurological fatal disease. Although the disease has been known for years, the importance of CJD and its new variant came to prominence in the mid-1990s when post-mortem examinations identified a spate of cases, mainly in the UK but later also in other countries in smaller numbers. By December 2001, there were 113 cases in the UK, 4 in France and 1 each in the Republic of Ireland and Hong Kong.

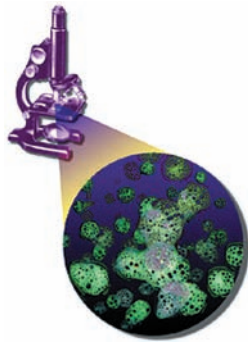

All cases of new variant CJD documented so far are thought to be the result of patients eating products made from infected cattle. Transmission has also been documented in patients who have received certain hormones derived from humans (growth hormones), and those who have received duramater and corneal transplants. Transmission after neurosurgery and electroencephalographic procedures with insufficiently sterilized instruments have also been reported. There have been no reported instances of infection via blood transfusion. However, because of the seriousness of the disease and the presence of the prion protein in lymphatic tissue, a number of western countries - particularly the UK - have invested considerable resources in policies aimed at preventing its transmission through blood. One of the policies implemented is universal filtration i.e. filtration of all blood collected, through which the greatest majority of white blood cells (lymphocytes) is removed.

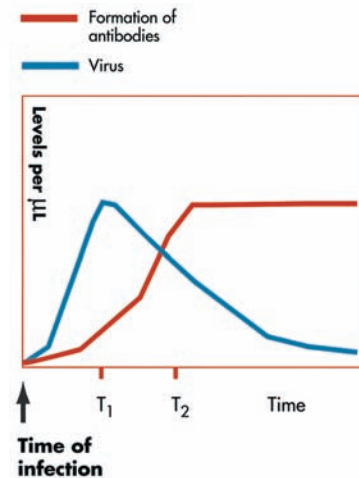

Blood safety

International efforts have focused on preventing the transmission of infectious micro-organisms through transfusions. Factors contributing to blood safety include:

- (i) Establishing policies aimed at securing regular, voluntary, non-paid blood donation, from appropriate donors
- (ii) High quality blood transfusion services, including mandatory laboratory testing of donors' blood for HIV, HBV, HCV, syphilis and any other locally prevalent pathogens.
- (iii) Establishing other public health measures such as vaccination and sterilisation processes

Over recent years industrialized countries have also applied specialised DNA laboratory technology known as nucleic acid testing (NAT) to blood screening, leading to a further impressive reduction in the risk of transmission of clinically important viruses, however at very high cost.

Bacterial contamination

In addition to viruses, other microorganisms such as bacteria and parasites can live and multiply in blood, infecting patients through transfusions. Indeed, rates of blood contamination by bacteria are 50-250 times higher than that caused by viruses. Often such contamination occurs in simple ways - and can be easily avoided. For example, a common source of contamination is poor hygiene - when the skin of the donor giving blood is not properly

disinfected before the needle is inserted. As the needle pricks the skin, it gathers bacteria from the surface of the skin, carrying them into the collected blood.

New approaches to blood safety

In an effort to further reduce the possibility of contamination by all types of pathogens, new technologies have been developed that aim to destroy pathogens' DNA when they are added to a unit of donated blood. This method is called pathogen inactivation. It is the first proactive blood safety measure, as it inactivates pathogens' even if not known to be contained in the blood unit or not yet known at all. Research and clinical studies are at an advanced stage and one technology is now being approved and commercialized for platelets in Europe; the ultimate objective being to apply this technology to other blood components including red blood cells.

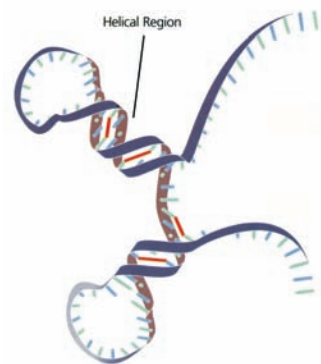

Safety and availability of blood in the developing world

In many developing countries, the risks associated with blood transfusion are significantly greater than in the industrialised world. In most developing countries, adequacy (i.e. the availability) of blood is an important problem, while the quality of blood transfusion services, including donor selection policies and vaccination programmes are not up to the standard recommended in Europe and the United States.

Financial constraints, competing priorities and political instability can all slow the process of implementing high standards of blood safety. According to data compiled by the WHO blood safety unit, 80% of the global population lives in the developing world but they receive less than 40% of the world's total annual blood supply of 75 million units. Only an estimated 16% of blood supply collected in developing countries is donated by voluntary, non-remunerated, low-risk blood donors, while 43% of blood is not fully tested. As a result, HIV, HBV and HCV infections through blood transfusions are expected to occur in many developing countries - and in some at high rates. A more concerted effort is needed by all international and national health organizations and authorities, in order to improve blood safety and availability in these countries.

Summary of what eventually happens in untreated thalassaemia major

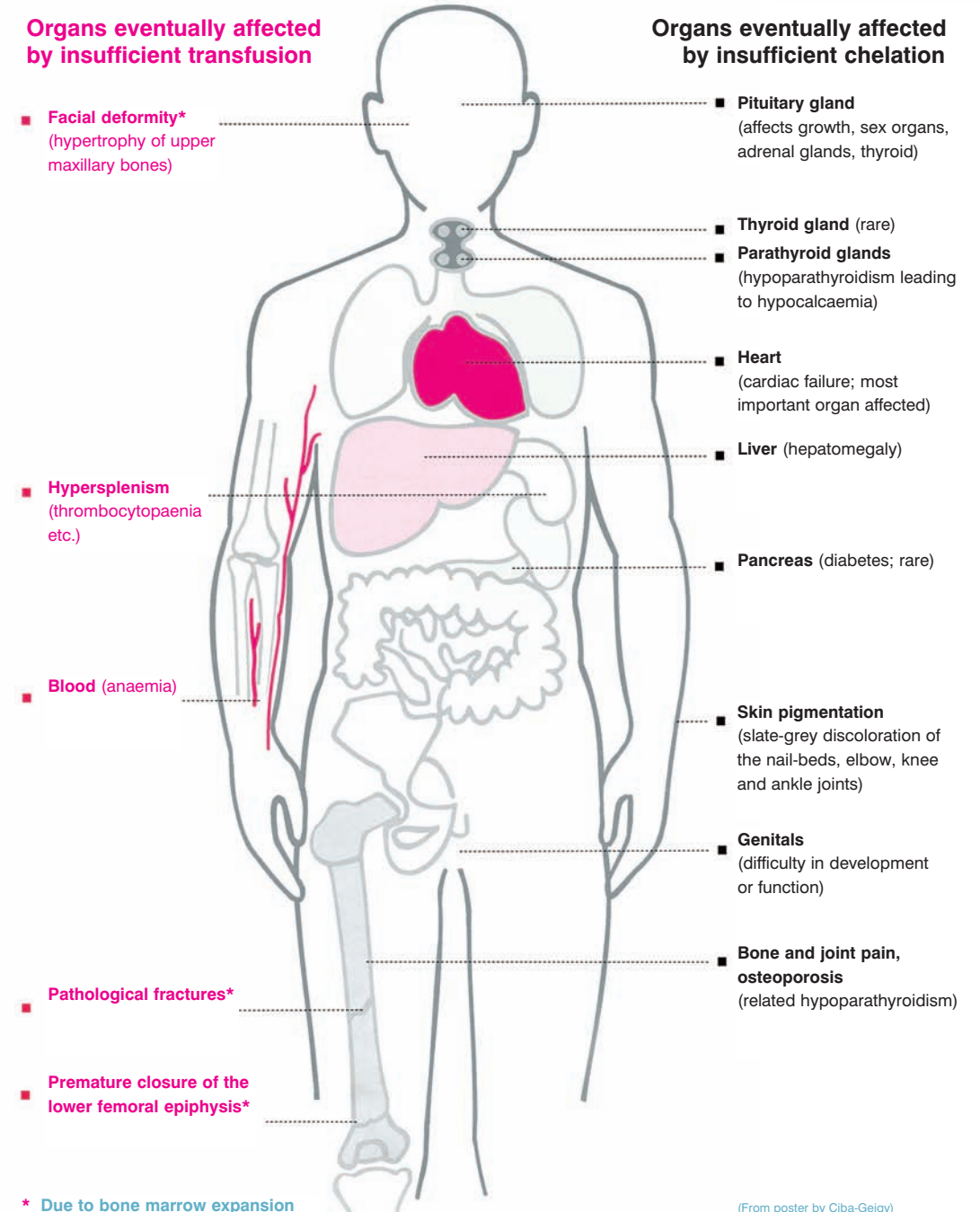

(From poster by Ciba-Geigy)

Chapter 7

Thalassaemia intermedia and other thalassaemias

Thalassaemia intermedia is a medical condition in which individuals have inherited an affected β -gene from both the mother and father (i.e. they are homozygous for β -thalassaemia) but they demonstrate milder clinical symptoms than patients with thalassaemia major. Individuals with thalassaemia intermedia manage to maintain haemoglobin levels between 6-9g/dl and may not require regular blood transfusions.

However, considerable research into the condition has demonstrated that thalassaemia intermedia in fact covers a wide range of clinical symptoms, some of which can be severe. In the most serious cases, patients may present clinical and laboratory evidence of the disease between the ages of 2-6. Although growth and physical development is slower than normal, these patients may maintain a good quality of life without the regular blood transfusions required by β -thalassaemia major patients. In less serious cases, patients may not demonstrate any symptoms until they are adults, suffering only mild anaemia (8-10g/dl) and only rarely requiring blood transfusions - if at all.

The spleen may become enlarged (splenomegaly) - as in thalassaemia major - because of the rapid breakdown and accumulation of red blood cells in the organ, and this may sometimes be the cause of more severe anaemia in patients with thalassaemia intermedia. In such cases patients may need to be transfused more regularly. Removing the spleen may also correct the complication, however this is a very serious decision that should be taken with expert medical advice, taking into account the possible effect on other aspects of the patient's health besides relieving the anaemia, such as the possibility of infection.

As described in Chapter 2, the main cause of symptoms in thalassaemia major is the excess amount of free α -chains that accumulate inside the red blood cells, creating an imbalance between the α -chains and their usual

partners, the β -chains. Alone, the α -chains interfere with almost every stage of red blood cells' cycle of maturation, causing the severe anaemia and other conditions discussed earlier.

Given the above, it is reasonable to expect that the symptoms manifested by thalassaemia patients will be less severe where conditions exist in which the number of excess α -chains is reduced. Investigations at the molecular level have shown that a number of such conditions exist, including:

- (i) The presence of the β^+ gene, which can produce some β -chains - although less than normal - that in turn couple with α -chains, thus reducing the number of free α -chains. Mutations to the β^+ gene that are associated with a very mild clinical outcome are sometimes designated β^{++}
- (ii) A defect on the gene responsible for the synthesis of α -chains, reducing the number of α -chains produced and so improving the balance between α - and β -chains
- (iii) A greater level of activity by the γ -genes responsible for producing γ -chains, which can bind α -chains to produce foetal haemoglobin ($\alpha_2\gamma_2$), thus reducing free, harmful α -chains. Conditions that may favour γ -chain production include: $\delta\beta$ -thalassaemia, hereditary persistence of foetal haemoglobin (HPFH) and a change at a particular site in the γ gene called XmnI.

As the above points indicate, medical staff can greatly enhance their knowledge of a patient's condition by establishing the exact type of damage to that patient's DNA. It is then easier to set out the most appropriate treatment programme for an individual patient. Where available, such molecular methods of investigation are proving invaluable aids to the treatment of thalassaemia.

Diagnosis

In diagnosing thalassaemia intermedia, it is important to establish certain clinical and laboratory information, in order to differentiate thalassaemia intermedia from thalassaemia major. However, this is not always easy or even possible, despite impressive improvements in molecular laboratory techniques. Nonetheless, some useful and simple criteria for differentiation are the following (see 7a):

MANIFESTATIONS OF THALASSEMIA

	MAJOR	INTERMEDIA	MINOR
Clinical	Onset in Infancy	Later Onset	Asymptomatic
Splenomegaly	++++	+++--++++	0--+
Jaundice	+++	+--+++	0--+
Bone changes	++++	++--++++	0
Facial changes	++--++++	0--++++	0
Hematologic			
Anemia	++++	++--+++	0--+
RBC	↓	↓	N - ↑
Microcytosis	+	+	+
NRBC	++--++++	+--+++	0
Biochemical			
HbF	10-95+%	10-95+%	N or <10%
HbA ₂	N or ↑	N or ↑	N or ↑ (>3.5%)

(Proceedings from a conference, MA Nov. 14, 1996)

Management of thalassaemia intermedia

In thalassaemia intermedia, the most important question is when to begin blood transfusion therapy. The following medical conditions may result from chronic anaemia, and certainly constitute reasons for initiating blood transfusion therapy:

- delayed growth
- pathological bone fractures
- cardiac complications
- facial deformities
- decreased normal physical activity
- hypersplenism

As in the case of thalassaemia major, it is important that patients are closely monitored through regular medical and laboratory check-ups aimed at promptly identifying the appearance of any complications. In addition, because patients with thalassaemia intermedia begin blood transfusions later in life than patients with thalassaemia major, it is important to pay particular attention to the possible development of reactions (alloimmunisation) described earlier, as such reactions usually occur when

In conclusion, the term thalassaemia intermedia is used to describe a wide range of clinical and haematological findings in patients with less severe forms of the disease than homozygous β -thalassaemia, but more severe than that of heterozygous carriers.

transfusions begin at a later age. It is therefore essential that the patient and donor's blood are carefully typed and matched before every transfusion. It is also important to note that pregnant women with thalassaemia intermedia may require blood transfusions.

Iron chelation

As in thalassaemia major, iron overload in patients with thalassaemia intermedia may be due to:

- ineffective production of red cells
- the breakdown of red cells
- increased quantities of iron absorbed by the gut

There has been comparatively little research into iron accumulation in patients with thalassaemia intermedia. However, one study demonstrated that 2-5g of iron accumulate in the body of patients with thalassaemia intermedia each year -- that is, 0.1mg/kg/day. This is a 20-70% higher rate of absorbing iron from the diet than normal. As they get older - in most cases after a decade - patients with thalassaemia intermedia therefore have almost the same risk of iron-associated complications as patients with thalassaemia major receiving regular blood transfusions.

A difficulty in deciding when to start iron chelation in patients with thalassaemia intermedia is determining the patient's actual body iron overload, as serum ferritin levels may not provide an accurate measure - again, as is the case with thalassaemia major. For this reason it is advisable to assess iron concentration by means of a liver biopsy, or through newer, more sensitive and non-invasive methods such as SQUID or MRI.

Once a decision has been taken to begin iron chelation therapy, it is recommended that Desferrioxamine be used, as in the case of thalassaemia major, although patients with thalassaemia intermedia may require a subcutaneous infusion no more than 2 or 3 days a week. The same follow-up treatment recommended for patients with thalassaemia major undergoing iron chelation should also be made available to patients with thalassaemia intermedia.

As patients with thalassaemia intermedia absorb significantly more iron from the gut than normal, they should avoid foods rich in iron (e.g. spinach, liver and some kinds

of beans) as well as iron supplements. Drinking black tea with meals may help to reduce the amount of iron absorbed by the gut.

Medical problems in thalassaemia intermedia

- (1) Bone changes. Hyperactive bone marrow - a result of the body's effort to produce more red blood cells to counteract anaemia - causes the bones to become distorted, fragile and thinner, interrupting their growth and leaving patients vulnerable to fractures. However, severe bone problems can be overcome through regular blood transfusion therapy.

Osteoporosis. Patients are encouraged to exercise and to increase the calcium in their diet in order to avoid serious bone disease (osteoporosis). Calcium and vitamin D capsules may provide additional benefit. Smoking should also be avoided. Some doctors have demonstrated beneficial results with the use of biophosphonates, administered orally or intravenously, however their role in combating osteoporosis has yet to be confirmed.

- (2) Hyperactivity or expansion of the bone marrow and folic acid. Because the bone marrow of patients with thalassaemia intermedia works extra hard in an effort to combat the body's anaemia by making more red blood cells, patients need extra amounts of certain vitamins, particularly folic acid. Insufficient folic acid can aggravate the anaemia in thalassaemia intermedia patients. Folic acid is found naturally in food such as meat and green vegetables. However, an additional amount - usually a tablet a day - should cover patients' extra needs.
- (3) Gall stones. Thalassaemia intermedia patients develop gallstones (cholelithiasis) more frequently than normal. Gallstones are made from the by-products (bile pigments) released when red blood cells are broken down, accumulating in an organ next to the liver called the gall bladder where they may cause an obstruction, prompting pain in the abdomen. The presence of gallstones can be confirmed by ultrasound examination. If pain in the abdomen persists, the gall bladder may be removed.
- (4) Leg ulcers. Patients with thalassaemia intermedia fre-

quently develop ulcers around the ankle, particularly older patients, as a result of poor circulation and oxygenation in some parts of the body. These ulcers tend to be persistent and very difficult to treat. However, regular blood transfusions to raise haemoglobin levels and so improve the supply of oxygen to the tissues, as well as simple measures such as keeping the legs and feet raised above the level of the heart for 1-2 hours a day, sleeping with the end of the bed slightly raised and protecting the ankles by wearing socks, may offer some comfort. Drugs such as zinc sulphate tablets are also sometimes helpful, as well as hydroxyurea - either alone or in combination with other agents that can increase foetal haemoglobin, such as erythropoietin and butyrates.

- (4) Kidney complications. Other medical problems reported among patients with thalassaemia intermedia include kidney damage, which may be the result of excess uric acid in the blood. Uric acid is the most important waste product formed as a result of overactive bone marrow. The drug Allopurinol may help reduce the amount of uric acid produced.
- (5) Thrombophilia. Another complication is an increased risk of thrombosis, where thrombocytes or platelets (see section in blood) accumulate in the blood vessels to form clots (aggregates) that prevent normal blood flow and so reduce the oxygenation of cells and tissues. Regularly counting the number of platelets allows the doctor to establish whether to prescribe anti-aggregates, if these are raised, or anti-coagulants if surgery is planned or if thrombosis occurs.
- (6) Extra medullary erythropoiesis - the production of red blood cells outside the bone marrow. Unlike thalassaemia major patients, who receive regular blood transfusions from an early age which suppress excessive activity of the bone marrow, patients with thalassaemia intermedia do not receive such regular blood transfusions and so continue to produce high levels of red blood cells, including in areas outside the bone marrow - mainly in the chest area and near the spine. X-rays can reveal blood-forming tissue developing in masses in these areas.

The production of red blood cells near the spine can cause neurological complications when extra pressure

builds up around the spinal cord. Such activity can usually be identified through x-rays or with more sensitive methods such as MRI. Again, such conditions can usually be managed through blood transfusion therapy, which will suppress the extra formation of blood and, as a consequence reduce the masses formed. Where serious neurological conditions occur, more active therapeutic measures may be needed, such as radiotherapy.

- (7) Heart and liver complications. Chronic anaemia may also cause heart problems, while both the heart and liver may be damaged by iron overload. Both conditions can be managed as in the case of thalassaemia major.

Thalassaemias associated with "abnormal haemoglobin" or structural haemoglobin variants

"Abnormal haemoglobins" differ from normal haemoglobin in structure and sometimes also in behaviour. The important abnormal haemoglobins are:

- Haemoglobin S (HbS)
- Haemoglobin C (HbC)
- Haemoglobin E (HbE)
- Haemoglobin D (HbD)
- Haemoglobin Lepore

These haemoglobins are inherited in the same way as β -thalassaemia. For example, individuals who inherit one gene for normal haemoglobin and one gene for the abnormal haemoglobin S, C, E or D are called carriers of HbS, HbC, HbE or HbD, respectively. Carriers can be detected by laboratory tests, just as β -thalassaemia carriers.

Homozygote abnormal haemoglobin

Individuals may inherit one abnormal haemoglobin (S, C, E or D) from one parent and a different abnormal haemoglobin (S, C, E or D) from the other parent. However, only those that inherit haemoglobin S from both parents have a clinically significant condition - referred to as homozygous for haemoglobin S, or sickle cell anaemia. No disease is associated in the majority of cases with homozygous haemoglobin C, D or E, and these are therefore not clinically significant.

Compound "abnormal haemoglobins" with β -thalassaemia

The most common combinations of β -thalassaemia with "abnormal haemoglobins" are:

- HbS/ β -thalassaemia and
- HbE/ β -thalassaemia

HbS/ β -thalassaemia - produces a clinical condition more similar to sickle cell diseases than to thalassaemia major or intermediate.

HbE/ β -thalassaemia - this is the most common "abnormal" or haemoglobin variant with thalassaemic properties and is most prevalent in South East Asia. The combination also exhibits a great range of clinical symptoms (diversity of phenotypes or spectrum of severity). Clinically, β -thalassaemia/HbE may be classified in three levels, depending on the severity of the symptoms:

- mild β -thalassaemia/HbE - found in about 15% of all those affected in South East Asia. This group of patients does not develop any clinical problems and maintains haemoglobin levels between 9-12g/dl.
- moderately severe β -thalassaemia/HbE - the majority of patients in this group develop clinical symptoms similar to those of β -thalassaemia intermedia and have steady levels of haemoglobin between 6-7g/dl.
- severe β -thalassaemia/HbE - patients in this group have the clinical severity of thalassaemia major and haemoglobin levels as low as 4-5g/dl. These patients are treated as thalassaemia major patients.

Blood transfusions: Patients with this condition are monitored closely during transfusions, in order to avoid important medical complications such as hypertension, convulsions and cerebral haemorrhage. In order to control high blood pressure, which can lead to deaths from cerebral haemorrhage, anti-hypertensive drugs may be prescribed. Patients who are not suffering severe anaemia should not receive blood transfusions.

α -thalassaemia

The human α -globin genes are duplicated and located on chromosome 16. A decrease in the amount of α -chains

synthesised occurs when a large fragment of DNA involving one or both α -globin genes is deleted.

If one gene is deleted, the individual is described as having the silent or carrier type $\alpha\alpha/\alpha-$

If two genes are deleted, the individual is described as having the trait $\alpha\alpha/--$ or $\alpha-/α-$

If three genes are deleted, the individual is described as having Hb/H disease, as a result of an excess of β -chains - a condition characterised by moderate haemolytic anaemia, splenomegaly (and acute haemolytic crisis in response to a number of drugs and injections).

If four genes are deleted, hydrops foetalis (or Hb Barts) occurs - i.e. death of the foetus in utero.

Chapter 8

Therapeutic regimes - established and future approaches

Bone marrow transplantation (BMT)

Bone marrow transplantation, if successful, can offer a complete cure to patients with thalassaemia major. BMT for thalassaemia started in 1981, with more than 1,500 cases so far treated.

What is a bone marrow transplant?

Bone marrow is the spongy tissue found inside the bones (see 8a), which makes all the cells found in the blood. In adult life marrow is found in the ribs, sternum, skull, hips and spine, but at birth it is also found in other bones. Bone marrow contains 'stem cells' (see 8b) from which red blood cells, white blood cells and platelets are derived.

A bone marrow transplant (BMT) involves taking (harvesting) bone marrow from a healthy individual (called the donor) to be donated to a patient (called the host or recipient). The patient's "unhealthy" marrow is first destroyed by drugs, or sometimes by irradiation, in a process known as conditioning. The healthy marrow, usually taken from the donor's hipbone, is then given as a liquid into the patient's blood stream, in a similar way to a regular blood transfusion (see 8c). Once in the recipient's blood, the donor's bone marrow cells travel to the large bones where they start producing normal, healthy blood cells. This takes about 2-3 weeks.

8a

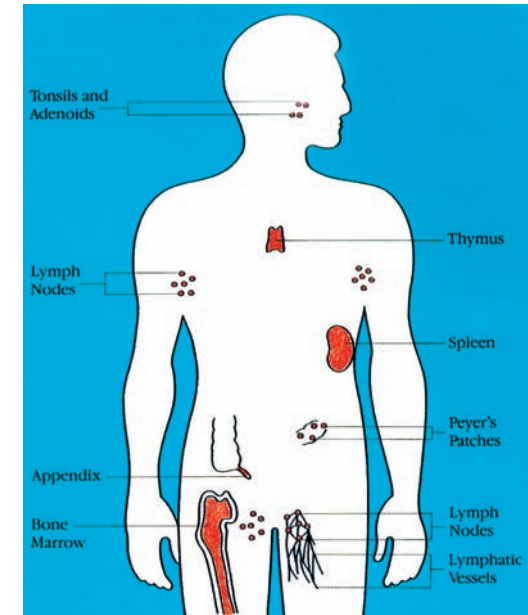

8b

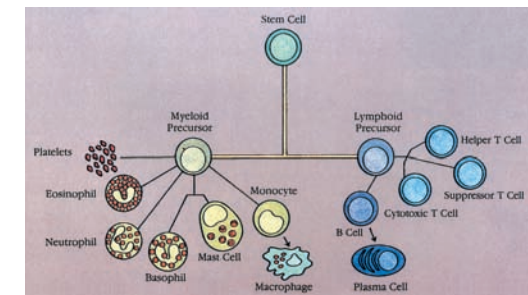

What are the risks?

Although this procedure can be extremely successful, it also carries serious risks. The risks and benefits of each case must therefore be carefully considered before a transplant is carried out. For the best results, bone marrow must be given from a brother or sister who is a complete tissue 'match'.

Complications include infection and bleeding, which usually occur before the donor marrow has replaced the marrow of the recipient. A further complication is graft versus host disease (GVHD), when the donor marrow recognises the patient as 'foreign', causing problems in the skin, gut and liver that can be mild, serious or fatal.

Experts report that problems related to thalassaemia such as iron overload, chronic hepatitis, heart and endocrine problems are much more easily managed after BMT, while damaged organs may even sometimes heal. However, patients must continue to be very carefully monitored throughout their lifetime. After BMT, excess iron accumulated in the patients body before the transplant will need to be removed. This can be achieved by chelation, or more simply by removing blood every 1-2 weeks. Typically, 6ml of blood per kg body weight can be removed from a vein every 14 days or so.

It is important to understand that BMT only treats the bone marrow. So patients planning a pregnancy should be reminded that their genes remain affected by thalassaemia and that any affected genes will still be passed on to their children.

How can the risks be minimised?

- a) Choice of donor. The most important way to keep the risk small is to have an exact match of the patient's tissue type with that of the donor.

The ideal donor - one that will absolutely match a recipient's HLA - is a twin sibling. The second closest match is a sibling whose HLA characteristics are as close a match as possible to those of the recipient brother or sister. The chance of finding a match from a brother or sister is 1 in 4 (25%). It is very difficult to find a match outside the family.

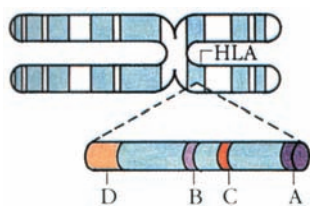

The genes that determine tissue type are called Human Lymphocyte Antigen (HLA) genes, which refer to tissue types expressed on white cells. Among these antigens, HLA-A, HLA-B, HLA-C and HLA-DR play the most important role in matching for BMT. There are 59 antigens at HLA-A site, 118 at HLA-B, 36 at HLA-C and 137 at HLA-DR. The whole system contains several more HLA loci and over 500 genes, producing several thousand million possible combinations in any given population.

However, because these genes are linked and inherited as sets, brothers and sisters inherit one of two sets from each parent, giving a 25% chance of the sets being the same. The overall chance of having at least one brother or sister who is a match but does not also have thalassaemia major will depend on the size of the family. On average, only about 30% of patients seeking to undergo BMT will find a fully matched related donor.

The difficulties of trying to match marrow from unrelated (non-family) donors are, as may be imagined, even greater. Theoretical calculations suggest that the HLA profile of any one individual differs from another, unrelated individual by a factor of one thousand million. It is important to secure an absolute match of donor and recipient bone marrow as the chances of success are significantly reduced when the match is poor. Therefore only after attempts to find a match amongst first-degree relatives and close family members are exhausted is a search undertaken for an unrelated donor. In addition, the donor must be at least three years old, in order that their bone marrow function has matured.

Over recent years efforts have focused on improving matching techniques, to enable transplants between matched unrelated donors (MUDs) and recipients, thereby drawing on a larger pool of possible donors. Registers have been established, listing the HLA characteristics of donors from all over the world who volunteer to get tested, along with their names and addresses. As soon as a recipient with an acceptable HLA match is found, the donor can be informed and the transplant

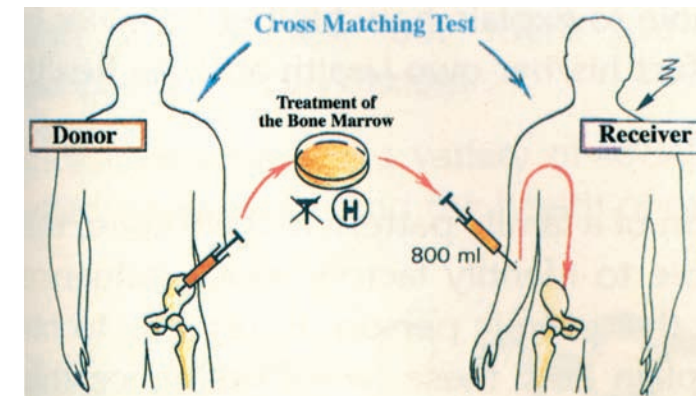

8c

carried out. The idea of developing registers of unrelated donors first emerged in 1987 and there are now about 3.5 million potential donors listed, mainly on registers in the US and Europe. However, although some work on unrelated donors has already been carried out, more research is needed in order to reduce the risks involved, which are considerably higher than amongst matched siblings.

b) Choice of the recipient (patient). Some patients are at greater risk from BMT than others. Several risk factors have been identified.

- an enlarged liver - larger than 2cm
- liver damage - fibrosis or scarring of the liver
- poor control of iron overload

Based on these factors, patients are classified into three categories, each with a different success rate. Class I has one of the risk factors while class III has all three risk factors.

A further independent risk factor is the age of the patient; results in patients over 16 years of age are significantly poorer than for younger patients (see Table below).

Children (<16y)	number	survival %	event free %
Class I	121	95	90
Class II	272	85	81
Class III	125	78	59
Adults (17-22y)	70	70	66

(Pesaro Experience 1995)

Ideally, a patient undergoing a bone marrow transplant should be under 16 years of age with a healthy liver, little iron overload and a brother or sister who is an exact HLA match. As indicated in the table above, survival rates are lower in patients transplanted above the age of 16.

Other approaches to bone marrow transplantation with an exact match (related)

Doctors are working to improve the success rate and lower the risks of complications associated with trans-

plants from matched unrelated donors (MUDs), matched family members who are not siblings, and mismatched parents. One aspect is to modify the treatment (conditioning) to reduce the risk from the transplant procedure. However, results are rather variable and the risks and benefits need to be considered on a case-by-case basis (see Table below).

Results of BMT from alternative donors in thalassaemia	
•68 thalassaemia major patients aged 2-37y (median 15y) 14 Class I, 16 Class II and 38 Class III	
•Rejection/Failure	13%
•Acute GVHD II-IV	40%
•Chronic GVHD	18%
•Disease-free survival with transfusion independence	65.8% (80% in Class I patients)
•Transplant Mortality	20%
•Overall Survival	79.3% (96.7% in Class I patients)

[La Nasa, G., et al. An. N.Y. Acad. Sciences, 2005]

Conclusion

Bone marrow transplantation from a fully matched sibling offers a high chance of cure with a risk of procedure-related mortality as low as 5% in well-selected patients. Work to reduce the risks from transplantation still further is continuing, including improving the outcome of transplants from donors who are not fully matched siblings.

Cord blood transplantation

Another transplant technique involves testing the HLA characteristic of a foetus carried by a mother who has an affected child. If the foetus HLA matches that of the older child, cord blood - the blood remaining in the placenta and umbilical cord after the birth of a baby, which is a rich source of the stem cells responsible for producing blood cells - can be transplanted into the affected child instead of bone marrow. However, an important limitation to this technique is that the donor's cord blood must contain a minimum number of nucleated cells (>1x10⁷) per kg of the recipient's body weight.

Chapter 9

In addition, as with BMT, the recipient's liver, kidney, heart and lungs must be functioning adequately.

The first successful cord blood transplantation was carried out more than ten years ago. Since then, 500 such operations have been performed worldwide. The technique has also been successful in curing some patients with thalassaemia major. However, further research is needed to improve success rates.

Cord Blood Transplantation in thalassaemia	
	Number of Children
Transplanted	44
Living	44
Disease-free	36
Transplant Rejection	8
Acute GVHD II	4
Mild Chronic GVHD	2

[Locatelli, F., et al. Eurocord, 2003]

Possible advantages of this type of transplantation are:

- cord blood is relatively free of infectious micro-organisms
- may be a lower risk of graft versus host disease (GVHD) because the T-lymphocytes that cause GVHD are not completely functional at birth (this has yet to be confirmed in thalassaemia patients)
- a lower levels of HLA matching may be required than in conventional BMT

So far there are insufficient results to show whether these possible advantages are realised with improved results.

Work is now underway to establish a network of cord blood storage centres, similar to the current system of volunteer blood banks. Given appropriate treatment, cord blood can be stored at -19°C for 20 years. The largest cord blood bank is the New York Blood Center, with more than 7,000 samples collected and from which more than 200 transplant cases have benefited. It currently costs about US\$28,000 to obtain and transplant cord blood from the New York Blood Center. Germany, France, the UK, Italy, Belgium, the Netherlands and Spain have also developed cord blood banking services.

Other approaches to treatment

Foetal haemoglobin inducers

Scientists are continually exploring other ways to cure thalassaemia - preferably non-invasive means, with less risks and lower costs than current methods. Most new approaches have focused on reducing the imbalance between the globin chains. For example, a number of drugs have been identified that can increase the production of other types of chains such as γ -chains, which, when coupled with α -chains, form foetal haemoglobin HbF ($\alpha^2 \gamma^2$), so reducing the amount of free α -chains. These drugs suppress the activity of the bone marrow and stimulate the production of γ -chains, and include 5-azacytidine, cytosine arabinoside, hydroxyurea, erythropoetin and butyric acid derivatives. Both 5-azacytidine and cytosine arabinoside demonstrated toxic effects in patients with thalassaemia and work using these drugs has since been discontinued although newer, less toxic derivatives are being investigated. Some success has been seen with hydroxyurea and erythropoetin, although so far with greater benefit to patients with thalassaemia intermedia than those with thalassaemia major.

The role played by butyric acid derivatives in stimulating γ -chain synthesis is not yet fully understood. However, the most effective of the butyrates is arginine butyrate, which is administered by intravenous infusion. Some patients respond better than others to this treatment, for reasons that, again, are not yet fully understood. Future progress may lie in using a combination of either arginine butyrate and hydroxyurea or arginine butyrate and erythropoetin, or all three drugs together.

In the case of thalassaemia major the aim of using these drugs is to prolong the interval between blood transfusions, while in thalassaemia intermedia the aim is to avoid or delay the need for transfusion therapy and reduce bone pain associated with expansion of the bone marrow.

Gene therapy

A final cure for thalassaemia major requires the transfer of healthy genes into the stem cells of the bone marrow - an approach called gene therapy. Over the last 10 years, there has been tremendous progress in developing biological systems capable of carrying this healthy gene into a patient's stem cells. In more recent years, viral microorganisms (retroviruses) have been used with promising results. However, an important problem with these methods is ensuring that the β -chains produced as a result of the healthy gene introduced are of sufficiently high quantity and quality over the long term.

In addition concerns have been raised over the safety of introducing viruses and of possible interference with other genes.

Pre-implantation diagnosis with HLA-matching

In recent years, research has also focused on a technique known as pre-implantation genetic diagnosis or PGD, in which the HLA of an affected child is matched with that of a fertilised HLA-matched egg, free of thalassaemia which is then implanted in a woman's womb. The new child will be able to provide its sibling with an exact match for a bone marrow transplant. Such methods though raising important ethical issues, offer new hopes for cure. In addition, these methods are extremely costly and technologically demanding. However, rapid advances mean the technique could be more widely available in the near future.

Chapter 10

Psychosocial issues

The patient

As with any other chronic illness, patients with thalassaemia major face considerable challenges. The physical demands of the disease, as well as a lack of public awareness in many affected countries, mean that both patients and their parents and families experience emotional difficulties in trying to cope with thalassaemia. At various times in their lives, patients may experience many emotions, such as:

- Frustration • Disappointment • Grief • Hostility
- Depression • Anxiety • Fear of death • Lack of confidence
- Isolation • Anger • Helplessness • Feelings of being unloved • Mistrust • Feelings of being overprotected
- Low self-esteem and many others.

On the other hand, patients also experience other, positive, emotions, such as courage and a sense of challenge and endurance that help them to mature more rapidly and to become more creative, brave, patient and trustful.

The parent

Similar negative and positive emotions are experienced by the parents who in addition may feel responsible or guilty for their child's health condition. Most are in shock when their child is first diagnosed. In countries with very little or no knowledge about the disease and its treatment, parents are also unprepared for the intensive home care that is an essential part of their child's long-term prognosis. A diagnosis of thalassaemia may also place considerable strain on a couple's relationship, sometimes leading to separation or divorce. On the other hand, the illness may also bring parents closer together, determined to protect and support their child. Equally, however, parents may focus a great deal of their attention on caring for the child diagnosed with thalassaemia,



putting a strain on relationships with other members of the family, particularly other children.

Patients and parents

The feelings experienced by both patients and parents, combined with the painful reality of long-term treatment that goes far beyond blood transfusion and iron chelation, can often lead to behavioural problems. As a result of the social stigma attached to thalassaemia and other genetic hereditary diseases, many parents may be unwilling to discuss the diagnosis with others, keeping it secret even from close family members. Even now, in countries where the level and quality of public awareness is high and clinical advances have increased the life expectancy and quality of life of patients with thalassaemia, patients and parents and often the whole family still experience these feelings - at least until they learn to accept that they are going to live with thalassaemia, learn how to cope with the disease. A period of grieving by both parents and patients is therefore expected, and should be allowed until strong negative emotions subside and the disease and its care become integrated into their everyday life. The support of professionals during this period may be extremely valuable.

The sad part of the story, however, is seen in affected countries with limited resources where patients and parents learn about the disease and its treatment and realize their very limited opportunities to address the problem. This leads to life-long distress, despair, frustration, depression and social isolation. Patients in these countries die at very young ages, often undiagnosed or misdiagnosed, and inappropriately treated or not treated at all.

Getting information and support

It is important for parents with an affected child to search for as many sources of information as possible about thalassaemia - in libraries, on the Internet, and from other parents who have children with thalassaemia.

National Thalassaemia associations and the Thalassaemia International Federation can play a key role, providing parents with an important source of information and support, helping to strengthen their confidence in helping their child to live and live well with the disease. Parents who are well informed about the disease, its treatment and prevention are best able to support their child and to avoid, if they wish, having a second affected child. Doctors are a very important additional source of information, as well as of guidance and reassurance. The role of the nurse is also pivotal. In some cases, the nurse/patient relationship may be different to that of the doctor/patient. Due to the often lengthy and regular periods of time spent with the patient, the nurse may often be the first one to pick up on specific problems a patient may be experiencing. Furthermore, due to the informal surroundings of the transfusion unit, the nurse frequently comes into contact with the patient's family and friends, the people most likely to be aware of treatment difficulties the patient may have. Often these people will volunteer such information more readily than the patient. It is essential, however, that this information is relayed back to the doctor so that treatment changes can be made.

One of the most important areas of the doctor's and nurse's role concerns treatment compliance. Many parents and patients suggest that the most difficult aspect of the medical care in thalassaemia major is beginning iron chelation therapy. Having successfully adapted to monthly transfusions, patients and parents are now faced with yet another hurdle. The medical and nursing staff can often ease this transition considerably, resulting in a more relaxed and successful treatment programme.

The infant child, the adolescent and the adult patient with thalassaemia major

The infant patient - In the early years, a child feels the pain and discomfort of treatment for thalassaemia, even though he or she will not understand what is happening to him/her. However, this is also the time a child develops



trust and confidence in whoever takes care of him/her. It is therefore crucial that parents accept the situation as early as possible and begin to build a strong, healthy relationship with the child that includes helping it through treatment.

Difficulties tend to emerge more clearly in toddlers, when the child begins to seek greater autonomy, doing things by itself and taking initiative. It is at this point that the child begins to understand that it is restricted in what it can do and - perhaps more pointedly - cannot do what other children of its (his/her) age do.

When the child reaches school age, the situation becomes more difficult. In addition to the pain and complications of treatment, an awareness of being different - particularly of looking different, when patients have experienced bone changes and/or delayed growth due to late start of or inappropriate medical care - can have a serious, detrimental effect on a young patient's sense of well being. It is at this stage that patients tend to be most forceful in demanding explanations. Here, parents and physicians play an important role in explaining the disease and, very importantly, in encouraging the child to feel confident. If they succeed without being overprotective (particularly in the case of parents), leading to other negative aspects, the seeds will have been sown for a confident child to grow into a confident adolescent and a confident adult.

Adolescence - This is perhaps the most difficult period - a time when young people are particularly vulnerable as they negotiate the difficult transition from youth to adulthood. It is often at this time that the prospect of a lifetime spent managing thalassaemia becomes most stark but it is also the time the patient needs to recognise that he/she has the power to control his/her quality of life.

Rebelling against required behaviour is just as normal amongst teenagers with thalassaemia as it is amongst other teenagers. But for patients with thalassaemia, the risk is that that rebellion will take the form of refusing to comply with treatment, particularly iron chelation therapy. Parents, siblings and medical staff, including doctors, nurses and psychologists, all play a crucial role in providing support to teenage patients with thalassaemia to feel

confident and happy and to comply to treatment, reminding them of the dangers of not carrying out their doctor's recommendations. Some doctors use examples of happy, healthy and successful older patients who comply with treatment, in an effort to encourage and support teenage patients.

Adulthood - Once into adulthood, patients face new challenges. Of course, by adulthood, patients have often developed the additional confidence and hope they lacked as children. Like their parents and family, patients will have become stronger and wiser, themselves serving as examples to younger patients and their families. Nonetheless, as patients begin to make lifestyle and career decisions, perhaps moving into long-term relationships or considering higher education, employment, marriage and the possibility of starting a family, the demands of treatment can become particularly irritating. Patients therefore continue to need strong encouragement to keep to treatment regimes - for themselves and for those around them. Additional strains also emerge if a patient finds out that he or she is unable to become a mother or father.

Concerns about mortality continue to be a major source of distress, particularly in adult patients who are more aware of the medical complications of the disease and who may have lost friends to the disease. Each of the challenges appearing at different ages and times requires the constant support and encouragement of family, friends and medical staff and very importantly, the positive attitude and effort of patients themselves. How well, confident and mature a patient with thalassaemia major grows to be is related to the level of support he/she receives - as well as the realization that without the patient's own active involvement, no battle can be won. Provided that appropriate treatment is available and affordable and adequate support is provided, most patients are able to counteract to a great extent the negative aspects of living with a chronic disease, and can fulfil almost all their ambitions and make their wishes and dreams come true.

Unfortunately, most of the countries heavily affected with thalassaemia are in the developing world, where the support the national health authorities, parents and



Chapter 11

medical staff can provide to patients is constrained by very limited resources, poor health structure and other health priorities.

One very important role of TIF is the promotion of national thalassaemia associations and the provision of constant encouragement and support to national health authorities of affected countries, in order to make them recognise the problem and the tremendous impact this disease will have on their public health if not appropriately controlled.

Additional information

Survival and quality of life

Dramatic improvements in the clinical management of thalassaemia major over the last 10-20 years have led to an impressive increase in the lifespan and quality of life of patients who can access -- or afford -- and comply to recommended treatment regimes. However, even in countries where appropriate clinical care is available to every patient, iron-related complications remain the main cause of death amongst patients with thalassaemia.

In both the industrialised and the developing world, compliance to iron chelation therapy with DFO is a determining factor in patient survival. But while in developing countries the problem most patients face is being able to access and/or afford desferrioxamine, in developed countries where the drug is easily available to patients, the problem is ensuring that patients stick to the difficult and painful treatment regime and use desferrioxamine as often as they should.

Research published in 1996 by A. Piga et al indicates that survival rates are highest where patients receive more than 225 DFO infusions per year, with patient life span becoming progressively shorter the fewer infusions of DFO are administered. The importance of ensuring that patients adhere to iron chelation therapy means medical staff, parents and families have an important role to play in supporting and encouraging patients.



(Photograph of a patient with permission)

Author patients	Year	No. of DFO-chelated patients	Survival in hypertransfused and
Modell et al	1982	92	25% at 25 years among UK patients born after 1963 and treated at both specialist and non-specialist units; better survival among those who received mean DFO dose >4g/week

Author	Year	No. of patients	Survival in hypertransfused and DFO-chelated patients
Zurlo et al	1989	1087	84.2% at 15 years in 1965-69 birth cohort v 96.9% at 15 years in 1970-74 cohort; patients treated at 7 specialist centres
Brittenham et al	1994	59	100% at 25 years in well-chelated patients v 32% at 25 years in poorly-chelated patients born between 1963 and 1987; periodic follow-up by specialists in a single centre
Olivieri et al	1994	97	91% in best-chelated group v 18% in worst-chelated group after 15 years of therapy; patients treated at 3 specialist units
Giardina et al	1996	88	Median survival of 29 years in patients born after 1963 and treated at a single specialist centre
Piga et al	1996	257	66% at 25 years in patients born between 1958 and 1993 and treated at a single specialist centre
Borgna-Pignatti et al	1998	1146	82% at 25 years in patients born between 1970 and 1974 and treated in 7 specialist centres
Modell et al	2000	796	50% mortality before the age of 35 years among UK patients treated at both specialist and non-specialist units
Davis et al	2001a	103	78% at 40 years for full cohort born 1957-97 and 100% at 25 years in patients born after 1974; patients treated at a single specialist unit in UK
Borgna-Pignatti et al	2004	977	The survival and survival without complications in patients with thalassaemia major continue to improve, particularly in female patients who were born just before or just after iron chelation therapy has become available in the market
Telfer et al	2006	539	The majority of patients, who were born after 1974, have an average survival age of 30 years. There is a considerable increase in the survival rate of patients from all age groups, due to the introduction of the combination chelation therapy (Desferrioxamine-deferiprone) in the protocols for the clinical management for thalassaemia major that are practised in Cyprus

(Advances in experimental medicine and Biology volume 509, p125)

The table above lists the results of most studies on survival in thalassaemia major undertaken over the last 20 years. This data indicates that, people with thalassaemia major who have been well treated from the start, mainly those born after 1974 when knowledge on the best use

of DFO began to emerge, and are still receiving and complying to appropriate treatment have a very good chance of long survival and a good quality of life. A key factor in the improvement of service and quality of life of patients with thalassaemia major in many countries has been the establishment of a dedicated reference medical centre where patients can receive the best quality treatment. Unfortunately, however, a good deal of work remains to be done in a number of developing countries in order to raise standards of clinical care for patients with thalassaemia.

Other questions that may be of concern to patients and/or their parents are those concerning marriage, family, nutrition and physical activities.

Diet and thalassaemia

In general, patients with thalassaemia need not follow a special diet. Patients should, however, avoid food rich in iron. It is also wise to avoid alcoholic drinks, or to drink only moderately, because the liver is especially vulnerable in thalassaemia -- both because of the level of liver iron stores, and the possibility that patients have been exposed to hepatitis (read more about nutrition in the special section).



Sport and thalassaemia

Thalassaemia patients can take part in most sports -- how often and what type of sport depends on the patient's clinical condition and the doctor's advice should be sought.

Holidays and thalassaemia

TIF has compiled a list of medical experts and medical centres around the world (available from the TIF website) that can provide treatment to patients with thalassaemia major. Before travelling, patients should establish the location of the medical centre nearest to their destination and could also make contact with the local treating physicians of the centre before leaving home. Patients should also ensure they receive all necessary vaccinations (always in consultation with their doctor) before visiting a country and are aware of any specific infections prevalent in the area they plan to visit (see travel advice issued on the WHO website). All medicines required for the patient's treatment regime, including antibiotics and sterile equipment, should be carefully packed and carried with them in their hand luggage.



(Photograph with permission)

Chapter 12

Epidemiology and prevention of thalassaemia

Epidemiology

Thalassaemia was originally thought to be a disease limited to the Mediterranean region, however it is now known that it occurs widely throughout many parts of the world. Thalassaemia has been identified across southern Europe from Portugal to Spain, Italy and Greece, as well as in a number of central European countries and parts of the former Soviet Union. Thalassaemia also affects the Middle East through to Iran, Pakistan, India, Bangladesh, Thailand, Malaysia, Indonesia and southern China, as well as countries along the north coast of Africa and in South America.

Thalassaemia is particularly prevalent in areas in which malaria is or was once endemic (see 12a). The malaria parasite is an infectious agent carried by the anopheles mosquito, enters the human body through a mosquito bite and causes disease in humans by attacking the red blood cells (see 12b). It is thought that in areas where malaria was endemic, humans underwent a small genetic adjustment which gave them an advantage over those in whom this change did not occur. This is because important changes occurred in the environment of the red cells following this genetic change that did not allow the parasite to survive and multiply. This adjustment leads to β -thalassaemia minor or β -thalassaemia trait.

It is believed that as with α -thalassaemia and sickle cell disease carriers of the β -thalassaemia trait were better able to survive malaria than healthy individuals, the number of carriers increased significantly over the years in malaria-endemic regions of the world as large numbers of healthy individuals died as a result of severe malaria infection. Although malaria eradication programmes in recent years have led to a steep fall in the incidence of malaria in many parts of the world, tackling thalassaemia and other severe haemoglobin disorders nonetheless remains a considerable challenge.

Population migration and intermarriage between different

Patients planning to visit high mountain areas should have normal haemoglobin levels and should give themselves time to acclimatise to higher altitudes. Patients may therefore consider restricting themselves to heights not greater than 11,000 feet, or make sure they have a transfusion immediately before travelling to higher altitudes. Otherwise, there are no restrictions on where a patient may travel.

Marriage and family

Patients with thalassaemia major can certainly marry and have children. Whether their children will be healthy will depend on the thalassaemia status of their partner -- i.e. whether they are healthy, a carrier or a patient themselves. If a patient marries another patient with thalassaemia all children born will be affected. If a patient marries a carrier of β -thalassaemia 50% of the children will be affected and 50% will be carriers. On the other hand if a patient marries a non-carrier then all (100%) children born will be just carriers.

In short, patients who comply with recommended treatment regimes can live a near perfectly normal and happy life. In Cyprus, for example, 83% of thalassaemia patients have completed higher education, while 25% have graduated from university. Twenty-two per cent (22%) of patients are married, 73% of which have children -- some of them three or four.

Seventy-nine per cent (79%) of patients in Cyprus work - in handicrafts and agriculture, as secretaries and teachers, and as nurses, medical or paramedical staff.



(Photograph of a patient with her healthy child with permission)

12a Countries affected by malaria before establishment of control programmes



12b Malaria parasites (trophozoites of P. falciparum in red cells)

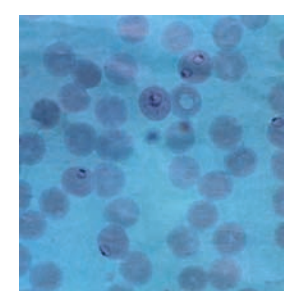

ethnic groups has introduced thalassaemia in almost every country of the world, including northern Europe where thalassaemia did not previously exist and where now it is becoming a major public health problem.

While reliable sources estimate that about 1.5% of the global population -- 80 million-90 million people -- are carriers of β -thalassaemia, with about 60,000 affected children born annually, the great majority in the developing world, it is certain that these figures are gross underestimates: there is still little accurate data available on carrier rates (gene frequencies) in many population groups, particularly in areas of the world known or expected to be heavily affected. According to TIF records, however, only about 200,000 patients with thalassaemia major are alive and registered as receiving treatment around the world -- underlining the bitter reality that the majority of affect-

ed children, born in developing countries, die undiagnosed or misdiagnosed, receiving sub-optimal treatment or left untreated altogether.

The map (see 12c) indicates countries affected by β -thalassaemia. Together with other severe haemoglobin disorders such as sickle cell and HbE/ β -thalassaemia, about 5% of the world's population is affected by such diseases.

12c

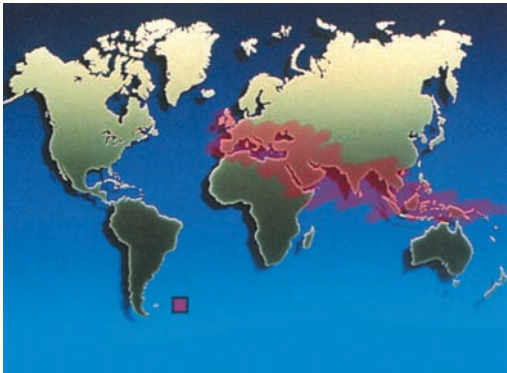

(From TIF's "Guidelines for the Clinical Management of Thalassaemia")

12d

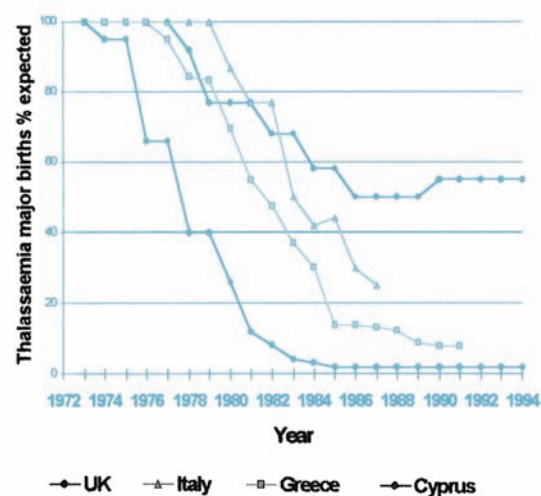

Prevention

Thalassaemia is a preventable disease -- a fact well demonstrated by countries such as Italy, Greece and Cyprus, which were amongst the first to establish successful national programmes, significantly reducing the births of affected children, in some cases to almost none. By contrast in the UK, where quality prevention programmes have been available for some time but where there was no national policy aimed at prevention, the rate of births of affected children has fallen by only 50% (see 12d).

(WHO/HGN/WG/00.1 2000)

Key aspects of the most successful prevention programmes now form the basis for programmes in other affected countries. These are:

- Securing government will and commitment
- Establishing powerful health education campaigns, raising:
 - Public and health professional awareness
- Establishing quality laboratories for:
 - Screening and
 - Prenatal diagnosis and
- Promoting genetic and obstetric services

The importance of prevention

According to the World Health Organization, the annual cost of a nationwide prevention programme in most countries is approximately equal to the cost of treating one annual birth cohort of patients for one year. Annual prevention costs are effectively constant while annual treatment costs rise year-on-year (see fig A), so that the cost-effectiveness of a prevention programme increases with every year it is in place. World Health Organization projections of treatment costs have shown that without prevention programmes to limit the number of births of affected children, most countries will be unable to afford to provide optimal treatment to all patients with thalassaemia. An effective prevention programme is therefore essential in order to meet the cost of treating existing patients (Fig A).

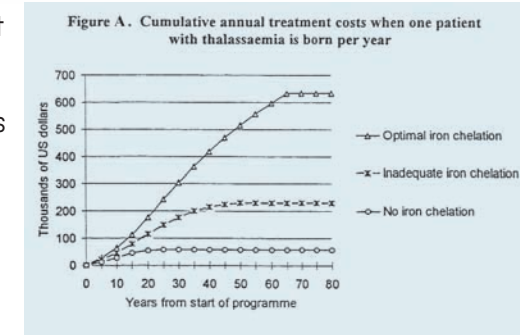

(WHO/HGN/WG/00.1 2000)

How thalassaemia is inherited

As mentioned in Chapter 1, the β -thalassaemia trait is passed from parents to children by an autosomal recessive pattern of inheritance. When a child is conceived, it inherits one β -globin gene from each parent. When both parents carry normal or "healthy" β -globin genes, the child will inherit two normal β -globin genes, as shown.

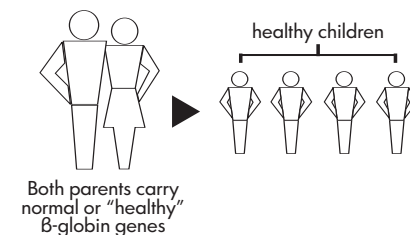

When one of the parents carries an affected β -globin gene -- i.e. when he/she is a β -thalassaemia carrier -- and the other parent carries a normal healthy β -globin gene, each child born to these parents has a one in two or a 50% chance of inheriting the affected thalassaemia

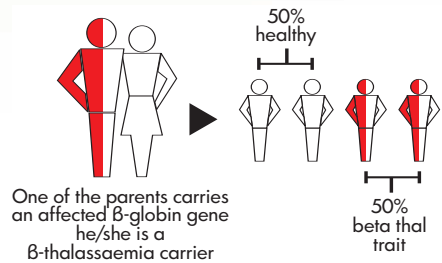

gene from the carrier parent, as shown. These children are known as:

- (i) carriers of the β -thalassaemia trait or
- (ii) individuals heterozygous for β -thalassaemia or
- (iii) individuals with β -thalassaemia minor.

About carriers of the thalassaemia trait

Carriers of the thalassaemia trait do not have a disease. They have no physical or mental symptoms and do not require a special diet or medical treatment. The condition cannot become a serious disease over time -- indeed, most will be unaware that they are carriers unless specifically tested. However, some carriers may experience mild anaemia, which may be inaccurately diagnosed as iron deficiency anaemia. Laboratory tests can easily differentiate between the two. Pregnant women carriers may experience moderate anaemia which is addressed by prescribing iron supplements during pregnancy.

Why it is important to know if you are a carrier

Although being a carrier of the thalassaemia trait has no adverse health effects, if a carrier has a child with another carrier, there is a one in four or 25% chance that that child will have thalassaemia major.

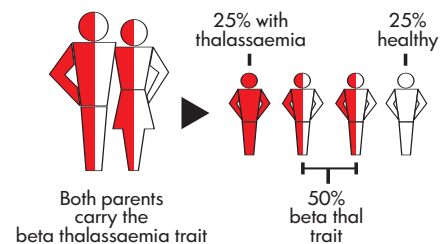

As the figure indicates, when both parents are carriers, for every pregnancy there is a one in four (25%) chance that the child will be affected by thalassaemia major, a one in two (50%) chance that the child will carry the thalassaemia trait, and a one in four (25%) chance that the child will be completely unaffected.

Other "abnormal haemoglobins" and haemoglobin disorders

A number of other "abnormal" types of adult haemoglobin have been identified, which differ both in structure and in their clinical outcome. These abnormal haemoglobins are known as structural haemoglobin variants, and they include mainly haemoglobin S (HbS), haemoglobin E (HbE), haemoglobin C (HbC), haemoglobin D (HbD) and haemoglobin Lepore (Hb Lepore). They are inherited in exactly the same way as described for β -thalassaemia. However, only those that inherit Hb Lepore and HbS from both parents have clinically significant conditions, with Hb Lepore resembling β -thalassaemia intermedia to major and HbS causing sickle cell disease -- a severe haemoglobinopathy different from β -thalassaemia major in both its clinical outcome and medical care. No disease is associated with traits for the other abnormal haemoglobins -- HbC, HbD or HbE -- from both parents. However, these variant haemoglobins can combine with the β -thalassaemia trait to produce other related clinically significant blood disorders.

HbE/ β -thalassaemia

HbE is one of the most common abnormal haemoglobins, particularly amongst people of southeast Asian ancestry, such as Cambodians, Vietnamese and Thais.

If one parent carries the β -thalassaemia trait and the other parent carries the HbE trait, there is a 25% chance in each pregnancy that the child will be born with HbE/ β -thalassaemia.

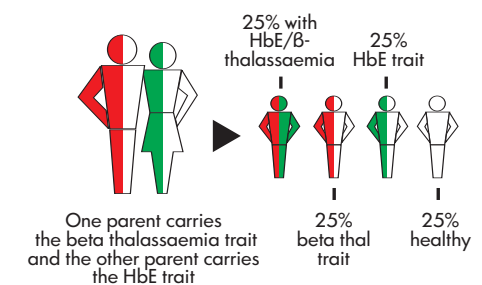

HbE/ β -thalassaemia is a moderately severe anaemia whose symptoms are usually similar to those seen in β -thalassaemia intermedia, but which may be as severe as those seen in thalassaemia major. The clinical outcome and medical care of HbE/ β -thalassaemia is covered in this book.

Hb Lepore/ β -thalassaemia

A combination of Hb Lepore with β -thalassaemia results in a severe clinical condition resembling β -thalassaemia major and is inherited in the same way as the one described above for HbE/ β -thalassaemia.

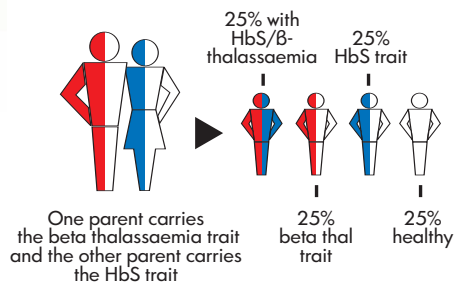

HbS/β-thalassaemia

If one parent carries the β-thalassaemia trait and the other parent carries the HbS trait, there is a 25% chance in each pregnancy that the child will be born with HbS/β-thalassaemia.

HbS is commonly found in people of African or Mediterranean ancestry. The severity of the condition varies according to the amount of normal β-globin produced by the β-gene. When

no β-globin is produced by the β-gene, the condition is almost identical to sickle cell disease. When some β-globin is produced by the β-gene, the condition may be less severe. The information contained in this book does not apply to this condition. More information is available on WHO web sites.

Other combinations of haemoglobin variants may be inherited, such as δβ/Hb Lepore and HbO Arab/β both resembling thalassaemia intermedia, and HbS/HbC, HbS/HbD Punjab and HbS/HbO Arab, all of which resemble sickle cell disease of variable severity.

α-thalassaemia

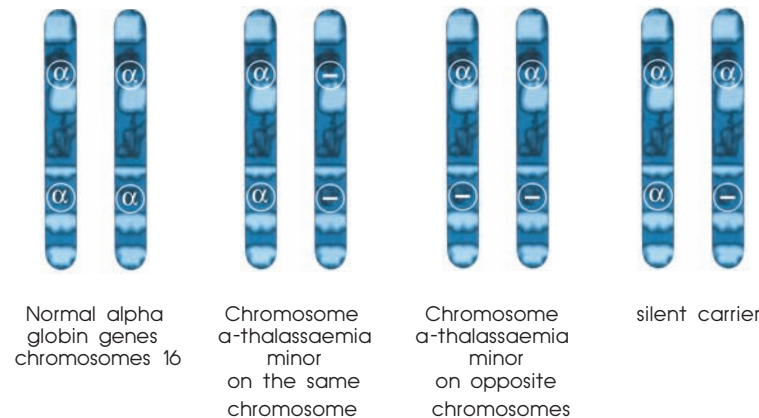

α-thalassaemia is very different from β-thalassaemia; the information contained in this book does not apply to individuals who carry α-thalassaemia. More information about α-thalassaemia is available on the WHO website. However, some basic information, on its epidemiology and ways of inheritance are given on the next page.

There are over 260 million carriers of α-thalassaemia in the world, with the highest incidence in India, southeast Asia and Africa and, to a much lesser extent, in the Mediterranean region; it is very rare in northern Europe.

By contrast to β-globin, α-globin is made up of four genes, two on each strand of chromosome 16.

The α-thalassaemia traits combine in different ways to produce blood disorders that range from mild to severe.

Hb Bart's hydrops foetalis syndrome (see ii) - is the most severe α-thalassaemia, the homozygous state for α⁰-thalassaemia: All four α-globin genes are not functioning and no α-chains are produced. The condition causes severe anaemia leading to the death of the foetus. Although with a wide variation in clinical outcome, individuals with HbH disease (see iii) are in the majority of cases healthy. The only severe form of HbH disease is HbH hydrops foetalis, a quite rare disease.

The importance of α-thalassaemia in the clinical course of β-thalassaemia

The presence of the α-thalassaemia trait is important in patients with homozygous β-thalassaemia, as it can reduce the imbalance between the α- and β-chains and so produce a milder clinical outcome of β-thalassaemia.

Finding out whether you are a carrier

Genetic counselling

In most cases, simple laboratory tests can identify whether a person carries the thalassaemia trait. However, before any laboratory tests are carried out, it is important that individuals receive genetic counselling where possible, providing them with information, advice and guidance on why they should be tested, and what the results of the test will mean for them. Otherwise provision of this information should rely on a good health education programme. A genetic counsellor will be specially trained, able to discuss important aspects of prevention, but also of the disease itself, including:

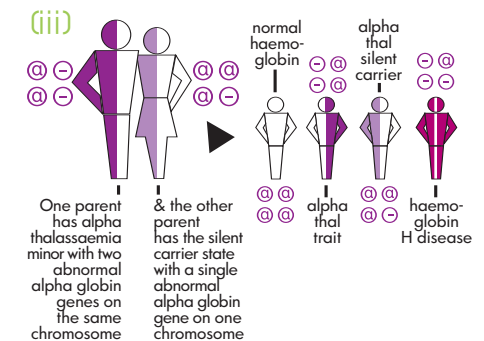
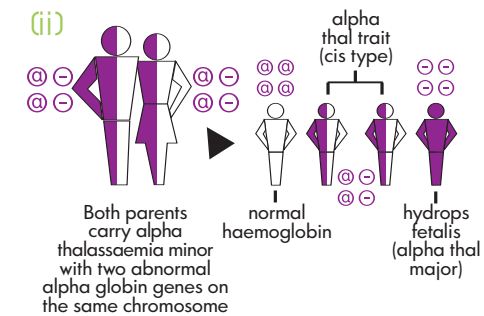
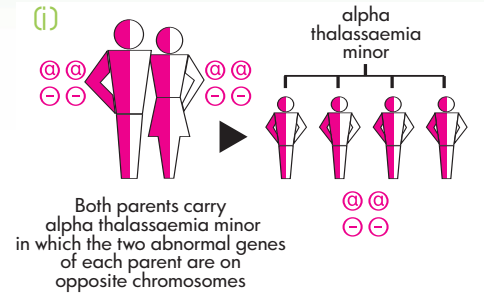

- Where to be tested
- How to interpret test results
- What it means to be a carrier, including options available to two carriers planning to have children, or who have already conceived -- i.e. at-risk couples
- The nature and treatment of thalassaemia major or of any other haemoglobin disorder or genetic disease.
- A counsellor should provide information to individuals and couples, allowing them to decide for themselves how they wish to proceed. However, the advice offered by a counsellor and the decision taken by at-risk couple is often influenced by religious and cultural beliefs. TIF's publication "Prevention of Thalassaemias and other Haemoglobin disorders" Volume I, may offer the reader more expert information on these issues.

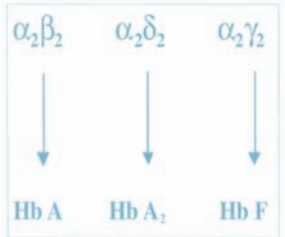

Laboratory testing to establish whether one is a carrier of the β-thalassaemia trait

Laboratory tests for thalassaemia include a routine blood test known as a Complete Blood Count (CBC), which includes measuring the level of haemoglobin and other parameters related to the number and volume of red blood cells, known as Mean corpuscular Volume (MCV) and Mean Corpuscular Haemoglobin (MCH). For example,

Haematological Values commonly found in non carriers (normal) and carriers of β-thalassaemia minor (trait)			
Non-carrier (normal)		Carrier of β-thalassaemia	
Hb:	13.5 g/dl	Hb:	14.2 g/dl
HCT:	42%	HCT:	42.5%
MCV:	88.8 FL	MCV:	61.2 FL
MCH:	28.5 pg	MCH:	20.5 pg
MCHC:	32.1 g/dl	MCHC:	33.4 g/dl
RDW-CV:	13.1%	RDW-CV:	15.9%
		A2:	5.3%

in adults, an MCV of less than 75 may be indicative of a carrier state (alternatively, it may indicate iron deficiency -- a further test will establish which is the case). MCV levels may be lower in children and vary according to age. Red

blood cells are also examined under a microscope in order to examine their size and shape. The red blood cells of a thalassaemia carrier will be a paler shade of red and be various shapes (poikilocytosis), (see 12f) compared to normal red blood cells which are a darker red and round and concave in shape (see 12e).

FORMS OF β-THALASSEMIA TRAIT

	Anemia	Microcytosis (MCV<75 fl)	HbA ₂	HbF	Other
"Classical"	0-+	+	>3.5%	1-5%	
βδ	0-+	+	<3.5%	5-10%	
Lepore	0-+	+	<3.5%	1-5%	5-10% Lepore Hb
Silent carrier	0	0	<3.5%	<2%	

If further laboratory tests (such as Total iron binding capacity (TIBC) and ferritin) exclude iron deficiency, as the cause of a lower MCV, additional tests are carried out to confirm the presence of the thalassaemia trait and to determine its type. Tests to determine the presence of the β-trait include a process known as haemoglobin electrophoresis, which enables quantitative measurement of HbA and HbA₂, the main and minor components of adult haemoglobin respectively. Other haemoglobins normally present in adult red blood cells such as foetal haemoglobin (HbF) may also be measured by electrophoresis. In most cases, the above tests are sufficient to determine whether an individual is a carrier.

The presence of the α-thalassaemia trait is usually identified by a process of exclusion or deduction: people who have low MCV (not due to iron deficiency), a normal haemoglobin electrophoresis that does not identify the β-thalassaemia trait, and who are of the appropriate ethnic origin are presumed to be α-thalassaemia carriers. In some circumstances, DNA tests need to be carried out in order to determine the presence or absence of the β- or α-thalassaemia trait. Such genetic tests are beginning to be more widely used to test for the thalassaemia trait.

Who should have a blood test

Given the importance of preventing thalassaemia and the fact that the disease occurs in virtually every part

(Proceedings from a conference, MA Nov. 14, 1996)

12e Blood film from a non-carrier (normal)

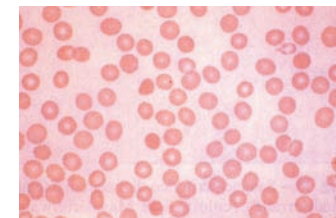

12f Blood film from a β-thalassaemia carrier

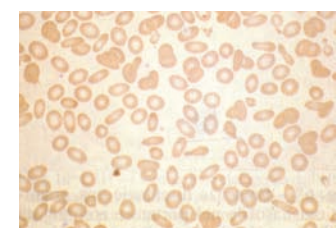

of the world, screening for the thalassaemia trait should ideally be incorporated into a national prevention programme starting at an early age but certainly before marriage or pregnancy, in order to give individuals the greatest choice. At the very least screening should be considered:

- a) when a relative is known to be a carrier or a thalassaemia patient and/or
- b) in countries or when coming from countries known to have a high frequency of thalassaemia

Consanguinity

Consanguineous means having similar blood -- so, for example, a marriage between close relatives is referred to as a consanguineous marriage. In many parts of the world, such marriages are encouraged and practised. However, the closer the relation between the parents, the greater the risk that any children they have may be born with a congenital disorder such as thalassaemia.

An unrelated couple has about a 98% chance of having a healthy child. Couples who are first cousins have about a 96% chance of having a healthy child. First cousins and first cousins whose parents and/or grandparents are also close relatives have about a 94% chance of having a healthy child.

Similarly, the additional risk of having an affected child falls sharply the more distant the relationship between the parents. About 2-3 children in every 1,000 born to unrelated parents have a recessive disorder. From 2-20 children in 1,000 born to related parents have a recessive disorder, depending on how closely the parents are related.

The choices available for an "at-risk" couple

Prenatal testing

Where a woman carrying the β -thalassaemia trait is considering having a child or is already pregnant, her partner (if not aware of his carrier status) should be tested at once to find out if he also has the thalassaemia trait. If they are both carriers, the couple may decide to proceed with planning a family or, if already pregnant, may consider continue the pregnancy and where this is possible, to proceed with testing the foetus for thalassaemia, possibly deciding to terminate pregnancy if the foetus is affected. Other choices considered by "at-risk" couples include separation, adopting, proceeding to invitro fertilization

with foreign healthy sperm or ova. Or parents mainly due to religious beliefs may decide not to find out the status of the child and continue with the pregnancy.

Testing a foetus for thalassaemia

There are three types of tests that can determine whether an unborn child has thalassaemia:

(i) Amniocentesis:

Amniocentesis is performed in the second trimester of pregnancy, after about 15 (18-22) weeks' gestation. Using ultrasound as a guide, a trained obstetrician inserts a very thin needle through the mother's abdomen to withdraw 2-3 tablespoons of amniotic fluid. The foetal cells (cells from the unborn child) present in the fluid are then analysed in the laboratory to determine whether the foetus has thalassaemia.

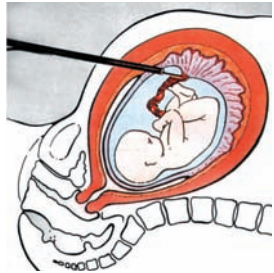

This test is used when the pregnancy is far advanced. It poses no significant risk to the mother. However, the test may cause a miscarriage -- from a few days to a few weeks after the test.

(ii) Cordocentesis

Under ultrasound guidance, a fine needle is inserted through the abdomen into the foetal umbilical cord. About 2-3 ml of blood is aspirated and foetal blood is separated out in the laboratory. In skilled hands 100% pure foetal cells are obtained from the first attempt in the majority of cases. Causes of failure in obtaining pure foetal blood include early gestational age, less than 18 weeks, maternal obesity and posterior placenta. Early gestational age is also the most important cause of occurrence of serious complications in cordocentesis.

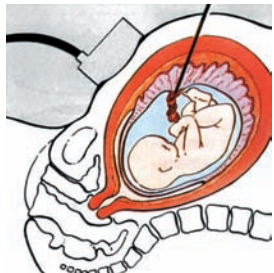

Globin chain separation with gel electrophoresis is the usual laboratory method of detection. Early and specific diagnosis by molecular methods has almost completely replaced cordocentesis which is now mainly indicated only in pregnant patients who report late, in those in whom CVS is inconclusive and when previous studies of at risk couples are not available.

(iii) Chorionic Villus Sampling (CVS)

CVS can be performed somewhat earlier than amniocentesis, at about 10-11 weeks' gestation. Using

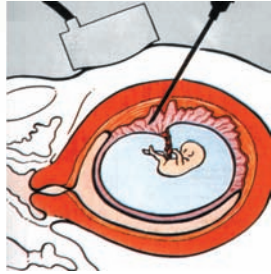

ultrasound as a guide, the specialist obstetrician removes a small sample of the chorionic villi -- cells that contain the same genetic information as the foetus and which will eventually form the placenta. The cells are removed either by a thin needle inserted through the mother's abdomen (transabdominal) or a thin catheter inserted through the vagina (transcervical). The cells are then analysed and a diagnosis made.

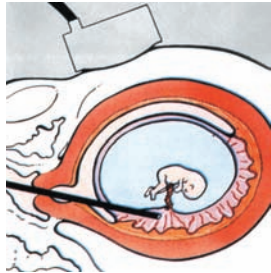

As with amniocentesis CVS poses no significant risk to the mother. However, there is again a small risk of a miscarriage. If a miscarriage does occur, it can be difficult to know whether it was due to CVS, because many miscarriages happen naturally at around 12 weeks of pregnancy.

There may be an increased risk of the baby's limbs being malformed if CVS is done very early in pregnancy - i.e. before the 8th week after the last menstrual period. However, there is no evidence of an increased risk of any malformation when CVS is carried out after the beginning of the 9th week after the last menstrual period. This is why the procedure is generally carried out after the beginning of the 10th week after the last period.

How genetic testing works

Amniocentesis and CVS are both based on DNA testing and involve identifying or excluding the genetic abnormality (mutation) present in parents -- the most accurate means of diagnosing inherited diseases. However, as with all tests, there is a possibility of error, albeit a very small one.

The genes for the characteristics we inherit, including haemoglobin, are made of DNA. Every tissue in the body, including a baby's placenta, contains a person's entire DNA pattern. In the case of CVS, for example, laboratory scientists study the haemoglobin genes contained in the DNA of cells from the chorionic villi to see if the baby will be normal, a thalassaemia carrier or will have thalassaemia major. Analysis of the sample usually takes about a week.

Termination of pregnancy

If the test shows that the baby is affected, the couple may decide to end the pregnancy. The role of the genetic counsellor and the obstetrician in these cases is extremely important. Even at this stages decisions have been taken by the couple to continue with the pregnancy accepting the lifelong treatment of the affected child. If pregnancy termination is the choice, however, this is done in one of the two ways, depending on the stage of the pregnancy.

Early termination

Early terminations can be carried out when a woman is less than 14 weeks pregnant. The couple should be informed that termination does not reduce the woman's chance of having another baby. However, it should also be explained that each pregnancy conceived by an at-risk couple carries the same risk of producing an affected child. If the couple wishes to know whether any subsequent babies conceived carry thalassaemia, prenatal diagnosis will have to be carried out again.

Late termination

The procedure for terminating a pregnancy at over 14 weeks involves inducing labour by introducing hormones (prostaglandin) into the womb. The labour may last for several hours and the procedure is much more upsetting for the woman than an early termination. Again, this type of termination does not affect the woman's ability to become pregnant again.

Other approaches

Prenatal diagnosis and the termination of pregnancy are controversial. Unfortunately, however, prevention cannot rely on the identification of carriers alone and screening cannot be effective and successful in the absence of prenatal diagnosis and pregnancy termination. Other methods of prevention are being developed, such as analysis of foetal cells in the mother's blood. This however has limitations and cannot offer to-date a reliable alternative to classical prenatal testing. Another technique is pre-implantation genetic diagnosis (PGD), which involves the use of DNA technology to select a healthy egg from a woman carrier to be fertilised in the laboratory and then introduced into the womb. PGD may prove more acceptable to those populations opposed to the termination of pregnancy, and may thus become more widely used once the technique becomes less costly and less technologically demanding.

Glossary

agranulocyte	white blood cell without cytoplasmic granules (see granulocyte)
acute	sudden illness with sharp rise and of short duration (compare chronic)
AIDS	(acquired immunodeficiency virus) disease caused by infection with HIV, commonly transmitted through blood or sexual contact
albumin	any of many simple proteins found in blood plasma, muscle, egg whites and milk
aldosterone	a steroid hormone that functions in the regulation of the salt and water balance of the body
alloimmune	production of antibodies against foreign body, for example, donated blood
anaemia	condition in which the blood is deficient in red blood cell, haemoglobin or total volume
anamnestic	second rapid increased production of antibodies in response to an immunogenic substance after serum antibodies from a first response can no longer be detected in the blood
anaphylaxis	hypersensitivity, for example to proteins or drugs, causing anaphylactic shock
antibiotic	substance produced by or a semisynthetic substance derived from a microorganism and able in dilute solution to inhibit or kill another microorganism
antibody	proteins that act against an antigen, as part of the body's immune response
antigen	substance capable of stimulating an immune response
antihistamine	any of a number of compounds used to treat allergic reactions
antioxidant	various substances (such as beta-carotene, vitamin C and alpha-tocopherol) that inhibit oxidation or reactions promoted by oxygen and peroxides that include many believed to protect the body from the effects of free radicals
antipyretics	preventing, removing or allaying fever
antiretroviral	acting, used or effective against retroviruses
antiviral	acting, effective or directed against viruses
arrhythmia	an alteration in the rhythm of the heartbeat, either in time or force
artery	muscular-walled vessel that carries blood from the heart through the body
asymptomatic	presenting no symptoms of disease

autosome	chromosome other than a sex chromosome
bacterium	(pl bacteria) any of a group of prokaryotic (ie without a distinct nucleus) unicellular round, spiral or rod-shaped microorganisms, often grouped into colonies, capable of causing disease
bile	yellow or green fluid secreted by the liver that passes into the duodenum to help absorb fat
biliary	of, relating to or conveying bile
biopsy	removal and examination of tissue, cells or fluids from the living body
blood group	class of blood (A, B, AB or O) into which individuals can be separated according to the presence or absence of specific antigens (also blood type)
blood plasma	pale yellow fluid portion of whole blood consisting of water and dissolved constituents including proteins, electrolytes, sugars, lipids, metabolic waste products, amino acids, hormones and vitamins
blood type	see blood group
bone marrow	"soft connective tissue found in the cavities of most bones, occurring in two forms: whitish or yellowish marrow (yellow marrow) consisting chiefly of fat cells and found mainly in long bones; and reddish marrow (red marrow) where most red blood cell and blood granulocyte production occurs. Also the substance of the spinal cord."
bovine spongiform encephalopathy	"progressive fatal disease of the central nervous system of adult domestic cattle that resembles scrapie of sheep and goats and is probably caused by a prion transmitted through food (BSE; also called mad cow disease)"
capillary	smallest blood vessel
carbohydrate	various compounds of carbon, hydrogen and oxygen including sugars, starches and celluloses, most formed by green plants
carbon dioxide	heavy colourless gas formed in animal respiration and decay or combustion of animal and vegetable matter
cell	smallest structural unit of living matter able to function independently, responsible for all fundamental functions of life
chelating agent	any of various compounds that combine with metals to form chelates and that include some used medically in the treatment of metal poisoning (eg lead)
chelation therapy	use of a chelating agent to bind with a metal in the body, so that the metal loses its toxic effect or physiological activity

chromosome	thread-like structure in the nuclei of cells. They carry inherited information in the form of genes, which govern all cell activity and function.
chronic	illness of long duration, recurring frequently over time, often progressing in seriousness (compare acute)
cirrhosis	widespread disruption of normal liver structure by fibrosis caused by various chronic conditions affecting the liver (such as long-term alcohol abuse or hepatitis)
citrate	a salt of citric acid
coagulation	the process of becoming viscous, jellylike or solid
coagulopathy	a disease affecting blood coagulation
congenital	"existing at birth; acquired during development in the uterus and not through heredity"
contaminate	to soil, stain or infect by contact or association
convulsion	abnormal violent and involuntary contraction(s) of the muscles
Cooley's anemia	(see thalassaemia)
Creutzfeldt-Jakob disease	rare progressive fatal encephalopathy caused by a prion and marked by the development of porous brain tissue, premature dementia and gradual loss of muscular coordination
cyanosis	a bluish or purplish discolouration (eg of the skin) due to deficient oxygenation of the blood
cytoplasm	inorganic and organic substances external to the nuclear membrane of a cell, including membrane-bound organelles such as mitochondria and chloroplasts
deferiprone	brandname for iron chelating drug administered orally, produced by pharmaceutical company Apotex
deoxyribonucleic acid	(DNA) any of various nucleic acids that are the molecular basis of heredity, constructed of a double helix
Desferal	brandname for desferrioxamine produced by pharmaceutical company Novartis-Pharma
desferrioxamine	iron chelating drug
diabetes mellitus	variable disorder of carbohydrate metabolism caused by a combination of hereditary and environmental factors and usually characterised by inadequate secretion or utilisation of insulin, by excessive urine production, excessive amounts of sugar in the blood and urine, and by thirst, hunger and loss of weight
diagnosis	identifying a disease from its signs and symptoms
diastole	passive rhythmical expansion or dilation of the heart cavities during which they fill with blood

DIC	Disseminated Intravascular Coagulopathy
diuretic	an agent that increases the flow of urine
diuretic	tending to increase the flow of urine
DNA	see deoxyribonucleic acid
dyspnea	difficult respiration
electrophoresis	movement of suspended particles through a fluid or gel under the action of an electromotive force applied to electrodes in contact with the suspension
embolise	to lodge in and obstruct
embolism	the sudden obstruction of a blood vessel by an embolus (an abnormal particle, eg air bubble, circulating in the blood) -- compare thrombus
embryo	a developing human from implantation to the end of the eighth week after conception (compare foetus)
endocrine	producing secretions internally, which are distributed around the body by the bloodstream
enzyme	complex proteins that catalyse specific biochemical reactions at body temperature
erythoderma	redness of the skin
erythroblast	red marrow cell that synthesises haemoglobin and is an intermediate in the initial stage of red blood cell formation -- broadly, a cell ancestral to red blood cells
erythroblastosis foetalis (Rhesus or Rh disease)	a haemolytic disease of the foetus and newborn characterised by an increase in circulating erythroblasts and by jaundice, occurring when the system of an Rh-negative mother produces antibodies to an antigen in the blood of an Rh-positive foetus, which cross the placenta and destroy foetal erythrocytes
erythrocytes	red blood cell
erythropoietin	hormonal substance formed especially in the kidney that stimulates red blood cell formation
extravascular	not in a blood vessel
fat	"oily matter that makes up the bulk of adipose tissue; major class of energy-rich food "
febrile	fever
ferritin	a crystalline iron-containing protein that functions in the storage of iron and is especially in the liver and spleen
fibrinogen	plasma protein produced in the liver and converted into a fibrous protein -- fibrin -- in the formation of blood clots
fibrosis	a condition marked by an increase in fibrous tissue

foetal	see foetus
haemoglobin	haemoglobin consisting of two alpha- and two gamma-chains, and that predominates in the blood of newborns and persists in increased proportion in some forms of anemia (eg thalassaemia)
foetus	a developing human from three months after conception to birth (compare embryo)
folic acid	a crystalline vitamin of the B complex used in treating nutritional anaemias
free radical	very reactive atom or molecular fragment
fungus	(pl fungi) any of a group of parasitic spore-producing organisms
gall bladder	muscular sac in which bile from the liver is stored
gall stone	hard mass formed in the gall bladder or biliary passages (also called biliary calculus or cholelith)
gamma globulin	protein fraction of blood rich in antibodies
gene	functional unit of inheritance in DNA or RNA that controls the transmission and expression of traits
genotype	all or part of the genetic constitution of an individual or group
globin	a colourless protein obtained by removing heme from a protein such as haemoglobin
glucose	"sugar that has an aldehydic carbonyl group; a sweet, colourless, soluble dextrorotatory form that occurs widely in nature is the usual form in which carbohydrate is assimilated by animals"
Graft vs Host Disease (GVHD)	condition that results when T cells from donated tissue or organ attack the recipient's cells
gram negative	not holding the purple dye when stained by Gram's stain -- used chiefly of bacteria
gram positive	holding the purple dye when stained by Gram's stain -- used chiefly of bacteria
granulocyte	polymorphonuclear white blood cell (eg basophil, eosinophil or neutrophil) with cytoplasmic granules (see agranulocyte)
gut	alimentary canal or part of it, such as intestine or stomach
haem	deep red iron-containing substance in haemoglobin and myoglobin
haematopoiesis	formation of blood or blood cells
haemoglobin	(Hb) component of a red blood cell containing iron, that transports oxygen from the lungs to the tissues, and consists of four polypeptide chains designated alpha, beta, gamma and delta
haemolysis	disintegration of red blood cells, releasing haemoglobin

haemorrhage	heavy or uncontrollable bleeding
hepatitis	a disease marked by inflammation of the liver
hepatitis A	acute, usually benign hepatitis caused by RNA-containing virus that does not persist in the blood serum and is transmitted by food and water contaminated with infected faeces (also infectious hepatitis)
hepatitis B	sometimes fatal hepatitis caused by double-stranded DNA virus that tends to persist in the blood serum and is transmitted by contact with infected blood or contact with other infected bodily fluids (ie during sexual intercourse)
hepatitis C	hepatitis caused by single-stranded RNA-containing virus usually transmitted by illicit drug use, blood transfusion or exposure to infected blood or blood products and leads in the majority of cases to chronic infections
heterozygote	describes a person whose cells contain 2 different alleles controlling that trait
heterozygous	having the two genes at corresponding loci on homologous chromosomes different for one or more loci
HIV	(human immunodeficiency virus) group of retroviruses that attack the immune system, leading to AIDS
homologous	having the same relative position, value or structure
homozygote	a term used to describe a person whose cells contain 2 identical alleles controlling a specified inherited trait
homozygous	having the two genes at corresponding loci on homologous chromosomes identical for one or more loci
hormone	product of living cells that circulates in body fluids and produces a specific effect
hydrops foetalis	serious and extensive oedema of the foetus
hyperkalaemia	the presence of an abnormally high concentration of potassium in the blood (also hyperpotassaemia)
hyperpotassaemia	(see hyperkalaemia)
corticosteroid	any of a number of adrenal-cortex steroids, used esp as anti-inflammatory agents
hypertension	abnormally high blood pressure
hypocalcaemia	a deficiency of calcium in the blood
hypogonadism	functional incompetence of the gonads
hypoparathyroidism	deficiency of parathyroid hormone in the body;
hypotension	abnormally low blood pressure
hypothalamus	basal part of the diencephalon that includes vital autonomic regulatory centres (eg for the control of food intake)

hypothermia	subnormal body temperature (under 36.6 degrees Celsius)
hypothyroidism	"deficient activity of the thyroid gland; also a resultant bodily condition characterised by lowered metabolic rate and general loss of vigour"
immune system	protects the body from foreign substances
immunoglobulin	antibody (abbreviation: Ig)
in vitro	outside the living body and in an artificial environment
infect	to contaminate with a disease-producing substance or agent (such as bacteria)
inflammation	response to injury marked by redness, heat, pain, swelling and often loss of function
interferon	antiviral molecule produced by cells exposed to virus, bacteria or synthetically manufactured anti-viral drug
intravascular	in or into a blood vessel
intravenous	through a vein
iron	"heavy malleable magnetic silver-white metallic element that readily rusts in moist air and is vital to biological processes (ie transport of oxygen in the body); symbol Fe"
jaundice	a yellowish pigmentation of the skin, tissues and certain body fluids caused by abnormal production and discharge of bile or excessive breakdown of red blood cells
kidney	one of usually two organs found near the spinal column, that excrete waste products of metabolism
leukocyte	white blood cell
liver	large glandular organ -- the largest in the human body -- that secretes bile and changes products contained in the blood that passes through it
lumbar	of or related to the loins
lung	one of usually two organs in air-breathing vertebrates, found in the lateral part of the thorax, used in respiration
lymphocyte	colourless cells originating from stem cells that form cells of lymph and immune system and constitute 20-30% of white blood cells in normal humans
magnetic resonance imaging	noninvasive diagnostic technique that produces computerised images of internal body tissue by applying radio waves to measure the magnetic resonance of atoms in the body (MRI)
malaria	acute or chronic disease caused by parasites in the red blood cells, transmitted from an infected person by mosquito
meningitis	mild disease caused by a virus or life-threatening disease caused by a bacterium, causing fever, headache, vomiting and stiff neck

microbe	microorganism, germ, esp pathogenic bacteria
microorganism	organism of microscopic or ultramicroscopic size
mitochondrion	(pl mitochondria) structure responsible for producing energy for the cell through cellular respiration
mutation	a change in hereditary material
myocardium	middle muscular layer of the heart wall
neurology	study of the nervous system
nucleus	(pl nuclei) cellular organelle of eukaryotes composed of nuclear sap and nucleoprotein-rich network enclosed in a definite membrane, that is essential to cell fuctions
oedema	excess accumulation of fluid
oestrogen	substance (as a sex hormone) tending to promote oestrus and stimulate development of female secondary sex characteristics
oral	taken by way of the mouth
organ	structure consisting of cells and tissues performing some specific function in an organism
organism	a living being, with mutually dependent organs each with separate functions
organomegaly	abnormal enlargement of the organs (eg liver, spleen)
osteoporosis	condition affecting the bones, characterised by decrease in bone mass with decreased density and enlargement of bone spaces producing porosity and fragility
ovary	female reproductive gland, usually a pair
oxygen	colourless, tasteless, odourless gas that constitutes 21 per cent of the atmosphere
oxygenate	to supply with oxygen
pancreas	large gland lying behind the stomach, attached to the duodenum, and secreting digestive enzymes and hormones insulin and glucagon
pancytopenia	an abnormal reduction in the number of red blood cells, white blood cells and platelets in the blood
parasite	an organism living in, with or on a host organism, usually causing the host harm while obtaining benefits from it
parathyroid gland	any of usually four small endocrine glands adjacent to or embedded in the thyroid, that produce parathyroid hormone
pathogen	agent (such as virus or bacteria) that causes disease
pathology	study of the essential nature of diseases and the structural and functional changes produced by them
penicillin	a mixture of relatively nontoxic antibiotic acids with a powerful effect against various bacteria

pericarditis	inflammation of the pericardium
pericardium	conical sac enclosing the heart and roots of the great blood vessels
phenotype	visible properties of an organism produced by the interaction of the genotype and the environment
phosphorous	non-metallic multivalent element that occurs widely in combined form (P)
pituitary gland	small oval reddish grey very vascular endocrine organ attached to the infundibulum of the brain
plasma	fluid part of blood, lymph or milk that is distinguished from suspended material
platelet	the smallest, disklike cells released from the bone marrow into the blood
pneumonia	disease of the lungs caused by infection or irritants
polymorphism	able to assume different forms
prion	protein particle often considered the cause of various infectious diseases of the nervous system
progesterone	female steroid sex hormone secreted by corpus luteum to prepare endometrium for implantation and, during pregnancy, by placenta to prevent rejection of developing embryo or foetus
prognosis	prospect of survival and recovery from a disease
prophylactic	tending to prevent or ward off disease
protein	Large molecules consisting of hundreds of thousands of amino acids linked into long chains.
refractory	resistant to treatment or insensitive to stimulation
renal	in or related to the kidneys
restriction enzyme	any of various enzymes that break DNA into fragments at specific sites in the interior of the molecule and are often used as tools in molecular analysis
retrovirus	any of a group of viruses containing RNA (such as HIV), that infect cells by causing them to replicate the virus RNA in making DNA
ribavirin	synthetic antiviral drug
ribonucleic acid	(RNA)
saline	consisting of or containing salt
secondary amenorrhoea	cessation of menstruation in woman who has previously experienced normal menses
sepsis	a toxic condition resulting from the spread of bacteria
serum	"watery portion of an animal fluid remaining after coagulation; the clear yellowish fluid that remains from blood plasma after clotting factors have been removed by clot formation (also blood serum)"

sign	objective evidence of disease, especially as observed by a physician rather than by a patient or lay observer (compare symptom)
spleen	abdominal organ involved in breaking down red blood cells, filtration and storage of blood, and production of lymphocytes
splenomegaly	abnormal enlargement of the spleen
stem cell	unspecialised cell that gives rise to differentiated cells (haematopoietic stem cells in bone marrow)
stool	faeces -- bodily waste discharged through the anus
streptococcus	genus of bacteria that include important pathogens of humans and domestic animals
subcutaneous	under the skin
symptom	"subjective evidence of disease observed by a patient; broadly, something that indicates the presence of a physical disorder (compare sign)"
synthesis	combination of parts to form a whole, or the production of a substance by the union or degradation of others
syphilis	chronic contagious disease, usually venereal, producing chancres, rashes and systemic lesions
systole	contraction of the heart by which the blood is forced on and the circulation kept up
tachycardia	relatively rapid heartbeat
testis	male reproductive gland, usually a pair (pl testes)
testosterone	a male hormone produced by the testes that is responsible for inducing and maintaining male secondary sex characteristics
thrombocytes	see platelet
thrombophilia	hereditary or acquired predisposition to thrombosis -- a blood clot in a blood vessel
thrombus	a clot of blood formed within a blood vessel and remaining attached to its place of origin -- compare embolus
thyroid gland	large endocrine gland at anterior base of the neck or anterior ventral part of the thorax, that produces hormones thyroxine and triiodothyronine
tissue	group of cells, usually of a particular kind, which with their intercellular substance form one of the structural materials of a plant or animal
TRALI	Transfusion Related Acute Lung Injury
transfuse	to transfer (as in blood) into a vein or artery
ulcer	break in skin or mucous membrane with loss of surface tissue and often pus
urea	main solid component of mammal urine and an end product of protein decomposition.

uric acid	a waste product of the breakdown of nucleic acids in body cells. a small amount is also produced by the digestion of foods rich in nucleic acids such as liver, kidney. most uric acid produced passes to the kidneys which excrete it in the urine.
urine	waste material secreted by the kidney containing urea, uric acid, creatinine, salts and pigments
urticaria	hives
vaccine	a preparation of living or dead microorganisms injected into the body in order to produce or increase immunity to a particular disease
valve	structure able to open and close to stop, start or regulate the flow of liquid (eg blood) through the vein, heart, etc
vein	vessel that carries blood from the capillaries to the heart
viral hepatitis	hepatitis (such as hepatitis A) caused by a virus
virus	any of a large group of submicroscopic infective agents, that can be extremely simple microorganisms or extremely complex molecules capable of causing infections in humans
vitamin D	any or all of several fat-soluble vitamins chemically related to steroids, essential for normal bone and tooth structure
zinc	a bluish white crystalline bivalent metallic element that is an essential micronutrient for both plants and animals (Zn)
zygote	the cell that is produced when a sperm fertilizes an ovum.

(Based on definitions found in Merriam-Webster's Medical Desk Dictionary, Merriam-Webster, Springfield MA, 1996)

Index

- agranulocytosis 59
- anaemia 7, 16, 17, 18, 20, 21, 22, 23, 38, 42, 62, 63, 65, 69, 71, 73, 76, 89, 90, 91, 92, 94, 96, 97, 98, 120, 121, 123.
- blood 1, 2, 3, 4, 5, 6, 7, 9, 11, 12, 14, 15, 16, 17, 18, 19, 21, 22, 23, 24, 25, 26, 27, 28, 29, 30, 31, 32, 33, 34, 35, 36, 37, 38, 39, 40, 41, 42, 43, 44, 45, 46, 47, 50, 52, 54, 55, 57, 58, 59, 61, 62, 63, 64, 65, 66, 67, 72, 73, 74, 76, 77, 78, 79, 80, 81, 82, 83, 84, 85, 86, 87, 88, 90, 91, 92, 93, 94, 95, 96, 97, 99, 100, 103, 104, 105, 108, 117, 121, 123, 124, 125, 126, 127, 129.
- bone marrow 3, 7, 17, 22, 27, 29, 31, 39, 45, 62, 73, 85, 89, 94, 95, 99, 100, 101, 102, 103, 105, 106.
- bone 22, 23, 27, 28, 40, 42, 53, 69, 74, 92, 94, 105, 110.
- cells 1, 2, 3, 4, 5, 6, 7, 10, 11, 12, 14, 16, 17, 18, 19, 26, 27, 28, 29, 30, 34, 38, 39, 41, 48, 49, 58, 59, 62, 63, 67, 69, 72, 77, 82, 83, 84, 85, 86, 87, 90, 91, 93, 94, 95, 99, 100, 103, 106, 117, 124, 125, 127, 128, 129.
- chelation (iron) 21, 41, 42, 44, 45, 46, 48, 50, 51, 55, 58, 60, 62, 65, 66, 67, 68, 69, 70, 73, 74, 77, 78, 80, 82, 89, 93, 100, 108, 109, 110, 113.
- chromosome 10, 11, 12, 97, 122, 123.
- DNA 9, 10, 20, 83, 87, 88, 91, 98, 125, 128.
- Desferrioxamine 42, 46, 47, 54, 55, 56, 57, 58, 61, 68, 69, 73, 76, 77, 113.
- Deferiprone 55, 56, 57, 58, 59, 60, 61, 68.
- erythrocytes 4.
- endocrine 2, 65, 68, 69, 71, 73, 100.
- foetus 13, 16, 84, 98, 103, 123, 126, 127.
- faeces 38.
- ferritin 40, 41, 42, 45, 47, 48, 49, 52, 53, 56, 59, 61, 75, 77, 93, 125.
- granulocytes 33.
- gene(s) 3, 9, 10, 11, 12, 13, 14, 15, 20, 90, 91, 96, 97, 98, 100, 101, 106, 118, 119, 120, 122, 123, 128.
- globulin 4.
- haemoglobin 4, 7, 12, 13, 14, 15, 16, 18, 19, 20, 22, 23, 29, 30, 38, 39, 62, 63, 67, 85, 90, 91, 96, 97, 105, 116, 117, 118, 121, 122, 124, 125, 128.
- hepatitis 24, 39, 45, 59, 65, 77, 78, 79, 80, 81, 82, 83, 86, 100, 115.
- heart 1, 17, 25, 38, 40, 45, 48, 49, 50, 54, 58, 65, 66, 67, 68, 71, 75, 95, 96, 100, 103.
- HIV 32, 77, 78, 83, 84, 85, 87, 88.
- infection 2, 5, 28, 30, 45, 46, 54, 59, 62, 63, 64, 66, 76, 77, 79, 80, 81, 82, 83, 85, 87, 90, 100, 103, 117.
- immune system 2, 3, 31, 63, 80, 83, 85.
- intermedia (thal) 14, 18, 20, 38, 75, 90, 91, 92, 93, 94, 95, 97, 105, 121, 122.
- iron 7, 12, 18, 21, 30, 32, 38, 39, 40, 41, 42, 43, 44, 45, 46, 47, 48, 49, 50, 51, 52, 53, 54, 55, 56, 57, 58, 59, 60, 61, 62, 65, 66, 67, 68, 69, 70, 71, 72, 73, 75, 76, 77, 78, 80, 82, 93, 94, 96, 100, 102, 108, 109, 110, 113, 115, 120, 124, 125.
- lymphocytes 5, 34, 83, 87, 104.
- liver 2, 22, 30, 38, 39, 41, 42, 45, 47, 48, 49, 50, 57, 58, 60, 61, 65, 69, 72, 78, 79, 80, 81, 82, 86, 93, 94, 96, 100, 102, 103, 115.
- MRI 49, 50, 57, 68, 93, 96.
- malaria 20, 24, 30, 32, 86, 117.

Useful Information

Diet and Thalassaemia

Reducing the iron absorbed from food

In thalassaemia, although most of the iron overload is due to blood transfusion, increased absorption of iron from the diet is also important. Only a small amount of iron from the diet is absorbed into our body. The amount absorbed is higher when haemoglobin in the blood is low. People with low haemoglobin such as those with thalassaemia intermedia or those with thalassaemia major not regularly transfused could therefore adapt their diet so that not only the total amount of iron in their diet is low, but also the amount of iron in their body is low. There are two kinds of iron in the diet: iron which is present in red meat (meat iron) and iron which is widely distributed in the diet (non-meat iron).

Meat iron

Meat iron is present in red meat such as beef, lamb and pork and the dark meat of chicken as well as in seafood such as sardines, cockles and mussels. Liver is a very rich source of meat iron. Try to cut down on these and perhaps substitute meat with soy protein. It is not, however, a good idea to exclude meat, chicken and fish completely from your diet because they contain other important nutrients, particularly for children. Choose the white part of the chicken rather than red meat as this contains less iron.

On average, after a meal with red meat, about 35% of iron will be absorbed into our body. However, this may vary between 10-40%, depending mainly on whether the meal contains milk or milk products. The calcium present in milk, cheese, yoghurt and cream decreases the absorption of meat iron. Try to drink a glass of milk with a meat-containing meal and to use milk in cooking. Good examples are the white cheesy sauces in lasagne, pasticcio, mousaka and cannelloni, adding lots of cheese in spaghetti bolognese and using yoghurt and milk to cook your curries.

Milk intake should be at least one pint daily, particularly



neutrophils	5, 59.
osteoporosis	74, 89, 94.
oral (chelators)	55, 61, 64, 80, 82.
overload (iron)	18, 32, 33, 39, 45, 65, 66, 69, 71, 72, 76, 77, 80, 82, 93, 96, 100, 102.
phagocytosis	27.
SQUID	49, 50, 93.
spleen	17, 22, 29, 30, 42, 62, 63, 64, 65, 76, 90.
splenectomy	63, 64, 65.
transfusion	6, 21, 22, 23, 24, 25, 27, 28, 29, 30, 31, 32, 33, 34, 35, 36, 37, 39, 40, 42, 46, 55, 58, 62, 63, 65, 67, 74, 76, 77, 78, 81, 84, 85, 86, 87, 88, 89, 92, 93, 94, 96, 99, 105, 108, 109, 116.
toxicity	32, 41, 45, 52, 55, 56, 57, 58, 60, 69.
urine	2, 38, 41, 50, 56, 57, 58, 61.
viruses	4, 24, 76, 81, 82, 83, 85, 86, 87, 88, 106.

because it also helps to prevent osteoporosis, as will be discussed later. If you are worried about your weight, semi-skimmed milk or skimmed milk are just as rich sources of calcium as whole milk.

Non-meat iron

Non-meat iron is widely distributed in the diet, present in eggs, chocolate, cereals, vegetables, fruits, roots (potatoes, parsnips), beans and lentils. In the UK several foods are fortified with iron, such as breakfast cereals, wheat flour and bread. However, this may not be the case in other countries.

The absorption of non-meat iron from the diet into our body is much less than that of meat iron, but it may vary more than 20-fold, depending on the composition of the meal. The foods that decrease its absorption are: (i) cereals and (ii) dairy products. The foods which increase its absorption are (i) fruit and vegetables rich in vitamin C, (ii) meat, fish, shellfish and poultry, and (iii) pickles, sauerkraut, soy sauce, vinegar and alcohol.

Avoiding taking non-meat-iron is very difficult, because it is present in most foods. However, diet can be modified by taking more of the food that decreases and less of the foods which increase the amount of iron absorbed into our body.

Food that decrease non-meat iron absorption

1. Cereals

Wheat bran, maize, oats, rice and soy decrease the iron absorbed into our body and fight the effect of Vitamin C. Foods rich in vitamin C increase iron absorption. It is good to eat a lot of cereals in your diet, but remember not to take a vitamin C-rich food with them, like orange juice. Try to combine milk and cereals, (e.g., cheese sandwich, French toast, macaroni cheese, cereals and milk). In the UK all wheat flour other than wholemeal is required by law to be fortified with iron. The fortification of breakfast cereals is voluntary. It may, therefore, be better to choose unfortified wholemeal wheat flour and bread and to look carefully at the label of your favourite breakfast cereal. Unfortified breakfast cereals include porridge oats and some cereals in health shops but look at the label to make sure you choose an unfortified variety.



In other countries flour and breakfast cereals may not be fortified.

Soy protein also decreases the amount of iron absorbed into your body. Soy protein can work well in many recipes (e.g., spaghetti bolognese, stews and casseroles) and the taste can be improved by adding spices.

2. Tea, Coffee and Spices

Tea, coffee and some spices (e.g. oregano) decrease iron absorption. Drink plenty of tea and coffee daily, particularly with your meals. Better yet, if you take it with milk. Tea is also a very good source of antioxidants as will be discussed later.

3. Dairy products

Milk, cheese and yoghurt decrease the iron absorbed into your body. Calcium is also important for osteoporosis, so it is good to include as many dairy products as you can in your diet. Lower fat varieties of milk (skimmed or semi-skimmed) and cheese are just as high in calcium and may be preferred if you are watching your weight. At least one pint of milk should be taken everyday.



Foods that increase non-meat iron absorption

1. Vitamin C

Vitamin C is present in fruit, fruit juice and vegetables. It is better to avoid drinking fruit juice, such as orange juice, with your meal or your toast in the morning. Instead, a cup of tea or coffee is better options as they inhibit iron absorption. Alternatively, have a glass of milk! Beer increases iron absorption so it is better to avoid drinking it with your meal too often but you could always have it on its own with some nuts! Fruit and fruit juice are, however, good sources of antioxidants and should be taken on their own as snacks. Boiled vegetables contain much less vitamin C because the vitamin leaks in the water.

2. Meat, poultry, fish and seafood

Meat, poultry, fish and seafood not only contain a lot of meat iron but they also help to absorb more of the non-meat iron from your food! It would be unwise, however, to omit them from the diet altogether as they

contain other vital nutrients, particularly important for children and adolescents.

3. Pickles, sauerkraut, soy vinegar, alcohol sauce

Sauerkraut, pickled onions, turnips and carrots as well as fermented soy products (e.g., miso and soy sauce) enhance iron absorption. The amount of iron absorbed is even higher when the pickled vegetables are added to bread and rye- containing meals.

In general, a low iron diet would contain cereals (maize, whole-grain flour, beans) and root vegetables with little meat, fish or foods rich in Vitamin C. A moderate iron diet would consist of cereals and root vegetables but would also contain some vitamin C-rich foods and meat. High iron diets contain generous quantities of meat, poultry and fish. They also contain foods with high levels of vitamin C such as citrus fruits and some vegetables. A high iron diet can be reduced to a moderate one by the regular consumption of foods which decrease the amount of iron absorbed by our body, such as dairy products, cereals, beans, coffee and tea.

Antioxidants in Food

Antioxidants are important in any diet because as their name suggests, they prevent oxidative damage in the body. In doing so, they play an important role in the prevention of diseases such as coronary heart disease and cancer.

In Thalassaemia, because of the excess iron in the body, there is a higher risk of oxidative damage. In this article, the author will concentrate on the four main antioxidants: Vitamin E, Vitamin C, Carotenoids and Flavonoids.

1. Vitamin E

Vitamin E is the most important dietary antioxidant. Several studies have found that many patients with Thalassaemia have lower levels of Vitamin E in their blood compared to non-Thalassaemics. This could be either because these patients do not take as much Vitamin E in their diet or because their needs are higher. In many studies, when Vitamin E was given as a supplement Vitamin E levels in the blood improved. However, even if your Doctor or Dietician recommends that you take a supplement, the best way for any vitamin to enter your body is through your food.

Vitamin E is fat-soluble which means that it is present in foods that have a high amount of fat. The best sources of Vitamin E are vegetable oils (olive, sunflower, palm and soy oil). The best one to use is probably olive oil because the type of fat it contains can help to prevent heart disease. In Mediterranean countries where olive oil is used a lot (Greece, Portugal, Spain and Italy) heart disease is lower than in Northern Europe. Remember, however, that the vitamin is destroyed slowly with frying. Therefore, the best way to get the most out of your olive oil is to add it to food towards the end of cooking or even after it is cooked, as a dressing. Olive oil mixed with lemon, for example, can make a delicious dressing for fish, chicken, boiled vegetables and salads. Choose the extra virgin olive oil if you like the intense flavour and you tend to use it as a dressing, or experiment with more refined varieties if you want to use it for cooking, making cakes etc. Ghee also contains Vitamin E but since olive oil has additional health benefits, you may like to try using it in cooking.

Other sources of Vitamin E are dairy products, cereals, nuts, eggs and meat. Dairy products are particularly good to include in the diet not only because they contain Vitamin E, but also because they inhibit iron absorption from our food into our body and also because they contain a lot of calcium which can help to prevent Osteoporosis (weak bones). You can try to use milk in cooking or to have a glass of milk with your meal. Skimmed milk has lower levels of Vitamin E than full-cream milk, although the amount of calcium is the same.

2. Vitamin C

Vitamin C increases the absorption of non-meat iron. Therefore, although Vitamin C is a very powerful antioxidant, the use of many foods containing Vitamin C in combination with foods that are high in non-meat iron should be limited. This is particularly important for those with Thalassaemia Intermedia who are not regularly transfused.

Remember that non-meat iron is widely distributed in the diet, present in eggs, chocolate, cereals, vegetables, fruits, roots (potatoes, parsnips), beans and lentils. In the UK several foods are fortified with iron, such as breakfast cereals, wheat flour and bread, although this may not be the case in other countries.



Vitamin C is mainly found in fruit, fruit juices and vegetables. It might be better to have your piece of fruit or glass of fruit juice on their own, in between meals and not during or immediately after your meal. Health professionals recommend people 5 portions of fruit and vegetables to be consumed daily.

Examples of what is one portion are: a glass of fruit juice, a piece of fruit such as an apple, pear, banana, orange, half a grapefruit, one tomato, a helping of vegetables such as carrots, courgettes, French beans or a small salad. Vitamin C is water-soluble, so if vegetables are boiled it will leak out in the water. Light steaming preserves the vitamin better. Cooked vegetables with olive oil and lemon can make a very tasty snack or a light meal. Vitamin E and Vitamin C work better when they are together, so remember to fuel your vegetables with olive oil!

3. Carotenoids

Common dietary sources of carotenoids are carrots, yellow squash, corn, tomatoes, papaya, oranges and dark-green leafy vegetables. Again, most of these foods are high in Vitamin C and therefore the same caution applies as above. It is worth pointing out that the absorption of carotenoids from the diet is much higher when the food contains fat or oil. So, keep adding that olive oil! Carotenoids can be destroyed at high temperatures so keep the cooking temperature low and the time short if you can.

4. Flavonoids

These are found in tea, red wine, fruit and vegetables. What better excuse to include a glass of red wine with your meal! If it is a more sober occasion, have your meal with a cup of tea! Tea will not only give you lots of antioxidants, but it will also inhibit the absorption of iron from your food, especially if you take it with milk. Try to have several cups of tea daily. Remember that we need about 8 glasses of fluid daily to be well hydrated.

Summary

- Vitamin E is mainly found in vegetable oils such as olive oil and sunflower oil. The best one to use is probably olive oil because it can help to protect

against heart disease. Add it towards the end of cooking, after the food is cooked or on raw vegetables because heating can destroy the vitamin.

- Vitamin C is present in fruit and vegetables. It is best not to consume many of those in combination with foods that are high in non-meat iron if you have Thalassaemia Intermedia and are not being transfused. You could have fruit and vegetables in-between meals. Add olive oil to your vegetables because Vitamin C and Vitamin E work better together.
- Carotenoids are found in carrots, yellow squash, corn, tomatoes, papaya, oranges and dark-green leafy veg-etables. As these foods are also high in Vitamin C, the above caution applies. Again, olive oil.
- Tea and red wine contain flavonoids and are also antioxidants. Furthermore, tea inhibits iron absorption.

This article has been included in the book with the author's permission:

Dr. Dona Hileti-Telfer,
Senior Dietician,
Great Ormond St. Hospital for Sick Children,
London

T2* Measures Iron Content in Heart

T2* is a time measurement that may reflect iron content in tissue. The T2* measurement is obtained from images taken on a standard Magnetic Resonance Image (MRI) machine. The MRI machine uses a strong magnet and radio waves to image body tissues. The MRI machine detects differences in magnetic properties of the body and converts these differences into pictures that physicians can use to diagnose various diseases. Iron overload causes changes in the magnetic properties of tissues, which causes the T2* values to become smaller. The T2* measurement of the heart is important because it has been found that patients with a cardiac T2* value, for example, less than 20 milliseconds (a millisecond is 1/1000 of a second) are at higher risk for heart problems related to iron overload than patients with T2* value, for example, greater than 20 milliseconds.

T2* testing involves a 45 minute scan in a closed MRI machine. The patient will be placed on a padded table and special electrical leads will be placed on their chest to monitor their heart rate. The patient will also wear a headset with a microphone so he/she can communicate with the technician. The table will be slowly moved into the MRI machine, so that the patient's entire body will be inside the tunnel. (The MRI machine is shaped like a large donut with a deep tunnel.) During the MRI scan, the patient must lie very still and listen for directions to hold his/her breath for short durations of time for measurement purposes. The MRI machine will make loud clanking and banging noises while the measurements are being gathered. The headset the patient wears will protect their ears from the loud sounds. The test is completely non-invasive and painless.

Moreover, because the MRI makes images of the beating heart while making the T2* measurement, heart function can also be assessed. Heart function measurements done through MRI are considered more accurate than measurements made from a routine cardiac ultrasound. The MRI can also measure the size and performance of the right ventricle, the chamber of the heart that pumps blood to the lungs. Patients with thalassaemia are at risk of developing pulmonary hypertension (high pressure in the lungs), which can cause enlargement of the right ventricle of the heart. This in turn can decrease its effectiveness in pumping blood.

Implicated scientists are now in the process of confirming all the above information obtained from clinical observations and TIF and NIH of USA are currently supporting these efforts.



Flow Charts

A MANAGEMENT OF PATIENTS WITH THALASSAEMIA MAJOR

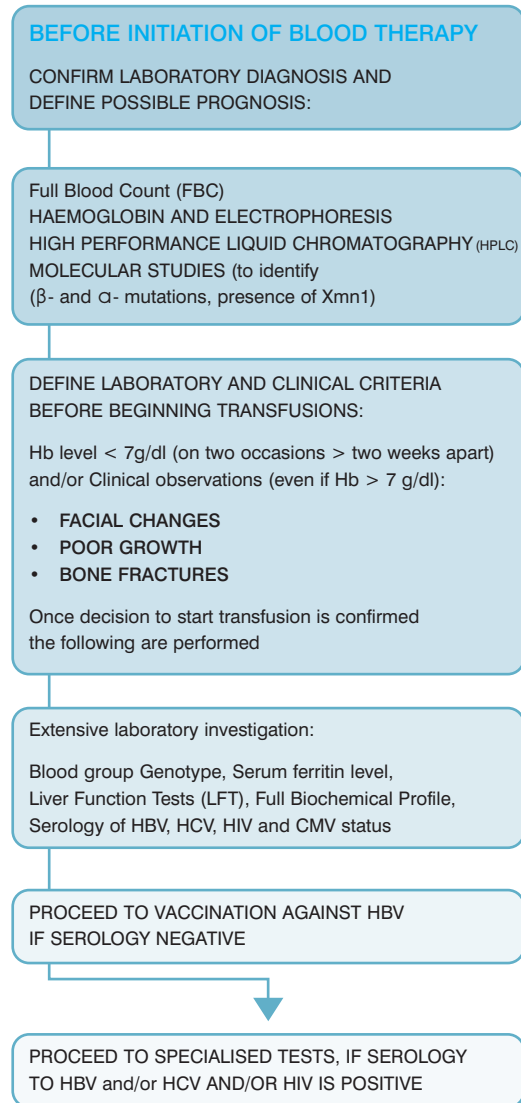

B MANAGEMENT OF PATIENTS WITH β -THALASSAEMIA MAJOR

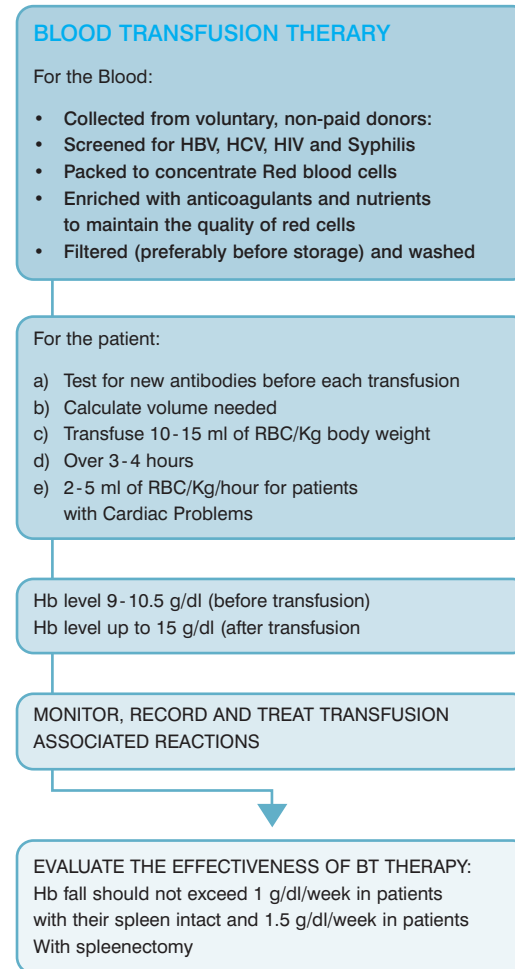

C MANAGEMENT OF PATIENTS WITH β -THALASSAEMIA MAJOR

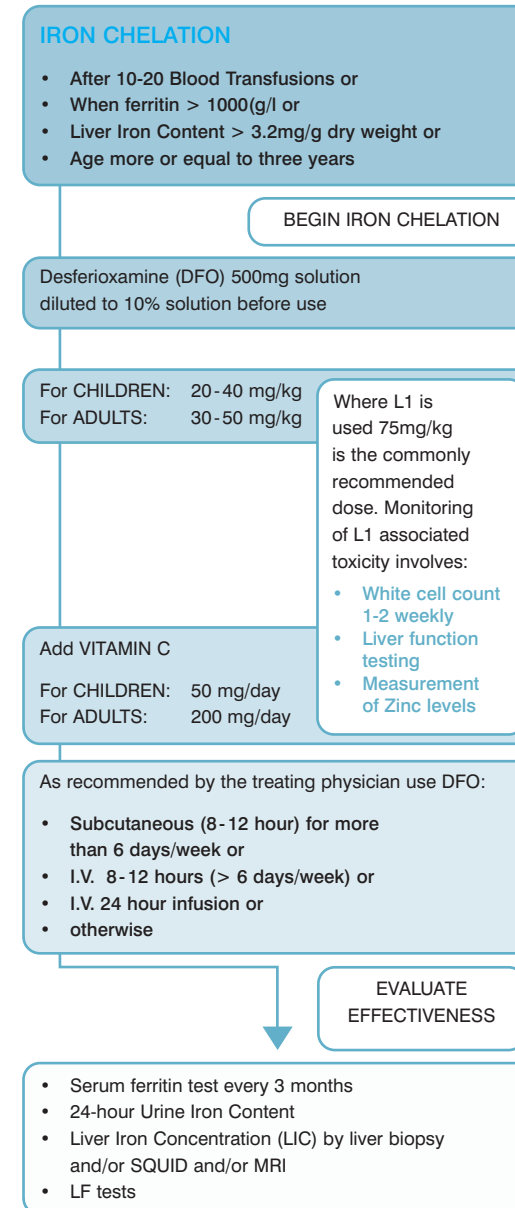

PREGNANCY: When confirmed DFO is stopped

D MONITORING AND ADDRESSING ADVERSE REACTIONS/COMPLICATIONS ASSOCIATED WITH DESFERIOXAMINE

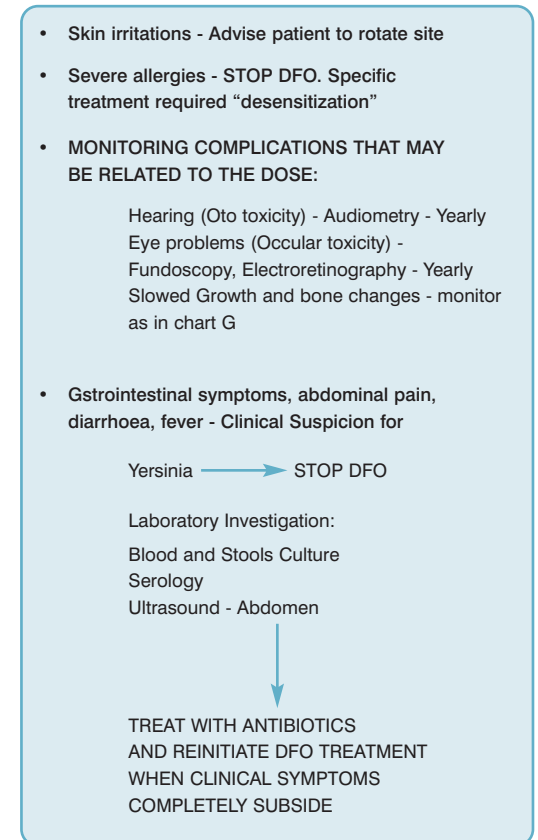

E MANAGEMENT OF PATIENTS WITH HYPERSPLENISM (LARGE SPLEEN)

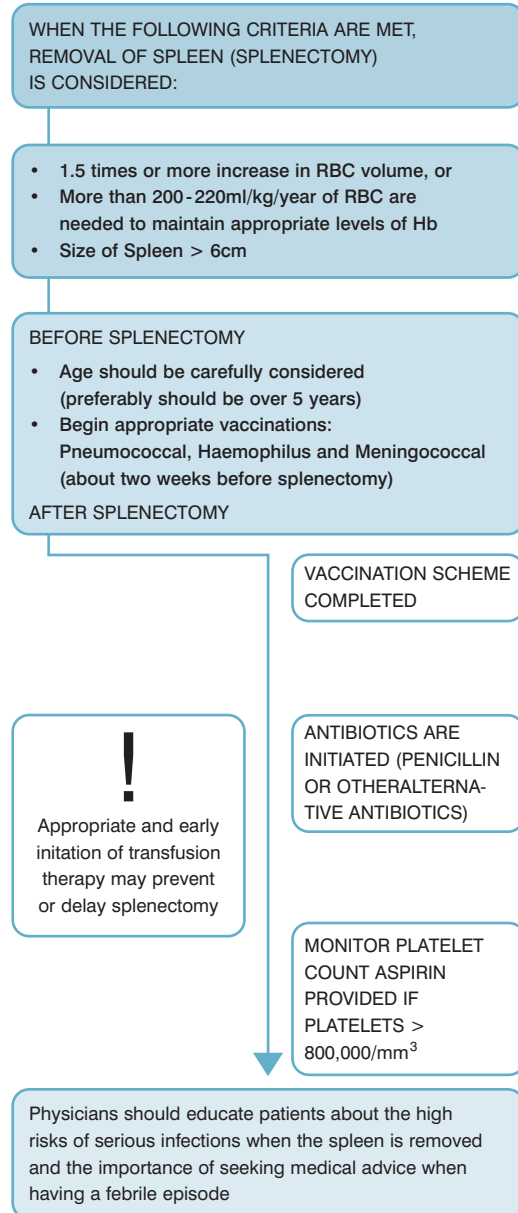

F FULL CARDIOLOGICAL ASSESSMENT YEARLY

More frequently in case of complications or when treating physicians considered necessary:

- Electrocardiogram (ECG) combined with exercise
- 24-hour ECG allowing abnormalities of the heart rhythm to be identified
- Echocardiogram - measuring the size of the chambers and how well each part of heart is functioning (at rest or while patient exercises)
- MUGA is a radioisotopic test that provides additional information on heart function
- Magnetic Resonance Image (MRI) for measurement of heart iron content (under evaluation still)

G MANAGEMENT OF ENDOCRINE AND BONE DISORDERS IN PATIENTS WITH THALASSAEMIA MAJOR

FOR GROWTH:
Measure height (sitting, standing) - Quarterly a year

SEXUAL DEVELOPMENT:

- (i) TANNER 6-MONTHLY FROM 10 YEARS
- (ii) FSH, LH (Hormones) - 6 monthly
- (iii) Oestradiol, testosterone (Hormones) - 6 monthly

DIABETES:

- (i) Measurement of glucose in blood and urine at every visit
- (ii) Glucose Tolerance Test (GTT) - YEARLY

HYPOTHYROIDISM:
T4, TSH 6-MONTHLY

HYPOPARATHYROIDISM:

- (i) Ca, PO4 3-MONTHLY
- (ii) PTH and Vitamin D if Ca is Low

BONE:

- (i) BONE AGE - (X-rays of Knees, wrists) At start of treatment and 1-2 yearly until growth is completed
- (ii) DEXA scan for osteoporosis - yearly after the age of 8 years of age
- (iii) SPINAL X-ray - yearly until growth completed

H MONITORING EFFECTIVENESS OF DFO TREATMENT

Serum Ferritin	< 1000µg/L	Continue and reduce only if therapeutic index is < 0.025
Liver Iron	or 3.2-7mg/g dry weight	
Liver Iron	< 3.2mg/g dry weight	Stopping DFO may be considered and re-evaluation after six months
Serum Ferritin	> 2,000µg/L	Increase dose or frequency
Liver Iron	7-15mg/g dry weight	
Serum Ferritin	Persistently > 2,500µg/L	24-hour i.v. infusions of DFO or 24-hour subcutaneous continuous infusion may be effective in reducing ferritin and LIC
Liver Iron	> 15mg/g dry weight	

* Care is taken not to exceed recommended maximal doses when these are increased
(From Current Strategies and perspectives in Thalassaemia treatment - Dr J Porter)



I MONITOR OF HEPATITIS C VIRUS (HCV) INFECTION

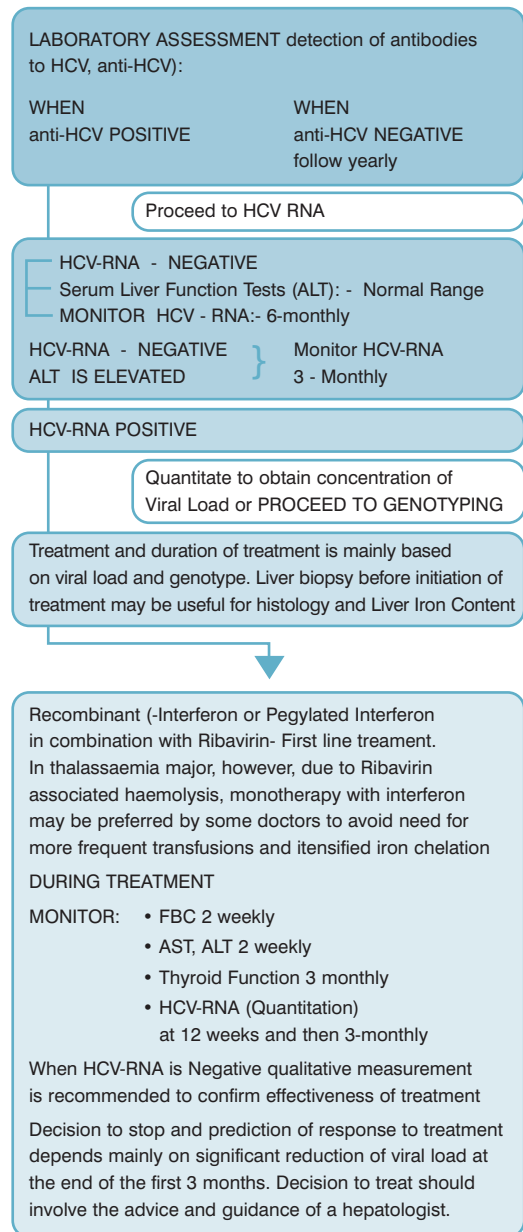

J MONITOR HEPATITIS B VIRUS (HBV) INFECTION

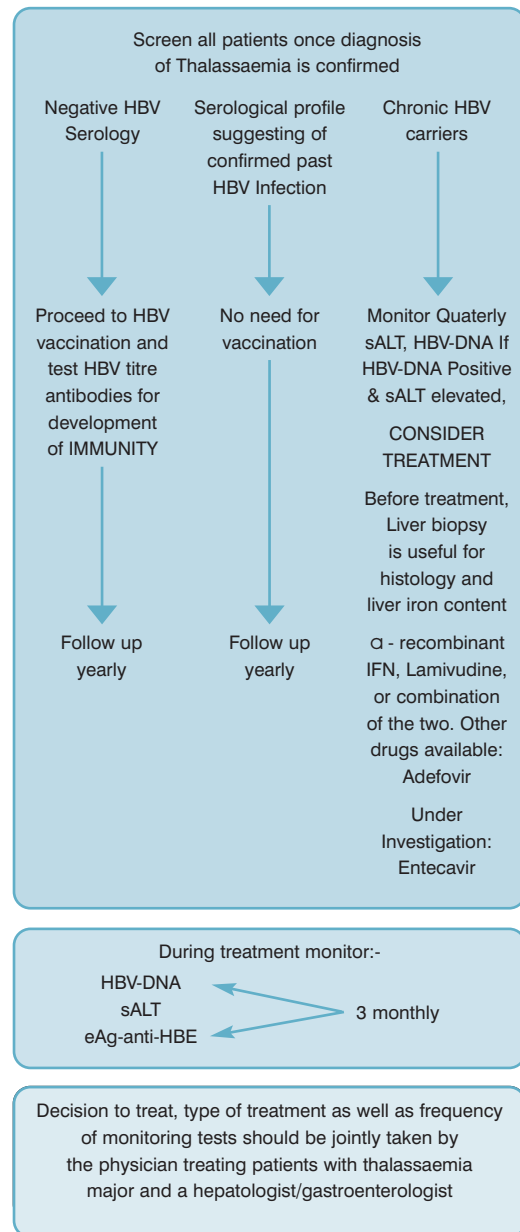

Abbreviations, units and measures used in the book

UNITS USED:

BLOOD VOLUME:	millilitres (ml) 1/1000th of one Litre
HAEMOGLOBIN:	grams per decilitre (g/dl) decilitre = 1/100th of a Litre
WEIGHT:	kilograms (kg)
DOSE OF MOST DRUGS:	milligrams (mg) (DFO, L1) 1/1000th of a gram
FERRITIN:	micrograms ((g/L) 1/10,000th of a gram per litre

COMMON ABBREVIATIONS

B19:	Parvovirus B-19
EBV:	Epstein Ban Virus
DEFERIOXAMINE:	DFO
IRON:	Fe
HEPATITIS B virus:	HBV
HEPATITIS C virus:	HCV
HUMAN IMMUNODEFICIENCY VIRUS:	HIV
SERUM ALANINE AMINOTRANSFERASE:	sALT-Liver Function Test
SERUM ASPARTATE AMINOTRANSFERASE:	sAST-Liver Function Test
HAEMOGLOBIN:	Hb
HAV:	Hepatitis A Virus
RED BLOOD CELLS:	RBC
MRI:	Magnetic Resonance Image

Crosswords - brain teasers

FALLEN PHRASES

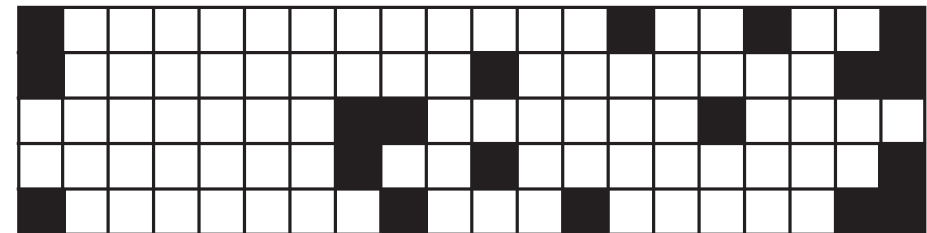

I N R O U I O C E A
 T S E A R S P E H N D T E C
 A H H L A G S E D M G A G I N I S O
 P I H E E S S T A E H I S E E S F E N
 D T R A N T E H T T A S E I L D R R N M

DIRECTIONS

Each letter appears in the same column, but below where it should be. Put the letter back in the grid and rebuild the phrase.

See the solution on page 138.

HIDDEN MESSAGE

T R U M O L E C U L A R S E G E U D L A
 R S R D F I L T R A T I O N R F E B L T
 E I T O O O E M D T S Y R A N F S F U N
 A X I N S I C O A E N Y S G O E R E S A
 T A C A A T T L O N Y I C R O C N U T L
 M L A T R I R P B U N V M T E T R T O U
 E Y R I N C O M P A T I B I L I T Y N G
 N H I O T T P A H E T T T Q V V U A O A
 T P A N A Y H T L Y I C T O Y E A N I O
 H A E M A T O C R I T A L D L N L E T C
 N N E S G I R H I M P A I R M E N T A I
 T A M I H L E I R E G I M E N S O F G T
 H L I S I A S N F E M B O L I S M E U N
 O F N Y T U I G M S I S O N G A I D F A
 H A I L L Q S O L A B O R A T O R Y I A
 S S M A I N T E R N A T I O N A L A R E
 M I U N A Y S N O I S U F S N A R T T P
 A T M A C I A I M E A S S A L A H T N E
 N I B O L G O M E A H N A I N I S R E Y
 S E R O C O N V E R T N E I T A P T C S

ACTIVITY
 ANTICOAGULANT
 DEFORMITY
 EFFECTIVENESS
 FILTRATION
 HAEMOGLOBIN
 INTERNATIONAL
 MATCHING
 PATIENT
 SEROCONVERT
 TREATMENT

ANALYSIS
 CENTRIFUGATION
 DIAGNOSIS
 ELECTROPHORESIS
 HAEMATOCRIT
 IMPAIRMENT
 LABORATORY
 MINIMUM
 QUALITY
 THALASSAEMIA
 URTICARIA

ANAPHYLAXIS
 CYTOMEGALOVIRUS
 DONATION
 EMBOLISM
 HAEMATOPOESIS
 INCOMPATIBILITY
 MANNITOL
 MOLECULAR
 REGIMEN
 TRANSFUSIONS
 YERSINIA

DIRECTIONS

Find the hidden words in any direction (horizontal, vertical, diagonal, forwards, backwards). After all of the words are found, the letters that are not used reveal a hidden message.

See the solution on page 138.

LETTER TILES

CUM AC LAS DY TE BO IN MIA
 RON TO CA SAE USE THE THA SI
 ULA

DIRECTIONS

Unscramble the tiles to reveal a message.

See the solution on page 139.

CROSSWORD ONE

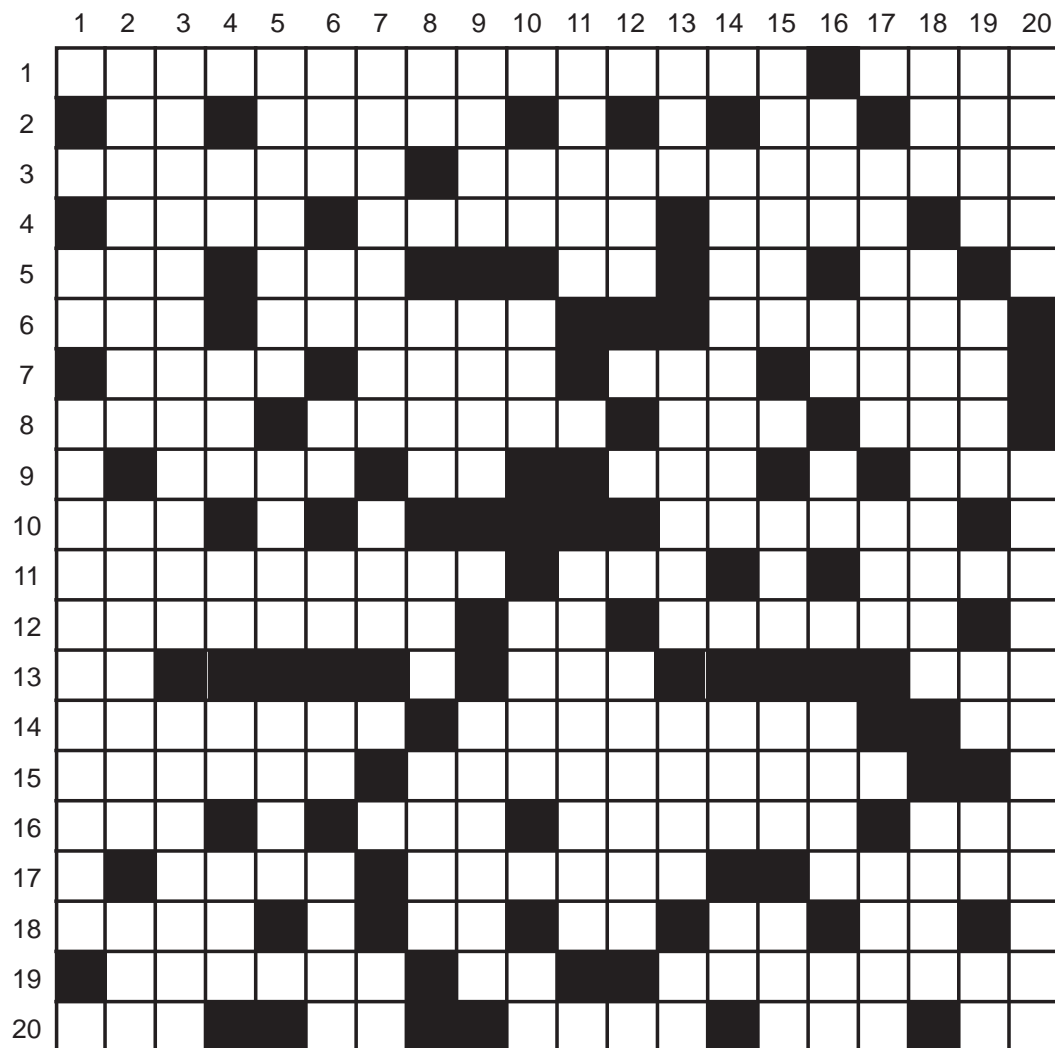

See the solution on page 139.

about thalassaemia

ACROSS

- 1a. Increase in the numbers of white blood cells without cytoplasmic granules
- 1b. One of the senses (verb)
- 2a. Eye without....a centre
- 2b. Product of the kidney
- 2c. A note appended to a letter after the signature (postscript)
- 2d. A playing card
- 3a. A very useful medicine for the heartburn
- 3b. Increase in the number of WBC
- 4a. Of the mouth
- 4b. You can "surf" when you go there
- 4c. A serious disease that weakens the immunity of the patient
- 4d. The most famous lady worldwide
- 5a. In terms of
- 5b. And so on
- 5c. The two ends of ... a key
- 5d. Pneumonic
- 5e. Tennis ... need these
- 6a. Letters found in the word synovium
- 6b. Cannot do
- 6c. Process of getting older
- 7a. Visited very often by Schumacher
- 7b. A burden for the organism undergoing haemodialysis
- 7c. Jean d' ..., a French hero
- 7d. With no clothes on
- 8a. Shell prize
- 8b. The human body burns glucose to produce it
- 8c. Pronoun objective case of "He"
- 8d. French for mine
- 9a. Acid found in urine and increased in patients with gout
- 9b. Similar consonants
- 9c. Volleyball term
- 9d. Found in ... West
- 10a. Bones (Latin, unfinished)
- 10b. A group of physiologically or anatomically related organs
- 11a. Infection of the lungs
- 11b. Acute febrile highly contagious viral disease
- 11c. The first name of the first man on the moon
- 12a. Workplace of a nurse
- 12b. Hello
- 12c. "n" shaped tube running from the liquid in a vessel to a lower level outside the vessel so that liquid runs through the tube
- 13a. Year (Abbreviation)
- 13b. The three letters used to denote blood groups
- 13c. Pele's T-Shirt number
- 14a. Treats mania
- 14b. Protein functioning in the storage of iron
- 14c. More but ... less
- 15a. Man is a member of this kingdom
- 15b. Having the same relative structure, position or value
- 16a. "Expanded gas shock", shock absorbed
- 16b. Bruce..., Martial art athlete and actor
- 16c. The position of something
- 17a. Unspecialised cell that gives rise to differentiated cells
- 17b. Heart chambers (genitive)
- 17c. Formation of frost on a surface
- 18a. Turn around and around (past)
- 18b. Abreviation for Duodenal Uleer
- 18c. Symbol of the chemical element tin.
- 18d. Same as 12b horizontally
- 18e. Musical note
- 19a. Sensory layer of the eye possessing rods and cones
- 19b. Synonym for therefore
- 19c. Brandname for desferrioxamine
- 20a. Angeles, state of U.S.A.
- 20b. Function word to indicate an alternative
- 20c. Chemical element Zn
- 20d.Tze Tung. Chinese hero
- 20e. Very small and....incomplete

DOWN

- 1a. Third singular of "to be"
- 1b. Measures to prevent a disease
- 2a. Genetic constitution of an individual
- 2b. Loud breathing noises while sleeping
- 2c. Advantage
- 3a. A group of RNA viruses (HIV is a member)
- 3b. Aggregate of cells having a similar structure
- 4a. Automobile association
- 4b. Acronym for Taylor
- 4c. Not down
- 4d. Metric unit of length equal to 100 meters
- 4e. Dynamite
- 5a. Cellular organelle possessing DNA
- 5b. Index of Medieval Medical Images
- 5c. Suffix for verbs
- 6a. Upper respiratory injection
- 6b. Postal code for Tennessee
- 6c. E.U ancestor
- 6d. Occupational therapy
- 6e. University of Louisiana
- 6f. Prefix denoting the menstrual period
- 7a. Antiarrhythmic and topical anaesthetic
- 7b. Prefix meaning again
- 7c. The edges ... of air
- 8a. Position of a switch
- 8b. Have young (used of animals, past)
- 8c. Sick
- 8d. The upper part of the body
- 9a. The smallest structural unit of living matter able to function independently
- 9b. "The ..., of the Rings", a hollywood movie
- 9c. A developing human
- 10a. Effectiveness index
- 10b. The first half of ...an engine
- 10c. Deep red iron-containing substance in Hb and Myoglobin
- 10d. A famous wizard
- 11a. The body excluding head, neck and limbs
- 11b. Condition marked by an increase in fibrous tissue
- 12a. Lock's best friend
- 12b. New..., a state of USA (missing the last letter)
- 13a. Found on the store-button of the calculator
- 13b. Incompatibility of these blood group between mother and foetus causes hydrops foetalis and erythroblastosis
- 13c. Electrically charged atoms
- 13d. Electric current that flows in one direction steadily
- 14a. The maximum production possible
- 14b. Fridays (American Restaurant)
- 14c. A pronoun
- 15a. Secretely collecting classified information
- 15b. A small drink
- 15c. Numerical
- 15d. Information system Medical
- 16a. Sexually Transmitted Disease
- 16b. A consonant
- 16c. Extraterrestrial
- 16d. Osman....Pasha, Turkish general
- 16e. The fourth note of the diatonic scale
- 17a. Mouthlike opening in a bodily organ (latin)
- 17b. English National Opera
- 17c. Male or Female given name
- 18a. Emergency alert system
- 18b. Natural qualities or talents
- 18c. A person who doesn't say the truth
- 19a. Reacting with a base produces salt
- 19b. Functional unit of DNA that controls the expression of traits
- 19c. Slang for "them"
- 19d. inside
- 19e. adjective
- 20a. Sit again
- 20b. abnormal enlargement of the spleen

CROSSWORD TWO

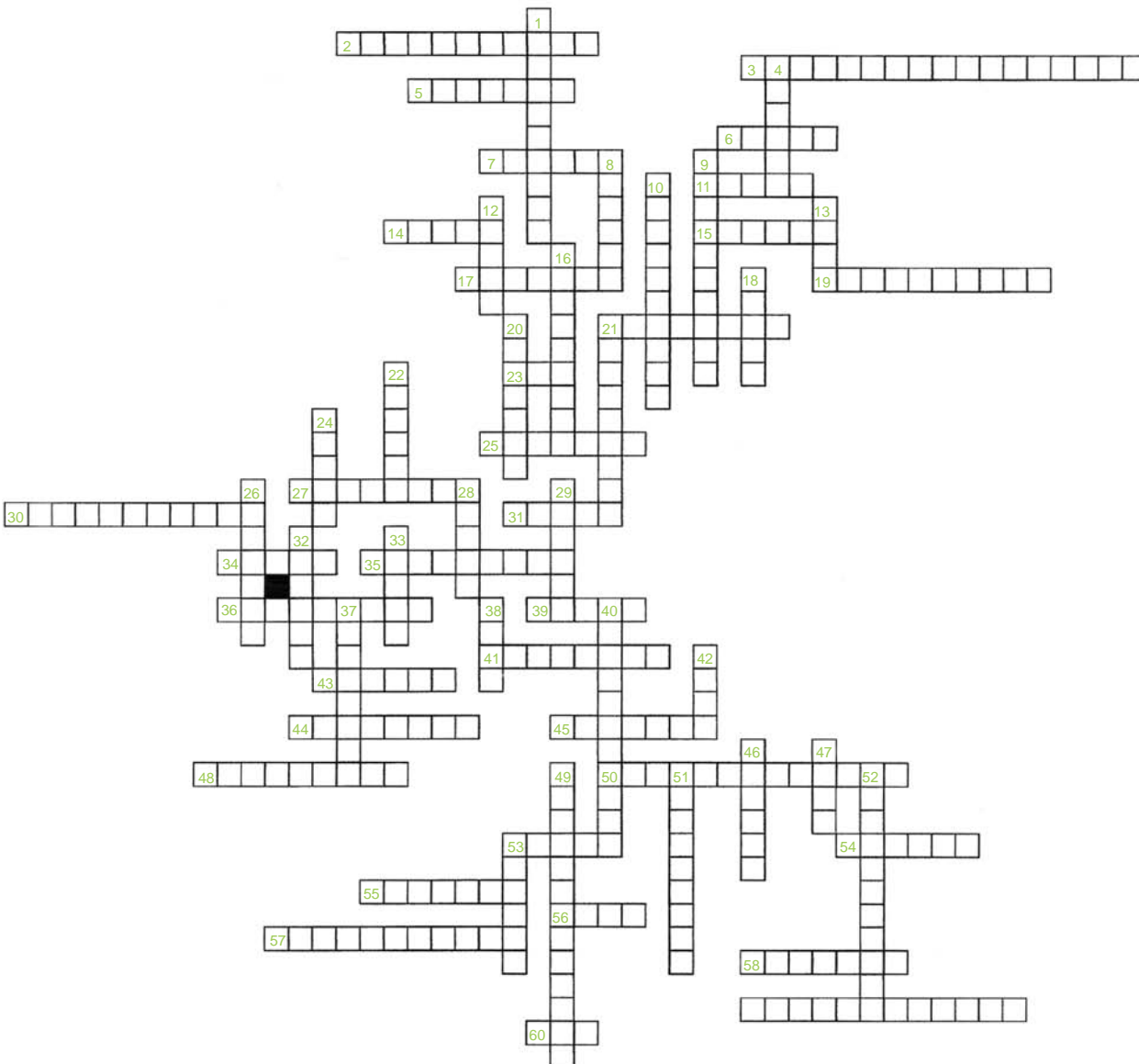

ACROSS

2. the cardiovascular system
3. polymorphonuclear
5. HIV is one (plural)
6. group of tissues working together
7. substance found in blood and used to diagnose certain disease
11. the product of the nephron
14. encloses the brain
15. the body defence system
17. ...anaemia, thalassaemia major
19. attacked by HIV
21. they are made of aminoacids
23. abbreviation for erythrocyte
25. "No blood" in medical terms
27. staphylococcus is one, here many
30. platelett
31. the main organs of human pulmonary system
34. the blood pump
35. the smallest vessell
36. takes place mainly in stomach
39. DNA functional units
41. monocyte
43. cell-free blood
44. mulfunction , disease
45. not local, not belonging here
48. surrounds the nucleus
50. glucose belongs to their category
53. made up of vertebrae
54. produces urine
55. harbours the DNA
56. long, thin bones that form the thorax
57. granulocyte
58. the main blood protein
59. in homazygous form is called cooley's
60. any fluid turns in that after extensive heating

DOWN

1. produces blood cells (2 words)
4. vital for human life
8. one type of blood grouping
9. supply of food
10. a clotting protein
12. the largest tissue in human body
13. the smallest unit of human body
16. white blood cell
18. thrush is caused by these
20. thyroxine is one
21. their survival harms other organisms
22. group of cells cooperating
24. scientific term for the species of man
26. DNA is this kind of material
28. one becomes after adolescence
29. fascilitates body reactions
32. efferent vessel
33. large, main
37. hellenic for sea
38. heart aets like one
40. red blood cell
42. afferent vessel
46. the headquarters of TIF are on this island
47. triglycerides belongs to this category
49. ...anaemia, thalassaemia
51. white cells staining purplish
52. white cells staining reddish
53. group of organs

See the solution on page 140.

SOLUTIONS

- ACTIVITY (12, 10, N)
- ANALYSIS (4, 18, N)
- ANAPHYLAXIS (2, 12, N)
- ANTICOAGULANT (20, 14, N)
- CENTRIFUGATION (19, 20, N)
- CYTOMEGALOVIRUS (5, 18, NE)
- DEFORMITY (18, 1, SW)
- DIAGNOSIS (18, 14, W)
- DONATION (4, 2, S)
- EFFECTIVENESS (16, 1, S)
- ELECTROPHORESIS (7, 1, S)
- EMBOLISM (10, 13, E)
- FILTRATION (5, 2, E)
- HAEMATOCRIT (1, 10, E)
- HAEMATOPPOESIS (1, 13, NE)
- HAEMOGLOBIN (11, 19, W)
- IMPAIRMENT (9, 11, E)
- INCOMPATIBILITY (4, 7, E)
- INTERNATIONAL (5, 16, E)
- LABORATORY (9, 15, E)
- MANNITOL (8, 3, SE)
- MATCHING (8, 7, S)
- MINIMUM (3, 12, S)
- MOLECULAR (4, 1, E)
- PATIENT (17, 20, W)
- QUALITY (6, 15, N)
- REGIMEN (9, 12, E)
- SEROCOVERT (1, 20, E)
- THALASSAEMIA (18, 18, W)
- TRANSFUSIONS (18, 17, W)
- TREATMENT (1, 1, S)
- URTICARIA (3, 1, S)
- YERSINIA (20, 19, W)

Regular blood transfusions greatly contribute to the quality and length of life of thalassaemia patients.

HIDDEN MESSAGE

Thalassaemia is an inherited genetic disease passed from parent to children through the genes.

FALLEN PHRASES

CROSSWORD ONE

Thalassaemia causes iron to accumulate in the body

LETTER TILES

1	A	G	R	A	N	U	L	O	C	Y	T	O	S	I	S	H	E	A	R	
2	A	E	E	U	R	I	N	E	R	T	P	S	A	C	E					
3	A	N	T	A	C	I	D	L	E	U	K	O	C	Y	T	O	S	I	S	
4	O	R	A	L	O	N	L	I	N	E	A	I	D	S	D	I				
5	I	T	O	E	T	C	K	Y	P	N	S	E	T							
6	S	Y	V	U	N	A	B	L	E	A	G	E	I	N	G					
7	P	I	T	S	I	R	O	N	A	R	C	N	U	D	E					
8	P	E	R	L	E	N	E	R	G	Y	H	I	M	M	O	N				
9	R	U	R	I	C	D	D	N	E	T	E	T	E	W	E	S				
10	S	S	S	M	A	S	Y	S	T	E	M	P								
11	P	N	E	U	M	O	N	I	A	F	L	U	I	N	E	A	L			
12	H	O	S	P	I	T	A	L	H	I	S	I	P	H	O	N	E			
13	Y	R							L	A	B	O								
14	L	I	T	H	I	U	M	F	E	R	R	I	T	I	N	M				
15	A	N	I	M	A	L	H	O	M	O	L	O	G	O	U	S				
16	X	G	S	T	L	E	E	S	E	N	I	O	R	L	I	E				
17	I	S	T	E	M	A	T	R	I	A	S									
18	S	P	U	N	E	D	U	S	N	S	H	I	L	A	V	A				
19	R	E	T	I	N	A	S	O												
20	L	O	S																	



Useful Websites:

- <http://www.thalassaemia.org.cy>
Includes the following:

1. Scientific Advisors
2. Scientific Collaborators
3. National Thalassaemia Associations
4. Educational Material
5. Coming Events

Travel information:

International Travel and Health 2002 Prepared by WHO

- <http://www.who.int/ith>
- email: cdsdoc@who.int

WHO: World Health Organization

WHO Geneva headquarters

- <http://www.who.ch>

WHO Africa Regional Office

- www.whoafr.org

WHO Europe Regional Office

- www.who.dk

WHO Southeast Asia Regional Office

- www.paho.org

WHO Eastern Mediterranean Regional Office

- www.who.sci.eg

WHO Western Pacific Regional Office

- www.who.org.ph

HIV and Hepatitis

- www.hivandhepatitis.com

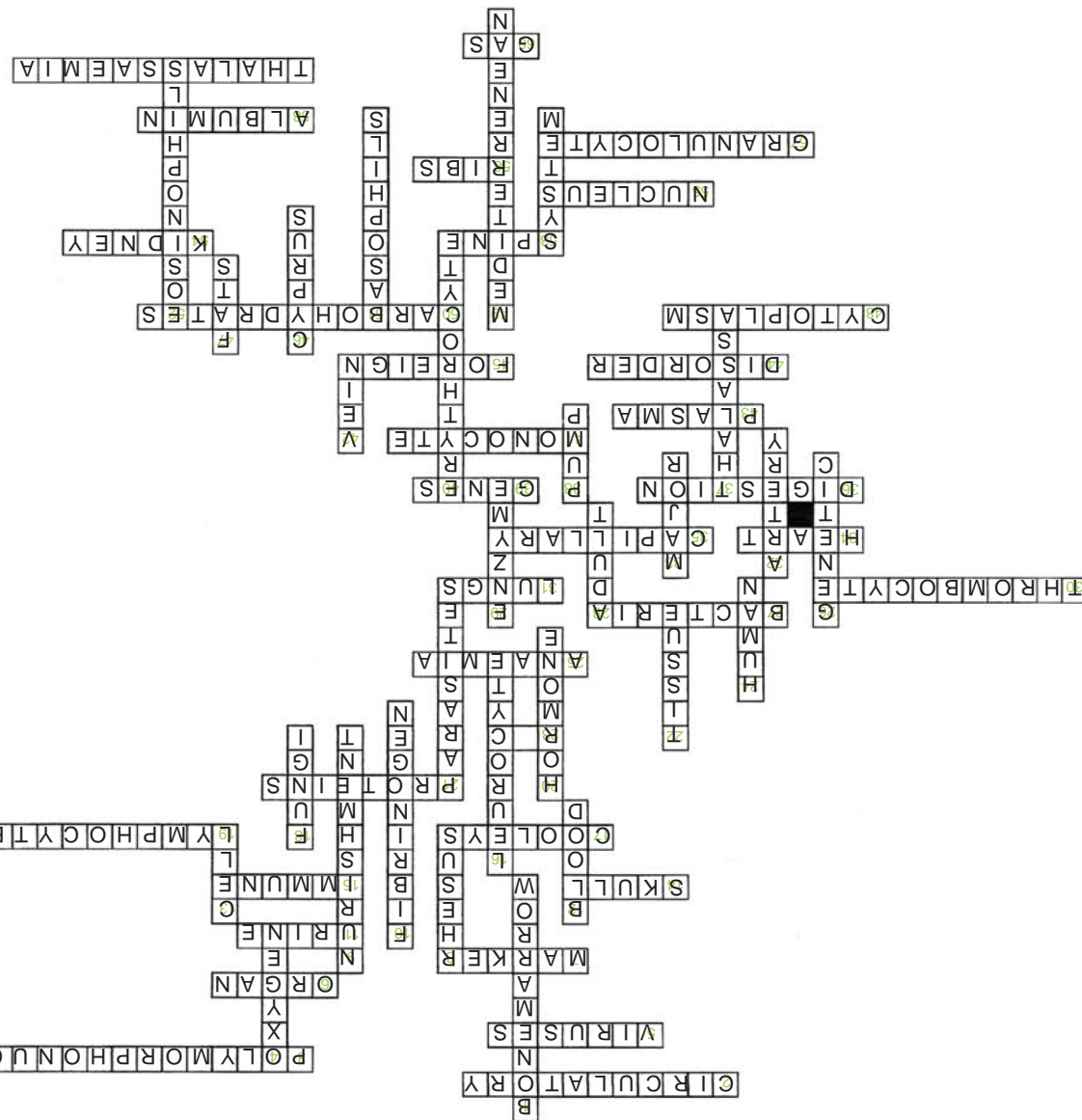

CROSSWORD TWO

HIV

- www.who.int/hiv_aids/first.html

ICBS: International Consortium of Blood Safety

- www.icbs.com/about/htm

ISBT: International Society for Blood Transfusion

- isbt@eurocongress.com

Blood Safety

- www.int/health_topics/blood_safety/en

Interactive Groups for Discussions

- <http://groups.msn.com/thalassemiapatientandfriends/home.htm>

Product Information prepared by WHO

- www.inf/vaccines_documents/

Useful Correspondence and Information:

WHO Headquarters

World Health Organization Headquarters
Avenue Appia 20, 1211 Geneva 27, Switzerland

Telephone: (41 22) 791-21-11 / Fax: (41 22) 791-0746

Cable: UNISANTE GENEVA / Telex: 415 416

Email: info@who.int / Website: <http://www.who.ch/>

AFRICA

WHO Regional Office

Dr. Naomi Nhiwathiva, Chief DCP, Regional Office for Africa, World Health Organization, Parirenyatwa Hospital, P.O. Box BE 773, Harare, Zimbabwe

Telephone: (263) 407-69-51 or (263) 470-74-93

Fax: (263) 479-01-46 or (263) 479-12-14

Telex: 5217 or 5364 UNISANTE Cable: UNISANTE BRAZZAVILLE

Email: regafro@whoafr.org

Website: <http://www.whoafr.org/>

EUROPE

WHO Regional Office

J.E. Asvall, Regional Director, Regional Office for Europe Accident Prevention Programme, World Health Organization, 8, Scherfigsvej, DK-2100 Copenhagen 0, Denmark

Telephone: (45) 39-17-17-17 / Fax: (45) 39-17-18-18

Telex: 15348 or 15390 / Cable: UNISANTE COPENHAGEN

Email: postmaster@who.dk

Website: <http://www.who.dk/>

AMERICAS

WHO Regional Office

George A.O. Alleyne, Regional Director, Regional Office for the Americas, Emergency Preparedness & Disaster Relief Coordination, World Health Organization, Pan American Sanitary Bureau, 525 23rd Street NW, Washington, DC 20037, USA

Telephone: (202) 974-3000 / Fax: (202) 974-3663

Telex: 248338-440057-64152-892744

Cable: OFSANPAN WASHINGTON

Email: postmaster@paho.org / Website: <http://www.paho.org/>

SOUTHEAST ASIA

WHO Regional Office

Mrs Harsaran Bir Kaur Pandey, IO Regional Office for South East Asia World Health Organization, World Health House Indraprastha Estate, Mahatma Gandhi Rd, New Delhi, 110002 India

Telephone: (91) 11-331-7804 or (91) 11-331-7823

Fax: (91) 11-331-8607 or (91) 11-332-7972

Telex: 3165095 or 3165031 / Cable: WHO NEW DELHI

Email: postmaster@whosea.org

Website: <http://tron.um.u-tokyo.ac.jp/>

EASTERN MEDITERRANEAN

WHO Regional Office

Hussein A.Gezairy, M.D., F.R.C.S., Regional Director Regional Office for the Eastern Mediterranean World Health Organization, PO Box 1517, Alexandria, 21511 Egypt

Telephone: (203) 48-202-23 or (203) 48-202-24 or (203) 48-300-90

Fax: (203) 48-389-16 or (203) 48-243-29

Telex: 54028 or 54684 / Cable: UNISANTE ALEXANDRIA

Email: emro@who.sci.eg / Website: <http://www.who.sci.eg>

WESTERN PACIFIC

WHO Regional Office

Dr. Shigeru Omi, Regional Director, Regional Office for the Western Pacific Health Services, Development & Planning World Health Organization PO Box 2932, 1099 Manila, Philippines

Telephone: (632) 528-80-01 / Fax: (632) 521-10-36 or (603) 536-02-79

Telex: 27652-63260-40365 / Cable: UNISANTE MANILA

Email: postmaster@who.org.ph

Website: <http://www.who.org.ph/>

Council of Europe (CoE)

Mr Karl Friedrich Bopp

Administrative Officer, Health & Social Affairs Directorate General III Social Cohesion 67075 Strasbourg, France

Tel: 33388412214 / Fax: 33388412726

Email: Karl-friedrich.bop@coe.int

European Commission

Dr Lieve Franssen, Principal Administrator, Health and Family Planning, AIDS Unit, Rue de Geneve/Genevestraat 12, B1140, Bruxelles

Tel: +32-2 2963698/2969117

Fax: 2963697

Food and Drug Administration (FDA), USA

Dr Jay Epstein, Director, Office of Blood Research and Review, Center for Biologics Evaluation and Research, Food and Drug Administration, HFM-300, 1401 Rockville Pike, Rockville, MD 20852

Tel: + 13018273518 / Fax: + 13018273533

Email: epsteinj@cber.fda.gov

International Consortium for Blood Safety (ICBS)

Dr Mohamed El-Nageh, Executive Director, New York
Blood center, 310E 67th Street, New York, NY 10021, USA

Tel: +12125703319 / Fax: +12125703320

Email: elnagehmm@aol.com

International Federation of Blood Donor Organizations (FIODS)

Mr Niels Mikkelsen, Secretary General, Bloddonorerne
Denmark, Vesterbrogade 191, 1800 Frederiksberg, Denmark

Tel: + 4570137014 / Fax: + 4570127010

Email: mikkelsen@bloddonor.dk

International Federation of Red Cross and Red Crescent Societies (IFRCRC)

Mr Peter Carolan, Senior Officer,
Case Postale 372, 1211 Geneva 19, Switzerland

Tel: + 41227304222

Fax: + 41227330395

Email: carolan@ifrc.org

International Society of Blood Transfusion (ISBT)

Dr Paul Strengers, Secretary General,
PO Box 9190, NL 1006 AD Amsterdam,
The Netherlands

Tel: 31205123212 / Fax: 31205123560

Email: p_strengers@clb.nl

Reference for Chapter 4: Iron Chelation

- 1a. Victor A Hoffbrand and Beatrix Wonke "Long-term Deferiprone Chelation therapy" in Iron Chelation therapy Advances in experimental medicine and Biology" Vol 509 pages 127-139.
- 1b. Lisa J Anderson, Beatrix Wonke, Emma prescot, Sally Holdan, J. Malcolm Walker, Dudley J. Pennell "Comparison pf effects of oral deferiprone and subcutaneous desferrioxamine on myocardia iron concentrations and ventricular function in beta thalassaemia" The Lancet vol 360. August 17, 2002.
2. Grady Rw, Berdoukas Va, Giardina Pj, "Iron Chelators: combined therapy could be a better approach Blood 1998; suppl. 1. P + 2:16b
3. Cohen AR, Galanello R, Piga A, Di Palma A, Vullo C, Tricta F, Safety profile of the iron chelator Deferiprone: a multicentre study." Br. J. Haematol 2000; 108, 305-312.
4. Olivieri NF, Brittenham GM, Mc Laren CE, Templeton DM, Cameron RG KA, "Long-term safety and effectiveness of iron chelation therapy with Deferiprone in thalassaemia major". N Engl J Med 1998: 339, 417 - 423.
5. Ian R. Wanless, George Sweeney, Amar P. Dhillon, Maria Guido, Antonio Piga, Renzo Galanello, M. Rita Gamberini, Elias Schwarz and Alan R. Cohen: Lack of progressive hepatic fibrosis during long-term therapy with Deferiprone in subjects with transfusion-dependent beta-thalassaemia. Blood September 2002. Volume 100, number 5 pages 1566 - 1569.
6. A.V. Hoffbrand, A. Cohen, C. Hersko Role of Deferiprone in Chelation Therapy for transfusional iron overload" Blood March 13, 2003
7. Review John B Porter "Practical Management of Iron Chelation" British Journal of Haematology 2001, 115, 239-252
8. Lancet 2003; 361:1597 - 1602

Acknowledgments

Every effort has been made to acknowledge the source of all illustrations used in this book but also to acknowledge the contribution of all those individuals who have helped with this book and have provided pictures, tables and figures. If an omission does come to light, Thalassaemia International Federation and the author will be pleased to insert the appropriate acknowledgment in any subsequent editions of this book.