

Brewing Science and practice

**Dennis E. Briggs, Chris A. Boulton, Peter A. Brookes and
Roger Stevens**



**CRC Press
Boca Raton Boston New York Washington, DC**

WOODHEAD PUBLISHING LIMITED

Cambridge England

Published by Woodhead Publishing Limited, Abington Hall, Abington
Cambridge CB1 6AH, England
www.woodhead-publishing.com

Published in North America by CRC Press LLC, 2000 Corporate Blvd, NW
Boca Raton FL 33431, USA

First published 2004, Woodhead Publishing Limited and CRC Press LLC

© 2004, Dennis E. Briggs, Chris A. Boulton, Peter A. Brookes and Roger Stevens
The authors have asserted their moral rights.

This book contains information obtained from authentic and highly regarded sources. Reprinted material is quoted with permission, and sources are indicated. Reasonable efforts have been made to publish reliable data and information, but the authors and the publishers cannot assume responsibility for the validity of all materials. Neither the authors nor the publishers, nor anyone else associated with this publication, shall be liable for any loss, damage or liability directly or indirectly caused or alleged to be caused by this book.

Neither this book nor any part may be reproduced or transmitted in any form or by any means, electronic or mechanical, including photocopying, microfilming, and recording, or by any information storage or retrieval system, without prior permission in writing from the publishers.

The consent of Woodhead Publishing Limited and CRC Press LLC does not extend to copying for general distribution, for promotion, for creating new works, or for resale. Specific permission must be obtained in writing from Woodhead Publishing Limited or CRC Press LLC for such copying.

Trademark notice: Product or corporate names may be trademarks or registered trademarks, and are used only for identification and explanation, without intent to infringe.

British Library Cataloguing in Publication Data

A catalogue record for this book is available from the British Library.

Library of Congress Cataloging-in-Publication Data

A catalog record for this book is available from the Library of Congress.

Woodhead Publishing Limited ISBN 1 85573 490 7 (book) 1 85573 906 2 (e-book)

CRC Press ISBN 0-8493-2547-1

CRC Press order number: WP2547

The publisher's policy is to use permanent paper from mills that operate a sustainable forestry policy, and which have been manufactured from pulp which is processed using acid-free and elementary chlorine-free practices. Furthermore, the publisher ensures that the text paper and cover board used have met acceptable environmental accreditation standards.

Project managed by Macfarlane Production Services, Markyate, St Albans, Hertfordshire
(e-mail: macfarl@aol.com)

Typeset by MHL Typesetting Ltd, Coventry, Warwickshire

Printed by TJ International, Cornwall, England

Preface

The two volumes of the second edition of *Malting and Brewing Science I, Malt and Sweet Wort and II, Hopped Wort and Beer*, by James S. Hough, Dennis E. Briggs, Roger Stevens and Tom W. Young, appeared in 1981 and 1982. This book provided the framework for the M.Sc. in Malting and Brewing Science, the course that was offered by the British School of Malting and Brewing in the University of Birmingham (UK). It also provided the backbone of many other courses. After more than 20 years the demand for these volumes has continued, although they are increasingly out of date. *Malts and Malting*, by Dennis E. Briggs, appeared in 1998, and *Brewing Yeast and Fermentation*, by Chris Boulton and David Quain, became available in 2001. These books cover their named topics in depth. However, the need for an up-to-date, integrated textbook on brewing, comparable in scope and depth of coverage to *Malting and Brewing Science*, remained.

Brewing: Science and practice is intended to meet this need. Deciding on the details of the coverage has given rise to some anxious discussions. Practically it is impossible to describe all aspects of all the varieties of brewing processes in depth, in one moderately sized volume. Inevitably it has been necessary to assume some background knowledge of physics, chemistry, biology, and engineering. However, the book is understandable to people without detailed knowledge in these areas. The references at the end of each chapter provide guidance for further reading. Since the wide range of kinds of brewing operations, from simple, low-volume, single-line breweries to extremely large, highly complex, multiple-line installations, does not allow a single description of brewing activities, the book concentrates on the principles of the various brewing processes.

Brewing is carried out all over the world and, unsurprisingly, different terminologies and methods of measurement and analysis are used. The different systems of units and analyses are explained in the text and conversion factors (where valid) and some other useful data are given in the Appendix. A list of abbreviations is included in the index for reference. The index also includes a list of formulae

First of all the authors warmly thank our wives, Rosemary, Wendy, Stella and Betty, for their unfailing patience and good-humoured support. We have also been given a great deal of help from our colleagues and friends. We are grateful to Mrs Doreen Hough for

permission to use some of the late Professor Jim Hough's diagrams. Permission to use other diagrams is acknowledged in the text. We would like to thank: Mrs Marjorie Anderson, Dr John M. H. Andrews, Mrs Marjorie Anderson, Dr Raymond G. Anderson, Mr David J. Banfield, Mr Zane C. Barnes, Herr Volker Borngaber, Mr Andy Carter, Dr Peter Darby, Mr J. Brian Eaton, Dr David L. Griggs, Dr Paul K. Hegarty, Mrs Sue M. Henderson, Mr James Johnstone, Mr Roy F. Lindsay, Dr G. C. Linsley-Noakes, Dr David E. Long, Mr John MacDonald, Dr Ray Marriott, Mr P. A. (Tom) Martin, Dr A. Peter Maule, Ms Elaine McCrimmon, Dr Philip Morrall, Dr Ray Neve, Dr George Philliskirk, Dr David E. Quain, Mr Trevor R. Roberts, Mr Derek Wareham and Dr Richard D. J. Webster. We also wish to thank Coors Brewers for the use of the Technical Centre, Burton-on-Trent.

We apologise if any acknowledgements have been omitted.

Contents

<i>Preface</i>	xvii
1. An Outline of Brewing	1
1.1 Introduction	1
1.2 Malts	1
1.3 Mash Tun Adjuncts	2
1.4 Brewing Liquor	2
1.5 Milling and Mashing in	2
1.6 Mashing and Wort Separation Systems	3
1.7 The Hop-Boil and Copper Adjuncts	4
1.8 Wort Clarification, Cooling and Aeration	4
1.9 Fermentation	5
1.10 The Processing of Beer	5
1.11 Types of Beer	6
1.12 Analytical Systems	7
1.13 The Economics of Brewing	8
1.14 Excise	9
1.15 References and Further Reading	9
1.15.1 The Systems of Malting and Brewing Analysis	9
1.15.2 General	9
2. Malts, Adjuncts and Supplementary Enzymes	11
2.1 Grist and Other Sources of Extract	11
2.2 Malting	11
2.2.1 Malting in Outline	11
2.2.2 Changes Occurring in Malting Grain	14
2.2.3 Malting Technology	19
2.2.4 Malt Analyses	21

2.2.5	Types of Kilned Malt	26
2.2.6	Special Malts	31
2.2.7	Malt Specifications	32
2.3	Adjuncts	34
2.3.1	Mash Tun Adjuncts	34
2.3.2	Copper Adjuncts	40
2.4	Priming Sugars, Caramels, Malt Colourants and <i>Farbebier</i>	45
2.5	Supplementary Enzymes	46
2.6	References	50
3.	Water, Effluents and Wastes	52
3.1	Introduction	52
3.2	Sources of Water	53
3.3	Preliminary Water Treatments	57
3.4	Secondary Water Treatments	60
3.5	Grades of Water Used in Breweries	64
3.6	The Effects of Ions on the Brewing Process	65
3.7	Brewery Effluents, Wastes and by-Products	68
3.7.1	The Characterization of Waste Water	69
3.7.2	The Characteristics of Some Brewery Wastes and by-Products	71
3.8	The Disposal of Brewery Effluents	73
3.8.1	Preliminary Treatments	73
3.8.2	Aerobic Treatments of Brewery Effluents	75
3.8.3	Sludge Treatments and Disposal	78
3.8.4	Anaerobic and Mixed Treatments of Brewery Effluents	79
3.9	Other Water Treatments	82
3.10	References	82
4.	The Science of Mashing	85
4.1	Introduction	85
4.2	Mashing Schedules	88

4.3	Altering Mashing Conditions	95
4.3.1	The Grist	95
4.3.2	Malts in Mashing	97
4.3.3	Mashing with Adjuncts	101
4.3.4	The Influence of Mashing Temperatures and Times on Wort Quality	104
4.3.5	Non-Malt Enzymes in Mashing	110
4.3.6	Mashing Liquor and Mash pH	113
4.3.7	Mash Thickness, Extract Yield and Wort Quality ..	116
4.3.8	Wort Separation and Sparging	119
4.4	Mashing Biochemistry	122
4.4.1	Wort Carbohydrates	122
4.4.2	Starch Degradation in Mashing	127
4.4.3	Non-Starch Polysaccharides in Mashing	136
4.4.4	Proteins, Peptides and Amino Acids	142
4.4.5	Nucleic Acids and Related Substances	146
4.4.6	Miscellaneous Substances Containing Nitrogen ...	146
4.4.7	Vitamins and Yeast Growth Factors	149
4.4.8	Lipids in Mashing	151
4.4.9	Phenols	157
4.4.10	Miscellaneous Acids	161
4.4.11	Inorganic Ions in Sweet Wort	163
4.5	Mashing and Beer Flavour	164
4.6	Spent Grains	166
4.7	References	167
5.	The Preparation of Grists	171
5.1	Intake, Handling and Storage of Raw Materials	171
5.2	The Principles of Milling	175
5.3	Laboratory Mills	178
5.4	Dry Roller Milling	179
5.5	Impact Mills	182
5.6	Conditioned Dry Milling	184

5.7	Spray Steep Roller Milling	184
5.8	Steep Conditioning	186
5.9	Milling under Water	187
5.10	Grist Cases	187
5.11	References	188
6.	Mashing Technology	189
6.1	Introduction	189
6.2	Mashing in	190
6.3	The Mash Tun	194
6.3.1	Construction	194
6.3.2	Mash Tun Operations	198
6.4	Mashing Vessels for Decoction, Double Mashing and Temperature-Programmed Infusion Mashing Systems	199
6.4.1	Decoction and Double Mashing	199
6.4.2	Temperature-Programmed Infusion Mashing	201
6.5	Lauter Tuns	203
6.6	The Strainmaster	211
6.7	Mash Filters	212
6.8	The Choice of Mashing and Wort Separation Systems	217
6.9	Other Methods of Wort Separation and Mashing	220
6.10	Spent Grains	222
6.11	Theory of Wort Separation	222
6.12	References	225
7.	Hops	227
7.1	Introduction	227
7.2	Botany	228
7.3	Cultivation	230
7.4	Drying	234
7.5	Hop Products	236
7.5.1	Hop Pellets	236

7.5.2	Hop Extracts	238
7.5.3	Hop Oils	239
7.6	Pests and Diseases	240
7.6.1	Damson-Hop Aphid (<i>Phorodon Humuli</i> Schrank)	240
7.6.2	(Red) Spider Mite (<i>Tetranychus Urticae</i> Koch)	243
7.6.3	Other Pests	244
7.6.4	Downy Mildew (<i>Pseudoperonospora Humuli</i> (Miyabe and Tak.) G. W. Wilson)	244
7.6.5	Powdery Mildew (<i>Sphaerotheca Macularis</i> (DC.) Burr)	245
7.6.6	Verticillium Wilt (<i>Verticillium Albo-Atrum</i> Reinke and Berth)	246
7.6.7	Virus Diseases	247
7.7	Hop Varieties	248
7.8	References	254
8.	The Chemistry of Hop Constituents	255
8.1	Introduction	255
8.2	Hop Resins	256
8.2.1	Introduction	256
8.2.2	Biosynthesis of the Hop Resins	265
8.2.3	Analysis of the Hop Resins	267
8.2.4	Isomerization of the α -Acids	269
8.2.5	Hard Resins and Prenylflavonoids	277
8.2.6	Oxidation of the Hop Resins	280
8.3	Hop Oil	283
8.3.1	Introduction	283
8.3.2	Hydrocarbons	286
8.3.3	Oxygen-Containing Components	288
8.3.4	Sulphur-Containing Compounds	295
8.3.5	Most Potent Odorants in Hop Oil	297
8.3.6	Hop Oil Constituents in Beer	298
8.3.7	Post Fermentation Aroma Products	300

8.4	Hop Polyphenols (Tannins)	301
8.5	Chemical Identification of Hop Cultivars	302
8.6	References	303
9.	Chemistry of Wort Boiling	306
9.1	Introduction	306
9.2	Carbohydrates	307
9.3	Nitrogenous Constituents	307
	9.3.1 Introduction	307
	9.3.2 Proteins	309
9.4	Carbohydrate-Nitrogenous Constituent Interactions	311
	9.4.1 Melanoidins	319
	9.4.2 Caramel	320
9.5	Protein-Polyphenol (Tannin) Interactions	322
9.6	Copper Finings and Trub Formation	322
9.7	References	324
10.	Wort Boiling, Clarification, Cooling and Aeration	326
10.1	Introduction	326
10.2	The Principles of Heating Wort	328
10.3	Types of Coppers	332
10.4	The Addition of Hops	341
10.5	Pressurized Hop-Boiling Systems	342
	10.5.1 Low-Pressure Boiling	342
	10.5.2 Dynamic Low-Pressure Boiling	343
	10.5.3 Continuous High-Pressure Boiling	343
10.6	The Control of Volatile Substances in Wort	343
10.7	Energy Conservation and the Hop-Boil	345
10.8	Hot Wort Clarification	349
10.9	Wort Cooling	356
10.10	The Cold Break	358
10.11	Wort Aeration/Oxygenation	359
10.12	References	360

11. Yeast Biology	363
11.1 Historical Note	363
11.2 Taxonomy	366
11.3 Yeast Ecology	369
11.4 Cellular Composition	371
11.5 Yeast Morphology	372
11.6 Yeast Cytology	373
11.6.1 Cell Wall	374
11.6.2 The Periplasm	379
11.6.3 The Plasma Membrane	379
11.6.4 The Cytoplasm	380
11.6.5 Vacuoles and Intracellular Membrane Systems	381
11.6.6 Mitochondria	382
11.6.7 The Nucleus	382
11.7 Yeast Cell Cycle	384
11.7.1 Yeast Sexual Cycle	387
11.8 Yeast Genetics	389
11.8.1 Methods of Genetic Analysis	390
11.8.2 The Yeast Genome	393
11.9 Strain Improvement	395
11.10 References	399
12. Metabolism of Wort by Yeast	401
12.1 Introduction	401
12.2 Yeast Metabolism – an Overview	404
12.3 Yeast Nutrition	406
12.3.1 Water Relations	407
12.3.2 Sources of Carbon	409
12.3.3 Sources of Nitrogen	410
12.3.4 Sources of Minerals	410
12.3.5 Growth Factors	410

12.4	Nutrient Uptake	411
12.4.1	Sugar Uptake	412
12.4.2	Uptake of Nitrogenous Nutrients	415
12.4.3	Lipid Uptake	416
12.4.4	Ion Uptake	416
12.4.5	Transport of the Products of Fermentation	418
12.5	Sugar Metabolism	418
12.5.1	Glycolysis	418
12.5.2	Hexose Monophosphate (Pentose Phosphate) Pathway	421
12.5.3	Tricarboxylic Acid Cycle	422
12.5.4	Electron Transport and Oxidative Phosphorylation	425
12.5.5	Fermentative Sugar Catabolism	428
12.5.6	Gluconeogenesis and the Glyoxylate Cycle	430
12.5.7	Storage Carbohydrates	430
12.5.8	Regulation of Sugar Metabolism	434
12.5.9	Ethanol Toxicity and Tolerance	438
12.6	The Role of Oxygen	440
12.7	Lipid Metabolism	442
12.7.1	Fatty Acid Metabolism	443
12.7.2	Phospholipids	445
12.7.3	Sterols	447
12.8	Nitrogen Metabolism	449
12.9	Yeast Stress Responses	453
12.10	Minor Products of Metabolism Contributing to Beer Flavour	454
12.10.1	Organic and Fatty Acids	454
12.10.2	Carbonyl Compounds	456
12.10.3	Higher Alcohols	459
12.10.4	Esters	460
12.10.5	Sulphur-Containing Compounds	462
12.11	References	465

13. Yeast Growth	469
13.1 Introduction	469
13.2 Measurement of Yeast Biomass	470
13.3 Batch Culture	474
13.3.1 Brewery Batch Fermentations	477
13.3.2 Effects of Process Variables on Fermentation Performance	478
13.4 Yeast Ageing	482
13.5 Yeast Propagation	483
13.5.1 Maintenance and Supply of Yeast Cultures	484
13.5.2 Laboratory Yeast Propagation	486
13.5.3 Brewery Propagation	487
13.6 Fed-Batch Cultures	490
13.7 Continuous Culture	492
13.8 Immobilized Yeast Reactors	495
13.9 Growth on Solid Media	497
13.10 Yeast Identification	498
13.10.1 Microbiological Tests	498
13.10.2 Biochemical Tests	499
13.10.3 Tests Based on Cell Surface Properties	500
13.10.4 Non-Traditional Methods	501
13.11 Measurement of Viability	502
13.12 Assessment of Yeast Physiological State	504
13.13 References	506
14. Fermentation Technologies	509
14.1 Introduction	509
14.2 Basic Principles of Fermentation Technology	510
14.2.1 Fermentability of Wort	510
14.2.2 Time Course of Fermentation	511
14.2.3 Heat Output in Fermentation	512
14.3 Bottom Fermentation Systems	514
14.3.1 Choice, Size and Shape of Vessels	514

14.3.2	Construction of Cyindroconical Vessels	516
14.3.3	Operation of Cyindroconical Vessels	519
14.4	Top Fermentation Systems	526
14.4.1	Traditional Top Fermentation	526
14.4.2	Yorkshire Square Fermentation	529
14.4.3	Burton Union Fermentation	531
14.5	Continuous Fermentation	532
14.5.1	Early Systems of Continuous Fermentation	533
14.5.2	The New Zealand System	535
14.5.3	Continuous Primary Fermentation with Immobilized Yeast	535
14.6	Fermentation Control Systems	539
14.6.1	Specific Gravity Changes	539
14.6.2	Other Methods	540
14.7	Summary	541
14.8	References	541
15.	Beer Maturation and Treatments	543
15.1	Introduction	543
15.2	Maturation: Flavour and Aroma Changes	544
15.2.1	Principles of Secondary Fermentation	544
15.2.2	Important Flavour Changes	545
15.2.3	Techniques of Maturation	547
15.2.4	Flavour, Aroma and Colour Adjustments by Addition	549
15.2.5	Maturation Vessels	552
15.3	Stabilization against Non-Biological Haze	555
15.3.1	Mechanisms for Haze Formation	555
15.3.2	Removal of Protein	556
15.3.3	Removal of Polyphenols	559
15.3.4	Combined Treatments to Remove Protein and Polyphenols	561
15.3.5	Hazes from Other Than Protein or Polyphenols ...	561

15.4	Carbonation	562
15.4.1	Carbon Dioxide Saturation	562
15.4.2	Carbon Dioxide Addition	564
15.4.3	Carbon Dioxide Recovery	565
15.5	Clarification and Filtration	567
15.5.1	Removal of Yeast and Beer Recovery	567
15.5.2	Beer Filtration	574
15.6	Special Beer Treatments	582
15.6.1	Low-Alcohol and Alcohol-Free Beers	582
15.6.2	Ice Beers	585
15.6.3	Diet Beers	586
15.7	Summary	587
15.8	References	587
16.	Native African Beers	589
16.1	Introduction	589
16.1.1	An Outline of the Stages of Production	590
16.1.2	Bouza	590
16.1.3	Merissa	591
16.1.4	Busaa and Some Other Beers	591
16.1.5	Southern African Beers	592
16.2	Malting Sorghum and Millets	593
16.3	Brewing African Beers on an Industrial Scale	597
16.4	Attempts to Obtain Stable African Beers	601
16.5	Beer Composition and Its Nutritional Value	602
16.6	References	604
17.	Microbiology	606
17.1	Introduction	606
17.2	The Microbiological Threat to the Brewing Process	607
17.3	Beer Spoilage Micro-Organisms	610
17.3.1	Detection of Brewery Microbial Contaminants	610
17.3.2	Identification of Brewery Bacteria	613
17.3.3	Gram Negative Beer Spoiling Bacteria	614

17.3.4	Gram Positive Beer Spoiling Bacteria	621
17.3.5	Beer Spoilage Yeasts	625
17.3.6	Microbiological Media and the Cultivation of Micro-Organisms	628
17.4	Microbiological Quality Assurance	632
17.5	Sampling	634
17.5.1	Sampling Devices	634
17.6	Disinfection of Pitching Yeast	636
17.7	Cleaning in the Brewery	637
17.7.1	Range of Cleaning Operations	640
17.7.2	CIP Systems	643
17.7.3	Cleaning Agents	644
17.7.4	Cleaning Beer Dispense Lines	647
17.7.5	Validation of CIP	648
17.8	References	648
18.	Brewhouses: Types, Control and Economy	650
18.1	Introduction	650
18.2	History of Brewhouse Development	650
18.2.1	The Tower Brewery Lay-Out	651
18.2.2	The Horizontal Brewery Lay-Out	653
18.3	Types of Modern Brewhouses	654
18.3.1	Experimental Brewhouses	654
18.3.2	Micro- and Pub Breweries	655
18.4	Control of Brewhouse Operations	657
18.4.1	Automation in the Brewhouse	657
18.4.2	Scheduling of Brewhouse Operations	658
18.5	Economic Aspects of Brewhouses	660
18.6	Summary	661
18.7	References	661
19.	Chemical and Physical Properties of Beer	662
19.1	Chemical Composition of Beer	662
19.1.1	Inorganic Constituents	664

19.1.2	Alcohol and Original Extract	666
19.1.3	Carbohydrates	670
19.1.4	Other Constituents Containing Carbon, Hydrogen and Oxygen	672
19.1.5	Nitrogenous Constituents	685
19.1.6	Sulphur-Containing Constituents	691
19.2	Nutritive Value of Beer	694
19.3	Colour of Beer	695
19.4	Haze	697
19.4.1	Measurement of Haze	698
19.4.2	Composition and Formation of Haze	699
19.4.3	Prediction of Haze and Beer Stability	700
19.4.4	Practical Methods for Improving Beer Stability	702
19.5	Viscosity	702
19.6	Foam Characteristics and Head Retention	703
19.6.1	Methods of Assessing Foam Characteristics	704
19.6.2	Beer Components Influencing Head Retention	707
19.6.3	Head Retention and the Brewing Process	709
19.7	Gushing	710
19.8	References	712
20.	Beer Flavour and Sensory Assessment	716
20.1	Introduction	716
20.2	Flavour – Taste and Odour	717
20.3	Flavour Stability	728
20.4	Sensory Analysis	733
20.5	References	757
21.	Packaging	759
21.1	Introduction	759
21.2	General Overview of Packaging Operations	760
21.3	Bottling	761
21.3.1	Managing the Bottle Flow	762
21.3.2	Managing the Beer Flow	770

21.3.3	Managing Plant Cleaning	785
21.3.4	Materials for Making Bottles	786
21.4	Canning	787
21.4.1	The Beer Can	787
21.4.2	Preparing Cans at the Brewery for Filling	788
21.4.3	Can Filling	789
21.4.4	Can Closing (Seaming)	790
21.4.5	Widgets in Cans	792
21.5	Kegging	792
21.5.1	The Keg	793
21.5.2	Treatment of Beer for Kegging	794
21.5.3	Handling of Kegs	796
21.5.4	Keg Internal Cleaning and Filling	797
21.5.5	Keg Capping and Labeling	802
21.5.6	Smooth Flow Ale in Kegs	803
21.6	Cask Beer	805
21.6.1	The Cask	805
21.6.2	Handling Casks	806
21.6.3	Preparing Beer for Cask Filling	807
21.6.4	Cask Filling	808
21.7	Summary	809
21.8	References	810
22.	Storage and Distribution	812
22.1	Introduction	812
22.2	Warehousing	812
22.2.1	Principles of Warehouse Operation	813
22.2.2	Safety in the Warehouse	814
22.3	Distribution	815
22.3.1	Logistics	815
22.3.2	Quality Assurance	817
22.4	Summary	818
22.5	References	818

23. Beer in the Trade	819
23.1 Introduction	819
23.2 History	820
23.3 Beer Cellars	820
23.3.1 Hygiene	820
23.3.2 Temperature	821
23.3.3 Lighting	821
23.4 Beer Dispense	821
23.4.1 Keg Beer	822
23.4.2 Cask Beer	824
23.4.3 Bottled and Canned Beer	830
23.5 Quality Control	830
23.6 New Developments in Trade Quality	830
23.7 Summary	831
23.8 References	831
Appendix: Units and Some Data of Use in Brewing	832
Table A1. SI Derived Units	833
Table A2. Prefixes for SI Units	834
Table A3. Comparison of Thermometer Scales	835
Table A4. Interconversion Factors for Units of Measurement	837
Table A5. Specific Gravity and Extract Table	838
Table A6. Equivalence between Institute of Brewing Units of Hot Water Extract	841
Table A7. Solution Divisors of Some Sugars	842
Table A8. Some Properties of Water at Various Temperatures	842
Table A9. The Density and Viscosity of Water at Various Temperatures	842
Table A10. Some More Properties of Water	843
Table A11. The Relationship Between the Absolute Pressure and the Temperature of Water-Saturated Steam	843

Table A12. The Solubility of Pure Gases in Water at Different Temperatures	844
Table A13. Salts in Brewing Liquors	844
Table A14. Units of Degrees of Water Hardness	845
Table A15. Characteristics of Some Brewing Materials	845
Table A16. Pasteurization Units	846
Fig. A1. The Relationships between Ethanol/Water Mixtures and the Densities of the Solutions	847
References	847
Index	848

1

An outline of brewing

1.1 Introduction

Beers and beer-like beverages may be prepared from raw cereal grains, malted cereal grains and (historically) bread. This book is primarily concerned with beers of the types that originated in Europe, but which are now produced world-wide. However, an account is given of 'African-style' beers (Chapter 16). The most simple preparation of European-style beers involves (a) incubating and extracting malted, ground up cereal grains (usually barley) with warm water. Sometimes the ground malt is mixed with other starchy materials and/or enzymes. (b) The solution obtained is boiled with hops or hop preparations. (c) The boiled solution is clarified and cooled. (d) The cooled liquid is fermented by added yeast. Usually the beer is clarified, packaged and served while effervescent with escaping carbon dioxide. In this chapter the preparation of beers is outlined and the brewers' vocabulary is introduced. Beers are made in amounts ranging from a few hectolitres (hl) a week to thousands of hl. They are made using various different systems of brewing.

1.2 Malts

Malts are made from selected cereal grain, usually barley, (but sometimes wheat, rye, oats, sorghum or millet), that has been cleaned and stored until dormancy has declined and it is needed. It is then germinated under controlled conditions. Their preparation is outlined in Chapter 2, and is described in detail in Briggs (1998). The grain is hydrated, or 'steeped', by immersion in water. During steeping the water will be changed at least once, air may be sucked through the grain during 'dry' periods between immersions, and may be blown into the grain while immersed. After steeping the grain is drained and is germinated to a limited extent in a cool, moist atmosphere with occasional turning and mixing to prevent the rootlets matting together. During germination the acrospire (coleoptile) grows beneath the husk and rootlets grow from the end of the grain, enzymes accumulate and so do sugars and other soluble materials. The dead storage tissue of the grain, the starchy endosperm, is partly degraded, or 'modified', and its physical strength

2 Brewing: science and practice

is reduced. When germination and ‘modification’ are sufficiently advanced they are stopped by kilning. The ‘green malt’ (green in the sense of immature, it is not green in colour) is kilned, that is, it is dried and lightly cooked, or cured, in a current of warm to hot air. Pale, ‘white’ malts are kilned using low temperatures and in these enzyme survival is considerable. In darker, coloured malts, kilned using higher temperatures, enzyme survival is less. In extreme cases the darkest, special malts are heated in a roasting drum and contain no active enzymes. After kilning the malt is cooled and ‘dressed’, that is, the brittle rootlets (‘culms’, sprouts) are broken off and they and dust are removed. The culms are usually used for cattle food. Pale malts are usually stored for some weeks before use. In contrast to the tough, ungerminated barley grain malt is ‘friable’, that is, it is easily crushed.

1.3 Mash tun adjuncts

Mash tun adjuncts are preparations of cereals (e.g., flaked maize or rice flakes, wheat flour, micronized wheat grains, or rice or maize grits which have to be cooked separately in the brewery) which may be mixed with ground malt in the mashing process. The use of an adjunct alters the character of the beer produced. An adjunct’s starch is hydrolysed during mashing by enzymes from the malt, so providing a (sometimes) less expensive source of sugars as well as changing the character of the wort. Sometimes microbial enzymes are added to the mash. In a few countries the use of adjuncts is forbidden. In Germany the *Reinheitsgebot* stipulates that beer may be made only with water, malt, hops and yeast.

1.4 Brewing liquor

In brewing, water is commonly known as liquor. It is used for many purposes besides mashing, including beer dilution at the end of high-gravity brewing, cleaning and in raising steam. Water for each purpose must meet different quality criteria (Chapter 3). The brewing liquor used in mashing must be essentially ‘pure’, but it must contain dissolved salts appropriate for the beer being made. The quality of the liquor influences the character of the beer made from it. Famous brewing locations gained their reputations, at least in part, from the qualities of the liquors available to them. Thus Burton-on-Trent is famous for its pale ales, Dublin for its stouts and Pilsen for its fine, pale lagers. It is now usual, at least in larger breweries, to adjust the composition of the brewing liquor (Chapter 3).

1.5 Milling and mashing in

The malt, sometimes premixed with particular adjuncts, is broken up to a controlled extent by milling to create the ‘grist’. The type of mill used and the extent to which the malt (and adjunct) is broken down is chosen to suit the types of mashing and wort-separation systems being used (Chapter 5). If dry milling is used the grist, possibly mixed with adjuncts, is collected in a container, the grist case.

At mashing-in (doughing-in) the grist is intimately mixed with brewing liquor, both flowing at controlled rates, into a mashing vessel at an exactly controlled temperature.

The resulting ‘mash’, with the consistency of a thin slurry, is held for a period of ‘conversion’. The objective is to obtain a mash that will yield a suitable ‘sweet wort’, a liquid rich in materials dissolved from the malt and any adjuncts that have been used. The dissolved material, the ‘extract’, contains soluble substances that were preformed in the grist and other substances (especially carbohydrates derived from starch), that are formed from previously insoluble materials by enzyme-catalysed hydrolytic breakdown during mashing.

1.6 Mashing and wort separation systems

The major mashing systems are, broadly, (a) the simplest, nearly isothermal, infusion mashing system, (traditional for British ale brewers); (b) the decoction system, (traditional for mainland European lager brewers); (c) the double mash system, (common in North American practice); (d) the temperature-programmed infusion mashing system that is being widely adopted in the UK and mainland Europe (Chapters 4 and 5). A mash should be held at a chosen temperature (or at successive different temperatures), for pre-determined times, to allow enzymes to ‘convert’ (degrade) the starch and dextrans to soluble sugars, to cause the partial breakdown of proteins, to degrade nucleic acids and other substances. At the end of mashing the sweet, or unhopped wort (the solution of extractives, mainly carbohydrates; the ‘extract’) is separated from the undissolved solids, the spent grains or draff.

Infusion mashing is carried out in mash tuns. Mash conversion and the separation of the sweet wort from the spent grains take place in this vessel. The coarsely ground grist, made with a high proportion of well-modified malt, is mashed in to give a relatively thick, porridge-like mash at 63–67 °C (145.4–152.6 °F). After a stand of between 30 minutes and two and a half hours the wort (liquid) is withdrawn from the mash. The first worts are cloudy and are re-circulated, but as the run off is continued the wort becomes ‘bright’ (clear), because it is filtered through the bed of grist particles. When bright the wort is either collected in a holding vessel (an underback) or it is moved directly to a copper to be boiled with hops. Most of the residual extract, initially entrained in the wet grains, is washed out by sparging (spraying) hot liquor, at 75–80 °C (167–176 °F) over the goods.

Decoction mashing is carried out with more finely ground grists, originally made with malts that were undermodified. These mashes are relatively ‘thin’, so they may be moved by pumping and can be stirred. Decoction mashing uses three vessels, a stirred mash mixing vessel, a stirred decoction vessel or mash cooker and a wort separation device, either a lauter tun or a mash filter. In one traditional mashing programme the grist is mashed in to give an initial temperature of around 35 °C (96 °F). After a stand a decoction is carried out, that is, a proportion of the mash, e.g., a third, is pumped to the mash cooker, where it is heated to boiling. The boiling mash is pumped back to the mash mixing vessel and is mixed with the vessels contents, raising the temperature to, e.g., 50 °C (122 °F). After another stand a second decoction is carried out, increasing the temperature of the mixed mash to about 65 °C (149 °F). A final decoction increases the mash temperature to about 76 °C (167 °F). The mash is then transferred to a lauter tun or a mash filter. The sweet wort and spargings are collected, ready to be boiled with hops.

Typically, double-mashing uses nitrogen- (‘protein-’) and enzyme-rich malts and substantial quantities of maize or rice grits. It also involves the use of three vessels. Most of the malt grist is mashed into a mash-mixing vessel to give a mash at around 38 °C

(100.4 °F). The grits, mixed with a small proportion of ground malt and/or a preparation of microbial enzymes, are mashed in a separate vessel called a cereal cooker. The contents are carefully heated with mixing, and a rest at about 70 °C (158 °F), to 100 °C (212 °F) to disperse the starch and partly liquefy it. The adjunct mash is pumped from the cereal cooker into the malt mash, with continuous mixing, to give a final temperature of about 70 °C (158 °F). After a stand the mash is heated to about 73 °C (163.4 °F), then it is usually transferred to a lauter tun for wort collection.

Temperature-programmed infusion mashing is increasingly displacing older mashing systems. The grist is finely ground and the mash is made 'thin' to allow it to be stirred. The grist is mashed into a stirred and externally heated mash-mixing vessel to give an initial temperature of 35 °C (95 °F) for a poorly modified malt or 50 °C (122 °F), or more, for a better modified malt. The mash is heated, with 'stands' typically at 50 °C (122 °F), 65 °C (149 °F) and 75 °C (167 °C). Then the sweet wort is collected using a lauter tun or a mash filter.

1.7 The hop-boil and copper adjuncts

The sweet wort is transferred to a vessel, a copper or kettle, in which it is boiled with hops or hop preparations, usually for 1–2 hours. Hops are the female cones of hop plants. They may be used whole, or ground up, or as pellets or as extracts. The choice dictates the type of equipment used in the next stage of brewing. Pelleted powders are often preferred. Hops contribute various groups of substances to the wort. During boiling a number of changes occur in the wort of which the more obvious are the coagulation of protein as 'hot break' or 'trub', the gaining of bitterness and hop aroma and the destruction of micro-organisms (Chapters 9 and 10). Evaporation of the wort, reduces the volume by, say, 7–10%, and so it is concentrated. Unwanted flavour-rich and aromatic volatile substances are removed. When used, sugars, syrups and even malt extracts (copper adjuncts) are dispersed and dissolve in the wort during the copper boil. During the boil flavour changes and a darkening of the colour occurs. Caramels may be added at this stage to adjust the colour. The hop-boil consumes about half of the energy use in brewing.

1.8 Wort clarification, cooling and aeration

At the end of the boil the transparent, or 'bright' wort contains flocs of trub (the hot break) and suspended fragments of hops. If whole hops were used then residual solids are strained off in a hop back or other filtration device and the bed of hop cones filters off the trub, giving a clear, hopped wort. However, if powders, hop pellets, (which break up into small particles), or extracts were used then hop fragments (if present) and the trub are usually separated in a 'whirlpool tank'. The clear 'hopped wort' is cooled to check continuing darkening and flavour changes and so it can be inoculated ('pitched') with yeast, and can be aerated or oxygenated without a risk of oxidative deterioration. The heated cooling water is used for various purposes around the brewery. During cooling a second separation of solids occurs in the wort. This 'cold break' is composed mostly of proteins and polyphenols and some associated lipids. It is often, but not always, considered desirable to remove this material to give a 'bright', completely clear wort. The wort is aerated or even oxygenated, to provide oxygen for the yeast in the initial stages of fermentation.

1.9 Fermentation

Fermentation may be carried out in many different types of vessel (Chapter 14; Boulton and Quain, 2001). Fermenters may be open or completely closed or they may allow part of the yeast to be exposed to the air for part of the fermentation period. The variety of fermenters remains because yeasts working in different vessels produce beers with different flavours. Wort fermentation is initiated by pitching (inoculating) the cooled, hopped wort with a selected yeast. In a few cases mixtures of yeasts are used. Brewery yeast is a mass of tiny, single, ovoid cells (*Saccharomyces cerevisiae*, the ‘sugar fungus of beer’). Yeast strains vary in their properties and the flavours they impart. In a very few cases, as with Belgian Gueuze and Lambic beers, (or some African beers; Chapter 16), fermentation occurs ‘spontaneously’ and a complex mixture of microbes is involved. The yeast metabolizes extract substances dissolved in the wort. More yeast cells and ‘minor’ amounts of many substances are produced, some of which add to the beer’s character. The major products of carbohydrate metabolism are ethyl alcohol (ethanol), carbon dioxide and heat. The yeast multiplies around 3–5 times. Some is retained for use in subsequent fermentations, while the surplus is disposed of to distillers or the makers of yeast extracts.

Traditionally, ales are fermented with ‘top yeasts’ which rise to the top of the beer in the head of foam. These are pitched at about 16 °C (61 °F) and fermentation is carried out at 15–20 °C (59–68 °F) for 2–3 days. Traditional lagers are fermented with ‘bottom yeasts’, which settle to the base of the fermenter. These are pitched at lower temperatures (e.g., 7–10 °C; 44.6–50 °F) and fermentations are also carried out at lower temperatures (e.g., 10–15 °C; 50–59 °F), consequently they take longer than ale fermentations. As wort is converted into beer the removal of materials (especially sugars) from solution and the appearance of ethanol both contribute to the decline in specific gravity. The initial or original gravity, OG, the final or present gravity at the end of the fermentation, FG or PG, and the final alcohol content, are important characteristics of beers.

Yeasts are selected with reference to:

1. their rate and extent of growth
2. the rate and extent of fermentation
3. the flavour and aroma of the beer produced
4. in older fermentation systems it is imperative that top yeasts rise into a good head of foam and bottom yeasts sediment cleanly.

Substances (finings) may be added to promote yeast separation at the end of fermentation. However, in some modern systems ‘powdery’ yeasts are employed that stay in suspension until the beer is chilled or until collected by centrifugation.

1.10 The processing of beer

When the main, or ‘primary’ fermentation is nearly complete the yeast density is reduced to a pre-determined value. The ‘green’ or immature beer (it is not green in colour, but has an unacceptable, ‘immature’ flavour) is held for a period of maturation or secondary fermentation. During this process the flavour of the mature beer is refined. Sometimes ‘priming’ sugar or a small amount of wort is added to boost yeast metabolism and the ‘maturation’, ‘conditioning’ or ‘lagering’ process. (*Lagern* is German and means stored or deposited). In traditional lager brewing the immature beer was stored cold, e.g., at

−2 °C (28.4 °F), for extended periods, sometimes months, when a very slow secondary fermentation occurred and yeast and cold trub settled to the base of the storage vessel. Conditioning is carried out in various ways. The primary and secondary fermentations were carried out in separate, special vessels but increasingly single vessels are used. Traditionally, ales are run from fermenters into casks or bottles with a little sugar, finings and a regulated amount of yeast. The secondary fermentation ‘conditions’ the beer in the container, charging it with carbon dioxide. The ale is dispensed from above a layer of settled yeast. Such naturally conditioned beers are now made in only small amounts. These beers are not stable for extended periods and they require careful, intelligent handling.

Now, after conditioning in bulk, most beers are chilled and filtered or centrifuged to remove residual yeast. These completely bright beers are then carbonated, that is, their carbon dioxide content is adjusted, they are transferred into bottles, cans, kegs, or bulk tanks. Nitrogen gas is sometimes added to the package, so the beer contains both this and carbon dioxide, but as far as possible air is excluded. Before packaging the beer may be sterile filtered, a process that avoids flavour damage but it follows that all subsequent beer movements must be made under rigidly aseptic conditions. More often the beer is pasteurized, that is, it is subjected to a carefully regulated heat treatment. This may be applied to the filled bottles or cans or to the flowing beer as it moves to fill a sterile container. With the notable exceptions of some dark stouts and wheat beers, such beers should (a) be brilliantly clear, (b) develop a stable white foam, or head, when poured into a clean glass, and (c) their flavours and gas-contents should remain steady.

The careful selection of raw materials and processing conditions help brewers to approach these objectives. However, it may be necessary to employ other techniques. For example, the plant proteolytic enzyme papain may be added to beer, or the beers may be treated with insoluble adsorbents to remove haze precursors. In addition substances may be added to reduce the dissolved oxygen content of the beer, to maximize its haze and flavour stability. Other substances may be added to stabilize beer foam.

1.11 Types of beer

There is no truly satisfactory classification of beers. ‘Clear, European-style beers’ may be distinguished by the raw materials used in their preparation, the ways in which the brewing operations are carried out, whether top, bottom or ‘bulk’ fermentation is used, how the product is conditioned, whether it is chilled and filtered and carbonated or is conditioned in bottle or cask and how it is packaged. Stouts, porters and wheat beers, which are produced in conventional ways, are often not transparent. A beer may also be distinguished by its OG and degree of attenuation or alcohol content, colour, acidity, flavour and aroma, by its ‘body’ or ‘mouth feel’, by its head (foam) characteristics and by its physiological effects. How a drinker perceives a beer is influenced by many factors, including the manner in which it is served, its temperature, clarity and colour, flavour, aroma and ‘character’, the ambience, and whether or not it is being taken with food and what has been consumed before.

Within each grouping, ‘class’ or ‘style’, individual beers may be quite distinct and brewers aim to produce distinctive products. In North America most beer is pale, lightly hopped and served very cold (often at about 0 °C; 32 °F). Many new, small breweries have been set up and these make a wide variety of beers based on styles from around the world. In Europe, for about a century, British brewing practices diverged from those of mainland

producers, but in recent years convergence has started. For example, in Germany most beers (not all) were made using decoction mashing, bottom fermentation and long periods of cold storage (lagering). Increasingly, temperature programming, infusion mashing, bulk fermentation and shorter periods of lagering are being used. Under many circumstances the use of adjuncts is still not used. Although under EEC legislation the use of adjuncts is allowed, most German brewers still abide by the *Reinheitsgebot* for domestic beers.

The main groups of beers are the very pale Pilsen types, pale golden-brown Vienna types, and the darker, rich Munich types. Other beers include Märzen, Oktoberfest, wheat beers, rye beers and smoked beers. In the UK lager worts are produced in many ways, but they are bottom fermented. The British 'lagers' are all pale beers. Ales are traditionally made with an infusion mashing system. They are moderately strongly hopped and a top fermentation system is used. Traditional groups are the (progressively darker) pale ales, mild ales (usually darker, sweeter and less strongly hopped), brown ales (darker forms of 'mild'), and stouts or 'porters'. The distinctions between ale and lager breweries are increasingly blurred as some brewers adopt similar wort production and fermentation systems.

Less common products include wheat beers, low-alcohol and alcohol-free beers (which may be carbonated worts, underfermented beers or beers from which the alcohol has been removed), and beers with exceptionally high alcohol contents (e.g., barley wines and Trappist beers, with 9% ABV, or more). In low carbohydrate (lite, light or dietetic) beers, prepared by using special mashing conditions and added starch-degrading enzymes, essentially all the starch-derived dextrans are degraded to fermentable sugars and are utilized by the yeast. African opaque beers (Chapter 16) and kvass (Russian) are distinct products. Some unusual beers, made in Belgium, include Lambic, Gueuze and fruit-flavoured beers (kriek, flavoured with cherries; framboise, flavoured with raspberries). These are all made using spontaneous fermentations which involve mixtures of organisms.

Beer strength may be defined in several ways; by the specific gravity of the wort before fermentation (the OG), by the alcohol content of the final beer (% alcohol by volume or ABV) or even by the content of hop bitter substances. The fermentability of extract depends on many factors. There is no fixed relationship between the OG and the alcohol content of a beer. In Britain the specific gravity of a wort or beer is usually quoted *times* 1,000 so, for example, water has a SG of 1000.00 and wort with a specific gravity (s.g.) of 1.040 at 20°C (68°F) has a SG of 1040.00. In the past, extract was calculated as brewer's pounds per barrel, and the excess weight (in lb.) over water was referred to as brewer's pounds gravity. Thus a barrel of water (36 imp. gallons, UK) weighs 360 pounds (lb.), but a barrel of wort at SG 1040 weighed 374.2 lb. So this wort had a gravity of 14.2 lb. Outside the UK concentrations are often expressed in terms of concentrations of sucrose solutions of the same gravity (see appendix). Thus, in von Balling's tables of 1843 wort of a specific gravity of 1040 is equivalent to a sucrose solution of 9.95% (w/w). Von Balling's tables were revised by Plato in 1918 and gravity is often expressed as degrees Plato. Increasingly beer strengths are being given as the concentration of alcohol % ABV that they contain.

1.12 Analytical systems

For both trading and quality-control purposes all the materials used in making beers, the liquor, the sweet and hopped worts and the beers themselves are analysed. Not all the methods used are standardized and, regrettably, there are at least four 'agreed', but

discordant, sets of methods in use. The methods used in the different sets differ significantly and give different results. In many instances there are no valid or reliable conversion factors to interconvert analytical results. The most commonly used methods are those of the Institute of Brewing (IoB; now the Institute and Guild of Brewing, IGB), the European Brewery Convention (EBC), the American Society of Brewing Chemists (ASBC) and the methods of the *Mitteuropäischen Analysen Kommission* (MEBAK). The methods are frequently revised, successive versions being distinguished by their dates. In this book the most recent units are used wherever possible. By 2005 the methods of the IGB and the EBC should have been merged. The number of units of measurement in use is large. Here metric units have been used where possible, with British (UK) equivalents so, for example, hectolitres and imperial gallons. It should be noted that the American gallon (US) has only about 0.8 of the volume of an imperial gallon. Systems of units and conversion factors are given in the Appendix.

1.13 The economics of brewing

The economics of brewing are influenced by many factors, including the manning levels required, the local costs of labour, raw materials, how brewing practices are influenced by governmental regulations and how the products are taxed. The scales of brewery operations vary widely, from units that produce < 10 barrels (imp. brl, approx. 16.4 hectolitres, hl) per week to > 30,000 imp. brl (49,092 hl) per week. Thus savings per imp. brl that are trivial to the small-scale brewer are worthwhile to a larger operator. Breweries that operate continuously, for 24 hours a day, use their capital investment in plant to the best effect and they can also make other savings, for example, by using heat-recovery systems that are not suitable for breweries that operate intermittently. There are strong and increasing pressures to minimize water use, to minimize the production of wastes and effluents and the release of heat and odorous gases (such as vapours from hop-boiling), and 'greenhouse gases' such as carbon dioxide and refrigerants, to utilize raw materials as efficiently as possible, and to utilize fuels and power efficiently.

In order to use plant at peak efficiency it is necessary to have it well engineered, instrumented, automated and maintained so that it can operate nearly continuously. To make such investment worthwhile the capacity of the plant must be large and, in consequence, the manpower needed to produce a given volume of beer is lower than is needed with less sophisticated plant. The personnel needed to operate modern plant successfully must be highly trained. Such plant is most efficient at making large volumes of relatively few beers. Smaller, more labour-intensive plants are often better suited for making a wide variety of beers in smaller amounts. Large brewing companies tend to produce fewer beers in larger and larger plants. The problems of 'product matching', of trying to make large volumes of one beer in different breweries, are notorious. Smaller breweries, making smaller volumes, often of more 'specialist', and even 'eccentric' beers, are appearing all the time. Smaller breweries usually deliver beer over a small area, and so have lower transportation costs relative to larger breweries, which must deliver to larger areas to market the larger amounts of beer that they produce.

Energy and water requirements per unit volume of beer produced vary widely. In part this is due to differences in the efficiencies of production plants, but it also depends on the production processes used and on how the beer is packaged. Thus decoction mashing uses more energy than temperature-programmed infusion mashing. Not all breweries recover heat from the vapours in their mash-cooker or copper-stacks, and the efficiency

of heat recovery varies with the sophistication of the equipment used. The heat, power and water usage in bottling and canning halls (which not all breweries have) is high, because of the amount of washing carried out, the conveying and the heat used by the pasteurizers.

A widely adopted technique for improving the economics of a brewery is ‘high gravity’ (HG) brewing, in which concentrated worts are produced and processed. The concentrated beers produced are diluted for sale. Thus a larger volume of beer is produced, per brew, than would have been the case had the plant been operated in the conventional way. HG brewing is a technically sophisticated process. There are difficulties with preparing concentrated worts unless the addition of sugars or syrups to the copper is allowed. Almost all the stages of the brewing process have to be adjusted, and the water used to dilute the HG beer must be very carefully sterilized, deoxygenated and carbonated.

1.14 Excise

Beer is usually taxed. In Britain malt was taxed and the regulations imposed, to maximize the tax receipts, fossilized the malting and brewing processes. The malt tax was withdrawn in 1880, but the styles of beers that had been produced using well modified ale malts were established as ‘traditional’ and continued in use. Only recently have newer methods of brewing been widely adopted. Next, tax was levied on the gravity and volume of the brewer’s wort, after boiling and cooling. The consequent economic need to convert as high a proportion of this wort as possible into saleable beer influenced the designs of fermentation vessels and yeast propagators, the recovery of beer from harvested yeast, from filters, and so on. At present in the UK, and many other countries, excise is levied on the volume and alcohol content (ABV) of the beer leaving the brewery. Sometimes beers are classified according to the alcohol band (range of strengths) in which it falls. Each band is taxed at a different rate and the tax increases with the alcohol content. There are countries where the beer is taxed by volume only.

1.15 References and further reading

1.15.1 The systems of malting and brewing analysis

- ASBC (1992) *The American Society of Brewing Chemists. Methods of analysis* (8th edn, revised), ASBC, St. Paul, Minn.
- EBC (1997; 1998) *European Brewery Convention. Analytica-EBC* (5th edn, with revisions), Fachverlag Hans Carl, Nürnberg.
- IoB (1997) *The Institute of Brewing, Recommended Methods of Analysis* (2 volumes, and revisions), The Institute and Guild of Brewing, London.
- MEBAK (1993) *Brautechnische Analysenmethoden: Methodensammlung der Mitteleuropäischen Brautechnischer Analysenkommission* (5 volumes).

1.15.2 General

- BAMFORTH, C. W. (1998) *Beer; tap into the art and science of brewing*, London, Insight Press, 245 pp.
- BAMFORTH, C. W. (2002) *Standards of Brewing: a practical approach to consistency and excellence*, Boulder, Colorado, Brewers’ Publications, 209 pp.
- BOULTON, C. and QUAIN, D. (2001) *Brewing Yeast and Fermentation*, London, Blackwell Science, 644 pp.
- BRIGGS, D. E. (1998) *Malts and Malting*, London, Blackie Academic and Professional/Gaithersburg, Aspen Publishing, 796 pp.
- COULTATE, T. P. (2002) *Food, the chemistry of its components*, (4th edn), Cambridge, The Royal Society of Chemistry, 432 pp.

- HLATKY, C. and HLATKY, M. (1997) *Bierbrauen zu Hause*, Graz, Leopold Stocker Verlag, 177 pp.
- HORNSEY, I. S. (1999) *Brewing*, Cambridge, The Royal Society of Chemistry, 231 pp.
- HORNSEY, I. S. (2003) *A History of Beer and Brewing*, Cambridge, The Royal Society of Chemistry, 742 pp.
- KUNZE, W. (1996) *Technology, Brewing and Malting* (International edn, translated Wainwright, T.), Berlin, VLB, 726 pp.
- LEWIS, M. L. and YOUNG, T. W. (2003) *Brewing* (2nd edn), New York, Kluwer Academic, 398 pp.
- MEISEL, D. (1997) *A Practical Guide to Good Lager Brewing Practice*, Hout Bay, South Africa, The Institute of Brewing, Central and Southern African Section.
- MOLL, M. (1994) *Beers and Coolers* (English edn, translated Wainwright, T.), Andover, Intercept, 495 pp.
- SYSILÄ, I. (1997) *Small-Scale Brewing. Brew your own beer*, Helsinki, Limes, 278 pp.
- WAINWRIGHT, T. (1998) *Basic Brewing Science*, Reigate, Wainwright, 317 pp + appendices.

2

Malts, adjuncts and supplementary enzymes

2.1 Grist and other sources of extract

The sources of extract used in brewing are materials used in the mash and materials dissolved during the hop-boil (Chapter 1). In addition, small amounts of sugars may be added to beers as primings or for sweetening. Caramels, coloured malt extracts and *Farbebier* may also be added to adjust colours. Supplementary enzymes, derived from non-malt sources, may be added to the mash or at later stages of beer production. Malt is the traditional source of enzymes and the extract produced in mashing (Chapters 1 and 4). The contents of this chapter are discussed in more detail elsewhere (Briggs, 1998; Brissart *et al.*, 2000).

2.2 Malting

2.2.1 Malting in outline

Barley (*Hordeum vulgare*) is the cereal grain most often malted. Wheat (*Triticum aestivum*) and sorghum (*Sorghum vulgare*) are also malted in notable quantities (the latter in Africa), but small amounts of rye (*Secale cereale*), oats (*Avena sativum*) and millets (various spp.) are also used. The barley grain or corn has a complex structure (Briggs, 1978, 1998, Figs 2.1 and 2.2), and is a single-seeded fruit (a caryopsis). Barley varieties differ in their suitabilities for malting. Barley plants are annual grasses. Some are planted in the autumn (winter barleys) while others are planted in the spring (spring barleys). Grains are arranged in rows, borne on the head, or ear. The number of rows varies, being two in two-rowed varieties and six in six-rowed forms. In mainland Europe winter barleys are usually of poor malting quality, but some of the two-rowed winter varieties grown in the UK (such as Maris Otter, Halcyon and Pearl) are of outstandingly good quality. Good spring malting barleys include Alexis, Chariot, Optic and Prisma. Grains vary in size, shape and chemical composition.

It is important to understand that malts consist of mixtures of grains with differing properties. This heterogeneity, which is reflected in the malt, can give rise to problems in

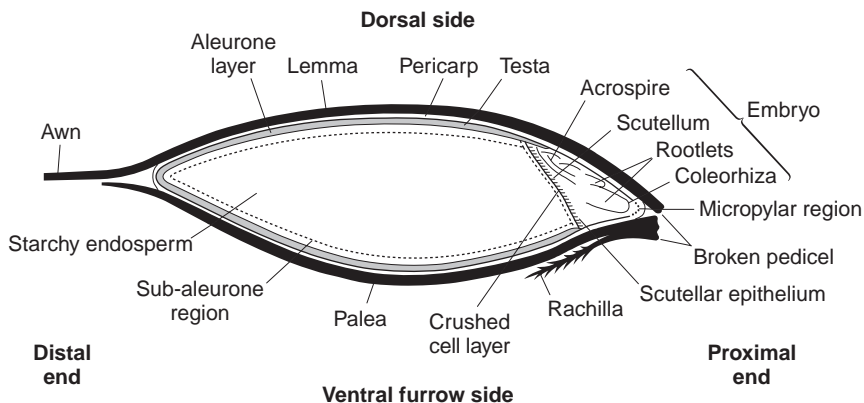

Fig. 2.1 A schematic longitudinal section of a barley grain, to one side of the ventral furrow and the sheaf cells (after Briggs *et al.*, 1981).

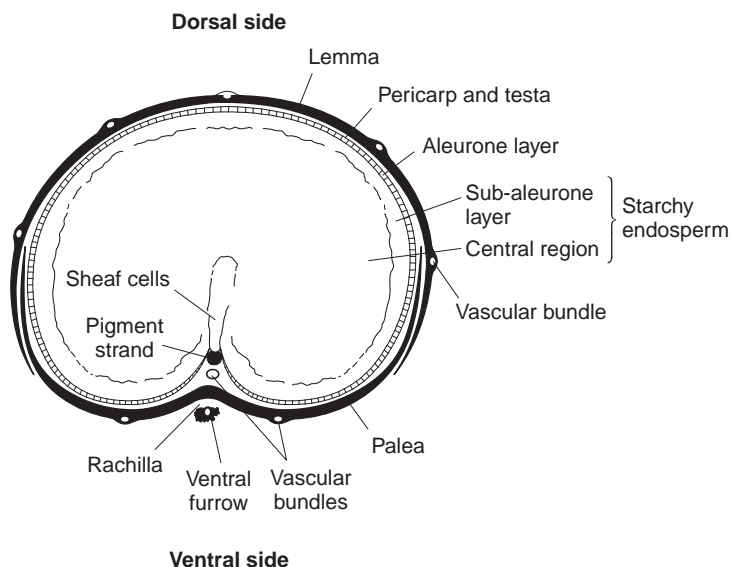

Fig. 2.2 A diagram of a transverse section of a plump barley grain, taken at the widest part (after Briggs *et al.*, 1981).

brewing. Barley dimensions vary, usually in the ranges: lengths, 6–12 mm, 0.24–0.47 in.; widths, 2.7–5.0 mm, 0.11–0.20 in.; thicknesses, 1.8–4.5 mm, 0.07–0.18 in. Two-rowed malting barley grains may have one thousand corn dry weights (TCW) in the range 32–44 g, and some six-rowed barleys have values of about 30 g. Differences between grain sizes must be allowed for when setting brewer’s mills. The barley corn is elongated and tapers at the ends (Figs 2.1, 2.2). The dorsal, or rounded side is covered by the lemma, while the ventral, grooved or furrow side is covered by the palea. Together these units constitute the husk. The lemma has five longitudinal ridges, or ‘veins’ running along it while the palea has two. In threshed grain the apical tip of the lemma is crudely broken off. In the unthreshed grain this is where the extended awn is attached. At the base of the grain, where it was attached to the plant, the rachilla, or basal bristle, lies in the

ventral furrow. Rachillae vary greatly in their shapes and sizes, and are of use in helping to identify grain variety. The husk protects the grain from physical damage. In wheat, rye, sorghum and millets (and in some few 'naked' barleys, which are not malted) husks are absent in threshed grain, so the corns are easily damaged.

Within the husk the multi-layered pericarp also has a protective function. Finally, the testa is the layer that 'seals' the interior of the grain from the exterior and limits the inward and outward movements of dissolved substances, such as sugars, amino acids, salts and proteins. This layer invests the entire interior of the grain except at the embryo, where its structure is modified in the micropylar region, and in the furrow, where the two edges are sealed together by the pigment strand. The testa consists of two cuticularized layers between which polyphenolic proanthocyanidins usually occur. At the base of the grain, over the embryo and between the pericarp and the husk, there are two small, hairy structures, the lodicules. During steeping these may distribute water over the embryo, by capillarity. Their varied forms make them valuable aids in identifying a grain's variety.

Within the testa, at the base of the grain, is the small embryo. This is situated towards the dorsal side of the grain. The embryonic axis consists of the coleoptile (the maltster's 'acrosipre') pointing towards the apex of the grain and the root sheath (coleorhiza) which surrounds several (typically five) embryonic roots. This appears at the end of the grain, at the onset of germination, as the 'chit'. The axis is the part of the embryo that can grow into a small plant. It is recessed into an expanded part of the embryo called the scutellum (Latin, 'little shield'). Unlike the scutellum in oats, in barley this organ does not grow. Its inner surface, which is faced with a specialized epithelial layer, is pressed against the largest tissue of the grain, the starchy endosperm. With the exception of the embryo all the tissues mentioned so far are dead. All the surface structures, outside the testa, are infested with mixed populations of micro-organisms.

The starchy endosperm is a dead tissue of thin-walled cells packed with starch granules embedded in a protein matrix. The granules occur in two size ranges (usually with diameters 1.7–2.5 μm and 22.5–47.5 μm), which behave differently during malting and brewing. The cell walls are mainly β -glucans, with some pentosans and a little holocellulose. This tissue contains most of the grain's reserves, although others are present in the embryo and in the aleurone layer. In transverse section the cell walls radiate outwards from a 'crest' of sheaf cells that run along the grain, above the pigment strand. These sheaf cells are devoid of contents and consist of cell walls pressed together, at least in the dry grain. They are not part of the endosperm tissue, the cell walls of which are more readily degraded by enzymes (Briggs, 2002). The outer region of the starchy endosperm, the sub-aleurone layer, is relatively richer in protein (including β -amylase) and small starch granules but poor in large starch granules. Where the starchy endosperm fits against the scutellum the cells are devoid of contents and the cell walls are pressed together, comprising the crushed-cell or depleted layer. The starchy endosperm, away from the sheaf cells, is surrounded by the aleurone layer (which botanically is also endosperm tissue). On average it is about three cells thick. The cells are alive but do not multiply or grow during germination, have thick cell walls and contain reserves of lipids (fat) and protein, sucrose and possibly fructosans, as well as a full range of functional organelles. They do not contain any starch. A reduced layer of aleurone tissue, a single layer of flattened cells, extends partly over the surface of the embryo. The estimates are approximate, but on a dry weight basis (d.b.) a two-rowed barley corn may consist of husk + pericarp + lodicules, 9–14%; testa, 1–3%; embryo, 2–3.5%; aleurone layer, about 5%; starchy endosperm + sheaf cells, 76–82%. Malting can be understood only by reference to the grain structure and the interactions which occur between the tissues.

Barley is purchased in large amounts. The grain delivered must be of the correct quality, i.e., it must match or exceed in quality a sample seen in advance or an agreed specification. The evaluation of the grain involves both visual and laboratory assessments. Each delivery should be checked before it is unloaded. Delivery may be by railway, barge or (most usually in the UK) by lorry. The grain will be uncovered and inspected for infesting insects, local wetting, admixture of varieties, the presence of ergot sclerotia (poisonous, grain-sized structures produced by the fungus *Claviceps purpurea*), or any sign of heavy fungal attack. If any of these faults is noted the load is likely to be rejected and, if insects are present, the load will be ordered off the premises. With the exception of varieties with blue-pigmented aleurone layers, (which appear greenish as the blue is viewed through the yellow husk), grain should appear 'bright', with a clean straw-yellow colour. Discoloration is caused by heavy microbial contamination.

Samples of the grain bulk are drawn and sent to the laboratory. The moisture content will be determined. In the UK the grain will be inspected to check that it is predominantly (e.g., >97%) of one specified variety, that its viability or germinative capacity (GC; checked by tetrazolium staining) is equal to or exceeds the specified limit (at least 98%) and that the total nitrogen content (TN) or crude protein content ($6.25 \times \text{TN}$) is within specified limits. Grain moisture and nitrogen contents are usually checked using near-infra-red spectroscopy (NIR), but slower methods may be used. The grain will also be checked for 'pre-germination', since grain that has already started to germinate will not keep or malt well. A sample will be graded (screened) by shaking on a set of slotted sieves, usually with slot widths of 2.2 or 2.25, 2.5, and 2.8 mm. In North America the slot sizes are 7/64 in., 6/64 in. and 5/64 in. (about 2.78, 2.38 and 1.98 mm, respectively). The sample must have an acceptable size distribution. Grain, dust and rubbish passing the 2.2 mm or other agreed screen is regarded as 'screenings', or thin corns. It will not be malted and so will have to be removed, collected and sold as animal feed. If screenings exceed a specified weight percentage the load may be rejected or purchased at a reduced price.

Each lorry-load of grain (typically 20–25 t) will be evaluated on a few hundred grams of grain. For the results to have any statistical validity, because of the inherent inhomogeneity of grain, the samples must be drawn, mixed and sub-divided strictly in accordance with the rules set out in the sets of analytical methods (Section 1.15.1, p. 9). If the load is acceptable it will be unloaded and transferred to a 'green grain' store. The grain is not green in appearance but at this stage it has not been pre-cleaned, dried, screened or further graded. Grain is best handled and stored in batches, separated by variety, TN, and grade. After thorough cleaning, drying and perhaps more extended storage the grain will receive a more thorough laboratory evaluation. These check procedures take days, compared for the checks carried out at grain intake, for which only a few minutes are available. Efforts are made to ensure that the grain does not carry unacceptable levels of residues of insecticides, fungicides, plant growth regulators, or herbicides by checking the grain's history with suppliers. Some grain samples will be sent to specialized laboratories to check residue levels.

2.2.2 Changes occurring in malting grain

Before malting, grain is screened and aspirated to remove large and small impurities and 'thin' corns. To initiate malting it is hydrated. This is achieved by 'steeping', immersing the grain in water or 'steep liquor'. Later, the moisture content may be increased by spraying or 'sprinkling' the grain. The steep-water temperature should be controlled. At

elevated temperatures water uptake is faster but microbial growth is accelerated and the grain may be damaged or killed. The best temperature for steeping immature (partly dormant) grain is low (about 12 °C, 53.6 °F). For less dormant grain a value of 16–18 °C (60.8–64.4 °F) is often used. As the grain hydrates it swells to 1.3–1.4 times its original volume. To prevent it packing tightly and wedging in the steep it may be loosened and mixed by blowing air into the base of the steeping vessel. This also adds oxygen to the steep liquor. The oxygen is rapidly taken up, both by the grain and by the microbes that multiply on the grain and in the liquor. Material is leached from the grain and enzymes from the microbes start to degrade the materials in the grain surface layers. Thus the liquor contains an increasing number of microbes, microbial metabolites and dissolved substances, it becomes yellow, gains a characteristic smell and may froth.

Some of the substances and the microbes in the liquor check grain germination. Infestations of microbes are undesirable. They compete with the grain for oxygen and reduce the percentage germination and germination vigour. Some produce plant growth regulators (including gibberellins) which stimulate or inhibit malting, others may produce mycotoxins which damage yeasts and/or are toxic to human beings. Some produce agents which cause beer to gush (over-foam), they produce some hydrolytic enzymes which may improve malt performance in the mash tun. Contamination with bacteria may give rise to worts and beers which are hazy with suspended, dead microbes (Schwarz *et al.*, 2002; Walker *et al.*, 1997).

Steep water, which checks grain germination and growth if re-used, is periodically drained from the grain and replaced with fresh. The minimum acceptable number of water changes are used since both the supply of fresh water and the disposal of steep effluent are costly. Sterilants are not routinely used in steeps, but many substances, including mineral acids, potassium and sodium hydroxides, potassium permanganate, sodium metabisulphite, slaked lime water and slurried calcium carbonate and formaldehyde, have been used, as has hydrogen peroxide. ‘Plug rinsing’ grain in the steep by washing downwards with a layer of fresh water, (with or without hydrogen peroxide or other substances), as the steep is drained is an economical possibility for removing suspended microbes, their nutrients and other substances (Briggs, 2002).

To control the microbes which produce mycotoxins and gushing-promoting agents it has been proposed that they should be swamped with ‘harmless’ microbes which will outgrow the problem-causing species. Species investigated include lactobacilli and strains of *Geotrichum* yeast (Boivin and Malanda, 1998; Haikara *et al.*, 1993; Laitila *et al.*, 1999). The results appear promising, but these microbes will also compete with the grain for oxygen. Their use might be combined with a washing procedure (Briggs, 2002).

Air rests are used between steeps. After a steep has been drained air, which should be humid and at the correct temperature, is sucked down through the grain. Such downward ventilation, or ‘CO₂ extraction’, assists drainage, provides the grain with oxygen, removes the growth-inhibiting carbon dioxide and removes some of the heat generated by the metabolizing grain. In consequence, and in contrast to traditional practice, barley leaving the steep has usually started to germinate. When the grain is immersed it is partly anaerobic, and it ferments, forming carbon dioxide and alcohol (ethanol), a proportion of which enters the steep liquor. Under such conditions the grain will not germinate. Under aerobic conditions fermentation is repressed and germination can occur. During immersions air may be blown into the base of a steep, providing some oxygen and lifting and mixing the grain.

The onset of germination is indicated by the appearance of the small, white ‘chit’, the root sheath (coleorhiza) that protrudes from the base of each germinated grain. At this

stage the grain is transferred to a germination vessel (or floor in older maltings) or, if it is in a steeping/germination vessel, the equipment will be set into the germination mode. The grain grows, producing a tuft of rootlets (culms) at the base of the grain and, less obviously, the coleoptile or 'acrosipire' grows along the dorsal side of the grain, beneath the husk. The extent of acrosipire growth, expressed as a proportion of the length of the grain, is used as an approximate guide to the advance of the malting process. Variations in acrosipire lengths indicate heterogeneity in growth. The living tissues respire and carbon dioxide and water are generated resulting in a loss of dry matter. The energy liberated supports growth and is liberated as heat.

Many hydrolytic enzymes, which are needed when malt is mashed, appear or increase in amount. Some of these catalyse the physical modification of the starchy endosperm. In the initial stages of germination these hydrolases are released from the scutellum. However, after a short lag the embryo releases gibberellin hormones (GA_1 and GA_3 , gibberellic acid). These diffuse along the grain triggering the formation of some enzymes in the aleurone layer and the release of these and other enzymes into the starchy endosperm. Here they join the enzymes from the embryo in catalysing modification. As germination progresses the starchy endosperm softens and becomes more easily 'rubbed out' between finger and thumb. When the malt has been dried the modified material is easily crushed and 'friable', and is easily roller-milled, in contrast to the tough barley. The stages of physical modification are the progressive degradation of the cell walls of the starchy endosperm, which involves the breakdown of the troublesome β -glucans and pentosans, followed by the partial degradation of the protein within the cells and the partial or locally complete breakdown of some of the starch granules, the small granules being attacked preferentially. The extent of breakdown is limited by the availability of water.

Modification begins beneath the entire 'face' of the scutellum. In a proportion of grains it advances more rapidly on the ventral side of the endosperm, adjacent to the sheaf cells, while in others it advances roughly parallel to the face of the scutellum (Briggs, 1998). When enzymes from the aleurone layer have been produced modification progresses more rapidly, particularly adjacent to the aleurone layer. Thus modification begins adjacent to the embryo and advances towards the apex as germination proceeds. In well-made malt only a small proportion of grains are undermodified, and contain large amounts of undegraded (unmodified) starchy endosperm tissue. The products of endosperm breakdown, sugars, amino acids, etc., together with materials from the aleurone layer (phosphate, metal ions, etc.), diffuse through the endosperm and a proportion support the metabolism of the living tissues, while the remainder accumulates.

The growth of the embryo is at first supported by its own reserve substances and later by soluble materials from the modifying starchy endosperm, so there is a net migration of materials into the embryo. The levels of soluble materials that accumulate are regulated by the balance between their rates of formation in the endosperm and their rates of utilization by the embryo. In the finished malt these materials may be estimated as the cold water extract, CWE, or the 'pre-formed solubles'. The accumulation, with time, of enzymes and the physical modification of the grain, permit the increasingly greater recovery of hot water extract up to a maximum value. When the acrospires have grown to about 3/4 to 7/8 the length of the grain the hot water extract, the cold water extract and the level of soluble nitrogenous substances cease to increase with increasing germination time, and the fine-coarse extract difference has almost stopped decreasing although friability is still increasing and the viscosity of grain extracts may still be declining.

Enzyme levels may or may not be increasing, depending on the malting conditions. Usually germination is terminated at this stage by kilning. Longer germination periods

waste malthouse capacity and result in extra malting losses. A correct dose of gibberellic acid, GA₃, which, when used, is usually applied at the end of steeping, accelerates the growth of the embryo but stimulates most of the processes of modification relatively more so that malt can be prepared more rapidly and in better yield. Where permitted the excessive accumulation of soluble nitrogenous substances that can occur in GA₃-treated grain may be limited by the application of sodium or potassium bromate, which inhibits the activity of some proteolytic enzymes. By checking the growth of rootlets this agent also increases malt yields.

The processes that occur in germination are regulated by controlling the moisture content of the grain, the quality of the grain and the temperature programme of the grain during steeping and the germination period. Nearly all malt is made using 'pneumatic' malting plant in which the grain is ventilated with a stream of humidified and temperature-adjusted air to remove excess heat and carbon dioxide and to supply oxygen. In the UK, limited amounts of high-quality malts are still made by traditional floor malting. From time to time the piece (batch) will be turned or stirred to separate the grains by untangling the rootlets and allowing the easier passage of the conditioning airflow.

Malting losses can be defined in several ways. If they are defined in terms of the losses in dry weight, which occur when cleaned barley entering the steep is recovered as kilned malt and has been de-culmed (dressed), then the losses sustained in making conventional malts are usually in the ranges: steeping losses, 0.5–1.5%; germination losses, 3.5–7.5%; rootlets, 2.5–5.0%. These divisions are artificial, since some respiration and growth occur in the steeping phase and in the initial stages of kilning. Rootlets are sold, usually for use in animal feeds, but the cash value is less than that of an equal weight of malt. Malting losses are larger when coloured malts are being produced. Modification of the green malt is likely to be more extensive if it is to be used in making darker malts. It will probably have been germinated with a relatively high moisture content and will be rich in soluble sugars and soluble nitrogenous compounds that will react during kilning to generate melanoidins, and so generates colours and characteristic flavours and aromas.

Most modern kilns hold a bed of grain about one metre deep, (which is not turned during kilning), through which a current of air is fan-driven from below. This air is heated either directly, using low-NO_x burners fuelled with oil or gas (which generate little or no oxides of nitrogen), or indirectly by heat exchangers. Oxides of nitrogen are avoided to prevent the formation of potentially harmful nitrosamines. When making pale malts the airflow is rapid and the 'air-on' temperature is low during the initial, drying phase. As the air rises through the bed of malt it becomes saturated with moisture and it is cooled by the need to provide energy to evaporate the water. So above the drying zone the air is saturated with moisture and the grain can continue to grow, generate enzymes and modify while being warm. In the initial stages the air-on temperature may be about 50°C (122°F), and the air-off temperature is around 25°C (77°F), which will be the temperature of all the green malt above the top of the drying zone. To economize with fuel this air should be passed through a heat exchanger to pre-heat incoming air. As the outgoing air is cooled moisture condenses on the tubes of the heat exchanger, liberating its heat of condensation, which is passed to the incoming air.

With the passage of time the drying zone extends upwards through the bed of malt until it reaches the surface of the grain bed. At this time, at the 'break point', the relative humidity of the 'air-off' falls and the temperature rises. When this occurs the airflow is reduced and the air-on temperature is increased to begin the curing (cooking) stage. As

the malt dries the temperature is progressively increased to the maximum, 'curing' temperature. As the fuel used in kilning is costly, the procedure is adjusted to save heat. During curing a progressively higher proportion of the air may be re-circulated. Alternatively the hot air may be diverted to a second, 'linked' kiln in which the malt is in the drying stage. Here it is mixed with more heated air to provide the large volume of air required during drying. Many pale malts are cured at about 80 °C (176 °F), but some will be 'finished' at higher temperatures, up to 105 °C (221 °F).

While enzyme destruction occurs at these elevated temperatures some enzymes survive provided that the malt has first been dried at low temperatures to a low moisture content. Under these conditions colour formation is minimized. In the manufacture of some coloured malts the temperature is increased while the grain is still comparatively wet to promote the formation of free sugars and amino acids and the interaction of these and other substances form the coloured melanoidins and flavoursome and aromatic substances. In these malts enzyme levels are comparatively low and, in extreme cases, enzyme destruction is complete.

Most special malts are now 'finished' in roasting drums. These metal cylinders may have capacities ranging from 0.5 t to 10 t. As they turn the contents are mixed by internal vanes and may be heated indirectly, by heating the outside of the drum, or directly, when hot air is passed through the interior of the cylinder, drying the contents. Depending on the malt being made a drum is loaded either with pale, kilned malt or green malt, and the processing is varied. The cylinder is heated while rotating and the contents are subjected to a carefully chosen temperature regime. The colour and physical state of the grain is frequently checked on samples. At exactly the correct time heating is stopped, in some instances water is sprayed into the cylinder, and the malt is withdrawn and cooled. Green malt is usually used in making crystal or caramel malts (which are not all dark in colour) while pale, kilned malts are used in making other types which vary in colour from amber to black (Briggs, 1998 and Sections 2.2.5, 2.2.6).

After kilning malts are dressed (de-culmed or de-rooted and cleaned). The cooled malt is agitated to break up the brittle rootlets and these, and dust, are separated by sieving and aspiration with air currents. Pale malts are usually stored for 4–6 weeks before use when, for unknown reasons, the brewing values often improve. Coloured and special malts should be brewed with as soon as possible, because during storage their special aromas (and perhaps flavours) decline. Malts are stored in ways intended to minimize the pickup of moisture, and to exclude birds, rats, mice and insects. It is important to prevent malts being mixed or being contaminated with un-malted barley during handling or storage. It is impossible to make successive batches of malt that have precisely the same analysis. Each batch should be stored separately and different batches should be blended so that the mixture meets the brewer's requirements. Different batches of malt made from one variety of barley, in the same way and intended to meet the same specification can be safely blended. Brewers take different views regarding what other blending is permissible. Specifications may stipulate that no other blending should occur, while others will accept blends of any varieties (even involving malts from two- and six-rowed barleys) provided that the analyses of the mixture are as stipulated.

Before dispatch the malt will be cleaned by screening, aspiration, passage over magnetic separators to remove fragments of iron, and (often) through a gravity separator/de-stoner. Usually malt is delivered in bulk, (often 25 t batches), but for export some batches will be packed in very large sacks (1 t capacity) which will be transported in containers. Some maltings will provide smaller breweries with malt in smaller sacks that are made with several layers of different materials and are strong and waterproof.

Rootlets are usually sold for cattle feed. However, they have been used to provide nutrients for microbial cultures and in making composts for growing mushrooms. Other markets are being sought. Because of their low bulk density, inconvenience in handling and a strong tendency to pick up moisture, rootlets are now usually pelletized, together with malt and grain dust and sometimes with thin grains. Rootlets (culms, coombes, cummins, malt sprouts) vary in their nature depending on what malt they came from and in particular how strongly they were kilned (Briggs, 1978,). Commonly analyses are in the ranges: non-protein extract, 35–50%; crude protein, 20–35%; ash, 6–8% and fibre, 9–15%. They are rich in low molecular weight nitrogenous substances and B vitamins.

2.2.3 Malting technology

Many types of malting plant are in use, but only the most common types will be described. Malting is comparatively safe, provided that certain precautions are observed. Some, sometimes unfamiliar, risks are due to carbon dioxide and to grain and malt dust. As grain is steeped and germinated it liberates carbon dioxide. This heavy gas can 'pool', so it is essential to check that vessels and confined spaces are ventilated before they are entered. Dust must be confined and cleaned away not only because it becomes damp and a breeding ground for insects and microbes, but also because when it is breathed it can cause allergies and fungal lung infections and it can form explosive mixtures when mixed with air. All handling equipment must be earthed (grounded) to prevent sparks, which might trigger an explosion, and all conveyors, ducts, etc., should have explosion vents.

Modern malt factories process large batches of grain, (often 200–300 t batches), and the process stages are highly automated so that processing conditions are reproducible and the manpower needed to produce each tonne of malt is minimized. In large maltings grain is delivered in bulk, by ship or barge or train or lorry. Before unloading begins the bulk should be inspected and sampled for analysis. When the quality has been agreed unloading begins. Grain is usually sucked from the holds of vessels, and this pneumatic system may be used to empty rail wagons or lorries, or these may be emptied under gravity. Lorries usually unload into an intake pit by tipping or from a hopper. The grain runs into the pit, which is ventilated to remove dust, and is equipped with a coarse moving screen (sieve) to catch and remove coarse impurities such as straw and large stones. Each lorry is weighed on to the site and off after unloading. The difference in weights gives the amount of grain unloaded.

During malting grain will be moved several times. The equipment used varies, but will usually include bucket elevators, helical screw conveyors (worms), belt conveyors and chain and flight conveyors. Less usually the grain will be moved using pneumatic conveyors. It is highly desirable that, to avoid cross-contamination, the equipment used to move grain is entirely separate from that used to move malt. The freshly delivered barley is conveyed to a 'green grain' bin for temporary storage. Here it will remain, usually being ventilated with fresh air, until it can be precleaned and, if necessary, dried. Precleaning involves rapid screening to remove gross impurities, such as sand, straw, stones and string, which are either appreciably larger or smaller than the grains, and aspiration with air to remove dust. The dust from this and other locations is trapped in cyclones and textile-sleeve filters. The grain also passes over magnetic separators, which retain iron and steel impurities.

In Northern Europe the grain usually needs to be dried (to 12% moisture, or less) before it can be safely stored. Drying and pre-cleaning may be carried out before the grain is delivered but, because of the risk of heat damage caused by inexpert drying, some

maltsters do not allow this. The drying temperatures used are lower for more moist grain, because wetter grain is more easily damaged by heat. Batch drying can be carried out in malt kilns or in steeping, germination and kilning units (vessels; SGKVs) or in dedicated batch driers. In these the grain rests on a perforated floor or deck and warm air is passed through it, e.g., for eight hours, until the grain has been dried sufficiently. The grain then may or may not be cooled, depending whether it is to be committed to long-term storage or it is to be stored warm for a short period to overcome dormancy (i.e. to hasten post-harvest maturation). In flow-through dryers the grain passes downwards under gravity in a stream that is regulated by valves. The grain passes through a series of zones in which it meets air at different temperatures and is successively warmed, dried and cooled. If there is to be a period of warm storage the cooling may be limited or omitted, so that the grain reaching store is at 30–40 °C (86–104 °F), rather than 15 °C (59 °F) or less, which is desirable for long-term storage.

The dried grain may now be thoroughly cleaned either immediately or after warm storage. This process is less rushed than pre-cleaning and so is more thorough. The grain is screened to remove thin corns and sometimes it is graded into size classes (e.g., above and below 2.5 mm width), which are malted separately. The screens used may be flat and oscillate horizontally or they may be rotating cylinders. At present the quality of the grain on delivery in the UK is so good that apart from aspiration, screening and passage over magnetic separators, this is all the cleaning required. However, with less clean samples it may be necessary to remove light impurities with air classification and foreign seeds and broken grains with Trieur cylinders or Carter-Simon disc separators (Briggs, 1998). The clean barley may be stored in flat-bed stores, bins or silos. If storage is to be for an extended period then the grain can be treated with an approved insecticide. If the grain is held relatively moist (> 12%) it will have to be ventilated. At a 12% moisture content grain can be stored for some months at or below 15 °C, but for periods over about six months a moisture content of 10% is safer. Stores must be regularly inspected for signs of insect infestation and fungal attack and depredations by birds or rodents. The temperature of the grain, determined by probes positioned at various sites and depths, should be recorded weekly and any undue increase acted on as a sign of deterioration.

Grain is weighed on its way to the steep(s). If abrasion (limited physical battering or rubbing the grains together) is to be employed this is carried out in advance of steeping as grain can be treated at rates of only 10–12 t/h and malting batch sizes are often as high as 300 t, and so this amount of treated grain must be accumulated before steeping can begin. Historically, steeps were barrels or shallow troughs in which grain rested, under water, at depths of 1–2 ft. (0.31–0.62 m). Numerous patterns of steeping vessels have been used. Those preferred now are either flat-bed or conical-bottomed steeps. Flat-bed steeps are circular in plan view, and the grain is supported on a perforated deck above the true base, so there is a plenum beneath the deck. For a 200 t batch size the steep might have a diameter of 15 m (49.2 ft.; Gibson, 1989). Initial depths (before the grain swells) may be 1.5–1.8 m (approx. 4.9–5.9 ft.). Grain is loaded in from above, dropping through sprays of water that quench the dust, falling into water. The bed is levelled with a rotating spreader, called a giracleur. Air may be blown in beneath the deck while the grain is immersed, and in dry periods air may be sucked down through the grain. The steeped grain is discharged through ports impelled by the giracleur. Such steeps allow relatively even grain treatment, since the bed depth is comparatively shallow, but the water used to fill the plenum is ‘waste’ and so effluent volumes are large. In addition it is difficult to keep the plenum chamber clean.

Newer maltings usually employ various types of conical-bottomed steeps. As each steep should contain less than 50 t, to avoid deep cones with excessively high pressures

on the grain in the cone base, a set of steeps is required for each batch of grain. Typically each steep consists of a vertical cylinder, closed below with a cone. Grain is loaded into each steep from above. The base of the cone contains a valve that retains the grain and water, a perforated zone through which the water can be drained while the grain is retained, an outlet through which air can be drawn during CO₂ extraction during air rests and inlets through which compressed air can be supplied when the grain is being aerated when under water. Such steeps are 'self-emptying'. The cone angle is sufficiently acute to ensure that when the valve is opened the grain falls out into a conveyor. This is one way of 'dry-casting' the grain. An alternative method is to 'wet-cast' the grain, pumping it to the germination compartment slurried in water. In steep-germination and steep-germination-kilning vessels (SGVs and SGKVs) no transfer is required. If additives, such as gibberellic acid and/or sodium bromate are to be added it is convenient and economic to spray on solutions as the grain is conveyed from the steep.

In floor malting the steeped grain is spread on a floor in a room having a cool, humid atmosphere. Germination is controlled by turning the 'piece' (batch) and thickening or thinning the layer of grain to allow temperature rises or falls as needed. Fine malts can be made in this way, but only in small quantities (ca. 10 t/batch) and with substantial manpower. Modern maltings are of the pneumatic type, in which the grain is turned mechanically and the grain temperature is controlled by forcing a stream of attemperated and water-saturated air through a bed of grain. Newer germination vessels are usually rectangular 'Saladin boxes' or circular compartments. In these vessels steeped grain is formed into a bed, usually 0.6–1.0 m (approx. 2.0–3.3 ft.) deep. The grain rests on a perforated deck, through which the conditioning airflow is driven. Some of the air is recirculated and mixed with fresh air. The air is driven by a fan and is usually humidified by passage through sprays of water. Air temperature may be controlled, by regulating the water temperature, sometimes augmented with heating or cooling by heat exchangers. The grain lifted and partly mixed, and the rootlets are separated by passing a row of vertical, contra-rotating helical screws through the bed. The bed is 'lightened' and the resistance to the airflow is reduced. Bed temperatures of 15–19 °C (59–66.2 °F) are common, with temperature differentials between the top and bottom of the bed of 2–3 °C (3.6–5.4 °F). The turner arrays are usually fitted with sprays to allow the grain to be moistened.

In some plants the grain is first germinated in a circular, stainless-steel lined vessel, then it is transferred to a germination and kilning unit (or vessel; GKV). When germination is sufficiently advanced the cool airflow, which may or may not be humidified, is discontinued and hot air is supplied from a furnace or heat exchanger. In old kilns the malt was dried in thin layers and with periodic turning. In modern kilns the grain beds are relatively deep and are not turned. The kilns may be directly or indirectly heated. They are instrumented so that correct temperature differentials are maintained between the air-on and the air-off and that at the break point the airflow is reduced and subsequent air re-circulation, temperatures and flow rates are correct. As noted before, heat should be conserved by 'linking' kilns and/or using heat exchangers. Further heat can be recovered from the outgoing air by using a heat pump, but at present this is not economic because the capital and maintenance costs are high.

2.2.4 Malt analyses

Malt analyses are carried out according to one of the several sets of agreed methods (Section 1.15.1, p. 9). As with barley, analysis of a malt lot is useless unless the samples used are properly drawn and handled. Because of differences between the methods, both

in the conditions and calculations used, the results obtained often differ, both in the values obtained and the ways in which the results are expressed. Some of the most important methods will be discussed. Others are considered elsewhere (Briggs, 1987; 1998). The moisture contents of malts are usually in the range 1.5–6%, expressed on a fresh weight (fr. wt.; as is) basis. Primary analyses are by oven-drying methods, but NIR (near infra-red) analysis is the usual, more rapid, secondary method. Brewers normally specify an upper moisture limit. Because malt is hygroscopic it will normally have a lower value when dispatched, to allow for moisture uptake while in transit. Brewers use malt ‘as is’, and so they pay attention to the extract of the undried malt. However, for comparative purposes extracts are mostly given on a dry weight basis (on dry). A malt sample must not contain more than a certain percentage of thin corns, because thin corns are not broken up in mills with rollers set relatively far apart to achieve a coarse grist. When malt is hammer milled this consideration does not apply. Cold water extracts (CWE) are used by some ale brewers. The value of this determination is disputed. The grain is ground and extracted at 20 °C (68 °F) with water made alkaline with ammonia (to inactivate enzymes). The specific gravity of the extract is a measure of the ‘preformed soluble substances’ present in the malt. Departure from customary values warns that the malt lot is different from its predecessors.

The hot water extract or extract (HWE or E) value is the single most important measurement in judging malt quality. The HWE method used by the IoB was designed for use by traditional ale brewers, and involves an isothermal laboratory mash (65 °C; 149 °F) made with distilled water and a comparatively coarsely ground grist. After one hour the mash is cooled and adjusted to either a volume of 515 ml or to a weight of 450 g and the specific gravity of the liquid, obtained by filtration, is measured at 20 °C (68 °F). Using the appropriate formula the extract is calculated from the excess specific gravity (i.e., the gravity \times 1000 above water, taken as 1000.00 at 20 °C (68 °F)) as litre-degrees/kg malt (l°/kg). Sometimes the HWE of a finely ground grist is also determined. Extract is obtained in greater yields from finely ground malt and the smaller the fine-coarse (f.-c.) extract difference the better the malt is modified. Because this value is the difference between two large numbers and is small relative to the errors involved in measuring the extracts, the determination must be replicated to obtain a reliable value, which is laborious. Another ‘non-standard’ proposal is to use the difference in extract yield from a fine grind mash and a concentrated, very coarse grind mash. This ‘f.-c. conc.-extract difference’ method gives larger differences than the f.-c. grind method and appears to be an improvement on it, the values obtained being inversely related to extract recoveries in a brewery (Bourne and Wheeler, 1982; Briggs, 1998).

The determination of extract, E, by the EBC and the very similar ASBC methods differs considerably from the IoB method. They were developed for traditional lager brewers but the temperature programme used does not resemble that of most old lager breweries or that of breweries which employ temperature programmed mashing. In the EBC method finely ground malt is mashed in at a low temperature (45 °C; 113 °F), with continuous stirring. The temperature is then increased, at 1 °C (1.8 °F)/min., until it reaches 70 °C (158 °F). This temperature is now maintained and more water, also at 70 °C, is added. After one hour, during which the ‘saccharification time’ is determined (see page 24), the mash is cooled and adjusted to 450 g. The specific gravity of the wort is determined. Using tables that relate the strengths of sucrose solutions with their specific gravities, the weight of extract in the laboratory wort is calculated, assuming that the dissolved extract solids change the specific gravity to the same extent as sucrose. The EBC method uses Plato’s tables while the ASBC method uses Balling’s tables

(Appendix). The extract of the malt is expressed as a percentage (%). This calculation makes some unwarranted assumptions, so the values are unreliable in absolute terms, but it gives useful relative values. There are no conversion factors that allow the calculation of extracts determined by one method to be accurately expressed as the extracts determined by another method, even though the results are roughly correlated. Extracts of pale malts determined by the EBC method are usually in the range 77–83%, (on dry), while values for the IoB method are usually 300–310 l°/kg (on dry). Similarly the typical ranges for darker, malts are 75–78% and 255–285 l°/kg respectively. Sorghum malts, which are used to make pale lager-style beers in tropical Africa as well as opaque African-style beers, are not reliably analysed by the extract determination methods developed for barley malts, because the gelatinization temperature of sorghum starch is higher than that of barley (see Table 2.3 on page 38).

Various special, but apparently unstandardized, analytical mashing programmes are in use (Briggs, 1998). The laboratory mashes differ from brewery mashes in a number of important ways. Unlike brewery mashing liquor the water used is distilled and contains no salts, nor is the mash pH adjusted. Also the grist is prepared by using mills that work differently from brewery mills. The laboratory mashes are dilute compared to brewery mashes and at the end of mashing the grist is not sparged with hot water. Several attempts have been made to devise more 'brewery-like' laboratory mashes, but they have not been accepted. Each brewer discovers the relationship between a malt's 'lab. extract' and the extract recovered from this malt in the brewery. The extract determinations described apply to pale malts. Different methods are necessary for special, highly coloured malts that lack enzymes. For example a 50:50 mix of a coloured malt with an enzyme-rich pale malt may be mashed and the extract of the coloured malt is calculated, making the assumption that the pale malt gives half of the extract it yields when mashed alone.

More information is gained from analysing the mash and laboratory worts. The rate of wort filtration from a laboratory mash does not give a good indication of the brewery wort run off. 'Mashing columns' are needed to achieve this, and these devices are not suitable for routine analyses (e.g., Webster, 1981). Wort colours are determined in different ways, either visually with colour comparators, or at a single wavelength, or at three different wavelengths (the tri-stimulus method, Chapter 19) using a spectrophotometer. All these approaches have limitations since extracts from different malts not only differ in colour intensity but also in their spectral characteristics. Because worts darken to various extents during the hop-boil it is sometimes desirable to measure the colours of boiled laboratory worts. One problem with the IoB methods is that the wort from the 450 g mash is more concentrated, and therefore more deeply coloured, than that from the 515 ml mash, and so the mashing method employed must be stated when results are given.

The pH of wort is often routinely recorded. The values obtained vary with the type of malt. Unusually acid wort (low pH) can be caused by a heavy infestation of microbes on the malt (Stars *et al.*, 1993).

Malts are analysed for their nitrogen ('protein') contents and the laboratory worts are also analysed for dissolved nitrogenous materials. The values are expressed as nitrogen, N, in the IoB methods and as 'protein' (crude protein = $6.25 \times N$) in the EBC and ASBC methods. Because of the differences in the mashing conditions the last two mashes generally give more soluble nitrogen in the worts than the IoB method. Brewers are concerned that a malt has a total nitrogen (TN; 'protein') content in the specified range since, outside this range, the wort obtained may differ significantly in quality and there may be problems with extract recovery.

Total soluble nitrogen (TSN) and free amino nitrogen (FAN) values are determined. The TSN needs to be sufficiently high so that the 'body' and mouth-feel of the beer is adequate, and the beer foam (or 'head') will be stable. The soluble nitrogen ratio (SNR; TSN/TN) of the malt (or the soluble protein ratio or Kolbach Index of the ASBC and EBC methods (in each case soluble protein/total protein) serve as measures of modification and a value is often included in malt specifications. FAN values (chiefly amino acids and small peptides) must be sufficiently high to ensure that lack of nitrogenous yeast nutrients does not limit fermentation. FAN has been determined by different methods, which gave different results, so it is essential that the method used is specified.

Previously, nitrogenous yeast nutrients were assayed as 'formol-nitrogen'. Over the years the preferred nitrogen contents for British pale ale malts have risen from around 1.3–1.45% to around 1.65%. Perhaps this is due in part to newer varieties of barley and changed brewing practices. For enzyme-rich malts, needed with high-adjunct brews as in some North American breweries, TN values of 2.2% (13.8% protein) or more may be preferred. In the past, other measures were made such as permanently soluble nitrogen (PSN) and coagulable nitrogen, respectively the nitrogen in the substances remaining in the wort and those precipitated when the wort was boiled. This method has fallen out of use.

In EBC analysis the time in minutes taken after the mash has reached 70 °C (158 °F) for samples to stop giving a positive iodine test for starch is recorded as the 'saccharification time'. This is really a rough measure of the time taken for the starch to be dextrinized, and is largely dependent on the α -amylase content of the malt. The odour of the mash is noted as, less usually, is the flavour. Both should be normal for the type of malt being analysed. The appearance of the wort is noted, whether it is clear, opalescent or turbid. The activity of the mixture of the starch-degrading enzymes in malt is estimated as the 'diastatic power', or DP. The enzymes are collectively referred to as diastase. In principle, soluble starch is incubated with a malt extract and the degree of starch breakdown is estimated after a period of incubation at a controlled temperature. The results are not highly reproducible and represent the joint activities of several enzymes that are present in different proportions in different malts. Results are expressed in different units including °L (degrees Lintner) and °W-K (Windisch-Kolbach units). The values indicate to brewers if the enzyme content of a malt is adequate.

The level of α -amylase in malt extracts is determined by one of several methods. The level of activity of this enzyme must be adequate if the starch from adjuncts is to be liquefied in a mash. The ratio of fermentable to non-fermentable sugars is largely regulated by the activities of the diastatic enzymes during mashing. The fermentabilities of worts should be constant when brewing a particular beer. Analytically the fermentabilities of the HWE or E worts may be determined. However, the fermentability of these worts increases with storage time as malt enzymes that have survived the mashing process continue to break down dextrans to simpler, fermentable sugars. Thus laboratory wort should be boiled to inactivate the enzymes (as occurs in the hop-boil). Then it is inoculated with a pure yeast and it is incubated under anaerobic conditions until fermentation is complete. The fall in the specific gravity of the wort allows the calculation of the attenuation limit of the wort and its fermentability (Chapter 4).

When malts contain substantial levels of β -glucans modification is incomplete and the polysaccharide itself may cause problems in the brewhouse. The β -glucans may be assayed using methods based on enzymes degrading them to glucose, which is measured, or by the fluorescence of the complex between the polysaccharide and the reagent Calcofluor. The activity of the enzymes in malt that degrade β -glucans, the β -

glucanases, are measured either by following the decline in viscosity of a solution of β -glucan incubated with an extract of malt containing the enzyme, or by following the breakdown of an artificial substrate, a colour-labelled β -glucan. Under some circumstances it is desirable that malts should contain adequate levels of this enzyme, which is readily inactivated when green malt is kilned using any except the lowest temperatures. Other substances that may be estimated include the dimethyl sulphide precursor (DMS-P), which is S-methyl methionine (SMM), and N-nitrosodimethylamine (NDMA). Different styles of beer require different amounts of dimethyl sulphide in the final product. As the precursor can be destroyed during kilning it is important that its levels are regulated. NDMA, and other less volatile nitrosamines, are suspected of being carcinogens. When discovered, high levels of NDMA were found in malts, particularly those from directly fired kilns. However the precautions now taken ensure that the amounts present are usually below the levels of detection. The levels of NDMA are still monitored.

The growth of acrospires roughly parallels the advance of modification in malting grains. The evaluation of acrospire growth in grains in a sample of malt can indicate that a malt has been made with irregularly germinated material or that good and less good malts have been mixed. In North American practice the acrospire lengths of corns in a sample of malt are classified, by length relative to corn length, as 0–0.25, 0.25–0.50, 0.50–0.75, 0.75–1.0 and over 1. Grains in which the acrospire has grown out from beneath the husk, i.e., over 1.0 in length (so-called overgrown corns, huzzars, cockspurs or bolters) are undesirable in most kinds of malt as they are deficient in extract. However, overgrown malts may be relatively rich in enzymes. Specifications may call for 86–95% of acrospires to fall in the 0.75–1.0 category and less than 5% to be overgrown (1+).

The physical modification of malt grains is traditionally assessed by crushing a series of corns between finger and thumb. Well-modified grains crush to a powder while the presence of 'hard ends' indicates that the apices are not modified and completely hard grains are unmodified. A number of other methods have been used. In the traditional 'sinker test' a handful of malt corns is thrown into water. Barley corns sink, fully modified malt corns float horizontally and partly modified corns float with the apical ends downwards. This test is unreliable. The resistance of malt corns to grinding has been measured, as has the resistance of corns to cutting or penetration by blunt needles.

A device that has achieved wide acceptance is the Friabilimeter. In this a 50 g sample of malt is broken up between a rotating wire sieve and a spring-loaded roller. The friable material and the husk fragments escape through the sieve, and the material remaining after a set period is weighed. The friability is the percentage (by weight) of material that passes through the sieve. Investigation of material remaining on the sieve can be informative and can indicate if the malt corns generally contain unmodified material or if a substantial proportion of wholly unmodified grains is present. From this an estimate of the homogeneity of the malt can be made. Other approaches give indications of the patterns of modification that have occurred. Samples of malt are stuck to a flat support and a proportion of the grains is ground away with a mechanical sander. In one method the exposed grain interiors are treated to suppress autofluorescence and then they are treated with Calcofluor. Under UV light this fluoresces when associated with the β -glucans in the unmodified regions of the endosperm cell walls but there is no fluorescence in the modified regions. Thus the percentage area modified in each exposed area of endosperm can be assessed, preferably with a specialized automatic scanner. In the other method about 0.25% of the grains is sanded away and then they are exposed to

an alcoholic solution of the dye methylene blue. This penetrates only into the modified regions of the grain. The stained grains are dried and are sanded further. The blue regions of the endosperm are modified and the white regions are not. Again, the relative areas modified can be estimated. This data allows the degree of modification and its heterogeneity to be estimated.

The values for 'nitrogen modification' (SNR; Kolbach Index) do not always parallel the estimates of physical modification, and indeed the relationships between the two can differ to an important extent when different varieties of barley are malted in parallel. Brewers do not want undermodified or overmodified malt. With undermodified malts extract recoveries in the brewery are unduly low, wort separation can be slow, the worts obtained may be cloudy, the hot break may form poorly, the wort may have a low fermentability and ferment slowly, the beer may be difficult to filter and the filters may become blocked quickly causing high pressures to build up and giving short filtration runs. Finally the beers may quickly become hazy. In extreme cases β -glucan gels may form and deposit. On the other hand overmodified malts have their disadvantages. Malt breakage and losses (as dust) are high and wort separation may be slowed by the large proportion of fine particles in the grist. Head retention may be poor, and yeast growth can be wastefully excessive. The hot and cold breaks may be heavy, the wort may contain finely divided material that is hard to remove by filtration and, because of the excessive levels of reducing sugars and amino acids present, the wort may darken too much on boiling, due to the formation of melanoidins.

From time to time other analyses may be performed. Thus levels of arsenic, lead, cadmium and iron may be determined to check for the absence of contamination. Zinc can be measured but, as there is no clear relationship between this and the amount of zinc available to the yeast in the wort, this is rarely done. Levels of microbes, especially *Fusaria*, may be determined and several tests for agents causing gushing have been devised (Donhauser *et al.*, 1991; Vaag *et al.*, 1993). Sometimes samples may be analysed for halogenated contaminants (such as chlorinated substances), or residues of insecticides or agricultural chemicals. Where the use of added gibberellic acid is forbidden residues of this substance may be sought on the malt's surface. As this substance occurs naturally within the grains the results of such tests must be suspect.

2.2.5 Types of kilned malt

Malt types are not clearly distinct. The descriptions given here are representative. Different breweries specify distinctly different malts giving them the same title ('pale lager', mild, ale, etc.). The question of what constitutes a sensible malt specification is discussed later. Extensive sets of malt analyses are available (Briggs, 1998; Narziss, 1976; 1991). In this chapter malts are described with emphasis on the aspects most of interest to brewers. Where the use of adjuncts is forbidden, as by the German *Reinheitsgebot*, chit malts and short grown malts may be used. These are less expensive to produce than 'normal' malts. They retain some raw grain characteristics and have some of the advantages that are gained from using unmalted grains as adjuncts. These malts are made by steeping barley to a low moisture content and then, either as soon as the grain has chitted or after a short period of germination, the 'green malt' is dried at a low temperature. The malting losses occurring in making these materials are small and, because of their low moisture contents, they are comparatively inexpensive to kiln. The products have moisture contents of 2–5% and contain some hydrolytic enzymes but the endosperms are incompletely modified. Their Kolbach indices are low and extracts may

be 77–80% (on dry, EBC) with fine-coarse extract differences of 6–12%. These malts provide less expensive extract and better beer foam stability than conventional malts, but they enhance wort and beer viscosity, slow wort separation and reduce the rate of beer filtration and the length of filter runs. Short grown green malts have been flaked before use, without being kilned, which facilitates extract recovery but destroys the enzymes originally present.

Kilning is expensive, so attempts have been made to brew with green, unkilned malt. This material is unstable and must be used as soon as it is ready. It is exceptionally rich in enzymes and yields highly fermentable, proanthocyanidin-poor wort with a good extract. Its high content of hydrolytic enzymes allow it to convert a high proportion of adjuncts in mashes (Briggs *et al.*, 1981). This material has rarely been used both because of its instability and because it imparts unpleasant flavours in the finished beers. Roots remain attached to green malts. A compromise would be to have malts dried at a low temperature to 7–8% moisture. Roots can be removed from such material, which can be stored for some weeks. It contains high levels of hydrolytic enzymes and, because less intensive drying is needed on the kiln, is less expensive to produce than normally kilned malt. Such material seems not to give unwanted flavours to beers. Despite these advantages such malt is apparently not in use.

Lager beers are widely produced, and all malts making these beers are, by definition, lager malts. In Germany, where most beers are lagers, the palest to the darkest malts are lager malts. In the UK lager malts and lager beers are all pale. In North America the lager-style beers are usually brewed using high levels of unmalted adjuncts in the mash and so the malts used differ significantly from European lager malts. The characteristics of European lager malts have changed during the last century, and the differences between British pale ale malts and lager malts have become indistinct. North American malts may be made from two- or six-row barleys or mixtures of both. In general their nitrogen contents are high (TN 1.7–2.3%; 10.6–14.4% protein), with soluble to total protein ratios of 43–48% and high levels of FAN, and hydrolytic enzymes (DU values of 30–45 or even 50 for α -amylase), all characteristics needed with adjunct-rich mashes. The high nitrogen contents are associated with lower extracts (77–81% on dry) but this is of less significance when so much of the extract is derived from adjuncts. Such malts are pale (1.4–1.9°Lovibond) and have moisture contents of 3.7–4.3%.

The palest of the European products are Pilsen malts (*Pilsener Malz*). In the past these were undermodified but now they are fully modified and are prepared from barleys having moderate nitrogen contents. They are kilned at low temperatures to minimize colour formation. Typical analyses are E, at least 81% (EBC, on dry), fine-coarse extract difference 1–2%; TN, 1.68 (10.5% protein); Kolbach index 38–42%; moisture less than 4.5%; α -amylase 40 DU; DP 240–300 °W.-K.; saccharification time 10–15 min.; colour, 2.5–3.4°EBC; boiled wort colour, 4.2–6.2°EBC; wort pH, 5.9–6.0. Helles (pale; light) malts are rather similar, but are made from barleys richer in nitrogen. British lager malts are all pale and well modified. Analyses are usually in the ranges: HWE 300–310 l/kg (on dry), TN, 1.55–1.75%; TSN, 0.5–0.7%; SNR, 31–41%; DP, not more than 70°IoB; moisture less than 4.5%; saccharification time less than 15 minutes. Colour may be 3.0°EBC. Because of the low temperatures used in kilning lager malts (finishing curing at e.g., 70 °C; 158 °F) are rich in enzymes and so sometimes give slightly higher extracts than pale ale malts, which are cured at higher temperatures (finishing at 95–105 °C; 203–221 °F), and have more characteristic flavours but lower enzyme activities.

In the last 50–60 years the moisture contents of the best pale ale malts have been allowed to rise from 1.5% to a maximum of 3% and preferred TN values have increased

from as little as 1.35% to around 1.65%. Other preferred current analyses are: HWE, 306–310 l/kg (on dry); TN from less than 1.55% to less than 1.70%; TSN, 0.5–0.7%; SNR, 31–42%; FAN, 0.1–0.12%; CWE, 18–22%, colour 4–6 °EBC; and DP, 44–65 °IoB. The malt will have a high friability. Many ale and lager malts are made to meet customers' particular specifications. However, it is more economical for maltsters to make larger volumes of 'standard' malt having specifications close to those of many of their customers and offer these at lower prices. The 'standard malts' from different suppliers have different specifications and these are likely to change when barley quality changes. Mild ale malts are generally made from lower-quality barleys and will be slightly less well modified and will be more strongly coloured than pale ale malts. A representative mild malt might have a HWE of 305 l/kg (on dry), and a fine-coarse extract difference of about 5 l/kg; a moisture content of 3.5%; CWE, 18–21%; TN, 1.55–1.75%; TSN, 0.6–0.7%; SNR, 36–40%. DP, 40–60; colour, 6–9 °EBC. Thus in UK malts the colours increase as one progresses from lager to pale ale to mild.

In German practice the next type is Viennese malt (*Wiener Malz*), which is used for making 'golden' lagers. This is made from normally modified green malt kilned to a final temperature of about 90 °C (194 °F), giving a colour of 5.5–6.0 °EBC. Munich malt (*Münchener Malz*) is relatively dark, very well modified and aromatic and is made by germinating nitrogen-rich barley, steeped to a high moisture content, so that it is well grown (all acrospires at least three-quarters grown) and finishing germination warm, at 25 °C (77 °F). Kilning involves some stewing and curing is finished at 100–105 °C (212–221 °F), conditions causing appreciable enzyme destruction. This malt has a colour of 15–25 °EBC. The wort is rich in melanoidin precursors and darkens on boiling, e.g., from 15 to 25 °EBC. Other typical analyses are: E, 80%, (on dry); fine-coarse extract difference 2–3%; total protein 11.5% (TN, 1.84%); Kolbach index, 38–40%; saccharification time, 20–30 min.; wort fermentability, about 75% (compared to wort from Pilsen malt of about 81%). α -Amylase and DP values are low, at 30 DU and 140 °W.-K. respectively. Analyses of a British made, Munich-style malt are: HWE, 300 l/kg, (on dry); moisture 4.5%; TN, less than 1.65%, TSN less than 0.65%, colour about 15 °EBC and DP at least 30 °IoB.

Brumalt (*Brühmalz*) is an even darker German malt, which is made by steeping a nitrogen-rich barley (e.g., TN 1.84%; protein 11.5%) and germinating it at an exceptionally high moisture content, about 48%. When the grain is well grown it is held in a closed container for, say, 36 hours so that the oxygen is used up and carbon dioxide accumulates. The temperature rises to 40–50 °C (104–122 °F) and the grain contents soften and become pulpy and rich in reducing sugars and amino acids. These melanoidin precursors interact when the green malt is kilned, at 80–90 °C (176–194 °F), to give a highly aromatic and melanoidin-rich material with a high colour, usually of 30–40 °EBC. Such malt gives characteristic rich flavours to beers and these are said to be stabilized by the reductones from the malt. Sometimes this general kind of material is called rH malt or melanoidin malt.

Some malts are made from barleys lacking proanthocyanidins (anthocyanogens; Briggs, 1998; Sole, 2000). The absence of the polyphenolic haze precursors means that beers made from these malts and using polyphenol-free hop extracts are unlikely to become hazy. Other 'conventional' malts are in use. Some special beers are brewed using a proportion of smoked malt (*Rauch Malz*) to gain a 'smoky' flavour, but these contain elevated levels of NDMA. Such flavours were once common, when malts were all kilned using direct-fired, wood-burning kilns. Now the smoke from a wood-burning furnace is led into the hot stream of air entering the bed of green malt on the kiln.

Acid- or lactic-malts have been used sporadically in the UK and more frequently in Germany to adjust the mash pH. Originally they were used to offset the effects of bicarbonate-rich mashing liquor. These malts carry 2–4% of non-volatile lactic acid. They are made in several different ways, for example by steeping or spraying green malt with solutions of biologically prepared lactic acid during germination and before kilning. Application of lactic acid to germinating green malt can check rootlet growth and the rise in malting losses and favour the accumulation of soluble nitrogenous substances. In another system pale malt is steeped in water at 45–47°C (113–116.6°F) for an extended period. Sugars are leached into solution and thermophilic lactic acid bacteria convert much of them to lactic acid. The grain is re-dried, and the acidic steeping water is re-used. The use of such malts (as 5–10% of the grist) lowers mash pH and, at least with some of these malts, the CWE is increased as is the HWE, the TSN and the FAN. A typical analysis (IoB) is HWE, over 297 l/kg (on dry); moisture, 5–6%; TSN, 0.8–1.2%; colour, 10–25°EBC; lactic acid, 2.1–2.5%. Such malts are often used where the addition of chemically prepared acids for pH adjustment is forbidden.

Some brewers prefer to add lactic acid, prepared biologically from wort (using *Lactobacillus delbrückii*), for mash pH adjustment. Various other materials have been added to malts. For example, added formaldehyde was not readily detectable, but beers made from such malt were low in proanthocyanidins and unlikely to form non-biological haze. In the Belmalt process green malt was sprayed with a solution of glucose syrup (3.5 kg/100 kg original barley) some hours before kilning. The malts were more acid and gave higher extracts and levels of soluble nitrogen than controls and the worts had higher attenuation limits. Residual glucose would account for the higher extract and fermentability and the conversion of some of the glucose to lactic acid by bacteria on the grain would cause mash acidification and so increase the TSN. Gum arabic has been sprayed onto malts to increase the head retention of beers made from them. Solutions of thermostable enzymes, probably including amylase and β -glucanase, have been applied to malts, presumably to enhance their apparent quality. These enzymes will not penetrate into the interiors of grains and so must exert their effects when carried forward into the mash. Generally it is better for brewers to keep these kinds of additions under their own control and make them at mashing or later in brewing.

Malts are made from cereals other than barley (Briggs, 1998; Byrne *et al.*, 1993; Narziss, 1976; Taylor and Boxall, 1999). Wheat malts are generally pale, although dark wheat malts are 'made to order'. In mainland Europe wheat malts make up the major parts of the grists (up to 80%) of special beers, including the German top-fermented *Weissbier* (white beer) and *Weizenbier* (wheat beer). In the UK small amounts of wheat malt (3–10%) may be included in grists to improve the foam formation and head retention of the beers. Other benefits claimed are improved beer clarity and palate-fullness. The flavour of wheat extract is relatively 'neutral'. Wheat malts tend to be undermodified and their inclusion in the mash can lead to slower wort run off and sometimes fining problems in beers. Wheat has a naked grain, so it is easily damaged during handling and the acrospire (coleoptile) is not protected by a husk during germination. Water uptake is rapid during steeping. Usually soft wheats (TN less than 1.9%) are malted and, like barley, they will respond to applications of gibberellic acid. Because of the absence of husk, which yields no extract, extracts of wheat malts can be relatively high, e.g., 328 l/kg (on dry), 86%. Wheat malts may have moisture contents of 5%, colours of 2–6°EBC; a TN of 1.87%, an SNR of 38–40%, a Kolbach index of up to or over 50%, and high levels of diastatic enzymes. Rye varieties have thin, naked grains and the malts made from them can confer unusual flavours (toffee, caramel) to beers,

with changes to the mouth-feel (palate; smoother; more mellow) and a slight improvement in head retention. Rye malt may give a red tinge to beer. Rye varieties differ greatly in their suitability for making malts. Compared to barley the thin, naked grain takes up water quickly. Pale rye malts (2–8°EBC) have exceptionally high but variable extracts (about 315 l°/kg, on dry, even 85–90% EBC) and very varied nitrogen contents (1.2–2.3%) and varied levels of diastatic enzymes. The malts are only occasionally used in special beers.

Malts have been made from the ‘synthetic’ wheat-rye hybrid triticale (*Triticosecale*) which, like its parents, has naked grains and takes up water rapidly during steeping. There are wide varietal differences in the malting quality of triticale cultivars. Although extracts can be very high (values of 335 l°/kg, (on dry) and 88–90% EBC have been reported) yet triticale malts are not used, possibly because the grain has a tendency to have high TN values and the malts yield hazy worts rich in soluble nitrogen, including suspended and finely divided protein largely derived from prolamines. The worts are very viscous because of dissolved pentosans (Blanchflower and Briggs, 1991; Byrne *et al.*, 1993). When milled, triticale malts give rise to a fine flour which impedes wort separation. In the past, stouts were made with high proportions of oat malts in the grists. The reasons for using oat malts are not clear and fermentation problems (foaming fermentations and cloudy worts) were often encountered. However, the high husk content of oats meant that the ‘husky’ grist favoured wort run off at the end of mashing. Small amounts of oat malts are now used to give character to special beers (toasted, biscuit-like aroma and an intense mouth-feel). The malts have some unusual characteristics. Extracts are low (e.g., 230–234 l°/kg on dry), the lipid content of the malts is high with the danger of the material becoming rancid and the beer having poor head retention and flavour instability. The TN value may be moderate (e.g., 1.6%), and the SNR is low (e.g., 18%). Diastatic power may be about the same as that of a barley malt having a similar nitrogen content.

Although malts are made from several tropical cereals only those made from sorghums have attracted much attention. In places in Africa millets have been malted mixed with sorghum grain, probably for the extra starch degrading enzymes provided by the malted millet (Chapter 16). Sorghum grain is steeped and watered during germination. Often the grain is treated with substances such as formaldehyde or sodium hydroxide in attempts to control the surface microbes. Relative to barley, sorghum is malted warm (e.g., 25 °C; 77 °F). The rootlets and the shoots are removed from the dried malt when lager-style beer is being made but not when the malt is for making opaque beer. The seedling tissues are rich in hydrogen cyanide. The information available on malted sorghum is inconsistent. This is probably because malted sorghum is used in making opaque beers (Chapter 16) as well as lagers and the requirements for these processes are different because of the large differences between different varieties of sorghum and because the methods of analysis and mashing that are applicable to barley malts are not all suitable for sorghum malts. This is primarily because the gelatinization temperatures of sorghum starches are higher than the starches of barley or wheat malts. Thus the extract of a sorghum malt determined using an inappropriate method (mashing at 65 °C; 149 °F) was found to be 112 l°/kg while mashing in an appropriate way gave an extract of 268 l°/kg. Elsewhere extracts from sorghum malts of between 65 and 85% were found, with fine-coarse extract differences in the range 0.5–18.2%. Estimates of other analyses also varied widely. It has been generally accepted that sorghum malts are deficient in enzymes (this is not a problem when making traditional, opaque beers), but this may not be true for malts made from some varieties.

2.2.6 Special malts

The malts already described are all 'finished' on kilns. However, there is a group of malts which are finished in roasting drums (Bemment, 1985; Briggs, 1998; Gretenhardt, 1997; Maule, 1998; Narziss, 1976). All these special malts are used as small proportions of grists to give particular colours, flavours and aromas (i.e., to impart characters) to beers. They can be considered in two groups; those that are prepared by a simple heating process, such as amber, diamber, brown, chocolate and black malts (and, by tradition in the UK, roasted barley), and crystal and caramel malts in which the wet malts are 'stewed' so that the endosperm contents are liquefied before they are dried and cooked. In each group a wide range of colours occurs. As the colour ranges are continuous and as the qualities of the starting materials can be varied as, to some extent, can the roasting regimes, it follows that the number of malts that might be made is unlimited. The more usual types and divisions are described here, but intermediate types can be made and sometimes are. Because these malts are required primarily for the characters and colours that they provide, extract and colour are the analyses which, together with moisture content, are usually specified. Sometimes coloured malts are made from wheat or other cereals but only the barley malts are in common use. Unlike 'white' malts, coloured malts should be used as fresh as possible, storage time being minimized, to retain their aromas. During their preparation the heating is so intense that no enzymes survive. As the colour increases in a series of malts so the malt extracts decline slightly as the extra colour is generated by more extreme or more prolonged heating. For example, in a series of German caramel malts the extracts and colours were: *Carapils*, E 78%, colour, 2–5°EBC; *Carahell*, E 77%, colour 20–25°EBC; *Caramünch*, E 76%, colour 50–300°EBC. As the colour increases so the wort pH values tend to decrease and the Kolbach indices decline.

Amber malts are prepared by roasting pale ale or mild malts or, after drying, well modified green malts. Heating programmes begin at about 48°C (118.4°F) and rise to about 170°C (338°F). The 'normal' colour range varies, but is usually 40–85°EBC. Moisture contents are 3.5% or less. Extracts vary between 270 and 285 l/kg. These malts are valued for giving characteristic dry palates and baked or biscuit-like flavours to golden-coloured ales. Diamber malts are probably not made now, but modern brown malts are similar to amber malts prepared at higher temperatures. Such malts may have extracts of 260–280 l/kg and colours of 90–150°EBC. Chocolate and black malts and roasted barley are also prepared in roasting cylinders but, relative to amber and brown malts, the heating is much more severe and there is a risk that the grain may catch fire. The process must be regulated so that no charring occurs and that when cut the grains are evenly coloured and have a floury texture, with no glassiness, and have the correct colour throughout. Well-modified green malt (TN 1.5–1.7%) is carefully dried and dressed. The material is loaded into a roasting cylinder and the temperature is increased from about 75°C (167°F) to 175°C (347°F) and then more slowly to 215°C (419°F) for chocolate malts and to 225°C (437°F) for black malts. During roasting, unpleasant fumes are released and these must be eliminated by scrubbers or after-burners. Roasted barley is finished at a higher temperature, 230°C (446°F). Towards the end of roasting, when the heaters are switched off, the temperature of the load continues to rise as heat is generated in the grain. At this stage the operator checks colour every 2–3 min. and at the correct moment quenches the load with a spray of water.

Roasted barleys usually have colours in the range 1200–1500°EBC. These are used in making some stouts and impart 'sharp', 'dry', 'acidic' or 'burnt' notes to the product. In contrast to roasted malts roasted barley gives no hint of sweetness. The roasted grains

should be reddish-black, shiny and swollen and a proportion will be split. Extracts are HWE, 260–275 l^o/kg, and moisture contents will be less than 2%. Pale chocolate malts will have colours of 500–600 °EBC, and the more usual chocolate malts 900–1100 °EBC. Black malts have colours of 1200–1400 °EBC. All have moisture contents of 2% or less and extracts of 255–275 l^o/kg. Flavour descriptions of these materials are not satisfactory, but they include ‘dry’, ‘burnt’, ‘acid’ and ‘astringent’ but when chewed they have a residual sweetness which is distinct from the flavour of roast barley. The hot water extracts of chocolate and roasted malts and roasted barley are determined on finely ground samples mashed with boiling water at 100 °C (212 °F) in the IoB method, so enzymolysis is not involved.

Crystal and caramel malts are unique in that during their preparation the endosperm contents are deliberately mashed, stewed and liquefied and, when cut, the finished malts should be hard and all the grains should be glassy or ‘crystalline’ in appearance. These malts are prepared in a wide range of colours, some of which are named. They impart rich and delicious and other characteristic flavours and they give body to beers and are believed to improve beer stability. Sound barley, sometimes with a high nitrogen content of 1.7–2.0%, is malted. When it is well modified either the green malt is taken to a roasting drum directly or, less economically, it is lightly kiln dried. The green malt, or the re-wetted, kilned malt is warmed and held moist at a temperature of 60–75 °C (140–167 °F) until the contents of the grains are liquefied and the liquid contents can be squeezed out. The temperature is then increased and the grain is ventilated with hot air so that both cooking and drying occur. The liquefaction step ensures that starch, and possibly the endosperm cell-walls, are degraded and sugars and other soluble materials accumulate. Thus on heating and drying and depending on the exact conditions a concentrated sugar solution is produced together with various amounts of melanoidins and flavour and aroma substances.

The finished product is rapidly cooled, and the contents solidify to a sugary, solid mass. Moisture contents are 3–7.5% and extracts are 260–285 l^o/kg; 76–80%. Preferred colour ranges are about 20, 120–140 and 300–500 °EBC. While the palest crystal malts are sweet, the darker malts have more complex flavours with caramel-, toffee-, malty-, aromatic-, honey-like and luscious characters becoming more apparent until in the darkest products harsher, burnt flavours appear. These products are variously called caramel or crystal malts. It has been shown that the flavour spectra can usefully be varied (Chandra *et al.*, 1999).

2.2.7 Malt specifications

When brewers purchase malt they require it to be excellent in quality and moderate in price. They expect the extract yield and quality will be good and that beer production will run smoothly and yield a good product. Malts have different properties and are used to produce different types of beer. Brewers need to decide what analyses define the best malt with which to make a particular beer, and to agree with maltsters that this is what can and will be supplied. The analyses available do not reliably predict a malt’s brewhouse performance and brewers have yet to agree on what set of analyses should be used to specifically define a malt. Cheap, poorly made malts are often undermodified and/or inhomogeneous and brewing with them can give rise to costs resembling those arising from mashing with excessive levels of particular adjuncts. For example, failure to recover the expected extract in the brewhouse or the need for a lengthened mashing programme, slow wort separation prolonging the lautering stage and so disrupting the

production programme, excessive break-formation in the hop-boil, short filter runs and slow beer-filtration rates so the production cycle is further disrupted and extra filter aids, e.g., kieselguhr (diatomaceous earth) may be needed. Furthermore, there may be a need to use extra beer stabilization treatments and/or add extra enzymes to the mash. Inadequate yields of small nitrogenous molecules (FAN), that then limit yeast growth and fermentation, may also occur as may low carbohydrate fermentability (too few fermentable sugars) that ensures that alcohol yield is depressed. All these problems cause disruption in the production schedule and increase costs.

In practice, brewers use different analyses in attempts to ensure that malts meet their requirements and the situation is complicated by the ongoing search for and introduction of improved methods (Aastrup *et al.*, 1991; Briggs, 1998; Buckee, 1997; Copestake, 1998; Gromus, 1988; Hyde and Brookes, 1978; Seward, 1992). The brewer may specify the variety(ies) of barley from which the malt may be made, and the harvest year, whether or not abrasion and/or additives may be used, details of the kilning cycle, and a minimum (or maximum for coloured malts) period between manufacture and delivery. A specification will contain an upper limit to screenings (thin corns) and dust, a maximum moisture content, a measure of the laboratory extract coupled to a lower limit, sometimes a preferred range for the fine-coarse extract difference, a total nitrogen (protein) limit or range, a range or limit for the total soluble nitrogen (protein) value and for the SNR or Kolbach Index, and often a lower limit for the free amino nitrogen. Values (maximum, minimum or ranges) may be specified for DP, α -amylase and saccharification time, and limits may be set on the concentration of the DMS precursor.

In addition, an upper limit or a range will be set for the colour of the laboratory wort, often before and/or after boiling. To these may be added specified limits for the other characteristics of the laboratory wort, including smell, clarity, pH, viscosity and β -glucan content, and estimates of malt β -glucanase, friability, homogeneity, and any others, including wort fermentability. As many of these values can be determined in more than one way and the results of analyses may be expressed in non-standard ways, even including non-standard units, a maltster in international trade may need to recognize nearly 300 analytical values, a situation so bizarre as to be ridiculous. In addition a guarantee may be needed to indicate that the malt is not contaminated with lead, arsenic or nitrosamines, mycotoxins or unapproved agricultural chemicals, insecticides or fumigants.

Two other kinds of problem arise. The first relates to the brewer specifying combinations of malt characteristics that cannot be combined in one product. For example, it is not possible to produce a pale malt with a very rich flavour, or an enzyme rich malt that has a high colour. Malts with low SNRs cannot be made highly friable. Barleys with low nitrogen (protein) contents cannot be malted to give products exceptionally rich in enzymes, high nitrogen contents cannot be combined with high carbohydrate extracts. Malts with poor physical modification cannot have low β -glucan contents, and so on. These facts are the inevitable consequences of the composition of barley and the integrated way in which changes in the grain occur during malting. The second kind of difficulty arises from drawing up specifications that are too inflexible, or 'tight', so that they cannot be met routinely. For example, it is ridiculous to specify a particular analytical value without taking account of analytical variations and the variations that occur in barley. It is meaningless to specify that a malt's nitrogen content, TN, must be 1.65% exactly, when the repeatability and reproducibility values for the analysis are 0.049% and 0.085% respectively according to the *Recommended Methods of the Institute of Brewing*. Realistic specifications must be agreed between maltsters and

brewers, probably annually, taking into account the changing varieties of barley being grown and the quality of the barleys available from the current harvest.

2.3 Adjuncts

Adjuncts are materials, other than malt, that are sources of extract (Briggs, 1998; Byrne and Letters, 1992; Letters, 1990; Lloyd, 1986, 1988a, b; Martin, 1978; Stowell, 1985). They are used because they yield less expensive extract than malt and/or they impart desirable characteristics to the product. For example, they may dilute the levels of soluble nitrogen and polyphenolic tannins in the wort, allowing the use of high-nitrogen (protein rich) malts and the production of beer less prone to form haze. Some adjuncts enhance head formation and retention. The higher proportion of adjuncts used in a mash the more difficult it is to achieve good extract recoveries and also wort viscosity is often increased, run off is slowed and fermentability is reduced. The addition of soluble sugars or syrups to the wort effectively increases the capacity of the brewhouse and provides a simple method for generating high-gravity worts and adjusting wort fermentability. Solid, 'mash tun' adjuncts may be added to the grist and the starch they contain will be hydrolysed by enzymes from the malt or from other sources (Section 2.5). Other soluble preparations, sugars and syrups, otherwise 'copper'- or 'kettle'-adjuncts, are dissolved in the wort during the hop-boil. In addition to these a brewer may add other sugars to the beer as 'primings', and caramels or other materials may be added to adjust beer colour.

Adjuncts are analysed according to the official sets of methods (Section 1.15.1, p. 9). Since, like special malts, mash tun adjuncts are largely or wholly lacking in hydrolytic enzymes, analytical mashes are made with adjunct, which may be pre-cooked and mixed 50:50 with an enzyme-rich malt. The extract yield of the adjunct is calculated, assuming that the extract recovered from the malt is half that which is obtained from an all-malt mash. The copper adjuncts are dissolved and the characteristics of the solutions are determined. The analytical values of interest include the specific gravity and hence the extract, the colour and clarity of the wort (often the colour is very low), the yield of soluble nitrogen, the oil content, the sulphur dioxide content, the pH, the ash content, levels of heavy metals (such as iron, copper, lead and arsenic), the level of microbes, the spectrum of sugars present and the fermentability of the mixture, the flavour, aroma and purity of the material and the absence of any deterioration. The amounts of adjuncts used vary widely. In some places their use is forbidden. In North America 60% of the extract in a brew may be derived from adjuncts, while elsewhere 10–20% is more usual. It is feasible to make beers with up to 95% of the grist being raw barley (Briggs *et al.*, 1981; Wieg, 1973, 1987).

The choice of adjunct(s) requires care. The material chosen must be regularly available in adequate amounts and be of good quality. The use of this material must enhance, or at least not reduce, the quality of the beer being made. It is difficult to switch between different kinds of adjunct. Apart from the risk of altering the nature of the beer, changing adjuncts may require alterations in the brewery equipment. For example, the handling plant needed for syrups is completely different from that needed for any mash tun adjunct and the equipments needed to handle flours, flakes and grits are all different.

2.3.1 Mash tun adjuncts

Mash tun adjuncts fall into three classes, those that can be mixed into the grist without pre-cooking, such as wheat flours, those that are pre-cooked before mashing begins (e.g.

flaked maize, torrefied wheat) and those that are cooked in the brewery as part of the mashing programme, such as maize-, rice- and sorghum-grits (Tables 2.1, 2.2). The type of adjunct that a starch-rich material produces is largely determined by the gelatinization temperature of its starch (Table 2.3; Chapter 4). If the starch granules swell and lose their structure and become susceptible to rapid enzyme attack (i.e. gelatinize) at temperatures low enough for the malt enzymes to remain active, then that material (e.g. wheat flour) need not be pre-cooked. However, if the starch has a high gelatinization temperature (e.g. maize) the material must be cooked at a high temperature to gelatinize the starch (either by flaking or in a cooker at the brewery site) before it is mixed with the main malt mash at a temperature at which the malt enzymes can act.

Raw barley grain has been used as an adjunct after hammer-milling or other kinds of dry-milling or wet-milling. It is an advantage to wash the grain before use (Briggs *et al.*, 1981; Wieg, 1973, 1987). The viability of this grain is irrelevant. It contains β -amylase (a proportion of which is insoluble) and some other hydrolases, as well as proteins inhibitory to some α -amylases, proteases and limit dextrinase. Mashings containing much raw barley often need to be supplemented with enzyme mixtures from microbes containing α -amylase, protease and β -glucanase to convert the starch, to provide sufficient amounts of FAN and to degrade the relatively large amounts of β -glucans that are present. Coarsely ground grain gives poor extract recoveries, but finely ground grain, while giving higher yields of extract, causes problems, in particular even greater quantities of β -glucans are extracted. Because of practical difficulties, including the need for prolonged temperature programmed mashings and problems with the lack of desired character and raw-grain flavours in the products, interest in 'barley brewing' has declined.

Wheat has been processed in various ways, but most wheat is used as flour. Wheat flour milling is a specialized process that, by a series of roller milling and sieving steps, can produce material that is nearly pure endosperm tissue. By removing the germs and bran the starch percentage in the product is increased while the protein, ash and oil contents are reduced. Brewing flours are prepared from soft wheats, and often the nitrogen contents of the flours are high. By using air classification fractions can be obtained that are depleted in protein and enriched in starch and so yield higher extracts. For example, air classification of a flour containing 9.5% protein gave a fraction with only 7% protein. The nitrogen-reduced material is used in brewing while the nitrogen-enriched material is used in making biscuits. Handling flour is not simple. Special hoppers, usually equipped with vibrating feeds, are needed to ensure that the flour flows and specialized conveying equipment (vibrating or pneumatic) is needed. Flour dust mixed with air can form explosive mixtures and so all the usual precautions must be taken.

To minimize handling problems, flours with 'clumps' of starch granules, cell walls and protein have been prepared, with particle diameters of about 100 μm (rather than the more usual 17–35 μm) but perhaps the most convenient preparations are those in which the flour particles are 'agglomerated', that is, bound together with a soluble binder so that the material produces little dust and is handled in a granular form. In the mash the granules disintegrate releasing the flour. Wheat flour has a high extract content (340 l^o/kg, on dry, Table 2.1), and its use favours haze stability and especially head formation and retention. Raw or pre-gelatinized rye or millets, used in relatively small amounts, support head retention better than wheat (Stowell, 1985). However, wheat flour retards wort separation both because pentosans increase the viscosity of the wort and because they and proteins form fine particles that block the mash bed. Lipid micelles may also

Table 2.1 Typical analyses of some starch-rich adjuncts

Adjunct	Moisture %	Hot water extract			TN (% d.b.)	TSN (% d.b.)	Bulk density (kg/l)
		(1°kg as is)	(1°kg d.b.)	(% d.b.)			
Maize grits	12	301	342	90	1.5	–	0.76
Maize flakes	9	313	344–355	–	1.5	0.04	0.46–0.66 ^a
Starches, refined	10	347	380–390	102–105	< 0.1	Negligible	0.60–0.70
Rice grits	11	316	355	93	1.0	–	0.85
Rice flakes	9	325	357	–	0.85	–	0.30
Wheat flour	11	304	342	–	1.5	0.36	0.51
Wheat, torrefied or micronized	4–9	291	310–315	–	1.6–2.0	0.15	0.55
Wheat flakes	5–8	287	302	–	1.8	0.12	0.37–0.40
Wheat, raw	12	260	295	–	1.6	–	0.77
Barley, torrefied	5–6	254	267	72	1.8–2.2	–	0.37–0.40
Barley, flaked	9	253	278	–	1.8	0.12	0.25–0.26
Barley, raw	12	250 ^b	284 ^b	–	1.8	Variable ^b	0.65–0.66

Analyses IoB (1993) except HWE (%), determined by the ASBC method (ASBC, 1992).

^aDepends on the degree to which they are crushed.

^bDepends on added enzymes.

From Lloyd (1986, 1988a); Brookes and Philliskirk (1987); Briggs (1998).

Table 2.2 Analysis (ASBC) of various adjuncts

Adjunct	Moisture (% as is)	Extract		Protein (% as is)	Fat/oil (% as is)	Fibre (% as is)	Ash (% as is)	pH	Gelatinization temperature range	
		(% as is)	(% on dry)						(°C)	(°F)
Corn (maize) grits	9.1–12.5	78.0–83.2	87.7–92.8	8.5; 9.5	0.1–1.1	0.7	0.3–0.5	5.8	61.6–73.9	143–165
Corn (maize) flakes	4.7–11.3	82.1–88.2	91.0–93.4	–	0.31–0.54	–	–	–	–	–
Refined maize grits (maize starch)	6.5–12.3	90.6–98.3	101.2–105.6	0.4	0.04	–	–	5.0	61.5–73.9	143–165
Rice grits	9.5–13.4	80.5–83.8	92.2–96.1	5.4; 7.5	0.2–1.1	0.3–0.6	0.5–0.8	6.4	61.1–77.8 ^a	142–172 ^a
Sorghum grits	10.8; 11.7	81.7; 81.3	91.4; 91.1	8.7; 10.4	0.5; 0.65	0.8	0.3–0.4	–	67.2–78.9	153–174
Wheat flour	11.5	80.1	90.7	11.4	0.7	–	0.8	–	–	–
Wheat starch	11.1; 11.4	86.5; 95.2	105.2; 97.5	0.2	0.4	–	–	5.7	51.7–63.9	125–147
Torrefied wheat	4.9	74.4	78.2	12.2	1.0	–	–	6.2	–	–
Torrefied barley	6.0	67.9	72.2	13.5	1.5	–	–	5.9	–	–

^a Variance in US rice types: 65–68 °C (149–154.4 °F); 71–74 °C (c. 160–165 °F) (long grain rice).

Data of Canares and Sierra (1976); Coors (1976); Bradee (1977); Canales (1979); through Briggs (1998).

Table 2.3 Some reported gelatinization temperature ranges of starches (Briggs, 1998; Reichelt, 1983; Various). Reported values often disagree, probably because different methods have been used to determine them (Bentley and Williams, 1996). The values reported in °F are only approximate equivalents of the temperature in °C

Starch	Gelatinization temperature range	
	°C	°F
Maize (Corn)*	62–77	143–171
Waxy Maize*	62–80	143–176
Sorghum*	69–75	156–167
Millet*	54–80	129–176
Barley	60–62	140–144
Barley, small granules	51–92	124–198
large granules	60–65	140–149
Barley Malt	64–67	147–153
Wheat	52–66	126–151
Rye	49–61	120–142
Oats	52–64	126–147
Rice*	61–82	142–180
Rice, short grain*	65–68	149–155
Rice, long grain*	71–74	160–165
Potato	56–71	133–160
Tapioca	63–80	145–176
Arrow root (Maranta)	67–85	152–185

* Starches or adjuncts made from these materials must always be cooked before mashing. The other materials may be converted better if first cooked.

contribute to these filtration problems, as they do with the filtration problems encountered with wheat starch hydrolysates (Matser and Steeneken, 1998). Sometimes these problems can be reduced by adding microbial pentosan-degrading enzymes to the mash.

Wheat flour is now used to about 5–10% malt replacement in some British breweries although, in the past, much higher replacement rates, of 25% or even 36%, were used (Briggs *et al.*, 1981). Wheat flour is used directly in infusion mashes, but higher extracts may be obtained if the flour is pre-soaked or is pre-cooked. From time to time purified starches from wheat, potatoes, manioc and other sources are used in mashing, depending on local economics. It might be expected that wheat starch would be fully converted in the mash, but it has been reported that better extract recovery occurs if the material is cooked at 96 °C (c. 205 °F), possibly because the small starch granules are gelatinized only at the high temperature. The material is not boiled to avoid frothing.

Flours are produced, as by-products, during the manufacture of maize, rice and sorghum grits. Like the grits these flours must be cooked before being mixed in with the malt mash. The extract yields of refined starches are high since, due to the uptake of the water of hydrolysis during conversion, 100 units (on dry) of starch give rise to 103–105% units of dry sugars and dextrins, so extracts of 380–390 l/kg (on dry), or 102–105% (on dry) are obtained. Generally, purified maize starch is not used directly in breweries although when it is it is cooked. Most brewing sugars are prepared from maize starch.

Pre-cooked adjuncts used in mashing include micronized and torrefied whole grains or flaked wheat or barley or flaked maize grits or flaked rice grits or flaked pearl barley (Tables 2.1, 2.2). These materials are easily handled and, because they have been cooked, they yield better extracts than the raw materials because their starches are gelatinized and

the hemicelluloses are partly degraded. They are easily broken up in malt mills. Whole grains of wheat or barley, graded to remove thin grains and with adjusted moisture contents, are cooked in hot air at 220–260 °C (428–500 °F). During cooling the softened material becomes firm and has a moisture content of about 4%. Torrefied barley may have an extract (on dry) of 267 l^o/kg or 72%, while for torrefied wheat the values may be 310–315 l^o/kg or 78–80%. It is advantageous to use grains with low nitrogen contents, since a 1% increase in nitrogen content (6.25% crude protein) will reduce the extract yield by 5%. Micronized cereal grains have similar properties. These are prepared by cooking in a thin layer, moving beneath gas flame heated ceramic tiles which give out radiant heat (infra-red radiation). The grain, which should be carefully conditioned and not heated for too long a period to obtain the best quality product, reaches a temperature of about 140 °C (284 °F) (Brookes and Philliskirk, 1987; South, 1992). Micronized grains may be cooled and mixed with the malt before it is milled. While it is still hot, micronized grain may be rolled to form flakes, which do not need to be dried.

The older process, for flaking whole grains, or pearl barley or maize- or rice-grits, began by adjusting the moisture content of the material then, after a period of conditioning, cooking at 90–100 °C (194–212 °F), flaking it by passing it between hot rollers. The flakes were dried in a stream of hot air, before cooling. At present (2004) it is not economic to use flaked rice but it, like flaked maize, is a well-liked adjunct that gives up its extract easily, in good yield, even in simple infusion mashes (Table 2.1). Flaked barley and, to an even greater extent, flaked pearl barley (grains from which the husk and surface layers have been removed by abrasive milling; Briggs, 1978) give problems in brewing largely because they contain comparatively large amounts of β -glucan. Flaked barley has been prepared sprayed with a solution of bacterial enzymes containing α -amylase, β -glucanase and probably protease. The product had an appreciable cold water extract and did not give rise to highly viscous worts or any of the other problems associated with β -glucans. In the past flaked oats were used in making some stouts. They were described as being greyish, with low extracts of 252–282 l^o/kg, and were rich in husk, protein and in oil that could readily become rancid. Experimentally it has been shown that milled, cooked and extruded cereals are convenient adjuncts (Briggs *et al.*, 1986; Dale *et al.*, 1989; Laws *et al.*, 1986). These preparations seem to be used only in the preparation of some African beers.

Grits are preparations of nearly pure starchy endosperm in which the starch granules are invested with protein and are enclosed with cell walls (Johnson, 1991). For brewing purposes these are prepared from maize ('corn'), rice or sorghum (Tables 2.1, 2.2). These grits must be cooked before being mixed with the main malt mash. The high temperatures used (up to boiling or, when processed under pressure, even over 100 °C; 212 °F) disrupt the cellular structure of the grits and gelatinize the starch. The α -amylase included in the mixture liquefies some of the starch, reducing the viscosity of the mixture and preventing retrogradation. The α -amylase may be bacterial in origin or it may be from a small amount of highly enzymic, ground malt. Brewing rice is usually a by-product of grain being prepared for human consumption. This material has become too expensive to use in many areas, but it is still used in Asia. Preferred rice grits are less than 2 mm (0.079 in.) in diameter, have moisture contents of about 13%, and extracts of 88–90 or even 95% (on dry). Typically they contain 5–8% protein and 0.2–0.4% oil and about 0.9% ash. The flavour imparted to beers by rice are described as neutral, 'dry', 'light' and 'clean'.

Different grades of rice behave very differently in mashing, so that wort separation times may vary by factors of 2 or 3 and the gelatinization temperatures of the starches vary widely (Table 2.3). When rice grits are slurried in water and are progressively heated it is

found that the gel point of each sample (the temperature at which the viscosity suddenly increases) is related to the difficulties of using the material in the brewhouse (Teng *et al.*, 1983). It is advantageous to use a thermostable bacterial α -amylase when cooking rice. It seems that all rice grits should be heated to boiling. Rice grits, like maize grits, may be cooked and flaked. Flaked preparations are used in brewing without the need for a cereal cooker. Typical analyses of maize grits, which are prepared from yellow dent corn by a dry milling process, are: moisture 13%; protein 7–9%; fat, 0.7–1%; ash, 0.5–0.7%; extract about 90% (on dry). Usually particles have diameters of 0.3–1.5 mm, 0.012–0.059 in. (Tables 2.1, 2.2; Johnson, 1991). These grits impart a fuller flavour to beer, compared to rice grits. In some areas, notably Africa and Mexico, sorghum grits are used. In quality they closely resemble maize grits, giving extracts of 91% (on dry), with moisture contents of 11–12%. When first used sorghum grits gave unpleasant flavours to beers, but improved milling techniques, processing large yellow or white, low tannin grains, now produce fully acceptable materials. Pearl barley is analogous to grits, being almost pure endosperm tissue. It does not need to be cooked but it is now little used in brewing. Grits can be prepared from several millets, but this is probably not done commercially.

2.3.2 Copper adjuncts

Copper adjuncts come in two categories (Table 2.4). First, wort extenders, which add essentially only carbohydrates (such as sucrose, invert sugar and hydrolyzed starch syrups) and wort replacements such as malt extracts and syrups made from hydrolyzed cereals. These materials add carbohydrates and a complex mixture of other substances to the process stream. The formulae of sugars are given in Chapter 4.

Sucrose ('sugar'), derived from either sugar cane or sugar beet, is a well-liked copper adjunct, used either as a solid or in solution and either as the disaccharide sucrose (α -D-glucopyranosyl-(1,2)- β -D-fructofuranose) or as the hydrolysis product, the equimolecular mixture of glucose and fructose, 'invert sugar', so called because as the sucrose is hydrolysed the optical rotation of the solution decreases and becomes negative and 'inverted'. At present, with the exception of Australia, sucrose-based materials are little used because they are costly. Beet sugar must be used pure, because the impurities have unpleasant flavours. While pure cane sugar is perfectly acceptable, partially purified preparations have been preferred because of their luscious flavours. These preparations may contain small quantities (perhaps 5%) of unfermentable di- and tri-saccharides (Table 2.4). Sucrose is extremely soluble (see Appendix), solutions containing over 63% solids being attainable. However, concentrated solutions of pure sugars are liable to crystallize. Solutions of invert sugar containing 83% solids can be prepared. Some brewer's preparations contain both sucrose and invert sugar. Yeasts ferment these sugars easily so, as the sugars dissolve completely in the wort, extract recovery is 100% and, with the pure preparations, the added sugars are 100% fermentable. The sugars may be provided in solution or as solids. A sugar syrup may give an extract of 258 l/kg (fresh wt.), have a specific gravity of about 1.33 and a colour of 3–12 °EBC. Nitrogen contents (e.g. 0.01%) are negligible. An invert sugar preparation may have an extract of 318 l/kg (fresh wt.; Table 2.4). To prevent crystallization and to reduce the viscosity, so improving handling characteristics, these sucrose or invert sugar syrups are handled and stored warm, at 40–50 °C (104–122 °F). They cannot be stored for long periods, and so must be delivered shortly before use.

Sugar adjuncts used in small amounts include lactose (from whey; a sweet, non-fermentable sugar), honey and maple syrup (Wainwright, 2003). Many sugar preparations

Table 2.4 Typical analyses of sugar-rich brewing adjuncts, priming sugars and caramels

Preparation	Hot water extract (f.wt.) (1°/kg) ^a	Total nitrogen (f.wt.) (%)	Colour 10% w/v solution (EBC units)	Fermentability solids (%)	Specific gravity (20 °C)
Sugar preparations					
Raw cane sugar syrup	258	0.01	3	95+	1.33
Invert sugar liquid	318	0.01	3–12	95+	1.43
Sugar primings	310	0.01	3–12	95+	1.42
Refined maize-starch hydrolysates					
Brewing syrup	310	0.02	Colourless or adjusted ^b	77–78	1.42
Confectioners' glucose	318	< 0.01	Colourless	30–50	1.43
Solid brewing sugar	310	0.02	Colourless or adjusted ^b	86–87	–
Glucose chips	318	0.01	20–50	82	–
Other materials					
Grain-based syrup	302	0.4–0.8	4	65–70	1.40
Malt extract	302	0.65–1.3	4	70	1.40
Caramel, 46,000 liquid	242	–	4600	–	1.29
Caramel, 32,000 liquid	284	–	3200	–	1.36

^a Dry, solid sugar preparations, e.g., sucrose, have values of 382–386 1°/kg.

^b FAN values of 0.01–1.15%. The colour may be adjusted to specification by the addition of other sugar-based products.

Analyses IoB.

After Lloyd (1986, 1988a); through Briggs (1998).

are made from 'refined grits', refined maize starch (corn flour). This is prepared by a continuous wet milling process. Maize grain is soaked in a solution of sulphur dioxide and is then broken up. The oil-rich germs and hulls are separated and the remaining endosperm tissue is milled and the gluten and starch granules are separated. The starch is recovered as a 35–40% suspension in water. This material may be dried. The powdery product is dusty and must be handled with all the precautions used with flours. Sometimes starch is added to the cereal cooker with grits, but it is usually converted into solutions of hydrolysis products by specialist manufacturers. A sample of maize starch had an amylose:amylopectin ratio of 28:72, a moisture content of 11–12%, a crude protein content of 0.35% and a fat content of 0.04 to 0.5%. The dry component of this material was mainly polysaccharide. Most maize starch is used in brewing, after hydrolysis, as syrupy copper (kettle) adjuncts. The starch is treated in two stages. In the first stage it is cooked to disrupt the granules and the material is treated with a mineral acid or a thermostable bacterial α -amylase (stabilized by additions of calcium salts) to 'liquefy' the polysaccharide, degrading it to a mixture of dextrans, oligosaccharides and sugars. In part the high cooking temperature is needed to disrupt amylose-lipid complexes, making the polysaccharide more easily degraded. The liquefied mixture flows and has a comparatively low viscosity, in contrast to cooked, but not liquefied, starch which is very viscous and sets to a gel on cooling. The liquefied material is partly purified by treatment with active charcoal and/or ion exchange resins to remove lipids and ionic substances. If mineral acid was used then this must be neutralized if the next process is to be enzyme-catalysed. In the second stage the liquefied material is saccharified to produce the mixture of carbohydrates finally required. Saccharification may be carried out with mineral acid or, after adjustment of the pH, with one or more enzymes.

A very wide range of products, varying in salt content, sugar spectra and fermentability, are available. The materials may be classed as acid/acid, acid/enzyme or enzyme/enzyme products. Those prepared using acid hydrolysis may have high salt contents and, because of side reactions occurring during hydrolysis, may contain oligosaccharides containing unusual inter-sugar linkages, and may be coloured and have characteristic flavours. Thus acid/acid hydrolysis can yield confectioner's 'chip sugar', which is rich in glucose and with colour in the range 200–500 °EBC. Acid/enzyme and enzyme/enzyme products may be produced with little colour and with closely controlled compositions. They may be dried and delivered as solids or in solution as liquid syrups. Generally, like the sucrose-based syrups, these syrups are kept warm (at 50 °C; 122 °F) or above) to prevent crystallization and the separation of solids from the mix and to reduce the viscosity. They may be delivered and stored at 60–70 °C (140–158 °F). The surfaces of the stored materials are often ventilated with sterile air to remove water vapour which otherwise might condense and drip back onto the surface of the syrup, so locally diluting it and allowing the proliferation of microbes, notably osmophilic yeasts. The headspace may be filled with nitrogen or be illuminated with sterilizing, ultraviolet light.

Often syrups contain sulphur dioxide as a preservative (2–40 mg/l), and brewers specify an upper concentration. Syrups are described as having reducing dextrose equivalent (DE) values. However, as different mixtures of sugars and dextrans can have the same DE values, these are of limited use to brewers. Preparations can be obtained with fermentabilities ranging from 30–95%, but usually values are about 75–85%. These syrups can be used to adjust the final fermentability of wort. However, the fermentability of a syrup is not a sufficient characterization, the spectrum of sugars present is also significant. Thus the fermentable material may be rich in glucose, or be

nearly entirely glucose. This may be undesirable since yeasts in worts rich in glucose may not be able to adapt to metabolize maltose and maltotriose, leading to slow or 'hanging' fermentations. Glucose-rich syrups are usually made with the enzyme amyloglucosidase, sometimes mixed with a debranching enzyme to accelerate the hydrolysis of the starch and dextrin β -1,6-linkages. This problem does not arise if most of the fermentable carbohydrate is maltose. Maltose-rich syrups are made by incubating liquefied starch with a β -amylase (a plant enzyme or the enzyme derived from *Bacillus polymixa*) and a debranching enzyme such as pullulanase.

Starch-derived syrups and malt extracts and syrups prepared from cereal grains are introduced into the wort during the hop-boil, as are solid sugars (Chapter 10). All these materials must be dissolved and fully dispersed. If this is not achieved and material settles in the copper, the sugars can burn on to the heating surfaces with the creation of heating and cleaning problems, a loss of extract and perhaps the generation of unwanted flavours and colours. As prepared these syrups are very pale but, if required, makers may add caramel to give a specified colour.

Other copper adjuncts are malt extracts or syrups obtained by hydrolysing cereal grains (Briggs, 1978, 1998; Tables 2.4 and 2.5). These materials contain both carbohydrates and a complex mixture of substances including nitrogenous materials, minerals and yeast growth factors. Additions of these materials to the wort are equivalent to adding concentrated wort to the beer production stream. Malt extracts are made by grinding the malt, mashing it, with or without mash tun adjuncts and supplementary enzymes, and separating the wort, then concentrating it using triple effect vacuum evaporators. Many types of material can be produced depending on the grist, the mashing programme employed and the evaporation conditions used. By mashing enzyme-rich malts at low temperatures and concentrating the worts at low temperatures, enzyme-rich malt extracts may be obtained. At the other extreme, by heating the wort strongly, sometimes at a reduced pH, before concentration a product lacking enzymes can be prepared. Extracts can contain 75–82% solids (SG values 1400–1450), the more concentrated materials being used in the tropics. To keep the preparations liquid they need to be kept warm (e.g. 50°C, 122°F). At this temperature the material will slowly continue to darken and its other characteristics will change, so it should be used promptly. A representative extract is 302 l/kg (fresh wt.). Colours may range from 3–520°EBC, have varied enzyme contents (DP 0–400°L), and fermentabilities in the range 56–93%.

Some of the mash grists contain large proportions of raw cereal or cereal adjuncts, and to obtain adequate extracts the mashes may be supplemented with microbial enzymes and long, rising temperature programmes may be used. These products are best termed cereal syrups. A distinct product was 'liquid malt'. This was made by mashing green barley malt, so eliminating the cost of kilning. The wort was concentrated in the usual way and the unwanted flavour components were evaporated during the concentration stage. According to German law this material is not an adjunct and so, like conventional malt extracts, its use is permitted. Potentially such syrups are highly fermentable, can be enzyme rich and low in proanthocyanidins (anthocyanogens), and so their use favours haze stability in beers. Malt extracts and cereal syrups are used less by large-scale breweries than was once the case. In contrast syrups made by hydrolysing starches are widely used. While malt extracts were once added to supplement the enzyme contents of mashes this highly uneconomic practice has long been discontinued, at least in large-scale brewing. However, 3.7 volumes of malt extract give about the same amount of extract as 10 volumes of malt, making it a very compact source of extract, and it has been the practice to send malt extract (pre-hopped or not) to be fermented to make beer at

Table 2.5 The carbohydrate compositions (%) of two worts and several syrups prepared from starches (after Wainwright, 2003)

	Infusion mash wort	Decoction mash wort	Low fermentable syrup*	63 DE syrup*	High maltose syrup*	Very high maltose syrup*	High dextrose (glucose) syrup*
Glucose + Fructose	10	11	4	38	2	3	94
Sucrose	5	2	0	0	0	0	0
Maltose	45	52	10	33	55	68	3.5
Maltotriose	15	12	12	6	16	18.5	0
Dextrins [†]	25	23	74	23	27	10.5	2.5
Fermentability (%) [‡]	72	74.8	23.6	75.6	69.8	85.8	97.5

* Starch hydrolysates do not contain fructose or sucrose.

[†] Dextrins are not fermentable.

[‡] Calculated fermentability.

remote locations or on ships. In addition, hopped or unhopped malt extracts are used by many home brewers and small-scale or 'micro' brewers to avoid the inconvenience of the mashing and wort separation operations. Copper adjuncts effectively increase the production capacity of a brewery. They are convenient for preparing high-gravity worts and for adjusting wort fermentability. Most add insignificant amounts of nitrogenous substances or polyphenols, or flavours or colours to wort. The approved sets of analytical methods specify ways of evaluating copper adjuncts. In contrast to malts and mash tun adjuncts all the potential extract of a copper extract is recovered in the wort provided that it is completely dissolved.

2.4 Priming sugars, caramels, malt colourants and *Farbebieber*

The materials described in this section are not regarded as adjuncts. However, they all add extract to the wort or the product and so they are considered here. Priming sugars are added to beers that are to be cask- or bottle-conditioned. The object is to provide the yeast with a supply of easily fermented sugars that can indirectly supply the carbon dioxide needed to carbonate the beer, and 'bring the beer into condition'. Since the sugars are mostly fermented their nature is not important; sucrose, invert sugar and glucose- or maltose-rich syrups will serve. However, if the preparation contains a proportion of unfermentable material this will remain in the beer and may alter its character. To utilize some of the residual dextrins present in beer, enzymes have been added to catalyse the hydrolysis of a proportion into fermentable sugars, a procedure which removes the need for priming sugars. Various enzymes have been used for this purpose. Amyloglucosidase was unsatisfactory since it is too stable and so is not reliably destroyed by the temperatures reached during pasteurization. Consequently the enzyme continues to act and sweeten the beer when its activity is no longer required. Less stable enzymes such as fungal α -amylase, or pullulanase with β -amylase have been more successful, but the problem of deciding when the correct degree of dextrin degradation has occurred, and so when the enzymes must be inactivated, still remains. Sugars may be added to some filtered and sterile beers to sweeten them. If this is done then sucrose or high-fructose preparations are probably to be preferred.

Caramels are used to adjust colour by adding them to the wort or beer (Chapter 9). Caramels are made in different ways and not all types are suitable for brewing purposes (Comline, 1999). The class III, electropositive-ammonia caramels, the caramels used in beers, are made by heating sugars (usually high glucose syrups) with ammonia. Complex reactions occur and the product is a mixture of high molecular weight coloured substances and lower molecular weight substances which impart flavour and aroma. The preparations may have colours up to 35,000 °EBC, contain 65–75% solids, 2.5–5% nitrogen and have pI values of 6.0–6.5. (A pI value of a substance is the pH at which it is 50% ionized). By using ultrafiltration the coloured and flavoured components can be separated, permitting beer colour and flavour to be adjusted separately (Walker and Westwood, 1991). The specifications of brewing caramels usually include values for colour, pH, extract content, and stability when dissolved in worts and beers.

Sometimes the use of caramels is forbidden but it is permissible to use extracts from coloured malts. Crystal, chocolate or black malts (or roasted barley, where allowed) are extracted with hot water and the extracts are concentrated. Colours (of 10% solutions) of 850–1,700 °EBC may be obtained. It is not clear how widely these malt colourants are used. In Germany beer colour may be adjusted using *Farbebieber*. This 'colour beer' is

produced by specialist manufacturers (Narziss, 1992; Kunze, 1996; Riese, 1997). A mixture of, say, 60% pale malt and 40% dark malt is mashed to give a wort with a very high density (e.g. 18–20 °Plato, approx. SG 1074–1084). The extract is boiled and fermented in a special way to give a product with a colour of about 8,000 °EBC. It may be concentrated under vacuum. This material is undrinkable, but it is added to wort or beer to adjust the colour. Sometimes the material is treated with active charcoal to reduce bitter flavour.

2.5 Supplementary enzymes

Enzymes derived from sources other than malt may be used at various stages during brewing, provided that this is allowed by local regulations (Bamforth, 1986; Briggs *et al.*, 1981; Byrne, 1991; Godfrey and Reichelt, 1983). Enzymes are also used in the production of some adjuncts (Section 2.3). These enzymes are mostly prepared using liquid suspension cultures of various microbes (bacteria and fungi), but a few are obtained from plants and at least one was obtained from animal sources. The preparations, which may be dry powders or solutions, must be approved for use in foodstuffs. They are not 'pure', and will usually contain residual materials from the nutrient medium in which the microbes were cultured, other enzymes besides the one(s) specified, diluents, extenders or carriers, and preservatives. They should not contain viable microbes. The preparations available have a wide range of characteristics. Different suppliers describe their preparations in different ways so that it is difficult to make comparisons between them. The lack of standard analyses is a source of difficulties. The temperature and pH optima of enzymes are so influenced by incubation conditions, and the conditions used in different breweries and at different stages of brewing are so varied, that it is not possible to give useful values. Consequently the effectiveness of the addition of an enzyme preparation must be determined by brewers under their particular processing conditions.

The activities of 'named' enzymes in preparations are standardized by suppliers. However, this is not true of other enzymes that may be present. The presence of these additional enzymes may be advantageous or harmful. For example, the presence of β -glucanase in preparations of bacterial α -amylase may be beneficial when added to a mash, particularly if undermodified malt or barley or oats adjuncts are used in the grist. On the other hand, while the presence of protease activity may be an advantage if more FAN is needed, it is most undesirable if it elevates the levels of soluble nitrogen too far and/or if the degradation of protein leads to a reduction in foam formation or stability. The presence of some 'additional' enzymes can easily be detected (Albini *et al.*, 1987).

Enzyme preparations are not stable, so they should be stored cool and used fresh. Different enzymes in a mixture will usually have different half-lives, so the ratios of enzyme activities in a preparation will alter with storage time. This may generate problems. Many of the enzymes used in the manufacture of starch- and cereal-derived syrups may also be used in breweries. Usually enzymes, where used, may be added to the mash or the cooker, or they may be added to the wort or beer. Used intelligently they can improve extract recovery, wort collection rate, the rate of beer filtration and the length of filtration runs, wort fermentability, and the resistance of the beer to haze formation. Added enzymes can minimize the presence of residual starch or gums in the wort. Other uses are indicated later. The enzymes of most interest in brewing are those which catalyse the hydrolysis of starch and dextrins, those which attack hemicelluloses and gums (both

β -glucans and pentosans), and those which degrade proteins. However, other enzymes may be of interest. While some brewers may use added enzymes on a routine basis others use them only to combat unforeseen production problems.

α -Amylases used in brewing are from different sources and, because of their different properties, they are suited to different purposes. They are all stabilized by elevated levels of calcium ions and by their substrates, starch and dextrans. They are all *endo*-acting enzymes, that is they catalyse the hydrolysis of the α -(1,4)-links within the dextrin, amylose and amylopectin chains. However, the range of hydrolysis products differs significantly, and the enzymes differ in thermal stabilities to a remarkable extent. Fungal enzymes (usually from *Aspergillus* spp.) have pH optima in the range 5.0–6.5, and temperature optima of around 60–65°C (140–149°F), or 55°C (131°F). Despite these low values these preparations have been added to mashes where the complex mixture of ‘extra’ enzymes (which commonly include hemicellulases and proteases) may be of value. This type of enzyme, which is inactivated by pasteurization, has been added to beers to hydrolyse dextrans and so obviate the need for priming sugars. It produces appreciable amounts of maltose among its products.

Several types of bacterial α -amylase are in use. The enzyme from *Bacillus subtilis* has a pH optimum between 6.0 and 7.5, but it is usefully active at mash pH values, 5–6. The temperature optimum is around 65–70°C (149–158°F), but is strongly dependent on the presence of starch, which stabilizes it. The enzyme may act briefly at temperatures up to 80°C (176°F). Usually preparations of this enzyme, like those other bacterial enzymes, contain protease and β -glucanase activities. While the alkaline protease may have little action under mashing conditions the neutral protease does. The enzyme from another bacterium, *Bacillus subtilis*, var. *amyloliquefaciens* is appreciably more heat stable. This α -amylase has a reported pH optimum at 5.7–5.9 (at 40°C; 104°F). Although its temperature optimum is about 70°C (158°F) this enzyme is able to liquefy a 35–40% starch slurry at 85–90°C (185–194°F), and so it is useful for liquefying the starch when adjuncts are cooked, since it is so much more stable than the malt enzyme. In contrast the α -amylase from *Bacillus licheniformis* is too heat stable for some brewing purposes. This enzyme, which has a wide pH optimum around 6, has a temperature optimum at 90°C (184°F) at high calcium ion concentrations. It can act briefly at 115°C (239°F), and it is not reliably destroyed by boiling unless the solution is slightly acid and the calcium and starch concentrations are low. These conditions can be met when the enzyme is used to liquefy starch during the manufacture of sugars and syrups, but cannot be reliably achieved in brewing.

Debranching enzymes are used in the manufacture of copper adjuncts, and they have been investigated for use in the brewhouse. Two types of enzyme have been investigated. Isoamylase is able to hydrolyse the α -(1,6)-links in amylopectin but not in dextrans. This enzyme seems not to be of value in brewing. However, pullulanase, an enzyme produced by the bacterium *Klebsiella pneumoniae* (*Aerobacter aerogenes*), hydrolyses α -(1,6)-links in both amylopectin and in dextrans, including limit dextrans. The enzyme is thermolabile, and is used at 45–55°C (113–131°F), when saccharifying dextrans with amyloglucosidase or β -amylase in making glucose- or maltose-rich syrups respectively. The enzyme has been added to cooled mashes in experimental brewing, and it has been used, together with β -amylase, to replace priming sugars in beer. As it is readily inactivated by heat this process can be stopped by pasteurizing the beer. The pH optimum has been given as 5.5–6.0, but the enzyme has been used at values as low as 4.

α -Amylases may be obtained from plants or particular bacteria. Enzymes from cereals (including flours), soya beans and sweet potatoes have been used to saccharify dextrans,

with or without the addition of other hydrolases. The pH optima are about 5.3, but the useful pH range is about 4.5–7.0. These enzymes attack the penultimate α -(1,4)-links in starch chains, releasing the disaccharide maltose. They are readily denatured by heat, and have temperature optima around 55 °C (131 °F). These enzymes have been added to mashes to increase the wort fermentability, and they have been added to wort for the same purpose and to beers to replace priming sugars. These enzyme preparations often contain α -glucosidase (which is generally ignored) and may contain the unwanted enzyme lipoxygenase (LOX) as well as other enzymes. The bacteria *Bacillus polymixa* and *Bacillus cereus*, var. *mycoides*, produce both pullulanase and β -amylase which, acting together, have been used when making high maltose syrups.

Amyloglucosidase (syn. glucoamylase; AG; AMG) is prepared from several different fungi (e.g. *Aspergillus* spp., *Rhizopus* spp.). Some preparations also contain α -amylase and/or transglucosidase. The latter is undesirable as it catalyses the formation, by transglucosylation, of unwanted and unfermentable oligosaccharides such as isomaltose and panose. Amyloglucosidase attacks the non-reducing ends of starch chains and dextrans releasing glucose. Its attack on α -(1,4)-links is comparatively rapid relative to the attack on α -(1,6)-links, so the conversion of starch into glucose by this enzyme is accelerated by the addition of pullulanase. The optimal pH range is 4.0–5.5, and the enzyme will act for extended periods at 60–65 °C (140–149 °F). It has been added to mashes (particularly mashes containing large proportions of adjuncts) to increase the fermentability of the wort. It is regularly used in the production of glucose and has been added to beer to replace priming sugars. It is no longer used for this, being replaced by more thermolabile enzymes.

There is a proposal to add a glycosyl transferase to mashes to increase the levels of unfermentable isomaltooligosaccharides in the wort to produce a beer with a reduced alcohol content but with a full body. In contrast, the same enzyme added to cool, fermenting wort increases the fermentability and hence the final alcohol content (Robinson *et al.*, 2001).

When undermodified or inhomogeneous barley malts are used or when barley (or oats) mash tun adjuncts are employed, problems can arise in the brewery and these are often, at least partly, due to residual, high molecular weight β -glucans. Similarly, when problems arise from the use of wheat, rye or triticale adjuncts or wheat malt the problems are often attributed to pentosans. The problems include slow wort separation, slow beer filtration and short filter runs and sometimes the separation of hazes and gelatinous precipitates in the beer. The enzymes used to degrade β -glucans may be divided into β -glucanases and cellulases. Sometimes these preparations contain complex mixtures of enzymes. Because the structures of pentosans are complex (Chapter 4) mixtures of enzymes may be needed to obtain substantial degradation of these materials.

The β -glucanase of *Bacillus subtilis* is a well characterized enzyme, with an optimal pH range of 6.0–7.5 and temperature range of 50–60 °C (122–140 °F). In temperature-programmed mashes it acts best at about 50 °C (122 °F). However, the enzyme will act in brewery mashes, at least briefly, at about pH 5.3, at temperatures up to 75 °C (167 °F). This enzyme is specific in that it attacks only mixed-linked β -(1,3;1,4)-glucans. It has been used in mashes made with barley adjuncts, and it is usually accompanied by α -amylase and two proteases. Fungal β -glucanase preparations (e.g. from *Aspergillus* spp.) have varied properties, but usually have inconveniently low temperature optima (45–60 °C; 113–140 °F) for mashing but have convenient pH optima in the range 3.5–6.0. They probably contain a complex mixture of hydrolases, and are not clearly distinguished from the cellulases.

A preparation from *Humicola insolens* is active at degrading β -glucans at up to 75 °C (167 °F). Cellulases used in brewing include those from *Trichoderma* spp. (*T. reesei*; *T. viride*), with temperature optima of 50–55 °C (122–131 °F) and pH optima in the range 3.5–5.5. Such preparations are useful in temperature programmed brewery mashes. They contain mixtures of enzymes, including amylases and pentosanases. Cellulase preparations from *Penicillium funiculosum* have activity in the pH range 4.3–5.0, and function at temperatures of 65 °C (149 °F). Preparations from *P. emersonii* are more heat stable, with an optimal temperature of 80 °C (176 °F) and a useful optimum pH range of 3.7–5.0. The enzyme mixture attacks not only mixed link barley β -glucans but also holocellulosic material in barley, starch and pentosans. It is well suited for addition to mashes.

Pentosanases need to be complex mixtures of enzymes and contain acetyl esterase, feruloyl esterase, α -L-arabinofuranosidase, *exo*- (xylobiase) and *endo*-xylanase activities. Preparations usually contain starch-, cellulose- and β -glucan-degrading activities. Preparations have been made from *Disporotrichum*, *Trichoderma* and *Aspergillus* spp. Usually these are used in temperature-programmed mashes, being active at about 50 °C (122 °F). They are particularly useful when wheat, rye and triticale adjuncts are used.

Non-malt proteolytic enzymes are used for two purposes in brewing. First, by adding a protease to the mash, the amount of nitrogenous yeast nutrients (FAN; formol-N) in the wort is increased and, secondly, by adding a protease to beer, polypeptide haze precursors are degraded. Pepsin, an animal protease with an acidic pH optimum, was added to beer as a stabilizing agent, but this function is now carried out by thiol-dependent plant proteases, in particular papain, from the latex of the pawpaw (*Carica papaya*), bromelain from the pineapple (*Ananas* spp.) and ficin from figs (*Ficus* spp.). These enzymes differ a little in their properties. All are destroyed by pasteurization and, while they degrade haze precursors, they apparently do not degrade the desirable foam-forming polypeptides. In contrast the bacterial proteases do destroy foam precursors. Protease activities are often present in fungal enzyme preparations, with pH optima in the range 3–6, and temperature optima around 50 °C (122 °F). Probably the bacterial proteases are of most interest, since these have been added to mashes to increase the FAN levels. *Bacillus subtilis*, like some other *Bacilli*, produces proteases having neutral and alkaline pH optima. The mixture works at mash pH values, and has an optimal temperature of 45–50 °C (113–140 °F). When mashes are made that are rich in raw barley and are supplemented with bacterial enzymes an extended stand is needed at 50 °C (122 °F) to obtain an adequate level of soluble nitrogen in the wort. Raw barley contains an inhibitor of bacterial neutral protease.

Lipases, nucleases, phosphatases (including phytase), oxidases, transglycosylases, α - and β -glucosidases are enzymes of potential interest. It is generally considered that the presence of lipases (fat hydrolysing enzymes) and lipoxigenase is undesirable. It has been proposed that the addition of ‘tanninases’ to wort or beer should hazeproof the beer. How, or if, such enzymes might act on barley and hop proanthocyanidins is not clear, since these are not hydrolysable tannins. The enzyme α -acetolactate decarboxylase may be added to beer to break down its substrate to carbon dioxide and acetoin. Thus by destroying a precursor of diacetyl the flavour stability of the beer is improved (Section 12.10.2). Glucose oxidase has been added to beer to ‘scavenge’ oxygen, which is utilized to convert glucose to gluconolactone and hydrogen peroxide. This latter compound is itself an oxidizing agent and its presence is probably undesirable. It is degraded by the enzyme catalase to oxygen and water. The oxygen (half the amount initially used) is again used by the glucose oxidase, and so the amount present is progressively reduced.

2.6 References

- AASTRUP, S., BRANDT, J. and RIJS, P. (1991) *Louvain Brewing Letters*, **4**(1), 16.
- ALBINI, P. A., BRIGGS, D. E. and WADESON, A. (1987) *J. Inst. Brewing*, **93**, 97.
- BAMFORTH, C. W. (1986) *European Brewery Convention Monograph – XI. E. B. C. – Symposium on Wort Production, Maffliers*. p. 149.
- BEMMENT, D. W. (1985) *The Brewer*, Dec., p. 457.
- BENTLEY, I. S. and WILLIAMS, E. C. (1996) in *Industrial Enzymology* (2nd edn, Godfrey, T. and West, S., eds), Macmillan Press, London. pp. 339–57.
- BLANCHFLOWER, A. J. and BRIGGS, D. E. (1991) *J. Sci. Food Agric.* **56**, 103, 117, 129.
- BOIVIN, P. and MALANDA, M. (1998) *Proc. 25th Conv. Inst. Brewing (Asia Pacific Sect.)*, Perth. p. 30.
- BOURNE, D. T. and WHEELER, R. E. (1982) *J. Inst. Brewing*, **88**, 324.
- BRIGGS, D. E. (1978) *Barley*. Chapman & Hall, London. 612 pp.
- BRIGGS, D. E. (1987) in *Cereals in a European Context* (Morton, I. D. ed.). Ellis Horwood, Chichester. p. 119.
- BRIGGS, D. E. (1998) *Malts & Malting*. Blackie Academic & Professional, London. 796 pp.
- BRIGGS, D. E. (2002) *J. Inst. Brewing*, **108**, (4), 395.
- BRIGGS, D. E., HOUGH, J. S., STEVENS, R. and YOUNG, T. W. (1981) *Malting & Brewing Science, Vol I, Malt & Sweet Wort* (2nd edn). Chapman & Hall, London. 387 pp.
- BRIGGS, D. E., WADESON, A., STATHAM, R. and TAYLOR, J. F. (1986) *J. Inst. Brewing*, **92**, 468.
- BRISSART, R., BRÄUNINGER, U., HAYDON, S., MORAND, R., PALMER, G., SAUVAGE, R. and SEWARD, B. (2000) *European Brewery Convention Manual of Good Practice. Malting Technology*. Fachverlag Hans Carl. Nürnberg. 224 pp.
- BROOKES, P. A. and PHILLISKIRK, G. (1987) *Proc. 21st Congr. Eur. Brew. Conv., Madrid*. p. 337.
- BUCKEE, G. K. (1997) *J. Inst. Brewing*, **103**, 115.
- BYRNE, H. (1991) *Brew. Distill. Internat.*, **22**(11), 24.
- BYRNE, H. and LETTERS, R. (1992) *Proc. 22nd Conv. Inst. Brewing (Australia & New Zealand Sect.)*, Melbourne, p. 125.
- BYRNE, H., DONNELLY, M. F. and CARROLL, M. B. (1993) *Proc. 4th Sci. Tech. Conf. Inst. Brewing (Central & Southern Africa Sect.)*, p. 13.
- CHANDRA, S., BOOER, C., PROUDLOVE, M. and JUPP, D. (1999) *Proc. 27th Congr. Eur. Brew. Conv., Cannes*. p. 501.
- COMLINE, P. (1999) *Brew. Distill. Internat. Sept.*, p. 14.
- COPESTAKE, C. (1998) *The Brewer*, Feb., p. 79.
- DALE, C. J., YOUNG, T. W. and MAKINDE, A. (1989) *J. Inst. Brewing*, **95**, 157.
- DONHAUSER, S., WEIDENEDER, A. and GEIGER, E. (1991) *Brauwelt Internat.*, **141**, (4), 294.
- GIBSON, G. (1989) in *Cereal Science & Technology* (Palmer, G. H. ed.). p. 279. The University Press, Aberdeen.
- GODFREY, T. and REICHEL, J. (eds) (1983) *Industrial Enzymology. The application of enzymes in industry*. Macmillan, Basingstoke. 582pp.
- GRETENHART, K. E. (1997) *MBAA Tech. Quart.*, **34**(2), 102.
- GROMUS, J. (1988) *Brauwelt Internat.*, (II), 150.
- HAIKARA, A., ULJAS, H. and SUURNÄKKI, A. (1993) *Proc. 24th Congr. Eur. Brew. Conv., Oslo*. p. 163.
- HYDE, W. R. and BROOKES, P. A. (1978) *J. Inst. Brewing*, **84**, 167.
- JOHNSON, L. A. (1991) in *Handbook of Cereal Science & Technology* (Lorenz, K. J. and Kulp, K. eds). Marcel Dekker, New York. p. 55.
- KUNZE, W. (1996) *Technology Malting and Brewing*. (Internat. ed., Wainwright, T. transl.). VLB, Berlin. 726 pp.
- LAITILA, A., SCHMEDDING, D., VAN GESTEL, M., VLEGELS, P. and HAIKARA, A. (1999) *Proc. 27th Congr. Eur. Brew. Conv., Cannes*, p. 559.
- LAWS, D. R. J., BAXTER, E. D. and CRESCENZI, A. M. (1986) *European Brewery Convention Monograph- XI. E. B. C.-Symposium on Wort Production, Maffliers*, p. 14.
- LETTERS, R. (1990) *Louvain Brewing Letters*, **4**(3/4) 12.
- LLOYD, W. J. W. (1986) *J. Inst. Brewing*, **92**, 336.
- LLOYD, W. J. W. (1988a) *Brewer*, **74** (882), 147.
- LLOYD, W. J. W. (1988b) *Brewers' Guard.*, **47**, (5), 23.
- MARTIN, P. A. (1978) *Brewers' Guard.*, Aug., p. 29.
- MATSER, A. M. and STEENEKEN, P. A. (1998) *Cereal Chem.*, **75**(3), 189.
- MAULE, A. P. (1998) *Ferment*, **11** (1), 23.
- NARZISS, L. (1976) *Die Bierbrauerei. Vol. I. Die Technologie der Malzbereitung*. (6th edn). Ferdinand Enke Verlag, Stuttgart. 382 pp.
- NARZISS, L. (1991) *Brauwelt Internat.*, (4), 284.
- NARZISS, L. (1992) *Die Bierbrauerei, Vol. II. Die Technologie der Würzebereitung*. (7th edn). Ferdinand Enke Verlag, Stuttgart. 402 pp.
- REICHEL, J. R. (1983) in *Industrial Enzymology. The application of enzymes in industry*, (Godfrey, T. and

- Reichelt, J. R. eds), Macmillan, Basingstoke.
- RIESE, J. C. (1997) *MBAA Tech Quart.*, **34**(2), 91.
- ROBINSON, N., AMANO, H. and MIZUNO, A. (2001) *Eur. Brew. Conv. Monograph no. 31. Symposium on flavour and flavour stability*.
- SCHWARZ, P. B., JONES, B. L. and STEFFENSON, B. J. (2002) *J. Amer. Soc. Brew. Chem.*, **60**(3), 130.
- SEWARD, B. J. (1992) *Ferment*, **5**(4), 275.
- SOLE, S. M. (2000) *Ferment*, **13**(4), 25.
- SOUTH, J. B. (1992) *MBAA Tech. Quart.*, **29**, 20.
- STARS, A. C., SOUTH, J. B. and SMITH, N. A. (1993) *Proc. 24th Congr. Eur. Brew. Conv., Oslo*, p. 103.
- STOWELL, K. C. (1985) *Proc. 20th Congr. Eur. Brew. Conv., Helsinki*, p. 507.
- TAYLOR, D. G. and BOXALL, J. (1999) *Ferment*, **12**(6), 18.
- TENG, J., STUBITS, M. and LIN, E. (1983) *Proc. 19th Congr. Eur. Brew. Conv., London*, p. 47.
- VAAG, P., RIIS, P., KNUDSEN, A.-D., PEDERSEN, S. and MEILING, E. (1993) *Proc. 24th Congr. Eur. Brew. Conv., Oslo*, p. 155.
- WAINWRIGHT, T. (2003) *Brewers' Guard.*, **132**(2), 20.
- WALKER, M. D., BOURNE, D. T. and WENN, R. V. (1997) *Proc. 26th Congr. Eur. Brew. Conv., Maastricht*, p. 191.
- WALKER, M. D. and WESTWOOD, K. T. (1991) *J. Amer. Soc. Brew. Chem.*, **50**, 4.
- WEBSTER, R. D. J. (1981) *J. Inst. Brewing*, **87**, 52.
- WIEG, A. J. (1973) *MBAA Tech. Quart.*, **10**(2), 7.
- WIEG, A. J. (1987) in *Brewing Science, Vol. 3.* (Pollock, J. R. A. ed.). p. 533. Academic Press, London.

3

Water, effluents and wastes

3.1 Introduction

Breweries use large amounts of water, ('liquor' in the UK). The actual amounts of water used ranging from three to (exceptionally) 30 times the volumes of beer produced. As beers usually have water contents of 91–98% (or even 89% in the cases of barley wines), and the amounts lost by evaporation and with by-products are relatively small it follows that large volumes of waste water are produced. Sometimes large volumes are produced because of operational inefficiencies but breweries operating in efficient but different ways, and with different product ranges, have substantially different water requirements. Apart from brewing, sparging and dilution liquors, water is used for a range of other purposes. These include cleaning the plant using manual or cleaning-in-place (CIP) systems, cooling, heating (either as hot water or after conversion into steam in a boiler), water to occupy the lines before and after running beer through them, for loading filter aids such as kieselguhr, for washing yeast and for slurring and conveying away wastes as well as for washing beer containers such as tankers, kegs, casks and returnable bottles. The acquisition and treatment of liquor and the disposal of the brewery effluents are expensive processes and have long been studied.

While water is the major component of beer the brewery takes in many other materials such as bottles and other packaging materials, malts, adjuncts and hops, and during the brewing and packaging processes 'pollutants' and 'wastes' are generated. These include broken glass, damaged cans, packaging materials such as cardboard and plastic, spent grains, spent hops, trub, tank bottoms, carbon dioxide, spilled or spoilt beer, wort, noise, odours, domestic wastes and heat. All these must be dealt with and, where possible, disposed of at a profit. This chapter is primarily concerned with the acquisition and preparation of water of the grades needed in the brewery and the disposal of the dirty water, or effluents. However, the treatments or actions needed to deal with some other wastes or by-products are discussed (Anon., 1988; Armitt, 1981; Bak *et al.*, 2001; Benson *et al.*, 1997; Comrie, 1967; Crispin, 1996; Eden, 1987; Eumann, 1999; Grant, 1995; Hackstaff, 1978; Harrison *et al.*, 1963; Hartemann, 1988; Heron, 1989; Mailer *et al.*, 1989; Moll, 1979, 1995; Taylor, 1989; Theaker, 1988).

3.2 Sources of water

The sources of available water can be understood with reference to the water cycle. Water evaporates from the land, plants, fresh water and the sea. In time this forms clouds and precipitates as rain, snow or hail, falling back onto the land or into the sea. Of that falling onto the land a proportion evaporates, some runs off as surface water and some penetrates into the soil. The surface water may be collected in lakes, rivers or behind dams and so be available for use. Water from these sources is variously contaminated. Even rain-water is not pure, as it contains oxides of nitrogen and sulphur, dust, soot, pollen, microbes and industrial wastes. Collected on the ground it may be further contaminated with industrial and domestic effluents, spillages, drainings from dumps, rotting plant materials, farm animal wastes, leached agricultural materials (fertilizers, pesticides, and herbicides) and so on. The water which penetrates the soil is progressively filtered as it sinks downwards and so contains less of some surface-derived contaminants and micro-organisms. On the other hand salts may be dissolved from the pervious strata through which it passes. Thus surface waters will be comparatively 'soft', i.e., will contain little in the way of dissolved salts, in contrast to waters recovered from underground, which may be either 'soft' or 'hard'. Water which passes through chalk or limestone becomes enriched with calcium bicarbonate, while in other areas it may contain calcium sulphate or salt. When the water meets an impervious layer the pervious layers above become saturated with water and are called aquifers. Water can be drawn from some of these. Near the sea the soil may be saturated with brine, with less dense fresh water layered above. In these areas fresh water must be withdrawn only slowly or the saline water table may be drawn up and brine will enter the well. Waters with very different characteristics may be available within one area (Rudin, 1976).

Historically, different regions became famous for particular types of beer and in part these beer types were defined by the waters available for brewing (Table 3.1). Thus Pilsen, famous for very pale and delicate lagers has, like Melbourne, very soft water. Burton-on-Trent, with its extremely hard water, rich in calcium sulphate, is famous for its pale ales while Munich is well-known for its dark lagers, and Dublin (which has similar soft water) for its stouts. Breweries may receive water from different sources, which may be changed without warning. Water supplies may vary in their salt contents between day and night, from year to year and between seasons (Rudin, 1976; Byrne, 1990). It is now usual for breweries to adjust the composition of the water they use. In some few regions of the world saline water must be used, even sea water. In principle, several desalination methods might be used, but in practice it seems that purified water is obtained from sea water either by a highly thermally efficient distillation (Briggs *et al.*, 1981), which is very costly, or by reverse osmosis (see below). Usually breweries obtain their water either from their own wells, springs or boreholes (surface waters are avoided where possible) or they may obtain them from water companies.

Boreholes may extend downwards for 200 m (approx. 656 ft.), or more, and be fitted with an immersed pump to drive the water to the surface (Bak *et al.*, 2001; Kunze, 1996). Water is drawn from an aquifer via a filter. A bore is sealed to prevent surface water or water from upper soil levels rapidly leaking down to the aquifer being used. While water from water companies is typically of a high standard of purity and is 'potable', that is, it is fit for domestic use and is safe to drink, it is costly and is not necessarily fit to use in brewing (Baxter and Hughes, 2001). In addition, its composition and temperature are likely to vary and limits may be set on its use. Brewers' own water supplies will be more uniform, and will be substantially cheaper. However, there are likely to be charges for the

right to abstract the water and the volumes and rates of abstraction will probably be limited to avoid exhausting the available ground water or seriously disturbing the water table.

Most regions have strict regulations, which must be met before water is classified as being potable, and these provide the *minimum* standards for brewing waters (Armitt, 1981; Bak *et al.*, 2001; Baxter and Hughes, 2001; Moll, 1979, 1995). These regulations are often reviewed, the upper permitted limits for specified substances are frequently reduced and the numbers of substances mentioned are increased. Table 3.2 indicates how complex these 'minimum standards' can be. The requirements may be grouped as 'aesthetic' (colour, turbidity, odour and taste), microbiological standards (particularly the absence of pathogens), the levels of organic and inorganic materials that are in solution and the presence of radioactive materials. Some of these standards require comment. Drinking water must be safe, and so it must contain no pathogenic bacteria, protozoa, or viruses. However, the water is not necessarily sterile and so free of any organisms that can infect wort or beer, which must be the case for brewing water. The limits set for dissolved salts may be exceeded in some brewing waters. For example in Burton-on-Trent well waters the levels of calcium and sulphate ions may be very high (Table 3.1). Limitations on ammonia/ammonium and nitrogen levels are set since these are often indicators of contamination with decomposing organic matter. Nitrate levels, which vary widely, are a cause of concern as water sources are increasingly contaminated by nitrate from leached agricultural fertilizers. The fear is that during the preparation of the beer or in the consumer the nitrate may be reduced to nitrite (also limited, Table 3.2) and this, in turn, may give rise to carcinogens. The need to limit amounts of toxic ions is obvious although yeast needs trace amounts of many of them including copper, zinc, manganese and iron. These trace elements can be obtained from the brewers' grist. The minimum levels for total hardness and alkalinity are set to limit corrosion in pipework. Fluoride is often added to drinking water, but at the levels used it is harmless and without influence on fermentation.

The organic contaminants mentioned (Table 3.2) deserve comment. Acrylamide, vinyl chloride and epichlorohydrin are toxic substances used in the manufacture of organic polymers and their presence indicates that unsafe disposal practices have been used. Aldrin, dieldrin, heptachlor and heptachlor epoxide are insecticides or their metabolites. In other countries limits on other substances, including selective herbicides such as 2, 4-D (2, 4-dichloro phenoxyacetic acid) and diquat may be specified. Some of the polycyclic aromatic hydrocarbons are carcinogenic and the trihalomethanes confer unwanted flavours and may be toxic. The trihalomethanes, THMs, are unfortunately named since the organic substances in this group are not all based on the methane carbon skeleton and not all are tri-substituted with halogens. Chlorine and bromine are the usual halogen substitutes (Cowan and Westhuysen, 1999; Grant, 1995; McGarrity, 1990; Taylor, 1989). THMs may be industrial solvent residues or they can arise from organic materials in the water when this is sterilized by chlorination. Thus they can be formed during water treatment in the brewery.

Organic materials are particularly likely to be present in surface waters and may be dissolved or present as colloidal or suspended materials. Humic and fulvic acids are crude mixtures of organic materials with molecular weight ranges of 500–2,000,000 and 200–1,000 respectively. These are particularly likely to give rise to THMs during chlorination. The bromine substituents can be added when the chlorinated water contains bromide ions. The composition of the THM group varies. It includes chloroform, bromomethane, carbon tetrachloride, 1, 1-dichloroethane, 1, 1, 2-trichloroethane and

Table 3.1 Analyses of some waters from famous brewing centres, (expressed as mg/l). The analyses of these, or any waters do not remain constant with time (Moll, 1995; Mailer *et al.*, 1989)

Parameter	Pilsen	Burton-on-Trent	München (Munich)	Dortmund	London	Wien (Vienna)	Melbourne		
Total dry solids	51	–	1226	536	273	984	320	984	25
Calcium (Ca ²⁺)	7.1	352	268	109	80	237	90	163	1.3
Magnesium (Mg ²⁺)	3.4	24	62	21	19	26	4	68	0.8
Bicarbonate (HCO ₃ ⁻)	14	320	–	171	–	174	–	243	–
Carbonate (CO ₃ ²⁻)	–	–	141	–	164	–	123	–	3.6
Sulphate (SO ₄ ²⁻)	4.8	820	638	7.9	5	318	58	216	0.9
Nitrate (NO ₃ ⁻)	tr.	18	31	53	3	46	3	tr.	0.2
Chloride (Cl ⁻)	5.0	16	36	36	1	53	18	39	6.5
Sodium (Na ⁺)	–	–	30	–	1	–	24	–	4.5

tr. = Traces.

– = Not given.

Table 3.2 A list of the maximum (minimum) concentrations of substances that may not be exceeded in drinking water in the UK in 2001 (courtesy of J. MacDonald). Compare Bak *et al.*, (2001); Baxter and Hughes (2001)

Parameter	Units	Concentration or value
Colour	mg/l (Pt/Co scale)	20
Turbidity	Formazin units	1
Odour	Dilution number	3 at 25 °C
Taste	Dilution number	3 at 25 °C
Temperature	°C	25
pH (limits)	pH units	6.5–10.0
Conductivity	$\mu\text{S}/\text{cm}$ at 20 °C	2500
Permanganate value	O ₂ , mg/l	5
Total organic carbon, TDC	C, mg/l	no significant increase
Total coliform bacteria	number/100 ml	0
Faecal coliform bacteria	number/100 ml	0
Faecal <i>Streptococci</i> , <i>Enterococci</i>	number/100 ml	0
<i>Clostridium perfringens</i>	number/100 ml	0
Sulphate reducing <i>Clostridia</i>	number/20 ml	≤ 1
Colony counts	number/ml at 25 or 37 °C	no significant increase
(In some regions tests are also carried out for Protozoa, such as <i>Cryptosporidium</i> and <i>Giardia</i>)		
Radioactivity (total indicative dose)	MSv/year	0.1
Tritium	Bq/l	100
Boron	B mg/l	1
Chloride	Cl, mg/l	250
Calcium	Ca, mg/l	250
Total hardness	Ca, mg/l	60 (minimum)
Alkalinity	HCO ₃ , mg/l	30 (minimum)
Sulphate	SO ₄ , mg/l	250
Magnesium	Mg, mg/l	50
Sodium	Na, mg/l	200
Potassium	K, mg/l	12
Dry residues (after 180 °C)	mg/l	1500
Nitrate	NO ₃ , mg/l	50
Nitrite	NO ₂ , mg/l	0.5
Ammonia, ammonium ions	NH ₄ , mg/l	0.5
Kjeldahl nitrogen	N, mg/l	1.0
Dissolved or emulsified hydrocarbons		
Mineral oils	$\mu\text{g}/\text{l}$	10
Benzene	$\mu\text{g}/\text{l}$	1
Phenols	C ₆ H ₅ OH, $\mu\text{g}/\text{l}$	0.5
Surfactants (detergents)	as lauryl sulphate, $\mu\text{g}/\text{l}$	200
Aluminium	Al, $\mu\text{g}/\text{l}$	200
Iron	Fe, $\mu\text{g}/\text{l}$	200
Manganese	Mn, $\mu\text{g}/\text{l}$	50
Copper	Cu, mg/l	2
Zinc	Zn, mg/l	5
Phosphate	P, mg/l	2.2
Fluoride	F, mg/l	1.5
Silver	Ag, $\mu\text{g}/\text{l}$	10
Arsenic	As, $\mu\text{g}/\text{l}$	10
Bromate	BrO ₃ , $\mu\text{g}/\text{l}$	10
Cadmium	Cd, $\mu\text{g}/\text{l}$	5
Cyanide	CN, $\mu\text{g}/\text{l}$	50
Chromium	Cr, $\mu\text{g}/\text{l}$	50

Table 3.2 Continued

Parameter	Units	Concentration or value.
Mercury	Hg, $\mu\text{g/l}$	1
Nickel	Ni, $\mu\text{g/l}$	20
Lead	Pb, $\mu\text{g/l}$ (will be reduced in 2013)	25
Antimony	Sb, $\mu\text{g/l}$	5
(Elsewhere limits are set on other substances, such as thallium, beryllium, uranium and asbestos)		
Acrylamide	$\mu\text{g/l}$	0.1
Vinyl chloride	$\mu\text{g/l}$	0.5
Epichlorohydrin	$\mu\text{g/l}$	0.1
Aldrin	$\mu\text{g/l}$	0.03
Dieldrin	$\mu\text{g/l}$	0.03
Heptachlor	$\mu\text{g/l}$	0.03
Heptachlorepoxyde	$\mu\text{g/l}$	0.03
Other pesticides	$\mu\text{g/l}$	0.1
Pesticides, total	$\mu\text{g/l}$	0.5
Polycyclic aromatic hydrocarbons*	$\mu\text{g/l}$	0.1
Benzo(a)-3,4-pyrene	ng/l	10
1,2-Dichloroethane	$\mu\text{g/l}$	3
Tetrachloromethane	$\mu\text{g/l}$	3
Trichloroethane	$\mu\text{g/l}$	10
Tetrachloroethane & trichloroethene	$\mu\text{g/l}$	10
Trihalomethanes, total [†]	$\mu\text{g/l}$	100
Substances extractable in chloroform	mg/l, dry residue	1

* Sum of individual concentrations of members of a list of substances benzo[b]fluoranthene, benzo[k]fluoranthene, benzo-11,12-fluoranthene, benzo[ghi]perylene and indeno-[1,2,3-cd]pyrene.

[†] Sum of chloroform, bromoform, dibromochloromethane and dibromodichloromethane.

tetrachloroethane together with a range of other substances. Some THMs are also VOCs, (volatile organic compounds). Their volatility is the basis of their partial or total removal during gas-stripping processes (as when removing carbon dioxide after dealkylation, or oxygen removal) or during mashing and in the copper boil. THMs are also removed by active carbon filtration and partly removed during reverse osmosis. Chlorination of aromatic, organic materials can give rise to other undesirable materials, including medicinally flavoured chlorophenols.

3.3 Preliminary water treatments

Most brewers find it necessary to treat the water coming into the brewery. The variety of substances that may occur in water is large, and different treatments are needed to deal with them (Fig. 3.1). Different waters require different treatments and brewers require grades of water treated in different ways depending on the uses to which it will be put. In some instances it may only be necessary to pre-treat the liquor, while in other cases extensive further treatment will be needed. Preliminary treatments may involve aeration, sedimentation (with or without the prior addition of coagulants and flocculating agents, which initially require vigorous stirring, followed by more gentle stirring to encourage the build up of flocs), flotation, filtration and sterilization. Some of these treatments may be used more than once (e.g. sterilization) during the preparation of liquors. Aeration with compressed air (with or without ozone) is used to oxidize ferrous ions to ferric

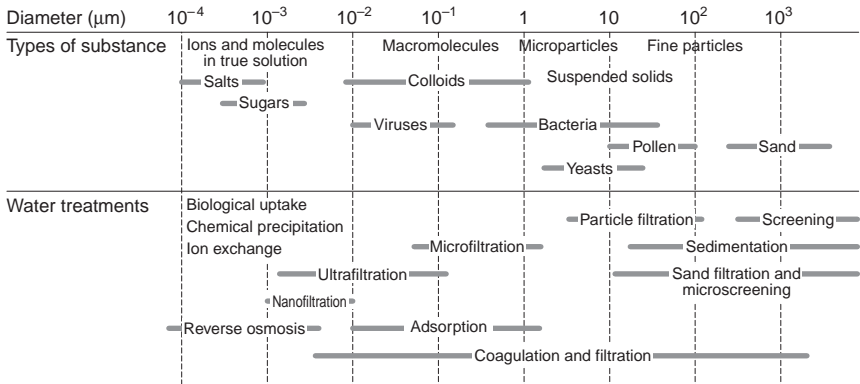

Fig. 3.1 The sizes of dissolved, colloidal and suspended materials that must be considered in water purification and the methods used in removing them (Bak *et al.*, 2001; Briggs *et al.*, 1981).

oxide/hydroxide (which separates from solution), to remove volatile organic substances, hydrogen sulphide, and carbon dioxide from water. Water is sprayed onto the top of a column filled with plastic packing, and flows downwards against a counter-current flow of air, which carries away the unwanted volatile substances.

Measured amounts of ferric chloride or aluminium sulphate, with or without some organic polyelectrolyte, may be added to water to act as coagulants. The salts hydrolyse, giving rise to voluminous precipitates of hydrated ferric hydroxide or aluminium hydroxide. After thorough mixing the precipitates are allowed to settle, carrying down inorganic and some organic suspended matter. The comparatively clear supernatant is removed, leaving the sludge to be collected and dumped. Untreated water may also have a sedimentation treatment to allow the denser suspended materials to settle, or it may be filtered. If the water is rich in dissolved iron or manganese these should be removed. Iron in particular can deposit oxides as slime which blocks pipes and can clog filters. In the brewing process iron ions give colours with polyphenols and, probably acting as oxidation catalysts, promote flavour and haze instability. Aeration or treatment with oxidizing agents, such as chlorine, converts ferrous ions to ferric ions which then separate as ferric hydroxide. Oxidizing agents are also needed to convert manganese to a precipitable form. Sedimentation or flotation are generally used before filtration. To achieve sedimentation the water is passed into a large tank in which it moves quietly and slowly to allow the solids to precipitate or the water may pass through lamellar separators, or centrifuges or hydrocyclones (Bak *et al.*, 2001). Alternatively, flocculated material may be removed by flotation in which finely divided bubbles of air rise from the base of a vessel and carry the flocs to the surface, where they accumulate and are removed by skimming.

Often suspended materials are removed from water by coarse filtration. It may be passed through a bed of sharp, calcined sand that may be 2–3 m (6.6–10 ft.) thick or it may pass through successive layers of granular plastic (3–5 mm), anthracite (2–3 mm) and sand (0.5–1.5 mm). When the filter becomes blocked, as signalled by a rising resistance to the water flow, it is back-flushed with a reverse stream of water to carry away the blocking particles. In special BIRM filters the sand is mixed with manganese dioxide, which catalyses the oxidation, and so the precipitation, of ferrous ions as ferric hydroxide. A newer device is the fibrous depth filter. Fibres are firmly twisted together around a support to form a tube, creating an efficient filter, which is able to exclude more

than 98% of particles over $2\ \mu\text{m}$ in diameter. To clean the filter the tension is reduced and the enlarged spaces between the fibres are cleaned with a back-wash. Cartridge filters, which exclude particles over $5\ \mu\text{m}$, may also be used.

Water in breweries may be sterilized more than once at different stages. Chemical sterilants are chlorine, hypochlorites, chlorine dioxide, ozone and, less often, silver. Physical sterilants used are exposure to ultraviolet light, sterilizing filtration and, rarely (except during the hop-boil), heat. Chlorine, used as the green-yellow gas or as sodium, potassium, or calcium hypochlorites, is a commonly used sterilant. One recommendation is that the level of available chlorine should initially be $5\ \text{mg/l}$ that the water should be held at least for 30 min., to allow the sterilant to act and at this time the level of free chlorine should not have fallen below $1\ \text{mg/l}$. This recommendation emphasizes that chlorine is a highly reactive compound and a strong oxidizing agent that is used up during water sterilization but that it remains in solution long enough to have a useful 'residual' sterilizing effect. Disadvantages of using chlorine include the formation of chlorophenols and THMs from organic substances in the water. Unwanted residual chlorine may be removed by aeration, evaporation, by filtration through active carbon, or by adding bisulphite or sulphite to the liquor, when the chlorine is reduced to chloride ions while the sulphite is oxidized to sulphate. If the water contains ferrous ions chlorine will oxidize them to ferric ions, which will then form flocculent ferric hydroxide.

Chlorine dioxide, ClO_2 , an unstable, yellow, explosive gas that is generated on site immediately before use, from hydrochloric acid and sodium chlorite:



It is a strong oxidizing agent. Unlike chlorine, it does not chlorinate organic substances and so does not give rise to THMs or unwanted flavour compounds. Indeed it destroys the off-flavours given by some chlorophenols. Its 'residuals' last for a shorter period than those of chlorine and so this agent is less effective at preventing re-infection. A contact time of 15 min. is desirable. Ozone, O_3 , is formed on site by passing dry air or oxygen through an electrical generator. This gas is a strong oxidizing agent, but its lifetime is short and so it gives almost no residual protection against re-infection. This agent is said to be more effective against *Giardia*, cysts of other protozoa and some viruses and bacteria than chlorine or chlorine dioxide. It is also effective at destroying some taints and odours. Treated water should initially contain $1\text{--}3\ \text{g ozone/m}^3$. Treatment should be extended from 3 to 15 min. and the higher doses should be used if iron and/or manganese ions are to be oxidized. Ozone is toxic and should be degraded before waste gases are vented to the atmosphere. Silver ions, generated by the electrolytic 'katadyn process' are also effective sterilants under some conditions but their use is not permitted everywhere and impurities in the water can reduce their effectiveness. All the sterilants mentioned must be handled with care, as they can be dangerous.

Sterilization with ultraviolet light, UV, relies on the fact that emissions at wavelengths around $260\ \text{nm}$ are absorbed by nucleic acids, which are then disrupted. Thus UV light from low-pressure mercury lamps is able to kill microbes, including viruses, but of course the treatment leaves no sterilizing residue. The long tubular lamps are housed in quartz tubes and the water flows past in a tubular metal housing which limits the length of the UV light path. The water must be clear and colourless and not give deposits to avoid blocking the UV radiation. The dwell time in the radiation chamber must be sufficient for sterilization to be complete. UV treatment of water containing dissolved ozone is more effective than either agent alone, and chlorinated hydrocarbons are fully oxidized, to carbon dioxide and

hydrochloric acid, and the COD of the water is reduced. The lamp tubes must be checked regularly and must be replaced as they approach the end of their working lives. Personnel must not be exposed to this radiation. Bacteria and fungi (but not viruses) can be removed by sterile filtration through special membranes (wound membranes or hollow fibres) having, for example, notional pore sizes of 0.2 or 0.45 μm . Such membranes can easily be blocked and so the water must be free of components that can deposit sludge or scale or contain fine suspended matter therefore the water to be sterilized must be pre-treated and carefully filtered. Pasteurization is rarely applied to water, but is used on some beers (Chapter 21). Other treatments, such as flocculation or reverse osmosis, deplete or remove microbes, but these processes are primarily used for other purposes.

3.4 Secondary water treatments

Water used in breweries is usually treated to adjust its composition (Bak *et al.*, 2001; Benson *et al.*, 1997; Blackmann, 1998; Comrie, 1967; Mailer *et al.*, 1989; Moll, 1995; Taylor, 1989). Treatments may reduce levels of organic compounds in solution or adjust the ionic composition of the liquor. In the past this subject was confused by widely differing methods of expressing salt concentrations (Moll, 1979,1995; Appendix). Here units of mg ion/l will be used. Ions in beer can influence its flavour (see below) and calcium ions in particular influence the mashing process (Chapter 4). Discussions of water composition often involve the term 'hardness'. 'Soft' water contains low concentrations of dissolved salts, particularly salts of calcium and (with less emphasis) salts of magnesium. 'Hard' water contains high concentrations of salts, usually mainly calcium bicarbonate or calcium sulphate. 'Temporary hardness' is caused chiefly by calcium bicarbonate and is so-called because if the water is boiled the bicarbonate is converted to the carbonate, which precipitates leaving the clarified water 'softened'. In contrast 'permanent hardness' is mainly caused by calcium sulphate, and this remains in solution when the water is boiled. The distinction is important if the liquor is to be used for mashing or, even more, for sparging.

While temporary hardness can be removed by boiling water, this process is costly and is usually avoided although it may be beneficial in other ways, such as sterilizing the water, driving out the dissolved oxygen and evaporating volatile contaminants such as THMs. The decomposition of the bicarbonate occurs as:



Magnesium bicarbonate is also decomposed by boiling, but magnesium carbonate is appreciably soluble, and so its removal is incomplete. The calcium carbonate precipitates and the carbon dioxide is driven off. Boiling also accelerates the oxidation of ferrous ions to ferric ions, which precipitate as the hydroxide. Treatments with lime water may be used to remove temporary hardness from water. A calculated amount of lime-water, or a slurry of lime in water, is mixed with the water. Calcium carbonate is precipitated:

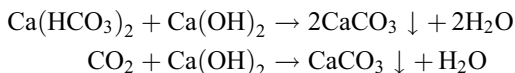

In older plant the precipitate of calcium carbonate settles slowly, but in a more modern and fully automated plant the calcium carbonate is deposited on crystalline granules of the same material 0.1–2.5 mm in diameter. In either case residual suspended calcium carbonate is removed, for example by sand filtration. The calcium carbonate is used in

agriculture, spread on fields to reduce soil acidity. After the lime treatment the water is alkaline and, for brewing purposes, must be adjusted to about pH 7. In Germany, and elsewhere where the use of mineral acids is forbidden, this is achieved by adding carbon dioxide. However, where it is permitted, the alkalinity is reduced by additions of food grade acids, commonly mineral acids but sometimes lactic acid. When the water contains an appreciable amount of magnesium bicarbonate it may receive a 'split treatment'. A portion of the water is dosed with a high level of lime. Calcium carbonate precipitates and magnesium precipitates as the hydroxide:



This partly treated water is strongly alkaline, with a pH of about 12. It is mixed with the remainder of the water (about two-thirds of the amount being treated), precipitating the calcium bicarbonate as the carbonate. After clarification the pH of the water is adjusted. Thus calcium bicarbonate and some of the magnesium salts are removed. Both the lime water treatments also precipitate iron and manganese ions, as hydroxides, and the precipitates entrain and remove some organic contaminants. Another way of removing bicarbonate ions from solution is to acidify the water and then remove the carbon dioxide formed with aeration. Thus:

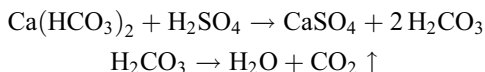

The food-grade acid used depends on flavour, safety and operational considerations. After acidification the water is passed down a packed tower against an upward stream of air that carries away the carbon dioxide. Incidentally, it also removes some volatile organic compounds and chlorine, if these are present.

Several types of ion exchange treatments may be applied to brewing waters. Modern ion exchange resins are now used rather than the old mineral ion exchangers, such as zeolites. The resins are beads of varying porosities, often of cross-linked polystyrene, which carry acidic or basic groups. Ion exchange treatments may be fully automated. Resins must be free of flavoured, low molecular weight organic materials, and they must not be exposed to chlorine, which will attack them. Iron and manganese must have been removed from the feed water and this is carefully filtered to prevent the resin beds becoming blocked. The costs of ion exchange treatments include the costs of regenerating the resins and of disposing of the regeneration liquid chemical wastes. The treatments may be divided into dealkalization, softening and demineralization. In dealkalization, which removes temporary hardness, the water is passed through a packed column of a weakly acidic cation exchange resin, which carries carboxylic acid groups. This resin exchanges hydrogen ions for calcium and magnesium ions in the water. The hydrogen ions combine with bicarbonate ions in the water forming carbonic acid and this then dissociates reversibly to carbon dioxide and water:

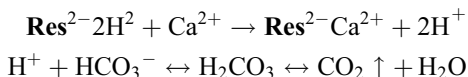

The water is then passed down an aeration tower where the carbon dioxide is removed together with some volatile organic compounds, VOCs, and chlorine.

After ion exchange treatment water is often passed through active carbon filters as a precaution to remove any unwanted off-flavoured compounds that may be released from

the resins. In time the exchange capacity of the resin is exhausted and it has to be regenerated. Both the resin and the acid used to regenerate it are comparatively inexpensive and indeed this treatment may be used before demineralization to reduce the cost of this latter process. The waste regeneration liquid is acidic. Water softening can be carried out by adding sodium carbonate to water containing, for example, calcium sulphate. Calcium carbonate precipitates leaving the more soluble sodium sulphate in solution. More often softening is carried out by ion exchange. A strongly acidic ion exchange resin, carrying sulphonic acid groups, is loaded with sodium ions. When the water passes through the resin this exchanges sodium ions for the more strongly bound divalent metal ions, like those of calcium and magnesium. The softened water is used where the use of hard water might give rise to scales and deposits of sludge, for example in cooling water, in boilers and in rinsing water.

Demineralization involves treating the water with strongly acidic and strongly basic resins loaded with hydrogen and hydroxyl ions respectively. The water may go through two resin beds working in series or mixed bed resins may be used. Aeration may be used, either after passage through the strongly acidic resin or after the entire treatment, to remove liberated carbon dioxide. Mixed bed resins are returned to the makers for regeneration. Using this system all the positively charged ions in the water are exchanged for hydrogen ions and all the negatively charged ions are exchanged for hydroxyl ions. For example:

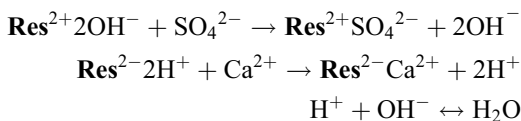

The hydrogen and hydroxyl ions combine to give water. Demineralization can give very pure water. Very strong basic resins can even remove silicate ions and some organic acids and the resins can at least partly remove some herbicides and their breakdown products. Temporary and permanent hardnesses are removed and so are all ions, including nitrate. It is now commonplace for brewing water to be demineralized and then for the compositions of the process streams to be adjusted to meet the different process requirements. This is convenient, since fluctuations in the composition of the incoming water become irrelevant and different brewing liquors can be prepared as needed for different beers. The processes of demineralization and reverse osmosis are in direct competition. If the levels of the total dissolved salts are comparatively low (TDS < 1,000 mg/l) then demineralization is likely to be chosen, despite the cost of regenerating the resins. Typically some 10–15% of the incoming water is used in the regeneration processes and goes to waste.

Reverse osmosis (RO) is attractive if the water to be purified is high in total dissolved solids (> 1,000 mg/l; Benson *et al.*, 1997; Berkmortel, 1988a, 1988b; McGarrity, 1990; Thompson, 1995). There have been great advances in the technology of making membrane units either in the form of hollow fibres or as spirally wound sheets. The semi-permeable membranes used in reverse osmosis are permeable to water but they are impermeable to microbes, ions and organic substances of molecular weight > 200. If pure water is separated from a salt solution by a semi-permeable membrane (i.e. permeable to water but not to solutes) there is a net migration of water through the membrane into the salt solution. If the pressure on the salt solution is increased then at a particular value it can balance the osmotic pressure, the tendency of the water to migrate into the salt solution, and no net movement of water will occur. If the pressure on the salt solution is

increased still more water will be driven through the membrane from the salt solution, which is concentrated, and the permeate will be substantially pure water. High-pressure pumps are needed to drive this process. In an extreme case a pressure of 25 bar (367.5 psi) is needed to desalinate sea water with a TDS of 35,000 mg/l. This extreme degree of desalination may be carried out in two steps. The water under pressure flows across the membranes and about 75% is recovered as purified permeate and 25% as concentrated 'saline'. In many cases this 'saline water' is still of use for hosing down, etc.

In a less extreme case a feed water with a TDS of 1200 mg/l treated by reverse osmosis (RO) gave rise to a permeate with 1–8 mg/l TDS. RO plant has no regeneration costs and can be cleaned automatically (CIP). On the other hand many of the membranes must be protected from chlorine and, to prevent membrane blockages, the feed water must be free of suspended solids, manganese or iron salts or materials that can form scales or sludges. Therefore the water may need pre-treatment and it must be filtered, probably through a sand filter and then through a fine filter removing particles $> 10 \mu\text{m}$ diameter (Braun and Niefind, 1988). Filtration also protects the high-pressure pumps from damage by abrasive particles. As the salt concentration of the water increases so does the cost of treatment, but not to a proportional extent. Sets of membranes are expected to last about five years therefore a treatment could involve filtration through a BIRM filter, acidification, the removal of carbon dioxide in an aeration tower, very fine filtration and then RO. Reverse osmosis is now in widespread use. In contrast, electrodialysis, a competing technology, seems not to have found favour.

Brewing water is often passed through layers of active carbon. This 'carbon filtration' is used to remove residual chlorine, humic and fulvic acids, many aromatic organic substances, some pesticides, some THMs and phenolic substances, and unwanted coloured, flavoured and odorous materials. Charcoals from different sources differ in their adsorbitive capacities and the types of substances that they remove best (Gough, 1995). Bituminous coal, anthracite or coconut shells, as examples, are pyrolysed, giving products that are predominantly microcrystalline graphite. These are then 'activated' by one of several methods. The material chosen for use must have the correct particle sizes, be strong enough to resist some wear, be of a 'food grade', and have the correct adsorbitive characteristics. A charge for a filter should last for five to seven years. The liquor reaching the filter should be sterile and well filtered and have been treated so that it does not give deposits. With the passage of time the filter will tend to become blocked and a source of microbiological infection. In addition, its adsorbitive capacity will tend to become saturated and so the charcoal must be cleaned, sterilized and regenerated. As a routine, carbon filters are backwashed with chlorinated water and then drained and steamed. Sterilization of the liquor coming from a carbon filter must be by a technique that leaves no residues. Consequently UV radiation is often used or, less often, ozone.

Brewers are increasingly concerned to exclude air, or rather the oxygen in the air, from their beers and from the production stream. To help to achieve this several methods for deoxygenating water are in use (Andersson and Norman, 1997; Benson *et al.*, 1997; Cleather, 1992; Kunze, 1996). In some instances the carbon dioxide and/or nitrogen levels of the liquor are adjusted as the oxygen is removed. As the temperature of water rises so the amount of oxygen that it will hold in solution declines (Table A12 on page 844) therefore water can be at least partly deaerated by boiling or stripping with (clean) steam. This approach is costly. Another method is to heat the water to 85 °C (185 °F) or more and then spray it into a vacuum chamber to remove the dissolved gas. More than one treatment may be needed. Another approach is to saturate, under pressure, the water to be deoxygenated with carbon dioxide or nitrogen. The water is then transferred into a

low-pressure chamber when the gas bursts out of solution carrying the dissolved oxygen with it. The chamber may be ventilated with the carrier gas. Merely bubbling carbon dioxide or nitrogen through the water is not sufficient.

Several methods seem to be preferable to those described; water can be sprayed into the top of a tower packed with a plastic filler. As the water trickles down as a thin film it meets an upflow of the stripping gas, carbon dioxide or nitrogen. The stripping gas may be sterile filtered. The liquor loses its oxygen to the stripping gas, which removes it efficiently as the system works on the counter-current principle. An alternative approach is to pass the water across a hydrophobic but gas-permeable membrane (hollow fibre or spirally wound format. Brown *et al.*, 1999). The non-water side of the membrane may be a vacuum or a flowing stripping gas. The water loses its oxygen through the membrane. Several of the methods mentioned ensure that the water is saturated with the chosen carrier gas. Another method for reducing dissolved oxygen, DO, levels is its catalytic reduction with hydrogen. The DO level of a stream of flowing water is sensed and the appropriate amount of hydrogen is dosed into the water stream and is dissolved under pressure. After thorough mixing the water passes over a palladium catalyst (supported on beads of an ion exchange resin) and the oxygen is reduced to water. Using this technique the oxygen content of the water can be reduced to as little as 0.002 mgO₂/l. In some instances, e.g., in some boiler waters, sulphite salts may be added to react with, and so 'scavenge', oxygen. The sulphite is oxidized by the oxygen, becoming sulphate.

3.5 Grades of water used in breweries

The mixture of dissolved substances judged suitable in liquor used for mashing may differ from those present in sparge liquor or dilution liquor and will certainly differ from those preferred in cleaning or boiler waters. Mashing liquor may not be completely sterile, but its microbial count must be low. Increasingly, brewers employing newer types of plant will mash with oxygen-reduced or oxygen-free water and under conditions such that oxygen pick-up is minimal. The mixture of salts present in the liquor may have been supplemented or adjusted. The addition of calcium sulphate and/or chloride, 'Burtonization', is common and when demineralized or reverse osmosis processed water is used as the base all the salts present will have been added. The salts used and their concentrations are decided with reference to their functions in mashing (Ch. 4; cf. Table 3.1) and their flavours. To reduce the pH of a malt mash by 0.1 unit requires the addition of 300 g calcium sulphate or 250 g calcium chloride/100 kg malt, the salts being added in the brewing and sparging liquor (Comrie, 1967).

The flavours of chloride and sulphate ions are different. It is recommended that brewing liquors for Burton style pale ales should have a sulphate to chloride ratio of 2:1 to 3:1. For mild ales the concentration of calcium should be less and the ratio should be about 2:3, while liquor for stouts should contain little or no sulphate. Sparge liquors may resemble mashing liquors, but it is desirable that the bicarbonate levels are very low, otherwise there is an undesirable rise in the pH of the last runnings as the buffering substances are leached from the mash. Deaerated and sterile water is required for pre-run and chase water preceding and following beer through pipework and for carrying slurried kieselguhr when forming the pre-coat on filters. Water that is sterile, deoxygenated, correctly carbonated and has the correct ionic composition and pH is used to dilute 'high gravity' beers to their final strengths. Sterile water is also used to slurry and wash yeast. When water is to be heated during use, as in cooling water or in the pasteurizer, it needs to have been softened,

demineralized or otherwise treated to prevent the deposition of sludges and scale, which can cover surfaces and interfere with heat exchange and may even block pipework. In addition, carbon dioxide and oxygen should be removed to minimize corrosion and antimicrobial agents may be added. In some instances the pH of heating water is adjusted with phosphate salts and scale-softening agents, such as tannins, may be added.

While some high-pressure boilers require a supply of fully de-ionized, oxygen-free water, low-pressure boilers may operate with softened water sometimes dosed with chelating agents, such as EDTA or polyphosphates, to prevent the deposition of calcium salts on the heat-exchange surfaces (Ibbotson, 1986). Sludges are removed by 'blowing-down', that is, ejecting them from the boiler to waste. Water being cooled in cooling towers should be treated with biocides to check the build up of populations of undesirable organisms, including beer-spoilage organisms and *Legionella*. For cleaning in vessels, pipework, bottles, kegs, etc., the water used should be sterile and it may contain traces of sterilant (e.g. ClO₂). It must not leave deposits after draining. Water used for general cleaning, but that does not come into contact with the microbe-free surfaces that will contact wort or beer, can be of a lower quality and need not be sterile. Clearly, supplying liquors of the correct grades for different uses around a brewery can be a comparatively complex process. The objective must be to obtain supplies of the various grades as simply and inexpensively as possible. The ways in which this is achieved are very varied.

3.6 The effects of ions on the brewing process

Ions present in brewing water have a range of effects on the production process and the quality of the product (Bak *et al.*, 2001; Comrie, 1967; Moll, 1995; Taylor, 1981,1989). In this section the roles of major ions will be considered in turn. It will be understood that other ions are added to the process stream from the grist and from the hops. In addition solid salts may be added directly to the mash or to the wort. Calcium ions (Ca²⁺, at. wt. 40.08) serve several important functions in brewing. They stabilize the enzyme α -amylase during mashing and, by interacting with phosphate, phytate, peptides and proteins in the mash and during the copper boil, the pH values of the mash and the wort are usefully reduced. For example:



or

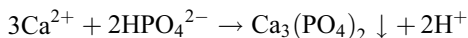

If bicarbonate ions are also present (the water has temporary hardness) these can more than offset the effect of calcium and cause a rise in pH (Chapter 4). Perhaps the concentration of calcium ions should not greatly exceed 100 mg/l in the mashing liquor as no great advantage is gained from higher doses and there is the risk that too much phosphate may be removed from the wort, and the yeast may then have an inadequate supply. Another recommendation is that calcium should be in the range 20–150 mg/l, depending on the beer being made.

Calcium oxalate, Ca(COO)₂, is deposited as beer stone during fermentations, and an adequate level of calcium ions ensures that the deposition is nearly complete. Crystals of calcium oxalate formed later in packaged beer provide nuclei for the breakout of carbon

dioxide and so can cause gushing and haze. In mashing the fall in pH caused by calcium ions favours proteolysis and so an increase in FAN, and faster saccharification. The more acid conditions also reduce wort colour, hop utilization and favour a reduction in astringent flavours. Calcium ions favour the formation of a good, flocculent hot break (trub) and yeast flocculation, but they seem to have little effect on flavour.

Magnesium ions (Mg^{2+} , at. wt. 24.32) are needed by many yeast enzymes, such as pyruvate decarboxylase. In some respects the effects of this ion resemble those of the calcium ion, but the effects on pH from interactions with phosphates are less pronounced, being about half, because the salts are more soluble. While high concentrations of magnesium ions are unusual, they can impart a sour or bitter flavour to beer. High, laxative concentrations are not reached. An upper limit of 30 mg magnesium ions/litre has been proposed.

Sodium ions (Na^+ , at. wt. 23.0) occur in some waters and sodium chloride is the main solute in saline waters. Sodium ions can impart sour/salty flavours at high concentrations (over about 150 mg/litre, which is also a proposed maximum concentration) and sodium chloride may be added to brewing liquors (75–150 mg/l) to enhance ‘palate-fullness’ and a certain sweetness. Sometimes potassium chloride is added instead, at low concentrations, to achieve a less sour flavour. Excess potassium ions (K^+ , at. wt. 39.1) > 10 mg/l) can have laxative effects and impart a salty taste.

Hydrogen ions (H^+ , at. wt. 1.01) and hydroxyl ions (OH^- , at. wt. 17.01) are always present in water, which is neutral when these ions are present in equimolecular amounts, $[\text{H}^+] = [\text{OH}^-]$. The negative \log_{10} of the hydrogen ion concentration, expressed in molarity, is the pH. As the temperature rises the dissociation of the water increases, the hydrogen ion concentration increases, and so the pH of water at neutrality declines (Table A8 on page 842).

Iron ions (Fe^{2+} , ferrous and Fe^{3+} , ferric; at. wt. 55.9) can occur in solution, for example, as ferrous bicarbonate or complexed with organic materials. Ferrous water is undesirable for brewing purposes, since it can deposit slimes (probably after oxidation, as red-brown hydrated ferric hydroxide), which can block pipes, filters, ion exchange columns, reverse osmosis equipment, etc. In addition, iron ions can confer dark colours to worts and beers by interacting with phenolic substances from the malt and hops and can convey metallic, astringent tastes to beers, give hazy worts and inhibit yeasts. The ions, possibly because of their ability to act as oxidation/reduction catalysts, favour haze formation and flavour instability. At concentrations of > 1 mg/l iron ions are harmful to yeasts. Perhaps concentrations should be reduced to less than 0.1 mg Fe/l. For all these reasons, and because of the difficulties that they can cause in some water treatments, it is usual to reduce the levels of dissolved iron early in a water treatment process.

Copper (Cu^{2+} , at. wt. 63.5) presented problems in brewing when vessels and pipework were made of copper but since these have come to be made of stainless steel there have been fewer problems with dissolved copper in breweries. Copper ions are toxic and mutagenic to yeasts, which accumulate them and develop ‘yeast weakness’. Another source of copper ions was the older, copper-based fungicides applied to hops. Copper ions are oxidation/reduction catalysts and their presence favours flavour instability and haze formation in beer. Brewing liquor should contain < 0.1 mg copper/litre.

Manganese (Mn^{2+} , manganous; Mn^{4+} , manganic; at. wt. 54.9) levels in brewing water should be low, (< 0.2 mg/litre or even < 0.05 mg/litre) but trace amounts of this element (and copper and iron) are needed by yeast. Like copper and iron these ions are oxidation/reduction catalysts and have adverse effects on flavour and beer colloidal stability. Manganese is less easily removed from water than iron.

Ammonia (NH_3 , m. wt. 17.03) and ammonium ions (NH_4^+ , m. wt. 18.04, $\text{pK}_a = 9.25$ at 25°C) occurs almost entirely as ammonium ions under brewing conditions. Ammonia in water indicates that the water may be contaminated with rotting organic matter and a proposed maximum concentration is 0.5 mg/litre. However, ammonia can escape from refrigeration equipment and this, very water-soluble, gas is toxic.

Zinc (Zn^{2+} , at. wt. 65.4), if present in appreciable amounts in brewing water, usually indicates that this ion has been picked up during transfer or storage. High concentrations in ground waters are unusual. At high levels this substance can be toxic, the upper permitted concentration in potable water is 5 mg/l (Table 3.2). High concentrations are damaging to yeasts but small amounts are essential. Not infrequently the levels of zinc in worts are insufficient to maintain good fermentations and in these cases the worts may be supplemented with additions of zinc chloride (0.15–0.2 mg/l). The recommended range in brewing liquor is 0.15–0.5 mg/litre.

Bicarbonate (HCO_3^- , m. wt. 61.02) and carbonate ions (CO_3^{2-} , m. wt. 60.01). The stages of the ionization of carbonic acid, formed by the hydration of carbon dioxide, are:

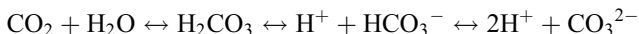

The pK_a values of the first and second dissociations, at 25°C , are 6.4 and 10.3 respectively. Thus at brewing pH values carbon dioxide is present as the gas, as carbonic acid and as the bicarbonate ion. High levels of bicarbonate ions in brewing water are undesirable since they cause unwanted increases in pH during mashing and sparging and in the hop-boil. Probably the concentration of bicarbonate ions in brewing liquor should never exceed 50 mg/l.

Sulphate ions (SO_4^{2-} , m. wt. 96.07); sulphate is the major counter ion to calcium and magnesium ions in permanently hard water. The ion contributes a drier, more bitter flavour to beers that should be balanced by appropriate amounts of chloride ions. Yeasts metabolize sulphate producing, *inter alia*, small amounts of hydrogen sulphide, (H_2S), sulphur dioxide, (SO_2), and other substances that contribute to the aromas of beers brewed with sulphate-rich water. The classic example is the 'Burton nose' of the ales brewed at Burton-upon-Trent. Acceptable sulphate concentrations are in the range 10–250 mg/litre.

Chloride ions (Cl^- , at. wt. 35.5) occur at high levels in saline waters. High levels are reported to limit yeast flocculation but to improve beer clarification and colloidal stability. Chloride ions contribute to the mellow, palate-full character of beer. The ratio of chloride to sulphate helps to regulate the saline/bitter character of beer. Ratios and concentrations for different types of beers have been proposed (see above; Comrie, 1967). A reasonable maximum concentration is 150 mg/litre.

Nitrate (NO_3^- , m. wt. 62.01) and nitrite ions (NO_2^- , m. wt. 46.01); there is concern about the rising levels of nitrate ions being found in ground waters. These ions are derived from agricultural fertilizers being leached from the topsoil and filtering down to the aquifers that supply water. Other sources are sewage and rotting organic matter. Even if the nitrogen is initially present as ammonium ions these are quickly oxidized to nitrate in the soil. Potable water usually has an upper limit of 50 mg nitrate/l and a limit of 0.1 or 0.5 mg nitrite/l, and these limits must not be exceeded in beers. However, brewers require lower levels in their brewing water since nitrate will be added to wort from the hops. The concern is that bacterial contaminants may reduce nitrate to nitrite. Nitrite ions can be toxic, they can give colours with tannins and, of most concern, can give rise to potentially carcinogenic nitrosamines.

Phosphate ions (e.g. HPO_4^{2-} , m. wt. 80.01); the stages of ionization of phosphoric acid are:



The pK_a values for the successive dissociations, at 25 °C, are 2.0–2.2, 6.7–6.8 and 12.4. Thus at mashing, wort and beer pH values, around pH5, most phosphate is present as the H_2PO_4^- ion. There are regulatory limits on the concentration of phosphate phosphorus that may be present in potable water, and a suggested maximum in brewing liquor is 1 mg/litre. Most of the phosphate in beer is derived from malt, although phosphoric acid or acid phosphate salts may be used to adjust the pH or to release carbon dioxide from bicarbonate-rich waters. Worts can also contain the organic phosphate phytate (salts of phytic acid), derived from malt. Phosphates are important pH buffers in brewing and interactions between calcium ions and phosphates, and other substances, usefully reduce the pH in mashing and during the hop-boil. Phosphoric acid is also used for acid-washing yeasts.

Silicate ions (e.g., SiO_3^{2-} , m. wt. 76.09); silica can dissolve to form a range of ions, with various silica to oxygen ratios. Reportedly high concentrations of silicates can damage yeasts and give rise to hazes in beers but if so, these events must be infrequent. The most significant effect of silicates is the deposition of scales, formed between silicate and calcium and magnesium ions, when the water is heated. An upper acceptable concentration of silicate may be 40 mg/litre.

Fluoride ions (F^- , at. wt. 19.00) occur in some ground waters. They rarely reach toxic levels. Potable waters have upper concentration limits of about 1.5 mg/litre. Small amounts of fluorides may be added to water for domestic use to reduce the incidence of dental caries. Even at substantially higher levels (10 mg F/litre) the ions are without perceptible effects on brewing.

3.7 Brewery effluents, wastes and by-products

Breweries generate wastes, by-products, pollutants and effluents (Armitt, 1981; Brooks *et al.*, 1972; Huige, 1994; Isaac, 1976; Isaac and Anderson, 1973; Klijnhout and Van Eerde, 1986; Meyer, 1973; Rostron, 1996). These must be dealt with in the least costly way or, in one or two instances, profitably. Into these categories come noise, heat, odours, dusts (from malt and adjuncts), cullet (broken glass), waste aluminium cans, plastic waste, domestic and laboratory wastes, carbon dioxide, trub, spent grains, spent grain drainings and pressings, surplus yeast, used kieselguhr from filters, waste beer, wort, waste water, boiler blow-down sludge, and acids, alkalis and detergents (from CIP and other cleaning systems), labels, lubricants, copper condensate, PVPP and ion exchange regeneration reagents, and so on. Dealing with these is expensive. Breweries generate large volumes of waste water, and most of the remainder of this chapter is concerned with its disposal. However, all wastes and by-products must be disposed of quickly in the interest of saving space and minimizing the risks of microbial contamination. Broadly, all wastes are either dumped or disposed of for recycling or sold or discharged into a sewer or a waterway or the sea. Once it was normal to wash as much waste as possible down a sewer. In many countries this is now too costly and so attempts are made to recycle materials, to minimize waste production, to 'add value' to by-products or at least to sell them and to partly or completely treat liquid wastes.

3.7.1 The characterization of waste water

Brewery waste water is chiefly contaminated with putrescible organic matter and so it is comparatively easily purified by biological treatments. However, the flow of waste water from a brewery varies greatly with the time of day, often with the day of the week and with the time of year. Worse, the water will vary widely in its temperature, pH, load of suspended solids and the amounts of organic and inorganic materials in solution. If the waste is being discharged to a public sewer the operating authority will usually set limits on the composition, volume, rate of flow, temperature and pH of the effluent, with swingeing penalties if the limits are exceeded. Evidently the detailed composition of the water is variable and very complex. However, for treatment purposes water analyses are simplified, and these analyses are adequate for charging for treatments and for deciding what the correct treatments should be (Armitt, 1981; Benson *et al.*, 1997; Briggs *et al.*, 1981).

Suspended, or settleable, solids, SS, are usually reported as mg dry matter/litre. Sometimes SS are defined as particles retained by a 1 μm filter. Their presence results in a reduced water clarity and they may deposit and create blockages or be abrasive and cause wear to pumps. Some may be partly destroyed or removed during biological treatments. Suspended solids which are not biodegradable usually finish as sludge in treatment plants. Total dissolved solids, TDS mg/litre, dissolved organic carbon, DOC mg/litre, and total organic carbon, TOC mg/litre are measures sometimes used but much more emphasis is placed on the biological oxygen demand, BOD, and the chemical oxygen demand, COD.

Because most older waste-water treatments were based on microbiological aerobic oxidations of dissolved organic matter, the biological, or biochemical, oxygen demand of the waste was of prime importance. The BOD_5^{20} is the weight of oxygen (mg) taken up as the organic substances in the water (1 litre) are oxidized by a mixture of micro-organisms in five days at 20 °C, in the dark. The test must be in darkness to prevent the growth of algae, which generate oxygen. This important test is slow and not very precise. In consequence it is increasingly being replaced with determinations of the chemical oxygen demand, COD. This is normally calculated from the amount of dichromate used up when the water is boiled with the acid reagent for two hours in the presence of a silver sulphate catalyst. The results are expressed as mg oxygen/litre water. However, as the dichromate oxidizes more substances than the microbes the COD values are greater than the BOD values. The ratios between these values vary widely, but for most mixed brewery wastes the COD/BOD ratio is 1.6–1.8. For domestic sewage the value is about 2.5. The permanganate value, PV, an alternative determination of oxidizable organic matter, is now used less.

In the UK the costs of having effluent treated in a municipal sewage works is usually calculated with reference to the 'Mogden Formula', (named after a London sewage works) or a modification of it.

$$C = R + V + (O_T/O_S \times B) + (S_T/S_S \times S)$$

Where C = the total charge/m³ (unit volume) for the trade effluent discharge. R = the cost of conveying and receiving the effluent + overhead costs. V = unit cost of volumetric and primary treatments (screening and settlement). O_T = COD of the trade effluent after settlement at pH7. O_S = COD of the average settled sewage and trade effluent (i.e. a reference strength). B = the unit cost of the biological treatment of the mixed and settled trade effluent and sewage. S_T = total suspended solids (SS) of the

mixed trade effluent. S_S = The SS of the mixture of the sewage and trade effluent, (standard strength). S = the unit cost of the treatment and disposal, of the sludge. Thus increases of COD, SS or volume lead to greater charges.

Extra charges will be made for effluents discharged outside stipulated 'consent limits', such as peak volume flows, pH or temperature values, COD, SS, soluble nitrogen, and so on. The actual charges made vary from place to place and are continuing to rise, pressurizing brewers to find ways of reducing these costs. Using particular examples, with 1987 figures, Table 3.3 illustrates how increasing water usage, and the inevitable extra effluent production, can be very expensive. Examples of reported ranges of BOD (mg/litre) are beers, 60,000–120,000; spent grain press liquor, 60,000; waste yeast with entrained beer, 200,000; trub, 70,000; spent kieselguhr, 80,000; fermenter washings, 20,000–30,000. Suspended solids, SS, represent 12–23% of brewery effluent BOD (Armitt, 1981; Benson *et al.*, 1997). Examples of the average characteristics of brewery waste water are: BOD₅(mg/litre), 400–1750 (900–2000); mean COD(mg/litre), 1200–3,000; BOD₅(kg/hl product), 0.45–0.95; SS(mg/litre), 93–772; SS (kg/hl product), 0.17–0.40; pH 4.1–11.5; temperature 13–49°C (55.4–120.2°F), ratio of effluent volume produced/volume of beer produced, 4–33. Soluble nitrogen (mg/litre), 30–80; phosphorus (mg/litre), 10–30. However, shock discharges, in particular effluent flows may be pH 2–3 to 10–13 and BOD 170,000–500,000. These should be prevented from reaching the sewer (see below). A brewery making 10,000–30,000 barrels of beer/week may release in the effluent 2–5.6 t COD/day and 0.46–0.87 t SS/day.

Sometimes brewery effluent loads are expressed as population equivalents. Different equivalents may be used (Armitt, 1981). However, a brewery with an output of 10⁶ hl will produce about as much effluent as 50,000 people. The quality of treated water that may be discharged depends on whether this is to the sea, to an estuary, or to a river, and what the minimum dilution rate will be. Some suggested limits are COD, 127 mg/litre; BOD, 25 mg/litre; SS, 35 mg/litre; nitrogen, 10 mg/litre; phosphorus, 1 mg/litre. Exceeding these, or other appropriate limits, will risk causing algal blooms, or the overgrowth of

Table 3.3 Examples of calculated water and effluent costs, using mean UK Water Authority charges for 1987 (data of Askew, 1987). A brewery has an annual production of 1 × 10⁶ barrels (36 × 10⁶ imp. gal.; 1.637 10⁶ hl). With a water : product ratio of 8 : 1, an effluent product ratio of 5.5 : 1, a mean effluent BOD of 1000 mg/l, a mean COD of 1800 mg/l, and an effluent mean SS of 500 mg/l then the water demand p.a. is 288 × 10⁶ imp. gal., the effluent volume is 198 × 10⁶ imp. gal., the BOD load p.a. is 900 tonnes (t), the COD load p.a. is 1620 t/p.a. and the SS load is 450 t/p.a. Assuming different efficiencies of water usage the three examples show the variations in water and effluent costs

Measure	Case 1	Case 2	Case 3
Water: product ratio	8 : 1	9.23 : 1	12.9 : 1
Annual water consumption (m ³)	1.309 × 10 ⁶	1.51 × 10 ⁶	2.11 × 10 ⁶
Cost (p/m ³)	27.8	27.8	27.8
Cost (£/year)	363,902	419,780	586,580
Effluent: product ratio	5.5	6.43	9.7
Effluent volume (m ³)	900,000	1,052,180	1,587,270
Effluent COD (mg/l)	1,800	3,580	4,500
Effluent SS (mg/l)	500	291	400
Effluent cost (p/m ³)	43.52	62.85	77.95
Effluent cost (£/year)	391,680	661,295	1,237,277
Total water and effluent costs (£/year)	755,582	1,081,075	1,823,857

Since 1987 costs have risen to a considerable extent. At present (August, 2004) £1 = 1.48 Euros = \$ (USA) 1.80

microbes causing the receiving water to become anaerobic so killing all higher life forms. Clearly brewery wastes must be treated before discharge to waterways. The treatment may be carried out, in whole or in part, at the brewery or at a sewage works.

3.7.2 The characteristics of some brewery wastes and by-products

The immense range of ratios of water taken in to beer produced is chiefly due to different efficiencies of water use, although some breweries, e.g., those that bottle a high proportion of their beer in returnable bottles, (which must be cleaned), are at a disadvantage. To control waste it is necessary to meter the volume and composition of the effluent from every department and the brewery as a whole, to detect and prevent wasteful practices. To be of use effluent streams must be sampled in statistically valid ways. Time-proportional or volume-proportional sampling may be used. Apparently minor leaks, or leaving hoses running, or having CIP programmes operating with excessive water rinsing or without the re-use of final rinse liquor for the first rinse can cause substantial losses (Horrigan *et al.*, 1989). The pH of effluent may become extreme, for example, when alkaline cleaning liquids or PVPP or ion exchange regeneration liquors are released. Precautions should be taken to trap these liquors and release them slowly at a metered rate with the general effluent to dilute them to an acceptable level, or their pH values may have to be adjusted before release. It has been proposed that alkaline liquors should be neutralized with carbon dioxide from furnace gases or from the fermenters rather than with mineral acids.

Much effort has been spent in finding better ways of dealing with brewery by-products and wastes (Brooks *et al.*, 1972; Horrigan *et al.*, 1989; Huige, 1994; Penrose, 1985; Reed and Henderson, 1999/2000; Vriens *et al.*, 1986, 1990). Many breweries collect some of the carbon dioxide from the fermenters and use it to carbonate beer (Chapter 15). Others allow much of it to escape and yet others may use it to neutralize alkaline waste liquors. Furnace gases, which may also be used for neutralizing alkaline effluents, contain carbon dioxide and acid oxides of sulphur. Efforts are now made to save heat in breweries (re-use of cooling water, warming water by condensing vapours from the hop-boil, etc.), and so less heat escapes in effluents. In principle, heat could be withdrawn from effluents using heat pumps, but probably this is not economic. It has been suggested that warm, clean water from a brewery might be used in a fish farm. Trub (hot break) and spent hops usually contain some wort. If washed into the sewer they add substantially to the BOD and SS. Normally the entrained wort is recovered, for example, by adding the trub and spent hops to the lauter tun. Alternatively, the spent hops and trub may be added directly to the spent grains. Some 30% of the trub solids are digestible proteins that add to the feed value of the spent grains. Spent hops have been used as a mulch or as low-grade fertilizer.

Sometimes trub is mixed with surplus yeast intended for animal feed. Surplus yeast is collected from fermenters, and is also present in tank bottoms. It can add substantially to the BOD and SS of effluents and, with a crude protein content of about 47% d.m., a carbohydrate content of 43% d.m., and a mixture of vitamins surplus yeast is potentially a valuable by-product. Often it is sold to companies that debitter it and turn it into food supplements (Putman, 2001). Surplus brewing yeast is used by distillers. On a comparatively small scale the yeast may be used as a source of biochemicals, particular proteins, enzymes and glutathione, and yeast extracts are used in culture media for microbes. Yeast tablets are used as vitamin supplements. Sometimes the yeast cake is washed and the yeast is returned to the production stream by adding it into the mash. Alternatively, it may be autolysed and then added to the spent grains to enhance their

value as animal feed. Malt dust has been added to mashes or has been mixed in with spent grains.

Used kieselguhr, from beer filters, used to be flushed into the sewers, but its large contribution to SS and BODs makes this undesirable and probably most is dumped, with or without first mixing it with quick-lime, at landfill sites. Small amounts have been used as a soil improver. Sometimes the used filter-aid has been mixed with the spent grains, but this is not always acceptable. Dumping is becoming costly and other disposal methods are being tested. Filter aid has been regenerated by chemical cleaning and by calcining to burn away organic residues. The regenerated material has been used again as a filter aid, as a fertilizer carrier, and as a filler in paints and varnishes.

'Waste' beer or wort may include last runnings from the mash, press-liquor from the spent grains, rinsings from vessels or pipework, returned beer, spillages from bottling and canning plants and rinsings from returned containers. All these residues may (expensively) be consigned to the sewer. Some brewers believe that returning last runnings and liquor from the spent grains to the mash constitutes a risk to the quality of the beer. Others have used these materials after clarification by centrifugation, with or without treatment with active charcoal, and keeping them for not more than two to three hours at 80°C before adding them to the mashing liquor or to the copper (Coors and Jangaard, 1975). In these instances no deterioration of beer quality was detected. Returned beer may be blended or discarded. Returned beer and weak worts have been used to make alcohol or vinegar, to grow other microbes, such as fodder yeasts (*Torula spp.*, *Candida spp.*, *Aspergillus spp.*), for use in foodstuffs. Yet others have dried the liquids. The product, dried brewers' solubles, has been added to foodstuffs. Probably most of these processes are not usually economically viable.

Spent grains are produced at the end of every mash. They are of value as a foodstuff, particularly for ruminants, but they are bulky, and they soon begin to decompose, so they must be removed from the brewery promptly. The handling equipment must be kept clean to prevent the growth of spoilage organisms. Depending on the grists their composition is variable. In one example the composition reported, on a dry weight basis, was crude protein, 27%; fat, 6–7%; ash, 4–5%; crude fibre, 15%; N-free extract, 46%. The moisture content of spent grains varies widely depending on the wort separation system used (Chapter 6). Thus grains from a Strainmaster may contain 87–90% moisture, and they are sloppy and are easy to pump, but they are so wet that liquid drains from them and they must be de-watered before removal. Water drains from grains with moisture contents above 80%. The drainings are an excellent medium for unwanted microbes. Grains from lauter tuns can contain 75–85% moisture and those from pressure filters contain as little as 50–55%. Exceptionally, these grains may be dried further in a current of hot air, to c. 8% moisture, when the dried material is stable. Grains may be sold for animal feed either wet or after de-watering. Using continuous screw or roller presses the moisture contents can be reduced to 63–72%, producing a more easily handled solid material and the squeeze liquor. The liquor may contain up to 3.5% dissolved solids and 5% SS as it has a high BOD. As it contains valuable extract it should be returned to the process stream, where possible. In one case this saved about 1% of brewer's extract and reduced water use by 5% (Coors and Jangaard, 1975).

The grains used for animal feed must be stored by farmers and the drier they are the easier they are to handle. Sometimes they are ensiled and additions of propionic acid or sorbic acid with phosphoric acid have been used to act as preservatives, and seeding with lactic acid bacteria has been proposed. As noted, autolysed yeast, trub, spent hops and even used kieselguhr may be added to spent grains. A range of other uses for spent grains

has been proposed, as a source of biogas and soil conditioner produced by anaerobic digestion, disposal by burning (giving heat), as a source of 'secondary worts' generated by acid or enzymic hydrolysis, as a source of protein, as a source of food-grade fibre, as a basis for mushroom compost, as a soil conditioner and organic fertilizer, as a medium for growing earthworms to use in poultry food, and in fish food. None of these alternative uses seems to be widely employed.

3.8 The disposal of brewery effluents

A consideration of the sources of brewhouse effluents shows that large volumes, BOD and SS are generated at different stages of the brewing process (Table 3.4; Askew, 1975, 1987; Askew and Rogers, 1997; Huige, 1994; Love, 1987; Robertson *et al.*, 1979). In some breweries all the 'waste' water is collected into a common sewer. However, it is senseless for surface run-off (storm water) to be directed to a treatment plant and clean, but warm water that has been used for cooling should find a use in the brewhouse for mashing or cleaning, both to minimize water and effluent charges and to conserve heat and so reduce heating costs. If the effluents are treated, in whole or in part, at the brewery then it is usually advisable to separate 'weak' and 'strong' effluents and to treat them separately. The costs of treating effluents in municipal sewage treatment works are high. Brewers try to minimize the volumes and strengths (BOD, COD, SS) of the effluents. Sometimes it is economical to partly, or even extensively, treat brewery effluents on site. Secondary treatment may allow the water to be discharged into a watercourse. If costs continue to rise it may become worthwhile to purify some effluents further, using tertiary treatments, so that the water is pure enough to be used again for some purposes in the brewhouse and so, by recycling, avoid acquisition and disposal costs. Usually effluent purification is undertaken with reluctance. Treatment plant takes up space, it is costly, and it requires well-trained staff to operate it successfully.

Whether effluents are treated at a brewery site or elsewhere the objectives are the same, to reduce the temperature to a moderate level (often under 40 °C, 104 °F), to restrict the pH to a specified range (e.g. 6–10) and to reduce the BOD, COD and SS levels to below specified levels (e.g. 25, 125 and 35 mg/l, respectively) so that the water can be released into a stream, river or estuary. Some breweries do not carry out any treatment on site, and there is no uniform system of treatment among the others. Historically, after preliminary screening, water was purified, using oxidative, aerobic biological systems. In recent years partial treatments using some anaerobic processes are being used. It is convenient to divide treatments into preliminary treatments, 'primary' treatments, 'secondary' treatments (aerobic, anaerobic or a combination of the two), and 'tertiary' or 'polishing treatments'.

3.8.1 Preliminary treatments

Many preliminary treatments are in use (Armitt, 1981; Benson *et al.*, 1997; Huige, 1994; Klijnhout and Van Eerde, 1986; Vereijken *et al.*, 1999; Vriens *et al.*, 1986, 1990; Walker, 1994). First the effluent should be screened to remove labels, bottle caps, floating plastic items and spent grains. These screens may be of many types, for instance, hyperbolic bar screens or screens of woven stainless steel mesh. It is desirable that the water also flows through a settling tank in which the reduction of the flow-rate permits culler, grit, sand and some SS to settle. The deposit formed is removed at intervals by scrapers, to be

Table 3.4 Estimated biological oxygen demand and suspended solids loads in a brewery employing yeast recovery (Robertson *et al.*, 1979)

Process	Flow		BOD		SS	
	(hl/day)	(gal/day)	(kg/day)	(lb/day)	(kg/day)	(lb/day)
Mash mixer	69.4	1526	3.6	8	7.3	16
Lauter tun*	68.0	1496	189.6	418	122.5	270
Brew kettle (copper)	97.2	2137	27.7	61	3.6	8
Hot wort tank (whirlpool)*	26.6	584	284.0	626	98.0	216
Wort cooler	24.1	531	0.5	1	0	0
Fermenters*	290.0	6386	240.4	530	155.1	342
Ageing tank (maturation)	407.7	8962	93.0	205	137.9	304
Primary filter*	81.9	1801	46.3	102	231.3	510
Secondary storage	385.1	8471	40.4	89	59.0	130
Secondary filter*	92.6	2037	8.2	18	42.2	93
Bottling tank	39.9	877	0.5	1	0	0
Filler	922.4	20291	23.1	51	9.5	27
Pasteurizer	3582.6	78808	34.5	76	3.2	7
Bottle washer*	2933.5	64529	68.0	150	29.0	64
Cooling water	4332.2	95298	0	0	0	0
Miscellaneous flows	92.2	2028	0.5	1	0.5	1

*Major sources of BOD and/or SS. Gal = imperial gallons. (1 imp. gal = 1.201 US gal = 4.546 litres).

dumped. Suspended kieselguhr and some yeast may be removed at this stage. The effluent may also pass through oil traps. The compositions, characteristics and flows of brewery effluents are highly variable and need to be 'evened out' if treatments are to be successful. Strongly acid or alkaline cleaning or regeneration solutions are sometimes released immediately into the effluent stream. It is better practice to hold these solutions in a special receiver to mix acidic and alkaline solutions and, perhaps after adjusting the pH, release them into the main flow of effluent over a period of time to dilute them to such an extent that they are harmless. Sometimes such material may be removed by a specialist contractor. An additional 'calamity tank' may be provided to hold sudden unexpected flows of liquid that can be released later, over a period, and so even out variations in the composition and flow rate of the effluent. All breweries, whether or not they treat their own effluents, should have a balancing or conditioning tank. This should be stirred and possibly be aerated to prevent the formation of odours. The size should be decided with reference to the brewery operations and should have a residence time (12 hours and 36 hours have been suggested, as well as much longer periods) selected to truly 'average out' effluent flow rate and composition, so that it will not be harmful to the microbes that carry out the next stage of treatment. The pH of the effluent may be adjusted automatically as it leaves this tank and if it is going to a biological treatment plant on site some microbial nutrients may be added at this stage.

Sometimes a different type of preliminary treatment may be carried out. For example, the effluent may be treated with a slurry of lime or another inorganic coagulant, and perhaps a synthetic polyelectrolyte. Then the mixture is given a flotation treatment. Air is dissolved in the effluent under pressure and this is directed into the base of the flotation vessel. The air separates as a cloud of fine bubbles and carries the coagulated materials up to the top of the vessel from which they are skimmed. In one case the removal of the SS was 96% and of the COD, 6% while in another instance the values were 60% and 45% respectively (Hughes, 1987; Lunney, 1981).

3.8.2 Aerobic treatments of brewery effluents

Many aerobic systems have been tried for treating brewery effluents and these are well understood (Armitt, 1981; Benson *et al.*, 1997; Klijnhout and Van Eerde, 1986; Kühtreiber and Laa-Thaya, 1995; Reed and Henderson, 1999/2000). The effluent, preferably of uniform composition and having the correct pH and levels of supplementary nutrients (nitrogen and phosphate), is aerated in the presence of 'sludge', a mixed population of micro-organisms. These multiply and grow. About 30% of the BOD-generating substances is oxidized to carbon dioxide and water, while the remainder is assimilated into microbial mass, the sludge. Surplus sludge is collected and must be disposed of. Sludge treatment and disposal is often the most difficult part of aerobic treatments. Broadly aerobic systems are operated in two different ways, although intermediate methods may be used. In the 'low load' methods, effluent 'lightly' loaded with BOD is supplied to a well-aerated mass of microbes and the contact time is extended. Under these conditions a type of sludge develops that is easy to handle and settles readily. BOD removal may exceed 98%. In 'high load' systems the ratio of BOD supplied/unit of biomass is high. BOD removal is less, for example 80%. A large mass of 'putrescible sludge' is formed. With effluents having high BOD values 'sludge bulking' occurs, involving the excessive growth of filamentous microbes that do not readily settle. This sludge is difficult to handle and de-water. This system is less resistant to 'shock loads' than the low load system.

From these considerations it can be concluded that for optimal treatments brewery effluents should pass through a buffering tank (or two tanks if the high BOD and low BOD effluents are to be treated separately), and effluents with high BODs should receive a preliminary treatment (aerobic or anaerobic; see below) before they are treated further in a 'low-load' system. Aerobic treatment systems are considered in two groups, the activated sludge systems in which the biomass is in suspension and systems in which at least most of the biomass is attached to a solid support.

Perhaps the 'single tank systems' are the most simple of those using activated sludge. In these effluent is progressively loaded into an aerated tank which already contains biomass which is mixed by the aeration process, usually achieved by blowing compressed air into the base of the tank through dispersers which release it as fine bubbles. When the tank is full the effluent is diverted to the next tank in line. Aeration is continued in the first tank until the BOD has been sufficiently reduced. Then aeration ceases and the active sludge is allowed to settle and the clear, treated effluent is drawn off from above the sludge. Any surplus sludge is removed, usually to a settling tank, and aeration is resumed and the tank is ready to begin receiving the next charge of effluent.

Where large areas of ground are available effluents may be treated in large lagoons. Usually two lagoons operate in series and, because they are large, they constitute a low-load system. The lagoons are aerated, preferably with bubbles rising from the bottom, (surface aerators are inefficient and can create microbe-laden aerosols) and each may be followed by a sludge-settling tank. Effluent then flows into a lagoon, is diluted and aerated. After an average holding period, it flows into a settling tank. The clarified effluent flows to the next lagoon or out of the system while a proportion of the sludge is transferred back to the inlet at the entrance of the lagoon and is mixed with the incoming effluent, creating an initial high sludge concentration. With this and other aerobic systems, provided that aeration is adequate, the higher the sludge concentration the faster the effluent can be treated. In one case it was reported that BOD removal was about 95% in the first lagoon and increased to 99% in the second. The comparable COD values were 94 and 98%.

Numerous more compact activated sludge systems, in which effluent flows through a series of aerated tanks and settling tanks, have been described. Several designs have been used in breweries. The Pasveer ditch consists of a shallow continuous ditch, roughly elliptical in plan, and with a trapezoidal cross-section, into which effluent flows and from which it flows to a settling tank. Some of the settled sludge is returned to the effluent inlet. The liquid is kept aerated and flowing around the ditch by brush beaters. The average retention time of effluent is often 2–3 days. When overloaded with effluent there are problems with sludge bulking, the plants occupy a large area and are in the open. Often breweries must use the least ground possible and the plant must not be obtrusive, particularly if situated in a town. Tall, thin, fully enclosed aerobic reactors may be chosen. An example is the deep-shaft reactor. These are typically 0.5–2.0 m (1.64–6.56 ft.) in diameter and extend 100–200 m (329–658 ft.) into the ground. In the centre of the shaft there is a downflow pipe and the annular space between the pipes acts as the riser. Initially the internal circulation is started by filling the shaft with effluent primed with activated sludge and then injecting air into the outer shaft. When the flow is established air is injected into the inner, down-shaft and as the bubbles are carried downwards it is efficiently dissolved as the pressure rises. As the pressure declines during the rise in the outer, annular shaft air and carbon dioxide break out of solution and the bubbles act as a gas-lift and maintain the circulation.

High removals of BOD from brewery effluents have been obtained (Lom and Fedderson, 1981; Vriens *et al.*, 1990). A comparable, above-ground tower system is

described later (Fig. 3.2). One type of a two-stage aerobic system is the Artois Unitank (Eyben *et al.*, 1985; Vriens *et al.*, 1986, 1990). In this system the effluent flows through a rectangular equalization tank, then through two rectangular aerobic/sludge settlement tanks working in series and so comprising a high-loaded tank and a low-loaded tank. Each aerobic/settlement tank is incompletely partitioned into three sections, so that liquid can move from one section into the next, but free mixing between the sections is prevented. The effluent flows from the equalization tank into the first compartment of the high-loaded treatment tank. It moves from compartment to compartment, meeting aeration and activated sludge in the first two. In the third compartment there is no aeration, the sludge settles and the treated effluent leaves, over a sludge-retaining weir, and flows to the low-loaded tank. At intervals of about two hours the flow in a tank is reversed and aeration now occurs in what was previously the settlement compartment (which is rich in settled sludge) and in the central compartment, but what was previously the inlet compartment is no longer aerated and becomes the settlement compartment. The third, low-loaded tank is operated in a similar way. BOD removal in the first tank is reported to be 80–88%, and to exceed 98% after the second tank treatment. At intervals surplus sludge is removed to a thickening tank. Promising trials with a novel, pilot-scale membrane reactor have been reported (Ward, 2000). The effluent from the enclosed, aerated and stirred chamber passed out by way of a membrane filter that retained all the suspended solids and microbes. Ferric sulphate, which acted as a coagulant, and nutrients were added to the aerated chamber and the pH was adjusted. Because the concentration of suspended microbes was exceptionally high and because no washout of activated sludge could occur, BOD removal exceeded 99%.

In some other aerobic treatment plants the biomass is attached to a supporting solid, and is in contact with the aerated effluent. The oldest of this type of system is the trickling bed filter, in which effluent is sprayed over the surface of a bed of rough solids (such as gravel, broken rocks, or coke) and trickles downward over the solid's surfaces, meeting an up-flow of air. The beds may be circular or rectangular in plan and 2–3 m (6.56–9.84 ft.) deep. The bed packing becomes coated with a very complex mixture of microbes and other organisms, which oxidize dissolved organic materials and reduce the BOD. As one pass is insufficient the liquid is recirculated. At intervals surplus sludge sloughs away and is collected in a settling tank. To cope with BOD-rich effluents several filters may operate in sequence. Such filters are expensive to build, they occupy a large area and they have a limited capacity, being liable to 'ponding' if overloaded. Sometimes problems arise from flies which multiply on the biomass. These filters have increasingly been replaced by high-rate biofiltration towers. These towers, which may be 4.3–6.1 m (14–20ft.) high, are packed with plastic units with shapes designed to support the biomass and to have a large surface to volume ratio but to be resistant to blockage. Effluent is sprayed into the top of the tower and as it trickles downward it meets an up-flow of air and is oxidized by the film of microbes on the plastic. Towers have capacities about ten times those of trickling filters covering the same areas. If desired the liquid can be re-circulated and a BOD removal of 60–65% is obtained, so they achieve a partial treatment. Towers are followed by settling tanks, which retain sludge. If followed by further treatment in a low-loaded activated sludge plant 97% BOD removal and 94% SS removal has been achieved. If towers are overloaded they, like trickling filters, can give rise to unpleasant odours.

Rotating disc contactors are another type of plant in which most of the biomass is supported on sets of lightweight plastic discs mounted side by side along a rotating axle. The surfaces of the slowly rotating discs are alternately immersed in a trough of effluent

and then, together with the film of liquid coating the surface, are exposed to air. Strips projecting from the faces of the discs form chambers, which cause air to be carried down below the surface of the liquid (Kühtreiber and Laa-Thaya, 1995). Discs are about 45% submerged. Much of the biomass is supported on the discs but some may float free in the liquid in the trough. Other forms of rotating contactors have also been used. The energy requirements of these devices are much lower than those using compressed air for aeration. BOD removal of 80–90% is possible.

Other types of aerobic treatment plants have been tried. For example, fluidised beds have been tested and some are in use (Section 3.2.4, Fig. 3.1). In these the biomass is supported in a granular, porous and relatively dense material. The mass, lifted into the flowing effluent by the aeration bubbles, achieves a high biomass density because the material supporting the biomass is too dense to be swept out of the aeration chamber, removing the need for a settlement tank. In another approach, in a pilot plant, the biomass was supported in small pieces of plastic sponge (Leeder, 1986). When these were overloaded with biomass the surplus was removed by collecting the pieces of sponge and squeezing them between rollers.

3.8.3 Sludge treatments and disposal

Aerobic effluent treatments inevitably produce considerable amounts of surplus biomass, 'sludge', which retains about 70% of the mass of the substances that contribute to the BOD. The treatment and disposal of this sludge is inconvenient and contributes substantially, about 50%, to the cost of the treatment (Armitt, 1981; Huige, 1994; Vriens *et al.*, 1986, 1990). Sludges differ in their characteristics, such as the ease with which they will settle and how compact they are. Normally sludges are collected by sedimentation when, with the addition of coagulants, they may have a solids content of 1–2% dry matter. After a further period of settling the solids content will increase to, say, 2–4%. After each concentration treatment the liquid that has separated is returned to the effluent treatment plant. The sludge may be consolidated further by centrifugation, vacuum filtration or in a pressure filter. Each consolidation reduces the volume of sludge to be handled and so reduces the transport costs as the material is carted away for disposal (Table 3.5). An alternative is to treat the sludge with coagulants followed by flotation and collection by skimming. In some circumstances the sludge may be 'stabilized', for example by aeration or by anaerobic digestion. Both of these treatments reduce the bulk. Anaerobic digestion is accompanied by the generation of methane-rich biogas, which can be used as a fuel. It is doubtful if this technique is used by brewers. It is used at some large sewage works. In some places dried sludge is incinerated, but again this does not seem to be suitable for brewers unless they are in a hot and dry region where the material can be dried spread on earth beds to dry in the open. Brewers usually have the sludge

Table 3.5 The influence of dewatering on the volume of sludge (Lloyd, 1981)

Stage of dewatering	Moisture content (%)	Equivalent volume
From settling tanks	98.5	100
After further settling	97.0	50
After decantation	95.5	33
After centrifugation	80.0	7
From vacuum filter	70.0	5
From filter press	65.0	4

removed by contractors who will bury it in landfill sites or may arrange to have it spread on farmland. The latter method of disposal is only available at certain times of the year. Because of its composition the sludge is potentially valuable. Markets for it have been sought, and it has been used (with or without admixture with lime) as a soil conditioner and has been used as a supplement in animal feeds.

3.8.4 Anaerobic and mixed treatments of brewery effluents

It was once considered impracticable to treat brewery effluents by anaerobic digestion, but methods for doing this have been developed (Anderson and Saw, 1986; Benson *et al.*, 1997; Driessen *et al.*, 1997; Eder, 1982; Fuchs, 1995; Gerards and Vriens, 1996; Hellriegel, 1996; Huige, 1994; Klijnhout and Van Eerde, 1986; Langereis and Smith, 1998; Love, 1987; Martin and Sanchez, 1987; Mayer and Eeckhaut, 1997; Pipyn *et al.*, 1983; Schumann, 1999; Schur *et al.*, 1995; Swinkels *et al.*, 1985; Vriens *et al.*, 1986, 1990). The effluent supplied to an anaerobic digestion plant must be carefully regulated in terms of its pH, flow, temperature, and BOD. These plants operate best on a steady flow of BOD-rich effluents and they are easily put out of commission by 'shocks' or traces of toxic substances, so preliminary mixing and buffering treatments must have been applied to the effluent input. Start-up times are slow (4–10 weeks) because the anaerobic micro-organisms multiply slowly. Despite these stringent requirements anaerobic plants are being used both because they produce very little sludge, and because they are comparatively compact (about 70% less space than aerobic plant) and cheap to construct and run (no aeration plant is needed) and because biogas is generated (0.3–0.5 m³/kg COD removed) and this may be used as fuel in the boiler house. Anaerobic systems never completely remove BOD (50–95%, usually 70–85%), and COD removal is generally 60–75%. Essentially no nitrogen or phosphate is removed by anaerobic treatments. They are best regarded as preliminary treatments for strong effluents that must be followed by an aerobic treatment for weak effluents, separated from the strong effluents at the brewery, and the effluent from the anaerobic treatment. This may occur either at the brewery or at the sewage works.

Anaerobic treatments occur in three stages, but often the first two take place in a single vessel. In the first stage, which may be aerobic, microbes generate and release hydrolytic enzymes that degrade the complex molecules present in the effluent to smaller molecules, e.g., polysaccharides to simple sugars, proteins to amino acids and free fatty acids are liberated from lipids. These simple molecules are easily assimilated by microbes. In the second, or 'acidification' stage, which is strictly anaerobic, many of these molecules are converted to organic acids. At this stage some biogas, containing hydrogen and carbon dioxide, is produced. The products of the acidification stage are good substrates for the microbes needed in the next stage, but the best cultural conditions are different. After the acidification process the pH (6.6–7.6), temperature, and nitrogen and phosphate levels are adjusted as the liquid flows to the 'methanization' vessel. Methanization is a strictly anaerobic process. It may be carried out at ambient temperatures (18–20 °C; 64.4–68 °F) or with thermophilic organisms at about 50 °C (122 °F) but in practice mesophilic conditions are usually chosen (about 35 °C, 95 °F). The effluent to be treated may be warmed by steam, partly produced by burning the biogas, and partly by heat recovered from the brewery. The biogas produced contains 55–75% methane, 1–5% hydrogen, 25–40% carbon dioxide and 1–7% nitrogen, as well as traces of ammonia and hydrogen sulphide. This gas needs to be scrubbed with sodium hydroxide to remove the carbon dioxide and this may need to be supplemented

with hydrogen peroxide to oxidize the hydrogen sulphide. Alternatively, the sulphide may be removed as iron sulphide or be adsorbed by silica gel. Escaping gases may be deodorized by passage through a biofilter.

Various kinds of equipment are in use for the anaerobic digestion of brewery effluents. Stirred vessels have been used, with or without the microbes being supported on solid carrier materials. The preferred systems now use the UASB or upward-flow anaerobic sludge blanket system in which acidified effluent is continuously mixed into the base of a reaction vessel. As the liquid rises it passes through a layer of agglomerated microbes which have formed spheres 2–5 mm in diameter. The process automatically selects for microbes which will clump together. The organic materials in solution are attacked by the microbes, which release biogas. Very little extra sludge is formed. The biogas rises, carrying some of the granular microbial blanket. Towards the top of the vessel the rising mixture meets a three-phase separator. The gas is collected and taken from the vessel and the granular microbial material, which had been carried up by the gas bubbles, settles back into the body of the reactor. The liquid flows up and over one or more weirs and leaves the vessel. After passing through a de-foamer and being scrubbed the biogas, now chiefly methane, may be stored in a gas-holder, be flared off or be directed to a boiler. In one case biogas provided 8% of the boiler's fuel requirements. The reactor requires a constant flow of liquor so if there is a check in the inflow of effluent the liquor is recirculated. It is advantageous to have two reactors working in series.

An example of an anaerobic and aerobic plant for partial effluent treatment is shown in Fig. 3.2. This plant, which was designed to occupy a small ground area, has a number of novel features (Driessen *et al.*, 1997; Meijer, 1998). The IC[®] reactor is a two-stage methanization tower, which can be regarded as having two UASB reactors mounted one above the other. In the aerobic, Circox[®] tower the microbes are supported on grains of

Fig. 3.2 (opposite) Diagram of an anaerobic/aerobic effluent treatment plant (after Driessen *et al.*, 1997). The fully enclosed plant is situated on a confined site (200 m²) in a built-up area. Screened waste water (design flow of up to 4,200 m³/day) is directed to a buffer tank (500 m³; 25 m high) or, in the case of alkaline or other 'extreme' wastes, to a calamity tank (150 m³), from where it may be metered into the buffer tank or to the sewer. Mixed effluent is transferred to the pre-acidification (PA) tank (500 m³; 25 m high) where acidification and the hydrolysis of polymeric materials occur and where the pH and nutrient levels are adjusted. Phosphoric acid and urea may be added if required. The acidified effluent goes to the base of the IC[®] reactor tower (390 m³; 20 m high). This is, in effect, two strictly anaerobic UASB reactors mounted one above the other. The influent enters the base (6) of the high-loaded reactor (1) and is mixed in with the surrounding fluid and granular microbial sludge. It rises through the sludge blanket in the reactor and meets the first three-phase separator (3). The gas rises to a de-foaming unit generating a gas-lift, and the liquid and entrained sludge return to (6) via a 'downer' pipe, (5). The sludge, from the first three-phase separator, settles back into the body of the reactor while the liquid rises into the second, low-loaded reactor (2), moves through the second sludge blanket and meets the second three-phase separator (4). The biogas is scrubbed, collected and utilized, the sludge is retained in the reactor and the effluent moves on to the Circox[®] reactor (230 m³; 19 m high). This second reactor is an aerobic tower, with an internal circulation through the inner, 'riser' pipe (7) and the outer, annular 'downer' channel. The circulation is maintained by the air-lift generated by the aeration air injected into the base. The ventilation air is drawn from all parts of the plant and sulphides in the air are oxidized to sulphate. The biomass is supported on granular basalt, so it readily sediments when it reaches the settling space (10). The gases rise through a pipe (9), and are vented. The effluent rises over weirs, which retain the biomass, and is directed by way of a cyclone tank that retains some suspended solids, but not fine suspended matter, like kieselguhr, which passes with the liquid into the sewer. The system is compact and has a rapid throughput with a low production of surplus sludge. The average reductions of the total COD and the soluble COD are 80% and 94% respectively.

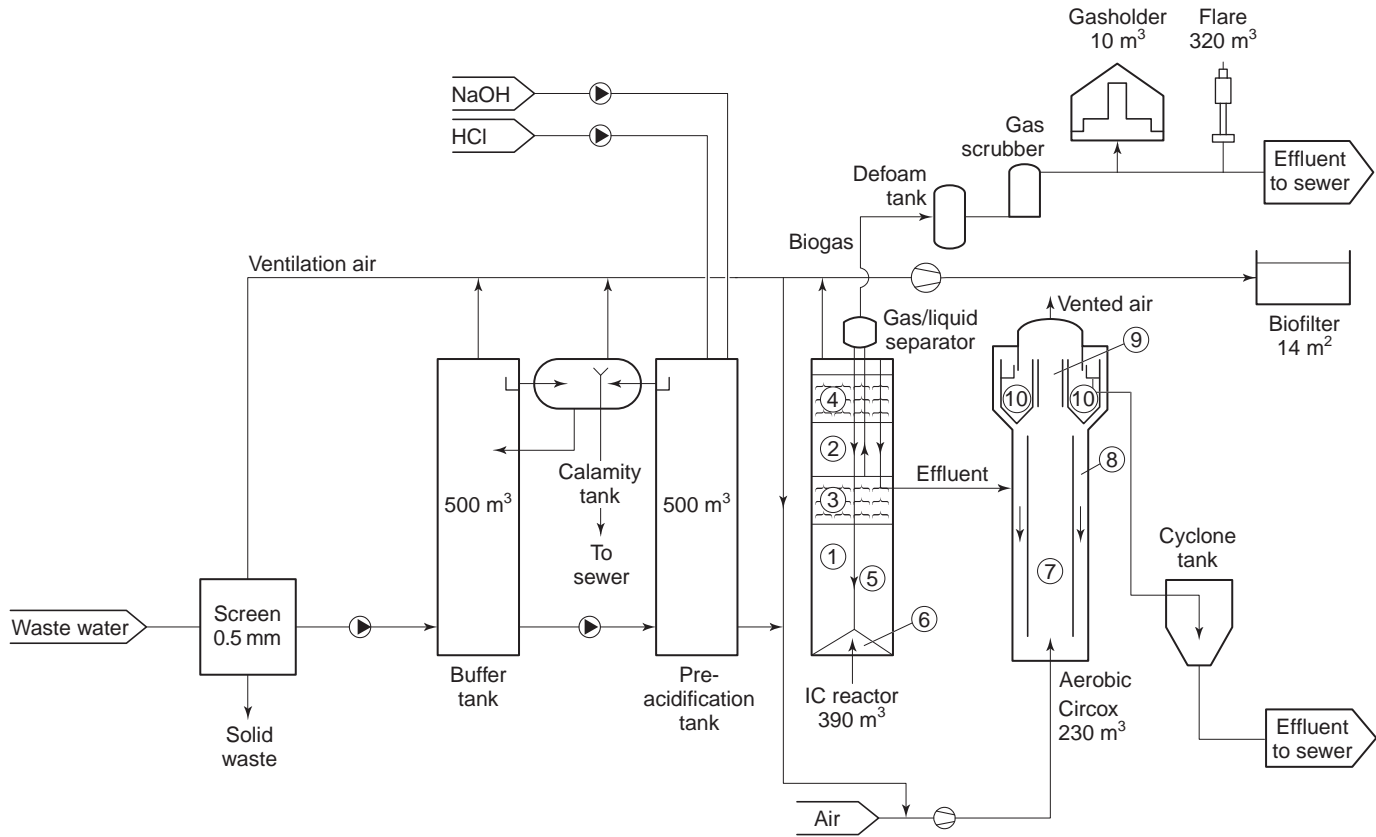

basalt, which readily settle and so preventing the biomass being washed out of the column. The plant removes 80% of the total COD and 94% of the soluble COD. In this particular plant the kieselguhr is not removed and is discharged in the final effluent, which is delivered to the sewer. Other combined anaerobic and aerobic plants have been described (e.g. Eyben *et al.*, 1985, 1995; Gerards and Vriens, 1996; Kühbeck, 1995; Mayer and Eeckhaut, 1997; Vriens *et al.*, 1990). Under aerobic conditions microbes take up phosphate, and many store it as polyphosphate, and so this is removed from the effluent. The situation with nitrogen removal is more complex (Vriens *et al.*, 1990). Aerobic conditions are needed to oxidize ammonium ions to nitrate, then anaerobic conditions are required for the nitrate to be reduced to nitrogen gas which is removed from the system (Eyben *et al.*, 1995).

3.9 Other water treatments

Reedbeds have been used to treat some crude or partially purified malting effluents or even some sludge (Maule *et al.*, 1996; Walton, 1995). They are essentially shallow tanks filled with a permeable support such as limestone chips on which reeds, e.g., *Phragmites spp.* and perhaps yellow flag iris are planted. The effluent percolates through the beds, among the roots of the plants. Suspended solids have been reduced from 80 to less than 20 mg/l, and COD from 60 to less than 10 mg/l. The removal of nitrogen and phosphate appears to be satisfactory. A problem with reed beds is that they occupy large areas of ground.

Treated effluents have been polished in various ways, including passage through reed beds, passage through large, shallow lagoons (with or without forced aeration), and recycling through percolating filters. As the cost of acquiring water continues to rise and the pressure to treat effluents to higher standards continues to increase it is inevitable that brewers working in large breweries will frequently consider purifying their effluents sufficiently to allow the water to be recovered and used, at least for some purposes, so minimizing water acquisition and effluent disposal charges. The re-use of effluent is likely to involve a two-stage aerobic or an anaerobic/aerobic treatment, followed by a polishing treatment, sterilization, sand filtration possibly followed by finer filtration, carbon filtration and perhaps ultrafiltration or demineralization by ion exchange.

3.10 References

- ANDERSON, G. K. and SAW, C. B. (1986) *Pauls Brewing Room Book, 1986–1988* (8th edn), Pauls' Malt, Ipswich, p. 37.
- ANDERSSON, L. E. and NORMAN, H. (1997). *Brew. Distill. Internat.*, **28** (7), 18.
- ANON. (1988) *European Brewery Convention Monograph XIV. EBC Symposium. Water in the Brewing Industry*, Zoeterwoude.
- ARMITT, J. D. G. (1981) in *Brewing Science 2* (Pollock, J. R. A., ed.) Academic Press, London, p. 551.
- ASKEW, M. (1975) *Process Biochem.*, **10** (1), 5.
- ASKEW, M. (1987), *Brewer*, **73**, Nov., p. 500.
- ASKEW, M. and ROGERS, S. (1997), *Brewers' Guard.*, **126** (5), 24.
- BAK, S. N., EKENGREN, Ö., EKSTAM, K., HÄRNULV, G., PAJUNEN, E., PRUCHA, P. and RASI, J. (2001) *European Brewery Convention Manual of Good Practice. Water in Brewing*. Hans Carl, Nürnberg, 128 pp.
- BAXTER, E. D. and HUGHES, P.S. (2001) *Beer: quality, safety and nutritional aspects*. Cambridge. The Royal Society of Chemistry, 138 pp.
- BENSON, J. T., COLEMAN, A. R., DUE, J. E. B., HENHAM, A. W., TWAALFHOVEN, J. G. P. and VINCKX, W. (1997) *European Brewery Convention Manual of Good Practice: Brewery Utilities*. Hans Carl, Nürnberg, p. 137.

- BERKMORTEL, H. A. VAN DEN. (1988a) *European Brewery Convention Monograph XIV. EBC Symposium. Water in the Brewing Industry, Zoeterwoude*, p. 49.
- BERKMORTEL, H. A. VAN DEN. (1988b) *MBAA Tech Quart.*, **25**(3), 85.
- BLACKMANN, B. (1998) *Brewers' Guard*, **127**, Apr., p. 30.
- BRAUN, G. and NIEFIND, H.-J. (1988) *European Brewery Convention Monograph XIV. EBC Symposium. Water in the Brewing Industry, Zoeterwoude*, p. 68.
- BRIGGS, D. E., HOUGH, J. S., STEVENS, R. and YOUNG, T. W. (1981) *Malting and Brewing Science, Vol I, Malt and Sweet Wort* (2nd edn). Chapman and Hall, London. p. 194.
- BROOKS, R. B., HALFORD, M. H. and SKINNER, R. N. (1972) *Proc. 12th Conv., Inst. of Brewing (Australia and New Zealand Sect.)*, Perth, p. 73.
- BROWN, J. W., BOTT, N.J., BOWERMAN, R. and SMITH, D. (1999) *Proc. 27th Congr. Eur. Brew. Conv., Cannes*, p. 225.
- BYRNE, H. (1990) *Ferment*, **3**(2), 90.
- CLEATHER, T. G. (1992) *Proc. 5th Internat. Brew. Tech. Conf., Harrogate*, p. 287.
- COMRIE, A. A. D. (1967) *J. Inst. Brewing*, **73**, 335.
- COORS, J. H. and JANGAARD, N. O. (1975) *Proc. 16th Congr. Eur. Brew. Conv., Nice*, p. 311.
- COWAN, J. A. and WESTHUYSEN, J. VAN DER (1999) *Proc. 7th Sci. Tech. Conv. Inst. Brewing, Africa Sect., Nairobi*, p. 193.
- CRISPIN, P. (1996) *Brewers' Guard.*, **125**(9), 34.
- DRIESSEN, W., HABETS, L. and VEREIJKEN, T. (1997) *Ferment*, **10**(4), 243.
- EDEN, G. E. (1987) *Brewer*, **73**, Nov., 504.
- EDER, L. J. (1982) *MBAA Tech Quart.* **19**(3), 111, 138.
- EUMANN, M. (1999) *Proc. 7th Sci. Tech. Conv. Inst. Brewing, Africa Sect., Nairobi*, p. 169.
- EYBEN, D., GERARDS, R. and VRIENS, L. (1995) *MBAA Tech. Quart.*, **32**(3), 142.
- EYBEN, D., VRIENS, L., FRANCO, P. and VERACHTERT, H. (1985) *Proc. 20th Congr. Eur. Brew. Conv., Helsinki*, p. 555.
- FUCHS, C. B. (1995) *MBAA Tech. Quart.*, **32**, 85.
- GERARDS, R. and VRIENS, L. (1996) *Proc. 24th Conv. Inst. Brewing, Asia-Pacific Section, Singapore*, p. 192.
- GOUGH, A. J. E. (1995) *MBAA Tech. Quart.*, **32**, 195.
- GRANT, A. P. (1995) *Ferment*, **8**(4), 252.
- HACKSTAFF, B. W. (1978) *MBAA Tech. Quart.*, **15**(1), 1.
- HARRISON, J. G., LAUFER, S., STEWART, E. D., SIEBENBERG, J. and BRENNAN, M. W. (1963) *J. Inst. Brewing*, **69**(4), 323.
- HARTEMANN, P. (1988) *European Brewery Monograph XIV. EBC Symposium, Water in the Brewing Industry, Zoetewoude*. p.37.
- HELLRIEGEL, K. (1996) *Brauwelt Internat.*, **14**(5), 422.
- HERON, J. R. (1989) *Ferment*, **2**(2), 118.
- HORRIGAN, R., LLOYD, W. J. W. and YOUNG, I. M. (1989) *Project No. 59. Report of the Joint Maker/User Committee, Inst. Brewing and ABTA. Conservation of water and reduction of effluent*.
- HUGHES, D. A. (1987) *Brewer*, **73**(872), 266.
- HUIGE, N. J. (1994) in *Handbook of Brewing* (Hardwick, W. A., ed.), Marcel Dekker, New York. p.501.
- IBBOTSON, G. E. (1986) *Brewer*, **72**(859), 169.
- ISAAC, P. G. (1976) *Process Biochem.* **11**(2), 17.
- ISAAC, P. C. G. and ANDERSON, G. K. (1973), *J. Inst. Brewing*, **79**, 154.
- KLIJNHOUT, A. F. and VAN EERDE, P. (1986) *J. Inst. Brewing*, **92**, 426.
- KÜHBECK, G. (1995) *Proc. 25th Congr. Eur. Brew. Conv., Brussels*, p. 751.
- KÜHREIBER, F. and LAA-THAYA, A. (1995) *Brauwelt Internat.* (1), 45.
- KUNZE, W. (1996) *Technology Brewing and Malting*, VLB, Berlin, p. 60.
- LANGEREIS, W. H. and SMITH, C. G. (1998) *Proc. 25th Conv. Inst Brewing, Asia-Pacific Sect., Perth*, p. 187.
- LEEDER, G. I. (1986) *Brewer*, **72**, p. 213.
- LLOYD, W. J. W. (1981) *Brewer*, **67**, 396.
- LOM, T. and FEDDERSON, C. C. (1981) *Proc. 18th Congr. Eur. Brew. Conv., Copenhagen*, p. 121.
- LOVE, L. S. (1987) *MBAA Tech. Quart.*, **24**(2), 51.
- LUNNEY, M. J. (1981) *Brewers' Guard*, **110**(1), 13.
- MAILER, A., PEEL, R. G., THEAKER, P. D. and RAVINDRAN, R. (1989) *MBAA Tech. Quart.*, **26**, 35.
- MARTIN, S. and SANCHEZ, R. (1987) *Proc. 21st Congr. Eur. Brew. Conv., Madrid*, p. 655.
- MAULE, A. P., TRUMPESS, C. R. and THURGOOD, S. D. (1996) *Proc. 6th Internat. Brew. Tech. Conf., Harrogate. Brewing Technology, the Market and the Environment*. p. 408.
- MAYER, W. and EECKHAUT, M. (1997) *Brauwelt Internat.*, **15**(5), 414.
- MCGARRITY, M. J. (1990) *Louvain Brewing Lett.*, **4**(3/4), 3.
- MEIJER, D. (1998) *Brauwelt Internat.*, **16**, 455.
- MEYER, H. (1973) *Proc. 14th Congr. Eur. Brew. Conv., Salzburg*, p. 429.
- MOLL, M. (1979) in *Brewing Science*, **1** (Pollock, J. R. A., ed.) London, Academic Press. p. 539.

- MOLL, M. (1995) in *A Handbook of Brewing* (Hardwick, W. A. ed.). New York, Marcel Dekker, p. 133.
- PENROSE, J. D. F. (1985) *Brewers' Guard.*, **114**, 25.
- PIPYN, P., OMBREGT, J. P. and TOYE, J. (1983) *Proc. 19th Congr. Eur. Brew. Conv., London*, p. 587.
- PUTMAN, R. (2001) *Brewer Internat.*, **2**(4), 27.
- REED, R. and HENDERSON, G. (1999/2000) *Ferment* **12**(6), 13.
- ROBERTSON, J. L., BROWN, L. C. and MURPHY, K. L. (1979) *MBAA Tech. Quart.* **16**(1), 33.
- ROSTRON, J. (1996) *Brewers' Guard.*, **125**, (5), 20.
- RUDIN, A. D. (1976) *Brewers' Guard.*, **105**(12), 30.
- SCHUMANN, G. (1999) *Brauwelt Internat.*, **17**(5), 374.
- SCHUR, F., BHEND, D., BUCHER, A. J. and WETZEL, E. (1995) *Proc. 25th Congr. Eur. Brew. Conv., Brussels*, p. 741.
- SWINKELS, K. T. M., VEREIJKEN, T. L. F. and HACK, P. J. F. (1985) *Proc. 20th Congr. Eur. Brew. Conv., Helsinki*, p. 563.
- TAYLOR, D. (1981) *Brew. Distill. Internat.*, **11**, 35, 42.
- TAYLOR, D. G. (1989) *Ferment*, **2**(1), 76.
- THEAKER, P. D. (1988) *Brewers' Guard.*, **117**(3), 22.
- THOMPSON, J. (1995) *Ferment*, **8**(3), 177.
- VEREIJKEN, T. L. F., DRIESSEN, W. J. B. and YSPEART, Y. (1999) *Proc. 7th Sci. Tech. Conf. Inst. Brewing, Africa Sect., Nairobi*, p. 174.
- VRIENS, L., EYBEN, D. and VERACHTERT, H. (1986) *Proc. Symp. J. De Clerck Chair II; Microbiology and the Brewing Industry from Barley to Beer*. Leuven/Louvain, p. 128.
- VRIENS, L., VAN SOEST, H. and VERACHTERT, H. (1990) *CRC Crit. Revs. Biotechnol.*, **10**(1), 1.
- WALKER, M. J. (1994) *Proc. 4th Aviemore Conf. On Malting, Brewing and Distilling*. London, Inst of Brewing, p. 345.
- WALTON, C. (1995) *Brew. Distill. Internat.*, **26**(7), 29.
- WARD, J. A. (2000) *Proc. 26th Conv. Inst. Brewing, Asia-Pacific Sect., Singapore*, p. 122.

4

The science of mashing

4.1 Introduction

Mashing consists of mixing ground malt (usually a mixture of malts) and other prepared grist materials (appropriate adjuncts and sometimes salts and sometimes supplementary enzymes, Chapter 2) with a carefully controlled amount of liquor at a chosen temperature. In some few instances the mash may be made with mainly, or entirely, unmalted preparations of cereals mixed with industrial enzymes. The liquor is nearly always pre-purified and contains a chosen mixture of dissolved salts (Chapter 3). In the simplest systems, after a 'stand' or stands of various durations, at one or more selected temperatures, the liquid, or 'sweet wort' is separated from the residual solids of the mash, the spent grains or draff. In other cases portions of the mash are withdrawn and heated before being added back to the 'main mash' while in other cases cereal preparations, cooked in a separate vessel, are transferred and mixed into the main malt mash. Representative mashing schedules are considered below. The sweet wort goes forward to the kettle or copper, to be boiled with hops, while the spent grains are disposed of (Chapter 3). The, apparently simple, processes of mashing conceal a very complex mixture of physical, chemical and biochemical changes. An understanding of these changes has been essential to permit the logical development of mashing conditions for the preparation of desirable and uniform worts in rapid and reproducible ways. Thus the purpose of mashing is economically to prepare wort of the correct composition, flavour and colour in the highest practical yield and in the shortest time.

The wort is partly characterized by its 'strength', the amount of solids, or 'extract' that are in solution and the volume of liquid in which the solids are dispersed. Unfortunately, the concentration of wort is expressed in a variety of different units (Appendix). In the simplest case the specific gravity is used as a measure. The higher the specific gravity the more concentrated the solution of wort solids. For example, a wort might have a specific gravity (s.g.) of 1.040 at 20 °C (68 °F), relative to pure water at 1.000, or the same wort has an SG of 1040 relative to water as 1000.0. In other systems the amounts of solids in solution are estimated from the s.g. and reference to tables relating to the s.g. values of sucrose solutions, either from the table of Balling (ASBC) or the table of Plato (EBC; see

Appendix). So a wort with an SG of 1040 has a concentration of solids of about 9.99% (w/w) assuming that the wort solids influence the SG in an identical way to sucrose. In the old British system (pre-1977) the extract in a barrel of wort at 15.5°C (60°F) was the excess weight of a barrel of wort in pounds (lb.) over the weight of a barrel of water, 360 lb. So the $SG = (\text{excess Brewer's lb.} + 360)/360$. So in the case given, $SG = 1040$ (at 15.5°C), the excess $SG = 40$ so the extract, in Brewer's lb. = $40 \times 0.36 = 14.4$. The efficiency of mashing is often estimated by comparing the extract recovered in the brewery with that obtained in laboratory mashes when the hot water extract (HWE) of the grist is determined. Reliable estimates of extract recoveries are not freely available, but while in old mash tuns the value might be about 85–95%, in newer mash filters the value may equal or just exceed 100%, a commercially valuable advantage provided that wort quality is maintained.

The importance of enzymes in mashing is illustrated by the fact that a cold water extract of a pale malt (CWE; preformed soluble materials), prepared in a cool, dilute solution of ammonia to stop enzyme activity, will be in the range 15–22%, dry basis, while the hot water extract (HWE) will be 75–83%, dry basis. Thus, by holding a small-scale mash for between one and two hours under conditions such that enzyme activity is favoured, some 53–68% more of the malt solids are brought into solution as the result of enzyme-catalysed reactions. While about half of the CWE solids are fermentable by yeasts typically 75% and up to about 85% of the HWE is fermentable. The enzyme catalysed changes that occur during mashing are more complex than those normally investigated by biochemists, who usually study each enzyme acting in isolation, with a homogeneous substrate, at one temperature, with an unchanging pH and with a large excess of substrate to maintain enzyme activity.

In contrast, in mashing, a very large number of enzymes act simultaneously on the components of the grist (malt and mash tun adjuncts) under conditions that are far from optimal for many of them in terms of substrate concentration and accessibility, pH and enzyme stability. Enzymes are inactivated at different rates depending on the temperature, the pH, the presence of substrate and other substances (such as tannins and cofactors such as calcium ions) in solution. Starch, proteins, nucleic acids, lipids and other substances are attacked, usually by hydrolytic reactions, but other reactions, such as oxidations, also occur. Not only are enzymes progressively inactivated but substrate concentrations alter and, in the case of starch for instance, are nearly totally degraded. Solid starch granules are not readily degraded until gelatinization temperatures are approached and starch grains are disrupted. The polysaccharide cell walls and the starch granules are coated with proteins that seem to impede their enzymic degradation. Where grist particles are relatively large and the cell walls are intact, as in unmodified fragments of malt and some adjuncts, the cell walls prevent enzymes reaching and degrading the cell's contents. In many instances the products of hydrolysis competitively inhibit enzyme activity and in a number of instances (e.g. α -amylase, limit dextrinase and some proteolytic enzymes) proteins occur which partially or largely inhibit enzyme activities. In addition some enzymes occur bound to insoluble materials in the mash, preventing them diffusing and so limiting their ability to reach their substrates. This is true of β -amylase, proteases and α -glucosidase in malts. The significance of insoluble enzymes and the presence of endogenous enzyme inhibitors in mashes has been widely ignored.

A knowledge of the properties of enzymes is essential for an understanding of mashing regimes, yet the traditional methods for studying their properties are of limited use. Brewers make use of the concept of 'optima' in considering enzyme activities in mashes. This is helpful, but it must be realized that a temperature or a pH optimum is not a true

constant. Under any particular set of conditions an enzyme may be stable and so, when it is incubated with a substrate, product(s) will be formed at a constant rate until substrate concentration is reduced to a significant extent. If the temperature is increased then the reaction catalysed will proceed faster. However, if at this higher temperature the enzyme is progressively inactivated then the rate of formation of the product(s) will decline and will ultimately stop even if some substrate remains. At progressively higher temperatures the reaction rates catalysed by the 'native', undenatured enzyme will increase, but the rate of enzyme inactivation also increases and so the production of product will cease sooner. Thus the amount of product formed, at a particular temperature in a given time, will depend on the rates of catalysis and on the rate of enzyme inactivation. The longer the reaction period the lower the optimum temperature, that is, the temperature at which the most product will have been produced (Fig. 4.1). In mashing, the rate of appearance of a substance depends on the mixture in the grist, the mash thickness, the fineness of the grind and so the particle size distribution in the grist. Similarly the optimum pH of a reaction varies with the test conditions. The situation with pH is complicated by the frequent failure to take account of the pH changes that occur as the temperature is altered, and the difficulty of measuring pH at the elevated temperatures used in mashing (see below).

Sweet wort is viscous, sweet, dense, sticky and more or less coloured. Its composition is highly complex (probably thousands of components are present). No wort has ever been completely analysed. Substances present include simple sugars, dextrans, β -glucans, pentosans, phosphates, dissolved inorganic ions, proteins, peptides and amino acids, nucleic acid breakdown products, lipids, yeast growth factors (vitamins), organic acids, bases and phenolic substances. Sometimes it is desirable to analyse a chemical fraction in detail, but this is not always the case. A 'typical' sweet wort may contain solids consisting of about 90–92% carbohydrates, 4–5% nitrogen-containing substances and

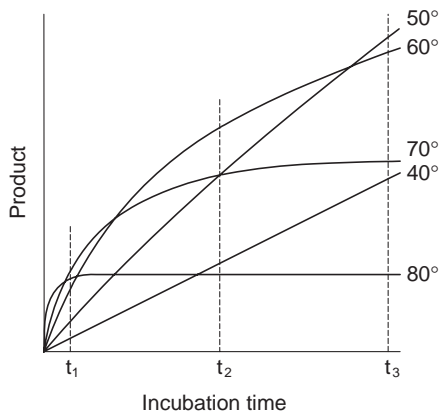

Fig. 4.1 Graphs illustrating the appearance of products in idealized enzyme-catalysed reactions carried out with the initial conditions the same but at different incubation temperatures ($^{\circ}\text{C}$) (after Dixon and Webb, 1958). As the temperature is increased so the initial reaction rate, at time zero, increases. In the sample, at 40°C the enzyme is stable and so the reaction carries on at a steady rate (substrate is present in excess), and product is formed linearly with time. However, at higher temperatures the enzyme is less stable and so, although the initial reaction rates are more rapid, enzyme is progressively inactivated and the rates of product formation decline. If the maximum amounts of product formed at different times are noted it can be seen that at the shortest time, t_1 , the 'optimum' is at 70°C , at t_2 it is at 60°C while at the longest time, t_3 , it is at 50°C .

1.5–2% ash (MacWilliam, 1968). As yeast ferments wort the simpler sugars are partly converted into ethyl alcohol and carbon dioxide, and the specific gravity of the mixture progressively declines until fermentation is complete. This final value is the attenuation limit of the wort and mainly depends on the carbohydrate spectrum of the wort (Chapters 12 and 14). During the hop-boil the fermentability of the wort and its strength may be adjusted by the addition of carbohydrate adjuncts (Chapter 2). Enzymes remain in sweet wort, slowly increasing its fermentability, which is not fixed until the wort is boiled. Fermentability values are calculated from the changes in specific gravity.

Wort colour must be within specification, and so must the nitrogen (crude protein = $N \times 6.25$) fractions of the wort. Total soluble nitrogen (TSN) is self-explanatory. Free amino nitrogen (FAN) is a measure of the low molecular weight substances, mainly amino acids, which are needed to support yeast growth and metabolism. Older measures included coagulable-N (nitrogen containing material that was precipitated when the wort was boiled) and permanently soluble nitrogen, (PSN) which remained in solution. Formol-N was an older method of estimating the amino acid and peptide fraction.

4.2 Mashing schedules

Mashing schedules vary widely. One is chosen with reference to the beer type to be made, the way it has been made in the past, the plant and raw materials that are available and the energy consumption and speed of the process. There is a trend towards temperature-programmed infusion mashing but some brewers have not been able to 'match' their traditional products when changing from older types of mashing programmes, and so these have been retained. At present a range of brewing procedures are in use and they are carried out in many different types of equipment (Chapters 5 and 6). In many small breweries it is normal to mash not more than once a day, but in some large production units the target is to mash 12–14 times every 24 hours. This has necessitated many changes in equipment and mashing practices. It is convenient to distinguish between traditional infusion mashing, decoction mashing, double mashing, temperature-programmed infusion mashing and 'all-' or 'mainly-adjunct' mashing, although the distinctions between these classes are not absolute. Some 'mixed' mashing systems are used in Belgium (Briggs, *et al.*, 1981; De Clerck, 1957; Kunze, 1996; Narziss, 1992a; Hind, 1950; Wright, 1892). The mechanisms of grist preparation and mashing are discussed in Chapters 5 and 6.

Before 1945 the infusion mashing carried out in the UK typically involved making a thick mash with well modified and comparatively coarsely ground malt or malts, mixed with 5–15% of flaked maize or flaked rice adjunct. The grist was mixed with hot liquor (water) at a temperature ('liquor heat' or 'striking heat') chosen to give a particular 'initial heat' or mash temperature. After a stand of about 30 minutes, when the mash gave a negative iodine test for starch, an underlet (hot water added into the bottom of the mash) might be given to raise the temperature then, after a total period of 2–3 h, wort collection, recirculation and sparging would begin. Typically on mashing in the liquor/grist ratio would be 2.15–2.42 hl/100kg grist (2–2.25 imp. brl/Qt.) and the temperature would be 63.4–67.2 °C (146–153 °F). After underletting, with additions of hot water of 0–1.34 hl/100kg (0–1.25 imp. brl/Qt.) the temperature of the mash would be 66.6–68.8 °C (152–156 °F). Finally, the wort would be collected and the goods (residual solids) were sparged with 3.76–4.30 hl/100 kg (3.5–4 imp. brl/Qt.) of liquor at 75–77 °C (167–170.7 °F). Thus the whole process from mashing in to finishing collecting the

wort would take at least six hours. In one brewery the whole process took 18 hours. This process cannot be greatly accelerated.

The choice of good quality malt minimizes the chance of a set mash and allows the stand to be shortened to 1–1.5 h, and a shortening of the wort separation time and the addition of some hydrolytic enzymes can accelerate wort separation. Mashing directly in a lauter tun, rather than a mash tun, allows the use of a more finely ground grist and faster wort separation. By shortening the stand period and by accelerating sparging, time can be saved but at the risk of reducing extract recovery and altering the quality of the wort. The total volumes of liquor used were 6.98–7.52 hl/100 kg grist (6.5–7.0 imp. brl/Qt.). Modern infusion mashes are made with 1.6–3.2 hl liquor/100 kg grist (1.5–3.0 imp. brl/Qt.). Torrefied cereals or wheat flour are commonly used adjuncts. The initial temperature is usually in the range 63–67°C (145.5–152.7°F) and is best held for 1–3 h. The temperature of the mash rises during sparging. This type of mashing does not allow air to be excluded from a mash, and indeed the entrained air bubbles cause much of the mash to float. This is no disadvantage, and may even be desirable, for making traditional, cask-conditioned British beers. However, with other beers, intended to have very long shelf-lives, efforts are increasingly being made to exclude air from the mash and the hot wort. To achieve this equipment other than a mash tun must be used. In special cases, when alcohol production is to be minimized, the mashing-in temperature is increased to, e.g., 75°C (167°F) to allow α -amylase to liquefy and dextrinize the starch while minimizing saccharification by β -amylase and so producing a less fermentable mixture of carbohydrates.

In traditional continental European decoction mashing a thin mash (3.5–5 hl liquor/100 kg. grist; 3.26–4.66 imp. brl/Qt.) is made from undermodified malt that is comparatively finely ground. The thin mash is necessary to permit it to be stirred and pumped between mashing vessels. In this, and the other mashing systems to be considered, the mash conversion processes are carried out in vessels that are separate from the devices (lauter tuns or mash filters) in which the wort is separated from the residual spent grains. Because the mash is stirred and portions of it are pumped between vessels air is not entrained and the solids do not float. When portions of the mash are boiled the starch is gelatinized and becomes susceptible to enzymic attack, residual cellular structures are disrupted, proteins are denatured and precipitated, enzymes are inactivated, chemical processes are accelerated, flavour substances (not necessarily desirable) appear in the wort and the wort darkens. Unwanted substances such as pentosans and β -glucans are extracted. Boiling portions of the mash is expensive because it involves the consumption of energy. The successive temperatures, which occur in the ‘main, mixed mash’, allow key enzymes to act at or near their optimal temperatures. In decoction mashing the grist is mashed into the mash-mixing vessel, which has a stirrer and may have heat-exchanging surfaces to allow the temperature of the contents to be increased. At intervals aliquots of the mash are withdrawn to the decoction vessel where they are heated, rapidly or slowly as the programme requires, with or without ‘rests’ at particular temperatures, to boiling. After a period of boiling the hot material is pumped back into, and is mixed with, the main mash raising its temperature at a predetermined rate to a pre-chosen value. Before a decoction is carried out the stirrer in the mash-mixing vessel may be turned off and the mash allowed to settle. Then part of the settled ‘thick mash’ is pumped to the decoction vessel.

If adjuncts are permitted they may be cooked, with some of the malt mash and possibly added microbial enzymes, in the decoction vessel. The mash is allowed to stand until the next temperature rise, created either by another decoction, or by direct heating or

by sparging. At the end of the mash conversion period the mash is transferred either to a lauter tun or to a mash filter for wort separation. With undermodified malts double decoction mashing is said to recover 2% more extract than an infusion mash and a single decoction process recovers 1.5% more extract. These gains are made at the expense of higher energy costs, as boiling part of a mash requires heat. With well-made malts the advantages, if present, are very small if temperature-programmed infusion mashing is employed. The brewing problems created by using poorly modified malts are such that their use is now avoided where possible and so the need for decoction mashing is going. On the other hand some mainland European beers have their full and desirable range of characteristics only if their worts are prepared by decoction mashing.

In British infusion mashing, carried out with well modified malts, extract yield is likely to be limited by the extract recovery from the mash, rather than the extent of the mash conversion. In other words extract will remain in the spent grains. Decoction mashing schedules are very flexible and are easily adjusted (Kunze, 1996; Narziss, 1992a, b). In the classical three-decoction process (Fig. 4.2) light beers are made with a liquor/grist ratio of 4.8–5.4 hl/100 kg grist (4.5–5 imp. brl/Qt.) while dark beers are made with thicker mashes, 3–4 hl/100 kg (2.75–3.75 imp. brl/Qt.). In the decoctions used when making light beers, the boiling periods are shorter than when dark beers are being made. The grist may be mashed in with cold water and the temperature is raised to 35–40 °C (95–104 °F) either by adding hot water, or by direct heating, while the mash is stirred. The main mash may be allowed to remain at this temperature for about two hours. During this stand heat-labile enzymes, such as β -glucanase, maltase, proteases and phytase, have a chance to act. The pH of the mash may fall, partly due to the activities of lactic acid bacteria. After about one hour into this period a third of the mash (stirred ‘thin’ or settled and ‘thick’) is transferred to the decoction vessel and is heated to boiling, often

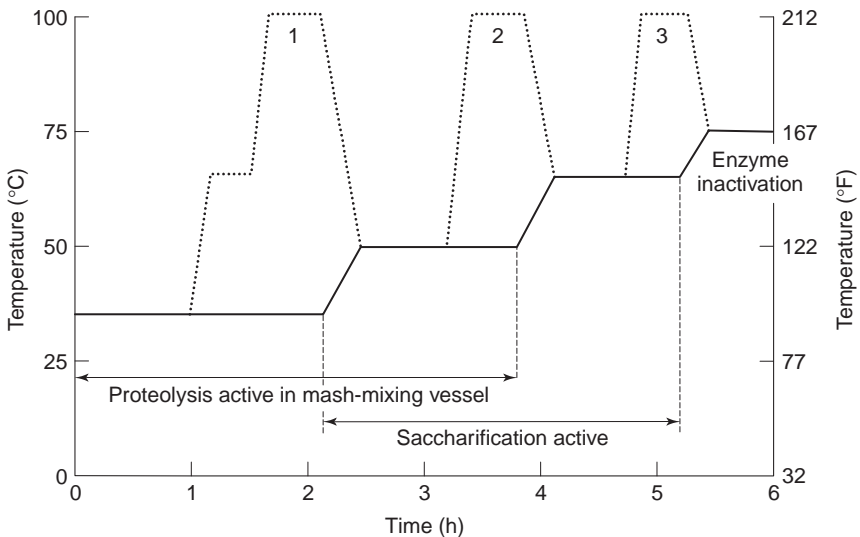

Fig. 4.2 The temperature changes occurring in a typical, traditional triple-decoction mashing programme (after Hind, 1950). —, temperatures in the main mash vessel. ····· temperatures in the mash copper during the first, second and third decoctions (1, 2 and 3). About one-third of the mash is used in each decoction. A ‘thick mash’ or a mixed mash may be used. The ‘proteolysis’ and other periods are the oversimplified, traditional names for the divisions of the process. Process duration, about six hours.

with a rest at 65–70 °C (149–158 °F) to allow α -amylase to liquefy the starch. After a period at 100 °C (212 °F), say 15 min. for pale beers and 45 min. for dark beers, the hot mixture is added back to the stirred main mash, increasing its temperature to 50–53 °C (122–127 °F). During the next rest the surviving enzymes begin to attack the gelatinized and liquefied starch and proteolysis continues relatively quickly. A second decoction, also with about a third of the mash, which may or may not have a ‘rest’ during heating at about 65 °C (149 °F) to liquefy starch, increases the temperature of the main mash to about 65–70 °C (149–158 °F). A final decoction increases the temperature to about 76 °C (169 °F) then, after a short rest, the mash is transferred to the lauter tun or filter and wort collection begins. A three-decoction mash may last six hours. As with other mashes the exact temperatures chosen, the duration of the rests and boils and the rates of mash heating and mixing can be varied. However, with well-modified malts such a process is unnecessary. It is too long, too complex and the three boils are too expensive.

Many faster and more economical double- and single-decoction procedures are used. For example, malt may be mashed in at 35 °C (95 °F) and, after a short rest, the temperature of the mash is raised to around 52 °C (126 °F; Fig. 4.3). Two successive decoctions, each with a quarter of the mash, increase the main mash temperature to 65–70 °C (149–158 °F) and then 76 °C (169 °F). The whole process takes about 4.5 h. Many more rapid double-decoction processes have been described and in each case better modified malts are needed and the processes more nearly approach the conditions used in infusion mashing. For example, a mash is prepared at 63 °C (145 °F) and after a short stand about a quarter of the mash, possibly a ‘thick mash’, is withdrawn and boiled (Fig. 4.4). When it is mixed into the main mash the temperature is increased to 70 °C (158 °F). After a rest of 45–60 min. a second decoction, also with about a quarter of the mash, is used to increase the main mash temperature to about 77 °C (171 °F). After about 30 min. wort collection can begin. The whole process takes 2–3 h.

Single decoction mashes are even simpler. For the preparation of dark beers the mash may be given a preliminary long stand at a low temperature. This can allow the

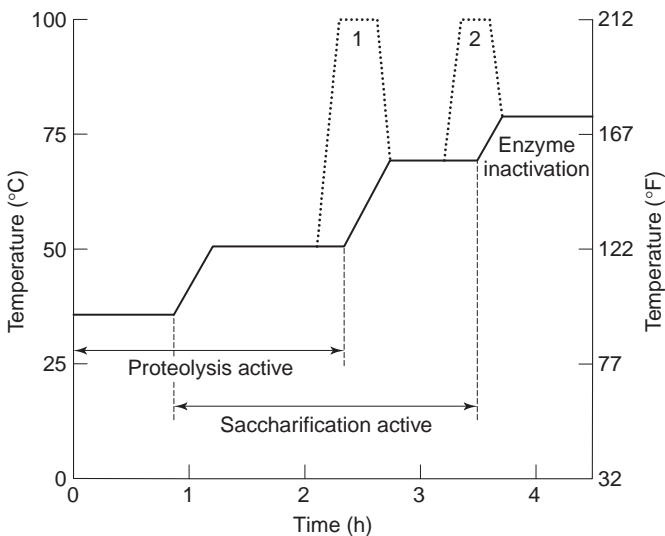

Fig. 4.3 A temperature scheme for a typical two-decoction mashing programme (after Hind, 1950). The key is in Fig. 4.2. About a quarter of the mash is used in each decoction. Process duration, four and a half hours.

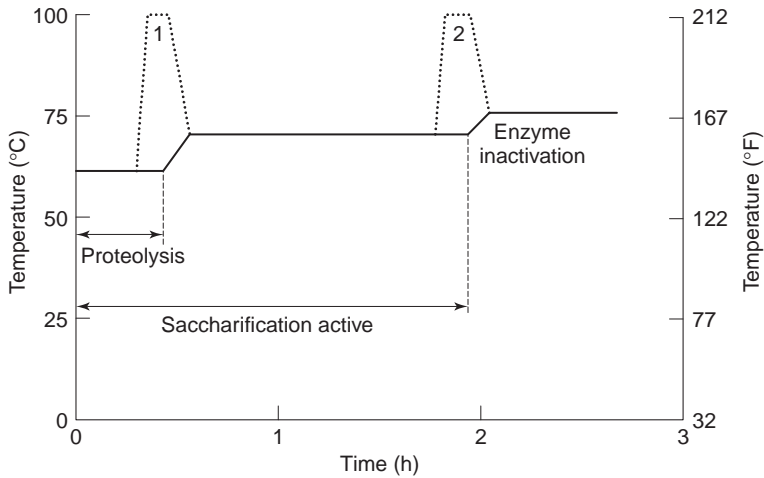

Fig. 4.4 A shortened double-decoction process, lasting about two and a half hours (after Hind, 1950). For the key, see Fig. 4.2. About a quarter of the mash is used in each decoction.

multiplication of unwanted microbes and the development of unwanted flavours. Often the single decoction is coupled with a temperature-programmed period. For example, a mash is made at 35 °C (95 °F), then the temperature is successively raised to 50 °C (122 °F) and then 65–67 °C (149–152.7 °F) with rests at these temperatures. Then about a third of the mash (a thick mash) is taken and heated, with a rest at 70 °C (158 °F), to boiling. This is added back to the main mash, increasing the temperature to 75 °C (167 °F). An interesting variant is where a mash is made at 35 or 50 °C (95 or 122 °F) and after a stand the mash is allowed to settle and the relatively clear liquid, which contains enzymes, is held while the thick mash is stirred and directly heated with rests at 63–65 °C (145–149 °F) and 70–75 °C (158–167 °F), then the thick mash is heated to boiling. This boil will disrupt any solids and gelatinize any remaining starch granules but will inactivate enzymes. Then the thick mash is cooled to 65 °C (149 °F) and is recombined with the thin mash, which provides enzymes to attack the disrupted materials. The recombined mash is initially at about 67 °C (152.7 °F), and is successively warmed, by direct heating, to 70 and then 75 °C (158 and 167 °F). However, the cooling process wastes heat.

Various special mashing programmes are used in Germany (Kunze, 1996; Narziss, 1992a, b). In the jump-mash system (*Springmaisverfahren*), which is used to produce wort with a low fermentability, a thick mash is prepared at 35–40 °C (95–104 °F). Then boiling water is stirred in over a 15 min. period to give a temperature of 72 °C (161.6 °F). By this means the grist is hydrated and some of the thermolabile enzymes have a chance to act before the temperature is increased to permit starch liquefaction and dextrinization while minimizing saccharification. The mash temperature is increased to about 78 °C (172.4 °F) before wort collection. The wort has an attenuation limit of only about 40%. In the Kubessa process the grist is divided into flour, grits and husk fractions. The husk fraction is mashed separately at 50 °C (122 °F) and is held at this temperature while the flour and grits are mashed using a rising temperature programme, with rests at appropriate temperatures, until the mix is boiled. Then the two mashes are combined to give a mixed mash at about 70 °C (158 °F). After a stand the temperature is raised to 78 °C (172.4 °F) and the wort is collected. This process, which is little used, avoids boiling the husk material and gives beer with a better flavour. In the preparation of low-carbohydrate

beers it is necessary to ferment as much of the wort carbohydrate as possible. Where the use of microbial enzymes is permitted this is achieved by adding fungal α -amylase, with or without pullulanase, to the fermenting beer. In Germany highly fermentable wort may be made by using an exceptionally 'intensive' temperature-programmed mash, with rests at 50 °C (122 °F)/30 min.; 62 °C (143.6 °F)/45 min.; 65 °C (149 °F)/45 min.; 68 °C (154.4 °F)/30 min.; 70 °C (158 °F)/30 min.; 72 °C (161.6 °F)/15 min. and then mashing off at 73–74 °C (163.4–165.2 °F). This process takes 3.5–4 h. Even so the wort is not fully fermentable and it is necessary to add powdered highly diastatic malt or malt extract to the fermenting beer. These additions risk contaminating the beer with spoilage organisms.

Decoction mashing is convenient when small amounts of adjuncts need to be cooked, since cooking can be carried out in the decoction vessel. The use of large quantities of adjuncts, such as rice, maize and sorghum grits, that require thorough cooking, combined with the availability of high-nitrogen, enzyme-rich malts gave rise, initially in North America, to the double-mash system. With this two mashes are prepared and then they are combined, often in a third vessel (Fig. 4.5). The adjuncts, which may comprise 25–60% of the grist, are mashed in, in a cereal cooker, with a proportion (5–10%) of a highly enzymic malt (80–200 °L) or a heat-stable bacterial α -amylase, at about 35 °C (95 °F). The temperature is raised to about 70 °C (158 °F) and the malt starch is liquefied and liquefaction of the adjunct starch begins. The temperature is traditionally increased to boiling and is held at this temperature for about 45 min. However, depending on the grist and the enzymes used, it may be preferable to hold the temperature at 85 °C (185 °F), and so save the cost of the fuel needed for boiling. While the adjunct mash is in progress the malt mash is prepared by mashing-in (doughing-in) at about 35 °C (95 °F). After a rest of about one hour the two mashes are combined and mixed achieving a temperature of about 68 °C (154.4 °F). After a stand of 15–30 min., when all the starch is saccharified, the mash is heated to around 73 °C (163 °F) by adding hot liquor or by steam injection, then it is lautered.

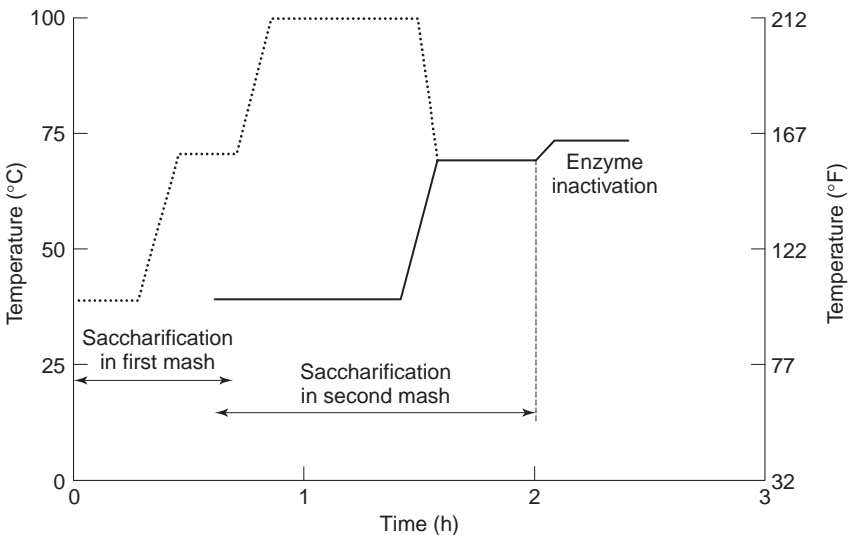

Fig. 4.5 A scheme of the temperatures found in a double-mash programme using a grits cooker (after Hind, 1950). the temperature of the adjuncts/grits mash in the cereal cooker. — the temperature in the malt mash and in the combined mash during and after mixing.

In parts of Africa no barley malt is available and the sorghum malt is not suitable for making lager-types of beers with mashing schedules designed for barley malts (Chapter 16). Under these circumstances mashes have been made with maize or sorghum grits converted with microbial enzymes. Sometimes 10–20% of sorghum malt has been included in these grists to provide soluble nitrogenous materials, but they are virtually ‘all-adjunct’ mashes.

When making some traditional Belgian top-fermented beers the temperature of the infusion mash may be increased by steam injection (De Clerck, 1957). Mashing-in may be at 45–50 °C (113–122 °F) then, after a 30–45 min. stand the temperature is increased to 62–63 °C (143.6–145.4 °F). After another rest of 30–45 min. the temperature is raised to 70 °C (158 °F) and then, after 30–45 min., to 75 °C (167 °F). After a pause wort collection is started. Temperature-programmed infusion mashing is being more widely used both in ale and lager breweries. The rising temperature programmes may be adjusted in many ways, allowing rests at any desired temperature. The stirred mash is heated in one vessel, sometimes with precautions to exclude air, and so the costs of a decoction vessel and heating parts of the mash to boiling are avoided, although an adjunct cooker may be needed. Boiling thick mashes is not practical and so, if undermodified malts or mashes with particular adjuncts are used, the mashing programmes must be extended and it is sometimes necessary to add microbial enzymes. For a mash made with an undermodified malt the temperature/time sequence might be 35 °C (95 °F)/30 min.; 50 °C (122 °F)/30 min.; 65 °C (149 °F)/30 min.; 70 °C (158 °F)/30 min., 75 °C (167 °F)/15 min. then mashing off, with the temperature rising between the rests at the rate of 1 °C (1.8 °F)/min. For mashes being made with better modified malts the programme might start at 48–50 °C (118.4–122 °F) and the durations of the different rests may be varied to achieve the desired quality of wort. Typically these mashes last 2–3 h. Often the mashing programme is chosen to produce a wort that is closely similar to one made by a decoction mashing programme (Hug and Pfenninger, 1979; Fig. 4.6). Temperature-programmed

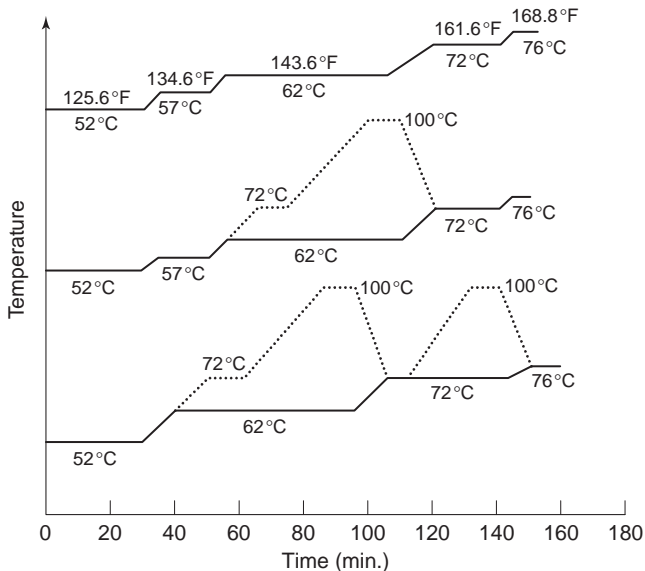

Fig. 4.6 The temperature programmes of three mashes that yield very similar worts (after Hug and Pfenninger, 1979). The uppermost scheme is for a temperature-programmed infusion mash while the central scheme is for a single-decoction mash and the lowest is for a double-decoction mash.

mashing is easily automated and is said to use 30–50% less energy than a similar decoction mashing programme. However, while wort produced by different programmes may often be matched, this is not always the case. Decoction mashes tend to give darker worts with lower TSN levels and higher viscosities due to the non-starch polysaccharides dissolved during boiling. The husks are not boiled in infusion mashing. This is said to improve the flavour of the resultant beer.

Novel ‘mixed’ mashing systems are used in Belgium for preparing some traditional beers (De Clerck, 1957). These involve the use of large amounts of unmalted wheat. In one system the wheat is boiled in a copper, and then cooled and a diastatic extract is added to liquefy the starch. Separately the malt is mashed in a mash tun and the wort is drawn off from the base. The wheat mash is transferred onto the top of the malt mash and the liquid is collected after it has filtered through the layer of malt. Other mashing systems involve producing ‘turbid worts’ by mashing malt and wheat, mixed together, in a mash tun at 50°C (122°F), standing and then collecting the wort and the turbid supernatant in a copper. The re-mashing is repeated two or three more times, using progressively hotter liquor. Each time the wort is added to the copper. The copper contents are heated and held at 70°C (158°F) to saccharify suspended starch. This process, which produces turbid final worts, is needed to give Lambic beer its correct character.

4.3 Altering mashing conditions

4.3.1 The grist

Malt and some adjuncts, such as torrefied wheat, must be broken up before mashing. Until recently this was nearly always achieved by roller milling, but now hammer-milling is sometimes used (Chapter 5). The objective of milling is to break up the grist to give an acceptable range of particle sizes. The acceptable range is determined by the wort separation system being used. Often milling is carried out in such a way as to minimize the break-up of husk material, as husk fragments help to give the mash an open structure and aid wort separation. Indeed, many years ago oat husks were added to mashes to ‘open them up’. Mash tuns require the coarsest grists, followed by various types of lauter tun, and then mash filters. While older types of mash filters required a fine, roller-milled grist the newest designs use hammer-milled grists that are very fine indeed. There are reasons for using the most finely ground grist that can be processed with the equipment available. The finer the particles the faster they hydrate on mashing, the faster the pre-formed soluble substances dissolve and the faster the extract leaches from the particles during sparging. Furthermore, the enzymes have more ready access to their substrates in thoroughly disrupted grists. The surface/volume ratio of a material is larger the smaller and more numerous the particles into which it is divided and so a finely divided grist provides a larger surface area on which enzymes can act and across which substances can diffuse. To varying extents the particles will be pervious, permitting enzymes, substrates and the products of hydrolysis to enter and leave. In practice, finer grinding gives grists that, up to a given ‘degree of fineness’, yield higher extracts (Tables 4.1, 4.2). Finer grinding is less advantageous with better modified malts (this is the basis of the analytical fine-coarse extract difference determination), but it is beneficial with many (perhaps all) mash tun adjuncts.

For many years attempts have been made to find ways of producing worts from finely ground, or ‘pulverized’ grists. Decanter centrifuges, belt filters and rotary vacuum filters

Table 4.1 Average laboratory extract values, obtained from 12 malts mashed isothermally at 65 °C (159 °F) for one hour, using three settings of the Bühler-Miag disc mill. The smaller the gap between the grinding surfaces the finer the grind (Martin, 1979)

Gaps between milling surfaces (mm)	0.2	0.5	0.7
Hot water extract (l/kg)	296.2	293.5	291.4
Confidence limits (95%)	± 2.0	± 1.9	± 1.9

(In a previous trial the HWE values were 305.4, 302.3 and 300.0 respectively.)

Table 4.2 Some analyses of two short-grown, experimental malts and a commercial malt ground with different degrees of fineness (Wackerbauer *et al.*, 1993)

Malts (days germination)	3	5	7 (Commercial)
Friability (%)	62	83	91
Whole corns (friabilimeter, %)	3	2	1
Extract (coarse grind EBC, %)	73.9	78.6	79.7
Extract (fine grind EBC, %)	80.2	80.8	80.9
Extract (hammer milled, %)	[78.6]*	81.4	81.7

*The reason for this atypical low value is not clear. Possibly the mixing in of the very fine grist was uneven.

(used with kieselguhr filter aids) have been tried for separating the wort from the spent grains. The advent of the newest types of mash filters (Chapter 6) has permitted the use of very fine grists. The introduction of very fine grinds necessitates the alteration of the mashing schedule if an established product is to be 'matched'. More finely ground grists are 'converted' more quickly, saccharify faster, give higher extracts and sometimes the worts obtained are more fermentable and less turbid. Narziss (1992b) reported that malts ground coarsely, finely and powdered gave samples with extracts (% dry wt.) of 78.9, 80.7 and 82.4, the worts having real attenuation limits (%) of 66.1, 65.1 and 65.3 respectively. By using very fine grists the whole mashing process can be carried out more quickly and with better extract yields. The levels of TSN and FAN increase and, at least with some grists, the levels of soluble β -glucans increase and wort viscosities increase (Pollock and Pool, 1968; Narziss, 1992a, b; Kunze, 1996). Sometimes the flavour of the beer produced is improved, perhaps because the shortened mashing times allow less poorly flavoured material to be extracted. It may be possible to use a higher proportion of adjuncts in a finely divided grist, and the fine grind is helpful when processing under-modified malts. With modern mash filters the extract recoveries from finely ground grists can equal, or exceed, laboratory extracts.

Malt grists can be fractionated by sieving (screening) and/or by air classification. The fractions have different compositions and yield different worts when mashed separately. So, for example, fine flour derived mainly from the inner starchy endosperm saccharifies well when mashed alone, and yields an exceptionally high extract (e.g. 96%), and gives pale beers with very fine, pure and fresh flavours but lacking in body, low in phenolic tannins and resistant to the formation of chill haze. In contrast the fraction enriched with the outer parts of the starchy endosperm yields more soluble nitrogen, has an extract of about 80%, an intermediate colour and gives a beer that is full bodied and with a fresh flavour but having a harsh, clinging, astringent or bitter after-taste (Kieninger, 1969, 1972). The husk fraction was obtained in smaller amounts. By combining fractions in different proportions different types of beer could be made. Also, by removing part or all of the husk material, brewing with the remainder of the grist would be more rapid, the beers produced would be paler and have a higher haze stability and a 'finer' flavour (Vose, 1979). These fractionation processes take time and involves extra costs and

produce a husk-enriched fraction that needs to be used. Its use in cattle food would seem to be uneconomic and to use it, added to the grist, in the production of 'normal lagers', would compromise their quality. Probably grist fractionation processes are not in commercial use.

By using a high-impact mill, running at a reduced speed, and then fractionating the grist over a 1.60 mm screen Krottenthaler *et al.*, (1999) separated the grist, which initially had an unusually wide range of particle sizes, into 79% finely ground and 21% more coarsely ground. The husk contents of the fractions seemed to be the same, and the extracts were almost identical. However, on analysis the coarse fraction took 55–60 min. to saccharify, compared to the 10 min. by the fine fraction, and the coarse fraction yielded less FAN and total soluble nitrogen but substantially more β -glucan and a more viscous wort. Thus the coarse material was derived from the under-modified portions of the malt. By mashing in the coarse material at 35°C (95°F) then temperature programming to 65°C (149°F) then, after a rest during which starch conversion should have occurred, combining the 'coarse mash' with the mash of the fine fraction, that had been made at 25°C (77°F) in a second vessel, a combined mash temperature of 45°C (113°F) was obtained. After a rest, during which the temperature-sensitive β -glucanase surviving in the fine fraction mash should have operated, the temperature of the combined mash was increased to 65°C (149°F). Then, after a further rest during which the starch from the fine fraction should have been converted, the temperature was increased to 72°C (161.6°F), which was held for a further period, allowing some final α -amylolysis, before lautering. Compared to the standard mashing programme, slightly more extract was recovered using the fractionated grist mash (83.0 compared to 83.5%) the viscosity of the wort was usefully reduced (1.61 compared to 1.52 mPa.s for an 8.6% wort) and the β -glucan content was roughly halved. Such a technique may be attractive where the *Reinheitsgebot* or similar restrictions are in force. A similar result could be obtained more simply by adding a fungal β -glucanase/cellulase preparation to the unfractionated mash.

4.3.2 Malts in mashing

The choice of malts is dictated by the type of beer to be made and by quality considerations. Some qualities of different types of malt are indicated in Chapter 2. The brewer is faced with the problem that malts with the same traditional analyses may be different, and the differences can give rise to major problems in the brewery and in beer quality. Coloured and special malts' flavours change and decline with age and so these materials should be used fresh and their lab worts should be tasted and smelled to see that they are 'normal'. Although chemical 'marker' substances, such heterocyclic, nitrogen-containing Maillard products, have been sought, to allow flavour to be quantified indirectly by chemical analyses, this approach has had little success. Most attention has been paid to pale malts, since these make up the greater part of malt requirements, whether or not adjuncts are also used. In the first place each batch of malt should be as nearly identical as possible to earlier batches of the same type used successfully to make a particular product. This is not necessarily easily achieved. The old belief that some pale malts behave better when mashed after several weeks storage has been confirmed (Rennie and Ball, 1979). The ease of wort separation improves over a period of about three weeks and the clarity of the worts improves, but the reason(s) are unknown.

As the available varieties of barley change the problem arises that they produce different malts when malted in one way. Some varieties give malts that give higher, or lower levels of hydrolytic enzymes, TSN or FAN relative to the yield of extract, or that

give worts differing in fermentability or flavour and so on. Even comparatively small differences between samples of one variety of barley can cause differences during malting and in the quality of the malt produced. Irregularities in germination can lead to inhomogeneity, which is not always easy to detect, and may not be suspected until it has caused problems in the brewery.

Brewers require a malt that mills easily to give the correct ranges of particle sizes, that converts in the 'standard' time to consistently produce their standard wort, and allows easy, rapid and repeatable wort separation from the mash. The recovery of the extract should be as high as the equipment in use allows. These points are particularly important in automated plant and/or where a high, fixed number of brews should be completed each day and there is no spare time. The wort should have the correct characteristics for the beer being made and the beer made from it should be easy to filter and require minimum 'stabilization treatments' (e.g. with silica hydrogel, PVPP adsorbents or additions of enzymes) to minimize haze formation or flavour deterioration and so have a maximum shelf-life. The wort should have all the components the yeast needs to achieve a rapid and complete fermentation.

Brewers require analyses of each batch of malt. Regrettably different brewers have different requirements (Chapter 2). Normally analyses will include moisture content, colour, laboratory extract (HWE or E), total nitrogen (TN; protein), soluble nitrogen (or protein) and free amino nitrogen (FAN, determined by a stated method). Sometimes, and often if adjuncts are being used, they will also ask for estimates of the diastatic power (DP) and α -amylase activity. β -Glucanase estimations may also be required. These are of minimum value if isothermal infusion mashing is being used unless barley adjuncts are included in the grist. However, they can be of use when deciding on the decoction or temperature-programmed mashing sequence to be used with under-modified malts or grists containing barley adjuncts.

The most important analysis is the laboratory extract as, in general, the higher this is the better the quality of the malt. Allowance is made for the nitrogen content, which is inversely related to the extract yield, and for the variety of barley from which the malt is made. High total nitrogen contents are related to better foam characteristics in the beer and to harder malts. An adequate FAN level is needed in a wort to ensure that yeast grows well and that fermentation proceeds rapidly and completely. Too high values are not desired as this can lead to excessive and wasteful yeast growth. Higher values are required for malts that are going to be used together with adjuncts that act as nitrogen diluents as they contribute relatively little or no soluble nitrogen to the wort. Colour, or boiled wort colour, gives a good estimate of the colour of the beer and indicates what colour adjustment may be needed.

Other tests are now often used in attempts to overcome the deficiencies of the traditional analyses (Briggs, 1998). Heterogeneity may be determined by scoring stained grain sections or by the determination of partially unmodified grains using the friabilimeter. The friability of the grain indicates the type of result that will be obtained when the malt is milled. Wort β -glucan may be determined as may the residual β -glucan in the malt and the viscosity of the wort. High values for fine grind-coarse grind laboratory extract differences indicate that malts are under-modified and that they may give rise to brewing problems (Table 4.2). At least one brewery has found that the fine grind, coarse grind and concentrated mash extract difference and the total malt β -glucan content are inversely related to extract recovery in the brewhouse and that the viscosity of wort from a 70 °C laboratory mash is correlated with the viscosity of strong brewery worts and so high values give warning of possible beer filtration problems and the

occurrence of β -glucan hazes and gels (Bourne and Wheeler, 1982, 1984; Bourne *et al.*, 1982). In another brewery, using traditional ale isothermal infusion mashing, the extract recoveries in the brewery were correlated with the hot water extracts and fine-grind-coarse-grind extract differences. So, from the laboratory measurements it was possible, by entering the values in the appropriate equation, to predict the brewhouse yield of extract (Maule and Crabb, 1980). Many correlations between laboratory analyses and brewery performances have been reported, but the correlation coefficients seem to vary significantly or to fail in different years and/or not to be applicable to different breweries. Thus the performance of each brewing line needs to be evaluated and ways to predict its performance need to be assessed individually.

‘Problem malts’, malts which give rise to brewing difficulties, are usually characterized by their ‘wrong’ degrees of modification, either in all the grains or in a proportion of the grains, when the malt is inhomogeneous. As noted, the ‘correct’ malt characteristics vary with the way it is to be used. In addition to inadequate enzyme levels under-modified malts are characterized by the inadequate breakdown of the endosperm cell walls. These unmodified regions resemble raw barley, and the problems associated with their presence resemble the difficulties encountered when raw barley is used as an adjunct. They are tough and, when the malt is milled, they give rise to coarse grits. The intact cell walls contain β -glucan and pentosans and, as they ‘box in’ the starch and protein of the cells, these are not degraded because enzymes cannot pass through the cell walls except where these are disrupted by milling or heating, as in decoctions. So undermodified malts give low extract recoveries, and the worts are often poorly fermentable. The levels of soluble nitrogen are low, the worts are viscous and rich in β -glucans and wort run-off is slow. The β -glucans may, or may not, deposit as gels or give rise to hazes, but they always seem to give difficulties with beer filtration. These problems can be minimized by adding microbial enzymes to the mash. In addition the beers may show protein-polyphenol haze and flavour instabilities. Nor are over-modified malts desirable. Besides the high malting losses accumulated during their production these give rise to too powdery grists when the malts are milled (impeding wort run-off) and although the yield of extract is good the quality can be poor. In particular the beer made from this malt is likely to lack body, the flavour may be poor, and the foaming characteristics will be bad.

Different types of malt have different characteristics. For example, the more highly cured a malt is the lower its enzyme content (Table 4.3). The extract is slightly reduced by more curing, and the levels of soluble nitrogen are reduced, as shown by the decline in the nitrogen index of modification. S-Methyl methionine, SMM, the precursor of dimethyl sulphide, DMS, is destroyed and so kilning may be used to regulate the levels of this compound. The fermentability of the wort is reduced, giving beer with a lower alcohol content and more residual carbohydrate. The colour of the worts from more highly kilned malts are darker. Crystal malts and black malts are enzyme free and their inclusion in a mash reduces the fermentability of the wort. In making low-alcohol beers it is usual to mash well-cured malts with caramel malts at high temperatures to minimize saccharification, and so reduce the production of fermentable sugars. In addition experiments have been made in steaming green malts to cause enzyme destruction before kilning (Briggs, 1998). Curiously, the use of malts dried at low temperatures (40°C, 104°F) to a moisture content of 7–8%, which have high enzyme contents, seems not to occur although the reduction in kilning costs should make them less expensive. The use of undried, ‘green’ malts is impractical in production brewing. Malts made with barleys containing a mutation that prevents the formation of anthocyanogen

Table 4.3 Some effects of malt kilning on wort and beer analyses. The green malt was freeze dried before analysis. The kiln-dried samples were removed at successive stages of kilning (data of MacWilliam, 1972)

	Freeze-dried	Lightly kilned	Kilned	Strongly kilned
Malt properties				
Colour	–	3	6	13
Moisture (%)	41.3*	3.7	2.9	2.3
Hot water extract (lb/Qr)	104.0	102.9	102.2	101.9
(1%kg) [†]	308	305	303	302
Cold water extract (%)	19.4	19.5	19.1	17.1
Diastatic power (°L)	131	98	68	48
Total nitrogen content (%)	1.59	1.55	1.56	1.47
Index of nitrogen modification (%) [‡]	43.7	43.9	41.6	38.7
[* Moisture content before freeze drying. [†] Approximate equivalents to the values in the older units. [‡] PSN/TN].				
Beer properties				
Total carbohydrate (g/l)	13.3	16.7	21.6	27.4
Residual fermentable sugars (g/l)	1.1	2.8	1.3	4.8
Non-fermentable carbohydrate (g/l)	12.2	13.9	20.3	22.6
Total soluble nitrogen (mg/l)	526	645	593	580
Bitterness (EBC units)	22.3	25.8	22.6	23.6
Head retention (half-life, seconds)	91	106	93	101
Colour (EBC units)	12	15	17	27
Flavour (bottled)	'Green malt'	'Lager-like'	'Pale ale'	'Mild ale'

polyphenols, which contribute to the formation of protein-tannin hazes, give beers that are extremely resistant to haze formation, are in limited use. However, proposals to make malts from low β -glucan barley mutants or barleys that have been genetically modified to contain more heat-stable α -amylase or β -glucanase have not been carried out. In part this may be due to the sentiment opposing the use of genetically modified materials in brewing.

Several brewing problems are associated with microbial infections of malts. Off-flavours may occur and there is always the concern that mycotoxins may be present on poor malts. Particular attention has been paid to the possible presence of aflatoxins, ochratoxin, zearalenone, deoxynivalenol, fumosins and citrinin, which can be produced by a range of fungi infecting barley (Scott, 1996). Some, such as citrinin, do not survive the brewing process, but others, such as deoxynivalenol, can survive into beer. Fungi also produce factors that cause gushing (over-foaming) in beers. The solution seems to be to avoid making malts from cereals that are heavily infected with fungi. Fungal infections are a considerable problem in tropical areas. High levels of bacteria on malt can also give problems. Bacteria multiply very greatly during malting, especially on the substances leached from split grains. Malts made with heavily infested barleys have, on mashing, given rise to very slow wort filtrations, possibly due to microbe-produced polysaccharides clogging the grain bed. Other malts have given worts having persistent hazes due to suspended dead bacteria, about 0.6 μ m in diameter (Walker *et al.*, 1997). Another problem caused by microbial infestations of malts are the wild, and unpredictable fluctuations in the pH of worts (e.g. pH 5.45–6.06; Stars *et al.*, 1993). Multiplication of lactic acid bacteria on the growing malt and particularly in the initial stages of kilning high-moisture

green malts, was largely to blame. The malting process had to be modified to minimize this problem.

The most uniform homogeneous malts are made by malting grain of one variety and one grade. However, successive batches of malt, made to meet one specification inevitably differ slightly and so they may be mixed, or 'blended', to meet a brewer's specification. Many European brewers regard blending malts of one grade but made from different barleys as unacceptable, even though in some other areas mixtures of barleys are malted. Brewers commonly mix different malts (pale, caramel, brown, etc.) to obtain the mix appropriate for a particular beer. Narziss (1991, 1992a) gives examples of malt mixtures used to make many European types of beers. At the start of a new season the old season's malt, of any type, will increasingly be diluted with the new season's malt of the same type so that any consequent small differences in beer quality will not be noticed. Some types of blending are never acceptable. For example, suppose a beer is made with a coloured malt to give a colour 10. If the usual coloured malt is not available it is not acceptable to blend 50 : 50 two malts of colours 5 and 15. The colours may match in intensity (but probably not quality) but the flavour of the product will not match the original, since the 'average' mix of flavour substances will be different from that in the original malt. When two similar malts are blended it is necessary to be able to predict the wort quality that the blend will give (Moll, *et al.*, 1982; Yamada and Yoshida, 1976). In general the extract and FAN values of mixtures vary linearly between the values of the individual malts according to their proportions in the mixtures. But the fermentabilities of the worts will be better than predicted from simple proportions (synergism is shown) as enzymes from the more enzyme-rich malt partly compensate for the inadequate levels in the other. Since in one case the increase above the fermentability was due to increased levels of maltose and maltotriose this could have been due to the activity of limit dextrinase.

4.3.3 Mashing with adjuncts

The characteristics of commonly used adjuncts are summarized in Chapter 2 and Briggs (1998). Like special, highly coloured barley malts mash tun adjuncts are deficient or totally lacking in the enzymes needed to convert the starch or degrade nitrogenous substances during mashing. Like the unmodified regions of pale malts, and especially chit malts, many adjuncts retain their cellular structure which must be disrupted by cooking or milling to allow enzymes access to the starch and protein during mashing. Malt extracts, sugars and syrups may be used as copper adjuncts to provide more extract, to create high-gravity worts, to 'dilute' soluble nitrogen and to adjust wort fermentabilities. In general, adjuncts are used to provide relatively inexpensive extract, to modify beer character (often resulting in less body, a more 'delicate' and bland flavour or a less strong character), and to dilute the levels of lipids, polyphenols and soluble proteins from the malt giving a more haze-resistant, and sometimes more flavour-stable beer and to improve the head of the beer (Briggs, 1998; Martin, 1978).

The proportions of adjuncts used in mashes vary widely, even within one country. In Bavaria no adjuncts may be used, in the UK 0–25% of wort extract may be derived from adjuncts (including copper adjuncts), while in the USA and Australia levels of 40–50% are common and sometimes may be higher. It is not possible to switch between adjuncts at will because the handling equipment and processing conditions that each require are different. Mash tun adjuncts can cause some brewing problems and extra costs, including the need for extended mashing schedules and/or the provision of a cereal cooker, the need for additions of microbial enzymes, slow wort separations and difficulties with beer

filtration. As the proportion of adjunct in the mash increases so, at some stage, the quantities of enzymes available from the malt become inadequate for achieving a good starch conversion, and the recovery of extract declines, the fermentability of the wort falls, the levels of soluble nitrogen and free amino nitrogen, and even some inorganic substances may fall to such a level that yeast growth and fermentation may be impaired. In North America, using the double-mashing system (Section 4.2), up to 60% of maize or sorghum grits may be used in conjunction with highly enzymic, nitrogen-rich malt. Even with this system it may be advantageous to use microbial enzymes, such as heat-stable α -amylase, to liquefy the grits in the cooker or a fungal saccharogenic amylase, pullulanase or amyloglucosidase to adjust wort fermentability.

Green malt, used experimentally in simple infusion mashes, can convert large proportions of adjuncts exceptionally well giving highly fermentable worts with low levels of proanthocyanidins that give highly haze-resistant beers (MacWilliam *et al.*, 1963; Briggs *et al.*, 1981). However, the difficulties of handling green malt, coupled with 'raw-grain' flavour, have prevented this being used. In practice, highly enzymatic, high-nitrogen pale malts made from selected varieties of barley, are best for converting adjuncts (Allen, 1987; Halford and Blake, 1972).

The adjuncts used in simple infusion mashes either contain starches with low gelatinization temperatures or have been pre-cooked to pre-gelatinize the starch. These include raw barley, (sometimes regarded as the 'natural adjunct'), wheat flour, torrified barley or wheat and flaked maize or rice grits. In addition, flaked barley or wheat may be used. Flaked maize and flaked rice were very popular with British brewers, but they are little used now, because of their costs. Some pre-cooked cereals give lower extracts than expected because during cooking some of the amylose is induced to crystallize and so become enzyme-resistant (Home *et al.*, 1994). Provided that adjuncts are not used in excessive amounts, they are well mixed in with the malt at mashing in and the malt contains an adequate level of enzymes, they are relatively easy to use. The torrified grains can be milled with the malt. However, raw barley is tough and may need to be wet-milled or ground separately in a specially adjusted mill. 'Barley brewing' is considered later. Wheat flour, like raw barley, can slow wort separation to a serious extent and although it has been used at malt replacement levels of up to 36% (Briggs *et al.*, 1981; Geiger, 1972), in conventional infusion mashing levels of 5–10% are more usual. The inconvenience of the slow wort separation is partly offset by enhanced head formation and beer stability. Wort filtration problems are reduced by grinding the wheat more coarsely, (e.g by hammer-milling it with a 2–3 mm screen) and by adding a mixture of pentosanase and cellulase enzymes to the mash (Forrest *et al.*, 1985).

Highly purified wheat starch is not troublesome but the technical grade usually used has associated protein and other materials which slow run-off. Higher extracts are recovered if wheat starches or flours are pre-soaked or pre-cooked at about 85°C (185°F) to allow gelatinization and liquefaction. The material is not boiled to avoid frothing. The flours are mashed-in at cool temperatures to avoid clumping. Raw barley, flaked barley and, to a lesser extent, torrified barley, like under-modified barley malts, release β -glucan into the wort. This is associated with (but is not necessarily the major cause of) slow wort separation, but it causes worts to be viscous, it slows beer filtration, and sometimes causes hazes and the separation of polysaccharide gels from strong beers. To minimize these problems it is necessary to use malt containing adequate levels of β -glucanase, or to add microbial β -glucanase or cellulase to the mash (Crabb and Bathgate, 1973). In temperature-programmed mashing an appropriate low-temperature rest is used to allow the malt enzyme to act, or a heat-stable microbial β -glucanase or cellulase can be added to the mash.

In double-mashing the adjuncts used are usually maize-, or rice-grits, although sorghum grits, cleaned sorghum grains and other cereal preparations can be used. Rice grits tend to give a 'drier' character to a beer, while maize grits confer a 'rounder' and more 'full' impression. Cooking is essential when the adjuncts have starches with high gelatinization temperatures (Table 2.3). Rice grits and flours are very variable in their qualities and cooked viscosities may vary 100-fold and run-off times three-fold (Teng *et al.*, 1983). Rice grits are, perhaps, the most difficult adjuncts to use. On cooking, a rice-mash may set to a gel and become unmanageable. Sometimes it may be possible to buy rice of a named variety, having favourable brewing characteristics, but often this is not possible, as only mixtures of rices of unnamed varieties are available. Extract recovery is inversely proportional to the gel point, so a measurement of the latter can be used to give an indication of the brewing value of a batch and how it should be mashed (Teng *et al.*, 1983). If barley malt is the source of the liquefying α -amylase then at temperatures over 78°C (172.4°F) the enzyme is quickly inactivated while some of the starch will not have been gelatinized. It may be necessary to employ complex mashing schedules with heating, cooling and decoctions and more than one addition of malt (Kunze, 1996; Narziss, 1992a). Where the use of microbial enzymes is permitted the rice-mash may be supplemented with a calcium salt (e.g. 100 mg Ca/litre) and the pH adjusted to 6.0. Then a heat-stable bacterial α -amylase is added and the mixture is heated, with a rest at the best temperature for the enzyme (e.g. 85°C; 185°F) to boiling. It may be preferable, and more economic, to use two enzyme preparations, a less expensive preparation of α -amylase with a comparatively low temperature optimum (75°C; 167°F) and a thermostable enzyme with an optimum temperature of 90°C (194°F), and then carry out the heating with rests at the two temperature optima. Cooking may be carried out under pressure, but at the elevated temperatures attained unwanted flavours, involving the formation of sulphur compounds, may be formed. At the end of the cooking period the pH should be adjusted to about 5.5, before mixing with the malt mash.

Sorghum and maize grits are used as adjuncts with barley malt mashes. In some areas of Africa there is pressure to use indigenous cereals to make beers and the use of imported barley malt has been restricted or prevented. Some clear, lager-style beers have been made using malted sorghum. The poor and irregular quality of this material and the high gelatinization temperature of its starch combined with a deficiency of desirable enzymes means that microbial enzymes are routinely used in making most or all of the commercially prepared beers (Demuyakar *et al.*, 1994; Hallgren, 1995; Lisbjerg and Nielsen, 1991; Little, 1994; MacFadden, 1989; Muts, 1991; Chapter 16). Since added enzymes are needed it is economic to use little or no sorghum malt and to mash exclusively with whole sorghum grains or sorghum grits and/or maize grits. With these mashes it is necessary to use mash filters for wort separation. The composition of sorghum grains is very variable, but may yield extracts of about 70%. Grits can yield an extract of over 90% and, at 1%, their lipid content is less than that of the grains at about 3.5%. It is best to use pale grains. If the tannin-rich, coloured, 'birdproof' types must be used then they should be given an alkaline wash with calcium hydroxide, sodium hydroxide or ammonia solutions to extract as much tannin as possible or a formaldehyde wash may be used to bind the tannins, although this is now disliked. Failure to control the tannins results in the inhibition of enzymes during mashing and possibly flavour problems.

Sometimes a proportion of sorghum malt is included in the mashes to enhance the levels of assimilable nitrogen in the wort (Bajomo and Young, 1993). When making an all-grits mash the problem is to obtain the maximum extract, having the correct degree of fermentability, with an adequate level of FAN to support yeast growth and fermentation.

This is achieved by a careful choice of enzymes and temperature programmes. For example, the grits suspension is adjusted to pH6, and a calcium salt is added at 50 °C (122 °F; Lisbjerg and Nielsen, 1991), followed by an addition of a thermostable bacterial α -amylase. The mash is heated to 76 °C (168.8 °F) then, after a 15 min. rest, is heated to boiling and is boiled for 30 min. It is then cooled to 52 °C (125.6 °F) by adding cold water. Then preparations of a protease and a saccharogenic fungal amylase are added. Following a 60 min. rest the pH is adjusted to 5.5, then the temperature is raised to 60 °C (140 °F) and this is held for 60 min. Finally, after increasing the temperature to 78 °C (172.4 °F) and a 10 min. hold, the mash is filtered. Such worts, if no sorghum malt has been used, are deficient in assimilable nitrogen and minerals and so need to be supplemented with 'yeast foods' or autolysed yeast and perhaps mineral salts, including zinc, to achieve good fermentations.

In the 1970s efforts were made to use increasing amounts of raw barley as an adjunct. Moderate amounts of various barley adjuncts are still used, but the use of 70%, or more, raw grain mashes (with attempts to use 100%), has been discontinued. The problems encountered in developing 'barley brewing' can be summarized as difficulties in milling, inadequate extract recoveries, poorly fermentable worts, insufficient levels of assimilable nitrogen, poor foaming characteristics of the final beers, problems due to high levels of β -glucans (slow wort separation, viscous worts, slow beer filtration, hazes and gel formation), higher wort pH values, lack of the correct beer characters and colours and the need for microbial enzymes and excessively long mashing times. On the other hand hop utilization increased when the worts were boiled and the beers were more resistant to haze formation. The barley had to be carefully screened and cleaned (and sometimes washed), and preferably had a low nitrogen content. Some varieties were preferable to others but inexpensive feed-grade grain might be used. In general the use of up to 50% barley in grists was regarded as successful, but the use of larger proportions seemed to increase the problems unduly. Wet milling was widely employed but dry milling of moisture conditioned grain and other methods were used (Wieg, 1987; Allen, 1987; Button and Palmer, 1974; Brenner, 1972).

Various enzyme mixtures were employed. The α -amylase, β -glucanase and protease mixture from *Bacillus subtilis* was widely used. Wort fermentabilities were adjusted with additions of fungal saccharogenic amylase, pullulanase or amyloglucosidase or the use of higher proportions of pale, enzymic malts. Since that time other useful enzymes have become available. A successful mashing schedule, using 70% raw barley and additions of bacterial enzymes, involved wet milling and adding enzymes at mashing-in, which was at room temperature. Then the temperature was increased to 50 °C (122 °F). This was held for 60 min. Further increases were followed by rests at 63 °C (145.4 °F)/75 min., 65 °C (149 °F)/40 min., 68 °C (154.4 °F)/20 min. and then, after heating to 75 °C (167 °F) transferring to the lauter tun (Button and Palmer, 1974). The duration of this process was about five hours, which is too long to be economic for many breweries.

4.3.4 The influences of mashing temperatures and times on wort quality

A knowledge of the influences of mashing temperatures and times is essential to allow the logical choice of mashing conditions. The results of studies, made over many years, do not agree exactly. This is to be expected since different malts, grinds and thicknesses of the mashes were used. This section concentrates on all-malt mashes. Relative to laboratory mashes, brewery mashes are more concentrated (have a lower liquid/grist ratio), they are made with different degrees of milling, with salts in the brewing liquor

and sometimes with pH adjustments. Under brewhouse conditions many key enzymes remain active for much longer than expected from laboratory studies. Some enzyme inhibition can occur through product inhibition and a limiting supply of 'free' water (see next section). The simplest mashes are isothermal, and these are considered first. In production mashing, temperatures are often adjusted to allow temperature-sensitive enzymes to act before the temperature is increased to destructive levels. Temperature adjustments may be achieved by direct steam injection, underletting, decoctions, direct heating through the walls of the vessel, or the addition of hot water. At the end of the process, during wort recovery, the temperature is increased by the hot sparge liquor.

Increasing the mash temperature increases the rate of chemical and enzyme catalysed reactions, accelerates the rates of denaturation and precipitation of proteins (including the inactivation of enzymes), accelerates dissolution and diffusion processes, accelerates mixing and, at least above a certain temperature, causes the gelatinization of starches and (at least during decoctions and adjunct boiling) disrupts the cellular structure of unmodified cereal endosperm tissues. Mixtures of enzymes are active in mashing and these have a range of widely different temperature sensitivities. Enzyme activities decline as mashing proceeds, and so the temperature 'optima' occur at lower temperatures as mashing proceeds (Fig. 4.1). Figures 4.7 and 4.8 illustrate that the optimum temperature for the production of permanently soluble nitrogen, which is dependent on a mixture of enzymes, alters with the pH. Some of the substances extracted during mashing are preformed in the malt. These may or may not be altered as mashing proceeds and they are joined by materials solubilized by enzyme-catalysed hydrolytic reactions. Some estimates of temperature optima are shown in Table 4.4.

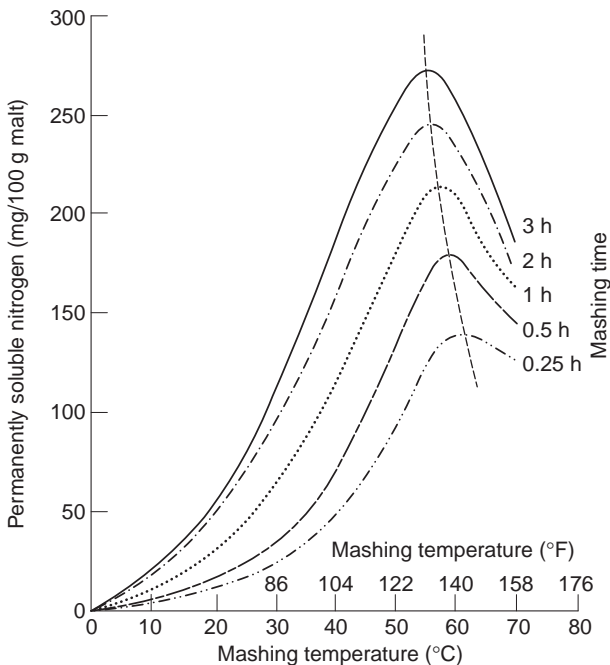

Fig. 4.7 The influence of mashing time on the temperature optimum of the production of permanently soluble nitrogen (data of Windisch and Kolbach; after Moll *et al.*, 1974). With increasing incubation time the temperature 'optimum' declines (compare Fig. 4.1).

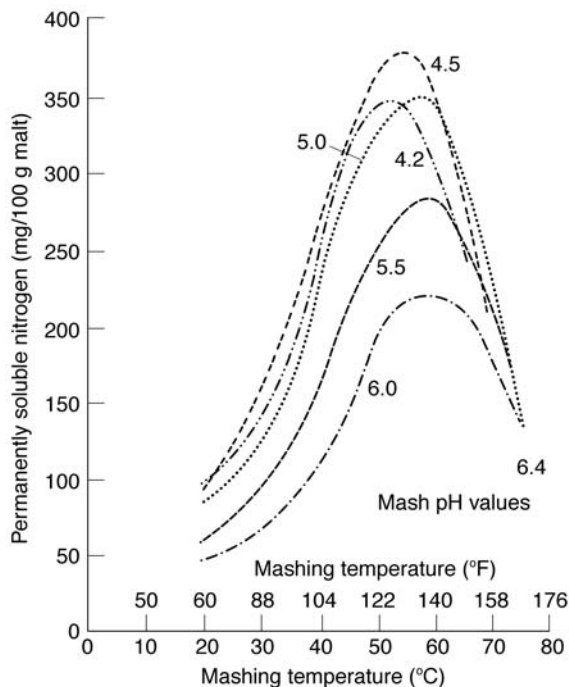

Fig. 4.8 The influence of mashing temperature on the pH optimum of permanently soluble nitrogen formation (data of Windisch and Kolbach; after Moll *et al.*, 1974).

Table 4.4 Temperature optima for some mash processes, carried out for 2–3 h. Data from various sources (Briggs *et al.*, 1981; Hind, 1950; Hopkins and Krause, 1947). The values can be substantially different under different mashing conditions

Process	°C	°F
Highest extract (mainly starch conversion)	65–68	149–154.4
Fastest saccharification (dextrinization)	70	158
Highest yield of reducing sugars	60–63	140–145.4
Highest yield of fermentable extract	65	149
Highest percentage fermentability (%)	63	145.4
Highest yield of permanently soluble nitrogen (Mash times 1–3 h. Higher temp. optima for more concentrated mashes)	50–55 (60)	122–131 (140)
Highest yield of formol-nitrogen	50–55	122–131
Highest PSN <i>minus</i> formol-N	55–60	131–140
Highest yield of ‘acid buffers’	45–55	113–131
Maximum activity of α -amylase	70	158
Maximum activity of β -amylase	60	140
Maximum activity of β -glucanase	40	104
Maximum activity of phytase	50–60	122–140

As noted previously, these optima are not true ‘constants’. At mashing temperatures the survival and activity of the proteolytic system of enzymes is extremely dependent on mash thickness. α -Amylase is less stable and both β -amylase and limit dextrinase are more stable than might be predicted from their behaviours in pure solutions. Most of the extract formed during mashing comes from the conversion of starch to a mixture of

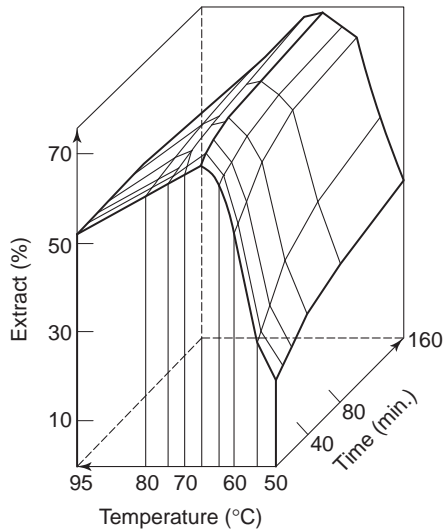

Fig. 4.9 The interrelationships between the yields of extract, the mashing duration and the mashing temperature (after Schur *et al.*, 1975).

soluble sugars, oligosaccharides and dextrans. It is not true that starch can be converted only at or above its gelatinization temperature, although this occurs most rapidly after the granules have been disrupted. It has been known for many years that in mashes made at 55 °C (131 °F) over 90% of the potential extract can be recovered in two hours, although this temperature is well below the gelatinization temperature of barley starch (Table 2.3). Even at lower temperatures some starch conversion occurs, so malt enzymes can slowly degrade malt-starch granules (Fig. 4.9). When the time-courses of extract and permanently soluble nitrogen formation are followed it is seen that in a mash made at 65.5 °C (150 °F) the extract rises rapidly at first and most of the extract has been recovered in one hour but, in this instance, the maximum is not recovered until after 1.5–2 h. (Table 4.5). This limit is set by the nearly complete solubilization of the starch. In contrast the extract of the 49 °C (120.2 °F) mash is still rising after three hours, and extract recovery is not nearly complete. The amount of nitrogen solubilized during mashing never approaches all the nitrogenous substances in the malt, so the halt in the rise in PSN in the 65.5 °C mash after about two hours is due to enzyme inactivation. In the 49 °C mash the PSN is still increasing after three hours, and the value exceeds that achieved at 65.5 °C, proving that a depletion of initially insoluble nitrogenous materials is not limiting. Even in three hours at 49 °C less than 40% of the total nitrogen has been

Table 4.5 Changes in yields with time of extract and permanently soluble nitrogen (PSN) in mashes made at two different temperatures (data of H. T. Brown, *via* Hind, 1950)

Time (min.)	15	30	60	90	120	180
Mash at 49 °C (120 °F)						
Extract (%)	20.3	24.8	28.2	30.3	34.0	37.1
PSN (% TN)	24.6	28.0	32.2	34.6	36.5	39.0
Mash at 65.5 °C (150 °F)						
Extract (%)	63.4	67.1	69.4	69.7	69.7	69.0
PSN (% TN)	27.7	30.7	32.9	33.7	34.6	34.6

Table 4.6 Extracts and fermentable extracts obtained in isothermal mashes during different incubation periods. (Data of Windisch, Kolbach und Schild, via Hopkins and Krause, 1947)

Mashing period (min.)	15	30	60	120	180
60 °C (140 °F)					
Extract (%)	50.2	53.4	57.2	60.7	62.2
Fermentable extract (%)	36.0	39.0	43.1	47.9	50.2
65 °C (149 °F)					
Extract (%)	60.6	62.2	62.8	63.6	63.6
Fermentable extract (%)	44.2	46.6	48.5	50.7	51.7
70 °C (158 °F)					
Extract (%)	61.2	62.5	62.9	63.4	63.6
Fermentable extract (%)	40.9	42.0	41.6	42.2	42.7

brought into solution. However, extract recoveries can be nearly complete at temperatures as high as 80 °C (176 °F), but fermentability may be as low as 30%, compared to 70%, or more, in worts from mashes made at 65 °C (149 °F) (Fig. 4.13 on page 117; Muller, 1991).

At 80 °C (176 °F) sufficient α -amylase remains for starch liquefaction and partial dextrinization to occur while β -amylase and other heat labile enzymes are so rapidly destroyed that little saccharification can take place. In Table 4.6 the maximum extract recovery was nearly achieved in three hours, mashing at 60 °C (140 °F) and was achieved in about two and a half hours at 65 and 70 °C (149 and 158 °F). On the other hand the fermentable extract was still rising after three hours in the lowest temperature mash, was rising more slowly in the 65 °C (149 °F) after three hours, but had stopped increasing between one and two hours in the mash made at the highest temperature. Thus mash temperatures must be very carefully controlled if worts of one quality are to be produced. When the extract yields of isothermal mashes, made at temperatures between 0 °C (32 °F) and 80 °C (176 °F), are compared it is seen that the extracts increase relatively little with increasing temperature until 45–50 °C (113–122 °F) is reached. Then extracts rise sharply with increasing temperature up to about 55–60 °C (131–140 °F), then the rate of increase falls sharply and the maximum is achieved at 62–66 °C (143.6–150.8 °F). At higher temperatures there is a slow decline in extract recovery, at least up to 80 °C (176 °F; Windisch *et al.*, 1932). The relationship between extract yield and a more narrow temperature range for different times is shown in Fig. 4.9. By using different series of increasing temperatures, in temperature-programmed mashes, wort composition can be adjusted to a useful extent, for example, to produce beers with different alcohol contents.

Mashing for extended periods at low temperatures favours the formation of soluble nitrogen, the optimum temperature depending on the time (Fig. 4.7). Carbohydrates are the main contributors to extract. The formation of the major groups of carbohydrates during a temperature-programmed mash are illustrated in Fig. 4.10 (Enevoldsen, 1974). Notice that starch hydrolysis must have begun before the temperature reached 63 °C (149 °F). The 'rest' temperatures used in mashing are chosen with reference to the temperature optima of key groups of enzyme-catalysed reactions. The low-temperature rests at about 45–50 °C (113–122 °F) are needed with undermodified malts when the breakdown of proteins and β -glucans is to be encouraged. The rests at about 65 °C (149 °F) are to maximize starch conversion and production of fermentable sugars. The fermentable group of sugars includes glucose (4.1), fructose (4.2), sucrose (4.3) and maltotriose (4.5), but the major component is maltose (4.4). The non-fermentable

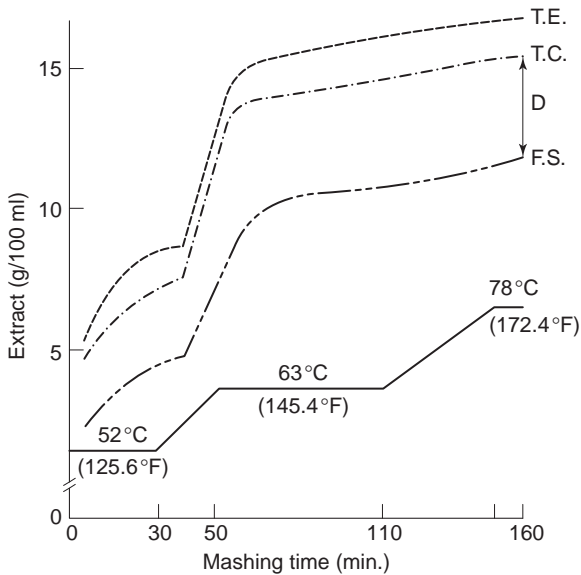

Fig. 4.10 Changes in the yield of total extract (TE), the yield of total carbohydrate (TC), the fermentable sugars (FS) and the unfermentable dextrins (D) during a temperature-programmed mash (after Enevoldsen, 1974).

carbohydrate fraction is chiefly a complex mixture of dextrins. Mannose (4.8) and galactose (4.9) are not released into solution. The extract increases at 52°C (125.6°F) but increases much more rapidly as the temperature increases to 63°C (145.4°F) and is held at this temperature. It continues to increase slightly up to the final temperature of 78°C (172.4°F) (Fig. 4.10).

The changes that occur in yields of soluble nitrogen during temperature-programmed mashing are illustrated in Fig. 4.11. In the mash made at 35°C (95°F) the highest level of TSN was achieved after about 100 min., then as the temperature continued to increase the level fell, due to the denaturation and precipitation of solubilized proteins. Beginning the programme at a higher temperature, 50°C (122°F) yielded the same final amount of TSN at the end of the mash, but mashing in at 65°C (149°F) reduced the final amount of TSN significantly. The amounts of amino nitrogen formed fell as the mashing in temperature increased, so the mixture of nitrogenous substances in solution was altered by changes in the mashing regime. This result is due to the different temperature sensitivities of the enzymes involved. Prolonged mashing regimes are usually needed when under-modified malts are used, and the advantage in terms of yield of TSN is also shown in Fig. 4.11.

The production of amino acids (measured by two methods) during a different temperature-programmed mash is shown in Fig. 4.12. It was long believed that proteolysis in mashing ceased at temperatures above about 60°C (140°F). This is not so. Proteolysis is most rapid at lower, 'conventional' protein rest temperatures, but it does not cease immediately the temperature rises. At these lower temperatures phytase and β -glucanase also continue to act. By mashing a malt in different ways worts with different qualities are produced (Table 4.7). By encouraging proteolysis the colours of worts are increased, probably because the elevated levels of nitrogen-containing substances favour melanoidin formation during the copper boil. More complete proteolysis reduces the amount of trub formed and this enhances the hop utilization, since less of the bitter substances are deposited with the coagulated protein (trub). Less trub (sludge) is formed

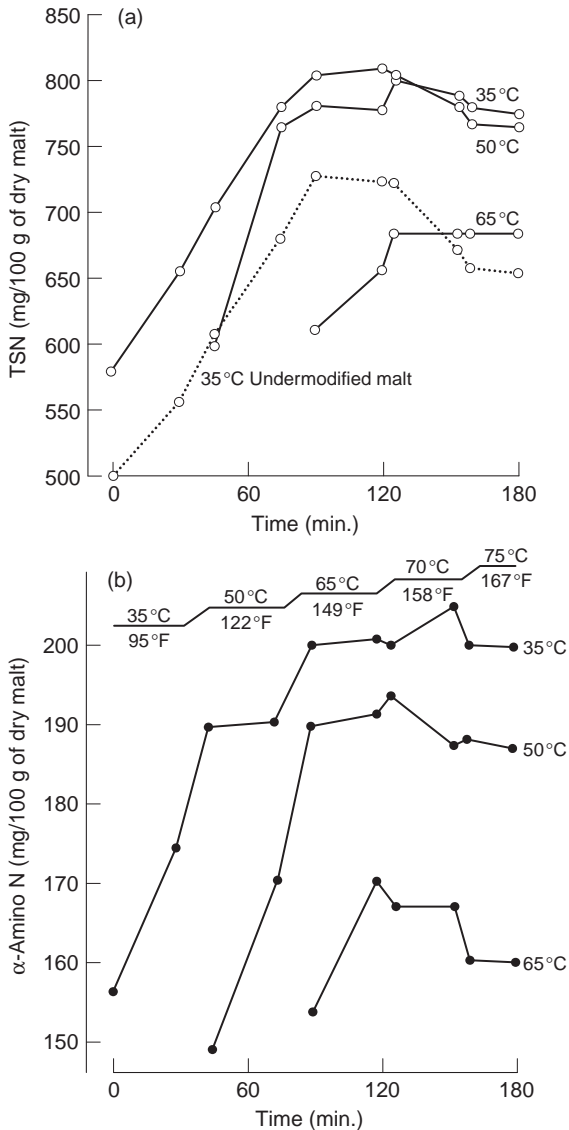

Fig. 4.11 Increases in the levels of the (a) total soluble nitrogen and (b) the α -amino nitrogen during temperature-programmed mashing. The different mashes were started at the temperatures shown and then the programme was completed (after Narziss, 1977). The discontinuous line in (a) shows the results obtained with a different, undermodified malt.

in worts from decoction mashes, probably because some of the protein has been denatured and precipitated in the boiled parts of the goods.

4.3.5 Non-malt enzymes in mashing

The mainly microbial, non-malt enzymes used in brewing are indicated in Chapter 2. In this section only the addition of enzymes to mashes is considered. Because of the absence of agreed methods of assay and the presence of 'extra' unspecified and/or unquantified

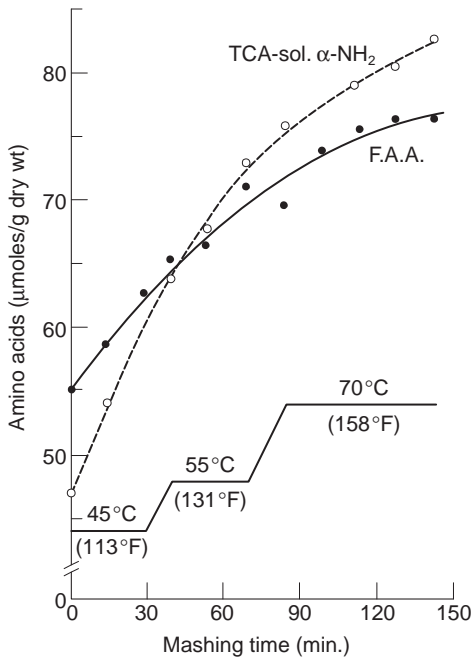

Fig. 4.12 The formation of amino acids during a temperature-programmed mash (after Enari, 1974). The 'amino acids' were estimated in two different ways, which gave discordant results. Although amino acid liberation proceeded fastest at low temperatures it was still going on at the end of the mash at the highest temperature. (FAA, free amino acids; TCA sol- α -NH₂, amino groups soluble in trichloroacetic acid.)

enzymes in enzyme preparations it is essential that brewers test each preparation on the laboratory and pilot-plant scales before introducing it into the brewhouse. The dose-rate is critical for achieving a particular result, and this must be financially worthwhile. Difficulties arise when a preparation that has been correctly standardized on one enzyme activity is used but the activity of an important 'secondary' enzyme differs between batches or declines at a different rate during storage. It is possible to store particular preparations at 'room temperature' for some months but in principle, all enzyme preparations should be stored cold to minimize rates of deterioration. The use of added enzymes when mashing adjuncts has been considered and in the cases of barley- and grits-mashing there is a need for enzymes to cause starch liquefaction and saccharification, β -glucan degradation and protein hydrolysis. The raw barley contains bound and soluble β -amylase, the bound form of which may, at least experimentally, be partly activated and solubilized by additions of the amino acid cysteine hydrochloride, or other thiol-containing substances or sulphite, making this enzyme more useful in mashing. Raw barley contains proteins which can inhibit some microbial proteases. The difficulty in obtaining sufficient assimilable nitrogen from barley- and grits-mashes underlines the absence of inexpensive peptidase preparations suitable for use in mashing.

Enzymes may be added to mashes to speed starch conversion, to degrade β -glucans, or to accelerate wort run-off. Various enzymes are adequately active at mash pHs but these often do not coincide with the pH optima of the enzymes. Usually the mash pH is adjusted only once at the onset of mashing. The exception is when grits are being cooked the pH is adjusted to 6 to allow a heat-stable bacterial α -amylase to act. Afterwards the pH must be

Table 4.7 A comparison of worts made in a Bavarian brewery, with an undermodified, 1931 malt (u) and a well-modified, 1932 malt (m) using four different mashing programmes (data of Lüers *et al.*, 1934). Pi, inorganic phosphate as % of the total in the malt. TSN, total soluble nitrogen, and amino-nitrogen as % of dry extract. In all heating periods, including decoctions, there were rests at 50 °C (122 °F), and 65–68 °C (149–154.4 °F). Worts were collected at 76 °C (168.8 °F)

(% dm)	Extract (% dm)		Wort attenuation (%)		Wort viscosity (relative)		TSN (% dry extr.)		Amino-N (% dry extr.)		Pi (%, total)	Sludge (kg dry)		
	u	m	u	m	u	m	u	m	u	m	m	u	m	
Malt modification														
Two-mash process. Mash in at 50 °C (122 °F). Decoctions to 67 °C (152.5 °F) and then 76 °C (169 °F)	77.5	78.8	66.2	65.6	1.79	1.80	0.87	0.85	0.29	0.26	83.5	11.5	13.6	
Three-mash process. Mash in at 35.5 °C (96 °F). Decoctions to 50 °C (122 °F), 65 °C (149 °F) and 76 °C (169 °F).	78.3	79.3	63.4	64.5	1.71	1.79	0.93	0.89	0.31	0.29	86.4	13.6	9.9	
'High-quick mash process'. Mash in at 68 °C (154.5 °F), then raise to 76 °C (169 °F).	76.2	78.4	67.4	67.5	1.76	1.79	0.92	0.78	0.25	0.21	79.4	26.7	17.5	
Temperature-programmed, infusion-mash. Mashed in at 35 °C (95 °F). Heat with steam-coils, with rests at 50 °C (122 °F), 67 °C (152.5 °F) and 76 °C (169 °F).	78.2	78.8	66.8	66.5	1.68	1.70	0.94	0.86	0.28	0.27	86.4	26.9	22.8	

readjusted downwards to about 5.5 before adding to the malt mash or saccharifying with a fungal saccharogenic amylase or β -amylase, with or without pullulanase. The low temperature stabilities of these enzymes is inconvenient and may necessitate cooling the mash to about 50–55 °C (122–131 °F) to allow them to act to an adequate extent. The choice of which bacterial α -amylase to use is largely dictated by their stabilities. The *Bacillus subtilis* enzyme works well at 70 °C (158 °F) and the more stable enzyme from the *B. subtilis* var. *amyloliquefaciens*, is useful in cookers. It is inactivated on boiling, and this is an advantage. If a more stable enzyme, from *B. licheniformis*, is used it must be under conditions that ensure its inactivation during the copper boil or the composition of the wort and beer will drift with time as degradation of the residual dextrins continues. The addition of uneconomically large amounts of a mixture of bacterial α -amylase and β -glucanase (specific for mixed-link β -glucans) can increase the laboratory extract of a sound malt obtained with an extended mashing schedule, e.g., from 308 to about 313 l°/kg (Albini *et al.*, 1987). The major use of these preparations is to offset the deficiencies of under-modified malts and the presence of barley adjuncts. Most preparations also contain proteases which, while they can usefully increase the level of soluble nitrogen in the wort, can reduce the head formation and stability in the final beer.

In modern breweries with very short ‘turn-round times’ it is essential that wort separation occurs rapidly. Slow wort separation may be associated with using poor or inhomogeneous malt. Of the various enzymes tested the preparations of the relatively heat-stable cellulases, e.g., from *Trichoderma viride* (50–55 °C; 122–131 °F), *Penicillium funiculosum* (65 °C; 149 °F) and *P. emersonii* (80 °C; 176 °F) seem to be successful in accelerating wort separation. These preparations contain complex mixtures of enzymes that attack mixed-link glucans and holocellulose (polysaccharides insoluble in hot sodium hydroxide solution) and may also have pentosanase activity. These preparations sometimes improve extract recovery. In mashes containing a wheat adjunct it may be necessary to supplement the mash with a mixture of cellulase and pentosanase preparations to achieve a sufficiently fast wort separation.

4.3.6 Mashing liquor and mash pH

Mashing liquor must be free of taints, and must be potable. In addition it must be free of many substances and organisms which might reduce beer quality. The quality of the water received must be checked regularly, whatever the source and, if necessary, it must be treated to convert it to the proper quality for the beers to be brewed. For mashing and beer dilution liquors oxygen may have been removed and dilution liquors may have been charged with carbon dioxide, with or without nitrogen (Chapter 3). The ratio of temporary to permanent hardness, the total amount of hardness and the amounts of ions that may influence flavour must be regulated (Narziss, 1992a; MacWilliam, 1975; Taylor, 1981). Interactions between calcium (and to a lesser extent magnesium) ions and wort components have an important effect on mash and wort pH values. Thus bicarbonate ions effectively remove hydrogen ions and so, indirectly, raise the pH:

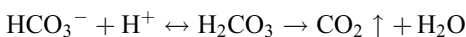

Calcium ions (and magnesium ions to a lesser extent) interact with mash components such as inorganic phosphate, phytic acid and less phosphorylated inositol phosphates, peptides, proteins and probably with other substances displacing hydrogen ions into the mash and reducing the pH. For example,

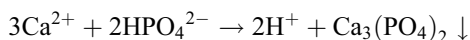

The calcium phosphate tends to precipitate and precipitates more rapidly from wort at higher temperatures. Thus the pH of mashes decline faster during decoction mashing and later the pH of the wort declines further during the hop-boil. Of the calcium ions added to a mash 40–60% are retained in the spent grains.

A major difficulty follows from the habit of measuring the pH of worts or mashes at room temperature and assuming that these values apply at higher temperatures, when they do not (Hopkins and Krause, 1947). Weak acids, like water (see Appendix), dissociate more as the temperature rises and so the pH values of their solutions fall, like the pH values of mashes (Table 4.8). Thus at 65 °C (149 °F) the pH of a wort is likely to be about 0.35 pH unit lower than at room temperature and 0.45 lower at 78 °C (172.4 °F). As the temperature of a mash changes (decoctions, temperature programming, sparging) so will the pH. These differences are significant, yet in many reports it is unclear if pH values have been determined at wort- or mash-temperatures or on cooled samples. Probably the latter is most usual. The pH optimum of α -amylase, determined at room temperature, is about pH 5.3, but its optimum estimated from mashing experiments is often reported to be about 5.7. This error is due to the pH having been determined on the mash after it was cooled, when the pH had risen. Because of this difficulty the pH optima of changes occurring in mashes are a little uncertain (Table 4.9).

Mashing pale malt in distilled water usually gives a wort with a pH of about 5.8–6.0, this value being maintained by the buffer substances (including phosphates and proteins)

Table 4.8 Changes in the pH values of two mashes, made with distilled water and moderately carbonated water, measured at the temperatures shown (after Hopkins and Krause, 1947)

Temperature of measurements		pH values of the mashes	
(°C)	(°F)	(Distilled water)	(Carbonated water)
18	64.4	5.84	6.03
35	95	5.70	5.90
52	125.6	5.65	5.80
65	149	5.50	5.70
78	172.4	5.40	5.55

Table 4.9 ‘Optimal’ pH values for ‘normal’ isothermal infusion mashes made with pale malts lasting 1–2 h. at 65.5 °C (150 °F). Data from various sources. As far as possible the temperatures (mash temperature, m, and cooled wort, w), at which the pH values were determined are indicated (see text for a warning)

Characteristic	‘Optimal’ pH
Shortest saccharification (dextrinization) time	5.3 m–5.7 w
Greatest extract obtained	5.2–5.4 m?
Greatest extract from a decoction mash	5.3 m–5.6 m?
The most fermentable wort	5.1–5.3 m?; 5.4–5.6 w?
Mash impossible to filter	< 4.7
α -Amylase most active (+ Ca ²⁺)	5.3 m–5.7 w
β -Amylase most active	5.1–5.3 (4.7?)
Maximum yield of PSN	4.4–4.6 m; 4.9–5.1 w
Maximum yield of formol-N	4.4–4.6 m, 4.9–5.2 w
Maximum protease activity (depends on substrate)	4.3 m; 4.6–5.0 m?
Maximum phytase activity	about 5.2 m
Carboxypeptidase activity maximal	4.8–5.7

from the grist. Infusion mashes are best carried out at pH 5.2–5.4 (mash temperature), and so will give cooled worts with pH values of about 5.5–5.8. It has been recommended that decoction mashes should not give worts with pH values less than 5.5. Lowering the pH too much results in increases in the soluble nitrogenous materials but lengthens the saccharification time and lowers the yield of extract. Lowering the pH to the correct extent, by additions of calcium salts or other means, speeds the rate of starch degradation, enhances the activities of other carbohydrases and the proteolytic mixture of enzymes so that TSN and FAN values are increased and wort colour is reduced. The solubility characteristics of some proteins are altered, the buffering power of the wort is increased and, at later stages of brewing, hop utilization is decreased. Conversely the increase in pH caused by mashing with waters rich in bicarbonate ions is generally undesirable (Table 4.10). The pH values of mashes are conveniently lowered by mashing with ‘permanently hard’ water, either natural or that has been ‘Burtonized’ by additions of calcium sulphate and/or calcium chloride (Tables 4.11, 4.12). Often about 100 mg of calcium is added to each litre of liquor. However, other means may be adopted such as the direct addition of sulphuric, phosphoric or lactic acids (where this is permitted) or by the use of lactic acid malts or acidified worts.

Table 4.10 The effects of water hardness on the pH values of the cold water extracts and cooled worts prepared by decoction mashing (after Hopkins and Krause, 1947)

Nature of water used	pH of CWE or wort
Distilled water; cold water extract (CWE)	6.2–6.3
Wort, water with temporary hardness (about 15 grains CaCO ₃ /gal., 214 mg/litre)	5.89
Wort, distilled water	5.76
Wort, water with permanent hardness (about 4 grains CaSO ₄ /gal., 57 mg/litre)	5.65

Table 4.11 The amounts of salts (shown in the anhydrous forms) added to some British brewing liquors (Comrie, 1967). Larger amounts of calcium salts may be added to offset the presence of bicarbonate ions. The amounts are varied to allow for alterations in mash thickness and to achieve the desired final flavours. (1 grain/imperial gallon (UK) = 14.21 mg/litre)

Salts	Pale ales		Mild ales		Stouts	
	grains/gal	mg/l	grains/gal	mg/l	grains/gal	mg/l
CaSO ₄	15.7–31.5	223–448	5–10	71–142	none	none
CaCl ₂	6.9–13.7	98–195	7–14	99–199	5.5–11	78–156
MgSO ₄	2.5	36	2.5	36	2.5	36
NaCl	2.5–5.0	36–71	5–10	71–142	7–12	99–171

Table 4.12 The effects of calcium ions, added as calcium chloride, on the pH, extract and soluble nitrogen fractions given by mashes made with one malt at 65 °C (149 °F; Taylor, 1981)

AddedCa ²⁺ (mg/litre)	pH	Extract (litre°/kg)	TSN (ppm)	FAN (ppm)
0	5.74	287	904	188
100	5.48	291	973	195
200	5.39	292	983	207
300	5.28	292	1062	220

The pH values were measured at room temperature. TSN and FAN were adjusted to a wort concentration of SG 1040.

Table 4.13 Some of the influences of adding gypsum (calcium sulphate, CaSO₄·2H₂O. This contains 23.28% Ca, by weight) to the liquor when mashing malt (data of Hind, via Briggs *et al.*, 1981)

Gypsum added (mg/litre liquor)	Extract (l ^o /kg)		Unboiled wort		Boiled wort
	(Apparent)	(Corrected for ash content)	Ash (mg/100 ml)	Phosphates as P ₂ O ₅ (mg/100 ml)	Phosphate as P ₂ O ₅ (mg/100 ml)
0	296.7	286.4	138	70	68
380	300.5	289.3	148	63	59
760	302.9	290.4	167	56	54
1140	305.7	290.6	197	54	50

Additions of calcium ions to the mash reduce the quantities of phosphates in solution but apparently not to undesirable extents (Table 4.13). In addition to the advantages achieved by favourable pH adjustments the calcium ions stabilize α -amylase during mashing, accelerate wort separation and run-off from the mash, assist in break formation in the hop-boil and the beer clarifies better, yeast flocculation is favoured and calcium oxalate crystals (which can be deposited on the walls of fermenters as 'beer stone') are precipitated and so the potentially toxic oxalic acid (4.151) does not go forward. In the beer the calcium oxalate may give rise to haze or initiate gushing. Where the *Reinheitsgebot* and similar laws operate, the addition of 'chemicals' is not permitted and with some beers (e.g. Pilsen-style lagers) the brewing liquor must be soft. In these cases the adjustment of mash pH values is achieved by the use of biologically prepared lactic acid introduced into the mash either as acid malt or as acidified wort. Acid malts are prepared in various ways (Briggs, 1998), and carry 1–5% (typically 2%) lactic acid and, on being mashed alone, give a wort with a pH in the range 3.8–4.4. The pKa of lactic acid is 3.86 at 25 °C. Usual additions are about 5% of the grist but larger quantities may be used. Some beers derive part of their character from the lactic acid they contain. An alternative is to acidify unhopped first wort by incubating it with thermophilic lactic acid bacteria (*Lactobacillus delbrückii*, *L. amylolyticus*) at 45–47 °C (113–116.6 °F) for 8–71 h (Oliver-Daumen, 1988). Batch, semi-continuous and continuous acidification plants are available, the batch type being the most common. It is possible to calculate the amount of acid needing to be added to achieve a desired reduction in pH.

During lautering (wort collection) buffers are washed out of the mash and there is a tendency for the pH to rise, particularly if bicarbonate is present in the hot (e.g. 75–80 °C; 167–176 °F) sparge liquor. This is highly undesirable as at the higher pH unwanted polyphenols and flavour substances are leached from the goods. This may make it necessary to treat the weaker last runnings with active charcoal (to remove unwanted substances), before they are added back to a subsequent mash or are transferred to the copper to be boiled. It is preferable to make sure that any rise in pH during sparging is minimal by excluding the use of water containing bicarbonates and by ensuring that adequate levels of calcium ions are present.

4.3.7 Mash thickness, extract yield and wort quality

Changes in mash thickness (liquor/grist ratio) have significant effects on mash performance (Hind, 1950; Hopkins and Krause, 1947; Harris and MacWilliam, 1961; Muller, 1989; 1991; Table 4.14). Very concentrated mashes, (liquor/grist < 2:1 ml/g), are difficult to mix and pump, extract recoveries are reduced, starch conversion is slowed

Table 4.14 The influence of mash concentration on worts from mashes made at 60°C (140°F), with a duration of 180 min. (Data of Windisch, Kolbach and Schild, via Hopkins and Krause, 1947)

Concentration of mash (water:malt)	2:1	2.7:1	4.0:1	5.3:1
Extract (% dry malt)	71.7	77.0	80.0	79.9
Fermentable extract (% dry malt)	52.3	56.3	58.5	57.8
Fermentable extract (% total extract)	72.9	73.1	73.1	72.3
Permanently soluble nitrogen (% dry malt)	0.57	0.56	0.54	0.53
Formol nitrogen (% dry malt)	0.22	0.21	0.20	0.19

down, worts are more concentrated and viscous, TSN and FAN are increased and more high molecular weight nitrogenous substances remain in solution, but a lower proportion of hydrophobic peptides (relative to the amount of extract) are present, causing 'high gravity' beers to have poor head retentions (Bryce *et al.*, 1997). In the concentrated mashes both the enzymes and their substrates are more concentrated. Some enzymes (proteolytic enzymes, disaccharidases) are more stable in concentrated mashes producing higher proportions of TSN and hexose sugars respectively. At high mashing temperatures thicker mashes give worts with higher fermentabilities (Muller, 1991; Fig. 4.13). On the

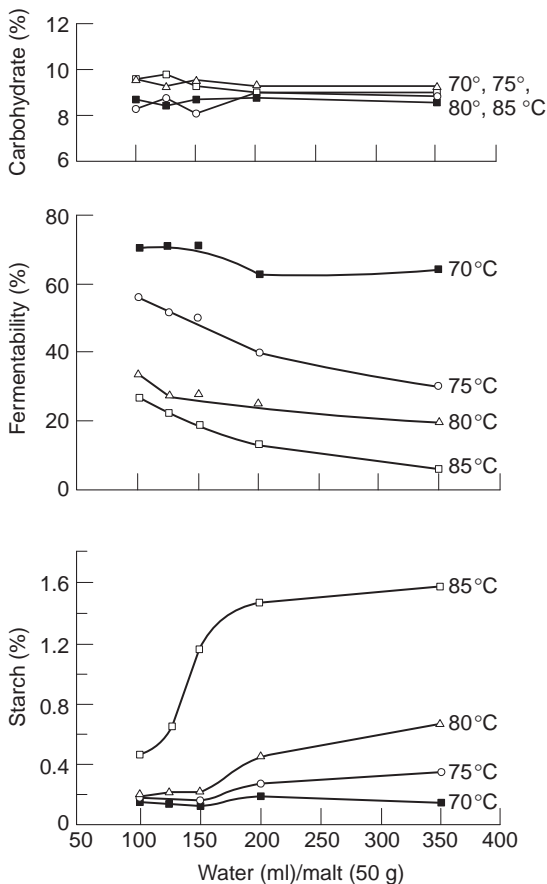

Fig. 4.13 The influences of mash thickness and mash temperature, during 1 h. isothermal mashing, on (upper) the yield of carbohydrate in the wort, (middle) the fermentability of the wort and (lower) the starch present in the wort (after Muller, 1991).

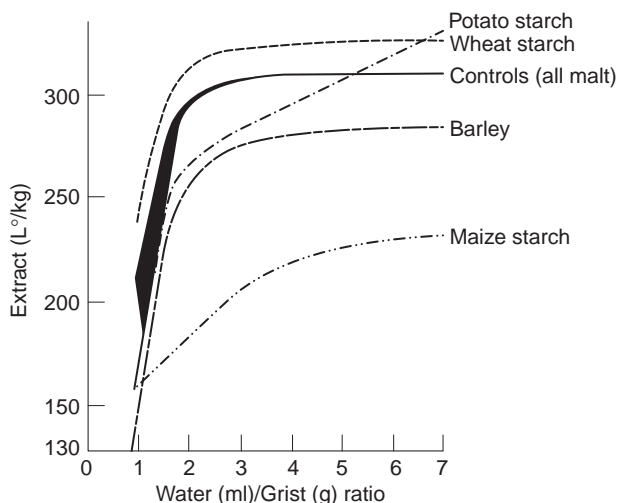

Fig. 4.14 The effects of mash thickness on the extract recoveries from mashes made with all-malt or 50:50 mixtures of malt and the adjuncts indicated (data of Muller, 1991).

other hand, at 'normal' mashing temperatures weaker mashes give more fermentable worts. The high concentrations of sugars and dextrins present in thick mashes can inhibit the amylases. Enzyme inhibition is due to the reduced availability of free water as well as to the sugars acting as competitive inhibitors. Brewery worts contain 0–40% more soluble nitrogen than laboratory analytical worts. It was reported that mashes made with 39% solids give worts with maximum extract yields while worts with the highest fermentabilities are given by mashes made with 16–32% solids. The effects of mash concentration on extract yield are also present when adjuncts are included in the mash (Harris and MacWilliam, 1961; Muller, 1991; Fig. 4.14).

As the grist hydrates water is bound, and there is a rise in temperature caused by the release of heat (the 'heat of hydration'). As the mash proceeds water is utilized in hydrolyses, a water molecule being consumed when any bond is split. Some water is more or less firmly bound (by hydrogen bonding) to starch, to sugars in solution, to β -glucans, to pentosans and to other substances reducing the concentration of 'free' water. In all-malt mashes and mashes made with 50:50 malt and barley or wheat starch the extract recovered falls very sharply as the liquor/grist ratio is reduced below about 2.5 (Fig. 4.14). Generally, altering the liquor/grist ratio at values over 3 has comparatively minor effects, but these are not necessarily negligible. In a particular case mashing with a liquor/grist ratio of 2.5:1 gave an extract of 291 l/kg, while at a ratio of 7:1 the extract was 311 l/kg. The extent of water binding becomes progressively greater as mashes become more concentrated and there is insufficient free water to permit the gelatinization of much of the starch. The addition of more enzymes to a very thick mash does not quickly convert the ungelatinized starch and so does not enhance the extract obtained. The situation with the maize starch (Fig. 4.14) is complicated because its gelatinization temperature (70–75 °C; 158–167 °F) is above that of the mashing temperature (65 °C; 149 °F) and so the conversion of the starch into extract is relatively slow. The potato starch had a wide gelatinization temperature range (56–69 °C; 132.8–156.2 °F), which spanned the temperature of the mash, and the pattern of extract recovery was different again (Fig. 4.14).

4.3.8 Wort separation and sparging

At the end of the mash the wort is separated from the residual solids. This may be a rapid process, as in mash filters, or it may take 1.5–2.5 h in some lauter tuns or 4–18 h in mash tuns. An extended run-off period allows residual enzymes to continue acting for at least part of the time. When a mash tun or lauter tun is used, the first wort to emerge is diluted with the water that was originally under the plates. The first runnings are generally returned to the top of the mash and the wort is recycled until it is completely clear and ‘runs bright’. Then wort collection begins, the strong wort emerges and gradually the mash settles onto the plates. Sparging is started and the liquor, sprayed onto the surface from rotating sparge-arms, permeates down through the goods, progressively leaching out and carrying away the remaining extract. In mash tuns this raises the temperature, so the temperature of the final wort is about 74 °C (165 °F). In contrast, in two- and three-vessel mashing systems the temperature of the whole mash is usually raised to the sparging temperature and after wort recirculation (if this is used), the first wort is collected and the sparge liquor is applied at the same temperature (e.g. 75–78 °C; 167–172.4 °F).

Although sparging temperatures of up to 80 °C (176 °F) may be used, and the use of even higher temperatures has been proposed, these are usually avoided because undesirable flavours and unwanted substances, such as undegraded starch and hemicelluloses, may be eluted from the goods. This is particularly likely if under-modified malt or raw cereal adjuncts have been used. At these elevated temperatures enzyme destruction is rapid, the rates of diffusion of extract materials from the grist particles is rapid, the rate of wort separation (‘filtration’) occurs faster, more protein aggregation occurs and wort viscosity is reduced.

As run off progresses the quality and concentration of the wort declines. The last runnings contain extract that has a comparatively poor quality (Hind, 1950; Figs 4.15, 4.16). Relative to the extract more high- and low-molecular weight nitrogenous materials, ash (including phosphates), silicates (mostly from the silica in the malt husk), polyphenols and astringent substances are dissolved, all these being favoured by the increasing pH. The specific gravity of the wort rises then declines as the sparge liquor emerges. As the wort is diluted the fermentability initially increases and finally falls sharply. Often the pH rises, (e.g. by 0.2–0.7), as the buffering substances are eluted from the goods. The rise is particularly marked if a bicarbonate sparge liquor is used. This rise is undesirable and should be checked and the calcium ion concentration of the liquor should be maintained (Laing and Taylor, 1984). Experimental thick mashes (liquor/grist 2.5/1, i.e. 28.6%) would not run off unless a high concentration of calcium ions (200 mg/l) was used. Thus the last worts are weak, and are relatively rich in poorly flavoured extractives and potential haze-forming substances. These last runnings, like the press liquor from the spent grains (Chapter 3), may be stored hot for a short period (to prevent spoilage by micro-organisms) and then be added to a subsequent mash to recover the extract. However, to maintain the quality of the beer the weak wort may need to be clarified by centrifugation to remove suspended solids (particularly lipids) and/or may be treated with active charcoal (doses of 10–50 g/hl have been suggested) to reduce the levels of tannins, nitrogenous substances, colour and harsh flavours before it is added to a later mash (Morrave, 1938; Precht, 1967).

The faster the wort is run off the higher its content of suspended solids, lipids (which favour flavour instability, i.e. beer staling), and α - and β -glucans which may give problems when the beer is filtered (Muts and Pesman, 1986; Whietar *et al.*, 1983). The lipid contents of strong worts, separated in various devices, were in increasing order mash tun < lauter tun < Strainmaster < older pattern mash-filter, and were given as 10 < 50

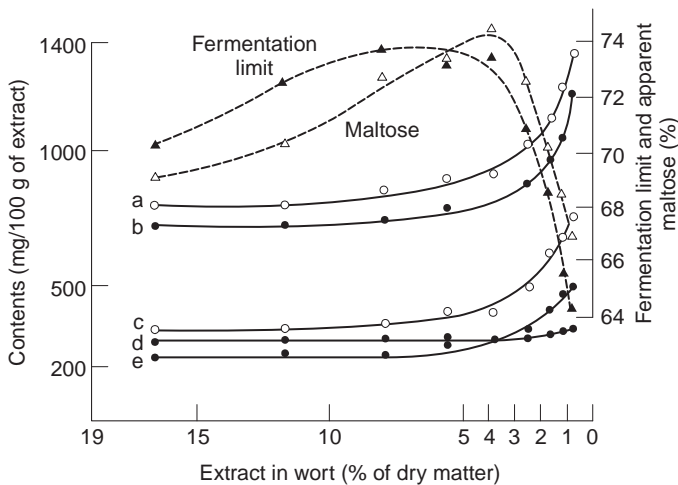

Fig. 4.15 Changes in the composition of sweet wort during run-off and sparging (after Schild, 1936). \blacktriangle --- \blacktriangle fermentation limit; \triangle --- \triangle apparent maltose; (a) total soluble nitrogen; (b) permanently soluble nitrogen; (c) soluble nitrogen not precipitated by phosphotungstic acid; (d) formol nitrogen; (e) nitrogen not precipitated by tannic acid (see also Fig. 4.16).

< 150 < 400 (mg/l). Turbid worts should be clarified as soon as possible in the production process and certainly before they reach the fermentation vessels (Maule, 1986). Recirculation, less usually centrifugation, vigorous boiling and careful solids separation in the whirlpool may be used. Generally bright worts are desirable and care is taken to operate equipment in ways that minimize the release of fine particles. For example raking in the lauter tun is minimized. The Strainmaster lauter unit requires substantial volumes of water to dislodge the spent grains, so it is particularly important to recover the extract in this liquid and to reduce the moisture content of the spent goods (Chapter 3). Poor quality malts may give set mashes (wort separation becomes difficult or

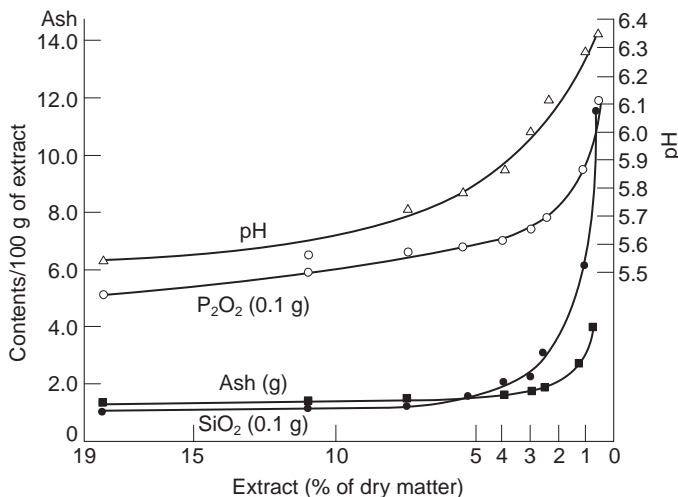

Fig. 4.16 Alterations in wort pH, phosphate content (as P_2O_5), ash content and silica content during wort separation and sparging (after Schild, 1936; see also Fig. 4.15).

impossible without extra manipulations, such as under-letting) in any equipment except mash filters.

Rates of wort separation are faster with more coarsely ground grists but with these extract recoveries are less good than from finely ground grists (Section 6.9). The more a mash is stirred the more fines are produced, the more oxidations are likely to occur (including the cross-linking of gel-proteins), but if stirring is inadequate temperature gradients may occur and mash may settle and burn onto the containing vessel's heating surfaces, so there is a critical, 'compromise' stirring speed (Laing and Taylor, 1984). The deeper the mash-bed the slower wort or sparge liquor will flow through it. Progressively shallower beds and more finely ground grists are used in mash tuns, in lauter tuns and in mash filters. Run-off is impeded by fine particles in the grist (from the malt, cereal flours or formed in the mash) and it is favoured by keeping the malt husk as intact as possible to give the mash bed a more 'open' structure. Mashing under nitrogen gas, experimentally adding bisulphite (which is a reducing agent), adding heat-stable cellulase, maintaining adequate levels of calcium ions (particularly in thick mashes), using well-modified malt, experimentally adding cationic poly-electrolyte flocculants (such as boiled or unboiled lysozyme or partly de-acetylated chitin) and collecting wort at elevated temperatures all favour rapid wort run-off. Malt may contain endogenous flocculants and others may be present from the fungi present on the surface of the grains (Anderson, 1993). In contrast, mashing under air or oxygen gas, experimentally adding the oxidizing agent potassium bromate, omitting calcium ions and using poorly modified malt, all favour slow wort run-off (Anderson, 1993; Barrett *et al.*, 1973, 1975; Crabb and Bathgate, 1973; Laing and Taylor, 1984; Muller, 1995; Muts *et al.*, 1984).

Poorly modified malts are rich in non-starch polysaccharides (NSPs; pentosans and β -glucans) and undegraded proteins which are rich in thiol groups. The oxidation of cysteine side chains produces disulphide links between protein chains that can produce an insoluble, jelly-like mass of 'gel-protein'. Reduction of this material should disperse the protein gel. An inverse correlation has been established between the gel-protein content of malt and wort separation rate. The hemicellulosic polysaccharides may also form a gel, which can be attacked by β -glucanases, and so improve wort separation (Crabb and Bathgate, 1973). Fine aggregates of protein, small starch granules, cell-wall non-starchy polysaccharides (NSPs) and lipids can form 'high flow-resistant' layers in a mash and particularly in the poorly permeable gel-like layer (the *Oberteig*) which forms on the surface of mashes in lauter tuns. Removal of this layer reduces the pressure differential across the bed, increases the flow-rate of the wort but reduces extract recovery (Muts and Pesman, 1986). The composition of this layer is variable; two examples contained, respectively, 18 and 20% protein and 65 and 79% polysaccharides. The composition of the small aggregates which form in mashing is also variable; for example, small starch granules, 4–21%, β -glucan, 3–19%, pentosan, 5–31% and protein 26–42%. In the case of particles from an all-malt mash, which contained 29% starch, the free lipid content was 5% and the bound lipid was 17% (Barrett *et al.*, 1975). The bound lipid may have been associated with the starch.

These particles probably contribute to, or constitute, the *Oberteig*. The formation of this material is favoured by oxidizing conditions. Small starch granules are often firmly invested with protein which, when oxidized, presumably firmly binds them into the particles. During mashing the greater part of the malt is dissolved, and some proteins are dissolved and, particularly as the temperature rises in temperature-programmed or decoction mashes, a proportion of the protein is denatured, aggregates and precipitates (Lewis and Oh, 1985; Bühler *et al.*, 1996). The finer particles (< 1–150 μm) tend to block

the pores of the mash and impede run-off, but as the particles aggregate and enlarge so their obstructive effect becomes less. Larger particles are favoured by cationic flocculants and (apparently) adequate concentrations of calcium ions. Aggregation is better at higher temperatures, and so in three mashes that had been not been heated above 65 °C (149 °F) offered 3, 3 or 3.7 times the specific resistance to the flow of the wort offered by mashes that had been heated to 80 °C (176 °F; Bühler *et al.*, 1996).

‘Models’ of liquid flow through mashes, for instance based on Poiseuille’s equation, which relates to flow through parallel capillary tubes, or the Carman-Kozeny equation or Darcy’s law, that relate to beds of spherical particles, all emphasize that the rate of flow through a bed of particles is proportional to a constant, the pressure difference across the bed, the channel radius to the power 4, to the diameter of the particles squared, and inversely proportional to the depth of the bed and to the viscosity of the liquid (Anderson, 1993; Bathgate, 1974; Huite and Westermann, 1974; Laing and Taylor, 1984; Meddings and Potter, 1971; Webster, 1978).

As the temperature is increased so wort viscosity falls to comparatively low levels and the small particles aggregate and increase in size. Both changes favour faster wort separation. While the viscosity of wort (caused mainly by dissolved sugars and, to varying extents, by polysaccharides and perhaps other materials) is not unimportant the major limitation in wort separation for a bed of a given depth is the ‘average’ particle diameter, d . Because the flow rate is proportional to d^2 , as d becomes smaller so the flow rate rapidly declines ($d = 1$, flow = 1; $d = 0.5$, flow = 0.25; $d = 0.1$, flow = 0.01, etc.). Determining an ‘average’ diameter, d is impracticable for the particles in a mash, and in any case it is not the depth of the entire mash but the characteristics and depth of the surface *Oberteig* layer that are often limiting. By using a derived formula that relates to compressible beds it is possible to find bed permeabilities and so test the factors that may influence them (Laing and Taylor, 1984).

4.4 Mashing biochemistry

4.4.1 Wort carbohydrates

The complex mixture of carbohydrates in wort makes up about 92% of the solids in solution. The most important sugars and dextrans in wort are made of glucose, which also occurs free (4.1). Thus maltose (4.4), maltotriose (4.5) maltotetraose (4.6) and maltopentaose (4.7) are made of D-glucopyranose units joined by α -(1,4) links (Table 4.15). In cellobiose (4.18) and laminaribiose (4.19) the glucose residues are linked by β -(1,4) and β -(1,3) bonds, respectively. (An introduction to carbohydrate chemistry is given by Coultate, 2002). The precise composition of the mixture will depend on the make-up of the grist and the mashing conditions. In some ‘conventional’ sweet worts the carbohydrate spectra are surprisingly similar, whether or not mash tun adjuncts are used (MacWilliam, 1968). The exceptions are when mashing is carried out to produce ‘low-alcohol’ beers or ‘low-carbohydrate’ beers when the conditions are chosen to obtain poorly fermentable and maximally fermentable worts, respectively (Chapter 15). Wort fermentability may be increased by adding amyloglucosidase or, preferably, other microbial enzymes, such as pullulanase and β -amylase or fungal saccharogenic amylase to the mash and/or to the fermenter.

The conversion of barley into malt involves a considerable loss of potential extract (Briggs, 1998; Table 4.16). Sugars fermentable by most yeasts are the monosaccharides glucose (4.1) and fructose (4.2), the disaccharides sucrose (4.3) and maltose (4.4) and the

Table 4.15 The major wort carbohydrate fractions compared with the ‘potentially extractable’ carbohydrates of malt (data of Hall *et al.*, 1956). The brewery extract of the malt was 102.2 lb/Qr (about 77.5%; 303.5 l/kg). The laboratory extract was 104.6 lb/Qr (about 78.9%; 309.1 l/kg). The values are given as hexose equivalents, that is, as if each fraction had been fully hydrolysed to yield its component hexoses, and so the reported weights are greater than the weights of the unhydrolysed materials. The carbohydrates made up 91.8% of the wort solids

Malt carbohydrates (hexose equivalents as % total wort solids)		Wort carbohydrates (hexose equivalents as % wort solids)	
Starch	85.8	Dextrins, glucans and pentosans	22.2
Glucans and pentosans*	2.5		?
Fructans [†]	1.4		?
–	–	Maltotetraose	6.1
Maltotriose	0.6	Maltotriose	14.0
Maltose	1.0	Maltose	41.1
Sucrose	5.1	Sucrose	5.5
Glucose	1.7	Glucose + Fructose	8.9
Fructose	0.7		
Total	98.8		97.8

* These ‘gums’ were soluble in water at 40°C (104°F). The maltose fraction in the wort contained a trace of unfermentable isomaltose. [†] Fructans in the wort were included in the other fractions but were certainly present. Maltotetraose was essentially absent from the malt.

trisaccharide maltotriose (4.5). Typically maltose is the most abundant sugar in wort. Sugars in a 12% wort, in g/100 ml, were glucose + fructose, 0.9–1.2; sucrose, 0.4–0.5; maltose, 5.6–5.9; and maltotriose, 1.4–1.7; total 8.3–9.3 (Evans *et al.*, 2002). Some yeasts only attack maltotriose (4.5) to a limited extent, while other ‘super-attenuating’ strains may also utilize maltotetraose (4.6) and dextrins. The monosaccharides are

Table 4.16 The carbohydrate composition (% dry basis) of Carlsberg barley (TN 1.43%) and a floor-malt made from it (recalculated from Hall *et al.*, 1956). The supposed ‘structural carbohydrates’ that are not involved with extract formation have been ignored

	Barley	Malt
Glucose	0.04	1.31
Fructose	0.07	0.55
Sucrose	0.77	3.73
Maltose	0	0.73
Maltotriose	0	0.42
‘Glucodifuctose’	0.08	0
Raffinose	0.15	0
Fructans	0.58	1.00
Glucans and pentosans*	2.10	2.45
Starch	65.86	58.90
Total	69.65	69.09

* Non-starch polysaccharides soluble in warm water at 40°C (104°F). The raffinose went during germination, but the ‘glucodifuctose’ could not be determined in the malt, and will have been included in another fraction.

The thousand corn dry weights of the barley and the malt were 39.1 g and 35.3 g respectively, so the malt yield was $35.3 \times 100/39.1 = 90.3\%$.

100 g barley contained 65.86 g starch hexose, while 90.3 g malt (from 100 g barley) contained 58.90×0.903 g starch hexose = 53.19 g. Thus the recovery of barley starch in the malt was $53.19 \div 65.68 \times 100 = 80.8\%$. Thus the starch going during germination was 19.2%.

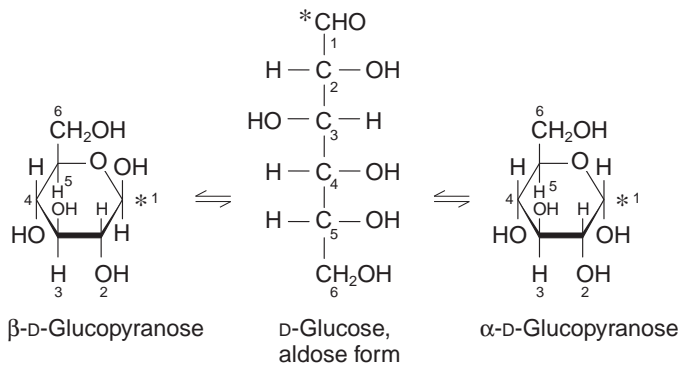

(4.1)

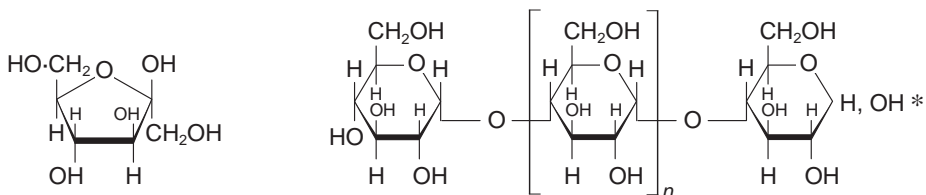

(4.2)

Maltotriose ($n = 1$); maltotetraose ($n = 2$); maltopentaose ($n = 3$)

(4.5)

(4.6)

(4.7)

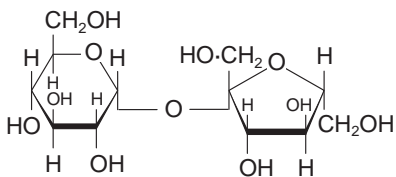

Sucrose; α -D-glucopyranosyl-(1 \rightarrow 2)- β -D-fructofuranoside

(4.3)

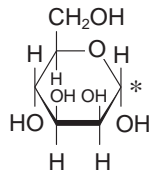

Mannose; α -D-mannopyranose

(4.8)

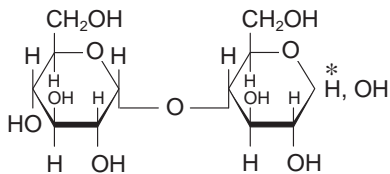

Maltose; α -D-glucopyranosyl-(1 \rightarrow 4)-D-glucopyranose

(4.4)

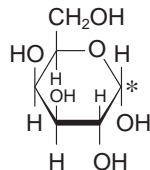

Galactose; α -D-galactopyranose

(4.9)

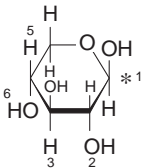

Xylose; β -D-xylopyranose

(4.10)

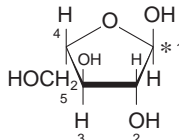

Arabinose; α -L-arabinofuranose

(4.11)

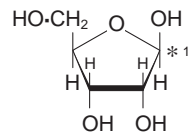

Ribose; β -D-ribofuranose

(4.12)

fermented the most rapidly, while maltotriose is fermented slowly and sometimes incompletely so traces may remain in beer. Dextrins, derived from the partial degradation of starch, are not fermentable and neither are pentosans nor are β -glucans. Sometimes the ‘fermentable sugars’ and ‘dextrins’ groups are determined and the results are used to calculate the carbohydrate fermentability of the wort as the fermentable carbohydrates as a percentage of the total carbohydrates. Values in the range 64–77% are common. The fermentable carbohydrates are the major energy source of the yeast and alcohol and carbon dioxide are the major metabolic products. The major source of extract in an all-malt wort is starch, but preformed sugars are also important and of these sucrose (4.3) is the most abundant (Tables 4.15, 4.16). Mannose (4.8) and galactose (4.9) occur combined in malt but neither is released during mashing. In worts maltose (4.4), along with many other substances, is produced during mashing by the partial hydrolysis of starch.

Table 4.15, which quantifies the major groups of carbohydrates, indicates the major sources of the carbohydrates in the extract. However, depending on the grist, isothermal mashes may yield about 2% of extract from non-starch polysaccharides while this value may reach 6% in decoction mashes. The value is likely to be higher when the mashes are supplemented with microbial enzymes, which attack non-starch polysaccharides. The levels of the monosaccharides in wort should not be abnormally high (as can be the case when amyloglucosidase is added to the mash) because this can interfere with the uptake and metabolism of maltose (4.4) and maltotriose (4.5) by yeast, causing a ‘sticking fermentation’ (the premature cessation of the fermentation). While the major simple sugars are as indicated other sugars occur in minor amounts. Pentoses are present (e.g. xylose (4.10) at 1.5 mg/100 ml, arabinose (4.11) at 1.4 mg/100 ml and ribose (4.12) at 0.2 mg/100 ml) compared to maltose (4.4) at 4000 to 6000 mg/100 ml.

The pentoses are more abundant in decoction and (probably) temperature-programmed worts than in simple infusion worts, since the conditions in infusion mashes do not favour the enzyme-catalysed breakdown of pentosans. Other sugars detected in tiny amounts are isomaltose (4.13), panose (4.14), isopanose (4.15), nigerose (4.16) and maltulose (4.17). Apparently cellobiose (4.18) and laminaribiose (4.19), expected breakdown products of β -glucans, have not been detected. β -Glucans and pentosans are always present, but in varying amounts. Carbohydrates also occur in glycolipids, in nucleic acids and nucleotides as well as glycoproteins. These are important in various ways, but are insignificant in terms of extract yield. The calorific value of beer is due to the unfermentable carbohydrates and the ethanol (ethyl alcohol). Small amounts of fructans occur in malt. These can be regarded as sucrose molecules (4.3) to which one or more fructose residues have been attached. Simple examples are kestose (4.20), isokestose (4.21) and bifurcose (4.22). The fate of fructans in mashing is not known.

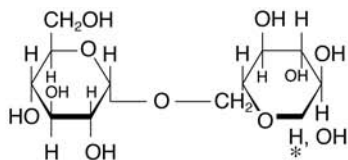

iso-Maltose; α -D-glucopyranosyl-(1 \rightarrow 6)-D-glucopyranose

(4.13)

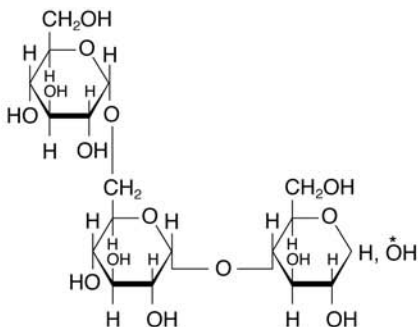

Panose (4- α -isomaltosyl-D-glucose)

(4.14)

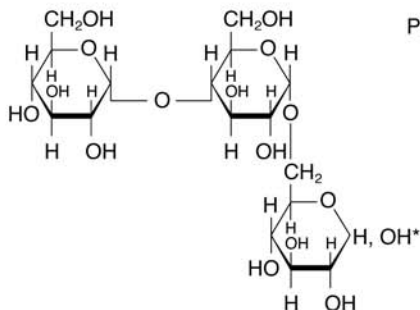

Isopanose, O- α -D-glucopyranosyl-(1 \rightarrow 4)-O- α -D-glucopyranosyl-(1 \rightarrow 6)-D-glucopyranose

(4.15)

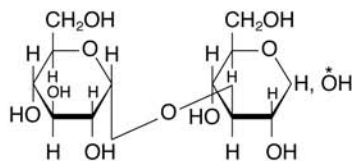

Nigerose, α -D-glucopyranosyl-1,3-D-glucopyranose

(4.16)

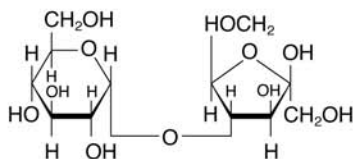

Maltulose (4-O- α -D-glucopyranosyl-D-fructose)

(4.17)

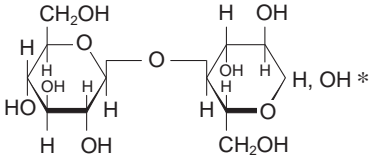

Cellobiose; β -D-glucopyranosyl-(1 \rightarrow 4)-D-glucopyranose

(4.18)

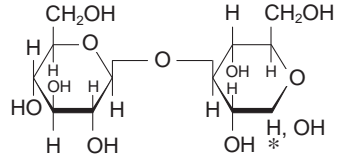

Laminaribiose; β -D-glucopyranosyl-(1 \rightarrow 3)-D-fructofuranose

(4.19)

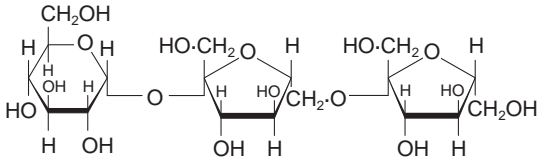

Kestose (6-kestose); α -D-glucopyranosyl-(1 \rightarrow 2)- β -D-fructofuranosyl-(6 \rightarrow 2)- β -D-fructofuranoside

(4.20)

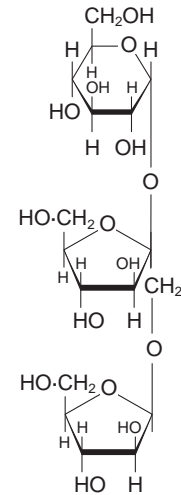

iso-Kestose (1-kestose); α -D-glucopyranosyl-(1 \rightarrow 2)- β -D-fructofuranosyl-(1 \rightarrow 2)- β -D-fructofuranoside

(4.21)

4.4.2 Starch degradation in mashing

Starch makes up the greatest proportion of malt, often about 58% (dry basis), and is present in greater proportions in some mash tun adjuncts. The breakdown products of starch make up most of the extract in worts. In malt the starch is practically confined to the starchy endosperm where, in the undermodified regions, it is enclosed in the cell walls. It is often invested with protein, which may impede its breakdown. Starch is

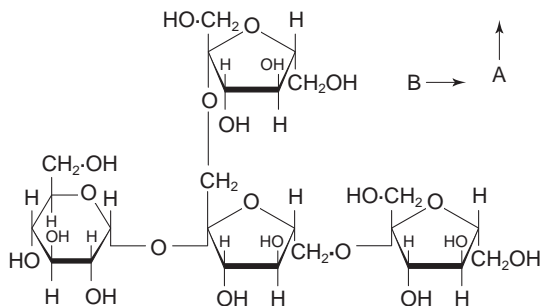

Bifurcose, the basic unit of the two series of fructosans. Extended in direction A, with β (2 \rightarrow 1)-linked fructofuranose units; kriesin (inulin-type) fructosans. Extended in direction B with β (2 \rightarrow 6)-linked fructofuranose units: hordeacin (phlein type)

(4.22)

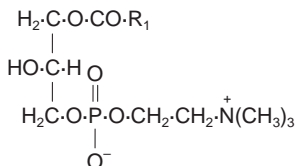

Lysophosphatidylcholine

$\text{R}_1\cdot\text{CO}-$ is a fatty acid residue

(4.23)

deposited in organelles called amyloplasts, and presumably residues of these also surround it. It occurs as granules. In barley the granules occur in two populations, the larger A granules that may have diameters of 22–48 μm , and B granules with diameters of 1.7–2.5 μm . The large granules make up 10–20% of the granules by number but 85–90% by weight. The large granules have a lower gelatinization temperature range than the small granules.

As the sugar concentration of the surrounding liquid increases, so the gelatinization temperatures of starches increase (Bathgate and Palmer, 1972; Briggs, 1978, 1992, 1998; Eliasson and Tatham, 2001; Letters, 1995a, b; Stone, 1996; Tester, 1997). Starches from other sources may differ significantly, both in size, shape and physical properties (Chapter 2). The major components of the granules are the polysaccharides amylose and amylopectin, together called 'starch'. However, the granules are not pure starch, but also contain some protein, ash and lipids. Typically amylose makes up 22–26% of the polysaccharide, the balance being amylopectin. Amylose is a mixture of predominantly linear α -(1,4)-linked chains of D-glucopyranose, about 1600–1900 residues long (Fig. 4.17). The presence of occasional branch-points, formed by α -(1,6)-links, is indicated by the incomplete hydrolysis of amylose by β -amylase. In solution amylose can retrograde, that is crystallize and separate from solution. This retrograded material is comparatively resistant to enzymic attack, and so will not readily be converted into extract if formed during mashing. Amylose adopts a helical shape (six glucose residues/turn) and inclusion compounds can be formed with polar lipids or iodine being contained in the helix. The complex with iodine has a characteristic blue-black colour. The lipid inclusion

complexes, which occur in barley starch, involve mainly lysophosphatidyl choline, LPC (4.23), and are not readily degraded by enzymes. The polar choline moiety projects from the end of the helix. The presence of lipids slows, or prevents, retrogradation. Other cereal starches contain inclusion compounds with free fatty acids. The lipid complexes do not give colours with iodine and so incompletely degraded starch that is complexed is not detected by the iodine test unless the lipid is first removed, for example, with butanol. Thus the iodine test, as usually applied to samples from the mash or to spent grains, is unreliable and does not detect all undegraded starch. Each amylose molecule (molecular weight $26-31 \times 10^4$) will have a non-reducing chain end, in which the terminal glucose residue is unsubstituted on position C-4, (4.1) and a reducing chain end where the terminal glucose has a free C-1 position.

Amylopectin is a mixture of highly branched molecules, the α -(1,4)-linked chains, around 26 glucose units long on average, are joined through α -(1,6) branch-points, which may number c. 6% of the bonds in the molecules (Fig. 4.17). Molecular weights may be very high, e.g., $2 \times 10^6-4 \times 10^8$. Amylopectin is less soluble in water than amylose. The chains may also adopt helical configurations which, with iodine, give a red-violet colour. Each amylopectin molecule has only one reducing chain end but numerous non-reducing chain ends (Fig. 4.17). The polysaccharide molecules are ordered in the starch granules, which have a partly crystalline structure, as shown by X-ray diffraction. In the granules the crystalline regions alternate with the amorphous regions, which are more easily attacked by enzymes. The amylose molecules are supposed to be mixed in among the amylopectin, but the arrangements proposed are tentative (Fig. 4.18; Imberty *et al.*, 1991). The ordered molecular structure of the granules is also demonstrated by their birefringence. In polarized light the granules appear to have a dark 'maltese cross' on a light background. As the starch is heated in water and gelatinization begins so the swelling granules begin to lose their birefringence and the crosses disappear, a fact that allows an estimation of the gelatinization temperature range of the starch. Gelatinized starch is readily attacked by enzymes, but this should take place before retrogradation of any of the amylose occurs. The amylose-lipid complexes of some starches are not disrupted in cooking until temperatures of $90-120^\circ\text{C}$ ($194-248^\circ\text{F}$) are reached, which may explain the need to cook some adjuncts at temperatures above the gelatinization temperatures of their starches. On cooling inclusion complexes can slowly reform, and so the enzymic degradation of the 'liberated' amylose should not be delayed.

'Diastase', the mixture of malt enzymes that catalyses the hydrolytic breakdown of starch, has been studied for many years, but even now there are uncertainties about the roles of some of the component enzymes (Fig. 4.19; Briggs, 1992, 1998). Of these enzymes only the activity of β -amylase correlates well with the determination of diastatic power, DP, as it is usually determined. Older studies attributed the conversion of starch during mashing to the activities of the α - and β -amylases. While these are the enzymes chiefly involved it seems that, at least in temperature-programmed mashes, other enzymes play significant roles.

Malt α -amylase is a mixture of different molecules (isoenzymes), having slightly differing properties and these are formed during malting; they are essentially absent from sound, ungerminated barley. The three 'classes' observed each contain multiple forms. α -Amylase-I occurs in comparatively small amounts in malt. It is relatively resistant to acid conditions and chelating agents because it binds calcium ions very strongly. It is inhibited by small amounts of heavy metal ions, such as copper. α -Amylase-II is the 'classical' malt enzyme. It is comparatively resistant to heat, particularly in the presence of excess

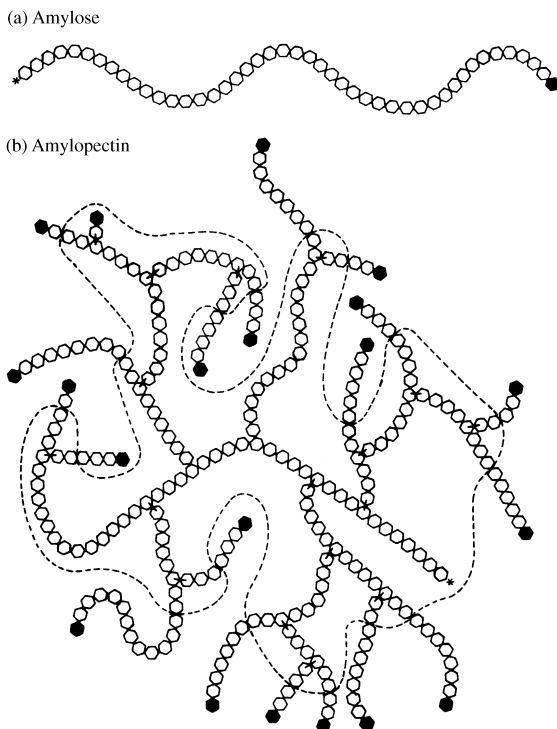

Fig. 4.17 Idealized diagrams of (a) amylose and (b) amylopectin. The chains of D-glucopyranose residues (hexagons) are joined by α -(1,4)-links in the amylose and the short chains of the amylopectin which are joined together through α -(1,6)-links, which create branch points, in the amylopectin. The reducing chain ends are marked with an asterisk, while the non-reducing chain ends are indicated with solid hexagons. While the straight chained amylose molecule has only one reducing group and one non-reducing chain end, the highly branched amylopectin has one reducing group but numerous non-reducing chain ends per molecule. The dashed line around the amylopectin indicates the approximate limit of the β -limit dextrin remaining after the molecule has been attacked by pure β -amylase. The shortened branches, of two or three glucose residues, are readily hydrolysed by limit dextrinase or pullulanase to release maltose or maltotriose. The debranched dextrin can be degraded further by β -amylase.

calcium ions, and to heavy metal ions, but it is inhibited by calcium-binding ‘chelating agents’, such as phytic acid. It is not completely stable in mashes. It has a pH optimum of about 5.3, and it is unstable at values below 4.9. ‘ α -Amylase-III’ is a complex between α -amylase-II and another small protein, BASI, (barley amylase/subtilisin inhibitor), which limits the activity of the enzyme. This complex is probably disrupted at starch conversion temperatures. The α -amylase mixture from malt attacks the α -(1,4)-links within the starch chains, producing a range of products. Attack is slower at the chain-ends and ceases near the α -(1,6) branch points. The products of extensive α -amylolysis include glucose (4.1), maltose (4.4), and a complex mixture of branched and unbranched oligosaccharides and dextrans (Fig. 4.19). Because this kind of attack reduces the starch-iodine colour rapidly, but increases the reducing power of the digest comparatively slowly this enzyme is often referred to as a ‘dextrinogenic’ amylase. It is also able to liquefy starch gels. This enzyme is capable of degrading intact starch granules as is α -glucosidase. In mashing, α -amylase liberates the dextrans that are the substrate for the ‘saccharogenic’ β -amylase.

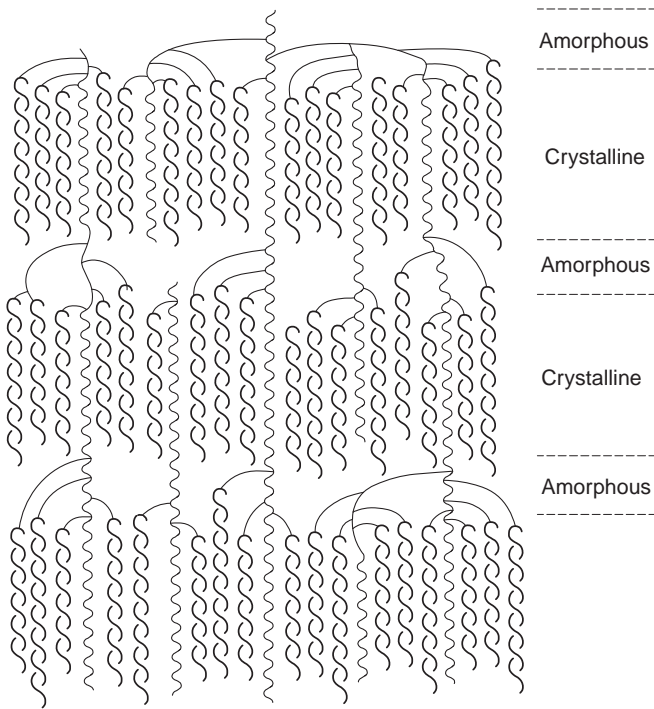
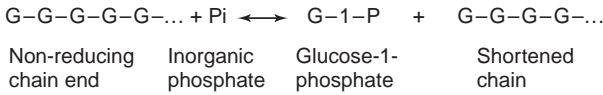

Fig. 4.18 A diagram of the ways in which amylopectin molecules may be packed together in a starch granule to create amorphous and crystalline regions, which differ in their susceptibilities to enzymolysis (after Imberty *et al.*, 1991). Many of the side chains are wound together in double helices. The single reducing chain end is at the top of the diagram. Linear amylose molecules, some of which are in the form of helices and inclusion compounds with polar lipids are, in some way, interspersed with the amylopectin in the granules, possibly in the amorphous regions.

β -Amylase occurs in barley in insoluble and soluble forms, and is of value when raw barley is used as a mash tun adjunct. During malting the proportion of the ‘free’, soluble enzyme increases as does the ease of extraction. Little or no more enzyme is formed during germination. The soluble enzyme contains multiple forms having various molecular weights, including dimers in which enzyme is linked to the, enzymically inactive, protein Z by disulphide bonds and in which high proportions of the monomers seem to be partially proteolytically degraded forms of at least two genetically distinct isozymes. The insoluble enzyme can be partly released by proteases, such as papain, by agents which reduce, and so break, the disulphide bonds between the enzyme and other insoluble proteins, and by ‘amphipathic’ detergents that disrupt hydrophobic bonds (Buttimer and Briggs, 2000). Compared to α -amylase, β -amylase is relatively sensitive to heat and heavy metal ions and is resistant to mild acidity and chelating agents.

β -Amylase from different barleys differs in its temperature sensitivity. Barleys with the more stable enzyme give malts which yield the most fermentable worts (Evans *et al.*, 2002). This enzyme is readily inactivated by chemical agents that react with thiol groups. It has a broad pH optimum around 5.0–5.3, (but which alters with the buffer used in the activity measurements), catalyses the hydrolysis of the penultimate α -(1,4)-link of the non-reducing chain ends of amylose and amylopectin, with the release of the reducing disaccharide maltose (4.4), the most abundant sugar in wort (Fig. 4.19). However, the enzyme will not hydrolyse α -(1,4) bonds near to α -(1,6) branch-points in amylopectin or

Phosphorylase



β-Amylase

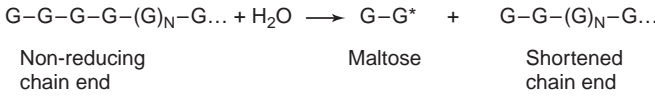

α-Glucosidase

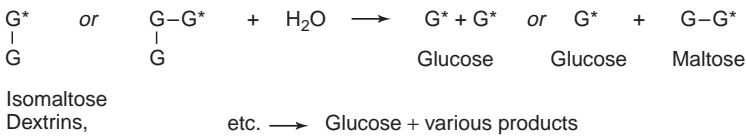
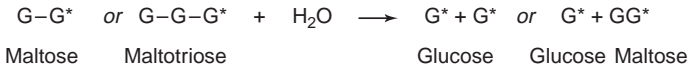

α-Amylase

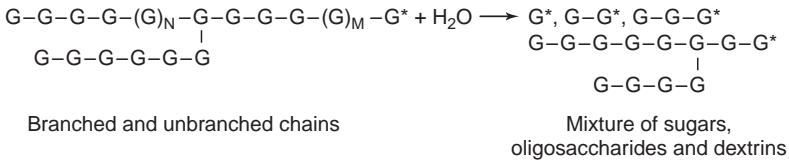

Debranching enzyme (limit dextrinase; R-enzyme)

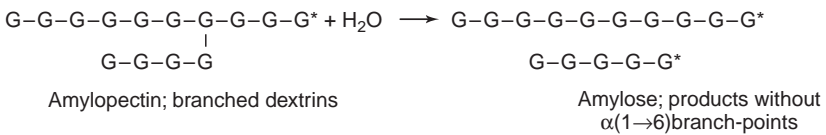

Transglucosylase reactions

(These may be catalysed by various enzymes, as 'side reactions')

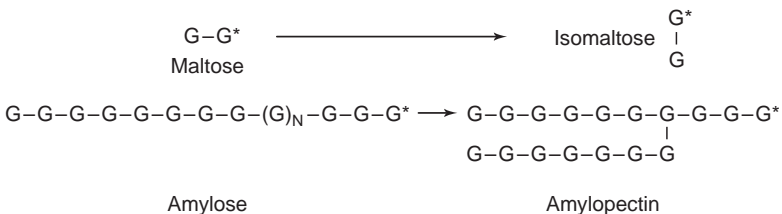

Fig. 4.19 A summary of how the enzymes, that together make up diastase, act on the polysaccharide components of starch or their breakdown products (after Briggs, 1998). G, α-D-glucopyranose residues – , (1,4)-link |; (1,6)-link; *, reducing group.

dextrins. Thus if dispersed starch is attacked by β -amylase acting on its own amylose molecules are broken down, with the liberation of maltose, until one of the occasional branch-points is encountered, while amylopectin is degraded to maltose and a β -limit dextrin in which all the non-reducing chain ends are within two or three glucose residues of branch points (Fig. 4.17). In mashing a few of the α -(1, 6)-links may be broken by limit dextrinase, with the release of maltose (4.4) or maltotriose (4.5), or α -glucosidase, with the release of glucose (4.1), and links within the chains can be broken by α -amylase. In each case the effect is to expose a non-reducing chain end that the β -amylase can attack. The extensive degradation of starch that occurs during mashing depends on the concerted action of the mixture of enzymes present and is often limited by enzyme destruction rather than the absence of substrates for possible enzyme attack.

Phosphorylase, the enzyme that catalyses the cleavage of the terminal α -(1, 4) links in non-reducing chain ends with inorganic phosphate to release glucose-1-phosphate, is present in barley and green malt (Fig. 4.19). Apparently its possible role in mashing has never been investigated. Like β -amylase this enzyme can degrade chains until it comes to a branch point. As wort contains inorganic phosphate this enzyme may be active and as phosphatases are also present the glucose-1-phosphate generated would be hydrolysed to glucose and phosphate, the overall effect being the same as degradation by α -glucosidase.

α -Glucosidase is present in barley and increases in amount during malting (Briggs, 1998). The enzyme seems to have several forms differing in their substrate specificities and a proportion is insoluble but still able to catalyse the hydrolysis of small molecules such as maltose (4.4) (Fig. 4.19). The enzyme has a pH optimum of about 4.6 and a temperature optimum of 40–45 °C (104–113 °F). This enzyme is probably active in the early stages of temperature-programmed mashing. Like α -amylase this enzyme attacks starch granules (Sun and Henson, 1990), and acts synergistically with α -amylase in this respect. This enzyme attacks maltose (4.4), isomaltose (4.13), oligosaccharides, dextrins and starch at the ends of the non-reducing chains, hydrolysing α -(1, 4) links preferentially and α -(1, 6) links more slowly (Fig. 4.19). Like some other carbohydrases this enzyme can catalyse transglucosylation in strong solutions of sugars, generating small amounts of different materials. The data on the role of this enzyme in mashing is inadequate, but indirect evidence suggests that its action can be significant in temperature-programmed mashes.

Debranching enzyme catalyses the hydrolysis of α -(1, 6) links in amylopectin and dextrins. Previously it was thought that two enzymes were involved and these were referred to as limit dextrinase and R-enzyme. When the enzyme acts on β -limit dextrins maltose (4.4) and maltotriose (4.5), but not glucose (4.1), are released. While the role of the malt enzyme in brewer's mashes is uncertain the value of using the similar bacterial enzyme pullulanase in making highly fermentable worts is clear (Enevoldsen, 1975). The survival of this enzyme in malt is strongly dependent on the kilning conditions. The enzyme occurs in insoluble and soluble forms and much of the soluble enzyme is inhibited by one or more associated proteins. It was thought that as most of the α -(1, 6) links initially present in the mash survived into the wort the activity of debranching enzyme must have been insignificant (Enevoldsen, 1975). However, more recent work indicates that in spite of earlier reports the enzyme is at least as stable as β -amylase in mashes and its activity may be significant in some circumstances (Bryce *et al.*, 1995; Sissons, 1996; Sjöholm *et al.*, 1995; Stenholm and Home, 1999; Stenholm *et al.*, 1996). Clearly, brewers or distillers who require highly fermentable worts, desire high levels of active debranching enzyme and low levels of the inhibitory proteins in their mashes.

Experiments with soluble starch and enzyme preparations in buffered solutions are unrealistic 'models' for mashes in that the conditions are significantly different and this

alters the stabilities of the enzymes and indeed takes no account of the insoluble enzymes present in malt. α -Amylase acting alone on starch for an extended period, at various temperatures around 65 °C (149 °F), produces poorly fermentable worts (about 20%) and this result is comparatively temperature insensitive. If the α -amylase is supplemented with increasing amounts of β -amylase (probably contaminated with other enzymes) then wort fermentability increases. However, the higher the temperature the lower the fermentability. Thus, as expected, wort fermentability is dependent on both the mashing temperature and the amounts of enzymes present in the mash. At higher temperatures the heat-labile β -amylase is destroyed faster and so the 'dextrins' produced by the α -amylase are less-well 'saccharified' by the other, more heat labile enzymes. This is consistent with experience with the results of experimental isothermal mashes (Table 4.17; Fig. 4.20). Alterations in isothermal mashing temperatures and durations and malt quality influence extract yield and its quality (Fig. 4.9; Tables 4.6; 4.17). The changes occurring in temperature-programmed mashing are more complex (Stenholm *et al.*, 1996; Gjertsen and Hartlev, 1980; Schur *et al.*, 1973; Table 4.18). Thus, during a mash programmed with rests at 48 °C, 63 °C, 72 °C and 80 °C (118.4, 145.4, 161.6 and 176 °F) extract rose, but at a decreasing rate, until the temperature rise from 63 to 72 °C when it became constant (Fig. 4.21). Fermentability stopped rising during the 63 °C rest, when about 0.7 of the β -amylase initially present had been destroyed. Destruction was completed as the temperature rose to 72 °C. α -Amylase destruction was not complete until 80 °C had been reached.

While the patterns of sugar formation during mashing reflect enzyme activities they do not unambiguously demonstrate which enzymes are active. Thus fructose (4.2) may originate from the hydrolysis of sucrose (4.3) or higher oligosaccharide fructans, or from free sugar initially present in the grist. Glucose (4.1) occurs in malt and during mashing may be formed by the activity of α -amylase, α -glucosidase or β -glucosidase. Maltose is undoubtedly mainly formed by β -amylase but there may be contributions from debranching enzyme (acting as a limit dextrinase) and α -amylase. In temperature-programmed mashes the rise in glucose at low temperatures suggests that α -glucosidase is active (Schur *et al.*, 1973). The patterns of sugars present in isothermal mashes made at different temperatures indicate that glucose production is maximal at about 57 °C (approx. 135 °F), which is consistent with α -glucosidase activity (Taylor, 1974; Fig. 4.20).

When starch-containing adjuncts are added in increasing amounts to mashes, wort fermentability usually declines before extract recovery indicating that saccharogenic activity becomes limiting before dextrinogenic activity, essentially α -amylase. However, increasing the amount of α -amylase in these mashes can increase wort fermentability. In

Table 4.17 The influence of isothermally mashing two malts, at three different temperatures, on wort fermentability and content of nitrogenous substances (Hudson, 1975)

Mashing temperature		Malt 1 (Diastatic power, 33 °L; TN, 1.3%)		Malt 2 (Diastatic power, 90 °L; TN, 1.8%)	
		Ferm. (%)	TSN (mg/100 ml)	Ferm. (%)	TSN (mg/100 ml)
°C	°F				
68	155	72	73	77	96
65.5	150	76	78	86	106
63	145	79	84	88	113

Abbreviations; Ferm., fermentability. TSN, total soluble nitrogen. TN, total nitrogen content of the malt (% on dry).

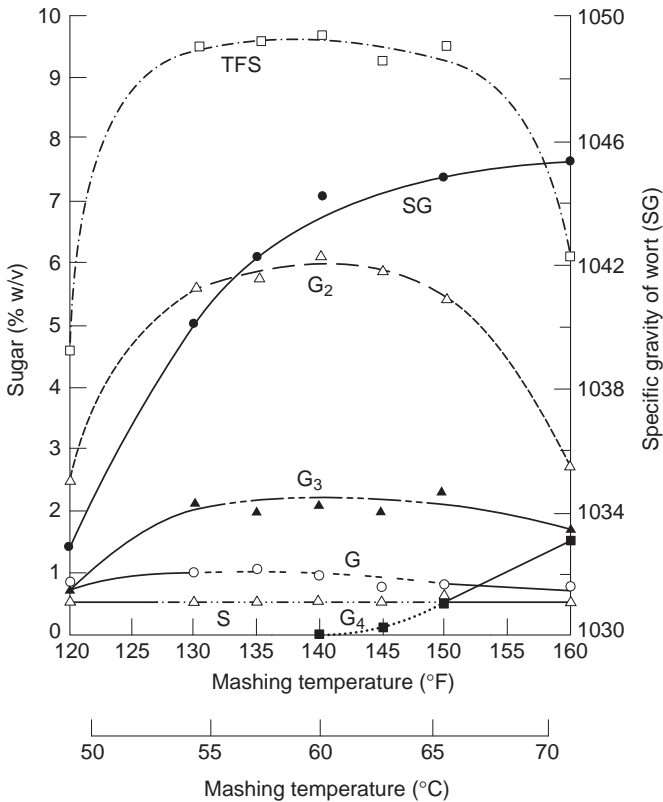

Fig. 4.20 The specific gravity of worts (●—● SG) and the levels of total fermentable sugars (□—□ TFS) and the sugars present in the worts prepared by isothermal 2h. mashes at the temperatures shown (after Taylor, 1974). Key to the sugars: G, glucose ○—○; G₂, maltose △—△; G₃, maltotriose ▲—▲; S, sucrose ▽—▽; G₄, maltotetraose ■—■. Only traces of fructose were detected.

Table 4.18 The influence of three mashing conditions on the β -glucan contents of worts prepared from three malts (Narziss, 1978). In the extended programme the malt grist was mashed in at 35 °C (95 °F). After a 30 min. rest the temperature was raised (during 15 min.) to 50 °C (122 °F) and this was held for 30 min. Temperature rests were subsequently at 65 °C (149 °F)/30 min., 70 °C (158 °F)/30 min. and 75 °C (167 °F)/5 min. In between the rests the temperature was increased at 1 °C (1.8 °F)/min. Total time, 180 min. The shortened mashes began at 50 °C (122 °F) or 65 °C (149 °F), and in each case the rest of the temperature programme was as before, so mashing times were 135 and 90 min. respectively

Malt modification			Excellent	Normal	Poor
Fine/coarse extract difference (% EBC)			1.1	2.0	3.8
Endo- β -glucanase activity (mPa/s)			0.343	0.315	0.096
Mashing in temperature °C	°F	Duration (min.)	β -Glucan yield (mg/100 g dry wt.)		
35	95	180	17	58	390
50	122	135	33	82	595
65	149	90	86	231	645

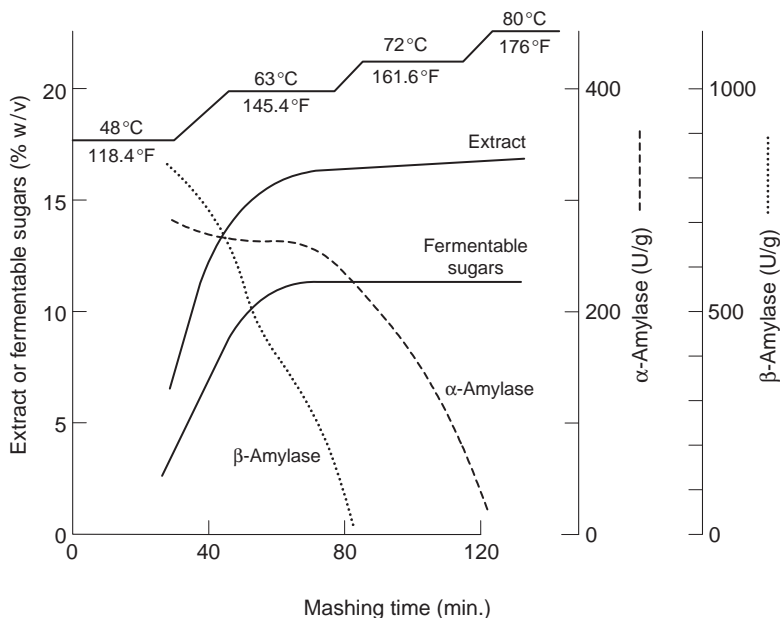

Fig. 4.21 The changing yields of extract and fermentable sugars (glucose, maltose and maltotriose) and the declining levels of α -amylase and β -amylase during temperature-programmed mashing (data of Stenholm *et al.*, 1996).

part this may be due to the fermentable sugars produced by this enzyme, but the faster liquefaction of the starch and faster production of dextrins produces more accessible substrate that β -amylase and other thermolabile enzymes can attack before they are heat inactivated. The problem with starches with high gelatinization temperatures is that by the time they have been liquefied at the necessarily high temperatures used, all the saccharogenic enzymes have been destroyed. Hence the need to cook and liquefy such starches, and adjuncts containing them, then to cool the mixture and mix it with malt at temperatures at which saccharification is still possible. The gelatinization temperature of malt starch can vary by as much as 6°C (10.8°F; Bourne, 1998). Worts prepared from these differing malts had varying fermentabilities.

4.4.3 Non-starch polysaccharides in mashing

The non-starch polysaccharides in the grist (NSP) are the fructans, the hemicelluloses, the gums and the holocellulose. Pectins seem to constitute negligible proportions of grist materials, although small amounts of combined uronic acids are present. Apart from sucrose (4.3), which seems to undergo little hydrolysis during mashing, the fate of the fructans is unknown. However, as the levels of fructose do not increase appreciably during mashing, it is likely that the fructans, which are very soluble, are not hydrolysed and so they remain with the unfermentable carbohydrates. In many plants fructans are metabolized by transglycosylation reactions. Holocellulose is the polysaccharide material which remains undissolved after extracting grist with hot water and solutions of caustic alkalis. This fraction comes mainly from the husk in malt, where it is associated with lignin and it makes up about 5% of barley. However, small amounts are found in all parts of grains. This material is thought not to undergo any alterations in mashing. There is no

evidence that pure cellulose (poly- β -(1,4)D-glucan) is present in malt, although some could be present in the holocellulose fraction, which contains combined glucose (4.1), mannose (4.8) and lesser amounts of galactose (4.9).

The remaining fractions, usually grouped as the gums and hemicelluloses, have been extensively studied (Briggs, 1998; MacGregor, 1990; Fincher, 1992; Letters, 1995a, b; Han and Schwarz, 1996). Together they make up about 10% of barley, but during malting the β -glucan component is substantially degraded while the pentosans increase. Gums are soluble in water, while the residual hemicelluloses are soluble in hot solutions of caustic alkali. If the extraction of gums is carried out with water of increasing temperatures the quantity of gum recovered increases at the expense of the residual hemicellulose. Thus these fractions are a series of materials with a range of solubilities. Chemically there are two major groups of substances in these fractions, the β -glucans, that have been exhaustively studied, and the less-studied pentosans. Minor amounts of other polysaccharides are probably present. These substances occur in the cell walls of barley and malt. The major, but not the only source of these substances, is the cell walls of the starchy endosperm in malt and barley and wheat adjuncts. In barley the carbohydrates of the endosperm cell walls contain about 70–75% β -glucan, 20–25% pentosan and 2–4% holocellulose.

During malting the β -glucan in the grain is preferentially degraded. In under-modified malts, chit malts, inhomogeneous malts and barley adjuncts the undegraded gums (and possibly hemicelluloses) present give rise to production problems if they are not adequately broken down during mashing. Problems with mashers made with wheat (or rye, or triticale) adjuncts are often caused by pentosans. Wort separation may be slow, the wort will be too viscous, extract recovery is likely to be low, beer filtration will be slow and will use large amounts of filter-aid material, the beers may become hazy and even deposit gels. These materials are also deposited if beer is frozen. However, other polysaccharides, including α -glucan dextrans (derived from starch), yeast glycogen and cell-wall glucomannans may also be involved (Forage and Letters, 1986; Letters, 1995a, b). Many of the problems attributed to β -glucans are probably partly due to pentosan materials (Han and Schwarz, 1996). These polysaccharides may also have beneficial effects on beer qualities, adding to palate-fullness and foam stability. Elevated levels of β -glucans indicate that malt is under-modified and so, in addition to other consequences, may lack adequate 'nitrogen (protein)-modification' and levels of the enzymes needed in mashing.

β -Glucans are families of molecules consisting of linear chains of β -D-glucopyranose units, of various lengths (molecular weights) linked in various ways. These chains are unsubstituted and, despite speculations to the contrary, there is no evidence for cross-linking via peptides or other materials. The major class in barley contains a mixture of 1,3- and 1,4-bonds in which about 90% consists of cellotriosyl and cellotetraosyl units (in which the respectively 3 and 4 glucose units are linked by β -(1,4)-bonds) are joined by single β -(1,3)-links (Fig. 4.22). In general the frequency of the (1,3)- to (1,4)-links is about 3 to 7, but this varies. This material resembles the seaweed polysaccharide lichenin. Some longer runs of β -(1,3)-links do occur and sequences of up to 14 β -(1,4)-linkages have been reported. In addition small amounts of an exclusively β -(1,3)-linked glucan, which resembles laminarin, are also present in barley. Apparently, its presence in malt has not been investigated. The chain lengths of the β -glucan molecules vary greatly, the longer chain materials giving rise to more brewing problems and very viscous solutions.

The enzymes involved in the hydrolytic breakdown of β -glucans during malting are indicated in Fig. 4.22. In mashing the amount of β -glucan that dissolves is increased by

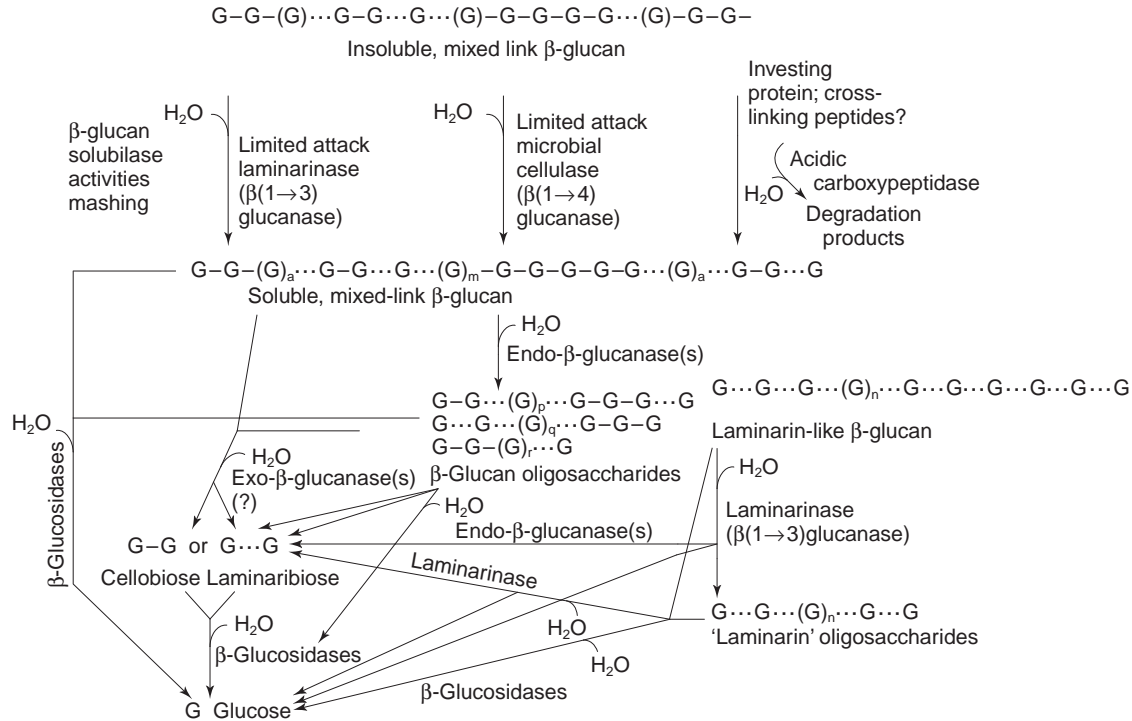

Fig. 4.22 A summary of the activities of the enzymes believed to be involved in the hydrolytic breakdown of β -glucans in germinating grain (Briggs, 1998). G, β -D-glucopyranose residue; - β -(1,4)-link; $\dots\dots$, β -(1,3)-link.

the activity of a heat-stable enzyme (or mixture of enzymes) now termed β -glucan solubilase (Luchsinger *et al.*, 1958; Scott, 1972; MacGregor and Yin, 1990; Bamforth *et al.*, 1997). The nature of this enzyme has not been established, and the enzyme activity has been attributed to a variety of enzymes acting separately or in concert such as β -(1,3)-glucanase, cellulase (β -(1,4)-glucanase), and peptidases. These activities may exert their effects by partial degradation of the glucan chains to shorter, more soluble fragments or to the removal of 'investing' materials associated with the cell wall structure (such as proteins and/or pentosans). The most significant enzymes are the *endo*- β -glucanases, which degrade the chains by random attack on the susceptible bonds, reducing the viscosity of their solutions. The malt *endo*- β -(1,3)-glucanase, sometimes called laminarinase, is relatively heat stable but will only attack polysaccharides within sequences of consecutive (1,3)- β -links. Two isozymes have been noted, with the same pH optimum of about 5.6. Their significance in mashing is uncertain. Malts contain small and variable amounts of cellulase(s), enzymes that can only attack β -glucan with consecutive runs of (1,4)-bonds. It is probable that much of this enzymic activity originates in microbes on the malt.

The more important enzyme, with two isozymes, is properly called *endo*-(1,3; 1,4)- β -glucan 4-glucanohydrolase, but is usually referred to as (malt) β -glucanase. These enzymes have pH optima of 4.7 and hydrolyse the β -(1,4)-bond adjacent to a substituting β -(1,3)-link, giving rise to oligosaccharides which, since these are not known to accumulate during mashing, are presumably rapidly degraded further by β -glucosidases. Only isozyme EII survives kilning and remains in malt (Fincher, 1992). This enzyme is heat labile and amounts remaining in pale malts are very variable. Low levels of malt β -glucanase can give rise to a need to supplement mashes with preparations of bacterial β -glucanases or fungal glucanases. The β -glucosidases, which can hydrolyse laminaribiose (4.19) and cellobiose (4.18) as well as other β -glucosides and which will attack the non-reducing chain ends of the β -glucan chains, seem to occur as isozymes having significantly different specificities. Their role in mashing is uninvestigated. The existence of *exo*- β -glucanases, which were postulated to attack the non-reducing chain ends and give rise to cellobiose (4.18) and laminaribiose (4.19), has not been confirmed. To be effective in mashing the malt used must have been carefully kilned to allow the survival of active β -glucanase. In many well-modified, strongly cured ale malts little or none of this enzyme remains. In all-malt mashes, it is not needed. The enzyme is needed when inhomogeneous or under-modified malt (including chit malt) is used or β -glucan-rich adjuncts are included in the grist. Then, because the enzyme is heat-labile, the mashing temperature programme must be adjusted to give the enzyme time to act. From a series of isothermal mashes, made at different temperatures, it is seen that at temperatures above 45 °C (113 °F) increasing amounts of β -glucan are extracted into the wort as higher temperatures are used (Fig. 4.23). This effect is due to the greater solubility of the glucans at higher temperatures combined with the earlier destruction of the β -glucanase at higher temperatures.

In commercial, isothermal mashes it is found that even at temperatures of about 65 °C (149 °F), it is beneficial to have appreciable β -glucanase activity in the malt if flake barley is being used as an adjunct even if, as has been estimated, the enzyme activity survives for only 2–5 min. Steamed flakes are probably the barley adjunct that most readily releases β -glucan during mashing while micronized barley releases least, perhaps because the polysaccharide is partly degraded by heat during the preparation of the adjunct. Elevated wort viscosity, which is an indication of faulty wort production, is often used as a warning that too much β -glucan is in the wort, and has even been used to 'measure' the

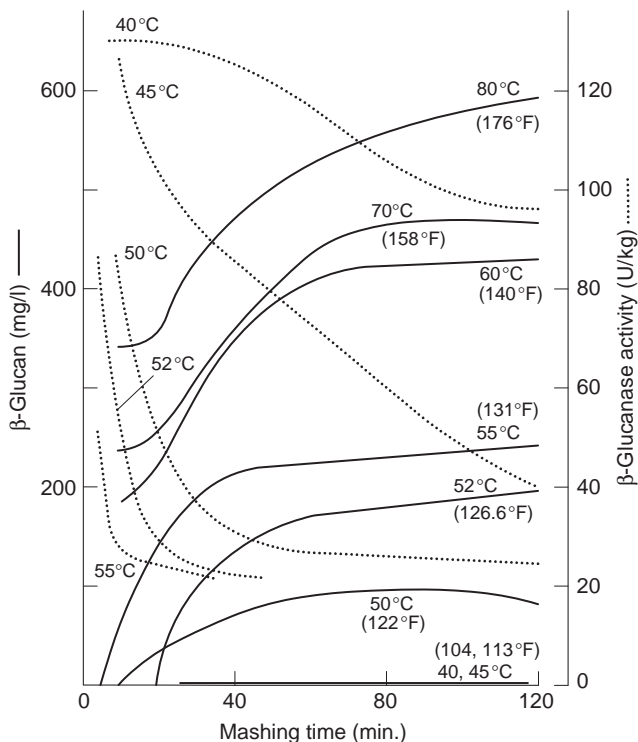

Fig. 4.23 The extraction, in time, of β -glucan, ———, and the activity of β -glucanase, , in isothermal mashes made at various temperatures (data of Home *et al.*, 1993).

polysaccharide present. This simplistic view is mistaken (Pierce, 1980; Bathgate and Dalglish, 1975). Many wort components contribute to its viscosity, including dextrans, pentosans, and sugars. The increase of viscosity with increasing β -glucan content is not linear but is more nearly a logarithmic relationship and the viscosity contributions of the wort components are not simply additive. Temperature-programmed mashing is attractive in that, by allowing a 'rest' at or near the temperature optimum of β -glucanase its activity is favoured (Table 4.18). However extended low-temperature rests will also allow other heat-labile enzymes, such as phosphatases, glycosidases and proteases, to continue acting, possibly with undesirable consequences, such as unduly elevated levels of TSN.

The fate of the pentosan polysaccharides in mashing has not been adequately investigated. Pentosans vary in their sizes and detailed structures (Briggs, 1998; Fincher, 1992). However, they are all based on chains of xylose (β -D-xylopyranose (4.10)) molecules joined through (1,4)-links. The xylose chains are variously substituted with arabinose (α -L-arabinofuranose (4.11)) units. A xylose residue may be unsubstituted, or be substituted on C-2, C-3 or in both positions. The substitutions occur irregularly along each chain. Arabinoxylans from malt tissues other than the starchy endosperm may also be substituted with D-glucuronic acid and perhaps galacturonic acid residues. In addition some of the arabinose substituents may have a single xylose residue attached. Many studies have treated the pentosans as though they were pure polysaccharides. However, a proportion of the arabinose units are substituted with phenolic acids, overwhelmingly ferulic acid (4.131), and the molecules are acetylated. It is assumed that the acetyl residues are attached to the xylose units. The

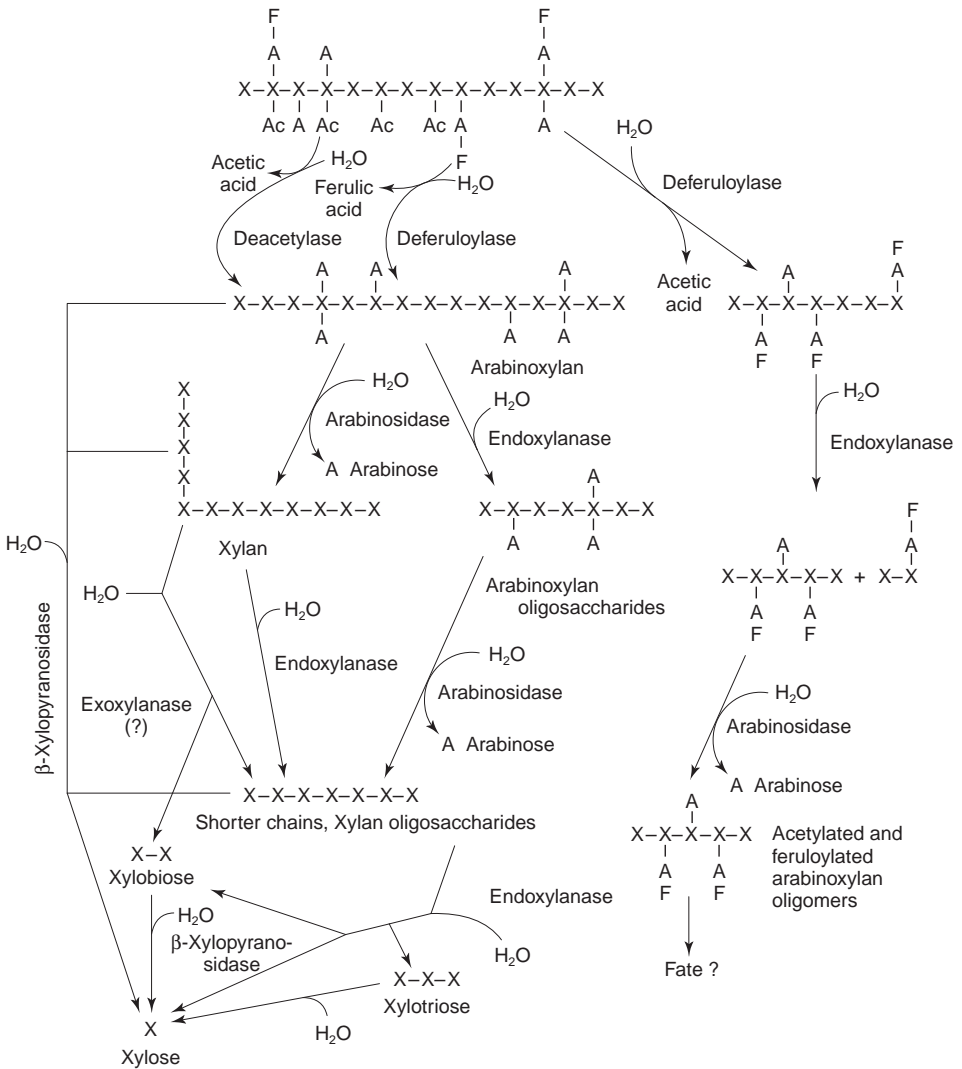

Fig. 4.24 A scheme of the activities of the enzymes believed to be involved in the hydrolytic breakdown of the grain pentosans during malting (Briggs, 1998). X, β -D-xylopyranose residues (4.10) linked (1,4) in chains. A, α -L-arabinofuranose residues (4.11) Ac and F, acetyl and feruloyl substituents, acetic acid and ferulic acid (4.131) attached to the polysaccharide through ester links.

consequences of these substitutions on the polysaccharides probably include increased hydrophobicity, with consequent hydrophobic binding between molecules, including some proteins, and decreased solubility.

Esterase enzymes must be present to remove the acylating (acetic acid and ferulic acid) substituents and so expose the polysaccharide to attack by carbohydrases. Mixtures of microbial esterases and carbohydrases act synergistically to break down pentosans. Pentosans bind large amounts of water, and it is this characteristic of the hemicellulose, present in the fine particles, that is believed to contribute to their slowing wort separation from mashes. The enzymes believed to be involved in the degradation of pentosans during malting are indicated in Fig. 4.24. The esterases are unstable in buffer solutions

over 30 °C (86 °F) (Humberstone and Briggs, 1998). However, feruloyl esterase is active in mashing with a temperature optimum of around 45 °C (113 °F) (McMurrough *et al.*, 1984, 1996; Narziss *et al.*, 1990).

The ferulic acid (**4.131**) liberated is a potential anti-oxidant and if decarboxylated during boiling or by bacteria or *pof*⁺ yeast strains, gives rise to 4-vinyl guaiacol (**4.134**, Fig. 4.33 on page 158), a strongly flavoured substance that is undesirable in most beers. Which other enzymes are involved in pentosan degradation during mashing is not clear, but the *endo*-xylanases, which are relatively heat stable, are probably involved and the greater amounts of arabinose (**4.11**) and xylose (**4.10**) found in temperature-programmed mashes, relative to isothermal infusion mashes, indicates that heat-labile glycosidases are active, at least at lower temperatures. Malt contains an inhibitor of xylanase (Debyser *et al.*, 1997b). Some 70–90% of malt gums are pentosans, the remainder being chiefly β -glucans. Quoted values are not consistent, but malt may contain 6.4–6.9% pentosan, of which 0.49–0.69% is water-soluble (Debyser *et al.*, 1997a). Some beers contain 0.3–0.5% (w/v) non-starch polysaccharides, (which may comprise 10% of the beer carbohydrate), of which c. 70% is pentosan, 23% is β -glucan and 7% is other materials (Han and Schwarz, 1996). In 15 other beers the arabinoxylans were in the range 514–4211 mg/l, while β -glucans were in the range 0.3–248 mg/l (Schwarz and Han, 1995).

4.4.4 Proteins, peptides and amino acids

In some analytical systems the nitrogen content of a material $\times 6.25$, (or some other factor), is reported as the protein content. This is incorrect and misleading, since many substances besides proteins contain nitrogen. Proteins consist primarily of chains of amino acids joined by peptide links (Figs 4.25 and 4.26). A protein may consist of one or more long polypeptide chains which may or may not be covalently cross-linked through disulphide bonds between two cysteine (**4.31**) residues (cystine; **4.32**). The chain(s) are folded together in particular ways and the biological activities of proteins, such as enzymes or lectins, depend on the folding being correct, that is the protein is in its 'native' state. If the folding is disrupted, for example by heat, then the biological activity is lost, the protein is 'denatured' and, if it was in solution, it may precipitate. Protein solution followed by thermal denaturation and precipitation occurs in temperature-programmed mashing and more aggregation and precipitation occurs during the hop-boil, giving the trub. Native proteins may be soluble or insoluble. Proteins may be substituted with various molecules, such as sugars in the case of glycoproteins or haem or other prosthetic groups in the cases of some enzymes, such as peroxidase.

The proteins of cereals are often considered in groups defined by their solubilities (Briggs, 1998). Globulins are soluble in pure water, while both albumins and globulins are soluble in salt solutions. Many enzymes occur in these soluble fractions but insoluble enzymes also occur in malt. The hordeins are soluble in hot solutions of aqueous alcohols, and their solubility is enhanced if reducing agents are also present (e.g. 70% ethanol containing 2-mercaptoethanol, or 60% *n*-propanol containing sodium borohydride). The glutelins are soluble only in solutions of strong alkalis. The last two fractions are largely either reserve materials or, in the case of the glutelins, they may have structural functions. Some cereal proteins have unexpected properties, for example, solubility in light petroleum (thionins). When degraded by hydrolysis proteins give rise to peptides, shorter chains of amino acids (Fig. 4.25), and eventually free amino acids (Fig. 4.26 (**4.24–4.49**)).

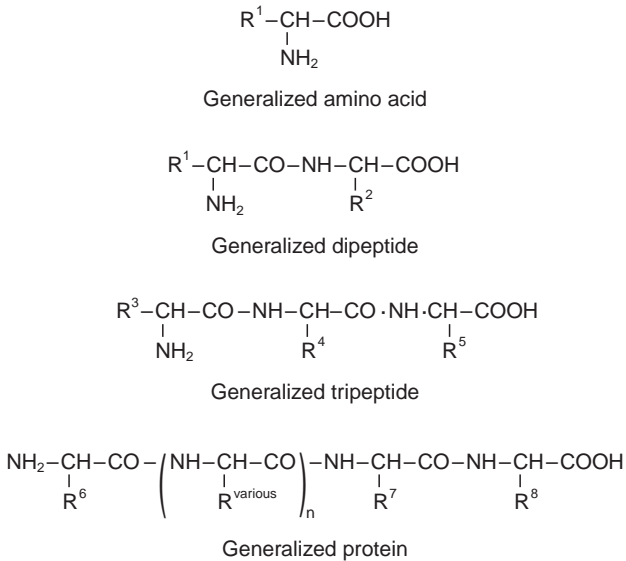

Fig. 4.25 Generalized formulae of an α -amino acid, a dipeptide, a tripeptide, and a section of a polypeptide chain, as found in proteins and their degradation products. The various side-chains, R, (Fig. 4.26) differ in their reactivities and in some cases may be substituted, for example with carbohydrates.

The amino acids differ in their properties and, when joined in peptide chains, their side-chains largely define the properties of the peptide or protein of which they form a part. The amino acid cysteine (4.31) is of interest since the thiol (-SH) on the side chain can be oxidized to give the 'di-amino acid' cystine, containing a disulphide link (4.32). Thus peptide chains can be cross-linked by covalent disulphide bonds formed by oxidizing cysteine residues in the chains, a fact that is probably important in polymerizing gel-proteins during mashing (Van den Berg and Van Eerde, 1982; Muller, 1995). Conversely these bonds may be split by reducing the disulphide bridges to pairs of thiols. The reduction may be brought about with sodium borohydride, or by thiol-disulphide exchange or by cleavage with bisulphite ions. Presumably, the enhanced rate of wort run-off caused by the experimental addition of bisulphites to mashes is caused by the altered structure of the proteins in the fine particles or *Oberteig* following the breaking of disulphide cross-links.

Thousands of proteins have been detected and from the brewing point of view it is usually most convenient to consider them in groups defined by particular properties. However, it is sometimes necessary to consider individual proteins, for example, because of their enzymic capabilities, or because they bind to particular sugars (i.e. they are lectins) or they bind to lipids or because they are involved in foam formation and stability, or because they are involved in binding to polyphenols giving adducts which can form hazes in beers. These 'haze-forming proteins' can be selectively removed from beer by adsorption onto silica hydrogels, or can be selectively degraded by proteolytic enzymes such as papain. These proteins and polypeptides appear to be distinct from those which add to the 'body' of the beer and those which help form and stabilize foam. Surprisingly some malt proteins or modified products (protein Z, 40 kDa, and LTP 1, a lipid transfer protein, 10 kDa, are examples) partly survive mashing and boiling and appear, sometimes partly modified, in beer.

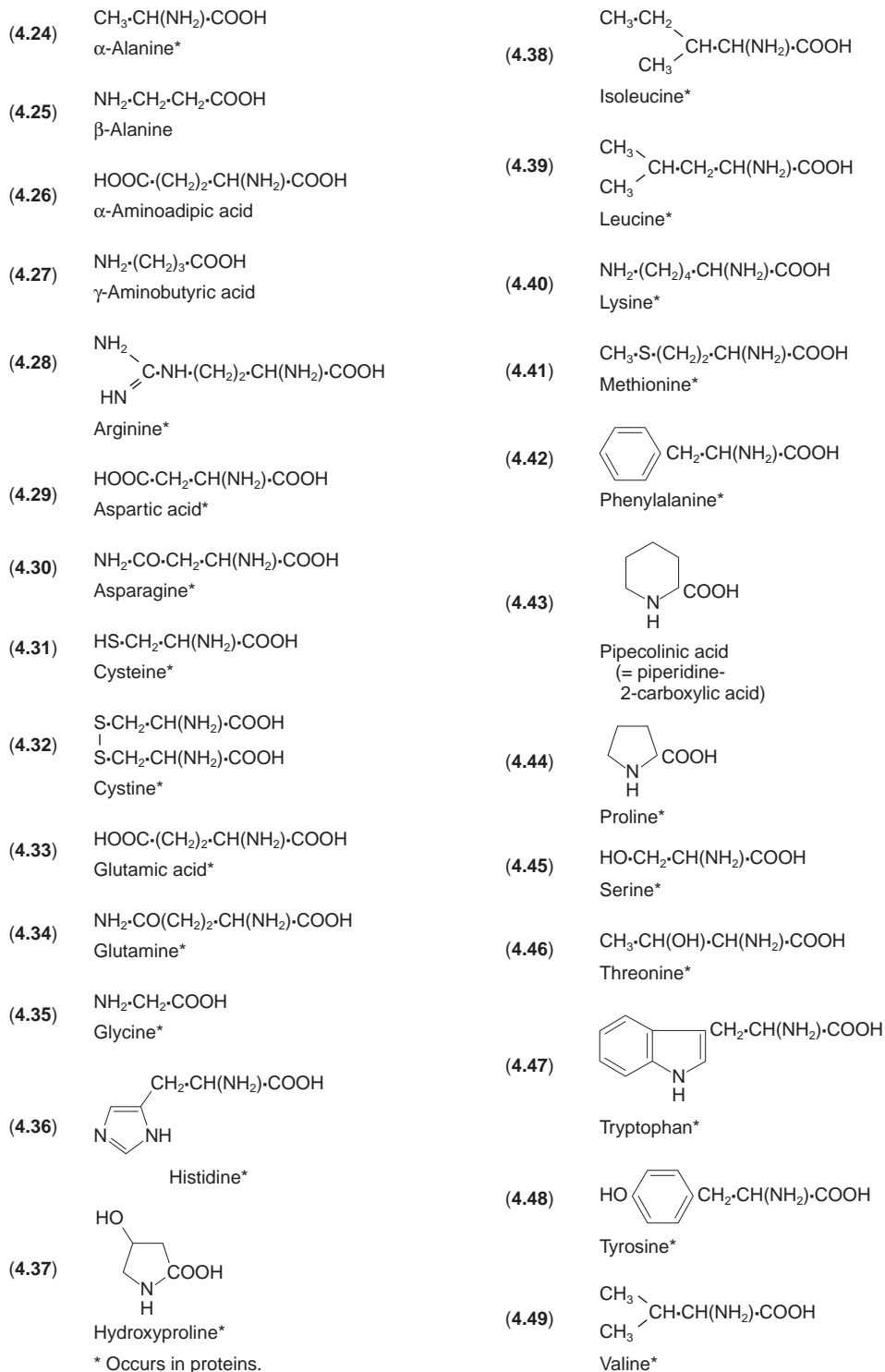

Fig. 4.26 The formulae of most common amino acids and the imino acids pipercolinic acid, proline and hydroxyproline.

It was believed that virtually all the soluble nitrogen-containing substances in wort, prepared by isothermal mashing at about 65 °C (149 °F), were preformed in malt. This is incorrect. The amounts of soluble nitrogen depend on the malt and the way that it is mashed. In mashes made at 65 °C (149 °F) about 50% of the total soluble nitrogen (TSN) and 30–50% of the free amino nitrogen (FAN) is formed by enzyme action during mashing. The mixture of malt enzymes involved in the hydrolytic breakdown of proteins is complex (Briggs, 1998; Enari, 1986; Enari *et al.*, 1964; Burger and Schroeder, 1976; Mikola *et al.*, 1972; Sopanen *et al.*, 1980). The major *endo*-peptidases, or proteases attack polypeptide chains at various particular locations. Both insoluble ('bound') and soluble ('free') enzyme activities have been detected. The most important proteases are thiol-dependent, have pH optima in the range 3–6.5 and contribute about 90% of the proteolytic activity. Metalloproteases (pH optima 5–8.5) provide most of the remaining activity, but serine proteases and aspartate proteases are also present.

About 42 soluble endopeptidases have been detected (Zhang and Jones, 1995a, b). In addition 4–5 amino-peptidases (pH optima 5.5–7.3, which attack peptide chains at their amino-termini) and at least four carboxypeptidases (pH optima 4–6, which attack peptide chains at the carboxyl termini) together with two alkaline peptidases (pH optima 8–10) are also present. In mashing, the proteases and the carboxypeptidases are the most important enzymes in generating soluble nitrogenous substances. There is normally an 'excess' of carboxypeptidase activity, and so the rate-limiting activity is due to limiting amounts of proteases. At the end of mashing there is always a substantial amount of protein remaining in the spent grains and so a lack of substrate is not what limits the generation of soluble nitrogen. During mashing ammonium ions are released as well as peptides and amino acids (Jones and Pierce, 1967; Pierce, 1982). Presumably the ammonium ions arise from the hydrolysis of glutamine (4.34) and asparagine (4.30) by amidases. Apparently transaminases are not active during mashing, but some glutamic acid (4.33) may be enzymically decarboxylated to give γ -amino butyric acid (4.27). With such a complex mixture of enzymes involved it is not surprising that alterations in mashing conditions can have dramatic effects on the patterns of nitrogenous substances present in the wort, including the proportions of amino acids. The reported temperature 'optima' of permanently soluble nitrogen (PSN), after 15 min., 1h. and 3h. mashing, were 61 °C (141.8 °F), 58 °C (136.4 °F) and 53 °C (127.4 °F) respectively while the corresponding values for formol-nitrogen were 59 °C (138.2 °F), 52 °C (125.6 °F) and 50 °C (122 °F).

Mash tun adjuncts are often used as sources of extract that will act as 'nitrogen diluents', that is, wort prepared using these adjuncts will contain less soluble nitrogen than an all-malt wort having the same extract content. However, mash tun adjuncts contribute some nitrogenous substances to the wort. Wheat adjuncts contribute polypeptide material that favours foam formation and stability, as do preparations of raw barley. Raw barley (like raw wheat) contains proteins that inhibit proteases from malt and some microbial enzymes. Thus the addition of a barley adjunct to a mash can reduce the level of wort-soluble nitrogen to a disproportionate extent and in barley brewing it is necessary to ensure that a sufficient amounts of a protease is used to ensure that enough soluble nitrogen is generated during mashing. In one trial the amounts of α -amino nitrogen in worts (as mg N/kg grist) were, with all malt, 949; with 16% malt replacement with the named adjunct, wheat, 763; rice, 821; maize, 832 (Jones, 1974).

The proteins and polypeptides that survive into the beer contribute to the 'body' and 'mouth-feel' of the beer, its foaming characteristics, and its susceptibility to haze formation. The colour of the beer is influenced by Maillard reactions between the

sugars and amino-compounds (including the amino acids) during the hop-boil, which give rise to coloured and flavoured substances. The proportions of the flavoured fermentation products made by yeast are dependent on the nitrogenous substances that are present. The rate of wort separation is reduced by the presence of inadequately degraded 'gel proteins' in the mash contributing to the fine particles and the *Oberteig* which impede the flow of the wort through the goods. In worts from all-malt mashes the levels of amino acids are nearly always adequate for good yeast growth. However, in worts made using mash tun and/or copper adjuncts the FAN levels may fall below the 100–140 mg/litre level, which is regarded as the minimum needed for trouble-free fermentations.

4.4.5 Nucleic acids and related substances

Nucleic acids make up 0.2–0.3% of malt. About 70% of the nucleic acid is deoxyribonucleic acid, DNA (4.50) and 30% ribonucleic acid, RNA (4.51). The enzymic hydrolysis of the nucleic acids first gives rise to nucleotides (base – sugar – phosphate), then nucleosides (base – sugar + inorganic phosphate) and finally free bases and sugars. In addition, the malt contains a variety of other nucleotides and derivatives including ATP (adenosine triphosphate, (4.53)), NAD⁺ (nicotinamide adenine dinucleotide, (4.54)), UDPG (uridine diphosphate glucose, (4.55)) and so on. The nucleic acids are chains of alternating phosphate and sugar (ribose (4.12) or deoxyribose (4.52)) residues, each sugar unit being substituted with a purine or a pyrimidine base (Fig. 4.27). Together these substances contribute 8–9% to the total nitrogen content of malt. During mashing the degradation of the more complex materials appears to be nearly complete, the products in the wort being free bases (adenine (4.56), guanine (4.57), cytosine (4.58), uracil (4.59) and thymine (4.60)) or breakdown products such as allantoin (4.61), hypoxanthine (4.62) and xanthine (4.63). The related nucleosides (e.g. adenosine, guanosine) and deoxynucleosides, in which the bases are attached to ribose or deoxyribose, are also present, as are smaller amounts of nucleotides. (Briggs, 1998; Ziegler and Piendl, 1976).

Several nucleases are present in malt and these are sufficiently stable to ensure the complete hydrolysis of the nucleic acids to nucleotides, molecules in which the nucleoside structures (base-sugar) are phosphorylated (base-sugar-phosphate) on the sugar residues in various positions. The phosphatase (nucleotidase) enzymes are also active as dephosphorylation of the nucleotides to nucleosides proceeds during mashing. The nucleosidases, which hydrolyse nucleosides to their constituent bases and sugars, are evidently more heat labile since highly kilned malts give relatively more nucleosides to free bases when mashed, compared to lightly kilned malt and mashing at higher temperatures gives worts richer in nucleosides. Some nucleic acid breakdown products are known to have flavour-enhancing properties, but the amounts reaching beer are so small that they can have only a marginal effect. Yeast probably uses the free bases to support growth in the initial stages of fermentation.

4.4.6 Miscellaneous substances containing nitrogen

A wide range of nitrogen-containing substances, besides proteins, peptides and amino acids, occur in malt and wort in widely differing amounts (Briggs, 1998; Engan, 1981; MacWilliam, 1968; Fig. 4.28). Ammonia, as ammonium ions, and many amines, often formed by the decarboxylation of amino acids, are found in worts. Thus glycine (4.35)

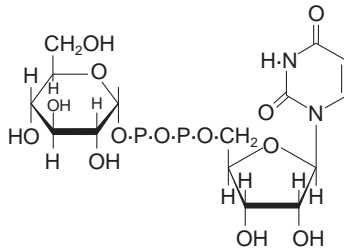
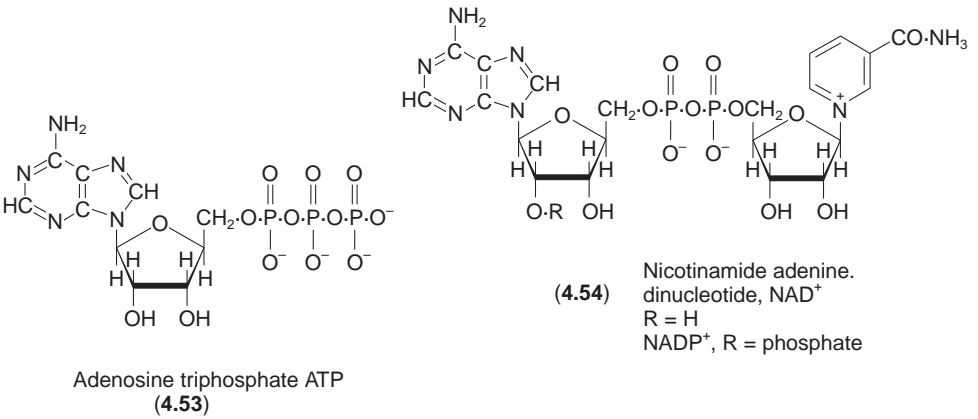
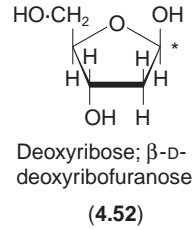
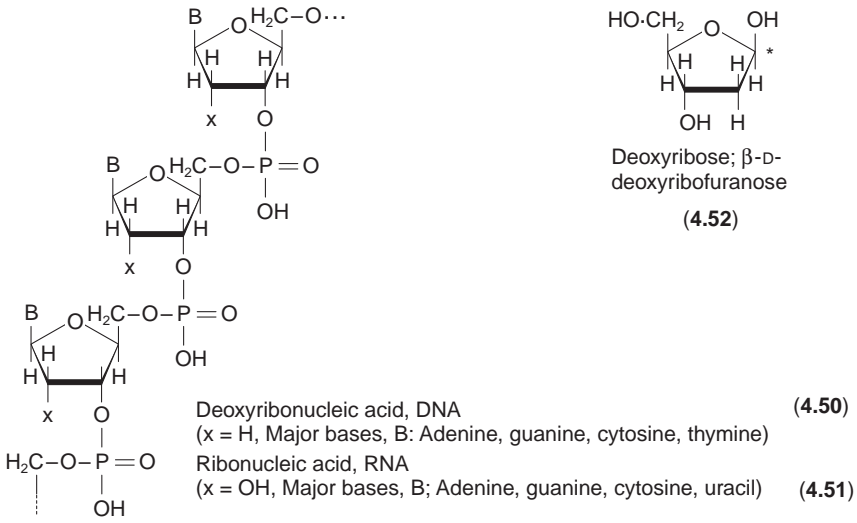

(4.55) Uridine diphosphate glucose, UDPG

Fig. 4.27 The structures of the nucleic acids, the purine and pyrimidine bases and the breakdown products allantoin, xanthine and hypoxanthine and of three chemically related cofactors.

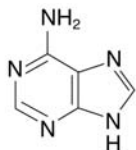
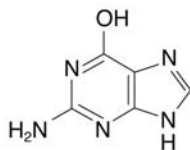
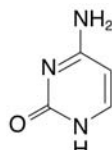
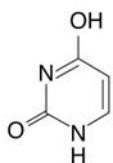
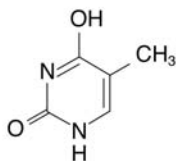
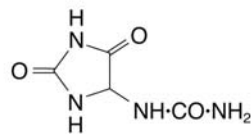
(4.56) Adenine
(α purine)(4.57) Guanine
(α purine)(4.58) Cytosine
(α pyrimidine)(4.59) Uracil
(α pyrimidine)(4.60) Thymine
(α pyrimidine)

(4.61) Allantoin

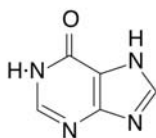

Hypoxanthine

(4.62)

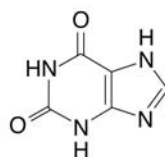

Xanthine

(4.63)

Fig. 4.27 Continued.

gives rise to methylamine (4.64), alanine (4.24) gives ethylamine (4.65), valine (4.49) gives isobutylamine (4.66), phenylalanine (4.42) β -phenylethylamine (4.67), tyrosine (4.48) tyramine (4.68), histidine (4.36) histamine (4.69), tryptophan (4.47) tryptamine (4.70), and proline (4.44) pyrrolidine (4.71). Similarly, the decarboxylation of arginine (4.28) yields agmatine (4.72), while ornithine (4.73) and lysine (4.40) give the diamines putrescine ((4.74); 1,4-diaminobutane) and cadaverine ((4.75) 1,5 diaminopentane), respectively. These last are precursors of spermine (4.76) and spermidine ((4.77) Briggs, 1978). The origins of dimethylamine (4.78), trimethylamine (4.79) *p*-hydroxybenzylamine (4.80) and gramine (4.81), butylamine and amylamine are less obvious. The methylated derivatives of tyramine (4.68), *N*-methyl-tyramine (4.82), di-*N*-methyl tyramine ((4.83), hordenine) and the quaternary tri-*N*-methyl-tyramine ((4.84), candicine) are also present.

A wide range of heterocyclic, N-containing substances also occurs in worts prepared using dark or roasted malts or adjuncts. Various other N-containing substances are also vitamins and/or yeast growth factors. Other substances, which should be present in only tiny amounts or be absent, include nitrosoamines and hydrocyanic (prussic) acid (Fig. 4.28). Nitrosamines can arise when malt is kilned and oxides of nitrogen are present in the air. Using modern malting techniques these substances should be nearly absent. The compound originally attracting interest was N-nitrosodimethylamine (NDMA, (4.85)), which was formed on the surface of the malt, but other substances, such as N-nitrosoproline have subsequently been detected. Barley malts contain widely variable amounts of cyanogenic glycosides, such as epi-heterodendrin (4.86). The amounts formed during malting are strongly influenced by the barley variety. This compound can be hydrolysed to glucose and isobutyraldehyde cyanohydrin by the enzyme β -glucosidase, then the cyanohydrin breaks down to isobutyraldehyde and hydrocyanic acid. Traces of this acid have been reported in beers, but the levels present are insignificant. This is not the case in distilleries, when the acid can give rise to urethane (ethyl carbamate, (4.87)). Some sorghum malts contain very large amounts of dhurrin (4.88), another cyanogenic glycoside, and in these cases there is a clear risk that significant levels of hydrocyanic acid (HCN) may reach beers made from them (Briggs, 1998). As with barley the amount of cyanogenic glycoside present in the sorghum malt is strongly influenced by the variety.

4.4.7 Vitamins and yeast growth factors

Many of the growth factors needed by yeast contain nitrogen (Table 4.19; Fig. 4.29). In addition to the substances mentioned in this section brewer's yeast needs some sterols and unsaturated fatty acids for growth, after periods of anaerobic growth (Chapter 12). The quantities of vitamins reported in worts vary widely. In part these discrepancies probably represent real differences and in part are caused by difficulties with the bioassays used in the estimations. Many of these substances occur combined in various ways and these may or may not be broken down during mashing and may or may not be available to yeast. Thus folic acid (4.89) and related compounds occur in various forms, nicotinic acid occurs (as nicotinamide (4.90)) in the oxidation/reduction cofactors NAD⁺ (4.54) and NADP⁺, and *myo*-inositol (4.91) occurs combined with phosphate in phytic acid (4.156) and in some lipids (e.g. (4.122)). Riboflavin (4.92) occurs in the oxidation/reduction co-factors flavin mononucleotide (FMN, (4.93)) and flavin adenine dinucleotide (FAD, (4.94)), while thiamine (4.95) occurs as thiamine pyrophosphate.

Malt contains some fat-soluble vitamin precursors (Briggs, 1998), of which the tocopherols (vitamin E) might be significant, but it is unclear if any of these reach the hopped wort. The water soluble vitamins are significant (Table 4.19). Although vitamin C (ascorbic acid (4.96) and dehydroascorbic acid (4.97)) are present in green malt these materials are destroyed during kilning. Traces of vitamin B₁₂ have sometimes been found in malt, but the significance is unclear. It is not known what alterations may occur to vitamins and their precursor substances during mashing. At first it seems strange that so many uncertainties surround these compounds. The reason is probably that the levels present in conventional worts rarely or never limit yeast growth and fermentation, and so there is no stimulus for investigating their origins and fates. However, problems with fermentations have been encountered with high-adjunct, barley brews and these have been overcome by the addition of yeast extracts to the worts. Various water soluble vitamins and growth factors are known to be present in these complex preparations and so

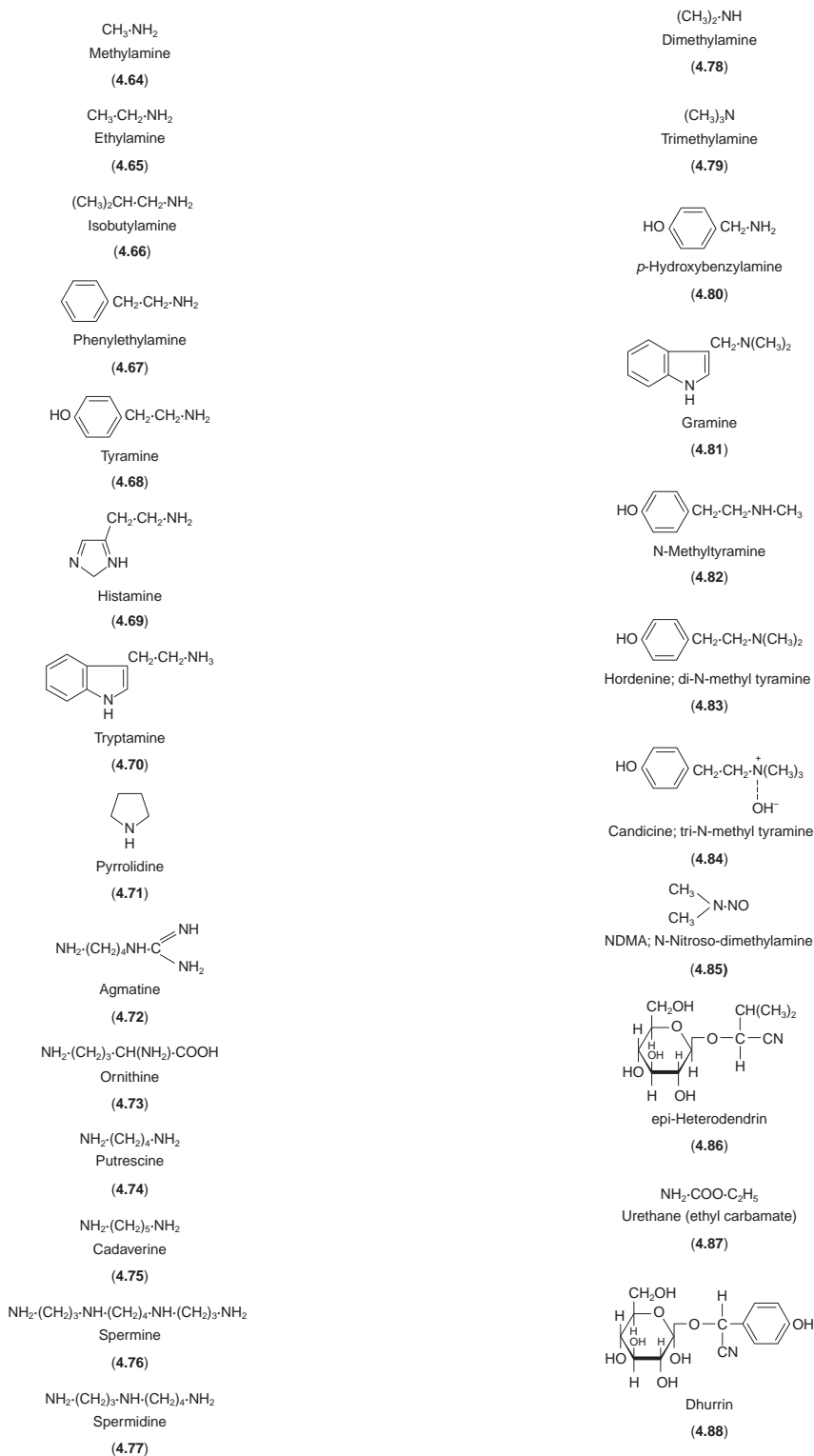

Fig. 4.28 Some amines and other nitrogenous substances found in wort.

Table 4.19 Vitamins and yeast growth factors in wort (Briggs *et al.*, 1981; MacWilliam, 1968). The amounts of these factors present in worts are likely to vary considerably with the different compositions of grists and with differing wort concentrations

Growth factor or vitamin	Reported concentrations
Choline (4.101)	20–25 mg/100 ml
<i>myo</i> -Inositol (4.91) bound	1–6 mg/100 ml
free	1.5–3.5 mg/100 ml
Thiamine ((4.95); aneurine; vitamin B ₁)	28–75 (155) µg/100 ml
Riboflavin ((4.92); vitamin B ₂)	33–90 µg/100 ml
Folic acid (4.89), and related substances	10–13 µg/100 ml
Nicotinic acid ((4.90); niacin)	0.8–1.8 mg/100 ml
Pyridoxin ((4.100); pyridoxal, pyridoxamine, vit. B ₆)	59–105 µg/100 ml
Biotin (4.98)	0.8–1.2 µg/100 ml
Pantothenic acid (4.99)	48–98 µg/100 ml

these may be partly or wholly responsible for the improved fermentation performance of the yeast.

4.4.8 Lipids in mashing

Malt contains about 3.5% of lipids and is the major source of lipids in all-malt beers. Most adjuncts contain less lipid than malt, and specifications often specify the maximum that any batch may contain. They also contribute some lipid to the wort. Older reports often quoted low values for lipid contents, because only the non-polar materials were extracted by the methods then in use. Malt lipids are a complex mixture containing hydrocarbons, fatty acid esters, sterol esters, esterified steryl glycosides, waxy esters, monoglycerides, diglycerides and triglycerides, free sterols, free fatty acids, long chain alcohols, phospholipids, glycolipids, carotenoids and tocopherols (Figs 4.30 and 4.31; Table 4.20; Anness, 1984; Briggs, 1978, 1998; MacWilliam, 1968; Morrison, 1978, 1988). Brewing science has concentrated on relatively few of these groups of substances.

Using the analysis of fatty acids, the lipid types present in a free wort (as mg fatty acid/litre) were reported to be: phospholipids+glycolipids 14.8, monoglycerides, 1.7; diglycerides, 2.8; triglycerides, 15.3; free fatty acids, 28.4; steryl esters, 1.0 and unknowns, 0.3 (Table 4.21). These analyses do not record lipids lacking fatty acids in their make-up. Triglycerides (**4.102**) predominate in malt, but free fatty acids (**4.107–4.113**) predominate in the wort. The amounts of lipid extracted into wort is increased by using better modified malts, finer grinding, higher mashing and sparging temperatures, thinner mash beds during wort separation, careless and excessive raking in the lauter tun, by using smaller proportions of adjuncts, and by running off faster, by ‘squeezing’ the mash to recover residual extract, or by adopting other techniques to maximize extract recovery. Much of the lipid in a mash is present as oil droplets spread among the grist particles. In general, more turbid worts carry more lipids and techniques are usually adopted to minimize turbidity and the amounts of lipid remaining in the wort, even though their presence can increase the fermentation rate (Chapter 12). Thus the wort is recirculated through the filter bed until it ‘runs bright’, or it can be filtered through kieselguhr or centrifuged. The last two treatments are probably not much used on the production scale.

More lipids are also removed at later stages of the brewing process, for instance, during wort boiling and clarification, but it is sound practice to obtain the sweet worts as

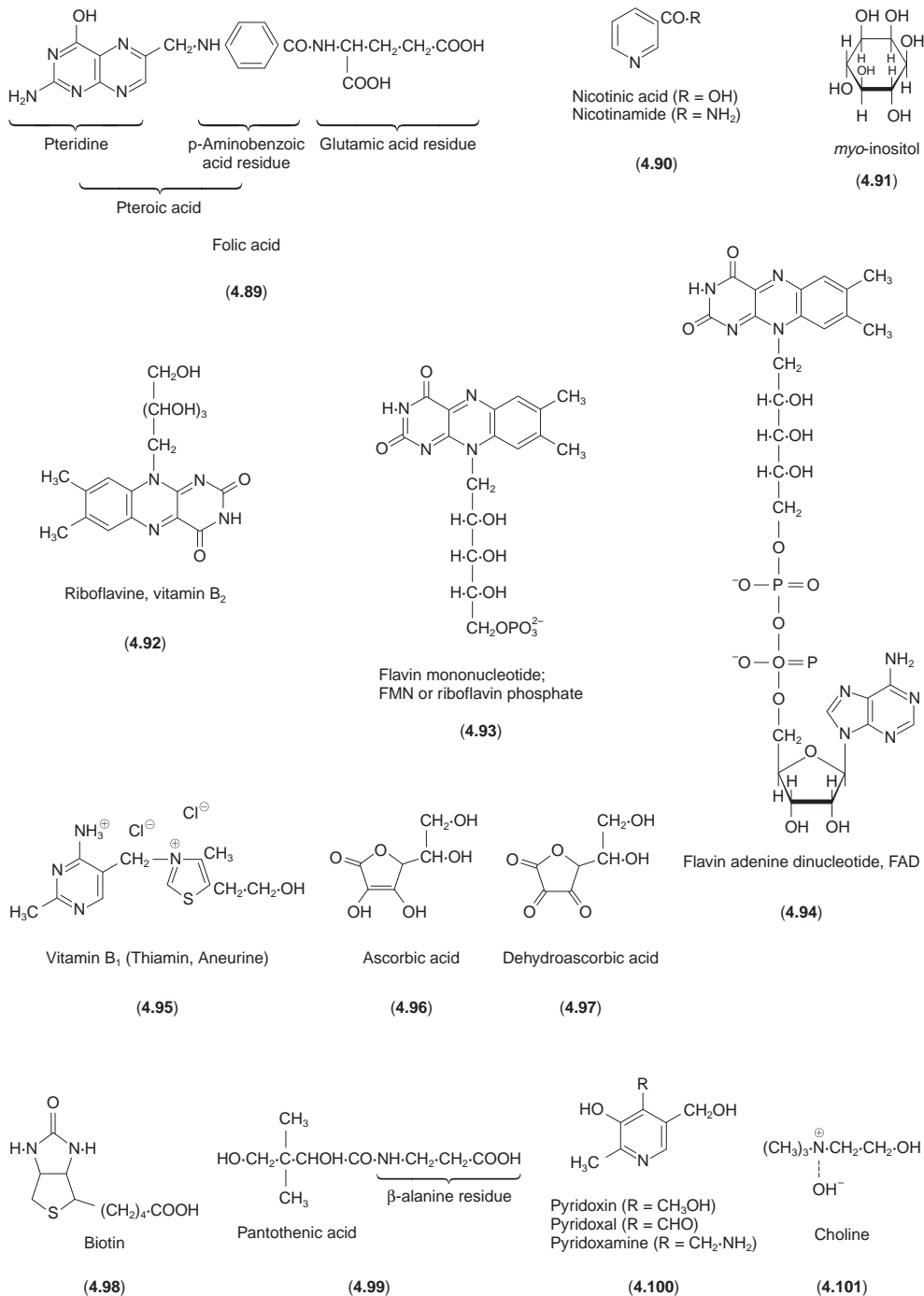
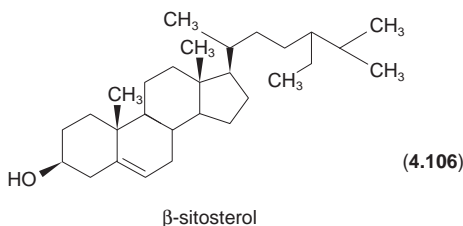
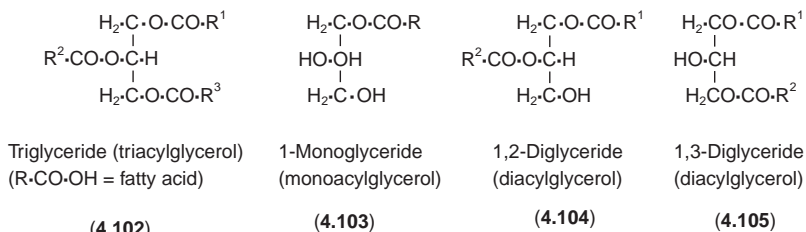

Fig. 4.29 Some water-soluble vitamins and yeast growth factors that occur in wort and ascorbic and dehydroascorbic acids, which occur in green malt.

**Common fatty acids**

$\text{CH}_3(\text{CH}_2)_{12}\text{COOH}$	Myristic acid (14:0)	(4.107)
$\text{CH}_3(\text{CH}_2)_{14}\text{COOH}$	Palmitic acid (16:0)	(4.108)
$\text{CH}_3(\text{CH}_2)_5\text{CH}=\text{CH}(\text{CH}_2)_7\text{COOH}$	Palmitoleic acid (16:1)	(4.109)
$\text{CH}_3(\text{CH}_2)_{16}\text{COOH}$	Stearic acid (18:0)	(4.110)
$\text{CH}_3(\text{CH}_2)_7\text{CH}=\text{CH}(\text{CH}_2)_7\text{COOH}$	Oleic acid (18:1)	(4.111)
$\text{CH}_3(\text{CH}_2)_4\text{CH}=\text{CH}\cdot\text{CH}_2\cdot\text{CH}=\text{CH}(\text{CH}_2)_7\text{COOH}$	Linoleic acid (18:2)	(4.112)
$\text{CH}_3\text{CH}_2\text{CH}=\text{CH}\cdot\text{CH}_2\cdot\text{CH}=\text{CH}\cdot\text{CH}_2\cdot\text{CH}=\text{CH}(\text{CH}_2)_7\text{COOH}$	Linolenic acid (18:3)	(4.113)

Fig. 4.30 Non-polar lipids and fatty acids, with β-sitosterol as an example of a sterol. R.CO.O represents an esterified fatty acid residue.

bright as possible. Less than 5% of malt lipids are extracted into the sweet wort, the amount depending on the equipment used and the way it is operated. The amounts of malt lipids in sweet worts (expressed as % of the lipid in the malt) prepared using a traditional mash tun, a lauter tun and a traditional mash filter were 0.3%, 1.0% and 4.5% respectively (Anness and Reid, 1985). In contrast, the new 2001 filter releases relatively little lipid into the wort (Letters, 1994). In another report the lipid contents of worts prepared using a deep bed mash tun, a lauter tun, a Strainmaster and a traditional mash filter were 10, 50, 150 and 400 mg/litre, respectively (Whitair *et al.*, 1983).

Lipids have a number of effects in brewing but there are disagreements about the details, probably because different criteria and lipid fractions have been used in the studies (Letters, 1992, 1994; Letters *et al.*, 1986; Isherwood *et al.*, 1977; Wainwright, 1980). Unsaturated fatty acids and sterols (Fig. 4.30) have a beneficial effect on yeast, improving its fermentation performance, its viability and its resistance to high alcohol contents, such as occur in high-gravity brewing. These materials can only be produced by yeast in sufficient amounts under aerobic conditions. When turbid worts, which contain elevated amounts of lipids, reach the fermenter it is often found that fermentation is enhanced. It seems that, in the amounts found normally in beers lipids do not influence gushing. On the other hand the lysophospholipids (such as lysophosphatidyl choline, (4.23)) complexed with amylose in starch and the lysophospholipids together with the free fatty acids present in mashes can slow down starch gelatinization and impede amylolysis and the degradation of complexed dextrans. As the lipid-polysaccharide complexes do not give positive iodine tests these can be misleading when estimating the amounts of starch remaining in the spent grains.

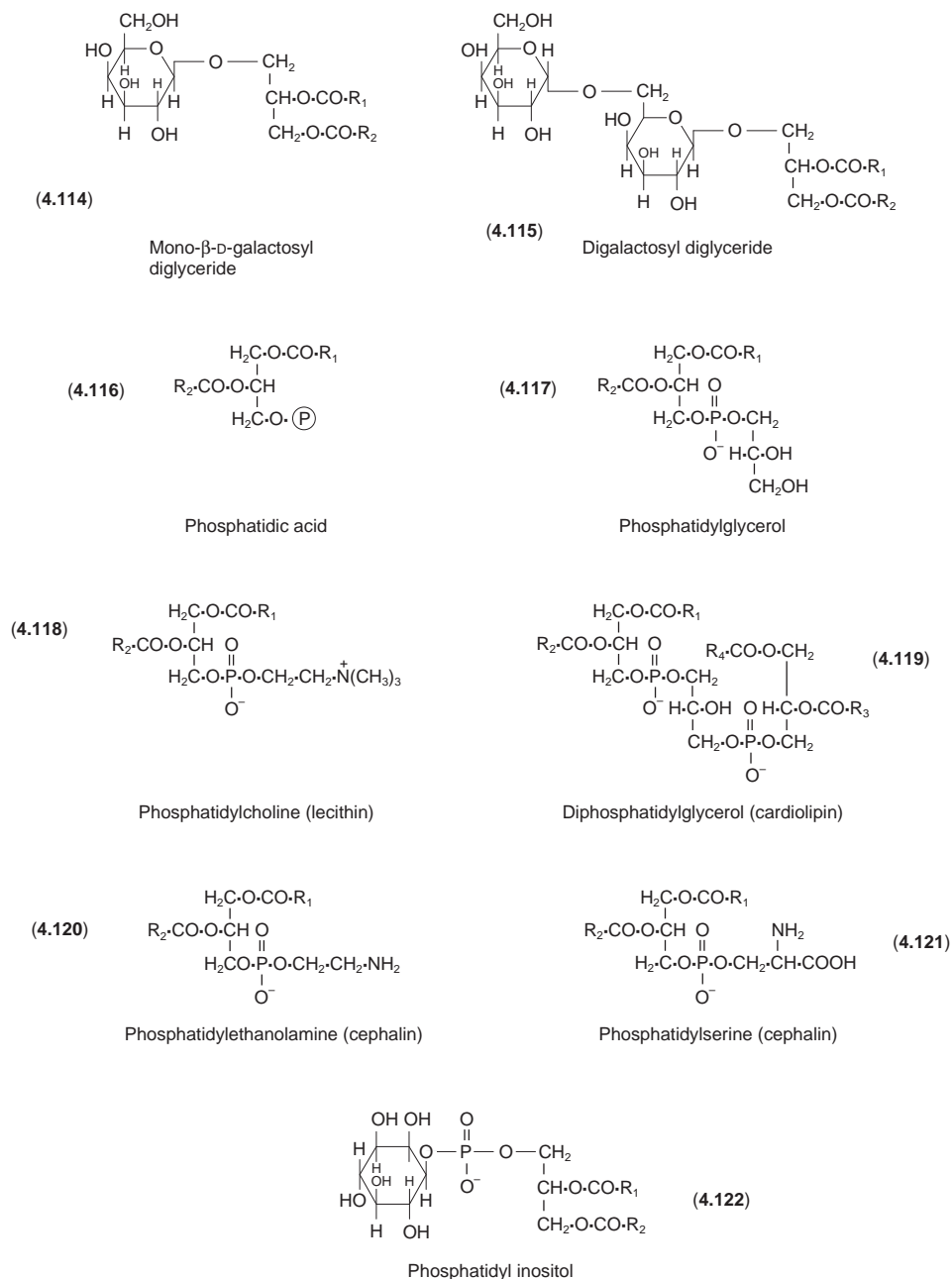

Fig. 4.31 Examples of polar phospholipids and glycolipids (see also 4.23), (P) phosphate residue.

The addition of most preparations of lipids to beer reduces head formation and survival. The effects are complex, both because different mixtures of lipids have different effects and because lipid binding proteins (such as LTP1, a 10 kDa albumin) can survive into beer and ‘mask’ the effects of the lipids. Indeed, LTP1 constitutes a major proportion of the protein in foam. At least in some combinations, mixtures of different groups of lipids act synergistically to destroy foam when added experimentally to beer. Possibly

Table 4.20 Analyses of the lipid classes in two barley malts (Anness, 1984). The results are expressed as the fatty acids in each fraction per unit dry weight, (mg fatty acids/g dry weight). This type of analysis does not reveal the presence of lipids that do not contain fatty acids (e.g. free sterols)

Class of lipid	Weeah malt	Sonja malt
PHOSPHOLIPIDS (4.116–4.122)	2.4	3.2
GLYCOLIPIDS		
Digalactosyl monoglyceride	0.9	1.1
Digalactosyl diglyceride (4.115)	1.0	1.1
Monogalactosyl monoglyceride	0.2	0.1
Monogalactosyl diglyceride (4.114)	0.4	0.7
NEUTRAL LIPIDS		
Acylsterylglucosides	0	0
Monoglycerides (4.103)	0.3	0.3
Free fatty acids (4.107–4.113)	2.0	2.2
Diglycerides (4.104, 4.105)	1.0	1.2
Triglycerides (4.102)	19.8	25.3
Steryl esters	0.3	0.7

Table 4.21 Examples of the major total fatty acids of the lipids found in the grist, the spent grains and the sweet wort from (A) a mash prepared in a mash tun and (B) a mash separated in a lauter tun (Anness and Reed, 1985)

Sample	Fatty acid composition (%)				
	16:0 (4.108)	18:0 (4.110)	18:1 (4.111)	18:2 (4.112)	18:3 (4.113)
(A)					
Grist	21.2	0.8	9.7	58.4	9.9
Spent grains	24.8	1.2	10.1	54.5	9.3
Sweet wort	47.6	5.2	5.9	36.3	4.9
(B)					
Grist	20.8	1.0	11.3	57.9	8.9
Spent grains	25.2	0.8	10.5	57.5	6.0
Sweet wort	41.4	3.4	5.4	45.3	4.4

lipid levels in beers are normally so low that their effects on foam are negligible. The majority view is that the lipids are important, and that it is the lipids in the last runnings from the mash that are responsible for their ability to reduce foam stability.

Great interest attaches to the effects of lipids on flavour. The concentrations of the free fatty acids in beer appear to be too low to have direct effects. However, different levels of free fatty acids can influence the production of esters by yeast during fermentation and so alter the flavour of the beer produced. The greatest interest is in the effects of lipids on the flavour deterioration of beer during storage. During mashing some lipid seems to disappear because it is oxidized, by oxygen dissolved in the mash, to more polar substances, some of which reach the beer and, during storage, give rise to unsaturated aldehydes (such as *trans*-2 nonenal and *trans*-2, *cis*-6-nonadienal) which give the beer an unpleasant, cardboard like flavour. The chain of reactions is complicated (Fig. 4.32). Lipids are hydrolysed by lipases (lipid hydrolases) and esterases to free fatty acids, a major proportion of which is linoleic (4.112) and linolenic (4.113) acids, which are

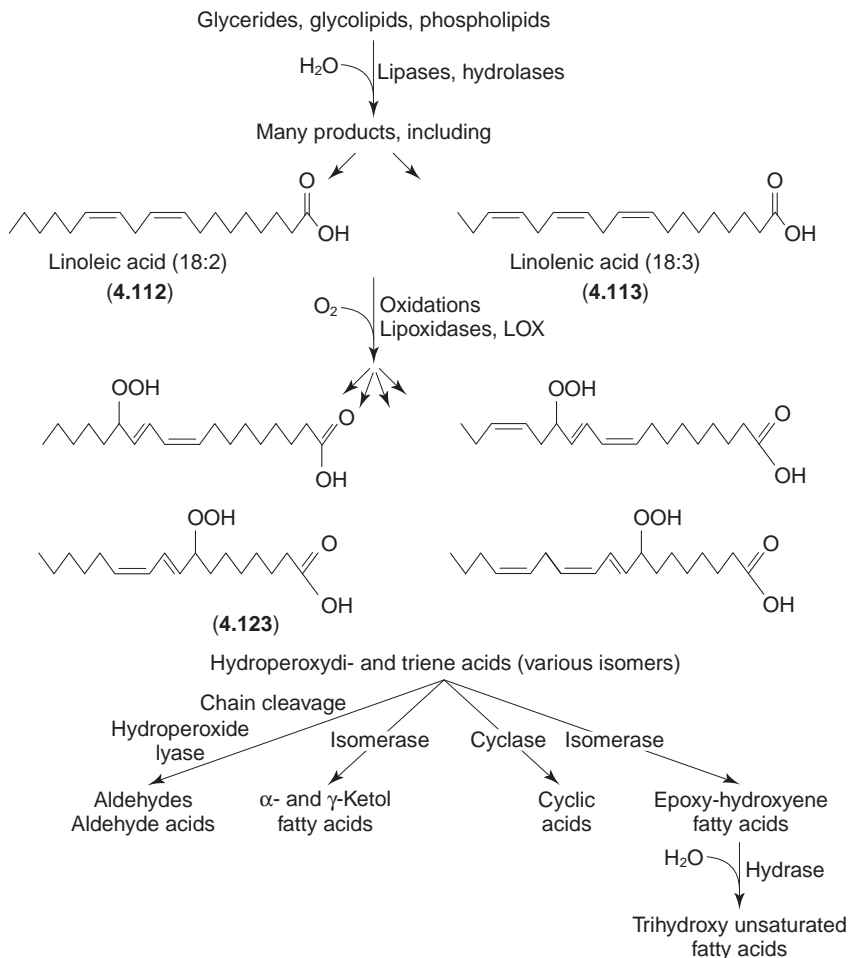

Fig. 4.32 Possible stages in the oxidative breakdown of the major unsaturated fatty acids during mashing (after Briggs, 1978; Gardner, 1988). The number of possible products is very large indeed.

It is thought that the unsaturated trihydroxy-fatty acids are the precursors of staling flavour compounds in beers.

unsaturated. Some of these acids may have been oxidized while still combined in the original lipid. Malt acrospires are rich in lipases and lipid degrading enzymes. Lipases are active to some extent during mashing. The unsaturated acids are partly oxidized by oxygen in the presence of lipoxidase enzymes (LOX, two isoenzymes occur), and perhaps peroxidase, giving rise to several unsaturated hydroperoxides (4.123). Some autoxidation may also occur, but it seems that enzyme-catalysed oxidation is the most important, and this may be reduced by reducing the mash pH from 5.5 to 5.0 (Kobayashi *et al.*, 1993). The diene and triene systems of linoleic (4.112) and linolenic (4.113) acids are very readily oxidized.

Under the influence of hydroperoxide isomerases (which are relatively heat stable) and other enzymes a complex mixture of substances is formed, including saturated and unsaturated aldehydes and aldehyde acids, ketols, cyclic compounds, epoxyhydroxyacids and trihydroxyfatty acids, including various trihydroxyoctadecenoic acid isomers (Fig. 4.32). The aldehydes contribute to a cardboard flavour, but most of these substances are

lost by evaporation during the hop-boil and the rest are reduced to the corresponding alcohols by the yeast. These alcohols are not oxidized during beer storage and they are not the source of the 'staling aldehydes' in beer. It seems that these arise, by some unknown mechanism, from the various unsaturated trihydroxyacids which are not retained in the mash, are easily water soluble and which survive into the beer (Möller-Hergt *et al.*, 1999). The trihydroxy fatty acids have foam-collapsing properties. Increasingly, ways to minimize oxidation during mashing are being sought, to minimize the formation of precursors of 'off-flavours'. Minimum quantities of fatty acid-containing lipids are extracted from mashes made at 62–64 °C (143.6–147.2 °F). The amounts extracted from mashes made at 68 °C (154.4 °F) are roughly double those extracted from the cooler mashes (Forch and Runkel, 1974).

4.4.9 Phenols

Cereal grains contain complex mixtures of phenols and polyphenols. Barley grain and malts have been most studied, but sorghum phenols have also been studied, especially in dark-grained, 'birdproof' cultivars. Barley and sorghum seem to be alone among the cereals in possessing polymeric flavanols. The phenols in barley vary widely in their complexity. Compounds such as tyrosine (4.48), tyramine (4.68) and hordenine (4.83) are present as are a range of phenolic acids. These may be divided into two groups, the substituted benzoic acids and the substituted cinnamic acids (Fig. 4.33; Briggs, 1998; McMurrrough *et al.*, 1984; 1996). Of the benzoic acids vanillic acid (4.127) is the most abundant in wort, while of the cinnamic acids ferulic acid (4.131) is the most abundant in malt (Table 4.22). The acids occur free and in combination, apparently as esters (as in chlorogenic acid (4.133) and glycosides). Ferulic acid occurs free and attached to some arabinose residues in pentosans and it is released into wort during mashing, with an optimum temperature of about 45 °C (113 °F). During boiling or under the influence of some bacteria and wild yeasts some ferulic acid is decarboxylated to yield 4-vinyl guaiacol (4.134) a substance which in most beers confers an undesirable flavour. However, in wheat beers the presence of this substance is desirable. In some barleys, and their malts, coloured anthocyanin pigments (delphinidin (4.135), cyanidin (4.136) and perhaps pelargonidin (4.137)) occur, either free or as glycosides, but these substances seem to have no significance in brewing.

Table 4.22 The concentrations of the major phenolic acids in an unboiled lager wort (McMurrrough *et al.*, 1984)

Benzoic acid derivatives	Concentration (mg/litre)
Gallic acid (4.125)	0.1
Protocatechuic acid (4.126)	0.5
4-Hydroxybenzoic acid (4.124)	0.6
Vanillic acid (4.127)	1.4
Syringic acid (4.128)	0.6
Cinnamic acid derivatives	
Caffeic acid (4.130)	0.1
<i>p</i> -Coumaric acid (4.129)	0.6
Ferulic acid (4.131)	1.3
Sinapic acid (4.132)	0.4
TOTAL	5.6 (mg/litre)

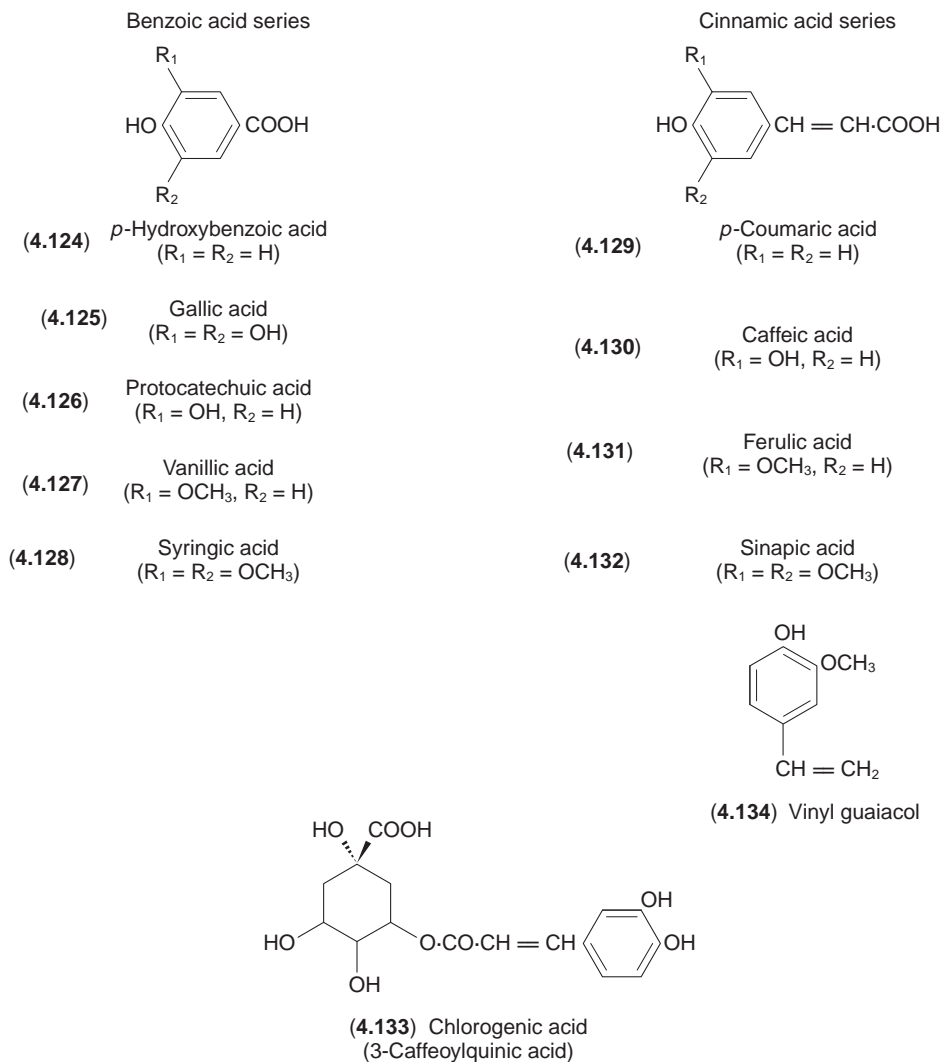

Fig. 4.33 Substituted benzoic and cinnamic acids and some related compounds that occur in sweet wort.

Of more significance are the colourless flavan-3-ols ((+)-catechin (4.138), (-)-epicatechin (4.139), (+)-gallocatechin (4.140) and epigallocatechin (4.141)) and related polymeric materials (Fig. 4.34). These four monomeric substances are not proanthocyanidins. In contrast, polymeric flavan-3-ol materials give rise to anthocyanin pigments when heated in acidic butanol in air. At first this was thought to be because they were monomeric flavan-3,4-diols, and so they were called leucoanthocyanins. This is not correct and at present they are usually called anthocyanogens by brewers and proanthocyanidins by chemists. As analytical methods have improved so the great complexity of this group of substances has been recognized. In a recent study dimers (7), trimers (19), tetramers (23), and pentamers (7) were recognized (Whittle *et al.*, 1999), and this total, of 56, may well increase as analytical methods are further refined. An example of a prodelphinidin pentamer (4.145) is shown in Fig. 4.35. In addition to the

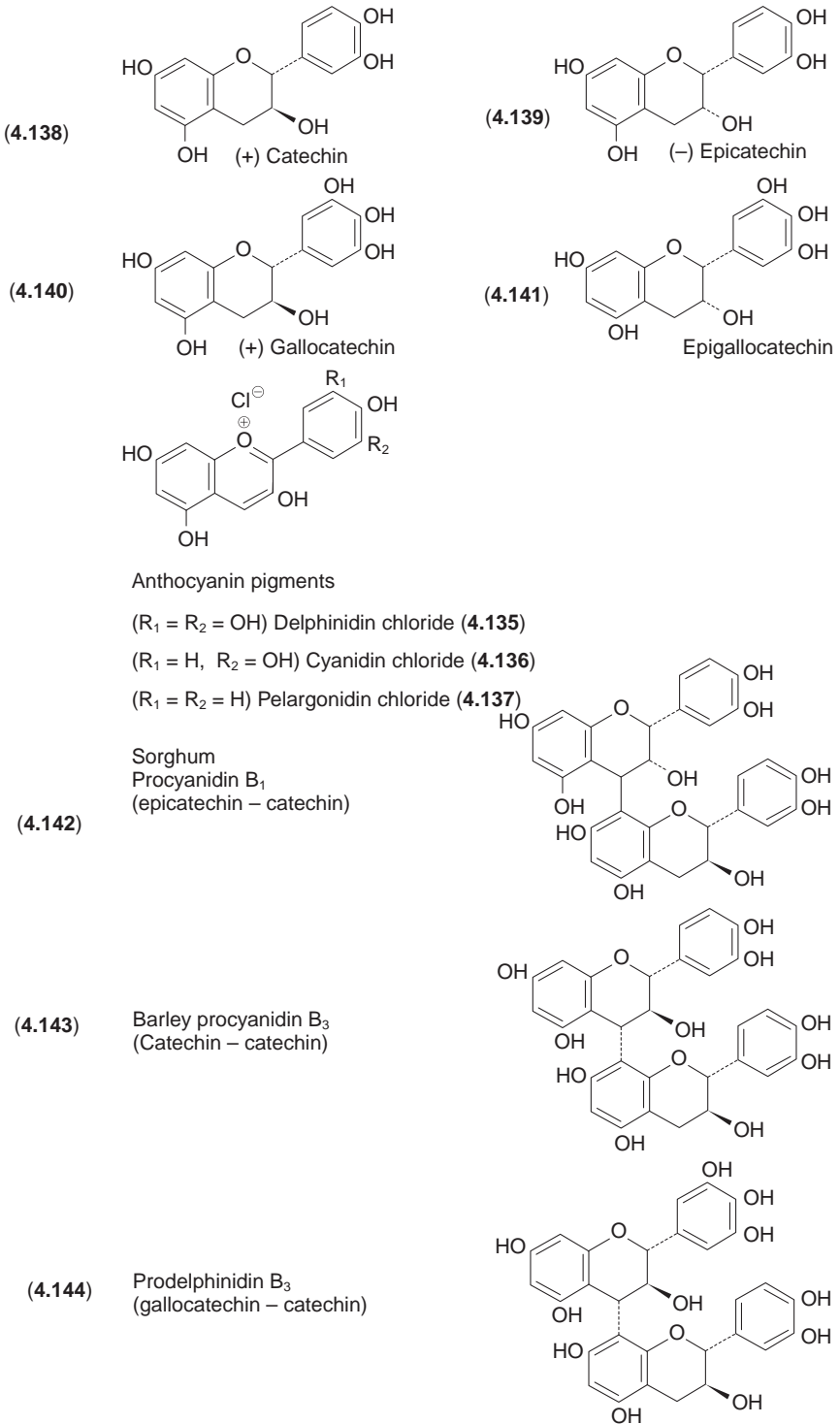
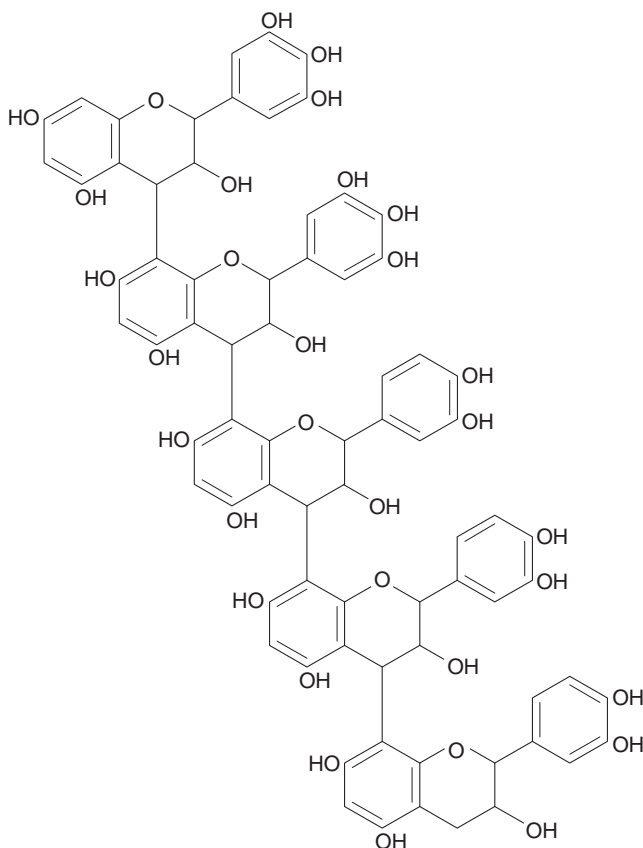

Fig. 4.34 Flavanols, including some that occur in sweet worts.



A-prodelphinidin pentamer

(4.145)

Fig. 4.35 The formula (ignoring the stereochemistry) of a pentameric proanthocyanidin (anthocyanogen) from wort (Whittle *et al.*, 1999). The composition may be represented as g-g-c-c-c, where g and c are gallic catechin (4.140) and catechin (4.138) units respectively.

number and identity of the constituent monomers the structures are complicated by differences in stereochemistry, as illustrated by the dimers procyanidin B₁ (4.142), procyanidin B₃ (4.143) and prodelphinidin B₃ (4.144). Concentrations of some flavans in barley malts are catechin (4.138) 25–75 mg/kg; prodelphinidin B₃ (4.144), 186–362 mg/kg; procyanidin B₃ (4.143), 130–276 mg/kg and 4 trimers, 336–671 mg/kg. (McMurrough and Delcour, 1994).

Malt polyphenols are partly dissolved and partly destroyed during mashing with pale malts chiefly, it is thought, by oxidative reactions mostly catalysed by peroxidase, perhaps with contributions from catalase and polyphenol oxidase. The nature of the phenolic material in wort is influenced strongly by how strongly the malt has been kilned, the availability of oxygen during mashing and the mashing programme. Mashing or sparging at elevated temperatures extracts more polyphenol into wort. Polyphenols are largely destroyed in experimental mashes made with green malt, and mash aeration or additions of hydrogen peroxide are most effective at removing anthocyanogens if the

malt has been only lightly kilned. Additions of small amounts of formaldehyde to mashes reduces proanthocyanidin levels greatly, probably by linking them to proteins in the mash (Macey, 1970; Macey *et al.*, 1966). Similar results are obtained by mashing with malts prepared by steeping or re-steeping barley or washing sorghum in dilute solutions of formaldehyde (Briggs, 1998). All these treatments were tested or used to reduce proanthocyanidin levels in beers, giving them greater resistance to haze formation, but their use has been generally discontinued. During wort run-off the mixture of phenolics alters in composition and this can be of significance (Woof and Pierce, 1966). If the pH of the sparge is allowed to increase more phenols are extracted into the wort, which is undesirable.

When phenols are oxidized they polymerize and give rise to red-brown coloured substances, called phlobaphenes. Some phenols have tanning properties (that is they bind to proteins and may precipitate them), and all of them are potentially involved in beer flavour. However, reports on their significance conflict. Phenolics are credited with altering the astringency, the mouth-feel and the after-taste of beers. However, the proanthocyanidins are the major 'tannins' in malt and it is believed that tannins are responsible for astringency, yet beers made with malts from mutant barleys and hop extracts, both lacking proanthocyanidins, are said to have the same flavour as beers made from 'conventional' barleys. Also the removal of proanthocyanidins from beer by adsorption on to PVPP (insoluble polyvinyl polypyrrolidone) is reported to have little effect on flavour. Some phenols have antioxidant effects, that is, they block the oxidative reactions of other substances, at least sometimes by destroying free radical intermediates.

The significance of malt phenol's antioxidant properties in brewing is unclear. Many of the *o*-diphenols should readily oxidize to *o*-quinones (Briggs, 1998), which will readily react with many other substances. The interactions during brewing between phenolics and proteins are certainly important. Malts made from many birdproof sorghums are so rich in phenolic tannins that during mashing many of the enzymes are inhibited and conversion is insufficient. In mashes, and indeed in wort, there is a partition of proanthocyanidins between being free in solution, being bound to soluble proteins and being bound to insoluble proteins. The associations may be reversible, as in chill hazes, or may be irreversible, as in permanent hazes. More phenolics are extracted from well-modified malts during mashing because, it is supposed, less insoluble protein remains in the grist and so a smaller proportion of phenolics are bound. Hops also contribute polyphenolics to wort.

4.4.10 Miscellaneous acids

Worts contain a wide range of aliphatic acids, in addition to fatty acids (Fig. 4.30), mostly in small amounts. These include several saturated and unsaturated, low molecular weight fatty acids (C₆–C₁₀), mesaconic/laevulinic acid, pyruvic acid (4.146) α -ketoglutaric acid (4.147), fumaric acid (4.148), succinic acid (4.149), lactic acid (4.150), oxalic acid (4.151), malic acid (4.152), citric acid (4.153), kojic acid (4.154) and gluconic acid (4.155). Most of these are well-known intermediary metabolites (Fig. 4.36; MacWilliam, 1968; Moll, 1991). The significance of these substances is usually unclear, although they must contribute to the pH buffering capacity of the wort and most can probably be metabolized by yeast.

Two of these materials are of particular interest. Lactic acid ((4.150) a mixture of the D- and L-isomers) arises from the malt and the microbes on its surface. Under some conditions excessive production results in malts that give too acid mashes. Sometimes lactic acid is deliberately added to mashes (as acidified wort, or as acid malt) to reduce



Pyruvic acid

(4.146)

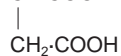

Malic acid

(4.152)

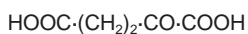

α -Ketoglutaric acid

(4.147)

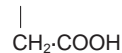
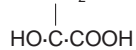
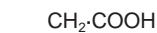

Citric acid

(4.153)

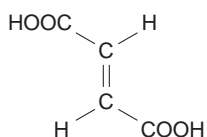

Fumaric acid

(4.148)



Succinic acid

(4.149)

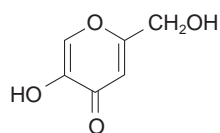

Kojic acid

(4.154)

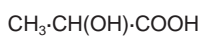

Lactic acid

(4.150)



D-Gluconic acid

(4.155)



Oxalic acid

(4.151)

Fig. 4.36 Formulae of some of the organic acids present in worts.

Table 4.23 The concentrations of some inorganic ions in various sweet worts (A, Mändl, 1974; B, Rudin, 1974; C, Moll, 1991). The all-malt worts in column A were adjusted to a concentration of 12%. The worts in column B were made with and without adjuncts

Ionic species	Concentrations (mg/litre)		
	A	B	C
Potassium, K ⁺	522	310–770	300–700
Sodium, Na ⁺	25	11–112	10–100
Calcium, Ca ²⁺	39	40–62	40–100
Magnesium, Mg ²⁺	130	–	100–150
Copper, Cu ²⁺	0.08	0.12–0.13	0.1–0.2
Iron, Fe ³⁺ (ferric)	0.08	0.23–0.37	0.1–0.3
Manganese, Mn ²⁺ (manganous)	0.13	–	0.1–0.2
Zinc, Zn ²⁺	0.12	0.07–0.16	0.1–0.3

the mash pH in a controlled fashion. Worts also contain oxalic acid (**4.151**). This, the simplest dicarboxylic acid, has a strong affinity for calcium ions and readily forms crystalline precipitates of calcium oxalate. If formed late in the brewing process this can give rise to oxalate haze and the crystals can form nuclei for the release of carbon dioxide, so potentiating gushing (over-foaming) in beer. During fermentation calcium oxalate can be deposited on the walls of the fermentation vessel as beer stone. Malted barleys can contain 5.6–22.8 mg oxalic acid/100 g dry matter while for malted wheats the values may be 22.1–50.3 mg/100 g (Narziss *et al.*, 1986). Presumably much of this is precipitated in the mash when the liquor contains a sufficient concentration of calcium ions. Since oxalate is potentially toxic it is desirable to reduce its concentration to a low level.

4.4.11 Inorganic ions in sweet wort

Some 1.5–2.0% of wort solids are materials which, after evaporation and combustion, remain in the ash. Of these the inorganic ions originate in the brewing liquor (Chapter 3) and in the grist materials, both the malt (around 2–3% ash) and the adjuncts (1–3% ash). Small amounts of ions (copper, iron, nickel, tin, zinc, etc.) may be picked up from the brewing plant. Later contributions may come from the copper adjuncts and hops. The proportions of the most important ions vary (Table 4.23). Sulphur may be present as sulphate (200–400 mg/litre), in amounts that vary widely with the nature of the brewing liquor. Sulphur also occurs in organic combinations in the amino acids methionine (**4.41**), cysteine (**4.31**) and cystine (**4.32**), the tri-peptide glutathione (γ -glutamyl-cysteinyl-glycine), coenzyme A, mercaptans, as well as hydrogen sulphide and sulphite ions. Chloride ions (40–500 mg/litre) and phosphate ions (500–900 mg/litre) also occur (Briggs, 1998; Lee, 1990; MacWilliam, 1968; Moll, 1991).

Little phosphate comes from the brewing liquor, except where phosphoric acid or acid phosphate salts have been used for pH adjustment. Most comes from the grist and may originate from nucleic acids, nucleotides, phospholipids (Fig. 4.31), and especially *myo*-inositol hexaphosphate (phytic acid, **4.156**), of which there may be 0.6–0.9% in the dry malt (Lee, 1990). Phytic acid is a strong chelating agent, and binds copper, iron and zinc ions as well as calcium ions. This material undergoes some hydrolysis during mashing, inorganic phosphate being removed sequentially from successively lower phosphate esters until free *myo*-inositol (**4.91**) is released. The extent of phytate hydrolysis is dependent on the level of the enzyme (or enzymes) with phytase activity remaining in the

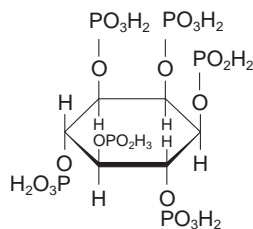
Phytic acid, *myo*-inositol hexaphosphate

(4.156)

Table 4.24 The ionic compositions (mg/litre) of a brewing water, a sweet wort made with it and the beer (Rudin, 1974)

Liquid	Ca ²⁺	Mg ²⁺	Na ⁺	K ⁺	Cl ⁻	SO ₄ ²⁻	PO ₄ ³⁻	HCO ₃ ²⁻
Brewing liquor	169	36	55	6	247	205	–	165
Wort (12°Plato)	165	127	101	550	450	338	846	–
Beer (12°Plato, original gravity)	168	113	110	440	420	330	520	–

malt after kilning and the temperature programme used in mashing. Lightly kilned malts may contain about a quarter of the enzyme originally present, while ale malts may contain little active enzyme. The pH optimum of the enzyme is about 5, and the optimum temperature is 45–50 °C (113–122 °F). The interactions between phosphates and calcium ions contribute to the desirable fall in pH which occurs during mashing (Chapter 3). Usually about two-thirds of the phosphate in sweet wort is inorganic phosphate.

It seems that usually wort provides all the necessary inorganic ions that yeast requires for sound fermentations, with the occasional exception of zinc (Donhauser, 1986; Jacobsen, 1986; Lie *et al.*, 1980). Because not all the ash components are extracted during mashing the ionic composition of the sweet wort is not the simple sum of the ions initially present in the grist and the mashing liquor (Table 4.24). Less than 5% of the zinc (or copper or iron) present in the grist is dissolved during mashing, and the proportions dissolved can be very variable. Of the zinc present in the wort only a proportion is available to yeast, presumably because the remainder is chelated or otherwise bound to other substances. Consequently simple analyses of wort zinc contents are unreliable for predicting zinc deficiency. Probably a 12% wort should contain at least 0.08 and preferably 0.1–0.2 mg Zn/litre to ensure a good fermentation. Where permitted, traces of a soluble zinc salt may be added to the wort. Where this is not permitted the use of well-modified malts and carefully acidified mashes reduce problems of zinc deficiency, as does the use of mashing equipment with metal components from which traces of zinc can dissolve.

4.5 Mashing and beer flavour

Malts and other components of the grist influence beer flavour. However, the relationships are extremely complicated. During mashing flavoured substances are extracted into the wort. Some will be destroyed or partly or wholly lost during the hop-boil, while other ‘flavour precursors’ will be converted into flavoursome substances, and others will reach the fermenter unchanged. The yeast may then metabolize many of these

substances altering their flavours. Some malt flavour substances, such as vanillin and β -phenyl ethanol, partly occur combined as β -glycosides. During mashing they can be released by hydrolysis, catalysed by β -glucosidase. In addition, oxidative changes occurring to the lipids during mashing can give rise to precursors of staling flavours. The 'redox state' of the beer has an influence on the rate of flavour deterioration and haze formation (Bamforth *et al.*, 1993, 1997; Briggs, 1998; Moir, 1989; Van Den Berg and Van Eerde, 1982). It can be advantageous to exclude oxygen from the mash and subsequently, during the production of hopped wort.

Higher levels of 'anti-oxidant' substances in the beer retard deterioration processes. These agents, which originate in the grist, seem to work in different ways. They compete for oxygen by being oxidized themselves, or they inhibit enzymes catalysing oxidations, and/or they 'scavenge' free radicals. Anti-oxidants include sulphite and bisulphite ions, polyphenols and reductones, which are ene-diol substances resembling ascorbic acid (4.96), which are formed during Maillard reactions. These compounds are found in dark malts, which have long been known to have flavour-stabilizing properties. Many hundreds of potentially active flavour substances are derived from malts or adjuncts and include aldehydes, ketones, amines, thiols and other sulphur-containing substances, heterocyclic oxygen-, nitrogen- and sulphur-containing substances and phenols. Sparging may extract unwanted flavours. Moderating sparge temperatures, for example up to 75 °C (167 °F), and keeping the pH low, e.g., to 5.5, improves beer flavour and stability.

A substance that has attracted particular interest is dimethyl sulphide (DMS, (4.158) Fig. 4.37; Dickenson, 1983). In some European lagers appreciable levels of this substance are desirable while in some other beers its absence is preferred. The precursor of this highly volatile material is S-methyl methionine (SMM, 4.157), a sulphonium compound formed by the metabolic methylation of methionine (4.41) in the malt. This substance is heat labile and so will only survive in malt if this is lightly kilned. Some is decomposed to DMS and homoserine (4.159) and the DMS produced is mostly lost with the kilning air. Some is oxidized to the less volatile dimethyl sulphoxide (DMSO, 4.160). More SMM is decomposed during the hop-boil. Surviving DMS, SMM and small amounts of DMSO reach the fermenter. Yeast may reduce the DMSO to DMS. Thus the level of DMS present in a beer depends on the malt used and the details of the production process.

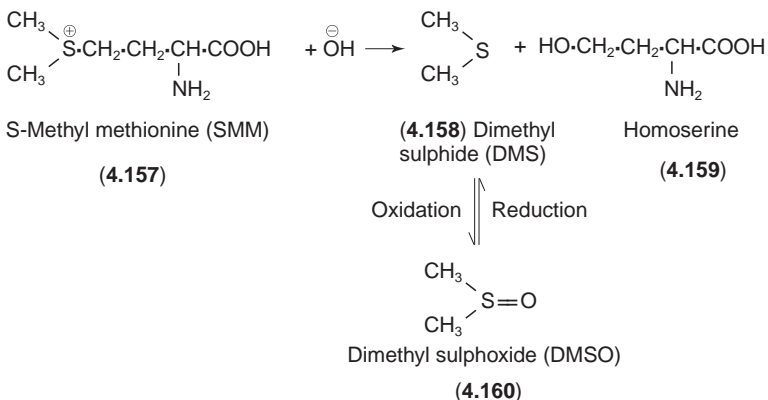

Fig. 4.37 The formation of dimethylsulphide ((4.122), DMS) from S-methyl methionine ((4.121), SMM, the DMS precursor, DMS-P) and the interconversions of DMS and dimethylsulphoxide ((4.123), DMSO).

4.6 Spent grains

At the end of every mash a brewer has a load of spent grains or draff, which must be disposed of. Of the original grist some 17–22% of the original dry matter remains, about 18–20 kg fresh weight/hl beer produced. This material is wet and, depending on the mashing system employed, contains up to 80% water. Liquid from this wet material is turbid and represents an effluent that, because of its high BOD, is costly to dispose of if directed to drain (Chapter 3). Obtaining representative samples of the spent grains is difficult, because of inhomogeneities in the filter bed, but they should be investigated to evaluate the mashing process. It is desirable to determine their content of residual extract (which is inversely related to extract recovery in the wort), and residual starch which, ideally, would have been converted during mashing. In addition inspection of the solids shows how well milling has been carried out and to what extent husk material has remained intact. The wet grains may be squeezed to remove some liquor (minimizing drainage and handling problems) and the squeezed draff may be dried with hot air. Drying is unusual as it is costly (Chapter 3). Often the squeeze liquor is returned, with or without treatment, to the process stream to recover the extract.

The composition of the spent grains depends on the grist used, the mashing programme and the recovery of the extract (Table 4.25). Relative to the malt, spent grains are enriched in protein, fibre, ash and lipid. Their major use is as a valuable feed for ruminants. They may be fed directly or after ensilage. As they deteriorate rapidly draff should be removed from the brewery as quickly as possible, to prevent their becoming a source of undesirable organisms. It has been suggested that they should be treated with a preservative, such as propionic acid, to minimize decomposition. Other actual or proposed uses for spent grains are inclusion in mushroom compost, and use as a substrate for the cultivation micro-organisms, for example filamentous fungi for feeding pigs. The draff might be fed to the pigs directly, after the mechanical removal of the fibre. After composting the spent grains might be used for turf management or as a horticultural soil conditioner. It has also been proposed that the grains be digested with enzyme preparations to produce extra 'wort' to use in the brewery or as a culture medium for other microbes.

Table 4.25 The composition and nutritive value (for sheep) ranges of brewers' wet spent grains (Briggs *et al.*, 1981). The values in parentheses are the digestible amounts. Metabolizable energy = digestible energy \times 0.81

	Mean	Range
Dry matter (%)	26.3	24.4–30.0
Crude protein (%)	23.4(18.5)	18.4–26.2(13.9–21.3)
Crude fibre (%)	17.6(7.9)	15.5–20.4(6.6–10.2)
Ether extract (%)	7.7(7.7)	6.1–9.9(5.6–9.2)
Total ash (%)	4.1	3.6–4.5
Digestible energy (MJ/kg dry wt.)	13.8	13.0–14.8
Gross energy (MJ/kg dry wt.)	21.4	21.1–21.8
DOMD* <i>in vivo</i> (%)	59.4	55.2–64.3
DOMD* <i>in vitro</i> (%)	48.6	44.8–51.5

* DOMD = Digestibility of organic matter (dry).

4.7 References

- ALBINI, P. A., BRIGGS, D. E. and WADESON, A. (1987) *J. Inst. Brewing*, **93**, 97.
- ALLEN, W. G. (1987) *Brewer's Digest*, **62** (3), 18.
- ANDERSON, I. W. (1993) *Proc. 24th Congr. Eur. Brew. Conv., Oslo*, 193.
- ANNES, B. J. (1984) *J. Inst. Brewing*, **90**, 315.
- ANNES, B. J. and REED, R. J. R. (1985) *J. Inst. Brewing*, **91**, 82, 313.
- BAJOMO, M. F. and YOUNG, T. W. (1993) *J. Inst. Brewing*, **99**, 153.
- BAMFORTH, C. W., MULLER, R. E. and WALKER, M. D. (1993) *J. Amer. Soc. Brew. Chem.*, **51**, 79.
- BAMFORTH, C. W., MOORE, J., MCKILLOP, D., WILLIAMSON, G. and KROON, P. A. (1997) *Proc. 26th Congr. Eur. Brew. Conv., Maastricht*, 75.
- BARRETT, J., CLAPPERTON, J. F., DIVERS, D. M. and RENNIE, H. (1973) *J. Inst. Brewing*, **79**, 407.
- BARRETT, J., BATHGATE, G. N. and CLAPPERTON, J. F. (1975) *J. Inst. Brewing*, **81**, 31.
- BATHGATE, G. N. (1974) *Eur. Brew. Conv. Monograph-I. E. B. C.-Wortsymposium, Zeist*, 198.
- BATHGATE, G. N. and DALGLEISH, C. E. (1975) *Proc. Amer. Soc. Brew. Chem.*, **33**, 32.
- BATHGATE, G. N. and PALMER, G. H. (1972) *Die Stärke*, **24** (10), 336.
- BOURNE, D. T. (1998) *Proc. 5th Aviemore Conf. Malting, Brewing and Distilling*. (Campbell, I. ed.). London, The Inst. of Brewing, p. 237.
- BOURNE, D. T. and WHEELER, R. E. (1982) *J. Inst. Brewing*, **88**, 324.
- BOURNE, D. T. and WHEELER, R. E. (1984) *J. Inst. Brewing*, **90**, 306.
- BOURNE, D. T., POWLESLAND, T. and WHEELER, R. E. (1982) *J. Inst. Brewing*, **88**, 371.
- BRENNER, M. W. (1972) *M. M. B. A. Tech. Quart.*, **9**, 12.
- BRIGGS, D. E. (1978) *Barley*. London. Chapman and Hall, 612 pp.
- BRIGGS, D. E. (1992) in *Barley: genetics, biochemistry, molecular biology, and biotechnology*. (Shewry, P. R. ed.) p. 361. Wallingford. C.A.B. International.
- BRIGGS, D. E. (1998) *Malts and Malting*. London. Blackie Academic, 796 pp.
- BRIGGS, D. E., HOUGH, J. S., STEVENS, R. and YOUNG, T. W. (1981) *Malting and Brewing Science* (2nd edn), Vol. 1. *Malt & Sweet Wort*. London, Chapman and Hall, 387 pp.
- BRYCE, J. H., KIM, N. J., ZAMMIT, R., MCCAFFERTY, C. A., PINHEIRO, M. G. M. and KENDALL, G. L. (1995) *Proc. 25th Congr. Eur. Brew. Conv., Brussels*, p. 285.
- BRYCE, J. H., COOPER, D. and STEWART, G. G. (1997) *Proc. 26th Congr. Eur. Brew. Conv., Maastricht*, p. 357.
- BÜHLER, T. N., MCKECHNIE, M. F. and WAKEMAN, R. J. (1996) *Food and Bioproducts Processing*, **74** (no. C4), 207.
- BURGER, W. C. and SCHROEDER, R. L. (1976) *J. Amer. Soc. Brew. Chem.*, **34**, 133; 138.
- BUTTIMER, E. T. and BRIGGS, D. E. (2000) *J. Inst. Brewing*, **106**, 71, 83.
- BUTTON, A. H. and PALMER, J. R. (1974) *J. Inst. Brewing*, **80**, 206.
- COMRIE, A. A. D. (1967) *J. Inst. Brewing* **74**, 335.
- COULTATE, T. P. (2002) *Food: the chemistry of its components*. Cambridge. The Royal Society of Chemistry, 432 pp.
- CRABB, D. and BATHGATE, G. N. (1973) *J. Inst. Brewing*, **79**, 519.
- DEBYSER, W., DERDELINCKX, G. and DELCOUR, J. A. (1997a) *J. Cereal Sci.*, **26**, 67.
- DEBYSER, W., DERDELINCKX, G. and DELCOUR, J. A. (1997b) *J. Amer. Soc. Brew. Chem.*, **55**, 153.
- DE CLERCK (1957) *A Textbook of Brewing, Vol. 1*. (Transl. Barton-wright, K.) London, Chapman and Hall, p. 587.
- DEMUYAKAR, B., OHTA, Y., NAKATANI, K., FUKUI, N. and KANAGAWA, K. (1994) *J. Amer. Soc. Brew. Chem.*, **52**, 111.
- DICKENSON, C. J. (1983) *J. Inst. Brewing*, **89**, 41.
- DIXON, M. and WEBB, E. (1958) *Enzymes*. London. Longmans, Green & Co., 784 pp.
- DONHAUSER, S. (1986) *Eur. Brew. Conv. Monograph-XI. E. B. C. – Symposium on Wort Production, Maffliers*, p. 176.
- ELIASSON, A.-C. and TATHAM, A. (2001) in *Cereals and Cereal Products – Chemistry and Technology*. (Dendy, D. A. V. and Dobraszczyk, B. J. eds) Gaithersburg. Aspen Publishers, p. 68.
- ENARI, T. M. (1974) *Eur. Brew. Conv. Monograph-I. E. B. C.-Wortsymposium, Zeist*, p. 73.
- ENARI, T. M. (1986) *Cerevisia*, **11** (1), 19.
- ENARI, T. M., MIKOLA, J. and LINKO, M. (1964) *J. Inst. Brewing*, **70**, 405.
- ENEVOLDSEN, B. S. (1974) *Eur. Brew. Conv. Monograph-I. E.B.C.-Wortsymposium, Zeist*, p. 158.
- ENEVOLDSEN, B. S. (1975) *Proc. 15th Congr. Eur. Brew. Conv., Nice*, p. 683.
- ENGAN, S. (1981) *Brewing Science, Vol. 2* (Pollock, J. R. A. ed.). London, Academic Press, p. 93.
- EVANS, E., MA, Y., EGLINTON, J., LANGRIDGE, P., LOGUE, S. and BARR, A. (2002) *Proc. Congr. Inst. Brew. (Asia Pacific Sect.)*, Adelaide, CD No. 12.
- FINCHER, G. B. (1992) in *Barley: Genetics, Biochemistry, Molecular Biology and Biotechnology* (Shewry, P. R., ed.). Wallingford. C. A. B.-International, p. 413.
- FORAGE, A. J. and LETTERS, R. (1986) *Proc. 19th Conv. Inst. Brewing (Australia and New Zealand Sect.)*, Hobart, p. 79.

- FORCH, M. and RUNKEL, U.-D. (1974) *Eur. Brew. Conv. Monograph-I. E. B. C.-Wortsymposium*, Zeist, p.269.
- FORREST, I. S., DICKSON, J. E. and SEATON, J. C. (1985) *Proc. 20th Congr. Eur. Brew. Conv., Helsinki*, p.363.
- GARDNER, H. W. (1988) in *Advanc. Cereal Sci. and Technol.* IX (Pomeranz, Y. ed.) St. Paul. A. A. C. C. p. 161.
- GEIGER, K. (1972) *M. B. A. A. Tech. Quart.* **9**, 195.
- GIERTSEN, P. and HARTLEV, P. (1980) *Eur. Brew. Conv. Monograph-VI. E. B. C.-Symposium on the relationship between malt and beer*, Helsinki, p. 186.
- HALFORD, M. H. and BLAKE, G. G. (1972) *Proc. 12th Conf. Inst. Brewing (Australia and New Zealand Sect.)*, Perth, p. 85.
- HALL, R. D., HARRIS, G. and MACWILLIAM, I. C. (1956) *J. Inst. Brewing*, **62**, 232.
- HALLGREN, L. (1995) in *Sorghum and Millets; Chemistry and Technology*. (Dendy, D. A. V. ed.). St. Paul. A. A. C. C., p.283.
- HAN, J. Y. and SCHWARZ, P. B. (1996) *J. Amer. Soc. Brew. Chem.*, **54**, 216.
- HARRIS, G. and MACWILLIAM, I. C. (1961) *J. Inst. Brewing*, **67**, 144, 154.
- HIND, H. L. (1950) *Brewing Science and Practice Vol II. Brewing Processes*. London. Chapman and Hall, pp. 507–1020.
- HOME, S., PIETILÄ, K. and SJÖHOLM, K. (1993) *J. Amer. Soc. Brew. Chem.*, **51**, 108.
- HOME, S., LAUREN, A. and AUTIO, K. (1994) *Proc. 23rd Conf. Inst. Brewing. (Asia Pacific Sect.)*, Sydney, p. 52.
- HOPKINS, R. H. and KRAUSE, B. (1947) *Biochemistry Applied to Malting and Brewing*. London. Allen & Unwin, 342 pp.
- HUDSON, J. R. (1975) *Eur. Brew. Conv. Monograph-II. E. B. C. Barley and Malting Symposium*, Zeist, p.271.
- HUG, H. and PFENNINGER, H. B. (1979) *Proc. 17th Congr. Eur. Brew. Conv., Berlin (West)*, p.355.
- HUITE, N. J. and WESTERMANN, D. H. (1974) *Proc. 14th Conv. Inst. Brewing (Australia and New Zealand Sect.)*, Brisbane, p. 133.
- HUMBERSTONE, F. J. and BRIGGS, D. E. (1998) *Proc. 5th Aviemore Conf. Malting, Brewing and Distilling* (Campbell, I. ed.) London. The Institute of Brewing, p.246.
- IMBERTY, A., BULEON, A. and VINH TRAN (1991) *Stärke*, **43** (10), 375.
- ISHERWOOD, N. D., KIRBY, W., WHEELER, R. E. and JONES, M. (1977) *Proc. 16th Congr. Eur. Brew. Conv., Amsterdam*, p.457.
- JACOBSEN, T. (1986) *Eur. Brew. Conv. Monograph-XI. E. B. C.-Symposium on Wort Production, Maffliers*. p. 196.
- JONES, M. (1974) *Eur. Brew. Conv. Monograph-I. E. B. C.-Wortsymposium*, Zeist, p. 94.
- JONES, M. and PIERCE, J. (1967) *J. Inst. Brewing*, **73**, 342.
- KIENINGER, H. (1969) *Proc. 12th Congr. Eur. Brew. Conv., Interlaken*, p. 139.
- KIENINGER, H. (1972) *Brauwelt*, **112**, 1535; 1793.
- KOBAYASHI, N., KANEDA, H., KANO, Y. and KOSHINO, S. (1993) *Proc. 24th Congr. Eur. Brew. Conv., Oslo*, p. 405.
- KROTTENTHALER, M., ZÜRCHER, J., SCHNEIDER, J., BACK, W. and WEISSER, H. (1999) *Proc. 27th Congr. Eur. Brew. Conv., Cannes*, p. 603.
- KUNZE, W. (1996) *Technology Brewing and Malting*. (Wainwright, T. transl.). Berlin. VLB, pp. 726.
- LAING, H. and TAYLOR, D. G. (1984) *Proc. 18th Conv. Inst. Brewing (Australia and New Zealand Sect.)*, Adelaide, p. 109.
- LEE, W. J. (1990) *J. Amer. Soc. Brew. Chem.*, **48**, 62.
- LETTERS, R. (1992) *Ferment*, **5**, 268.
- LETTERS, R. (1994) *Proc. 4th Aviemore Conf. Malting, Brewing and Distilling*. (Campbell, I. and Priest, F. G. eds). London, the Inst. of Brewing, p. 128.
- LETTERS, R. (1995a) *Proc. 5th Sci. Tech. Conv. Inst. Brewing (Central and Southern African Sect.)*, Victoria Falls, p. 115.
- LETTERS, R. (1995b) *Ferment*, **8**, 301.
- LETTERS, R., HURLEY, J. C. and HORAN, H. (1986) *Eur. Brew. Conv. Monograph-XI. E. B. C. Symposium on Wort Production, Maffliers*, p.250.
- LEWIS, M. J. and OH, S. S. (1985) *M.B.A.A. Tech. Quart.*, **22**, 108.
- LIE, S., HAGE, T. and JACOBSEN, T. (1980) *Eur. Brew. Conv. Monograph-VI. E. B. C. Symposium on the relationship between malt and beer*, Helsinki, p. 213.
- LISBJERG, S. and NIELSEN, H. (1991) *Proc. 3rd Sci. Tech. Conv. Inst. Brewing (Central and Southern African Section)*, Victoria Falls, p. 157.
- LITTLE, B. T. (1994) *Ferment*, **7**, 163.
- LUCHSINGER, W. W., ENGLISH, H. and KNEEN, E. (1958) *Proc. Ann. Mtg. Amer. Soc. Brew. Chem.*, p.40.
- LÜERS, H., KRAUSS, G., HARTMANN, O. and VOGT, H. (1934) *Wochensch. f. Brau.* **51** (46), 361.
- MACEY, A. (1970) *Proc. 11th Conv. Inst. Brewing (Australia and New Zealand sect.)*, Hobart, p. 117.
- MACEY, A., STOWELL, K. C. and WHITE, H. B. (1966) *J. Inst. Brewing*, **72**, 29.

- MACFADDEN, D. P. (1989) *Proc 2nd Sci. Tech. Conv. Inst. Brewing (Central and Southern African Sect.), Johannesburg*, p.306.
- MACGREGOR, A. W. (1990) *Proc. 3rd Aviemore Conf. On Malting, Brewing and Distilling*. (Campbell, I. ed.). London. Inst. Brewing, p.10.
- MACGREGOR, A. W. and YIN, X. S. (1990) *J. Amer. Soc. Brew. Chem.*, **48**, 82.
- MACWILLIAM, I. C. (1968) *J. Inst. Brewing*, **74**, 38.
- MACWILLIAM, I. C. (1972) *J. Inst. Brewing*, **78**, 76.
- MACWILLIAM, I. C. (1975) *J. Inst. Brewing*, **81**, 65.
- MACWILLIAM, I. C., HUDSON, J. R. and WHITEAR, A. L. (1963) *J. Inst. Brewing*, **69**, 303.
- MÄNDL, A. (1974) *Brauwiss.* **27**, 177.
- MARTIN, P. A. (1978) *Brewer's Guard.*, Aug., p.29.
- MARTIN, P. A. (1979) *J. Inst. Brewing*, **85**, 290.
- MAULE, D. R. (1986) *Eur. Brew. Conv. Monograph-XI. E. B. C.-Symposium on Wort Production, Maffliers*, p.72.
- MAULE, D. R. and CRABB, D. (1980) *Eur. Brew. Conv. Monograph-VI. E. B. C.-Symposium on the relationship between malt and beer, Helsinki*, p.169.
- McMURROUGH, I. and DELCOUR, J. A. (1994) *Ferment*, **7**, 175.
- McMURROUGH, I., ROCHE, G. P. and CLEARY, K. G. (1984) *J. Inst. Brewing*, **90**, 181.
- McMURROUGH, I., MADIGAN, D., DONNELLY, D., HURLEY, J., DOYLE, H., HENNIGAN, G. and McNULTY, N. (1996) *J. Inst. Brewing*, **102**, 327.
- MEDDINGS, P. J. and POTTER, O. E. (1971) *J. Inst. Brewing*, **77**, 246.
- MIKOLA, J., PIETILÄ, K. and ENARI, T.-M. (1972) *J. Inst. Brewing*, **78**, 384.
- MOIR, M. (1989) *Brewer's Guard.*, Sept., p.64.
- MOLL, M. (1991) *Beers and Coolers*. (Wainwright, T. transl.) Andover. Intercept, p.495.
- MOLL, M., FLAYEUX, R., VINH THAT and MARTIN, J. (1974) *Eur. Brew. Conv. Monograph-I. Wortsymposium, Zeist*, p.41.
- MOLL, M., FLAYEUX, R., MATHIEU, D. and PHAN TAN LUU, R. (1982) *J. Inst. Brewing*, **88**, 139.
- MÖLLER-HERGT, G., WACKERBAUER, K., TRESSL, R., GARBE, L.-A. and ZUFULL, C. (1999) *Proc. 27th Congr. Eur. Brew. Conv., Cannes*, p.123.
- MORRAYE, C. (1938) *Pet. J. Brasseur.*, **46**, 464.
- MORRISON, W. R. (1978) in *Advanc. Cereal Sci. and Technol. II* (Pomeranz, Y. ed.) p.221.
- MORRISON, W. R. (1988) *J. Cereal Sci.*, **8**, 1.
- MULLER, R. F. (1989) *Proc. 22nd Congr. Eur. Brew. Conv., Zurich*, p.283.
- MULLER, R. (1991) *J. Inst. Brewing*, **97**, 85, 93.
- MULLER, R. (1995) *J. Amer. Soc. Brew. Chem.*, **53**, 53.
- MUTS, G. C. J. (1991) *Proc. 3rd Sci. Tech. Conv. Inst. Brewing, (Central & Southern African Section), Victoria Falls*, p.51.
- MUTS, G. C. J. and PESMAN, L. (1986) *Eur. Brew. Conv. Monograph-XI. E. B. C.-Symposium on Wort Production, Maffliers*, p.25.
- MUTS, G. C. J., KAKEBEEKE, M. G., PESMAN, L. C. and VAN DEN BERG, R. (1984) *Proc. 18th Conv. Inst. Brewing (Australia and New Zealand Section), Adelaide*, p.115.
- NARZISS, L. (1977) *Brauwelt*, **117** (37), 1420.
- NARZISS, L. (1978) *Proc. 15th Congr. Inst. Brewing (Australia and New Zealand Sect.), Christchurch*, p.35.
- NARZISS, L. (1991) *Brauwelt Internat.*, **4**, 284.
- NARZISS, L. (1992a) *Die Bierbrauerei*, 2 Band. *Die Technologie der Würzbereitung* (7th edn). Stuttgart. Ferdinand Enke, p.402.
- NARZISS, L. (1992b) *Brauwelt*, (23), 1072.
- NARZISS, L., REICHENEDER, E. and IWAN, H.-J. (1986) *Monatss. f. Brauwiss.*, **39**(1), 4.
- NARZISS, L., MIEDANER, H. and NITZSCHE, F. (1990) *Monatss. f. Brauwiss.*, **3**, 96.
- OLIVER-DAUMEN, B. (1988) *Brauwelt Internat.*, (III), 256, 370.
- PIERCE, J. S. (1980) *Eur. Brew. Conv. Monograph-VI. E. B. C.-Symposium on the relationship between malt and beer, Helsinki*, p.179.
- PIERCE, J. S. (1982) *J. Inst. Brewing*, **88**, 228.
- POLLOCK, J. R. A. and POOL, A. A. (1968) *Proc. Ann. Mtg. Amer. Soc. Brew. Chem.*, p.33.
- PRECHTL, C. (1967) *M. B. A. A. Tech. Quart.*, **4**, 98.
- RENNIE, H. and BALL, K. (1979) *J. Inst. Brewing*, **85**, 247.
- RUDIN, A. D. (1974) *Eur. Brew. Conv. Monograph-I. E. B. C.-Wortsymposium, Zeist*, p.239.
- SCHILD, D. (1936) *Wochenschr. Brau.*, **53**, 345, 353.
- SCHUR, F., PFENNINGER, H. B. and NARZISS, L. (1973) *Proc. 14th Congr. Eur. Brew. Conv., Salzburg*, p.149.
- SCHUR, F., PFENNINGER, H. B. and NARZISS, L. (1975) *Proc. 15th Congr. Eur. Brew. Conv., Nice*, p.191.
- SCHWARZ, P. B. and HAN, J.-Y. (1995) *J. Amer. Soc. Brew. Chem.*, **53**, 157.
- SCOTT, R. W. (1972) *J. Inst. Brewing*, **78**, 179, 411.
- SCOTT, P. M. (1996) *J. A.O.A.C. International*, **79**, 875.

- SISSONS, M. J. (1996) *J. Amer. Soc. Brew. Chem.*, **54**, 19.
- SJÖHOLM, K., MACRI, L. J. and MACGREGOR, A. W. (1995) *Proc. 25th Congr. Eur. Brew. Conv. Brussels*, p. 277.
- SOPANEN, T., TAKKINEN, P., MIKOLA, J. and ENARI, T.-M. (1980) *J. Inst. Brewing*, **86**, 211.
- STARS, A. C., SOUTH, J. B. and SMITH, N. A. (1993) *Proc. 24th Congr. Eur. Brew. Conv., Oslo*, p. 103.
- STENHOLM, K. and HOME, S. (1999) *J. Inst. Brewing*, **105**, 205.
- STENHOLM, K., HOME, S., PIETILÄ, K., MACRI, L. J. and MACGREGOR, A. W. (1996) *Proc. 24th Conv. Inst. Brewing, (Asia Pacific Section), Singapore*, p. 142.
- STONE, B. A. (1996) in *Cereal Grain Quality* (Henry, R. J. and Kettlewell, P. S. eds). London, Chapman & Hall, pp. 251, 288.
- SUN, Z. and HENSON, C. A. (1990) *Plant Physiol.*, **80**, 310.
- TAYLOR, D. G. (1981) *Brew. Distill. Internat.*, **11** (4), 35, 42.
- TAYLOR, L. (1974) *Eur. Brew. Conv. Monograph-I. E. B. C.-Wortsymposium, Zeist*, p. 208.
- TENG, J., STUBITS, M. and LIN, E. (1983) *Proc. 19th Congr. Eur. Brew. Conv., London*, p. 47.
- TESTER, R. F. (1997) in *Starch Structure and Functionality* (Frazier, P. J., Richmond, P. and Donald, A. M. eds). Cambridge. Royal Society of Chemistry, p. 163.
- VAN DEN BERG, R. and VAN EERDE, P. (1982) *Proc. 17th Conv. Inst. Brewing (Australia and New Zealand Sect.)*, Perth, p. 70.
- VOSE, J. R. (1979) *M. B. A. A. Tech. Quart.*, **16**, 186.
- WACKERBAUER, K., ZUFALL, C. and HÖLSCHER, K. (1993) *Brauwelt Internat.*, **11**, 107.
- WAINWRIGHT, T. (1980) *Eur. Brew. Conv. Monograph-I. E. B. C.-Symposium on the relationship between malt and beer, Helsinki*, p. 118.
- WALKER, M. D., BOURNE, D. T. and WENN, R. V. (1997) *Proc. 26th Congr. Eur. Brew. Conv., Maastricht*, p. 191.
- WEBSTER, R. (1978) *Brewer's Guard.*, **107** (7), 51, 56.
- WHITEAR, A. L., MAULE, D. R. and SHARPE, F. R. (1983) *Proc. 19th Congr. Eur. Brew. Conv., London*, p. 81.
- WHITTLE, N., ELDRIDGE, H., BARTLEY, J. and ORGAN, G. (1999) *J. Inst. Brewing*, **105**, 89.
- WIEG, A. J. (1987) in *Brewing Science 3* (Pollock, J. R. A., ed.). London. Academic Press, p. 533.
- WINDISCH, W., KOLBACH, P. and SCHILD, E. (1932) *Wochensch. f. Brau.*, **XLIX**, (37, 38), 289, 298.
- WOOF, J. B. and PIERCE, J. S. (1966) *J. Inst. Brewing*, **72**, 40.
- WRIGHT, H. E. (1892) *A Handybook for Brewers*. London. Crosby Lockwood, 516 pp.
- YAMADA, K. and YOSHIDA, T. (1976) *Rept. Res. Lab. Kirin Brewery Co.*, no. 19, 25.
- ZHANG, N. and JONES, B. L. (1995a) *J. Cereal Sci.*, **21**, 145.
- ZHANG, N. and JONES, B. L. (1995b) *J. Cereal Sci.*, **22**, 147.
- ZIEGLER, L. and PIENDL, A. (1976) *M. B. A. A. Tech. Quart.*, **13**, 177.

5

The preparation of grists

5.1 Intake, handling and storage of raw materials

Malts and mash tun adjuncts may be delivered by road, rail or, more rarely, water. For large breweries deliveries are in bulk, but for smaller ones deliveries may be in sacks varying in weight from about 25 kg. to 1 t. The largest sacks are handled with fork-lift trucks. Lorries generally carry loads of 20–25 t, while American railway wagons carry about 68–82 t of malt. Some small breweries receive their malt ready ground. Before a load is accepted it should be checked to ensure that it is of the correct quality. Visual inspection and rapid tests on malt should indicate that the colour, moisture content, nitrogen (protein) content, flavour, aroma, friability, homogeneity and range of corn sizes are correct and that the load is free from insects and the corns are not unduly damaged (Briggs, 1998; Kunze, 1996; Narziss, 1992; Nicol and Andrews, 1996; Rehberger and Luther, 1994; Sugden *et al.*, 1999).

Different types of malt and adjuncts must not be allowed to mix, either during handling or subsequent storage. Each load is weighed, for example, by weighing each lorry on a weighbridge before and after unloading, and during movements within the brewery. While mechanical handling can be used for malts and many adjuncts, flours must be moved using pneumatic equipment. Many different arrangements of equipment are used in dry-goods handling (Fig. 5.1). In the UK lorries usually discharge by tipping their loads into a reception pit which is sheltered from the weather and is aspirated to remove dust.

Handling is with equipment that damages the material being moved as little as possible and so causes minimal losses and generates least dust. Usually the machines used are belt and bucket elevators, and screw, drag, chain-and-flight or *en masse* conveyors (Briggs, 1998). All these should be aspirated to remove dust, which is usually collected at a central point. Initially, malt is often roughly screened (sieved) to remove coarse and fine impurities, and is passed over magnetic separators (of fixed or revolving magnet types) to remove fragments of metal. Sometimes the malt is separated from ‘heavy contaminants’ by passing it through a transverse airflow, which deflects the comparatively light malt while allowing denser objects to continue falling downward, to be collected separately. The removal of metal items (‘tramp iron’) and subsequent de-stoning are necessary to reduce wear on conveying equipment and the brewery mills and to reduce the risks of sparks which can lead to fires or explosions.

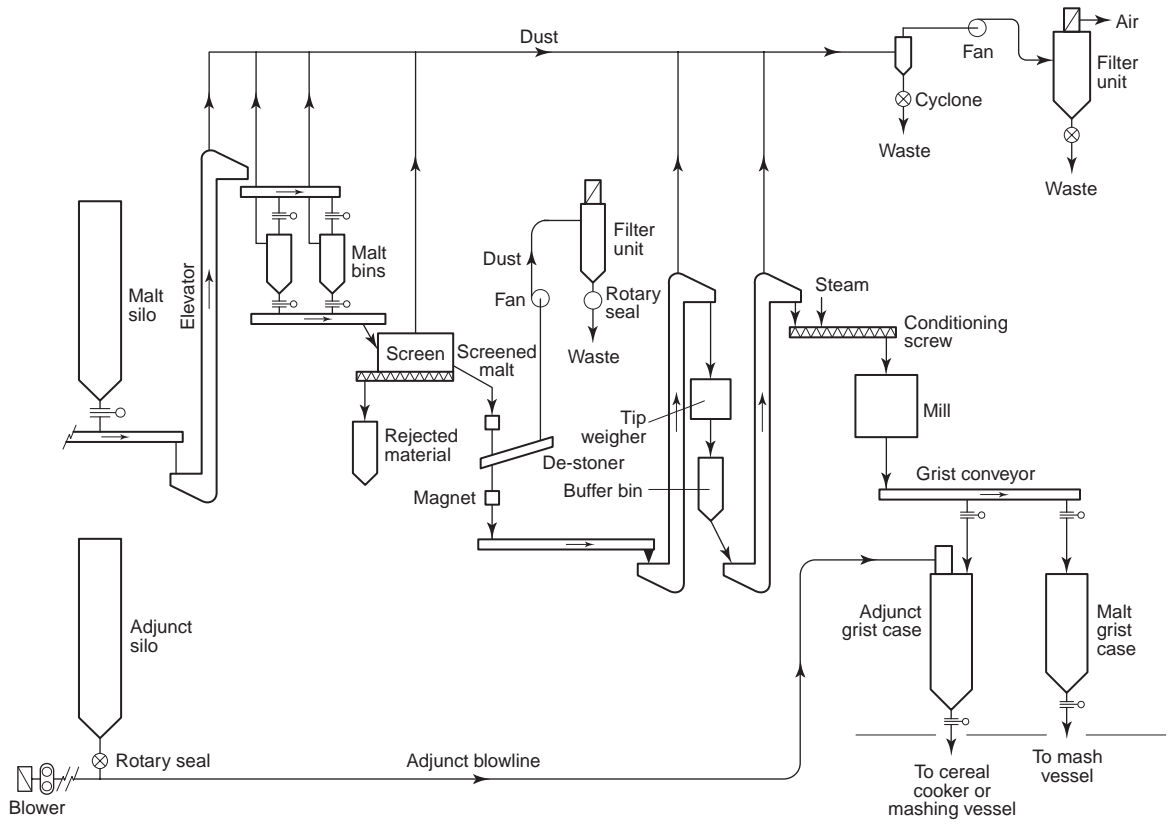

Fig. 5.1 An example of a dry goods handling system.

In British breweries malt, as now delivered, often meets such tight specifications that preliminary screening is not needed. Grist materials, and especially malts, are hygroscopic and efforts are made during handling and storage to prevent them picking up moisture by contact with water or from the air and so becoming 'slack'. Pneumatic conveyors may function on positive or negative ('suction') pressures. In positive-pressure systems a blower forces air along fixed or flexible pipework and malt or other material is introduced into the airstream from hoppers, via air-tight, rotating valves. The material is swept along and is recovered from the airstream in expansion chambers and cyclones. The material drops out from the slower airflow into a receiving hopper. Dust is separated from the air, using cyclones and textile filters, before escaping from the building. Modern filters are self-cleaning and occasional backflows of air dislodge the dust caked onto the filter sleeves, allowing it to fall into a reception hopper, from which it is removed through a valve. Negative-pressure systems work under suction so that material is sucked into the system. This is convenient for unloading rail wagons and barges and is also advantageous in that dust does not leak and escape. This type of conveyor can form part of the main dust collection system. The 'used' air passes through cyclones and dust filters before it reaches the pump that provides the suction. Some grain-cleaning equipment re-circulates air, preventing the dust escaping and collecting it in the machine.

Handling dry goods always generates dust. This is heavily infested with microbes and their spores and, mixed with air in a range of proportions, is highly explosive. It is estimated that 0.4–1.4% of malt delivered to a brewery is damaged and converted into dust. Intake hoppers, conveyors, elevators, stores, screens, de-stoners and dry mills should all be ventilated and the aspirating air directed to the dust-collection system. The dust is usually mixed with the spent grains and sold. Less usually it may be discarded or destroyed. Dust from malt and adjuncts is rich in starch and may be added into mashes. Dust, either in or around equipment such as mills and conveyors, should not be allowed to accumulate as it becomes damp and microbes and insects multiply on it. Dust must be kept away from the brewing plant as the microbes in it can initiate beer spoilage. In addition it constitutes a health risk, giving rise to skin allergies and lung infections. Dust explosions can be highly destructive and life-threatening. Rigid rules of behaviour and the use of well-designed equipment must be used to minimize the risks. Dust containment and removal are essential. Explosions may be initiated by sparks or flames and so stones and tramp iron are removed from malt and adjuncts, smoking and the use of flames (e.g. welding torches) is forbidden and all equipment is earthed or 'grounded' to discharge static electricity safely and avoid sparking. Sensors are mounted on bearings to detect increases in temperature, which indicate poor lubrication, wear and the risk of initiating a dust explosion.

Overloaded equipment is automatically closed down. Silos have dust-sealed lighting and silos and ducts are fitted with physically weak explosion relief hatches that will burst on a sudden pressure rise and will allow the explosion to vent in a comparatively safe way. This reduces the force being transmitted through the ducting and so reduces the chance of secondary explosions and other damage remote from the initial explosion site. Some pieces of equipment, such as dry mills, are fitted with devices which, when triggered, release an inert gas and quench explosion flames. The three most common sites of explosions in breweries, in decreasing order, are bucket elevators > silos > mills. As with all equipment, the dust-collection system should be inspected regularly, and be cleaned and maintained.

Malts and adjuncts are stored so that they do not become damp and 'slack' and they are protected from birds, rats, mice and insects. Storage is costly, and so it is desirable to have as small stocks as are considered prudent. In practice, breweries may carry stocks sufficient to allow from three days' to three weeks' production. In smaller or older

breweries the malts and adjuncts may be stored in sacks, traditionally in a room above the mill room. Usually malt is stored in bulk in bins or silos. These are usually of steel or concrete, with smooth internal surfaces with conical bases having a valve at the bottom to allow metered unloading, under gravity, into a conveyor. Different materials have different angles of repose and they need different valley angles in the tapered or conical bases to allow them to flow freely (see Appendix).

There is a tendency for flowing, granular material to segregate by size and density. To avoid this stores should be unloaded using 'bulk flow' systems that avoid funnel flow. This can be achieved using suitable vessel designs (Farnish, 2002). Flour is often slow to flow, and it may be necessary to have a vibrating cone or a mechanical device (such as an arch-breaker) in the cone to encourage movement. Silos are loaded by conveyor from above and are equipped with hatches and manways to allow inspections and cleaning. Level-detecting devices determine the approximate levels of the contents and prevent over-filling. They should contain thermometers to detect any temperature rises that give warning of the onset of spoilage. It is good practice to use old stocks first and never to mix old and new stocks. Each storage container should be completely emptied in turn, and be cleaned and, if necessary, fumigated before being refilled. If grist materials must be treated to control insects this must be done using only fully trained staff, using an approved insecticide or fumigant at a permitted dose rate.

Batches of malts or adjuncts and grists are weighed as they are moved around in the store, or to or from the mills. The records of the weighings are used to check on losses, that the correct mixtures of materials enter each mash, and that the yield of extract from each mash is acceptable. Electronic and mechanical weighers and load cells are in use and some are capable of high degrees of accuracy. In many weighers the malt, or other material, flows from above into a weighing container. When the chosen weight is approached the flow-rate is reduced and as the weight is reached the flow is stopped. The weighing container then empties from the base into a receiving buffer hopper. When it is empty the base closes and refilling is resumed. Weighing is recorded as the number of fillings that have taken place. Sometimes hoppers and other containers, such as grist cases, are mounted on load cells, which indicate the weight of the contents. Load cells can be mounted under conveyors to measure the weight of material continuously as it is being conveyed. While older weighers were perhaps accurate to $\pm 2\%$ new machines, using load cells, can be good to $\pm 0.1\%$.

Before the grist materials reach the mill they may be screened again, removing all items larger or smaller than malt corns. They will pass over a magnetic separator and they should pass through a de-stoner and/or a 'heavy object separator' and be aspirated. In de-stoners a thin stream of malt flows slowly onto the upper end of an inclined screen. Air passes up through the screen at such a rate that the malt 'floats' and flows downwards, being collected at the base. Heavier objects, such as stones, are not lifted and rest on the screen. This has a jerking motion that moves the stones up the screen and over the upper edge into a collector (Briggs, 1998).

When mixtures of different grist materials are to be used they must be moved to the mills and the grist case, bypassing the mill in some cases (as when wheat flour is used), in the correct proportions and at the correct rates so that the correct grist, well mixed, is supplied when mashing in occurs. 'Dry goods handling' is controlled from a central point, where the states of the stores, whether equipment is running and the states of processes are monitored and controlled often with a mimic display or, increasingly, through a computer. Each system has built-in safety and warning devices (Bhaduri, 1996). For example, when the flow of malt from a silo to the mill is switched off the valves, conveyors, elevators, etc., are switched off in sequence, beginning at the silo, so each unit is emptied of malt before it stops running.

Start up is in the reverse order. For safety and effective operation all the staff must be well trained. Checking and maintenance of the equipment must be carried out regularly. Safety is also dependent on the layout of the plant and this and the way it is operated must meet high design standards and local regulations.

5.2 The principles of milling

The objective of milling is to break up malt and adjuncts to such an extent that the greatest yield of extract is produced in the shortest time in the mashing equipment in use. With most wort separation systems it is desirable to keep malt husk as intact as possible, to help maintain an open filter bed that favours wort separation. No unbroken grains should survive milling. Only comparatively coarse grists can be used in mash tuns. If the grist is too fine (has too high a proportion of small particles) the wort will not separate from the spent grains. Finer grists can be used in lauter tuns and still finer grists in mash filters. A 'best practical' grist, with an optimal mixture of coarse, fine and very fine particles, is determined for each mashing system. Optimal milling is not simple to achieve. Mill settings need to be altered for adjuncts or malts differing in their degrees of modification (badly modified malts should be milled to a finer grist, well modified malts readily shatter), and quite small differences in moisture contents alter the effectiveness of milling using one mill setting (Crescenzi, 1987). Sometimes different mills are used for malt and for adjuncts, or for pale malts and coloured malts. In other cases adjuncts, such as torried barley or wheat, flaked cereals, and roasted barley, may be milled mixed with the malt(s).

The term 'grinding', for milling, comes from the days when malt was ground between millstones, and the ground material is still termed 'grist'. This should be distinguished from grain particles, present in grists, which are termed 'grits'. Milling systems may use roller milling, impact milling with disc- or hammer-mills, and wet milling. Properly, none of these modern mills 'grinds' the malt. Roller milling (dry or conditioned), giving comparatively dry grists, is the most usual. These grists are evaluated by inspection, by sieve analyses and sometimes in laboratory mashes. A grist should be uniform in appearance, be free from taints and insects or other contaminants and should not contain any whole grains or large grain pieces that indicate that part of the grist has not been effectively milled.

Sieve analyses should be used regularly to check that a mill's performance is not drifting. The most commonly used sets of sieves are the Pfungstadt plansifter (EBC), the MEBAK sieves and the sieves of the ASBC (Table 5.1). A sample of grist is loaded onto the top of a set of horizontal sieves, which is shaken mechanically for a fixed period of time. The percentage, by weight, of the grist retained on each, successively finer sieve is then determined. By convention the sieve fractions are given names (Table 5.1), but the fractions are not 'pure' so, for example, the 'husk' fraction contains tissues from the rest of the malt grains and husk tissue occurs in the other fractions. Furthermore, the grist fractions from a malt milled in different ways are likely to have different compositions. The results in Table 5.2 show that starch is present in the 'husk' fractions proving contamination with endosperm material while the distribution of fibre in all the fractions suggests that at least traces of husk occur in all of them. The variable extract yields and qualities obtained when different fractions of a grist are mashed has often been noticed (Hind, 1950; Narziss, 1992; Stubits *et al.*, 1986; Table 5.3). It has been suggested that different beers could be produced by combining the fractions in different proportions in the mash (e.g. Isoe *et al.*, 1991), or that beers should be made with husk-depleted grists or

Table 5.1 Details of the sieves used to characterize grists. The names given to the fractions do NOT indicate that these are morphologically pure grain fractions. The composition of the fractions changes with the type of milling employed. The American Society of Brewing Chemists (ASBC) and the European Brewery Convention (EBC) (Pfungstadt) sieves are significantly different and the MEBAK sieves are different again (see footnote). All dimensions are in millimetres

Sieve number	ASBC		EBC			
	Mesh width (mm)	Fraction name	Sieve (Pfungstadt) number	Wire thickness (mm)	Mesh width (mm)	Fraction name
10	2.000	Husk	1 (16)	0.31	1.270	Husk
14	1.410	Husk	2 (20)	0.26	1.010	Coarse grits
18	1.000	Husk	3 (36)	0.15	0.547	Fine grits I
30	0.590	Coarse grits	4 (85)	0.07	0.253	Fine grits II
60	0.250	Fine grits	5 (140)	0.04	0.152	Flour
100	0.149	Flour	Tray (through)	–	–	Fine flour
Pan (through)	–	Fine flour				

The MEBAK screens I, II, III, IV and V have mesh widths (mm) of 1.25, 1.00, 0.5, 0.25 and 0.125.

Table 5.2 The analyses of ASBC sieve fractions of Larker malt milled with a 5-roller Bühler-Miag malt mill (data of Stubits *et al.*, 1986). Grist samples (100 g) were mashed with a liquor/grist ratio of 3/1. The mash programme was 45 °C/67 min., then a temperature rise of 1 °C/min. to 69 °C, a hold for 35 min., then a rise to 72 °C

Sieve number	Starch (%)	Protein (%)	Fibre (%)	Wort (°P)	Viscosity (relative)
10	50.1	12.0	7.1	16.6	2.07
14	56.1	13.8	4.1	19.1	2.60
18	63.4	11.6	3.5	20.9	2.62
30	54.9	13.4	3.7	20.4	2.50
60	47.1	15.4	5.2	19.8	2.44
100	49.4	17.7	4.3	20.1	2.41
Pan	69.9	11.8	1.9	21.7	2.54

Table 5.3 Analyses of a malt grist and the Pfungstadt sieve fractions 1–6 of that grist (data of Narziss and Krauss, via Narziss, 1992)

Analyses	Entire grist	Husks (1)	Coarse grits (2)	Fine grits I (3)	Fine grits II (4)	Flour (5)	Fine flour (6)
Proportions (%)	100	27.6	15.3	22.9	13.2	6.6	14.4
Extract (%)*	80.2	64.4	79.5	87.9	84.2	83.3	96.8
Saccharification time (min.)	9	8	9	8	9	10	12
Fermentation limit (%)	80.9	77.3	78.0	82.0	82.5	80.9	83.2
Protein (%)*	11.1	12.4	11.9	10.6	11.4	13.4	7.6
TSN (mg/100 g)*	711	584	681	705	847	854	526
Viscosity (mPa.s, 8.6% wort)	1.515	1.534	1.463	1.481	1.443	1.467	1.407
DP (°W.-K)	302	225	323	361	347	327	250
α-Amylase (ASBC)	40	32	44	51	48	47	36
Tannoids (mg PVP/100 g)*	22	12	32	20	21	24	12
Colour (°EBC)	3.3	4.7	2.8	2.5	2.8	2.8	1.3

TSN, total soluble nitrogen. DP, diastatic power. PVP, polyvinyl pyrrolidone. *Dry weight basis.

Table 5.4 EBC/Pfungstadt sieve analyses (% in each fraction) of all-malt grists suitable for different mashing systems (Kunze, 1996; Narziss, 1992; Sugden *et al.*, 1999)

Sieve	Mash tun	Lauter tun		Mash filter (conventional)			Thin-bed filter	
		a	b	a	b	c	a	b
1	27	18	18–25	11	8–12	10–12	1	1
2	9	8	< 10	4	3–5	4–6	4	2
3	24	35	35	16	15–25	< 15	9	15
4	18	21	21	43	35–45	> 43	26	29
5	14	7	7	10	8–11	> 12	19	24
Tray	8	11	< 15	16	12–18	< 16	41	29

the fractions should be mashed separately in different ways, to obtain a beer with a ‘refined’ flavour (Krottenthaler *et al.*, 1999). While this is technically possible this approach has been little used, probably because of the extra cost of the fractionation procedures and the problem of using or disposing of the ‘husk’ fraction.

Examples of all-malt grists regarded as being suitable for use with different mashing systems are given in Table 5.4. In moving from the mash tun grist across to the grist for the thin-bed filter the grists become finer. It is seen that there are small differences between the proposed grists. This is expected as ‘best’ grists are determined by brewers using trial and error, employing different mills and equipment. Grists prepared by wet milling are not suitable for particle size analyses. In these cases grist quality is judged indirectly by noting the appearance and performance of mashes, particularly extract yield, run-off rate, wort clarity, the appearance of the spent grains and so on. The same criteria are also applied to mashes made with dry milled grists, which are also subjected to sieve analysis.

Roll (or roller) mills are commonly used in breweries. The rollers work in pairs. The malt grains are delivered to the first pair of rolls by a feed roll that determines the feed rate and is intended to deliver each corn ‘end-on’ to the working rolls. Each corn is drawn between the rolls and is crushed, sheared (if the rolls are rotating at different speeds) and cut if the rolls are fluted (grooved). The theoretical capacity of a roll mill, Q (m^3/h), is given as $Q = 60.s.NL^{10}$, where s = rotational speed (rpm); N = the gap between the rollers or ‘nip’ (mm); L = the length of the working surfaces of the rolls (mm). In fact the practical working capacity is 10–30% of the theoretical capacity (Sugden *et al.*, 1999). Working rates of different mills (in kg/h/mm roll length) are given as two-roll mills, 1.5–2.5; four-roll mills, 2–6 and six-roll mills, 1.5–10.

The action of crushing rolls, with centres A_1 and A_2 , on a particle, centre B , is illustrated in Fig. 5.2. A component, e , of the force t tends to draw the particle between the rolls. The force t depends on the force r and the coefficient of friction between the surfaces of the particle and the roll, μ , so $t = \mu r$. The force components e and m are opposed and so unless $e > m$ the particle will not be pulled between the rolls and be crushed. Thus $\mu r \cos \alpha > r \sin \alpha$ and so $\mu > \tan \alpha$ which must, therefore, be less than the coefficient of friction. Often a typical value for α is 16° . The angle OEF, the angle of nip, equals 2α . There is a definite relationship, $\cos \alpha = \text{radius of the roll} + \text{half the gap between the rolls} / (\text{radius of the roll} + \text{radius of the particle})$. If α is 16° , then $\cos \alpha = 0.961$. If the angle of nip is too large (because the rollers are too small) and/or the rolls are rotating too quickly, particles ‘ride the rolls’, so they are not drawn between them and they are not crushed.

The peripheral roll speeds in brewery mills are often 2.4–4 metres/sec (8–13 ft./sec.). As a particle moves between the rollers so it deforms and, if it is brittle, its structure fails and it breaks up (Sugden *et al.*, 1999). Rolls may move at different speeds, for example the faster may rotate at 1.25 the speed of the slower. Consequently a particle passing between them

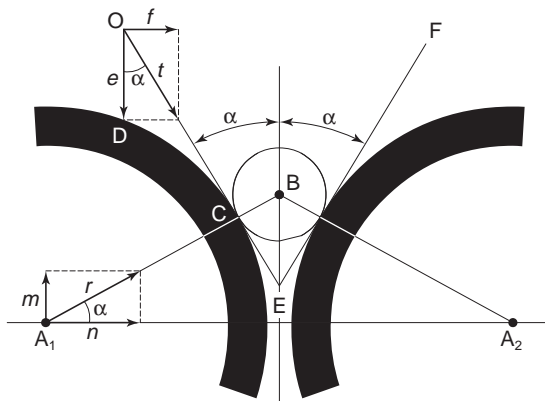

Fig. 5.2 The action of two crushing rolls, rotating at equal speeds, on a particle such as a malt corn (see the text).

will be torn by shear as well as being crushed. As well as that the grooves, or ‘fluting’ milled in spirals on the surfaces of the rollers can be arranged not only to increase the coefficient of friction between the particles and the rolls, but also to cut the particles (Kunze, 1996).

Roll mills differ in their complexity. They have to cope with materials, particularly malt corns, that differ in their ranges of widths and so the nips, the gaps between the rolls, must be adjustable. In addition corns and other materials break up to give particles of a range of sizes. Some of these, the fine grits and flour, need no more milling while larger materials can, with advantage, be broken up more. In more complex mills this is achieved by sieving the material coming from a pair of rolls on cylindrical or flat-bed screens. The fine fractions leave the mill directly while coarser fractions are directed between other pairs of rolls and are broken up further. In the cylindrical screens the grist may be disrupted by spinning ‘beaters’. In the flat-bed, oscillating screens rubber balls move about and oscillate vibrating the sieving surfaces and keeping them clear of blockages. Dry mills deliver their grist to a receiving hopper or ‘grist case’, so several hours working time may be available to prepare a batch of grist. In contrast, with ‘wet’ mills the grist is mashed in as it is produced and the mashing-in period must not be too long. Consequently wet mills operate at faster rates than dry mills.

5.3 Laboratory mills

Many kinds of mills are used in laboratories, but for standard analyses particular mills, operated in closely defined ways, are employed. This is because the analyses are used as bases of commercial transactions as well as standards by which the value of malts to a brewery can be judged and so different laboratories must obtain analytical results that are in close agreement. During the last century the ‘standard’ mills have changed. Initially hand-cranked Boby or Seck mills, each with one pair of small rolls, were used and, in time, these were powered with electric motors. These mills were not able to give sufficiently reproducible results and so, at least for fine grinds, some used cone mills. The EBC introduced a Casella mill in which the malt was shattered by the blades on a spinning rotor and the grist was collected after passing through a sieve, different sieves being used for the coarse and fine grinds. In a comparatively short time this mill was replaced by another, a Bühler-Miag disc mill, which is in use at present by both the EBC and the IGB. In this sophisticated machine the sample to be ground is fed into the central area between two

discs, one static, the other rotating fast at a fixed speed. The grist emerges from the gap at the periphery and is collected. The fineness of grind is determined by the distance between the discs, which for the IoB methods are 0.7 mm for the coarse grind and 0.2 mm for the fine grind. It is apparent that this mill differs in its method of working from almost all commercial malt mills used in brewing. This ‘disadvantage’ is more apparent than real, since the results it gives are highly reproducible and, as with every analytical system, each brewer has to establish the relationships between the laboratory analyses and the results obtained with his, possibly unique, brewing system.

5.4 Dry roller milling

A large number of types of roller mills have been, or are, in use (Kunze, 1996; Narziss, 1992; Sugden *et al.*, 1999). ‘Dry’ mills have some characteristics in common. The feed roll delivers the malt to the first pair of crushing rolls, across their full width, at a controlled rate. The rolls are designed to deliver the corns ‘end on’ to favour their being crushed along their length with the minimum degree of husk breakage. The rolls are often about 250 mm (9.84 in.) in diameter (in wet mills they are often larger). As noted the rolls are usually fluted and may run at different speeds. Both may be driven but sometimes only one is powered, the ‘follower’ being dragged by the friction between the grist and the moving, powered roll. Mill rolls may operate at 250–500 rpm. The roll length increases with machine capacity, to a maximum of about 1500 mm (59.06 in.). The rolls are spring loaded, and so the gaps between them must be checked while they are working under load. This is achieved by passing soft metal wire between the working rolls, then measuring the thickness of the squashed metal with a micrometer screw gauge. Lead wire was originally used, but now aluminium, copper or lead-free solder wires are employed, to avoid any chance of lead contamination. The roll gaps and the alignment of the rolls must be checked regularly, to ensure that they are parallel. In addition the rolls must be checked for wear. The grist coming from each section of the roll pairs must be inspected and checked by sieve analysis. This test will detect when the central portions of the rolls are badly worn but the end regions are not. Where screens are used these too must be checked for integrity. After use the mills should be cleaned. At no time should insect infestations be present.

The simplest mills are single-pass, two-roll dry mills. These are relatively slow working and are inflexible, being suitable only for well-modified malts, special malts or rice. They are used only in small units, such as pub breweries. Gaps used are 0.6–1.0 mm (0.024–0.039 in.) and working capacities are 1.5–2.5 kg/h/mm roll length (a working rate of 1 kg/h/mm roll length is almost exactly 60 lb/h/in. roll length). It seems that three-roll mills (with or without screens) are no longer in use. The arrangement of the three rolls was like the grouping found in five-roll mills (see below; Sugden *et al.*, 1999).

Four-roll (two-high) mills are common in smaller, traditional ale breweries (Figs 5.3 and 5.4). They are robust, relatively inexpensive and well suited for milling well-modified malts with a small range of corn sizes. Working rates are 2–6 kg/h/mm, the gaps between the upper rolls are 1.3–1.9 mm (0.051–0.075 in.) and between the lower rolls 0.3–1.0 mm (0.012–0.039 in.). In the more simple types the cracked grist from the first rolls piles up on a ‘dam’, ‘shelf’ or ‘explosion preventer’, where it can smother any sparks and so prevent an explosion (Fig. 5.3). It then spills over and falls into a beater chamber, where the crushed malt is broken up and flour and grits are partly separated from the husk before passing through the second pair of rolls, over a second explosion preventer and out to the grist case. More sophisticated types of four-roll mills use screens to separate the grist into fractions of which only the coarse grits are crushed further by passage between the second pair of rolls

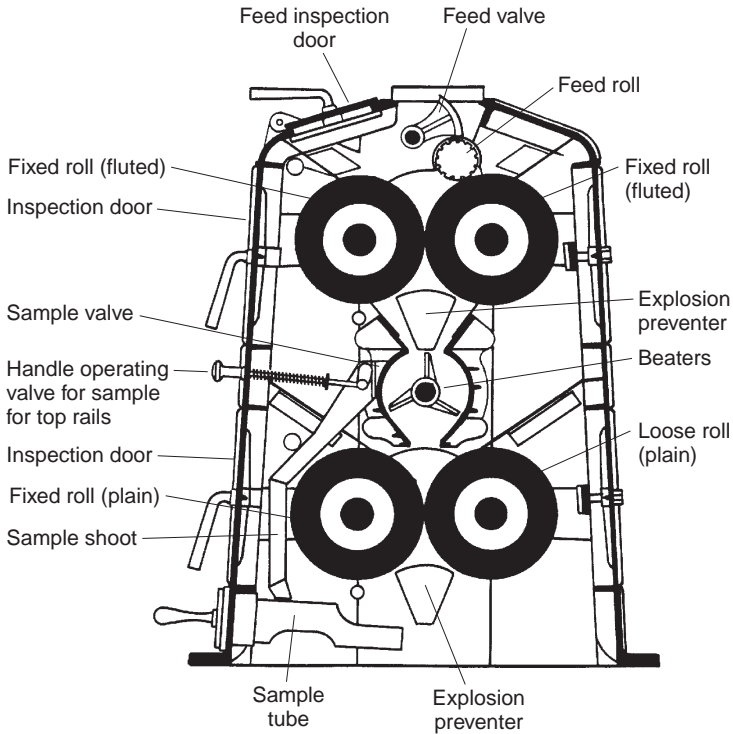

Fig. 5.3 A simple four-roll mill (after Hind, 1950). Note that in the second pair of rolls one is driven ('fixed') while the other is not powered ('loose').

(Fig. 5.4). This avoids more damage to the husk material and so favours a good wort run-off rate. The screens may be semi-cylindrical and equipped with revolving beaters, as in Fig. 5.4, or they may be oscillating, flat-bed screens. The larger the screen areas the better the separations achieved. The arrangements of the screens can be varied so that, for example, flour and grits are re-milled but husk is not or, alternatively, grits and husk are re-milled but flour and fine grits are not (Sugden *et al.*, 1999).

So-called eight-roll mills were really two four-roll mills working in parallel. The malt was pre-screened to divide it into bold (plump) and thin corns and these were milled separately, each stream passing through a four-roll mill adjusted to deal with the particular corn sizes. Five-roll mills are now uncommon (Fig. 5.5), but they are less expensive than the six-roll mills. The malt is crushed between the first pair of rolls (say 1 and 2) and the grist from this operation is screened. The husk fraction is crushed further, (between rolls 2 and 3) and the products are separated on a second set of screens which direct the flour and husks (with grits attached) to leave the mill, and the grits to pass through the third pair of rolls (say 4 and 5). At the same time the flour from the first pair of rolls is guided out of the mill and the grits join those from the second pair of rolls and are broken up further by the third pair.

Six-roll mills are widely used in larger breweries as they are flexible in their operation and are able to mill malts with differing degrees of modification and some adjuncts. Several arrangements of the rolls and screens are used (Sugden *et al.*, 1999; Wilkinson, 2001). In one type malt from the feed roll is crushed by the first pair of rolls and then by the second set of rolls (so at this stage the treatment resembles that given by simple four-roll mills). The grist from the second pair of rolls falls onto a set of screens, which divide

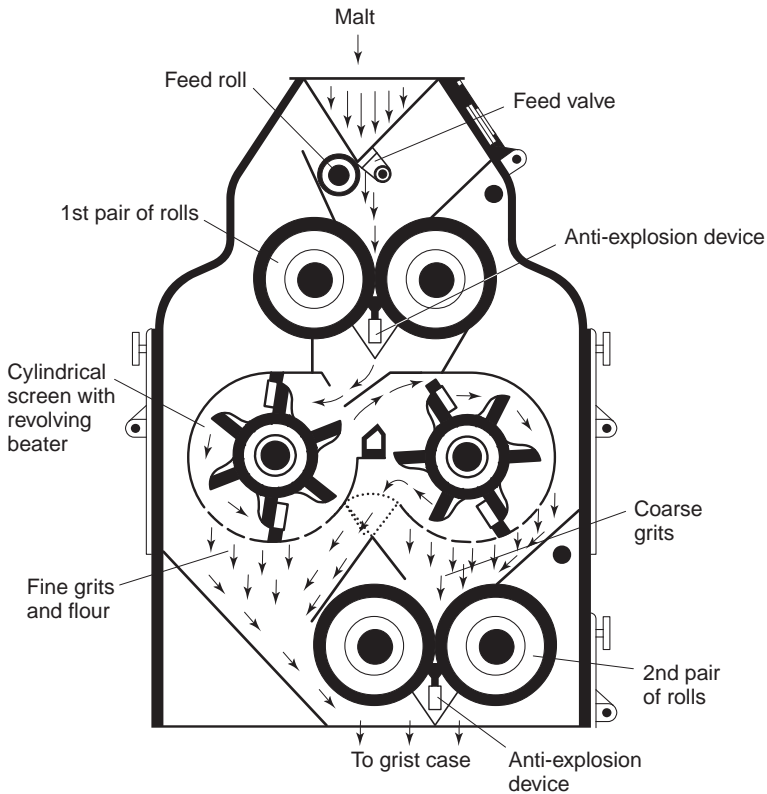

Fig. 5.4 A four-roll mill using cylindrical screens to fractionate the grist from the first pair of rolls and to direct the coarse grits to the second pair of rolls (after Hind, 1950). Similar results are obtained in mills with oscillating, flat-bed screens.

it into size fractions. Several different arrangements are then possible. For example, the husk and flour fractions leave the mill while the grits are broken more by passing between the third pair of rolls. In one particular system the grist from the first and second rolls is divided into two equal streams, which pass to two identical sets of tandem flat screens. This arrangement is compact and allows the use of large screen areas (and so more efficient fractionation of the grist) and, because the sets of screens are set to oscillate 'in opposition', the vibration of the mill is reduced.

The arrangement of a more common pattern of six-roll mill is shown in Fig. 5.6. Sets of screens operate between the first and second and second and third pairs of rolls. The coarse material from the first stage pass to the second set of rolls, the grits go to the third pair of rolls and the flour leaves the mill. The husk and flour from the second rolls leave the mill while the grits pass to the third pair. These mills, appropriately adjusted and with the correctly fluted rollers, can be used to prepare grists that are suitable for use in lauter tuns or the older types of mash filters. The malt delivered to these mills may be dry or 'conditioned' (see below). Suggested gaps (mm) for the first, second and third pairs of rolls are, (a) for dry malts and cereals using a lauter tun, 1.6–2.0, 0.7–1. and 0.2–0.4; (b) for conditioned malts using a lauter tun, 1.4–1.9, 0.5–1.0 and 0.2–0.4, while for dry malt and cereals using an older type of mash filter; (c) the values are 1.0–1.4, 0.4–0.6 and 0.1–0.3 (1 mm = 0.03937 in.). The working rates of six-roll mills are 2–10 kg/h/mm roll length for lauter tun grists and 1.5–8 kg/h/mm for mash filter grists.

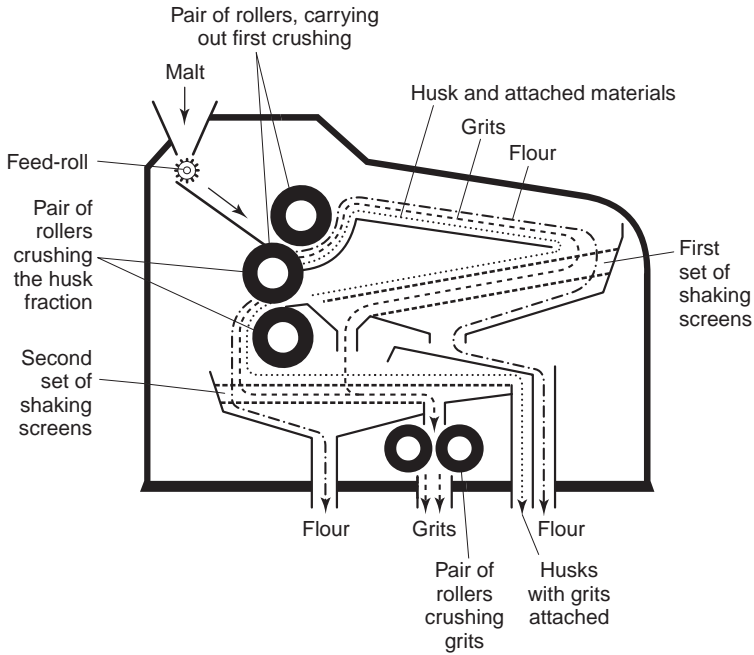

Fig. 5.5 The working principles of a five-roll mill (various sources).

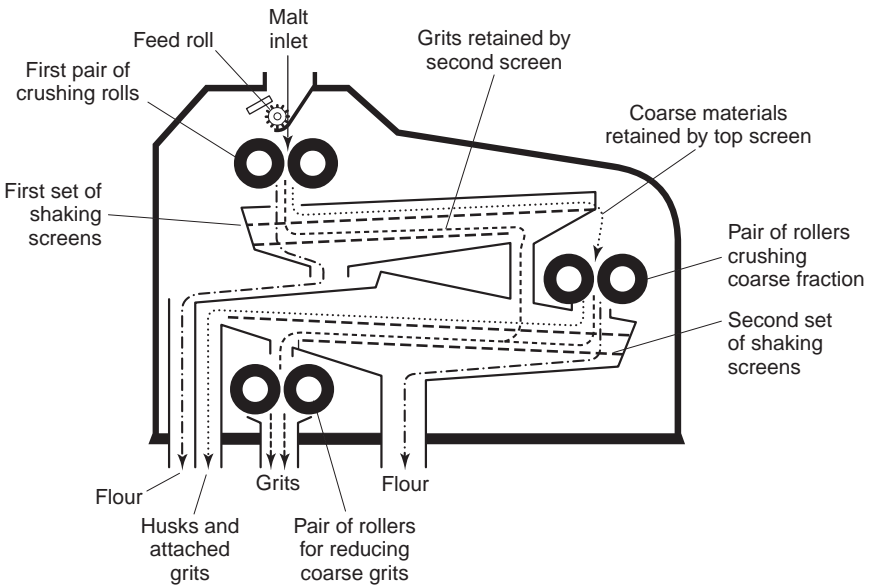

Fig. 5.6 A scheme of a six-roll mill (various sources).

5.5 Impact mills

Disc and pin ‘dry’ mills are often used on the experimental or pilot brewery scale and they are used in some small breweries (Biche *et al.*, 1999). In these mills the material to

be ground is delivered to the gap at the centre, between two discs the faces of which are roughened or covered with short projections. One disc may be static and the other rotate or both may spin, but in opposite directions. The gap between the discs may be adjusted. As the material moves from the centre to the periphery it is ground. Usually the grist is carried away in an airflow, but there has been interest in disc milling under water, when milling and mashing in occur together (see Section 5.9).

For years hammer milling has been used to prepare some raw grain adjuncts. It was also used experimentally and in a limited number of breweries for making finely ground grists from which, after mashing, worts were separated by centrifugation or with rotating vacuum filters (Briggs *et al.*, 1981; Rehberger and Luther, 1994). However, the introduction of high-pressure filters and the Meura 2001 filter has encouraged the use of hammer milling for grist preparation because in these devices the survival of large fragments of husk is irrelevant in collecting the wort. Hammer mills differ in detail, but the principles of operation are the same (Fig. 5.7). Malt, sometimes mixed with adjuncts, is fed at a pre-determined rate through a rotary valve or a feed roll, into the milling chamber, which is strongly ventilated. The chamber may be mounted vertically or horizontally. The malt must be scrupulously cleaned to remove stones, pieces of metal and 'heavy objects'. The milling chamber contains a spinning rotor (e.g. turning at 1500 rpm) on which are mounted freely swinging pieces of metal, the beaters or 'hammers', which travel at about 100 m/s. The inertia of the rotors is such that they may take 20–30 min. to stop.

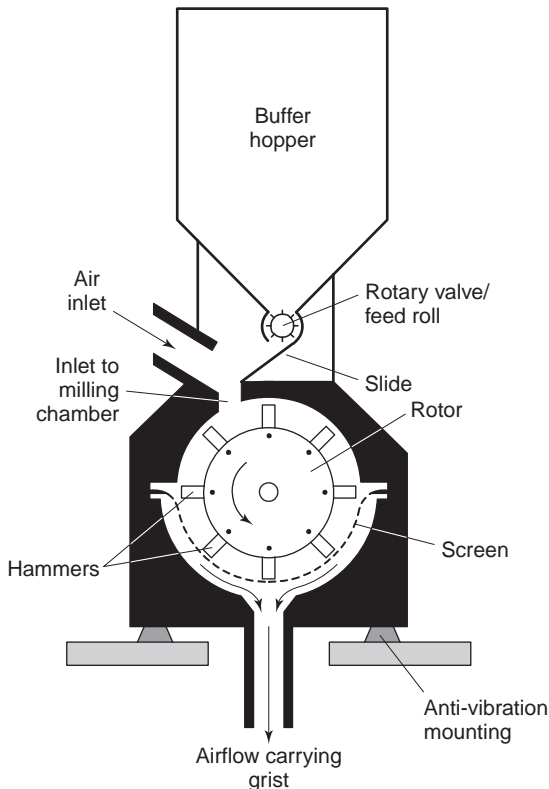

Fig. 5.7 The layout of a type of hammer mill (various sources).

The impacts of the hammers on the malt smash it up and this process continues until the fragments escape through the semicircular screen that makes up part of the wall of the chamber. Sometimes the inner wall of the chamber also carries short projections against which the moving malt can impact. The screens may have mesh widths of 0.5, 1.0 mm or even 2–4 mm. The powdered grist is carried out of the mill in the airflow, which transports it to the grist case, which is equipped with explosion vents. In some mills the rotors are reversible to obtain even wear on the hammers. These mills are comparatively inexpensive, but the wear is substantial and so maintenance must be regular and easy to carry out and screens and hammers need regular replacement. Such mills must be set up on anti-vibration mountings, and housed in acoustically insulated chambers, to muffle the noise.

5.6 Conditioned dry milling

In mashing and the subsequent separation of the wort from the spent grains, in mash tuns or lauter tuns, it is desirable that husk materials should be as nearly intact as possible, but with dry milling this is difficult to achieve while comminuting the endosperm tissue to an adequate extent. The problem is largely due to the extreme brittleness of the dry husk. The ideal arrangement for preparing most grists would be to be able to mill malt with damp, flexible husks but with dry, brittle interiors. To a degree this is achieved by ‘conditioning’ malt by briefly dampening it, wetting the husk with water or steam, before it reaches a conventional ‘dry’ mill (Fig. 5.1). The intention is to mill the treated malt while the husk is damp and flexible but before any moisture reaches the endosperm and reduces its brittleness. A conditioning screw consists of a screw or paddle conveyor working in a heated casing. The moving stream of warm malt may be exposed to low-pressure steam, at 0.5 bar, for 30–60 s. Then, after a 90–120 s equilibration time, the malt is delivered to a six-roll mill. To dry the equipment and minimize corrosion the steam is turned off 5 min. before the last of the malt passes through. Alternatively, and with a lower risk of enzyme inactivation, water at 30 °C (86 °F) or, at least, < 40 °C (104 °F), is sprayed onto the malt and then, after a one-minute equilibration period, the malt enters the mill. The moisture content of the husk is increased by 1.5–1.7%.

The dampened husk is more flexible and survives milling better and the volume of the husk sieve fraction is increased by 20–30%. Dry milled grist volumes are 500–700 ml/100 g while the volumes of conditioned milled grists are 700–1000 ml/100 g. The volumes of the spent grains are also increased. The mill gaps need to be set closer to obtain the best extract from conditioned malt. The run-off rate is increased by conditioning and lauter tuns may be loaded more deeply using a mash made with conditioned malt as the bed density is reduced and its porosity is increased (Narziss, 1992; Stoscheck, 1988; Sugden, *et al.*, 1999; Wilkinson, 2001). It is also said that conditioning gives a better yield of extract, better attenuation and faster saccharification. To prevent clogging dust must be completely removed from the malt before it reaches the conditioning screw and this and the adjacent pieces of equipment must be cleaned regularly.

5.7 Spray steep roller milling

Spray steeping malt before it is milled is a comparatively recent innovation. In spray steeping mills the malt is held dry in a hopper from which it is fed, at a controlled rate, into a spray chamber or conditioning shaft or chute, so designed that the malt moves through with a

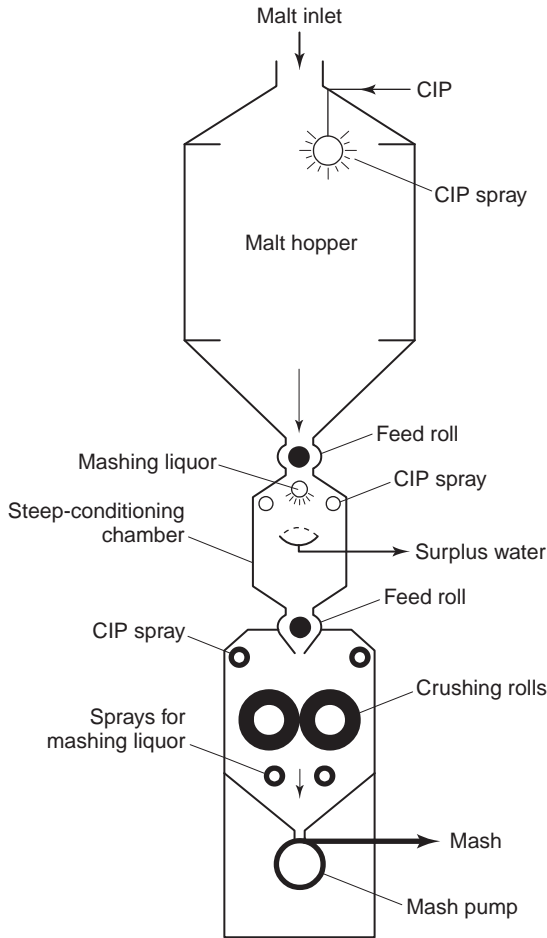

Fig. 5.8 A diagram of a mill using spray-steep conditioning (various sources). CIP, fittings of the ‘cleaning in place’ system.

‘plug flow’, that is ‘first in’ is ‘first out’ (Fig. 5.8). Here it is sprayed with warm/hot water for a short time, some quoted conditions being 60–80 °C (140–176 °F) for 45–60 s, or 50–70 °C (122–158 °F) for 60–120 s. (Herrmann, *et al.*, 1998; Kunze, 1996; Langenhan, 1992; Wilkinson, 2001). Surplus water is collected from the spray chamber and is re-circulated. Water usage is 30–80 litres/100 kg malt. Generally the mill has two large, stainless steel rolls of 290–420 mm (11.41–16.54 in.) diameter with a gap set at 0.2–0.5 mm (0.007–0.0197 in.), but four-roll versions are also used. If the malt is hard the mill ‘senses’ the increased workload, so the machine automatically runs more slowly, exposing the malt to a longer period of wetting. The moisture content of the husk is increased to 18–22%.

Immediately after milling the mashing water is added to the grist and the mixture is pumped to the mash vessel. Lactic acid can be added at this stage to adjust the pH of the mash. Because this method of milling and mashing allows air to be mixed into the mash there is a chance that unwanted oxidations may occur. This can be prevented by excluding air, by filling the mill chamber with carbon dioxide or nitrogen gas. Husk survives milling well, and endosperm tissue is adequately broken up. The entire milling/mashing process is complete in 20–30 minutes. In an alternative arrangement the malt is

metered into the mill by a rotating, segmented wheel (where it is wetted) which replaces the conditioning shaft (Kunze, 1996). This system has all the advantages of conditioned milling, that is, husk survival is enhanced, the grist and spent grains occupy a large volume so their porosity is increased giving shortened lauter times and good yields of extract. Between uses these mills must be thoroughly cleaned. They are equipped with CIP systems. The performance of these mills is relatively inflexible (Wilkinson, 2003).

5.8 Steep conditioning

In another, older type of wet mill the malt, with or without some raw cereal, is held in a hopper in which it is steeped (Fig. 5.9; Healy and Armitt, 1980; Kunze, 1996; Meisel, 1997; Narziss, 1992; Sugden *et al.*, 1999). The liquor used in the steep is usually at 30–50°C (86–122°F) and steeping lasts from 10 to 30 minutes. The steep liquor may be recirculated. After steeping the water is drained away, before the malt is milled. However, moisture takes time to penetrate the corns and so, inside the corns, the first malt to reach the mill is less moist than the last, so treatment is uneven. The malt has to be dust-free to prevent clogging. The steeped malt reaches a moisture content of about 30%, so the contents are partly softened. During milling they are gently squeezed flat by the large rolls (400 mm, 15.75 in. diameter; 440 rpm, gap 0.30–0.45 mm, approx. 0.012–0.018 in.) of the mill, squeezing out some of their contents.

A mill may have two or four rolls. As with spray steeping the husks remain intact but hard ends in the malt are probably not adequately disrupted. Wet milling gives rise to a large volume of spent grains, indicating that mashes are ‘open’ and that the beds have high porosity. The control of the moisture content of the malt is less exact than that

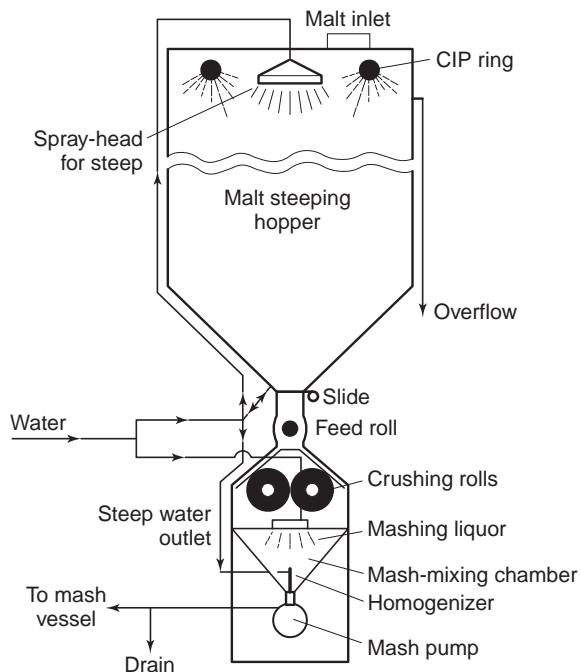

Fig. 5.9 A mill using steep conditioning (various sources).

achieved with spray steeping and the mill must be cleaned very well, initially with hot mashing liquor, to prevent microbes multiplying. The steep water may be discarded, in which case some extract is lost and effluent is produced or it may be added to the mashing liquor. This may carry a flavour penalty. Mashing liquor is added to the mixture immediately after milling and after mixing the mash is transferred to the mash vessel using a mash pump. Advantages claimed for this system include increased brewhouse yield, faster wort separation in the lauter tun and smoother tasting beers as well as dust suppression (Stauffer, 1974). On the other hand the system is inflexible and has other inherent disadvantages (Wilkinson, 2001). Spray steeping, with its ability to break up dry and brittle endosperm while keeping husk tissue intact, is now preferred.

5.9 Milling under water

Experimentally, other types of wet milling are being investigated. It has been found that by steeping malt and by grinding it under water in a disc mill, a fine grist suitable for use in a Meura 2001 mash filter can be rapidly produced (Biche *et al.*, 1999; De Brackeleire *et al.*, 2000; Wilkinson, 2003). Milling and mashing in occur together. The milling discs (often 600 mm, 23.6 in. diameter) rotate at 1275 rpm. The gap between the discs is variable, 0.35–0.55 mm (0.0138–0.0217 in.) often being used. The smaller the gap between the plates the finer the grind achieved, but with a greater power consumption. To prevent oxidation it is desirable to de-gas the liquor and displace the air from the malt using an inert gas. The system is said to be slightly superior to hammer milling and to give a grist with very good filterability and a high yield of extract.

Another proposal is to obtain an exceptionally fine grind by breaking up malt and adjuncts in a ‘dispersion chamber’ (Menger *et al.*, 2000a, b). In this device the mixture of malt and water passes through a series of spinning, short, slotted rotors and stators which disrupt it by shear and probably impacts. Thus milling and mashing in are carried out together. Again, it is desirable to de-aerate the liquor to minimize oxidative changes. Within limits it is possible to increase the fineness of the grist by using more disrupting units in the series, set to achieve increasing degrees of disaggregation.

5.10 Grist cases

With wet mills, milling is coincident with mashing in and so the entire operation must be completed in a comparatively short time, say 20–30 minutes. However, this is not the case with dry milling as the grist can be accumulated and stored, at least for a short period, ready for mashing in, in a separate operation. Dry grists can be evaluated using standard sieves (Tables 5.1, 5.4). Grist cases can have low bulk densities; for example, 100 kg can occupy 3 hl (approx 20.8 lb./ft.³). Thus a dry milled grist may occupy 2.6 hl/kg, while a conditioned malt grist might occupy 3.2 hl/kg (Narziss, 1992). Thus grist cases, the containers in which grists are stored, have large volumes and must contain enough grist for a mash. Usually they are made of mild steel, and are designed to contain dust and exclude steam and damp air, while being able to release their load under gravity, at the required rate. Sometimes the cases are fed from a mill and, by a proportional feeder, from a store of an adjunct such as wheat flour, that needs to be mixed uniformly into the grist. The grist may be directed to the mashing in system through a chute or by way of a gentle belt conveyor. Unless the grist is intended for a new type of mash filter abrasion caused

by rough conveying or handling should be avoided so that the grist is not broken down further. All the components of a grist should be well mixed, and so any vibrations or conveying that favour the segregation of the components of the grist, for example, into layers of husk and fines, must be avoided. Commonly a grist case is above one mashing vessel, which it serves. However, sometimes a grist case can be equipped with chutes or conveyors that allow it to serve more than one mashing vessel, while other grist cases can be moved so that they can serve more than one vessel and several containers, each containing enough grist for one mash, may be grouped together in one structure.

In two old processes, that have fallen out of use, the grist in the case could be heated by steam-heated pipes placed in the grist case. In 'retorrification' the grist was warmed to the mashing-in temperature. Thus the temperature of the mashing liquor did not need to be greatly above that of the grist to achieve the correct initial heat, and so thermal inactivation of enzymes, caused by local overheating, was minimized on mashing in and more uniform mashing temperatures were achieved when the ambient temperature fluctuated.

When grists were subjected to 'aromatization' they were heated to about 130°C (266°F) for 15 minutes to increase the colour and aroma. Inevitably this must have caused some enzyme inactivation.

5.11 References

- BHADURI, R. (1996) *Brew. Distill. Internat.*, Mar., 18.
- BICHE, J., HARMEGNIES, F. and TIGEL, R. (1999) *Proc. 27th Congr. Eur. Brew. Conv., Cannes*, p. 593.
- BRIGGS, D. E. (1998) *Malts and Malting*. London. Blackie Academic and Professional, 796 pp.
- BRIGGS, D. E., HOUGH, J. S., STEVENS, R. and YOUNG, T. W. (1981) *Malting and Brewing Science (2nd edn)*. Vol. 1. *Malt and Sweet Wort*. London. Chapman and Hall, 387 pp.
- CRESCENZI, A. M. (1987) *J. Inst. Brewing*, **93**, 193.
- DE BRACKELEIRE, C., HARMEGNIES, F., TIGEL, R. and MENDES, J. P. (2000) *Brauwelt Internat.*, **18**(5), 372.
- FARNISH, R. (2002) *Brewers' Guard.*, Feb., p. 26.
- HEALY, P. and ARMITT, J. D. G. (1980) *Proc. 16th Conv. Inst Brewing (Australia and New Zealand Section)*, Sydney, p. 91.
- HERRMANN, H., KANTELBERG, B. and WIESNER, R. (1998) *Brauwelt Internat.*, **16**(1), 44.
- HIND, H. L. (1950) *Brewing Science and Practice, Vol. II. Brewing Processes*. London, Chapman and Hall, pp. 507–1020.
- ISOE, A., KANAGAWA, K., ONO, M., NAKATANI, K. and NISHIGAKI, M. (1991) *Proc. 23rd Congr. Eur. Brew. Conv., Lisbon*, p. 697.
- KROTTENTHALER, M., ZÜRCHER, J., SCHNEIDER, J., BACK, W. and WEISSER, H. (1999) *Proc. 27th Congr. Eur. Brew. Conv., Cannes*, p. 603.
- KUNZE, W. (1996) *Technology Brewing and Malting*. (Wainwright, T. Transl.) Berlin, VLB, 726 pp.
- LANGENHAN, R. (1992) *Brew. Distill. Internat.*, **23**(5), 16.
- MEISEL, D. (1997) *A Practical Guide to Good Lager Brewing Practice*. Inst. Brewing, (Central and Southern African Sect.).
- MENGER, H.-J., SALZGEBER, G. and PIEPER, H. J. (2000a) *Brauwelt Internat.*, **18**(1), 54.
- MENGER, H.-J., MIROLL, F., FORCH, M., BIURRIN, R., SCHWILL-MIEDANER, A., HERRMAN, J. and RAPP, T. (2000b) *Brauwelt Internat.*, **18**(2), 120.
- NARZISS, L. (1992) *Die Bierbrauerei. (7nt Auflage) Bd. II. Die Technologie der Würzebereitung*. Stuttgart. Ferdinand Enke Verlag, 402 pp.
- NICOL, S. O. and ANDREWS, J. M. H. (1996) *Ferment.*, **9**(3), 145.
- REHBERGER, A. J. and LUTHER, G. E. (1994) in *Handbook of Brewing* (Hardwick, W. A. ed.). New York, Marcel Dekker Inc., p. 247.
- STAUFFER, J. (1974) *MBAA Tech. Quart.*, **11**, (4), 240.
- STOSCHECK, W. (1988) *MBAA Tech. Quart.*, **25**(2), 108.
- STUBITS, M., TENG, J. and PEREIRA, J. (1986) *J. Amer. Soc. Brew. Chem.*, **44**(1), 12.
- SUGDEN, T. D., WEBB, C., BYRNE, H., VAN WAESBERGHE, J. and WULFF, T. (1999) *Milling. E. B. C. Handbook of Good Practice*. Nürnberg. Hans Carl, 102 pp.
- WILKINSON, R. (2001) *Brewers' Guard.*, **130**, (4), 29.
- WILKINSON, R. (2003) *Brewers' Guard.*, **132**, (1), 26.

6

Mashing technology

6.1 Introduction

Mashing is the process by which sweet wort is prepared. It involves ‘mashing in’, the mixing of the milled grist and the brewing liquor at the correct temperature and in the correct proportions to obtain the mash. After a period, with or without temperature changes, during which the necessary biochemical changes occur, the liquid ‘sweet wort’, which contains the extract, is separated from the residual solids, the ‘spent grains’ or ‘draff’. Some extract remains in the draff, and as much of this as possible is recovered by ‘sparging’, washing the grains with hot brewing liquor.

In traditional brewing, as practised in homes or small inns, hot water was placed in a wooden tub or tun, and the grist (malt that had been ground between millstones) was mixed and mashed in by stirring or rowing with a rake, paddle or ‘oar’ (Fig. 6.1). No reliable means of measuring temperatures was available. In one method, which gave rise to the ‘classical’ British infusion system, the water temperature was guessed to be suitable by feel or by how clearly the brewer’s face was reflected in the water. After a period a basket was pushed into the mash and wort that seeped into it was ladled into a receiver, in readiness for boiling with hops or other flavouring herbs. When wort recovery became difficult more hot water was mixed into the mash (re-mashing) and another, weaker wort was recovered. This was repeated until the worts were too weak to be worth collecting. In later times wort was collected from mashes using primitive mash tuns, in which the wort drained from the mash through a perforated ‘strainer’ in the base of the tun. The structures of old (approx. 200 years), relatively small British country house breweries are documented (Sambrook, 1996).

In an alternative method, which gave rise to the classical mainland European decoction mashing system, traditionally used for brewing lager beers, the mash was made with slightly warm water. At intervals a ‘decoction’ was carried out, that is, a proportion of the mash, perhaps one-third, was withdrawn and slowly raised to boiling in the copper that would later be used for boiling the wort. The hot mash was then transferred back to the ‘main mash’, and was mixed in. In this way the temperature of the whole mash was increased. Repeated decoctions increased the mash temperature in steps, an approach that

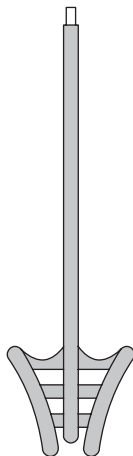

Fig. 6.1 A wooden mashing rake or oar.

minimized the risk of overheating and premature total enzyme destruction. In more modern variations of this system the temperatures achieved (now exactly controlled) are optimal for various enzyme-catalysed processes in the mash and allow comparatively under-modified malts to be mashed successfully (Chapter 4). Raw cereal adjuncts may conveniently be cooked in decoction vessels. In contrast, the traditional infusion system of mashing requires well-modified malts and not more than about 20% of unmalted adjuncts (Chapter 4).

The equipment used in breweries has been progressively refined and there has been a convergence in the practices of ale and lager brewers. The motives for these alterations are chiefly economic. It is often desirable to maximize productivity ('throughput', the number of brews completed every 24 h) and to recover as much extract as is economically worthwhile from a given grist (Chapter 18). It is also necessary to reproducibly recover a certain volume of wort having exactly the characteristics needed to make a particular beer. At the same time energy and water usage must be minimized and so must the production of effluents. At the present time there are breweries operating with many different kinds of 'traditional' and 'modern' equipment. The more common types will be described. Sometimes old types of plant have been retained, despite some inconvenience or poorer efficiency, because a newer system has not been able to produce a beer matching that produced by the old system. In the case of smaller breweries older kinds of equipment may be retained because of its simplicity, or because replacement is not economic. While older equipment is often made of attractive polished wood and copper, in newer equipment these materials have been largely replaced by the cheaper, more deterioration-resistant stainless steels (Chapter 10).

6.2 Mashing in

Mashing in, the process of mixing the mashing liquor and the grist, is critical. The proportions of liquor to grist and the temperature of the mixture must both be correct and the grist must be evenly mixed in the mash, with no clumping or 'balling', which reduces extract recovery, and no segregation of the grist components. In traditional infusion mashing, where it is not easy to adjust the mash temperature, the value initially attained is

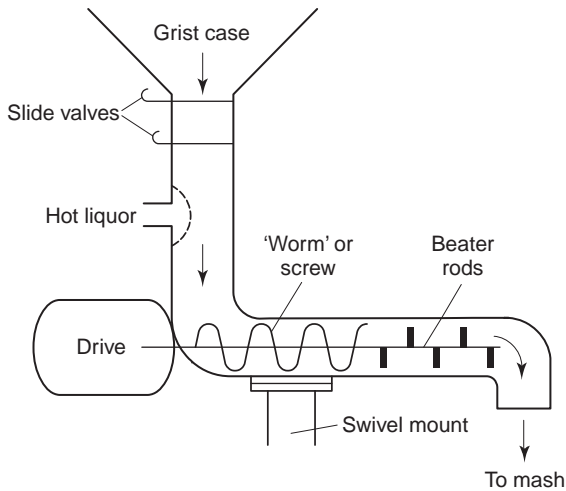

Fig. 6.2 Steel's mashing machine, used in traditional British infusion mashing. In more modern versions the rate of grist flow is regulated mechanically and the slide valves prevent steam from the mash travelling into the grist case.

critical. Historically, grist was poured into attemperated water in the mash tun or 'tub' and was mixed in by 'rowing', a laborious process that often resulted in inadequate mixing and balls of unmixed grist. Mechanical means of mixing mashes were necessary. Mash tun rakes were invented by Matterface in 1807 (see below; Sykes and Ling, 1907). This kind of equipment remained widely in use in the UK until the 1960s. It is now rare. Several 'external' mashing machines were invented and, in various forms, some of these are still in use.

The Steel's masher, introduced in 1853, consists of a horizontal tube about 46 cm (18 in.) in diameter and was once typical of ale breweries (Fig. 6.2). Grist from the grist-case is delivered to one end via a vertical tube at a controlled rate. Slide valves are used to prevent vapour from the mash rising into the grist case. The grist is sprayed with mashing liquor and the wetted material is driven along the tube by a screw conveyor and is then mixed by a series of short beater-rods mounted on the same shaft as the conveyor screw. The mashed material is then dropped from a spout into the vessel below. This device is capable of mixing the thick mashes typical of traditional infusion mashing (e.g. 1.6–3.2 hl liquor/100 kg grist; 9.9–19.9 imp. brl/ton). With this system it is impossible to prevent oxygen uptake. Sometimes the masher is mounted so that it can be swivelled sideways and so can deliver into either of two vessels.

Mash hydrators, or 'pre-mashers', are designed for making the thinner mashes used in decoction mashing or temperature-programmed infusion mashing (3.3–5 hl liquor/100 kg grist; 20.5–31.0 imp. brl/ton), which must be stirred and pumped between vessels. In general, light beers are made with more dilute mashes than those used for dark beers. In mash hydrators grist, falling down a tube at a controlled rate, meets a spray of attemperated water flowing at a controlled rate from a perforated central tube or from a surrounding casing (Figs 6.3, 6.4). In other increasingly common devices the water is injected tangentially creating a vortex, which rapidly mixes with the grist (Fig. 6.5). This device contains dust and minimizes oxygen pick up. It is desirable that the mash from the hydrator does not fall into the mash, but is directed onto the side of the mashing vessel, or is pumped into the base, so that it slides down to the mash with the minimum uptake of

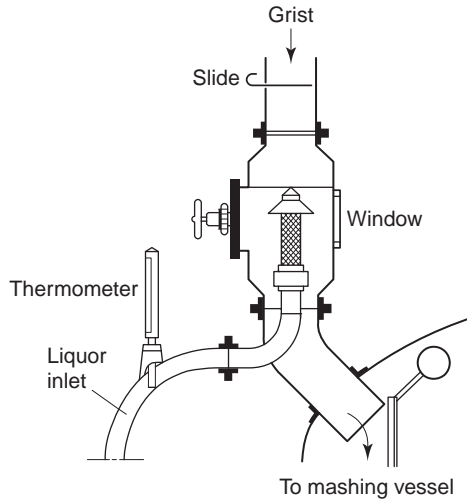

Fig. 6.3 Premasher or Maitland grist hydrator, of a traditional mainland European type, used in conjunction with decoction mashing (after Narziss, 1992). Note that the grist falls past a perforated tube, which delivers the mashing liquor. The mixture pushes open a counter-balanced door and falls into the vessel.

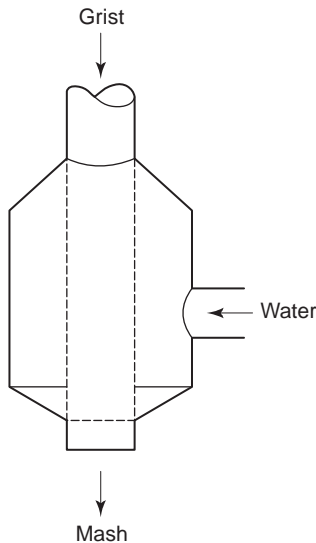

Fig. 6.4 An alternative type of mash hydrator (after Rehberger and Luther, 1994).

oxygen (Wilkinson, 2003). None of these devices has moving parts to wear out. A spray-ball should always be mounted above the liquor inlet to facilitate ‘cleaning in-place’, CIP. The grist from the hydrator is not uniformly hydrated. Hydration is completed during stirring in the mashing vessel.

In addition to the methods mentioned, wet milling coincides with mashing in and so with this approach no grist case is involved (Chapter 5). In some plants the material from the pre-masher enters an inclined disc mixing vessel. This consists of a cylinder with rounded ends mounted on its side and having a longitudinal shaft mounted about a third

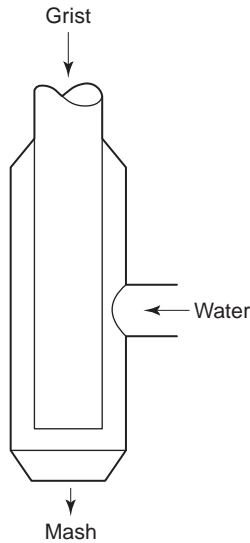

Fig. 6.5 A vortex mash mixer (after Rehberger and Luther, 1994). The grist falls into a swirling tube of liquor from that tangentially injected into the outer chamber. With these, and other pre-hydrators, it is desirable to have a mixing chamber through which the grist must pass before it leaves the unit.

of the way up from the bottom. The shaft carries a series of discs inclined at angles to the shaft which rotates. The discs mix the mash very gently and thoroughly (Kunze, 1996).

In most plants it is usual for the pre-hydrated grist to be transferred into a mashing vessel, where mixing occurs. To minimize oxidative changes in the mash or wort, the mash may be gently pumped into the vessel at the side or up through the base, so minimizing turbulence and the uptake of oxygen. Degassing the mashing liquor, flushing the grist with an inert gas such as nitrogen or carbon dioxide and filling the base of the vessel with an inert gas to displace air and so limit oxygen pick-up may also be used (Yamaguchi *et al.*, 1997).

In many breweries the older names for critical temperatures are retained (Hind, 1940). Thus liquor heat and striking heat are terms for the temperature of the mashing liquor in the hot water tank and at the mashing machine respectively. The initial heat is the temperature of the freshly mixed mash, sparge heat is the temperature of the sparging liquor and the tap heat is the temperature of the wort as it is drawn off. In infusion mashing in modern mash tuns the opportunities for adjusting the mash temperature are limited and it is essential to achieve the correct initial heat (temperature) when mashing in. In modern plant this may be achieved automatically by varying the temperature of the mashing liquor so that the correct initial heat is attained. In older plant this is achieved by a skilled operator's judgement, guided initially by calculation and later by experience.

When malt is mixed with water heat is generated and this slaking heat or heat of hydration is less for malts with higher moisture contents (Table 6.1). So, for example, a malt with a moisture content of 2%, mashed in a particular way, may give a temperature rise of about 4.8°C (8.6°F), while a malt with a moisture content of 6% would give a temperature rise of 2.6°C (4.6°F) when mashed in the same way. The initial heat of the mash can be calculated from the formula

$$I = [St + RT/S+R] + [0.5H/S+R]$$

Table 6.1 The specific heats and slaking heats of malt at different moisture contents. Other malts may have slightly different values. Data recalculated, by interpolation, from the data of (a) Brown (1910) and (b) Hopkins and Carter (1933)

Moisture (%)	Specific heat (a)	Slaking heat at 65 °C (150 °F)			
		g.cal/°F		g.cal/°C	
		(a)	(b)	(a)	(b)
0	0.38	28.0	33.4	15.6	18.6
1	0.38	24.7	28.7	13.7	15.9
2	0.39	21.5	24.9	11.9	13.8
4	0.40	15.8	18.8	8.8	10.4
6	0.41	11.5	14.2	6.4	7.9
8	0.42	8.5	11.7	4.7	6.5

where S = specific heat of the malt, t = the temperature of the malt, R = the weight of water, relative to the unit weight of the malt, T is the temperature of the water, H is the slaking heat of the malt expressed in the correct units and I is the initial temperature of the mash. Others prefer to use H (rather than 0.5H) and make allowances for heat losses, determined by trial and error. The final temperature of a mash warmed by ‘underletting’, that is the addition of hot liquor to the mash, can be calculated from the formula

$$\text{Final temperature} = [M(S+R) + QT] / (S+R+Q)$$

where M = temperature of the mash at the time of underletting, Q is the quantity of water used in the underlet, T = temperature of the underlet liquor. The other symbols are as used before. These calculations can be used only for guidance. They cannot give exact results because no allowance is made for heat losses from the system, and these will vary with the temperature of the brewhouse.

6.3 The mash tun

The mash tun (‘kieve’ in Ireland) is the simplest device for mashing and preparing sweet wort. Mash conversion and wort separation from the spent grains take place in one vessel, and so mash tuns should be distinguished from the mash mixing and incubation vessels which are used to carry out the mash conversion step only, wort collection being carried out in a separate device, usually a lauter tun or a mash filter.

6.3.1 Construction

Mash tuns are circular in cross-section and vary greatly in size, but they are usually 2.0–2.5 m (approx. 6–8 ft.) in depth. Originally the tuns were of wood and, for many years most were equipped with raking machinery (Fig. 6.6). Wood is hard to clean and has only a limited life. Increasingly, mash tuns were made of iron or copper or, more recently, stainless steel. The properties of some materials used in the construction of brewing vessels are outlined in Chapter 10. They are insulated at the base and around the sides and are often clad with wood. Originally the tuns were open, but now they are usually covered with metal domes, equipped with inspection ports and lights.

Covering a tun slows heat loss and prevents the water vapour from the mash spreading through the brewing room (Fig. 6.7). Sometimes the vapours are carried away in a pipe

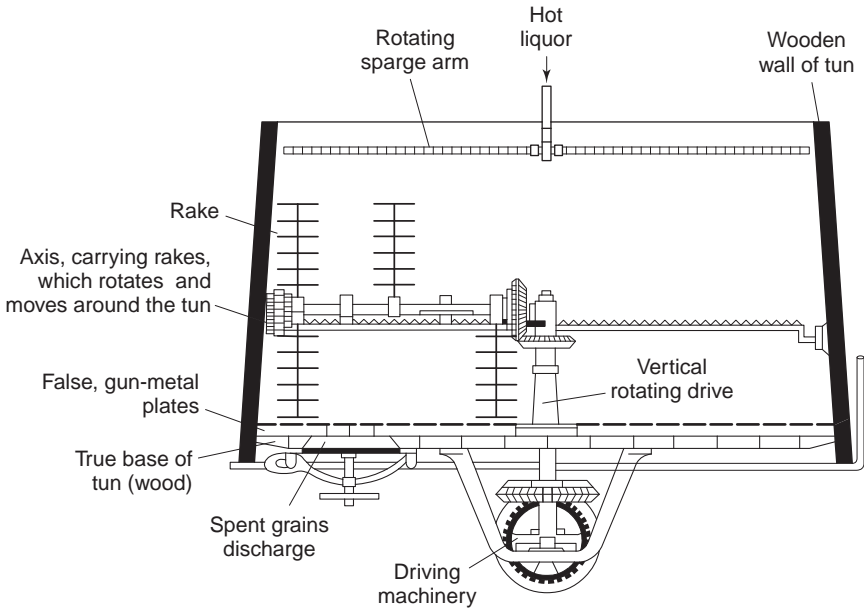

Fig. 6.6 An old pattern of mash tun as used in about 1880 (various sources). Some few of this general type are still in use.

fitted to the dome. The true base of the tun is covered by a 'false bottom' or deck. This consists of interlocking slotted (or drilled in some small tuns) metal plates of gun-metal or stainless steel or of stainless steel wedge wire (Figs 6.8, 6.9) mounted on short legs about 5–7.6 cm (2–3 in.) above the true base. The plates interlock in a unique pattern and can be lifted for cleaning or repairs. The slots give a free area of about 10–12% of the false bottom, while wedge wire gives the same or a higher value (up to 22%). The slots are typically 0.7–1.0 mm (0.028–0.039 in.) wide at the top and widen out below to facilitate cleaning and reduce the chances of fragments of grist wedging in the spaces. In the past all cleaning was by hand, involving the regular lifting of the plates of the false bottom and later re-assembling them, but now sprays may be fitted to allow CIP both above and below the deck. One, or more, large holes, fitted with valves, are in the false bottom. These are opened at the end of mashing to allow the removal of the spent grains and some rinse water.

In the past, grain removal was by hand but now, except in small breweries where manual removal is still used, grains are swept out of the discharge ports by horizontally rotating arms. The grains are collected and transferred by screw conveyor or compressed air to the collection silo for removal to farms or animal compounders. An alternative procedure of slurring the grains with water and pumping the mixture to a collection tank has been discontinued because wetting the spent grains reduces their value and the use of more water and the production of effluent with a high BOD increases costs. Few English breweries have retained rotating rakes. The machinery is clumsy and it is suspected of allowing channelling during sparging, with a consequent reduction in extract recovery. On the other hand rakes facilitate mixing the mash with underlet water, allowing controlled increases in temperature.

Some few mash tuns have been equipped with knives for 'cutting' the mash and for discharging the grains, as is done in many lauter tuns (Section 6.5). Originally drained

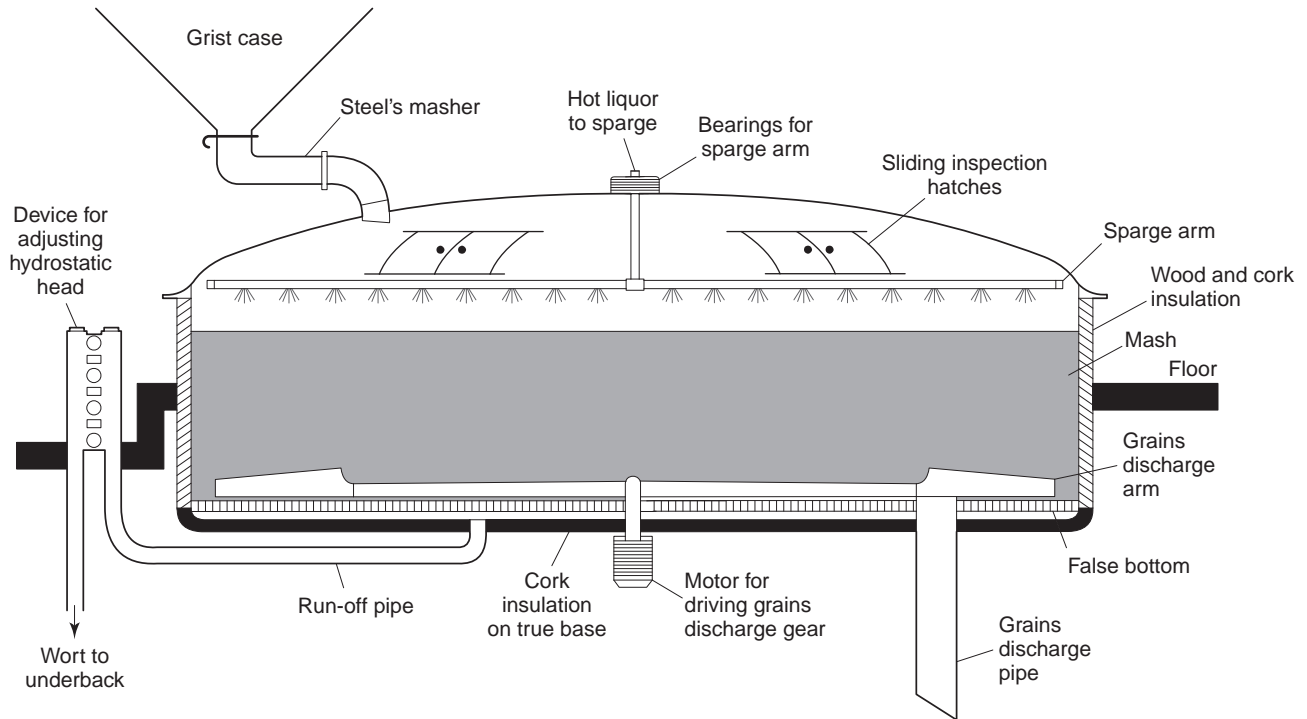

Fig. 6.7 A current pattern of mash tun (after Briggs *et al.*, 1981).

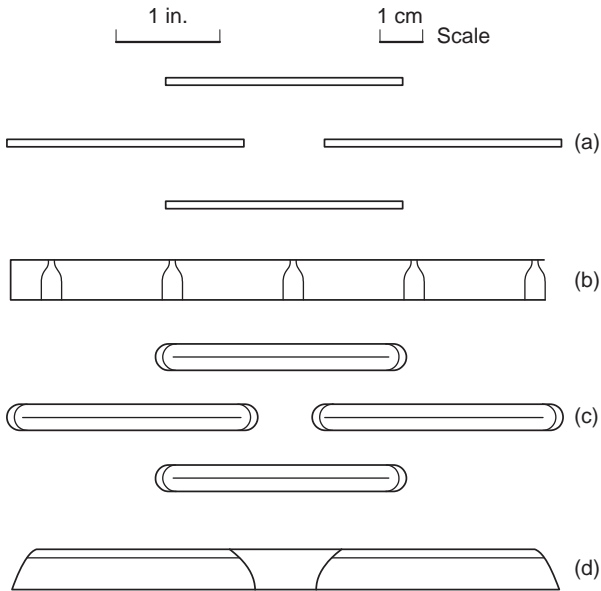

Fig. 6.8 Slots in plates that form the false bottoms of mash tuns (after Briggs *et al.*, 1981). (a) Plan view of the upper surface. (b) Vertical section across the slots. (c) Plan view of the lower surface. (d) A vertical section, at right-angles to (b), along two slots.

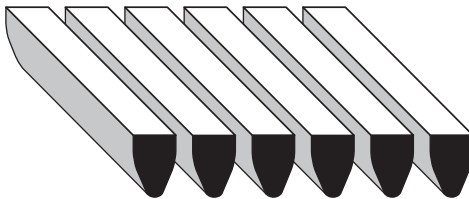

Fig. 6.9 A piece of wedge wire (after various sources).

grains were remashed with fresh hot water to recover entrained extract. Now ‘sparging’ is employed. Hot water is sprinkled onto the surface of the mash from centrally mounted, rotating perforated tubes, the sparge arms. These may be mechanically driven, but more usually they are driven by their reaction to the streams of water coming from the perforations, which are at an angle to the vertical (Fig. 6.7). Because it is desirable to apply the sparge liquor equally to all areas of the mash the perforations are more widely spaced towards the centre of the tun and more closely spaced towards the periphery. During wort collection the liquid is driven down through the bed of grain by the pressure difference between the liquid at the top of the mash and the pressure below the false bottom. This pressure difference is measured. To control this pressure difference, and hence the ‘suction’ on the grain bed and its compression, various devices, which act as weirs, may be used including a swinging, inverted U-tube (a Valentine tube), or a device equivalent to it (Fig. 6.7). Alternatively the rate of collection can be regulated with a pump, and the rate of sparging can be set to equal the rate of run-off using two matched pumps. Excessive pressure can force the goods down onto the plates and cause blockages or so compress the bed that the resistance to the flow of the liquid through the bed is high and run-off is slowed. The result is a set mash.

To obtain an even run-off and sparge it is desirable to have multiple wort collection pipes, connected to the true bottom of the tun, distributed in an even pattern. The object is to have each pipe draining the same area beneath the deck, say $1.9\text{--}2.3\text{ m}^2$ ($20\text{--}25\text{ ft.}^2$). In the traditional arrangement these discharge the wort via taps and swan-necked tubes into an open collecting trough. This allows the clarity, the gravity and the rate of flow of the wort from each tap to be checked. By manipulating the taps the rate of flow can be regulated and balanced. Differences in the quality of the wort from different taps indicates problems with the quality of the grain bed or the sparge.

6.3.2 Mash tun operations

Before use the clean mash tun is preheated to the mashing temperature with steam or hot water. All taps are closed, the temperature of the mashing liquor is checked and so are the contents of the grist case. Some liquor is admitted into the base of the tun to drive air out from beneath the false bottom and to cover the plates with a layer of water 2–5 cm (roughly 1–2 in.) deep. This cushions the mash as it is dropped in from the Steel's or other premasher, helps the mash to spread across the false base and reduces the chance of the slots being blocked. Mashing in may take 20–30 min. In modern mash tuns the mash entrains air and most of the goods float (Harris, 1968, 1971). In older tuns the mash was raked for a few minutes to mix the contents. The depth of the mash is typically 0.91–1.5 m (approx. 3–5 ft.), but depths of up to 2.74 m (9 ft.) have been used. One advantage of mash tuns is that they can be used with mashes of widely varying volumes.

The mash then begins its stand, normally a period of 1.25–2.5 h, to allow all necessary biochemical processes to take place. The temperature of the mash during the stand is not normally altered, but this is a comparatively recent development. Formerly moderate upward temperature adjustments were usual (Chapter 4; Hind, 1940; Sykes and Ling, 1907). The application of heat to a thick mash through a heater in the walls and base of an unstirred mash tun is not efficient. At various times heat increases were brought about with steam-heated coils beneath the false bottom or by direct steam injection, by cycling wort from the base of the tun to the top of the mash via an external heater, by a 'steam plough' (a device heated by steam or water which rotated with the machinery near to the base of the tun) or by underletting (sometimes with simultaneous sparging). With underletting, the most usual method, the calculated volume of hot liquor, at an appropriate temperature, was slowly let into the base of the tun, beneath the plates and raising the mash bed without disrupting it, then the mash was mixed, so its temperature was increased and it was diluted.

Sometimes wort run off becomes slow or even ceases. This is liable to occur if poor quality malt has been used, if the grist has been milled too finely, if the grist contains a high proportion of adjuncts, or if the operator has tried to draw off wort too quickly and has pulled the mash down onto the plates and caused the bed to become compressed. Such a 'set mash' may be cleared by using an underlet to lift the goods off the plates. Set mashes caused by poor quality grist components are made less likely by adding an enzyme preparation containing β -glucanase, cellulase and pentosanase activities. Drainage from the mash is dependent on it having an open structure and this, in turn, requires that the malt husk fraction be damaged as little as possible during milling (Chapter 5). In the past some brewers used a proportion of 'husky' malt or even added chopped straw or oat husks to 'open-out' the mash and aid drainage. The addition of such materials is undesirable as unwanted flavours can be conferred to the beer.

When the stand, with or without an underlet, is completed the first wort is run off. The first runnings may be a little turbid, and these are usually pumped back to the top of the

mash and recirculated. When the wort is perfectly clear (i.e. is 'running bright') the flow is diverted and the liquid is either collected in a holding vessel, an underback, where it is maintained at 71–82 °C (160–180 °F) to prevent the multiplication of contaminating microbes, or it is transferred directly to the copper. When the 'first worts' have been collected and the mash has settled, but before the surface of the grains has become dry, sparging begins, the hot water (usually at about 78 °C, 172.4 °F) being sprinkled on from the rotating sparge arms. The sparging rate matches the rate of wort run off, and the liquor displaces the wort downward and through the plates and leaches extract from the grist particles. The high temperature facilitates extract recovery because it reduces the viscosity of the wort and so facilitates run off and it accelerates the leaching of extract from the grist.

After the first worts have been collected the specific gravity of the collected wort begins to fall. The decline continues until a chosen gravity (often SG 1003–1005, 0.78–1.3 °P) is reached, when collection ceases. The goods are then allowed to drain. The drainings may be sent to waste, with a consequent loss of extract and at the cost of an effluent charge, or they may be stored hot for a short period and then be mixed into a subsequent mash, when the extract is recovered. However, the quality of the extract in the drainings is inferior to that in the main wort. Sparging often lasts 4–5 h. The sparge liquor should not contain 'temporary hardness' and should contain an adequate level of calcium ions (Chapter 4). At higher pH values more tannins and undesirable materials are extracted, leading to reductions in beer quality. About 5.35 hl of sparge liquor may be used for 100 kg malt (33 imp. brl/ton) so in all a total of about 8.1 hl of liquor are used for each 100 kg malt (50.3 imp. brl/ton). Some of this liquor, perhaps 2%, remains in the spent grains. The spent grains have a moisture content of about 80%. These are discharged and the tun is cleaned before the next mash. The entire cycle time with a mash tun is often 5–9 h, but in one famous brewery the time was 18 h and mashing in began at midnight. So mash tuns generate clear, high-quality ale worts which, because the meshes are thick, can produce high-gravity worts but by modern standards their turn-round times are slow. Oxygen exclusion is not feasible but for traditional ales it is not necessary. The thick bed of grains allows the production of very bright worts but also ensures that the run off time is comparatively long. Extract recoveries (relative to the laboratory extract) of 98% have been claimed, and 96–97% is usual but in some small breweries the recovery may be as little as 85%. Other disadvantages of mash tuns are their inflexibility with regard to mashing temperatures, their requirement for a coarsely ground grist (with a consequent reduction in extract recovery), the need for well modified malts and the difficulty in using wet, cooked adjuncts.

6.4 Mashing vessels for decoction, double mashing and temperature-programmed infusion mashing systems

In these mashing systems mashes are relatively thin (3.3–5 hl liquor/100 kg grist; 20.48–31 imp. brl/ton) and so they can be stirred and pumped between vessels. While, in principle, the types of vessels have remained constant for a considerable time there have been significant improvements in design and in the designs of the wort separation devices, the lauter tuns and mash filters, used in conjunction with them.

6.4.1 Decoction and double mashing

In the traditional decoction mashing system grist is mashed in using a hydrator and falls into a mash-mixing vessel (Fig. 6.10). To minimize oxygen pick-up the mash may be run down

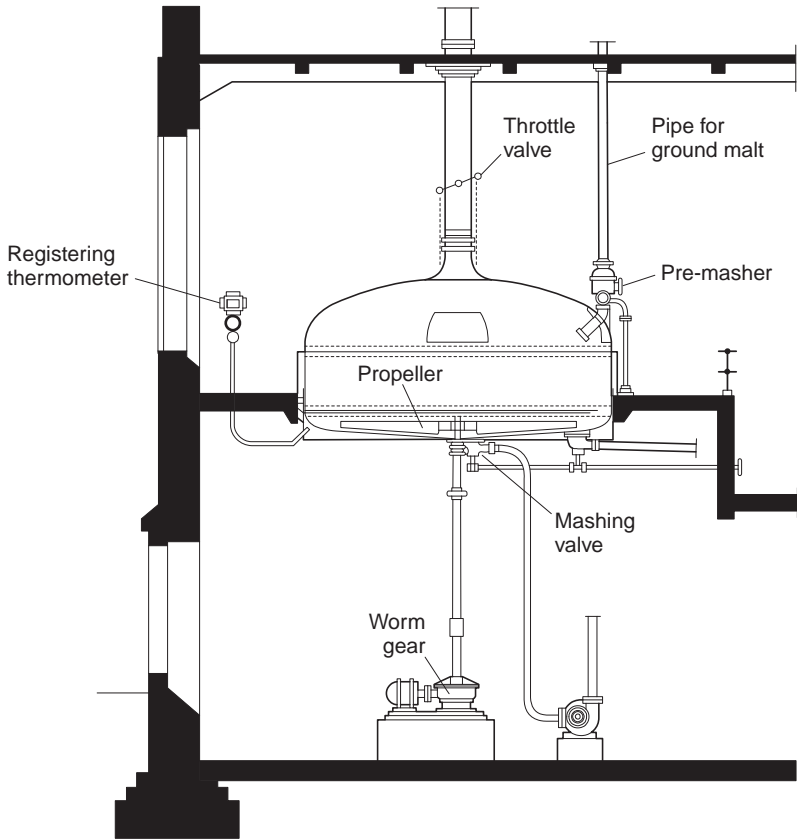

Fig. 6.10 A section of an older pattern of a decoction mash-mixing vessel (after Hind, 1940).

the side of the vessel or pumped into the base. At this stage pH adjustment may be achieved by the addition of a food-grade mineral acid or biologically prepared lactic acid. Acid malt may have been included in the grist to achieve the same effect. Mash is stirred, usually by a propeller in the base of the circular vessel. However, vessels with rectangular cross sections have been used, the contents being mixed by stirrers mounted on long shafts extending downwards from above. The older vessels are often of copper, have a double walled steam heating jacket and are well insulated. Heating may also be by internal steam heated coils or direct steam injection. Low-pressure steam (15 bar, 171 °C, 340 °F) is preferred to superheated water as the heating agent (Wilkinson, 2003). The vessels are covered with copper domes that carry centrally placed flues that carry away steam. In each decoction some of the mash is pumped to a smaller vessel, (the mash cooker, copper or kettle) where it is heated to boiling and then, after a boil, is transferred back to the mash mixing vessel (Chapter 4). These vessels can also be used for cooking adjuncts.

Mash cookers are similar in construction to mash-mixing vessels, except that often stirrers are more powerful and the vessels have relatively greater steam heated areas, since their contents must be heated to boiling. An internally mounted heater may supplement the heating supplied by a steam jacket. In some small breweries the mash cooker also acts as the hop-boiling copper (kettle). Mashing vessels have specified 'duties', for example they must be capable of heating the vessel contents linearly at 0.5 or 1 °C/min. Some decoction mashing breweries, and all breweries using double mashing,

have separate cookers for cooking raw cereal grits. Some may be heated under pressure, and the higher temperatures achieved are a distinct advantage if rice grits are being used. Early cookers were often horizontally mounted, cylindrical vessels closed by rounded ends, heated by a steam jacket and equipped with a helical ribbon stirrer supported by arms extending from a central rotating shaft (Scott, 1967). Newer cookers are generally vertically mounted cylinders closed with a rounded base and cover, heated by a steam jacket and, sometimes, direct steam injection.

6.4.2 Temperature-programmed infusion mashing

Temperature-programmed infusion mashing is less costly than decoction mashing in terms of number of vessels and energy used, decoction mashing needing 20–50% more energy (steam). Estimates of typical energy use levels are, for programmed infusion mashes 8.5 MJ/hl wort, for single decoction mashing 11.0 MJ/hl and for double decoction mashing, 11.6 MJ/hl. Mashing in a mash mixing vessel (with or without a programmed rise in temperature) and separating the wort in a lauter tun or mash filter is a more rapid way of obtaining wort than using a mash tun. The greater speed of processing is achieved because in two-vessel systems a second mash may be in preparation while the first is being lautered or filtered. It is not surprising that brewing practices in mainland Europe and the UK are converging on the use of infusion mash mixing vessels and lauter tuns or mash filters. In addition there has been a convergence in vessel designs, incorporating refinements that confer increased heating efficiency, ease of use, reduction in shear by stirring, flexibility, and reductions in oxygen uptake.

Modern mash mixing vessels, mash cookers, cereal cookers and temperature-programmed mash mixing vessels are very similar. They often have higher height/width ratios than older vessels and commonly have two or three heating zones, allowing different volumes of mash to be heated efficiently (Barnes and Andrews, 1998; Bühler *et al.*, 1995; Herrmann, 1998; Kunze, 1996; McFarlane 1993; Wilkinson, 2001, 2003; Wilkinson and Andrews, 1996; Figs 6.11, 6.12). Probably in all newer vessels stainless steel is the only metal in contact with the mash. Steam jackets were all double walled and later the walls were ‘dimpled’. Now steam is often supplied to the heating surfaces in semi-circular pipes welded onto the heat exchange surfaces (cf. Chapter 10). The turbulence in the steam in the pipes improves its heat transfer efficiency and so the heating performance and, in the event of sudden cooling or other loss of pressure, the heating system is not so liable to collapse under vacuum as are double-walled units. Steam heating is applied to the base of a vessel and to the sides. The side and base heating is applied in zones that are operated separately so only the zone(s) covered with mash are heated. This arrangement allows mashes having different volumes to be processed in one vessel. Sometimes, when direct steam injection is used for heating, the tangential injection of steam helps to mix the mash. Burning on a heat exchange surface cannot occur but steam condensation slightly dilutes the mash, local ‘overheating’, with enzyme destruction, must be a risk and the steam must be ‘pure’ and carry no odorous or other contaminants.

Stirring a mash or transferring it between vessels can create shear which damages the grist, breaking up the particles, extracting more β -glucan and perhaps altering the structure of the particles and making them more gelatinous. One consequence of shear-induced damage is that wort separation is slowed. Modern stirrers create less shear than the older types in which propellers with relatively small diameters turned rapidly. Newer stirrers are larger, extend across about 85% of the vessel diameter, and move more slowly. They cause less shear and create a minimal surface vortex, mix the mash well, and sweep the mash

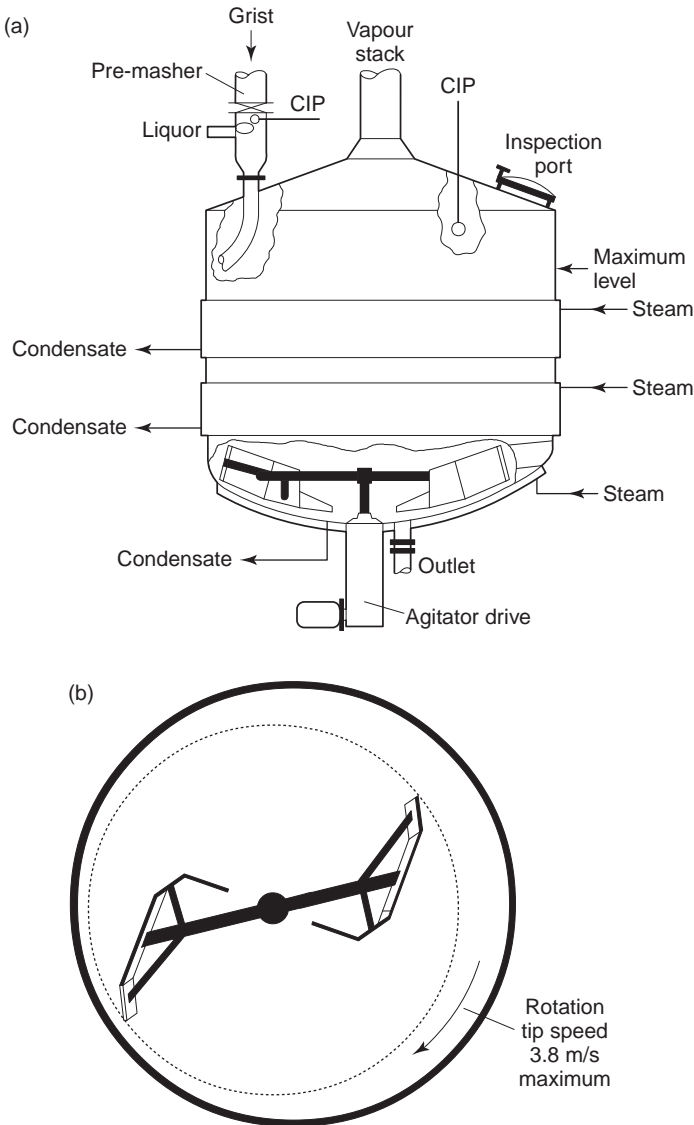

Fig. 6.11 (a) A section of modern mash-mixing vessel. Note the inclined base (after Wilkinson and Andrews, 1996). (b) A plan view of the interior of the base of a mash-mixing vessel, showing the offset stirrer.

over the heat exchange surfaces causing local turbulence so optimizing heat exchange. Scaling and local overheating are minimized and so there is little consequent enzyme destruction and burning on to the heat exchange surfaces (Figs 6.11, 6.12). In some cases the need for baffles (used to prevent the mash rotating with the stirrer, but inevitably causing shear) is overcome by mounting the stirrer off-centre (say 5° from the vertical) in the asymmetrical, dished base of the vessel (Scott, 1967; Wilkinson and Andrews, 1996).

Shear during the transfer of mash between vessels is minimized by using gentle gravity feed where possible or carefully rated, slow-running pumps with wide 'throats' and wide piping, avoiding bends where possible using gentle curved bends where

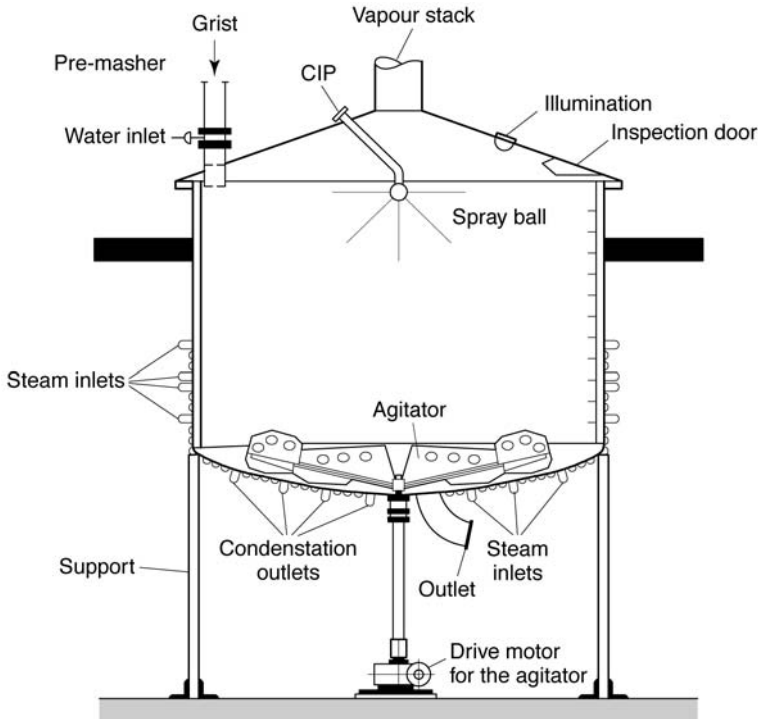

Fig. 6.12 An alternative pattern of mash-mixing vessel (after Narziss and others, 1992).

essential, and minimizing the lengths of pipework. While older stirrers created substantial vortices, which drew air down into the mash, and so favoured oxidations, new stirrers do not, and often they run at a high speed only during mashing in and during heating periods but at a slower speed at other times. Freshly made mash is often delivered to the base of the receiving vessel and rises in the vessel with little turbulence, rather than being dropped from above. Both of these refinements reduce oxygen uptake and so reduce oxidation in the mash. It is less costly to increase the temperature of a mash by adding hot water rather than by heating with steam (Sommer, 1986). Thus at the lower temperature the cooler, thicker mash favours proteolysis while in the hotter, thinner mash, obtained by the addition of hot water, amylolysis is favoured. It is amusing that this 'new' proposal follows the older British practice of underletting with hot water in raked mash tuns. New mashing vessels are now all equipped with the plumbing needed for automated cleaning (CIP). CIP has usually been retro-fitted to older equipment. The steam flues of some mashing vessels, especially mash coppers, may be equipped with economizers to recover heat, as is the case with hop coppers (Chapter 10).

6.5 Lauter tuns

Lauter tuns have been used for many years to separate worts from decoction mashes. Now they are also used with temperature-programmed infusion mashing and double mashing systems. In the UK, in a few instances, lauter tuns have been operated as mash tuns. In recent years the need to accelerate brewing processes, to minimize oxygen uptake

and to improve extract recoveries while obtaining spent grains with lower moisture contents, and to produce equipment to compete with mash filters (Section 6.6) has led to many refinements in the designs and methods of operation of lauter tuns and in improvements in their performances (Andrews and Wilkinson, 1996; De Clerck, 1957; Herrmann *et al.*, 1990; Kunze, 1996; Lenz, 1989; Narziss, 1992; Wilkinson, 1993, 2003). In general layout lauter tuns resemble mash tuns and are usually circular in cross-section (Fig. 6.13), although rectangular lauter tuns have been used. They are covered with domes connected to chimneys that carry away steam, and they are heavily insulated.

There are significant differences between mash tuns and lauter tuns. In particular the grists used in the mashes that are filtered in lauters are more finely ground, the mashes are more dilute, 'thinner', and because more rapid wort filtration is desired the bed depth is comparatively shallow, so it provides a less good filter bed. For a given capacity, a lauter tun may have a 50% greater diameter than a mash tun. The bed depths used are very variable, for example, 35 cm (13.8 in.), and 46 cm (18.1 in.). Maximum bed loadings may be in the range 339–153 kg/m² for cycles allowing 6–12 brews/24 h (Wilkinson, 2003). In the older system mash was dropped into the lauter tun from above through a pipe curved to minimize the impact on the plates and the layer of water covering them. In modern practice the mash is allowed to enter gently through one or more ports either in the sides of the tun or up through the base, to reduce turbulence and the entrainment of air. Possibly the mash may be loaded under a blanket of carbon dioxide gas to exclude air and a top-pressure of carbon dioxide can accelerate wort run off (Stippler *et al.*, 1994).

During transfer to the lauter shear should be minimized, for example, by using a slow-running pump with an open-throated impeller, giving a transfer velocity of less than 1.3 m/s (4.26 ft./s). More entry ports enable loading to be carried out faster, so saving time. The loading that may be used varies with the way in which the grist has been milled. For dry milled grist the loading on the plates may be 160–175 kg/m², for conditioned and milled grist 170–210 kg/m², while for steep-conditioned and milled grist the values are 200–280 or even 310 kg/m² (Kunze, 1996; Lenz, 1989).

The false bottoms were originally made of brass or gun-metal plates, but now are of stainless steel or are substituted by stainless steel, profiled wedge wire (Figs 6.8, 6.9). These plates may be lifted for cleaning, a laborious process that, as with mash tuns, had to be carried out after every run but now, with modern CIP installations, may need to be carried out only weekly or even less frequently. While some plates may have drilled circular perforations, most have slots typically 30–40 mm (about 1.2–1.6 in.) long and 0.6–0.7 mm (0.024–0.028 in.) wide. As with mash tun plates, these slots widen out below. There may be 2500–3000 slots/m² of plate area. Single milled plates may have a free area of 6–8%, double milled plates up to 12% and wedge wire 'plates' of 18% and even up to 25%. The plates provide little resistance to the flow of wort, relative to the resistance provided by the bed of grain, and run off rates are the same with plates of 12 or 18% free area (Lenz, 1989). Run off times may be 1–2 h.

The true bottom of a lauter tun may be flat or consist of a series of depressions or 'valleys' that assist the drainage of wort into the collecting tubes while reducing the under-deck volume, perhaps by 30%. This reduces the volume of hot water needed to cover the plates, the amount of washing water required and hence the volume of effluent. The depth of the under-deck space is usually about 20 mm (0.70 in.). The deeper this space the more water is used in driving out the air, covering the plates and heating the unit, and so the more the initial wort is diluted. The wort collection tubes in the true base may be spaced 1/1.2–1.5 m². The tubes are now usually joined into the base through conical extensions that reduce the local flow rate across the under-deck space and 'even

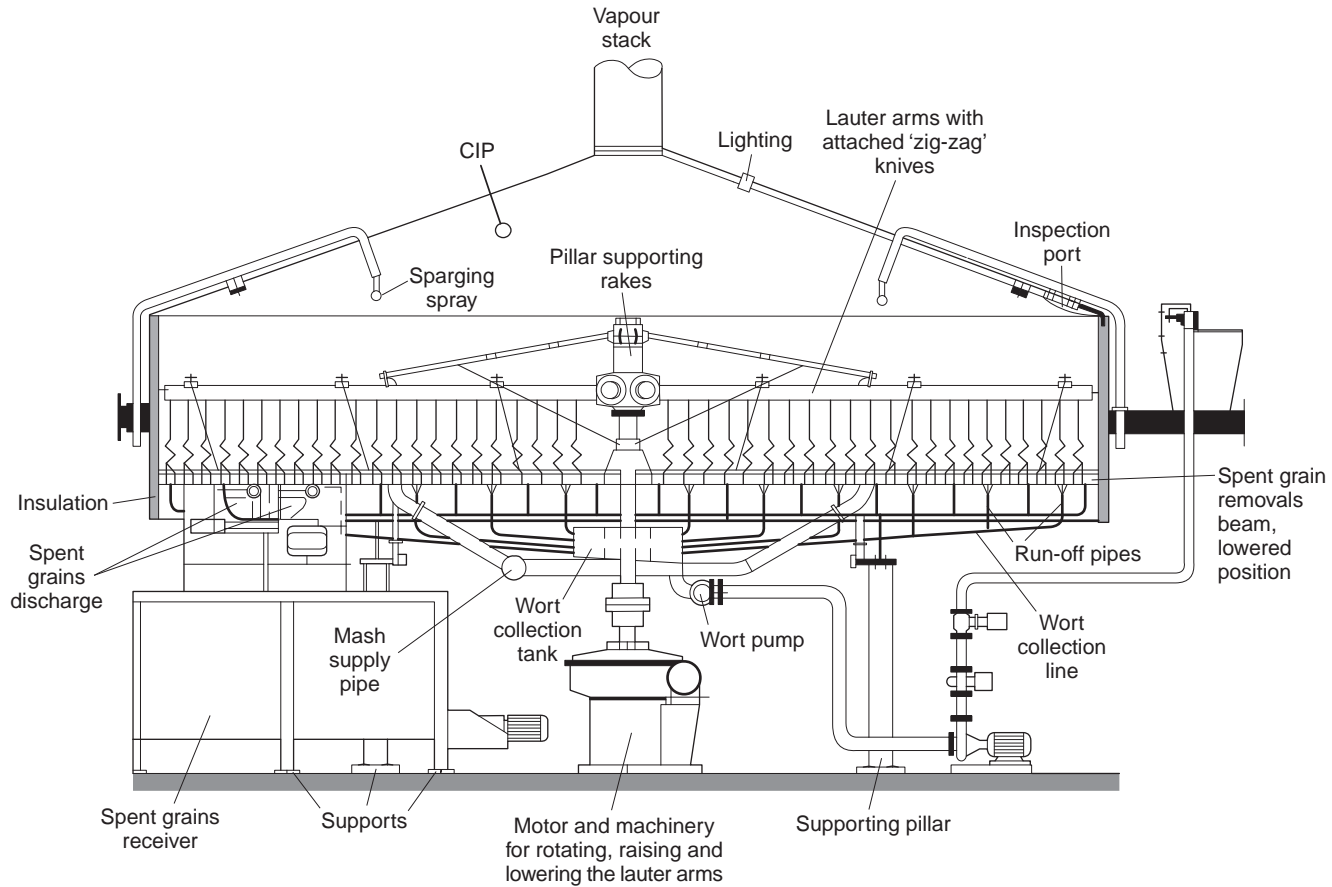

Fig. 6.13 A section of a modern lauter tun equipped with fixed sparging nozzles and zig-zag, chevron-shaped knives, the outer ones of which are the double-shoe type (after Herrmann *et al.*, 1990).

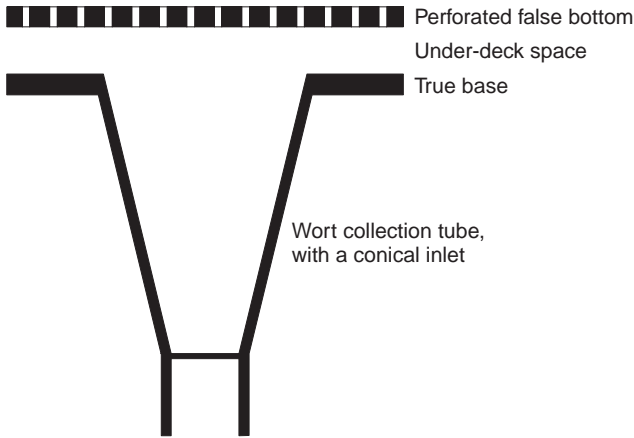

Fig. 6.14 A diagram of a conical entry to a wort collection tube in the base of a lauter tun (after various sources).

out' the suction through the false bottom and on to the bed of grains above (Fig. 6.14). In the past, as with traditional mash tuns, each pipe carried the wort down to a tap with a 'swan neck' that discharged it into a collecting trough or 'grant'. The flow of the wort was regulated by hand and the clarity and gravity was checked. In newer tuns the wort is usually collected in ring mains or directly into a single vessel. These arrangements avoid exposure to the air and are necessary for automated operation.

The mashing machinery consists of rotating beams that carry downwardly directed knives and, often, a sweep arm or 'plough' for removing spent grains. The machinery can be raised or lowered and this is usually automatically controlled. Knives may have 'winglets' which project from the sides. As the knives cut through the mash they lift it slightly because the winglets are angled to the horizontal (Fig. 6.15a), loosening the mash and assisting run off. The bottom of each knife terminates in a 'shoe' which, like the 'winglets' lifts the mash. In some tuns the knives may be rotated through 45–90° so that, as the rotating machinery is lowered into the spent grains at the end of a mash, these are pushed into the freshly opened discharge ports. In some lauter tuns the direction of rotation of the machinery can be reversed and this automatically alters the attitudes of the knives from their cutting to their grain discharging angles. Because of their greater efficiency discharge is increasingly by sweep arms that are lowered into the grain bed in front of the knives (Fig. 6.16). Greater efficiency of grains removal results in less pollution of cleaning water and so smaller effluent charges (Barnes, 2000).

Several other types of knives are in use. Rather than being straight, some have 'zig-zag' blades that cut longer channels in the mash but which, because they are not simple vertical slots, are less likely to encourage channelling with consequent reductions in extract recovery. Another development is the 'double shoe' knife (Fig. 6.15b). Neither of these types lift the mash. In all cases the knives are spaced along the carrier beams so that they travel between the tracks of the other knives, the most efficient arrangement for raking all parts of the grain bed (Fig. 6.17). Knives are arranged so that each cuts the same area of the mash bed. With large lauter tuns this requires special arrangements of the arms supporting the knives (Figure 6.17). Inevitably the further knives are positioned from the centre of the tun the faster they must move through the mash. Sparging liquor may be supplied from rotating overhead sprays, either free or mounted on the beams of the raking machinery, or from fixed overhead ducts. The equipment is washed with hot

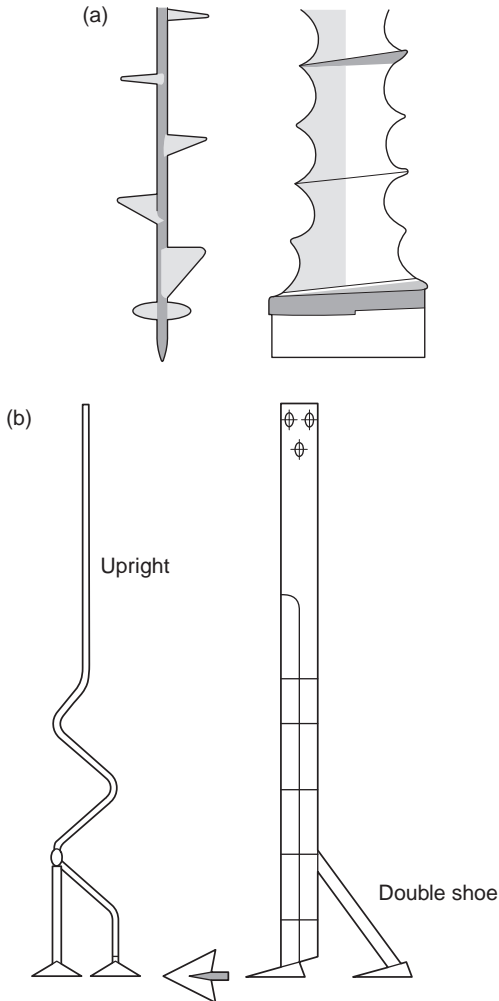

Fig. 6.15 A lauter tun knife equipped with 'winglets' to lift the mash (after Andrews and Wilkinson, 1996). Note the plastic base to the 'shoe' which minimizes the risk of damage to the false bottom of the tun. (b) A pattern of double shoe lauter tun knife with a 'zig-zag', chevron-shaped blade (Lenz, 1989).

water at the end of each run, the false bottom being cleaned with high-pressure jets and the under-deck space being washed with fixed sprays. CIP with strong cleaning solutions may be needed only once a week.

A novel lauter tun has an annular filtration area, the central region being occupied with a cylinder, up through which the shaft carrying the mashing machinery passes (Putman, 2002; Wasmuht *et al.*, 2002). It is argued that extract recovery from the central region of a conventional tun is inadequate, but since extract recoveries of 99.5% have been achieved in such tuns, this claim may be doubted. Many details of this tun have been optimized and are claimed to favour the rapid collection of high-gravity worts.

Lauter tuns are increasingly being automated, but whether operated manually or automatically the stages of an operation cycle are the same. The first operation is to warm the vessel and flood the under-deck space with liquor at the mashing-off and sparging

(a)

Plough bar in rest position

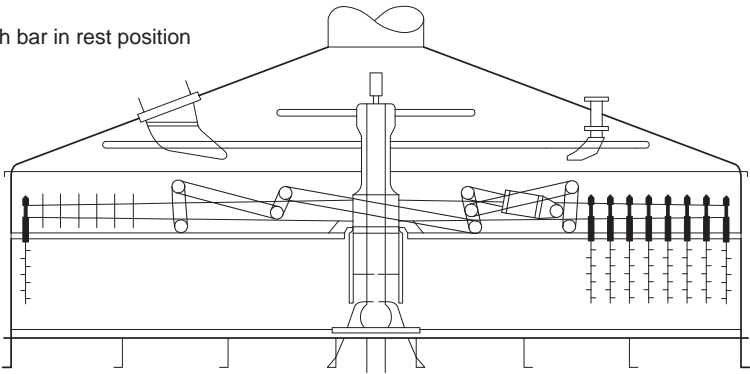

Plough bar in graining-out position

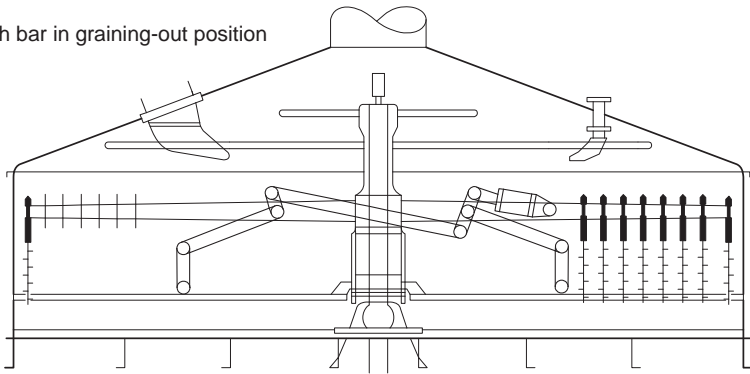

(b)

Grain outlet valves

Spent grains sweep arm

Following sweep arm

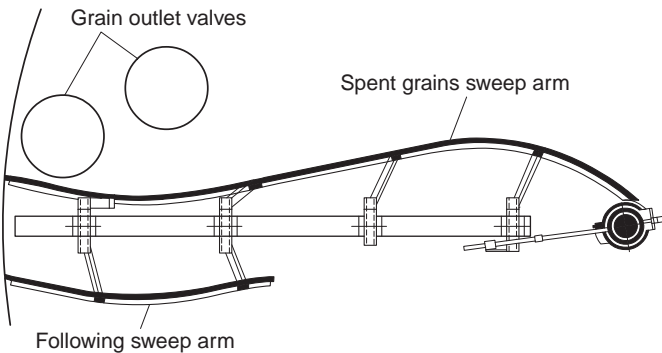

Fig. 6.16 (a) A lauter tun with the grain discharge plough bar in the raised (rest) and lowered (graining-out) working positions (after Barnes, 2000). (b) A plan view of another pattern of grain plough with a trailing, second sweep arm (after Herrmann *et al.*, 1990).

temperature (often 75–78 °C; 167–172.4 °F) to drive out the air and to create a shallow layer of water over the deck (1.2–2.5 cm; 0.5–1 in.) to help spread the mash. The mash is delivered from the mashing vessel, preferably to the sides or up from below, onto the false bottom. In the past loading was from above. The mash must be uniformly well mixed. The delivery period is ‘wasted time’ and so is shortened as far as possible, for example, by using several large delivery ports. The freshly loaded mash may be raked a

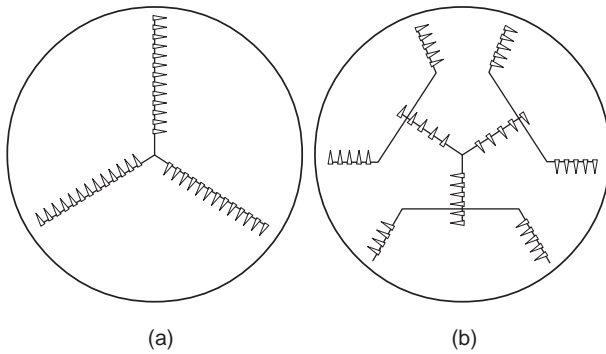

Fig. 6.17 Possible arrangements of knives on the rotating arms in (a) a small lauter tun and (b) a large lauter tun. The knives rotate clockwise and are so spaced along the bars that they track between the slots made by the knives that precede them (Andrews and Wilkinson, 1996).

few times to help ensure even loading and then it is usually (but not invariably) allowed to stand for 5–30 min., when some settling occurs. The first layer to form is the shallow *Unterteig*, about 1 cm (0.39 in.) deep, consisting of comparatively large and dense grits, which are often under-modified, starch-rich fragments of malt. Then the bulk of the grains settles as the *Hauptteig*, and finally a thin layer of very fine particles, the *Oberteig* is formed. This last layer provides a disproportionately large part of the resistance to wort flow and which is first raked or ‘knived’ to accelerate wort collection. Above the settled layer of goods a layer of wort forms. In the past some wort was collected directly from this upper layer, which could usefully be filtered through a 250 μm in-line filter to remove floating particles (Berthold, 2000). This process is now rarely used.

The stirred and water-logged mash does not float (in contrast to an infusion mash in a mash tun). The first wort is withdrawn and, because it carries finely divided materials from beneath the false bottom, it is turbid and so is re-circulated to the top of the mash where it is discharged, preferably under the surface of the liquid to reduce the pick-up of oxygen. The grain bed acts as a filter. When the wort becomes clear, after 5–10 min., the flow is diverted to the copper (kettle) or a collection vessel. In modern practice, designed to speed up lautering, wort re-circulation may begin when about 50% of the mash has been transferred. When a filter layer of spent grains is established and the wort is clear collection begins. The first worts are collected until the surface of the grains appears, then sparging begins. If wort run-off becomes too slow and/or the pressure drop across the bed becomes too high raking will be used, beginning with shallow cuts into the top of the bed, through the *Oberteig*, but with progressively deeper cuts as time passes. If the wort cloudiness increases too much the depth of cutting is reduced. Probably, the continuous application of sparge liquor is usual but intermittent applications (two or three applications of known volumes) may be more efficient at recovering extract. If the mash sets and run-off ceases an underlet and/or sparge may be used, and the mash may be ‘re-slurried’ using the mashing machinery. Sparging may take 2–3 h. but is usually less (Table 6.2).

After wort collection, which is stopped when the wort gravity has fallen to some chosen value, the grains are allowed to drain for about five minutes, to reduce their moisture content. The discharge ports are then opened and the grains are discharged in ten minutes. or less. Efficient and rapid discharge is required, so several large discharge ports may be provided. The drainings and vessel washings contain heat, are rich in suspended solids and have a high COD so they are costly to dispose of as effluent. Furthermore, they contain valuable extract although in dilute solution and of a low

Table 6.2 An example comparison between a mash tun, a lauter tun and a modern mash filter (Geering, 1996)

	Mash tun	Lauter tun (modern, 1996)	2001 Mash filter
Mashing rate (hl/100 kg)	2.8	3.0	2.9
Sparging rate (hl/100 kg)	4.2	3.8	2.4
Total liquor/grist (hl/100 kg)	7.0	6.8	5.3
Filtration area* (m ²)	50	90	708
Bed depth* (m)	0.9–1.2 (2 max.)	0.3–0.5	0.03–0.06
Bed loading* (kg/m ²)	400	160–220	28
Capacity range (% normal)	–60 to +10	–50 to +20	–20 to +10
Initial wort haze (°EBC)	10	> 20	> 20
Average wort haze(°EBC)	4	5–8	< 2
First wort gravity (°Sacch)	80	94	100
Copper gravity (°Sacch)	61	67	70
Lipid content (ppm)	2	18	17
Solids (Imhoff cone, ml/l)	< 8	< 12	< 5
Polyphenols (ppm)	165	180	195
Extract recovery (% lab. extract)	96–97	98–99	102
Moisture draff (%)	81	76	64

* For 20 t mashes.

Mash tun cycle: mash in, 20 min.; stand, 75 min.; run off, 185–330 min.; drain and unload draff, 20 min. Total time, 300–440 min. Lauter tun cycle: underlet, 3 min.; fill, 11 min.; re-circulate first wort, 4 min.; collect first wort, 41 min.; second wort, 74 min.; last wort, 10 min.; weak worts, 16 min.; drain, 8 min.; grains out, 25 min. Total, 192 min. 2001 Mash filter cycle time: filling, 4 min.; filtration, 20 min.; pre-compression, 3 min.; sparging, 46 min.; compression, 8 min.; drain and grains out, 34 min. Total, 115 min.

quality, being relatively poorly fermentable and rich in polyphenols and lipids. This liquid, together with lauter tun rinsings, can be stored hot for short periods and used in the mashing liquor for a subsequent mash, sometimes after a treatment with active charcoal or PVPP. The quantities of solids in the drainings and rinsings should be reduced by ensuring that the grain discharge is thorough, so fewer solids remain to rinse away. It has been suggested that the liquid should be filtered through a 30 μm screen. The possibility of further purification through a 100 nm pore-size, cross-flow membrane filter with consequent reductions in the polyphenols and the virtual elimination of lipids and suspended solids also exists (Barnes, 2000).

The operation of lauter tuns is often fully automated. The flow of wort and its cumulative volume, sparge liquor temperature, volume and flow, wort turbidity (haziness), the pressure differences across the grain bed (between the top of the vessel contents and the under-deck space), and between the under-deck space and the end of the collection pipe or the central collection vessel, and the positions of the knifing machinery (rotating speed, or stationary, height, direction of movement, knife setting, setting of grain discharge plough) are all determined and the measurements are fed to a computer. Increases in the cross-bed pressure instigate deeper cutting into the grain bed while increases in wort turbidity initiate reductions in the depth of cut. Because lautering is often the slowest process stage in wort production, there is a constant pressure to reduce wort separation times. The number of cycles that could be achieved with a lauter tun in 24 hours has risen from six to ten, with 12 being routinely achieved in some instances and even 15 cycles/24 h being claimed. However, for these high rates of use to be achieved low bed loadings must be used.

These rates are dependent on the design of the tun, the nature and grind of the grist being used, as well as the manner in which the mash is carried out and the way in which

the lauter tun is operated. Operating more quickly gives more turbid worts and reduces extract recoveries. The use of inert gases, nitrogen or carbon dioxide, to minimize oxidative deterioration and reduce the oxidation of gel proteins, which contribute to the flow-resistance provided by the *Oberteig*, has been combined, at least experimentally, with the use of gas pressure to accelerate wort run off (Lee *et al.*, 1997; Stippler *et al.*, 1994, 1995; Stippler and Johnstone, 1994). This requires a lauter tun to be fitted with valves and seals to contain the pressure and to prevent an excessive pressure increase or the formation of a vacuum. Pressure-lautering may also give better extract recoveries and spent grains containing less moisture.

6.6 The Strainmaster

The Strainmaster, or Nooter tun, was developed as a compact and exceptionally rapid lautering device in the late 1950s (Irvine, 1985; Narziss, 1992; Vermeylen, 1962). Each unit consisted of a cylindrical or rectangular hopper-bottomed tank, with discharge doors, ‘bomb doors’, in the base. Each tank had seven layers of stainless steel strainer tubes, with pear-shaped cross-sections in the lower half of the vessel. The tubes (130 mm (5.25 in.) high and maximal width 50 mm (about 2 in.)) were perforated with vertical slots, 0.63 mm (0.025 in.) wide and 12.7 mm (0.5 in.) long. Each layer of tubes was connected by a main to a separate wort pump then to separate ‘swan neck’ tubes, which discharged into a grant (Fig. 6.18). The tun was used with a finely milled grist made into a thin mash (2.5 hl/100 kg). After preheating the vessel a mash was delivered through two inlets, which allowed fast and even loading. As each layer of tubes was covered by the mash the appropriate pump was switched on and cloudy wort was drawn off and re-circulated until the grains formed a filter layer on the slots. As soon as the wort ran bright it was directed to the copper. When the mash transfer was complete the continued wort withdrawal caused the volume of the mash to contract. When the volume had declined to

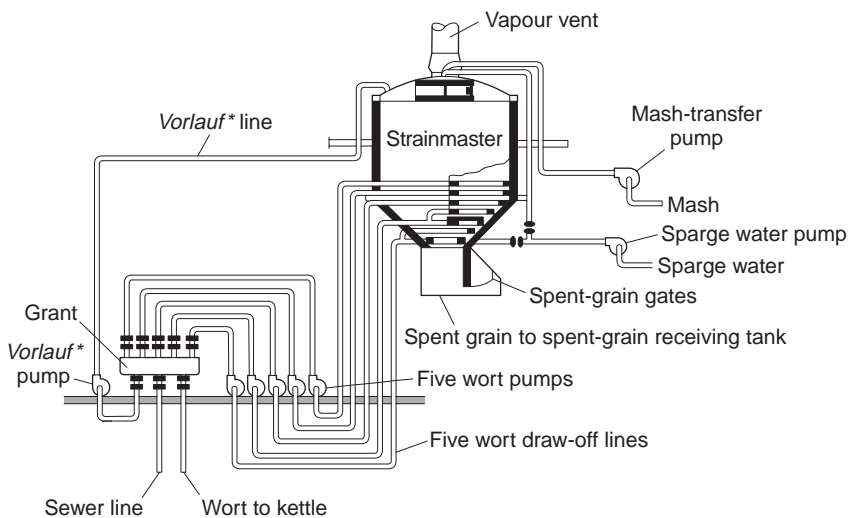

* Vorlauf = first wort (re-circulation)

Fig. 6.18 A Strainmaster lauter tun. The patent is owned by Anheuser-Busch (after Briggs *et al.*, 1981).

a pre-selected value sparging began automatically. When wort collection was complete cold water might be added to the top of the grains, the discharge doors were opened and the spent grains fell and were rinsed into a collecting vessel. Various performance figures were quoted. For example, pre-heating the vessel and transferring the mash (6.8 t) 30–40 min.; run off, 90 min.; grains out, 5 min.; flush, 10 min., total time 135–145 min. Others claimed turn round times of 105 min. at a date (1985) when a lauter tun cycle might be 180 min. The performance of this exceptional device, which created an important benchmark for rapid wort recovery, has now been matched or overtaken. Problems associated with its use included the production of exceptionally wet grains (moisture contents over 80%) which necessitated dewatering with presses or vibrating screens. The press liquor was used to make subsequent mashes. Extract recoveries were generally low, rarely exceeding 96%. Worts were cloudy and effluent loadings were high. The system was not suitable for making high-gravity worts.

6.7 Mash filters

The use of low-pressure mash filter presses was suggested as long ago as 1819, but the first practical experiments were not carried out until 1874, by Galland, and the first commercial press was made by Meura in 1890 (Dixon, 1977). Since that time mash filters have undergone many refinements and, since various types are in use, examples will be described in turn. Filters compete with lauter tuns and so comparisons between these devices will be made. All filters retain the spent grains with filter cloths. Depending on the cloth used the grist can be moderately, finely or very finely ground, permitting better extract recovery. Because the filter layers of grist are thin wort collection is rapid (despite the resistance of the fine grist to liquid flow), and so wort collection times are short.

Traditional filters consist of two types of units (plates and frames), made of iron or stainless steel, suspended alternately along a frame and pressed together when in use (Figs 6.19, 6.20. De Clerck, 1957; Dixon, 1977; Irvine, 1985; Kunze, 1996; Narziss, 1992). The plates from which the wort is collected were originally of grooved iron but these have been replaced by lighter grid plates or folded-sheet plates. The plates have filter cloths draped over them, which provide the support for and retain the mash (Fig. 6.20). In the past cotton cloths were used. These have been replaced by monofilament polypropylene cloths, which last longer (five times or more) and are easier to clean. Thorough cleaning with caustic solutions may be needed only every 800 brews. In contrast, cotton cloths needed cleaning after every brew but gave marginally less cloudy worts. The other units, the frames, are hollow and contain the mash. When the stacks of alternating units, which may be 1.5 m square (4.92 ft. square), are pressed together, often by a hydraulic ram, the gaskets seal between them so that a series of alternating mash-containing and wort-collection chambers are formed and the holes around the edges of the units are joined to form channels for the mash, the sparge liquor and the wort.

Filters may contain around nine tonnes of grist and consist of stacks of 10–60 units. The bed thickness is chosen with reference to the grist to be used, so the finer the grind the narrower the bed. Values of 4–6 cm (1.57–2.36 in.) and even up to 10 cm (3.94 in.) have been used. The end plates are different and seal off channels or provide connections to the mash-delivery and sparge lines. For mash filters to work well, they need to be completely filled and so they should be used with one invariable volume of mash. To reduce the capacity of a filter it is necessary to introduce blanking plates, which is inconvenient and laborious. These older units are made of metal and the heat losses to the

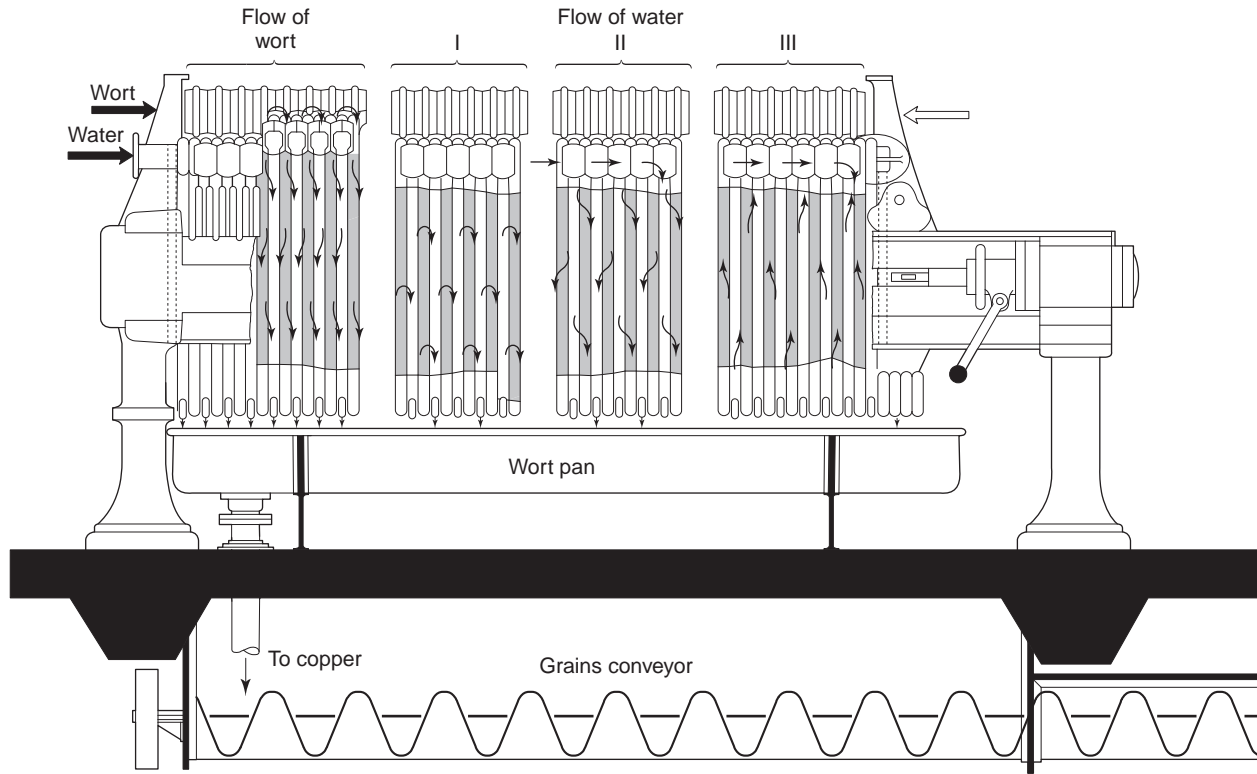

Fig. 6.19 A schematic longitudinal section through an older pattern of mash filter (Hind, 1940).

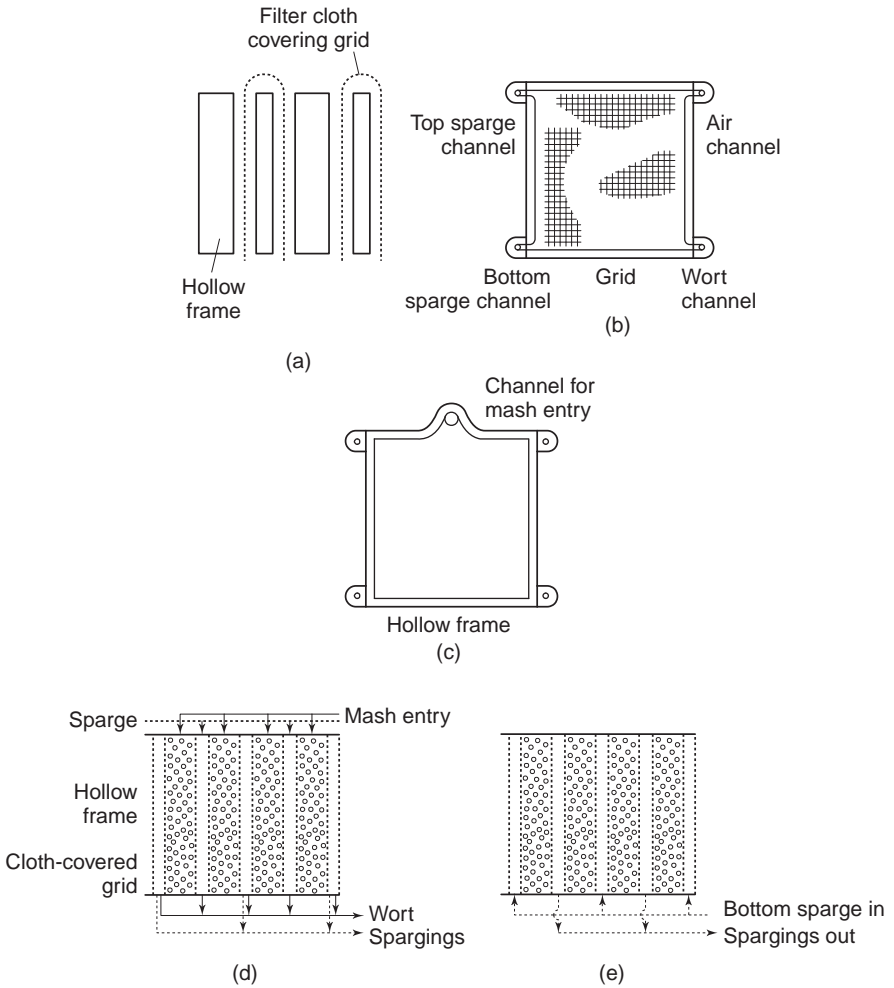

Fig. 6.20 The arrangement of the essential components of a traditional mash filter (Briggs *et al.*, 1981). (a) A vertical section showing how the filter cloths hang over the grids and alternate with the hollow frames, which will contain mash. (b) A face-view of a grid. (c) A face-view of a frame. (d) A stage when the filter is just full of mash and the first worts are escaping (solid lines). The next stage with sparging into odd numbered grids and collecting from even numbered grids (dashed lines). (e) Last stage in sparging.

surroundings are high, the filters are uncomfortably hot to work near and must be mounted in a well-ventilated area. Filters occupy a smaller floor area than lauter tuns of similar capacities. To discharge the spent grains the plates and frames are separated automatically and in turn, when the spent grains fall from the frames and into a collecting trough from which they are moved by a screw conveyor. The opening and grain discharging operations are relatively slow. To halve the time taken ‘double filters’ are used, in which the filters are opened simultaneously from both ends. In operation a filter is preheated to about 80 °C (176 °F) with steam or hot water and is checked for leaks. The filter is emptied and well-mixed mash is pumped from the mashing vessel and is loaded into the frames, from above in older designs, but from below and with minimum turbulence in newer types, to minimize oxygen uptake.

Pre-filling of filters with an inert gas to displace oxygen has been considered. The air or inert gas displaced by the mash is vented. When the frames are full of mash the gas vents are closed while mash is still being transferred into the frames. The taps or outlets from the plates are opened and the wort, which has escaped through the filter cloths, is re-circulated to the mashing vessel until it is clear and then is collected. In older mash filters the flow of wort from each plate was regulated through individual taps leading to swan necks, which delivered the wort into a wort collection trough or grant.

In modern units the wort is collected into a common main and air is excluded. After the first wort has been collected the sparge liquor, which may have been rendered oxygen-free, is admitted into the tops of alternate plates, displacing the wort downwards. When all the wort has been driven out, the wort outlets from these plates are closed while those of the remaining plates are opened. Now the sparge liquor passes from the first plates across through the mash in the frames and out from the second plates. When sparging has been sufficient the last of the sparge liquor is driven through the spent grains by a top pressure provided by compressed air, which also drives out the last of the spargings. The wort emerges at about 75 °C (167 °F). Extract recovery can be as high as 99.5% of the laboratory extract, the first worts are strong (SG 1085–1090) and the final, average values are 1044–1048. Thus filters are useful for high-gravity brewing. The spent grains have moisture contents in the range of 60–80%, usually around 70–75%. The turn around times of these filters is fast enough to allow 8 brews/24h. Sometimes the sequence of production runs must be interrupted for cleaning, which involves rinsing with hot water and treatments with 1–2% caustic soda containing a wetting agent and a chelating agent, such as EDTA, if polypropylene sheets are used.

A novel development is the recessed chamber-plate filter (Nguyen, 1996). These units are made of reinforced polypropylene, and a filter press consists of only this single type of unit, together with appropriate end plates, supported on a frame. Each recessed chamber plate, typically 2.1 m (6.89 ft.) square, consists of a single unit with a recess each side into which the filter cloth fits and is retained by an ‘O-ring’ (Fig. 6.21). Unlike other filters, the cloth does not project from below the units. When the units are assembled the space between the filter cloths is the mash chamber while the spaces between the cloths and the transverse partitions of the plates make up the wort collection chambers and the sparge inlets and outlets. The plates are opened in the usual way to discharge the spent grains which separate from the two filter cloths. The use of an air purge at the end of sparging gives relatively dry spent grains, with < 74% moisture. The worts are concentrated, extract recoveries equal laboratory yields and the cycle time is less than 120 min., permitting 12 cycles/24 h. Like other newer filters made primarily of polypropylene, heat losses are less

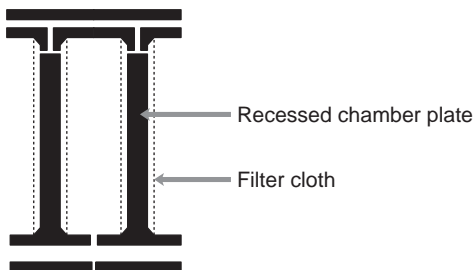

Fig. 6.21 Two recessed chamber plates, seen in vertical section (after Nguyen, 1996). The space between the cloths is the mash chamber. The wort is collected in the spaces between the cloths and the plate partitions.

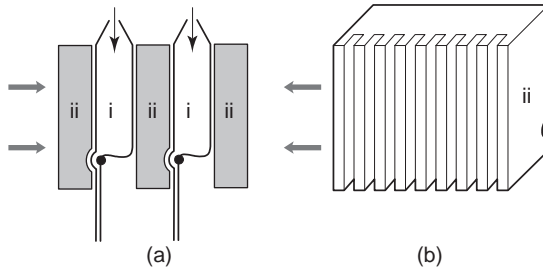

Fig. 6.22 Working diagram of a high-pressure mash filter (Waesburghe, van, 1979, 1989).

(a) Vertical section of part of a filter series in which vertically grooved, stainless steel plates (ii); (b) alternate with the filter pockets (i) which contains the mash. The light arrows indicate the mash loading position. The spent grains were discharged by unsealing the bases of the pockets which are sealed by pressure against the groove on the metal plates. The bold arrows indicate the direction of compression used on the filter assembly.

than those from metal filters, giving more pleasant working conditions and allowing the use of more aggressive cleaning agents without risk of corrosion.

Another device, introduced in 1978 and which enjoyed limited success, is the HP (high-pressure) filter (Waesberghe, van, 1979, 1991; Irvine, 1985; Nguyen, 1996). This filter consisted of a set of polyester or polypropylene filter pockets, which could be opened or closed at the base, alternating with metal plates vertically grooved on one side and with a recess involved with bag closure and sealing on the other (Fig. 6.22). The bags were filled from above and, after a short re-circulation period for clarification, the wort was collected. Because the grists were finely milled the initial worts were bright. The mash was sparged with water added to the tops of the pockets, then the pockets were gently compressed from 7–8 cm (2.76–3.15 in.) thickness and finally squeezed more strongly to 3–4 cm (1.18–1.57 in.). The pockets were then opened and the comparatively dry grains (50–60% moisture) dropped out. Extract recoveries were good, the worts were concentrated and the turn-round time was rapid, about 70 min. These filters did not remain in favour, possibly because of cleaning problems, turbidity in the later ‘squeezed’ worts, difficulties in obtaining even sparging and the complexity of the equipment (Nguyen, 1996).

The newer generation of filters may be termed membrane compression filters. The first of these is the Meura 2001 filter (Eyben *et al.*, 1989; Hermia and Rahier, 1991a, b, 1992; Jones, 1992; Mieleniewski, 1999). The filter is made of alternating chamber modules with membranes and plates, which are covered with filter cloths. Compression and gaskets seal between the units and create the necessary channels for the mash, wort, spargings, etc. The units are made chiefly of reinforced polypropylene and are 2 by 1.8 m (6.56 by 5.91 ft.). The membrane chamber module consists of a thin, grooved plate which supports two elastic membranes or ‘diaphragms’ (of polypropylene and rubber) on each side that can be inflated with compressed air. The space between a membrane and a filter cloth, which holds the mash, is about 4 cm (1.57 in.) wide. The mash is made with a fine, dry hammer-milled or a wet disc-milled grist. A 60-plate filter can accommodate a 10.5 t mash, divided into 120 beds and resting against 60 double filtration cloths. The stages of operation are as follows (Fig. 6.23). The filter is pre-warmed and then mash is pumped into the chambers from below, while the air is vented. This upward delivery minimizes oxygen uptake. When the chambers are full the vents are closed, the wort outlets are opened, wort collection begins and mash delivery is continued until all the mash is in the chambers. During this process a filter-layer of solids quickly builds up on the filter cloth and the wort becomes bright so quickly that re-circulation is rarely needed. The

membranes are then inflated with compressed air, (0.5–0.6 bar; 7–9 psi), and these squeeze the mash, displacing the solids across the chamber and compressing them so that they adhere to the filter cloths and strong wort is squeezed out. Squeezing improves the homogeneity of the bed, as well as making it thinner, and so improves the efficiency of sparging. Before squeezing about 50% of the extract is retained in the grist. After this first compression the membranes are relaxed and the spaces, which appear between them and the grist layers, are filled with sparge liquor (degassed for preference), usually at about 78 °C (172.4 °F).

When sparging is complete the liquor inlets are closed and the mash is compressed a second time, by inflating the membranes with compressed air (0.7 bar; 10 psi), and the last spargings are squeezed out. The plates and frames are automatically separated in turn and the spent grains fall into a receiving trough with a conveyor. Higher air pressures in the last compression give grains with smaller moisture contents, but extremely low moisture contents making the grains difficult to handle and values of 60–70% are probably usual. These filters have rapid turn-round times, allowing 12 cycles/24 h, the worts are strong and extract recovery is exceptional, often 101 and even 103% of the laboratory value (Table 6.2). The fatty acid contents of these worts are very low, 10–24 mg/l for Meura 2001 worts, 27 mg/l for lauter tun worts and even 143 mg/l for filter press worts. It has been claimed that the loading can be reduced to 70% of normal, but practical difficulties have been noted even at loadings reduced to 85% of the standard value. This discrepancy may be due to differences in the grists used. This filter copes well with a wide variety of grists, including those containing mostly unmalted sorghum or roasted and flaked barley. The first and total worts are unusually concentrated, e.g., 14.5 °P (SG 1059) and 11.8 °P (SG 1048) respectively, and so are suited to high-gravity brewing. Filters are cleaned regularly by rinsing and more completely, say weekly, using caustic cleaning agents and possibly hydrogen peroxide. As the filter cloths become dirty the resistance to wort flow increases. As with other polypropylene filters the heat loss is much less than with the older, metal filter presses.

The other membrane filter to be described is the MK 15/20, intended for 5–12.5 t mashes (Karstens, 1996; Kunze, 1996; Michel, 1993). Smaller versions have other reference numbers. The filters consist of alternating membrane and chamber plates, mostly made of polypropylene. Filter cloths are firmly fastened over both sides of both kinds of plates (Fig. 6.24). When the units are assembled and pressed together the edges of the cloths seal (replacing gaskets) and create mash chambers bounded on both sides by filter cloths, so wort can escape from both sides of the mash. The sequence of operations is indicated in Fig. 6.24. The mash cycle time is about 120 min.

6.8 The choice of mashing and wort separation systems

The choice of mashing system depends on many factors. For the production of traditional beers it may be imperative to continue using near-isothermal mashing in a mash tun or decoction mashing to retain the character of a product. In the same way, a particular fermentation system may have to be retained. For small traditional breweries making ales a mash tun, with its simple construction and low maintenance requirements, serves well if not more than two to three brews every 24 hours are required. For larger breweries, making large volumes of single beers, the economic advantages of using all the brewing equipment for as much of the week as possible, and making as many brews every 24 hours as possible are very great. Because both conversion and wort separation occur in

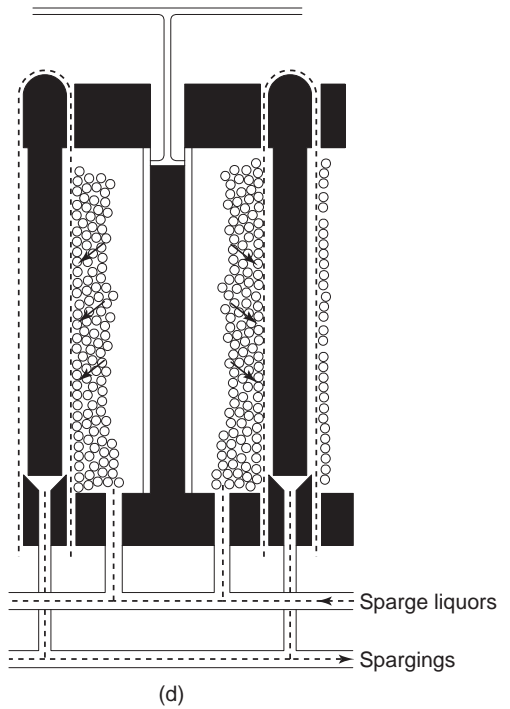
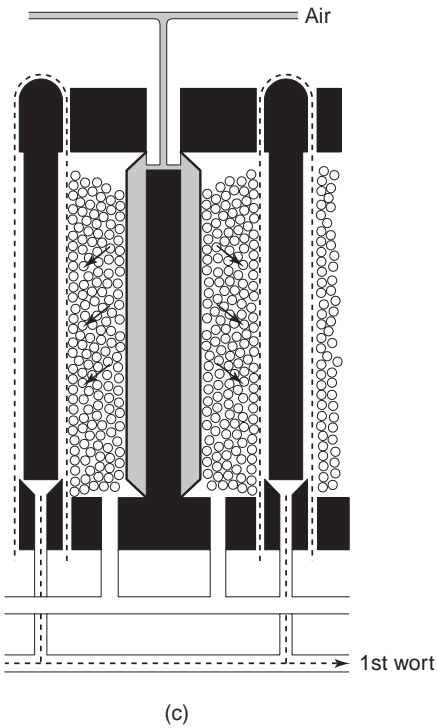
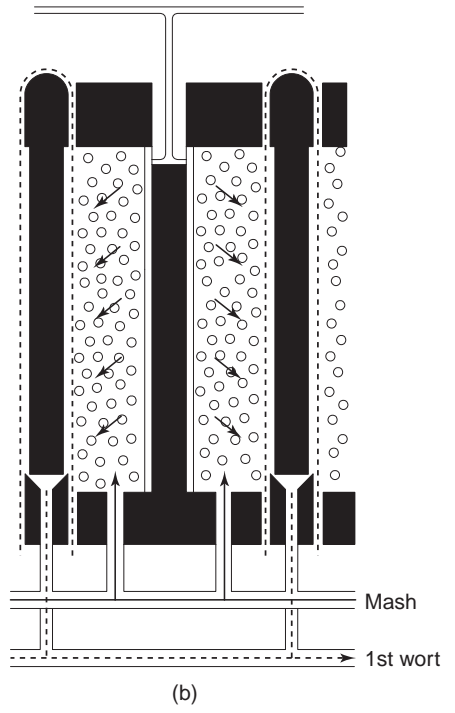
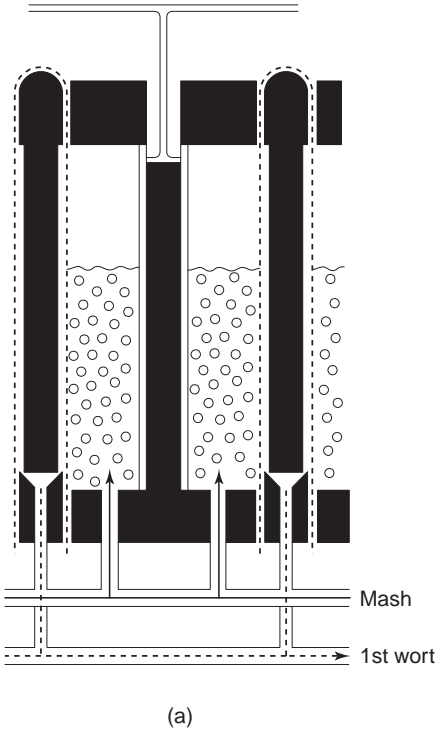

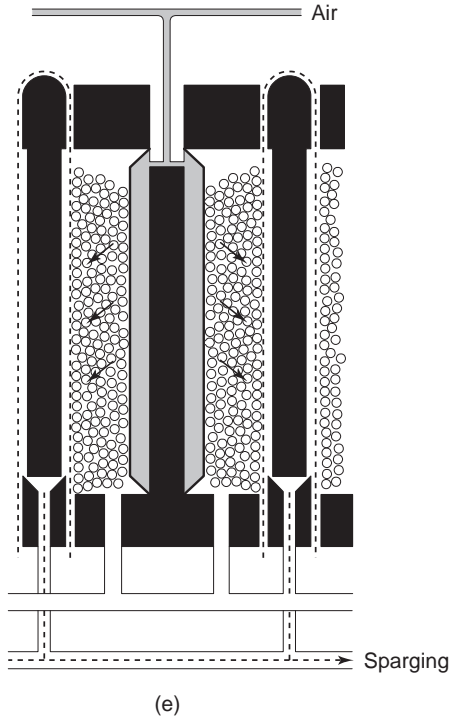

Fig. 6.23 Stages in the operation of a Meura 2001 membrane mash filter (various sources). (a) The mash being loaded into the frames from below the membrane and the filter cloth. Air is being expelled at the top. (b) All the air has been expelled, the vents have been closed, mash is still being pumped into the filter and the first wort is escaping through the filter cloth and is being collected. (c) All the mash has been transferred into the filter, the inlet lines are closed and compressed air has been directed behind the membranes, pushing them out and causing them to squeeze the mash, releasing entrained first wort. (d) Sparge liquor has been admitted between the deflated membrane and the compressed mash and the first spargings are being collected. (e) The membranes have been inflated for the second time, to squeeze the spargings from the draff. In the next stage the filter is opened and the spent grains fall into a collection trough and are conveyed away.

the single vessel in a mash tun and the depth of the bed of grist is large, the turn round time is slow. Some decoction mashing schedules are slow (Chapter 4), but with temperature-programmed infusion mashing with an all-malt grist conversion should be complete in two hours, or less, and wort separation may be completed sufficiently quickly to readily allow 8–10 (and possibly 12) brews/24 h with a lauter tun and 10–12 brews/24 h. with a new mash filter.

Both lauter tuns and mash filters can produce high-quality worts (Table 6.2). A mash filter using hammer milled grist will give a better extract recovery, a more concentrated wort, drier spent grains, use less water and generate less effluent, but is likely to be more costly than a lauter tun of equivalent capacity. If the brewery is making a variety of beers that necessitate the use of different brew lengths then the greater flexibility of the lauter tun becomes decisively important. Furthermore, the use of a comparatively coarsely ground grist, suited to a lauter tun, may be needed to retain the character of a particular beer. Lauter tuns are likely to be less expensive than newer types of mash filters and require less maintenance and fewer replacements. The operations of both are now usually automated. Flexibility may be increased by having mash conversion vessels of different

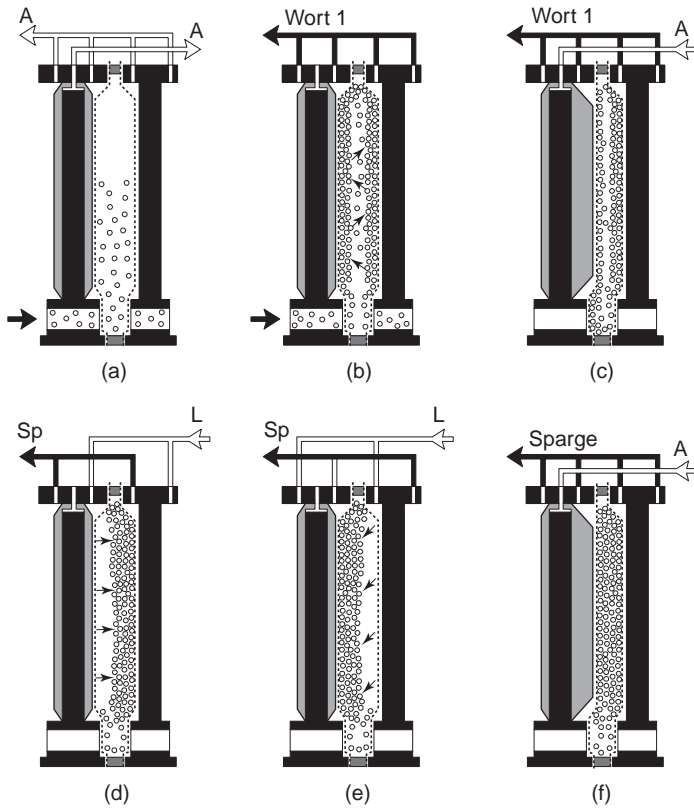

Fig. 6.24 The operational stages of an MK 15/20 filter (various sources). (a) Mash is added at the base and rises between the two filter cloths, and air is displaced, A. (b) All the air has been displaced, the vents are closed and mash entry continues. Layers of grain build up on the filter cloths and escaping wort is collected. (c) Compressed air, A, inflates the membranes and compresses the mash. The displaced wort is collected. (d) Sparge liquor, Sp, is admitted and the spargings, Sp, are collected. (e) Possible sparging between the two filter cloths, but in the reverse direction. (f) At the end of sparging the grist is squeezed again and the displaced spargings are collected. At the end of this sequence the filter is opened and the draff falls into a collecting trough.

capacities and the choice of using either one of two wort separation units (Mieleniewski, 1999). Alternatively, when slow mash conversions occur, for example because relatively high concentrations of slow-converting mash adjuncts are used, two mash conversion vessels may alternately deliver mash to a single wort separation unit. It is apparent that for optimal working all the components used in the preparation of wort, raw materials handling, milling and grist handling, mashing/conversion, sweet wort separation, hop-boiling, trub separation, wort cooling and fermentation must have the appropriate capacities and working rates to avoid ‘bottlenecks’ and permit fast working at periods of maximum demand.

6.9 Other methods of wort separation and mashing

Various unusual methods of wort separation have been tested (Briggs *et al.*, 1981; Lotz *et al.*, 1997; Dixon, 1977; Béndek *et al.*, 1991; Darling, 1968; Schneider *et al.*, 2001;

Schöffel and Deublein, 1980). With the proposed dynamic disc mash filtration technique the rotating disc drives the mash tangentially to the filtration surface and the wort is membrane filtered. In the Pablo system the wort is separated from the mash with two, double stage decanting centrifuges, in the Reiter system a rotary vacuum filter is used and gives a high extract recovery. Other devices tried include vibrating screen filters, vibrating membrane filters, horizontal and inclined belt filters, with or without suction, cross-flow filters, Archimedean screws working in slotted casings and cyclones. Many of these methods were intended to be used with fractionated malt grists lacking husk materials so that relatively little draff would remain after the conversion process. Some were used for short periods but many did not pass beyond the experimental stage.

During the period 1955 to 1975 there was intense interest in continuous brewing, with its advantages of relatively compact, continuously operating equipment with its steady demand for services and its predicted uniform product quality. Large production plants were constructed and used but many problems were encountered that led to them being replaced by batch production units. At the present time continuous fermentation is carried out on an industrial scale by only one company in New Zealand (Chapter 14) and this is not linked to continuous wort production. However, there is a revival of interest in continuous fermentation and conditioning using immobilized yeasts and this may lead back to an interest in continuous mashing, since processing is most advantageous when all stages are continuous (Briggs *et al.*, 1981; Darling, 1968). Perhaps the most promising continuous mashing system was the rotary table filter proposed by APV (Fig. 6.25). In this equipment the mash travelled, in sequence in plug flow, through stainless steel tubes

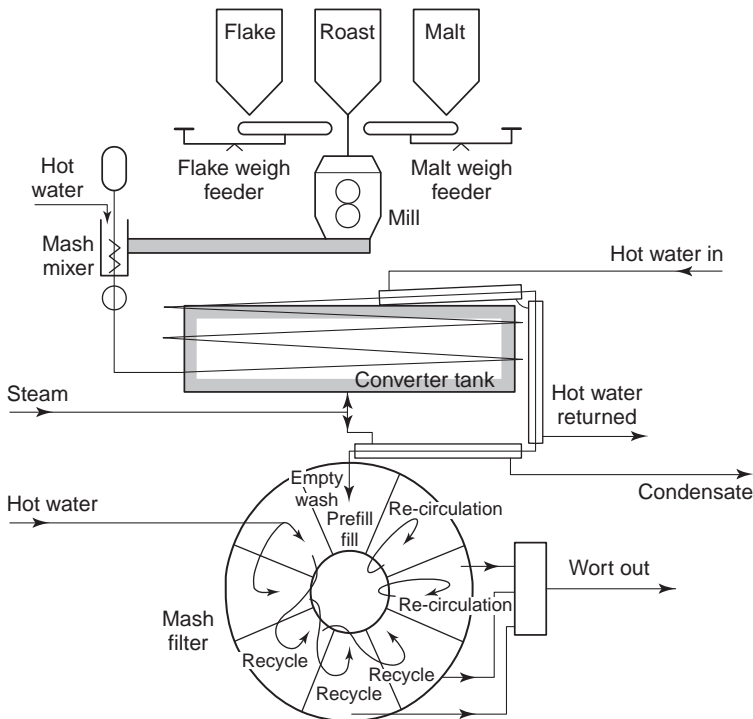

Fig. 6.25 A diagram of the A. P. V. continuous mashing and lautering system (Briggs *et al.*, 1981).

held in 'converter tank(s)' at the chosen mashing temperature(s). The converted mash was loaded into one of eight mash buckets, each of which resembled a small mash tun. For two hours a tun moved around a central support, occupying each of 16 positions in turn, for 15 min. The positions were used for filling, wort recycling, collection and sparging, spent grain discharge and cleaning, then return to the filling position.

6.10 Spent grains

The undesirable characteristics of mash and spent grain drainings as effluents, with their high COD, BOD and suspended solids values, have been noted (Chapter 3), as has the nutritional value of draff in animal feeds (Chapter 4). It is best for the brewer and the user that the draff is reasonably dry and certainly not seeping liquid. Drier draff reflects better extract recovery for the brewer and smaller transport costs and storage problems for the user. The wet state of the draff from Strainmasters was a major factor in replacing them with other equipment. Conversely, the low moisture content of the draff from mash filters is a factor in their favour. The production of dry draff becomes even more important where local conditions dictate that it must be thoroughly dried. Drying is an expensive process. Spent grains are usually moved by helical screw or compressed air conveyors to storage bins which typically discharge their contents directly into lorries. This area of the brewery must be regularly cleaned, since many microbes multiply on wet grains and drainings, so these represent potential sources of contamination and product spoilage.

6.11 Theory of wort separation

The theories applied to wort separation have been considered and have been of value in designing new equipment (lauter tuns and mash filters) but they apply to 'ideal' situations while, in practice, the conditions are often far from perfect (Briggs *et al.*, 1981; Dixon, 1977; Harris, 1968, 1971; Hermia and Rahie, 1992; Royston, 1966; Wilkinson, 2001). The modified Darcy's equation (originally derived from the passage of water through beds of sand) may be written:

$$V = K A \Delta P / L \eta$$

where V is the rate of liquid flow through the bed of particles, A is the area of the bed, ΔP is the pressure difference across the bed, K is the permeability of the bed, L is the length of the path through the bed, or the bed depth, and η is the viscosity of the liquid. K , the mash bed permeability, $= \gamma^3 de^2 / 180(1-\gamma)^2$, where γ = bed porosity (wort volume/mash volume) and de = effective particle diameter (sum of the weight fraction/particle diameter). In a mash the viscosity will depend on the concentration and nature of the wort and the temperature. The use of adjuncts that give viscous worts creates run-off problems. The porosity of the bed is more important than that of the support, the false bottom of a mash or lauter tun or the clean filter cloth of a mash filter, and is proportional to the mean diameter squared of the grist particles. Thus the finer the grind of the grist, the smaller the particles and the greater the resistance to flow.

The particle shape is also important. The faster flow of lauter tuns relative to mash tuns is achieved (despite the finer grists used) by reducing L , the bed depth, and this process is carried further in mash filters. While increasing the pressure can increase the rate of wort flow this approach can be counter-productive since the mash beds are far

from ideal and can be compressed to such an extent that flow is reduced or even ceases and a 'set mash' is created. As wort separation proceeds so the bed of grains builds up to a maximum thickness, L , and may then decrease as the bed contracts or is compressed. After the first wort is collected and sparging begins wort concentration and hence its viscosity, falls. Similar conclusions can be drawn from modifications of Poiseuille's equation, derived to describe the flow of liquids through bundles of equal sized capillaries, in which the diameter of the capillaries is replaced by the mean diameter of the pores in the bed (or the related value of 'voidage'). The flow through the bed is proportional to the square of the mean diameter of the pores.

As sparge liquor moves into the bed of grist it displaces the wort from between the particles and leaches extract from within them. Efficient leaching is essential if high yields of extract are to be obtained. The solid phase mass transfer coefficient, $K \propto D/d$ where D is the diffusion coefficient and d is the diameter of the particle. Thus, the smaller the particle the greater the surface/volume ratio and the shorter the distances from points within the particle to the surface and the faster extract can be leached from it. Diffusion occurs faster at higher temperatures but sparging temperatures are limited to about 78 °C (172.4 °F) by other considerations. Leaching takes time and sparging too rapidly results in inadequate leaching and a reduced recovery of extract. Since leaching is favoured by a finely ground grist while flow rate is favoured by larger particles, in practice, a compromise grist particle size must be sought for each type of wort separation equipment. The more brews/day that are required the lower the loading on a lauter tun must be. For example, for total cycle times of 240, 180 and 120 min. a lauter tun, using all malt grists, had loadings (kg/m^2) of 339, 246 and 153 respectively (Wilkinson, 2001).

During the movement of sparge water through the mash bed there is a progressive leaching of soluble substances from within the particles and a gradient of wort concentration is established, which increases downwards through the bed. The theoretical stages are, firstly, the diffusion of extract from the interiors to the surfaces of the grist particles and, secondly, the movement of the extract into the liquid between the particles and its removal with this flowing liquid. Leaching has been approximately described by equations based on the number of theoretical washing stages involved (Table 6.3). More washing stages are required to minimize losses in the preparation of strong worts. Greater retention of liquor in the spent grains leads to greater losses of extract and the need for more extensive washing. The 'squeezes' applied in operating membrane mash filters reduce, firstly, the amount of strong wort and, secondly, the amount of spargings in the draff and so enhance extract recovery. As grain beds become more free running so the washing efficiency decreases and there is a tendency for extract recovery to decline. It follows that increasing the rate of sparging carries with it the risk of a significant fall in extract recovery. As previously noted with some plant, like the Strainmaster, the losses of extract in wet spent grains can be so high that it is desirable to recover the extract from the grain pressings, with the extra cost and effort involved and the risk of reducing product quality.

Another process that occurs during wort separation is the filtration of the fine particles from the wort. It is desirable that the wort be as bright as possible. The nature and abundance of these particles depend on many factors. The large bed depths used in mash tuns ensure that, combined with wort re-circulation, very clear worts can be obtained. Generally lauter tuns give less clear worts, in part because of the need to 'knife' or 'rake' the bed to maintain an acceptable rate of run off. Older, 'classical' mash filters gave rise to even more hazy worts but the newer, membrane compression mash filters give rise to exceptionally clear worts. This sequence seems to be the result of a several conflicting

Table 6.3 Theoretical losses in yield (%) in the extraction of a thick mash made with a liquor/grist ratio of 2 : 1 (wt/wt; Royston, 1996)

Spent grains moisture contents (%)	For a wort of SG 1050 (12.4°P)						For a wort of SG 1100 (23.7°P)					
	First worts	Washing stages					First worts	Washing stages				
		1	2	3	4	5		1	2	3	4	5
87	22	6	1.5	0.5	0.1	0.1	40	18	11	8	6	4
75	12	2	0.4	0.1	0.1	0.1	25	11	6	4	3	2
60	7	0.7	0.1	0.1	0.1	0.1	15	5	3	1.5	0.8	0.5

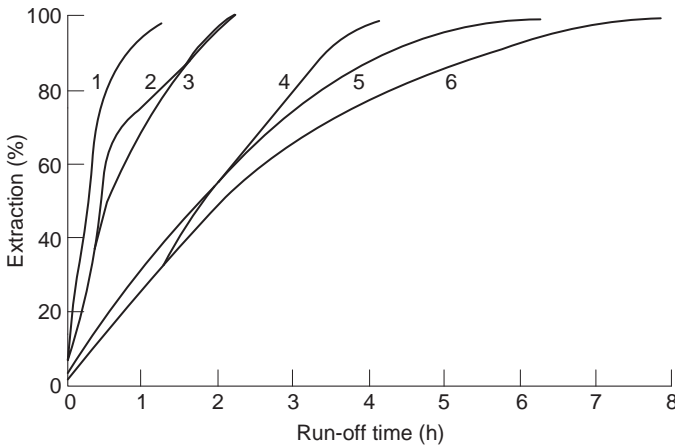

Fig. 6.26 The patterns of the cumulative extract recovery against wort filtration time for various systems (Harris, 1968). (1) A Strainmaster lautering vessel. (2) A lauter tun loaded with a decoction mash. (3) A lauter tun loaded with a transferred infusion mash. (4) A mash tun with a medium depth of mash (1.52 m; 5 ft.). (5) A mash tun with a deep mash bed (2.44 m; 8 ft.). (6) A mash tun with a deep bed of grist containing both malt and maize grits, which slow wort separation.

traits, that thicker beds make better filters, more fines are formed with finer grinding and exceptionally finely ground (hammer milled) grists are able to retain very fine suspended materials, presumably because the mean pore sizes through the beds are very small. The haziness of worts is also influenced by the grist composition and is probably increased by attempts to collect worts too fast, at rates that exceed the optima of the different pieces of equipment.

Figure 6.26 illustrates the progressions of recovery of extract during wort run off from several types of separation devices. The rates are Strainmaster > lauter tun > mash tuns. Thus, as predicted, the larger the filtration area /unit mash the faster extract collection. Wort recovery from the mash tun with medium depth and an all-malt grist is complete (97% extract recovery) in 255 min., while the values with the deeper tuns, with malt and malt and maize grits, (98% extract recovery) are 330 and 400 min. The performance (true filtration efficiency) of the Stainmaster and the lauter tuns was not as great as predicted on theoretical grounds, possibly because, at least in part, the mash beds were compressed (Harris, 1971).

6.12 References

- ANDREWS, J. M. H. and WILKINSON, N. R. (1996) *Ferment*, **9**(5), 257.
 BARNES, Z. C. (2000) *Ferment*, **13**(1), 27.
 BARNES Z. C. and ANDREWS, J. M. H. (1998) *Proc. 5th Aviemore Conf., Malting, Brewing and Distilling* (Campbell, I. ed.). London, The Institute of Brewing, p. 127.
 BÉNDEK, G., HORVÁTH, I. and ULLMANN, P. (1991) *Proc. 23rd Congr. Eur. Brew. Conv., Lisbon*, p. 633.
 BERTHOLD, U. (2000) *Proc. 26th Conv. Inst. of Brewing (Asia Pacific Section), Singapore*, p. 52.
 BRIGGS, D. E., HOUGH, J. S., STEVENS, R. and YOUNG, T. W. (1981) *Malting and Brewing Science* (2nd edn), *Vol. 1 Malt and Sweet Wort*. London, Chapman and Hall, 387 pp.
 BROWN, H. T. (1910) *J. Inst. Brewing*, **16**, 112.
 BÜHLER, T. M., MATZNER, G. and McKECKNIE, M. T. (1995) *Proc. 25th Congr. Eur. Brew. Conv., Brussels*, p. 293.
 DARLING, R. O. (1968) *Brewers' Guard.*, Apr., p. 147.

- DE CLERCK, J. (1957) *A Textbook of Brewing, vol. 1.* (Trans. Barton-Wright, K.). London, Chapman and Hall, 587 pp.
- DIXON, I. (1977) *Brewers' Guard.*, **106**(10), 43.
- EYBEN, D., HERMIA, J., MEURENS, J., RAHIER, G. and TIGEL, R. (1989). *Proc. 22nd Congr. Eur. Brew. Conv., Zurich*, p. 275.
- GEERING, P. (1996) *Brewers' Guard.*, **125**(10), 32.
- HARRIS, J. O. (1968) *J. Inst. Brewing.*, **74**, 500.
- HARRIS, J. O. (1971) in *Modern Brewing Technology* (Findlay, W. P. K. ed.). London, MacMillan Press, p. 1.
- HERRMANN, H. (1998) *Ferment.*, **11**(1), 36.
- HERRMANN, H., KANTELBURG, B. and LENZ, B. (1990) *Brauwelt Internat.*, (1), 22.
- HERMIA, J. and RAHIER, G. (1991a) *Louvain Brew. Lett.*, **4**(3/4), 30.
- HERMIA, J. and RAHIER, G. (1991b) *Louvain Brew. Lett.*, **4**(2), 24.
- HERMIA, J. and RAHIER, G. (1992) *Ferment.*, **5**(4), 280.
- HIND, H. L. (1940) *Brewing Science and Practice. Vol. II. Brewing Processes.* London, Chapman and Hall, pp. 507–1020.
- HOPKINS, R. H. and CARTER, W. A. (1933) *J. Inst. Brewing.*, **39**, 59.
- IRVINE, J. A. (1985) *The Brewer*, Feb., p. 46.
- JONES, I. R. (1992) *Brewers' Guard.*, **121**(10), 21.
- KARSTENS, W. (1996) *Brauwelt Internat.*, **14**(4), 340.
- KUNZE, W. (1996) *Technology Brewing and Malting.* (Wainwright, T., transl.). Berlin, VLB, pp. 726.
- LEE, B. W., KIM, I. K. and SHIN, J. Y. (1997) *MBAA Tech. Quart.*, **34**(2), 75.
- LENZ, B. (1989) *Proc. 2nd Sci. Tech. Conv. Inst. of Brewing (Central and Southern African Sect.)*, Johannesburg, p. 250.
- LOTZ, M., SCHNEIDER, J., WEISSER, H., KROTTENTHALER, M. and BACK, W. (1997) *Proc. 26th Congr. Eur. Brew. Conv., Maastricht*, p. 299.
- McFARLANE, I. K. (1993) *Ferment.*, **6**(3), 177.
- MICHEL, R. (1993) *Brauwelt Internat.*, (2), 123.
- MIELENIOWSKI, A. (1999) *Brew. Distill. Internat.*, **30**(3), 12.
- NARZISS, L. (1992) *Die Bierbrauerei, Bd. II. Die Technologie der Würzbereitung.* (7th edn). Stuttgart, Ferdinand Enke, 402 pp.
- NGUYEN, M. T. (1996) *Ferment.*, **9**(6), 329.
- PUTMAN, R. (2002) *Brewer Internat.*, **2**(10), 4.
- REHBERGER, A. J. and LUTHER, G. E. (1994) in *Handbook of Brewing*, (Hardwick, W. A. ed.). New York, Marcel Dekker, p. 247.
- ROYSTON, M. G. (1966) *J. Inst. Brewing.*, **72**, 351.
- SAMBROOK, P. (1996) *Country House Brewing in England, 1500–1900.* London, The Hambledon Press, p. 311.
- SCHNEIDER, J., KROTTENTHALER, M., BACK, W. and WEISSER, H. (2001) *Proc. 28th Congr. Eur. Brew. Conv., Brussels*, CD, paper 22.
- SCHÖFFEL, F. and DEUBLEIN, D. (1980) *Brauwissenschaft*, **33**(10, 11), 263, 304.
- SCOTT, P. McM. (1967) *Brewer's Guild J.*, p. 339.
- SOMMER, G. (1986) *Brauwelt Internat.*, (1), 23.
- STIPLER, K. and JOHNSTONE, J. (1994) *Brew. Distill. Internat.*, Apr., **25**, 26.
- STIPLER, K., WASMUHT, K., PRITSCHER, R. and KEIM, N. (1994) *Proc. 23rd Conv. Inst. of Brewing (Asia Pacific Sect.)*, Sydney, p. 56.
- STIPLER, K., WASMUHT, H., PRITSCHER, R. and KEIM, N. (1995) *MBAA Tech. Quart.*, **32**(1), 1.
- SYKES, W. J. and LING, A. R. (1907) *The Principles and Practice of Brewing* (3rd edn) London, Charles Griffin and Co., 588 pp.
- VERMEYLEN, J. (1962) *Traité de la Fabrication du Malt et de la Bière. 2.* Gand. Assoc. Royale des Anciens Elèves del'Institut Supérieur des Fermentations, pp. 751–1624.
- WAESBERGHE, J. W. M. VAN (1979) *Brew. Distill. Internat.*, **9**(9), 54.
- WAESBERGHE, J. W. M. VAN (1989) *MBAA Tech. Quart.*, **17**(2), 66.
- WAESBERGHE, I. R. J. VAN (1991) *Proc. 3rd Sci. Tech. Conv. Inst. of Brewing (Central and Southern African Section)*, Victoria Falls, p. 96.
- WASMUHT, K., STIPLER, K. and WEINZIERL, M. (2002) *Brauwelt Internat.*, **20**(5), 286.
- WILKINSON, N. R. (1993) *Brew. Distill. Internat.*, May, **24**, 12.
- WILKINSON, N. R. (2001) *Brewers' Guard.*, **130**(4), 29; (5), 22.
- WILKINSON, N. R. (2003) *Brewers' Guard.*, **132**(2), 24; (3), 20.
- WILKINSON, N. R. and ANDREWS, J. M. K. (1996) *Ferment.*, **9**(4), 215.
- YAMAGUCHI, I., UEDA, T., UJIHARA, S., YAMADA, M. and FUKUSHIMA, S. (1997) *Proc. 26th Congr. Eur. Brew. Conv., Maastricht*, p. 257.

Hops

7.1 Introduction

Medieval ale (unhopped beer) rapidly went sour and turned into malt vinegar. Many herbs were used in attempts to prolong the shelf-life of such ale (Johnstone, 1997; Behre, 1999) but only the hop, *Humulus lupulus* L., is used in large-scale brewing today although some microbreweries use other herbs. Detailed information about hops is found in a book by Neve (1991) and an earlier book by Burgess (1964). A booklet, *Hops and Hop Picking*, by Filmer (1982) gives many illustrations. The European Brewery Convention has published a *Manual of Good Practice – Hops and Hop Products* (Benitez *et al.*, 1997) and the Proceedings of two symposia on Hops (European Brewery Convention, 1987 and 1994). Moir (2000) provided a millennium review. Hops are grown throughout the world, as illustrated in *The Hop Atlas* (Barth *et al.*, 1994), solely to meet the requirements of the brewing industry (Table 7.1); the amounts used by herbalists and for hop pillows are negligible. Hops of commerce are the dried cones of the female plant but today much of the crop is processed into pellets and extracts. In Europe the yield of hops is usually expressed in zenters (1 zenter = 50 kg = 110.23 lb.) but in the USA, the yield is usually expressed in pounds.

Although hops were probably used first for their preservative value, they introduced bitterness and a pleasant flavour, which was liked, and which is the reason for their continued use. These flavours were found to originate mainly in the resins and essential oils found in the lupulin glands of the hop. The chemistry of the hop resins and essential oils is discussed in detail in Chapter 8 but it is useful to note here that from the brewing standpoint the most important hop resins are the alpha-acids (α -acids) sometimes referred to as ‘alpha’. In conventional brewing hops are boiled with sweet wort for $1\frac{1}{2}$ –2 hours during which time the α -acids go into solution and are isomerized into the iso- α -acids, the main bitter principles of beer. In open coppers the bulk of the essential oil constituents are vaporized during this period of boiling so brewers may add a portion of choice ‘aroma’ hops late in the boil to replace this loss. Alternatively, dry hops may be added to beer, either in cask or conditioning tanks, to introduce hop aroma – a process known as dry hopping.

Table 7.1 World production of hops and alpha acids – 2002

Country	Hop acreage (hectares)	Production (metric tonnes)	Alpha production (metric tonnes)
Australia	862	2384	316.9
Austria	225	296	20.6
Belgium	250	438	43.0
Bulgaria	239	303	28.9
China	5642	14167	1423.1
Czech Republic	5968	6200	10.8
Germany	18354	31500	2951.0
France	814	1550	43.8
New Zealand	406	884	95.3
Poland	2197	1800	76.0
Portugal	37	57	5.5
Russia	862	440	56.6
Slovakia	350	350	12.2
Slovenia	1816	2200	151.0
South Africa	500	965	117.5
Spain	730	133	13.3
UK – England	1896	2653	242.0
Ukraine	1778	1000	48.9
USA	11864	25815	3140.0
Yugoslavia	493	616	35.1
2002 Totals	55058	93455	8810.0

Source: November 2002 IHGC Report

7.2 Botany

Three species of *Humulus* are known, *H. lupulus*, *H. japonicus* and *H. yunnanensis* (Neve, 1991). *H. lupulus* is indigenous to and is cultivated in much of the Northern hemisphere between 35° and 55° N but it is also cultivated in the Southern hemisphere in Australia, New Zealand and South Africa. *H. japonicus* is widespread in China and Japan but it lacks lupulin glands and therefore brewing value; it is sometimes grown as an ornamental garden plant. Little is known about *H. yunnanensis* from southern China. *Humulus* and *Cannabis* are the only two genera in the family Cannabinaceae; some authorities classify them in the Moraceae. *Cannabis* is represented only by *C. sativa* L. (Indian hemp, hashish, marijuana). There are some chemical similarities between hops and hashish but the resins of the two species are distinct; those of hops provide the bitter principles of beer while those of *Cannabis* include the psychotomimetic drug, tetrahydrocannabinol. *Cannabis* and *Humulus* spp. have been grafted on to each other but the characteristic resins do not cross the grafts.

The hop is a perennial climbing plant; the aerial part dies off in the autumn but the rootstock stays in the soil, sometimes for many years. The plant needs a support up which to grow. In the wild, hops are found in hedgerows but for cultivation they are trained up strings attached to permanent wirework. In the spring the stem tissue in the upper part of the rootstock produces numerous buds from which many shoots develop. The farmer selects the strongest shoots and trains them clockwise up the strings. As the bines climb, young flowering shoots develop in the leaf axils – the so-called ‘pin’ stage - which then form the young female inflorescence with papillated stigmas – the ‘burr’ (Fig. 7.1). From this the strobiles or hop cones develop. The cones consist of a central strig with bracts and

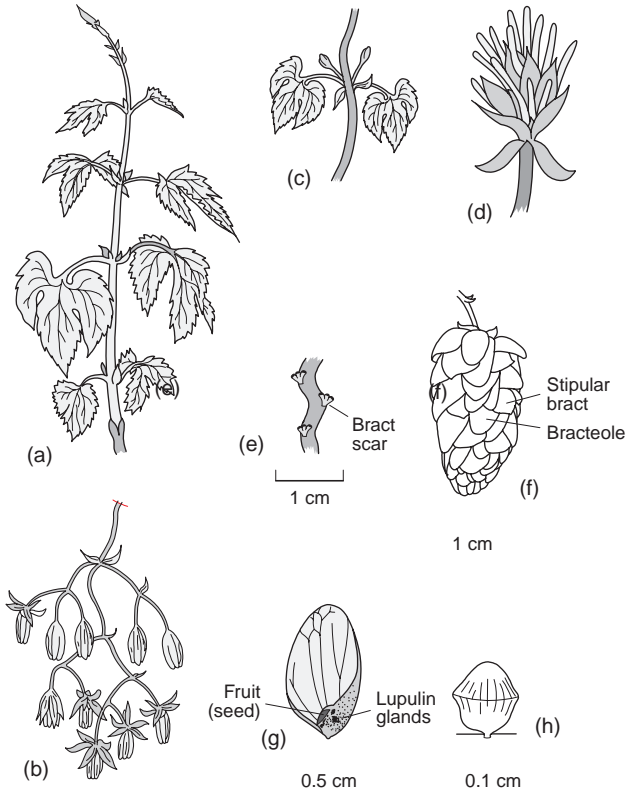

Fig. 7.1 Hop (*Humulus lupulus* L.) (a) young shoot; (b) male flowers; (c) 'pin', young flowering shoot developing in the leaf axils; (d) 'burr', young female inflorescence with papillated stigmas; (e) part of axis ('strig') of cone; (f) single mature hop cone; (g) bracteole with seed and lupulin gland; and (h) lupulin gland (After Burgess (1964) and Neve (1991) by kind permission of Kluwer Academic Publishers).

bracteoles attached. Most of the lupulin glands are formed at the base of the bracteoles but they are readily detached and adhere to the bracts, strig and seed (Fig. 7.1). A few lupulin glands are found on the undersides of hop leaves but not enough to make these useful for brewing. The lupulin glands can contain as much as 57% of α -acids and the sum of the ($\alpha + \beta$)-acids is equal to $75 \pm 6\%$ of the weight of the gland. The ratio α/β can range from 0 to about 4. The amount of resin/gland is fairly constant; the 'high-alpha' varieties (see later) contain many more glands than the 'low-alpha' varieties. It is predicted that the maximum lupulin content/cone that could be obtained by breeding is about 32% w/w which corresponds to a ($\alpha + \beta$) content of about 23% of the cone (Likens *et al.*, 1978) New varieties with over 16% α -acid have been bred.

The hop is dioecious, male and female flowers are produced on different plants. Male flowers have five sepals and five anthers but since the flowers drop off after flowering any brewing value is lost. However, the male flowers produce pollen which can be carried long distances by the wind so any female plant in the vicinity will be fertilized and produce seeds at the base of the bracteoles. Despite many demonstrations that excellent lager beers can be produced with seeded hops, lager brewers do not like seeds so most varieties are grown 'seedless'. In Europe this means that dried hops contain less than 2% w/w of seed; in the USA the limit is 3%. It was shown in England, as long ago as

1908, that the yield/acre was higher if the hops were fertilized so English growers were encouraged to plant male hops in their gardens and by now many are wild in the hedgerows. Fertilized hops may contain as much as 25% w/w of seed. In contrast, in Germany, except in breeding stations, male hops must be removed by law. In the USA most varieties are grown seedless but in some areas males are planted. For example, a commercial yield of the variety Fuggle could not be obtained in the absence of male hops. The bulk of the English hop crop contains seeds in excess of the European limit but in isolated areas male hops have been removed and the crop grown seedless. The hop plant is usually diploid with 20 chromosomes but triploid plants have been bred which are very infertile and have a low level of seeds even when pollinated.

The growth of hops is strongly influenced by the amount of daylight. They require at least 13 hours of daylight for vegetative growth to occur; with shorter periods the plant becomes dormant. The plant must produce 20–25 nodes before being ready to flower when the days shorten. However, flowering will be inhibited if the days are too long. In South Africa, where the daylength is marginally too short, artificial light has been used to delay flowering and so improve the yield. Hops have also been grown in Kenya but here artificial light is necessary to allow vegetative growth as well as to delay flowering. A period of illumination in the middle of the night is probably more efficient than delaying nightfall.

7.3 Cultivation

Setting up a hop garden or yard requires considerable capital and the necessary wirework is not readily adaptable to any other crop so, once a garden is established, farmers will continue to grow hops even if it is barely profitable. The wirework must support the weight of the crop, probably in adverse weather conditions, so the corner posts must be at least 15 cm (6 in.) in diameter but the intermediate posts, every third or fourth hill, need not be so robust. Wooden posts are usually used but sometimes concrete or steel posts are more readily available. Before the advent of mechanical picking the wirework in English gardens was 3.75–4.25 m (12.5–14 ft.) high. At harvest the bine was cut down from the overhead wirework and the hops were picked by hand in the garden into coarse woven sacks called pokes. Hop picking in Kent was the annual holiday of many from the East End of London; in the West Midlands the pickers came from Birmingham. As the bine withered the nutrients therein returned to the rootstock. This was not possible with mechanical picking when the bine was cut down from the wirework and above the rootstock and transported in a trailer to a static picking machine. Then, higher wirework was advantageous as in America (4.0–5.5 m, 13–18 ft.) and continental Europe (6.0–7.0 m, 20–23 ft.).

In height-of-wirework trials at Wye College, Kent, the maximum yield of most varieties was with 5 m (16 ft.) wirework but some vigorous varieties showed increased yields at 5.5 m (18 ft.). As well as the height of the wirework, the layout and stringing patterns in hop gardens can show considerable regional variations. Nowadays the rows of plants are usually 2.8–3.2 m apart to allow tractors to pass freely. In Germany and continental Europe there is often a spacing of 1.5 m between plants or hills with two wires/hill. In the USA the spacing between rows and plants is about 2.25 m with two strings to each plant. In England practice differs between Kent and the West Midlands. In Kent the spacing between rows and plants within rows is 2 m but with the umbrella system of stringing there are four strings/hill. In Worcester the distance between rows

may be as much as 3 m but within the rows the plants are only 1 m apart with two strings/hill. One-year old plants will be used to lay out a new garden.

Apart from breeding new varieties, hops are propagated vegetatively from 'setts'. Three techniques are used to produce setts: (i) hardwood 'strap cuts' are taken from the base of the rootstock in winter and allowed to root, (ii) layering, and (iii) mist propagation. For layering, a bine is allowed to grow until it is taller than the distance to the next hill. It is then taken down, laid along the ground, covered with soil, and the top of the bine trained up the next hill. In the autumn the hardwood bine is uncovered and cut up, each piece with a node, and planted out in nursery beds. With mist propagation, young growing shoots are taken and cut up each piece with two nodes and two leaves, rooted in sterilized peat at 21 °C under an intermittent mist-like spray controlled by an 'electronic leaf'. Under these conditions the plant remains turgid and rooting takes 10–14 days. After hardening off the plants are transferred to a nursery garden. It is obviously most important that only healthy plant material should be used to lay out a new garden. It should be free both of viruses and viroids. In order to reduce the risk of infection, commercial hop propagators are usually sited well away from the main hop growing areas. For example, in England, they are in East Anglia, well away from Kent and the West Midlands.

When a garden is laid out a strong hook or peg is put into the ground near each hill to facilitate stringing. In England this is carried out by a man on the ground with a long pole and a continuous length of coir string. In bygone days stringing was carried out by men on stilts. In continental Europe cut lengths of soft wire are used. In the USA and Australia cut lengths of string are used and attached to the upper wire by men in a tractor-drawn tower. As might be expected the largest yield/plant was obtained with the widest spacing but the highest yield/hectare was obtained with closer spacing. The angle of slope of the string also influences the yield. In England the highest yields were obtained with a slope of 65° but in Germany with a slope of 72–78°.

Traditionally, hop growing involved intensive cultivation but today, with the high cost of labour, 'non-cultivation' is becoming increasingly popular. This involves controlling the weeds with herbicides (Paraquat in the autumn and Simazine in the spring). It was found that non-cultivation did less damage to the soil structure. As mentioned above, when the bines are about 0.5 m (18 in.) long they are trained clockwise up a string; usually two or three bines/string. Where practical, complete or partial self-training may be employed. Excess shoots may be cut off or removed with a chemical defoliant. The latter technique is also used to remove leaves and laterals from the lowest 1–3 m (3–6 ft.) of the bine. This helps to discourage mildew and red spider mites. The defoliants used include tar oil with sodium monochloroacetate. Paraquat and Diquat can be used when the bines reach the top wire but may damage younger plants.

The hop is a deep-rooted plant which requires a good depth of soil, the pH of which should be kept above pH 6.5 by liming. The luxuriant growth of the plant makes heavy demands on soil nutrients which must be replaced. However, the present view is that earlier fertilizer regimens, for example, up to 225 kg N/ha, were excessive. It is recommended that, wherever possible, fertilizer treatments should be based on soil analyses and for nitrogen should not exceed 135 kg/ha. In Germany it is recommended that fertilizer treatments should be calculated from the amount of nutrient removed with the crop. The soil nitrate level should also be monitored. Hops contain up to 1.2% w/w of nitrate, which could significantly influence the level of nitrates in beer. Low levels of nitrates are desirable in beer because they can be reduced to nitrites, which can react with primary and secondary amines to produce carcinogenic *N*-nitrosoamines. It is also

recommended that phosphate and potash fertilizer treatments should be based on soil analyses and not exceed 300 kg P₂O₅/ha and 450 kg K₂O/ha. With high residual levels no further treatment may be necessary. Soil analysis may also indicate the need for additional magnesium, 30–100 kg/ha, to prevent the plants becoming chlorotic. Trace element deficiencies due to a lack of zinc and/or boron have been observed in hops.

In England and western Europe the water requirements of the hop crop are usually supplied by natural rainfall but elsewhere irrigation is often necessary. In the USA the crop requires 400–500 mm (18–20 in.) of rain in the Willamette valley, Oregon and 760 mm (30 in.) in the Yakima valley, Washington State, which is supplied by furrow irrigation. Elsewhere, in Australia and in the Backa area of Serbia, overhead sprinkler systems are used. It is claimed that irrigation produces better hops, of more even quality, than natural rainfall.

As the hop ripens in the Northern hemisphere, the first traces of resin can be detected in early August, the β -acids a few days before the α -acids, and resin synthesis is almost complete by the end of the month. De Keukeleire *et al.* (2003) have measured the formation and accumulation of α -acids, β -acids, desmethylxanthohumol and xanthohumol during flowering. Essential oil synthesis starts later and in some varieties resin synthesis may be complete before essential oil synthesis starts. Oxygenated compounds and sesquiterpenes are formed first but as the hop ripens the synthesis of myrcene becomes quantitatively the most important process. Different varieties mature at different rates so a grower may choose a mixture of early and late maturing varieties to spread picking over three to four weeks in September.

The characteristics by which a grower decides that the crop is ready for picking are (Burgess, 1964):

1. The bracts and bracteoles close towards the axis of the cone giving it a compact form.
2. The full growth of the terminal bracteole, when seeded, causes it to protrude from the top of the cone.
3. The bracts and bracteoles become firm and slightly resilient. They rustle when squeezed in the hand and are rather easily detached from the axis.
4. The colour of the bracteoles and, to a lesser extent, the bracts changes to a yellowish-green.
5. The contents of the seed become firm. The fruit coat (pericarp) becomes brittle and of a purplish colour.
6. The lupulin glands are completely filled with resins.
7. The aroma of the hop is fully developed.

Hops should be picked as soon as possible after they become ripe; overripe cones tend to open and become more fragile and thus may be easily shattered by the wind, birds, or during picking. In all cases hops should be picked within ten days of ripening.

As mentioned above, the bines are cut down from the top of the wirework and 1.2–1.5 m (4–5 ft.) from the ground and laid on a trailer for transport to a static picking machine (Fig. 7.2). Here the bine is attached to a trackway and, depending on the design, enters the machine either horizontally or vertically. The hops and leaves are stripped from the bine by numerous moving wire hooks and then passed over various screens to separate the hop cones from unwanted debris. According to EEC regulations certified hops must not contain more than 6% of leaf and more than 3% of waste. The waste from the picking machine may be composted but should be burnt if there is any risk of disease. Mobile picking machines that can pick the hops in the garden have been designed but for

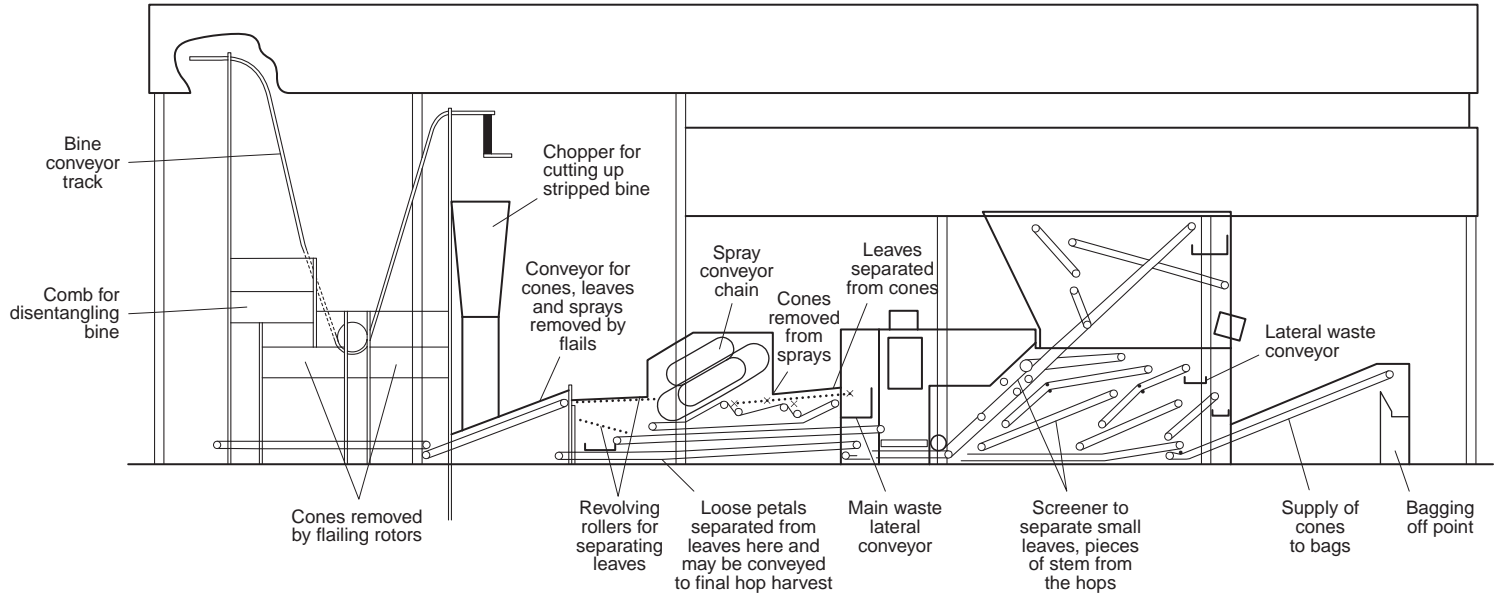

Fig. 7.2 Hop-picking machine (Courtesy of Bruff Mfg. Co. Ltd.)

high wirework they are large, heavy and clumsy and have not been widely used. However, mobile picking machines have been successfully used with dwarf hops (see pages 249–50). Green hops contain about 80% w/w moisture and must be dried as soon as possible after picking. While waiting to be put on the kiln the hops must not be allowed to ‘sweat’ as this will seriously reduce the quality of the crop. Although the vast majority of the crop is dried, some brewers in hop growing areas make seasonal brews using green or partially dried hops (feathered at 40% moisture) which have exaggerated hop flavours.

7.4 Drying

Most hops are dried on the farm to a final moisture level of about 10% w/w or less. However, in Germany the farmer dries his hops to about 14% moisture and then sends them, loosely packed, to a merchant. The merchants sorts and blends the hops and then completes the drying to the specified level. In a traditional English circular oast house the hops were spread on a horsehair cloth on a slatted floor 4.5 m (12–16 ft.) above a charcoal or anthracite fire. The drying floor is equipped with two sets of doors, the green hops are loaded on one side and the dried hops removed onto a conditioning floor on the other. Only natural draught, produced by tapering the roof to a cowl, was available and this was less than 0.1 m/s (19 ft/min) and only capable of drying a shallow (20–27 cm, 8–12 in.) bed of hops.

Modern kilns are more likely to be rectangular, the air heated directly or indirectly with an oil burner and blown, or sucked, through the bed of hops with a powerful fan (Fig. 7.3). If an oil burner heats the air directly it is necessary to ensure complete combustion so the hops are not contaminated with unburnt oil. To avoid this a heat exchanger or stove may be used to heat the air. The air speed and temperature have to be carefully controlled throughout the drying as α -acids are destroyed with increasing air temperature. When the hops are first put on the kiln with c. 80% moisture, evaporation cools them below the air temperature but as the hops dry they approach the air temperature. If the air speed is too low, the air may become saturated with moisture in the lower layers of the bed and then deposit moisture on the hops in the upper layer. This ‘reek’ results in serious discoloration of the hops which will result in a poor hand evaluation. On the other hand, air speeds of

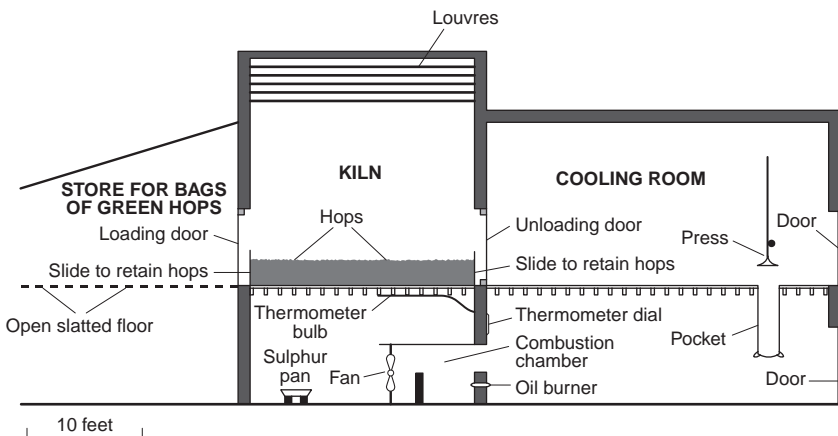

Fig. 7.3 Modern oast house (Burgess, 1964)

above 0.3 m/s (60 ft./min) are likely to blow hops off the bed (sometimes a wire mesh is used to retain them). In practice hops are usually dried with air between 60–80 °C (140–176 °F) and at a speed of 0.2–0.3 m/s (40–60 ft./min).

For the most efficient use of fuel, the air leaving the bed of hops will be almost saturated with moisture. This is easily achieved when the hops are first put on the kiln but the removal of the last few percent of moisture is much less efficient. This does not matter where fuel oil is cheap, as in the USA where deep layers (up to 1 m, 40 in.) of hops are dried on large floors (e.g. 13.4 m × 13.4 m, 32 ft. × 32 ft.) at 60–65 °C (140–150 °F). In Europe, where fuel is more expensive, multi-layered kilns have been built with movable floors like venetian blinds. Green hops are put onto the top floor and when dried hops are removed from the bottom floor, the partially dried hops are dropped to a lower level and the top floor reloaded. Diagrams of such kilns are given by Neve (1991). However, such kilns are expensive to construct and a cheaper alternative with a single floor is to recirculate warm air towards the end of drying. In another method green hops are collected in large bins with wire mesh bottoms and the bins moved over hot air ducts at different temperatures. Continuous hop dryers have been built in Europe and again, diagrams are given by Neve (1991).

It used to be normal English practice to burn sulphur in the kiln during the first 30–45 min. of drying. This caused the hops to assume a uniform bright yellow colour which was highly rated on hand evaluation. However, sulphuring has been shown to destroy α -acids so the practice has been generally discontinued in England. In Germany merchants often burn sulphur in the final drying of the hops and in the USA some hops, but not all, are sulphured. The experience of the oast man in determining when the drying is complete is important. The remaining moisture is unevenly distributed making sampling for analysis difficult. Within the bed of hops there is more moisture in the upper layers than in the lower and in the cone most moisture is found in the strig. Accordingly the hops are removed from the kiln on to a conditioning floor where they are covered with cloths and the moisture allowed to equilibrate for several hours.

In England hops are traditionally packed in jute/polypropylene sacks called pockets. They are usually about 2.1 m (7 ft.) long and 0.6 m (2 ft.) in diameter and hold about 76 kg (170 lb.) of hops. The empty pocket is suspended through a hole in the cooling room floor beneath a press with a circular foot, usually operated by an electric motor. The base of the suspended pocket is supported further by a strong canvas webbing belt. The cooled hops are pushed into the pocket with a canvas shovel called a scuppet. When the pocket is full of loosely packed hops the press is operated and, after compression, more hops are added. The process is repeated until the pocket is tightly packed with a density of 137–145 kg/m³ (8.5–9 lb./ft.³). The pocket is then supported on the webbing belt while it is sewn up. In the USA, and increasingly elsewhere, hops are packed in rectangular bales measuring 137 × 51 × 76 cm (4 ft. 6 in. × 1 ft. 8 in. × 2 ft. 6 in.). The baling press is essentially a steel box with detachable sides in which a ram operates. The box is lined with hessian and after the final filling a hessian cloth is placed on top. While the hops are compressed by the ram, the sides are removed and the hessian cloths sewed together. Bales are more expensive to produce than pockets but the hops are more densely packed (180 kg/m³, 13 lb./ft.³) so they can be transported more efficiently. However, pockets can be rolled whereas bales have to be lifted. Before the advent of pellets bales were sometimes compressed to half their normal size for export. Most of the lupulin glands were ruptured by this treatment.

Hops deteriorate on storage, in some cases significantly, before the next season's crop makes up 100% of the hop grist (70–100 weeks). The deterioration can be slowed either by cold storage at 0.20 °C (33 °F) and/or by storage in an inert atmosphere. For pockets or

bales cold storage is the most practical but pellets are usually packed in an inert atmosphere. The pattern of deterioration shows a lag period, which appears to be a varietal characteristic, probably due to the amount of antioxidants present (Lemusieau *et al.*, 2001), followed by a period when the loss of both α - and β -acids can be fitted to either zero-order or first-order rate equations (Green, 1978). The chemical changes that take place during storage and the methods of chemical analysis are discussed in Chapter 8. Samples for chemical analysis are taken with a 'cork borer' sampler 70–80 mm in diameter and 200–250 mm long with a serrated edge at the cutting end. For hand evaluation a square sample approximately 10 cm \times 10 cm \times 10 cm (4 in. \times 4 in. \times 4 in.) is cut from the middle of the pocket. From this sample the expert will verify that it is true to type and variety, assess the wholeness of the cones on the face and cut side of the sample and assess the aroma by rubbing the cones between the palms and inhaling. The stickiness of the sample gives an indication of the resin content. The expert will also determine whether any cone damage or discoloration is due to superficial mechanical damage or wind bruising as opposed to pests and diseases. In particular he will look for aphid and/or red spider mite infestation, powdery mildew, downy mildew or other diseases. Further, he will assess that the leaf and strig content is below the EEC limit of 6%, that the moisture content is below the EEC limit of 12% and, from the brightness or dullness of the sample, determine if the hops had been picked under wet conditions or if the air flow in the oast had not been properly controlled. English hops are graded on the basis of hand evaluation. For alpha/aroma varieties (see pages 249–52) and high alpha varieties there are two grades: grade I hops attract the base contract price but there is a deduction for grade II hops. For aroma hops there is also a 'choicest' grade that receives a premium above the base contract price.

7.5 Hop products

Whole hops are a bulky, sticky product not suited to automated delivery into the copper. They only contain about 20% of useful brewing materials which are concentrated in the lupulin glands. Any concentration of these active principles will reduce transport and cold storage costs and give a product easier to store in an inert atmosphere. The main hop products are listed in Table 7.2. The non-isomerized products, added to the copper, are utilized (see page 271) no better than whole hops. Hop powders, although much denser than whole hops, are still sticky and unsuitable for automated dosing. They are not commercially available but are converted into pellets.

7.5.1 Hop pellets

For the preparation of hop pellets it may be necessary to dry the hops further so they contain 8–10% moisture. They are then cooled to -30°C and crushed in a hammer mill. For Type 90 pellets (normal hop pellets), the resulting powder (1–5 mm) is homogenized in an orbital screw mixer and then pelleted in a ring or horizontal die. Friction within the die will raise the temperature which should not be allowed to exceed 55°C . In the die the lupulin glands will be crushed so it is important that the pellets should be cooled and packed as soon as possible. The pellets are usually packed in metallized polyethylene laminate foils (0.1–0.15 mm thick) either under a vacuum (hard packs) or under an inert gas (nitrogen or carbon dioxide) at atmospheric pressure (soft packs). The packs are usually protected in cardboard boxes and are ideally stored at $1-5^{\circ}\text{C}$. Pack sizes range

Table 7.2 Hop products

Non-isomerized
Double-compressed whole hops
Hop pellets Type 90
Hop pellets Type 45
Stabilized hop pellets
Solvent extracts: hexane
ethanol
liquid carbon dioxide
supercritical carbon dioxide
Isomerized hop products
Isomerised hop pellets
Isomerized kettle extract
Isomerized hop extracts for post-fermentation bittering
Reduced isomerized hop extracts: Dihydro- ρ (rho)-iso- α -acids
Tetrahydroiso- α -acids
Hexahydroiso- α -acids
Hop oil products
Hop pellets Type 100
Oil-rich hop extract
Pure hop oil: steam distillation
molecular distillation
Hop oil emulsions
Fractionated hop oil
Dry hop essences
Late hop essences – spicy, floral, estery and citrusy
Miscellaneous
Base hop fraction
Purified beta fraction

(European Brewery Convention Manual of Good Practice – Hops and Hop Products, 1997)

from 2–150 kg or may contain a specific weight of α -acid so that the whole contents of a pack may be added to the copper without further weighing. The pellets are approximately 6 mm \times 10–15 mm with a bulk density of 480–550 kg/m³ (cf. whole hops at c. 140 kg/m³). Such pellets are called Type 90 because roughly 90 g of pellets are obtained from 100 g of hops but 98% of the α -acids (dry weight) are recovered. At the start of the 21st century over 50% of the hop crop was processed into pellets. At least one large hop farm in the USA processes the hop crop directly into pellets.

For lupulin-enriched hop pellets (Type 45) the hop powder from the hammer mill is sieved at –30°C. The material that passes through a 0.3 mm sieve contains the lupulin glands and represents about half of the weight of hops used; the larger particles go to waste. The bulk density of the Type 45 pellets is similar to that of the Type 90 pellets but the Type 45 pellets contain twice as much of the brewing principles. By further sieving it is possible to obtain a fraction composed almost entirely of lupulin glands but this is not necessary for brewing purposes.

Stabilized hop pellets are prepared by mixing up to 2% by weight of magnesium (or calcium) oxide with the hop powder before pelletization. In the die the α -acids are converted into their salts which are more stable than the free acids. During storage the α -acid salts may isomerise into iso- α -acid salts which are better utilized than α -acid salts. If stabilized hop pellets (in soft packs) are kept at 45–55°C for 10–14 days, the isomerization is complete and isomerized hop pellets are formed.

7.5.2 Hop extracts

Many different solvents have been used to extract the brewing principles from hops but brewers have become increasingly worried about the possibility of solvent residues in their beer so only hexane (b.p. 69°C), ethanol (b.p. 78°C), and carbon dioxide are still used and of these carbon dioxide is the most important. Although hexane is widely used in the food industry, the only hop extract plant using hexane is scheduled to close. Hexane is a non-polar solvent which will only extract soft resins and hop oil constituents from hops. In contrast, ethanol is miscible with water so an ethanol extract will also contain hard resins and polyphenols. After removal of the ethanol a mixture of resins and a hot water extract is obtained but now only the resin extract is normally used as the hot water extract is rich in nitrates.

At room temperature carbon dioxide is a gas so it can only be used as a solvent under pressure. The phase diagram (Fig. 7.4) shows that both liquid carbon dioxide (below 31°C and 73 bar abs) and supercritical CO₂ (above 31°C and 73 bar abs) can be used for extraction. Liquid carbon dioxide has been used in England and Australia but elsewhere supercritical carbon dioxide has been the choice. Despite claims made to the contrary, the composition of the two extracts is very similar. The liquid CO₂ extract is pale yellow and may contain fewer hard resins and polar bitter substances than the supercritical CO₂ extracts which are yellow to green in colour. Both are free of polyphenols and nitrates and contain few pesticide residues. Extraction with both liquid and supercritical CO₂ is a batch process. Figure 7.5 is a diagram of a liquid CO₂ extraction plant. The extractor is charged with remilled hop pellets and, typically, carbon dioxide at 60–65 bar and 5–15°C is passed through the powdered pellets. The carbon dioxide is then evaporated from the extract at 40–50°C, condensed and returned to the extraction cycle. For supercritical CO₂ extraction the cooler in Fig 7.5 is replaced by a heat exchanger. Liquid CO₂ at 60–70 bar is raised to the extraction pressure (200–250 bar) by a pump and the supercritical liquid raised to 40–60°C by a heat exchanger. After extraction the pressure on the extract is reduced to 60–80 bar before evaporation. The CO₂ is recovered, condensed and recycled as with liquid CO₂ extraction. Such CO₂ extracts can be used in the copper or as the raw material for isomerized extracts or molecular distilled oils.

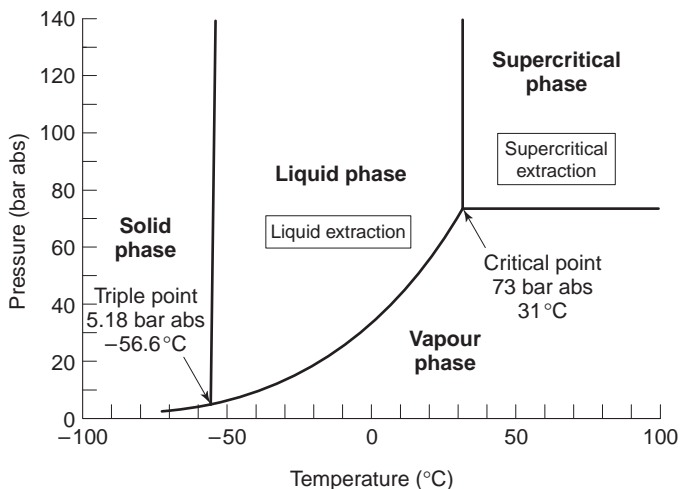

Fig. 7.4 Pressure temperature equilibria for carbon dioxide (Benitez *et al.*, 1997).

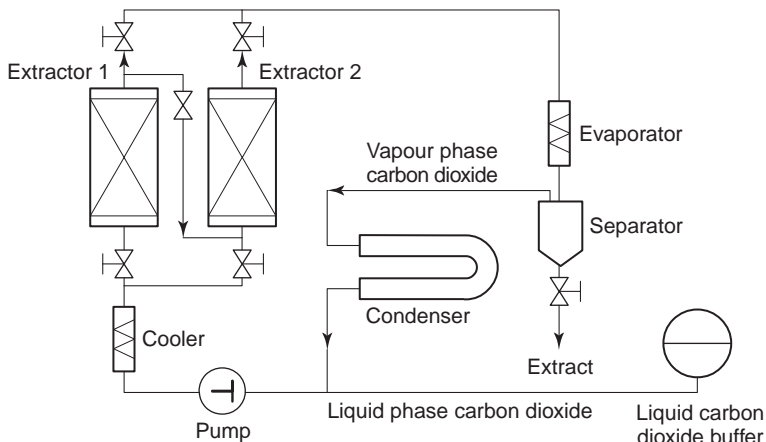

Fig. 7.5 Liquid carbon dioxide extraction with two extractors (Benitez *et al.*, 1997).

Hop extracts are usually packed in cans with food-grade linings. The cans can contain 0.5–5.0 litres or a specified weight of α -acids. The use of glucose syrup or a hot water extract of hops to dilute resin extracts is now thought undesirable; such diluted extracts have a much shorter shelf-life. For use, holes are punched in the cans which are then suspended (in a basket) in boiling wort. On a larger scale the extract is warmed to increase its mobility and then pumped into the copper (carbon dioxide extracts are less viscous than those prepared with hexane or ethanol). Isomerized and reduced hop extracts, designed for post-fermentation addition, are discussed in Chapter 8.

7.5.3 Hop oils

By definition, essential oils are volatile in steam so they are prepared by steam distillation. Usually minced hops are boiled with water and the condensate is collected in a trap which retains the oil and allows the aqueous phase to return to the boiler – a process known as cohobation (the same technique is used in the analytical determination of hop oil). Such hop oil preparations have been available for many years, and some brewers used them in place of dry hopping, but they do not retain the true aroma of the hop and beers so treated could usually be distinguished from those which had been dry hopped. It is likely that some constituents are damaged at 100 °C and any constituents slightly soluble in water would be washed out in the trap.

By steam distillation under reduced pressure (0.008 mm Hg) at 25 °C, Pickett *et al.* (1977) obtained hop oil emulsions that were comparatively stable and imparted a sound hop character to beer. However, hop oil constituents are soluble in liquid and supercritical CO₂ with no risk of thermal degradation. The hop oil constituents are more soluble in liquid CO₂ than the resins so extraction of a column of milled hops with 10–15% of the liquid CO₂ needed for complete extraction will recover most of the hop oil with little of the resins. Similar preparations can be obtained with supercritical CO₂ but in practice it is better to aim for complete extraction. The pressure on the extract is then reduced to 100–120 bar when the hop acids are precipitated; the hop oil constituents stay in solution and can be recovered by evaporation. Hop oils can also be recovered from CO₂ extracts by molecular distillation at low pressure (0.001 mm Hg). Such oils prepared from a single cultivar of hops retain the characteristic aroma of that cultivar and can be used, with a

food grade emulsifier, to produce hop oil emulsions (normally with an oil content of 0.25% v/v). The production of dry hop essences is discussed in Chapter 8.

7.6 Pests and diseases

Today many consumers are prepared to pay a premium for foodstuffs produced ‘organically’, that is without the use of agricultural chemicals. To meet this market some brewers are producing ‘organic’ beers from ‘organic’ barley and hops. However, hops are susceptible to attack by many pests and diseases so most hop growers need to use agrochemicals to produce a commercial crop. The agrochemicals which can be used are licensed by national or international bodies who also set a maximum allowable residue (MRL, mg/kg) for the chemical in the final product. To complicate matters the infecting organisms may develop resistance to the agent used so new agents have to be developed and approved periodically. Further, different strains of a disease may be susceptible to different agents. In general, more pests and diseases are found in the long-established hop-growing areas of Europe and North America than in the Southern hemisphere.

7.6.1 Damson-hop aphid (*Phorodon humuli* Schrank)

The most serious pest in the Northern hemisphere is the damson-hop aphid (Fig. 7.6) which overwinters as shiny black eggs in the bark of *Prunus* spp. (damson, sloe or plum). In early April wingless female insects hatch out and give birth to live young which rapidly multiply. After several generations winged females (alatae) arise which migrate to the hop when the flight threshold temperature of 13 °C (55 °F) is reached in late May or early June. The migrating alatae may not colonize the first hop plant on which they land and may show a varietal preference. However, they feed and reproduce mainly on leaves on the top of the bine. They insert their long stylets into the phloem strands of the leaves to feed which weakens the leaves and causes defoliation. The most serious situation is when the alatae enter the cones. In addition the honeydew that the aphids produce supports the growth of sooty moulds, which lower the value of the hops on hand evaluation. More heavily infected cones will turn brown and limp and will probably shatter during machine picking. Those hops that survive will not find a ready market. Any aphids that survive until September–October, when the light period falls below 13.5 h/day, form winged females which

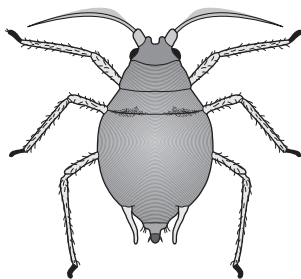
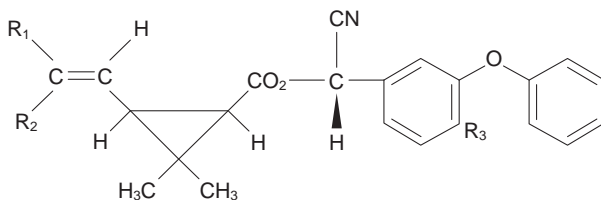

Fig. 7.6 Damson-hop aphid (*Phorodon humuli* Schr.).

(a) Insecticides/Acaricides



- (7.1) $R_1 = R_2 = \text{Cl}$, $R_3 = \text{H}$ Cypermethrin
 (7.2) $R_1 = R_2 = \text{Cl}$, $R_3 = \text{F}$ Cyfluthrin
 (7.3) $R_1 = R_2 = \text{Br}$, $R_3 = \text{H}$ Deltamethrin
 (7.4) $R_1 = \text{CF}_3$, $R_2 = \text{Cl}$, $R_3 = \text{H}$ Lambda-Cyhalothrin

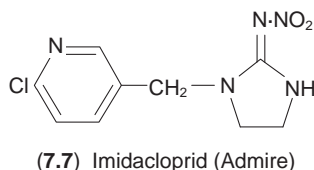
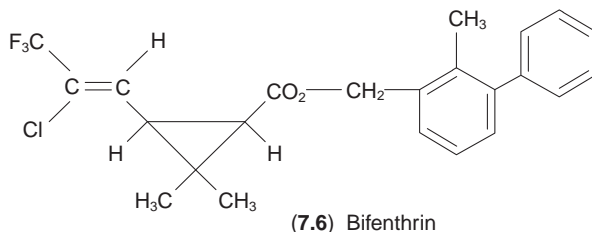
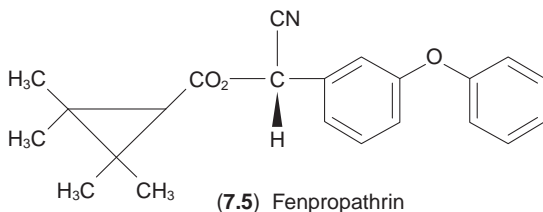
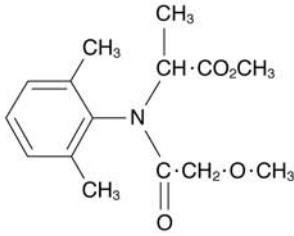

Fig. 7.7 (a) Insecticides/acaricides, (b) herbicides and (c) fungicides accepted for use on hops (British Beer and Pub Association, Technical Circular No. 376, 2003).

migrate back to *Prunus* spp. The males follow later and the fertilized females lay the eggs which overwinter.

Control includes removing *Prunus* sp. from nearby hedgerows but the alatae can fly considerable distances. It is important that the grower knows when migration onto the hop starts so that he can maximize his control measures. Usually this involves spraying with suitable insecticides such as the synthetic pyrethroids. Cyfluthrin, Cypermethrin, Deltamethrin, Fenpropathrin, Lambda-cyhalothrin, or Imidacloprid (Fig. 7.7). For many years organo-phosphorus insecticides were used but in Europe most aphids have developed resistance to these agents but they may still be effective elsewhere. As mentioned, most brewers are not happy with the risk of agrochemical residues in their

(b) Fungicides



(7.8) Metalaxyl (Ridomil)
 $\text{CuCl}_2 \cdot 2\text{CuO} \cdot 4\text{H}_2\text{O}$
 Copper oxychloride

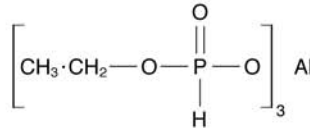

(7.9) Fosetyl Aluminium
 Sulphur

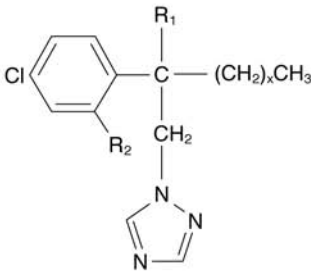

(7.10) $\text{R}_1 = \text{CN}$, $\text{R}_2 = \text{H}$, $x = 3$
 (7.11) $\text{R}_1 = \text{H}$, $\text{R}_2 = \text{Cl}$, $x = 2$

Mycobutanil
 Penconazole

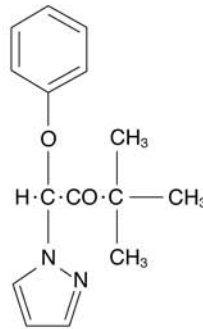

(7.12) Tridimefon (Bayleton)

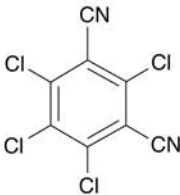

(7.13) Chlorothalonil

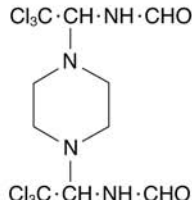

(7.14) Triforine (Saprol)

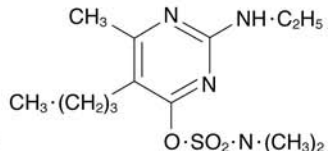

(7.15) Bupirimate (Nimrod)

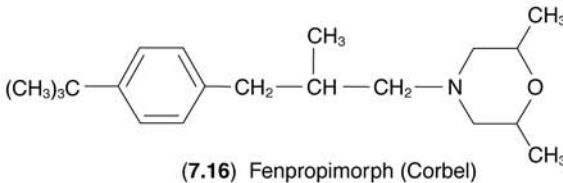

(7.16) Fenpropimorph (Corbel)

Fig. 7.7 Continued.

raw materials, so there is considerable interest in the biological control of aphids using, for example, ladybirds (*Coccinellidae*) but such control is never complete. Hops with resistance to aphids have now been bred and are being evaluated. The ASBC describe methods for estimating the number of aphids in a sample of hops.

(c) Herbicides

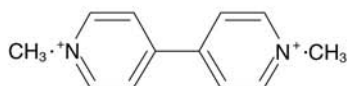
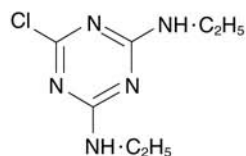
(7.17) Paraquat 2Cl^- 

(7.19) Simazine

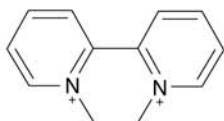
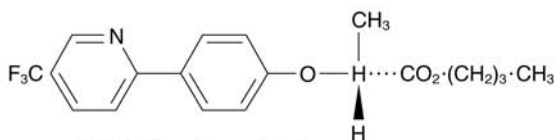
(7.18) Diquat 2Br^- 

(7.20) Fluzifop-p-butyl

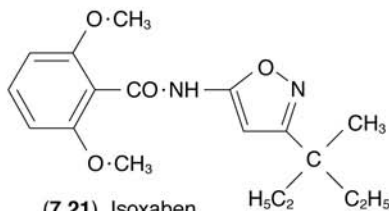

(7.21) Isoxaben

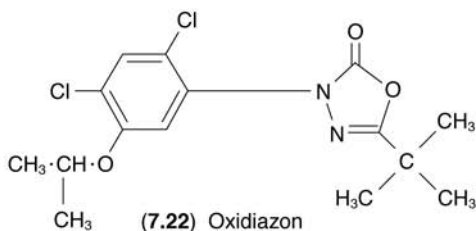

(7.22) Oxidiazon

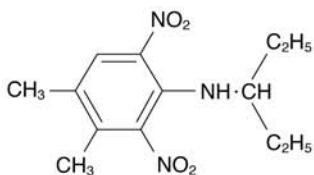

(7.23) Pendimethalin

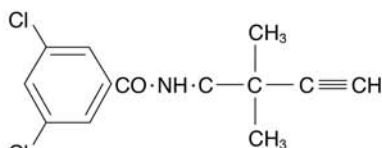

(7.24) Propyzamide

Fig. 7.7 Continued.

7.6.2 (Red) Spider Mite (*Tetranychus urticae* Koch)

The spider mite is widespread and flourishes in hot dry conditions. The bright red females overwinter in the soil, under leaves or in cracks in hop poles. In the spring they climb the bines and suck sap from epidermal and sub-epidermal cells. They lay small translucent eggs and the mites that emerge are greenish-yellow with black markings (two-spotted

mite). The first sign of mite attack is a silvery speckling of the hop leaves. Small numbers of mites do not do much damage but severe infestation may result in loss of crop. When hops were first treated with organo-phosphorous insecticides there was good control of both aphids and mites but later both species developed resistance. The acaricides in use today include Bifenthrin and Propargite.

7.6.3 Other pests

At least 40 insect species have been found living on the hop but, with the exception of the species discussed above, they do not usually cause serious damage. Other pests include the dagger nematode (*Xiphinema diversicaudatum*), which may be the vector for the Arabis Mosaic Virus (AMV), the hop-root eelworm (*Heterodera humuli*), clay-coloured weevils (*Otiorrhynchus singularis*), the rosy rustic moth (*Hydroecia micacea*), the flea beetle (*Psylliodes attenuata* Koch), earwigs (*Forficula auricularis*), wireworms (*Agricotes* spp.), and slugs (*Agriolimax reticulatus* and *Arion hortensis*) (Neve, 1991).

7.6.4 Downy Mildew (*Pseudoperonospora humuli* (Miyabe and Tak.) G. W. Wilson)

Worldwide, downy mildew is probably the most serious disease of hops. It was first observed in Japan in 1905, in the USA in 1909, and in England and Europe by 1920. It is found in most hop-growing areas of Europe and North America but, by applying strict quarantine precautions, has been kept out of Australia, New Zealand, and South Africa. The fungus survives the winter in the rootstock of the hop plant. In spring, when the hop produces numerous shoots, it migrates to infect some of the shoots so that they do not develop and produce stunted basal spikes which are the characteristic symptom of the disease (Fig. 7.8). On the undersides of the leaves of these spikes numerous black spores (conidia) develop which readily infect other young leaves (Fig. 7.9). Under wet conditions the conidia germinate on the leaves and produce motile zoospores which enter the plant through open stomata. Such infection causes black angular spots on the leaves. Infection of the growing tip of the bine will cause extension to cease and the formation of a basal spike. If the zoospores infect the flower or 'burr' no cone will develop. If they enter a developing cone serious losses will occur; some of the bracts and bracteoles will turn brown giving the cones a variegated appearance and lower the value of any crop.

Control involves the early removal of all basal spikes and lower leaves with infecting conidia. If this is done by hand all infected material should be burnt but by spraying with defoliating chemicals (anthracene oils, Diquat, Paraquat, or sodium monochloroacetate) any spikes will be killed *in situ*. Before downy mildew appeared on hops, copper fungicides, such as Bordeaux mixture, were widely used to control mildew on grapes, and such treatments were readily applied to hops. Later, copper oxychloride was found to be less phytotoxic than Bordeaux mixture. In the 1950s organic dithiocarbamates such as Zineb were favoured but the Pesticide Safety Directorate has revoked the approval of such chemicals. The most effective fungicides in use today are Metalaxyl (Ridomil) and Fosetyl-aluminium (Aliette). These can be used as foliar sprays or as a soil drench when they are capable of eliminating the fungus from the rootstock. However, this latter method of application has been discontinued in England in fear that the fungus was developing resistance to Metalaxyl. Metalaxyl is applied as a foliar spray in admixture with copper oxychloride. Other approved fungicides include Chlorothalonil, Fenpropimorph (Corbel), Myclobutanil, and Peconazole (Topas). Despite the fact that Metalaxyl

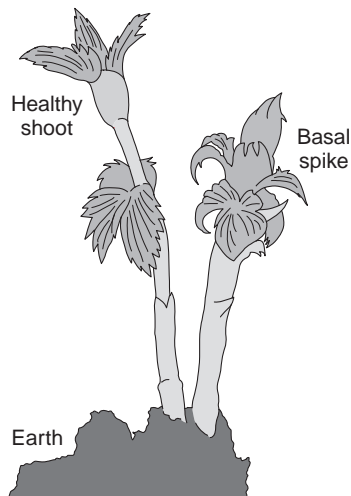

Fig. 7.8 Hop plant infected with downy mildew (*Pseudoperonospora humuli*). Left: healthy shoot. Right: basal spike.

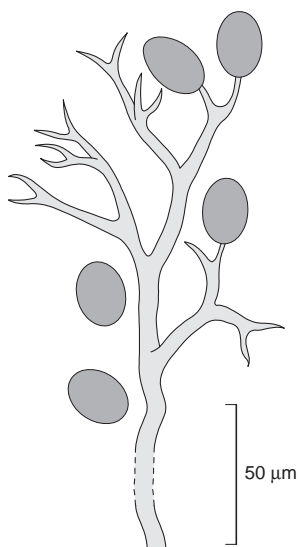

Fig. 7.9 Downy mildew (*Pseudoperonospora humuli*). Sporangiophore with sporangia (Burgess, 1964).

can eliminate the fungus from the rootstock, it is good practice to dig up and burn any rootstock that has been infected and replace it with healthy material. Varieties with resistance to downy mildew are being bred.

7.6.5 Powdery mildew (*Sphaerotheca macularis* (DC.) burr)

Mould, white mould, red mould or powdery mildew are synonyms for this fungal disease that appears as white pustules on the leaves. Towards the end of the season red overwintering spores (perithecia) are formed. The disease has little effect on the

vegetative growth of the host but serious losses occur if the cones are infected. The disease is probably more troublesome when non-cultivation is practised and plant debris infected with perithecia is left on the ground. Control involves treatment with sulphur, before burr, Triadimefon (Bayleton) and Bupirimate (Nimrod). Triforine (Saprol), which may reduce the yield, is usually reserved for serious infections.

7.6.6 Verticillium Wilt (*Verticillium albo-atrum* Reinke and Berth)

This disease, first detected in the Weald of Kent in 1924, is serious in England and Germany. It was thought, at first, to exist in two forms: mild ('fluctuating') and severe ('progressive') but the present view is that there is a continuum of strains giving infection ranging from very mild to very severe. There is no simple test, chemical or biological, to distinguish between the strains except by their behaviour towards a susceptible cultivar, e.g., Fuggle. Such tests, whether outside or in growth chambers, are of necessity slow. The fungus occurs in the soil either as spores (conidia) or as mycelium on infected debris (Fig. 7.10). It enters the hop roots and the dark coffee-coloured mycelium spreads through the

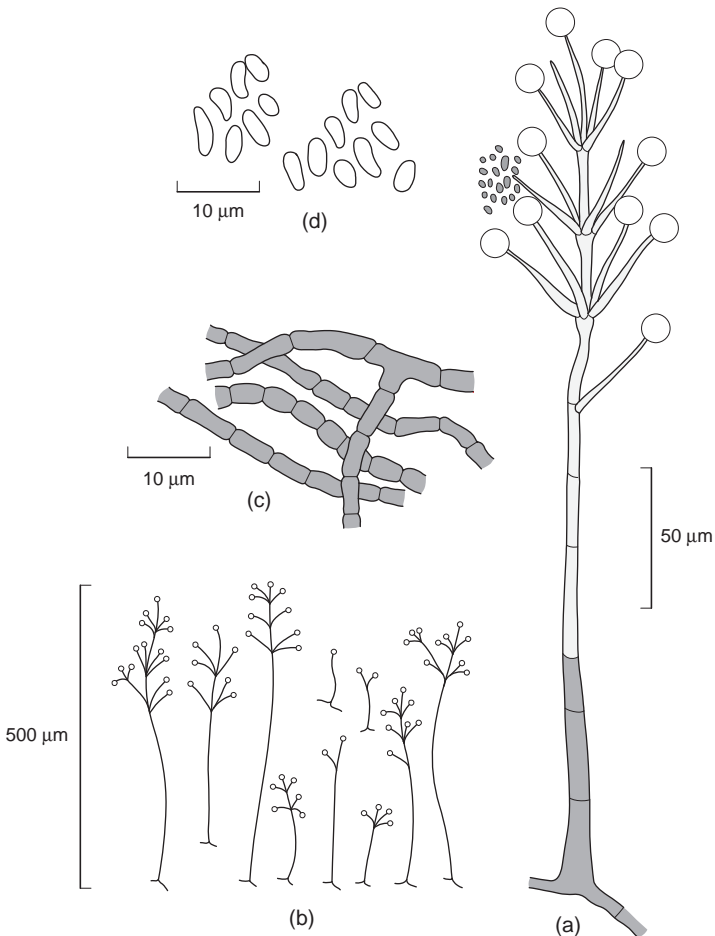

Fig. 7.10 *Verticillium* wilt (*Verticillium albo-atrum*). (a) conidiophore; conidial heads and conidia; (b) groups of conidiophore; (c) 'dark' mycelium; (d) conidia (Burgess, 1964).

vascular system of the plant to the leaves. The infected leaves develop yellow patches and black necrotic areas between the veins giving the so-called 'tiger stripe' effect before they fall off. Another symptom is that the lower 1.2–1.5 m (4–5 ft.) of an infected bine becomes swollen and may become detached from the rootstock. The wood of the infected bine shows brown areas due to the mycelia. In 'fluctuating' wilt the brown colour is restricted to the centre of the bine and the hill will probably survive with little or no increase in wilt the following year. In severe 'progressive' wilt the symptoms appear earlier in the season and are readily transferred to other plants in the garden especially in the direction of cultivation (such observations helped to popularize non-cultivation). Infected plant debris is readily carried on the wind, on boots and machinery to spread the disease.

At present no form of wilt responds to chemical agents so the only control measures are hygiene and the breeding of wilt-tolerant varieties. The *Progressive Wilt of Hops Order* (1947) attempted to restrict the disease to the Weald of Kent where wilt-tolerant varieties could be planted. Elsewhere, in 'eradication' areas, only susceptible varieties could be grown and any outbreak of the disease had to be notified, the infected plants and those nearby had to be grubbed and all infected materials burnt. The infected area was then fenced off and kept under grass for several years. Wilt-tolerant varieties must not be grown in 'eradication' areas as they may be symptomless carriers. These strict measures managed to keep the disease in check in East Kent and Hampshire and, for a time, the West Midlands. Later, wilt spread rapidly through the West Midlands so wilt-tolerant varieties may now be planted there on clean land. The wilt-tolerant varieties are discussed below. Other fungal diseases which infect hops from time to time include *Fusarium* canker (*Fusarium sambucinum* Fuckel), black root rot (*Phytophthora citricola* Sawaba), grey mould (*Botrytis cinerea* Pers.), *Alternaria alternata*, black mould (*Cladosporium* sp.) and armillaria root rot (*Armillaria mellea mellea* (Fr.) Quel.).

7.6.7 Virus diseases

In the past, virus diseases caused considerable damage to hops. Nettlehead was perhaps the most serious, the symptoms of which were well known before viruses had been recognized. In 1966 Bock identified arabis mosaic virus (AMV) and necrotic ringspot virus (NRSV) in hops. All hop plants with nettlehead contained AMV but not all plants infected with AMV developed nettlehead. It was found that a satellite of low molecular weight nucleic acid (SNA) was necessary as well as AMV to produce nettlehead. It was also found that the soil-borne dagger nematode (*Xiphinema diversicaudatum*) was a vector for AMV. Land infected with nematodes should be fumigated with dichloropropene and left fallow for two years before replanting with hops.

Hop mosaic virus (HMV) is a carlavirus transmitted by aphids feeding on one plant and then moving to another. In English Goldings it causes severe stunting, the bines fall away from the strings, and the leaves show translucent banding along the veins and curl downwards. Most other varieties are symptomless carriers of the virus and there is no evidence that HMV causes any reduction in yield with them. Nevertheless, Goldings should not be planted with, or adjacent to, other varieties. Other carlaviruses are the hop latent virus and the American hop latent virus. The Prunus necrotic ringspot virus (NRSV) rarely produces recognizable symptoms in hops but laboratory tests showed that virtually 100% of the older varieties were infected. Comparison of yields from virus-free and infected plants showed that the infected plants contained 30% less α -acid.

Enzyme-linked immunosorbent assay (ELISA) tests have greatly facilitated the detection and characterization of viruses in hops. Virus can be eliminated from hop plants

by a combination of heat treatment and meristem-tip culture. Multiplication of viruses is inhibited by maintaining the plants at high temperature and if the tip of the apical shoot is dissected out of a plant and grown under sterile conditions, the regenerated plants are usually virus-free. By such techniques virus free clones of most varieties are available to hop propagators so most new planting material, with A+ certification, is virus free.

Viroids consist of a small piece of RNA without a protein coat so they cannot be detected serologically. At least two viroids have been detected in hops. The hop stunt viroid has been found only in Japan but the hop latent viroid was found to be widespread in Germany and England; the English variety Omega was particularly susceptible. However, virus- and viroid-free planting material is now available for most cultivars.

7.7 Hop varieties

The first cultivators of hops selected the most vigorous wild plants they could find. If their neighbours' plants gave better yields they would seek planting material from them so that, in time, the same cultivar would be grown in a given area. As transport improved these areas grew larger. Indeed, German hops were named after the area where they grew, e.g., Hallertau, Tettnang, Spalt and Hersbrucker. Early growers only had small kilns or oasts to dry their crop so they were interested in having early and late varieties to lengthen the harvest period, e.g., Hallertau mittelfrüh, Hersbrucker spät.

An early rhyme suggests that:

Hops, Reformation, Bays and Beer
Came to England in One Bad Year

and that year was 1524 when Flemish immigrants brought hops to Kent. However, the finding of hop residues in a boat found in Graveney Marsh and dated c. AD 949 suggests they were known earlier (Wilson, 1975). Many different selections were grown in England. According to Burgess (1964) the Hops Marketing Board classified Amos's Early Bird (selected in 1887), Bramling (before 1865), Cobbs (1881), Eastwell Golding (before 1889), Petham Golding, Rodmersham Golding (1880), Mathon (1901), and Canterbury Goldings as Goldings and Tutsham and Whitbread's Golding Variety (WGV or 1147) as Golding varieties. Before genetic fingerprinting it was not possible to confirm how similar these varieties were. British brewers preferred Goldings but they were susceptible to mosaic viruses and the variety introduced by Richard Fuggle in 1875, which bears his name, was not. So Fuggles became popular with growers and, to a lesser extent, with brewers and in 1949 made up 78% of the English hop acreage. Goldings contain slightly more α -acid than Fuggles and have a better aroma; Fuggles was used in the copper and Goldings for dry hopping. Brewers were usually prepared to pay a premium for Goldings.

The early settlers introduced hop growing along the eastern seaboard of North America but from 1900 it moved to the North-West States of Washington, Oregon, California and Idaho. The main variety grown was Clusters (Early and Late) which contained more resin than Goldings or Fuggle but had a strong aroma described as 'blackcurrant' or 'tom-cat' which was disliked by most British brewers. Nevertheless some British brewers imported Clusters, and Salmon at Wye College set out to breed hops with more resin but English aromas. From an open pollinated wild hop from Manitoba (BB1) he obtained Brewer's Gold and Bullion which gave excellent yields and were richer in α -acids than other varieties then available. A cross between a male

seedling of Brewer's Gold and a Canterbury Golding gave Northern Brewer. These three new varieties were planted worldwide, in particular Bullion was grown in Oregon and Brewer's Gold in Germany.

Later, Northern Brewer became important in Germany because of its resistance to the German strain of *Verticillium* wilt and by 1978 these three varieties accounted for 47% of the German hop acreage. They were also grown in Belgium, Bulgaria, Spain and what was East Germany. They were less popular in Britain because of their 'American' aroma. The Germans also maintained that their traditional varieties had better aromas than the new varieties and this led to the classification of hops as either 'Aroma' hops or 'Bitter' hops. The latter usually had higher α -acid contents and were put into the copper at the beginning of the boil when any unpleasant volatiles would be evaporated. The 'Aroma' hops were reserved for late addition or dry hopping and usually commanded a higher price than 'Bitter' hops. However, there is no reason why a high α -acid hop should not have a good aroma. Salmon bred many more new varieties of hops, some of which were grown commercially for a time encouraged by the Association of Growers of New Varieties of Hops (1944–1998). They include Concord, Brewers' Standby, Early Choice, Copper Hop, Quality, College Cluster, Brewers' Favourite, Sunshine, Malling Midseason, and Norton Court Golding. These, and many only assigned code numbers, served as the parents of the next generation of new varieties.

The devastation caused by *Verticillium* Wilt in Kent prompted an urgent need for wilt-tolerant varieties. From among Salmon's seedlings Keyworth's Early, Keyworth's Midseason and Bramling Cross were found to be wilt tolerant but they were never very popular. The Whitbread Golding Variety was also wilt tolerant and was more acceptable. However, conservative brewers wanted a wilt-tolerant replacement for Fuggle and Density, Defender, and Janus were introduced in 1959 to meet this need. Again they were not very popular but Progress and Alliance, introduced in 1966, were more acceptable and Progress is still grown today. However, by this time there had been many brewery amalgamations and the accountants had more say in the boardrooms. They knew that α -acids, which could be measured, produced bitterness so they wanted high-alpha hops to produce bitterness as cheaply as possible. Aroma, which could not be easily measured, was much more subjective. Wye Northdown and Wye Challenger, introduced in 1971, had higher levels of α -acid and good aroma but were susceptible to wilt. Wye Target, however, was wilt tolerant, immune to powdery mildew, and contained up to 12% α -acid. In the early 1990s it accounted for almost 50% of the English hop acreage. Wye Viking and Wye Saxon were not successful; Yeoman was popular at first but had declined by 1998 as had Zenith and Omega. By the end of the 20th century most hop-growing countries were breeding 'super-alpha' hops with more than 15% α -acid. Wye's contribution was Phoenix and Admiral, released in 1995. 'Super-alpha' hops were wanted because it is more economic to process them than those with less α -acid and 60% of the world hop crop is processed today. However, unless the world beer market increases dramatically, there will be no increased demand for α -acid so the growth of high-alpha hops will reduce the amount and area of hops required further.

Most commercial hops are grown on wirework up to 7 m (23 ft.) high which is expensive to set up and maintain. Towards the end of the 20th century there was considerable interest in growing hops on a low trellis, not more than 3 m (10 ft.) high. The hops grow up plastic netting to produce a hedge which, besides being cheaper to set up, simplifies cultivation, spraying, and harvesting. Machines have been developed which straddle the rows and, in particular, pesticides can be applied in a much more controlled manner resulting in savings and much less environmental damage. In addition, crop

rotation is easier with the cheaper support systems. Conventional varieties can be grown on these low trellises but special dwarf varieties, bred at Wye, are more successful. Dwarf hops contain a special gene which produces short internodal distances so the plants are half the height of conventional plants. The dwarf varieties released so far include First Gold (an aroma variety), Herald (high-alpha), Pioneer (a semi-dwarf dual purpose hop) and Pilot. The yields/hectare from these low trellises are comparable with those from standard wirework.

In Germany traditional varieties were grown in five areas: Hallertau (85% of the German hop area), Spalt, Hersbruck, Tettngang and Jura. Since 1992 Jura has been incorporated into Hallertau and Elbe-Saale is a collective name given to the hop-growing areas of the former German Democratic Republic (Barth, 1999). Later, in addition to the traditional varieties, foreign varieties, Brewer's Gold, Northern Brewer and Record (from Belgium), with higher levels of α -acid were also grown. Breeding was originally started at Hüll, in 1926, to produce varieties resistant to downy mildew which retained the traditional aromas. The outbreak of wilt in the 1950s destroyed much of the major variety Hallertau mittelfrüh but Northern Brewer and Hersbrucker spät showed resistance to the German strain of *Verticillium*. Breeding continued to produce three new varieties: Hüller Bitterer (commonly known as Hüller), Hallertauer Gold, and Perle. Hüller and Perle were resistant to both downy mildew and wilt and had higher levels of α -acid than the traditional varieties. Hallertauer Gold was not resistant to wilt but both it and Perle were judged to have the same number of aroma fineness points as the traditional varieties. Taurus and Magnum are the latest German super-alpha varieties. The Saaz (Zatec) hop grown in Czechoslovakia is renowned for its fine aroma. The low yields it produces have been improved by clonal selection rather than breeding. The Saaz hop is thought to be related to the German varieties Tettngang and Spalter and the Japanese Shinshuwase. Hops were imported from England to what was Yugoslavia and the Savinga (Styrian) Golding, imported by some brewers into England, is identical with a seedless Fuggle. Yugoslavian hop breeding produced the 'Super Styrian'; the high-alpha hops Atlas, Apolon, Ahil, and Aurora. In Slovenia Blisk, Bobek and Buket have been produced and in the Backa region three more high-alpha hops were raised from Northern Brewer: Neoplanta, Vojvodina and Dunav.

In the United States also the varieties grown have changed in the last twenty years. Eighty per cent of the US hops are grown in the Yakima valley Washington State, where Clusters (Early and Late) were the main variety and the standard kettle hop. The English varieties Fuggle, Bullion, and Brewers' Gold were also grown; the last two of these varieties were sometimes classified together as 'English'. Clonal selections were made from Clusters and Talisman was released in 1968. Cascade, the first aroma hop from the US breeding programme, was released in 1972 and Willamette and Columbia in 1976. These last are triploid seedless aroma hops and Willamette still accounted for 14% of the US hop acreage in 2002. In the same year the high-alpha varieties Galena, Nugget, Columbus-Tomahawk, Zeus, Millenium and YCR-5 (Warrior) made up over half of the American hop area. Clusters accounted for only 3% but Eroica, Olympic and the English varieties had almost disappeared.

Hops are grown in Australia in Victoria and Tasmania and in New Zealand around Nelson on South Island. Being geographically isolated the hops produced in these countries are free of most of the pests and diseases found in the Northern hemisphere. Only the two-spotted mite (*Tetranychus urticae* Koch) and the red spider mite (*Panonychus ulmi*) occasionally give trouble. Thus, these countries can produce 'organic' hops, without the use of pesticides, more easily than anywhere else in the world. Such

hops from New Zealand are termed 'Bio-Gro'. The major variety grown in Australia was Pride of Ringwood, bred by Nash from Salmon's Pride of Kent, which at one time occupied 90% of the Australian hop acreage. It is now being replaced by a triploid Super Pride and two super-alpha hops Opal and Victoria. Aroma hops occupy only 4% of the Australian hop area. In contrast, they occupy almost 50% of the New Zealand acreage (Inglis, 1999). Nearly all the hops grown in New Zealand are triploids, including the dual-purpose hops Green Bullet, Sticklebract, Super Alpha, Southern Cross and Pacific Gem. The European aroma hops do not grow well in New Zealand but from Hallertau mittelfrüh two new aroma varieties more suited to New Zealand conditions have been bred, NZ Hallertau Aroma and Pacific Hallertau. In Japan the traditional variety Shinshuwase was replaced by Kirin No. 2 which, in turn, is being replaced by the super-alpha varieties Toyomidori, Kitamidori and Eastern Gold.

The characteristics of the main varieties are collected in Table 7.3. These data were collected from many sources and may not be strictly comparable. No doubt in twenty years time different varieties will be grown. Plant breeders continue to seek new varieties with increased resin content, increased disease resistance and better yields. Other goals relate to resin quality. Some brewers think that humulone gives a better bitter flavour than cohumulone so require hops in which the proportion of cohumulone in the α -acids is as low as possible. Some cultivars deteriorate on storage more rapidly than others and, since all hops cannot be processed immediately after harvest, good storage stability is desirable. Although many new varieties show resistance to fungal diseases most growers still have to use pesticides to control aphids and mites. New breeding programmes have produced aphid-resistant hops that can be grown 'organically'. The hop is a long-day plant which grows between 30 and 55° of latitude; when grown nearer the equator artificial illumination is necessary. Countries which grow hops under these conditions are trying to breed varieties adapted to the shorter day length.

The unambiguous characterization of hop cultivars is difficult although methods based on morphology and chemical analysis usually give good indications. However, methods based on DNA analysis reflect the genotype of the cultivar irrespective of the stage of plant development, the environmental or disease status. Briefly a sample of hop DNA is subjected to a random amplified polymorphic DNA (RAPD) process using arbitrary 10 mer primers. The products are then separated by electrophoresis followed by staining, ultraviolet visualization and DNA sequencing. Using this method Murakami (2000) produced a dendrogram, based on genetic distance, which resolved most of the common varieties into six clusters; most of the high-alpha hops were in the first cluster.

Table 7.3 Properties of principal hop cultivars^a

Cultivar	α -acid (%)	α/β ratio	Cohumulone (%)	Oil (%)	Humulene/ Caryophyllene ratio	Comments
<i>Australia</i>						
Opal	13.0	3.2	30	1.5	2.5	
Pride of Ringwood ^b	9.0–11.0	1.7	33	2.0	0.1	
Super Pride	13.9	2.4	27	1.0	0.4	
Topaz	11.5	2.0	40	1.0	0.2	
Victoria	11.0–14.0	2.1	38	1.1	1.6	
<i>Belgium</i>						
Record	5.5–8.5	1.0	30	1.8	2.5	
<i>Czech Republic</i>						
Bor	6.5–11	1.8	25	1.5	3.2	Dual
Premiant	7.0–11.0	1.9	22	1.5	3.0	Dual
Saaz	3.0–4.5	0.9	26	0.4	3.5	
Sladek	4.0–8.0	1.0	28	1.5	2.4	Aroma
<i>England^c</i>						
Admiral	13.5–16.2	2.6–3.2	26–32	1.0–1.7		Wilt tolerant
Bramling Cross	6.0–7.8	2.4–3.1	26–31	0.7–1.0	2.2	Wilt tolerant
Brewers Gold	5.5–8.5	1.9	38	1.5	2.3	
Bullion	6.0–9.0	1.9	36	3.2	1.5	
First Gold (Dwarf)	5.6–8.7	2.4–3.2	29–34	0.7–1.4	3.2	Wilt tolerant
Fuggle	3.0–5.6	1.5–2.2	29–30	0.7–1.1	3.3	
Goldings	4.4–6.7	2.1–2.6	26–32	0.8–1.0	3.5	
Herald (Dwarf)	11.0–13.0	2.4	37	1.0–2.2	2.4	Wilt resistant
Northern Brewer	6.5–10.0	2.0	23	2.0	2.8	
Phoenix	12.0–15.0	2.1–2.6	24–28	1.2–2.5		Wilt resistant
Progress	6.0–7.5	2.8–3.3	27–36	0.5–0.8	3.3	Wilt tolerant
Whitbread Golding						
Variety (WGV)	5.4–7.7	2.3–3.0	32–43	0.8–1.2	3.5	Wilt tolerant
Wye Challenger	6.5–8.5	1.8–2.1	20–25	1.0–1.5	3.1	
Wye Northdown	6.8–9.6	1.5–2.2	24–29	1.2–2.2	2.7	
Wye Target	9.9–12.6	2.2–2.8	35–39	1.2–1.4	2.4	Wilt resistant
<i>France</i>						
Strisselspalt	2.0–5.0	1.0	24	0.7	2.4	
<i>Germany^d</i>						
Hallertau mittelfrüh	3.5–5.0	1.0	21	0.6–1.0	3.7	Aroma
Hallertau tradition	5.0–7.0	1.2	26	1.2–1.4	3.8	Aroma
Hersbrucker spät	3.0–5.0	0.9	25	0.6–1.0	2.5	Aroma
Hüller (Bitterer)	5.0–7.0	1.2	30	1.0–1.3	1.9	
Magnum	12.0–14.0	2.6	26	1.6–2.1	3.6	Bitter
Perle	6.0–8.5	1.6	29	1.0–1.3	2.6	Aroma
Spalter	4.0–5.0	1.1	24	0.6–1.0	3.3	
Spalter	4.0–5.5	1.3	24	0.6–1.0	2.0	Aroma
Taurus	12.0–15.0	3.0	24	1.2–1.5	3.7	Bitter
Tettngang	3.5–5.0	1.0	25	0.4–1.0	2.7	Aroma
<i>New Zealand^e</i>						
Green Bullet	12.5–13.5	1.8	42	0.8	3.2	
NZ Hallertau aroma	8.5	1.3	29	1.25	2.0	
Pacific Gem	14.0–16.0	1.8	41	1.5	3.2	
Pacific Hallertau	6.0	1.0	26	1.26	2.9	
Southern Cross	11.0–12.0	1.9	27	1.2	3.4	
Stricklebract	13.5–14.5	1.7	38	1.0	3.2	
Super Alpha	12.5–13.5	1.5	38	1.5	3.2	

Table 7.3 (Continued).

Cultivar	α -acid (%)	α/β ratio	Cohumulone (%)	Oil (%)	Humulene/ Caryophyllene ratio	Comments
<i>Poland^f</i>						
Limbus	5.3	–	36	1.7	2.2	Aroma
Lubekski	4.0	–	31.8	1.2	5.1	Aroma
Lublin	3.5–4.5	1.3	27	1.0	3.7	
Marynka	11.1	–	25	2.3	5.0	Bitter
Oktawia	10.6	–	34	1.6	4.4	Bitter
Sybilla	7.3	–	34	1.7	3.8	Bitter
Zbyszko	8.5	–	26	1.0	2.5	Bitter
<i>Slovenia</i>						
Ahil	8.0–10.0	2.2	27	1.0	2.4	
Apolon	8.0–10.0	2.2	27	1.0	2.5	
Atlas	8.0–10.0	2.2	31	0.8	2.3	
Aurora	8.5–10.5	2.1	25	1.0	2.9	
Bobek	5.7	1.1	33	2.3	3.2	
Blisk	6.0	2.0	37	1.9	2.4	
Buket	8.2	2.3	24	2.7	2.9	
Cekin	5.6	2.2	27	1.3	3.3	
Celeia	5.4	2.1	28	2.1	2.4	
Cerera	5.2	1.7	30	2.0	2.7	
Cicero	8.7	2.9	28	1.5	2.9	
Savinja (Styrian)						
Golding	4.5–6.0	2.0	28	0.8	3.1	
<i>South Africa^g</i>						
Outeniqua	12.0–13.5	2.8	29	1.6	3.0	Bitter
Southern Brewer	9.0–10.5	2.4	39	1.5	2.1	Bitter
Southern Promise	9.5–11.5	2.3	21	0.7	2.4	Dual purpose
Southern Star	12.0–15.5	2.8	31	1.6	1.5	Bitter
<i>United States^h</i>						
Cascade	4.5–7.0	1.0	37	1.2	2.7	
Chelan	14.5	1.4	35	1.5	1.2	
Chinook	12.0–14.0	3.9	32	2.0	2.	
Cluster	5.5–8.5	1.4	36–42	0.4–0.8	2.5	
Columbus/Tomohawk/ Zeus (CTZ)	14–18	3.1	29–34	2.0–3.5	1.7	
Galena	11.0–13.0	1.6	44	0.9–1.4	2.0	
Horizon	13.6	2.2	19	1.9	1.6	Dual
Millenium	15.5	3.2	30	2.0	2.4	
Mount Hood	5.0–8.0	1.1	23	1.1	2.5	
Nugget	12.0–14.0	3.3	27	2.0	2.2	
Willamette	5.0–7.0	1.6	33	1.2	2.9	
YCR-5 (Warrior)	14.5–16.5	2.6	24–26	1.0–2.0	1.9	
<i>Humulus lupulus</i> var. <i>neomexicanus</i>						
	3.1	1.4	65	0.6–0.8	0.73	

^a From Neve (1991) and Darby (personal communication). Neve also gives data for Omega and Yeoman (GB), Orion (D) and Aquila, Banner, Olympic and Talisman (USA).

^b Leggett (2004).

^c National Hop Association of England (2000).

^d Barth (1999).

^e Inglis (1999).

^f Brudzynski and Baranowski (2003).

^g Brits and Linsley-Noakes (2001).

^h www.usahops

7.8 References

- BARTH, S. J. (1999) *Ferment*, **12** (5), 40.
- BARTH, H. J., KLINKE, C. and SCHMIDT, C. (1994) *The Hop Atlas – The History and Geography of the Cultivated Plant*. Barth, Nürnberg, 383 pp.
- BEHRE, K.-E. (1999) *Vegetation History and Archaeobotany*, **8**, 35–48.
- BENITEZ, J. L., FORSTER, A., DE KEUKELEIRE, D., MOIR, M., SHARPE, F. R., VERHAGEN, L. C. and WESTWOOD, K. T. (1997). *European Brewery Convention – Manual of Good Practice: Hops and Hop Products*, pp. xiv + 186. Verlag Hans Carl, Nürnberg.
- BRITS, G. and LINSLEY-NOAKES, G. C. (2001) *Proc. 8th. Conv. Inst. Brewing, Africa Section, Sun City, South Africa*, p. 176.
- BRUDZYNSKI, A. and BARANOWSKI, K. (2003) *J. Inst. Brewing*, **109**, 154.
- BURGESS, A. H. (1964) *Hops: Botany, Cultivation and Utilization*. Leonard Hill, London, pp. xx + 300.
- DE KEUKELEIRE, J., OMMS, G., HEYERICK, A., ROLDAN-RUIZ, I., VAN BOCKSTAELE, E. and DE KEUKELEIRE, D. (2003) *J. Agric. Food Chem.*, **51**, 4436.
- EUROPEAN BREWERY CONVENTION (1987) *Monograph XIII. Symposium on Hops, Weihenstephan*, pp. xii + 286.
- EUROPEAN BREWERY CONVENTION (1994). *Monograph XXI. Symposium on Hops, Zoeterwoude*, pp. xviii + 300.
- EUROPEAN BREWERY CONVENTION (1997) *see Benitez et al.*
- FILMER, R. (1982) *Hops and Hop Picking*, Shire Publications, Princes Risborough, 80 pp.
- GREEN, C. P. (1978) *J. Inst. Brewing*, **84**, 312.
- INGLIS, T. (1999). *Ferment*, **12** (5), 19–28.
- JOHNSTONE, D. I. H. (1997) *Ferment*, **10**, 325–329.
- LEGGETT, G. (2004) *Brewer Intern.*, **4** (2), 42.
- LEMUSIEAU, G., LIÉGEOIS, C. and COLLIN, S. (2001) *Food Chemistry*, **72**, 413.
- LIKENS, S. T., NICKERSON, G. B., HAVOULD, A. and ZIMMERMAN, C. E. (1978) *Crop Sciences*, **18**, 380–386.
- MOIR, M. (2000) *J. Amer. Soc. Brew. Chem.*, **58**, 131–146.
- MURAKAMI, A. (2000) *J. Inst. Brewing*, **106**, 157–161.
- NATIONAL HOP ASSOCIATION OF ENGLAND (2000). *The Hop Guide*, 22 pp.
- NEVE, R. A. (1991) *Hops*. Chapman & Hall, London, xii + 266 pp.
- PICKETT, J. A., COATES, J. and SHARPE, F. R. (1977) *Proc. 16th Congr. Eur. Brew. Conv., Amsterdam*, p. 123; *J. Inst. Brewing*, **83**, 302.
- WILSON, D. G. (1975) *New Phytologist*, **75**, 627–648.

8

The chemistry of hop constituents

8.1 Introduction

Freshly picked hop cones contain about 80% moisture and rapidly go mouldy if not dried on a kiln or oast. Commercial hops contain c. 10% moisture. Moisture in hops is usually measured as the loss on drying at 105–107 °C for 1 hour (*Analytica-EBC*, 1998). For green hops a longer period of drying (four hours) is necessary. Some essential oil may be lost during oven drying. Alternative methods for estimating moisture in hops include drying in a vacuum desiccator or azeotropic distillation (Dean and Stark method). Hop analyses are usually reported ‘as is’ but may occasionally be given with reference to dry matter.

Most of the brewing value of the hop is found in the resins and essential oils which are only slightly soluble in water. However, Goldstein *et al.* (1999) showed that hops contain 20–25% of water-soluble constituents which dissolve directly in the boiling wort. This fraction will include carbohydrates, amino acids, proteins, polyphenols, and inorganic salts. MacWilliam (1953) showed that hops contain c. 2% of sugars mainly fructose, glucose and raffinose; hops also contain 1–2% of pectin. Goldstein *et al.* (1999) drew attention to the presence of glycosides in the water-soluble fraction of hops. Most organisms transport water-insoluble substances by conjugating them with a sugar, usually glucose, to produce a water-soluble glucoside. β -Sitosterol glucoside was found in hops as long ago as 1913 (Power *et al.*, 1913) and many polyphenols are found as glycosides in hops (see later). Goldstein *et al.* (1999) also found that many volatile constituents of hops are also present in the water-soluble fraction bound as glycosides.

Hops contain 2.0–3.5% of nitrogen equivalent to 12.5–21.7% of protein. About 0.5% of the nitrogen, equivalent to 3.1% of protein, is soluble in water. Hops contain c. 0.1% of amino acids and dried hops yield about 8% of ash (inorganic matter). Lipids – oils, fats, and waxes – are, like the hop resins, insoluble in water. Hop seeds contain up to 32% of triglycerides but they are not usually dispersed from intact seeds during wort boiling. Hop wax is derived from the cuticle of cones and leaves and is a mixture of long chain hydrocarbons (C_{29} predominates), alcohols, acids and esters together with β -sitosterol. Although these materials are only slightly soluble in water they may be included with the resins in solvent extracts of hops.

The chemistry of hop constituents was reviewed by Stevens (1967) and Moir (2000) provided a millenium review. Other reviews have concentrated on individual classes of hop compound.

8.2 Hop resins

8.2.1 Introduction

A book, *Chemistry and Analysis of Hop and Beer Bitter Acids* (Verzele and De Keukeleire, 1991) provides a detailed discussion of most of the reactions discussed in this section. Later information is found in the European Brewery Convention Symposium on Hops, Zoeterwoude (1994) and the European Brewery Convention: Manual of Good Practice-Hops and Hop Products (Benitez *et al.*, 1997). The Nomenclature Committee of the Hops Liaison Committee (1969) made recommendations defining A, non-specific fractions and B, specific compounds and mixtures of specific compounds.

A. Non-specific fractions

1. Total resins The part of the hop constituents that is characterized by solubility both in cold methanol and diethyl ether (mainly hard resins, uncharacterized soft resins, α -acids and β -acids). The requirement that the total resins should be soluble in cold methanol is designed to exclude hop wax which will slowly crystallize from cold methanol.
2. Total soft resins The fraction of the total resins that is characterized by solubility in hexane (mainly α -acids, β -acids and uncharacterized soft resins).
3. Hard resins The fraction of the total resins that is characterized by insolubility in hexane. It is calculated as the difference between total resins and total soft resins.
4. β -Fraction The total soft resins minus the α -acids.
5. Uncharacterized soft resins That portion of the total soft resins that has not been characterized as specific compounds.

B. Specific compounds and mixtures of specific compounds

1. The α -acids (8.1). These are mainly humulone (8.1a), cohumulone (8.1b) and adhumulone (8.1c).
2. The β -acids (8.2). These are mainly lupulone (8.2a), colupulone (8.2b) and adlupulone (8.2c).
- 3–8. Chemical descriptions of the α - and β -acid analogues are given in Table 8.1.
9. The iso- α -acids (8.40). These are mainly isohumulone, isocohumulone and iso-adhumulone.
10. Isohumulone (8.40a). The mixture of *cis*- and *trans*-isohumulone. Similarly, isocohumulone (8.40b) refers to a mixture of *cis*- and *trans*-isocohumulone and iso-adhumulone (8.40c) to a mixture of *cis*- and *trans*-iso-adhumulone,
11. *cis*-Isohumulone (8.43). The iso- α -acid with the empirical formula $C_{21}H_{30}O_5$. It is an oil with the higher partition coefficient in a phase system of a hydrocarbon and a buffer, and contains an isovaleryl side chain. *Cis*- means that the 3-methyl-2-butenyl side chain and the tertiary hydroxyl group are on the same side of the ring.
12. *trans*-Isohumulone (8.44). The iso- α -acid with the empirical formula $C_{21}H_{30}O_5$, with a m.p. 72°C and the lower partition coefficient in a phase system of a hydrocarbon and a buffer, and contains an isovaleryl side chain. *Trans*-means that

- the 3-methyl-2-butenyl side chain and the tertiary hydroxyl group are on opposite sides of the ring.
13. *cis*-Isocohumulone. As in 11 but with reference to $C_{20}H_{28}O_5$ and an isobutyryl ($R = Pr^i$) side chain.
 14. *trans*-Isocohumulone. As in 12 but with reference to $C_{20}H_{28}O_5$ and an isobutyryl side chain.
 15. *cis*-Isoadhumulone. As in 11 but with reference to a 2-methylbutyryl ($R = CHMeEt$) side chain.
 16. *trans*-Isoadhumulone. As in 12 but with reference to a 2-methylbutyryl side chain.
 17. *Allo*-Iso- α -acids (**8.41**). These are isomers of the iso- α -acids having a shifted double bond in the isohexenoyl side chain (i.e. 4-methyl-2-pentenyl). Of each *allo*-iso- α -acid there is a *cis*- and a *trans*- form. The following specific names are therefore proposed: *cis*-allo-isohumulone, *trans*-allo-isohumulone, *cis*-allo-isocohumulone, *trans*-allo-isocohumulone, *cis*-alloisoadhumulone and *trans*-allo-isoadhumulone.
 18. Hulupones (**8.85**). These consist of hulupone, cohulupone and adhulupone.
 19. Hulupone (**8.85a**). Has the empirical formula $C_{20}H_{28}O_4$. It is 2,2-di[3-methyl-2-butenyl]-5-isovaleryl-1,2,4-cyclopentanetrione and is formed from lupulone.
 20. Cohulupone (**8.85b**). As in 19 but with reference to $C_{19}H_{26}O_4$ and a 5-isobutyryl side chain.
 21. Adhulupone (**8.85c**). As in 19 but with reference to $C_{20}H_{28}O_4$ and a 5-[2-methylbutyryl] side chain.
 22. Humulinic acids (**8.3**). These consist of the *cis*- and *trans*- forms of humulinic acid, cohumulinic acid and adhumulinic acid.
 23. *cis*-Humulinic acid. Has the empirical formula $C_{15}H_{22}O_4$ with m.p. 68 °C and the higher partition coefficient in a phase system of a hydrocarbon and a buffer. *Cis*-means that the 3-methyl-2-butenyl side chain and the alcoholic hydroxyl are on the same side of the ring.
 24. *trans*-Humulinic acid. Has the empirical formula $C_{15}H_{22}O_4$ with m.p. 95 °C and the lower partition coefficient in a phase system of a hydrocarbon and a buffer. *Trans*-means that the 3-methyl-2-butenyl side chain and the alcoholic ring hydroxyl group are on opposite sides of the ring. Similar considerations will apply to *cis*-cohumulinic acid, *trans*-cohumulinic acid, *cis*-adhumulinic acid and *trans*-adhumulinic acid.

The sub-committee also recommended that where the intention is to refer to 'beer bitter substances', usually an incompletely known mixture, this phrase should be used. Using these definitions the bulk of the brewing and bittering value of the hop is found in the total soft resins and, in particular, in the α -acids. Only traces of the α -acids survive into beer; they are transformed during wort boiling into the iso- α -acids which are the major bittering principles of beer. The importance of the *allo*-iso- α -acids is still debatable. The β -acids are too insoluble in water to contribute to beer flavour themselves but they can be oxidized into hulupones which are bitter and are minor bittering principles in some beers. Hydrolysis of the α -acids and the iso- α -acids gives a mixture of humulinic acids which are not bitter. The humulinic acids are not normally found in beer but they may be present in some isomerized hop extracts and beers brewed therefrom.

The α -acids can be separated from the total soft resins by their ability to form an insoluble lead salt (chelate?) with lead(II) acetate in methanol; the β -fraction may be recovered from the mother liquors. The α -acids can be regenerated from the lead salts by

suspending them in methanol and adding either sulphuric acid or hydrogen sulphide gas. After removal of the inorganic matter by filtration, evaporation of the solvent leaves a mixture of α -acids from which humulone may slowly crystallize. Humulone (**8.1a**) was the only α -acid known until 1953 when Rigby and Bethune isolated the analogues cohumulone (**8.1b**) and adhumulone (**8.1c**) by countercurrent distribution. Traces of other analogues have been found (Table 8.1). Later, Hermans-Lockkerbol and Verpoorte (1994) used centrifugal partition chromatography to separate the α -acids. Most hop varieties contain about 10% of adhumulone in their α -acids but the proportion of cohumulone appears to be a varietal characteristic (Table 7.3). The α -acids form crystalline 1:1 complexes with 1,2-diaminobenzene (*o*-phenylenediamine). Repeated recrystallization concentrates the humulone complex with respect to those of the other α -acids. Decomposition of the yellow complex with 2*N*-hydrochloric acid followed by recrystallization from cyclohexane at -20°C gives humulone, m.p. 63°C . Most of the chemistry of the α -acids has been carried out on humulone purified in this way but Simpson (1993a) found that a sample prepared in this manner still contained 8% of cohumulone and 1% of adhumulone.

The β -acids (**8.2**) may crystallize from the β -fraction obtained after the lead salts have been precipitated. In practice it may be better to dilute the methanol solution with brine and extract the β -fraction into light petroleum. Alternatively, a solution of a hop extract in hexane may be extracted first with disodium carbonate, to remove the stronger α -acids, and then with sodium hydroxide to recover the β -acids. From the mixture of β -acids Lerner isolated lupulone (**8.2a**) in 1863. Much later, in the 1950s, it was found that the β -acid which crystallized from English hop extracts was colupulone (**8.2b**). Thus, like the α -acids, the β -acids are a mixture of analogues. They are too sensitive to aerial oxidation to be separated by countercurrent distribution. They can be separated by HPLC, but before this technique was available, the proportions of the β -acid analogues was found by converting them to tetrahydro- α -acids (**8.9**, Fig. 8.1) which were stable during countercurrent distribution. It was found that the β -acids were always richer in colupulone than the α -acids were in cohumulone. Indeed a regression equation was obtained:

$$\% \text{ Colupulone in } \beta\text{-acids} = 0.943 (\% \text{ cohumulone in } \alpha\text{-acids}) + 20.2$$

The structures of humulone (**8.1a**) and lupulone (**8.2a**), except in minor detail, were worked out by Wollmer and Wieland (Fig. 8.1). Both are acylphloroglucinols substituted with 3-methyl-2-butenyl- (dimethylallyl- or isoprenyl-) groups, three in lupulone and two in humulone, which also has a tertiary hydroxyl group. Hydrolysis of humulone, $\text{C}_{21}\text{H}_{30}\text{O}_5$, gives humulinic acid (**8.3a**), $\text{C}_{15}\text{H}_{22}\text{O}_4$, and 4-methyl-3-pentenoic acid (isohexenoic acid, (**8.13**)), $\text{C}_6\text{H}_{10}\text{O}_2$, which accounts for all the carbon atoms, but isobutyraldehyde (**8.14**) is also formed. Hydrogenation of humulinic acid gave dihydrohumulinic acid (**8.4a**) which by Clemmensen reduction gave 1,3-di-isopentylcyclopentane (**8.11**) establishing the five-membered ring in humulinic acid. Mild hydrogenation of humulone gave the tetrahydro-derivative (**8.13a**), showing two double bonds, but with palladium chloride hydrogenolysis occurs giving humuloquinol (**8.5a**), $\text{C}_{16}\text{H}_{24}\text{O}_5$, which is readily oxidized to humuloquinone (**8.6a**). Hydrolysis of humuloquinone gives isohumulinic acid (**8.7a**) also obtained from dihydrohumulinic acid (**8.4a**) by oxidation with bismuth oxide. Similarly, mild hydrogenation of lupulone (**8.2a**) gives a hexahydro-derivative but hydrogenolysis gives tetrahydrodeoxyhumulone (**8.8a**) which, when shaken in air or oxygen with lead acetate solution, gives the lead salt of tetrahydrohumulone (**8.9a**) linking the α - and β -acids.

Table 8.1 Analogues of the α - and β -acids

α -acids						β -acids		
Acyl side chain (R)	Name	Formula	m.p. (°C)	$[\alpha]_D^{24}$	pKa	Name	Formula	m.p. (°C)
a -CO.CH ₂ .CH(CH ₃) ₂ isovaleryl	Humulone	C ₂₁ H ₃₀ O ₅	64.5°	-211°	5.5	Lupulone	C ₂₆ H ₃₈ O ₄	92°
b -CO.CH(CH ₃) ₂ isobutyryl	Cohumulone	C ₂₀ H ₂₈ O ₅	oil	-208.5°	4.7	Colupulone	C ₂₅ H ₃₆ O ₄	93-94°
c -CO.CH(CH ₃).CH ₂ .CH ₃ 2-methylbutyryl	Adhumulone	C ₂₁ H ₂₈ O ₅	oil	-187°	5.7	Adlupulone	C ₂₆ H ₃₈ O ₄	82-83°
d -CO.CH ₂ .CH ₃ propionyl	Posthumulone ^a	C ₁₉ H ₂₆ O ₅	oil	-	-	^d	C ₂₄ H ₃₄ O ₄	101°
e -CO.CH ₂ .CH ₂ .CH(CH ₃) ₂ 4-methylpentanoyl	Prehumulone ^b	C ₂₂ H ₃₂ O ₅	oil	-172°	-	^e	C ₂₇ H ₄₀ O ₄	91°
f -CO.(CH ₂) ₄ .CH ₃ hexanoyl	Adprehumulone ^c	C ₂₂ H ₃₂ O ₅	-	-	-	^e	C ₂₇ H ₄₀ O ₄	90°
g -CO.CH ₂ .CH ₂ .CH(CH ₃).CH ₂ .CH ₃ 4-methylhexanoyl	-	C ₂₃ H ₃₄ O ₅	-	-	-	-	C ₂₈ H ₄₂ O ₄	91°

^a Verzele (1958).^b Rillaers and Verzele (1962).^c Smith *et al.* (1998).^d Riedl *et al.* (1956).^e Riedl (1954).

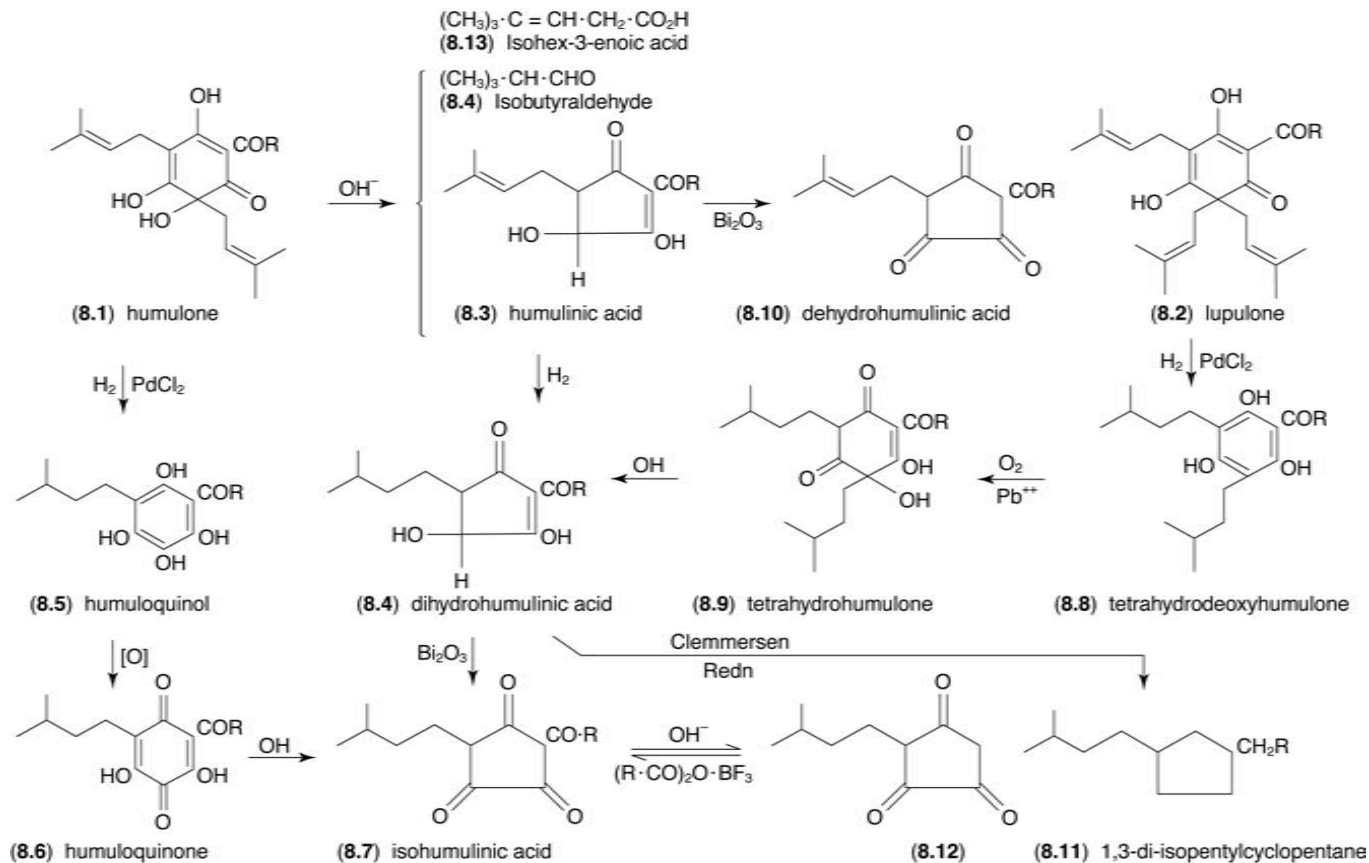
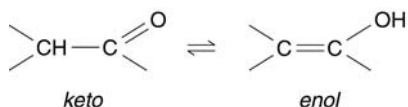

Fig. 8.1 Reactions of α - and β -acids.

In both humulone (**8.1a**) and lupulone (**8.2a**) carbon atom-6 in the ring is sp^3 hybridized; the other atoms in the ring are sp^2 hybridized. In humulone carbon atom-6 is substituted by four different groups and so it is chiral and humulone is optically active. The natural α -acids are laevorotatory and their specific angular rotations are given in Table 8.1. Using the sequence rules of Cahn *et al.* (1951, 1956 and 1966) the absolute stereochemistry of the α -acids is *R(ectus)* so natural humulone is *R*-(-)-humulone. Synthetic racemic humulone is an equimolecular mixture of *R*-(-)-humulone and unnatural *S*-(+)-humulone and, as such, will not rotate the plane of polarized light. Fairly mild chemical treatment will convert *R*-(-)-humulone into racemic *RS*-(\pm)-humulone. (\pm)-Humulone has not been resolved into its enantiomers but this should be possible.

In lupulone (**8.2a**) and the other β -acids carbon atom-6 is substituted with two 3-methyl-2-butenyl- (isoprenyl-) groups so it will not be chiral and will not rotate the plane of polarized light. However, in adlupulone (**8.2c**) there is a chiral centre at C-2 of the 2-methylbutyryl-side chain so natural adlupulone should be optically active. It follows that natural adhumulone (**8.1c**) has two chiral centres so four enantiomers are possible. By analogy with *L*-isoleucine, the 2-methylbutyryl-side chain in natural adhumulone and adlupulone probably has the *S*-configuration.

It is difficult to write a single structure for most of the hop resins because they exhibit keto-enol tautomerism where ketones exist in equilibrium with the related enol:



With an isolated ketone, as in acetone (**8.15**), the equilibrium lies well on the ketone side:



(8.15) acetone

However, β -dicarbonyl compounds such as acetylacetone (pentane-2,4-dione, (**8.16**)) exist largely in the enol form which is stabilized by hydrogen bonding.

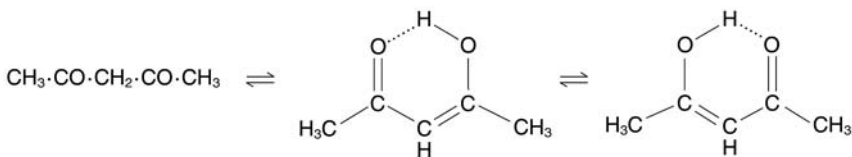

(8.16) acetylacetone

Even more tautomers can be drawn for β -tricarbonyl compounds such as triacetyl-methane (**8.17**)



(8.17) triacetyl methane

Most of the hop resins contain β -di- or β -tricarbonyl systems which are enolized. In most cases the individual tautomers cannot be isolated but it is usually possible to estimate the proportions of the individual tautomers by proton magnetic resonance spectroscopy (PMR) or other physical methods. Irrespective of the main component of a tautomeric

mixture it can react both as a ketone and as an enol. It is an equilibrium mixture so that if one component is removed by reaction it will be regenerated according to the equilibrium. Thus, for example, phloroglucinol, the parent of the hop resins, exists almost entirely in the trienol form (**8.18**) and can form a triacetate (**8.20**) but it can react as cyclohexane-1, 3, 5-trione (**8.19**) to produce a tri-oxime (**8.21**).

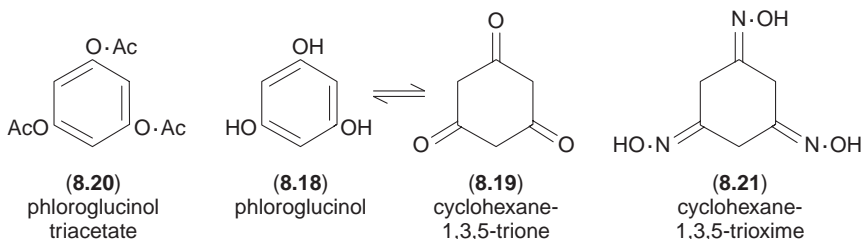

PMR measurements show that humulone exists principally as a dienol. Of the possible tautomeric structures (**8.1.1–4**), structure (**8.1.1**) is thought to represent the major tautomer; structures (**8.1.2**) and (**8.1.4**) were excluded on the basis of optical rotatory dispersion measurements and (**8.1.1**) was preferred over (**8.1.3**) by comparison with model compounds (De Keukeleire and Verzele, 1970).

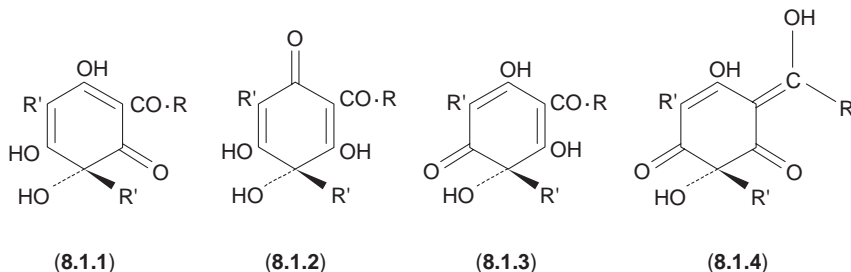

Similarly, PMR measurements suggest that lupulone exists as a mixture of two tautomers (**8.2.1**) and (**8.2.2**) in the ratio 7:3 (Collins *et al.*, 1971).

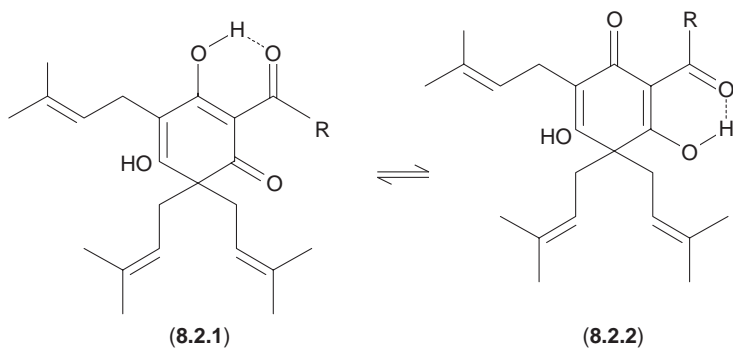

Consideration of the tautomers of acetylacetone (**8.16**) shows that the enol hydrogen atom is bound to different oxygen atoms in the two cyclic forms. This hydrogen can dissociate leaving an enolate ion stabilized by resonance. Thus, β -di- and β -tri-carbonyl compounds are acids and these functions provide the acidity of the hop resins. The strength of acids can be compared on the pKa scale where

$$\text{pKa} = -\log_{10} \text{Ka}$$

and K_a is the dissociation constant of the acid. On this scale completely dissociated mineral acids have negative values while carboxylic acids have values such as: methanoic (formic) acid, pK_a 3.77, ethanoic (acetic) acid, pK_a 4.76, propanoic acid, pK_a 4.88, and benzoic acid, pK_a 4.20. Triacetylmethane (**8.17**), pK_a 5.81, is a stronger acid than acetylacetone (**8.16**) pK_a 8.13, while phenol, pK_a 10.0, is weaker still. Phloroglucinol (**8.18**) has three phenolic hydroxy groups; the pK_a s of the first two are 7.97 and 9.23.

pK_a measurements should be made in dilute aqueous solution but, because of their limited solubility, early estimates of the pK_a s of the hop resins were made in aqueous methanol solutions giving pK_a values for humulone, 5.5, cohumulone, 4.7, and adhumulone, 5.7. In aqueous solutions Simpson and Smith (1992) found equilibrium pK_a values for the most acidic functions were: humulone, 5.0, colupulone (**8.2b**), 6.1, *trans*-isohumulone (**8.44**), 3.1; and *trans*-humulinic acid (**8.3a**), 2.7. Thus, the α - and β -acids are weaker than carboxylic acids, such as acetic acid, but their isomerization products, the *iso*- α -acids, are stronger. It should be recalled that when the pH of the medium equals the pK_a of the acid 50% of the acid will be present as the anion and 50% undissociated.

The solubilities of humulone, lupulone and (*trans*-)humulinic acid were measured by Spetsig (1955) (Fig. 8.2). As expected, the solubilities increase with temperature and increasing pH; in each case the anion is more soluble than the undissociated acid. For example, in boiling wort at pH 5.0, about 200 mg/litre of humulone will dissolve but, if no transformation takes place, most of this will be precipitated from conditioned beer (pH 4.0) at 0°C.

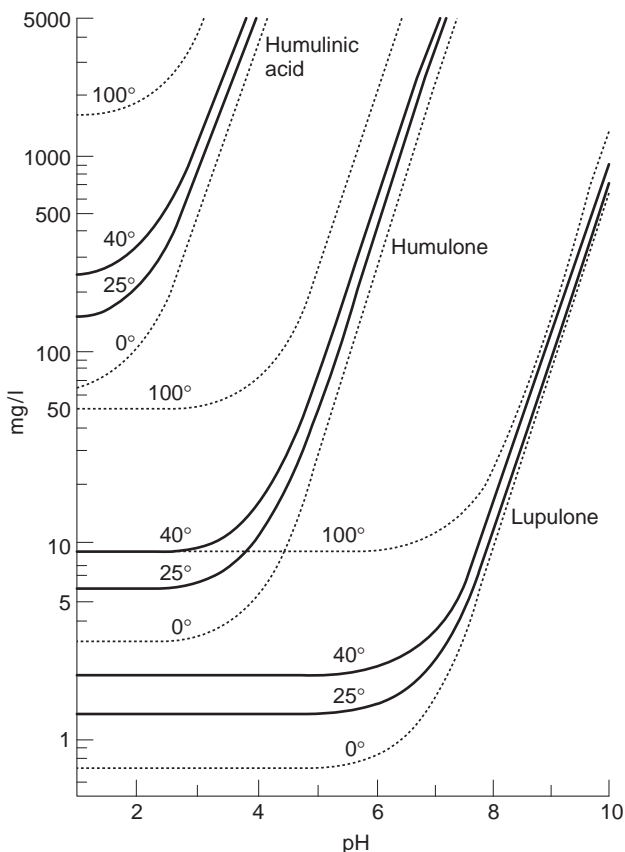
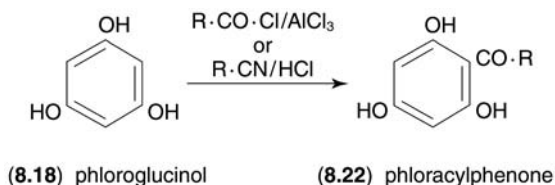
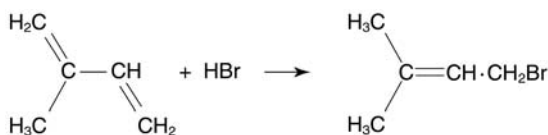

Fig. 8.2 Solubilities of humulinic acid, humulone and lupulone (Spetsig, 1955).

The structure of the α - and β -acids have been verified by synthesis. Acylation of phloroglucinol (**8.18**) gives the parent phloracylphenone (**8.22**); phlorisovalerophenone (**8.22a**) for humulone and lupulone and phlorisobutyrophenone (**8.22b**) for cohumulone and colupulone, etc.



This can be alkylated with 3-methyl-2-butenyl bromide (**8.24**) (isoprene hydrobromide, dimethylallyl bromide), which is prepared by the 1,4-addition of hydrogen bromide to isoprene (**8.23**).



(8.23) isoprene

(8.24) 3-methyl-2-butenyl bromide

Alkylation of phloracylphenone (**8.22**) can give a mixture of one mono- (**8.25**), two di- (**8.26** and **8.27**), one tri- (**8.28**) and one tetra- (**8.29**) isoprenyl derivative.

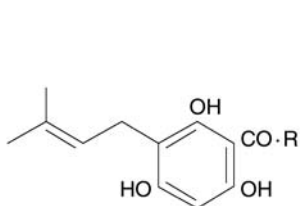
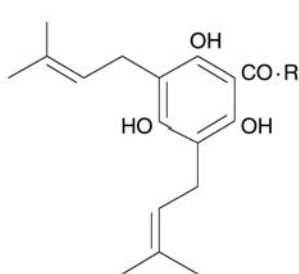
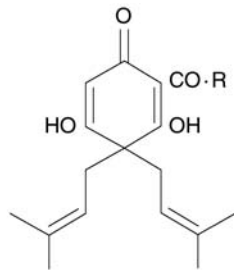
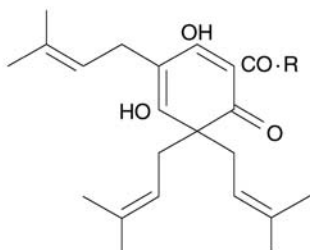
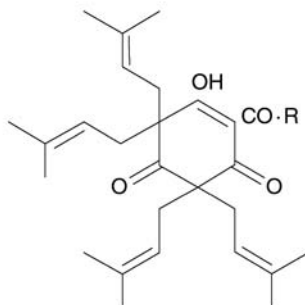
(8.25)
monoprenylphloracylphenone(8.26)
deoxy- α -acids(8.27)
gem-diprenylphloracylphenone(8.28) β -acids

(8.29) lupones

The tri-substituted derivatives are the β -acids (**8.2**), the di-substituted derivatives (**8.26**) the deoxy- α -acids; these and the monosubstituted derivatives (**8.25**) have been found in hops but neither the di-substituted derivative (**8.27**) nor the tetra-substituted derivative (**8.29**, lupones) have been found to occur naturally. With one molecule of base and 3-methyl-2-butenyl bromide the mono-substituted derivatives (**8.25**) can be obtained in good yield and in liquid ammonia the β -acids (**8.28**) are obtained in up to 70% yield (Collins *et al.*, 1971) but the synthesis of the the deoxy- α -acids (**8.26**), and thus the α -acids is more difficult. In the original synthesis of (\pm)-humulone (Riedl, 1951) the overall yield was only 5.7%. Here the deoxyhumulone was oxidized to the lead salt of (\pm)-humulone with oxygen in the presence of lead (II) acetate.

Slightly better yields of deoxy- α -acids were obtained using the weakly basic ion-exchange resin DeAcidite H-IP (OH form) (Collins and Laws, 1973) and by using 3-methyl-buten-3-ol with boron trifluoride-etherate as the alkylating agent (Collins and Shannon, 1973). Deoxy- α -acids (**8.26**) have also been prepared by the irradiation of β -acids with ultraviolet light (Fernandez, 1967). Better yields of α -acids from deoxy- α -acids are found when the autoxidation is carried out in the presence of triethyl phosphite (Sigg-Grutter and Wild, 1974). Without this reducing agent the intermediate hydroperoxide was isolated. Even with the optimal yields reported (Pfenninger *et al.*, 1975) synthetic racemic α -acids are unlikely ever to be as cheap as the naturally produced enantiomers from the hop.

8.2.2 Biosynthesis of the hop resins

The biosynthesis of the hop resin (Fig. 8.3) within the plant is thought to follow a similar route to the chemical synthesis. When $\text{CH}_3^{14}\text{CO}_2\text{Na}$ was injected into a ripening hop plant the labelling of the radioactive humulone suggested that the phloroglucinol nucleus was made up from three acetate units. The acyl side chains were derived from amino acids or intermediates in their biosynthesis. Thus humulone and lupulone come from a leucine metabolite, cohumulone and colupulone from a valine metabolite and the ad-analogues from isoleucine (with aromatic amino acids the prenylflavanoids are formed, see Section 8.2.5). Transamination and decarboxylation of the amino acids leads to the Coenzyme A esters of isovaleric, isobutyric and 2-methylbutyric acids (**8.30**). These are thought to react with three molecules of malonyl Coenzyme A (**8.31**) to give the polyketide (**8.32**) which with an enzyme similar to chalcone synthetase forms the phloracylphenone (**8.22**) (Fung *et al.*, 1997). This with dimethylallyl pyrophosphate (**8.34**) and with the enzyme(s) prenyltransferase(s) forms the mono-prenyl derivative (**8.25**), the deoxy- α -acids (**8.26**) and, probably, the β -acids. Oxidation of the deoxy- α -acids gives the required α -acids (**8.1**).

Since the 1950s it has been thought that dimethylallyl pyrophosphate (**8.34**), the parent of the isoprenoids, terpenoids and steroids, was formed via mevalonic acid (**8.35**) (see Fig. 8.4 Pathway A) and that this was the only route to these compounds. Now, an alternative route, via 1-deoxyxylulose-5-phosphate (**8.37**), has been found (Eisenreich *et al.*, 1998, Fig. 8.4 Pathway B). Goese *et al.*, 1999) have shown that the isoprenyl- side chains of humulone are formed by this latter route and that the biosynthesis of humulone goes through a symmetrical intermediate. According to the new pathway, glyceraldehyde 3-phosphate, produced from glucose by the normal Embden-Meyerhof-Parnas pathway (Fig. 12.7) condenses with 'active acetaldehyde' (**8.36**), produced from pyruvate and thiamine, to give D-1-deoxyxylulose 5-phosphate (**8.37**). This re-arranges, *via* 2-C-methylerythrose (**8.38**) and 2-C-D-erythritol 4-phosphate (**8.39**) to isopentenyl pyropho-

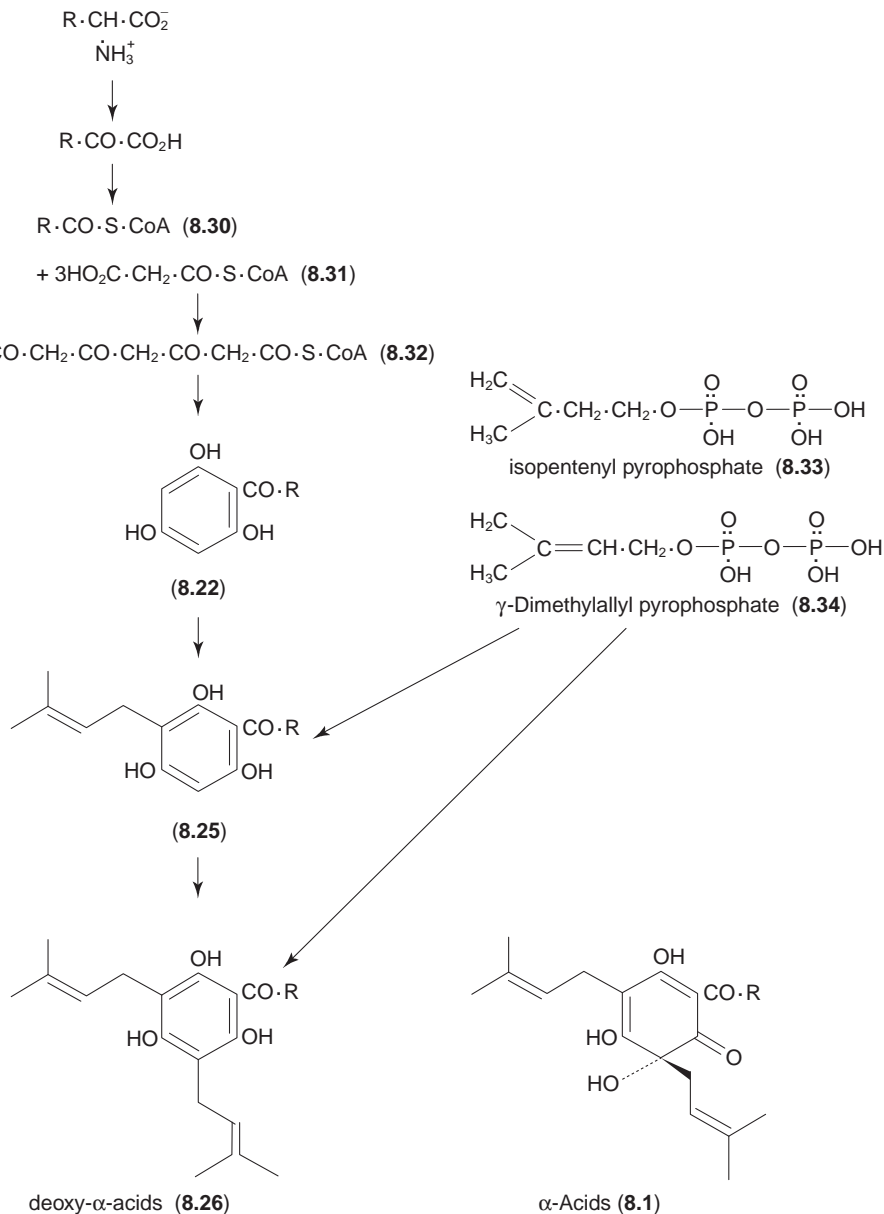
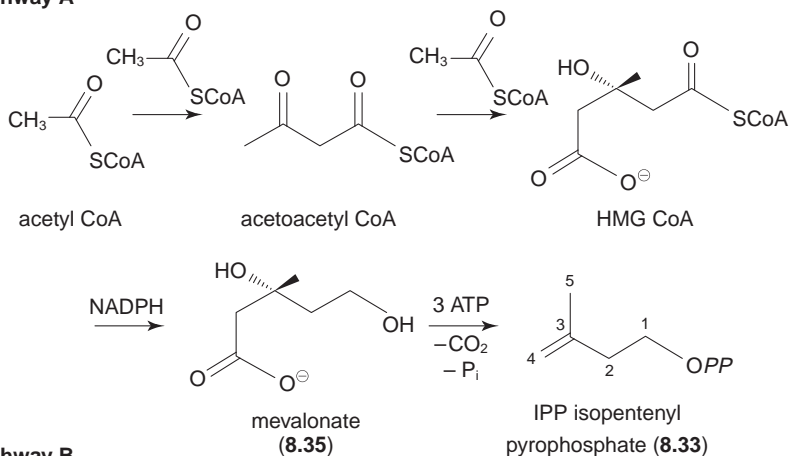

Fig. 8.3 Biosynthesis of the α -acids.

sphate (8.33). This with an isomerase is converted into dimethylallyl pyrophosphate (8.34) which is thought to be the biological isoprenylating agent. Isopentenyl pyrophosphate (8.33) and dimethylallyl pyrophosphate (8.34) can condense together to form, first, geranyl pyrophosphate (8.88), the parent of the monoterpenes, and then farnesyl pyrophosphate (8.105), the parent of the sesquiterpenes, both of which are important constituents of the essential oil (see later). From the limited data available (Eisenreich *et al.*, 1998) it appears that both the mevalonic acid (8.35) and the deoxyxulose pathways (Fig. 8.4) are found in most higher plants. Steroids are mainly formed

Pathway A



Pathway B

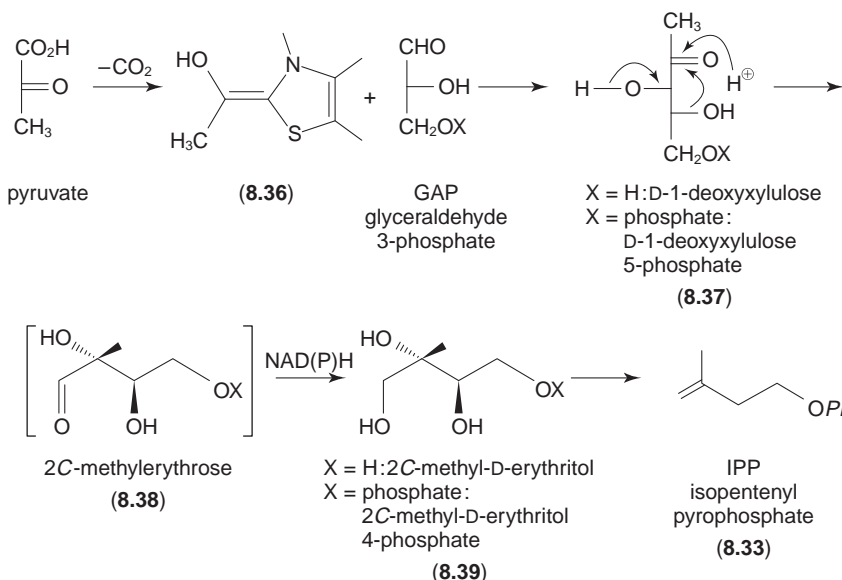

Fig. 8.4 Isoprenoid biosynthesis: (A) via the mevalonate pathway, (B) via the glyceraldehyde 3-phosphate/pyruvate pathway (Rohmer, 1998).

by the mevalonate pathway but isoprene and the essential oil constituents arrive by the deoxy-xyulose pathway.

8.2.3 Analysis of the hop resins

Procedures for the estimation of the total resins, total soft resins, and hard resins, by difference, (see definitions above) in hops and hop products are given in *Analytica-EBC* but since it was found that the α -acids are the most important brewing principles few brewers bother to measure the total and soft resin contents. The α -acids were originally estimated gravimetrically as their lead salts but since the precipitate is soluble in excess of the lead acetate reagent, trials had to be made so that only the correct amount of

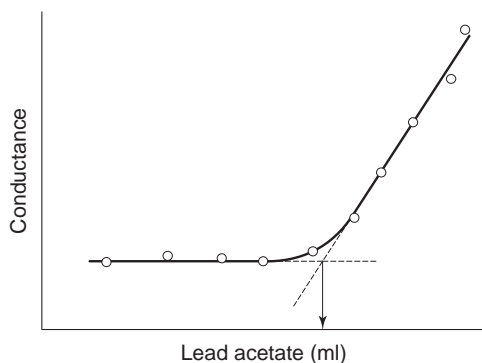

Fig. 8.5 Conductometric titration of α -acids.

reagent was used making it a lengthy process. It was found that if the conductivity of a methanolic solution of the α -acids was measured during titration with methanolic lead acetate solution it did not increase until there was an excess of the reagent. Thus if regular aliquots (0.20 ml) of the methanolic lead acetate reagent (2 or 4%) are added and the conductivity measured after each addition, a graph can be drawn where the intersection of the two straight portions provides the endpoint (Fig. 8.5). The absolute value of the conductivity is not needed and the lead acetate reagent can be standardized by a similar titration against 0.100 *N* sulphuric acid. The shape of the graph is different in the presence of other solvents, so, in the approved method, pyridine (1 ml) is added to the titration. The conductivity may be plotted against the volume of the reagent on Cartesian coordinate paper (Fig. 8.5) or the resistance may be plotted directly on to reciprocal ruled paper. Since the reaction of lead acetate is not specific for α -acids, the result is expressed as the Lead Conductance Value (LCV). However, with fresh hops the LCV is very similar to the α -acid content but, as hops age on storage, oxidation products are formed which may react with lead acetate.

The α -acids are the only hop resins which show significant optical activity ($[\alpha]_D^{20} -237^\circ$ in hexane) so they can be estimated in the soft resins by polarimetry but this method has not been officially adopted.

Alderton *et al.* (1954) measured the light absorption of humulone and lupulone under both acid and alkaline conditions (Fig. 8.6). In particular, they measured in alkaline solution the Absorbance (A) at 275 nm (λ_{\min} for both humulone and lupulone), 325 nm (λ_{\max} for humulone) and 355nm (λ_{\max} for lupulone) and produced regression equations to determine both humulone and lupulone. This method was adopted by the ABSC when:

$$\alpha\text{-acids, \%} = d \times (-51.56 A_{355} + 73.79 A_{325} - 19.07 A_{275})$$

$$\beta\text{-acids, \%} = d \times (55.57 A_{355} - 47.59 A_{325} + 5.10 A_{275})$$

where d is the dilution factor.

These regression equations contain large multiplying factors so the procedure requires a high degree of precision in instrument calibration and the purity of the solvents. This was the first method to give values for the % β -acids. The assumption that the solution of hop resins is a binary mixture of α - and β -acids with constant background absorption is probably true with fresh hops but not with deteriorated samples. Indeed, Likens *et al.* (1970) using this method proposed that the ratio

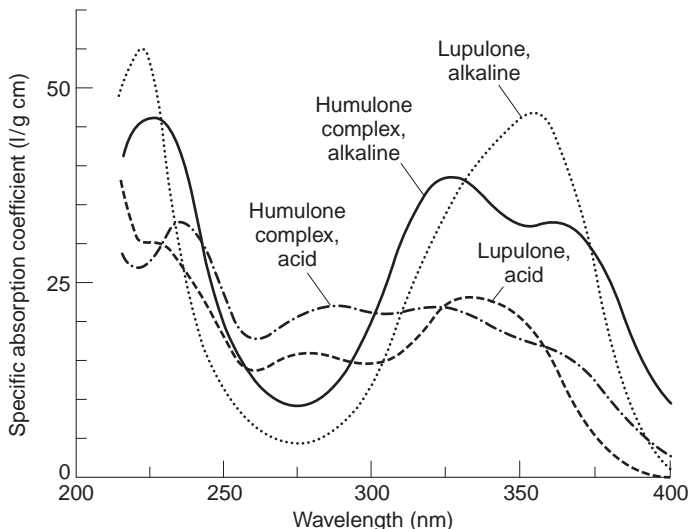

Fig. 8.6 Absorption spectra of lupulone and humulone complex in acidic (0.002 N) and alkaline (0.002 N) methanol (Alderton *et al.*, 1954). Copyright (1954) American Chemical Society.

$$A_{275}/A_{325} = \text{Hop Storage Index (HSI)}$$

was found to increase from c. 0.24 in fresh hops to c. 2.5 in completely oxidized lupulin. The measurement has been adopted by the ASBC. For more precise analysis some method of separation is necessary before measurement. Methods based on Dowex and Sephadex ion-exchange resins have now been archived and replaced by an internationally agreed HPLC method using a 250 × 4 mm, 5 μm RP18 Nucleosil C19 column. The chromatogram usually shows four peaks: cohumulone, humulone + adhumulone, colupulone and lupulone + adlupulone. Other systems will resolve humulone and adhumulone but it remains difficult. Verzele and De Keukeleire (1991) describe HPLC of an ethanolic extract of hops using two coupled columns with diode array detection when sixty peaks could be recognized including 10 α-acids, 10 iso-α-acids, and 11 deoxy-α-acids. The occurrence of iso-α-acids (2.7%) in an ethanolic extract of hops is noteworthy.

8.2.4 Isomerization of the α-acids

As long ago as 1925 it was suggested that the hydrolysis of humulone (8.1) to humulinic acid (8.3) proceeded via an intermediate (8.40, Fig. 8.7). Later this structure (8.40) was given to the bitter-tasting oil obtained by boiling humulone with *N*/15 (0.067 *M*) sodium hydroxide solution for three minutes (Windisch *et al.*, 1927). It was originally called 'Resin A' but later the name 'isohumulone' was adopted for the parent of the iso-α-acids. The iso-α-acids are much more soluble in water (c. 120 mg/l) than the α-acids (3 mg/l) and according to Peacock (1998) nine times more bitter. To account for the formation of isobutyraldehyde (8.14), a second pathway leading to 8.14 and 'Resin B' (4-acetylhumulinic acid, 8.42) was proposed. Later the products of this second pathway were thought to be formed via allo-iso-α-acids (8.41). However, only 4.5% of allo-iso-α-acids were formed in boiling wort but better yields were found at pH 9.0. Less than 1 mg/l were found in beer. So the iso-α-acids, isohumulone, isocohumulone and isoadhumulone (8.40) are the major bittering principles in beer.

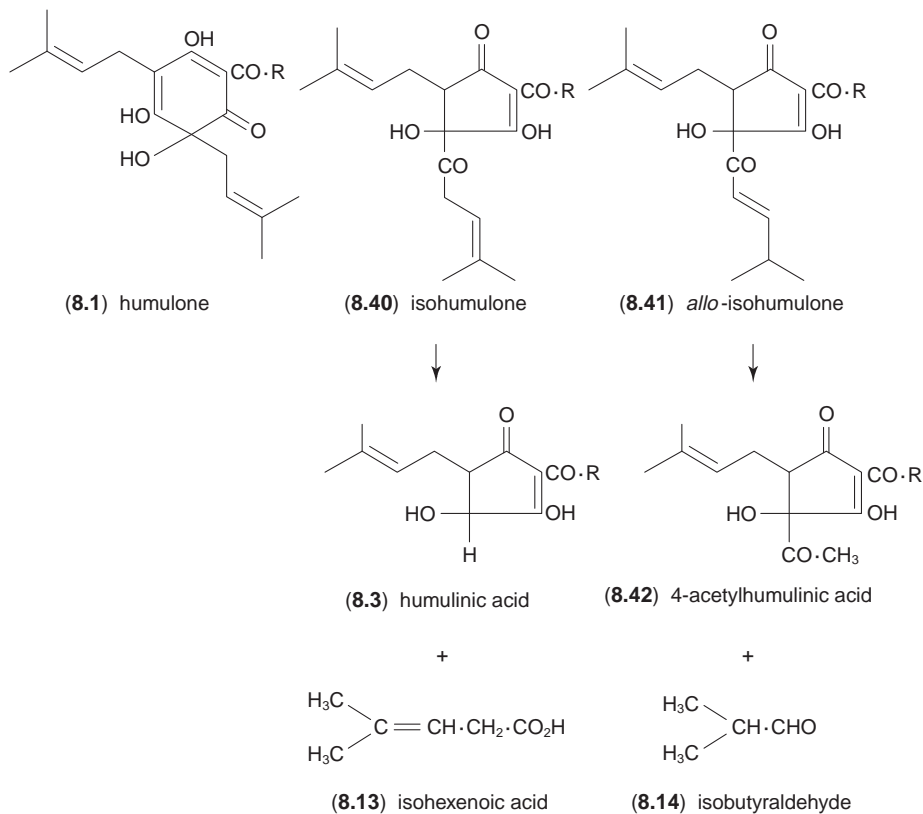

Fig. 8.7 Isomerization and hydrolysis of humulone ($R = \text{Bu}^i$ without stereochemistry).

They are usually estimated by the light absorption of a solvent extract. In the internationally agreed method degassed, acidified beer (10 ml) is extracted with iso-octane (2,2,4-trimethylpentane) (20 ml) and, after centrifugation, the absorbance of the iso-octane layer is read at 275 nm in a 1 cm cell against an iso-octane blank. This is a modification of the method of Moltke and Meilgaard (1955) who gave a regression equation to present results as 'isohumulones' mg/l. In order to avoid assumptions about the chemical nature of the bittering principles in beer, the EBC Analysis Committee simplified the regression equation and gave the results in Bitterness Units (BU):

$$\text{Bitterness Units (BU)} = 50 \times \text{absorbance}$$

With worldwide adoption they are sometimes called International Bitterness Units (IBU). Most commercial beers contain 10–50 BU but exceptional beers with up to 100 BU have been reported (Glaser, 2002). Rigby and Bethune (1955) estimated the iso- α -acids in an iso-octane extract of beer by measuring the light absorption at 255 nm after dilution with alkaline methanol. Beers produced by conventional wort boiling contain only traces of α -acids or humulinic acids which would interfere with the above two methods. However, worts, isomerized hop extracts and beers brewed therefrom may contain such impurities so accurate values for the iso- α -acids can be obtained only after a suitable separation technique. Originally countercurrent distribution was the method of choice but HPLC is more likely to be used today.

Having established that the α -acids are isomerized into iso- α -acids during wort boiling and that the iso- α -acids are the main bittering principles in beer, hop utilization can be defined as:

$$\% \text{ Hop utilization} = \frac{\text{Amount of iso-}\alpha\text{-acids in beer}}{\text{Amount of } \alpha\text{-acids in hops used}} \times 100$$

In conventional wort boiling only about 50% of the α -acids available in the hops go into solution and further losses on to the break and on to the yeast during fermentation occur so that the overall utilization into beer will seldom exceed 40% and may be as low as 10%. In wort boiling higher utilization occurs with weak worts and low levels of hopping. Indeed, the solubility of humulone (and other α -acids) is a limiting factor in utilization (Fig. 8.2). Only 50–60% of pure humulone was isomerized during a 1.5 h boil while with the same amount of α -acids in hops 65–75% were utilized in the same period. Pure humulone in boiling wort forms an oily layer or droplets of minimal surface area and the utilization is improved when the resin is spread over an inert surface such as hops, break, or even Celite. Utilization is also improved at higher pH values but only small variations are possible in wort. However, if the α -acids are isolated from the hops, isomerized at higher pH values and then added to the beer after fermentation much better utilization is obtained.

Many brewers now use such isomerized extracts. Some brewers will use low levels of hops in the copper, with improved utilization, and then achieve the desired bitterness by addition of isomerized extracts after fermentation, others will depend entirely on post-fermentation additions. The isomerized extract must not contain any β -acids as they would be precipitated in the beer necessitating a further filtration with loss of iso- α -acids. Many patents exist for the preparation of isomerized extracts. For example, the α -acids may be extracted from a solvent (ethanol or CO₂) extract of hops using either disodium or dipotassium carbonate and the carbonate solution boiled to effect isomerization. The weaker β -acids will not dissolve in the carbonate solutions. Alternatively, both α - and β -acids may be extracted with alkali hydroxides and the solution then saturated with CO₂ gas to lower the pH and precipitate the β -acids. Care must be taken that the α -acids are not boiled with alkali hydroxides as hydrolysis to humulinic acids will occur. The iso- α -acid solution is best injected into a beer main because addition to conditioning tanks may cause local supersaturation and precipitation of the iso- α -acids which will only slowly redissolve. The calcium and magnesium salts of the α -acids can be isomerized by heating at 70 °C for two hours. The iso- α -acid salts formed are finely ground (particles < 10 μ m) and added to conditioning tanks when at least 24 hours are necessary to achieve solution and 85% utilization. The β -acids recovered from the above processes may be added to the copper with or without deliberate oxidation. The official methods of analysis give two HPLC methods to determine the iso- α -acids in isomerized hop extracts. Both allow for the separation of isocohumulone, isohumulone and isoadhumulone; one uses 4-methylbenzophenone as internal standard, the other β -phenylchalcone. The gross structure of the iso- α -acids has been confirmed by synthesis (Ashurst and Laws, 1966, 1967) but the low yield means that this is not a practical route to synthetic iso- α -acids.

The structures assigned to isohumulone (8.40) and humulinic acid (8.3) both contain two chiral centres so each should exist as two pairs of enantiomers. However, since natural (*R*)(–)-humulone is a single enantiomer only two diastereoisomeric forms are found, the *cis*- and *trans*-isomers (see definitions above). The enantiomers of these compounds would be obtained from unnatural (*S*)(+)-humulone. Countercurrent

distribution of the bittering substances in beer showed three peaks corresponding to isocohumulone, isohumulone and isoadhumulone but each peak was broader than that calculated for a pure compound and two theoretical curves could be fitted under each observed peak. The same broadened pattern was exhibited by isohumulone obtained by boiling humulone in *N*/15 sodium hydroxide for three minutes, 0.1 *N*-disodium carbonate for 30 min. or in a pH 5.0 buffer solution. The proton magnetic resonance spectra of these isohumulone preparations were in agreement with them being a mixture of two stereoisomers (Burton *et al.*, 1964). Eventually the two stereoisomers of isohumulone were separated by reversed-phase partition chromatography (Spetsig, 1964), counter-current distribution after 2000 transfers (Alderweireldt *et al.*, 1965), partition chromatography on silica gel (Clarke and Hildebrand, 1965) and, later, thin layer chromatography (Aitken *et al.*, 1970) and shown to be the *cis*- (8.43) and *trans*- (8.44) -isomers as expected. At the same time it was found that irradiation of humulone at either 365 or 254 nm gave pure crystalline *trans*-isohumulone (8.44 photoisohumulone) (Clarke and Hildebrand, 1965 (see also Sharpe and Ormrod, 1991)), so this isomer is more readily available pure than the oily *cis*-isomer.

Chemically, the isomerization of humulone is a type of benzilic acid or acyloin rearrangement and the mechanism is given in Fig. 8.8. The isomerization follows first-order kinetics in buffer solutions of constant pH but falls off in wort probably due to the lowering of the pH. The two isomers of isohumulone are not readily converted into each other but, since the isomerization of humulone is reversible, they can be interconverted via humulone. When isohumulone is heated alone, in wort, in a buffer solution pH 4.5, or in 0.1 *N*-disodium carbonate, 10–15% of humulone is formed. The same percentage of humulone is found when isohumulone is shaken in a two phase system of iso-octane and a pH 5.0 buffer solution so it follows that pure isohumulone cannot be isolated by countercurrent distribution. Koller (1969) found that the isomerization of the α -acids was catalysed by divalent ions, especially calcium and magnesium, and that the iso- α -acids prepared in this way were free of humulinic acids. As mentioned above, the calcium and magnesium salts of the iso- α -acids can be used as bittering agents and they are formed in the preparation of isomerized pellets (Chapter 7).

The separation and analysis of the six iso- α -acids, as in isomerized extracts and beer, remains difficult; HPLC is the method of choice. Thornton *et al.* (1993) found that the *trans*-iso- α -acids in ethyl acetate formed insoluble salts with dicyclohexylamine leaving the *cis*-isomers in solution. Thus a mixture of six iso- α -acids is converted into two mixtures of three which are easier to resolve by HPLC (Hughes, 1996). Using these techniques Hughes *et al.* (1997) were able to show that the amount of *cis*- and *trans*-iso- α -acids formed depends on the reaction conditions employed (Table 8.2) and that the *cis*- and *trans*-isomers behave differently. During wort boiling with different hop products (Type 90 pellets from Wye Target and a liquid CO₂ extract from Galena) the proportion of isocohumulone present is at a maximum after 30 min.; the utilization of humulone and adhumulone is slower. This may be due to the fact that in wort cohumulone (pK_a 4.7) is more ionized than humulone (pK_a 5.5).

The *cis/trans*-ratio of the iso- α -acids (68:32) appears to be constant during wort boiling and it is generally thought that this ratio represents the thermodynamic equilibrium, i.e., the *cis*-isomers are energetically more likely to be formed during wort boiling. During fermentation the iso- α -acids are lost by adsorption on to the yeast head. The less polar iso- α -acids, isohumulone and isoadhumulone, interact more strongly with the yeast cells causing an enrichment of isocohumulone in the beer. Earlier workers had found that cohumulone was utilized into beer better than the other α -acids but the above work

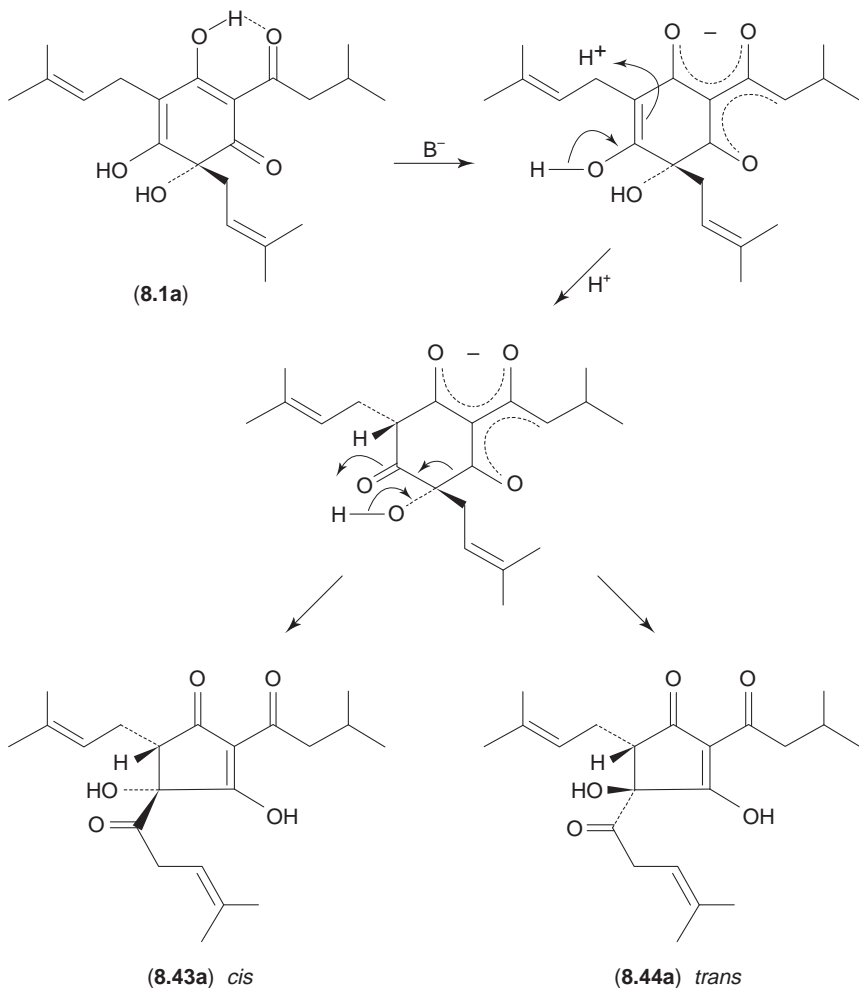

Fig. 8.8 Mechanism for the isomerization of humulone (De Keukeleire and Verzele, 1971). Copyright (1971) with permission from Elsevier.

Table 8.2 Typical ratios of *cis/trans*-iso- α -acids under a range of isomerization conditions (Hughes *et al.*, 1997)

Means of isomerization	<i>cis</i> -isomers (%)	<i>trans</i> -isomers (%)	Reference
Magnesium oxide	80	20	Hughes (unpublished)
Wort boiling	68	32	Verzele and De Keukeleire (1991)
Aqueous alkali	55	45	Koller (1969)
Light	0	100	Clarke and Hildebrand (1965)

suggests that this is due to the preferential removal of the other iso- α -acids. The importance of the proportion of isocohumulone in the beer iso- α -acids on the flavour of beer is still a subject for debate. Rigby (1972) said that isocohumulone had a harsh bitter flavour and, in the days of boiling hops in wort, brewers preferred hops with a low proportion of cohumulone in their α -acids. This harsh flavour has not been commented upon by later

workers. Of the four major iso- α -acids found in beer *cis*-isohumulone was found to be the most bitter. (c. 1.82 times more bitter than *trans*-isohumulone), *trans*-isocohumulone was the least bitter (c. 0.74 that of *trans*-isohumulone) and there was little difference in bitterness between *cis*-isocohumulone and *trans*-isohumulone (Hughes and Simpson, 1996). Hughes (2000) has reviewed the significance of the iso- α -acids for beer quality.

It is well known that beer deteriorates on storage, slowly at 0°C and in cool cellars, but more rapidly in centrally heated houses and supermarkets. Forced ageing at 37° or 40°C is used to forecast beer stability. During the storage of beer there is a loss of iso- α -acids probably due to autoxidation and free radical reactions accelerated by iron ions and hydrogen peroxide (Kaneda *et al.*, 1992). It follows that the level of antioxidants in the beer will moderate the rate of deterioration. However, De Cooman *et al.* (2000) found that both in lagers and top-fermented beers the *trans*-iso- α -acids deteriorated at a much faster rate than the *cis*-isomers. During the first 15 months of storage the loss of iso- α -acids was mainly due to decomposition of the *trans*-isomers. In the *trans*-iso- α -acids the double bonds in the 3-methyl-2-butenyl- and 4-methyl-3-pentenoyl-side chains lie close together and it is suggested that this increases their susceptibility to autoxidation. As mentioned earlier, the α - and β -acids also undergo autoxidation. The β -acids, with geminal-isoprenyl groups, are too sensitive to autoxidation to be separated by countercurrent distribution. The unsaturated side-chains of the hop resins are undoubtedly the site of attack at the carbon next to the double bond and the hydroperoxides formed could break down to isobutyraldehyde (8.14) and acetone (Fig.

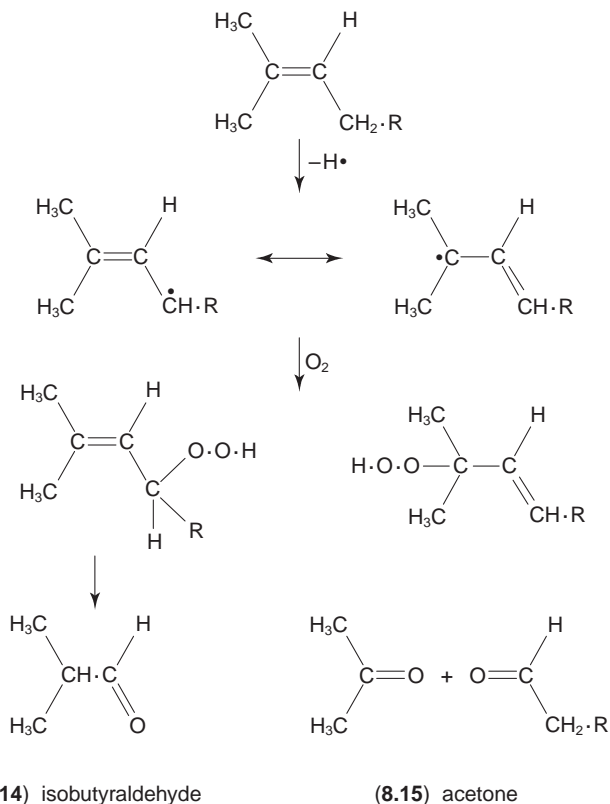

Fig. 8.9 Proposed autoxidation of 3-Methylbut-2-enyl side chains.

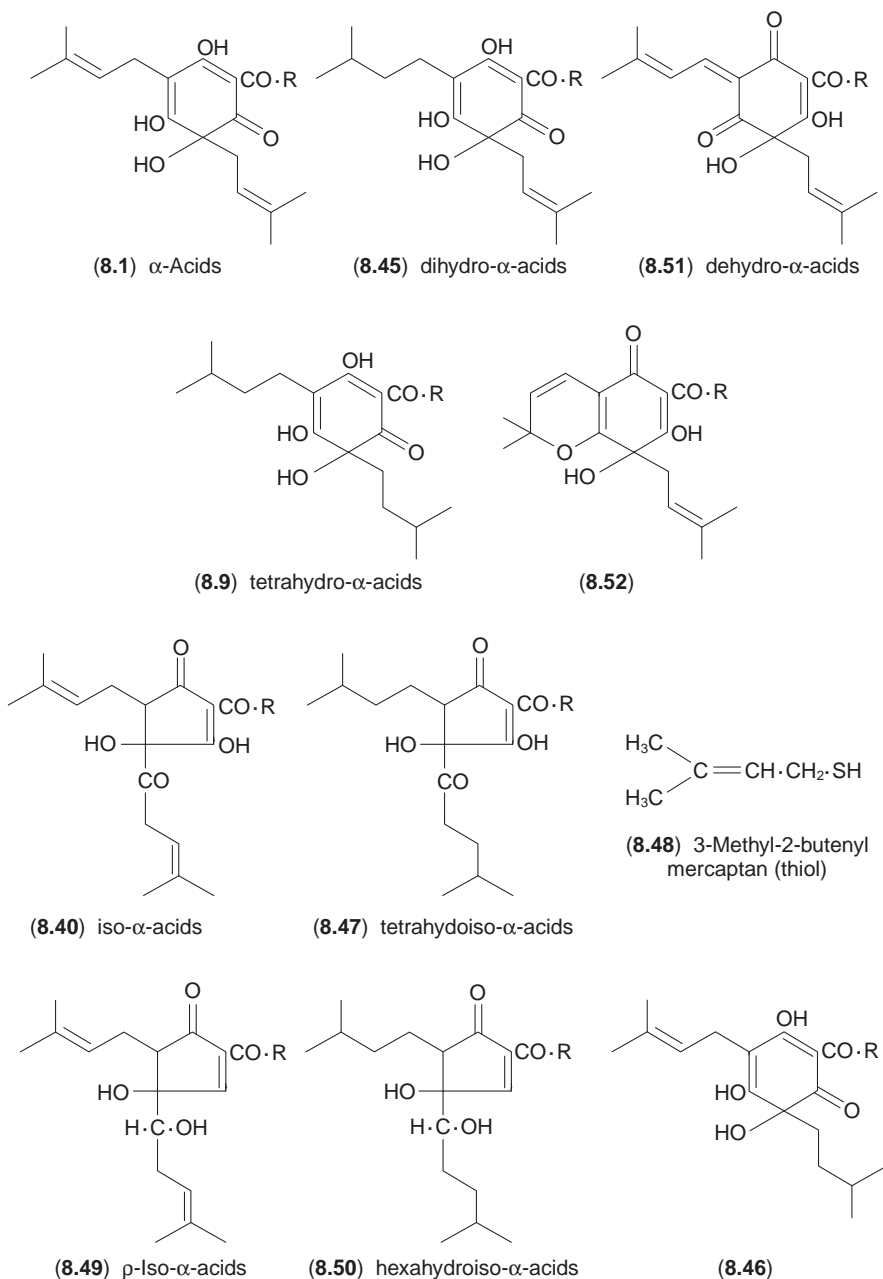

Fig. 8.10 Reduced iso- α -acids.

8.9). This route to isobutyraldehyde is probably more important than the second pathway shown in Fig. 8.7.

Obviously if these unsaturated side-chains are reduced (Fig. 8.10), the saturated products will be much less sensitive to autoxidation. Hydrogenation of humulone (8.1a) in the presence of platinum (IV) oxide give first the dihydrohumulone (8.45a) and then tetrahydrohumulone (8.9a). The alternative dihydrohumulone (8.46a) does not appear to

be formed. As mentioned, hydrogenation of humulone in the presence of palladium chloride leads to hydrogenolysis loss of an isoprenyl side-chain (Fig. 8.1). Similarly hydrogenolysis of the β -acids (**8.2**) gives tetrahydrodeoxy- α -acids (**8.8**) which can be oxidized to tetrahydro- α -acids (**8.9**). The tetrahydro- α -acids were resolved by counter-current distribution and these reactions were used to determine the analogues present in the β -acids when it was found that the β -acids are always richer in the co-component than the α -acids. So tetrahydro- α -acids, obtained from the β -acids will always be richer in cohumulone than those obtained by hydrogenation of the α -acids. In addition, tetrahydro- α -acids obtained by hydrogenation of α -acids will be optically active, while those from β -acids will be racemic.

Both the dihydro- α -acids and the tetrahydro- α -acids can be isomerized to the corresponding iso- α -acids. In particular, tetrahydroiso- α -acids (**8.47**) are light stable, more bitter than the unsaturated iso- α -acids and more potent foam stabilizers (Baker, 1990). The tetrahydroiso- α -acids are approved by the FDA for use as bittering agents and many brewers use them, with or without iso- α -acids, for post-fermentation bittering. The tetrahydroiso- α -acids can be prepared from α -acids either by hydrogenation followed by isomerization or by isomerization followed by reduction. The latter route is preferred and the two stages can be combined to give an efficient one-step preparation (Hay and Homiski, 1991). Numerous patents also describe the preparation of tetrahydroiso- α -acids. Analysis of beer bittered with a mixture of iso- α -acids and tetrahydroiso- α -acids showed the expected 12 peaks on the HPLC chromatogram. After 12 months storage at 25 °C, only the *trans*-iso- α -acids had deteriorated significantly; the tetrahydroiso- α -acids were stable (De Cooman *et al.*, 2000). It is noteworthy that these workers developed a HPLC system to resolve the 12 peaks.

Before the use of tetrahydroiso- α -acids (**8.47**) as bittering agents it was found that beer stored in clear glass bottles and exposed to sunlight developed an unpleasant skunky, sunstruck flavour found to be due to 3-methyl-2-butenyl mercaptan (thiol) (**8.48**). It was envisaged that photolysis of the iso- α -acids either produced a 3-methyl-2-butenyl- radical directly or produced a 4-methyl-3-pentenoyl- radical which decarbonylated to the 3-methyl-2-butenyl- radical. This radical then scavenges a thiol group from any available sulphur amino acid or protein (see also Heyerick *et al.*, 2003). It was found that reduction of the iso- α -acids with sodium borohydride produced a bittering agent insensitive to light, the so-called rho- (ρ) -iso- α -acids (**8.49**). Borohydride reduction attacks the carbonyl group of the 4-methyl-3-pentenoyl side chain of the iso- α -acids forming a secondary alcohol and a new chiral centre. Each iso- α -acid will form two ρ -iso- α -acids and all four isomers of ρ -isohumulone have been separated and characterized. They are less bitter than normal isohumulone but no significant difference was noticed between the bitterness of the individual isomers. Sodium borohydride reduction of tetrahydroiso- α -acids (**8.47**) produces hexahydroiso- α -acids (**8.50**). Again each stereoisomer of the tetrahydroisohumulone will produce two isomeric hexahydrohumulones. The hexahydroiso- α -acids are light stable, more bitter than conventional iso- α -acids but less bitter than the tetrahydroiso- α -acids and lead to an unnaturally dense foam. The properties of these semi-synthetic bittering agents are compared in Table 8.3. The dicyclohexylamine salts of the iso- α -acids, the ρ -iso- α -acids, and the hexahydroiso- α -acids have been prepared as standards for HPLC analysis (Maye *et al.*, 1999); the tetrahydroiso- α -acids may be used directly after recrystallization.

The dihydrohumulone (**8.45a**) has been found in hop extracts, especially those containing the water-soluble fraction (Moir and Smith, 1995). The level decreases during storage and the formation is catalysed by the monovalent sodium and potassium ions. It

Table 8.3 Semi-synthetic bittering agents (Marriott, 1999)

Product	Relative bitterness	Relative foam enhancement at equivalent bitterness	Light stable
Iso- α -acids	1.0	x	No
Rho (ρ)-iso- α -acids	0.65	xx	Yes
Tetrahydroiso- α -acids	1.7	xxx	Yes
Hexahydroiso- α -acids	1.1	xxxx*	Yes

* Foam unnaturally dense

was found that at low temperatures, e.g., 3 °C, a disproportionation reaction occurs: two molecules of humulone give one molecule of dihydrohumulone (**8.45a**) and one molecule of dehydrohumulone (**8.51a**). At higher temperatures, e.g., 35 °C, the isomerization of the α -acids predominates. Dehydrohumulone (**8.48**) is a very reactive compound which may either cyclize to a pyran (**8.52**) or polymerize.

8.2.5 Hard resins and prenylflavonoids

By definition the hard resin is soluble in methanol and diethyl ether but insoluble in hexane. As hops age during storage the level of soft resins falls and that of the hard resins increases. Thus we must distinguish between 'native' hard resins, present in fresh hops, and those formed by oxidation during storage. Many of the native hard resins are made up of prenylflavonoids which are deposited with the soft resins and essential oils in the lupulin glands. Hop flavonoids have been reviewed by Stevens *et al.* (1998) including, as well as the prenylflavonoids, flavonoid glycosides, condensed tannins and other polyphenols which are largely soluble in water. The biosynthesis of the flavonoids (Fig. 8.11) is similar to that of the hop resins. The aromatic amino acids phenylalanine and tyrosine (**8.53**) lose ammonia to give, for example, *p*-coumaric acid (**8.54**), the Coenzyme A ester of which condenses with three molecules of malonyl Coenzyme A to form a chalcone (**8.55**, chalconaringenin) which can cyclize to a flavanone (**8.56**, naringenin). Dehydrogenation of flavanones can give flavones while dehydrogenation and hydroxylation leads to flavanols, e.g., kaempferol (**8.57**) and quercetin (**8.58**).

The major component of the prenylflavonoids in hops (Fig. 8.12) is the chalcone xanthohumol, first isolated in 1913 although the structure, 6'-*O*-methyl-3'-prenylchalconaringenin (**8.59**), was not worked out until the 1960s. It is accompanied by smaller amounts of the related flavanone isoxanthohumol (**8.65**, humulol, 5-*O*-methyl-8-prenylnaringenin). This is racemic and it is thought that the lupulin glands lack the enzyme chalcone isomerase which converts chalcones to flavanones. Accordingly, all the racemic naringenin derivatives isolated from hops and beer are thought to be artefacts. Optically active isoxanthohumol has been isolated from *Sophora angustifolia*. Hops contain 0.1–0.8% of xanthohumol, the level falling on storage. Part of a growth of Eastwell Golding hops was freeze dried when the level of xanthohumol was 0.86%. When the same hops were kilned, with or without sulphur, the level fell to 0.31%. The level of isoxanthohumol appeared to be the same in all three samples. Stevens *et al.* (1997) found 8 prenylflavonoids and 3'-geranylnaringenin (**8.61**) in hops. Xanthohumol accounted for 82–89% of this fraction, desmethylxanthohumol (**8.60**) 2–3%, dehydrocycloxanthohumol (**8.63**) 2–4%, and dehydrocycloxanthohumol hydrate (**8.64**) 3–5%. The level of isoxanthohumol (**8.65**) was only 1–2% but during the brewing process nearly all of the chalcones are cyclized to flavanones. Xanthohumol can only cyclize to

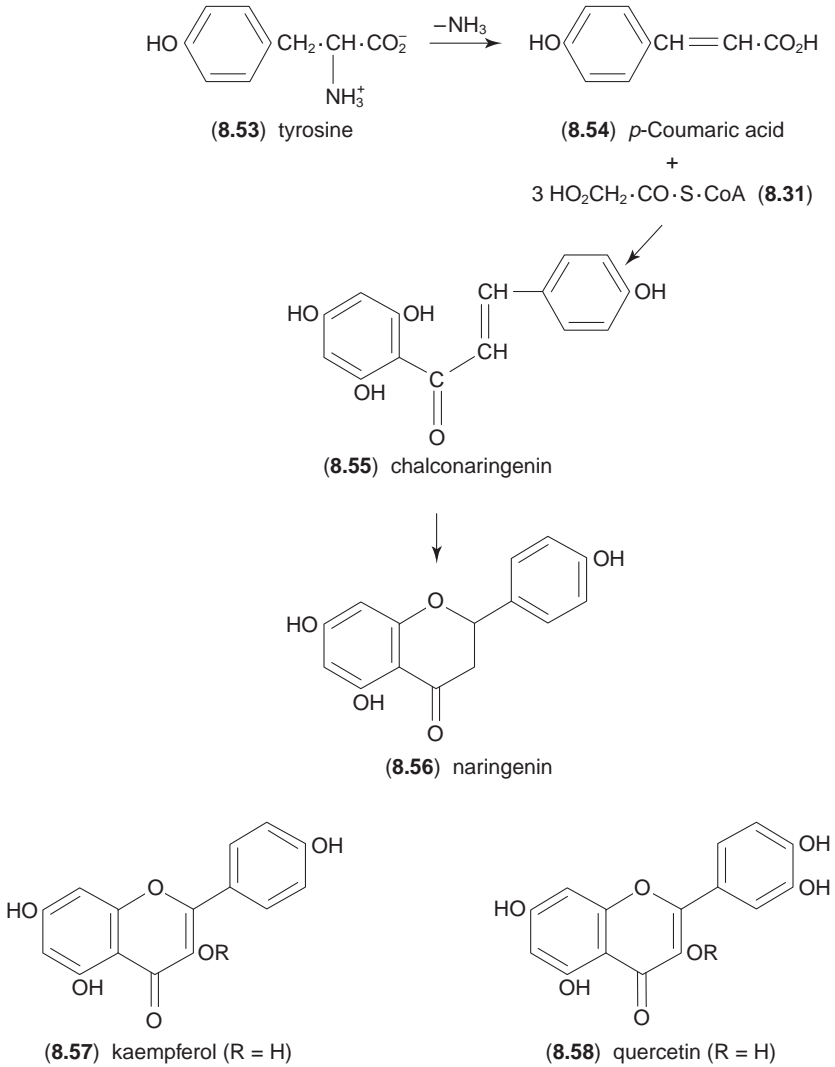
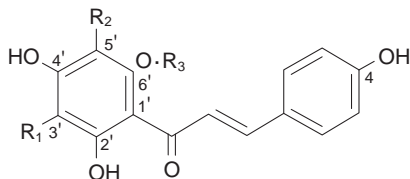

Fig. 8.11 Biosynthesis of flavonoids.

isoxanthohumol but desmethylxanthohumol (**8.60**) gives a mixture of 6- (**8.66**) and 8-prenylnaringenin (**8.67**). Similarly, 3'-geranylchalconaringenin (**8.61**) can give two products. 6-Geranylnaringenin (**8.68**) has been found in beer but not in hops so it is presumably formed from (**8.61**) during the brewing process.

During the brewing process 69% of the available xanthohumol was in solution after the whirlpool and 13% was recovered from the spent hops. However, further losses on to the trub and the yeast mean that only about 30% of the available xanthohumol ends up in the beer (as isoxanthohumol). Thus the level of xanthohumol in 11 beers was 0.002–0.69 mg/l while that of isoxanthohumol was 0.04–3.44 mg/l. Similarly, only 11% of the available desmethylxanthohumol was found in beer as a mixture of 6- and 8-prenylnaringenin (Stevens *et al.*, 1999). The prenylflavonoids show interesting biological activities *in vitro* including antiproliferative effects on cancer cells, anti-carcinogenic



R ₁	R ₂	R ₃	
Prenyl	H	Me	xanthohumol (8.59)
Prenyl	H	H	desmethylxanthohumol (8.60)
Geranyl	H	H	3'-Geranylchalconaringenin (8.61)
Prenyl	Prenyl	Me	5'-Prenylxanthohumol (8.62)

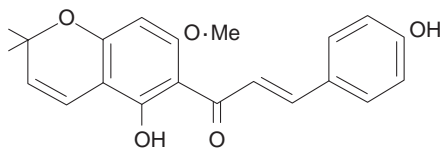

(8.63) dehydrocycloxanthohumol

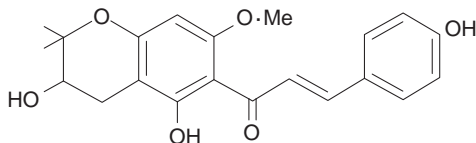

(8.64) dehydrocycloxanthohumol hydrate

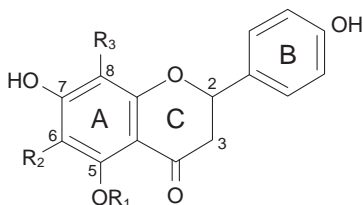

R ₁	R ₂	R ₃	
Me	H	Prenyl	isoxanthohumol (8.65)
H	Prenyl	H	6-Prenylnaringenin (8.66)
H	H	Prenyl	8-Prenylnaringenin (8.67)
H	Geranyl	H	6-Geranylnaringenin (8.68)

Fig. 8.12 Prenylflavonoids in hops.

effects, effects on lipid metabolism, oestrogenic and antimicrobial activity (Stevens, *et al.*, 1998). Whether the concentrations in beer are sufficient to influence the consumer is yet to be determined. For example, the highest concentration of 8-prenylnaringenin, reported to be a phytoestrogen, found in beer was 19.8 μM /litre.

8.2.6 Oxidation of hop resins

As mentioned above hops deteriorate on storage, largely by oxidation; the soft resins decrease, the hard resins increase. The rate of deterioration can be followed by the Hop Storage Index (HSI) (p. 269). Nikerson and Likens (1979) found the regression equation

$$\%(\alpha + \beta) \text{ lost} = 110 \log (\text{HSI}/0.25)$$

and that there was a linear relationship between the $\%(\alpha + \beta)$ lost, determined from the HSI, and the formation of hard resin. The rate of deterioration depends very much on the variety which appears to determine the length of the lag phase before deterioration starts. Thereafter the loss of both α - and β -acids can be fitted to either zero or first order kinetic equations (Green, 1978). To minimize such deterioration brewers used to keep their hops in cold store (0.20 °C) which was expensive for such a bulky crop. Whitear (1965, 1966) questioned the need for this with copper hops since he found the bittering value of aged hops did not decline as rapidly as the analyses indicated (Fig. 8.13). However, on a commercial scale hops lost as much as 15–20% of the brewing value of the original α -acids over two years at ambient temperature. From these and other trials, it was suggested that the level of α -acids at harvest was the best guide to the amount of hops to be used in the copper. Accordingly, the bulk of the English hop crop was analysed within a month of harvest (see *J. Inst. Brewing*, 1969–1988). The production of hop pellets greatly reduced the volume of the crop and the saving in cold storage space helped to offset the cost of pelletization. Further, the pellets could be stored in an inert atmosphere more easily than bales or pockets.

Old hops develop a cheesy aroma due to isovaleric, isobutyric and 2-methylbutyric acids produced by oxidative cleavage of the acyl side chains of the resins. Fresh hops contain 1–3% of volatile acids; after three years storage this increased to 20%. As mentioned earlier photolysis of colupulone (8.2b) causes loss of a 3-methyl-2-butenyl (isoprenyl) side chain to give deoxycohumulone (8.26b). Similarly, mild acid hydrolysis, wort boiling or atmospheric degradation of the β -acids causes loss of isoprenyl side chains giving eventually the phloracylphenone (8.22). The isoprenyl side chains so displaced form mainly 2-methyl-3-buten-2-ol (8.69) which is absent from green hops but found after kilning and increases in stored hops. It is thought to be responsible for the soporific effects of hops and their use in hop pillows. Other volatile compounds which develop during hop storage include 2-methyl-2-butene, isoprene (8.23), 3-methyl-2-

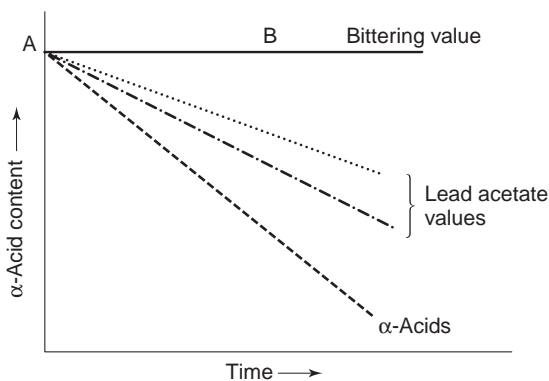

Fig. 8.13 Schematic diagram of the changes in resin content and bittering value of hops during storage (Whitear, 1965, 1966).

buten-1-ol, 5,5-dimethyl-(5*H*)-2-furanone (**8.70**), acetone, methyl isopropyl ketone, and methyl isobutyl ketone. The last two compounds are thought to be relics of the acyl side chains.

As mentioned above, isoprenyl side chains are very sensitive to autoxidation but the ring system can also be attacked and such reactions can be studied in saturated compounds produced by hydrogenation. Many compounds have been characterized by deliberate oxidation of individual hop resins (Fig. 8.14) but it is often difficult to find these oxidation products in stored hops or beers brewed therefrom. For example, oxidation of humulone (**8.1a**) with organic peroxides in the presence of base gives *trans*-humulinone (**8.71**), pKa 2.8, which is intensely bitter, but, over 50 years, its presence in stored hops has not been established unequivocally. In contrast, oxidation of humulone with lead tetra-acetate gives tricyclodehydroisohumulone (**8.72**, TCD), which has been found in stored hops, in amounts up to 0.3%, and in beer (4 ppm). The bitterness of TCD is reported to be 70% that of *trans*-isohumulone (**8.44**) and it may contribute as much as 5% of the total bitterness of beer. Oxidation of humulone with monoperphthalic acid gives (**8.73**) which may account for 1–5% of the hard resin. This compound (**8.73**) may be an intermediate in the formation of (**8.74**) obtained by the autoxidation of humulone in hexane. (**8.74**) has a bitter taste and is more water soluble than most hop resins but the bitterness is lost on boiling. Oxidation of humulone with *m*-chloroperbenzoic acid gives (**8.75**) but the bitterness and importance of this compound is not reported. Boiling humulone in aqueous buffer solutions gives, in addition to isohumulone, a complex mixture of products from which (**8.76**) has been isolated. Later, (**8.76a**) and (**8.76b**) were detected in beer but only in trace amounts. When oxygen is bubbled through a boiling solution of humulone containing Celite a series of *abeo*-isohumulones (**8.77–8.83** Fig. 8.15) are formed. They are reported to be present in hops and beer; they are only slightly bitter but display strong foam-stabilizing activity.

Probably the most important oxidation products of the β -acids (**8.2**) (Fig. 8.16) are the hulupones (**8.85**) obtained by autoxidation. The hydroperoxide (**8.84**) has been proposed as an intermediate but has not been isolated. However, the saturated hydroperoxide, derived from (**8.84**), has been isolated from the autoxidation of hexahydrocolupulone. The hulupones (**8.85**) are reported to be twice as bitter as the iso- α -acids; they are not found in green hops but accumulate during storage when concentrations of 3% have been reported. However, they are formed when hops are macerated in air in a blender so the analytical results are probably high. They are also formed in wort boiling and survive into beer (several ppm). They may be more important in stout brewing when hops are boiled with wort more than once. After the first boil, the resins that have not dissolved will be spread over the surface of the spent hops making them accessible to autoxidation between boils. Probably most claims for better utilization of the β -fraction involve oxidation of the β -acids into hulupones. In the laboratory, oxygenation of the β -acids in the presence of sodium sulphite or oxidation with sodium dioxypersulphate, gives better yields of hulupones. Hulupone (**8.85a**), pKa 2.6, has been synthesized by the akylation of dehydrohumulinic acid (**8.10a**) with 3-methyl-2-butenyl bromide (**8.24**). With regard to bitterness of hulupones, Verzele and De Keukeleire (1991, p.377) report that beers bittered only with pure hulupone (100 mg/l) were undrinkable but beers with 100 IBU derived from iso- α -acids are also likely to be unacceptable.

Autoxidation of hulupones in boiling ethanol gives hulupinic acid (**8.86**) which lacks bitterness but has been found in the hard resin of old hops (0.05%). Apart from the hulupones, autoxidation of the β -acids gives complex mixtures of products. Verzele and De Keukeleire (1991) devote 86 pages to oxidation products of the β -acids and describe

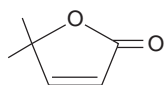
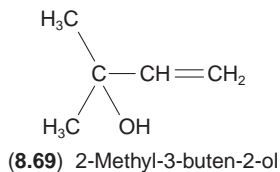

(8.70) 5,5-Dimethyl-(5H)-furan-2-one

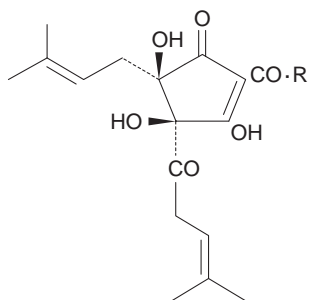
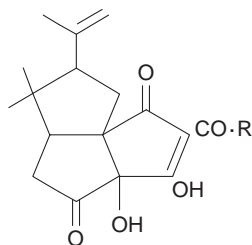
(8.71) *trans*-Humulinone

(8.72) tricyclodehydroisohumulone (TCD)

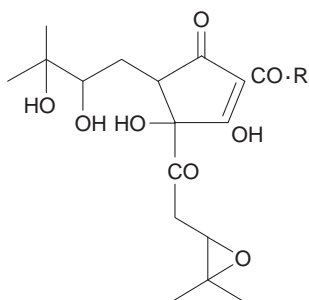

(8.73)

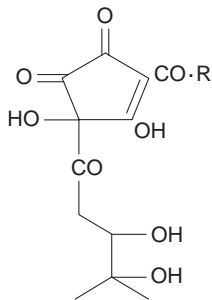

(8.74)

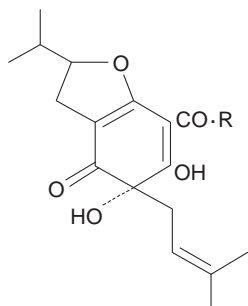

(8.75)

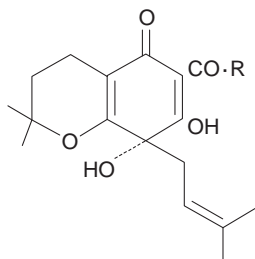

(8.76)

Fig. 8.14 Oxidation products of the α -acids.

over 40 products. Probably most of these occur in trace amounts in old hops and beers brewed therefrom but their importance has yet to be determined.

Although used today principally for their bittering properties, hops were originally used for their preservative value. Simpson (1993b) has studied the effects of the hop bitter acids on lactic acid bacteria. He found that the hop bitter acids act as mobile carrier

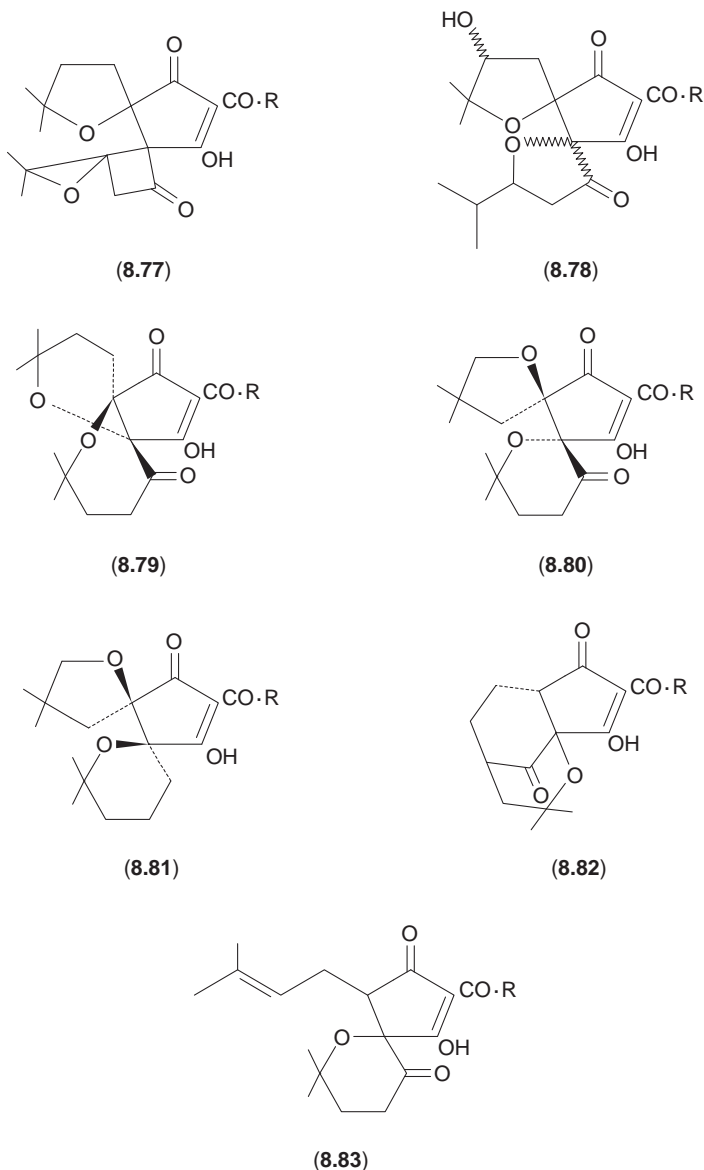

Fig. 8.15 Abeo-iso- α -acids (Verzele and De Keukeleire, 1991).

ionophores and inhibit the growth of beer spoilage organisms by dissipating the transmembrane pH gradient.

8.3 Hop oil

8.3.1 Introduction

Hops produce up to 3% of essential oil which is responsible for the pleasant hoppy aroma of beer. It is produced in the lupulin glands along with the resins, mostly after resin synthesis is finished. It is largely from the aroma that the grower judges that the

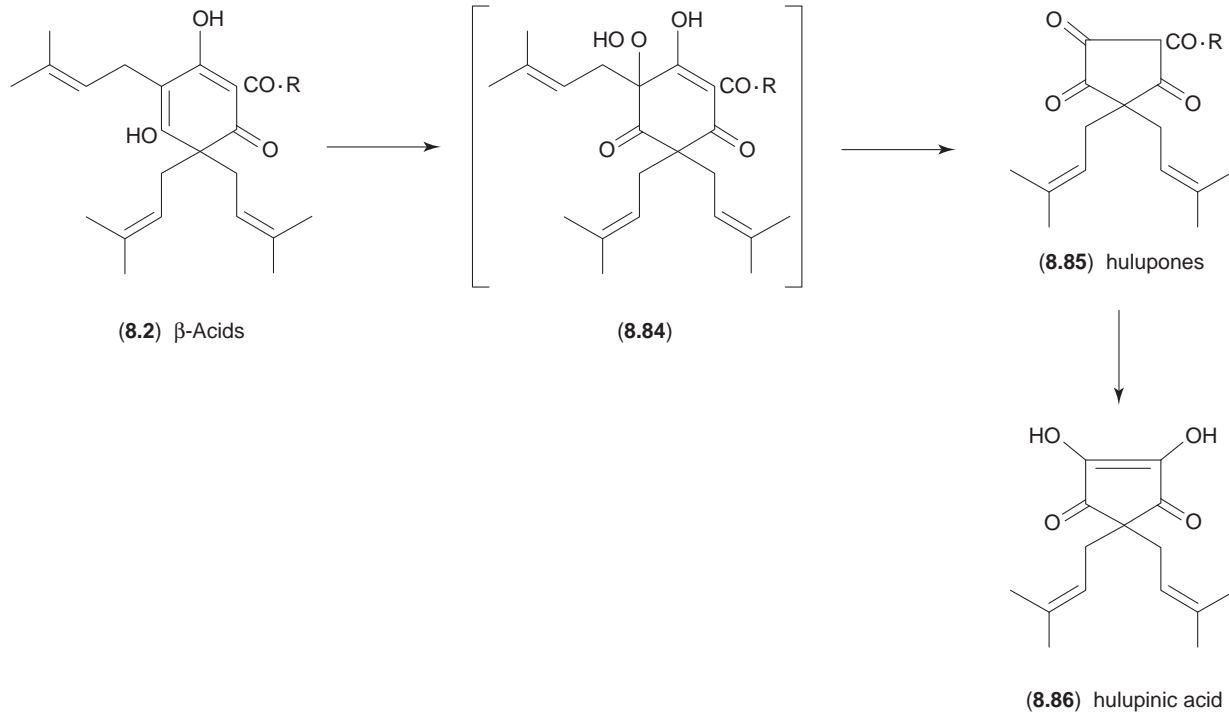

Fig. 8.16 Oxidation products of the β -acids.

hop is ripe and ready to pick. The composition of the essential oil depends on genetic (cultivar) and cultural factors but since most commercial hops are picked at an equivalent degree of ripeness varietal factors will dominate. Nevertheless, in any one variety, seedless hops will produce more essential oil than seeded hops. For reviews on hop oil see Sharpe and Laws (1981), Stevens (1987), Moir (1994), Deinzer and Yang (1994) and Siebert (1994).

By definition, essential oils are volatile in steam, so most essential oil will be lost when hops are boiled in wort in a copper open to the atmosphere. To add hop aroma to their beers brewers either add a portion of choice hops towards the end of the boil (most lager brewers) or add dry hops to the beer either in cask or conditioning tank (premium ales). The hops used for late and dry hopping are chosen for their choice aroma, which may be transferred directly to the beer. Brewers are usually prepared to pay a premium for such choice 'aroma' hops. The level of α -acids is immaterial since the majority will not be isomerized. The amount of essential oil in a sample of hops is usually measured by steam distillation, usually with cohobation whereby the oil is retained in a trap and the denser aqueous phase returns to the boiler together with any water-soluble constituents. Commercial hop oil, prepared in this way, does not have the true aroma of the hops from which it was prepared. Essential oil constituents are soluble in most organic solvents and CO_2 so will be present in most solvent extracts of hops. The most volatile constituents may be removed with the solvent but this is less likely with CO_2 extracts. Hop oils obtained from CO_2 extracts by molecular distillation (ambient temperature and less than 0.001 mm Hg) smell more like the original hops than steam distilled oils. Such oils may contain water-soluble constituents which would be washed out of steam distilled oils obtained by cohobation. It is also known that some essential oil constituents are altered during steam distillation. Before the advent of CO_2 extracts some brewers used commercial steam-distilled oils to dry hop their beers but most people could distinguish such beers from those dry hopped normally. Today CO_2 extracts, or fractions derived therefrom, are used to impart hop aromas to beers. Brewers are interested in which constituents of the essential oil influence the flavour of beer and, further, whether the composition of the essential oil can aid the identification of hop cultivars.

The essential oil of hops is a complex mixture of well over 300 compounds, but it can be separated into two fractions by chromatography on silica gel. The fraction eluted with light petroleum consists of hydrocarbons while that subsequently eluted with diethyl ether consists of oxygen-containing compounds such as alcohols, acids, esters, and carbonyl compounds. This latter fraction may also contain traces of sulphur-containing compounds.

The contribution of the individual constituents towards the overall aroma of hop oil can be assessed by the use of the Flavour Unit (FU) defined as:

$$\text{Flavour Unit (FU)} = \frac{[\text{Concentration of the flavour compound}]}{[\text{Sensory threshold of the flavour compound}]}$$

The FU values depend on how, and in what medium, the sensory threshold was measured but if the concentration of a compound does not exceed the sensory threshold ($\text{FU} < 1$) it will not have a large influence on the overall flavour. Compounds providing 1–2 FU will be detectable by the assessor and compounds providing more than 2 FU are likely to be dominant flavours. For example, beers contain 10–60 mg/l of iso- α -acids, the sensory detection level of which is 5–6 mg/l, so the iso- α -acids will provide 2–12 FU and the bitterness will be perceived by most drinkers (Baxter and Hughes, 2001). Individual hop

oil constituents will be discussed later but, in general, the sensory detection levels of sulphur compounds are much lower than those of the corresponding oxygen compounds which, in turn, are lower than those of the hydrocarbons.

8.3.2 Hydrocarbons

The hydrocarbon fraction may account for 50–80% of the essential oil and the major components, found in most varieties, are the monoterpene myrcene (**8.89**) and the sesquiterpenes β -caryophyllene (**8.136**) and humulene (**8.111**) which were characterized by classical means. Farnesene (**8.106**), which was first isolated from Saaz (Zatec) hops, was found to be present in some cultivars but not in others. For example, it was not found in the oils of Hallertau, Goldings, Fuggle or Cluster hops. From later plant breeding studies it is thought that the presence of farnesene is a sex-linked character controlled by a single pair of genes with presence dominant to absence. Similarly, on gas chromatograms of the hydrocarbons of some varieties, several compounds are eluted after humulene. Two of these were later identified as α - (**8.108**) and β -selinene (**8.110**). The presence or absence of selinene is also controlled by a single pair of genes but with incomplete dominance. Traces of many other terpenes and sesquiterpenes have been detected in hop oil.

As the hop ripens, trace of oxygenated compounds of the essential oil appear first, then the cyclic sesquiterpenes β -caryophyllene and humulene, and finally the monoterpene myrcene is formed. The percentage of myrcene probably reflects the ripeness of the cones but the humulene/caryophyllene ratio is usually constant and a varietal characteristic (Table 7.3). The selinene/caryophyllene ratio also appears to be a varietal characteristic.

The biosynthesis of the terpenoid compounds in the essential oil uses the same building blocks as required for the isoprenyl side chains of the hop resins (Fig. 8.3). Dimethylallyl pyrophosphate (**8.34**) condenses with a molecule of isopentenyl pyrophosphate (**8.33**) to give geranyl pyrophosphate (**8.88**), the parent of the monoterpenes and the source of the side chain in the chalcone (**8.61**) and the related flavanone (**8.68**). With another molecule of isopentenyl pyrophosphate, geranyl pyrophosphate forms farnesyl pyrophosphate (**8.105**), the parent of the sesquiterpenes. Elimination of pyrophosphoric acid from geranyl pyrophosphate (**8.88**) gives the major monoterpene myrcene (**8.89**). This and other monoterpene relationships are shown in Fig. 8.17. Similarly, elimination of pyrophosphoric acid from farnesyl pyrophosphate (**8.105**) gives (β)-farnesene (**8.106**) (Fig. 8.18). Cyclization of *trans*, *trans*-farnesyl pyrophosphate can give two monocations (**8.107**) and (**8.109**); **8.107** can lose a proton to give humulene (**8.111**) while (**8.109**) can give α - (**8.108**) and β -selinene (**8.110**). Although β -caryophyllene (**8.136**) nearly always occurs with humulene, it is thought to be formed from a *trans*, *cis*-farnesyl cation. An alternative deprotonation of **8.109** can lead to germacrene B (**8.112**), germacrene D (**8.113**) and bicyclogermacrene (**8.114**). Cyclization of germacrene B can give selina-3,7(11)-diene (**8.115**) and selina-4(15),7(11)-diene (**8.116**). Germacrene D (Fig. 8.19) is readily converted into a mixture of α - (**8.117**) and γ -muurolene (**8.120**) and δ - (**8.118**) and γ -cadinene (**8.121**). All these sesquiterpenes together with copaene (**8.119**) have been identified in hop oil.

Tressl *et al.* (1993) found at least 15 tricyclic sesquiterpenes in the essential oil of the German variety Hersbrucker spät. These hydrocarbons are probably derived from bicyclogermacrene (**8.114**, Fig. 8.20) and include viridiflorene (**8.126**), alloaromadendrene (**8.127**), aromadendrene (**8.128**) and α -gurjenene (**8.129**). Traces of the diterpenes

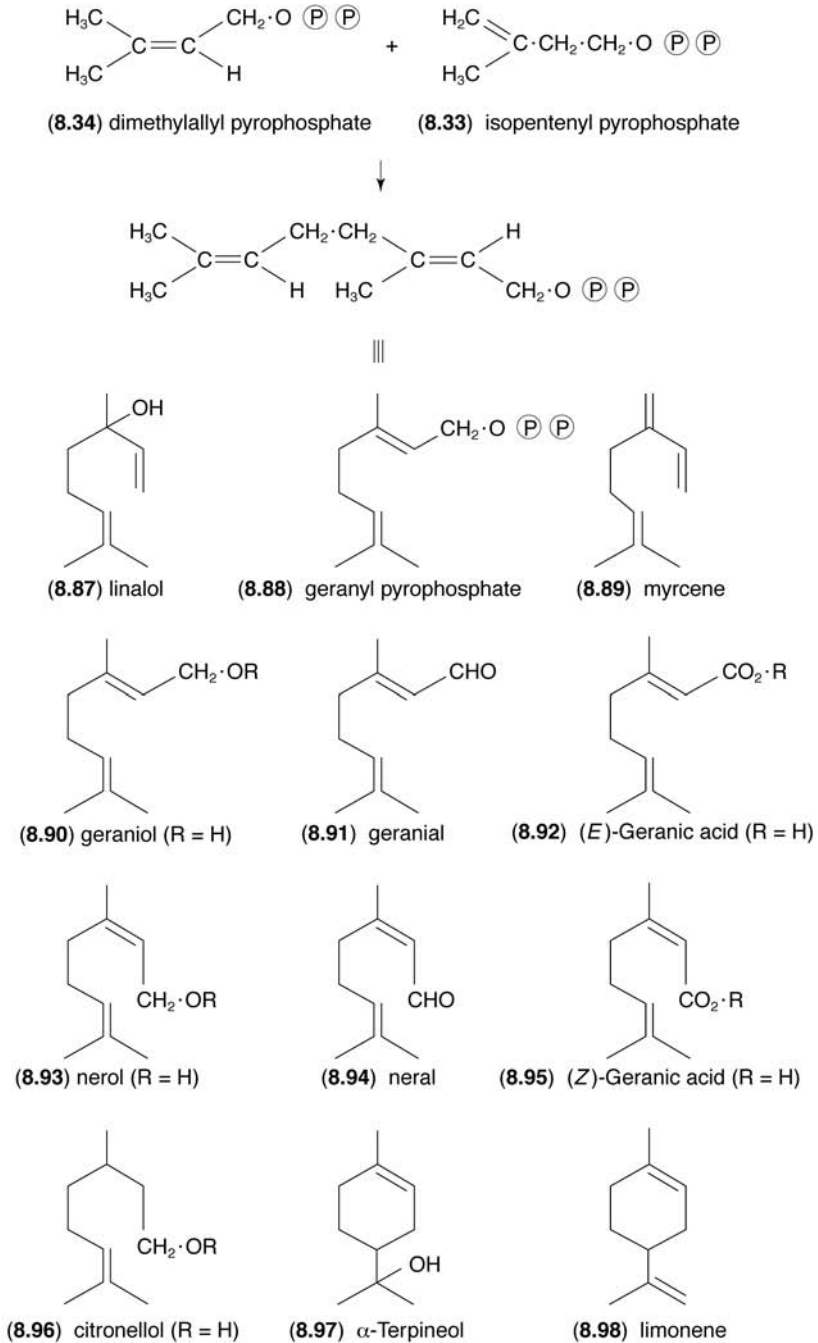

Fig. 8.17 Monoterpene relationships in hop oil.

m- and *p*-camphorene have been found in hop oil but these are thought to be artefacts formed by a Diels-Alder reaction between two molecules of myrcene. Few, if any, of these hydrocarbons survive wort boiling but traces may be found in late and dry hopped beers.

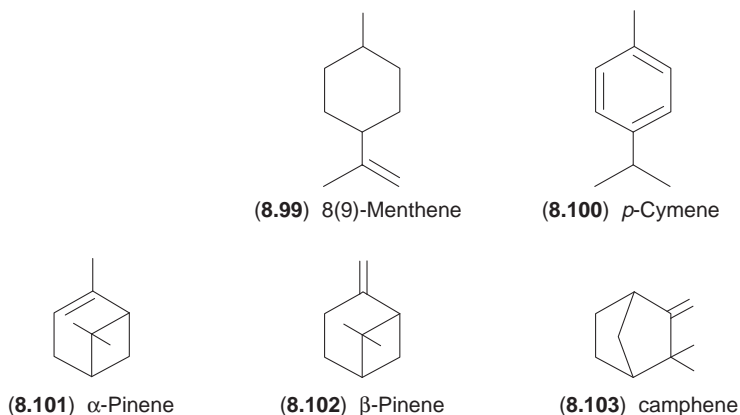

Fig. 8.17 Continued

Guadagni *et al.* (1966) found the following sensory thresholds: myrcene, 13; caryophyllene, 64; and humulene, 120 ppb. Thus, in the hydrocarbon fraction myrcene is by far the most potent odorant. In an oil from Brewers' Gold hops, myrcene (63%) accounted for 58% of the odour units. Similarly, Steinhaus and Schieberle (2000) found that myrcene was the most potent odorant in Spalter Select hops.

8.3.3 Oxygen-containing components

The oxygenated fraction of hop oil is even more complex than the hydrocarbon fraction but these polar constituents are more likely to survive into beer. Probably the first oxygenated component of hop oil to be characterized was undecan-2-one (methyl nonyl ketone, luparone), which is now known to be accompanied by other methyl ketones. Sharpe and Laws (1981) report 60 aldehydes or ketones, 70 esters, 50 alcohols, 25 acids, 30 oxygen heterocyclic compounds and 30 sulphur-containing compounds in hop oil. Among the esters both straight chain and branched chain fatty acids and alcohols are involved. For example, the methyl esters of hexanoic, octanoic, decanoic, 4-decenoic and 4,8-decadienoic acids are probably by-products of fatty acid biosynthesis. Branched chain compounds such as 2-methylbutyl isobutyrate presumably arise from pathways to the carbon skeletons of amino acids. Whether these hop esters survive into beer is difficult to determine as similar products are formed during fermentation.

During fermentation methyl 4-decenoate and methyl 4,8-decadienoate undergo transesterification to produce the corresponding ethyl esters in beer. Probably other esters behave similarly but brewing yeasts are known to produce esterases. When methyl heptanoate was added to a fermentation only 35% of the parent acid was recovered with little methyl or ethyl heptanoate. Nevertheless, transesterification of geranyl pyrophosphate (8.88) is likely to be the source of geranyl acetate, propionate and isobutyrate which give a floral note to hop oil. Mild (enzymatic) hydrolysis of these esters gives the primary alcohol geraniol (8.90, $R = H$) but under acid conditions the tertiary alcohol linalol (linalool, 8.87, Fig. 8.17) is formed. *cis,trans*-Isomerization of geraniol gives nerol (8.93, $R = H$) and neryl esters have been found in hop oil. Oxidation of geraniol and nerol gives citral, a mixture of the aldehydes geraniol (8.91) and neral (8.94) which on further oxidation give geranic acid (8.92 and 8.95), the methyl ester of which occurs in hop oil.

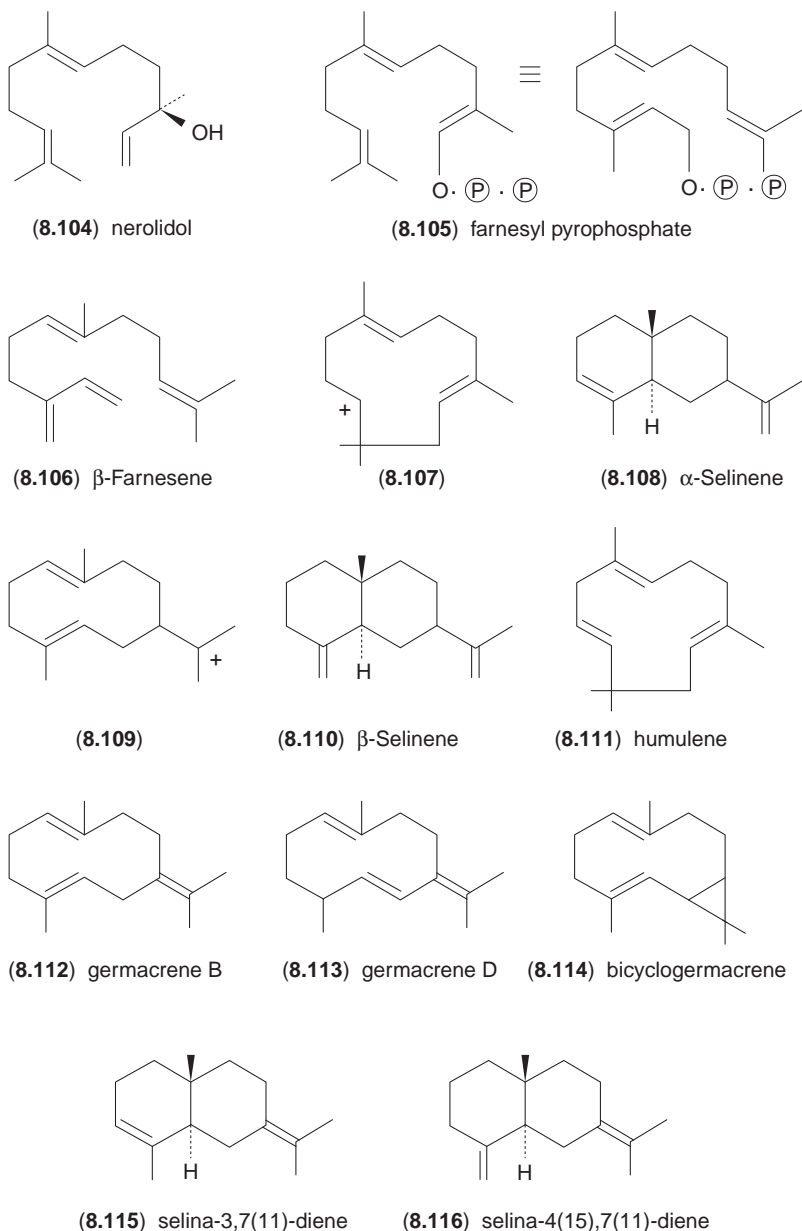

Fig. 8.18 Sesquiterpene relationships in hop oil.

Reduction of the 2,3-double bond in either geraniol or nerol gives citronellol (8.96). Nerol readily cyclizes to give α -terpineol (8.97) present in hop oil and beer. Dehydration of α -terpineol gives limonene (8.98), the major hydrocarbon of citrus oils but also present in hop oil. Limonene is probably the precursor of the bicyclic monoterpenes such as α - (9.101) and β -pinene (8.102) and camphene (8.103). Limonene can also disproportionate into *p*-cymene (8.100) and 8(9)-menthene (8.99). Similarly, mild (enzymatic) hydrolysis of farnesyl pyrophosphate (8.105) can give farnesol while acid hydrolysis gives nerolidol (8.104); both have been found in hops and beer. For these oxygenated compounds

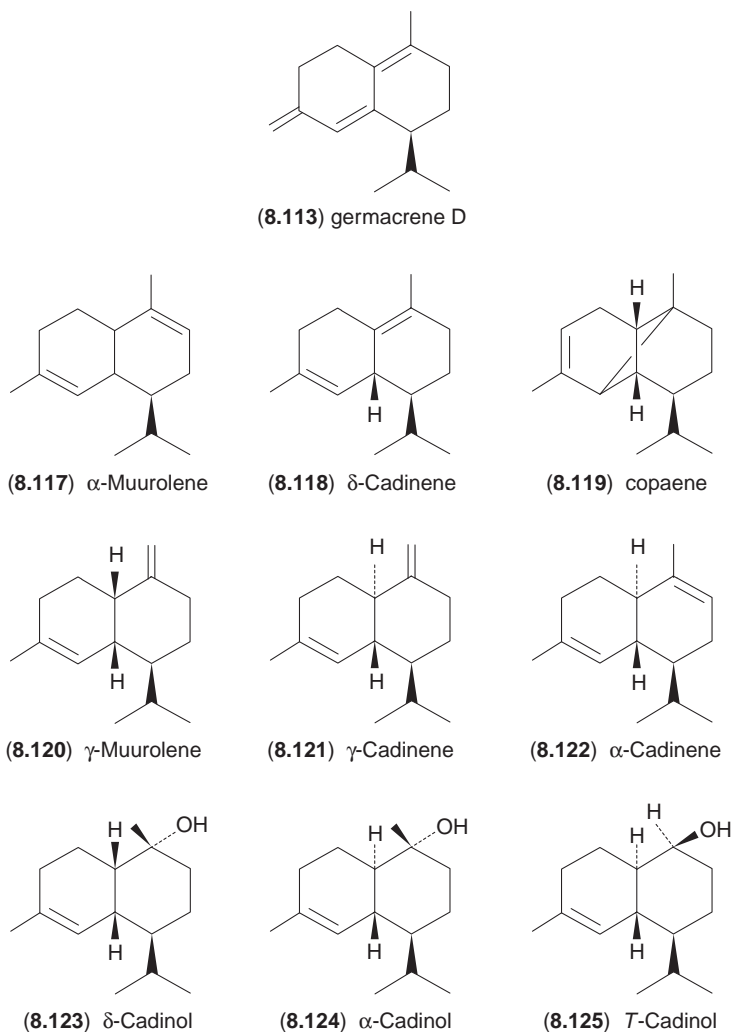

Fig. 8.19 Sesquiterpene relationships: Germacrene D and the Cadinenes.

Guadagni *et al.* (1966) found the following odour threshold values: undecan-2-one, 7; linalol, 6; methyl heptanoate, 4; methyl 4-decenoate, 3; methyl 4,8-decadienoate, 10; 2-methylbutyl isobutyrate, 14; geranyl acetate, 9; geranyl propionate, 10; and geranyl isobutyrate, 13 ppb. Thus, most of these odorants are more potent than myrcene but their concentration is usually much lower. For example, in the sample of Brewers' Gold oil mentioned above, methyl 4-decenoate contributed the largest percentage (3.0%) of the total odour units from the oxygenated fraction.

During hop storage the proportion of hydrocarbons in the essential oil decreases and that of the oxygenated components increases. The increase in volatile acids (3 → 20%) after three years storage at 0°C was mentioned earlier but these acids will be formed by oxidation of both resins and essential oil components. Carbon-carbon double bonds react with oxygen to form epoxides (oxiranes); *in vitro* peracids are the usual reagent. These three-membered rings are readily opened to give diols which may undergo further reactions. Monoterpene epoxides have not been isolated from hop oils but may be

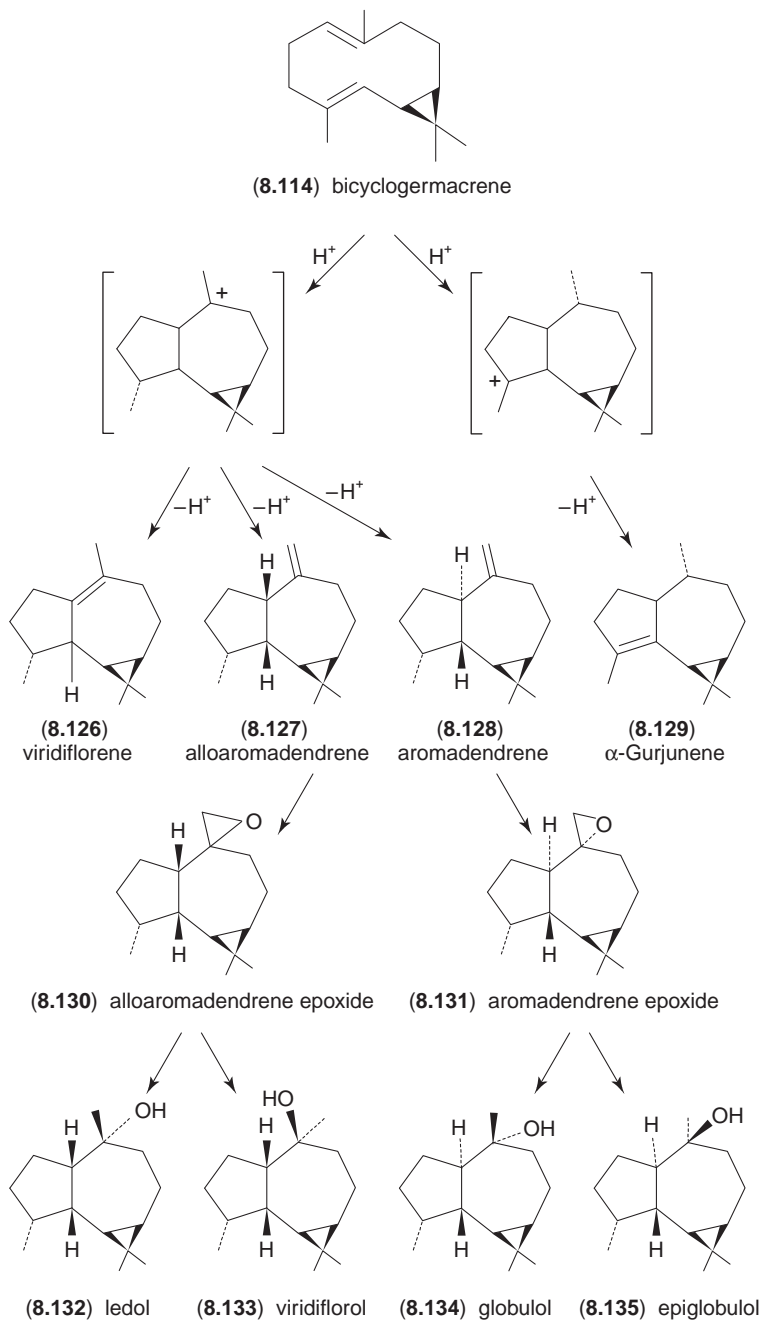

Fig. 8.20 Sesquiterpenoids from Bicyclogermacrene.

intermediates in, for example, the autoxidation of myrcene which leads to linalol, geraniol, nerol, citral (**8.91** and **8.94**) together with the cyclic limonene. In contrast, sesquiterpene epoxides are found in hop oil and their concentration increases during hop storage. β -Caryophyllene (**8.136**) (Fig. 8.21) can theoretically form two mono-epoxides but only one (**8.137**) has been found in hop oil. Some workers, but not others, have found

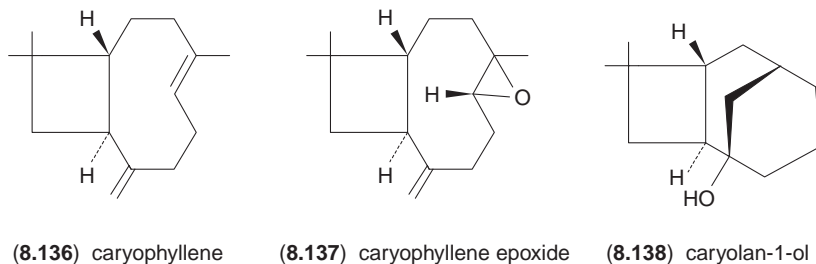

Fig. 8.21 Reactions of Caryophyllene.

it in beer. It undergoes hydrolysis to give at least six products (Deinzer and Yang, 1994). Similarly, caryolan-1-ol (**8.138**), obtained by acid treatment of caryophyllene, has been found in beer by some workers but not others.

Humulene (**8.111**) (Fig. 8.22) can form three mono-epoxides (**8.139**), (**8.140**) and (**8.141**). Of these humulene epoxide I (**8.139**) is most resistant to hydrolysis and most likely to be found in beer. Humulene epoxide II (**8.140**) and humulene epoxide III (**8.141**) can be interconverted and hydrolysis of either gives a mixture of at least 30 products; humulol (**8.146**) and humulenol II (**8.147**) predominate in beer. Although only traces of humulene diepoxides are found in fresh hops the amount increases during storage. Theoretically there are six pairs of enantiomers of humulene diepoxide but only five were formed by treatment of humulene with *m*-chloroperbenzoic acid: humulene diepoxides A-E (**8.142**–**8.145**). Humulene diepoxide A is the most abundant isomer and gives at least ten products on hydrolysis. There is considerable evidence that sesquiterpene oxidation products, and/or hydrolysis products therefrom, contribute to the hoppy aroma of beer although the actual compound(s) responsible have not been identified. Further, many lager brewers regard the aroma produced by the traditional European varieties such as Hallertauer mittelfrüh, Hersbrucker and Tettnang – the so-called ‘noble’ aroma – superior to that produced by other varieties. These hops produce high levels of sesquiterpene oxidation products and some brewers store their ‘aroma’ hops for a period to facilitate this oxidation. Humuladieneone (**8.148**) has been found in beer and associated with a hoppy aroma (Shimazu *et al.*, 1974). It is not a common oxidation product of humulene but it may be formed from humulenol II.

The minor sesquiterpenes will react with oxygen in a similar manner. β -Selinene (**8.110**, Fig. 8.23) can form two monoepoxides but only one (**8.149**) has been found in hop oil together with the related tertiary alcohol, selin-11-en-4-ol (**8.151**). Reduction of the other epoxide (**8.150**) would give β -eudesmol (**8.153**) which with α - (**8.154**) and δ -eudesmol (**9.155**) is found in hop oil. In a similar manner selina-3, 7(11)-diene (**8.115**) and selina-4(15), 7(11)-diene (**8.116**) would give juniper camphor (**8.152**) found in hop oil. Analogous reactions in the cadinene series (Fig. 8.19) lead to α - (**8.124**), δ - (**8.123**) and *T*-cadinol (**8.125**) also found in hop oil and beer. The tricyclic sesquiterpenes found in Hersbrucker spät hops (Fig. 8.20) can also form epoxides. Reduction of alloaromadendrene epoxide (**8.130**) gives ledol (**8.132**) and viridiflorol (**8.133**) while aromadendrene epoxide (**8.131**) gives globol (**8.134**) and epiglobol (**8.135**). Traces of these compounds probably occur in beers brewed with these hops.

Various oxygen heterocyclic compounds found in hop oil and beer are shown in Fig. 8.24. Compounds (**8.156**–**8.160**) were first characterized in Japanese hops but later found in German Spalter hops where the concentration was found to increase on storage. They are reported to contribute a flowery note to hop aroma. Various furans such as 5,5-

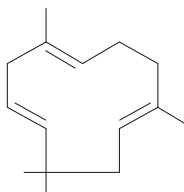

(8.111)
humulene

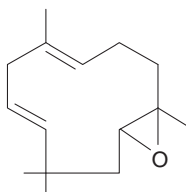

(8.139)
humulene epoxide I

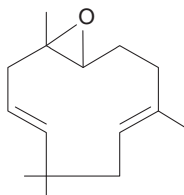

(8.140)
humulene epoxide II

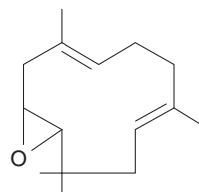

(8.141)
humulene epoxide III

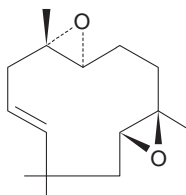

(8.142)
humulene diepoxide A

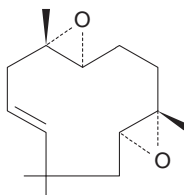

(8.143)
humulene diepoxide B

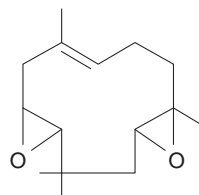

(8.144)
humulene diepoxide C

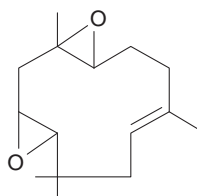

(8.145)
humulene diepoxide D & E

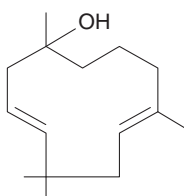

(8.146)
humulol

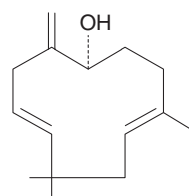

(8.147)
humulenol II

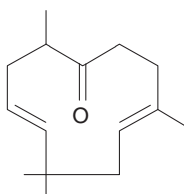

(8.148)
humuladienone

Fig. 8.22 Reactions of Humulene.

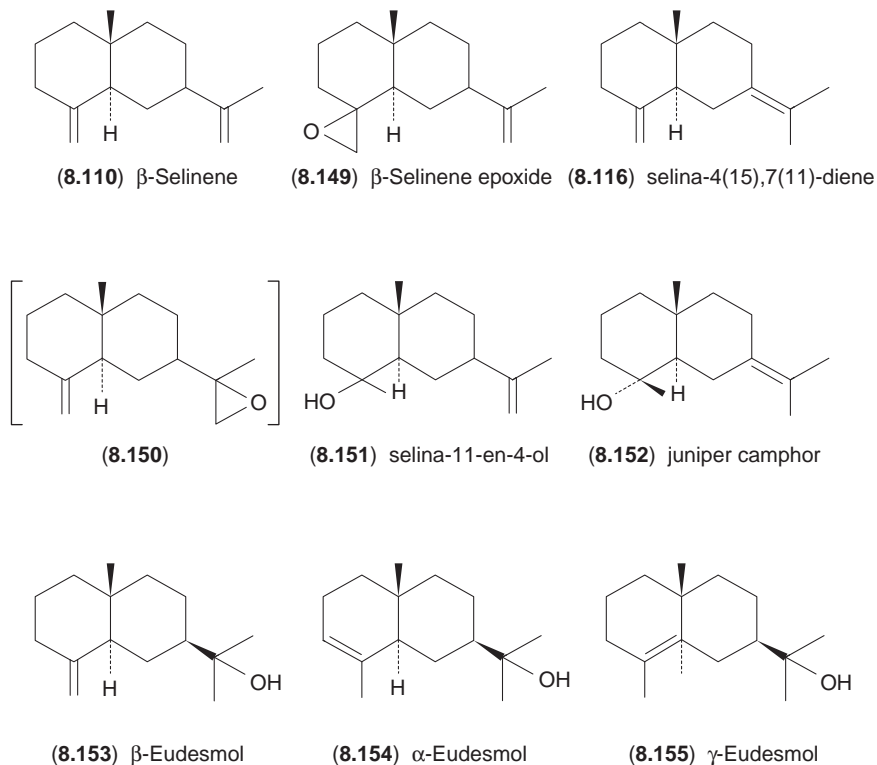
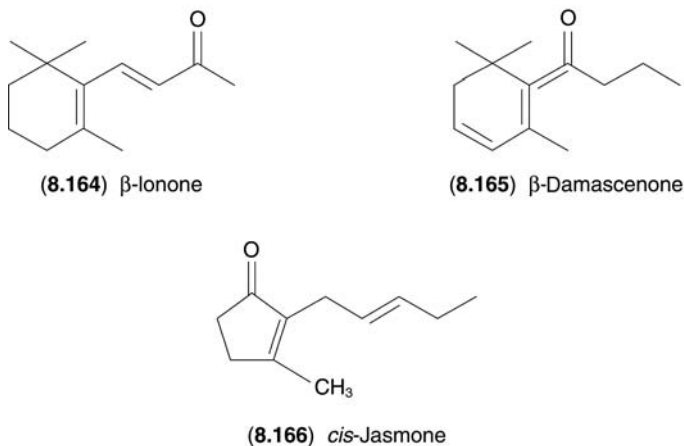

Fig. 8.23 Reactions of Selinene.

dimethyl-(5*H*)-furan-2-one (8.70), 2-hexyl-5-methylfuran, dendrolasin, perillene and compounds such as (8.163, R = Prⁱ, Buⁱ or CHMeEt) have been found in hop oil and beer (Moir, 1994). Probably more important for the overall hop aroma are the traces of β -ionone (8.164), β -damascenone (8.165) and *cis*-jasmone (8.166) reported. These have very low threshold values (see Table 8.6 on page 299); it is reported that some individuals can smell as little as 50 fg (10^{-15} g) of β -damascenone.



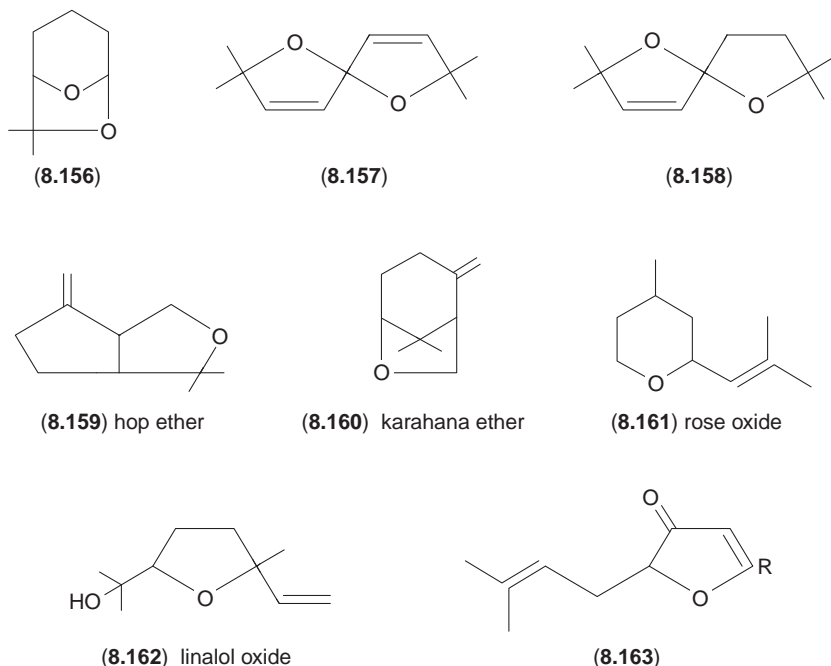

Fig. 8.24 Oxygen heterocyclic compounds in hop oil.

8.3.4 Sulphur-containing compounds

Only traces of sulphur-containing compounds are found in hop oil but many have very low flavour thresholds (Table 8.4). They can be detected by gas chromatography using either a flame photometric or a Sievers' chemiluminescence detector. Hops in the field may be treated with elemental sulphur to control mildew and it used to be common practice to burn sulphur in the oast. Both of these treatments can influence the spectrum of sulphur-containing compounds in the oil. For example, the sesquiterpenes caryophyllene and humulene can react with elemental sulphur under mild conditions to give episulphides such as (8.137), (8.139) and (8.140) where sulphur replaces oxygen. The level of these compounds is higher in oils that have been steam distilled at 100 °C than in those obtained by vacuum distillation at 25 °C. Thus more of these compounds will be introduced into beer by late hopping than by dry hopping. Myrcene also reacts with sulphur but less readily than the sesquiterpenes. However, with a suitable activator, a mixture of at least ten sulphur-containing compounds was formed of which (8.167) is the major component and this has been found in hop oil.

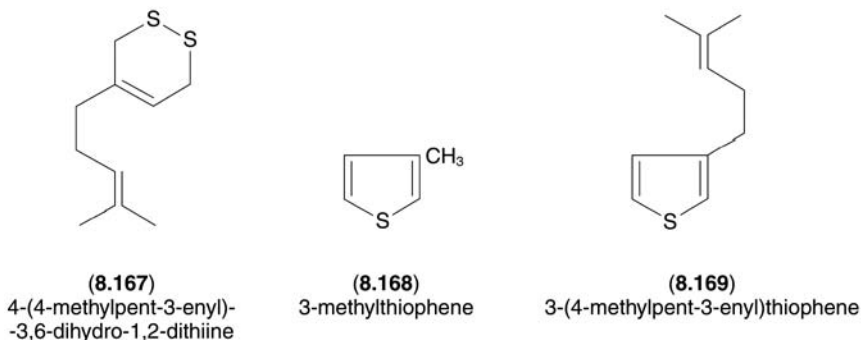

Table 8.4 Sulphur compounds in the essential oil of hops

Name	Structure	Flavour threshold (ppb)
Methanethiol	CH ₃ SH	0.02
Dimethyl sulphide	CH ₃ .S.CH ₃	7.5
Dimethyl disulphide	CH ₃ .S.S.CH ₃	7.5
Dimethyl trisulphide	CH ₃ .S.S.S.CH ₃	0.1
(2, 3, 4-Trithiapentane)		
2, 3, 5-Trithiahexane	CH ₃ .S.S.CH ₂ .S.CH ₃	–
Dimethyl tetrasulphide	CH ₃ .S.S.S.S.CH ₃	0.2
(2, 3, 4, 5-Tetrathiahexane)		
<i>S</i> -Methyl 2-methylpropanethioate	(CH ₃) ₂ CH.CO.S.CH ₃	40 (5)
<i>S</i> -Methyl 2-methylbutanethioate	CH ₃ CH ₂ CH(CH ₃)CO.S.CH ₃	1
<i>S</i> -Methyl 3-methylbutanethioate	(CH ₃) ₂ CH.CH ₂ .CO.S.CH ₃	50
<i>S</i> -Methyl pentanethioate	CH ₃ .(CH ₂) ₃ .CO.S.CH ₃	10
<i>S</i> -Methyl 4-methylpentanethioate	(CH ₃) ₂ CH.CH ₂ CH ₂ CO.S.CH ₃	15
<i>S</i> -Methyl hexanethioate	CH ₃ (CH ₂) ₄ CO.S.CH ₃	1
<i>S</i> -Methyl heptanethioate	CH ₃ (CH ₂) ₅ CO.S.CH ₃	–
<i>S</i> -Methylthiomethyl 2-Methylbutanethioate	CH ₃ CH ₂ CH(CH ₃)CO.S.CH ₂ S.CH ₃	1
<i>S</i> -Methylthiomethyl 3-Methylbutanethioate	(CH ₃) ₂ CH.CH ₂ CO.S.CH ₂ S.CH ₃	–
3-Methylthiophene	(8.168)	500
3-(4-Methylpent-3-enyl)thiophene	(8.169)	–
4-(4-Methylpent-3-enyl)-3, 6-dihydro-1, 2-dithiine	(8.167)	10
4, 5-Epithiocaryophyllene	(8.137) with S in place of O	200
1, 2-Epithiohumulene	(8.139) with S in place of O	1800
4, 5-Epithiohumulene	(8.141) with S in place of O	1500
2-Methyl-5-thiahex-2-ene	(CH ₃) ₂ C = CH.CH ₂ .S.CH ₃	0.2
Methylthiohumulene	C ₁₅ H ₂₄ .S.CH ₃	–

Polysulphides also occur in hop oil. Dimethyl trisulphide (2, 3, 4-trithiapentane) is found only in hops that have not been treated with sulphur (dioxide) on the kiln. It is formed during steam distillation at 100 °C from (*S*)-methylcysteine sulphoxide (CH₃SO.CH₂CH(NH₂)CO₂H) which is destroyed when sulphur is burnt on the kiln but slowly regenerates during storage. Dimethyl tetrasulphide and 2, 3, 5-trithiahexane have also been found in hop oil. These polysulphides have cooked vegetable, onion-like, rubbery sulphur aroma with low thresholds.

Thioesters are also present in hop oil (> 1000 ppm), the concentration of which does not appear to be influenced by treatment of the hops with sulphur or sulphur dioxide. They appear to be formed by the action of heat so only low levels will be introduced into beer by dry hopping. Few of the sulphur compounds discussed survive wort boiling but late addition of hops introduces traces of these compounds, including thioesters, into wort. During fermentation dimethyl trisulphide and some thioesters are lost but some sulphur volatiles survive into beer, in particular, *S*-methyl 2-methylbutylthioate. This ester and *S*-methyl hexanethiolate are the major thioesters introduced into beer by dry hopping. In the sample of Brewers' Gold hops discussed above Guadagni *et al.* (1966) found that methyl thiohexanoate contributed 4.8% of the total odour units.

8.3.5 Most potent odorants in hop oil

The pioneering work of Guadagni *et al.* (1966), discussed above, suggests that myrcene, methyl thiohexanoate, methyl 4-decenoate, caryophyllene and humulene are the most potent odorants in Brewers' Gold hops. Using a gas chromatography-olfactometry (GC-O) technique called 'Osme' Sanchez *et al.* (1992) found that linalol (**8.87**), neral (**8.94**) and humulene epoxide III (**8.141**) were the most potent odorants in Hallertau mittelfrüh and Mount Hood hops. Steinhaus and Schieberle (2000) used another GC-O technique – Aroma Extract Dilution Analysis (AEDA) – to examine an extract of Spalter Select hops. First, 36 areas were identified on the gas chromatogram by olfactory analysis. The extract was then diluted with an equal volume of diethyl ether and the analysis repeated. Further dilutions were made until no aroma was detected. The Flavour Dilution value (FD) is the highest dilution at which the aroma can be detected. The results of this study with dried and undried Spalter Select hops is given in Table 8.5 together with the results of a headspace analysis of the dried hops. Twenty-three odorants (FD > 4) were identified. In green undried hops (*Z*)-3-hexenal and linalol were the most potent odorants. Much of the (*Z*)-3-hexenal was lost during drying after which the most potent odorant was *trans*-4, 5-epoxy-(*E*)-2-decenal (**8.171**), probably formed by thermal cleavage of 12, 13-epoxy-9-hydroperoxy-11-octadecenoates (**8.170**).

Table 8.5 Most odour-active compounds in hops cv. Spalter Select (Flavour Dilution values) (Steinhaus and Schieberle, 2000)

	Undried	Dried	Headspace*
1a. Ethyl 2-methylpropionate	128	128	32
2. Methyl 2-methylpropionate	256	128	16
3a. (<i>Z</i>)-3-hexenal	2048	16	
3b. Hexanal		16	
4. Ethyl 2-methylbutanoate	32	16	16
9. Propyl 2-methylbutanoate	16	64	8
Dimethyl trisulphide			16
11. 1-Octen-3-one	32	32	1
12. (<i>Z</i>)-1, 5-Octadien-3-one	32	32	2
13. Myrcene	512	1024	256
Octanal	8	8	1
17. Phenylacetaldehyde	16		
20. Linalol	2048	2048	256
21. Nonanal	64	218	
14. (<i>E, Z</i>)-2, 6-Nonadienal	16	4	1
23a. 1, 3(<i>E</i>), 5(<i>Z</i>)-Undecatriene		128	
23b. 1, 3(<i>E</i>), 5(<i>Z</i>), 9-Undecatetrene		128	
15. 4-Ethenyl-2-methoxyphenol	32	32	
<i>trans</i> -4, 5-Epoxy-(<i>E</i>)-2-decenal	512	4096	
33. Humulene	16	8	
37. Butanoic acid		32	
38. 2-Methylbutanoic acid		64	
3-Methylbutanoic acid			
39. Pentanoic acid		4	

* Relative FD. Unidentified compounds (FD < 32) omitted.

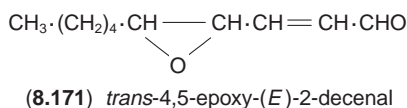
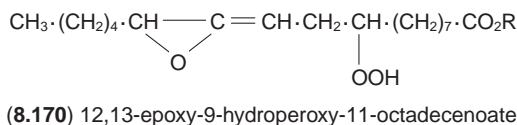

After this fatty acid oxidation product, linalol and myrcene were the most potent odorants in dried hops followed by ethyl and methyl 2-methylpropionate, (*Z*)-1,5-octadien-3-one, nonanal, 1,3(*E*),5(*Z*)-undecatriene and 1,3(*E*),5(*Z*),9-undecatetraene. In the headspace of the dried hops myrcene and linalol were again the most potent odorants. The sesquiterpene epoxides are probably not sufficiently volatile to be found in these studies. It is noteworthy that none of the odorants characterized in these studies was classed as 'hoppy'. This suggests that the typical hop aroma is probably due to a synergistic effect. However, it is possible there is an, as yet unknown, highly potent 'hoppy' odorant (Siebert, 1994).

8.3.6 Hop oil constituents in beer

Quantitatively, any contribution that the hop makes to beer volatiles will be dwarfed by ethanol and other volatile products of fermentation. Also, during fermentation, carbonyl compounds and possibly epoxides may be reduced to alcohols. The first detailed study of hop volatiles in a German Pilsener beer was by Tressl *et al.* (1978) who characterized 47 compounds in beer which were known constituents of Spalter hops. These included 28 terpenoids and sesquiterpenoids (Table 8.6). Also included in Table 8.6 are the threshold values, collected from various sources, from which it is possible to judge which compounds make an important contribution to the overall flavour. However, it is often difficult to obtain some of these odorants sufficiently pure to obtain accurate threshold values (Siebert, 1994). From Table 8.6 it appears that hop ether (8.159), karahana ether (8.160), linalol and, perhaps, β -ionone and β -damascenone make important contributions to the hop aroma in beer. Humulene epoxide I may contribute but humulene epoxide II, humulol and humuleneol II do not produce sufficient flavour units. However, the hydrolysis mixture from humulene epoxide II, with a cedar, lime, banana character, may influence the overall flavour (Deinzer and Yang, 1994). Goiris *et al.* (2002) obtained an oxygenated sesquiterpene fraction which when added to beer after fermentation produced spicy or herbal flavour notes reminiscent of typical 'noble' hop aroma.

Peacock *et al.* (1980) examined pilot brews made with Hallertau mittelfrüh and Washington Cluster hops and found that the Hallertau brew contained higher levels of α -terpineol, humulene epoxide I, humulol, *T*-cadinol (8.125), α -eudesmol (8.154) and humulenol II than the Cluster brew. Similarly, in an American commercial beer, brewed mainly with Hallertau mittelfrüh hops, caryolan-1-ol (8.138), humulene epoxide I, δ -cadinol (8.123) and α -eudesmol were found but these compounds were not detected in beers brewed with Cascade hops. Indeed Cascade hops introduced a floral hop aroma into

Table 8.6 Terpenoids and sesquiterpenoids characterized in beer (Tressl *et al.*, 1978)

Compound	Approx. conc. (ppb)	Threshold value (ppb)
(8.153)	5	—
(8.152)	10	—
(8.151)	50	—
Hop ether (8.159)	35	5 (in water)
Karahana ether (8.160)	60	5 (in water)
<i>trans</i> -Linalol oxide (8.157)	20	—
Humuladienone (8.148)	10	100
Caryophyllene epoxide (8.139)	18	—
Humulene epoxide I (8.137)	125	10 (in water)
Humulene epoxide II (8.140)	40	450
Linalol (8.87)	470	27
β -Fenchyl alcohol	40	—
Terpinen-4-ol	15	—
α -Terpineol (8.97)	40	2000
Citronellol (8.96)	10	—
Geraniol (8.90)	5	36
Caryolan-1-ol (8.138)	25	—
Nerolidol (8.104)	25	—
Juneol	5	—
<i>Epi</i> -Cubenol	20	—
Caryophyllenol	5	—
<i>T</i> -Cadinol (8.125)	45	—
Humulol (8.146)	220	2000
δ -Cadinol (8.123)	35	—
Humulenol II (8.147)	1150	2500
β -Ionone (8.164)	1	0.007
β -Damascenone (8.165)	Tr	0.002
<i>cis</i> -Jasmone (8.166)	10	—

All the above compounds were found in Spalter hops.

beer (Peacock *et al.*, 1981). Cascade hops contain high levels of linalol, geraniol and geranyl isobutyrate and produce beers in which the level of linalol and, in particular, geraniol exceed the threshold value (the threshold value of geranyl isobutyrate, 450 ppb, was not exceeded). All the hops examined contained linalol and Clusters, Talisman and Shin-shu-wase also contained high levels of geraniol. Geraniol was not found in Hallertau, Hersbrucker and Perle hops.

Moir *et al.* (1983) compared the hop oil constituents in copper hopped, late hopped and dry hopped beers. They found 40–75 ppb of hop oil constituents in copper hopped beer, the major constituents being humulene-8, 9-epoxide (8.139) and β -humulen-1-ol. In late hopped lagers they found, in addition, linalol, methyl geranate, 2-nonanol and 2-undecanol. In dry hopped ales they found myrcene, linalol, 2-undecanone, and the esters isobutyl isobutyrate, isoamyl isobutyrate, isoamyl isovalerate and methyl 4-decenoate.

Nickerson and Van Engel (1992), following Foster and Nickerson (1985), regarded the 22 components listed in Table 8.7 as being important for the hop aroma of beer. It will be noted that in addition to the oxidation products and the floral-estery compounds they included a number of citrus-piney compounds. They measured the concentration of these compounds individually and as a group in hops (nl/g) and in beer (μ l/l). They regarded the sum of the amount of oil components in the three groups as Hop Aroma Units. Having

Table 8.7 Classification of hop aroma constituents (Nickerson and Van Engel, 1992)

Oxidation products	Floral compounds	Citrus-piney compounds
(Caryolan-1-ol)	Geraniol	δ -Cadinene
Caryophyllene oxide	Geranyl acetate	γ -Cadinene
(Humulene diepoxide A)	Geranyl isobutyrate	(Citral)
Humulene diepoxide B	Linalol	Limonene
(Humulene diepoxide C)		(Limonene-10-ol)
Humulene epoxide I		α -Muurolene
Humulene epoxide II		(Nerol)
Humulene epoxide III		β -Selinene
Humuleneol I		
Humulol		

Compounds not usually detected in steam-distilled oil from fresh hops are in parentheses.

determined the Hop Aroma Units needed to produce a desirable beer, Van Engel and Nickerson (1992) used this concept to calculate the late hop addition required to produce beers of consistent hoppiness. They found that during hop storage the Aroma Units and the amount of α - and β -acids varied independently of each other. Therefore, the bitterness was determined by the addition of bitter hops to the kettle after making allowance for the α -acids in the aroma hops.

Lermusieau *et al.* (2001) used aroma extract dilution analysis (AEDA) to compare three beers; one brewed without hops, one brewed with Saaz hops and one brewed with Challenger hops (added seven minutes before the end of the 75 min. boil). Forty-five odours were detected in the unhopped beer with an additional 15 in the beers treated with Saaz hops and 16 in the beers treated with Challenger hops. Those with an FD \geq 16 in the hopped beers included dimethyl trisulphide, γ -nonalactone and components suspected to be *N*-methylmercaptoacetamide, β -damascenone and ethyl cinnamate. An unknown compound in hopped beers (initially thought to be 3-mercaptobutan-2-ol) gave the highest FD values and was also present in the hops used. Saaz pellets were readily distinguishable from Challenger pellets by AEDA; Challenger pellets were richer in sulphur compounds notably dimethyl disulphide and diethyl disulphide.

8.3.7 Post fermentation aroma products

Products added to bright beer must be completely soluble to achieve 100% utilization and a reproducible flavour. Further filtration would remove both bitter and aroma products indiscriminately. Addition of whole hop oils and products containing them such as emulsions or oil rich fractions are likely to produce a haze. In hop oil, whether produced by steam distillation or molecular distillation of a CO₂ extract, the hydrocarbon fraction is much less soluble, and contains less FU/g, than the oxygenated fraction. Thus, starting with a molecularly distilled CO₂ extract, which retains the aroma of the parent hop, by liquid/liquid separation a sesquiterpene-less oil can be obtained with the true aroma of the hop. A 1% solution of this sesquiterpene-less oil in ethanol is known as a Dry Hop Essence which can be added to bright beer (250 μ g/l) to impart a hoppy aroma. Such dry hop essences can be prepared from a single cultivar of hops giving more control of the hop aroma produced (Marriott, 1999).

Table 8.8 Flavour descriptors associated with late hop essences (Marriott, 1999)

Spicy-LHE	Floral-LHE	Estery-LHE	Citrusy-LHE
Sandalwood	Geranium	Pear skin	Lemon
Oakmoss	Neroli	Pineapple	Grapefruit
Astringent	Rose	Fruity	Bergamot
Synergist	Lavender	Sweet	Lime

It is generally held that late hopping and dry hopping produce different aromas in beers; late-hopped beers are said to have hoppy, fruity-citrus, floral and fragrant flavours. By column chromatography of a CO₂ extract Westwood and Daoud (1985) produced a Late Hop Essence, which when added (150–200 ppb) to bright beer could not be distinguished from a late-hopped beer. This essence contained at least 130 compounds including linalol (6–20%), humulene, linalol oxide, caryophyllene oxide, hop ether and humulene epoxide(s). Further fractionation (Gardner, 1994) led to four late hop essences (Table 8.8). The ‘spicy’ fraction is composed of mono- and sesquiterpene alcohols, the ‘floral’ fraction is principally ketones, epoxides and esters, the ‘estery’ fraction is composed exclusively of methyl esters of C₆ to C₁₀ branched and straight chain fatty acids, and the ‘citrusy’ fraction is a complex mixture of terpene alcohols, ketones, and C₅ to C₈ aliphatic alcohols (Marriott, 1999). These essences are typically used at 50–100 µg/l and are supplied as 1% solutions in ethanol.

8.4 Hop polyphenols (tannins)

Hops contain 0.8–1.5% polyphenols; the amount and composition of this fraction depends on the cultivar and growing history of the hop examined. By HPLC Forster *et al.*, (1995, 1996) found over 100 compounds in the polyphenol fraction of hops. Many of these constituents are also found in malt including the hydroxycinnamic acids, the hydroxybenzoic acids and chlorogenic acid (**4.133**); gallic acid (**4.125**) has long been known as a constituent of hops. Jerumanis (1985) found 817–2821 mg/kg of (+)-catechin (**4.138**) in hops and the related epi-catechin (**4.139**) has been reported. Jerumanis also found 428–1472 mg/kg of procyanidin B-3 (**4.143**) and 287–875 mg/kg of procyanidin C-2 (**8.172**) in hops; the highest concentration being found in Saaz hops. Acid treatment of these procyanidins will liberate the red pigment cyanidin (**4.136**) but similar treatment of hop polyphenols also liberates delphinidin (**4.135**) indicating that prodelphinidin compounds are present. Indeed the cyanidin:delphinidin ratio (1.2–6.2) may be a varietal characteristic (McMurrough, 1981). In beer proanthocyanidins will slowly react with the proteins present to form a non-biological haze which will limit the shelf-life of bottled beers. Brewers use various treatments to remove proanthocyanidins and increase the shelf-life of their beers (Chapter 15). Normally, malt contributes more of these compounds to beer than hops but the breeding and use of proanthocyanidin-free barley varieties such as Caminant and Clarity leave hops as the major source of these materials. Beers brewed with a proanthocyanidin-free malt and bittered with a pure hop resin extract are said to lack character.

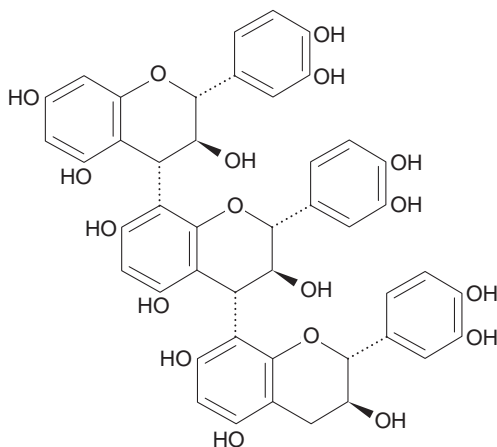
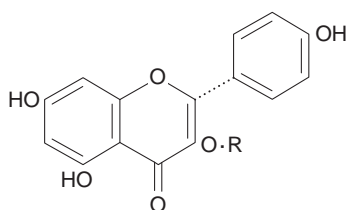
(8.172) procyanidin C₃ (trim α C₈₋₄, β C₈₋₄, γ C)

(8.173)

It was mentioned above that the lupulin glands appear to lack the enzyme chalcone cyclase but this must be present elsewhere in the hop since the flavanols kaempferol (8.57) and quercetin (8.58) are found in the polyphenol fraction mainly as their glycosides. Fourteen glycosides have been characterized in hops including quercitrin (8.58, R = rhamnosyl, R' = H), isoquercitrin (8.58, R = β-D-glucosyl, R' = H), rutin (8.58, R = β-L-rhamnosido-6-β-D-glucosyl) and astragalin (8.173, R = β-D-glucosyl). Recently the 3-*O*- (6'-*O*-malonyl)glucosides of kaempferol and quercetin have also been identified. It is noteworthy that phloroglucinol (8.18) and phlorisobutyrophenone β-D-glucoside, putative intermediates in the biosynthesis of the hop resins, have been found in the hop polyphenols.

8.5 Chemical identification of hop cultivars

Hop cultivars can now be determined by DNA typing but this technique is not widely available so interest remains in identification by chemical means. From the resins the percentage of cohumulone in the α-acids (and colupulone in the β-acids) is a varietal factor (Table 7.3) but more information can be obtained from essential oil analyses. By inspection of the gas chromatograms of the essential oil, or oils obtained by molecular distillation of CO₂ extracts, experienced analysts can usually suggest the cultivar from which the oil came. Numerically the humulene/caryophyllene ratio (Table 7.3) and perhaps the selinene/caryophyllene ratio are varietal characteristics. Stenroos and Siebert (1984) applied pattern recognition and multivariate analysis techniques to hop oil

chromatograms and found that SIMCA and Stepwise Discriminant Analysis were most successful in classifying the major hop varieties. Perpete *et al.* (1998) examined the oils obtained from pellets of twelve varieties and developed a flow chart to distinguish between them and Lermusieau and Collin (2001) extended the work to aged samples. De Cooman *et al.* (1998) studied only three varieties : Saaz, Nugget and Wye Target, but by three different techniques. The cophumulone ratio only distinguished Saaz from the other two varieties but essential oil analyses separated all three varieties. They also used flavonoid analyses, the glycosides of quercetin and kaempferol, which readily distinguished Wye Target from the others. The application of these techniques to more varieties is promised.

8.6 References

- AITKEN, R. A., BRUCE, A., HARRIS, J. O. and SEATON, J. C. (1970) *J. Inst. Brewing*, **76**, 29.
- ALDERTON, G., BAILEY, G. F., LEWIS, J. C. and STITT, F. (1954) *Analyt. Chem.*, **26**, 983.
- ALDERWEIRELDT, F., ANTEUNIS, M., DIERCKENS, J. and VERZELE, M. (1965) *Bull. Soc. Chim. Belg.*, **74**, 29.
- ASHURST, P. R. and LAWS, D. (1966) *J. Chem. Soc. C.*, 1615.
- ASHURST, P. R. and LAWS, D. (1967) *J. Inst. Brewing*, **73**, 535.
- BAKER, C. W. (1990) *Tech. Quart. MBAA*, **27**, 33.
- BAXTER, E. D. and HUGHES, P. S. (2001) *Beer: Quality, Safety and Nutritional Aspects*. Royal Society of Chemistry, Cambridge, pp. xiv + 138.
- BENITEZ, J. L., FOSTER, A., DE KEUKELEIRE, D., MOIR, M., SHARPE, F. R., VERHAGEN, L. C. and WESTWOOD, K. T. (1997) *European Brewery Convention Manual of Good Practice, Hops and Hop Products*, pp. xiv + 186. Verlag Hans Carl, Nürnberg.
- BURTON, J. S., STEVENS, R. and ELVIDGE, J. A. (1964) *J. Inst. Brewing*, **70**, 345.
- CAHN, R. S., INGOLD, C. and PRELOG, V. (1951) *J. Chem. Soc.*, 612.
- CAHN, R. S., INGOLD, C. and PRELOG, V. (1956) *Experientia*, **12**, 81.
- CAHN, R. S., INGOLD, C. and PRELOG, V. (1966) *Angewandte Chemie*, **78**, 413.
- CLARKE, B. J. and HILDEBRAND, R. F. (1965) *J. Inst. Brewing*, **71**, 26.
- COLLINS, E. and SHANNON, P. V. R. (1973) *J. Chem. Soc. Perkin I*, 419.
- COLLINS, M. and LAWS, D. R. J. (1973) *J. Chem. Soc. Perkin I*, 2013.
- COLLINS, M., LAWS, D. R. J., MCGUINNESS, J. D. and ELVIDGE, J. A. (1971) *J. Chem. Soc.*, 3814.
- DE COOMAN, L., EVERAERT, E. and DE KEUKELEIRE, D. (1998) *Phytochem. Anal.*, **9**, 145.
- DE COOMAN, L., AERTS, G., OVERMEIRE, H. and DE KEUKELEIRE, D. (2000) *J. Inst. Brewing*, **106**, 169.
- DEINZER, M. and YANG, X. (1994) *EBC Monograph XXII Symposium on Hops, Zoeterwoude*, p. 181.
- DE KEUKELEIRE, D. and VERZELE, M. (1970) *Tetrahedron*, **26**, 385.
- DE KEUKELEIRE, D. and VERZELE, M. (1971) *Tetrahedron*, **27**, 4939.
- EISENREICH, W., SCHWARZ, M., CARTAYRADE, A., ARIGONI, D., ZENK, M. H. and BACHER, A. (1998) *Chemistry & Biology*, **5**, R221.
- EUROPEAN BREWERY CONVENTION. (1994) *Monograph XXII. Symposium on Hops, Zoeterwoude*, xviii + 300 pp.
- EUROPEAN BREWERY CONVENTION (1997) *see Benitez et al.*
- FERNANDEZ, C. M. (1967) *Chem. Commun.*, 1212
- FORSTER, A., BECK, B. and SCHMIDT, R. (1995) *Proc. 25th Congr. Eur. Brew. Conv. Brussels*, p. 143
- FORSTER, A., BECK, B. and SCHMIDT, R. (1996) *Proc. 24th Conv. Asia-Pacific Section Institute of Brewing, Singapore*, p. 243.
- FOSTER, R. T. and NICKERSON, G. B. (1985) *J. Amer. Soc. Brew. Chem.*, **43**, 127.
- FUNG, S. Y., ZUURBIER, K. W. M., PANIEGO, N. B., SCHEFFER, J. J. C. and VERPORTE, R. (1997) *Proc. 26th Congr. Eur. Brew. Conv. Maastricht*, 1997, 215.
- GARDNER, D. S. J. (1994) in *EBC Symposium on Hops, Zoeterwoude*, p. 114.
- GLASER, G. (2002) *Modern Brewery Age*, **53** (12), 6, 32.
- GOESE, M., KAMMHUBER, K., BACHER, A., ZENK, M. H. and EISENREICH, W. (1999) *Eur. J. Biochem.*, **263**, 447.
- GOIRIS, K., DE RIDDER, M., DE ROUCK, G., BOEYKENS, A., VAN OPSTALE, F., AERTS, G., DE COOMAN, L. and DE KEUKELEIRE, D. (2002) *J. Inst. Brew.*, **108**, 86.
- GOLDSTEIN, H., TING, P., NAVARRO, A. and RYDER, P. (1999) *Proc. 27th Congr. Eur. Brew. Conv., Cannes*, p. 53.
- GREEN, C. P. (1978) *J. Inst. Brewing*, **84**, 312.
- GUADAGNI, D. G., BUTTERY, R. G. and HARRIS, J. (1966) *J. Sci. Food Agric.*, **17**, 142.

- HAY, B. A. and HOMISKI, J. W. (1991) *J. Agric. Food Chem.*, **39**, 1732.
- HERMANS-LOCKKERBOL, A. C. J. and VERPORTE, R. (1994) *J. Chromatography A*, **664**, 45.
- HEYERICK, A., ZHAO, Y., SANDRA, P., HUYAERE, K., ROELEN, F. and DE KEUKELEIRE, D. (2003) *Photochem. Photobiol. Sci.*, **2**, 306.
- HUGHES, P. S. (1996) *J. Chromatography A*, **731**, 327.
- HUGHES, P. S. (2000) *J. Inst. Brewing*, **106**, 271.
- HUGHES, P. S. and SIMPSON, W. J. (1996) *J. Amer. Soc. Brew. Chem.*, **54**, 234.
- HUGHES, P. S., MENNEER, I. D., WALTERS, M. T. and MARINOVA, G. (1997) *Proc. 26th Congr. Eur. Brew. Conv., Maastricht*, p. 231.
- JERUMANIS, J. (1985) *J. Inst. Brewing*, **91**, 250.
- KANEDA, H., KANO, Y., KOSHINO, S. and OHYA-NISHIGUCHI (1992) *J. Agric. Food Chem.*, **40**, 2102.
- KOLLER, H. (1969) *J. Inst. Brewing*, **75**, 175.
- LERMUSIEAU, G. and COLLIN, S. (2001) *J. Am. Soc. Brew. Chem.*, **59**, 39.
- LERMUSIEAU, G., BULENS, M. and COLLIN, S. (2001) *J. Agric. Food Chem.*, **49**, 3867.
- LIKENS, S. T., NICKERSEN, G. B. and ZIMMERMANN, C. E. (1970) *Proc. Am. Soc. Brew. Chem.*, p. 68.
- MACWILLIAM, I. C. (1953) *J. Inst. Brewing*, **59**, 142, 480.
- MARRIOTT, R. (1999) *Proc. 7th Conv. Inst. Brewing, Africa Section, Nairobi*, p. 140.
- MAYE, J. P., MULQUEEN, S., WEIS, S. XU, J. and PRIEST, M. (1999) *J. Amer. Soc. Brew. Chem.*, **57**, 55.
- McMURROUGH, I. (1981) *J. Chromatography*, **218**, 683.
- MOIR, M. (1994) *EBC Monograph XXII – Symposium on Hops, Zoeterwoude*, p. 165.
- MOIR, M. (2000) *J. Amer. Soc. Brew. Chem.*, **58**, 131.
- MOIR, M. and SMITH, R. J. (1995) *Proc. 20th Congr. Eur. Brew. Conv., Brussels*, p. 125.
- MOIR, M., SEATON, J. C. and SUGGERT, A. (1983) *Proc. 19th Congr. Eur. Brew. Conv. London*, p. 63.
- MOLTKE, A. B. and MEILGAARD, M. (1955) *Brygmesteren*, **12**, 65.
- NICKERSON, G. B. and LIKENS, S. T. (1979) *J. Amer. Soc. Brew. Chem.*, **37**, 184.
- NICKERSON, G. B. and VAN ENGEL, E. L. (1992) *J. Amer. Soc. Brew. Chem.*, **50**, 77.
- NOMENCLATURE SUB-COMMITTEE: HOPS LIAISON COMMITTEE (1969) *J. Inst. Brewing*, **75**, 340.
- PEACOCK, V. (1998). *Tech. Quart. MBAA*, **35** (1), 4.
- PEACOCK, V. E., DEINZER, M. L., MCGILL, L. A. and WROLSTAD, D. E. (1980) *J. Agric. Food Chem.*, **28**, 774.
- PEACOCK, V. E., DEINZER, M. L., LIKENS, S. T., NICKERSON, G. B. and MCGILL, L. A. (1981) *J. Agric. Food Chem.*, **29**, 1265.
- PERPÈTE, P., MÉLOTTE, L., DUPIRE, S. and COLLINS, S. (1998) *J. Am. Soc. Brew. Chem.*, **56**, 104.
- PFFENNINGER, H. B., SCHUR, F., VATERLAUS, B. P., SIGG, T. and WILD, J. (1975) *Proc. 15th Congr. Eur. Brew. Conv., Nice*, p. 159.
- POWER, F. B., TUTIN, F. and ROGERSON, H. (1913) *J. Chem. Soc.*, **103**, 1267.
- RIEDL, W. (1951) *Brauwissenschaft*, 81.
- RIEDL, W. (1954) *Ann.*, **585**, 38.
- RIEDL, W., NICKL, J., RISSE, K. H. and MITTELDORF, R. (1956) *Ber.*, **89**, 1849.
- RIGBY, F. L. (1972) *Proc. Ann. Meet. Amer. Soc. Brew. Chem.*, 46.
- RIGBY, F. L. and BETHUNE, J. L. (1955) *J. Inst. Brewing*, **61**, 325.
- RILLAERS, G. and VERZELE, M. (1962) *Bull. Soc. Chim. Belg.*, **71**, 438.
- ROHMER, M. (1998) *Progress in Drug Research*, **50**, 136–154.
- SANCHEZ, N. B., LEDERER, C. L., NICKERSON, G. B., LIBBY, M. L. and McDANIEL, M. R. (1992) *Food Science and Human Nutrition Charambous*, G. (ed.) Elsevier, Amsterdam, p. 370.
- SHARPE, F. R. and LAWS, D. R. J. (1981) *J. Inst. Brewing*, **87**, 96.
- SHARPE, F. R. and ORMROD, H. (1991) *J. Inst. Brewing*, **97**, 31.
- SHIMAZU, T., HASHIMOTO, N. and KUROIWA, Y. (1974). *Proc. Amer. Soc. Brew. Chem.*, **33**, 7.
- SIEBERT, K. J. (1994) *EBC Monograph XXII. Symposium on Hops, Zoeterwoude* pp. 198, 215.
- SIGG-GRUTTER, T. and WILD, J. (1974) Swiss Patent, 1458 343.
- SIMPSON, W. J. (1993a) *J. Inst. Brewing*, **99**, 317.
- SIMPSON, W. J. (1993b) *J. Inst. Brewing*, **99**, 405.
- SIMPSON, W. J. and SMITH, A. R. W. (1992) *J. Applied Bacteriology*, **72**, 327.
- SMITH, R. J., DAVIDSON, D. and WILSON, R. J. H. (1998) *J. Amer. Soc. Brew. Chem.*, **56**, 52.
- SPETSIG, L. O. (1955) *Acta Chem. Scand.*, **9**, 1421.
- SPETSIG, L. O. (1964) *J. Inst. Brewing*, **70**, 440.
- STEINHAUS, M. and SCHIEBERLE, P. (2000) *J. Agric. Food Chem.*, **48**, 1776.
- STENROOS, L. E. and SIEBERT, K. J. (1984) *J. Am. Soc. Brew. Chem.*, **42**, 54.
- STEVENS, J. F., IVANCIC, M., HSU, V. L. and DEINZER, M. (1997) *Phytochemistry*, **44**, 1575.
- STEVENS, J. F., MIRANDA, C. L., BUHLER, D. R. and DEINZER, M. L. (1998) *J. Amer. Soc. Brew. Chem.*, **56**, 136.
- STEVENS, J. F., TAYLOR, A. W., CLAWSON, J. E. and DEINZER, M. L. (1999) *J. Agric. Food Chem.*, **47**, 2421.
- STEVENS, R. (1967) *Chem. Rev.*, **67**, 19.
- STEVENS, R. (ed.) (1987) *An Introduction to Brewing Science and Technology. Series II Volume I. Hops*. Institute of Brewing, London, pp. vi + 118.

- THORNTON, H. A., KULANDAI, J., BOND, M., JONTEF, M. P., HAWTHORNE, D. B. and KAVENAGH, T. E. (1993) *J. Inst. Brewing*, **99**, 473.
- TRESSL, R., FRIESE, L., FENDESACK, F. and KOPPLER, H. (1978) *J. Agric. Food Chem.*, **26**, 1422.
- TRESSL, R., ENGEL, K.-H., KOSSA, M. and KOPPLER, H. (1983) *J. Agric. Food Chem.*, **31**, 892.
- VAN ENGEL, E. L. and NICKERSON, G. B. (1992) *J. Amer. Soc. Brew. Chem.*, **50**, 82.
- VERZELE, M. (1958) *Bull. Soc. Chim. Belg.*, **67**, 278.
- VERZELE, M. and DE KEUKELEIRE, D. (1991) *Chemistry and Analysis of Hop and Beer Bitter Acids*. Elsevier, Amsterdam, xx + 417 pp.
- WESTWOOD, K. T. and DAOUD, I. S. (1985) *Proc. 20th Congr. Eur. Brew. Conv., Helsinki*, p. 579.
- WHITEAR, A. L. (1965) *Proc. 10th Congr. Eur. Brew. Conv., Stockholm*, p. 405.
- WHITEAR, A. L. (1966) *J. Inst. Brewing*, **72**, 177.
- WINDISCH, W., KOLBACH, P. and SCHLEICHER R. (1927) *Wochschr. Brau.*, **44**, 453.

9

Chemistry of wort boiling

9.1 Introduction

Wort boiling may be regarded as the turning point in the brewing of beer; it is omitted in distilling and vinegar brewing. At its simplest, in Bavarian practice, the all-malt wort is boiled with hops for 1–2 h at atmospheric pressure. Elsewhere, the sweet wort may be produced from a mixed cereal grist and additional carbohydrate, either brewing sugars or wort syrups, may be added to the copper. The boiling vessels were originally made from copper so are often called coppers although today they are more likely to be made of stainless steel. In the USA the wort boiling vessels are called kettles. As pointed out in the last chapter, the addition of whole hops to the copper is likely to be replaced by hop pellets or extract. Alternatively, part or all of the hop grist to be added to the copper may be replaced by post-fermentation isomerized bittering agents and hop essences. After the wort has been boiled with whole hops, the copper is cast into a vessel with a slotted base called a hop back. A bed of spent hops is formed through which the wort is circulated until it runs bright, when it is run off, through a heat exchanger, into the fermentation vessel. Hop pellets and extracts do not provide a bed of spent hops for filtration and such worts are usually clarified in a whirlpool (see Chapter 10).

The EBC have published a *Manual of Good Practice – Wort Boiling and Clarification* (Denk *et al.*, 2000) in which they list the principal changes that occur during wort boiling as:

1. Inactivation of malt enzymes
2. Sterilization of the wort
3. Extraction and isomerization of compounds derived from hops
4. Coagulation of protein material in the wort
5. Formation of protein/polyphenol complexes
6. Formation of flavour and colour complexes
7. Formation of reducing substances to give the wort reducing potential, which is thought to protect the wort from oxidation later in the process
8. Fall in wort pH
9. Concentration of wort gravity through evaporation of water

10. Evaporation of volatile compounds in wort derived from mashing
11. Evaporation of volatile compounds in wort derived from hops.

Other reviews have been provided by Miedaner (1986) and O'Rourke (1999, 2002). Of the changes discussed above, the extraction and isomerization of compounds derived from hops has been discussed in Chapter 8.

Wort boiling requires a lot of energy (24–54 MJ/hl) and the increase in energy prices over the last few decades has led to many changes in plant design and practice to conserve energy (Chapter 10). However, any changes in wort boiling practice must be carefully monitored to ensure they do not affect the quality and flavour of the final beer. The rate of all chemical reactions increases with a rise in temperature. Boiling under pressure increases the temperature and so shortens the time necessary to complete the changes that occur during wort boiling. Low-pressure boiling (c. 1 bar of counter-pressure) will raise the temperature to 104–110 °C but not shorten the reaction times appreciably. However, boiling plants with temperatures of 118–122 °C will require a holding time of only 8–10 min. and those with a temperature range of 130–140 °C will require shorter times with a corresponding saving in energy consumption (see Chapter 10).

9.2 Carbohydrates

During mashing (Chapter 4), malt and adjunct polysaccharides, mainly starch, are enzymatically broken down to simpler units (Table 4.15). Carbohydrates are responsible for 90% of the extract, 68–75% of which is usually fermentable by yeast. Whole hops and pellets only contribute 0.15% of the total carbohydrates in hopped wort and most hop extracts, prepared with solvents, will contain no carbohydrate. The carbohydrates undergo little change during wort boiling so the carbohydrate composition of hopped wort (Table 9.1) is very similar to that of sweet wort. The rate of enzyme-catalysed reactions also increases with a rise in temperature but so does the rate of enzyme deactivation. Therefore the temperature 'optimum' for most enzyme reactions is a compromise between the two processes. For example, in mashing, the 'protein rest' at 50 °C is close to the 'optimum' temperature for proteases, peptidases and β -glucanase whereas amylases show higher 'optima' at 60–70 °C. Above this temperature the rate of enzyme deactivation dominates so that by 100 °C enzyme activity has ceased and the composition of the wort is fixed. In whisky manufacture, where the wort is not boiled, enzyme-catalysed reactions continue longer and few dextrans survive into the wash. Similarly, few micro-organisms will survive temperatures of 100 °C. The exceptions are thermophilic bacteria, mainly *Bacillus* sp., which form spores that survive wort boiling (see Chapter 17). However, standard beer is a poor growth medium for these organisms..

9.3 Nitrogenous constituents

9.3.1 Introduction

As discussed in Chapter 4, malt contains a range of nitrogenous constituents: proteins, peptides, and amino acids (Section 4.5.1), nucleic acids and related substances (Section 4.5.2), miscellaneous substances (Section 4.5.3), and vitamins (Section 4.6.1). Many of

Table 9.1 Carbohydrate composition of worts (results expressed in g/100 ml wort) (MacWilliam, 1968)

Origin (and ref.)	Danish ^{a,b}	Canadian ^c	Canadian ^d	Canadian ^d	German ^e	British ^f	British ^g
Type of wort	Lager	Lager	Lager	Grain lager	Lager	Pale ale	Pale ale
OG	1043.0	1054.0	1048.0	1046.5	1048.5	1040.0	1040.0
<i>Sugar</i>							
Fructose	0.21	0.15	0.13	0.10	0.39	0.33	0.97
Glucose	0.91	1.03	0.87	0.50	1.47	1.00	
Sucrose	0.23	0.42	0.35	0.10	0.46	0.53	0.60
Maltose	5.24	6.04	5.57	5.50	5.78	3.89	3.91
Maltotriose	1.28	1.77	1.66	1.30	1.46	1.14	1.30
Total ferm. sugar	7.87	9.41	8.58	7.50	9.56	6.89	6.78
Maltotetraose	0.26	0.72	0.54	1.27		0.20	0.53
Higher sugars	2.13*	2.68	2.52	2.94		2.32	1.95
Total dextrins	2.39	3.40	3.06	4.21		2.52	2.48
Total sugars	10.26	12.81	11.64	11.71		9.41	9.26
Sugars (% total extract)	91.1						
Fermentability	76.7	73.7	73.7	64.1		73.3	73.2

* The contents of maltopentanose, maltohexanose and maltoheptanose in this wort were 0.13, 0.19 and 0.18 g/100 ml wort, respectively.

- (a) Gjertsen (1953)
- (b) Gjertsen (1955)
- (c) McFarlane and Held (1953)
- (d) Latimer *et al.* (1966)
- (e) Kleber *et al.* (1963)
- (f) Harris *et al.* (1951)
- (g) Harris *et al.* (1954)

these compounds will be modified during mashing and may undergo further changes during wort boiling. Whole hops and pellets will also contain small amounts of these nitrogenous products.

9.3.2 Proteins

Proteins are macromolecules which may be classified according to their solubility, size and charge (molecular weight and isoelectric point), or function, i.e. storage proteins, structural proteins, and proteins that bind other molecules: hormones, immunoproteins, carrier proteins and enzymes. The backbone of all proteins is the polypeptide chain built up of amino acid residues which is partially broken down by enzymes during mashing. However, after the enzymes are deactivated, further cleavage of the polypeptide chain during wort boiling is unlikely as several hours treatment with 6N-hydrochloric acid at 100°C is necessary for complete hydrolysis of proteins and peptides. The primary structure of a protein is the sequence of amino acids in the polypeptide chain. These amino acids (Fig. 4.24) contain other functional groups which can interact to stabilize the three-dimensional 'tertiary' structure of the protein necessary for its biological activity. Of these cross-linking reactions, the formation of covalent disulphide bridges is very important. Oxidation of the thiol, -SH, group in cysteine residues gives a disulphide bridge, -S-S-, as in cystine residues. This reaction is reversible depending on the redox status of the system. In contrast, the formation of a covalent link between two phenolic tyrosyl residues is not readily reversible. Aspartic and glutamic acid residues in a polypeptide chain have a free carboxylic acid group (pKa c. 3.5) which can form salts (ionic bonds) with basic groups found in the side chains of lysine (pKa c. 10), arginine (pKa 12–13), or histidine (pKa 5.5–7.5).

Hydrogen bonds are also important; hydrogen bonds between the $>C=O$ and the -NH- of the peptide bonds can lead to 'secondary' structures such as the α -helix and the β -pleated sheet. Hydroxyl groups in serine and tyrosine can also form hydrogen bonds, and hydrogen bonds with water will aid the solubility of proteins. In contrast, the side chains of valine, leucine, isoleucine and phenylalanine will produce hydrophobic areas in the protein structure; such areas may be in the core of the protein structure. Proteins denature on heating, examples are curdled milk and boiled eggs. As the temperature rises increasing violent thermal motion disrupts the tertiary structure of the protein, necessary for enzyme activity, and hydrophobic groups will come to the surface of the structure. Here they may interact with other hydrophobic groups to reduce the solubility of the protein and it coagulates. In wort, the protein is precipitated as the hot break or trub.

The removal of some high molecular weight protein is one of the objects of wort boiling. Insufficient coagulation and the removal of such proteins may effect exchange processes between yeast cells and the surrounding medium (membrane blocking) leading to an insufficient pH drop in the fermentation. The excess protein may not then be eliminated during the fermentation and lead to clarification problems and harsh bitterness in the final beer. Further, proteins surviving into the final beer may react, on storage, with polyphenols to form a non-biological haze which will shorten the shelf-life of the beer. Nevertheless, some proteins are necessary in beer to produce acceptable head retention and mouth-feel.

The coagulation of proteins is strongly influenced by the pH of the wort and is most successful at the isoelectric point of the individual proteins, when the number of positive and negative charges is equal. During wort boiling the pH will drop by 0.1–0.2 pH units

to about 5.0. This may be due to the addition of hop bitter acids, the formation of acidic Maillard products (see later), the precipitation of alkaline phosphates

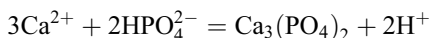

or the reaction of polypeptides with calcium, liberating protons. It is found that above pH 5.0 the amount of nitrogen precipitated during a two-hour boil is fairly constant but less is precipitated from more acidic solutions. The amount of hot break formed also depends on the length and vigour of the boil. Even after boiling for three hours more nitrogen is precipitated if the boil is continued for a further three hours. Miedaner (1986) gives the level of coagulable nitrogen in unboiled wort as 35–70 ppm which is reduced to 15–25 ppm after boiling with a recommended level of 15–18 ppm. However, the measurement of coagulable nitrogen is difficult. It is usually measured as the difference between the total soluble nitrogen (TSN), determined by Kjeldahl analysis of an aliquot of the hot water extract, and the permanently soluble nitrogen (PSN), remaining after boiling. It is this last analysis which is not very reproducible.

Worts held at 98–100 °C without boiling or agitation remain turbid which explains the importance of the vigour of the boil. The intensity of wort circulation depends on copper design (Chapter 10) and evaporation rate. In classical wort boiling at atmospheric pressure, evaporation of 8–10% of the wort volume/h was recommended, i.e., up to 20% of the wort volume over two hours. This requires a lot of expensive energy and to-day modern kettles operate with a 60 min. boil with 5–8% evaporation (O'Rourke, 1999). Reed and Jordan (1991) claim that evaporation in excess of 2–3% can be replaced by suitable agitation. In their laboratory apparatus the fastest clarification was found with stirring at 125 rpm. Insufficient or excessive agitation increases clarification time. It is the increase in floc size that is responsible for rapid sedimentation and excess agitation will have a shearing effect on the flocs. The hot break or trub is largely composed of protein. It was long thought that polyphenols were also involved but protein/polyphenol complexes, based on hydrogen bonds, are not stable at 100 °C. However, protein/polyphenol complexes become increasingly stable below 80 °C and are found in the cold break, but this accounts for only 2.5% of the material precipitated (Crompton and Hegarty, 1991).

Proteins can be separated according to molecular size by elution from Sephadex gels. These experiments (Table 9.2) suggest that more high-molecular weight compounds are precipitated during wort boiling than smaller molecules. Nevertheless, some malt proteins survive into beer (Sections 4.5.1 and 19.1.5). Proteolysis during mashing produces a range of amino acids (Table 9.3). Whole hops and pellets will add small amounts of these compounds during wort boiling. Small amounts of nitrogen may be lost as volatile compounds during wort boiling and some may be incorporated into melanoidins but the amino acid spectrum of sweet and boiled wort is very similar. The amino acid spectrum of beer is very different as many of these compounds are taken up as yeast nutrients during fermentation.

Table 9.2 Effect of boiling on the MW distribution of wort proteins (Guenther and Stutler, 1965)

Mol. Wt	< 5000	5–10,000	10–50,000	50–100,000	> 100,000
Boiled for 95 min.	0.0175	0.0125	0.0040	0.0010	0
Not boiled	0.0336	0.0185	0.0101	0.0023	0.0028

Table 9.3 Free amino acids in wort and beer (mg/100 ml) (Sandegren *et al.*, 1954)

Nitrogen and amino acids	Wort	Hopped wort	Beer	Beer refermented
Total nitrogen	88.0	84.8	62.6	47.0
Low molecular nitrogen alcohol soluble	63.4	69.5	50.7	35.1
Total α -amino nitrogen	42.7	38.0	21.0	13.0
Alcohol soluble α -amino nitrogen	37.6	30.8	18.2	2.5
Alanine	9.8	10.2	7.7	1.8
γ -Amino butyric acid	8.3	7.9	9.6	2.5
Arginine	13.8	5.9	3.0	0.6
Aspartic acid	7.0	9.8	1.6	1.0
Glutamic acid	6.4	3.3	0.8	0.7
Glycine	2.3	2.6	2.1	1.3
Histidine	5.7	3.8	2.8	0.2
Isoleucine	6.2	6.5	2.1	0.3
Leucine	18.1	17.5	4.7	0.7
Lysine	14.9	10.7	2.2	0.5
Phenylalanine	13.7	14.0	4.4	0.6
Proline (imino acid)	45.7	48.3	31.8	33.3
Threonine	5.9	7.3	0.3	0.3
Tyrosine	10.6	9.3	5.9	1.1
Valine	11.9	16.0	6.8	0.4
Serine + Asparagine mM in 100 ml	168.6	171.8	7.9	5.6
Ammonia	2.4	2.4	1.7	1.0

9.4 Carbohydrate-nitrogenous constituent interactions

Sweet wort boiled with or without hops increases in colour. This is due to ‘non-enzymatic browning’, a reaction between amines, or amino acids, and carbonyl compounds, especially reducing sugars. It is often named after its discoverer Louis-Camille Maillard (Ikan, 1996, Fayle and Gerrard, 2002). The pigments formed by non-enzymatic browning are called melanoidins and the ultimate product is caramel. Non-enzymatic browning should be distinguished from the action of polyphenoloxidase on substrates such as tyrosine, which produces the brown or black hair and skin pigments called melanins.

In the brewing process the Maillard reaction occurs when malt is kilned and continues during wort boiling. Obviously, dark and crystal malts will contain more melanoidins than pale ale or lager malts. It was estimated for an American beer (presumably pale) that about one-third of the colour was formed during kilning and the other two-thirds during wort boiling but the ratio will be different using dark malts. In addition to these pigments the Maillard reaction produces many volatile compounds, some of which have very low flavour thresholds and can influence the flavour of beer. As well as aliphatic compounds, oxygen, nitrogen and sulphur heterocyclic compounds are formed (Mottram, 1994).

There are many reviews of the Maillard reaction (Hodge, 1953; Reynolds, 1963, 1965; Nursten, 1980; Waller and Feather, 1983; Parliment *et al.*, 1994; Ikan, 1996; and Fayle and Gerrard, 2002). The basic chemistry is shown in Fig. 9.1. The amine, or amino acid, adds to the reducing group of the reducing sugar, in the aldehyde form (9.1), to give a product which is dehydrated to a Schiff's base (9.2). This rearranges to an Amadori compound (an *N*-substituted 1-amino-1-deoxy-2-ketose, (9.3) in the keto form, (9.4) in the enol form). Amadori compounds characterized in malt include those from: Fru-Ala, Fru-Gly, Fru-Val, Fru-Leu, Fru-Ile, Fru-Ser, Fru-Thr, Fru-Pyr, Fru-Asp, Fru-Glu, Fru- γ -aminobutyric acid, and Fru-Pro (Eichner *et al.*, 1994). Fru-Pyr, fructose-pyrrolidonecarboxylic acid, is formed

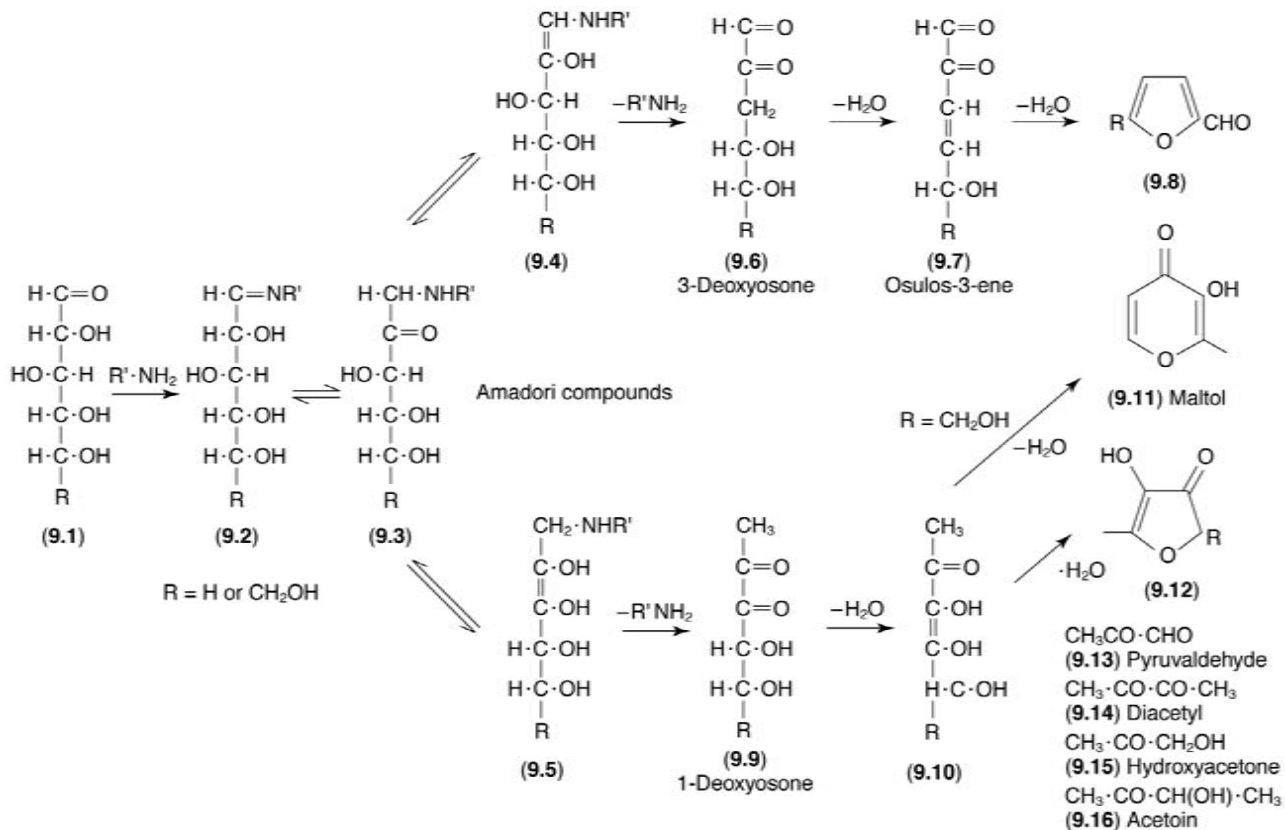

Fig. 9.1 The chemistry of non-enzymatic browning.

from Fru-Glu and Fru-Glutamine during work up. Dark malts contain higher concentrations of Amadori products but they cannot be found in malts heated above 200 °C. Considerable degradation of Amadori products occurs during mashing and wort boiling, but apparently not during fermentation, and some products survive into beer. Amadori compounds can decompose by two routes: 1,2-enolization occurs at low pH values and 2,3-enolization at higher pH values. Eichner *et al.*, (1994) studied the model system Fru-Gly during two hours in a citrate buffer solution (pH 3.0) at 90 °C and found that the major decomposition was via 3-deoxyglucosone (**9.6**, $R = CH_2OH$) to 5-hydroxymethylfurfural (HMF, **9.8**, $R = CH_2OH$). The proportion of 3-deoxyglucosone reaches a maximum after 15 h after which no more accumulates (formation = decomposition) but the concentration of HMF continues to increase throughout the reaction. Indeed, the level of HMF can be used to follow the Maillard reaction.

In beer a correlation between the stale flavour and the HMF content has been reported (Shimizu *et al.*, 2001). Increased, and possibly unacceptable, levels of HMF and other Maillard products are formed during high temperature wort boiling (Fig. 9.2). It is recommended (Miedaner, 1986) that the temperature should not exceed 140 °C and the holding time should not exceed 2.5 min. at 140 °C and 3 min. at 130 °C. In the same way pentose sugars will produce furfural (**9.8**, $R = H$, **9.17**). Related heterocyclic compounds found in roasted barley (Harding *et al.*, 1978), malt (Tressl *et al.*, 1977) and beer (Harding *et al.*, 1977; Tressl *et al.*, 1977) are shown in Fig. 9.3–9.7 and in Tables 9.4 and 9.5. The level of 2-acetylfuran (**9.25**), 2-acetylthiophene (**9.27**), furfuryl alcohol (**9.20**), 5-methylfurfural (**9.22**), and 5-methylthiophenecarboxaldehyde (**9.24**) is higher in ales than in lagers probably due to the higher kilning temperatures used in the preparation of the malts. Compared to pale ale malt, crystal malt contains enhanced levels of most of the heterocyclic compounds discussed.

2,3-Enolization of Amadori products gives rise to 1-deoxyosones (**9.9**). With hexose sugars, e.g. (**9.9**, $R = CH_2OH$), dehydration can give maltol (3-hydroxy-2-methyl-4H-pyran-4-one, **9.11**), isomaltol (1-(3-hydroxy-2-furanyl)ethanone, **9.30**), and 2,5-dimethyl-4-hydroxy-3(2H)-furanone (furanol, **9.12**, $R = CH_3$). All these compounds have sweet caramel flavours and maltol (**9.11**) and furfuryl mercaptan (**9.29**) occur in beer above the flavour threshold concentrations. Compounds, such as **9.10**, which contain

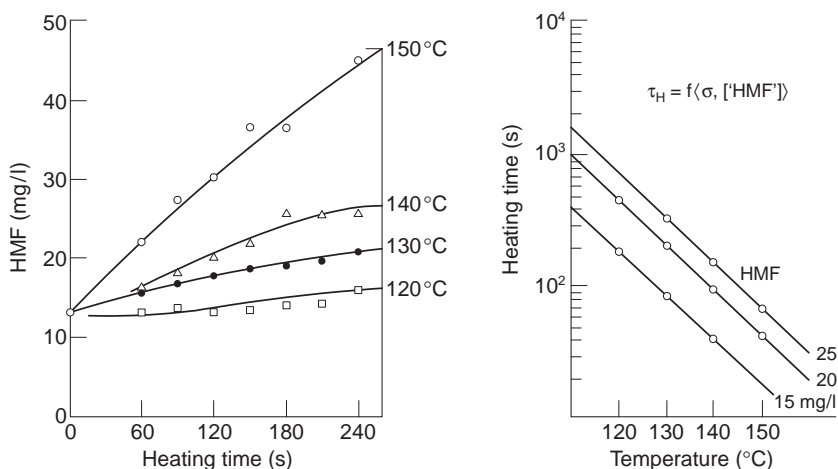

Fig. 9.2 Hydroxymethylfurfural production during high temperature boiling (Miedaner, 1986).

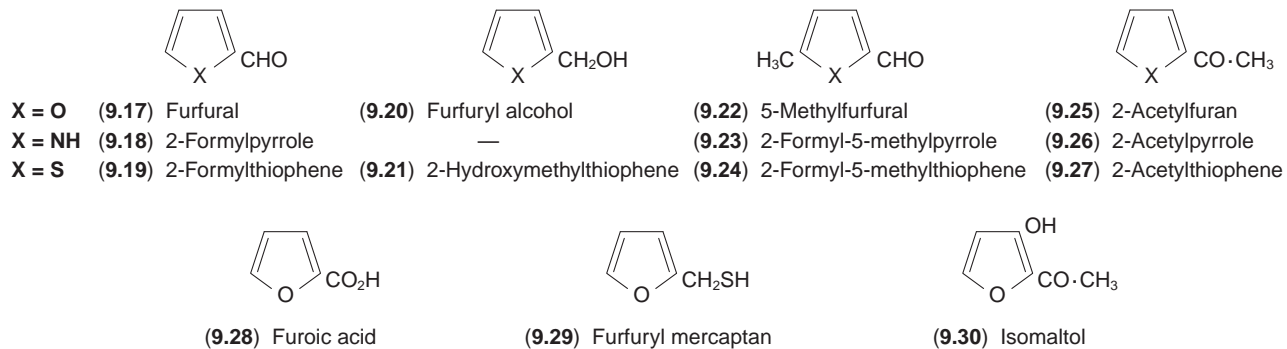

Fig. 9.3 Heterocyclic compounds in roasted barley, wort and beer.

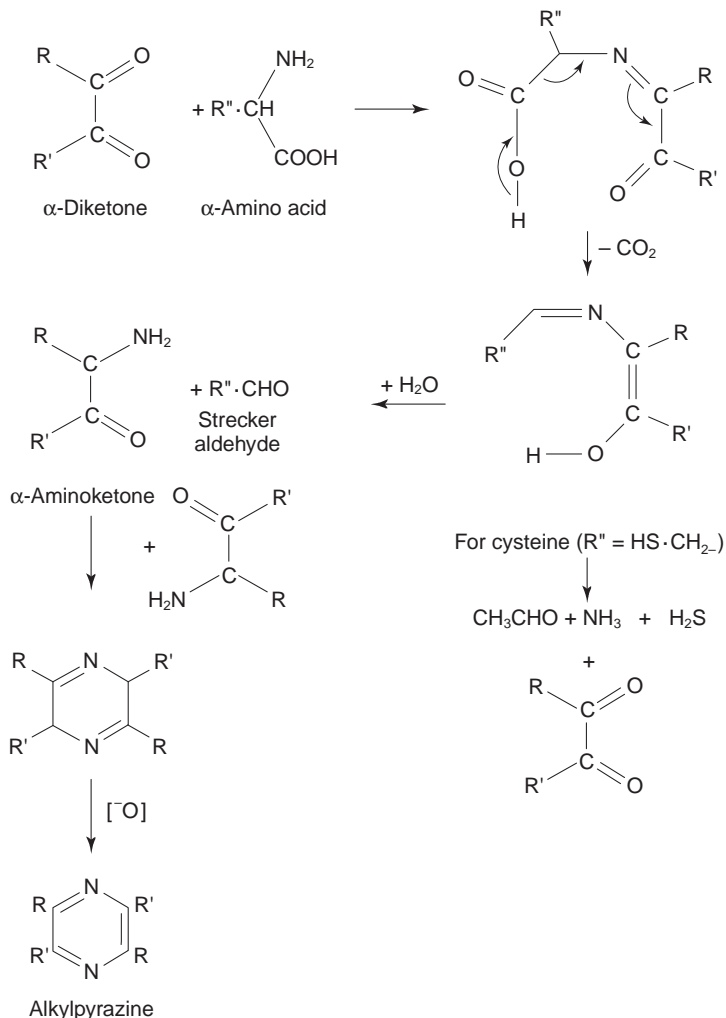

Fig. 9.4 Strecker reaction of α -amino acids and formation of alkyipyrazines.

the $-C(OH) = C(OH).C=O$ grouping are called reductones and combine with oxygen to maintain the oxidation/reduction (redox) balance of a system. Another example of a reductone is ascorbic acid (vitamin C). Fragmentation of the deoxyosone intermediates can lead to the α -dicarbonyl compounds, pyruvaldehyde (9.13) and 2,3-butanedione (diacetyl, 9.14) and the related ketols hydroxyacetone (9.15) 3-hydroxy-2-butanone (acetoin, 9.16).

The deoxyosones and other α -dicarbonyl compounds can react with amino acids according to the Strecker reaction (Fig. 9.4) to give aldehydes, with one carbon less than the amino acids, carbon dioxide, and an α -amino ketone. Most of the Strecker aldehydes (Table 9.6) have potent aromas but those that survive wort boiling are likely to be reduced to the corresponding alcohols during fermentation. The amino ketones formed in the Strecker reaction can condense together to form, after oxidation, pyrazines (9.34). The pyrazines found in roasted barley malt and beer are listed in Table 9.6. As illustrated in Fig. 9.4, the amino acid cysteine breaks down in the Strecker reaction to liberate

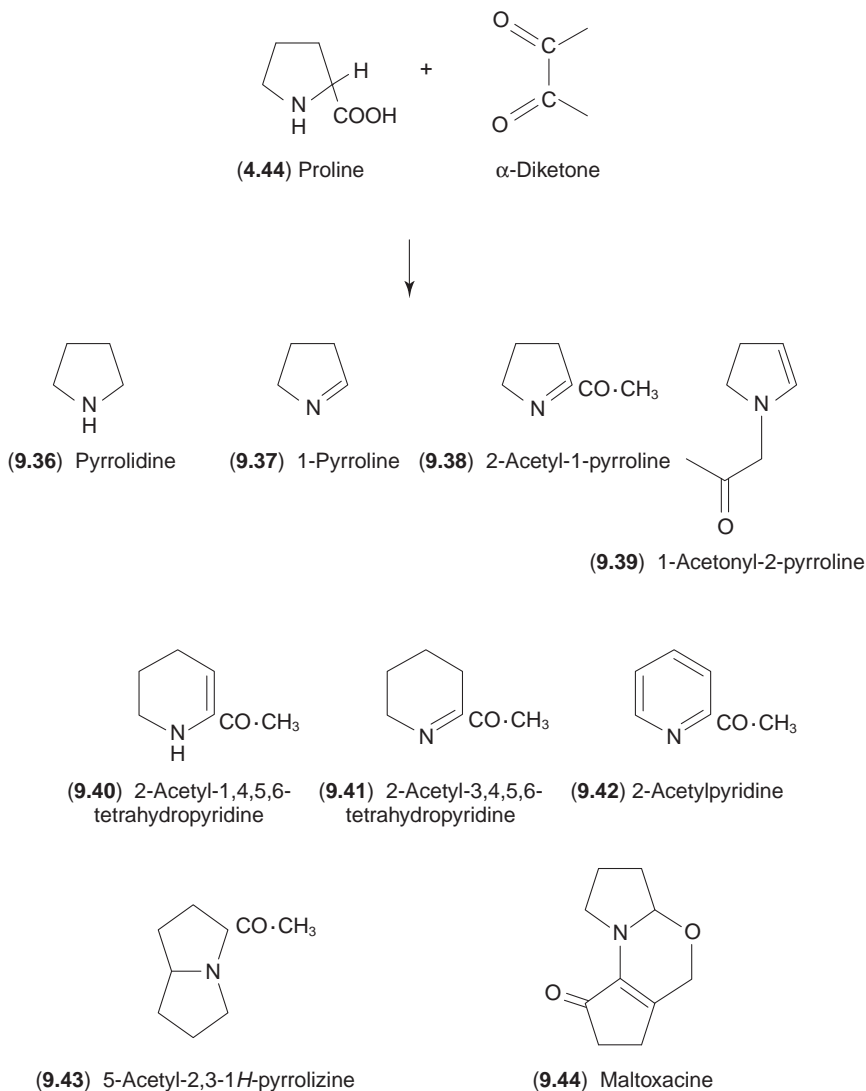

Fig. 9.5 Products of the Strecker reaction with proline.

hydrogen sulphide, which is probably incorporated into the sulphur heterocyclic compounds formed during wort boiling. The imino acid proline is not strictly an amino acid but is the major ‘amino acid’ in wort (Table 9.3). In the Strecker reaction it cannot form a Strecker aldehyde and an α -amino ketone but it reacts with α -dicarbonyl compounds to form nitrogen heterocyclic compounds such as 1-pyrroline (**9.37**), pyrrolidine (**9.36**), 1-acetyl-2-pyrroline (**9.39**), and 2-acetyl-1,4,5,6-tetrahydropyridine (**9.40**) (Fig. 9.5).

Roberts and Acree (1994) studied the Glu-Pro Maillard reaction by GC-Olfactometry. The seven most potent products, characterized by olfactometry, were: diacetyl (**9.14**, %‘Charm’, 0.5), 2-acetyl-1-pyrroline (**9.38**, 19), 2-acetyl-1,4,5,6-tetrahydropyridine (**9.40**, 12), 2-acetylpyridine (**9.42**, 19), 2-acetyl-3,4,5,6-tetrahydropyridine (**9.41**, 63), furaneol (**9.12**, **R** = **CH₃**, 3.9) and 5-acetyl-2,3-1H-pyrrolizine (**9.43**, 0.3). According to

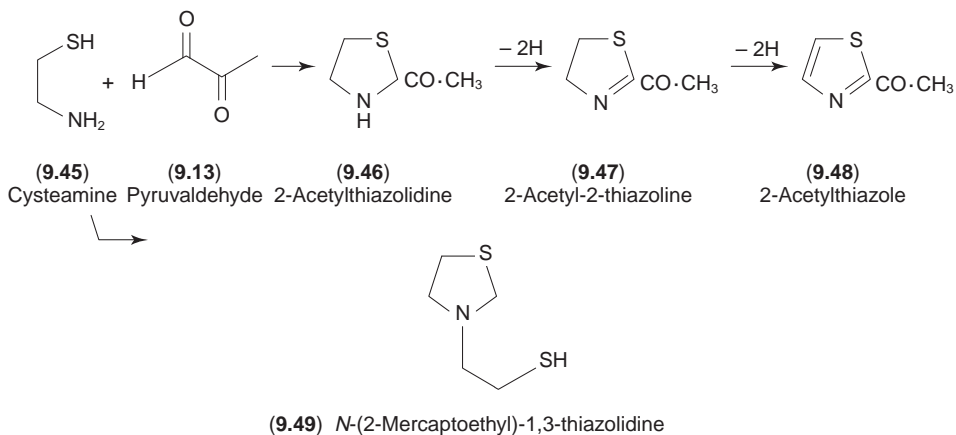

Fig. 9.6 Formation of thiazoles.

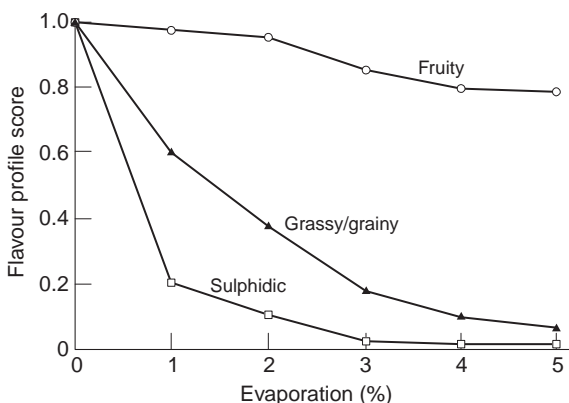

Fig. 9.7 Effect of evaporation on some important flavour characters (O'Rourke, 1999).

the mass yield this last compound was the major product of the reaction. Maltoxazine (9.44) was also formed in considerable amounts but had little or no aroma. Details of Maillard reactions between most of the amino acids (Table 9.3) and the common sugars can be found in the literature.

The presence of thiazoles in roasted barley, malt and beer is recorded in Table 9.4. Of particular interest is 2-acetyl-2-thiazoline (9.47) and 2-acetylthiazole (9.48) which have popcorn flavours with low thresholds. The former compound is thought to be formed (Fig. 9.6) by condensation of cysteamine (9.45) (formed by decarboxylation of cysteine) and 2-oxopropanal (9.13, pyruvaldehyde) to give 2-acetylthiazolidine (9.46) which, by dehydrogenation, gives (9.47) and probably (9.48). A Maillard reaction between cysteamine and fructose produces *N*-(2-mercaptoethyl)-1,3-thiazolidine (9.49) which has an intense popcorn-like odour with an extremely low threshold (0.005 ng/l in air) (Engel and Schieberle, 2002). Thiazoles may also be formed by degradation of thiamine (vitamin B₁, 4.68).

As well as these Maillard reaction products, malt and hops will contribute volatile compounds to wort which, if not partially removed, will lead to unacceptable beers. Normally the excess of these compounds is lost by evaporation during wort boiling. As

Table 9.4 Derivatives of pyrrole, thiazole and pyridine in roasted barley, malt and beer (see text for references)

		
(9.31) Pyrrole	(9.32) Thiazole	(9.33) Pyridine
Unsubstituted	Unsubstituted	Unsubstituted
2-Methyl	4-Methyl 5-Methyl Dimethyl	Methyl
1-Acetyl 2-Acetyl (9.26)	2-Acetyl	2-Acetyl 3-Acetyl
2-Formyl-1-methyl 2-Formyl-5-methyl 1-Ethyl-2-formyl 1-Furfuryl	5-Hydroxyethyl-4methyl	

Table 9.5 Pyrazines in roasted barley, malt and beer (for references see text)

	
(9.34) Pyrazine	(9.35) Cyclopentapyrazine
Pyrazine	Concentration (ppb)
	Malt Beer
1. Methylpyrazine	280 70
2. 2, 5-Dimethylpyrazine	130 110
3. 2, 6-Dimethylpyrazine	120 35
4. 2, 3-Dimethylpyrazine	200 15
5. Ethylpyrazine	140 10
6. 2-Ethyl-6-methylpyrazine	80 }35
7. 2-Ethyl-5-methylpyrazine	40 }
8. 2-Ethyl-3-methylpyrazine	80 +
9. Trimethylpyrazine	320 20
10. 2-Ethyl-3, 6-dimethylpyrazine	10 20
11. 2-Ethyl-3, 5-dimethylpyrazine	30 10
12. 2-Ethyl-5, 6-dimethylpyrazine	10 +
13. Tetramethylpyrazine	110 +
14. 6, 7-Dihydro-5 <i>H</i> -cyclopentapyrazine	+ 10
15. 5-Methyl-6, 7-dihydro-5 <i>H</i> -cyclopentapyrazine	20 15
16. 2-Methyl-6, 7-dihydro-5 <i>H</i> -cyclopentapyrazine	20 10
17. 5-Methylcyclopentapyrazine	10 +
18. 2-Furfurylpyrazine	+ 25
19. 2-(2'-Furfuryl)methylpyrazine	- 10
20. 2-(2'-Furfuryl)dimethylpyrazine	- +

+ Detected but not quantified

- Not detected

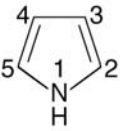
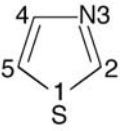
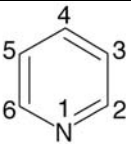
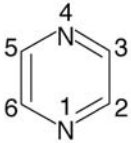
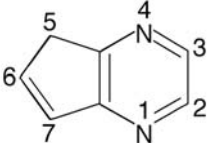
Table 9.6 Aldehydes produced in the Strecker reaction (after Ho, 1996)

Amino acid	Aldehyde	Odour properties	Flavour threshold (ppm) ^a
Alanine	Acetaldehyde CH ₃ CHO	Pungent, ethereal, green, sweet	10
Valine	Isobutyraldehyde (CH ₃) ₂ CH.CHO	Extremely diffusive, pungent, green, in extreme dilution almost pleasant, fruity, banana-like	(1.0)
Leucine	Isovaleraldehyde (CH ₃) ₂ CH.CH ₂ CHO	Very powerful acrid-pungent. In extreme dilution fruity, rather pleasant	(0.6)
Isoleucine	2-Methylbutanal CH ₃ CH ₂ CH(CH ₃)CHO	Powerful, but in extreme dilution almost fruity – ‘fermented’ with a peculiar note resembling that of roasted cocoa or coffee	1.25
Methionine	Methional CH ₃ S.CH ₂ CH ₂ CHO	Powerful onion-meat-like, potato-like	(0.25)
Phenylalanine	Phenylacetaldehyde C ₆ H ₅ CH ₂ CHO	Very powerful, pungent, floral and sweet	(1.6)

^a Meilgaard, 1975

shown in Fig. 9.7 grassy/grainy and sulphidic aromas are greatly reduced with only 2% evaporation. An important malt-derived volatile is dimethyl sulphide (DMS, **4.112**), the flavour threshold of which is 40–60 ppb but some all-malt lagers with 100 ppb DMS are found acceptable. Above this level DMS gives a sweetcorn flavour. DMS is produced by thermal decomposition of *S*-methylmethionine (Fig. 4.34), the half-life of which is reported to be 35 min. at 100 °C. DMS formed by kilning and wort boiling will be rapidly lost by evaporation but *S*-methylmethionine will continue to break down during wort cooling and the DMS formed then will persist into beer. To minimize such DMS formation it is recommended (O’Rourke, 1999, 2002) to use malts with low *S*-methylmethionine contents and to extend the wort boiling time to decompose the majority of the precursor and drive off the DMS. Worts from high-temperature wort boiling systems contain negligible amounts of DMS and its precursors. It is also recommended to minimize the whirlpool stand time and to use quick wort cooling to reduce the time that the wort is held hot.

When wort is boiled with whole hops or pellets, the majority of the hop oil constituents will be lost during a 60–90 min. boil in an open copper. If late hop character is required a portion (up to 20%) of the hop grist may be added, as choice aroma hops, 5–15 min. before the end of the boil. Early attempts at high temperature wort boiling, with insufficient venting, produced worts with unacceptable levels of hop oils. Excess Maillard volatile products must also be evaporated. Figure 9.8 shows the amounts of various heterocyclic compounds in the vapour condensate during wort boiling. Of particular interest is 2-acetylthiazole, which has a flavour threshold of 10 ppb in beer, and must be reduced if not to cause an off-flavour.

9.4.1 Melanoidins

The volatile products of the Maillard reaction have been studied in more detail than the melanoidin pigments. These are obviously heterogeneous depending on the sugars and amino acids involved, their ratios and the pH and temperature of the reaction (Ikan, 1996).

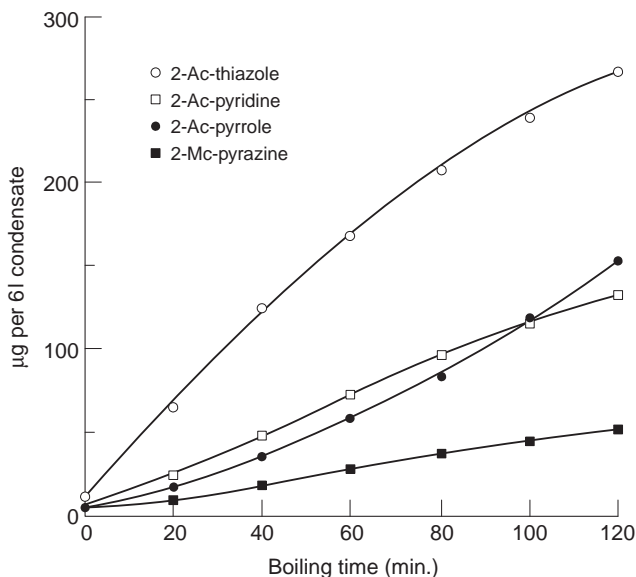

Fig. 9.8 *N*-Heterocyclic compounds in the evaporation condensate during wort boiling (Miedaner, 1986).

At neutral or slightly acidic pH, osones, furfurals, and probably other heterocyclic compounds are involved in the formation of melanoidins, which are high molecular weight compounds (10,000–30,000 daltons by ultracentrifugation; 20,000 by gel filtration). Isoelectric focusing electrophoresis of the melanoidins from a Glu-Gly reaction showed 20 bands while those from a Xyl-Gly reaction showed 16 bands. Spectroscopic studies of the products, with and without isotopic labelling, and ozonolysis has led to the suggestion that the melanoidins contain the repeating structure shown in Fig. 9.9. The melanoidins, which may resemble the humic acids in soil, show many interesting biological reactions which may influence the brewing process (Ikan, 1996). For example, they show antimicrobial activity, especially towards enteric bacteria; they inhibit trypsin and have dietary fibre-like action; they show mutagenic action; they react with metal ions and show antioxidative effects. In particular, melanoidins scavenge hydroxyl radicals, hydrogen peroxide and superoxides (Hayase, 1996) and have an influence on beer foam.

9.4.2 Caramel

The FAO/WHO and the EEC Scientific Committee for food have accepted four classes of caramel (Thornton, 1989):

Class I. Caramel prepared by the controlled heat treatment of carbohydrates with or without the presence of food quality alkali or acid.

Class II. Caramel prepared by the controlled heat treatment of carbohydrates with caustic sulphites.

Class III. Caramel prepared by the controlled heat treatment of carbohydrates with ammonia.

Class IV. Caramel prepared by the controlled heat treatment of carbohydrates with ammonium and sulphite containing compounds.

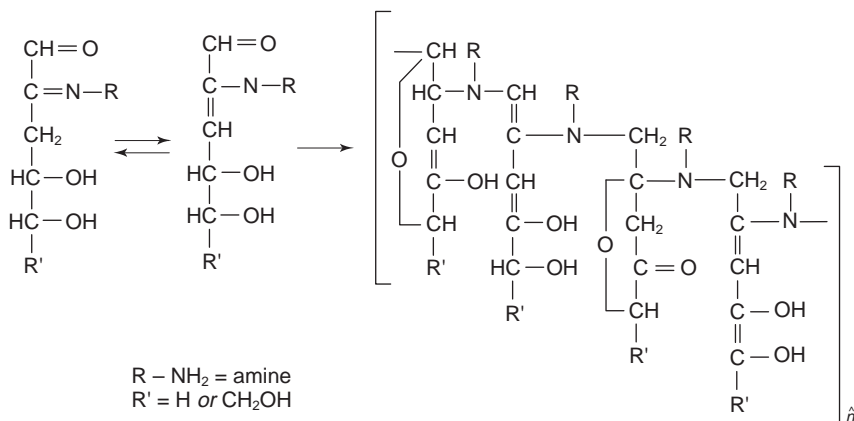

Fig. 9.9 Possible repeating units of melanoidins and their precursors (after Kato and Tsuchida, 1981).

Class I caramels are used in spirits and liqueurs, Class II caramels in vermouths and other aperitifs, and Class IV caramels in soft drinks. Class III caramels, ammonia caramels, are used in bakery and meat products and in brewing. Ammonia caramel (E 150 (c)) is used for colouring/colour adjustment of beer and is the only colouring matter permitted in beer in the UK. These electropositive caramels are prepared from glucose syrups, with high dextrose equivalents, and 0.880 ammonia. They are allowed to react together for at least a week at ambient temperature, then at 90°C overnight, and finally at 120°C for about three hours. Heating must be carefully controlled to maintain a balance between colour and viscosity. At the appropriate time the mixture is cooled to 80°C, softened water added and the product blended as required.

The product contains about 25% extract and 32,000–48,000 EBC colour units (see Chapter 19). The UK Food Advisory Committee has recommended that there should be a limit for caramel in beer of 5000 mg/kg. Other committees have established an acceptable daily intake of ammonia caramel of 200 mg/kg bodyweight for man. The EEC specification states that not more than 50% of the colour should be bound by DEAE cellulose but more than 50% should be bound by phosphoryl cellulose. Caramel contains 0.7–3.3% total nitrogen but not more than 0.3% ammoniacal nitrogen and not more than 0.2% total sulphur. The EEC also proposes limits for two possible by-products of caramel production (Fig. 9.10): not more than 250 mg/kg of 4-methylimidazole (9.50) and not more than 10 mg/kg of 2-acetyl-4-tetrahydroxybutylimidazole (9.51). There are the usual limits for heavy metals, etc. Most commercial caramels will comply with these limits. Class IV electronegative caramels cannot be used in beer as they react with the electropositive finings. Caramel can be added to the copper but is usually added with primings to make minor adjustments to the colour of beer. However, the fundamental colour of beer will be determined by the choice of malt and adjuncts added to the copper.

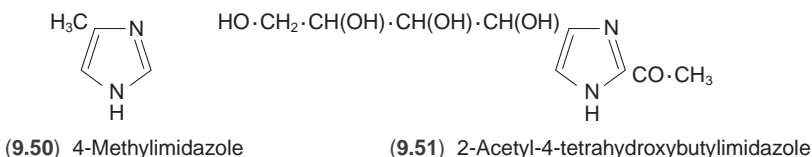

Fig. 9.10 Imidazoles limited in a caramel.

9.5 Protein-polyphenol (tannin) interactions

The polyphenols in malt (Section 4.4.9) and hops (Section 8.4) have been discussed earlier (see pp. 158–60; 302 for structures). The phenolic acids (hydroxybenzoic acids and hydroxycinnamic acids) and the hop flavonols (usually as glycosides) readily dissolve during mashing and wort boiling and most survive into beer. McMurrough and Delcour (1994) regard the flavanoids (proanthocyanidins) as the most important polyphenols in wort and classify them as: simple flavanols ((+)-catechin, (–)-epicatechin, dimeric and trimeric flavanoids); polymeric flavanols ('oxidation' products of the simple flavanoids, and complex flavanols (in water-soluble association with polypeptides).

Polyphenols form strong hydrogen bonds with polypeptides and these complexes are comparatively inert. As already mentioned they dissociate above 80 °C and the polypeptide can be displaced with urea, H₂N.CO.NH₂. They are non-tanning and their presence in beers does not necessarily lead to haze formation, even in beers stored in bottles with excessive headspace air. Simple flavanoids are very susceptible to free radical reactions initiated either by oxygen or plant oxidase/peroxidase enzymes. These reactions can lead to cross linking, an increase in molecular size, the formation of a red-brown colouration and the formation of polymeric flavanols which are strongly tanning. The tanning properties of the simple flavanoids increase with increases in the molecular weight.

Wort boiling causes a big change in its phenolic make-up. In sweet wort the dimeric flavanols (prodelphinidin B₃ and procyanidin B₃, 18 mg/l) and (+)-catechin (6 mg/l) predominate. After boiling with hops the level of dimeric and trimeric flavanols falls (to 6 and 5 mg/l respectively) while that of (+)-catechin and (–)-epicatechin increases (to 10 mg/l). The (–)-epicatechin is derived not only from hops but also by epimerization of (+)-catechin. Derdelinckx and Jerumanis (1987) also showed that proanthocyanidins depolymerize during brewing. McMurrough and Delacour (1994) conclude that it is the simple flavanols that are the haze precursors in wort.

Similarly, Whittle *et al.* (1999) studied the polyphenols in barley and beer. They identified over 50 flavanols in barley, including seven pentamers, but in beer only 24 flavanols were found including (+)-catechin and (–)-epicatechin. No tetramers and pentamers survived into beer but it was not established whether they were destroyed in mashing or in wort boiling. However, these flavanols do not appear to be necessary for protein coagulation. Beers were made with a proanthocyanidin-free malt (Galant) and a regular malt (Triumph) and bittered either with Saaz hops or a tannin-free hexane extract. All four brews showed similar levels of coagulatable nitrogen after a 60 minute boil. After a longer boil (90 min.) the coagulatable nitrogen was reduced further in every case (Delacour *et al.*, 1988). Techniques to remove protein-polyphenol complexes from beer are discussed in Chapter 15.

9.6 Copper finings and trub formation

The importance of removing some of the protein from sweet wort and the difficulties that can arise later if this is not accomplished have been mentioned and is discussed further in Chapter 15. With a view to improving trub formation many brewers add electronegative finings to the copper at or near the end of the boil (4–8 g/hl). These copper finings are usually Irish moss, the dried red marine algae *Chondrus crispus* (plus some *Gigartina stellata*) or the purified polysaccharide therefrom, κ-(kappa)-carrageenan. This

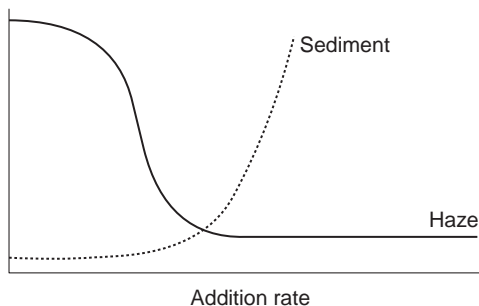

Fig. 9.11 The effect of copper fining rate on performance (Leather, 1998).

polysaccharide is made up of a chain of galactose and occasionally anhydrogalactose, units linked alternately 1–3 and 1–4. Some of the free hydroxyl groups are esterified with sulphate groups providing the negative charge. Instead of Irish moss, some brewers add silica gel. These copper finings should be distinguished from the proteinaceous isinglass finings used to clarify beer either in cask or conditioning tank (Chapter 15). Nevertheless, the use of copper finings reduces the non-microbiological particles (NMP) in the final beer (Leather *et al.*, 1996).

Under optimum boiling conditions, e.g., a vigorous rolling boil under atmospheric pressure at 102 °C for at least an hour, the hot break is formed as large flocs which can be removed in the hop back or whirlpool. When the wort is boiled with whole hops or pellets the trub adheres to the hop debris. In contrast, with inefficient wort boiling, or in a plant producing excessive shear, the trub may separate as fine flocs, which remain in suspension. Similarly, the cold break consists of very fine particles that are slow to form and settle and consequently may survive fermentation and be carried over into the beer (Chapter 10). Leather (1998) lists eleven factors which affect copper fining performance. As the dose rate increases, wort clarity improves and the amount of sediment also increases (Fig. 9.11). The optimum fining rate is that which produces the best wort clarity with the minimum volume of sediment. In practice this produces a beer containing approximately 10^6 non-microbiological particles/ml in each of the three size fractions, $< 2 \mu\text{m}$, $2\text{--}10 \mu\text{m}$, and $> 10 \mu\text{m}$. The optimum fining rate is found by experiment. Wort clarity is assessed on an arbitrary scale from A (brilliant) to F (cloudy) or can be measured by the absorbance at 600 nm against a membrane filtered wort.

Copper finings have no significant effect on hot wort clarity, their main effect being the production of bright cold wort. They are added to hot wort since κ -carrageenan does

Table 9.7 Typical composition of hot and cold break (Moll and de Blauwe, 1994)

	Hot break	Cold break
Particle size mm	30–80	0.5–1.0
Typical wet weight g/hl	150–400	5–30
Moisture %	73–85	70–80
Proteinaceous matter degree	40–70	45–75
Bittering substances %	10–20	n/a
Polyphenols %	5–10	10–30
Carbohydrates %	4–8	20–30
Ash %	3–5	2–3
Fats %	1–2	n/a

not dissolve below 60 °C. The copper finings should be added early enough in the boil so that they all dissolve but late enough so that they are not significantly degraded. For the same reason long stands in the whirlpool should be avoided. A wort of pH of c. 5.0 is required for efficient fining and worts below pH 4.5 often fail to fine. A difference of 0.3 pH units can make a difference between optimum (A) clarity and poor (D) clarity. Malt variety and quality also influences copper fining performance. As well as the influence malt has on the pH of the wort, the amount of cold break protein (the amount of cold break that forms naturally without the addition of copper finings) correlates positively with copper fining performance.

Analyses of hot and cold break are given in Table 9.7. It will be noted that in terms of mass the cold break is less than 20% of the hot break and that both are largely made up of proteinaceous materials. The cold break is richer in polyphenols and carbohydrates. Although hydrogen bonds between polyphenols and polypeptides are largely dissociated above 80 °C, some malt and hop polyphenols are precipitated with the hot break but, according to McMurrough and Delacour (1994), 'their role is more passive than active'. Ninety per cent of the lipids in the copper are deposited with the trub and spent hops (Anness and Reed, 1985). In addition some fatty acids may be lost by steam volatilization; with 12% evaporation 0.9% of the lipids in wort were lost by this route.

9.7 References

- ANNES, B. J. and REED, R. J. R. (1985) *J. Inst. Brewing*, **91**, 82.
- CROMPTON, I. E. and HEGARTY, P. K. (1991) *Proc. 23rd Congr. Eur. Brew. Conv., Lisbon*, p. 625.
- DELCOUR, J. A., VANHAMEL, S., MOERMAN, E. and VANCRAENENBROECK, R. (1988) *J. Inst. Brewing*, **96**, 371.
- DENK, V., FELGENTRAEGER, H. G. W., FLAD, W., LENEOL, M., MICHEL, R., MIEDANER, H., STIPPLER, K., HENSEL, H., NARZISS, L. and O'ROURKE, T. (2000) *European Brewery Convention – Manual of Good Practice, Wort Boiling and Clarification*, pp. xvi + 176. Fachverlag Hans Carl, Nürnberg.
- DERDELINCKX, G. and JERUMANIS, J. (1987) *Proc. 21st Congr. Eur. Brew. Conv., Madrid*, p. 577.
- EICHNER, K., REUTTER, M. and WITTMANN, R. (1994) in Parliment, T. H., Morello, M. J. and McGorin, R. J. (eds) *Thermally Generated Flavors – Maillard, Microwave and Extrusion Processes*. ACS Symposium Series No. 543, American Chemical Society, Washington DC, p. 42.
- ENGEL, W. and SCHIEBERLE, P. (2002) *J. Agric. Food Chem.*, **50**, 5391.
- EUROPEAN BREWERY CONVENTION See Denk *et al.*
- FAYLE, S. E. and GERRARD, J. A. (2002) *The Maillard Reaction*, Royal Society of Chemistry, London, xiv + 120 pp.
- GJERTSEN, P. (1953) *J. Inst. Brewing*, **59**, 296.
- GJERTSEN, P. (1955) *Proc. 5th Congr. Eur. Brew. Conv., Baden-Baden*, p. 37.
- GUENTHER, K. R. and STUTLER, J. R. (1965) *Proc. Annu. Meet. Amer. Soc. Brew. Chem.*, p. 30.
- HARDING, R. J., NURSTEN, H. E. and WREN, J. J. (1977) *J. Sci. Food Agric.*, **28**, 225.
- HARDING, R. J., WREN, J. J. and NURSTEN, H. E. (1978) *J. Inst. Brewing*, **84**, 31.
- HARRIS, G., BARTON-WRIGHT, E. C. and CURTIS, N. (1951) *J. Inst. Brewing*, **57**, 264.
- HARRIS, G., HALL, R. D. and MACWILLIAM, I. C. (1954) *J. Inst. Brewing*, **60**, 464.
- HAYASE, F. (1996) in Ikan, R. (ed.) *The Maillard Reaction*. John Wiley, Chichester, p. 89.
- HO, C.-T. (1996) in Ikan, R. (ed.) *The Maillard Reaction*. John Wiley, Chichester, p. 27.
- HODGE, J. E. (1953) *J. Agric. Food Chem.*, **1**, 928.
- IKAN, R. (1996) *The Maillard Reaction*. John Wiley, Chichester, p. 228.
- KATO, H. and TSUCHIDA, H. (1981) *Prog. Food Nutr. Sci.*, **5**, 147.
- KLEBER, W., SCHMID, P. and SEYFARTH, I. (1963) *Brauwissenschaft*, **16**, 1.
- LATIMER, R. A., LAKSHMINARAYANAN, K., QUITTENTON, R. C. and DENNIS, G. E. (1966) *Proc. Conv. Inst. Brew. Australian Section*, p. 111.
- LEATHER, R. V. (1998) *J. Inst. Brewing*, **104**, 9.
- LEATHER, R. V., WARD, I. L., MORSON, B. T. and DALE, C. J. (1996), *Ferment*, **9**, 31.
- McFARLANE, W. D. and HELD, H. R. (1953) *Proc. 4th Congr. Eur. Brew. Conv., Nice*, p. 110.
- McMURROUGH, I. and DELCOUR, J. A. (1994) *Ferment*, **7**, 175.
- MACWILLIAM, I. C. (1968) *J. Inst. Brewing*, **74**, 38.
- MEILGAARD, M. C. (1975) *Tech. Quart. MBAA*, **12**, 151.

- MIEDANER, H. (1986) *J. Inst. Brewing*, **92**, 330.
- MOLL, M. and DE BLAUWE, J. J. (1994) *Beers and Coolers*, (trans. by Wainwright, T.), Intercept, Andover. 495 pp.
- MOTTRAM, D. S. (1994) in Parliment, T. H., Morello, M. J. and McGorrrin, R. J. *Thermally Generated Flavors – Maillard, Microwave and Extrusion Processes*. ACS Symposium Series No. 543. American Chemical Society, Washington DC, p. 104.
- NURSTEN, H. E. (1980) *Food Chem.*, **6**, 263.
- O'ROURKE, T. (1999) *Brewers Guardian*, **128 (8)**, 34; **128 (9)**, 38.
- O'ROURKE, T. (2002) *The Brewer International*, **2 (2)**, 17.
- PARLIMENT, T. H., MORELLO, M. J. and MCGORRRIN, R. J. (eds) (1994) *Thermally Generated Flavors – Maillard, Microwave and Extrusion Processes*. ACS Symposium Series No. 543. American Chemical Society, Washington DC, pp. x + 492.
- REED, R. J. R. and JORDAN, G. (1991) *Proc. 23rd Congr. Eur. Brew. Conv., Lisbon*, p. 673.
- REYNOLDS, T. M. (1963) *Advances in Food Research*, **12**, 1.
- REYNOLDS, T. M. (1965) *Advances in Food Research*, **14**, 167.
- ROBERTS, D. D. and ACREE, T. E. (1994) in Parliment, T. H., Morello, M. J. and McGorrrin, R. J. *Thermally Generated Flavors – Maillard, Microwave and Extrusion Processes*. ACS Symposium Series No. 543. American Chemical Society, Washington DC, p. 71.
- SANDEGREN, E., ENEBO, L., GUTHENBERG, H. and LJUNGDAHL, L. (1954) *Proc. Annu. Meet. Amer. Soc. Brew. Chem.*, p. 63.
- SHIMIZU, C., NAKAMURA, Y., MIYAL, K., ARAKI, K., TAKASHIO, W. and SHINOTSUKA, K. (2001) *J. Amer. Soc. Brew. Chem.*, **49**, 51.
- THORNTON, J. (1989) *Brewing and Distilling International*, **20 (10)**, 36.
- TRESSL, R., RENNER, R., KOSSA, T. and KOPPLER, H. (1977) *Proc. 16th Congr. Eur. Brew. Conv., Amsterdam*, p. 693.
- WALLER, G. R. and FEATHER, M. S. (1983) *The Maillard Reaction in Food and Nutrition*. ACS Symposium Series No. 215. American Chemical Society, Washington DC.
- WHITTLE, N., ELDRIDGE, H., BARTLEY, J. and ORGAN, G. (1999) *J. Inst. Brewing*, **105**, 89.

10

Wort boiling, clarification, cooling and aeration

10.1 Introduction

Sweet wort is boiled with hops in a copper (kettle, hop-boiler). Sometimes, if the copper is not immediately available, the wort is held in an intermediate vessel, or underback, before it is boiled. It is held hot (75–80 °C; 167–176 °F) to minimize the risk of microbial infection. This ‘hold’ should not be prolonged as some thermophilic organisms, including some that can reduce nitrate ions to nitrite ions, can continue to grow and the wort will darken and its flavour will alter. A variety of hop preparations may be used instead of whole hop cones (Chapter 7), necessitating the use of different types of equipment to clarify the wort after the boil. The changes that occur during the boil are complex (Chapter 9) but at the end of the boil spent hops (whole cones or fragments) and flocks of precipitated material, the hot break or trub, should be suspended in a perfectly clear, or ‘bright’ wort, the colour of which will have increased during the boil. The trub and spent hops are separated from the wort, which is then cooled and aerated or oxygenated, usually while being transferred to a fermenter, where it is pitched (inoculated) with yeast.

For many years the hop-boil, which usually lasted for 1.5–2 h but sometimes longer, was regarded as a simple process, the only variations being the duration of the boiling period, the choice of hops, the hopping rate and whether the hops were added at the start of the boil, in the middle or near the end (late hopping, when aroma hops are added). However, the need to reduce the cost of boiling has resulted in the testing of different technologies for saving energy and the difficulties encountered have emphasized the complexity of the boiling process and the necessity of balancing the changes that occur.

There is a range of objectives to be met by boiling (Hough *et al.*, 1982; Miedaner and Narziss, 1986; Narziss, 1993). The first is to evaporate water and so concentrate the wort. Traditionally, an evaporation rate of 10% or more of the collected wort volume/h was usual. The cost of evaporating so much water is high, because the consumption of energy is high, and so it is now usual to minimize evaporation. The boil also removes unwanted volatile substances. Simply reducing the evaporation rate or shortening boiling times gives flavour and other problems, but newer designs of boilers reduce or eliminate this difficulty, by favouring the evaporation of the unwanted volatile substances, and boils of

60–90 min., with evaporation rates of as little as 4%/h can be used in appropriate equipment. The boil also sterilizes the wort, or at least destroys the ‘vegetative’ forms of microbes probably in the first 10–15 min. Spores may survive this process. From the boil onwards wort is handled under nearly aseptic conditions.

The changes that occur during boiling include the dispersion of the hop resins and oil, the isomerization of some of the α -acids, the conversion of dimethyl sulphide precursor (SMM; DMSP; **4.157**) to DMS (**4.158**), the formation of new flavour and aroma compounds, (largely through Maillard reactions, which also give rise to coloured compounds and so a darkening of the wort), the denaturation and inactivation of residual enzymes carried forward from the mash and the denaturation and coagulation of the proteins that, combined with polyphenols, form the trub (which may weigh 20–70 g dry wt./hl Chapter 9). The more vigorous and prolonged the boil the more complete the removal of coagulable proteins and the more resistant the beer to the formation of non-biological haze, but it will have less good foaming properties. The inactivation of the enzymes stabilizes the composition of the wort in one sense, but of course the high temperature maintains the on-going chemical reactions. The wort needs to be sufficiently agitated to cause the denatured proteins to coagulate and form flocks. This process may be assisted by the addition of copper finings, mainly the negatively charged, sulphated polysaccharide κ -carrageenan, ‘Irish moss’, added at 4–8 g/hl (Chapter 9). Instead some breweries use silica gel.

While vigorous mixing is essential, shear forces must be minimized to prevent the flocks being disrupted. Local ‘overheating’ at a heating surface should be avoided as the level of coagulable protein is unduly reduced and it can remove proteins that stabilize foam. Local overheating, as was common with older, direct-fired coppers, can also cause ‘burn-on’ and caramelization of wort sugars and copper adjuncts, which gives rise to (usually unwanted) flavours and cleaning difficulties with the copper. The boil is also used to ‘refine’ the flavour of the beer by evaporating unwanted volatile flavour and aroma compounds. These are more volatile than water and so, under the correct conditions, they can be evaporated to the desired extent at relatively low water evaporation rates. In the past it was often assumed that, during boiling, some oxidation of the wort by entrained air was desirable. The newer view is that this is not so, as oxidation darkens the wort, reduces flavour stability and favours haze formation in beers. The importance of oxidation varies with the type of beer being made.

Other substances, besides hop preparations and copper finings, that may be added to wort in the copper, include mineral or biologically prepared acids (for pH adjustment), salts, tannins, malt extracts, sugars and syrups. The addition of acids, such as lactic acid, reduces the pH of the wort as does the addition of calcium salts. Calcium ions, displacing hydrogen ions from phosphates and other molecules, giving salts that precipitate during boiling, reducing the pH by 0.1–0.2 units. The reduction of wort pH during the boil reduces the colour, gives beer with a ‘cleaner’ flavour, and a better ‘break’ formation, but hop utilization is reduced unless pre-isomerized preparations are used. Where zinc-deficiency may occur in the fermenters, small amounts of zinc chloride (0.1–0.2 mg/l) may be added to the wort. Gallotannins are sometimes added in calculated amounts to precipitate ‘haze-sensitive’ proteins with the trub, so stabilizing the beer. Other substances tested include active carbon, nylon powder, PVPP powder, kieselguhr and bentonite, but these are probably only rarely or never used in this way now.

In small-scale brewing malt extract may be dissolved to form wort, which is boiled with hops in the same operation. In larger-scale brewing sugars and syrups (copper adjuncts derived from cereals or starch and so differing in whether or not they contain

nitrogenous and other substances (Chapter 2)) may be added to increase the concentration of the wort and/or adjust its fermentability. The material must be added with care to ensure that it is dissolved and thoroughly dispersed in the wort. Failure can result in syrupy deposits settling onto the heating surfaces, where they are caramelized and burnt. Copper adjuncts are often used to increase the concentration of worts for use in high-gravity brewing. For example if one part of a syrup, SG 1150 (36.4°Plato) is added to nine parts of a wort of SG 1040 (10°Plato) the final, mixed wort will have an SG of about 1051 (12.6°Plato). Hop boiling is normally a batch process. Attempts have been made to develop continuous hop-boiling to allow all stages of beer production to run continuously, but only with limited success (e.g. Hall and Fricker, 1966; Hough *et al.*, 1982; see below).

10.2 The principles of heating wort

Early wort boilers were made of cast iron, but by the early 20th century most were made of copper. While copper has advantages (Table 10.1), more recently boilers have been made of stainless steel, but the vessels are still often called 'coppers'. Copper is easily worked, has a high thermal conductivity (approx. 380 W/m K at 100°C; 212°F) and vessels made from it have an attractive appearance (Hancock and Andrews, 1996; Royston, 1971; Wilkinson, 1991a). It can catalyse oxidative reactions, it increases wort colour during boiling and is said to remove sulphur-containing substances from wort, (perhaps by catalysing the oxidation of thiol groups), and so improves beer flavour. It also favours nucleate boiling because its surface is relatively wettable. Stainless steel, generally an austenitic grade such as 304 or 316, is less expensive but is not so easily worked, and so vessels are often of simpler shapes than those made of copper. It is more resistant to dilute acids or strongly caustic cleaning agents, such as 2–4% caustic soda, and because of its greater strength vessels made from it can be thinner (e.g. 1.6 mm) than those from copper, so its lower thermal conductivity (approx. 167 W/m K at 100°C; 212°F), is not very important at heat exchange surfaces. The lesser wettability of stainless steel does not favour nucleated boiling or tolerance of high heat flux densities, so the maximum temperatures used at heat exchange surfaces are lower than those which may be used with copper.

Early coppers were directly heated by wood or coal fires, and had calorific efficiencies of about 40–50%. Solid fuel heating is now rare, but some kettles are heated directly with gas or oil-fuelled flames, with calorific efficiencies of about 70%. The heated area must be covered by wort before heat is applied to prevent caramelization and charring. The fire or flames must be extinguished before the wort is withdrawn. Direct heating often imparts characteristic flavours to beers. As breweries became larger, some used many relatively

Table 10.1 Some properties of copper and stainless steel (Hough *et al.*, 1982)

Property	Copper	Stainless steel
Density (kg/m ³)	8930	7930
Specific heat (J/kg K)	385	510
Thermal conductivity (W/m K)	385	150
Yield stress (MN/m ²)	75	230
Heat flux (kW/m ²)	80*	60†

* For a conventional, jacketed kettle.

† For flat, stainless steel panels.

small coppers so that as wort was collected it could be boiled in the shortest possible time. This reduced the chances of microbial infection and the operation was flexible. When steam heating became established some breweries continued to use several small coppers to retain these advantages and even out the demand for steam, while others began to use one or two large coppers, which have lower capital and maintenance costs but have a large steam demand while the wort is being heated from its collection temperature to boiling. One advantage of pre-heating wort on its way to the copper is that this sudden steam demand is reduced. Some breweries use hot water, often at 145–170 °C (293–338 °F), to heat the coppers. To keep the water liquid (prevent it boiling) it is held under substantial pressure (around 17 bar). The hot water systems, which are expensive, need to be well insulated and need substantial outgoing and return pipework between the heat sink and the furnace(s). Because the water contains a substantial amount of heat sudden demands are more easily met than by steam. For heavily used, flat-sided coppers water heated systems have been preferred. Coppers have been boiled experimentally using microwave heating (Herrmann, 1999).

Steam is now the most usual heating agent in breweries. Steam, raised in a boiler house, is used dry and saturated at a relatively low pressure, about 4 bar, at about 148 °C (298 °F). (As the pressure is increased so is the boiling point of water and the temperature of the steam; Appendix A.11). At a heat exchange surface the steam condenses, giving up its latent heat which, in a copper, heats the wort. A sudden large demand for heat can cause the condensation of a great deal of steam and so a sudden drop in pressure which may cause vessels to collapse. Thus steam-heated systems must be fitted with pressure and vacuum release valves as well as condensate traps, pipes to return the condensed water to the boiler, strainers and pressure reducing valves. Delivering steam at a lower pressure reduces the temperature of a heating surface. Steam is used in a copper with 90–95% efficiency, but steam raising is less efficient and the overall efficiency is 65–70% (Hough *et al.*, 1982).

In modern installations wort is nearly always heated while flowing upwards in pipes mounted in steam jackets. The conduction of heat under ideal conditions, at a steady state, is described by Fourier's Law, $q = k A \Delta T / X$, where q is the rate of heat transmission, k is the thermal conductivity of the material, A is the cross-sectional area at right angles to the heat flow, ΔT is the temperature difference between the steam and the liquid to be heated and X is the thickness of the material across which the heat is flowing. However, heat transfer from steam to wort is better described by a more empirical formulation because the system is quite complex and changes with time as scale and baked-on materials (fouling) accumulate on the heat transfer surfaces, impeding heat flow. As wort at boiling temperature flows into the base of a heating tube it flows in as a single, liquid phase and the flow should be fast enough to become turbulent (Fig. 10.1). As it gains heat it begins to boil and bubbles form, creating a second, vapour phase and reducing the density of the wort/steam bubble mixture in the tube. At first the bubbles form on and separate from the wall of the tube, giving saturated, nucleate boiling. However, if the temperature of the walls is too high the liquid may become separated from the wall by a film of steam. This film boiling is undesirable as heat transfer is impaired and solids can be deposited and baked onto the heating surface, causing fouling. To avoid film boiling the temperature of the steam is limited by limiting the pressure to about 3 bar with stainless steel and 5 bar with copper. This difference is because the greater surface wettability of the copper favours the separation of steam bubbles from the heated surface and so favours nucleated boiling (Andrews, 1992; Hancock and Andrews, 1996).

The transfer of heat from steam to wort is less simple than might be supposed. The

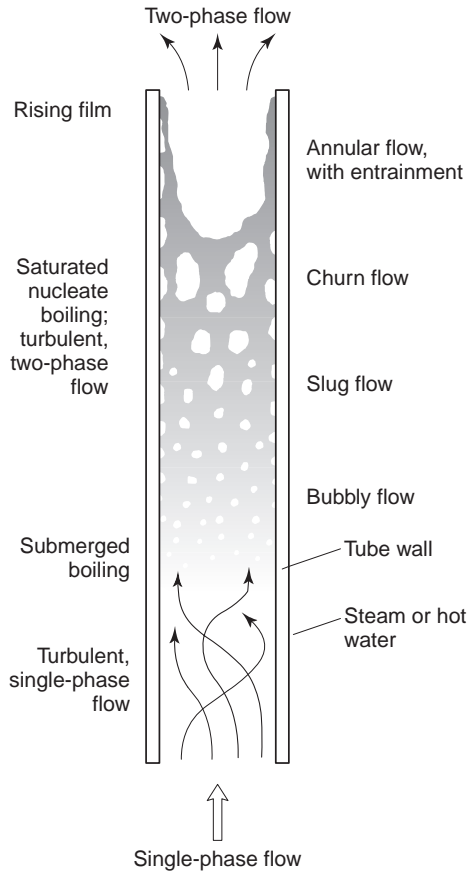

Fig. 10.1 Diagram of the stages of boiling in wort rising up a steam- or water-heated tube (after Wilkinson, 1991a, b). As the wort rises so boiling becomes more vigorous, the flow becomes ‘two-phase’ as steam vapour bubbles appear and come to occupy an increasing proportion of the volume.

temperature in the steam, at a particular pressure, is supported by convection. However, the surface of the wall is covered by a laminar film of condensed water and this, in turn, may be separated from the metal wall of the heat exchanger by a layer of scale deposited from the steam. On the wort side of the wall there may be a deposit of baked-on organic material and outside this fouling, between it and the moving wort, there is a laminar, stationary wort film. The stationary film of condensate, the scale, the metal wall, the fouling and the stationary layer of wort must all conduct heat and all provide resistance to heat flow from the steam to the wort. Heat distribution in the wort flowing up the tube occurs by forced convection. To obtain good mixing and heat transfer to all the liquid the wort must have a turbulent flow, which will partly disrupt the stationary layer. With turbulent flow heat transfer in a liquid is proportional to the (velocity of flow)^{0.8}. With the passage of time the scale and the fouling increase and so, in order to maintain wort boiling, the temperature of the steam side must be increased by increasing the steam pressure.

The heat flow in a wort heater, Q , can be quantified as $Q = UA\Delta T$, where U is the overall heat transfer coefficient of the system, A is the area at right-angles to the heat flow and ΔT is the temperature difference between the bulk of the steam and the body of the

Table 10.2 Typical heat transfer coefficients in wort heaters (kW/m²K) (Hough *et al.*, 1982)

Steam side (low pressure)	5–6
High pressure, hot water side	2.5
Wort side (clean)	1.6
Wort side (dirty)	1.2
Vessel wall (copper; k/x)	19.3
Vessel wall (stainless steel; k/x)	7.5
Overall heat transfer coefficient for a clean, stainless steel vessel	1.0
As above, but for a dirty kettle	0.5

wort. UA is called the heat flux, q , and is given in kW/m². The upper limit of the heat flux, using stainless steel, is about 95, but in practice this is limited to 50 to reduce the risks of fouling. The steam condensate layer, the steam-side scale, the metal wall, the wort-side fouling and the wort stationary layer all contribute to U . With increased fouling or scaling U decreases. Thus this factor in the equation is empirical, it changes with time and must be determined by experiment (Table 10.2). In practical calculations allowance must be made for the fact that heat transfer is into a tube and not across a plane surface. At some point the heat exchanger must be cleaned to remove the scale and the fouling, the heat transfer coefficient, U , is increased and so processing can be resumed using lower pressure steam.

Boiling is accompanied by evaporation and hence an increasing concentration of the wort. One ton of steam can evaporate about 15 m³ of water from wort. The evaporation rate is monitored and as it tends to fall in successive brews, due to the fouling and scaling in the heat exchanger, the steam pressure/temperature is increased to maintain the evaporation rate. By indirectly monitoring the rate of fouling cleaning can be timed to be carried out when it is really needed. The evaporation rate may be monitored by

- automatically determining the level of the boiling wort from the falling pressure at the base of the vessel, using a pressure transducer, or by measuring the depth of the liquid
- measuring steam utilization or condensate production
- automatic sampling and determination of the wort density (SG)
- determining the density indirectly, in the base of the vessel at the inlet to an external calandria heater, by measuring the velocity of ultrasound generated by a transducer. This device is said to be accurate to within $\pm 0.1\%$ SG (Forrest *et al.*, 1993).

With older patterns of coppers cleaning was carried out every 6–12 brews, when the heat transfer rate might have fallen by as much as 25%. Reasons for infrequent cleaning included (i) the difficulty of finding time in a busy brewing schedule; (ii) the costs of cleaning including the costs of detergents, hot water, fitting and dismantling the equipment and the disposal of the effluent; (iii) oversizing the heat exchange surface and (iv) the reduced need for evaporation as weak worts were recycled to the following brew. In newer external wort heaters, (EWH), with rapid, turbulent flow through the heat-exchange tubes, some scouring of the tube surfaces occurs and the large heating areas allow the use of lower wall temperatures and so cleanings can be less frequent, for example having 30 brews between cleanings.

If the pressure on wort is increased the boiling point rises, trub formation and the isomerization of α -acids are accelerated, as are colour formation, DMS formation and other changes. Thus by boiling at elevated temperatures boiling times can be reduced and energy (steam consumption) can be saved. On the other hand the increased removal of protein results in beers with poorer foaming characteristics. It is said that for each 4°C

(7.8 °F) rise in temperature the boiling time can be halved (Chapter 9). However, as the different processes in the wort have different temperature coefficients, the changes in the wort will alter at different relative rates at different temperatures and so the nature of the wort will alter. Some problems encountered in boiling at elevated temperatures are discussed later. Generally boiling wort at, or near, normal atmospheric pressure gives the most acceptable results.

Steam-heated vessels may have jackets or welded semicircular pipes to carry the steam (Fig. 15.2). Sudden steam demands can induce a drop in pressure that can cause jackets to collapse. Pipe heating is more resistant to this kind of damage. Steam is distributed around a brewery in well-insulated mains at a pressure above that needed at the various sites. Valves reduce the pressure at each site to an appropriate extent to achieve the desired temperature. As heat is given up the steam condenses and the condensate is collected and returned to the boiler or sent to drain, without allowing steam to escape. Each heating zone must have a pressure gauge and a thermometer and, for safety's sake, a vacuum valve and a pressure release valve. In addition there must be bleed valves to allow the escape of air when the system is first filled with steam (Kunze, 1996).

10.3 Types of coppers

The increasing sizes of brewing vessels and the need to reduce costs (by increasing heating efficiency) and to reduce the emission of vapours (to meet anti-pollution legislation) have led to the development of a variety of new types of coppers (hop-boilers, kettles). In several cases these, while technically successful in saving energy, produced worts with unacceptable or unusual characteristics. In consequence the use of some vessels has been discontinued while in other cases coppers found unsuitable by some brewers have been retained in use by others, perhaps because of the different characteristics of the beers being produced (Andrews, 1992; Andrews and Axcell (private communication); Clarke and Kerr, 1991; Hackensellner, 1999; Herrmann, 1998a,b; Hind, 1940; Kunze, 1996; Miedaner, 1986; Narziss, 1986a, 1992, 1993; Ormrod, 1986; Rehberger and Luther, 1994; Schwill-Miedaner and Miedaner, 2002; Vermeylen, 1962; Wilkinson, 1985, 1991a, b).

The oldest coppers were made of iron with cylindrical sides and rounded bases and were open to the atmosphere. Often these were replaced by copper vessels of the same type. The copper was mounted in a brick housing with a furnace for burning solid fuel at the base and a flue that wound round the side of the copper to a chimney. At least one such copper is still in use. The copper must be filled with wort before the furnace is fired and the fire must be drawn before the copper is emptied to prevent the heated area becoming too hot, causing wort to burn on. Sufficient space must remain above the fill level to contain the boiling, frothing wort. Such open coppers release steam into the surroundings, creating unpleasant working conditions, condensation and drip-back that leads to deterioration of the building and cleaning difficulties. Whole hop cones are added by hand, in weighed amounts. As kettles became larger and more complex in shape they were increasingly made from copper. Usually they were covered with a dome provided with a chimney to carry steam outside the building and an inspection and access opening, which could be closed with sliding doors. The base was usually hemispherical but sometimes it was domed upwards, to encourage better circulation of the wort. There might be a mechanical stirrer, driven by a shaft from above. Sometimes stirrers,

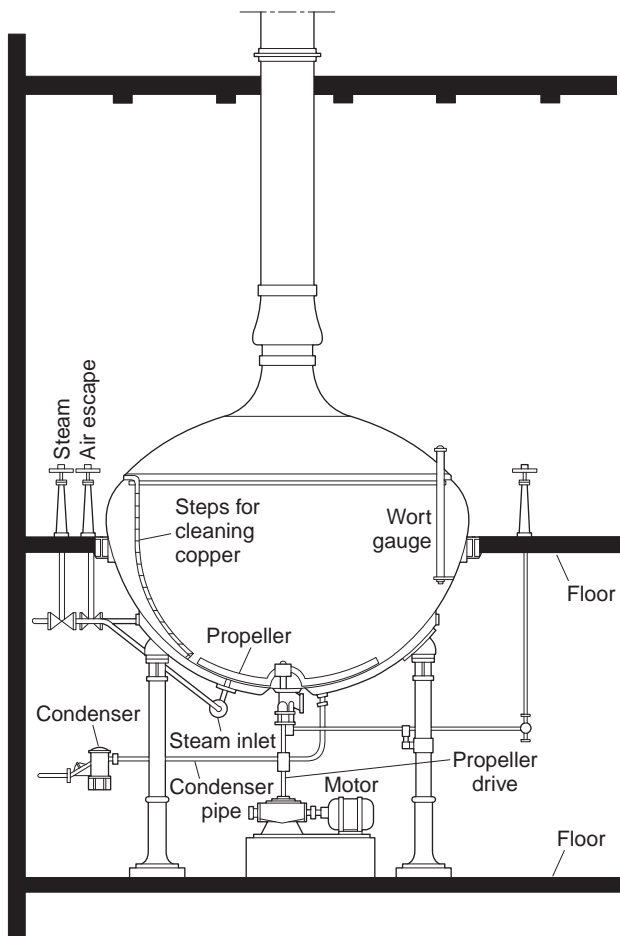

Fig. 10.2 An old pattern of copper having a rounded base and heated by a symmetrical, external steam jacket (after Hind, 1940).

‘rummagers’, carried a series of loops of chain that swept the bottom of the vessel, dispersing deposited materials. It was appreciated that a vigorous ‘rolling boil’ was desirable and that there needed to be an evaporation rate of 8–10% or even 15% of the original wort volume/h. As the boil often lasted 2–2.5 h there was a substantial reduction in the volume of the wort and hence an increase in its concentration. While this allowed the use of large volumes of sparge liquor (and hence a good extract recovery from the mash) it was time consuming and costly because of the large amounts of fuel needed to generate the heat needed to evaporate the water. Direct heating with solid fuels, or oil, or gas has become unusual.

As copper sizes increased it became apparent that simply heating the base, for example with steam (Fig. 10.2), was inadequate because the heating surface area to wort volume ratio decreased with increasing vessel size and it was undesirable to overheat the heating surface. Some brewers used a number of small coppers and filled them and brought them to the boil in sequence, saving time and avoiding having to accumulate the wort in a large copper or underback, with a consequent risk of microbial infection. A partial solution was to have the heating area of the copper divided into zones. As the first, lower zone was

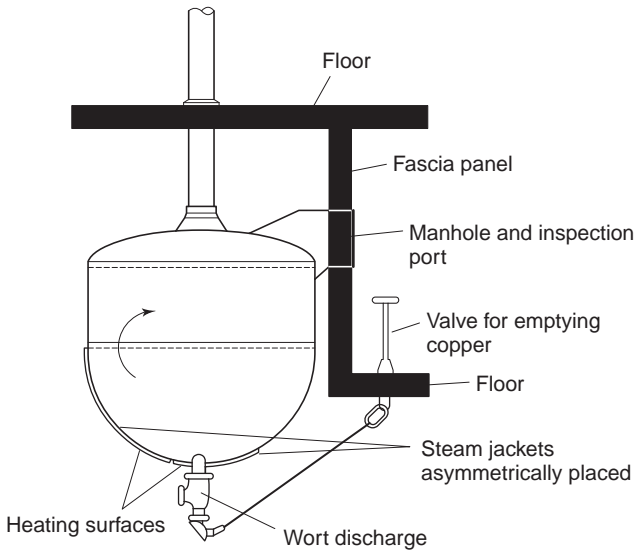

Fig. 10.3 A copper with a rounded base and asymmetrically placed steam jackets (Hough *et al.*, 1982).

covered with wort the heating could be switched on. Wort continued to enter the copper and when the second and third zones were covered steam to these was also switched on, in turn. A second problem was that the even application of heat to the base of a copper with a rounded base gave a poor wort circulation and inadequate mixing. To overcome this some coppers were fitted with mechanically driven impellers (Fig. 10.2) while others were fitted with asymmetric heating panels (Fig. 10.3). The wort adjacent to the heating surface expanded and became less dense, consequently it was driven upwards by the cooler, more dense wort that took its place. With asymmetric heating a strong circulation, with good mixing and a steady upflow of wort across the heating surface, could be achieved.

A so-called 'high-efficiency' copper became popular in Europe, and provided a reference for performance for a number of years (Fig. 10.4; Table, 10.3; Schwill-Miedaner and Miedaner, 2002; Narziss, 1992). With this design steam heating was applied to the base of the copper and to the centrally placed, truncated cone, increasing the heating surface area/wort volume ratio and inducing a convective upward flow of wort in the centre of the vessel and a compensatory flow down the outside. The copper was fitted with an agitator, which assisted the flow and mixing. Another approach was to supplement or replace the surface heating panels with internal heaters. Sometimes these were coils of tubes, but these did not encourage good circulation in the wort and were difficult to clean. Other patterns, such as 'star heaters', which were mounted centrally in the bases of vessels and encouraged an upward, convective flow of a column of wort, were better (Fig. 10.5).

A different approach was to make flat-sided kettles of stainless steel, which were rectangular in plan (Fig. 10.6). Experience showed that wort circulation and mixing was inadequate, despite the asymmetrical disposition of the heaters, and flow had to be assisted by impellers. The headspace was inadequate to accommodate the foam that was generated and the foam had to be broken by downwardly directed jets of air. This was undesirable both from the point of view of favouring undesirable oxidations in the wort and reducing the chances of effective heat recovery by diluting the steam and vapour from the boil with air (Section 10.7).

Table 10.3 The characteristics of some conventional coppers and some other boiling systems (data of Schwill-Miedaner and Miedaner, 2002)

System of boiling	Temperature*		Boiling time (minutes)	Evaporation [†] (%)
	(°C)	(°F)		
'High performance' copper	100	212	120–150	12–16
Internal/external boilers, with back pressure	102–103	215.6–217.4	60–80	about 8
Low-pressure boiler	103–104	217.4–219.2	55–65	6–7
Dynamic low pressure boiling	103–104	217.4–219.2	45–50	4.5–5
High temperature wort boiling	130–140	266–284	2.5–3	6–8
Thin film heating	100	212	35–40	4–4.7

* Temperature at the exit from the heater.

† Percentage of the original volume collected.

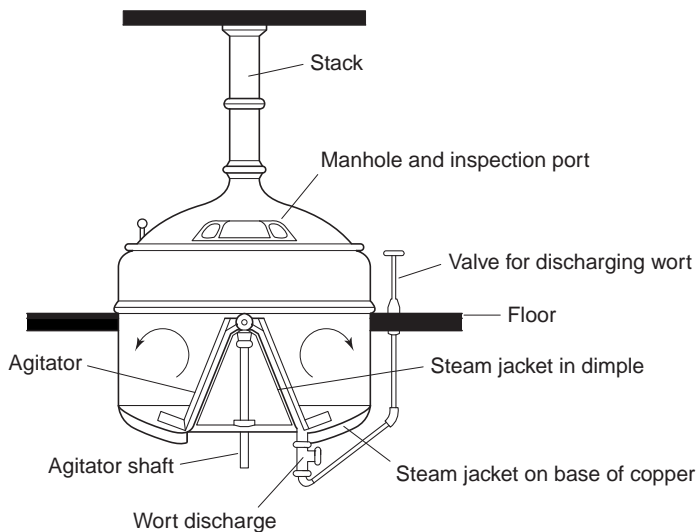
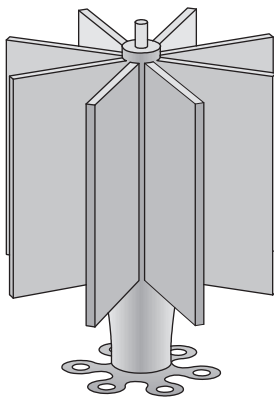
**Fig. 10.4** A 'high-efficiency' boiler having steam heating jackets on the base and on the sides of the central, truncated cone (Hough *et al.*, 1982).**Fig. 10.5** A 'star' steam-heater, designed to have a large surface area while remaining compact, and be suitable for mounting in the base of a copper (Hough *et al.*, 1982).

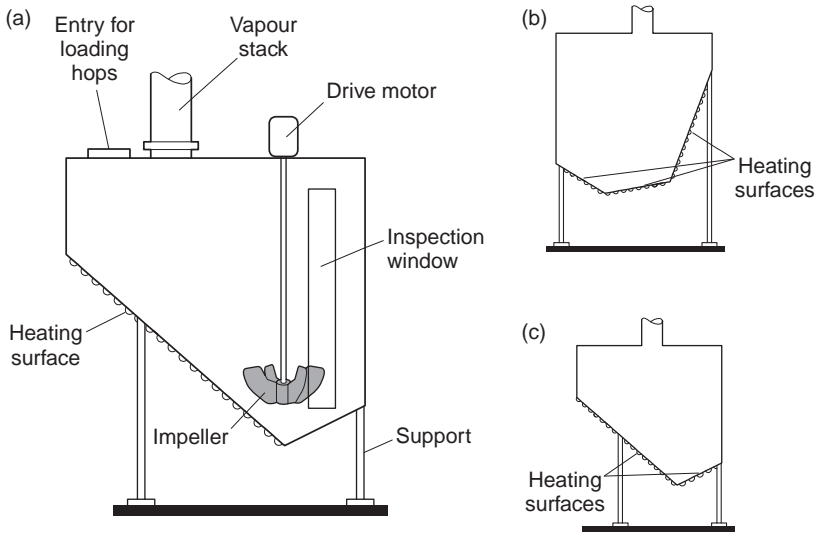

Fig. 10.6 (a) A flat-sided, stainless steel copper (rectangular in plan) with an asymmetric heating surface of semicircular tubes, and an impeller to assist mixing the wort. This design maintained the same size of end wall, but provided vessels of differing capacity by altering the length of the vessel (after Hough *et al.*, 1982). (b) and (c) Cross-sections of alternative patterns of flat-sided kettles (after Rehberger and Luther, 1994).

The increasing costs of fuels and the desire to reduce manpower and increase efficiency have driven the development of new wort boiling systems. Objectives, which are inter-connected, include the reduction in the use of primary energy, (involving the shortening of boiling times and reducing evaporation rates), the recovery and re-use of heat from the copper vapours (and the wort coolers), while avoiding the over-production of warm water, achieving the correct degrees of protein coagulation and removal of volatile substances, the avoidance of excessive colour generation or off-flavours and the maintenance or enhancement of the quality of the wort and the beer made from it. The equipment should be easy to clean and maintain and should not require cleaning too frequently. At least in large breweries cleaning should be fully automatic (CIP; cleaning in place) and not require the direct use of manpower.

Newer coppers usually employ internal or external heaters in which the wort passes upwards through tubes surrounded by a steam-heated chamber. Figure 10.7 shows an internal heater in which the wort flows upwards through the heating unit into a constricting tube (sometimes called a Venturi tube), emerges above the level of the wort and strikes a deflector plate which directs it back as a spray onto the surface of the wort. In some instances two plates are used to direct the spray to the edge and to the midpoint of the radius of the copper. The sprays ensure a good circulation of the wort, they serve to 'beat-back' foam and, by breaking the wort-stream into small droplets, they create a large surface area from which volatiles can evaporate into the vapour stream, which leaves the copper via the chimney. Being immersed in the wort internal, heaters are efficient but their size is restricted by the geometry of the vessel. This means that the heating surfaces must be heated to a relatively high temperature to obtain the necessary heat flux to obtain a vigorous boil and this, in turn, leads to faster fouling and more frequent cleaning (sometimes as often as every six brews). By restricting the flow of wort in the Venturi tube a small back-pressure can be achieved, raising the boiling point

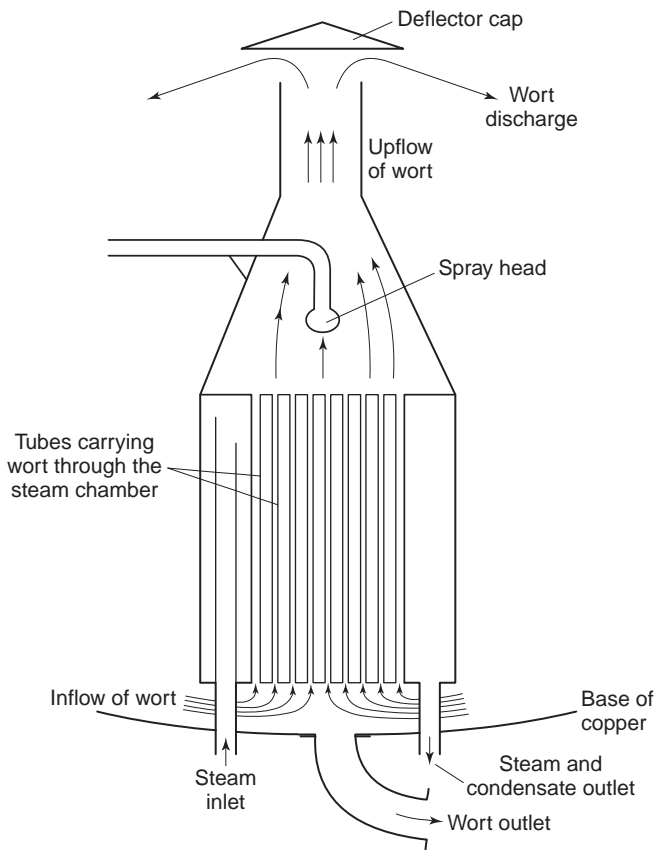

Fig. 10.7 An internal heater and ‘fountain’ for coppers in which the wort moves up the steam-heated tubes by convection, its flow is constricted, then it emerges from beneath the wort level and strikes the deflector plate which directs it down onto the wort surface (Various sources).

of the wort to 102–103 °C (215.6–217.4 °F). In part the size limitation for internal heaters may be offset by increasing the depth of the copper under the heater which, in consequence, can be relatively larger (Fig. 10.8).

If the wort has not been pre-heated it arrives at the copper at mashing and sparging temperatures, about 75 °C (167 °F), and must be heated to boiling in the copper. With simple internal tubular heaters it is sometimes found that violent pulsations occur until the pre-heating period is complete (Stippler *et al.*, 1997). This phenomenon resembles ‘boiling with bumping’, familiar to chemists. The static, cool wort in the tubes is heated to boiling and then wort and vapour escape violently to be replaced with more cool wort. The process is repeated until the bulk of the wort is nearly boiling, when a steady stream, driven by convection, flows upwards through the heater. Mechanically driven impellers have been installed below some heaters to drive the wort upward through the heater during the heating phase and so avoid the pulsations. An alternative approach is to pump wort from two separate sites at the base of the copper, using the casting pump, and deliver it into the base of the internal heater, creating a forced upward flow over the heating surfaces (Hackensellner, 1999). When the wort is boiling steadily good mixing occurs.

All efficient modern coppers are ‘closed’, and so the steam is not diluted with air once boiling is established and has driven the air from the system, and so is available for heat

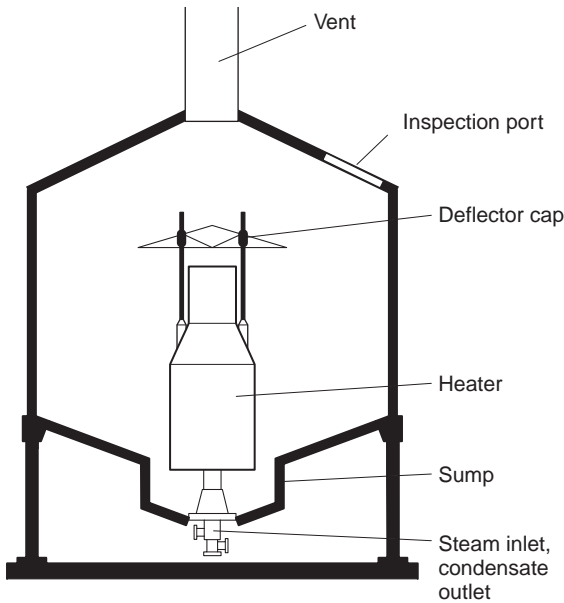

Fig. 10.8 A diagram of a copper having an internal heater, mounted over and extending partly into, a 'cup' or 'sump'. The extra depth permits the heater to be larger than would otherwise be the case, and so it has a large heat transfer surface (after Michel, 1991).

recovery. Internal heaters are less easily cleaned than external heaters. Boils of 60–80 min., with total evaporations of around 8% are often suitable. External tube-and-shell, wort heaters (EWH), previously called 'calandria' heaters are often preferred (Andrews, 1992; Andrews and Axcell (private communication); Hancock and Andrews, 1996). Their size and geometry is not restricted by the dimensions of the kettle. Consequently the heat-exchange surface area can be relatively large, allowing lower wall temperatures, so less fouling is likely. External heaters are easily cleaned and may be retro-fitted to existing coppers. In an early version, wort was drawn from the base of the copper through an axial flow pump and then upwards through a tube-and-shell 'calandria' steam heater and back into the vessel into the base of a Venturi 'fountain' and was directed back onto the surface of the wort by a spreader (Fig. 10.9a). The axial flow pump remained running until the wort was boiling, then it was shut off and circulation in the system was maintained by the 'thermosyphon' effect, driven by the reduced density of the wort boiling in the external heater being displaced upwards by the cooler, denser wort in the body of the vessel.

The original heaters were comparatively short (1–1.2 m; 3.28–3.94 ft.) and had wide wort-carrying tubes (c. 75 mm; 2.95 in. diameter) to accommodate the passage of whole hops. If milled or milled and pelleted hops are used longer (2.5–4.5 m; 8.2–14.76 ft.) and narrower tubes (25–65 mm; 1.00–2.59 in.) may be used having greater heat exchange efficiency. A vessel to boil 1000 hl (611 brl) of wort, and equipped with an external heater, might be 5.8 m (19.03 ft.) in diameter and the straight sides be 4 m (13.12 ft.) high. External wort heaters have been developed in two directions. In one the wort is pumped through the heater continuously during heating up and during the boil. In some cases these heaters may be mounted horizontally and/or the tubes may be bent into a distorted 'S' shape, so that they traverse the heating steam chamber three times. At the exit of the heater a restriction valve may provide back-pressure raising the temperature of the wort

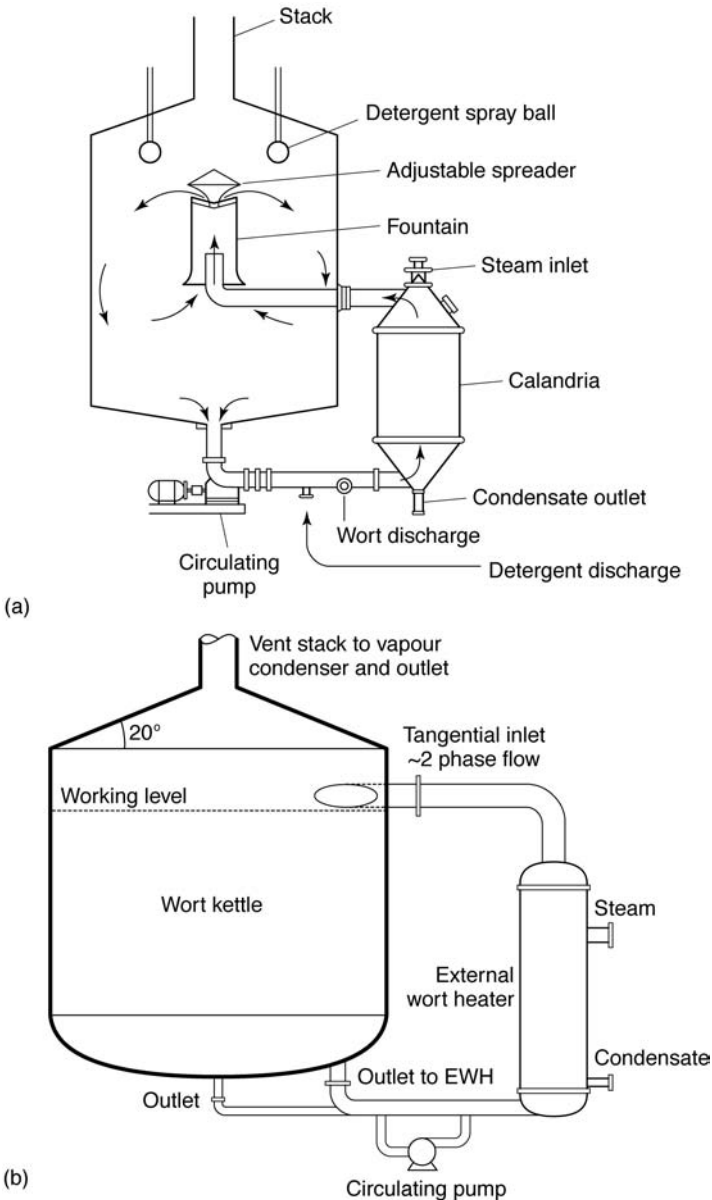

Fig. 10.9 (a) A copper heated by a comparatively small external shell-and-tube calandria heater (Hough *et al.*, 1982). This is an older design in which the pump initiated wort circulation but which relied on the circulation being driven by the thermosyphon effect once boiling was established. (b) In newer designs the wort flow is directed around the pump in a bypass loop when boiling is occurring. Wort from the EWH may be discharged above or at the wort surface. (Courtesy of Briggs of Burton, plc.). Alternatively, the wort may be discharged through a 'fountain', as in the older pattern.

in the heater to 103–104°C (217.4–219.2°F), allowing a shortened boil of 60–70 min. Although higher temperatures can be attained (e.g. 110°C; 230°F) they are generally not used because wort quality can be impaired (Narziss, 1993; Narziss *et al.*, 1992). The release of pressure at the valve favours the rapid production of small vapour bubbles,

which are efficient at carrying unwanted volatiles away into the vapour stream. Using this system the heater must be pressure resistant, the pump must run continually, with implications for maintenance and running costs, and the shear provided in the pump and the restriction valve tends to break up the flocs of trub (hot break), complicating the subsequent clarification of the hot wort.

Other external heaters (EWH) rely on the thermosyphon effect to drive the circulation of the wort once the system has reached boiling (Andrews, 1992; Andrews and Axcell (private communication); Hancock and Andrews, 1996; Wilkinson, 1991a, b; Fig. 10.9b). While the wort is being heated to boiling it is recirculated through the EWH by a pump in a bypass loop. Once boiling is established, and can be driven by the thermosyphon effect, the pump is bypassed, the wort flow is directed to a simple loop of obstruction-free pipework from the base of the copper into the base of the, vertically mounted, EWH. The absence of pumping saves power, and wear on the pump and avoids the liquid shear in the pump. The large sizes of EWHs, that can be used, allow low heating temperatures to be applied and hence much slower fouling. For example, with 7% evaporation/h, a heat transfer of 4.63 kW/hl and the same heat transfer coefficient then a typical internal heater might have a working area of 0.08 m²/hl while an external heater could have 0.20 m²/hl. The steam/wort temperature differences would be 37 °C and 15 °C (66.5 °F and 27 °F) respectively (Andrews and Axcell, private communication). Wort passes through these heaters at the rate of 6–10 or even 12 vessel volumes/h. The scouring effect of the wort and the low wall temperatures needed to maintain the correct heat flux minimize fouling and so the necessary cleaning frequency may be less than once in 30 brews.

The temperature of the wort in the heater (not in the body of the kettle) may reach 105 °C (221 °F). The wort emerges from the return pipe and is injected tangentially, by the force of the flow, either into the wort or, preferably, just above its surface. In each case the wort is driven to rotate in the kettle, giving good mixing, and in the second case the vigorous breakout of the vapour bubbles, initiated by nuclear boiling, efficiently evaporates a proportion of the volatiles. Evidently this arrangement is suitable for combined kettle/whirlpool vessels (Section 10.8). The high efficiency of volatiles removal, (only 4% evaporation may be needed), reduces the need for lengthy boiling and so shorter, less energy-costly boiling, is possible. This, in turn, means less primary energy is needed, less fuel is used and so carbon dioxide emissions are reduced. In a few small breweries plate and frame heat exchangers are used as EWHs.

A recent wort-boiling ‘Merlin’ system uses a thin film boiling and evaporation unit (Fig. 10.10; Schwill-Miedaner and Miedaner, 2002; Stippler, 2000). In this system wort is pumped from a whirlpool vessel (Section 10.8) and is discharged onto the apex of a metal cone, the upper third and lower two-thirds of which are independently heated by steam. The cone is enclosed in a vessel with a vapour-escape chimney. The wort flows downwards and boils in a thin, turbulent film over the heating surface and is then collected in a circumferential gully from which it flows back to the whirlpool tank. This arrangement ensures a good evaporation of volatiles. The returning wort enters the tank at two locations, at the centre and tangentially at the periphery, where its entry drives the rotation of the vessel’s contents. The two points of entry favour mixing. The heating phase, during which hops are added, may be for 35–40 min., with both zones of the heating cone at 130 °C (266 °F). The boil, which lasts about 40–60 min., takes place with only the lower zone being heated, to c. 120 °C (248 °F). During the heating-up period the wort is pumped at a rate of about 4–6 vessel volumes/h, while during the boil the rate is 4 volumes/h. At the end of the boil the heater and pump are turned off and then, after the whirlpool rest (which may last as little as 10 min. because initial trub separation occurred

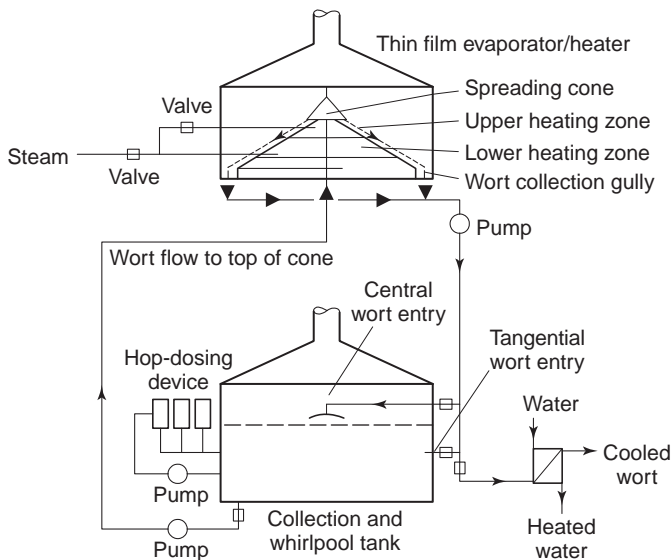

Fig. 10.10 A diagram of a 'Merlin' wort boiling system in which the wort is collected in a whirlpool vessel and is heated, boiled and volatiles are stripped by pumping it in a thin film over a steam-heated cone in a separate vessel (after various sources, including Anton Steinecker literature).

during the boil; Section 10.8), the clarified wort is pumped out over the heating cone to the cooler. At this stage only the lower part of the cone is heated to 116–120 °C (c. 241–248 °F). This 'volatiles stripping' stage reduces the level of DMS very substantially. The total evaporation is about 4.5% of the initial wort volume, of which 1.5–2.5% is removed during the boil, the remainder during stripping. Thus this boiling system is energy efficient.

10.4 The addition of hops

In older and/or smaller breweries it is normal to add weighed amounts of hops (whole hops, milled hops, pelleted milled hops or hop extracts) to the coppers by hand (Chapter 9). Traditionally, English beers were hopped at rates of 0.5–3.5 lb./imp. bbl (0.139–0.970 kg/hl; Hind, 1940; Chapter 9). Manual additions are hazardous as the wort may suddenly boil up and over, and late additions, as with aroma hops, mean that air is admitted to the copper, which interferes with heat recovery from the vapour. There seem to be no good ways of automating additions of whole hops, but means of adding hop powders, pelleted hop powders and hop extracts have been automated (Anon., 1994; Benitez *et al.*, 1997; Boyes, 1993; Kollnberger, 1986, 1987; Kunze, 1996; Langenhan, 1995). Additions may be regulated by weight or by α -acid content and several additions may be made at different stages of the boil. Hops may arrive at the brewery in bales, pockets, foil-lined bags or boxes. Extracts come in cans or in 80- or 200-litre mild steel disposable drums or in 1000-litre, returnable stainless steel drums.

The hops or hop preparations must be stored cool and dry. Often the store is not adjacent to the copper(s). Thus the hops must be unpacked (containing any dust that is generated), be transferred to the brewhouse and weighed amounts be delivered to each

brew at the correct stage. Unpacking can be laborious and, if automated, only one or two types of packing can be handled conveniently. In one system boxes of pellets are conveyed forward on a roller conveyor by gravity and, when the depth of pellets in a feed hopper has fallen to a predetermined extent, a box is opened, by two saws that automatically remove the ends. The empty box is discarded, its place being taken by the next full box, while the pellets fall into the hopper. Discharge from the hopper may be through a vibrating feeder into a weigher that determines the dose. Pellets can be transferred by mechanical or pneumatic means, provided these are not too damaging, or they can be broken up and be pumped after being slurried with wort or water. Pellets can become 'sticky' and conveyers become contaminated and need regular cleaning. Pellets may be weighed into a conveyor and delivered directly into the copper, precautions being taken to prevent steam wetting the conveying system.

With pressurized coppers the dose passes through the first valve, which is then closed, the pressure is equalized, then the second valve is opened and the hops are discharged into the vessel. In a different system each batch of hops or hop extract is weighed into a small pressure vessel and, at the appropriate time the hop 'dose' is flushed into the copper with hot water or hot wort. If different types of hops are to be added at different stages of the boil each batch must be in a different vessel. In yet another system hop pellets or extracts are slurried in hot water or wort and aliquots are pumped into coppers as required. Hop extracts may be added by suspending punctured tins in baskets immersed in the boiling wort. Alternatively, drums of extract may be pre-heated to not more than 45–50 °C (113–122 °F) for 24h to reduce the viscosity, then the extract can be added to the wort flowing into the copper via a metering pump, or may be added with a flush of hot wort or water. Hop oils may be added in at the end of the boil and it has been proposed that hop oils in the vapour condensate could be collected and added back in the same way.

10.5 Pressurized hop-boiling systems

The boiling point of water or wort depends on the pressure, (Appendix A.11), and so varies with changes in the atmospheric pressure. In breweries situated at high altitudes it is necessary to be able to seal and pressurize the coppers to elevate the boiling temperature to at least about 100 °C (212 °F). It has long been realized that by boiling wort at elevated temperatures hop α -acid utilization is increased and potentially wort boiling can be shortened with savings in time and energy (Chapter 9). The acceptability of this approach is disputed. Recently, three types of elevated temperature/pressure boiling systems have been advocated, mainly in continental Europe. These have been called 'low-pressure boiling', 'dynamic low-pressure boiling' and 'continuous, high-pressure boiling'.

10.5.1 Low-pressure boiling

Low-pressure boiling involves increasing the 'overpressure' in the copper (the pressure above atmospheric) to a relatively small extent, giving absolute pressures of up to 2 bar. This can be carried out in sealed and strengthened coppers with internal or external heaters. Temperatures of up to 110 °C (230 °F) have been used, but lower temperatures seem to be preferred, at pressures of 1.5–1.9 bar (Herrmann, 1985; Narziss, 1986a, b). A problem with low-pressure boiling is an inadequate evaporation of volatiles from the

wort. In a particular schedule wort is boiled for ten minutes at atmospheric pressure, when 1.3% evaporation occurs. The copper is sealed and the pressure rises, over ten minutes, until 106 °C (222.8 °F) is reached and 0.5% evaporation has occurred. This temperature is maintained, during boiling, for 18 minutes, when a further 1.3% evaporation takes place. Over 15 minutes the pressure is reduced until the temperature has declined to 100 °C (212 °F), allowing evaporation of 1.7%. Finally, the wort is boiled at atmospheric pressure for ten minutes, achieving a further 1.3% evaporation, giving 6.1% (6–7%) evaporation in total. This reduces boiling time by 20–30%, relative to unpressurized controls, and is convenient for energy recovery from the vapour (Section 10.7).

10.5.2 Dynamic, low-pressure boiling

Dynamic, low-pressure boiling is designed to achieve a more rapid evaporation of volatiles and so a smaller, less costly total evaporation rate. Where the evaporation in a 'traditional' boil is 8–10%/h, and in a low-pressure boil is 6–7% in total, that achieved in a dynamic, low-pressure boil may be 4–5% in total (Kantelberg *et al.*, 2000). In this system the pressure in the copper is allowed to increase, e.g., to 1.17 bar, and then is allowed to fall, e.g., to 1.05 bar, with 6–7 pressure changes/h, giving temperature changes between 101–102 and 104–105 °C (213.8–215.6 and 219.2–221 °F). Each time the pressure is released there is a massive release of small bubbles throughout the wort, which carry volatiles to the surface. The reduction in unwanted volatiles is good, with a total evaporation of 4.5–4.8%.

10.5.3 Continuous, high-pressure boiling

Continuous, high-temperature wort boiling has been tried in various systems, with limited success (Chantrell, 1983, 1984; Grasman and van Eerde, 1986; Rehberger and Luther, 1994). The most successful attempts involved heating at 130–140 °C (266–284 °F) for 150–180 s. Savings in steam utilization of 60–65% were claimed (Fig. 10.11). Wort from a collection vessel at around 72 °C (161.6 °F), to which hop extracts are added, is successively heated in three heat exchangers to 90 °C (194 °F), 106 °C (222.8 °F) and 140 °C (284 °F) using vapour from the expansion tanks in the first two heaters and live steam in the third as the heating agents. The wort is maintained for three minutes at 140 °C (284 °F) in a holding tube, then it is cooled in two stages in expansion vessels which successively reduce the temperature to 120 °C (248 °F) and 100 °C (212 °F). The vapours, which flash off during boiling only in the flash-tanks, remove volatiles and transfer their heat to the incoming wort stream through the first two heat exchangers. The wort is then sent to the whirlpool/clarifier. The system is energy-efficient, but wort is darkened and good beer qualities have not always been achieved. The fouling of the equipment at the high temperatures used necessitates frequent cleaning using strong caustic solutions and hydrogen peroxide.

10.6 The control of volatile substances in wort

It is apparent, from the points made above, that the removal of unwanted flavour and aroma volatiles is essential and that this may be achieved, in the appropriate equipment, without the traditional high evaporation rates. In many cases the removal of volatiles

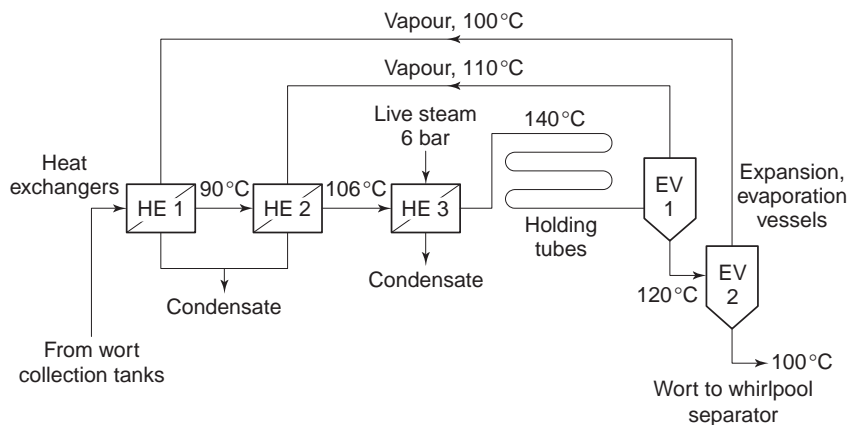

Fig. 10.11 A scheme of a high-temperature wort boiling system (after Chantrell, 1983; Clarke and Kerr, 1991). The vapours from the expansion vessels (EV 1 and 2) heat the wort in the first two heat exchangers (HE 1 and 2). Heat is provided to the third heat exchanger, (HE 3), raising the temperature of the wort to 140°C (284°F), by live steam. This temperature is held for three min. during the passage of the wort through the holding tube. The reduction in temperature and evaporation occurs in two controlled steps, when the wort is boiled in the expansion vessels and unwanted volatiles are removed.

achieved during the copper-boil is not sufficient because, as with DMS, more are formed during the whirlpool rest or during the hold in the settling tank, periods during which the hot wort is clarified. Boiling wort most readily gives up volatiles when it is finely dispersed as in a copper with a Venturi tube and spreader or when it is discharged from an external heater in a two-phase mixture of liquid and vapour bubbles above the surface, or if the pressure on the boil is reduced causing the creation and escape of many small bubbles. Evaporation from coppers has also been improved, and the boiling time reduced, at least experimentally, by sparging the boiling wort with an inert gas, nitrogen, introduced at the base of the copper (Mitani *et al.*, 1999). Maule and Clark (1985) demonstrated that boiling might be avoided by simmering the wort at 93°C (199.4°F), removing sufficient protein by treatment with silica hydrogel and removing volatiles by spraying the wort into an evaporation chamber held under a partial vacuum. Volatiles removal also occurs in the flash evaporation chambers used in continuous, high-temperature boiling (Fig. 10.11), and is of value in treating worts being transferred from the clarification vessel to the cooler (Lustig *et al.*, 1997).

Other approaches have been used to remove unwanted volatiles, generated in the hot wort during clarification rests. This can be achieved by heating a thin layer of wort during the transfer from the whirlpool tank to the cooler (Stippler, 2000; Fig. 10.10). An alternative approach is to ‘steam-strip’ the wort (Bonachelli *et al.*, 2001; Braekeleirs and Bauduin, 2001; Seldeslachts *et al.*, 1997; Fig. 10.12). In the stripper the wort is pre-heated to boiling and is then sprayed into the top of a column packed with rings and saddles giving a high surface area of 50–500 m²/m³. As the wort percolates downwards, as a thin film over the column packing, it meets a slow counter-flow of live steam moving upwards. This adjustable process carries away volatiles to a condenser and 0.5–2% evaporation occurs. Heat may be recovered, as hot water, from the condenser. The stripped wort moves directly to the cooler.

By cooling the wort, e.g., to 89°C (192.2°F), during its transfer from the copper to the whirlpool tank, the reactions proceeding in the wort in the whirlpool are usefully slowed

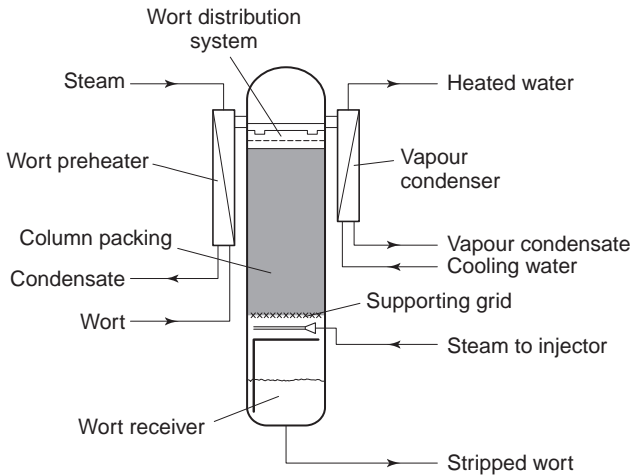

Fig. 10.12 A steam stripper for removing volatiles from wort (after Bonachelli *et al.*, 2001; Seldeslachts *et al.*, 1997).

and fewer volatiles are formed. Cooling may be achieved using cold water and a plate heat exchanger (producing warm water), or by expansion in a vacuum chamber (Lustig *et al.*, 1997; Krottenthaler and Back, 2001; Krottenthaler *et al.*, 2001).

10.7 Energy conservation and the hop-boil

Energy and warm water production and consumption link all parts of the brewing process (Manger, 1998; Schu, 1995; Unterstein, 1992). As far as possible ‘waste’ heat, that is heat other than that derived directly from primary heating, must be conserved and utilized. This implies ‘good housekeeping’, well-insulated vessels, no steam or other leaks, automatic controls where possible, efficient designs of plant and brewing operations, and well-trained staff. Thus, besides steam and other ‘direct’ heating, heat as vapour or hot water is produced in mash- (decoction) and adjunct-cooking, in wort boiling and in wort cooling. Hot water can be or is used in pasteurizers, in pre-warming lauter tuns or other vessels, in mashing in, in sparging, in preheating wort before it reaches the copper (to avoid a sudden high demand for steam), in copper boiling, in CIP and other plant cleaning and in cleaning cans, kegs, casks and bottles as well as space heating, in preheating boiler feed and even heating anaerobic waste digestion plant. This section is particularly concerned with saving heat during hop-boiling, but it is unrealistic to consider this in isolation from the rest of the brewing process (Boer, de 1991; Clarke and Kerr, 1991; Fohr and Meyer-Pittroff, 1998; Herrmann, 1998a, b; Kunze, 1996; Lenz *et al.*, 1991; Miedaner, 1986; Narziss, 1993; Reed, 1992). Heat recovery from boiler vapours requires that the system is purged and air-free. The practice of letting air into the copper, to reduce fobbing and to increase the draught up the stack to encourage evaporation, as well as encouraging wort oxidation, blocks heat recovery (Hough *et al.*, 1982).

Heat recovery from the vapours generated during hop-boiling has attracted much attention. In one, relatively simple, system vapour from pairs of boiling coppers was fed into a main and was condensed initially with jet condensers but subsequently, and with much greater efficiency, by cold or warm water sprays (Morris, 1987). A rise in temperature in the main, caused by the arrival of vapour from the boiling coppers,

automatically triggered the first of a pair of sprays to come on. If the temperature of the main downstream from the first spray rose, indicating incomplete vapour condensation, a second, back-up spray came into operation. A key factor was the use of decarbonated water in the sprays, to avoid the deposition of scale in the pipes. Heat recovery in the resultant hot water was $> 95\%$. Cold water at about 7°C (45°F) was used initially in the sprays and water with vapour condensate at about 90°C (195°F) was produced. Later warm water was used in the sprays. The small amounts of organic materials present in the hot water had no unwanted effects. Only a small amount of cooled vapour was discharged outside the building, and so the escape of organic materials and odours was negligible.

Vapour condensers, which are widely used, produce hot water by heating cooling water, while the vapours from boiling wort (or mash) are condensed. The hot condensate may be cooled further in a heat exchanger before being used as a first cleaning rinse or being directed to waste. The warmed water produced when cooling the condensate may be used in various ways, including being the cooling feed to the vapour condenser, where it is heated to a substantially higher temperature. Copper condensers, or economizers, are not new; one was illustrated in 1875 (Narziss, 1986b). They may be used with internally or externally heated coppers, boiling at either ambient or elevated pressures. They are invariably used in thermal vapour recompression systems (see below). A system in which hot water from a condenser is used, in conjunction with a hot water, 'energy storage tank' to heat a mash-mixing vessel is shown in Fig. 10.13. The temperature of the heated water is regulated by how the system is operated but is generally between 80 and 98°C (174.2 and 208.4°F). In principle, it is desirable to use 'waste' heat as it becomes available. However, as brewing schedules often cannot be arranged to achieve this it is necessary to have well-insulated hot water storage tanks to act as 'energy stores'. These are arranged in various ways, for example, single, tall and relatively narrow tanks with thermal gradients (Fig. 10.13) or linked pairs of tanks may be used (Vollhals, 1994).

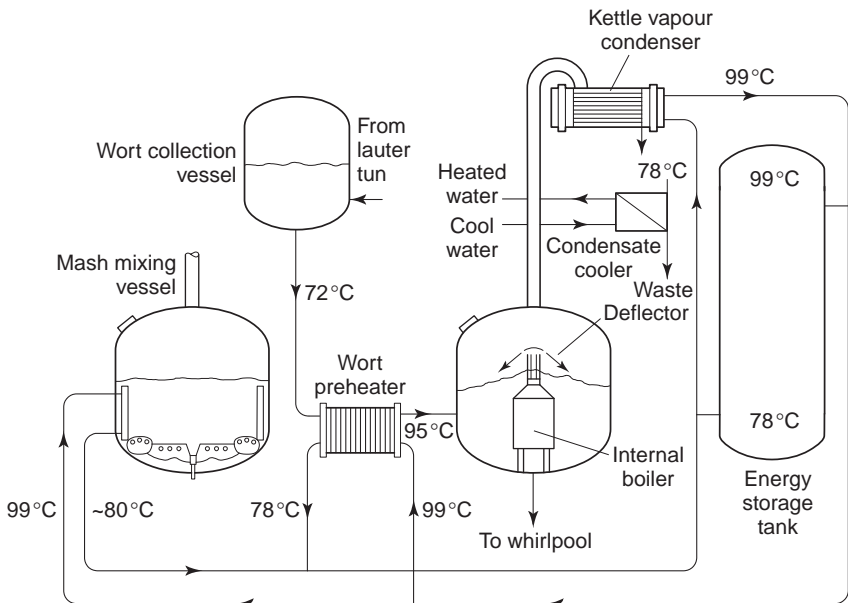

Fig. 10.13 An arrangement where vapour from a kettle is condensed and heat recovered in hot water is stored in a temperature gradient tank and is partly used to heat the wall jacket of a mash mixing vessel and the wort from the lauter tun, before it enters the copper (after Herrmann, 1998b).

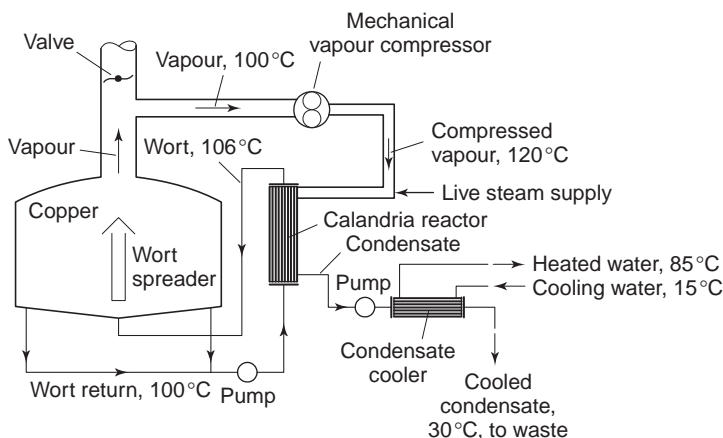

Fig. 10.14 Outline of a mechanical vapour recompression (MVR) system (after Fortuin, 1995). During boiling the wort, passing through the external wort heater, is heated by the compressed vapours from the copper, supplemented with live steam as needed. Condensate from the wort heater is cooled, water being heated in the process.

Wort cannot be boiled with water vapour at 100 °C (212 °F). However, if the vapour is compressed its temperature rises and, provided that the heat exchange area is adequate, as can most easily be arranged with external copper heaters, boiling can be supported by the heat in the compressed vapour. In a mechanical vapour recompression system (MVR), once all the air has been displaced from a closed copper, a compressor (screw-, turbo- or rotary piston-compressor; often a Rootes compressor) is switched on. The vapour is compressed to have an overpressure of 0.2–0.7 bar, and a temperature of 108–112 °C (226.4–233.6 °F). This vapour is returned to the copper heater and, by condensing and giving up its latent heat in the normal way, maintains boiling, with supplementary additions of live steam if necessary (Fig. 10.14). This system uses electrical energy to drive the compressor. Compressors can be expensive and noisy and need regular maintenance. On the other hand steam savings of 60% are claimed and, in contrast to the TVR system (see below), the only hot water produced is from the heater condensate heat exchanger/cooler.

The thermal vapour recompression systems (TVR) have the same objectives as the MVR systems, but vapour recompression is achieved using a steam jet compressor, an important consequence of which is that substantial amounts of hot water are generated. The economics of this system largely depend on whether this hot water is needed. In the compressor a jet of live steam, regulated by a needle valve, enters a chamber where it draws in vapour from the copper stack and mixes with it and carries it forward to an expansion chamber where it slows down and the pressure rises (Fig. 10.15). Values vary, but the live steam must have an adequate pressure, at least 8 bar up to 24 bar. The compressed vapour has an overpressure of 0.3–0.4 bar and a temperature of 106–110 °C (222.8–230 °F). A good proportion, preferably the major part, of the vapour (55–74%) is compressed and used to support the boil in the copper while the remainder is diverted to a condenser which heats cooling water to 80–95 °C (176–203 °F; Fig. 10.16).

The vapour condensate joins the condensate from the wort heater and passes through a cooler, which generates warm water, and cool condensate, which may be used or be diverted to waste (Dymond and Djurslev, 1994; Fohr and Meyer-Pittroff, 1998). The

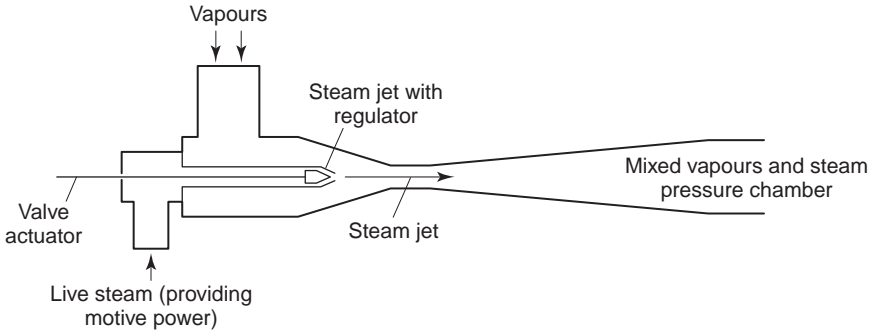

Fig. 10.15 The principle of a steam-jet vapour compressor. A regulated jet of live steam sucks vapours into the nozzle. As the cross-sectional area of the tubing widens the stream of mixed steam and vapour slows down and the pressure rises, e.g., to 1.2–1.7 bar (104.8–115.2 °C; approx. 221–239 °F).

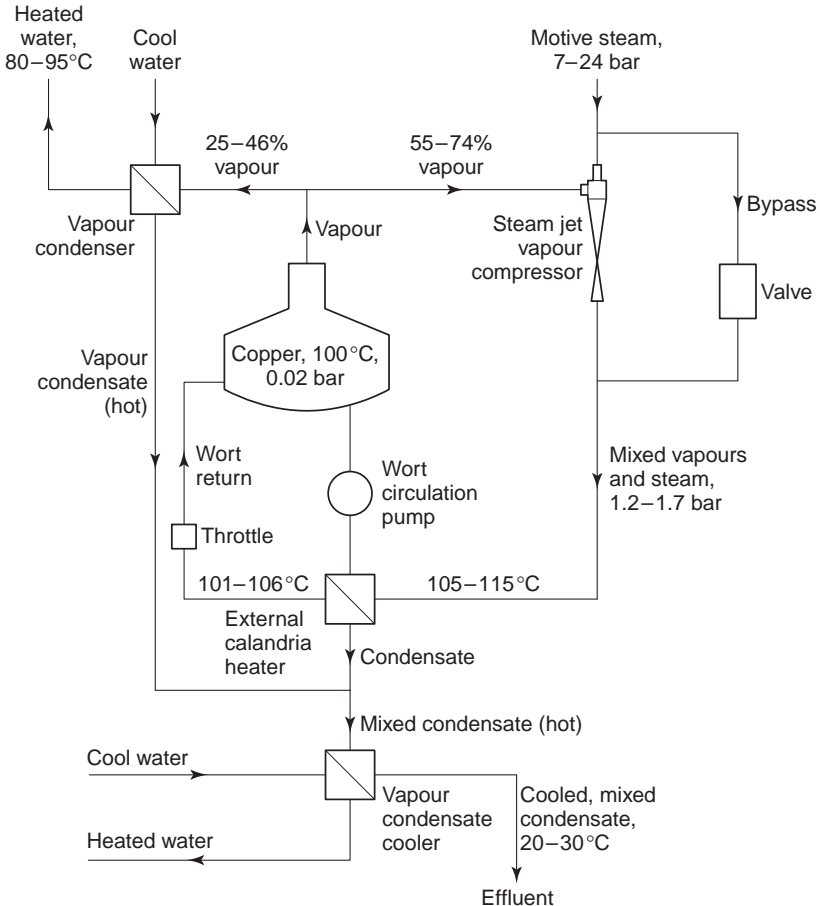

Fig. 10.16 A thermal vapour recompression (TVR) system (after Fohr and Meyer-Pittroff, 1998). The wort is boiled, under pressure, by the compressed mixture of vapour and steam from the steam jet vapour compressor. Vapour from the copper that is not compressed is condensed and used to heat water in the process. Mixed condensates from the vapour condenser and the heater are cooled and sent to waste. Hot water is also obtained from this operation.

warm water from the condensate cooler may be used as the cooling water in the vapour condenser. Such systems use the vapour with 40–50% efficiency and produce hot water in amounts of 0.2–1.5 hl/hl of beer produced. TVR systems may be suitable for smaller and medium sized breweries. The investment in the steam jet compressor is relatively small, little maintenance is required and the compressor should run quietly. The system must be purged and air-free before it can operate. It must be free from leaks.

10.8 Hot wort clarification

At the end of the boil the wort should be absolutely clear ('bright') but contain, suspended in it, the remains of hops and flocs of trub or hot break. If whole hops are employed then the spent hops will probably weigh 0.7–1.4 kg/hl (2.4–5.0 lb./imp. brl) wet weight and will be associated with a significant amount of wort. The trub will be in the region of 0.21–0.28 kg/hl (0.75–1.0 lb./imp. brl) wet weight and will contain 80–85% water (Hough *et al.*, 1982). Hot break contains roughly 50–60% crude protein, 20–30% tannin, 15–20% resins and 2–3% ash (dry wt., Andrews, 1992). Significant quantities of lipids are also present. Flocs of trub may reach 5–10 mm in diameter, but these can easily be disrupted, e.g., by pumping, into particles of 20–80 μm diameter and a greater exposure to shear will reduce these to particles of 0.5–1.5 μm . The hot break should be removed from the wort as thoroughly as possible, and this is most easily achieved with large particles. Consequently boiled wort should be handled gently and shear should be avoided to minimize damage to the trub.

The methods used to separate spent whole hop cones and the remains of milled or pelleted hops are different. In older, small breweries the remains of the hops were removed from the wort, when it was cast from the copper, by straining it through a cloth bag or a sieve. In larger breweries the hops were sieved out of the wort using a Montejus or hop jack (Fig. 10.17). Some trub was retained with the spent hops, which

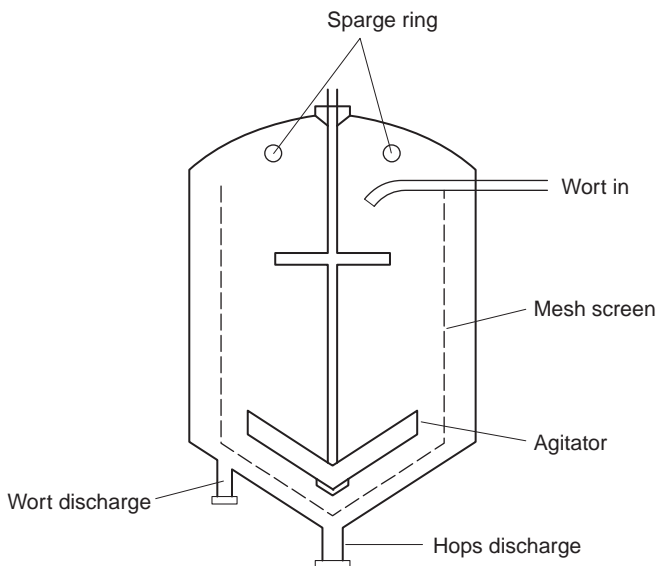

Fig. 10.17 A Montejus, or hop jack, used for sieving whole hops from wort when it is discharged from the copper (Hough *et al.*, 1982).

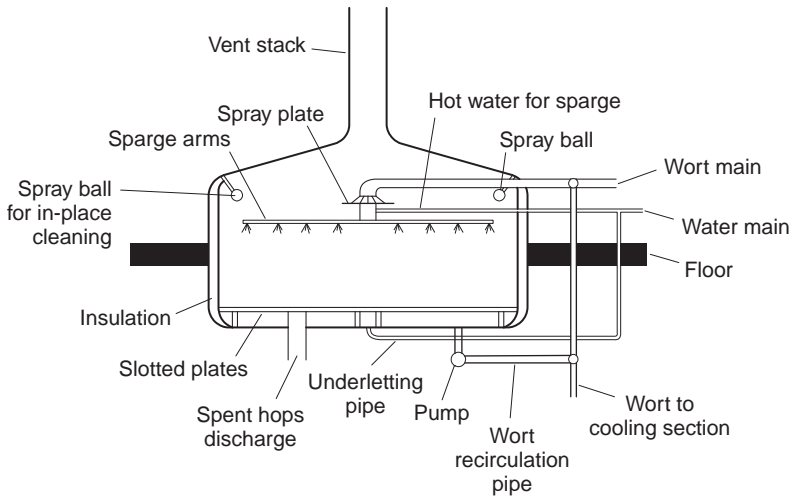

Fig. 10.18 A traditional British hop back, for separating whole hops from cast wort (Hough *et al.*, 1982).

were sparged with hot water from fixed sparge-rings, to recover entrained extract. The remaining trub settled in the coolships, when these were in use. The spent hops were discharged mechanically. A more refined device, used for separating hops, is the hop back (Fig. 10.18). In these the wort containing the remains of whole hops is spread over a false bottom in a vessel that, in later versions, is enclosed. The wort is withdrawn from below the plates, having slots of about 1.55 mm (0.06 in.) occupying 25–30% of the base and, at first, is returned to the top of the bed of hops that is formed. This filters off most of the hot break. When the wort is clear ('running bright') it is directed to the cooler. The process is comparatively slow. The vessel, which in modern designs is equipped for CIP, superficially resembles a mash tun, and indeed in some small breweries the mash tuns are used as hop backs.

To work well the bed of spent hops should be 30–60 cm (c. 1–2 ft.) deep; 15 cm (6 in.) is regarded as the minimum depth. As hopping rates have been reduced and the use of milled and pelleted hops has become commonplace, hop backs have become less common. Sometimes aroma hops are added to the hop back, to impart more 'hoppy character' to a beer. From the hop back, the clarified wort is transferred, either directly or after brief storage in a buffer tank, to the cooling system. To recover the wort retained in the spent hops these are sparged with hot water (typically 8 l/kg spent hops; about 0.8 gal./lb.). Finally, the drained hops are removed. Spent hops may be disposed of with the spent grains. Cattle accept the grains/hops mixture. Cleaning may take place after every brew or after several brews.

Hop separators, (Fig. 10.19), drain the hops over a strainer, carry them forward and then sparge them and compress them with either a screw or a belt conveyor press, squeezing out residual liquid, before the spent hops are discharged. Separators do not separate most of the trub from the wort, and so trub removal has to be achieved in a separate operation.

Increasingly hop powders, pelleted powders and extracts are used, and with these hop backs and separators cannot be employed. In these cases the wort may be clarified by hot filtration, by centrifugation, by sedimentation in a coolship or in a more modern settling tank. But the most commonly used device in newer breweries is the whirlpool tank or the

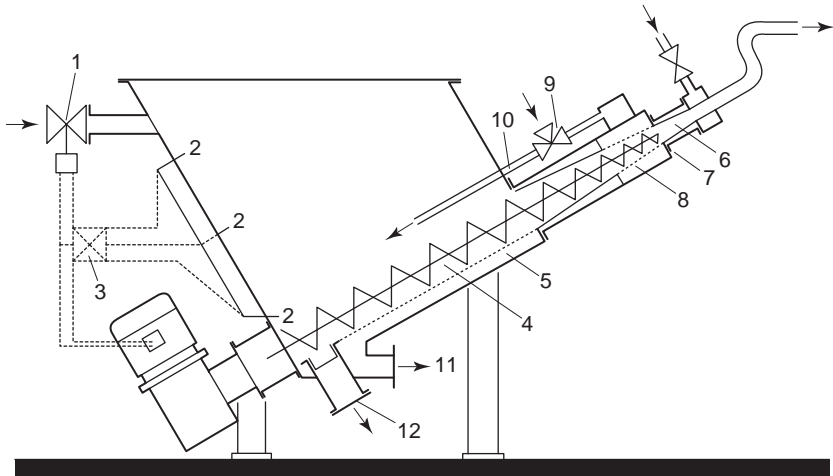

Fig. 10.19 A hop separator (Hough *et al.*, 1982, courtesy of A. Ziemann, GmbH). 1. Valve; 2. Level control electrodes; 3. Level controller; 4. Helical screw conveyor; 5. Sieve/strainer; 6. Compression chamber, where the hops are squeezed. 7. Fasteners; 8. Wort receiver under the second strainer; 9. Three-way valve (wort return and sparge water); 10. Return pipe; 11. Wort discharge; 12. Clean-out valve. Spent hops are discharged at the top.

combined copper (or kettle)/whirlpool. Filtration of the hot wort may be carried out using vertical, horizontal or candle filters employing kieselguhr or Perlite filter aids. Filtration gives exceptionally clear worts, but wort losses can be significant, it is difficult to maintain sterility and there are the costs of purchasing the filter aids and disposing of the used aid and sludge. Coolships are now rarely or never used although their shallow liquid layers allowed effective sedimentation and wort clarification. Wort losses and the risks of microbiological contamination were high.

The logical successors to coolships are sedimentation tanks (Fig. 10.20; Haecht, van *et al.*, 1990; Rehberger and Luther, 1994; Kunze, 1996; Vermeylen, 1962; Versteegh, 1989). These may have flat or conical bases and the sides of the tanks, which are generally cylindrical, may or may not be cooled by water in wall jackets. If cooling water is used it is itself heated and is retained for use. The vessels are enclosed and have vapour-escape stacks. Usually each vessel is filled from above (although in modern vessels bottom filling, to minimize oxygen pick-up and wort oxidation, would be expected) and is allowed to stand for about one hour, while solids in suspension progressively sediment. Wort is drawn from the top of the liquid, which clarifies first, using a hinged tube supported by a float. The turbidity of the wort that is collected is continuously monitored and if the value rises too much collection is slowed or stopped. The trub and hop fragments form a sloppy, 'turbid wort' that is collected and processed separately. There has been a proposal to cool the edge of the surface of the resting wort by evaporation, to encourage the downward flow of the wort by the vessel wall, across the base of the vessel, where precipitated materials accumulate, and upwards in the centre (Versteegh, 1989). The result claimed is a conical deposit of material in the middle of the flat base of the vessel analogous to that obtained in whirlpool vessels (see below).

Sometimes the hot wort is clarified by centrifugation in a decanter or a wort-clarifying centrifuge. These devices may also be used for wort recovery from wet trub samples. It is desirable, particularly if the wort is heavily hopped, to pre-treat it by passage through a rotary brush strainer and a hydrocyclone, to remove some of the hop solids and abrasive

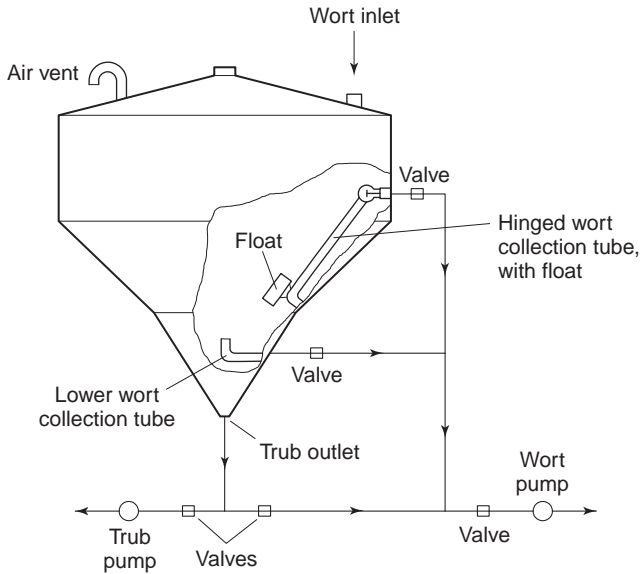

Fig. 10.20 An empty hot wort settling tank (after Rehberger and Luther, 1994). After a period of settling clear wort is drawn from the top, through the floating, hinged arm. At the end of the settling period the last of the clear wort is collected from the lower collection point and then the trub, mixed with wort, is also drawn off.

materials, before it enters the centrifuge. Modern centrifuges discharge collected solids automatically, they give good wort recoveries (losses of $< 0.3\%$ are achievable), they are automatically cleaned and can be operated under aseptic conditions. Little air can enter, so the risks of oxidation are minimized. However, they are expensive to buy and maintain.

The devices most often installed for hot wort clarification in modern breweries are whirlpool tanks or copper (kettle)-whirlpools. The whirlpool was first introduced in Montreal in 1960 (Hudston, 1969). Sometimes whole hops have been used with these vessels, but usually powdered or pelleted hops or hop extracts are used. A whirlpool consists of a vertical, cylindrical vessel, with a preferred height/width ratio of 0.7–0.8/1. Hot wort is injected tangentially, at about 30° to the tangent to the vessel wall, often at a rate of about 3.5 m/s. Sometimes injection is at about a third of the vessel height from the base, while in other cases the stream of wort is introduced nearer to the top or, in the cases of some kettle-whirlpools, at or above the surface. Pumps used to drive the wort from the copper to the whirlpool should exert minimal shear and not disrupt the trub. The tangential injection causes the wort in the vessel to rotate. The speed at which the injection should occur is contentious. If the initial rate of rotation is too slow it is possible to install a bypass circuit incorporating a pump that can withdraw and re-inject wort and so maintain or accelerate the rotation. After filling the vessel wort rotation gradually slows. During rotation the particles in the wort and the liquid are driven outwards by centrifugal force. The vertical pressure of the raised liquid at the edges tends to drive the liquid downwards and the particles strike the wall, move down with the liquid flow and tend to settle to the bottom (Fig. 10.21a). Wall friction slows the flow across the sides and across the base to the middle of the vessel. Deposited particles spiral towards the centre of the base.

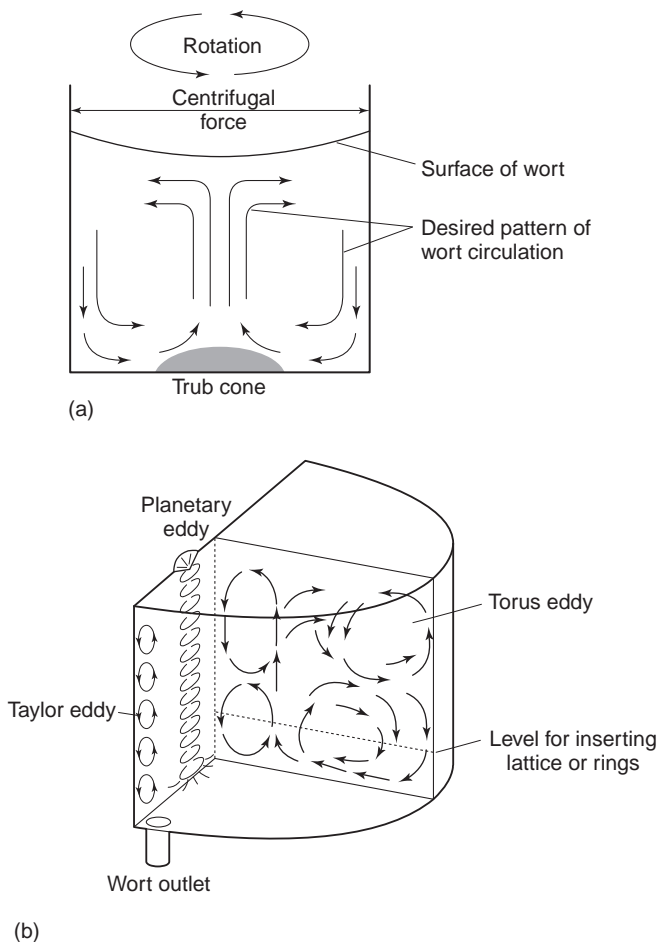

Fig. 10.21 Currents in whirlpool tanks. (a) The ideal flow pattern in a whirlpool. (b) Undesirable eddy currents that can occur and which interfere with trub separation. The most troublesome are the torus eddies, which may be checked by the insertion of a lattice or rings at the level indicated (after Denk, 1991).

In the centre of the tank the liquid rises, leaving solids deposited. The vessel is usually filled in 10–15 minutes and after 20–30 minutes the wort has cleared and the solids are deposited as a cone in the centre of the base of the vessel, surrounded by a clear, annular space. Wort is typically withdrawn from three exit points, often about half-way down the vessel, three-quarters of the way down and in the base of the vessel towards the side, where the clear zone should be. This allows the wort to be drawn off at successively lower levels as it clears. Its turbidity is generally monitored automatically. One or more of the upper take-off points may withdraw wort tangentially to support the rotary motion. Sometimes new whirlpools do not work in a satisfactory way and must be modified. Empirical and theoretical studies have improved the situation. Problems arise quite separately from the design of the whirlpool and/or how it is operated and from problems with the trub caused by factors in the brewing process, which operate before the wort enters the whirlpool. In attempts to improve whirlpool performance a large number of types of vessel bases have been tried, including flat and level or slightly inclined (with or

without central ‘cups’, or sumps of various sizes or a circumferential gully), inverted cones and conical bases (Andrews, 1988; Andrews and Axcell (private communication); Denk, 1991, 1994, 1998; Wilkinson, 1991 a, b).

One problem is that secondary eddies in the wort can disrupt the desired flow pattern and impede the sedimentation of the trub and hop residues (Fig. 10.21b). Two solutions have been proposed; first the installation of an annular, horizontal metal grid or, secondly, a set of 4–5 circular metal rings 25–60 cm above the base of the vessel. In each case these devices impede the flows of the secondary torus eddies and greatly improve the deposition of the trub. These devices are installed only if experience shows that they are needed. Sumps interfere with the desired flow pattern and encourage the collection of as much as 2% of the wort volume as trub wort, which must be processed separately to recover the entrained extract. The most popular configurations are now vessels with either flat bases, slightly inclined to the horizontal, to encourage drainage of the wort to the exit point at the outer edge of the clear zone, which surrounds the trub cone, or shallow, conical bases, with angles of about 30° (Fig. 10.22). In the first case, the cone remaining after the vessel has been drained should be dry. Subsequently it must be dislodged and dispersed, for example, with pulses of water from rotating, electrically driven jets, so that it drains to the lowest wort outlet. This cleaning should not be long delayed as the exposed trub cone can set hard in air. In the other case the trub, still with some wort, is withdrawn from the apex of the cone, and the wort is recovered by centrifugation.

Problems with the trub cone may be caused at earlier stages in the brewing process by using an abnormal grist, by having inadequate trub flocculation in the boil or by breaking up the trub through shearing the wort during pumping, by using a high-gravity wort which, because of its high density ‘buoys-up’ the trub, and so on. Attempts to improve cone formation have included the exclusion of air, additions of copper finings, nylon or PVPP powders, kieselguhr, bentonite and KMS (potassium metabisulphite). As the wort is withdrawn the trub cone is exposed and so is no longer supported by the buoyancy provided by surrounding wort. It then tends to slump and spread outwards and even break

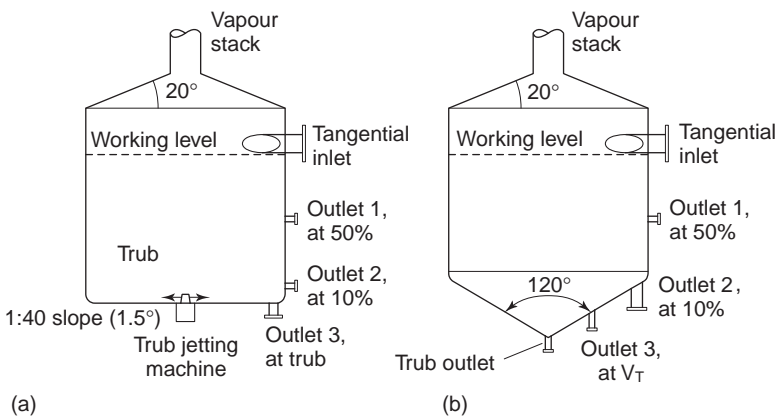

Fig. 10.22 Two patterns of kettle-whirlpools (Courtesy of Briggs of Burton, plc.). In each case boiling wort, driven by the thermosyphon effect generated in an external wort heater, is discharged tangentially above the surface of the wort. Volatiles readily escape with the vapour, and the wort rotates in the vessel driven by the incoming wort. (a) In this flat-based pattern direct wort recovery is favoured. The trub cone is drained and then, after wort recovery, is driven out with water jets. (b)

In this pattern, with a conical base, trub is recovered as a slurry in wort, which is normally recovered. This design favours high wort clarity.

up, so it may reach the lowest wort collection point. To counteract this, wort withdrawal is slowed when the trub cone is just exposed so that the trub is slowly drained and is exposed more slowly to the air, and the cone retains its shape better.

Kettle-whirlpools are of various types. Some are equipped with internal heaters and wort is withdrawn and pumped back via an injection entry to induce rotation in the liquid. This design requires the continuous use of a pump, with the equipment and maintenance costs and disrupting effects on the trub that this entails. The internal heater clutters the centre of the vessel. A better design uses an external heater that circulates the boiling wort using the thermosyphon effect. The boiling wort is returned to the top of the vessel at or above the wort surface and, being delivered through a tangential entry, drives the rotation of the liquid (Fig. 10.22). It can be operationally more convenient to have two copper-whirlpool vessels rather than a single copper and a single, separate whirlpool.

The wet trub produced by hot wort clarification contains, before washing, about 80% of wort. If this is sent to drain its high BOD and large amount of suspended solids give rise to high effluent charges. In addition extract is wasted. Disposal with the spent grains also wastes extract. If the brewing schedule permits it, extract is most easily recovered by transferring the trub to the mashing vessel or lauter tun making the next brew. Sometimes clear wort has been recovered from trub by filtration or by centrifugation (Hansen *et al.*, 1990). It is less costly to centrifuge the trub from a whirlpool than to omit the whirlpool and centrifuge all the wort. Cloudy wort has been obtained by vibrating screen filtration of trub, (Fig. 10.23), and this treatment has been used to pre-treat trub to provide the feed for complete clarification by cross-flow filtration (Maule *et al.*, 1989; Visscher *et al.*, 1991). The cross-flow filtration was carried out with ceramic filter units with notional $0.2\ \mu\text{m}$ pores. Their use increased the brewhouse yield by 1%. However, the units were easily fouled, reducing the filtration rate and extract recovery. To minimize this problem the re-circulating trub/wort was diluted in the later stages of treatment.

After the boil wort may remain in the whirlpool for up to an hour before being cooled. During this warm period chemical changes continue. Some, like the isomerization of the

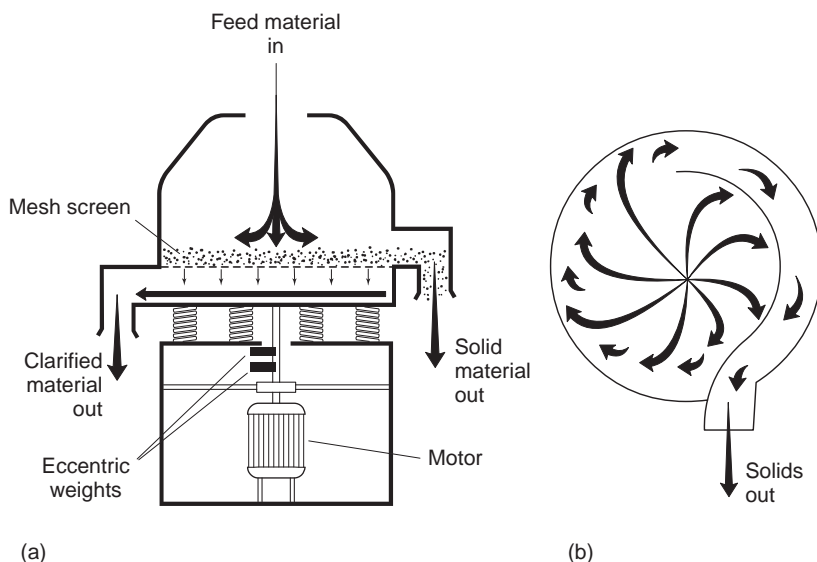

Fig. 10.23 (a) A vertical section of a vibrating screen filter and (b) the distribution and movement of solids on the filter surface as seen from above (Button *et al.*, 1977).

α -acids, are desirable but others, such as the generation of some volatile Maillard reaction products and DMS, may not be. The proposal to slow these changes by cooling the wort a little as it enters the whirlpool has already been noted. Another approach, already noted, is to 'strip' the wort of volatiles as it leaves the whirlpool, just before it is delivered to the cooling system. This has been achieved in different ways, for example, by spraying the wort into a vacuum chamber, by thin-film evaporation or by steam-stripping. Similar effects occur in the expansion/cooling chambers in high-temperature, continuous wort boiling (Section 10.5).

10.9 Wort cooling

After clarification the hot wort must be cooled to the temperature at which it is pitched (inoculated) with yeast. Traditionally this is about 15–22 °C (59–71.6 °F) for ales and 6–12 °C (42.8–53.6 °F) for lagers, but other temperatures are used. The cooling should be carried out rapidly and under aseptic conditions to stop chemical reactions continuing and to minimize chances of growth of any contaminating microbes. As the wort cools it becomes hazy as a cold break forms. This may or may not be removed (Section 10.10). In addition the wort must be charged with oxygen to an appropriate level (Section 10.11; Chapters 11 and 12). In modern breweries the heat from the hot wort is partly recovered in hot water.

The oldest coolers were the open, horizontal coolships, (Section 10.8), in which the wort was held in rectangular hardwood, copper, iron or aluminium trays in a shallow layer of, say, 15–25 cm (c. 6–10 in.), for as long as 12 hours, to cool, to pick up oxygen from the air and to deposit suspended materials, including hop fragments, hot break and some cold break. Ideally, the room holding the coolship had a curved ceiling designed to prevent condensation dripping into the wort and, in later times, was ventilated with sterile air (Hind, 1940; Sykes and Ling, 1907; Vermeyley, 1962). In practice coolships were difficult to keep clean and free from microbiological contamination, they took up much space and wort losses were high. In some cases cooling was accelerated by passing cold water through pipes placed on the base of the coolship, an arrangement that accelerated cooling, but with the added disadvantage of making the equipment awkward to clean.

The introduction of vertical coolers was a substantial advance, since they were compact, easier to clean, and cooled the wort comparatively rapidly. The wort was introduced to a trough at the top, from which it trickled down as a thin film over a series of horizontal tubes within which cold water flowed upwards, in a counter-flow. The tubes might be of various cross-sections or have projections on them designed to direct the flow of the wort and to increase the area of the heat-transfer surfaces. At the base of the cooler the wort was collected in a trough and piped to a fermenter. The wort was aerated in this process, but the cold break was not removed.

Sometimes wort is cooled, in closed shell and tube coolers, by passing it down through stainless steel tubes, which are successively cooled by air in the upper part, water in the central part and refrigerant in the lower part. Sterile air is injected into the base and rises up the tubes in a counterflow to the wort. A unit able to cool 450 hl/h (275 brl/h) would be about 7 m (23 ft.) tall and 2 m (6 ft. 6 in.) wide (Hough *et al.*, 1982). By far the most common coolers are plate heat exchangers (paraflows), which are compact, efficient and versatile. Being enclosed microbes are excluded, and cleaning and sterilization are simple. In these coolers numerous stainless steel plates are suspended vertically from a strong metal frame and are clamped together (Fig. 10.24). The numbers of plates can be

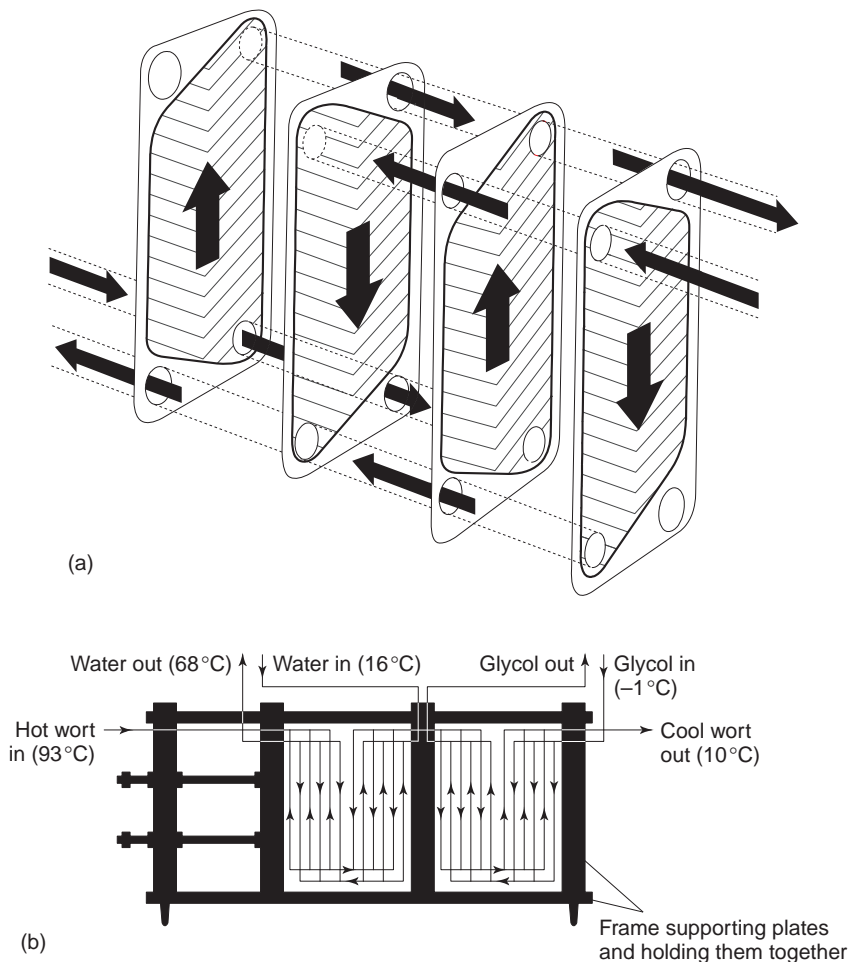

Fig. 10.24 (a) The principles of a plate and frame heat exchanger, indicating the movement of the liquid to be cooled and the counterflow of the cooling refrigerant (Hough *et al.*, 1982). (b) The flows in a two-stage cooling system (after Hough, 1985). In the first stage wort is cooled by a counterflow of water, which is heated in the process. In the second stage the wort is cooled further by a chilled glycol refrigerant.

varied and, as a result, so can the exchangers' cooling capacity. The plates are indented with complex patterns and have four holes in the corners. The edges of the plates and the holes are rimmed with rubber gaskets so that when the plates are pressed together the gaskets seal, and a series of ducts and channels are formed. In operation the wort flows through one channel, across the stack, between two plates and out to another channel while cold water or refrigerant flows in the opposite direction ('counter-current') in alternating gaps between the plates. The indented patterns on the plates ensure turbulent flow and efficient heat exchange.

The coolants can be supplied in various ways. For example, water should be the first so that it can be heated, to 70°C (158°F) or more, and used around the brewery. Part way through the cooler, cooling may be supplied by chilled water or a glycol, ammonia or an alcohol refrigerant. The arrangement used will be decided, in part, by the final wort

temperature required. However, if a coolant other than water is used care is needed to regularly check the integrity of the plates and seals, so that there is no possibility that a coolant can leak and contaminate the wort. Coolers must be regularly cleaned, to remove scale and fouling, and must be checked for leaks. The plates are mounted to allow ease of separation and replacement. Sometimes sterile air or oxygen is injected into the wort in the cooler to take advantage of the turbulent flow that encourages the gas to dissolve.

10.10 The cold break

As the wort cools it becomes cloudy as the cold break or trub separates from solution. This material contains about 50% protein, 15–25% polyphenols and 20–30% of wort carbohydrates (see Chapter 9). Unlike the hot break this material does not flocculate, and occurs as small particles, $< 1 \mu\text{m}$, in amounts reported to be 40–350 mg/l. In the past there was much interest in the temperatures at which cold break formation began and whether it occurred more rapidly when cooling was rapid or slow (Hough *et al.*, 1982). The importance of cold break in brewing is disputed. There may be two main reasons for this; firstly the break in worts from different grists may have significantly different properties and, secondly, in some cases the cold break may be mixed with hot break that was not completely removed and so effects attributed to the cold break are, in fact, due to residual hot break. Some have reported that cold break has no influence on fermentation rate or beer analyses while others report that cold break accelerates the fermentation rate very significantly (Crompton and Hegarty, 1991; Dickel *et al.*, 2002; Narziss *et al.*, 1971; Rehberger and Luther, 1994).

Zinc ions and/or unsaturated fatty acids in the break could stimulate yeast multiplication in zinc-deficient or poorly oxygenated worts (Chapters 11 and 12). ‘Excess’ cold break may confer off-flavours to beers, it will contaminate the yeast crop and it may confuse the control of pitching rate, cause poor fining, and accelerate the fermentation rate. Even where cold break removal had no measurable effects on the brewing parameters, beers made from break-free worts were preferred (Narziss *et al.*, 1971). Total removal of the cold break is not possible because formation continues during fermentation and beer cooling, indicating a relationship with chill haze. The amount of break formed is temperature dependent (Fig. 10.25). In New Zealand wort is often cooled to 0°C (32°F), or even less so that it contains ice slush. This allows storage for 24–48 h, for example over the weekend. The trub is separated by kieselguhr filtration, giving haze-resistant beer (Coutts *et al.*, 1955). It seems that pale, fine-flavoured beers benefit from the removal of some of the cold break, but in fact many breweries no longer remove any. Cold break removal may be by kieselguhr or perlite filtration, centrifugation, sedimentation or flotation. Filtration removes most of the break, but the method of choice is flotation. This is usefully combined with yeast aeration and pitching, the presence of yeast minimizing the chances of microbiological infection (Kunze, 1996). Cool wort, often freshly pitched with yeast, is held in a suitable vessel and very fine bubbles of sterile air are introduced at the base. These slowly rise to the surface collecting trub particles as they rise. Initially a thick layer of foam forms, but after some hours this subsides to a layer 5–10 cm (c. 2–4 in.) thick. The thickness of the layer of foam may be reduced by carrying out the operation against a counter-pressure. After about eight hours the wort is withdrawn from beneath the layer of compacted foam, which is sufficiently coherent to remain in the vessel. Wort loss is 0.2–0.4% and 60–65% of the cold break is removed. This procedure, in effect, includes aeration and the first fermentation stage.

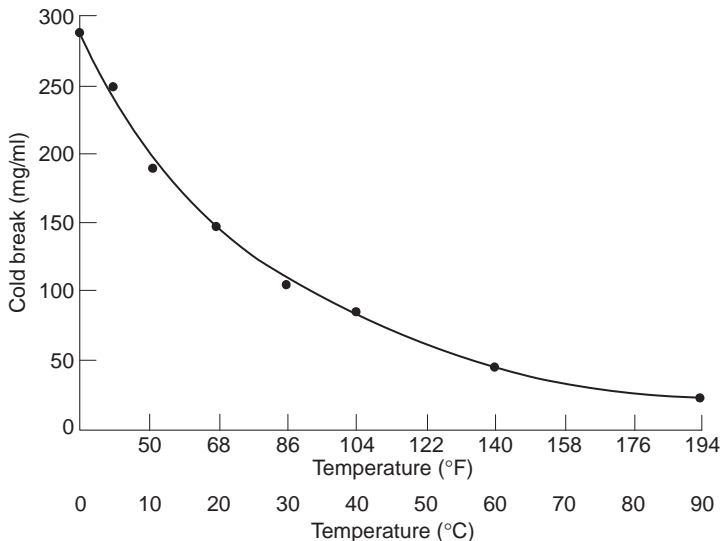

Fig. 10.25 The amounts of cold trub (break) formed in a particular wort at various temperatures (Hough *et al.*, 1982).

10.11 Wort aeration/oxygenation

In the initial stage of 'fermentation' the freshly pitched yeast needs to be in wort that contains dissolved oxygen. The concentration of oxygen required is critical, and depends on the wort, for example, the availability of sterols and unsaturated fatty acids, and the variety and history of the yeast (Chapters 11 and 12). In the past it seems that saturating wort with oxygen from air (approx. 21% O₂) was sufficient, but now saturation with pure oxygen is often required. It is surprisingly difficult to dissolve oxygen quickly in aqueous solutions. At equilibrium the amount of gas dissolved at a chosen temperature is proportional to the partial pressure of the gas above the liquid. Although solubilities are often reported at a standard atmospheric pressure, (equal to that at the base of a column of mercury 760 mm (29.92 in.) high at 0°C (32°F), at sea level at 45° latitude), decreasing or increasing this pressure will proportionally change the equilibrium concentration of the gas in solution. Atmospheric pressure is always fluctuating. As the temperature increases, so the amount of oxygen in solution, in equilibrium with air or pure oxygen, declines (Table 10.4).

Dissolving substances (salts, sugars, etc.) in water reduces the amount of gas that can be dissolved. Wort is a strong solution of a mixture of substances and so the solubility of oxygen in wort is less than in pure water (Table 10.4), and the stronger, more concentrated the wort the less oxygen will dissolve in it under a fixed set of conditions. Wort may be injected with air or oxygen at the inlet to the cooler, part-way through the cooler (Section 10.9), or after the cooling process is complete. Adding the gas to hot or warm wort allows the oxidation of wort components, causing flavour changes and darkening, which are usually undesirable. However, adding the gas to the hot wort means that the sterility of the gas is not so critical as microbes will be killed at the elevated temperatures. Air or oxygen added to cooled wort must have been sterilized, either by filtration, e.g., through sintered metal with pores < 0.45 μm, or by exposure to ultraviolet radiation. A gas must also be pure and be free from oil from a compressor pump.

Table 10.4 The solubility of oxygen (mg O₂/l) from the air in water or wort at different temperatures and from pure oxygen gas, all at a standard atmospheric pressure (data of Krauss, 1967). Compare with Appendix A.12.

Temperature		From air		From oxygen
(°C)	(°F)	Water	Wort (12%)	Water
0	32	14.5	11.6	69
3	37.4	–	–	64
5	41	12.7	10.4	61
8	46.4	–	–	56
10	50	11.2	9.3	54
15	59	10.0	8.3	48
20	68	9.9	7.4	–

The rate of dissolution of a gas in liquid depends on the pressure, the thoroughness of mixing and the area of the gas/liquid interface. Consequently, it is most efficient to direct a stream of very fine gas bubbles, under pressure, into a turbulent flow of wort. Devices used for aeration/oxygenation include sintered metal or ceramic candles, which release clouds of very fine bubbles into the base of a vessel or into a flowing stream of wort and are strong but which are difficult to keep clean, and centrifugal mixers which are very efficient but are expensive (Kunze, 1996). Devices based on the Venturi tube principle, which aerate/oxygenate cooled wort while flowing to a fermenter, are common. The flowing wort comes to a restriction in the pipework, which causes it to accelerate and the pressure to drop. At this point fine bubbles of air or oxygen are introduced into the liquid either from a fine nozzle, discharging into the stream of wort, or from fine perforations or sintered material in the tube wall. The clouds of bubbles are carried forward into the next section where the pipe abruptly expands, the flow slows and so the pressure rises and the flow becomes turbulent, conditions which favour the rapid solution of the gas. Sometimes the pipework downstream from the gas injection point contains inserts of metal ‘tapes’ or net-like units that act as mixers, creating turbulence in the wort flow.

In modern plant the dissolution of added oxygen is nearly complete. Oxygenation is automatically controlled, the rate of supply of gas is continuously monitored, for example, by measuring the flow rate or the decline in weight of gas cylinders. Alternatively, mass flow meters may be used. Sometimes oxygen is added to the first part of the wort flow and yeast is added to the second part. The level of dissolved oxygen, (really the equilibrium partial pressure), is usually monitored continuously by a membrane-covered oxygen electrode or cell.

10.12 References

- ANDREWS, J. M. H. (1988) *Ferment*, **1** (3), 47.
 ANDREWS, J. M. H. (1992) *Proc. 22nd Conv. Inst. of Brewing (Australia and New Zealand Section), Melbourne*, p. 65.
 ANDREWS, J. M. H. and AXCELL, B. C. Private communication.
 ANON. (1994) *J. Inst. Brewing*, **100**, 130.
 BENITEZ, J. L., FORSTER, A., DE KEUKELEIRE, D., MOIR, M., SHARPE, F. R., VERHAGEN, L. C. and WESTWOOD, K. T. (1997) *EBC Manual of Good Practice: Hops and Hop Products*. 185 pp. Nürnberg, Getränke-Fachverlag Hans Carl.
 BOER, F. P. DE (1991) *Eur. Brew. Conv. Monograph-XVIII. EBC Symposium; Wort boiling and clarification. Strasbourg*, p. 193.
 BONACCHELLI, B., HARMEGNIES, F. and GIL, R. T. (2001) *Proc. 28th Congr. Eur. Brew. Conv., Budapest* (CD, paper 24; p. 235).

- BOYES, R. (1993) *Brewers' Guard.*, **122** (3), 23.
- BRAEKELEIRS, R. and BAUDUIN, C. L. (2001) *Proc. 8th Brew. Conv., Inst. of Brewing (Central and Southern African Section)*, Sun City, p. 36.
- BUTTON, A. H., STACEY, A. J. and TAYLOR, B. (1977) *Proc. 16th Congr. Eur. Brew. Conv., Amsterdam*, p. 377.
- CHANTRELL, N. S. (1983) *Proc. 19th Congr. Eur. Brew. Conv., London*, p. 89.
- CHANTRELL, N. S. (1984) *MBAA Tech. Quart.*, **21** (4), 166.
- CLARKE, M. H. M. and KERR, R. A. (1991) *Eur. Brew. Conv. Monograph-XVIII. EBC Symposium: Wort boiling and clarification*, Strasbourg, p. 139.
- COUTTS, M. W., RICKETTS, J. and SELKIRK, R. C. (1955) *Proc. Conv. Master Brewer's Assoc. Amer.*, p. 20.
- CROMPTON, I. E. and HEGARTY, P. K. (1991) *Proc. 23rd Congr. Eur. Brew. Conv., Lisbon*, p. 625.
- DENK, V. (1991) *Eur. Brew. Conv. Monograph-XVIII. EBC Symposium: Wort boiling and clarification. Strasbourg*, p. 155.
- DENK, V. (1994) *Ferment*, **7** (5), 299.
- DENK, V. (1998) *Brauwelt Internat.*, **16** (1), 31.
- DICKEL, T., KROTTENTHALER, M. and BACK, W. (2002) *Brauwelt Internat.*, **20** (1), 23.
- DYMOND, G. and DJURSEV, O. (1994) *Brew. Distill. Internat.*, **25** (4), 16.
- FOHR, M. and MEYER-PITTOFF, R. (1998) *Brauwelt Internat.*, **16** (4), 304.
- FORREST, I. S., SKRGATIC, D., COKER, I. A. J. and HEAP, J. (1993) *Proc. 24th Congr. Eur. Brew. Conv., Oslo*, p. 493.
- FORTUIN, B. (1995) *The Brewer*, **81**, 443.
- GRASMAN, R. and VAN EERDE, P. (1986) *Proc. 19th Conv. Inst. Brewing (Australia and New Zealand Section)*, Hobart, p. 161.
- HACKENSELLNER, T. (1999) *Brauwelt Internat.*, **17** (6), 495.
- HAECHT, J.-L., VAN, DE BRACKELEIRE, C., DUFOUR, J.-P. and DEVREUX, A. (1990) *Eur. Brew. Conv. Monograph-XVI. EBC Symposium, 'Separation Processes', Leuven*, p. 96.
- HALL, R. D. and FRICKER, R. (1966) *Proc. 9th Conv. Inst. Brewing (Australia and New Zealand Section)*, Auckland, p. 45.
- HANCOCK, J. C. and ANDREWS, J. M. H. (1996) *Ferment*, **9** (6), 344.
- HANSEN, N. L., LUND, M. and OLSEN, N. O. (1990) *Eur. Brew. Conv. Monograph-XVI. EBC Symposium 'Separation Processes', Leuven*, p. 84.
- HERRMANN, H. (1985) *Brew. Distill. Internat.*, Mar., p. 32.
- HERRMANN, H. (1998a) *The Brewer*, **84** (1005), 333.
- HERRMANN, H. (1998b) *Ferment*, **11** (1), 36.
- HERRMANN, H. (1999) *Ferment*, **12**, Feb/Mar., 36.
- HIND, H. L. (1940) *Brewing Science and Practice*, **II. Brewing Processes**. London, Chapman and Hall, pp. 507-1020.
- HOUGH, J. S. (1985) *The Biotechnology of Malting and Brewing*. Cambridge University Press. 169 pp.
- HOUGH, J. S., BRIGGS, D. E., STEVENS, R. and YOUNG, T. W. (1982) *Malting and Brewing Science. II. Hopped Wort and Beer*. London, Chapman and Hall, pp. 389-914.
- HUDSTON, H. (1969) *MBAA Tech. Quart.*, **6** (1), 164.
- KANTELBERG, B., WIESNER, R., JOHN, L. and BREITSCHOPF, J. (2000) *Brew. Distill. Internat.*, **31** (3), 16.
- KOLLNBERGER, P. (1986) *MBAA Tech. Quart.*, **23**, 126.
- KOLLNBERGER, P. (1987) *Brauwelt*, **127**, 254.
- KRAUSS, G. (1967) *Proc. 11th Congr. Eur. Brew. Conv., Madrid*, p. 35.
- KROTTENTHALER, M. and BACK, W. (2001) *Brew. Distill. Internat.*, **32** (3), 14.
- KROTTENTHALER, M., HARTMANN, K. and BACK, W. (2001) *Brauwelt Internat.*, **19** (6), 457.
- KUNZE, W. (1996) *Technology Brewing and Malting*. (Internat. edn, translated Wainwright, T.) Berlin, VLB, p. 254.
- LANGENHAN, R. (1995) *J. Inst. Brewing*, **101**, 230.
- LENZ, B., LANGENHAN, R., HERRMANN, H., KANTELBERG, B. C. and FELGENTRAEGER, W. (1991) *Proc. 3rd Sci. Tech. Conv. Inst. of Brewing, (Central and Southern African Section)*, Victoria Falls, p. 101.
- LUSTIG, S., KUNST, T. and HILL, P. (1997) *Proc. 21st Congr. Eur. Brew. Conv., Maastricht*, p. 341.
- MANGER, H.-J. (1998) *Brauwelt Internat.*, **16** (4), 320.
- MAULE, D. R. and CLARK, B. E. (1985) *Proc. 20th Congr. Eur. Brew. Conv., Helsinki*, p. 379.
- MAULE, D. R., STEAD, J. R. and CLARK, B. E. (1989) *Proc. 22nd Congr. Eur. Brew. Conv., Zurich*, p. 393.
- MICHEL, R. A. (1991) *Eur. Brew. Conv. Monograph-XVIII. EBC Symposium; 'Wort boiling and clarification'. Strasbourg*, p. 118.
- MIEDANER, H. (1986) *J. Inst. Brewing*, **92**, 330.
- MIEDANER, H. and NARZISS, L. (1986) *Eur. Brew. Conv. Monograph-XI. EBC Symposium; 'Wort Production'. Maffliers*, p. 80.
- MITANI, Y., SUZUKI, H., ABE, T., NOMURA, M. and SHINOTSUKA, K. (1999) *Proc. 27th Congr. Eur. Brew. Conv., Cannes*, p. 619.
- MORRIS, D. R. (1987) *Brew. Distill. Internat.*, **17** (3), 22.
- NARZISS, L. (1986a) *Eur. Brew. Conv. Monograph-XI. EBC Symposium; 'Wort Production'. Maffliers*, p. 98.

- NARZISS, L. (1986b) *Brauwelt*, **126**(32), 1419.
- NARZISS, L. (1992) *Die Bierbrauerei. II. Die Technologie der Würzbereitung*. (7th edn). Stuttgart, Ferdinand Enke. 402 pp.
- NARZISS, L. (1993) *Proc. 4th Sci. Tech. Conv. Inst. of Brewing, (Central and Southern African Section), Somerset West*, p. 195.
- NARZISS, L., KIENINGER, H. and REICHENDER, E. (1971) *Proc. 13th Congr. Eur. Brew. Conv., Estoril*, p. 197.
- NARZISS, L., MIEDANER, H. and SCHNEIDER, F. (1992) *Brauwelt Internat.*, **IV**, 346.
- ORMROD, I. H. L. (1986) *J. Inst. Brewing*, **92**, 131.
- REED, R. J. R. (1992) *Ferment*, **5**(2), 125.
- REHBERGER, A. J. and LUTHER, G. E. (1994) in *Handbook of Brewing* (Hardwick, W. A. ed.), New York, Marcel Dekker, p. 247.
- ROYSTON, M. G. (1971) in *Modern Brewery Technology*. (Findley, W. P. K. ed.). London, Macmillan and Co., p. 60.
- SCHU, G. E. (1995, Oct). *Brauwelt Internat.*, **13**(4), 316.
- SCHWILL-MIEDANER, A. and MIEDANER, H. (2002) *Brauwelt Internat.*, **20**(1), 19.
- SELDESCHLACHTS, D., VAN DER EYNDE, E. and DEGELIN, L. (1997) *Proc. 26th Congr. Eur. Brew. Conv., Maastricht*, p. 323.
- STIPLER, K. (2000) *Ferment*, **13**(1), 34.
- STIPLER, K., WASMUHT, K. and GATTERMEYER, P. (1997) *Brauwelt Internat.*, **15**(4), 358.
- SYKES, W. J. and LING, A. R. (1907) *The Principles and Practice of Brewing*. (3rd edn). London, Charles Griffin and Co., p. 496.
- UNTERSTEIN, K. (1992) *Brauwelt Internat.*, **10**(1), 65.
- VERMEYLEN, J. (1962) *Traité de la Fabrication du Malt et de la Bière*. **2**, pp. 861, 937. Gand. Assoc. Royale des Anciens Elèves de l'Institute Supérieur des Fermentations.
- VERSTEEGH, C. W. (1989) *Proc. 22nd Congr. Eur. Brew. Conv., Zurich*, p. 291.
- VISSCHER, H. J., TETTELAAR, M. E. and MARTENS, F. B. (1991) *Proc. 23rd Congr. Eur. Brew. Conv., Lisbon*, p. 649.
- VOLLHALS, B. (1994) *MBAA Tech. Quart.*, **31**(1), 1.
- WILKINSON, N. R. (1985) *Proc. 1st Sci. Tech. Conv. Inst. of Brewing (Central and Southern African Section), Johannesburg*, p. 188.
- WILKINSON, N. R. (1991a) *Eur. Brew. Conv. Monograph-XVIII. EBC Symposium; 'Wort Boiling and Clarification'*. Strasbourg, p. 100.
- WILKINSON, N. R. (1991b) *Ferment*, **4**(6), 388.

11

Yeast biology

11.1 Historical note

The abilities of *Saccharomyces* yeast to leaven dough in baking and generate ethanol for beverage production have been utilized by mankind for several millennia, albeit for most of that time, unwittingly. The consumption of alcoholic beverages is common to all civilizations. Production of the earliest drinks was probably serendipitous since natural sources of sugars are invariably contaminated with yeast. Metabolism of sugars by *Saccharomyces* yeasts results in the formation of ethanol and carbon dioxide even under aerobic conditions. The mind-altering effects of ethanolic beverages must have provided the primary motive for their continued consumption and a powerful impetus for empirical development of a controlled process of production. Coincidentally, such drinks would have been nutritious and a useful means of sanitizing potentially dangerous water supplies.

Brewing of beer has its probable origins in the Middle East at some time between 6000 and 8000 BC, where it apparently developed in tandem with organized agriculture (Corran, 1975). It seems that the use of cereals for baking and brewing developed simultaneously. Clearly, this must also have included the discovery of malting and the use of yeast for leavening of dough and fermentation. These activities became large-scale undertakings, for example, it has been reported that in ancient Mesopotamia 40% of cereals were cultivated purely for brewing (Corran, 1975).

Brewing spread from the Middle East to become the dominant alcoholic beverage of northern Europe. Thus, Tacitus commented that beer was the common drink in Germany at the time of the Roman Empire (King, 1947). It was from old German that the word yeast arose, probably from *gischen* descriptive of the foaming or frothing during fermentation. Pliny described the use by the Gauls for leavening of dough of 'foam' obtained from beer fermentations (King, 1947). It is implicit in this etymology that the importance of yeast to brewing and baking was appreciated in historical times although its vital nature was unrecognized. For example, in medieval England the yeast crop resulting from fermentation was known as *godisgood* (Forget, 1988). Nevertheless, the earliest manifestation of the German *Reinheitsgebot* or beer purity laws introduced to Bavaria in 1493 by Duke Albrecht IV stipulated the exclusive use of hops, malted barley

and water for brewing. Yeast was not included as an ingredient since it was unknown (Narziss, 1984).

The first description of individual yeast cells was published in 1680 by Antonie van Leeuwenhoek (Chapman, 1931). Using a primitive microscope he recorded the appearance of yeast flocs in fermenting wort and modelled the same in wax. He also noted the formation of gas bubbles but did not appreciate that this was a by-product of yeast metabolism. The realization of the biological nature of fermentation forms the basis of the development of modern biochemistry and microbiology. Early alchemists observed the vigorous gas formation that accompanied the metabolism of wort by yeast and coined the term fermentation from the Latin *fevere*, to boil. The alchemist view of fermentation was that this was a process of active separation. Thus, ethanol was present but could not be detected until the 'impurities' yeast and carbon dioxide were removed (Florkin, 1972).

Gay-Lussac in 1810 established the stoichiometry of ethanolic fermentation by demonstrating that two molecules each of ethanol and carbon dioxide devolved from each molecule of sugar consumed. He suggested that fermentation was initiated by exposure to oxygen since heated foodstuffs in sealed containers spoiled only when air was admitted. He also noted that spoilage could be stopped by further heating but failed to form the conclusion that there was a heat-labile component present. He suggested that heat changed the 'ferment' to an inactive form in which it was impervious to the stimulating effects of oxygen. Yeast was not considered to play any part in fermentation on the basis of insolubility.

Undoubtedly, early practitioners of brewing and baking appreciated the essential requirement for yeast in fermentation by dint of empirical observation. Later incarnations of the *Reinheitsgebot* included yeast as an ingredient in beer making based on the observations that addition to wort of some of the crop from a previous fermentation gave a more consistent process (Narziss, 1984). The role of yeast in fermentation and its vital nature was established independently by the Germans, Theodor Schwann (1837) and Friedrich Traugott Kützing and a Frenchman, Charles Cagniard-Latour (1836). Both Kützing and Cagniard-Latour used direct microscopic observation to describe yeast cells. The latter recorded yeast proliferation by the formation of buds and both deduced that the cells were living and had an active role in fermentation.

Schwann's investigations were directed towards disproving the theory of spontaneous generation of life. He demonstrated that a meat infusion did not putrefy if heated. Furthermore, the onset of putrefaction subsequently brought about by the admission of air was prevented if the latter was first heated. He was able to demonstrate that heating of air did not change its essential character since it could still sustain the life of a frog. This disproved the earlier assertions of Gay-Lussac. Schwann also made microscopic observations of growing yeast cells, which he termed *Zuckerpilz*.

Despite the observations of Schwann, the vital nature of yeast was not generally accepted until the work of Louis Pasteur was published (Anderson, 1995). Pasteur studied optically active molecules, which he considered were produced only by living organisms. He isolated optically active amyl alcohol from fermentations and therefore assumed that the process must be animate. Pasteur extended the work of Schwann and demonstrated that putrefaction of foodstuffs occurred via contamination with air-borne micro-organisms. He showed that putrefaction did not occur in heated broth even with free access to air, provided that ingress of micro-organisms was prevented by the ingenious design of his 'swan-necked' flasks.

Pasteur made careful microscopic examination of beer fermentations, the results of which were published in his *Études sur la bière* of 1876. He observed the growth of brewing yeast cells and demonstrated that these were responsible for fermentation. He also recorded the symptoms of several specific 'diseases' of fermentation and identified the causative microbial contaminants associated with each. Thus, he was instrumental in pointing out the necessity of adopting the highest standards of hygiene for successful brewing. He designed equipment that fulfilled this requirement. Central to his recommendations was the realization that microbial growth on sugars or wort was via contamination and not by spontaneous generation. Furthermore, new microbial cells arose solely from similar parental cells. In order to reach these conclusions Pasteur developed methods for the sterilization of media and the preservation and propagation of microbial cultures.

Pasteur recommended the use of microscopy as an aid in production brewing. Others have pointed out that this instrument had already been adopted by several brewers prior to Pasteur's visits (Anderson, 1995). In any case by the early twentieth century, Jörgensen in the third edition of his treatise entitled *Micro-organisms and Fermentation*, published in English translation in 1900 (Jörgensen, 1900) described methods for assessing yeast 'health' by microscopic observation. Pasteur was comparatively indifferent to the nuances of cellular morphology of individual species. The ability to differentiate micro-organisms was largely dependent on the development of methods for isolating and propagating pure cultures. This was difficult using the liquid cultures employed by Pasteur.

The use of solid microbiological media on which pure cultures could be isolated from colonies derived from single cells was pioneered by the work of the medical bacteriologist, Robert Koch (1881). In 1883, Emil Hansen, working at the Carlsberg Foundation in Copenhagen, used similar techniques to isolate the first pure yeast culture. At the same time Hansen introduced the first modern apparatus for propagating yeast and the first pure culture of 'Carlsberg Yeast Number 1' was used successfully in commercial brewing (Curtis, 1971). The availability of pure cultures provided the means of elucidating the yeast life cycle. Hitherto, yeast cells had been considered to be merely phases in the life cycles of other organisms such as moulds, bacteria or even algae (Rose and Harrison, 1971). An assistant of Hansen, Schiønning reported the occurrence of a sexual phase in the yeast life cycle. This was confirmed in the 1930s when Øjvind Winge also working at the Carlsberg Foundation provided a full description of the yeast haplo- and diplophases.

As early as 1897, Büchner demonstrated the formation of ethanol and carbon dioxide from sugar using a cell-free extract of yeast, thereby providing the foundation for the development of modern biochemistry. Yeast has been used as a convenient experimental organism in many subsequent investigations. The zymologist, A. H. Rose, proposed in the introduction to the second volume of the first edition of *The Yeasts* (Rose and Harrison, 1971) the initiation of 'Project Y'. This suggested that yeast be used as a model eukaryotic organism in an integrated approach to the study of cell biology. This challenge has been taken up and the academic literature devoted to yeast in general and *Saccharomyces cerevisiae* in particular is now immense. Many of the discoveries in cell biology, physiology, biochemistry and genetics were made using yeast cells. Probably, *S. cerevisiae* is the most extensively studied cell. This has culminated in the sequencing of the entire genome of *S. cerevisiae*, the first species for which this has been accomplished (Goffeau *et al.*, 1996).

11.2 Taxonomy

Taxonomy is the science of the classification of organisms. Using criteria such as morphology, life cycle, immunological properties, biochemical capabilities and genetic analysis, organisms are grouped into hierarchies of relatedness and difference. Systems of taxonomy indicate functional and evolutionary relationships between groups of organisms and they provide a framework for identifying unknown types. Taxonomy has practical importance in brewing. It allows the identification of proprietary yeast strains and the ability to distinguish these from contaminants such as wild yeasts.

Each group is termed a taxon. In descending order of hierarchy the main taxonomic groups are kingdom, division, class, order, family, genus, species and strain. Of these, the last three are of most practical interest. A genus represents a group of organisms, which are closely related in evolutionary terms. Usually this is accompanied by structural and functional similarities. Organisms are grouped into species usually based on the ability to interbreed. In the case of yeast, many of which have no sexual cycle, this definition is of limited value. Where organisms are restricted to asexual reproduction, placement within a species has to be based on other criteria, the most reliable being that of similarity of genotype. Strains are clones derived from a single parental cell. For example, in the case of yeast a cell line propagated from a single colony of a pure culture. In this case, it is assumed that the colony was formed from asexual reproduction of a single parental cell.

Organisms are described using a binomial nomenclature of genus name followed by species name. Both are Latin terms and by convention in typescript are italicized, the genus name being capitalized and the species name in lower case. After introducing the complete binomial name, the genus name may be abbreviated thereafter. Thus, brewing yeasts are classified as *Saccharomyces cerevisiae* (*S. cerevisiae*). Binomial names may be descriptive of the appearance of the organism, its mode of growth, habitat or a Latin derivation of the name of the discoverer. The genus name, *Saccharomyces* translates as 'sugar fungus', referring to the habitat in which the organism is usually to be found and the fact that it is a member of the Fungi. The species name *cerevisiae* derives from the Latin for beer as in *ceres* (= grain) and *vise* (= strength).

Genus and species names are subject to stringent rules. In the case of yeast, these fall under the remit of the International Code of Botanical Nomenclature (Greuter *et al.*, 1996). Strain names are chosen by the discoverer and conventions are comparatively lax. Commonly, they are named using codes, which are combinations of letters and numbers. Many are proprietary strains owned and jealously guarded by individual companies. The ability to identify individual strains and maintain them as pure cultures is of the utmost importance to those who use yeasts in industrial applications. Many thousands of industrial strains of *S. cerevisiae* are in existence. In this regard, the finer points of taxonomy are of somewhat academic interest only. Commonly, systems of nomenclature are used that are now not recognized by 'classical' taxonomists, however, they are retained because they are still of practical value. For example, see the discussion later in this section regarding the taxonomy of ale and lager brewing strains.

'Yeast' and *Saccharomyces* are not synonymous terms. This is perhaps understandable, bearing in mind the economic importance of *Saccharomyces* strains in brewing and baking and numerous papers reporting work in which *S. cerevisiae* has been used as a type eukaryotic cell. In fact, approximately 100 genera of yeast encompassing 700 species have been described (Kurtzman and Fell, 1998). Undoubtedly, many more remain unrecognized. Thus, some 70,000 species of fungi are currently recognized. It has been

estimated that approximately 1.5 million species of fungi may exist (Hawksworth, 1991). Undoubtedly many of these will be classified within the yeast group.

Kurtzman and Fell (1998) define yeasts as being fungi with vegetative states that reproduce by budding or fission resulting in growth that is predominantly in the form of single cells. Yeasts do not produce sexual states within or upon a specialized fruiting body. This definition is relatively imprecise since many fungi are dimorphic. During certain phases in their life cycles, such fungi adopt a yeast-like unicellular form and at others they take on a filamentous hyphal habit and develop into a mycelium.

Brewing yeast strains are ascomycetous types classified within the genus *Saccharomyces*. The precise taxonomy of the fungi in general and the *Saccharomyces* in particular is still subject to debate and continual revision. A current version is given in Table 11.1. At present, the genus *Saccharomyces* is divided into 14 species. The names of these species together with a key for their differentiation are shown in Table 11.2. The relationships between the 14 species assigned to the genus *Saccharomyces* have been the subject of intensive investigation. Based on homologies between ribosomal RNA and the mitochondrial genome it has been demonstrated that they can be arranged into smaller sub-groups (Vaughn-Martini and Martini, 1993; Piskur *et al.*, 1998; Montrocher *et al.*, 1998). The *Saccharomyces sensuo lato* group includes *S. dairensis*, *S. castelli*, *S. exiguus*, *S. servazzii*, *S. unisporus* and possibly *S. kluyveri*. This grouping is considered to contain species that are relatively heterogeneous.

The *Saccharomyces sensuo stricto* group contains *S. cerevisiae*, *S. pastorianus*, *S. bayanus* and *S. paradoxus*. As the nomenclature suggests these are much more closely related. Based on biochemical differences this group can be sub-divided into two subsets. *S. cerevisiae* and *S. paradoxus* can utilise melibiose, assimilate fructose via a facilitated transport mechanism and have a maximum growth temperature close to 37°C. Conversely, *S. bayanus* and *S. pastorianus* cannot utilize melibiose, have active transport systems for fructose uptake and are not capable of growth above 34°C.

All yeast species in the *Saccharomyces sensuo stricto* group, with the exception of *S. paradoxus*, are exploited commercially for the production of ethanol or in baking. It is suggested that these commercial yeast strains actually arose via selective processes in industrial situations. *S. paradoxus* alone is known to occur in natural habitats, whereas the others are rarely found so (Vaughn-Martini and Martini, 1993). *S. cerevisiae* is used for baking as well as brewing and in winemaking. *S. bayanus* strains are utilized solely for enological purposes, whereas *S. pastorianus* includes those strains originally classified as *S. carlsbergensis* and used as bottom-fermenting lager yeasts. It is possible, therefore that *S. bayanus* arose because of its ability to ferment at the relatively low temperatures of wine fermentations and to withstand high ethanol concentrations. Similarly, *S. pastorianus* strains were selected for their ability to bottom-crop in low-temperature lager fermentations.

The phylogenetic relationships between the *Saccharomyces sensuo stricto* highlight the undoubted differences between the individual species and support the arguments regarding their origins. Strains of the species *S. pastorianus* show a high degree of DNA homology with those of both *S. cerevisiae* and *S. bayanus*. Conversely, the strains of the latter two species show little similarity with each other. The genome of *S. pastorianus* strains is considerably bigger than that of *S. cerevisiae* and *S. bayanus*. It is proposed, therefore, that *S. pastorianus* is a hybrid species derived from *S. cerevisiae* and either *S. bayanus* or a closely related species, *S. monacensis* (Wolfe and Shields, 1997). The latter is now classified as *S. bayanus* but was originally considered to be *S. pastorianus*. Seemingly, the proportion of DNA contributed by *S. bayanus* to the *S. pastorianus*

Table 11.1 Classification of *Saccharomyces cerevisiae*

Taxon	Name	Comments
Kingdom	Fungi	
Phylum	<i>Ascomycotina</i>	Teliomorphic forms characterized by formation of ascospores enclosed within ascus
Sub-phylum	<i>Saccharomycotina</i> (syn. <i>Hemiascomycotina</i>)	
Class	<i>Saccharomycetes</i> (syn. <i>Hemiascomycetes</i>)	Single ascus not enclosed in ascocarp developing directly from zygotes
Order	<i>Saccharomycetales</i> (syn. <i>Endomycetales</i>)	Yeast-like cells, rarely developing hyphae
Family	<i>Saccharomycetaceae</i>	
Genus	<i>Saccharomyces</i>	Globose, ellipsoidal or cylindroidal cells. Vegetative reproduction by multilateral budding. Pseudohyphae may be formed but hyphae are not septate. The vegetative form is predominantly diploid, or of higher ploidy. Diploid ascospores may be formed that are globose to short ellipsoidal with a smooth wall. There are usually 1–4 ascospores per ascus
Type species	<i>S. cerevisiae</i>	

Table 11.2 Key to the species of *Saccharomyces* (taken from Kurtzman and Fell, 1998)

1 a. Maximum growth temperature above 30 °C	→ 3
b. Growth absent above 30 °C	→ 2
2 a. Sucrose, raffinose and trehalose fermented	<i>S. barnettii</i>
b. Sucrose, raffinose and trehalose not fermented	<i>S. rosini</i>
3 a. Ethylamine-HCl assimilated	→ 4
b. Ethylamine-HCl not assimilated	→ 6
4 a. Growth in the presence of 1000 ppm cycloheximide	<i>S. unisporus</i>
b. No growth in the presence of 1000 ppm cycloheximide	→ 5
5 a. Maltose, raffinose and ethanol assimilated	<i>S. kluyveri</i>
b. Maltose, raffinose and ethanol not assimilated	<i>S. spencerorum</i>
6 a. Maltose assimilated	→ 7
b. Maltose not assimilated	→ 10
7 a. Growth in vitamin-free medium	<i>S. bayanus</i>
b. No growth in vitamin-free medium	→ 8
8 a. D-mannitol assimilated, maximum growth temperature 37 °C or greater	<i>S. paradoxus</i>
b. D-mannitol not assimilated, maximum growth temperature less than 37 °C or variable at 37 °C	→ 9
9 a. Active transport mechanism for fructose present; maximum growth temperature 34 °C or lower	<i>S. pastorianus</i>
b. Active transport mechanism for fructose not present; maximum growth temperature variable	<i>S. cerevisiae</i>
10 a. Sucrose, raffinose and trehalose fermented	<i>S. exiguus</i>
b. Sucrose, raffinose and trehalose not fermented	→ 11
11 a. Growth in the presence of 1000 ppm cycloheximide	<i>S. servazzii</i>
b. No growth in the presence of 1000 ppm cycloheximide	→ 12
12 a. D-ribose normally assimilated; 8–10 chromosomes 600–3000 kilobases	<i>S. castellii</i>
b. D-ribose not assimilated, mostly single highly refringent ascospores on acetate agar; 8 chromosomes 400–2200 kilobases	<i>S. transvaalensis</i>
c. D-ribose normally not assimilated, 7–9 chromosomes 750–3000 kilobases	<i>S. dairiensis</i>

hybrids is greater than that made by *S. cerevisiae*. Nevertheless, chromosomes identical to those from both parents have been found co-existing in strains of *S. pastorianus* (Tamai *et al.*, 1998).

The taxonomic history of lager brewing yeast strains is chequered. The original descriptor for lager strains, *S. carlsbergensis* changed when these were re-christened as *S. uvarum*. Later the position became more clouded when the latter were assigned to the species *S. cerevisiae*. As discussed already, bottom-fermenting lager yeasts are again considered distinct from *S. cerevisiae* brewing strains and have been given the name *S. pastorianus*. This confirms what brewers have already decided, based on experience and observation, that ale and lager yeasts are different (Quain, 1986).

11.3 Yeast ecology

Yeasts are predominantly saprophytes and are widely distributed in nature where they are found in both terrestrial and aquatic habitats (Phaff and Starmer, 1987). In nature, yeasts

are primarily associated with higher plants, although the effects of rain and plant death inevitably means that soils act as a reservoir in which they can survive and be passed on to other hosts. Yeasts are rarely plant pathogens, instead they are commonly found on damaged fruits, in flowers and in exudates associated with wounds. The transfer of yeasts between plants is most often accomplished by the intermediary of insect vectors.

Natural populations of yeasts co-exist and compete with themselves and with other microbial species. Many yeast species are found in specialized plant habitats, which reflect their biochemical capabilities. Contrary to expectation, non-fermentative obligately aerobic yeast types are the most common. Typically, they occupy niches that provide a particular oxidizable substrate that they are capable of assimilating. Fermentative yeasts are able to take advantage of habitats where there is a source of sugar but no oxygen. Since such yeasts are facultative anaerobes the result of their own metabolic activity would be to remove oxygen from aerobic environments. They would then be able to continue to grow under conditions of anaerobiosis, whereas purely oxidative yeasts could not. In aquatic habitats containing a source of fermentable sugar the result would be that aerobic yeast would be restricted to the surface layers, possibly resulting in the formation of a pellicle. The population of fermentative yeasts would be capable of growth throughout the body of the liquid.

These observations are paralleled in brewing, for example, the growth of brewing yeast in a fermenter and the effects of some spoilage organisms in beer exposed to air. Some of the associations of yeasts and other micro-organisms have elements of symbiosis. For example, acetic acid bacteria are often found growing on the ethanol produced as a result of the metabolism of sugars by yeast. The bacteria remove ethanol, which can be toxic or even fatal to the yeast. The resultant acetic acid reduces the pH of the medium and inhibits the growth of other less acid-tolerant species. Some yeasts are able to occupy particular niches because of an ability to tolerate otherwise toxic products of the growth of other micro-organisms. For example, naturally occurring antibiotics such as cycloheximide produced by *Streptomyces griseus*, inhibit the growth of many yeast species but not others.

Other yeast types produce metabolites that are toxic to other potential yeast competitors. Some strains of *Saccharomyces cerevisiae* and representatives of the genera *Candida*, *Cryptococcus*, *Debaromyces*, *Hansenula*, *Kluyveromyces*, *Pichia* and *Torulopsis* produce so-called killer factors, which are fatal to other susceptible yeast species (Young, 1987). The killer factors, several distinct types of which are produced by individual yeast genera, are protein or glycoprotein in nature and are coded for either by chromosomal genes or in some cases by the RNA genomes of mycoviruses. They appear to bind to chitin in the wall of susceptible cells and cause death by destroying the transmembrane potential.

Yeasts are common contaminants of fruits and are potential spoilage organisms in extracted fruit juices, purées and concentrates. For example, in one study (Arias *et al.*, 2002) using orange juices some 99 different yeast strains, representing 11 genera were isolated. Some yeast species are capable of growth in media with very low water activity. These so-called osmotolerant species (Section 12.3.1) can cause spoilage of products such as bulk sugar syrups, particularly if the storage conditions allow condensation to form on the surface of the liquid.

Yeast strains used in industrial fermentations were originally isolated from nature. In rare cases, the natural microbial flora of the building in which the fermentation is conducted is used as the source of the inoculum, for example, in the production of traditional Belgian Lambic beer. In the modern brewery process, great care is taken to

ensure that contamination of worts and beers with foreign ‘wild’ yeast does not occur. Production strains of brewing yeasts are maintained as pure cultures and introduced into the brewery via a system of propagation. Such strains have been selected based on their possession of particular sets of desirable properties. In consequence, as discussed in the previous section of this chapter, brewing strains appear to be distinct from those found in nature.

11.4 Cellular composition

Yeast cells contain approximately 80% water. Thus, in pressed brewers’ yeast the ratio of wet to dry weight is roughly 5:1. Predictably, the most abundant element is carbon, which accounts for just under 50% of the dry weight. Other major elemental components are oxygen (30–35%), nitrogen (5%), hydrogen (5%) and phosphorus (1%). The total mineral content of yeast is approximately 5–10% of the cell dry weight. This fraction comprises a multitude of trace elements. The composition of some of these for three brewing and one bakers’ yeast strain is shown in Table 11.3. The most abundant classes of macromolecules are proteins (40–45% cell dry weight), carbohydrates (30–35%), nucleic acids (6–8%) and lipids (4–5%). The precise composition of each class of macromolecules within a given cell varies as a function of physiological condition and phase in growth cycle. There is considerable variation between different yeast species. For these reasons, it is not possible to provide other than the generalized composition given above. The pathways resulting in the formation and dissimilation of the major classes of macromolecules are discussed in Chapter 12.

Table 11.3 Trace elemental composition of yeast (μg dry wt. yeast)

	Bakers (Reed and Nagodarithana, 1991)	Brewers (Eddy, 1958)	Brewers (Eddy, 1958)	Brewers (Eddy, 1958)
Aluminium	–	3.0	2.0	1.0
Calcium	0.75	–	–	–
Chromium	2.2	37.0	104.0	34.0
Copper	8.0	–	–	–
Iron	20.0	17.0	104.0	25.0
Lead	–	2.0	14.0	100.0
Lithium	0.17	–	–	–
Magnesium	1.65	–	–	–
Manganese	8.0	4.0	5.0	11.0
Molybdenum	0.04	0.1	0.04	2.7
Nickel	3.0	3.0	4.0	3.0
Phosphorus	13.0	–	–	–
Potassium	21.0	–	–	–
Selenium	5.0	–	–	–
Silicon	30.0	–	–	–
Sodium	0.12	–	–	–
Sulphur	3.9	–	–	–
Tin	3.0	3.0	> 100	3.0
Vanadium	0.04	–	–	–
Zinc	170.0	–	–	–

11.5 Yeast morphology

Individual yeast cells are not visible to the human naked eye and they become evident only when proliferation produces a mass of many millions of cells. When this occurs, yeast cells take on the appearance of surface pellicles, sediments or hazes on or within the body of liquids. *Saccharomyces* yeast *en masse*, is off-white, grey or beige in appearance. Commonly, yeast biomass is stained by components of the growth medium adhering to the yeast cell wall. Brewing yeast strains that are non-flocculent in character form smooth creamy slurries in beer. Such yeasts are termed 'powdery'. Conversely, flocculent strains form slurries with a distinct granular appearance in which the yeast readily separates from the beer.

When a yeast cell is transferred to a laboratory nutrient medium solidified with agar or gelatin subsequent proliferation results in the formation of a roughly circular mass of cells termed a colony. The size and shape of colonies varies with the yeast species, nature of the growth medium, the solidification agent and the conditions under which the plates are incubated. Providing these parameters are defined some individual yeast strains give rise to colonies that have a characteristic morphology. This has been used as a method of yeast differentiation (Section 13.9).

The size and shape of cells and the patterns of vegetative propagation are characteristic of individual yeast species and may be used as aids to identification (Fig. 11.1). A description of cells of *S. cerevisiae* provided by Lodder (1970) is 'spheroidal, subglobose, ovoid, ellipsoidal or cylindrical to elongate, occurring singly or in pairs, occasionally in short chains or clusters'. The ratio of the long and short axes of cells of *S. cerevisiae* averages approximately 1.4:1, although some cells are longer and thinner than this. Most fall within the range of 2.5–4.5 μm and 10.5–20 μm along the short and long axes, respectively. Cell volumes range between 50 and 500 μm^3 .

Cell size is a characteristic of individual strains although there is considerable variation within strains depending on the phase of the growth cycle and cultural conditions. Thus, the mean cell size increases with increase in incubation temperature, within the normal range for any given strain. The cell wall of yeast is relatively flexible. This accommodates transient variations in cell volume in response to sudden shifts in osmotic pressure of the suspending medium. For example, when yeast slurries suspended in beer are transferred to wort there is an increase in cell size, which persists for the first few hours and precedes the onset of budding (Quain, 1988). As cells proceed through the growth cycle, there are changes in cell size and density. During the budding phase, the cell volume decreases by approximately a third. In the intervals between budding, there is an increase in cell density due to a loss of water (Baldwin and Kubitschek, 1984). Cell size of brewing yeast has been reported to decrease during the period when yeast is stored between cropping and re-pitching (Cahill *et al.*, 1996). During 14 days storage at 4 °C, the mean cell volume of an ale yeast fell from 302 to 244 μm^3 and a lager strain from 208 to 194 μm^3 , ascribed to reduction in biomass due to glycogen turnover.

The mean cell size increases with generational age. For any given strain there is a rough correlation between number of bud scars and mean cell size. Using a diploid lager yeast strain Barker and Smart (1996) reported that the mean cell volume of virgin daughter cells was approximately 150 μm^3 . Cells, which had undergone around 20 rounds of budding and were approaching the end of their life spans, had mean cell volumes of approximately 850 μm^3 . Brewing yeast cells tend to be bigger than haploid laboratory strains of *S. cerevisiae*. This is a consequence of the fact that the former tend to be polyploid/aneuploid. Galitski *et al.*, (1999) measured the mean cell volume of haploid,

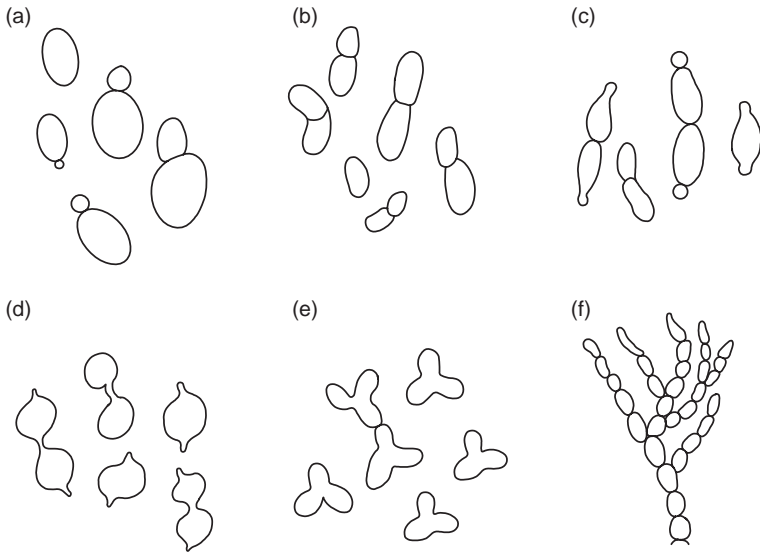

Fig. 11.1 Drawings of vegetative cells of (a) *Saccharomyces cerevisiae* (multilateral budding); (b) *Schizosaccharomyces pombe* (vegetative reproduction by binary fission); (c) *Nadsonia* sp. (apiculate (lemon) shaped cells undergoing bipolar budding); (d) *Sterigmatomyces halophilus* (conidiospores borne on short stalks); (e) *Trigonopsis variabilis* (triangular shaped cells buds borne in angles); (f) *Oosporidium margaritifera* (multilateral budding in which cells remain attached and form long chains).

diploid, triploid and tetraploid constructs of a strain of *S. cerevisiae*. These were found to be 72, 111, 152 and 289 μm^3 , respectively.

11.6 Yeast cytology

Yeast cell ultrastructure became amenable to detailed study with the advent of electron microscopy. Such techniques include scanning electron microscopy, which allows detailed examination of surface topology. A more recent development, atomic force microscopy, performs a similar function although in this case at the level of individual molecules (De Souza *et al.*, 1996). Confocal microscopy provides three-dimensional imaging of cells by measuring fluorescence light intensity produced by a laser-scanning device (Bacallao and Stelzer, 1989). Transmission electron microscopy is suitable for producing images of very thin sections of cells. The study of individual cellular organelles was largely dependent on the development of techniques that allowed the controlled disruption of yeast cells and recovery of undamaged organelles (Lloyd and Cartledge, 1991).

An idealized representation of a section through a budding yeast cell is shown in Fig. 11.2. The diagram shows all the major organelles present that may occur in the cell. Not all of these are visible at any given time. In some non-brewing yeast genera, there is an external capsule, which is attached to the outside of the wall. The cell wall, plus capsule if present, plasma membrane and the intervening periplasmic space are collectively referred to as the cell envelope. Modifications to some organelles occur as the cell progresses through the cell cycle. Some changes occur in response to growth conditions.

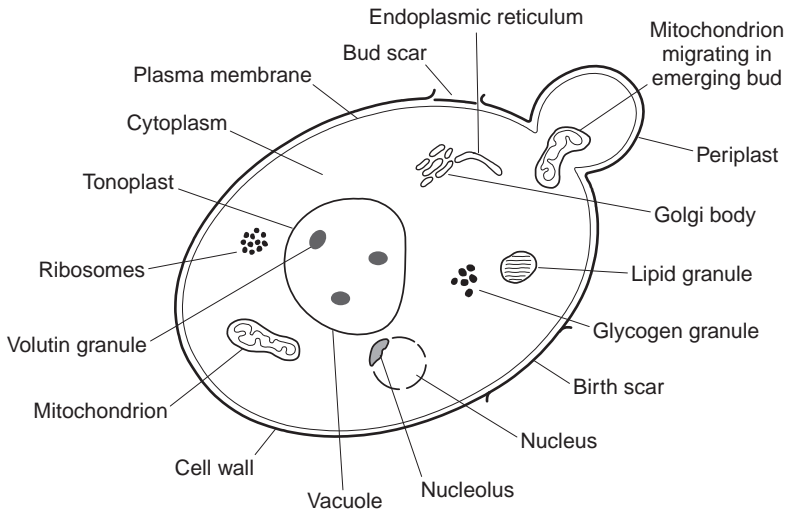

Fig. 11.2 Diagrammatic representation of a section through a typical budding yeast cell.

11.6.1 Cell wall

The wall is the outermost layer of the cell. It is of rugged construction, typically between 150 and 200 nm in thickness and accounts for approximately 20% of the total cell dry weight (Smits *et al.*, 1999). Cells that have undergone vegetative reproduction by budding bear characteristic circular bud scars. These mark the point on the wall at which the daughter cell was excised from the mother. The bud scar region is relatively rich in chitin. This can be seen following treatment with fluorescent dyes such as calcofluor. The point on the daughter cell wall, which corresponds to the bud scar on the mother cell, is termed the birth scar. Buds do not arise randomly on the cell surface but occur at specific locations. The patterns of bud scars are frequently characteristic of individual species. The process of budding is described in more detail in Section 11.7.

The cell wall is approximately 90% carbohydrate, the remainder being protein. A diagrammatic representation of a section through the cell wall is shown in Figs 11.3–4. The most abundant carbohydrates are glucans, which make up around 30–50% of the total dry weight of the wall. Glucans are arranged into long fibrillar structures, which are joined together by β -1,3 and β -1,6 linkages. Most of the remaining cell wall carbohydrate is mannoprotein (Fig. 11.5). This is comprised of an inner core region of repeating α -1,6 linked mannose (4.8) residues with short side chains attached via α -1,2 and α -1,3 linkages. The inner core region is attached to an outer chain of 100–150 mannose residues. This also consists of a backbone of α -1,6 linked mannose residue with side chains attached via α -1,2 linkages. The side chains are of manno- β -D-glucopyranoside (M^2-1M), manno- β -D-glucopyranoside (M^2-1M^2-1M), manno- β -D-glucopyranoside (M^2-1M^3-1M) and manno- β -D-glucopyranoside ($M^2-1M^2-1M^3-1M$). The precise composition of these side chains varies between yeast strains. Some of the side chains contain phosphodiester linkages and these confer an overall negative charge to the cell envelope. The side chains of the mannose molecules are the sites of the receptors, which are implicated in yeast flocculation (Section 11.6.1.1). The other end of the inner core region is attached to two N-acetyl glucosamine residues. One of these is attached to a protein molecule via the carboxylic acid moiety of an aspartic acid residue. Attached to the protein via the hydroxyl groups of serine (4.45) and threonine (4.46) are short α -1,2 and α -1,3 chains of mannose residues.

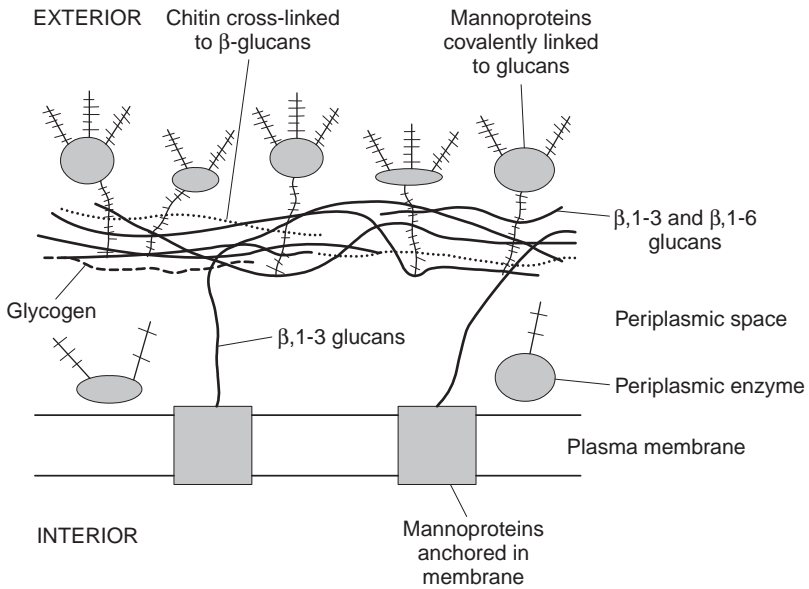

Fig. 11.3 Diagrammatic representation of a section through the yeast cell envelope.

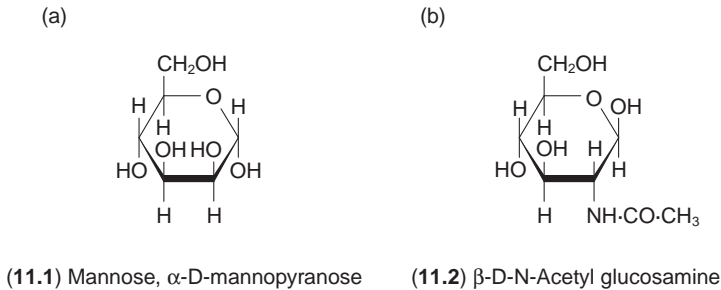

Fig. 11.4 The structures of (a) α -D-mannose and (b) β -D-N-acetyl glucosamine.

Chitin consists of a linear polymer of molecules of N-acetyl glucosamine linked by β -1,4 groups. It accounts for less than 5% of the dry weight of the wall in *S. cerevisiae*. Almost all is located within the bud scars although a small quantity is distributed throughout the rest of the wall. The fourth and also minor carbohydrate component of cell walls is glycogen. It is acid soluble and distinct from the alkali soluble pool, which functions as a reserve material. It has been demonstrated that the acid soluble fraction is structural and is linked to β -1,3 glucans via the β -1,6 glucan side-chains (Arvindekar and Narayan, 2002). Most of the protein component of the wall is associated with mannose. This fraction confers immunological properties to the cell. Some of the proteins are surface receptors and others are enzymes. The latter are those responsible for cell wall biosynthesis and the initial metabolism of some nutrients (Fleet, 1991).

The precise macromolecular structure of the cell wall remains uncertain. The glucan fibres are mainly located within the inner part of the wall. It is considered that the fraction of glucans attached by β -1,3 linkages form an interwoven network of fibrils responsible for conferring strength and flexibility to the wall. The β -1,6 linked glucans form a

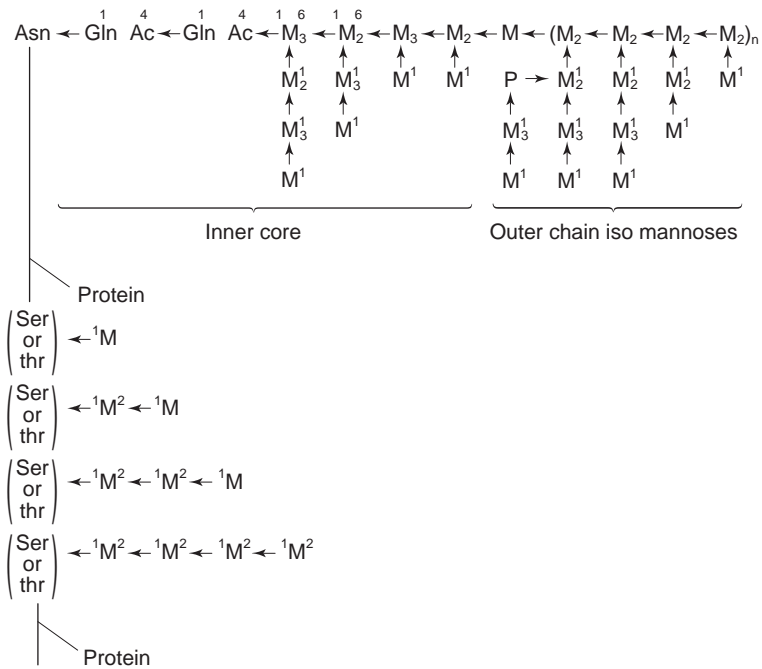

Fig. 11.5 Yeast phospho-mannoprotein. M, mannose; Gln-Ac, N-acetyl glucosamine; asn, asparagine; ser, serine; thr, threonine.

connection between this fibrillar network and the mannoprotein, glycogen and chitin components. The mannoproteins are mainly situated towards the outside of the wall where they form a cross-linked layer covalently bonded to the glucans. The extent of cross-linking between the mannoproteins appears to determine the size of molecule that can pass through the wall. A second class of mannoproteins is attached to the plasma membrane and project across the periplasmic space through the glucan layer (Fleet, 1991). These mannoproteins are implicated in flocculation and sexual agglutination. The fraction of chitin not located in bud scars is distributed throughout the body of the cell wall. Its function is unclear although it appears to have structural significance since mutants lacking it are sensitive to osmotic shock (Fleet, 1991). Chitin is the receptor for binding of killer toxin to yeast cells (Takita and Castilho-Valavacius, 1993).

The cell wall has several functions. It forms a protective layer over the comparatively fragile plasma membrane. It has a degree of flexibility, which allows rapid fluctuations in cell volume in response to changes in the osmotic potential of the external medium. Conversely, it has sufficient mechanical strength to prevent lysis when cells are subject to hypo-osmotic shock. This rigidity is responsible for conferring characteristic shapes to individual cells. The generalized rigidity and targeted weakening, together with the motive force of turgor pressure provides the means for bud development. The cell wall is a repository for several enzymes and it ultimately limits the size of molecules that may pass into and out of the periplasm. The cell wall is important in determining interactions between cells and with the external medium.

During fermentation some wort components, notably trub lipids and hop iso- α -acids, bind to yeast cell walls. Hop iso- α -acids dosage rates must be adjusted to allow for the proportion lost with the yeast crop. The impact of binding of trub components to yeast

cell walls is more difficult to assess. Potentially, the bound wort components will block receptor sites implicated in flocculation. Possibly, binding of trub components will change the overall cell surface charge and by implication affect fining behaviour. Isinglass finings are added to green beer to encourage yeast cells to aggregate together and form flocs, which promotes sedimentation. The active component in isinglass is the positively charged protein collagen, which binds electrostatically to negatively charged yeast cells. Pre-loading of yeast cells with positively charged material interferes with the action of isinglass (Leather *et al.*, 1997).

The cell wall plays a role in determining whether or not yeast rises to the surface (top yeast) or sediments (bottom yeast) during wort fermentation. Differences in the two types of yeast can be demonstrated simply by placing a suspension of yeast in water in a test tube and shaking the mixture. Top yeasts form a surface pellicle at the interface between water and air. Bottom yeasts remain distributed throughout the water. Top fermenting yeasts form loose flocs during fermentation. These trap rising carbon dioxide bubbles and the mass of gas and yeast form a type of foam akin to a head on a beer. The cell walls of top fermenters are more hydrophobic than bottom yeasts. It has been demonstrated that hydrophobicity shows a negative correlation with the content of phosphate in the outer part of the cell wall (Mestdagh *et al.*, 1990). Highly hydrophobic cells (low cell wall phosphate content) would tend to be attracted to bubbles and the surface of polar liquids such as fermenting wort.

The phosphate content of the wall is the major determinant of another measure of the cell surface, that is zeta potential (Lawrence *et al.*, 1989). This parameter is a measure of the surface charge of yeast cells. Apart from the phosphate content of the wall, it is also influenced by the pH of the surrounding medium. Zeta potential reportedly declines (becomes less negative) either during or at the end of fermentation (Iserentant, 1996). This would tend to reduce the electrostatic repulsion between individual cells and thereby favour the formation of flocs.

11.6.1.1 Flocculation

Flocculation is the reversible process by which some yeast cells adhere to each other to form aggregates. It is distinct from budding, which arises via budding and non-separation of daughter cells. Flocculation is of enormous significance to brewing. The propensity of yeast to form flocs is an integral part of the process of separating the crop from green (immature) beer. Top fermenting types form flocs that rise to the surface of the fermenting vessel. The resultant yeast head can be removed by skimming or suction. Bottom fermenting yeast form flocs which settle into the base of the fermenting vessel, a process which is encouraged by chilling the green beer. The bottom crop can be removed from the fermenter before the beer is racked. The formation of flocs is an essential precursor of crop formation. Inadequate flocculation results in poor cropping such that there may be insufficient yeast for re-pitching and green beer with unacceptably high residual yeast counts. Conversely, if flocculation occurs too soon, fermentation may arrest because insufficient cells remain suspended in the fermenting wort.

Flocculation is observed in strains from several genera. Conversely many strains, including several *Saccharomyces* brewing strains, do not flocculate to any great extent under any circumstances. Brewing strains possessing desirable flocculation characteristics will have been chosen by 'natural selection' as being the most suitable for use with particular combinations of wort and fermenting vessels. Flocculation and flocculence are distinct. The latter is an inherent property that some strains possess. The former refers to the expression of flocculence in those strains capable of so doing. By inference, flocculation is not expressed under all conditions. Commonly, flocculation occurs only

when sources of fermentable sugars are exhausted. It has been suggested (Iserentant, 1996) that under such starvation conditions the ability to form flocs may represent a stress response. Thus, flocs provide a sheltered environment where the chance of survival of the population is enhanced. Disaggregation of flocs occurs if the cells are again exposed to a source of fermentable sugar. In this case, the re-adoption of a single cell mode affords unimpeded opportunity to utilize the supply of sugar.

The precise mechanism by which flocculation occurs is controversial and there is no consensus that there is a single mechanism that applies to all yeast strains. The onset of flocculation is observed in laboratory cultures that have just entered the stationary phase of growth. Similarly, in brewing, flocculation occurs towards the end of primary fermentation. Nevertheless, exponentially growing yeast cells can be made to flocculate providing they are removed from the growth medium and washed and suspended in water, supplemented with Ca^{2+} ions. Cells must come into contact with each other for flocculation to occur, hence the surprising observation that flocculation and the vigour of mechanical agitation are positively correlated. Thus, in well-stirred systems there is a high probability that cells will contact each other and once formed, flocs are relatively stable structures.

Flocculation occurs because of interactions between surface proteins on one cell and carbohydrate receptors on another cell (Miki *et al.*, 1982). It has been demonstrated that flocculation can be inhibited by pre-treatment of cells with agents that block these interactions. This has allowed classification of yeasts based on the nature of agents that inhibit flocculation. The evidence suggests that the protein component is a lectin since an excess of related lectins, such as Concanavilin A, abolishes flocculation. Similarly, simple sugars, which also bind to lectin-like proteins, also prevent or reverse flocculation. Three phenotypes have been recognized based on which sugars inhibit flocculation (Stratford and Assinder, 1991; Dengis *et al.*, 1995). Flo1 types do not flocculate in the presence of mannose, whereas mannose, sucrose, glucose and maltose abolish flocculation of NewFlo types. The MI phenotype flocculates in the presence of both mannose and sucrose but not in the absence of ethanol (Table 11.4). The MI phenotype is totally distinct from the other two groupings. In these cells flocculation occurs via direct (non-lectin like) protein – protein interaction. These strains are top-fermenters and have highly hydrophobic cell envelopes. Possibly the latter promotes both the formation of flocs and encourages formation of a yeast head.

Flo1 and NewFlo types all use interactions between lectin-like proteins and cell surface mannans. The groups differ in the nature of the lectins. These can be differentiated based on differences in patterns of proteolytic digestion and response to pH. Synthesis of particular lectins is dependent on the possession of the relevant genes. Genetic differences underpin the flocculation phenotypic classification. Both NewFlo and Flo1 phenotypes use common carbohydrate receptors. Based on studies with mutants Stratford (1992) has demonstrated that the receptors are the side chains of the outer mannose chain of cell wall mannoproteins (Fig. 11.5). NewFlo and Flo1 types have an obligate requirement for Ca^{2+} ions for flocculation to occur. Absence of this ion, or the presence of chelating agents prevent flocculation. The role of calcium is probably that of ensuring that the lectin-like protein is in the correct configuration for binding to the mannose receptors.

The stability of flocs is proportional to the number of interactions between individual cells and the number of potential binding sites, both protein and mannose per unit area of cell wall will be influential. In addition, spatial considerations must play a role in allowing cells to pack together and make the intimate contacts necessary for interactions

Table 11.4 Classification of yeast flocculence phenotypes (Straford, 1994)

Class	Phenotype	Inhibitors	Requirement for Ca ²⁺	Comments
Flo 1	Heavily flocculent throughout fermentation	Mannose	Yes	Mannose absent from wort
New Flo	Most brewing strains	Mannose, sucrose glucose, maltose	Yes	Flocculation at end of primary fermentation
MI	Heavily flocculent and top-fermenting	Flocculation not inhibited by sugars	No	Cells require presence of ethanol for flocculation to occur

to occur. This suggests that electrostatic and hydrophobic effects might also be important. In brewing, the onset of flocculation observed at the end of primary fermentation is explained because the inhibitory effect of sugars is alleviated by their exhaustion from the wort. Similarly, cells disaggregate at the start of fermentation when yeast suspended in beer is pitched into fresh sugar-containing wort.

The genetics of flocculation is complex and still not fully characterized (for a review see Jin and Speers, 1998). A number of genes have been identified, termed FLO, which are reportedly implicated in flocculation. It is assumed that some of these encode for the lectin-like proteins. The possession of genes producing different lectin-like proteins presumably underpins the NewFlo and Flo1 phenotypes. Strains that do not possess any of these genes are not flocculent under any circumstances. Thus, there is evidence that a gene, termed FLO1 encodes for a cell surface protein, which has been implicated in flocculation. Transfer of this gene from a flocculent yeast strain to a non-flocculent type is accompanied by the acquisition of a flocculent phenotype (Teunissen and Steensma, 1995).

11.6.2 The periplasm

The periplasm is the space between the cell wall and the plasma membrane. Although not an organelle as such it is a void that must be traversed by all in-coming nutrients and outgoing metabolic by-products. It is the location of several enzymes including invertase, acid phosphatase, melibiase and various binding proteins. These are produced extracellularly, that is exterior to the plasma membrane, but they are retained by virtue of being too large to pass through the cell wall. The periplasm is not a continuous void since some components of the cell wall are anchored in the plasma membrane (Fig. 11.3). Possibly (Arnold, 1991) the retention of enzymes that are capable of hydrolysing otherwise non-assimilable nutrients affords a competitive advantage compared to organisms that excrete free extracellular enzymes. The protein content of the periplasm may be sufficiently high to make the fluid gel-like. Thus, the periplasm may also function as a protective layer between the cell wall and plasma membrane.

11.6.3 The plasma membrane

Plasma membranes enclose the cytoplasm and form the inner barrier between the cell wall and periplasm. The yeast plasma membrane resembles that of other eukaryotic cells. It consists of roughly equal quantities of lipid and protein. The proteins are diverse and mainly functional as opposed to structural. They include the enzymes responsible for cell

wall synthesis, those catalysing the uptake of nutrients, the ATPase responsible for maintaining the proton motive force and possibly receptors of cellular signalling systems. Membrane lipids are mainly the phospholipids, phosphatidylinositol (4.122), phosphatidylserine (4.121), phosphatidylcholine (4.118) and phosphatidylethanolamine (4.120). In addition, smaller quantities of sterols are present, the most abundant being ergosterol.

The precise architecture of the plasma membrane remains uncertain. The fluid mosaic model (Singer and Nicholson, 1972) describes membranes as being bilayers of phospholipids in which the hydrophobic groups are turned inwards to face each other. The hydrophilic moieties are turned outwards and are in contact with the aqueous environment in the periplasm and cytoplasm, respectively. Proteins and sterols are located within the phospholipid bilayer. Sterols have polar hydroxy groups and a hydrophobic skeleton. This allows them to orientate themselves in a perpendicular plane between the hydrophobic chains of the phospholipids.

The plasma membrane forms the barrier between the cytoplasm and the external environment. It prevents free diffusion of solutes and provides a support in which specific carrier proteins catalyse the selective uptake and excretion of metabolites. It provides a framework whose structure allows the generation of proton and ion gradients necessary for the generation of energy that drives many uptake reactions. An essential facet of cellular function is the ability to detect and respond to external stimuli. Receptors of cellular signalling systems are conveniently situated within the plasma membrane. The membrane provides a site where enzymes involved in various cellular synthetic pathways can be located in a manner that favours spatial arrangement and function.

11.6.4 The cytoplasm

The cytoplasm is that portion of the cell enclosed by the plasmalemma and excluding other membrane bound organelles. It is an aqueous colloidal liquid containing a multitude of metabolites. The cytoplasm of yeast is particularly rich in RNA. It is acidic, typically about pH 5.2, although localized metabolic activity may produce micro-environments of greater or lesser acidity. The enzymes of several major metabolic pathways are located within the cytoplasm, for example, glycolysis and fatty acid synthesis. Enzymes such as those of glycolysis are described as being 'soluble' because in cell-free extracts the enzymes can be found in the supernatant when all membranous material has been removed by centrifugation. In fact, many of these enzymes are not randomly dispersed throughout the cytoplasm. Instead, they are arranged in spatial configurations that aid ordered activity, possibly in loose associations with intracellular membranes.

The cytoplasm contains a number of inclusions. Glycogen accumulates under appropriate conditions and appears in the cytoplasm as small granules that can be stained purple with iodine. Lipid particles become visible in the cytoplasm during aerobic growth when there is a plentiful supply of carbon. The particles apparently contain a hydrophobic core of triacylglycerol and steryl esters surrounded by a membrane consisting of phospholipid and protein (Leber *et al.*, 1994). Probably lipid granules are temporary storage structures from which sterols may be transported to growing membranes and triacylglycerols withdrawn in times of need.

Ribosomes are cytoplasmic organelles that contain high concentrations of RNA and some protein. Their role is to assemble proteins from 'activated' amino acids sequenced in response to the code present in molecules of messenger RNA. Ribosomes are found throughout the cytoplasm either borne freely or often associated with the outer membranes of mitochondria, the endoplasmic reticulum and the outer nuclear envelope.

Commonly, several ribosomes are associated together joined by a strand of messenger RNA in structures termed polysomes.

11.6.5 Vacuoles and intracellular membrane systems

Yeasts, like other eukaryotes, contain extensive and dynamic internal membranous systems. These provide a method for partitioning metabolic pathways and pools of metabolites. They are also involved in the transport of metabolites both within the cell and to and from the plasma membrane. The most visible intracellular membranous system is the vacuolar system. Vacuoles are bodies bound by a membrane, the tonoplast. Their size and number fluctuates with physiological condition and stage in the cell cycle. When cells are growing in a balanced medium, as is the case during active primary fermentation, they may not be visible. Extensive vacuolation is associated with stress in yeast, especially starvation. Commonly large vacuoles become apparent in late fermentation or in stored pitching yeast.

Vacuoles serve as temporary metabolite stores and provide the cell with a mechanism for controlling the concentration of metabolites in other cellular compartments. They are the site for the catabolism of macromolecules such as proteins. Vacuoles contain several proteinases, hence high concentrations of amino acids, especially basic types are also present. Thus, vacuoles function as a repository for nitrogen-containing metabolites. Their role as sites for proteolysis is consistent with the observation that they are most visible during starvation. The tonoplast, or vacuolar membrane, contains several amino acid transporters and is the site of a membrane-bound proton translocating ATP-ase. The latter is reportedly responsible for vacuolar acidification, which is an essential part of protein sorting (Klionsky *et al.*, 1992).

Vacuoles store quantities of inorganic phosphate, in the form of linear polymers of polyphosphate linked by high-energy phospho-anhydride bonds. Reportedly, polyphosphate is associated with S-adenosyl-L-methionine in vacuolar structures, termed volutin granules. These may be involved in the sequestration of basic amino acids (Schwenke, 1991).

The Golgi body comprises a dynamic series of stacked membranes and vesicles. It is part of the yeast secretory system and forms a link between the endoplasmic reticulum, the tonoplast and the plasma membrane. The endoplasmic reticulum consists of a branching network of membrane bound tubules. The Golgi body and the lumen of the endoplasmic reticulum are sites where proteins are sorted, modified and possibly assembled into complexes whilst being directed towards a chosen destination. Proteins, which are synthesized by ribosomes, may be transported across the membrane and into the endoplasmic reticulum. From here, they are directed towards the Golgi body via vesicles. In the Golgi body proteins are sorted and directed towards the sites where they are required. This may be within other intracellular organelles although most are sent to growing membranes. Many proteins, as evidenced by the numbers of visible vesicles, are sent to the area of membrane around the growing bud tip. Incorrectly folded proteins can be encapsulated in vesicles and returned to the endoplasmic reticulum. There they are repaired or degraded.

Some proteins, encapsulated in vesicles, are transported across the plasma membrane and secreted into the periplasm in a process termed exocytosis. A reverse process, termed endocytosis in which proteins are imported into the cell also occurs. The cytoplasm also contains a system of microtubules and microfilaments. These constitute the cytoskeleton and are involved in the spatial organization of the cell especially during meiosis and mitosis.

Two cytoplasmic membrane-bound bodies, peroxisomes and glyoxysomes are associated with particular physiological states. Peroxisomes contain catalase and oxidases required for the metabolism of specific carbon sources such as hydrocarbons and methanol. In glucose-grown cells of many yeast strains, including *Saccharomyces* spp, peroxisomes are barely evident. Transfer to a medium containing a carbon source such as methanol results in the rapid biogenesis of peroxisomes in those strains capable of utilizing such substrates. Glyoxysomes are similar to peroxisomes but are rich in the enzymes of the glyoxylate cycle. Neither peroxisomes nor glyoxysomes are of relevance to brewing yeast under the conditions experienced during fermentation.

11.6.6 Mitochondria

Mitochondria are cytoplasmic organelles whose appearance and structure is much influenced by physiological state (Visser *et al.*, 1995). Their principal role is energy generation via oxidative phosphorylation. They are most evident in cells growing aerobically under derepressed conditions (see Chapter 12). During oxidative derepressed growth, the mitochondrial volume (chondriome) accounts for some 12% of the total cell volume in *S. cerevisiae*. During anaerobic growth or under repressing conditions the chondriome is much reduced. Yeasts typically have a single or small number of large multi-branched mitochondria. Mitochondria have two membranes separated by an intermembrane space. The internal membrane has projections (cristae) that project into the internal matrix. Mitochondria contain a self-replicating genome, which codes for around 5% of all mitochondrial proteins. The remaining mitochondrial proteins are encoded by the nuclear genome and therefore biogenesis of these organelles requires co-ordinated expression of both sets of genes.

Mitochondria are the site of the electron transport chain and oxidative phosphorylation resulting in the generation of ATP. In addition, there are enzyme systems for transporting many metabolites both into and out of the mitochondria, not least ATP. Several other enzyme systems unrelated to energy transduction are also located within this organelle including those of the oxidative tricarboxylic acid cycle, pyruvate dehydrogenase complex, several amino acid biosynthetic enzymes, the Mn-linked superoxide dismutase and possibly some of the sterol biosynthetic pathway. Under the repressing and anaerobic conditions of brewery fermentations, mitochondria do not contain the enzymes systems associated with oxidative metabolism. The genes coding for the proteins of the electron transport chain and several enzymes of the tricarboxylic acid are not expressed. The organelles remain in a partially undifferentiated state, termed promitochondria. These are small, difficult to visualize and internally few or no cristae are present. The chondriome is reduced to approximately 3–4% of the total cell volume (Stevens, 1977).

Mitochondria do not have an energy-generating role during fermentation. Nevertheless, their presence is essential for normal fermentation behaviour because of the other metabolic functions they perform. O'Connor-Cox *et al.* (1996) have reviewed the functions of mitochondria, considered essential for normal fermentation performance. These include expression of flocculation, amino acid and diacetyl metabolism, sterol biosynthesis and physiological adaptation to stress.

11.6.7 The nucleus

The nucleus contains the greater part of the genetic material of the cell. It is roughly spherical, 1–2 micron (μm) in diameter and enclosed by a double membrane. The

membrane is not continuous but contains several pores. The organelle is visible, with some difficulty, under the light microscope. In stationary phase cells it is often closely associated with vacuoles. The internal structure and appearance of the nucleus changes throughout the cell cycle. During interphase, a crescent shaped nucleolus is visible, associated with the nuclear membrane. The nucleolus is the site of rRNA transcription, some of the initial stages of mRNA processing and the assembly of ribosomal sub-units. The nuclear DNA of a haploid cell is distributed between 16 linear chromosomes. The smallest chromosome (I) is 230 kb in length, the largest (IV) 1532 kb. The nuclei of most strains contain up to 100 copies of a 2 μm plasmid. This is a circular molecule of DNA and accounts for approximately 1% of the total nuclear DNA.

Chromosomal DNA and proteins, both histones and non-histones are arranged together to form a complex termed chromatin, so named because of its property of staining with basic dyes. In chromatin, the double helical DNA molecule is bound to a core of histone. Individual building blocks of DNA and histone are termed nucleosomes. Nucleosome units are coiled and condensed in hierarchical levels to form a supercoiled macromolecule. The protein component allows selective transcription of the genes on the chromosome. In comparison with higher eukaryotes, the chromatin molecules are loosely wound. This supports the view that the small genome is highly transcribed (Williamson, 1991).

The terminal regions of chromosomes are termed telomeres. These are involved in protecting the ends of chromosomes from degradation, maintaining the structural integrity of chromosomes, assisting in replication of DNA at the terminal region and possibly in the attachment of chromosomes to the nuclear membrane during meiosis. Chromosomes also contain regions termed centromeres. These structures consist of DNA and protein and are the part of the chromosome that is attached to the spindle body during mitotic division. Now the DNA component alone is called the centromere. The centromere is required to assemble a large protein complex, termed the kinetochore. This structure mediates the attachment of chromosomes to spindle microtubules during mitosis and ensures that each daughter cell receives a complete set of chromosomes. Errors in chromosome segregation lead to alterations in chromosome copy number in daughter cells. This condition is termed aneuploidy. Interestingly, this is the common condition in the case of the genome of brewing yeast strains (Section 11.8.2).

The spindle body acts as a scaffold, which mediates nuclear division and migration and segregation of daughter chromosomes during mitosis. It is a dynamic structure that undergoes considerable changes during cellular budding. A complete spindle body consists of two spindle pole bodies and a number of microtubules (Fig. 11.6) Spindle pole bodies are electron dense plugs, approximately 0.15 μm in diameter, which are located within the nuclear membrane. Short cytoplasmic (astral) microtubules project from a dense amorphous layer situated just above the spindle pole body. Two, or three, further types of microtubule are attached to a second amorphous dense area situated between the spindle pole body and the inner surface of the nucleus. Short discontinuous microtubules project a short distance into the nucleus. These are of two types. Firstly those that interact with the arms of chromosomes and secondly, those which interact with the kinetochore. Continuous microtubules form a direct link across the diameter of the nucleus between adjacent spindle pole bodies. All microtubules are approximately 20 nm in diameter. They all consist of repeating units of two proteins termed α - and β -tubulin.

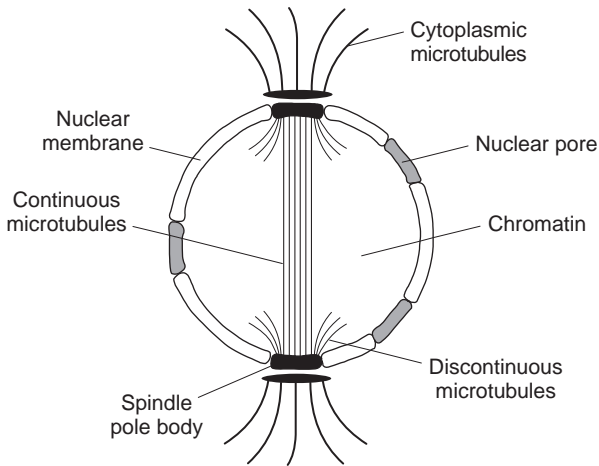

Fig. 11.6 Diagrammatic representation of a section through the nucleus of a yeast cell in early G2 phase.

11.7 Yeast cell cycle

Proliferation of unicellular organisms involves coordination of the biochemical processes that together underpin growth of individual cells and those specific events that culminate in cellular multiplication. The combination of events that occur during the intervals between the separation of successive daughter cells is termed the cell cycle. It requires coordination of continuous events such as cellular growth with the discontinuous processes of DNA replication, mitosis and daughter cell excision. These processes in yeast have been subjected to intensive scrutiny.

Progression through the cell cycle can be considered from three standpoints. Firstly, the morphological changes that occur as a mother cell gives birth to a daughter. Secondly, the biochemical events that underpin the process of cellular proliferation. Thirdly, the molecular mechanisms that regulate the coordinated processes of cellular growth and multiplication. For convenience, the cell cycle is divided into a number of phases (Fig. 11.7). These are termed G1, which is the pre-synthetic gap phase; S, the synthetic phase during which DNA is replicated; G2, the post-synthetic gap phase, M, the mitotic phase and cytokinesis, the phase during which the daughter cell separates from the mother. During mitosis, the nucleus divides and duplicate pairs of chromosomes (chromatids) are sorted and segregated between the mother and daughter cell. In 'classical' descriptions of mitosis, the process is delineated as a series of distinct and named morphological states. In *S. cerevisiae* these steps are not clearly distinct.

The gross morphology of mitotic cellular multiplication depends on the yeast type. In fission yeast, such as *Schizosaccharomyces pombe*, the mother cell divides to form two equal sized progeny. In the case of budding yeast such as *S. cerevisiae*, division is asymmetrical, the daughter cell being smaller than the mother. In some budding yeasts, the point where the bud forms is limited to specific points on the cell wall such as the poles. In others, including *S. cerevisiae*, buds may arise from any point on the cell wall. Nevertheless, buds do not arise more than once at the same location. The determination of the precise site of bud initiation is a regulated process. Bud formation and separation is accompanied by nuclear division and segregation. This is a directional process and thus, the cell must be polarized to ensure correct orientation of the dividing nucleus and the

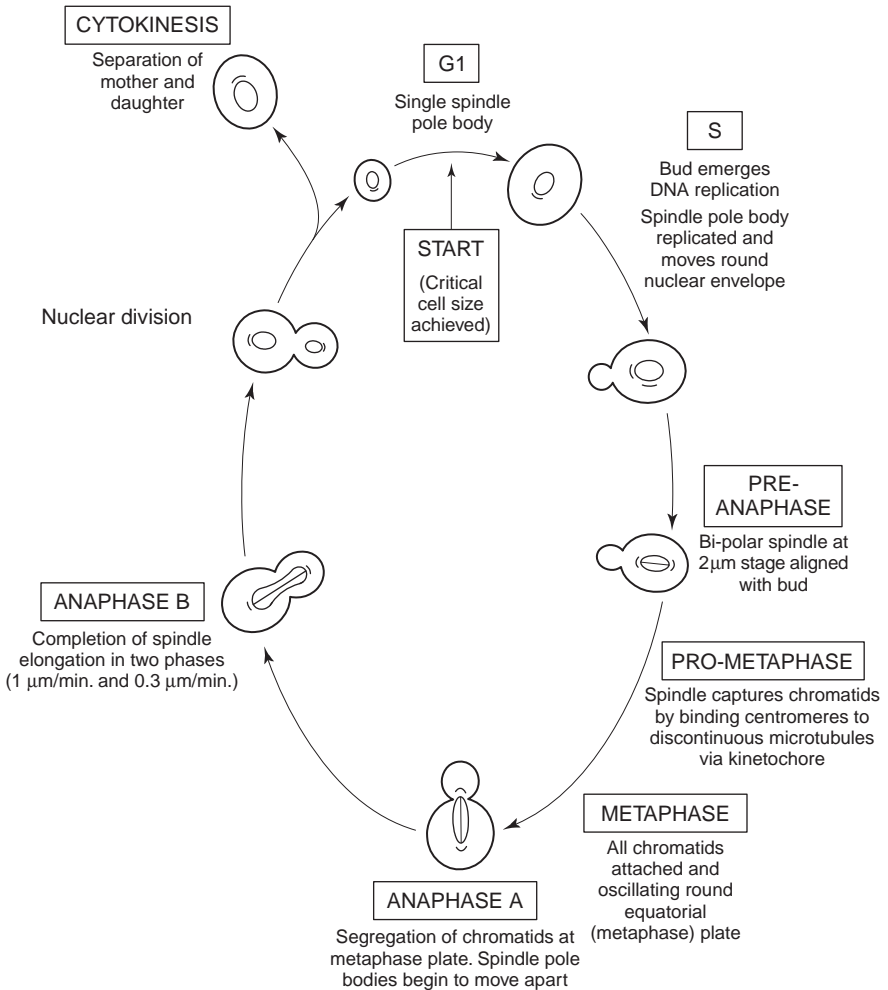

Fig. 11.7 Phases in the cell cycle of *S. cerevisiae* (including brewing yeast strains).

developing bud. This is accomplished by the intermediary of the actin cytoskeleton and the spindle body.

Bud emergence occurs in response to localized degradation of the cell wall. The site of bud initiation is marked by the development of a ring structure, containing filaments termed septins (Harold, 1995). This process is accompanied by the accumulation of cytoplasmic vesicles in the area directly below the developing bud. These contain enzymes and precursors of cell wall synthesis. The vesicles are transported to the site using the actin microtubules of the cytoskeleton. The motive force for vesicle transport is provided by a multi-subunit protein termed dynein. Some of the sub-units of dynein provide an anchor attaching the vesicle 'cargo' to the microtubule. Other subunits provide the motor force to move the vesicle from the positive to the negative end of the microtubule. The process is energized by the dissipation of ATP. The vesicles convey their contents to the site of bud growth by fusing with the plasma membrane in a process of exocytosis. The partial degradation of the wall allows cell turgor pressure to push out the developing bud.

Growth is restricted to the bud and there is no increase in the size of the mother cell during budding. Cell wall synthesis occurs outside the plasma membrane of the growing bud. Initially, cell wall growth is restricted to the tip of the developing bud. Gradually cell wall synthesis spreads to the whole surface of the growing bud. At the end of mitosis, when the daughter nucleus and organelles such as mitochondria have divided and have migrated to the daughter cell, a septum develops across the plane of the chitin ring. This process (cytokinesis) is completed when the daughter cell becomes detached from the mother. The septum on the mother cell is composed of chitin and constitutes the bud scar. The corresponding point on the cell wall of the daughter cell is deficient in chitin and persists as the birth scar.

Whilst bud emergence, growth and separation is occurring the nucleus and the enclosed chromosomes are duplicated and distributed between mother and daughter. In yeast, unlike mammalian cells, the nuclear membrane remains intact during the entire process. The morphological changes that occur during replication of the nucleus and their relation to bud formation and excision are illustrated in Fig. 11.7. A brief description of the key events and associated nomenclature is also provided. The morphological changes associated with the cell cycle of *S. cerevisiae* have been visualized using time-lapse high-resolution digital enhanced differential interference contrast and multimode fluorescence microscopy (Shaw *et al.*, 1998). These techniques provide direct visualization of the nucleus, the spindle and microtubules. Time lapse video footage of cells of *S. cerevisiae* progressing through the cell cycle may be found at <http://www.molbiolcell.org>. This elegant work shows how the discontinuous nuclear microtubules capture the duplicated chromosomes and segregate them at poles of the spindle body. The extension of the spindle body via elongation of the continuous microtubules is visualized. The manner in which cytoplasmic microtubules provide the motive power and orientation for movement of the dividing nucleus into the growing bud is demonstrated.

Under the conditions used by these authors (Shaw *et al.*, 1998) the average cell cycle time was 125 \pm 9 minutes. Of this, G1 and S together required 54 minutes to complete. Development of the short bipolar spindle (preanaphase) took a further 16 minutes. Capture and sorting of the daughter chromatids and elongation of the spindle to its fullest extent (anaphase A, B) required a further 30 minutes. The final division of the nucleus, migration of daughter nucleus into the bud and cytokinesis took 25 minutes. Molecular control of the cell cycle is predictably complex. Before the cell progresses into the S phase of DNA replication, it must achieve a critical size. The cell has mechanisms for sensing that an adequate supply of nutrients is available before it commits itself to replication. When these prerequisites are satisfied the cell cycle progresses through a critical checkpoint termed START. In *S. cerevisiae* this is marked by the onset of bud emergence and DNA replication. If the cell is starved of an essential nutrient, it enters a resting state termed G₀. The requirement to achieve a critical size explains why the average duration of the cell cycle is longer for daughter cells than their mothers. Thus, the former are smaller at birth and therefore require a longer G₁ phase to achieve the critical size. A further checkpoint exists at the boundary between S and G₂. At this point, there is a further critical cell size constraint, which must be satisfied before progression into mitosis occurs. In the case of *S. cerevisiae*, cells are usually sufficiently large at start to ensure that this second checkpoint is hidden.

It can be shown to exist in the case of the fission yeast, *Schizosaccharomyces pombe*. This was demonstrated using the so-called wee mutants (Nurse, 1975). These cells have a gene, termed Wee 1, that is defective when the yeast is cultivated at high (restrictive) temperature. At the restrictive temperature, the cells undergo fission at a much smaller

size than the wild type. Thus, the normal product of the Wee 1 gene restricts entry into mitosis. The function of this second checkpoint is to allow the cell to ensure that chromosome duplication and segregation has proceeded without error. If necessary, it provides an opportunity for corrective action. This is vital since errors at this stage could have fatal consequences. Progression through the cell cycle requires activation and inactivation of enzyme systems via the intermediary of protein kinases and phosphatases. These regulatory cascade reactions are of the type described in Sections 12.2 and 12.5.8. Passage through the critical control points of the cell cycle is regulated by the controlled expression of genes that encode for catalytic proteins termed cyclins. At least 22 cyclins have been isolated. Cyclins interact with protein kinase cyclin-dependent kinases (CDKs).

Several versions of these enzymes have been isolated from various cell types. In the case of *S. cerevisiae*, activation and deactivation of *cdc28* (gene *CDC28*) regulates passage through the critical checkpoints of the cell cycle. Other cyclin-dependent kinases are also involved (Stark, 1999). The precise sequence of events is highly complex and not fully characterized. Nevertheless, the general principles are that there is a sensing system by which the cell monitors that the conditions are favourable for the cell cycle to progress. These include parameters such as nutrient availability, achievement of the critical cell size and confirmation that chromosome replication and segregation has been achieved. If the checks are satisfied, appropriate cyclins are synthesized and the cyclin-dependent kinase (*cdc28*) is activated. At START, for example, phosphorylation by the activated *cdc28* kinase (S phase promoting factor) stimulates passage into the S phase by activation of transcription. Mitosis promoting factor (*cdc28* activated by B cyclins) controls passage from G2 to M.

Individual cyclins are synthesized and degraded at various points in the cell cycle. Thus, G1 cyclins are associated with the passage from G1 to S. G2 cyclins (cyclin B) guide the cell through the transitions from S to G2 and G2 into mitosis. Successive families of cyclins are responsible not only for promoting entry into the next stage of the cell cycle but also for degrading the cyclins responsible for driving the previous stage. Degradation is accomplished using the poly-ubiquitination system associated with the yeast proteasome (Section 12.8).

11.7.1 Yeast sexual cycle

Many yeast genera are capable of sexual reproduction. *S. cerevisiae* is a perfect member of the *Ascomycetae* and is included in this group. Wild type strains of *S. cerevisiae* are usually diploid. Under appropriate conditions, these yeasts can be induced to undergo meiotic division and produce ascospores that are borne in a fruiting body, an ascus. Industrial strains of *S. cerevisiae*, including brewing strains, are typically aneuploid/polyploid and do not normally have a sexual cycle. From this standpoint, the sexual stage of *Saccharomyces* yeasts is not relevant to brewing. Nevertheless, the sexual cycle of yeast has been used widely, as a method for exploring the genome. For this reason, a brief description of the important features is included here. The key features of the yeast sexual cycle are shown in Fig. 11.8.

Haploid strains capable of sexual conjugation are of either of two mating types, termed MAT α and MAT a . Mating occurs in response to exposure of cells of opposite mating type to pheromones, termed a and α factors, respectively. The pheromones are short peptides and they bind to specific receptor sites on the surface of cells of opposite mating type. Binding of the appropriate pheromone causes cells to arrest in the G1 phase of the

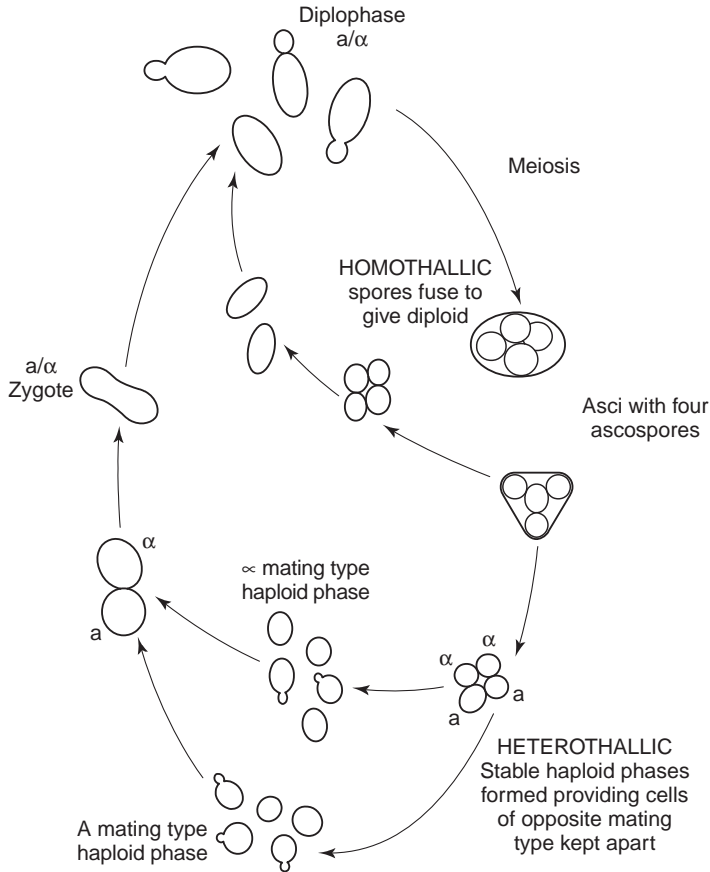

Fig. 11.8 Sexual life cycle of *S. cerevisiae*. Note that brewing strains of *S. cerevisiae* do not show a sexual cycle.

cell cycle at START and thereby achieve cell cycle synchrony. Cells develop projections known as schmoos. At conjugation, the schmoos on adjacent cells become aligned, grow towards each other and eventually fusion occurs. This is mediated by expression of genes that encode for a specific group of surface agglutinins. Sexual conjugation is therefore a specific type of flocculation. During the fusion process, the plasma membranes of each cell become contiguous so the cytoplasm is shared. Nuclear fusion, or karyogamy to give a diploid cell follows cellular fusion. In a complete growth medium such diploid cells proliferate by budding and mitosis. This stage is known as diplophase. Under conditions of nutrient starvation or in the presence of a non-fermentable carbon source such as acetate or ethanol, but no nitrogen source, meiosis occurs and four haploid spores are formed. Spores can be induced to germinate by transfer to a rich growth medium.

Two types of cell phenotype are possible depending on the possession or absence of a dominant allele termed HO. Heterothallic strains are HO⁻ and, providing the germinating ascospores are not brought into contact with a cell of opposite mating type, they will divide mitotically and produce stable haploid clones. Normally, ascospores are not liberated from the asci of *S. cerevisiae*, instead they fuse to produce diploid cells.

Homothallic strains carry the dominant allele HO. Cells growing from spores, which bear the HO gene, are able to change mating type (Herskowitz *et al.*, 1992). In budding

cells, the switch in mating type occurs only in mothers and not daughters. Once the latter have become mothers, they also acquire the ability. The switch occurs with an efficiency of approximately 60%. The result is that mating between siblings takes place and therefore, the haploid phase in homothallic strains is transient. Mating type is determined by expression of genes at the MAT locus on chromosome III. In addition, chromosome III has two 'silent' loci, or cassettes, which are located to the right and left of the centromere. These carry mating information for both MAT α (HMR, right hand of centromere) and MAT α (HML, left hand of centromere). As the terminology suggests, genes at the silent loci are not normally expressed. However, in some cases the genes at the MAT locus are exchanged with those from the silent HML or HMR loci. These silent genes may then be expressed. Depending on the original MAT locus (either MAT α or MAT α) and the substitute, mating type can be changed. In this set of circumstances the cells of opposite mating type will rapidly fuse and regenerate diploid cells.

The mating process is induced by a signal transduction pathway involving a protein kinase cascade termed MAPK (Stark, 1999). The mating pheromones bind to cell surface receptors and in so doing activate a tetrameric protein (G protein) whose sub-units dissociate in response to exchange of GDP for GTP. Sub-units of G protein in turn activate the formation of a second multi-subunit complex, which triggers the MAP protein kinase cascade. In turn this interacts with cyclins with a resultant arrest in the cell cycle at START. Other MAP kinase target sites mediate the reactions leading to shmoo formation and fusion.

In the process of meiosis, also known as reductive division, the diploid nucleus divides twice to form four haploid nuclei. In the initial fusion, two haploid nuclei fuse to form a single diploid zygote containing two sets of chromosomes. In sporulation medium, the two sets of chromosomes come together as homologous pairs (the two corresponding chromosomes from the original haploid parents). The DNA is then replicated, during which there is the opportunity for crossing over of genes between pairs of chromosomes. In this way genetic material can be shared to produce daughter cells with characteristics inherited from either parent. A process of separation then follows involving homologous pairs of chromosomes and then individual replicas.

Eventually four sets of chromosomes are formed each enclosed in a nucleus. The process of sporulation begins when spore coat materials are synthesized and deposited around the nucleus. The cell enclosing the spores develops into a spore-bearing body, the ascus. Spore formation is accompanied by the accumulation of the carbohydrate, trehalose (Dickinson, 1988). This material makes cells resistant to stresses such as desiccation by virtue of its ability to stabilize membranes (Section 12.5.7).

11.8 Yeast genetics

Genetics is the study of the relationships between the structure of the genotype and phenotypic expression. Genetic analyses provide a means of exploring the evolutionary and taxonomic relationships between individual strains. An understanding of the make-up of the genotype is a prerequisite for phenotypic modification. Thus, with knowledge of the nature of the genotype opportunities may present themselves by which undesirable characteristics can be deleted and desirable characteristics acquired. The comparatively rapid cell cycle of yeast, its ease of cultivation and relatively compact genome has made these organisms a common choice for the study of eukaryotic genetics, consequently, the

scientific literature is enormous. Nevertheless, the majority of these studies employ haploid laboratory strains of *S. cerevisiae*. As discussed below, industrial strains of *S. cerevisiae* have a more complex genetic make-up. A glossary of some terms used in genetics is given in Table 11.7 on pages 397–398.

11.8.1 Methods of genetic analysis

Genetic analyses are commonly performed using mutants. Exposure of cells to ionizing radiation or certain chemical compounds (mutagens) induces damage to the genome. Providing the treatment is not lethal, it is possible to obtain mutants. In other words, cells with an altered genotype with one or more defective genes. Selective media or selective cultural conditions can be used to identify and isolate mutants that are defective in the area of interest.

The traditional method for determining the location and number of genes within the genome is by mating and meiotic recombination. Yeast is particularly suitable for this approach since the four ascospores are the result of a single meiotic event. Tetrad analysis allows mapping of genes relative to their centromeres and the drawing up of linkage maps. The latter indicate the relative distances between genes located on the same chromosome. Tetrad analysis is laborious. It involves mating of selected haploid strains to produce a hybrid diploid. After the induction of meiosis by transfer to sporulation medium, individual haploid ascospores are isolated by micromanipulation following enzymic digestion of the ascus wall. After induction of germination, the phenotype of the resultant haploid yeast lines can be assessed. Many aspects of the phenotypes of isolates can be assessed using the technique of replica plating. Here isolates are plated out onto a complete growth medium and incubated to allow the formation of colonies. An imprint of the colonies is made by pressing a piece of sterile velvet onto the plate. This is then used to inoculate plates of media that are selective for chosen phenotypic attributes. Comparison of patterns of growth on master and replica plates allows the assessment of phenotype.

Tetrad analysis has allowed more than 90% of the genetic map of *S. cerevisiae* to be established (Cox, 1995). Although more modern techniques have superseded tetrad analysis as the method of choice for gene mapping it is still used to determine that a mutation has resulted from alteration of a single locus. Analysis of tetrads relies on the ratios of individual phenotypes to determine the relationships of the genes under investigation. Thus, a hybrid that is heterozygous for two markers, AB and ab has the potential to produce three classes of tetrad. These are: AB, AB, ab, ab (PD or parental ditypes); aB, aB, Ab, Ab (DPD or non-parental ditypes) and AB, Ab, ab, aB (T or tetratype). If the genes are unlinked, a random assortment will yield a ratio of 1 : 1 : 4 for PD, NPD and T, respectively. In the case of linked genes, there is an excess of PD to NPD tetrads. Where two genes are on different chromosomes and are linked to their respective centromeres the proportion of T type tetrads is reduced.

The distance between individual genes on chromosomes influences the chances of crossovers during meiosis. Therefore, the frequency of occurrence of the different classes of tetrads can be used to determine the distance between genes. The distance between genes is measured in centiMorgans (cM). A centiMorgan is the unit on a genetic map equal to the distance along a chromosome that gives a recombination frequency of 1%. For map distances up to 35 cM the following equation may be used:

$$\text{cM} = \frac{100}{2} \left(\frac{\text{T} + 6\text{NPD}}{\text{PD} + \text{NPD} + \text{T}} \right)$$

For greater distances, up to 75 cM, a correction has to be made and the following empirically derived calculation is used:

$$\text{cM (corr.)} = \frac{(80.7)(\text{cM}) - (0.883)(\text{cM})^2}{83.3 - \text{cM}}$$

The distance between a gene and its centromere can be determined by measuring the percentage of T tetrads using a marker gene that is known to be tightly linked to the centromere. In this instance, the following formula is used:

$$\text{cM} = \frac{100}{2} \left(\frac{\text{T}}{\text{PD} + \text{NPD} + \text{T}} \right)$$

The proportion of the genome that resides in the nuclear chromosomes is described as being Mendelian since recombination events proceed according to Mendelian rules of inheritance. Other elements of the genome such as that found in mitochondria can also be detected by tetrad analysis. For example, non-Mendelian inheritance is observed for any character that is coded for by non-chromosomal DNA.

Identification of a gene associated with a particular mutation can be accomplished by genetic complementation studies. This involves producing a range of diploid crosses by mating a haploid bearing the uncharacterized mutation with a range of characterized haploid mutants with the same phenotype as the test strain. A control diploid is produced using the test mutant and a normal wild type strain. The normal wild type phenotype in the control heterozygote confirms that the unknown mutation is recessive. The heterozygous cross that produces the mutant phenotype must be double recessive and therefore contains the same mutation as the unknown. All other heterozygotes lose the original mutant phenotype indicating that the uncharacterized mutation was not present in any of the control test strains.

The development of recombinant DNA technology has revolutionized the ease by which the yeast genome may be analysed and manipulated. Very powerful and precise techniques are now available that allow detailed analysis of the genome. Individual genes can be targeted, modified and transferred between cells to facilitate the study of the relationships between genotype and phenotype. It is now relatively simple to introduce foreign DNA into a cell to effect desirable changes in the phenotype. Detailed and rapid genetic analyses provide convenient and precise methods for strain identification – so-called genetic fingerprinting.

Many and varied techniques have been developed. They share some common themes. Unlike classical genetic techniques, DNA is extracted and manipulated in isolation. In order to work with complex mixtures of DNA it is necessary to have methods of separation, enrichment and identification. In a DNA molecule, each gene is encoded by a unique sequence of bases. In single stranded form, this sequence can be targeted providing a probe is available that contains the complementary sequence. Occasionally, the DNA sequence of interest may constitute a very small proportion of the whole. Methods are available, which allow specific fragments to be selected and duplicated *in vitro*. In recent years, much effort has been directed towards identifying the base sequences of entire genomes. The enormous magnitude of this task has necessitated the development of automatic sequencing equipment. The prize is the ability to identify any gene within the genome. The structure of the protein expressed by the gene can be manipulated. Artificial genes can be created *in vitro*.

Electrophoretic characterization of mixtures of DNA is achieved by loading onto a

permeable gel made from a material such as polyacrylamide or agarose. The gel is submersed in an electrolyte and an electric current is applied. DNA molecules are charged molecules and in the electrical field, they migrate between electrodes. The extent of migration is dependent on molecular size and charge. Several different electrophoretic techniques are used which allow separation of different ranges of DNA molecule. These may range from whole chromosomes to small DNA fragments a few bases in length.

Whole chromosomes can be separated using pulse field electrophoresis. Chromosomes can be visualized by staining with ethidium bromide and viewing under ultraviolet light. This procedure is termed karyotyping. It is used as a method of strain identification and to probe chromosome stability. More typically, the extracted DNA is broken into fragments using enzymes termed restriction nucleases. The latter are a large family of bacterial enzymes that break DNA molecules at particular known recognition sequences. The fragments can be separated by gel electrophoresis. In the technique termed Southern blotting, the separated fragments of DNA are transferred to a nylon or nitrocellulose membrane. During the process, the double-stranded DNA molecules are denatured to give single strands on the nylon sheet. The presence of specific DNA sequences can be detected by treating the membranes with probes consisting of complementary strands of DNA attached to a visualizing system. The latter may be a radioactive label or a dye such as a fluorochrome.

This procedure can be used as a method of strain identification in the technique termed restriction fragment length polymorphism (RFLP). Providing the complementary DNA probe is available it can be used to detect the presence of any gene within the test organism. The same approach can be used to probe mixtures of RNA molecules. In this case, termed Northern blotting, mRNA molecules are subject to electrophoresis. Specific RNA sequences are detected using a probe, which is a single strand of DNA.

In many cases, it is necessary to enrich extracted DNA to increase the yield of particular genes of interest. This process is termed amplification and it can be accomplished in several ways. It can be performed *in vitro* using DNA polymerase, the enzyme that is responsible for DNA replication in the cell. The technique is known as PCR, from polymerase chain reaction. The extracted target DNA is denatured by heating and each single strand attached to a suitable primer. The latter is a short nucleotide sequence that targets the DNA of interest, such that any that is attached to the primer is duplicated. The entire duplication process takes just a few minutes. Repeated cycling allows multiple copies of the genes of interest to be made. In a short time, this amplification process results in several million copies of the original DNA being manufactured. PCR can be used to amplify the DNA fragments formed in the restriction fragment length polymorphism (RFLP) approach to strain identification. This combination of methods, termed amplified fragment length polymorphism (AFLP) increases the sensitivity of the genetic fingerprint.

Exogenous DNA fragments can be introduced into a cell and thereafter inherited and expressed with the cell's own genome, a process termed transformation. DNA may be introduced directly by first converting the target cell into a sphaeroplast. This is accomplished by enzymic removal of the cell wall in the presence of an osmotic stabilizer. Incubation of sphaeroplasts and DNA on solid media containing osmotic stabilizers provide conditions under which transformation and re-growth of the cell wall can occur. Newer procedures obviate the need for removal of the cell wall. For example, cell walls can be made permeable to DNA by treatment with lithium acetate. Alternatively, cell membranes can be made temporarily permeable to DNA by application of an electrical field in the process of electroporation. Exogenous mitochondrial DNA can be introduced into the mitochondria of host cells by high-

velocity bombardment. In this case, the DNA is contained within a tungsten micro-projectile, which is fired into the mitochondrion using compressed air.

The most usual method of introducing exogenous DNA into a cell is via the intermediary of a vector. These are small pieces of circular DNA termed plasmids. The DNA fragment of interest is integrated into the plasmid DNA. They have several advantages as transforming agents compared to the use of pure DNA. Several different plasmids are available which can be used to accomplish several different functions. These include insertion, deletion, alteration and expression of genes. All have marker genes so those host cells containing the plasmid can be selected. Commonly, they bear genes conferring resistance to selected antibiotics. Plasmids are usually of the shuttle type, referring to the fact that apart from being able to maintain themselves in yeast cells they have an origin of replication that allows generation of a high copy number in an alternative host such as *E. coli*.

The ability to grow the plasmid in a bacterium provides a convenient method of gene amplification. When introduced into a yeast cell some plasmids integrate into a chromosome whilst others are able to replicate autonomously. These differences are utilized in different gene manipulations. For example, integrative types might be used where a very stable transformation is required. Conversely, autonomously replicating types may be used where very high copy numbers of the transforming gene are needed. Plasmids can be used to perform a number of tasks. They afford the most precise way of identifying a mutant gene. Thus, mutant cells are transformed with plasmids bearing a library of fragments of the wild type genome. Any cells with the wild type phenotype must contain a functional copy of the gene on the plasmid. The latter can be recovered and analysed for the presence of the appropriate gene. Similar procedures can be used to introduce a selected gene into a cell or to disrupt a chosen gene within a cell.

The sequence of bases in DNA molecules can be determined. In order to deal with whole genomes, the enormous number of bases involved requires that processes are automated. Robotic samplers and automatic analysers are now available. Typically, the shotgun sequencing approach has been used. In this method, the genome is cut into a large number of random fragments. The sequence of each fragment is determined. Using the fast and relatively inexpensive computational power now available, the sequence of the whole can be deduced from those of the fragments.

The entire genome of *S. cerevisiae* has now been sequenced and the DNA corresponding to each identified chromosomal gene is available in the form of a library. Pieces of apparatus termed arrayers have been developed that transfer, or print, individual polynucleotide samples corresponding to each gene onto a membrane. Each sample dot is approximately 100–200 μm in size and arranged on a membrane in the form of a grid. The loaded grids hold the entire chromosomal genome. They are termed variously as DNA microarrays, DNA chips or gene chips. The oligonucleotides on the grids can be probed by hybridization with other samples of DNA. The probes are attached to fluorescent dyes and hybridization can be visualized by confocal microscopy. Using this system, the DNA probe mixture can be prepared by reverse transcriptase from the entire mRNA content of the strain under investigation. By testing on a DNA array containing the original DNA genome of the strain, the relative expression of the whole genome can be assessed.

11.8.2 The yeast genome

Haploid cells of *S. cerevisiae* contain 16 chromosomes, ranging in size from 200 to 2200 kb. All have been sequenced and 1996 saw publication of the complete sequence of

the entire genome of a strain of *S. cerevisiae* (Goffeau *et al.*, 1996). The magnitude of this task is reflected by the fact that in the case of *S. cerevisiae*, some twelve million nucleotide bases were sequenced. Comparison of this sequence with those obtained from other cells and with knowledge of gene structure allows identification of sequences that encode for specific proteins. Such sequences are termed open reading frames (ORFs). Some 6,217 potential open reading frames have been identified in the yeast genome (Mewes *et al.*, 1997). Of these 6,217 potential proteins, approximately half have been positively identified based on known sequences. A further 20% have a putative identification and the remaining 30%, the so-called 'orphan genes' have no known function. The positively identified genes have been classified based on cellular function (Table 11.5).

An attempt to gain an understanding of the function of orphan genes is being addressed by novel techniques. These involve the construction of mutants in which a single orphan gene is deleted. The phenotype is then examined to determine the metabolic consequences of the deletion. This approach has been termed reverse genetic analysis (Oliver, 1997). It is anticipated that this will culminate in the development of automatic analysis of the proteome in a manner analogous to the DNA array systems described in Section 11.8.1.

Compared to many other cells, the yeast genome is very compact. Approximately 72% of chromosomal DNA codes for actual genes. The average size of yeast genes is 1.45 kb or 483 codons representing 40 to nearly 5,000 codons. Approximately 4% of yeast genes contain introns (non-coding regions). Genes are not evenly distributed throughout the chromosomal DNA, instead there are gene-rich clusters. In haploid strains, approximately half of the genes are duplicated. This has led to the suggestion that this species arose from the fusion of two ancestral diploid strains, each with eight chromosomes. The resultant tetraploid cell was reduced to a 16 chromosome diploid by deletion (Wolfe and Shields, 1997). Yeast chromosomes contain additional DNA known as retrotransposons or Ty elements. Typically, laboratory haploid strains contain up to 30 copies of a number of different retrotransposons. These are related to retroviruses.

Approximately 10% of the yeast genome is located in mitochondria. The mitochondrial genome encodes around 5% of mitochondrial proteins. The wild type mitochondrial phenotype is denoted ρ^+ . Mutants termed ρ^0 lack all mitochondrial DNA. They are viable but lack many components of the electron transport chain and are therefore, respiratory deficient. Mutants that are ρ^0 produce small colonies on solid media and for this reason are termed petites. Petite mutation is relatively common in production brewing (Donnelly and Hurley, 1996). Strains of *S. cerevisiae* contain a variety of other

Table 11.5 Yeast genome analysis of identified genes based on function (Mewes *et al.*, 1997)

Gene function	Proportion of identified genome (%)
Cellular organization and biogenesis	28
Intracellular transport	5
Transport facilitation	5
Protein trafficking	7
Protein synthesis	5
Transcription	10
Cell growth, division and DNA synthesis	14
Energy transduction	3
Metabolism	17
Cell rescue	4
Signal transduction	2

genetic elements. Most contain 2 μ m plasmids, which apparently function solely for their own replication since deletion has no observable effect on the yeast phenotype. Commonly, the cytoplasm of yeast contains viral nucleic acid termed dsRNA. Several types are found of which the M-type encodes for killer toxin.

Much of the work, which has resulted in the current level of understanding of the yeast genome, has been performed on laboratory haploid strains. The genomes of industrial strains are very different. The most notable difference is the fact that brewing yeast strains are polyploid or aneuploid. Commonly, three or four sets of chromosomes are present (triploid, tetraploid). Often the sets of chromosomes are not present in matched sets, rather, one or more chromosomes is present as an extra or one less copy (aneuploid) (Hammond, 1996). Polyploidy has many consequences. The sequenced haploid laboratory strain of *S. cerevisiae* contains a single copy of the genes encoding for the maltose fermenting enzymes, whereas brewing strains typically contain more than ten copies (Meaden, 1996).

Polyploid strains of *S. cerevisiae* may have been selected for in industrial processes since they may have very stable phenotypes. Thus, the chance of a single point mutation having an effect on the phenotype is reduced where multiple copies of the gene are present on other chromosomes. In addition, it is possible that multiple copies of some genes and concomitant increased expression might confer a selective advantage. For example, it has been claimed that multiple copies of maltose utilizing genes produces a phenotype where maltose utilization rates are higher than comparable haploid strains (Hammond, 1996).

No organism has a stable genotype. Mutation and selection provide the mechanism for evolutionary change. Although polyploidy reduces the chances of phenotypic change via mutation, it is not made impossible. Brewing yeast, in common with other fungi, exhibits chromosomal instability. This can be observed by karyotyping (Section 11.8.1). The changes show up as alterations in chromosome length (polymorphism) or even occasionally chromosome deletion. The changes in chromosome length are a reflection of DNA rearrangement and distribution between individual chromosomes (Zolan, 1995). In brewing yeast, it has long been recognized that flocculation properties of individual strains are liable to abrupt shifts during repeated cycles of fermentation, cropping and re-pitching (Gilliland, 1971). Similar observations have been made with a lager yeast strain used in production brewing. Genetic fingerprinting of the non-flocculent and flocculent variants showed differences (Wightman *et al.*, 1996).

11.9 Strain improvement

Industrial strains of yeast, which have been in use for any length of time, will have been selected using empirical criteria. In brewing, for example, individual strains are used because they possess a mix of desirable characteristics. These characteristics ensure that for particular combinations of wort, vessel type and yeast strain produce the desired fermentation performance and beer quality. Greater economic pressures of modern large-scale brewing and the desire to develop new products have provided the impetus to improve strains. Improvement is taken to mean to introduce characters into existing strains such that they acquire an altered phenotype. Some of the potential goals of strain improvement are summarized in Table 11.6.

Traditional genetic approaches for strain improvement involve mating between selected parents and selection of new hybrid offspring containing desirable traits. Alternatively, attempts can be made to select for mutants within a population that have

Table 11.6 Goals for yeast strain improvement

Aim	Strategy
Increased yield of ethanol	Introduction of amylases to allow fermentation of wort dextrins
Increased attenuation rate	Increased concentration of glycolytic enzymes
Very high gravity fermentation	Increased ethanol and osmotolerance
High temperature fermentations	Increased thermotolerance without alteration in production of beer flavour metabolites
Reduced risk of contamination by wild yeast	Incorporation of killer factor
Abolishment of diacetyl stand	Increased flux through valine/isoleucine biosynthetic pathway
Improved control of production of beer flavour metabolites	Incorporation of α -acetolactate decarboxylase
Reduced ethanol yield	Manipulation of pathways for production of esters, H ₂ S, SO ₂
Altered flocculation	Block ethanol production for low/zero alcohol beer production
	Manipulation of Flo genes

desirable characteristics. The frequency of occurrence of mutants can be increased by treatment with mutagens. Brewing yeast strains do not lend themselves to either approach because their polyploid nature makes them relatively resistant to mutation. In addition, they usually lack a sexual cycle and sporulate at best poorly.

It is possible to produce hybrids using rare mating (Spencer and Spencer, 1977; Young, 1981). This procedure is used to produce hybrids of respiratory deficient brewing strains and respiratory sufficient mutant strains. Hybrids are selected by ability to grow on defined media deficient in the nutrient requirement of the mutant but containing an oxidative carbon source. Using this technique, auxotrophic diploids with either *aa* or $\alpha\alpha$ mating alleles have been hybridized with ρ^- brewing strains. The hybrids were capable of sporulating. Providing one of the parents contains the *kar* allele it is possible to produce heteroplasmons. The *kar* allele prevents nuclear fusion and therefore these strains contain somatic elements of both parents with the nucleus of only one parent. This approach has been used to construct brewing strains containing killer factor.

Protoplasts or sphaeroplasts are yeast cells which have had the cell wall removed by treatment with a suitable enzyme preparation. Providing the cells are suspended in an osmotically stabilized medium the sphaeroplasts do not lyse. In the presence of Ca²⁺ ions and polyethylene glycol sphaeroplasts can be induced to fuse and form hybrids (Pesti and Ferenczy, 1982). When sphaeroplasts are incubated on a suitable solid medium cell wall regeneration occurs and stable hybrids are obtained. Hybrids can be selected by ensuring that both parental types are auxotrophic for different nutrients. Only hybrids will grow on a medium that is deficient in both nutrients. The procedure can be used to produce stable tetraploid from diploid parents. It has been largely superseded by more amenable recombinant DNA techniques.

Strain improvement using recombinant DNA technology has the enormous advantage of precision. It is possible to introduce or modify a single gene within the target genome. Several methods may be used to introduce exogenous DNA into a recipient cell producing a phenotype with new and desirable attributes. The methods used are those outlined in Section 11.8.2. Usually the method of choice is one in which the exogenous DNA is introduced in the form of a plasmid vector of the type that forms a stable integrant with the host chromosomal DNA. These techniques have been applied

Table 11.7 Glossary of terms used in genetics

Term	Definition
Allele (syn. allelomorph)	One of a pair of genes located at the same point on homologous chromosomes
Aneuploid	Polyploid strains lacking whole copy numbers of all genes
Ascospore	Haploid spores produced via meiosis in Ascomycetous fungi
Ascus	Spore-bearing body in Ascomycetous fungi
Auxotroph	Mutant with specific nutrient requirement for growth
Bases	Constituent molecules of RNA and DNA whose order form the basis of genetic code. DNA contains adenine and guanine (purines); thymine and cytosine (pyrimidines). In RNA uracil replaces thymine
Biochip	Array of 1000 or more oligonucleotides printed on a solid support. (syn. DNA chip, DNA microarray, gene chip, genome chip) used to identify genes present within a genome
Cdc	Cell division cycle mutants
cDNA	Complementary DNA produced by reverse transcription of mRNA
Centromere	Attachment site of chromosome to spindle body
CHEF	Electrophoresis technique – contour clamped homogeneous electric field
Chromosomes	Structures in which duplex DNA molecules are located
CLP	Chromosome length polymorphism
Codon	Triplet of bases which together code for a single amino acid
Differential expression studies	Study of relative levels of all mRNA in cells in different physiological states (syn. transcriptomics)
Diploid	Organism having two sets of chromosomes
DNA	Deoxyribonucleic acid – macromolecule which forms the genetic code. It consists of a backbone of sugar and phosphate groups to which purine and pyrimidine bases are attached. Two complementary molecules are attached together to form a double helix
LTR	Long terminal repeats – long repeating sequences of bases flanking transposons in genome
Meiosis	Process of reductive division in which diploid nucleus divides with a single replication of DNA to give four haploid spores
Mitosis	Division of nucleus and replication of DNA during asexual cell division
Monosomic	Diploid cell lacking one of a pair of chromosomes
Northern blot	Electrophoretic technique using RNA instead of DNA
ORF	Open reading frame, sequences of DNA flanked by start and termination codons that code for a single protein
Orphan genes	DNA sequences identified as genes but not having recognized function
PCR	Polymerase chain reaction
Plasmid	Small, frequently circular sequence of extra-chromosomal DNA
Probe	Fragment of DNA of known sequence labelled with radioactive phosphorus or fluorochrome used for detection of complementary DNA in mixture
Proteome	Whole set of proteins produced by genome
RFLP	Restriction fragment length polymorphism

Table 11.7 Continued

Term	Definition
Rho ⁻ (syn. ρ^-)	Mutant lacking mitochondrial genome
RNA	Ribonucleic acid – macromolecule consisting of a backbone of phosphate and sugar molecules to which purines and pyrimidines are attached. RNA exists in several functional forms: mRNA – messenger RNA, single stranded form which is synthesized during transcription of DNA. Provides template for amino acid synthesis rRNA – ribosomal RNA, ribonucleic acid component of ribosomes, which mediate the process of translation of tRNA to form protein molecules tRNA – transfer RNA, family of molecules which bind individual amino acids and transfer them to the ribosomes as directed by the codons on the mRNA molecule snRNA – small nuclear RNA molecules that mediate post-translational processing of mRNA
Sequence	Order of nucleotide bases within molecules of DNA or RNA that collectively form the genetic code
SDS-PAGE	Sodium dodecyl sulphate polyacrylamide gel electrophoresis. Gel electrophoresis separation technique for proteins. SDS causes dissociation of multimeric proteins
Sporulation	Spore formation. In <i>S cerevisiae</i> , ascospores are formed during meiotic division
Southern blot	Electrophoresis of DNA on gel followed by denaturation and transfer of single-stranded DNA to membrane. Separated DNA fragments analysed by complementary DNA probes
SSCP	Single stranded confirmational polymorphism – separation technique similar to Southern blotting differing in that it relies on the migrational characteristics of single-stranded DNA
TAFE	Electrophoretic technique – transverse alternating field electrophoresis
Telomere	Sequences of bases at end of eukaryotic chromosomes important for ensuring correct replication of terminal segments of DNA molecules
Tetraploid	Cell possessing four sets of chromosomes
Transcription	Synthesis of molecule of mRNA using single-stranded DNA molecule as template
Translation	Synthesis of polypeptide in ribosome using mRNA as template
Transposon (transposable element)	Sequence of DNA that is capable of movement within or between chromosomes (see Ty elements)
Triploid	Cell with three sets of chromosomes
Trisomic	Diploid cell containing three copies of one chromosome
Ty elements	DNA elements that are classified as long terminal repeat (LTR)-containing retrotransposons. These are retroviruses
Western blot	Technique similar to Southern and Northern blot for electrophoretic separation and detection of proteins
Zygote	Stage in sexual reproduction comprising the diploid cell formed from the fusion of two haploid cells of opposite mating type

successfully to brewing yeast strains. Recombinant yeast strains have been constructed which meet many of the needs outlined in Table 11.6 (Hammond, 1995).

No yeast strains produced by recombinant genetic modification are used in production brewing even though one has been given approval for use by the United Kingdom regulatory authorities (Hammond, 1995). At present, at least within Europe, there is an extreme reluctance to accept genetically modified foods. Understandably, in this climate, commercial brewers are unwilling to risk the use of such yeast strains. Whether this situation will be transient or long lasting is unclear. It has had the result that development work in this area has been largely discontinued. Recombinant DNA technology continues to afford the most fruitful approach probing the secrets of the genome. Undoubtedly, within the short term considerable advances will continue to be made.

11.10 References

- ANDERSON, R. G. (1995) *25th Cong. Eur. Brew. Conv., Brussels*, 13.
- ARIAS, C. R., BURNS, J. K., FRIEDRICH, L. M., GOODRICH, R. M. and PARISH, M. E. (2002) *Appl. Environ. Microbiol.*, **68**, 1955.
- ARNOLD, W. N. (1991) *Periplasmic space*. In *The Yeasts*, Vol. 4, 2nd edn, A. H. Rose and J. S. Harrison eds, pp. 279–295, Academic Press, London.
- ARVINDEKAR, A. U. and NARAYAN, B. P. (2002) *Yeast*, **19**, 131.
- BACALLAO, R. and STELZER, E. H. K. (1989) *Meth. Cell Biol.*, **31a**, 454.
- BALDWIN, W. W. and KUBITSCHKE, H. E. (1984) *J. Bacteriol.*, **158**, 701.
- BARKER, M. G. and SMART, K. A. (1996) *J. Amer. Soc. Brew. Chem.*, **54**, 121.
- CAHILL, G., WALSH, P. K. and DONNELLY, D. (1996) *J. Amer. Soc. Brew. Chem.*, **57**, 72.
- CHAPMAN, A. C. (1931) *J. Inst. Brewing*, **37**, 433.
- CORRAN, H. S. (1975) *A History of Brewing*. David & Charles, London.
- COX, B. S. (1995) 'Genetic analysis in *Saccharomyces cerevisiae* and *Schizosaccharomyces pombe*'. In *The Yeasts*, Vol. 6, 2nd edn, A. E. Wheals, A. H. Rose and J. S. Harrison eds, pp. 7–67.
- CURTIS, N. S. (1971) *Brewers' Guardian*, September, 95.
- DE SOUZA PEREIRA, R., PARIZOTTO, N. A. and BARANAUSKAS, V. (1996) *Appl. Biochem., Biotechnol.*, **59**, 135.
- DENGIS, P. B., NELISSEN, L. R. and ROUXHET, P. G. (1995) *Appl. Environ. Microbiol.*, **103**, 257.
- DICKINSON, J. R. (1988) *Microbiol. Sci.*, **5**, 121.
- DONNELLY, D. and HURLEY, J. (1996) *Ferment*, **9**, 283.
- EDDY, A. A. (1958) 'Aspects of the chemical composition of yeast'. In *The Chemistry and Biology of Yeasts*, A. H. Cook, ed., pp. 157–249, Academic Press, London.
- FLEET, G. H. (1991) 'Cell Walls'. In *The Yeasts*, Vol. 4, 2nd edn, A. H. Rose and J. S. Harrison eds, pp. 199–277, Academic Press, London.
- FLORKIN, M. (1972) 'A History of Biochemistry', in *Comprehensive Biochemistry*, **30**, 129.
- FORGET, C. (1988) *A Dictionary of Beer and Brewing*, Brewers' Publications, Colorado, USA.
- GALLITSKI, T., SALDANHA, A. I., STYLES, C. A., LANDER, E. S. and FINK, G. R. (1999) *Science*, **285**, 251.
- LILLILAND, R. B. (1971) *Brewers Guardian*, **Oct.**, 29.
- GOFFEAU, A., BARRELL, B. G. and BUSSEY, H. (1996) *Science*, **274**, 546.
- GREUTER, W., BARRIE, F. R., BURDET, H. M., CHALONIER, W. G., DEMOULIN, V., HAWKSWORTH, D. I., JÖRGENSEN, P. M., NICOLSON, D. H., SILVA, P. C., TREHANNE, P. and MCNEILL, J. (1996) *International Code of Botanical Nomenclature*, Koelz Scientific Books, Königstein, Germany.
- HAMMOND, J. R. M. (1995). *Yeast*, **11**, 1613.
- HAMMOND, J. R. M. (1996). *Yeast Genetics*, In *Brewing Microbiology*, 2nd edn, F. G. Priest and I. Campbell, eds, pp. 43–82, Chapman and Hall, London.
- HAROLD, F. M. (1995) *Microbiology*, **141**, 2765.
- HAWKSWORTH, D. L. (1991) *Mycological Res.*, **95**, 641.
- HERSKOWITZ, I., RINE, J. and STRATHERN, J. N. (1992) 'Mating-type determination and mating-type interconversion in *S. cerevisiae*'. In *The Molecular Biology of the Yeast *Saccharomyces cerevisiae**, Vol. 2 *Metabolism and Biosynthesis*, J. N. Strathern, E. W. Jones and J. R. Broach eds, pp. 583–656. Cold Spring Harbor Laboratory, USA.
- ISERENTANT, D. (1996) *Cerevisia*, **21**, 30.
- JIN, Y. L. and SPEERS, A. (1998) *Food Res. Internat.*, **31**, 421.
- JÖRGENSEN, A. (1900) *Micro-organisms and Fermentation*, 3rd edn. Translated by A. K. Miller and A. E. Lennholm, Macmillan, London.

- KING, F. A. (1947) *Beer Has a History*, Hutchinson's Scientific and Technical Publications, London.
- KLIONSKY, D. J., NELSON, H. and NELSON, N. (1992) *J. Biol. Chem.*, **267**, 3416.
- KURTZMAN, C. P. and FELL, J. W. (1998) *The Yeasts, A Taxonomic Study*, 4th edn, (C. P. Kurtzman and J. W. Fell eds., Elsevier, Amsterdam, Netherlands).
- LAWRENCE, D. R., BOWEN, W. R., SHARPE, F. R. and VENTHAM, T. J. (1989) *Proc. 22nd Cong. Eur. Brew. Conv., Zurich*, 505.
- LEATHER, R. V., DALE, C. J. and MOROSON, B. T. (1997) *J. Inst. Brewing.*, **103**, 377.
- LEBER, R., ZINSER, E., ZELLNIG, G., PALTAUF, F. and DAUM, G. (1994) *Yeast*, **10**, 1421.
- LLOYD, D. and CARTLEDGE, T. G. (1991). 'Separation of yeast organelles', in *The Yeasts*, 2nd edn, vol 4, A. H. Rose and J. S. Harrison eds, pp. 121–174, Academic Press, London.
- LODDER, J. (1970) *The Yeasts, a Taxonomic Study*, 2nd edn, North Holland Publishing Company, Amsterdam, Netherlands.
- MEADEN, P. (1996) *Ferment*, **9**, 213.
- MESTDAGH, M. M., ROUXET, P. G. and DUFOUR, J. P. (1990) *Ferment*, **3**, 31.
- MEWES, H. W., ALBERMANN, K. and BARR, M. (1997) *Nature*, **387** (suppl), 7.
- MIKI, B. L. A., POON, N. H., JAMES, A. P. and SELIGNY, V. L. (1982) *J. Bacteriol.*, **150**, 878.
- MONTRONCHER, R., VERNER, M.-C., BRIOLAY, J., GAUTIER, C. and MARMEISSE, R. (1998) *Internat. J. Systematic Bacteriol.*, **48**, 295.
- NARZISS, L. (1984) *J. Inst. Brewing*, **90**, 351.
- NURSE, P. (1975) *Nature*, **256**, 547.
- O'CONNOR-COX, E. S. C., LODOLO, E. J. and AXCELL, B. C. (1996) *J. Inst. Brewing*, **102**, 19.
- OLIVER, S. G. (1997) *Microbiology*, **143**, 1483.
- PESTL, M. and FERENCZY, L. (1982) *J. Gen. Microbiol.*, **128**, 123.
- PHAFF, H. J. and STARMER, W. T. (1987) 'Yeasts associated with plants, insects and soil'. In *The Yeasts* 2nd edn, Vol. 1, A. H. Rose and J. S. Harrison eds, pp. 123–180, Academic Press, London.
- PISKUR, J., SMOLE, S., GROTH, C., PETERSEN, R. F. and PEDERSEN, M. B. (1998) *Internat. J. Systematic Bacteriol.*, **48**, 1015.
- QUAIN, D. E. (1986) *J. Inst. Brewing.*, **92**, 435.
- QUAIN, D. E. (1988) *J. Inst. Brewing.*, **95**, 315.
- REED, G. and NAGODARITHANA, T. W. (1991) *Yeast Technology*, Van Nostrand, USA.
- ROSE, A. H. and HARRISON, J. S. (1971) In *The Yeasts*, A. H. Rose and J. S. Harrison eds, 1st edn, pp. 1–2, Academic Press, London.
- SCHWENCKE, J. (1991) 'Vacuoles, internal membranous systems and vesicles'. In *The Yeasts*, Vol. 4, 2nd edn, A. H. Rose and J. S. Harrison eds, pp. 347–432, Academic Press, London.
- SHAW, S. L., MADDOX, P., SKIBBENS, R. V., YEH, E., SALMON, E. D. and BLOOM, K. (1998) *Molec. Biol. Cell*, **9**, 1627.
- SINGER, S. J. and NICHOLSON, G. L. (1972). *Science*, **175**, 720.
- SMITS, G. J., KAPTEYN, J. C., VAN DEN ENDE, H. and KLIS, F. M. (1999) *Curr. Opinion in Microbiol.*, **2**, 348.
- SPENCER, J. F. T. and SPENCER, D. M. (1977) *J. Inst. Brewing*, **83**, 287.
- STARK, M. J. R. (1999). 'Protein phosphorylation and dephosphorylation'. In *The Metabolism and Molecular Physiology of Saccharomyces cerevisiae* J. R. Richardson and M. Schweizer eds, pp. 209–275. Taylor & Francis, London.
- STEVENS, B. J. (1977) *Biol. of the Cell*, **28**, 37.
- STRATFORD, M. (1992) *Yeast*, **8**, 635.
- STRATFORD, M. (1994) *Yeast*, **10**, 1741.
- STRATFORD, M. and ASSINDER, S. (1991) *Yeast*, **7**, 559.
- TAKITA, M. A. and CASTILHO-VALAVACIUS, B. (1993) *Yeast*, **9**, 589.
- TAMAI, Y., MOMMA, T., YOSHIMOTO, H. and KANEKO, Y. (1998) *Yeast*, **14**, 923.
- TEUNISSEN, A. W. R. H. and STEENSMA, H. Y. (1995). *Yeast*, **11**, 1001.
- VAUGHN-MARTINI, A. and MARTINI, A. (1993) *Systematics and Appl. Microbiol.*, **16**, 113.
- VISSER, W., VAN SPONSEN, E.A., NANNINGA, N., PRONK, J. T., KEUNEN, J. G. and VAN DIJKEN, J. P. (1995) *Antonie van Leeuwenhoek.*, **67**, 243.
- WIGHTMAN, P., QUAIN, D. E. and MEADEN, P. (1996) *Lett. Appl. Microbiol.*, **22**, 85.
- WILLIAMSON, D. H. (1991) 'Nucleus, Chromosomes and Plasmids'. In *The Yeasts*, Vol. 4, 2nd edn, A. H. Rose and J. S. Harrison eds, pp. 433–488, Academic Press, London.
- WOLFE, K. and SHIELDS, D. (1997) *Nature*, **387**, 708.
- YOUNG, T.W. (1981) *J. Inst. Brew.*, **87**, 292–295.
- YOUNG, T.W. (1987) 'Killer Yeasts'. In *The Yeasts*, vol. 2, 2nd edn, A.H. Rose and J.S. Harrison eds, pp. 131–164, Academic Press, London.
- ZOLAN, M. E. (1995) *Microbiol. Rev.*, **59**, 686.

12

Metabolism of wort by yeast

12.1 Introduction

The biochemical reactions that occur during fermentation represent the cumulative effects of the growth of yeast on wort. The disappearance of nutrients and the formation of ethanol, carbon dioxide and the other metabolites, which together contribute to beer, are all by-products of yeast growth. Wort is complex and not completely characterized. Similarly, the reactions which occur during fermentation are not fully characterized. The biochemistry of *S. cerevisiae* has been subject to intensive study. However, the majority of these studies involved laboratory strains growing under aerobic conditions, often on defined media. The literature describing the biochemistry of the metabolism of wort by brewing yeasts during brewing fermentation is much smaller. Here is provided an overview of the metabolism of *S. cerevisiae*. Where possible the discussion is limited to the metabolism of wort by brewing strains of *S. cerevisiae*. Some aspects of the metabolism of non-brewing strains of yeast are also included where they have relevance as potential spoilage organisms.

Brewing yeast strains are heterotrophic, facultative anaerobes. A comparatively wide spectrum of organic molecules can be oxidized to both generate energy in the form of ATP and simultaneously provide carbon skeletons for anabolic reactions. Depending on the availability of oxygen and the concentration and source of carbohydrate, metabolism may be fully aerobic and oxidative, or fermentative. Thus, brewing yeasts have a relatively versatile metabolism and are able to adapt to a variety of conditions and furthermore, environmental triggers modulate their physiology. The biochemical events that occur during fermentation reflect the genotype of the yeast strain used and its phenotypic expression as influenced by the composition of the wort and the conditions established in the fermenting vessel. In order to obtain satisfactory fermentation performance and beer of a desired quality it is necessary to choose a yeast strain with a suitable genotype and manipulate the conditions to encourage appropriate metabolic behaviour.

All brewing yeast strains have limited respiratory capacities and are subject to carbon catabolite repression (Gancedo, 1992; Section 12.5.8). Under the conditions encountered

during fermentation, this phenomenon ensures that yeast physiology is repressed at all times and, therefore, the major products of sugar catabolism are ethanol and carbon dioxide. The initial concentration and spectrum of fermentable carbohydrates control the concentration of ethanol synthesized during fermentation. The range of carbohydrates that the yeast is able to ferment and the maximum concentration of ethanol that it can tolerate are genetically determined. These factors are criteria used in the selection of yeast strains used in brewing.

Besides ethanol and carbon dioxide, a multitude of other minor products of yeast metabolism are formed during fermentation. Many of these contribute to beer flavour and aroma. The production of a desired spectrum of flavour and aroma compounds constitutes another selection criterion for yeast strains, albeit with the caveat that fermentation conditions must be controlled properly to ensure that these minor metabolic by-products are synthesized in desired and consistent quantities.

In the vast majority of breweries fermentation is a batch process. Usually, the pitching (inoculum) yeast is derived from a previous fermentation. This practice has many ramifications, some of which influence the metabolism of wort by yeast. Most notably, it provides a requirement to oxygenate wort. Molecular oxygen is necessary for the synthesis of sterols and unsaturated fatty acids. These are essential components of membranes and are a prerequisite for yeast growth under anaerobic conditions (Parks, 1978; Section 12.6). A single dose of oxygen is supplied with the wort at the start of fermentation and this is used for the synthesis of sterol and unsaturated fatty acids. During the subsequent anaerobic phase of fermentation, the pre-formed pools of these metabolites, together with a small quantity of lipid supplied with wort, are progressively diluted amongst daughter yeast cells. In the yeast crop obtained at the end of fermentation, sterol and unsaturated fatty acid levels are reduced to growth-limiting concentrations, hence, the need for oxygenation of wort in the next fermentation.

At the end of fermentation, it is necessary to separate the yeast crop from the immature ('green') beer. This is facilitated by the design of the fermenting vessel and the flocculation characteristics of the yeast. Bottom-fermenting yeasts sediment to the base of the vessel at the end of fermentation, whereas top-fermenting types form a crop at the surface of the fermenting wort. Fermenter design must accommodate harvesting of each type of yeast. Typical high-gravity lager wort with a specific gravity of 1.060 contains approximately 150 g/l fermentable sugar and 150 mg/l free amino nitrogen. At the start of fermentation, the wort is oxygenated to achieve a dissolved concentration within the range 15–25 mg/l. It is pitched with yeast at a rate of around 1 g dry wt./l, equivalent to roughly 5 g wet wt./l or $12\text{--}15 \times 10^6$ cells/ml. During fermentation, the yeast concentration increases around five-fold. Yeast growth is accompanied by the formation of roughly 45 g/l ethanol and 42 g/l carbon dioxide. The conversion of sugars to ethanol is about 85% of the theoretical. The shortfall represents the proportion of wort sugars utilised for yeast biomass formation and other metabolites. The yield of carbon dioxide is marginally less than that of ethanol since some of the former is fixed by yeast in carboxylation reactions. Growth of yeast on wort is an exothermic process and it is necessary to apply cooling during fermentation to dissipate heat. The changes in some key parameters during a high-gravity lager fermentation of this type are shown in Fig. 12.1.

The practice of serial fermentation, cropping and re-pitching introduces a requirement for yeast storage in the intervals between fermentations. The duration of the storage phase and the conditions employed influence yeast physiological condition. In particular, the intracellular concentrations of storage carbohydrates (glycogen and trehalose) and sterols and other lipids can be influenced. Variations in the concentrations of these metabolites

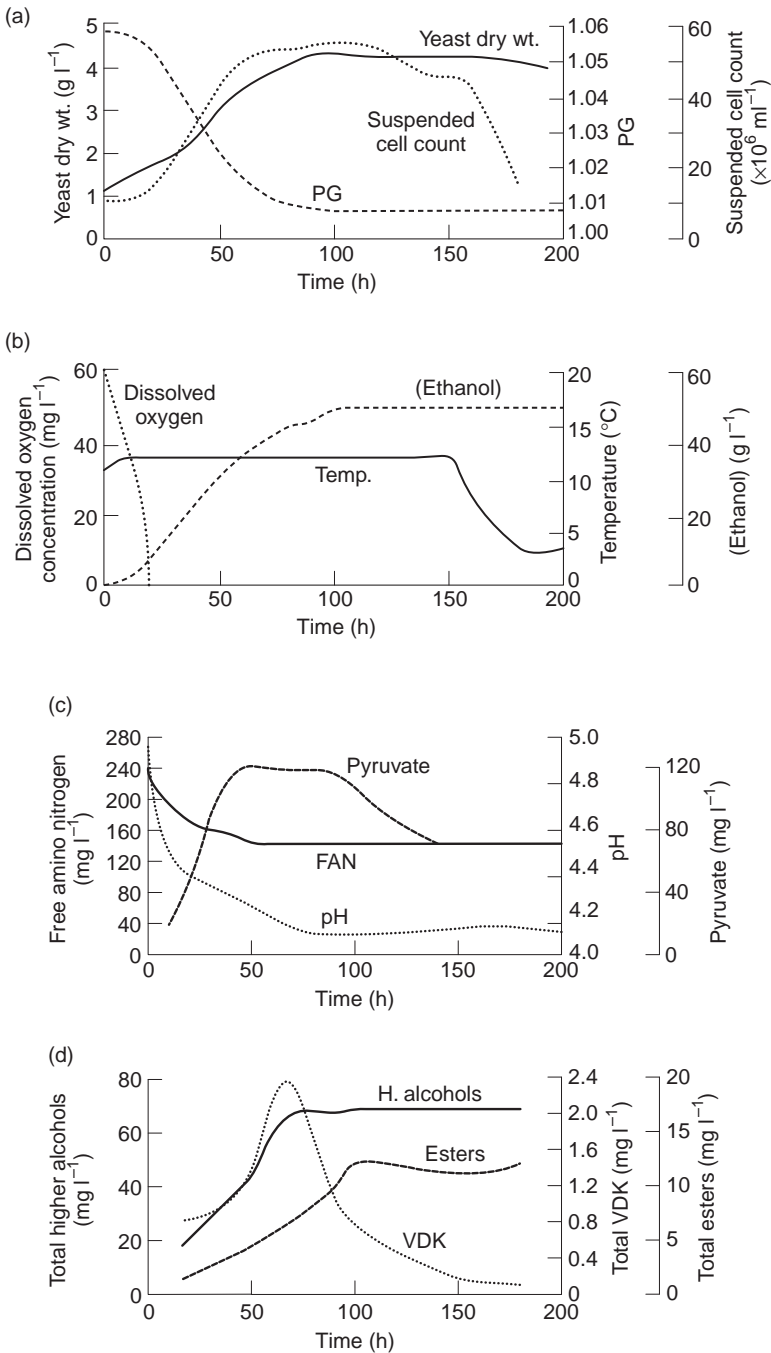

Fig. 12.1 Changes in present gravity (PG), yeast dry weight, suspended yeast cell count (a); ethanol concentration, temperature, dissolved oxygen concentration (b); free amino nitrogen concentration (FAN), pH, pyruvate concentration (c); total vicinal diketones (VDK), total higher alcohols, total esters (d) during the fermentation of a high-gravity (15°Plato) lager wort performed in a 1600 hl cyclindroconical fermenter. The fermentation was maintained at a temperature of 12 °C. The process was terminated after approximately 150 h by cooling the green beer to 3 °C.

in pitching yeast are a cause of inconsistencies in the extent of growth during subsequent fermentation. *Ipsa facto*, the conditions under which pitching yeast is stored should be such that the opportunity for physiological variability is minimized.

The physiological state of pitching yeast is an important determinant of fermentation performance. Compared with other fermentations, pitching rates are comparatively high and growth extents are modest. The pitched yeast plays an active role in subsequent fermentation and a proportion may persist through to the crop and be subject to further rounds of storage and re-pitching. In a modern brewery, it is usual to limit the number of serial fermentations. When the permitted number of generations is reached, the yeast is discarded and a new pure culture is introduced into the brewery (Chapter 11). This practice necessitates the use of a pure yeast culture plant and a system for maintaining and cultivating reference cultures in the laboratory. A feature of this approach is that a number of yeast 'lines' of varying generational age will be in use at any given time.

The influence of serial cropping and re-pitching on the consistency of fermentation performance and beer composition is unclear. Yeast cells undergo a process of ageing, senescence and death. The ageing process in yeast is associated with a gradual disruption of many metabolic processes (Jazwinski, 1999). Depending on the type of fermenter, serial fermentation can select for a sub-population enriched with elderly cells.

12.2 Yeast metabolism – an overview

Metabolism is the sum of all the chemical processes occurring in a cell. The manifestations of metabolism are the disappearance of nutrients from the medium and the appearance of by-products, of heat, the growth of individual cells and cell proliferation. These processes are accomplished by sequences of individual chemical reactions, which together form pathways. Each reaction is catalysed by functional proteins, termed enzymes. Metabolism is divided into two areas. Catabolism includes those pathways in which organic molecules are degraded with the liberation of energy. Anabolism is that part of metabolism in which the energy formed by catabolic pathways is utilized to fuel the synthetic reactions required for cellular growth and multiplication. Enzymes and other proteins are synthesized as a result of the expression of individual genes (Chapter 11)

Carbohydrates are the preferred sources of carbon and energy in yeast. The oxidation of carbohydrates liberates energy, furnishes reducing power and generates carbon intermediates. Some carbon intermediates, together with other non-carbohydrate nutrients, are utilized in anabolic metabolism to generate cellular biomass and by-products. The energy is partly conserved in the form of the high-energy phosphate bonds of a group of metabolites, principally adenosine triphosphate (ATP, **4.53**). Cleavage of these bonds liberates the stored energy and this is used to drive processes such as active transport and anabolic metabolism and to generate heat.

Reducing power is transferred using the pyridine dinucleotide coenzymes, nicotinamide adenine dinucleotide (NAD^+ , **4.54**) and to a lesser extent nicotinamide adenine dinucleotide phosphate (NADP^+ , **4.54**). These compounds function as electron acceptors in reactions with oxidoreductase enzymes. In these reactions, two hydrogen atoms are removed from the substrate. One is released as a hydrogen ion and the second is transferred as a hydride ion to the nicotinamide portion of the coenzyme. The resultant reduced coenzyme (NAD(P)H) is then available to reduce a substrate and the oxidized form of the coenzyme is regenerated.

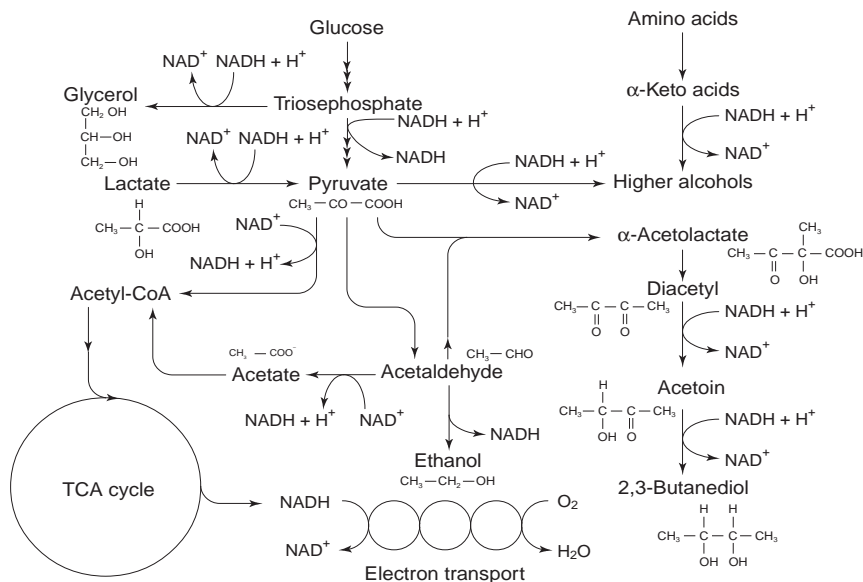

Fig. 12.2 Some redox-balancing reactions utilizing the coenzyme, nicotinamide adenine dinucleotide (NAD^+). For clarity many reactions in the sequences of reactions have been omitted.

An essential of cellular metabolism is the requirement to maintain redox balance. The oxidation reactions of carbohydrate dissimilation generate reduced pyridine nucleotides. The cell has a finite pool of pyridine nucleotides. In order to maintain activity of the glycolytic pathways the cell must ensure a supply of oxidized pyridine nucleotides. The ways in which this is accomplished do much to explain why certain products of metabolism accumulate (Fig. 12.2). Thus, in fully aerobic oxidative growth, NADH is reoxidized via the electron transport chain, which indirectly drives oxidative phosphorylation (Section 12.5.4). In this case the terminal electron acceptor is oxygen and water is formed. During fermentative growth, the oxidative pathways are inoperative and NAD^+ has to be regenerated by the reduction of acetaldehyde to ethanol (Section 12.5.5).

A proportion of the carbon metabolite flow through the carbohydrate dissimilatory pathways is diverted into anabolic biosynthetic pathways and so this material is not available to the terminal redox-balancing reactions and other mechanisms come into play. The most often quoted is the formation of glycerol, via glycerol phosphate from dihydroxyacetone phosphate, although the formation of this metabolite is also considered a response to osmotic stress (Section 12.3.1). During brewery fermentations, several other options are also possible. For example, the terminal reductive step in the formation of higher alcohols from aldehydes and ketones derived from amino acids and the reduction of vicinal diketones. Most of these products of fermentation are important contributors to beer flavour.

Metabolism is highly regulated. Control is exerted by the regulation of enzyme and protein synthesis (gene level) and enzyme activity (phenotypic level). Spatial considerations are also important. Individual metabolic pathways are commonly localized in specific intracellular membrane-bound compartments. Transport of substrates to and from these cellular compartments can control the activity of these pathways. Enzymes within a given cellular compartment probably have specific spatial relationships with one another and this too has regulatory significance.

Control at the phenotypic level is achieved by varying enzyme concentration and activity. Enzyme activity can be modulated by metabolites or proteins that exert stimulatory or inhibitory effects. These metabolites can be substrates or products of the enzyme in question. Alternatively, metabolites that are neither substrates nor products can alter enzyme activity by bringing about structural alterations, a process termed allosteric modulation.

Some genes, termed constitutive, are always expressed and their protein products are present in the cell under all conditions. Other genes are expressed only under certain conditions. The control of the expression of these inducible genes may be simple. For example, the presence of a given nutrient in the medium, e.g., maltose, commonly induces the expression of the genes which encode for the carriers (permeases) required for its transport into the cell and the enzymes involved in its subsequent utilization. Conversely, the accumulation of a nutrient that is the product of an anabolic pathway often causes repression of the gene's coding for the proteins required for its synthesis.

Other control mechanisms influence both gene expression and enzyme activity in a coordinated fashion. These metabolic signal transduction systems have far-reaching effects on metabolism and are of fundamental importance in explaining why and how yeasts respond to different environmental stimuli (Thevelein, 1994). In these metabolic control systems one, or a small number, of exogenous triggering chemical compounds in the medium interact with specific targets within yeast cells. This initial interaction sets in motion a series of metabolic events in which several enzymes and transport permeases may be activated or inactivated. Simultaneously, the expression of several genes may be induced or repressed. Thus, exposure of yeast to a single metabolite has the potential to alter several facets of its physiology. Conversely, a number of different exogenous triggers may activate a common pathway. Several signal transduction pathways are known to operate in yeast cells and, no doubt, more will be identified in the future. Often, there is overlap between signal transduction pathways. The regulation of individual pathways is organized in a hierarchical fashion such that activation and inhibition is ordered with respect to time. In this way, the cell organizes metabolic activity to suit any particular set of environmental conditions.

Signal transduction pathways are commonly mediated by the phosphorylation or dephosphorylation of target proteins in response to the activities of specific protein kinases and phosphoprotein phosphatases (Stark, 1999). The attachment of a phosphate group to susceptible proteins leads to a reversible structural modification in which the catalytic activity can be eliminated or enhanced. Often, the direction of flow through a metabolic pathway is regulated by pairs of enzymes whose activity is modulated by phosphorylation or dephosphorylation (Fig. 12.3). The importance of protein phosphorylation in the control of cellular metabolism is emphasized by the fact that some 120 protein kinases have been identified in *S. cerevisiae*, accounting for 2% of the genome.

12.3 Yeast nutrition

Some chemical components present in the wort or other medium surrounding yeast cells may be used as nutrients, some may be toxic or growth-suppressing, others may have no effect whatsoever. In some cases, the same component may be a nutrient at a low concentration or toxic at a higher concentration. Some substances are assimilated only under particular cultural conditions. Major classes of nutrients such as sources of carbon

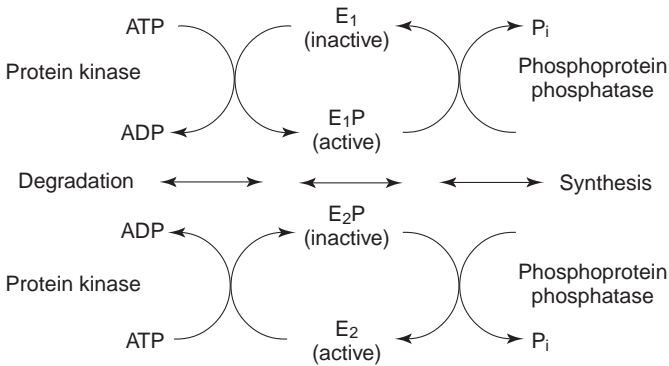

Fig. 12.3 A representation of a system for the regulation of flow through a metabolic pathway, in the direction of biosynthesis or breakdown, using reversible phosphorylation and dephosphorylation. E₁ = enzyme 1, E₁P = Phosphorylated enzyme 1, E₂ = enzyme 2, E₂P = phosphorylated enzyme 2.

and nitrogen are assimilated in an ordered fashion. Thus, where several sources of carbon and nitrogen are present yeast first utilizes those which are most readily assimilated.

12.3.1 Water relations

All yeasts require an aqueous medium for growth. The concentration of available water elicits different responses in individual strains. The available water, or water activity (a_w), is an inverse function of the concentration of solutes present in the medium. Media with low water activities (high solute concentrations) are stressful and only a limited number of yeast strains can tolerate these conditions. It is difficult to distinguish between the effects due solely to water availability and those in which the nature and concentration of the solutes are the predominant influences. A solute may exert a specific biochemical influence on the physiology of the yeast. Neutral solutes exert a general osmotic stress, whereas charged species introduce an additional electrochemical factor. The way in which the stress is applied is also important. A very rapid change in the water activity of the medium has the greatest potential for damage.

The multiplicity of mechanisms by which water activity may influence yeast physiology has resulted in a complicated and confusing system of nomenclature. Strains which can grow in media with low water activities and where this parameter alone is considered to be the major influence, are said to be xerotolerant. The term osmotolerance is used where the osmotic effect due to dissolved solutes is considered most important. Both of these terms describe strains that can tolerate extreme conditions but prefer a medium with a more moderate water activity. The descriptor, osmoduric is also used for such strains. Rarely, some strains grow best in media with a low water activity. These are classified as being osmophilic or xerophilic.

Yeast strains, which can tolerate low water activity conditions, include *Debaromyces hansenii*, *Hansenula anomola*, *Pichia ohmeri*, *Schizosaccharomyces pombe*, *Torulopsis candida*, *Zygosaccharomyces rouxii* and *Zygosaccharomyces bisporus* (Rose and Harrison, 1995). In terms of brewing, all of these are 'wild' yeast strains.

Some marine strains of *Metschnikowia* have been described which are reportedly obligate osmophiles (Phaff *et al.*, 1978). *Z. rouxii* is of importance in brewing since it is the most common cause of microbial spoilage of concentrated sugar syrups. *S. cerevisiae*

is not considered to be xerotolerant. This 'deficiency' places an upper limit on the concentration of wort that can be used. However, *S. cerevisiae* can withstand dehydration. Yeast used for baking and wine making is routinely supplied in a dried form and this technique has now been extended to brewing yeast (Fels *et al.*, 1999). The dehydration process results in morphological changes. The cells take on a shrunken appearance and the plasma membranes develop deep invaginations (Rapoport *et al.*, 1995). These changes are reversed during rehydration. Survival rates are low and for successful drying the yeast must have been cultivated under aerobic fed-batch conditions. These cultural conditions are associated with elevated intracellular concentrations of trehalose and sterols, both of which probably protect membrane integrity during dehydration (Sections 12.5.7 and 12.7.3).

Yeast responds to changes in the water activity of the suspending medium by transient changes in cellular volume. This depends on a combination of the inherent elasticity of the cell wall and an uncontrolled adjustment in the volume of intracellular water, which occurs in response to alterations in external osmotic potential (Marechal *et al.*, 1995). Following a hyperosmotic shock (suspension in a medium with an osmotic potential higher than intracellular contents), the cells contract then there is a gradual recovery period during which the cellular volume increases and returns to the initial value. Osmotolerant strains are more resistant to uncontrolled water loss following hyperosmotic shock and better able to control cellular volume (Walker, 1998).

Xerotolerant strains withstand the conditions of low water activity by altering intracellular conditions. This is accomplished by the synthesis of neutral polyols such as arabitol, mannitol, erythritol, sorbitol and especially glycerol. These are termed compatible solutes. The physiological adaptation to hyperosmotic shock is termed the osmopressure response. Intracellular accumulation of compatible solutes reduces the difference in osmotic potential between the interior of the cell and the environment. The synthesis of compatible solutes allows the re-establishment of cell volume and aids the stabilization of enzymes and membrane proteins and phospholipids (Mager and Varela, 1993). Xerotolerant strains are able to retain compatible solutes within the cell. Less xerotolerant types, including *S. cerevisiae*, lack this ability and some leakage occurs. *S. cerevisiae* also differs from more xerotolerant species in that following a hyperosmotic shock, the accumulation of glycerol is preceded by the formation of trehalose and accumulation of potassium and sodium ions (Singh and Norton, 1991).

The release or retention of glycerol, in response to changes in osmotic potential, is regulated. In *Z. rouxii*, a specific active glycerol transporter has been identified (Van Zyl *et al.*, 1990). In *S. cerevisiae*, the presence of a plasma membrane channel has been described through which the passage of glycerol is controlled in response to the osmotic potential of the medium (Luyten *et al.*, 1995). Glycerol accumulates in beer during fermentation, typically 1–2 g/l being formed. The osmotic stress response in *S. cerevisiae* is mediated by a specific sensing pathway termed the HOG (high osmolarity glycerol) signal transduction pathway. Two separate osmosensors located in the plasma membrane activate a common MAP (mitogen-activated protein) kinase signal transduction cascade. In response to the osmotic shock, a metabolic signal is passed through the kinase cascade, which culminates in the transcription of genes that encode enzymes including those responsible for glycerol synthesis (Maeda *et al.*, 1994). The HOG signal transduction pathway activates genes, which contain an element termed STRE in their promoter regions. The STRE element is present in many genes associated with responses to stresses other than osmotic shock. This general stress response is discussed in Section 12.9.

12.3.2 Sources of carbon

Yeasts, as a group, can assimilate a comparatively wide range of organic carbon compounds. An assessment of the range of such compounds that are utilized by individual strains is used as a diagnostic criterion in yeast taxonomy (Barnett *et al.*, 1990; Chapter 11). The most commonly used carbon sources are carbohydrates, including mono-, di- and trisaccharides, higher dextrans and starches. Some species can utilize pentoses, although not brewing yeast strains. Growth may be oxidative and/or fermentative depending on the strain and the cultural conditions. Less usual carbon sources are used by certain species such as methanol and both aliphatic and aromatic hydrocarbons.

Strains of *S. cerevisiae* utilize a limited repertoire of carbon sources for growth (Table 12.1). Differences in the patterns of utilization are strain-specific. Ale strains lack the ability to utilize the disaccharide, melibiose. Lager strains can grow on melibiose because they have α -D-galactosidase activity, which hydrolyzes it to galactose and glucose (Barnett, 1981). There are other differences between ale and lager strains. The latter utilize maltotriose more rapidly than ale strains (Stewart *et al.*, 1995) and lager strains are more efficient at assimilating galactose. Lager strains utilize mixtures of galactose and maltose simultaneously, whereas ale strains assimilate maltose preferentially (Crumplen *et al.*, 1993). The yeast, *S. cerevisiae* var. *diastaticus* can utilize dextrans, albeit with the chemically unrelated formation of styrene and 4-vinyl guaiacol which impart a phenolic medicinal taint to beer (Ryder *et al.*, 1978).

Many metabolic intermediates accumulate in the growth medium. These include pyruvate (4.146), acetaldehyde and several organic acids such as citric (4.153), malic and acetic. Some of these may be re-assimilated at a later stage in growth. The major products of fermentative growth are ethanol, glycerol, lactic acid and carbon dioxide. A proportion of the latter is fixed in a series of carboxylation reactions. Up to 5% of the carbon

Table 12.1 Utilization of carbon sources by *S. cerevisiae* under aerobic and anaerobic conditions

Carbon source	Aerobic	Anaerobic
D-Glucose	All strains	All strains
Cellobiose	—	—
Ethanol	Some strains	—
D-Galactose	Some strains	—
D-Glucitol	—	—
Glycerol	Some strains	—
Inulin	—	—
DL-Lactate	Some strains	—
Lactose	—	—
Maltose	Some strains	Some strains
D-Mannitol	Some strains	—
Melezitose	Some strains	Some strains
Melebiose	Some strains	Some strains
Methanol	—	—
Methyl- α -D-glucopyranoside	Some strains	Some strains
Raffinose	Some strains	Some strains
L-Sorbose	—	—
Starch	Some strains	Some strains
Succinic acid	Some strains	—
Sucrose	Some strains	Some strains
Trehalose	Some strains	Some strains
D-Xylose	—	—
Xylitol	—	—

requirement of yeast is provided by carbon dioxide fixation (Oura *et al.*, 1980). In the presence of oxygen, some strains can undergo a metabolic adaptation, termed the diauxic shift, and utilize ethanol, lactic acid and glycerol for oxidative growth.

12.3.3 Sources of nitrogen

Yeasts cannot assimilate gaseous nitrogen, however, simple inorganic sources such as ammonium salts may be readily utilized. A diverse range of organic sources of nitrogen can be assimilated (Soumalainen and Oura, 1971) including amino acids, peptides, amines, pyrimidines and purines. Many of these, for example, amines, are utilized as a source of nitrogen only in the presence of additional sources of carbon and energy. The ability, or inability, to use a specific organic nitrogen source can have taxonomic significance. *Saccharomyces* yeasts cannot utilize nitrate or nitrite but readily assimilate ammonium ions. In natural media, such as brewers' wort, ammonium ions, amino acids, peptides, purines and pyrimidines provide most of the nitrogen. These yeasts strains do not produce extracellular proteases and therefore, proteins are not utilized.

12.3.4 Sources of minerals

Sulphur may be assimilated from both inorganic and organic sources. The latter include the sulphur-containing amino acids, methionine (4.41) and cysteine (4.31). In addition, glutathione may be assimilated. The preferred inorganic source of sulphur is sulphate but sulphite and thiosulphate can also be utilized. *S. cerevisiae* can reduce elemental sulphur to thiol ions in the periplasm and thereafter these are assimilated (Rose, 1987). The requirement for phosphorus is satisfied by the assimilation of inorganic phosphate ions.

Elemental mineral ions are essential co-factors for numerous enzyme activities. Some have structural roles and others are necessary components of transport systems where they fulfil a charge-balancing role. The concentrations required for growth are small, typically less than $10\ \mu\text{M}$ (Jones and Greenfield, 1984). Essential mineral ions include B^+ , Ca^{2+} , Co^{2+} , Cu^{2+} , Fe^{3+} , K^+ , Mo^{2+} , Mn^{2+} , Mg^{2+} , Ni^{2+} and Zn^{2+} . Many ions, particularly those of heavy metals, are toxic in excess. Metal ions such as Na^+ , in high concentrations, exert a salt stress on yeast (Section 12.3.1). Precise requirements are strain specific and the combination and concentration of mineral ions available in the medium is important since synergistic and antagonistic interactions occur. Some metal ions may be tolerated by certain yeast strains but be growth inhibitory to others. For example, a commonly used test to differentiate between brewing and non-brewing 'wild' yeast strains is based on the ability of the latter to grow in the presence of relatively high concentrations of copper ions. A few ions, notably Mg^{2+} and K^+ , are required at higher concentrations, typically at the millimolar level.

Brewers' malt wort supplies all the mineral nutritional requirements of yeast, with the possible exception of zinc. Zinc ions can be chelated by wort amino acids, proteins and phytate and a proportion of these may be removed as insoluble precipitates during the copper boil (Daveloose, 1987). For this reason, zinc supplements are commonly added to wort in the fermenter.

12.3.5 Growth factors

Growth factors are a diverse group of organic compounds which individual yeast strains are unable to synthesize and which are essential for growth. Their presence in the

medium is obligatory. The group includes vitamins, some purines, pyrimidines, polyamines, nucleosides, nucleotides and certain lipids. Growth factors may be required as intermediates in certain essential metabolic pathways or have a structural role. More commonly, they are essential catalytic components of coenzymes as exemplified by vitamins. Concentrations required for growth are low, typically in the μM range. Vitamins, or derivatives of them, are involved in many fundamental biochemical processes, for example, biotin (carboxylation reactions), thiamine (oxo-acid decarboxylation reactions), nicotinic acid (redox reactions), pyridoxine (transaminations), *p*-aminobenzoic acid (one-carbon transfer) and pantothenic acid (acetylation reactions) (Fig. 4.29). The requirement for vitamins and other growth factors varies widely between individual strains. Individual strain requirements have taxonomic significance (Kreger-van Rij, 1984; Kurtzman and Fell, 1988).

With regard to brewing strains of *S. cerevisiae*, all require biotin and pantothenic acid. Many strains require inositol and thiamine. In general, lager strains have a greater requirement for growth factors compared to ale strains. Most brewers' worts contain adequate concentrations of growth factors for all yeast strains. In rare cases, a nutritional supplement, enriched in growth factors, is added to worts that are considered deficient. Such supplements, termed 'yeast foods', are partially purified extracts of yeast, occasionally with added vitamins. Under anaerobic conditions *Saccharomyces* strains become auxotrophic (have an absolute requirement for growth) for certain lipids. Thus, some sterols and unsaturated fatty acids, accumulated during prior aerobic growth or supplied in the medium, are essential components of membranes. In addition, unsaturated fatty acids appear to have roles as regulatory effector molecules. The syntheses of sterols and unsaturated fatty acids, *de novo*, require molecular oxygen (Section 12.7).

12.4 Nutrient uptake

Yeasts possess mechanisms to regulate the passage of nutrients from the external medium into the cell (Cartwright *et al.*, 1989). The plasma membrane forms the principal semi-permeable barrier through which all nutrients must pass. Cells have systems for sensing the nature and concentration of nutrients in the external medium. They have the ability to selectively assimilate individual compounds from complex mixtures in an ordered manner. Some nutrients can be transported into the cell against a concentration gradient. In addition to assimilating compounds from the external medium, some of the products of metabolism are excreted from the cell.

Cartwright and co-workers (1989) differentiate between *vectoral* and *scalar* metabolism. The latter is that portion of metabolism in which molecules are subject to chemical modification with no appreciable movement. The former is defined as that portion of metabolism that involves the controlled physical movement of molecules. Some vectoral metabolism is intracellular, for example, the controlled transport of metabolites between intracellular compartments. Although it is convenient to consider these two facets of metabolism as separate entities, they are, of course, regulated and coordinated processes.

A number of distinct mechanisms result in the passage of solutes across membranes. The simplest and slowest is free diffusion in which molecules traverse the membrane via the lipid components driven by a concentration gradient. Transport ceases when the solute concentration on each side of the membrane becomes equal. Other solute transport

processes require the intervention of specific membrane proteins, termed transporters or permeases. Facilitated diffusive transporters regulate the passage of solutes in the direction of a concentration gradient. As in the case of free diffusion, transport ceases when the concentration gradient ceases to exist.

The most prevalent type of transport system in yeast is that in which solutes passage is against a concentration gradient. The process is termed active transport since it requires metabolic energy. Movement of individual solutes is controlled by specific permeases, which may be inducible or constitutive. The energy is provided by the plasma membrane H^+ -ATPase (Serrano, 1989). The latter energizes the membrane by promoting the uni-directional movement of protons utilizing the energy released by the hydrolysis of ATP. The resultant proton motive force is a combination of the membrane potential and the proton gradient. Solute molecules usually travel across the membrane accompanied by protons, a mechanism termed proton symport transport. Occasionally, solute movement occurs against a reverse passage of protons, termed proton antiport transport.

Commonly, yeast cells possess multiple carriers for the same nutrient, or class of nutrients. Frequently, these carriers have different affinities for the same substrate. Thus, within the same strain there may be both high and low affinity transporters for given substrates. Often the latter is constitutive and the former inducible. Presumably, the high affinity inducible systems represent an evolutionary mechanism, which confers a selective advantage where mixed populations of yeast and other micro-organisms are competing for small amounts of essential nutrients.

Yeast membranes, including the plasma membrane and others enclosing intracellular organelles, possess channels which have been implicated in the transport of ions, water and some organic molecules, such as glycerol (Gustin *et al.*, 1986; Luyten *et al.*, 1995). The channels are proteinaceous in nature and are activated or deactivated by perturbations in membrane polarization. The predominant ion channel controls the efflux of K^+ . This phenomenon balances the influx of protons that accompany sugar uptake and is, therefore, necessary for intracellular charge homeostasis. Solute molecules may be transported enclosed in a vesicle, which arises from the plasma membrane. This process is termed pinocytosis. Its occurrence in yeast is disputed, although it may be implicated in the intracellular trafficking of macromolecules.

The transport systems described so far facilitate the entry of solutes without chemical modification. Group translocation systems mediate the uptake of solutes and in so doing modify chemical structures. In yeast, glucose uptake is coupled to phosphorylation. This process may be associated with the glucose transporters (Lagunas, 1993).

Before solutes pass through the plasma membrane and into the cell, they must negotiate the capsule, if present, the cell wall and the intervening periplasm. Yeast cell walls are freely permeable but their physical structure places an upper limit on the size of molecules that can pass through unimpeded. This feature is of benefit in that it allows retention of enzymes in the periplasm. The upper limit of cell wall porosity is in the region of 200–400 kDa (de Nobel *et al.*, 1991). The comparatively wide range reflects changes in cell wall porosity that occur during different phases in the yeast cell growth cycle.

12.4.1 Sugar uptake

The uptake of sugars by *Saccharomyces* strains have been subject to the closest scrutiny as befits their role in industrial fermentations (Andre, 1995; Horak, 1997). Although

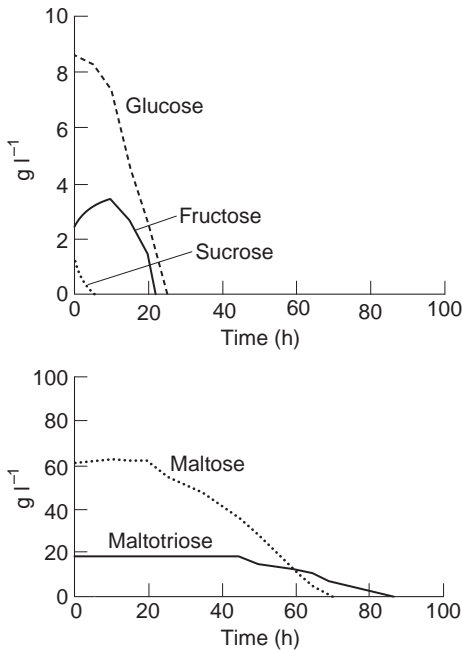

Fig. 12.4 Patterns of uptake of fermentable sugars from 10°Plato ale wort. The yeast was a top fermenting ale strain and the temperature was 18 °C (C. A. Boulton, unpublished data).

some sugars may enter the cell by free diffusion, uptake appears to be predominantly via active processes and is against a concentration gradient. Control of sugar uptake is complex and highly regulated. In industrial fermentations, using feedstocks containing complex mixtures of several sugars, uptake into the cell limits the overall rate of ethanol formation.

When presented with a mixture of assimilable sugars, yeasts have mechanisms for selecting first, those which are most readily utilized. In the case of brewers' wort, the utilization of sugars is an ordered process (Fig. 12.4). Sucrose is hydrolysed by an invertase that is secreted into the periplasm. This results in a transient increase in the concentrations of fructose and glucose. Fructose and glucose are assimilated simultaneously. The predominant sugar, maltose is then taken up. When the maltose concentration falls to an undetectable level maltotriose is assimilated. Longer chain sugars are not utilized by brewing yeasts.

A multiplicity of hexose uptake systems has been identified in various yeast strains (Kruckenberg, 1996; Ozcan and Johnston, 1999). Glucose is the preferred substrate but frequently other hexoses are also transported. In *S. cerevisiae*, at least 19 separate genes are responsible for the synthesis of hexose carriers. Two classes of hexose carrier are recognized, termed high and low affinity. The high affinity systems transport D-glucose, D-fructose and D-mannose and are of the facilitated diffusion variety. They have K_m values of approximately 1 mM. In the presence of relatively high glucose concentrations (> 0.1 M) activity is repressed (Does and Bisson, 1989). This phenomenon is part of a wider system of metabolic control, termed catabolite repression (Section 12.5.8). Activity of the high affinity carriers is associated with phosphorylation of the substrate via the glycolytic hexokinases and a glucokinase. Whether, or not, the phosphorylation involves interactions between kinases and the glucose carrier remains to be elucidated (Lagunas, 1993).

The low affinity hexose carriers are constitutive and have K_m values in the region of 20 mM. Their existence has been disputed since it has been claimed that low affinity glucose uptake could simply reflect passive diffusion. However, this suggestion has been refuted on the basis that uptake rates are 2–3 times higher than would be predicted for passive diffusion (Gamo *et al.*, 1995). The reason(s) for the multiplicity of hexose carriers is not clear. Detailed genetic analysis is needed to determine under what conditions each is active. It has been demonstrated that some of the carriers are subject to nitrogen catabolite inactivation (Busteria and Lagunas, 1986; Section 12.8). This process occurs following the exhaustion from the medium of certain nitrogen sources and leads to inactivation of hexose and other sugar uptake systems via proteolysis of the carriers. Probably other global metabolic control mechanisms, such as the availability of oxygen and other nutrients, will also influence the activity of individual hexose carriers.

Although the glucose transporters show activity towards other hexoses, *S. cerevisiae* also possesses a specific transport system for galactose. In common with the glucose uptake system, both constitutive low affinity and inducible high affinity galactose transporters exist. There are specific uptake systems for pentoses, in those yeast strains capable of utilizing them. In general, the activity of these is repressed by glucose.

Sucrose assimilation is dependent on the production of invertase. Synthesis of this enzyme is dependent on the presence of a number of SUC genes (SUC1–SUC5 and SUC7). Yeast cells produce an intracellular constitutive invertase, whose function is unknown. A second invertase is secreted into the periplasm and this is responsible for the assimilation of extracellular sucrose. The enzyme is also active towards raffinose. The fructose and glucose produced by the hydrolysis of sucrose are both transported via the hexose carrier system. The periplasmic invertase is subject to glucose repression although, surprisingly, for maximum transcription of SUC2 to occur a low concentration (0.1%) of glucose is required (Ozcan *et al.*, 1997).

Specific disaccharide carriers mediate the uptake of maltose (4.4) and trehalose (α -D-glucopyranosyl (1, 1)- α -D-glucopyranose). A constitutive low affinity transport system and a high affinity proton symport carrier accommodate trehalose uptake. The latter is subject to glucose repression. Derepressed yeast cells have high levels of intracellular trehalose. This suggests that under these conditions trehalose accumulation is against a concentration gradient. Probably the cell does this since there is evidence that trehalose 6-phosphate is involved in the control of glycolysis (Thevelein and Hohmann, 1995).

Maltose is the most abundant sugar in wort. Its uptake and utilization is controlled by a complex series of MAL genes. These occur at five unlinked homologous loci, not restricted to a single chromosome. Each locus consists of three genes, which encode for a maltose carrier, maltase and a post-transcriptional regulator of the carrier and maltase genes. Maltose utilization is repressed by glucose and requires the maltose for induction (Busteria and Lagunas, 1986). Maltose utilization is subject to nitrogen catabolite inactivation. Thus, under conditions of nitrogen exhaustion or in the presence of glucose, the maltose permease is irreversibly inactivated via the action of a protease. Maltose uptake is an energy-requiring proton symport process. Efflux of K^+ ensures electrochemical neutrality. The uptake system is of the high affinity variety. In brewing strains of *S. cerevisiae*, a second low affinity system has been identified (Crumplen *et al.*, 1996). Transport of maltotriose in *S. cerevisiae* is accomplished by a constitutive facilitated diffusion carrier. It has been suggested that the permease may be absent in some ale strains thus accounting for the observations that some of the latter are not able to utilize maltotriose (Stewart *et al.*, 1995).

12.4.2 Uptake of nitrogenous nutrients

Yeasts possess transport systems for mediating the uptake of both inorganic and organic nitrogen sources. In wort, yeast is presented with a complex mixture of nitrogen sources. As is the case with the utilization of carbon sources, uptake of nitrogenous nutrients is an ordered process. Thus, the presence in the medium of readily assimilable nitrogen sources represses the synthesis of the uptake systems and catabolic enzymes of other less readily utilized sources of this nutrient. This is termed nitrogen catabolite repression (Wiame *et al.*, 1985).

All yeasts can utilize ammonium ions and indeed this nutrient is usually utilized in preference to organic sources of nitrogen. However, in brewing yeast, during fermentation, several amino acids are utilized before ammonium ions. In *S. cerevisiae* high and low affinity carriers control the uptake of ammonium ions. The high affinity carrier is an active transport system and requires the presence of an oxidizable substrate for activity. *S. cerevisiae* does not utilize nitrate or nitrite. Individual yeast strains can assimilate a wide range of organic sources of nitrogen. Most strains can utilize urea and in *S. cerevisiae* high and low affinity urea transporters occur. A number of transporters occur in yeast specific for one or small groups of amino acids. In addition, there is a general amino acid permease (GAP) with broad specificity. Some of the transporters, including GAP, are repressed by ammonium ions, asparagine and glutamine (Grenson, 1992). In *S. cerevisiae*, 12 constitutive and four nitrogen-repressible amino acid carriers have been identified (Horak, 1986). The transporters can be of the high or low affinity type, uptake is active and involves proton symport.

Maximum activity of GAP occurs only under conditions of nitrogen starvation. In this regard, GAP functions as a nitrogen scavenger. Regulation of the other carriers is complex and dependent on the spectrum and concentrations of amino acids present in the medium. The presence of multiple carriers for amino acids affords the yeast an opportunity to order uptake in response to need. Based upon chemostat studies with *S. cerevisiae* growing under conditions of nitrogen limitation, it has been suggested (Olivera *et al.*, 1993) that the specific permeases are involved in the uptake of amino acids destined for use in anabolic pathways. Conversely, those permeases subject to nitrogen catabolite repression, including GAP, mediate the uptake of amino acids used in catabolic pathways.

In brewing yeasts growing on wort, the uptake of amino acids is an ordered process. Pierce (1987) divided amino acids into four classes, based on their order of assimilation from wort during fermentation (Table 12.2). Surprisingly, in view of its role in nitrogen catabolite repression, ammonia is not a member of the first group, although asparagine and glutamine are. The amino acids in classes A and B are required for anabolic metabolism, principally protein synthesis. They are taken up by those permeases that are not subject to nitrogen catabolite repression. Conversely, those in Class C are only taken up when the Class A amino acids have disappeared and nitrogen catabolite repression is relieved. Proline is the sole member of class D. This imino acid is not utilized during brewery fermentation since its oxidation requires a mitochondrial oxidase, which is repressed during fermentation (Wang and Brandriss, 1987).

Short homopeptides may be taken up by yeast although not as readily as the free amino acids (Ingledeew and Patterson, 1999). Ammonia inhibits the uptake of dipeptides. Peptides containing no more than five amino acid residues may be transported into the cell. The carrier in *S. cerevisiae* is reportedly of broad specificity, active and capable of transporting di- and tripeptides (Marder *et al.*, 1977). *S. cerevisiae* strains are not capable of transporting oligopeptides and, since they do not produce exogenous proteases, are not able to utilize these nitrogen sources.

Table 12.2 Amino acid classification based on the order of assimilation from wort during fermentation (Pierce, 1987). Amino acids are assimilated in the order A, B, C, D

Class A	Class B	Class C	Class D
Arginine	Histidine	Alanine	Proline
Asparagine	Isoleucine	Ammonia	
Aspartate	Leucine	Glycine	
Glutamate	Methionine	Phenylalanine	
Glutamine	Valine	Tryptophan	
Lysine		Tyrosine	
Serine			
Threonine			

Uptake of purines and pyrimidines is accommodated by both active proton symport systems and by facilitated diffusion carriers. The active systems reportedly mediate the uptake of adenine, adenosine, cytosine, guanine and hypoxanthine. Transport of uracil and uridine is apparently by facilitated diffusion (Cartwright *et al.*, 1989).

12.4.3 Lipid uptake

Saccharomyces cerevisiae utilizes lipids such as fatty acids and sterols. These may be used for direct incorporation into cellular structures, as sources of metabolic intermediates for both catabolic and anabolic pathways or to fulfil roles in cellular signalling systems. At high concentrations, fatty acids are taken up by simple diffusion, a process aided by the lipophilic nature of the plasma membrane (van der Rest *et al.*, 1995). In *S. cerevisiae*, the presence of a medium chain length fatty acid transporter has been inferred (Faergeman *et al.*, 1997). In anaerobic brewery fermentations, brewing yeasts are auxotrophic for unsaturated fatty acids. These compounds must be synthesized during the aerobic phase of fermentation. Some of this requirement may be satisfied by direct uptake from wort.

Yeast can assimilate exogenous sterols but only under anaerobic conditions when *de novo* synthesis is precluded. This phenomenon is termed aerobic sterol exclusion. Sterol uptake requires expression of the SUT1 and SUT2 genes (Bourdot and Karst, 1995). These are hypoxic genes, expressed only under anaerobic conditions. It is assumed that the product of their expression inhibits the transcription of the genes encoding the sterol transporter.

12.4.4 Ion uptake

Uptake of metal ions by yeast is a biphasic process. Firstly, ions are concentrated by attachment to the cell surface, a passive process termed biosorption. Suggested mechanisms for attachment to the cell wall include complexation, ion exchange, adsorption and precipitation (Blackwell *et al.*, 1995). The process is independent of temperature, does not require metabolic energy or indeed viability. It has been suggested that it may serve as a protective strategy for the removal of potentially toxic ions. Secondly, ions are transported across the plasma membrane and into the cell by bioaccumulation. This is an active process involving proton symport and K^+ efflux. Once in the cell, metal ions are commonly compartmentalized in the vacuolar system. Metal ion uptake is tightly regulated since individual ions may be essential or toxic at low and high concentration, respectively. Different yeast species possess metal ion carriers of

both broad and narrow specificity. Metal ion transport is a dynamic process and synergistic and antagonistic effects are possible depending on the spectrum of ions present. Metal ion uptake and efflux occur reflecting the need of the cell to maintain an internal ionic balance and still supply ions where needed for proper enzyme function (Jones and Gadd, 1990).

S. cerevisiae possesses a metal ion carrier with broad specificity, capable of transporting the divalent ions of calcium, cobalt, nickel, manganese, magnesium, strontium and zinc. The carrier has the highest affinity for Mg^{2+} and uptake of this ion occurs simultaneously with phosphate. Uptake of Co^{2+} , Mn^{2+} , Fe^{2+} and Zn^{2+} ions in *S. cerevisiae* is mediated by distinct high and low affinity transporters. Activity of the individual carriers is dependent upon the availability of the ions and typically, the high affinity permeases have scavenging roles. Uptake of manganese is competitively inhibited by magnesium ions. The iron transporter also mediates the uptake of cadmium, cobalt and nickel.

Zinc uptake is of particular relevance to brewing in that malt worts may be deficient in this ion (Daveloose, 1987; Chapter 4). It plays an essential role in the function of many enzymes, including alcohol dehydrogenase. *S. cerevisiae* maintains zinc homeostasis by the operation of carriers that mediate both uptake and efflux. Copper is an essential nutrient at low concentration but can be toxic at higher levels. The ability of certain strains of 'wild' yeast to grow in the presence of copper at a concentration that brewing strains of *S. cerevisiae* cannot tolerate is of diagnostic importance. Copper uptake is mediated by a high affinity carrier expressed by the CTR 1 gene. The transporter may also be responsible for the uptake of ferrous ions. Copper homeostasis is achieved by regulated intracellular sequestration in the form of a metallothionin protein. In addition, transporters are present that function as mediators of copper ion efflux.

Calcium ions have important roles in metabolic signalling systems. They are implicated in the control of the mating response (not applicable to brewing yeast), modulation of cellular growth and progress through the cell cycle. In consequence, intracellular calcium ion concentration is highly regulated (Youatt, 1993). An active proton antiport permease regulates calcium transport across both the plasma and vacuolar membranes. Calcium ions are sequestered in the cell by specific binding proteins such as calmodulin.

Transport of potassium ions is used by yeast cells to maintain charge homeostasis. Frequently, efflux of potassium ions is used by yeast in conjunction with proton symport permeases, to maintain electrochemical neutrality. It is the most common intracellular ion in the yeast cytosol. The high intracellular concentration is maintained by several parallel transport systems. These include uptake via both active systems and plasma membrane pores. In *S. cerevisiae*, the active system is a proton antiporter.

Phosphate uptake is dependent on the presence of a fermentable substrate and both high and low affinity transporters occur in *S. cerevisiae*. Under conditions of phosphate limitation, the PHO5 gene is induced. This encodes for a secreted acid phosphatase and this is involved in phosphate scavenging. In some yeasts, for example *Zygosaccharomyces bailii*, active carriers exist for the uptake of sulphate and sulphite. In brewing yeast, uptake of the latter is apparently via simple diffusion of sulphur dioxide, whereas several carriers mediate the uptake of sulphate. The presence of sulphite inhibits the utilization of sulphate.

Movement of hydrogen ions into and out of the cell is of paramount importance in controlling the transport of other charged species and maintenance of intracellular pH. The trans-membrane proton gradient and proton-motive force is generated by

H⁺-ATPase. The importance of the latter is indicated by the fact that it is the most abundant membrane protein (Serrano, 1989).

12.4.5 Transport of the products of fermentation

During fermentation, the transformation of wort into beer is accompanied by a decrease in pH. Much of this decrease is a result of the proton antiport component of other uptake systems. Acidification of beer is also contributed to by the formation of carbonic acid derived from the carbon dioxide produced during fermentation. In addition, several organic acids, notably, lactic, citric, pyruvic, malic, acetic, formic, succinic and butyric acids are excreted from fermenting yeast cells. In the latter stages of fermentation, some of these compounds may be re-assimilated. Transport may be via simple diffusion or active uptake systems involving proton symport.

Many products of yeast metabolism contribute to beer flavour (Chapter 23). These include ethanol, higher alcohols, esters, aldehydes and vicinal diketones. It follows that these metabolic by-products must be transported out of or released from the cell during fermentation. This subject has received little attention; probably non-concentrative diffusion is the mechanism used.

12.5 Sugar metabolism

The catabolism of sugars provides yeast with energy and carbon skeletons for anabolic pathways. This is an essential activity and in consequence, a large proportion of total metabolism is devoted to it. Several distinct pathways are involved. The flux of carbon through individual pathways is influenced by yeast genotype and its phenotypic expression as brought about by the conditions to which they are exposed.

12.5.1 Glycolysis

Glycolysis, or the Embden-Myerhof-Parnas pathway, is the major sugar catabolic pathway in yeast. It operates under both aerobic and anaerobic conditions and is the route by which approximately 70% of exogenous hexose sugars are assimilated. The importance of this pathway is reflected in the fact that glycolytic enzymes comprise 30–65% of the total soluble protein pool in *S. cerevisiae*. (Fraenkel, 1982). The pathway catalyses the conversion of one molecule of glucose into two molecules of pyruvate (Fig. 12.5). The initial phosphorylation reaction, in which ATP is the phosphate donor, may be catalysed by one of three enzymes. Hexokinases 1 and 2 show activity towards both glucose and fructose and glucokinase with glucose, alone. All show activity towards mannose. All of the glycolytic reactions are reversible with the exceptions of the initial phosphorylation of glucose, the phosphorylation of fructose-6-phosphate to yield fructose 1,6 biphosphate and the dephosphorylation of phospho-*enol*-pyruvate to form pyruvate. Several of the steps are catalysed by multiple enzymes, as indicated. Glycolysis can operate in the reverse (gluconeogenic) direction. In this case, three additional enzymes, phospho-*enol*-pyruvate carboxykinase, fructose 1,6-bisphosphatase and glucose 6-phosphate phosphatase catalyse the contra-flow of carbon past the irreversible steps of glycolysis. Other sugars feed into the glycolytic pathway as shown in Fig. 12.6. Like glucose, the utilization of these other sugars also involves reactions in which ATP is consumed and phosphorylated intermediates are formed. Some of the reactions use the

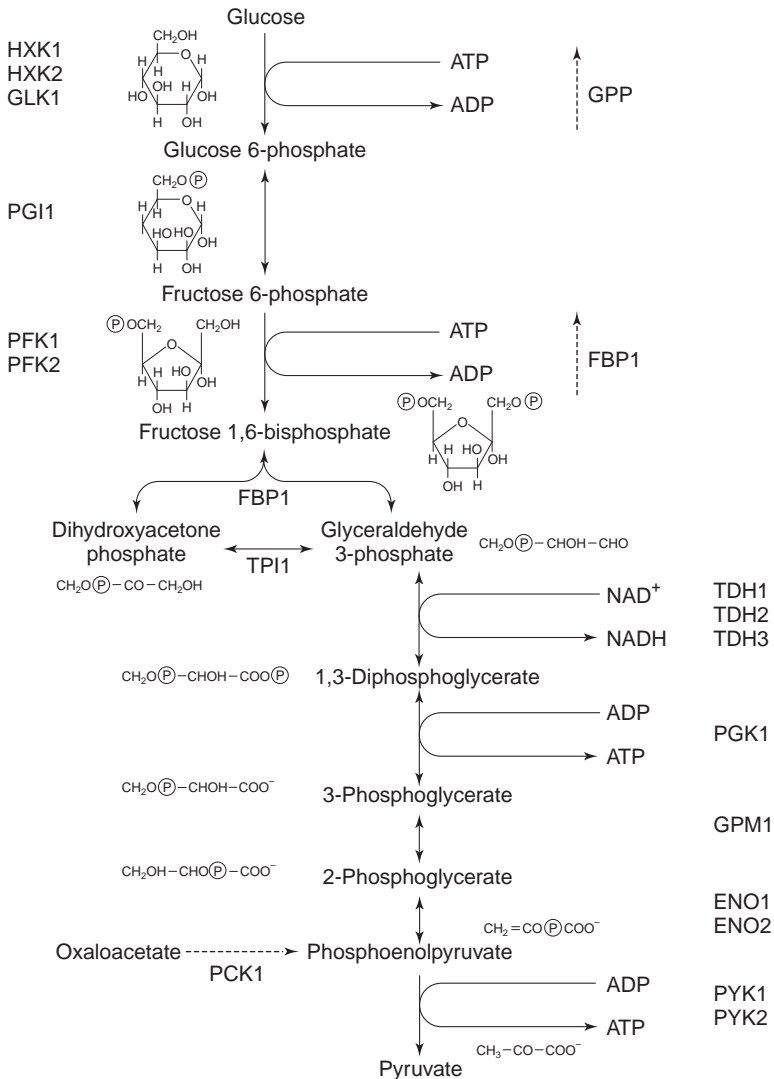

Fig. 12.5 The main glycolytic pathway. The genes and enzymes responsible for each step are: HXK1, HXK2, hexokinases; GLK1, glucokinase; PGI1, phosphoglucose isomerase; PFK1, PFK2, phosphofructokinase; FBP1, fructose 1,6-bisphosphatase; FBA1, fructose 1,6-bisphosphate aldolase; TPI1, triose phosphate isomerase; TDH1, TDH2, TDH3, glyceraldehyde 3-phosphate dehydrogenase; PGK1, phosphoglycerate kinase; GPM1, glycerophosphate mutase; ENO1, ENO2', enolase; PYK1, PYK2, pyruvate kinase. Three gluconeogenic enzymes are also shown: GPP, glucose 6-phosphate phosphatase; FBP1, fructose 1,6-bisphosphatase; PCK1, phosphoenolpyruvate carboxykinase.

coenzyme, uridine triphosphate (UTP), which gives rise to a carrier of sugar molecules (e.g. UDPG; 4.55).

Glycolysis generates reducing power in the form of NADH. This is re-oxidized in redox balancing reactions (Section 12.2). During the conversion of glucose to fructose 1,6-bisphosphate, two molecules of ATP are consumed. In the later stages of glycolysis, four ATP molecules are generated in the reactions catalysed by phosphoglycerokinase

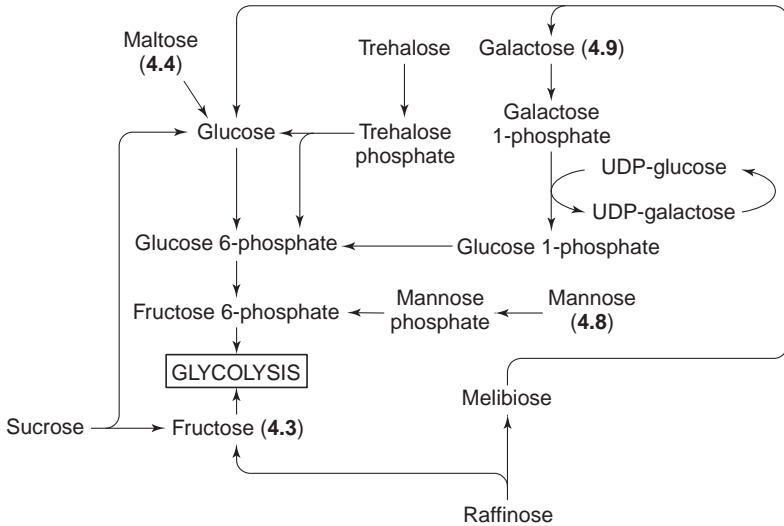

Fig. 12.6 The mode of entry of various sugars into the glycolytic pathway. The numbers in parentheses indicate where the molecular structures may be found.

and pyruvate kinase. Therefore, for every molecule of glucose catabolized there is a net gain of two molecules of ATP. This phenomenon is termed substrate level phosphorylation. It is the predominant mechanism used by yeast to generate energy-rich compounds under fermentative conditions. Glycolysis is active in yeast under all conditions and the component enzymes are constitutive. During growth on sugars, the direction of carbon flow is from glucose to pyruvate. During growth on oxidative carbon sources such as ethanol, the glycolytic pathway is reversed and is used to generate intermediates for anabolism. In this respect, glycolysis/gluconeogenesis is an amphibolic pathway, which serves both anabolic and catabolic roles. Reverse glycolysis is part of gluconeogenic sugar generating metabolism (Section 12.5.6).

Carbon flux through glycolysis is a regulated process and controls are exerted on both gene expression and enzyme activity. Transport of sugars into the cell, phosphorylation of glucose and regulation of the activities of phosphofruktokinase and pyruvate kinase by metabolic effectors have all been implicated. Possibly uptake of sugars is the rate-determining step in glycolysis since the maximum rates of transport are close to the maximum observed rates of glycolytic flux. The intracellular concentration of glucose is always lower than that in the external medium. Nitrogen starvation, which brings about a progressive decline in rates of glycolytic flux, affects rates of sugar transport but not the activities of the glycolytic enzymes.

Modulation of the activity of hexokinases by trehalose 6-phosphate may be of regulatory significance. Trehalose 6-phosphate is a strong competitive inhibitor of hexokinase and this may be used to control the entry of glucose into glycolysis. Alternatively, or possibly as well as, the synthesis of trehalose (Section 12.5.7) may be used as a mechanism for controlling levels of phosphate. During exponential growth of *S. cerevisiae* on glucose, the maximum glycolytic flux is within the range 200–300 $\mu\text{mol.hexose}/\text{min./g}$ dry weight of yeast. Most of the glycolytic enzymes, under optimal conditions, are capable of greater activity than this, indicating that they are probably not rate-determining. Phosphofruktokinase alone has a maximum activity close to the measured maximum rate of glycolytic flux, suggesting a possible regulatory role.

Further evidence for this regulatory role is the fact that the activity of this enzyme is modulated by several effectors. Phosphofructokinase has an obligate requirement for Mg^{2+} , NH_4^+ and K^+ . Binding of fructose 6-phosphate is positively co-operative. ATP inhibits activity and AMP is stimulatory.

The concerted effect of these metabolites on the activity of phosphofructokinase possibly explains why in yeast, under some conditions, flux through glycolysis becomes oscillatory. The explanation for this also supports the rate-determining role of phosphofructokinase in glycolysis. The oscillatory behaviour can be induced in cell-free extracts by the addition of fructose 6-phosphate but not fructose 1, 6-bisphosphate, indicating that phosphofructokinase is the site of the effect. Fructose 6-phosphate activates phosphofructokinase, which results in a decline in the concentration of ATP and concomitant increase in levels of ADP and AMP. In turn, this activates phosphoglycerate kinase and pyruvate kinase further down the glycolytic pathway. In addition, fructose 1, 6-bisphosphate activates pyruvate kinase. This removes ADP and AMP and increases the concentration of ATP via substrate level phosphorylation. High levels of ATP and reduced fructose 6-phosphate now combine to reduce the activity of phosphofructokinase. In consequence, high ATP concentration inhibits the glycolytic kinases, fructose 6-phosphate accumulates and the cycle is triggered again.

Modulation of the activity of phosphofructokinase by substrates and products of the reaction undoubtedly has significance. However, in terms of overall control of glycolytic rates, the effect of another metabolite, fructose 2, 6-bisphosphate appears to be of greater importance. Fructose 2, 6-bisphosphate (F2,6bP) is produced from fructose 6-phosphate and ATP by the action of 6-phosphofructo-2-kinase (6PF2K). In yeast, a second enzyme, fructose 2, 6-bisphosphatase (2, 6bPase) degrades F2, 6bP to fructose 6-phosphate and phosphate. Fructose 6-phosphate is a very potent activator of 6-phosphofructo-1-kinase, the major glycolytic enzyme. Furthermore, F2, 6bP inhibits the activity of the gluconeogenic enzyme, fructose 1, 6-bisphosphatase.

The activities of 6PF2K and 2,6bPase are regulated by reversible phosphorylation. In the phosphorylated form, 6PF2K is activated and 2,6bPase is inhibited. Activity of the kinase responsible for the phosphorylation is itself controlled by cAMP in a glucose-mediated regulatory cascade similar to that shown in Fig. 12.14 on page 437. In *S. cerevisiae*, a very close correlation exists between the intracellular concentration of F2,6bP and the production of ethanol. This suggests that F2,6bP is of predominant importance in controlling glycolytic flux.

12.5.2 Hexose monophosphate (pentose phosphate) pathway

The hexose monophosphate pathway is an alternative route to glycolysis for sugar metabolism (Fig. 12.7). The pathway is often referred to as a shunt since it diverts a proportion of glucose from the main glycolytic path and returns metabolites at the level of triose phosphate and fructose 6-phosphate. The first part of the pathway is irreversible and catalyses the oxidation of glucose 6-phosphate into a pentose phosphate. The oxidation generates reducing power in the form of $NADPH+H^+$. This is utilized in anabolic reactions, which have a specific requirement for this pyridine nucleotide.

The second part of the pathway involves a series of mostly reversible interconversions of pentose phosphates, hexose phosphates and triose phosphates. This provides a route for the assimilation of pentoses, in those yeast strains (not *S. cerevisiae*) capable of utilizing them. In addition, it provides precursors for the biosynthesis of some vitamins, purine and

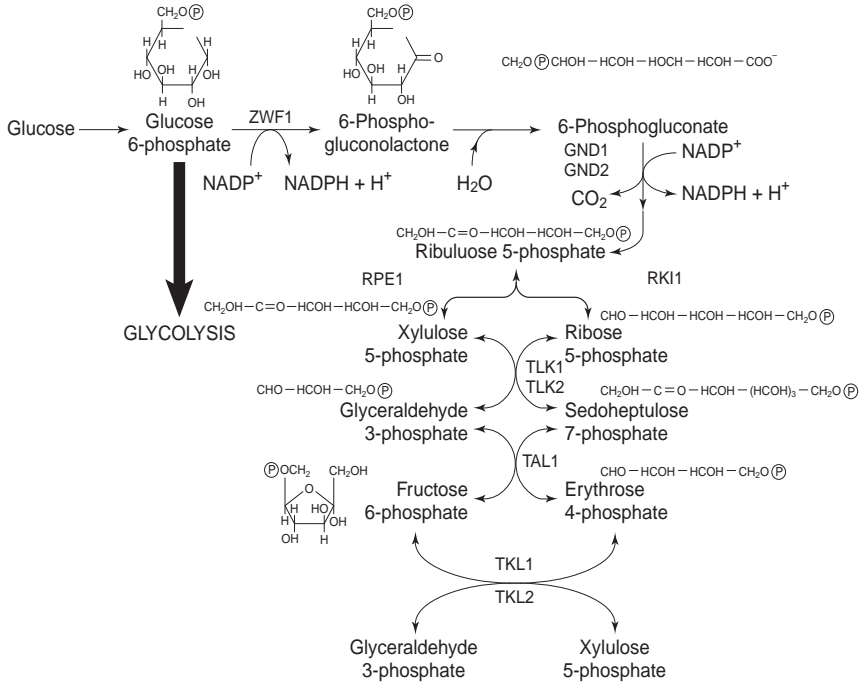

Fig. 12.7 The hexose monophosphate pathway (pentose phosphate pathway). The genes and enzymes responsible for each step are: ZWF1, glucose 6-phosphate dehydrogenase; GND1, GND2, 6-phosphogluconate dehydrogenase; RPE1, D-ribulose 5-phosphate; RKI1, D-ribose 5-phosphate ketoisomerase; TKL1, TKL2, transketolase; TAL1, transaldolase.

pyrimidine nucleotides as well as the aromatic amino acids, phenylalanine, tryptophan and tyrosine.

The proportion of carbon flow that is diverted through the hexose monophosphate shunt is dependent on the cellular requirements for anabolism. Since yeast growth during brewery fermentations is modest, it seems likely that this proportion is commensurately small. For yeast growing under fully oxidative conditions, where growth yields are relatively higher, the proportion of carbon diverted through the hexose monophosphate shunt will be higher. In addition, where the growth medium is relatively simple, anabolic requirements are increased, as is the need for NADPH. Bruinenberg *et al.* (1983) estimated that under aerobic conditions 2–3% of carbon flow had to pass through the hexose monophosphate shunt to fulfil the anabolic requirements of yeast cells growing on glucose.

12.5.3 Tricarboxylic acid cycle

In oxidative metabolism, some of the pyruvate derived from glycolysis is oxidized to acetyl Coenzyme A (acetyl-CoA), a reaction catalysed by the pyruvate dehydrogenase complex. The acetyl units are then completely oxidized to two molecules of carbon dioxide in a series of reactions variously termed the citric acid cycle, tricarboxylic acid cycle (TCA) or Krebs cycle. Coenzyme A, serves as a carrier of acyl groups in many enzymatic reactions. It contains the growth factor pantothenic acid. The latter possesses a terminal thiol group, which is capable of forming thioesters with acyl groups. Pyruvate

dehydrogenase is a multi-enzyme complex, which is located in the mitochondrial matrix. It shares structural and functional similarities with glycine dehydrogenase, α -ketoglutarate dehydrogenase and branched-chain α -ketoacid dehydrogenase. All contain a common component, lipoamide dehydrogenase, which contains the reducible prosthetic group, flavin adenine dinucleotide (FAD).

The conversion of pyruvate to acetyl-CoA is an oxidative decarboxylation reaction. Following the initial release of CO_2 , the coenzyme, thiamine pyrophosphate (TPP, vitamin B_1) acts as a carrier of the resultant α -hydroxyethyl group. The latter is reduced and the bound acetyl group is transferred to another coenzyme, lipoic acid, in a reaction catalysed by lipoate acetyl transferase. The acetyl group is then transferred to coenzyme A and acetyl CoA is released. The reduced lipoic acid coenzyme is re-oxidized by lipoamide dehydrogenase. Finally, the reduced FAD prosthetic group of the latter enzyme is re-oxidized by NAD^+ and $\text{NADH} + \text{H}^+$ is liberated.

Acetyl-CoA enters the tricarboxylic acid cycle (TCA) in a reaction in which it condenses with oxaloacetate to form citrate (Fig. 12.8). For each turn of the cycle, two

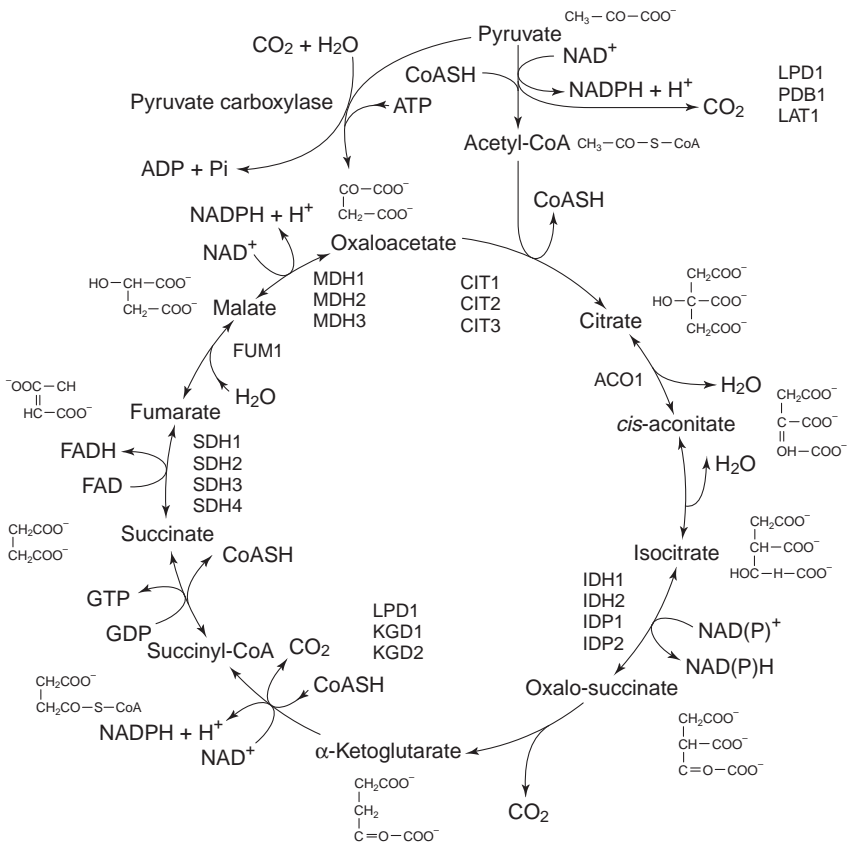

Fig. 12.8 The tricarboxylic acid (TCA) cycle. The genes and enzymes responsible for each step are: LPD1, PDA1, PDB1, LAT1, component parts of pyruvate dehydrogenase complex; CIT1, CIT2, CIT3, citrate synthase; ACO1, aconitase; IDH1, IDH2, NAD-dependent isocitrate dehydrogenase; IDP1, IDP2, NADP-dependent isocitrate dehydrogenase; KGD1, KGD2, LPD1, component enzymes of α -ketoglutarate dehydrogenase (LPD1 lipoamide dehydrogenase); SDH1, SDH2, SDH3, SDH4, succinate dehydrogenase; FUM1, fumarase; MDH1, MDH2, MDH3, malate dehydrogenase.

molecules of CO_2 are liberated and reducing power is generated in the form of $\text{NADH}+\text{H}^+$ and FADH . A proportion of the reduced coenzymes is re-oxidized by the electron transport chain. The passage of electrons/ H^+ down the chain to oxygen, where it is oxidized to water, is a process that generates large quantities of ATP (Section 12.5.4). Several of the steps in the TCA cycle are catalysed by isozymes, multiple forms of the same enzyme, each encoded by a distinct gene. This apparent redundancy is explainable in that, like glycolysis, the TCA cycle is an amphibolic pathway that serves both anabolic and catabolic functions. Typically, individual isozymes fulfil different roles in cellular metabolism. Thus, some function in the oxidative cycle and generate reducing power for the electron transport chain. Others are part of another pathway, the glyoxylate cycle, which has a role in gluconeogenesis (Section 12.5.6).

Some TCA cycle isozymes have biosynthetic roles and provide precursors used for the formation of amino acids such as aspartate and glutamate. Other TCA cycle enzymes contribute to anaplerotic pathways. These are metabolic sequences which literally have a 'filling up' function. Thus, some of the carbon flux through the TCA cycle is utilized in biosynthetic reactions. For the oxidative cycle to continue it is essential to replenish these intermediates via alternative routes. Commonly, the different isozymes occupy distinct intracellular compartments or organelles. These organelles have particular metabolic pathways associated with them and these underpin the functions of the organelles. The oxidative TCA cycle is located within mitochondria and glyoxylate cycle enzymes are found within peroxisomes. Enzymes associated with biosynthesis and anaplerosis are usually located in the cytosol.

Citrate synthase is the rate-limiting step in the TCA cycle. The enzyme, encoded by the CIT1 gene, is mitochondrial and part of the oxidative TCA cycle. The CIT2 gene product is peroxisomal and part of the glyoxylate cycle. The CIT1 citrate synthase is subject to glucose repression. This phenomenon is exhibited by many of the other mitochondrial isozymes, for example, aconitase and malate dehydrogenase (MDH1 and MDH2). In addition, MDH2 malate dehydrogenase is subject to catabolite inactivation, whereas, α -ketoglutarate dehydrogenase activity is regulated by catabolite repression.

Four isozymes of isocitrate dehydrogenase are synthesized by yeast, two mitochondrial and two cytosolic. One of each pair is specific for NAD^+ whereas, the other two are specific for NADP^+ . Only the NAD^+ -linked enzymes are active in the oxidative TCA cycle. The NADP^+ -linked enzymes probably have anaplerotic roles, as does the MDH2 malate dehydrogenase. The peroxisomal MDH3 enzyme appears to be involved in the oxidation of NADH , which is produced from β -oxidation of fatty acids (Section 12.7.1).

The supply of oxaloacetate for the oxidative TCA cycle (Fig. 12.8) is ensured primarily by the action of the anaplerotic enzyme, pyruvate carboxylase. This catalyses the condensation of pyruvate and CO_2 to form oxaloacetate. The enzyme contains biotin as a prosthetic group. Biotin serves as a carrier of carboxyl groups. Energy is provided by the breakdown of a molecule of ATP. Pyruvate carboxylase is inhibited by aspartate and allosterically activated by acetyl-CoA and ATP. The inhibition is an end-product feedback control mechanism since aspartate is derived from the transamination of oxaloacetate. Stimulation by acetyl-CoA and ATP ensures that there is always a sufficient supply of oxaloacetate to maintain an adequate supply of substrates for citrate synthase. Transamination reactions between glutamate and pyruvate to yield alanine and oxaloacetate may also be of anaplerotic significance.

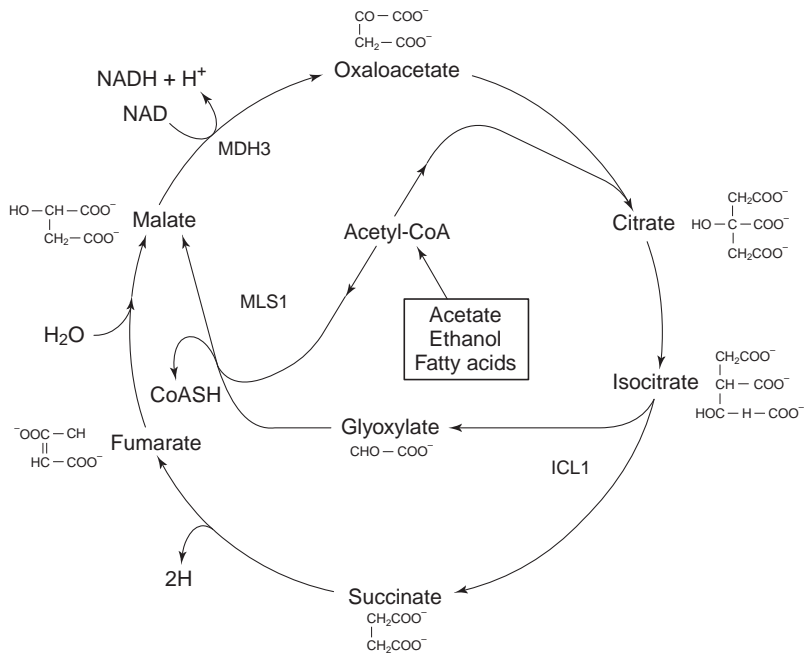
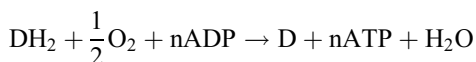

Fig. 12.9 The glyoxylate cycle. The genes and enzymes are: ICL1, isocitrate lyase; MLS1, malate synthase; MDH3, malate dehydrogenase (cytosolic). Other stages are catalysed by enzymes of the tricarboxylic acid cycle.

12.5.4 Electron transport and oxidative phosphorylation

In the terminal stage of the oxidative catabolism of sugars, the reduced redox coenzymes, $\text{NADH} + \text{H}^+$ and FADH (reduced FAD ; **4.94**), arising from the TCA cycle and glycolysis, are re-oxidized. The process is mediated by a series of redox carriers and it culminates in the reduction of molecular oxygen to water. Together, the redox carriers constitute the respiratory or electron transport chain (Fig. 12.9). Consecutive components of the electron transport chain have progressively more positive standard redox potentials, which facilitates the ordered transfer of electrons. Transfer of electrons down the transport chain generates energy, a proportion of which is retained in the form of the high-energy bonds of ATP. The process of energy transduction is termed oxidative phosphorylation. It can be summarised in the following equation:



DH_2 is a hydrogen donor. The value of n is a variable and is dependent on the tightness of coupling between respiration and phosphorylation and the nature of the donor. The efficiency of phosphorylation is commonly expressed as the P:O ratio, which is the number of ATP molecules generated per oxygen atom utilized.

The redox carriers are a diverse group of compounds that share the common property of having a reversibly reducible component. Cytochromes are haemoproteins in which the prosthetic group, haem, is a tetracyclic pyrrole, containing an atom of iron, which can be reversibly reduced from the ferric to the ferrous form. Ubiquinone (Coenzyme Q) is a hydrophobic quinone, which can be reversibly reduced to the quinol form. Iron sulphur proteins also undergo transitions between the ferrous and ferric states. Flavoproteins

contain prosthetic groups flavin mononucleotide (FMN) or flavin adenine dinucleotide (FAD). Both contain a reversibly reducible isoalloxazine group within the riboflavin moiety.

The electron transport chain consists of five complexes, which are located within the inner mitochondrial membrane (Fig. 12.9). The first complex, NADH-CoQ reductase accepts electrons from NADH, generated by the mitochondrial TCA cycle. The electrons are passed on to a pool of ubiquinone causing the latter to be reduced to ubiquinol. The ubiquinone pool also accepts electrons from the second complex, succinate dehydrogenase, located on the inner surface of the inner mitochondrial membrane. In yeast, this dehydrogenase also shows activity towards α -glycerophosphate. Ubiquinols are re-oxidized by transfer of electrons to the third complex, CoQ-cytochrome C reductase. In yeast, this complex contains cytochromes b and c_1 and an iron-sulphur protein. The cytochrome c pool mediates transfer of electrons between the third and fourth complexes. The latter is cytochrome c oxidase, which contains cytochromes a, a_3 and a copper metalloprotein. Cytochrome oxidase completes the process by transferring electrons to oxygen, generating water.

The fifth complex is an ATP synthase, the activity of which is coupled to the energy liberated by the controlled flow of electrons. This process is accomplished according to the principles of the chemiosmotic theory (Mitchell, 1979). This holds that the electron chain complexes are arranged spatially within the mitochondrial inner membrane such that as electrons flow down their electrical potential, protons are translocated from the inside to the outside of the membrane. Since the membrane is relatively impermeable to protons and other charged species, the electrogenic pumping of protons generates a transmembrane electrochemical potential difference. This has both electrical (charge) and chemical (proton concentration) components. This thermodynamic potential drives the synthesis of ATP via a reversible proton-translocating ATPase or ATP synthase.

Complexes 1, 3 and 4 are associated with proton pumping and hence, indirectly with ATP generation, termed sites I, II and III, respectively. Theoretically, each pair of electrons traversing the whole of the respiratory chain could generate three molecules of ATP. Electrons arising in the mitochondrial matrix from the oxidation of succinate bypass the first phosphorylation site. In practice, actual yields of ATP are lower. In some yeast genera, for example, *Candida utilis*, phosphorylation site I is present during growth under certain conditions of nutrient limitation. However, in *S. cerevisiae*, including brewing strains, the existence of site I has been questioned (Guerin, 1991). Unlike mammalian cells, mitochondria of *S. cerevisiae* oxidize exogenous NAD(P)H, directly via NAD(P)⁺ dehydrogenases located in the outer surface of the inner membrane. These deliver electrons to the common ubiquinone pool and therefore, bypass site I phosphorylation. Systems for transporting NADH into mitochondria do exist in *S. cerevisiae*, for example, the malate – aspartate shuttle (Fig. 12.10). This utilizes a combination of malate dehydrogenase and transamination reactions to transfer reducing equivalents from the cytosol to the mitochondria. In *S. cerevisiae*, it serves to control the concentration of NADH in the cytosol.

The individual complexes of the respiratory chain are susceptible to inhibition by a variety of compounds. These have been used as tools to identify which components are present and their order within the respiratory chain. For example, rotenone inhibits complex I. The lack of effect of this compound on oxidative phosphorylation in *S. cerevisiae* is primary evidence for suggesting that complex I is absent in this yeast. Cyanide, azide and antimycin A, inhibit complexes III, and IV. Oligomycin inhibits complex V, ATP synthase.

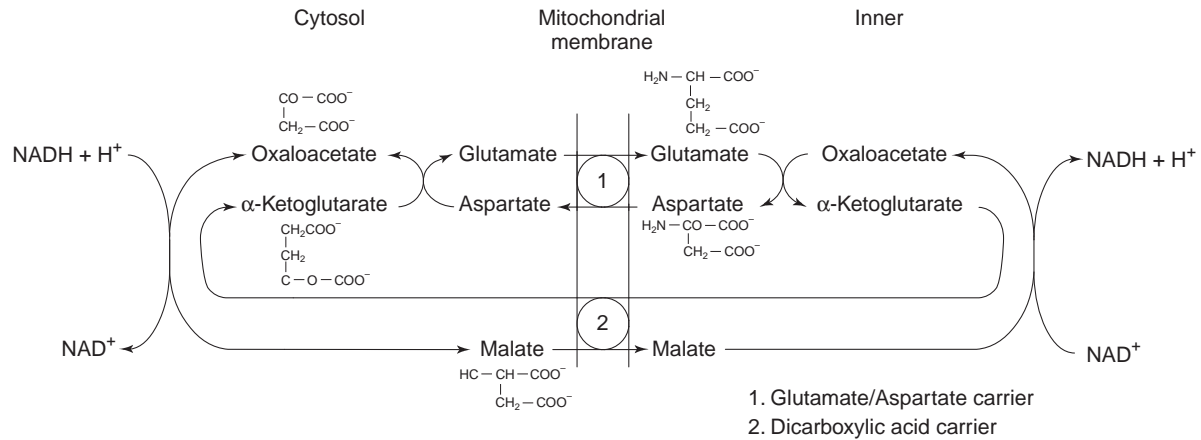

Fig. 12.10 The malate-aspartate shuttle system for transferring reducing equivalents from the cytosol to mitochondria.

In many organisms alternative respiratory systems can be detected that are resistant to cyanide inhibition. There are two types of cyanide insensitive respiration, which are differentiated based on susceptibility to inhibition by salicylylhydroxamic acid (SHAM). The SHAM-sensitive pathway has been detected in several yeast strains, including *Yarrowia lipolytica* and stationary phase cultures of many strains, including *Candida utilis*. The SHAM insensitive pathway has been detected in *S. cerevisiae*, *S. pombe*, *Kluyveromyces lactis*, *Hansenula saturnus* and *Endomycopsis capsularis*. As would be predicted from the lack of sensitivity to cyanide these respiratory pathways are not coupled to energy transduction. It is possible that they function as part of cellular redox control.

12.5.5 Fermentative sugar catabolism

During growth of *S. cerevisiae* on glucose and other repressing carbohydrates, the major product of sugar catabolism is ethanol. A proportion of pyruvate derived from glycolysis is decarboxylated to acetaldehyde, a reaction catalysed by pyruvate decarboxylase. Acetaldehyde is then reduced to ethanol in a reaction performed by NAD⁺-linked alcohol dehydrogenase (Fig. 12.11). In this mode of metabolism ATP is derived solely from glycolytic substrate level phosphorylation and alcohol dehydrogenase is the major redox control route for regeneration of NAD⁺.

In *S. cerevisiae* growing on glucose and to a lesser extent other fermentative sugars, fermentative metabolism is predominant irrespective of the presence of oxygen. Under these conditions, the phenomenon of glucose repression ensures that the genes encoding purely oxidative pathways such as respiratory oxidative phosphorylating electron transport chain are not expressed (Section 12.5.8). Furthermore, enzymes responsible for the utilization of oxidative carbon sources such as ethanol and glycerol are not synthesized and mitochondrial development is arrested. If the glucose concentration falls to a low level (< 0.2% w/w) the metabolism shifts and becomes 'derepressed'. In this

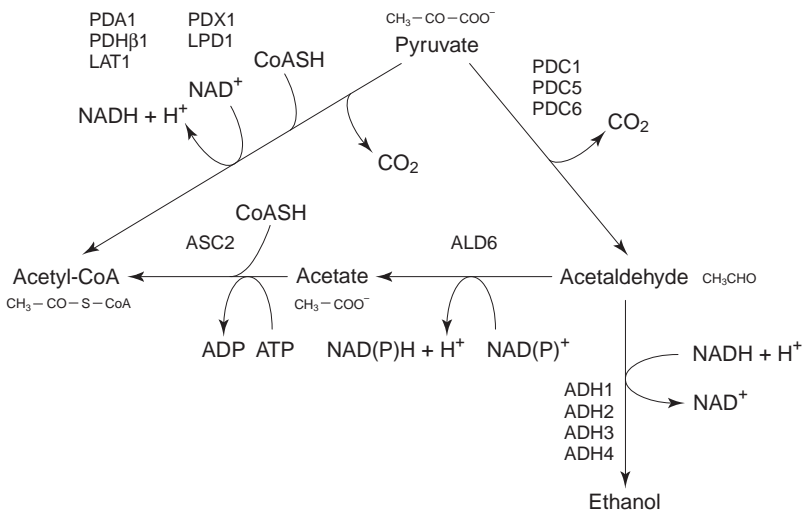

Fig. 12.11 Enzymes of pyruvate catabolism. The genes and enzymes for each step are: PDA1, PDH β 1, LAT1, PDX1, LPD1, pyruvate dehydrogenase complex; PDC1, PDC5, PDC6, pyruvate decarboxylase; ADH1, ADH2, ADH3, ADH, 4, alcohol dehydrogenase; ALD6, aldehyde dehydrogenase (cytosolic); ACS2, acetyl-CoA synthetase (cytosolic).

case, the effects of the glucose signal are abolished and induction of the respiratory metabolic machinery occurs. In the presence of oxygen, the utilization of oxidative substrates, such as ethanol, is coupled to phosphorylation by the electron transport chain. The change in metabolism from fermentative and glucose-consuming to oxidative and ethanol-consuming is an example of diauxie, or a diauxic shift. In other words, the phenomenon of biphasic growth where after the exhaustion of an initial substrate there is a lag phase during which phenotypic adaptation occurs. This results in a second period of growth during which an alternative substrate is utilized.

The branch-point between oxidative and fermentative sugar catabolism occurs at the level of pyruvate. Pyruvate decarboxylase is encoded by three genes, PDC1, PDC5 and PDC6. Of these, PDC1 is the predominant isozyme and is strongly expressed in the presence of glucose. PDC5 appears to be fully expressed only if PDC1 is impaired. PDC 6 expression occurs only during growth on ethanol. Like pyruvate dehydrogenase, pyruvate kinase requires the cofactor, thiamine pyrophosphate for activity.

Yeast alcohol dehydrogenase is encoded by four genes. The ADH1 product is associated with the reduction of acetaldehyde to ethanol since it is induced strongly in the presence of glucose. ADH2 alcohol dehydrogenase is implicated in ethanol utilization since it is repressed by glucose and only active in derepressed cells. The roles of ADH3 and ADH4 are not clear. The former is a mitochondrial enzyme which is induced by glucose, although less strongly than ADH1. The ADH4 enzyme requires Zn^{2+} for activity. It can usually be detected in brewing strains of *S. cerevisiae* but not in laboratory strains. It is possible that in brewery fermentations these enzymes are involved in the formation of higher alcohols and/or the reduction of vicinal diketones (Section 12.10). Possibly, these enzymes have a role in redox control during anaerobiosis.

Under fermentative conditions, the cell has a requirement for acetyl-CoA for biosynthetic reactions, in particular, syntheses of amino acids and fatty acids. Albeit, the total requirement for acetyl-CoA is reduced since the respiratory pathways are not operational. Nevertheless, there must be metabolic regulation of carbon flow between ethanol formation via pyruvate decarboxylase and pathways leading to the formation of acetyl-CoA. In yeast, this may be achieved by regulation of the activities of the pyruvate dehydrogenase complex and pyruvate decarboxylase. In addition, a bypass mechanism may be implicated, whereby acetyl-CoA is derived from acetaldehyde via the concerted action of acetaldehyde dehydrogenase and acetyl-CoA synthetase (Figure 12.11).

At low glucose concentrations there is a concomitant low concentration of pyruvate. Consequently, the pyruvate dehydrogenase route predominates since this enzyme has a higher affinity for pyruvate than pyruvate decarboxylase (Postma *et al.*, 1989). At higher glucose concentrations, pyruvate concentrations also increase and an increasing proportion of the carbon flow is directed towards the formation of acetaldehyde, via pyruvate decarboxylase. This is then converted to acetate and acetyl-CoA through the bypass route. At still higher glucose concentrations, the acetyl-CoA synthetase reaction becomes rate-limiting and ethanol formation occurs, via alcohol dehydrogenase. This shift is further favoured by the increase in pyruvate decarboxylase activity due to glucose activation.

Mammalian pyruvate dehydrogenases are subject to regulation via reversible phosphorylation. A similar mechanism in yeast has not been demonstrated, conclusively. Some control on pyruvate dehydrogenase activity may be exerted at the level of transcription. Under fermentative conditions, pyruvate dehydrogenase may be subject to limited transcription. The latter is controlled in concert with the enzymes of amino acid biosynthesis.

Pyruvate decarboxylase is a cytosolic enzyme, whereas, pyruvate dehydrogenase is mitochondrial, as are the enzymes of amino acid biosynthesis which utilize pyruvate and acetyl-CoA. For the acetaldehyde bypass to be effective acetyl-CoA must cross the mitochondrial membrane. Mitochondrial membranes are accessible to acetate but not acetyl-CoA. Acetyl-CoA synthetases and deacylases occur in both the cytosolic and mitochondrial compartments. In some yeast strains, acetyl units may be transported into mitochondria in the form of acetylcarnitine.

12.5.6 Gluconeogenesis and the glyoxylate cycle

Under aerobic conditions, yeast can utilize a number of non-sugar sources, such as ethanol, glycerol and lactate as sole sources of carbon. For growth to proceed under these conditions the cell must synthesize glycolytic intermediates, some of which are precursors of essential anabolic metabolites. This requires glycolysis to operate in reverse and this process is termed gluconeogenesis (Gancedo and Gancedo, 1997). The majority of the enzymes of glycolysis are freely reversible. However, phosphofructokinase and pyruvate kinase are not. These non-reversible steps are bypassed by two specific gluconeogenic enzymes. Fructose 1,6-bisphosphatase catalyses the conversion of fructose 1,6-bisphosphate to fructose 6-phosphate and phospho-enol-pyruvate carboxykinase catalyses the conversion of oxaloacetate to phospho-enol-pyruvate (Fig. 12.5).

Glycolysis and gluconeogenesis do not occur simultaneously and therefore the direction of carbon flow is regulated. As befits such a crucial crossroad in metabolism, control mechanisms are many and stringent. The presence of exogenous glucose at very low concentration (0.2 mM) totally abolishes gluconeogenesis. Under these conditions, the transcription of FBPI (fructose 1,6-bisphosphatase) and PCK1 (phosphoenolpyruvate carboxykinase) is repressed. The glucose signal does not involve the Ras, cyclic AMP system. Phosphorylation of glucose is required since the repression of the gluconeogenic enzymes is abolished if hexokinase 1, 2 and glucokinase are absent.

When glucose is added to yeast growing gluconeogenically on an oxidative substrate fructose 1,6-bisphosphatase and phosphoenolpyruvate carboxykinase are degraded by proteases, a phenomenon termed catabolite inactivation. Both enzymes are reversibly inactivated by phosphorylation. Fructose 1,6 bisphosphatase is strongly inhibited by AMP and fructose 2,6 bisphosphate. The latter metabolite is a positive effector of 6-phosphofructo-1-kinase. The regulation of the enzymes which produce and degrade fructose 2,6-bisphosphate are part of a glucose- mediated, cyclic AMP-dependent reversible phosphorylation cascade, as described in Section 12.5.8.

The glyoxylate cycle is a part of the gluconeogenic pathway, which is essential for growth on two-carbon substrates such as ethanol and acetate. Essentially, the pathway is a short cut through the TCA cycle that bypasses those irreversible steps that result in a loss of carbon as CO₂. It involves two specific glyoxylate cycle enzymes, isocitrate lyase and malate synthase (Fig. 12.12). Both enzymes are subject to catabolite inactivation when glucose is added to yeast growing gluconeogenically. Isocitrate lyase and the MDH3 malate dehydrogenase are both induced by ethanol and repressed by glucose. The glyoxylate cycle is not operative in brewing fermentations.

12.5.7 Storage carbohydrates

Under some conditions, the carbohydrates trehalose and glycogen accumulate in yeast and under other conditions, they are degraded (Lillie and Pringle, 1980). Since they do not

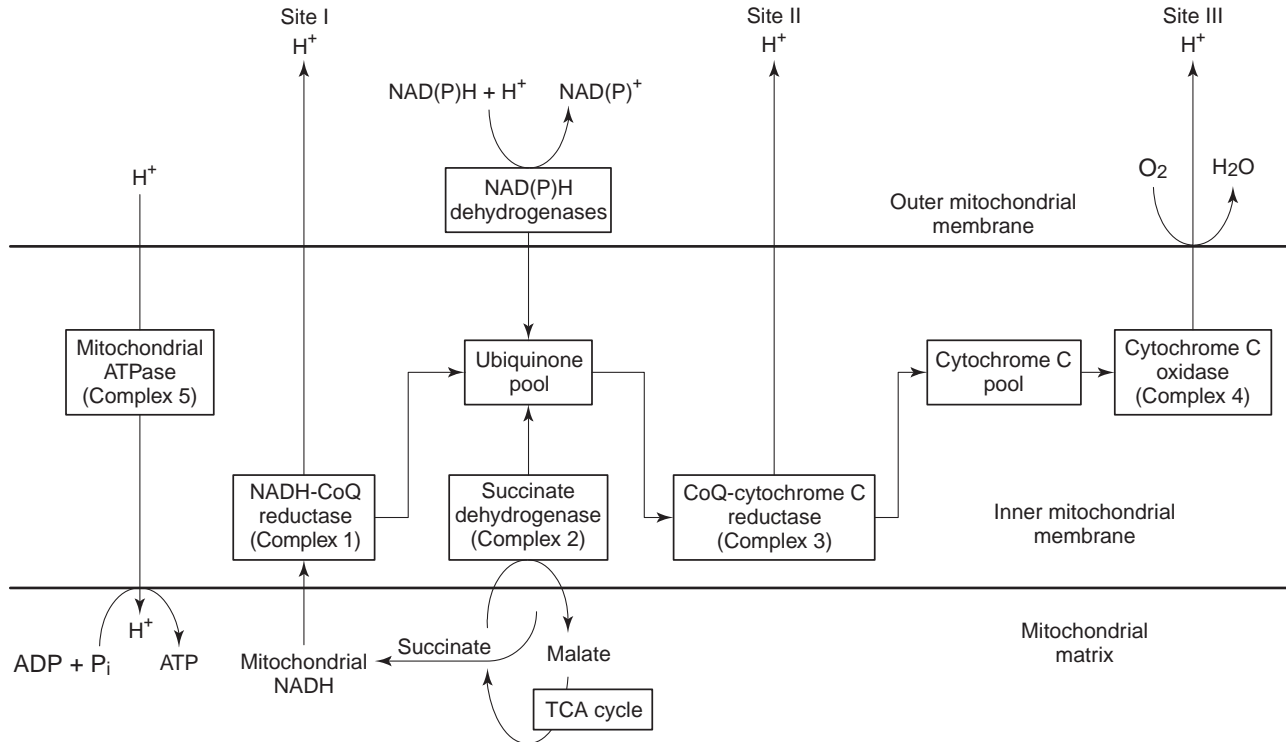

Fig. 12.12 Representation of electron transfer and oxidative phosphorylation in mitochondria (adapted from Alexander and Jefferies, 1990). Note the presence of the three proton-pumping sites and the reverse flow of protons that permits ATP formation.

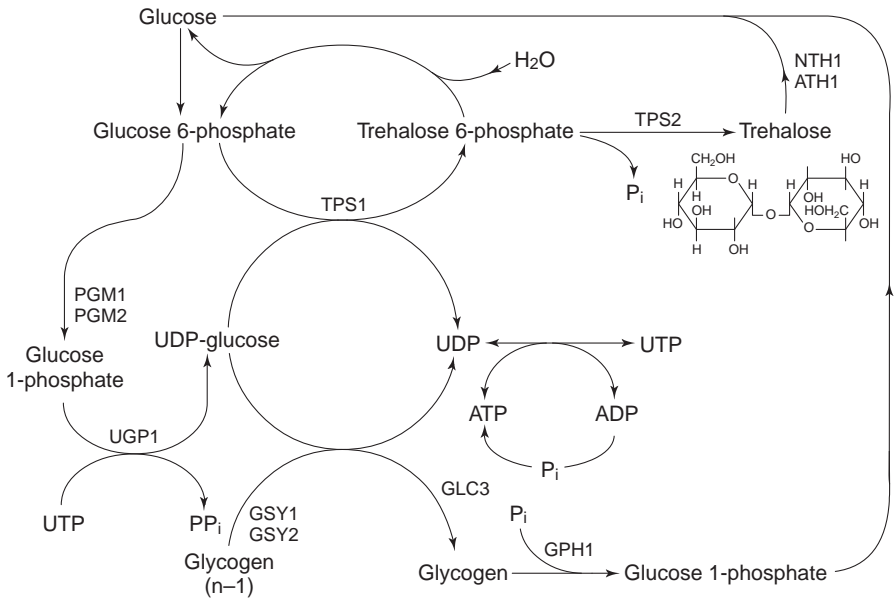

Fig. 12.13 Synthesis and degradation of glycogen and trehalose from and to glucose. The genes and enzymes are: PGM1, PGM2, phosphoglucomutase; UGP1, UDP-glucose pyrophosphorylase; GSY1, GSY2, glycogen synthase; GLC3, branching enzyme; GPH1, glycogen phosphorylase; NTH1, neutral trehalase, ATH1, acidic trehalase (adapted from Francois *et al.*, 1997).

have structural roles, it has been assumed that both function as reserve materials. This appears to be an over-simplistic interpretation. Glycogen is a polymer of α -D-glucose with a molecular weight of approximately 10^8 . It consists of chains of 10–14 residues of α -D-glucose joined by 1 \rightarrow 4 linkages. These chains are cross-linked by (1 \rightarrow 6)- α -D-glucosidic linkages and therefore there are structural similarities to amylopectin. In brewing strains of *S. cerevisiae*, during fermentation, up to 4% of wort sugars are converted to glycogen and it can account for up to 20–30% of the dry weight of the cell (Quain and Tubb, 1982). There are two pools of glycogen in *S. cerevisiae*. The first is soluble and its concentration is modulated in response to changes in physiological state. The second is only solubilized by treatment with acid. It has a structural role, being covalently linked to cell wall β -glucans (Arvindekar and Patil, 2002). Trehalose (α -D-glucopyranosyl-1, 1- α -D-gluconopyranoside) is a disaccharide consisting of two molecules of D-glucose. In commercial preparations of bakers' yeast, trehalose accounts for 15–20% of the cell dry weight. In brewing yeast after fermentation, trehalose concentrations are usually quite modest, typically 2–3% of the dry weight. In yeast recovered from very high-gravity worts (25°Plato, SG c. 1106.1), trehalose levels of 20–25% of the cell dry weight have been reported (Majara *et al.*, 1996a, b).

Glycogen and trehalose are both synthesized from glucose 6-phosphate (Fig. 12.13). Both biosynthetic pathways utilize uridine triphosphate (UTP) to generate the glucose-donor molecule, uridine diphosphate-glucose (UDP-glucose). This reaction is catalysed by UDP-glucose pyrophosphorylase. Trehalose is synthesized by the action of two enzymes, trehalose 6-phosphate synthase (TPS1) and trehalose 6-phosphatase (TPS2). Degradation is via the hydrolase, trehalase, two forms of which occur in yeast. The neutral form (NTH1) is cytosolic and acidic trehalase (ATH1) is located in vacuoles. A second and possibly minor pathway for trehalose has been reported, which utilizes

adenosine diphosphoglucose-dependent trehalose synthase. This is expressed only when maltose or galactose is the carbon source.

Trehalose synthase and phosphatase occur together in a complex. Their gene promoters contain sequences that are found in other genes subject to expression by heat shock (Section 12.9). The vacuolar trehalase has an acidic pH optimum and is constitutive. The cytosolic neutral trehalase is activated by reversible phosphorylation in response to cyclic AMP-dependent protein kinase.

Glycogen biosynthesis begins with a reaction catalysed by an initiator protein and results in the formation of an α -1 \rightarrow 4 glycosyl primer molecule from UDPG. The initiator protein is produced by two genes, CLG1 and CLG2, which are the equivalent of mammalian glycogenin, responsible for *de novo* glycogen synthesis. The primer is then elongated with the formation of α -1,4 linkages by glycogen synthase. The α -1 \rightarrow 6 cross-linkages are synthesized by glycogen branching enzyme, a transglycoylase. Glycogen degradation to glucose 1-phosphate and glucose is accomplished by glycogen debranching enzyme and glycogen phosphorylase.

Glycogen synthase activity is regulated by reversible phosphorylation, possibly under the control of cyclic AMP-dependent kinase, although other kinases may also be involved. In the phosphorylated form, the enzyme is less active. Dephosphorylation is catalysed by a glycogen synthase phosphatase (GLC7). In the active dephosphorylated form, glycogen synthase is subject to allosteric activation by glucose 6-phosphate. Glycogen synthase phosphorylase, the glycogen degradative enzyme occurs in a phosphorylated dimeric active form and a non-active dephosphorylated tetrameric form. Cyclic AMP-dependent kinase may also be involved in the phosphorylation of glycogen synthase phosphorylase, however, it appears that this operates via a second specific glycogen phosphorylase-dependent kinase. The latter may also be active towards glycogen synthase.

Accumulation of glycogen and trehalose occurs when growth is restricted. In a glucose-limiting medium, this occurs when approximately half the glucose has been consumed. In glucose-rich media, it occurs in the late exponential phase when another nutrient is limiting and during the onset of diauxie (Crowe *et al.*, 1984). Accumulation of glycogen is preceded by induction of the enzymes responsible for its biosynthesis and by activation of glycogen synthase by dephosphorylation. These events are accompanied by other global metabolic changes, which it is suggested indicate that the accumulation of glycogen is part of a general nutrient-sensing system (Francois *et al.*, 1997). Thus, the cell responds to imminent starvation of an essential nutrient by accumulating glycogen and by reducing glycolytic flux, reducing overall protein synthesis and inducing heat shock proteins.

The Ras-cyclic AMP cascade system is involved in nutrient sensing. Cyclic AMP concentration is reduced during growth on glucose. It reaches its lowest level at the onset of glycogen accumulation indicating that the cyclic AMP-dependent protein kinase (cPKA) could be implicated. However, glycogen accumulation also requires the activity of another protein kinase, the Snf1 gene product. This kinase is a global regulator whose activity is essential for the entire phenomenon of derepression. With regard to glycogen accumulation, the activities of cPKA and snf1 are antagonistic. Both of these kinases are involved in the regulation of the transcription and post-translational control of genes, which include those encoding the enzymes of glycogen synthesis and degradation.

In brewing, glycogen is used by yeast to provide maintenance energy during the period when yeast is stored in the interval between cropping and re-pitching. Glycogen dissimilation accounts for the small decrease in yeast cell dry weight, which can be seen in the latter phase of fermentation when growth has ceased (Fig. 12.1). In addition, during the aerobic phase of fermentation, glycogen reserves are rapidly mobilized. A linear

relationship has been demonstrated between the quantities of glycogen utilized and sterol synthesized (Quain and Tubb, 1982).

Trehalose concentrations are low in yeast growing exponentially on glucose. Accumulation occurs during the transition between exponential growth and entry into the stationary phase. The synthetic and degradative pathways are both active simultaneously and the actual concentration at any instant represents the balance between the two. The neutral trehalase is activated by phosphorylation by cPKA. Activity of the synthetic complex is also regulated by cPKA. This is not by direct phosphorylation of the enzymes and it seems that the cAMP signal pathway regulates transcription of their respective genes.

Trehalose accumulation in yeast occurs in response to heat shock and some other stresses, such as exposure to hydrogen peroxide. It is assumed that this response renders the cells more resistant to stress. Trehalose confers resistance to elevated temperature in many species (Lillie and Pringle, 1980). This is because trehalose is able to stabilize membranes, where it prevents phase transition events in lipid bilayers. For maximum effectiveness, it must be present at both the inner and outer surfaces of the membrane where it binds to polar heads of phospholipids via the sugar hydroxyl groups. *S. cerevisiae* possesses a trehalose transporter. It has been suggested that as well as being responsible for the uptake of exogenous trehalose, the carrier may also mediate intracellular transport from the cytosol to the plasma membrane and periplasm (Eleutherio *et al.*, 1993).

Following heat shock to *S. cerevisiae*, trehalose 6-phosphate synthase activity increases and neutral trehalase is inactivated. The elevated biosynthetic activity is due to increased expression of the TPS1 and TPS2 genes. In addition, the catalytic activity of the biosynthetic and degradative enzymes alters in favour of trehalose accumulation.

12.5.8 Regulation of sugar metabolism

Sugar metabolism is highly regulated. The energy yield from individual catabolic pathways is very different. During fermentative growth, ATP generation is restricted to substrate level phosphorylation. For each glucose molecule oxidized via glycolysis, there is a net gain of two molecules of ATP. In the case of yeast utilizing oxidative phosphorylation, this value increases to approximately 30 molecules of ATP generated per molecule of glucose oxidized. Yeasts may be classified on the basis of their preferred mode of sugar catabolism. Obligate aerobes make exclusive use of the respiratory pathways and are unable to ferment sugars. They include the genera, *Rhodotorula*, *Lipomyces*, *Cryptococcus*, *Rhodospidium* and *Saccharomycopsis*. Facultative anaerobes may use both respiratory and fermentative pathways. This group is further subdivided based on the proportion of sugars catabolized by each route under aerobic conditions. Respiratory types are predominant and dispose of 70% or more of sugars via respiration. These include *Candida*, *Hansenula*, *Kluyveromyces* and *Pichia*. Fermentative yeasts are typified by high rates of sugar metabolism of which 10% or less is catabolized by respiration. *Saccharomyces* (including all brewing strains), *Brettanomyces* and *Schizosaccharomyces* belong to this category.

A number of phenotypic effects are recognized which describe the patterns of sugar catabolism in various genera growing under certain defined conditions. These are summarized in Table 12.3. The Crabtree effect was originally described in rat ascites tumour cells where it was observed that the addition of glucose resulted in a reduction in respiration rate (Crabtree, 1929). Subsequently, this was ascribed to competition for ATP and inorganic phosphate between glycolysis and respiration. In the presence of glucose, cellular requirements for ATP are satisfied by glycolysis. This results in a reduced

Table 12.3 Mechanisms for the regulation of sugar catabolism in yeast (Boulton and Quain, 2001)

Mechanism	Description
Short-term Crabtree effect	Reduced respiration rate in response to glucose pulse
Glucose catabolite repression and inactivation	Suppression of respiration by glucose
Pasteur effect	Reduction in rate of glycolysis under aerobic conditions
Kluyver effect	Obligate aerobic utilization of disaccharides
Custers effect	Aerobic stimulation of rate of glucose fermentation

requirement for the translocation into the cytosol of ATP produced in mitochondria by oxidative phosphorylation. In turn, this restricts the exchange of cytosolic ADP with mitochondrial ATP. The resultant reduction in mitochondrial ADP concentration restricts oxidative phosphorylation and respiratory rates decline.

This short-term Crabtree effect occurs within minutes of the addition of glucose. A similar phenomenon occurs in yeast and it is accompanied by an immediate increase in the rate of ethanol production. The mechanism may be as described in the preceding paragraph, however it seems more likely that the effect resides in the relative affinity for pyruvate of pyruvate dehydrogenase and pyruvate decarboxylase (Section 12.5.5).

The so-called long-term Crabtree effect describes the repression and inactivation of respiratory enzymes in yeast by the presence of glucose. The underlying biochemistry of this effect is totally different from the short-term Crabtree effect. More properly, it is described as glucose catabolite repression and inactivation. Obligate aerobic yeasts and respiratory facultative anaerobic types exhibit little or no glucose repression. These are termed Crabtree-negative or weakly Crabtree-positive, as appropriate.

S. cerevisiae is a Crabtree-positive yeast. In aerobically growing cultures to which glucose (> 0.2% w/w) has been added, glycolysis becomes the major energy-yielding pathway and ethanol is produced. The expression of several sets of genes are repressed (Table 12.4). The respiratory pathways are inoperative even in the presence of oxygen. Gluconeogenesis is inhibited, as are pathways associated with the utilization of C₂ and C₃ compounds. Glucose repression is accompanied by changes in cell morphology. Thus, the biogenesis of mitochondria and peroxisomes is inhibited. In a parallel series of events, some of the pre-formed enzymes, which are encoded by the genes of glucose-repressible pathways, are inactivated by proteolysis. This phenomenon is termed glucose catabolite inactivation.

The molecular basis of glucose catabolite repression is complex and not yet entirely elucidated. The evidence suggests that two parallel and antagonistic signalling pathways are involved (Stark, 1999). These pathways transmit the signal from the initial glucose trigger to the target genes and bring about the phenotypic changes associated with repression. In addition, in the absence of a glucose trigger, a signal is transmitted which brings about derepression. Thus, derepression is a positive function and is not brought about simply by the absence of a repressing signal.

The initial receptor for the repressing glucose signal is unknown, however, one of the genes encoding for a hexokinase (HXK2) is involved. Thus, the repressing signal is not transmitted unless glucose is phosphorylated after uptake. No glycolytic genes after hexokinase are required for glucose repression and it does not occur in the absence of HXK2. There is circumstantial evidence that the Ras cyclic AMP-dependent protein kinase (cPKA) signal cascade is also implicated. When glucose is added to a yeast culture growing oxidatively under conditions of glucose limitation, there is an immediate increase in intracellular levels of cyclic AMP. The sole function of cyclic AMP in yeast is to activate cPKA. The activities of several enzymes, which take part in pathways

Table 12.4 Genes, electron carriers and enzymes subject to glucose catabolite repression

Gene	Enzyme	Metabolic Function
CYC1	Cytochrome C	Respiratory pathway
COX6	Cytochrome oxidase	
QCR8	Ubiquinol cytochrome C oxidoreductase	
CIT1	Citrate synthase	TCA cycle
ACO1	Aconitase	
KGD1	α -Ketoglutarate dehydrogenase	
MDH3	Malate dehydrogenase (cytosolic)	
MAL61	Maltose permease	
MAL62	Maltase	
SUC2	Invertase	
GAL1	Galactokinase	Galactose uptake and utilization
GAL2	Galactose permease	
GUT1	Glycerol kinase	Glycerol utilization
GUT2	Glycerol 3-phosphate kinase	
FBP1	Fructose 1,6-bisphosphatase	Gluconeogenesis
PCK1	Phosphoenolpyruvate carboxykinase	
ICL1	Isocitrate lysase	Glyoxylate cycle
MLS1	Malate synthase	
ADH2	Alcohol dehydrogenase II	Ethanol utilization
ACS1	Acetyl-CoA synthetase	
POX1	Acyl-CoA oxidase	β -oxidation
POT1	3-Oxoacyl-CoA thiolase	

responsive to glucose repression, are influenced by cPKA. The effect of cPKA may be direct or indirect via other intervening kinases.

The principal components of the signalling pathway mediated by Ras genes are shown in Fig. 12.14. The Ras proteins are subject to post-translational modification. This takes the form of addition of a GTP residue, a reaction catalysed by guanine-nucleotide exchange factor. The latter is the product of another gene (Cdc25p) whose expression is controlled by an, as yet, unidentified metabolite. The GTP-Ras protein is an activator of adenylate cyclase and the activity of the latter catalyses the formation of cyclic AMP (3',5'-cyclic AMP).

Cyclic-AMP-dependent protein kinase (PKA) comprises two regulatory sub-units (Bcy1P) and two catalytic sub-units (TpK). Cyclic AMP binds to the inactive PKA and causes the regulatory sub-units to disassociate. Active PKA is liberated, which is then free to phosphorylate target enzymes and so transmit the glucose signal to the various target metabolic pathways and produce a response. Cyclic AMP is degraded by phosphatases. In addition, cPKA exerts feed back control on cAMP levels by phosphorylation of a component of the Ras transduction pathway.

The antagonistic derepressing signal pathway is mediated by another kinase, Snf1p, levels of which increase rapidly in cells starved of glucose. Snf1p occurs as part of a multi-protein complex. In the presence of glucose the complex autophosphorylates and lacks kinase activity. In the absence of glucose, a protein phosphatase (PP1) is activated by an unknown mechanism. This dephosphorylates the Snf1p-containing complex and as a result of a conformational shift the auto-inhibition is relieved and kinase activity is restored. Snf1p kinase apparently acts on another mediating protein, termed Mig1p. In the

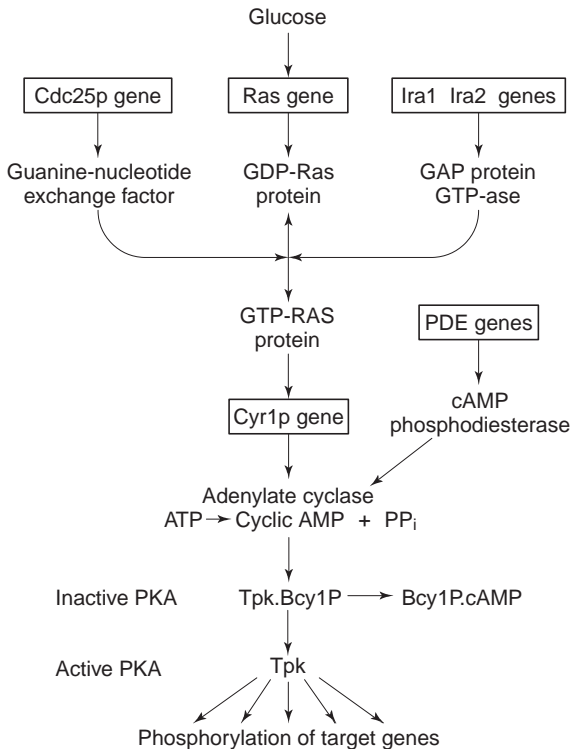

Fig. 12.14 The Ras adenylate cyclase signal transduction system. The abbreviations are defined in the text.

unphosphorylated form this protein binds to the promoter region of glucose-repressible genes and prevents their expression. When Mig1p is phosphorylated by Snf1p it dissociates from the target genes and repression is thereby lifted.

Glucose catabolite repression is of importance in brewery fermentations. In the initial aerobic phase the presence of glucose ensures that metabolism is fermentative. In the later stages of fermentation, although the repressing signal may be absent, depending on the composition of the wort, anaerobiosis ensures that oxidative respiratory metabolism does not develop. The presence of glucose in wort prevents the utilization of the predominant sugar, maltose (Section 12.4.1). In all-malt worts this is of small importance since glucose concentrations are low, relative to maltose. Thus, during the early aerobic phase of fermentation glucose repression prevents the development of respiratory capacity and maltose utilization. However, this effect is transitory such that the disappearance of glucose and the onset of anaerobiosis are roughly coincident. At this stage anaerobiosis prevents the yeast from acquiring respiratory capacity and the disappearance of glucose removes the repressing effect such that maltose can be utilized.

Caution should be exercised with worts containing glucose syrup adjuncts since the resultant prolonged repressing signal may prevent maltose utilization throughout much of the fermentation. In single-stage immobilized yeast reactors designed for primary fermentation glucose repression can have adverse effects. Thus, if throughput rates are too high the continuous addition of glucose in fresh wort can repress maltose utilization. This problem can be circumvented by the use of continuous systems containing two or more discrete stages. In such systems glucose is utilized in the first stage.

The glucose repression phenomenon is influenced by the availability of other nutrients. In the absence of a complete growth medium, glucose-starved cells exposed to glucose exhibit a transient repression response. Following addition of the limiting nutrient, a source of nitrogen for example, the typical glucose repression response is seen. This non-glucose response is identical to that mediated by cyclic AMP-dependent protein kinase (cPKA). However, the effect still proceeds in mutants lacking the regulatory sub-unit of cPKA.

It has been suggested that yeasts require additional controls that prevent the full-blown glucose repression response in the absence of a complete growth medium. When the latter condition is satisfied activation of protein kinase A (PKA) occurs and repression proceeds. The transmission of the initial trigger from the non-glucose nutrient to protein kinase A occurs via a regulatory system that does not involve cyclic AMP. This signalling mechanism is described as the fermentable-growth-medium induced pathway (Thevelein and Hohmann, 1995).

The Pasteur effect is the phenomenon whereby fermentation is inhibited by respiration or glycolytic rates decrease under aerobic conditions (Warburg, 1926). The energetic yield of respiration is more favourable than fermentation and furthermore, yields of cellular biomass per unit of sugar consumed are greater. It would be supposed, therefore, that under aerobic conditions yeast would preferentially use oxidative phosphorylation for the generation of energy and in consequence reduce rates of glycolysis. The magnitude of the Pasteur effect is dependent on the relative respiratory capacities of individual yeast strains. Both *S. cerevisiae* (a fermentative facultative anaerobe) and *Candida tropicalis* (a respiratory facultative anaerobe) growing exponentially on glucose under anaerobic conditions exhibit glycolytic rates of approximately $200 \mu\text{M} \cdot \text{glucose consumed} / \text{min} / \text{g} \cdot \text{dry wt. yeast}$. Under aerobic conditions, the glycolytic rate in *S. cerevisiae* is virtually unchanged, however, in *C. tropicalis* it decreases by more than 90% to approximately $5 \mu\text{M} \cdot \text{glucose consumed} \text{ min}^{-1} \text{ g}^{-1}$ yeast dry weight (Gancedo and Serrano, 1989). In the former yeast, a comparatively small Pasteur effect is observed only in glucose or nitrogen-starved stationary phase cultures.

The mechanism of the Pasteur effect is obscure and possibly differs depending on cultural conditions and the nature of the yeast. In derepressed cells undergoing a transition from anaerobiosis to aerobiosis the effect may be due to simple competition for pyruvate. Since pyruvate dehydrogenase has a higher affinity for pyruvate compared to pyruvate decarboxylase the presence of oxygen allows carbon to be diverted towards respiratory pathways and fermentation rates decline. In yeast such as *S. cerevisiae* with an inherently limited respiratory capacity, this effect is small. Decrease in glycolytic rates by aerobiosis appears to involve feed-back control from oxidative phosphorylation. The mechanism is unknown although it has been suggested that glycolytic rates might be modulated by the effect of phosphate on the activity of phosphofructokinase (Gancedo and Serrano, 1989). The proposal is that under anaerobic conditions, flux through oxidative phosphorylation is reduced and this results in an increase in phosphate concentration. In turn, this activates phosphofructokinase and glycolytic activities are stimulated. Other mechanisms regulating sugar metabolism in various genera of non-brewing yeasts have been discovered, for example the Custers and Kluyver effects. These are described elsewhere (Boulton and Quain, 2001).

12.5.9 Ethanol toxicity and tolerance

The biochemistry underlying the formation of ethanol from the catabolism of sugars is described in Section 12.5.5. With regard to commercial fermentations, in which ethanol is

a major product of yeast metabolism, the rate of ethanol formation and the maximum concentration formed may be important considerations. In the case of the fermentation of high-gravity worts the ability of yeast to withstand high concentrations of ethanol is an influential factor in strain selection. Brewing yeast strains are exposed to ethanol concentrations typically in the range of 3–6% v/v. In high-gravity brewing ethanol concentration may be as high as 10% v/v. Wine yeasts are considered more ethanol tolerant than their brewing counterparts. In wine fermentations, final ethanol concentrations of 10–15% v/v are usual. In extreme cases such as Tokay wines and the rice ‘wine’ saké, the fermentations generate in excess of 20% v/v ethanol.

The ability to tolerate ethanol is usually considered to have a genetic basis. Exposure of yeast to very high ethanol concentrations results in the inhibition of growth and ultimately death. There is no precise definition of ethanol tolerance in yeast. Some strains are more able than others to withstand the deleterious effects of ethanol. Of course, it is possible that intermediates of ethanol formation or other products of fermentation exert deleterious effects on yeast. In addition, in order to generate high ethanol concentrations during fermentation, it is necessary to provide a high initial concentration of fermentable sugar. In this case, the ability to grow under conditions of low water activity may be of greater or equal importance to ethanol tolerance, *per se*. In order to ferment concentrated worts it is essential that other nutrients are available in balanced quantities. This is an important consideration in high-gravity brewing where the injudicious use of sugar adjuncts may result in wort that is deficient in non-sugar nutrients.

Ethanol inhibits yeast growth in a non-competitive manner. It does not have any specific inhibitory effect on glycolytic rate. Many reports describe morphological changes in response to ethanol exposure, for example, the development of cell surface invaginations and cell shrinkage (Pratt-Marshall *et al.*, 2002). The toxic effects are apparently more severe when ethanol is generated endogenously compared to the same concentration added to the medium (Nagodawithana and Steinkraus, 1976). This observation prompted the suggestion that the effect was a consequence of intracellular accumulation of ethanol during fermentation. However, this assertion has been refuted. It appears that the plasma membrane is freely permeable to ethanol such that intracellular accumulation occurs only during very early fermentation (D’Amore *et al.*, 1988). Other aliphatic alcohols also exert inhibitory effects. The severity of the inhibition is proportional to the chain-length of the molecule.

Several mechanisms have been proposed by which the toxic effects of ethanol may be exerted. These include non-specific osmotic effects (Jones and Greenfield, 1987) and a number of specific target sites (D’Amore *et al.*, 1990; Mishra, 1993). A high concentration of intracellular ethanol reportedly denatures some enzymes. Exposure to ethanol has a mutagenic effect on mitochondrial DNA as indicated by an increase in the occurrence of respiratory petites. The major site for ethanol toxicity appears to be the plasma membrane and other intracellular membranes. Several effects have been observed which relate to membrane function. These include leakage of cellular components, abolition of membrane proton motive potential, inhibition of transport systems and alterations in membrane structure and fluidity. The fact that the membrane is the primary target explains the observation that longer chain-length alcohols have enhanced toxicity. Thus, there is a concomitant increase in hydrophobicity and consequently easier interaction with membrane lipids.

The observation that endogenously generated ethanol is more toxic than added ethanol at similar concentration suggests that other intermediates of ethanol biosynthesis might be influential. Potential candidates include short chain fatty acids, higher alcohols, acetate and in particular acetaldehyde (Jones, 1987). The argument is perhaps most

persuasive in the case of acetaldehyde since reportedly, it is an order of magnitude more toxic to yeast than ethanol and is the immediate precursor of ethanol (Jones, 1989). However, the fact that acetaldehyde can accumulate in yeast cells, under some conditions, to a greater concentration than seen in fermentation and apparently with no toxic effect provides a powerful counter-argument (Stanley and Pament, 1993). It is perhaps most likely that intermediates of ethanol metabolism may contribute to ethanol toxicity in a synergistic fashion.

Yeast cells exhibit various adaptations in response to exposure to ethanol. Ethanol elicits a stress response such that there is a concomitant acquisition of thermotolerance and barotolerance (Hisada *et al.*, 2002). In addition, there is an increase in levels of intracellular trehalose (Mansure *et al.*, 1994). Since trehalose is a membrane-stabilizing agent (Section 12.5.7), this response is explained. The lipid composition of membranes is altered such that there is an increase in the content of unsaturated fatty acids and 5,7-unsaturated sterols and a decrease in saturated lipids. Of course, this response is not possible in a brewing fermentation where these syntheses are precluded by anaerobiosis. The toxic effects of ethanol are reportedly ameliorated by the presence of Mn-superoxide dismutase, the mitochondrial enzyme implicated in resistance to oxidative stress Costa *et al.*, 1993). This enzyme is induced under oxidative conditions. Therefore, it would not be active under the conditions of a brewing fermentation (Section 12.6).

The tolerance of yeast to ethanol can be influenced by manipulation of the growth medium. Predictably, supplementation of the medium with a source of unsaturated fatty acids is beneficial in this regard. A considerable body of evidence has now been amassed indicating that the addition to growth media of various metal ions provides protection against ethanol stress. In particular, calcium and magnesium have been reported to have beneficial effects (Dombek and Ingram, 1986; Ciessarova *et al.*, 1996). It has been suggested that wort may not contain optimal concentrations of these metal ions (Walker *et al.*, 1996; Rees and Stewart, 1997). This can be remedied by supplementation with magnesium to ensure that the ratio of this metal ion to calcium is always high. The mechanism by which metal ions exert protective effects is not clear.

12.6 The role of oxygen

Oxygen presents yeast with both an opportunity and a threat. Facultative anaerobic strains such as brewing yeasts have the ability to grow either oxidatively or fermentatively. The effects of glucose catabolite repression in Crabtree positive yeast are relieved in the absence of a glucose signal. However, development of complete respiratory competence requires the presence of oxygen. Thus, aerobiosis provides yeast with the opportunity of utilizing the energetically favourable oxidative route for energy production. However, oxidative metabolism is accompanied by the generation of potentially harmful reactive oxygen radicals. Consequently, yeast must have enzyme systems for removal of oxygen radicals and nullifying this potential threat.

Three classes of genes in *S. cerevisiae* are recognized based on their response to oxygen tension (Zitomer and Lowry, 1992). Some genes are expressed only under anaerobic conditions. The role of many of these is unknown, however, some are involved in the assimilation of nutrients from the medium which otherwise require oxygen for their synthesis. Hypoxic genes are expressed strongly under micro-aerophilic conditions and are apparently required for the efficient utilization of low oxygen concentrations. The expression of more than 200 genes is required for aerobic respiratory growth (Tzagoloff and Dieckmann,

1990). Many of these are expressed only under aerobic conditions. These include components of the electron transport chain such as ubiquinone and cytochrome oxidase.

The signal pathway by which molecular oxygen exerts its effects upon metabolism is unknown. However, as described in the previous section in the hierarchy of signalling pathways, it plays a subordinate role to glucose repression. Haem is a key intermediate in the oxygen-sensing pathway. Formation of the haem precursor, protoporphyrin-IX is via the oxidation of coproporphyrinogen-III. This is the rate-determining step in haem biosynthesis. Consequently, haem content and oxygen tension are directly related (De Winde and Grivell, 1993). In addition to its role as a prosthetic group in molecules such as cytochromes, haem is an effector metabolite in many pathways that utilise molecular oxygen. It is involved in the positive regulation of expression of genes encoding respiratory enzymes and those that play a part in protecting the cell against oxygen radicals. Conversely, haem represses the expression of several genes that are redundant under anaerobic conditions. These include some of those responsible for the synthesis of sterols and unsaturated fatty acids.

Brewing yeasts do not develop respiratory competence under the conditions encountered in fermentation. Thus, in the aerobic phase of fermentation, respiratory pathways are repressed because of the presence of sugars. In late fermentation when the sugars have disappeared and their repressing effects are relieved, anaerobiosis prevents the induction of the respiratory enzymes.

The majority of yeasts require oxygen for growth. In a study of type species from 75 genera, it was noted that only 23% could grow under anaerobic conditions on a complex medium supplemented with ergosterol and a source of unsaturated fatty acids (Visser *et al.*, 1990). Of these, *S. cerevisiae* was exceptional in that it was capable of rapid growth at low oxygen tension. Nevertheless, none of these yeasts, including *S. cerevisiae*, can grow under totally anaerobic conditions unless the medium is supplemented with a source of unsaturated fatty acids and sterols (Andreason and Stier, 1953a,b). These essential metabolites can be assimilated from the medium or synthesized *de novo* from carbohydrates. Synthesis requires the presence of molecular oxygen. Both of these are present in wort at the start of fermentation.

In brewery fermentations, sterols and unsaturated fatty acids are synthesized during the aerobic phase. Cell proliferation during the anaerobic phase of fermentation dilutes the pre-formed pools of sterols and unsaturated fatty acids amongst daughter cells. On subsequent re-pitching, these lipids must be replenished hence the requirement for oxygenation of wort. Failure to provide sufficient oxygen is one of the prime causes of slow and sticking fermentations. The quantity of oxygen required for fermentation is strain-dependent. In an early study, ale strains were classified as requiring half air saturation, air saturation, oxygen saturation or more than oxygen saturation for satisfactory fermentation performance (Kirsop, 1974). Similar findings have been reported for lager yeast strains (Jacobsen and Thorne, 1980). The explanation for these differences is related to the spectrum of sterols produced by individual yeast strains (Section 12.7.3). The fate of most of the oxygen utilized during the aerobic phase of fermentation is unknown. Theoretically 10% is utilized for sterol formation and 15% for the biosynthesis of unsaturated fatty acids (Kirsop, 1982). More than 50% is unaccounted for.

During fermentative growth, yeast forms ATP via cytosolic substrate level phosphorylation since the mitochondrial oxidative electron transport is inoperative. Many essential energy-requiring enzyme systems are located within promitochondria, the undifferentiated organelles characteristic of fermentative yeast. Adenine nucleotides are transported between the cytosol and mitochondria via an ADP/ATP translocase. Three

isozymes of ADP/ATP occur in *S. cerevisiae*, one that is constitutive, a second induced in respiratory cells and a third induced by anaerobiosis (Kolarov *et al.*, 1990). It is proposed that the latter enzyme catalyses transfer of ATP from the cytosol into mitochondria during fermentative growth.

Oxygen radicals are highly reactive species, which are implicated in damaging effects such as lipid peroxidation, mutagenesis and other degenerative changes associated with ageing and senescence. Yeast, in common with other cells, possesses protective mechanisms for removing oxygen radicals (Krems *et al.*, 1995). The precursor of sterols, squalene, reportedly scavenges free radicals in mammalian cells (Kohnno *et al.*, 1995). Squalene accumulates in yeast under anaerobic conditions (Table 12.6 on page 447) and it could fulfil a similar role. Similarly, reduced glutathione reacts with superoxide, hydrogen peroxide and larger hydroperoxides. The two major protective enzymes are superoxide dismutase (SOD) and catalase (Fridovich, 1986). These enzymes, acting in concert, convert the superoxide radical to oxygen and water.

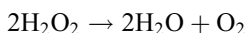
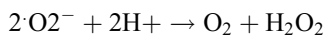

Yeast cells possess two superoxide dismutases, a cytosolic CuZn SOD and a mitochondrial Mn SOD. Mutants lacking both isozymes are hypersensitive to oxygen. The cytosolic CuZn SOD is constitutive and highly expressed in aerobic cultures and those grown on non-fermentable substrates. The mitochondrial Mn SOD is induced by oxygen and it is not present in cells growing fermentatively. In brewing yeast, under non-growth conditions during a transition from anaerobiosis to aerobiosis, there was a rapid increase in the specific activity of CuZn SOD. The specific activity of the Mn SOD increased only after several hours exposure to oxygen (Clarkson *et al.*, 1991). The transition was accompanied by a decrease of 5–7% in the viability of the culture. It was concluded that the CuZn SOD was protective in anaerobic yeast, whereas the Mn SOD was important only in aerobic cultures.

Two forms of catalase occur in yeast, a cytosolic form (catalase T, CTA1 gene) and a peroxisomal form (catalase A, CTT1 gene). Both are haemoproteins. CTA1 is induced by oxygen and growth on non-fermentable substrates such as fatty acids. It is repressed by glucose. CTT1 is also induced by oxygen and it requires haem for its expression. In addition, it is induced in response to stresses such as heat shock, low water activity and oxidative stress (Dawes, 1999). These observations have resulted in the suggestion that catalase T is involved in hydrogen peroxide removal during the stationary phase, whereas, catalase A is protective towards sudden oxidative stress.

12.7 Lipid metabolism

Lipids are a diverse group of compounds that are characterized by the common property of sparing solubility in water but being soluble in organic solvents. They have important structural roles, especially in membranes. Frequently they form part of larger macromolecules where the hydrophobic nature of the lipid moiety confers specific properties. Many lipids have biological roles in signalling systems, as vitamins and in receptor sites on cell surfaces.

S. cerevisiae, contains relatively modest levels of lipids, typically 5–15% of the cell dry weight (Ratray, 1988). The predominant classes of lipid are sterols (both free and

Table 12.5 Lipid composition (% total lipid) of various strains of *S. cerevisiae* (adapted from Rattray, 1988)

Strain	TAG	DAG	MAG	FFA	S	SE	PL	Other
1	7.4	–	–	4.1	4.3	21.9	61.7	–
2	23.9	12.9	–	1.9	–	23.9	26.9	10.4
3	8.2	1.3	0.9	1.9	6.6	53.3	27.7	–
4	7.4	0.3	0.8	0.8	4.7	45.4	38.3	–
5	9.6	5.8	–	2.3	–	25.3	56.9	–
6	40.4	4.3	–	5.8	–	19.6	29.9	–
7	12.6	4.9	–	–	3.0	8.4	28.1	–
8	8.6	2.3	0.6	1.4	7.2	46.5	33.4	–
9	9.5	1.4	1.7	0.6	5.6	49.0	32.2	–
10	14.4	–	–	1.2	1.7	25.4	52.0	5.4
11	11.8	2.8	3.5	8.8	17.3	26.5	29.2	–
12	16.8	2.8	4.4	9.2	11.0	28.3	27.5	–
13	15.1	4.9	5.3	15.8	21.1	21.1	16.8	–

TAG, triacylglycerol; DAG, diacylglycerol; MAG, monoacylglycerol; FFA, free fatty acids; S, sterol; SE, steryl esters; PL, phospholipids.

esterified), phospholipids and triacylglycerols. Fatty acids, either free or esterified as diacylglycerols and monoacylglycerols make up most of the remaining lipid (Table 12.5). The predominant saturated fatty acids are palmitic (16:0) and stearic (18:0) with smaller amounts of myristic (14:0) and lauric (12:0). Unsaturated fatty acids are mainly palmitoleic (16:1), oleic (18:1) and linoleic (18:2).

12.7.1 Fatty acid metabolism

Fatty acids are synthesized from acetyl-CoA. The latter may arise via several routes. Principally, it is derived from glucose catabolism from pyruvate, directly or via acetaldehyde, acetate and acetyl-CoA synthetase. It is formed from the catabolism of amino acids, leucine, lysine, tryptophan, tyrosine and phenylalanine. In addition, acetyl-CoA is the end-product of the β -oxidation pathway for the degradation of fatty acids.

The biosynthetic pathway to fatty acids involves the action of two enzyme systems, acetyl-CoA carboxylase and the fatty acid synthase complex. Acetyl-CoA carboxylase catalyses the conversion of acetyl-CoA into malonyl-CoA. The reaction is complex and is driven by the breakdown of ATP. The additional carbon atom is derived from bicarbonate ion in a reaction involving the coenzyme biotin.

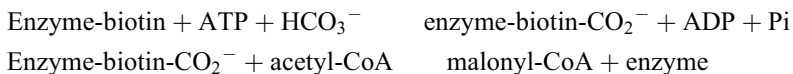

Acetyl-CoA carboxylase is encoded by the gene ACC1. A second gene ACC2 encodes a biotin-apoprotein ligase which catalyses the addition of the biotin moiety to the ACC1 gene product and converts it from the inactive apo- to the active holo- form. Acetyl-CoA carboxylase is considered the rate-determining step in fatty acid biosynthesis. It is activated allosterically by citrate and isocitrate.

Fatty acid synthase (FAS) is a multienzyme complex that catalyses a sequence of reactions in each cycle of which a fatty acid is lengthened by two carbon atoms. (Fig. 12.15). The two carbon atoms are donated by malonyl-CoA deriving from the activity of acetyl-CoA carboxylase. The FAS complex contains acyl carrier protein (ACP) which contains 1'-phosphopantetheine as a prosthetic group. During the sequence of reactions,

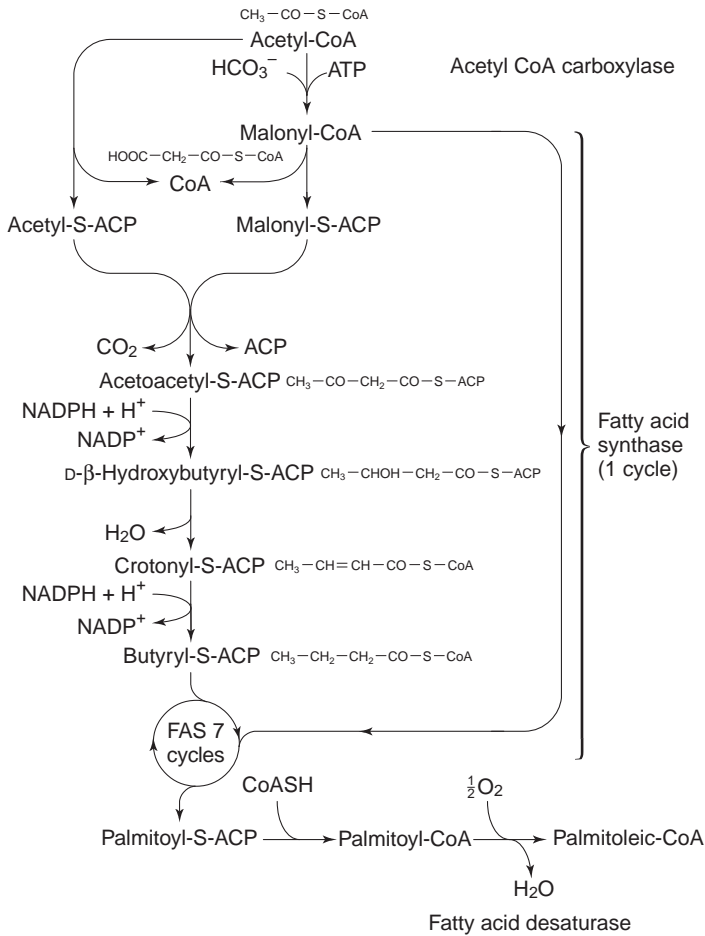
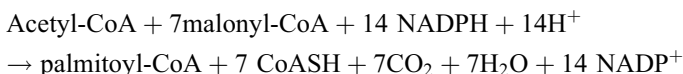

Fig. 12.15 Pathway for the biosynthesis of saturated and unsaturated fatty acids (ACP = acyl carrier protein).

intermediates and substrates are bound to the SH-group of ACP via thioester linkages. Activation of FAS requires activity of phosphopantetheinyl transferase, which attaches the 1'-phosphopantetheine arm to a serine residue in ACP.

Each cycle of reactions involves a priming step in which acyl groups are transferred from CoA to ACP. This is followed by a condensation reaction where the acyl and malonyl groups are combined with the loss of the third carbon atom as CO₂. Finally, there are two reductive steps involving the coenzyme, NADPH+H⁺ and an intermediate dehydration step. Seven successive cycles of the FAS complex leads to the formation of the C16:0 fatty acid ester, palmitoyl-CoA.



Unsaturated fatty acids (UFA) are produced by the action of the enzyme, Δ-9- fatty acid desaturase, which inserts a double bond into fatty acid under aerobic conditions. Multiple desaturation reactions result in the synthesis of di- and trienoic acids such as linoleic (18:2) and linolenic (18:3) acids. The desaturase enzyme is encoded by the gene

OLE1. The enzyme is located in the endoplasmic reticulum and its activity is linked to an NADPH-dependent cytochrome b_5 reductase. Activity of the desaturase is regulated by the presence of exogenous UFA. Unsaturated fatty acids apparently cause rapid degradation of the OLE1 mRNA (Gonzales and Martin, 1996).

Fatty acids, both saturated and unsaturated, eventually become located in membranes where they have structural roles. The relative chain lengths and degrees of unsaturation are influenced by environmental conditions. For example, as the growth temperature is reduced there is a need to maintain membrane fluidity. This is achieved by increasing the degree of unsaturation of the fatty acids in membrane lipid components. In addition to desaturases, *S. cerevisiae* also possesses a membrane-bound fatty acid elongation system, encoded by the ELO genes. These are independent of the FAS system and are used to elongate short chain fatty acids (C10–C12) assimilated from the medium to C16–C18. The elongation reactions occur prior to insertion of fatty acids into membranes (Schweizer, 1999).

It would be predicted that traditional lager fermentations performed at relatively low temperatures would have an increased requirement for UFA as a consequence of the correlation of the latter and membrane fluidity. This possibility appears not to have been explored in detail although it has been reported that UFAs are essential for satisfactory fermentation performance. This effect was ascribed to the requirement for UFA for proper mitochondrial development and function (O'Connor-Cox *et al.*, 1993). UFAs are reported to influence the formation of esters (12.10.4). Linoleic acid reduces the formation of acetyl esters, reportedly by the repression of ATF1, the gene encoding alcohol acetyltransferase (Fuji *et al.*, 1997).

Fatty acid biosynthesis occurs in the cytosol, although there is evidence that yeast may possess a second mitochondrial fatty acid synthase (Schneider *et al.*, 1997). Fatty acid degradation in *S. cerevisiae* occurs in peroxisomes via β -oxidation. The process consists of a cyclic two-carbon shortening of fatty acids catalysed by a series of enzymes encoded by FOX genes. The first and rate limiting step in the pathway is catalysed by an acyl CoA oxidase and converts fatty acyl-CoA esters to *trans* 2,3-dehydroacyl-CoA esters and hydrogen peroxide. The reaction utilizes flavin adenine nucleotide (FAD) as cofactor and this transfers electrons directly to molecular oxygen. Hydrogen peroxide is degraded by the peroxisomal catalase A. In the next sequence of reactions, catalysed by a multifunctional enzyme, *trans* 2,3-dehydroacyl-CoA esters are successively modified by the action of *trans* 2-enoyl CoA hydratase and 3-hydroxyacyl CoA dehydrogenase. Finally, 3-ketoacyl CoA thiolase releases a molecule of acetyl-CoA leaving a residual acyl-CoA chain two carbon atoms shorter than the original.

The three enzymes of β -oxidation are induced during growth on fatty acids under aerobic conditions. In addition, the first enzyme, acyl-CoA oxidase is repressed by glucose. Fatty acids are transported from the cytosol into peroxisomes via transporters specific for medium chain length and long chain length fatty acids. The acetyl-CoA generated by β -oxidation is transported back into the cytosol via a carnitine/acetylcarnitine shuttle system or as citrate. In the latter case, the acetyl-CoA is acted upon by a peroxisomal citrate synthase. In view of the susceptibility to glucose repression and requirement for oxygen, β -oxidation is unlikely to play any part in brewery fermentations.

12.7.2 Phospholipids

Fatty acyl-CoA esters are trans-esterified to form acylglycerols via the phosphatidic acid pathway. The free 1,2-hydroxyl groups of glycerol 3-phosphate are acylated by two

molecules of fatty acyl-CoA to yield a phosphatidic acid. The phosphate is removed from the latter by a phosphatase. The resultant diacylglycerol reacts with a third molecule of fatty acyl-CoA ester to form a triacylglycerol. Two phosphatidic acid phosphatases occur, one microsomal and another that is located in mitochondria. The microsomal enzyme is subject to regulation by the Ras cyclic AMP-dependent protein kinase. In non-oleaginous yeasts, such as brewing strains, triacylglycerols are synthesized only when the fatty acid requirement for phospholipids is satisfied. Triacylglycerols accumulate with steryl esters in cytosolic lipid granules. The fatty acids may be mobilized by the action of lipases, providing an alternative source of fatty acids for phospholipids synthesis.

The major phospholipids in yeast are glycerophospholipids. In *S. cerevisiae* the predominant types are phosphatidylcholine, phosphatidylethanolamine, phosphatidylinositol and phosphatidylserine (Ratray, 1988). Phospholipids consist of a molecule of glycerol in which one of the hydroxyl groups is esterified to phosphoric acid and the other two to fatty acids. The phosphate head group form ester linkages with molecules such as amino acids and alcohols to give the phospholipids detailed above. The combination of polar head group and hydrophobic fatty acyl chains confers amphipathic properties on phospholipids, which makes them suitable for insertion into membranes. Inositol phospholipids have roles in cellular signalling systems and they are involved in the regulation of protein sorting across intracellular membranes.

Like acylglycerol lipids, phospholipids are synthesized from phosphatidic acids (Fig. 12.16). Phosphatidylcholine and phosphatidylethanolamine are formed from diacylglycer-

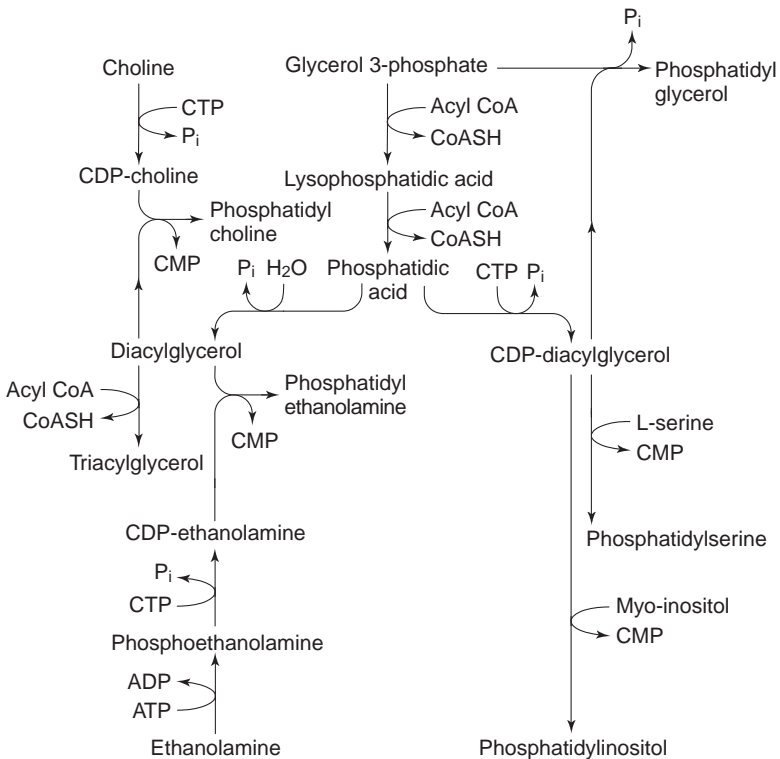

Fig. 12.16 Synthesis of phospholipids and acyl-glycerol lipids via the phosphatidic acid pathway. CTP = cytidine 5'-triphosphate, CDP = cytidine 5'-diphosphate, CMP = cytidine 5'-monophosphate.

ols. Phosphatidylglycerol (cardiolipin), phosphatidylserine and phosphatidylinositol are synthesized from the common precursor, CDP-diacylglycerol. Phospholipids are synthesized in reactions that involve the carrier molecule, cytidine 5'-diphosphate (CDP). Phospholipids are degraded by specific phospholipases that remove the fatty acyl groups from the glycerol molecule.

12.7.3 Sterols

Sterols, like unsaturated fatty acids, are formed during the initial phase of wort fermentation when oxygen is available. The most abundant sterol in yeast is ergosterol. In brewing strains, smaller quantities of zymosterol, episterol, lanosterol, and fecosterol can also be detected (Table 12.6). Sterols are essential components of cell membranes where, in conjunction with phospholipids, they confer fluidity. Sterols are most abundant in the plasma membrane, where they occur in the free form. Some 90% of the sterol in the plasma membrane is ergosterol. The smaller quantities of other sterols are probably pools of intermediates in the ergosterol biosynthetic pathway. Membranes surrounding intracellular organelles contain smaller quantities of sterols. Lipid granules, which contain cellular reserves of triacylglycerol, also contain sterols esterified to fatty acids.

The starting point for sterol synthesis is acetyl-CoA. The latter may arise from the catabolism of wort sugars via glycolysis. However, in the early phase of brewery fermentations membrane function of pitching yeast may be impaired by sterol depletion. Consequently, it has been suggested that the carbon and energy for sterol synthesis could be supplied by mobilization of glycogen reserves. A linear correlation between glycogen breakdown and sterol synthesis during the aerobic phase of wort fermentation has been demonstrated (Quain and Tubb, 1982). Yeast can utilize exogenous sterols. This occurs only under anaerobic conditions when *de novo* synthesis is precluded by the absence of oxygen. This phenomenon has been termed aerobic exclusion (Parks and Casey, 1995). By inference, any sterols present in wort would not be utilized during the initial aerobic phase of fermentation.

In the first part of the sterol biosynthetic pathway, three acetyl units are combined to form a molecule of mevalonate (Fig. 12.17). Mevalonate is then converted to 3-isopentenyl pyrophosphate in a sequence of phosphorylation reactions in which three molecules of ATP are hydrolysed. Thus, sterol synthesis is expensive in terms of the expenditure of metabolic energy. A molecule of 3-isopentenyl pyrophosphate and its isomer, 3-3-dimethylallyl pyrophosphate then condense with a loss of pyrophosphate to form the monoterpene derivative, geranyl pyrophosphate. This reacts with another molecule of 3-isopentenyl pyrophosphate to form the sesquiterpene derivative, farnesyl

Table 12.6 Squalene and sterol composition of lager pitching yeast (S. C. P. Durbin, unpublished data)

Component	% Dry wt.
Squalene	1.2
Ergosterol	0.095
Lanosterol	0.055
4,4-Dimethylzymosterol	0.022
Zymosterol	0.01
Ergosta-7, 22-dienol	0.009
Dihydroergosterol	0.007

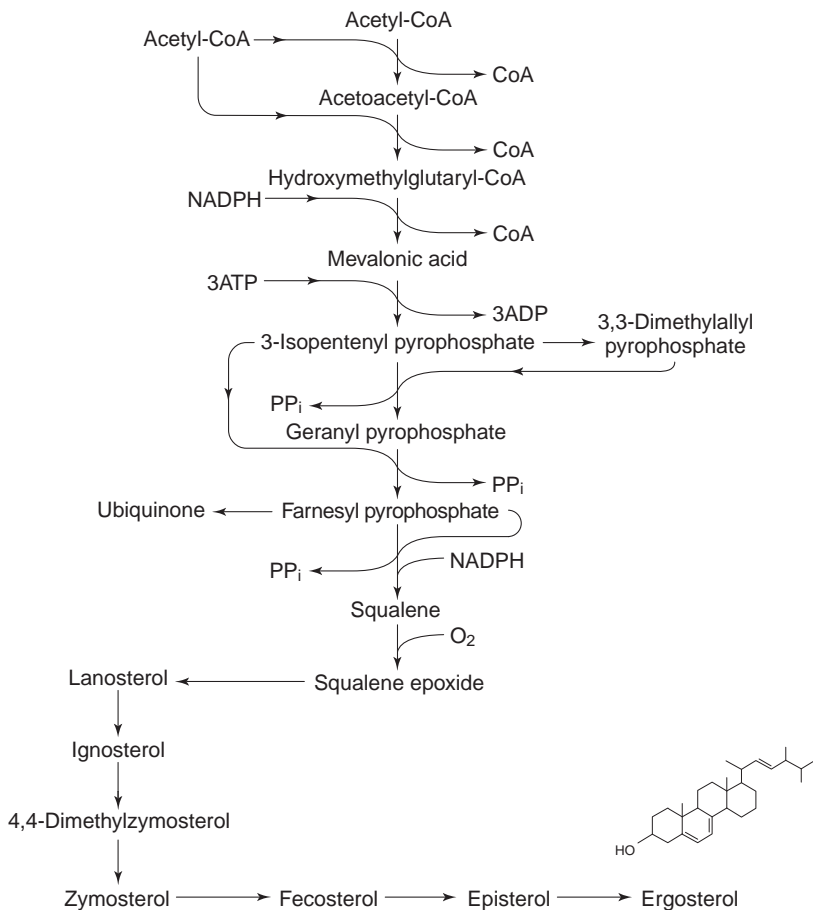

Fig. 12.17 Biosynthetic pathway of ergosterol from acetyl-CoA.

pyrophosphate. This metabolite is also a precursor for haem and ubiquinone biosynthesis. Two molecules of farnesyl pyrophosphate condense to give presqualene pyrophosphate, which is then reduced by NADPH with a loss of pyrophosphate to form squalene.

The initial part of the sterol biosynthetic pathway is an anaerobic process. The biosynthesis of ergosterol from squalene requires molecular oxygen. The precise steps of the biosynthetic pathway differ in individual strains but a generalized scheme is shown in Fig. 12.17. Oxygen is utilized in the first step in which squalene is converted to the epoxide, 2,3-oxidosqualene. Some of the subsequent steps utilize cytochrome P450 oxygenases, which also require molecular oxygen.

Sterol biosynthesis is highly regulated. The key step in the early part of the pathway is the formation of mevalonate from hydroxymethylglutaryl-CoA (HMG-CoA), catalysed by HMG-CoA reductase. This step is thought to be the rate-limiting step in the biosynthesis of sterols and other isoprenoids (Schweizer, 1999). Two isozymes of HMG-CoA reductase occur in yeast, encoded by the genes HMG1 and HMG2. Expression of both genes is regulated by oxygen. HMG1 is expressed to the greatest extent under highly aerobic conditions, whereas, HMG2 is strongly expressed under conditions of hypoxia. The transcription of both enzymes is activated by haem. The modest sterol concentrations synthesized by brewing yeast during fermentation probably result from the activity of

HMG2 alone. The relatively high sterol concentrations formed in brewing strains of *S. cerevisiae* growing under derepressed conditions probably require the activity of both HMG1 and HMG2.

Regulation of carbon flow up to squalene requires a partitioning of flux between the formation of sterols and the biosynthesis of other isoprenoids. This is accomplished by control of the activities of the enzymes in the early part of the sterol biosynthetic pathway and the expression of the genes encoding them. Squalene synthase is the first committed step in sterol synthesis. It appears that ergosterol and other late intermediates in the sterol pathway regulate the biosynthesis of ergosterol by feedback control mechanisms controlling the activities of enzymes earlier in the pathway.

Sterols are reportedly synthesized in the microsomal fraction of the endoplasmic reticulum (Schweizer, 1999). Other have asserted that a separate partitioned sterol biosynthetic pathway may occur in mitochondria (Casey *et al.*, 1992). To complicate matters further, sterol esters are located in cytosolic lipid granules. These membrane bound structures also contain triacylglycerols. In addition, sterol C-24 methyltransferase, a late enzyme of the sterol biosynthetic pathway is also found here as well as intermediates of sterol biosynthesis (Schweizer, 1999). The implication is that there may be more than one site of synthesis and in any case, an intracellular sterol transport system must exist. It is likely that under conditions of aerobic exponential growth, sterols are synthesized in the endoplasmic reticulum, transported to appropriate sites and incorporated into proliferating membranes. In stationary phase cells, where membrane proliferation has ceased, sterols are esterified by acyl-CoA: sterol acyltransferases and stored in lipid granules. If the conditions change such that growth recommences, sterol esters are transported to the sites of membrane growth and there they are cleaved by sterol ester hydrolases. The resultant free sterol may then be used for membrane synthesis.

In brewing fermentations the extent of sterol synthesis in yeast is modest compared to derepressed cells. Pitching yeast typically contains 0.1–0.2% of the cell dry weight as sterol. This increases to approximately 1% of the cell dry weight at the end of the aerobic phase of fermentation. The same yeast grown aerobically under derepressing conditions contains approximately 5% of the cell dry weight as sterol (Quain and Tubb, 1982).

12.8 Nitrogen metabolism

In wort, the major sources of nitrogenous nutrients are amino acids and ammonium ions. It would be supposed that amino acids might be incorporated directly into proteins and other macromolecules. However, in brewing strains of *S. cerevisiae*, growing fermentatively on wort, amino acids are catabolized (Jones and Pierce, 1970). By inference, amino acids that are required for the biosynthesis of other macromolecules must themselves be synthesized. Amino acids are usually degraded by long and convoluted pathways. These pathways provide essential precursors for other nitrogen-containing cellular constituents such as purines and pyrimidines. This anabolic requirement presumably explains the preference for degradation. The oxidative catabolism of amino acids ultimately removes the amino group. Providing the yeast is growing under derepressed and aerobic conditions the resultant carbon skeletons can be fed into oxidative energy-producing pathways or provide precursors for gluconeogenesis (Fig. 12.18). In this way nitrogen and sugar metabolism are coupled and coordinated.

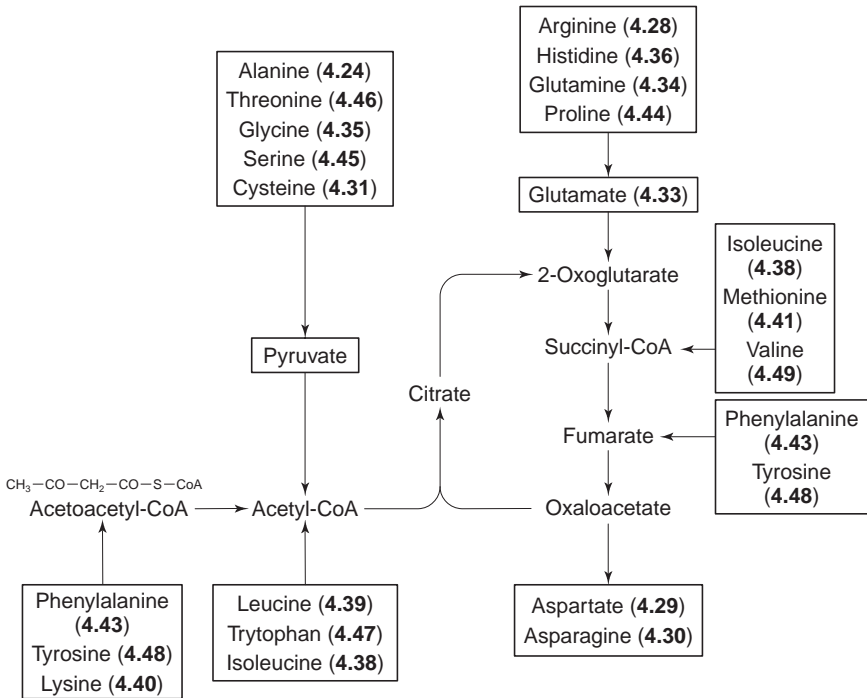

Fig. 12.18 Fate of carbon skeletons of amino acids following oxidative degradation. In some cases, as indicated, some amino acids contribute to the pools of more than one intermediate of the main sugar oxidative pathways. The numbers in parentheses indicate where the molecular structures may be found.

Alternatively, under fermentative conditions some of the products of amino acid catabolism may be released into the medium. As a result of the fermentative growth of yeast on wort, these may contribute to beer flavour. The carbon skeletons for amino acid synthesis may be derived from glycolysis. They may also be formed from the products of the degradation of other amino acids or ammonia may supply nitrogen for the amino groups. Thus, *S. cerevisiae* can utilize ammonia and most individual amino acids as sole sources of nitrogen. The biosynthetic pathways are not usually a simple reversal of those used for amino acid degradation. Key reactions in amino acid metabolism are transaminations where the α -amino group of an amino acid is transferred to the α -carbon atom of an α -keto acid. The latter is usually α -ketoglutaric acid. For example, the reaction shown below in which the amino group of L-aspartate is transferred to α -ketoglutarate to form L-glutamate.



These reactions are reversible and many amino acids participate in them. The deaminated amino acid is converted to the corresponding α -keto acid analogue. These α -keto acids are precursors of other metabolic by-products, which contribute to beer flavour, for example higher alcohols and esters (Section 12.10). In addition, they are themselves used to synthesize the corresponding amino acids, as required. The α -keto acid analogues of some amino acids are shown in Table 12.7.

Wort amino acids have been classified based on the relative contribution of their corresponding α -keto acid analogues to the development of a balanced spectrum of

Table 12.7 Amino acids and their corresponding α -keto acid analogues

Amino acid	α -keto acid analogue
Alanine	Pyruvic acid
Aspartate	Oxaloacetic acid
Glutamate	α -ketoglutaric acid
Isoleucine	α -keto- β -methylvaleric acid
Leucine	α -ketoisocaproic acid
Phenylalanine	Phenylpyruvic acid
Serine	Hydroxypyruvic acid
Tyrosine	Hydroxyphenylpyruvic acid
Valine	α -ketoisovaleric acid

Table 12.8 Classification of amino acids based on the essential nature of the corresponding α -keto acid analogue (from Jones and Pierce, 1970)

Class 1	Class 2	Class 3
Aspartate	Isoleucine	Lysine
Asparagine	Valine	Histidine
Glutamate	Phenylalanine	Arginine
Glutamine	Glycine	Leucine
Threonine	Alanine	
Serine	Tyrosine	
Methionine		
Proline		

flavour compounds (Jones and Pierce, 1970). The initial concentrations in wort of members of Class 1 (Table 12.8) were considered relatively unimportant since they could be either assimilated from wort or synthesised *de novo*. Thus, there is no shortage of intermediates and the provision of precursors for the synthesis of other essential products of metabolism. The initial concentration of Class 2 amino acids was considered crucial since in the later stages of fermentation synthesis of these from sugars was repressed. Consequently, the α -keto acid analogues derived from amino acid degradation became the major sources of these amino acid carbon skeletons. A shortage of the latter in late fermentation would be predicted to have large effects on the metabolism of related by-products and by inference beer quality. Class 3 amino acids were considered to be derived exclusively from wort. Deficiencies in these would be expected to restrict the synthesis of compounds derived from their α -keto acid analogues.

Glutamate and the ammonium ion are central to nitrogen metabolism since they link both catabolism and anabolism. The key enzymes are glutamine synthetase, glutamate synthase (GOGAT) and glutamate dehydrogenase. These catalyse the reactions shown following.

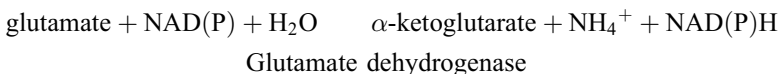
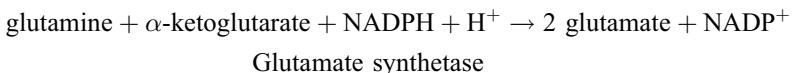
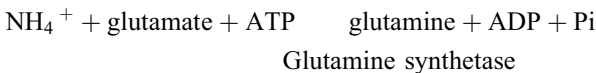

Glutamate and glutamine are the major sources of cellular nitrogen. Ammonium ions are converted to glutamate by glutamate dehydrogenase. Some of the glutamate is then converted to glutamine by glutamine synthetase. The latter enzyme is required for growth on any nitrogen source other than glutamine. Glutamine is an essential precursor for the biosynthesis of other amino acids as well as purines and pyrimidines. Yeasts have three glutamate dehydrogenases, one which is NAD^+ -linked (Gdh2). The other two require NADP^+ as cofactor, termed Gdh1 and Gdh3, respectively. The Gdh1 gene product has a catabolic function in the formation of glutamate, as described already. The Gdh2 enzyme is catabolic in nature and serves to produce ammonia and α -ketoglutarate in cells utilising glutamate. The role of the Gdh3 enzyme is not clear, although it has been speculated that it is involved in a nitrogen-sensing pathway (Wilkinson *et al.*, 1996).

Glutamate synthase performs the same function as the Gdh1, NADP^+ -dependent glutamate dehydrogenase in that it produces glutamate in conjunction with glutamine synthetase. Based on differences in kinetic properties it has been claimed that the GOGAT system is high affinity and low activity, whereas the Gdh1 system is the reverse. The enzyme systems described are regulated by the availability of nitrogen. Thus, Gdh1 and Gdh2 activities are inversely related depending on the availability of ammonia. Glutamine synthetase activity is induced when glutamate is the sole source of nitrogen but low in the presence of glutamine.

The regulation of amino acid metabolism during growth of *S. cerevisiae* on an undefined medium such as wort is complex. Intermediates and end-products of the pathways leading to and from individual amino acids exert control by feed-back mechanisms. In addition, there are global regulatory mechanisms. Starvation of any one of several amino acids induces many of the enzymes required for the biosynthesis of several amino acids. The phenomenon involves the increased transcription of more than 40 genes and it has been termed general amino acid control (Hinnebusch, 1997). With respect to the utilization of nitrogen sources, the presence of ammonia or glutamine causes the repression of the enzymes required for the catabolism of other amino acids. This process is termed nitrogen catabolite repression (Wiame *et al.*, 1985). Other metabolic controls may be overlaid on those solely driven by the nitrogen source. For example, in derepressed yeast, biosynthesis of serine occurs via glycine, derived from glyoxylate. However, in repressed yeast as is the case in fermentation, the glyoxylate cycle is not functional (12.5.6) and serine may be formed from glycolysis via 3-phosphoglycerate.

Glutamine, with other amino acids, provides nitrogen groups for the synthesis of purines, pyrimidines and N-acetylglucosamine. The latter is used in the synthesis of chitin, a structural component of yeast cell walls. Amino acids are the building blocks of proteins. A review of protein synthesis in yeast may be found in Tuite (1991). Yeast cells possess a number of enzymes responsible for the hydrolytic degradation of proteins, termed proteinases. These enzymes fulfil intracellular roles since *S. cerevisiae* does not utilize exogenous proteins. Some proteinases have a broad specificity and are involved in long-term protein turnover. Others have very specific substrates and have regulatory functions. The latter group catalyse reactions in which target proteins are modified by partial proteolysis such that they are reversibly activated or inactivated. These processes are distinct from the phenomenon of catabolite inactivation (Section 12.5.6).

The major site for proteolysis is the cell vacuole. Much of the regulation of both specific and non-specific proteolysis involves the sequestration of target proteins into vacuoles where they are exposed to proteinases. The majority of proteins are turned over very slowly. A small proportion is subject to rapid turnover. The latter group includes proteins required only under specific conditions, for example, cyclins.

The tasks of elimination of damaged proteins and rapid turnover in response to physiological changes is performed by the ubiquitin system. Ubiquitin is a protein that becomes attached via lysine residues in target proteins (Finley and Chau, 1991). Target proteins are attached to multiple molecules of ubiquitin in reactions catalysed by ubiquitin-protein ligase and ubiquitin-conjugating enzymes. The target protein-ubiquitin complex is recognized by a multi-enzyme proteolytic complex termed the proteasome. The latter catalyses the ATP-dependent degradation of the target protein to amino acids and peptides and releases ubiquitin so that it becomes available for further ubiquitination reactions.

12.9 Yeast stress responses

Yeast acidifies the medium when it is transferred from beer and suspended in water. This phenomenon is stimulated by the presence of exogenous glucose. The spontaneous and glucose-induced acidification of media is used as a method of assessing yeast physiological condition (Sigler and Hofer, 1991). The extrusion of protons is accompanied by the excretion of several organic species, including amino acids and nucleotides. The process has been termed shock excretion (Lewis and Phaff, 1964). It requires the presence of a fermentable sugar and presumably represents a stress-induced transient loss of membrane integrity.

As yeast progresses through the brewing cycle of storage, pitching, fermentation, cropping and storage, it is subject to a number of stresses. These include rapid temperature fluctuation, high barometric pressure, high osmotic pressure, low water activity, low pH, high ethanol concentration, transient aerobiosis and starvation. Yeasts have evolved various metabolic strategies to minimize the deleterious effects of many stresses (Sorger, 1991). The ability to withstand an applied stress can be constitutive, for example, the differing degrees of ethanol tolerance observed in individual strains of yeast (Section 12.5.9). Similarly, different yeast species can grow over different temperature ranges, indicating a spectrum of thermotolerance. For example, ale strains of *S. cerevisiae* can usually grow at higher temperatures than lager strains. Resistance to some stresses can be induced by non-lethal exposure to the stress in question. The biochemistry of these acquired responses is distinct for individual stresses, although often there is overlap. Thus, exposure to one stress commonly induces tolerance to a range of other stresses. Strategies for overcoming many stresses involve common cellular mechanisms.

The induced stress response requires a sensing system, a signal transduction pathway and expression of target genes. Exposure of yeast to elevated temperatures results in cellular dysfunction and ultimately death. These effects are caused via denaturation of proteins and membrane damage. When *S. cerevisiae* undergoes a temperature shift from 25°C to 37°C growth is temporarily arrested, trehalose accumulates and the synthesis of most proteins ceases. A small group of around 70 so-called heat shock proteins (hsps) are induced and produced in high concentrations. After a short period, growth recommences and synthesis of hsps continues at a reduced but higher level than non-heat shocked yeast. The heat-shocked yeast exhibits elevated thermotolerance.

The heat shock proteins include those responsible for trehalose biosynthesis. This is predictable, bearing in mind the membrane-stabilizing properties of this metabolite. The ubiquitin system is activated which facilitates the destruction of damaged proteins (12.8). Other hsps function as protein repair systems, ensuring that damaged molecules are refolded in their correct conformations. The mechanism by which the heat shock response

is generated has not been fully elucidated. The hsp genes are regulated by a heat shock transcription factor (hsf1P) that binds to the promoter region. The route by which the signal from heat shock to activation of the gene encoding hsf1P is not known. However, the protein can be phosphorylated and the extent of phosphorylation has been shown to correlate with transcriptional activation over a range of temperatures (Sorger, 1991).

Other stress responses are mediated by a specific stress response element (STRE) which has been identified in the promoter region of several stress responsive genes. These include genes encoding for enzymes involved in protection against a multitude of stresses including, oxidative, low pH, ethanol, weak organic acid and osmotic. Activation of these stress genes, via the STRE element, is in response to at least two signal transduction pathways. These are the Ras cAMP mediated cascade (Section 12.5.8) and the high osmolarity glycerol (HOG) pathway (Section 12.3.1). The common regulatory element within a number of apparently unconnected genes explains how individual stresses can induce overlapping responses.

The relevance of stress responses in yeast to brewing is unclear. The multitude of stresses to which yeast is subject during fermentation imply that a stress response will be exhibited throughout most if not all of the stages of brewing where yeast is present. It is reasonable to assume that a stress response makes the yeast more resistant to the stresses of the brewing process. This may be of particular importance in the case of high-gravity, high-volume fermentations.

12.10 Minor products of metabolism contributing to beer flavour

Both ethanol and carbon dioxide contribute to beer flavour. The latter has a ‘mouth tingle’ character, whereas ethanol imparts a ‘warming’ note to beers. In addition, fermentation of wort generates a multitude of other minor products of yeast metabolism, many of which contribute to beer flavour. The action of yeast on wort also serves to remove some components whose persistence in beer would be undesirable. The formation of a desirable mixture of flavour-active metabolites in beer is influenced by the choice of yeast strain and wort composition. One of the primary aims of fermentation management is to control the process to ensure that flavour metabolites are produced in consistent and desired quantities.

The principal flavour metabolites are aliphatic alcohols, aldehydes, organic and fatty acids and esters of alcohols and fatty acids. These are formed as by-products of the metabolism of sugars and amino acids. The relationships between these classes of metabolites are shown in Fig. 12.19. In addition a myriad of other products of yeast metabolism contribute to beer flavour. Many of these are excreted by yeast during fermentation. However, some are intracellular components that are released in the beer either by cell death and autolysis or via shock excretion (Section 12.9).

12.10.1 Organic and fatty acids

More than a hundred organic and fatty acids have been identified in yeast (Meilgard, 1975). Although some of these are derived from wort, many are produced as a result of yeast metabolism. Organic acid formation and excretion contributes to the reduction in pH that occurs during fermentation. They confer a ‘sour’ or ‘salty’ taste to beers. The most abundant organic acids found in beers and their typical concentrations are shown in Table 12.9. Organic acids are largely derived from the incomplete TCA cycle that occurs

Table 12.9 Beer organic acids (Coote and Kirsop, 1974; Whiting, 1976; Klopper *et al.*, 1986).

Organic acid	Typical concentration in beer (mg/l)
Acetic	10–50
Citric	100–150
Lactic	50–300
Malic	30–50
α -ketoglutaric	0–60
Pyruvic	100–200
Succinic	50–150

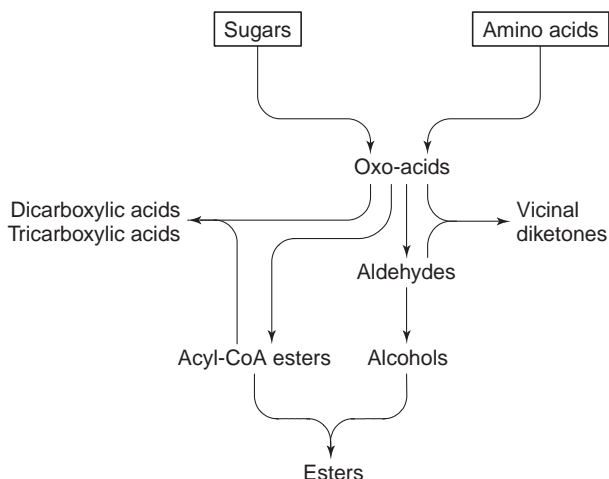
**Fig. 12.19** Relationships between the major classes of yeast-derived beer flavour compounds.

during anaerobic repressed growth of yeast (Section 12.5.8). In addition, some may derive from the catabolism of amino acids (Fig. 12.18). Lactate is derived from the reduction of pyruvate. The extracellular concentrations of some organic acids may both increase and decrease during fermentation. For example, it has been reported that pyruvate is excreted during early fermentation. At a later stage, this acid is taken up again and acetate is excreted (Coote and Kirsop, 1974). The maximum exogenous pyruvate concentration coincides with the point at which wort free amino nitrogen ceases to be assimilated possibly suggesting that the former is derived from the dissimilation of the latter (Fig. 12.1). The accumulation of exogenous pyruvate indicates that at least during part of fermentation, the rate of pyruvate dissimilation to ethanol is slower than the rate of formation of pyruvate. The extracellular formation of two oxo-acids, α -acetolactate and α -acetohydroxybutyrate is of special note since they are the precursors of the vicinal diketones, diacetyl and 2,3-pentanedione (Section 12.10.2).

Short and medium chain length fatty acids have unpleasant flavours and they inhibit beer foam formation. For these reasons, their presence in beer is undesirable. Generally, the medium chain-length fatty acids, principally C_{16} and C_{18} , of wort are replaced by shorter chain-length fatty acids (C_6 – C_{10}) in beer (Chen, 1980). These short chain-length fatty acids are powerful detergents and it seems probable that they are not excreted by yeast in a controlled process. Instead, it is likely that they exit cells as a result of plasma membrane leakage in response to ethanol stress (Section 12.5.9) or in extreme cases because of cell death and autolysis.

12.10.2 Carbonyl compounds

Carbonyl compounds are abundant in beers, where more than 200 have been detected (Berry and Watson, 1987). The concentrations of several aldehydes and the vicinal diketones are influenced by yeast metabolism during fermentation and subsequent conditioning. As a group, these generally make a negative contribution to beer flavour and aroma. An important requirement of fermentation management is to ensure that these compounds are reduced to acceptable concentrations.

Several aldehydes arise during wort production, others are formed as intermediates in the biosynthesis of higher alcohols from oxo-acids by yeast (Fig. 12.19). Exogenous aldehydes form adducts with sulphur dioxide and in this form they may not be available for enzymatic reduction. In this sense, the metabolism by yeast of aldehydes and sulphur containing compounds are intimately related. Several yeast reductases each with a differing spectrum of activity are involved in the elimination of aldehydes (Debourg *et al.*, 1993). These enzymes use either NADH or NADPH as hydrogen donor cofactors. The fermentative alcohol dehydrogenase (ADHI) is responsible for the reduction of pentanal and pentenal, and an aldose reductase reduces 3-methyl butanal and possibly pentanal. In addition, an aldoketoreductase with broad specificity has been detected (Laurent *et al.*, 1995).

Acetaldehyde is of special interest because of its role as the immediate precursor of ethanol. It has an unpleasant 'grassy' flavour and aroma. Acetaldehyde is formed during the early to mid stages of fermentation and thereafter it declines to a low level. In some circumstances, it can accumulate during fermentation in concentrations above the flavour threshold of 10–20 ppm. The principal causes of high acetaldehyde concentrations in beer are the use of poor quality pitching yeast, excessive wort oxygenation, unduly high fermentation temperature and excessive pitching rates (Geiger and Piendl, 1976).

S. cerevisiae possesses two acetaldehyde dehydrogenases. One is mitochondrial and requires NAD^+ or NADP^+ and K^+ for activity. The second enzyme is NADP^+ -linked, activated by Mg^{2+} and is located in the cytosol. It has been proposed that the mitochondrial enzyme is functional only during oxidative growth on ethanol (Jacobsen and Bernofsky, 1974). However, in a study of the activities of both acetaldehyde dehydrogenases during a high-gravity lager fermentation this supposition was apparently disproved (Fig. 12.20). Here it may be seen that the activity of ADH1 correlated closely with the formation of ethanol. Surprisingly, the cytosolic Mg^{2+} -dependent acetaldehyde dehydrogenase was active only during the early aerobic phase of fermentation. The K^+ -dependent mitochondrial acetaldehyde dehydrogenase was active throughout the whole of fermentation. Presumably, the latter enzyme would be instrumental in removing acetaldehyde during the later stages of fermentation. The reduction in acetaldehyde concentration characteristic of late fermentation would correlate with the concomitant increase in the concentration of extracellular acetate described in the previous section (Section 12.10.1).

The concentrations of two vicinal diketones (VDK), diacetyl (2,3-butanedione) and 2,3-pentanedione are of critical importance in the fermentation of lager beers. Both compounds have strong 'butterscotch' or 'toffee' aromas and tastes. Their presence in lagers at concentrations higher than their flavour thresholds of around 0.15 ppm and 0.9 ppm respectively, causes an objectionable flavour defect. The now accepted pathway is that vicinal diketones arise as by-products of the synthesis of valine and isoleucine (Fig. 12.21). A proportion of the pools of two acetoxy acids, α -acetolactate and α -acetoxybutyrate is excreted into the fermenting wort. There they undergo spontaneous oxidative decarboxylation to form diacetyl and 2,3-pentanedione. In late

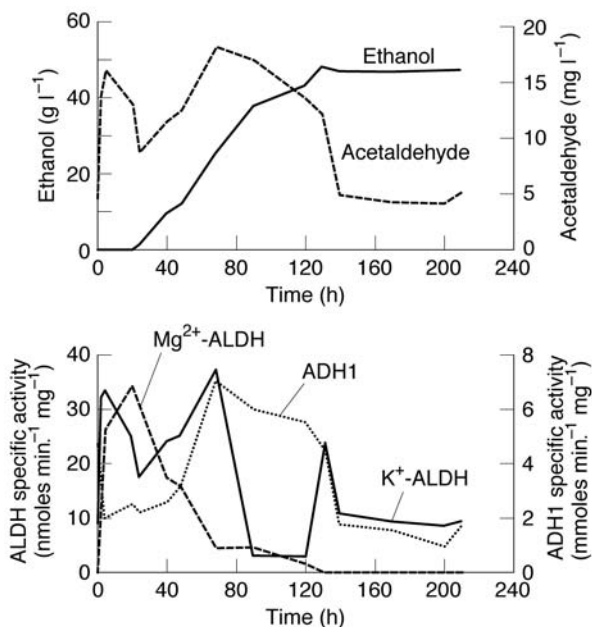

Fig. 12.20 Specific activities of Mg²⁺- and K⁺ aldehyde dehydrogenases (ALDH), alcohol dehydrogenase (ADH1) and changes in the concentrations of acetaldehyde and ethanol during a stirred 2.5 litre laboratory anaerobic fermentation using 12°P lager wort and a lager yeast strain (W. Tessier, unpublished data).

fermentation, or during the conditioning phase, vicinal diketones are re-assimilated by yeast and reduced to form acetoin and 2, 3-butanediol from diacetyl and 2, 3-pentanediol from 2, 3-pentanedione. The pattern of VDK formation and dissimilation during fermentation is shown in Fig. 12.1. The flavour thresholds of these reduced compounds are relatively high and at the concentrations that they are found in beer their presence is acceptable.

The wort FAN concentration and amino acid spectrum influence the formation of acetohydroxy acids. Nakatani *et al.*, (1984a, b) derived a relationship between total VDK concentration formed (T-VDK_{max}) and the minimum FAN concentration achieved during fermentation:

$$\text{T-VDK}_{\max} = \frac{0.161}{\text{FAN}_{\min} - 3.87} + 0.415$$

This relationship was taken to imply that wort composition and fermentation conditions should be manipulated to ensure that a controlled residual FAN concentration was left at the end of fermentation. This procedure would minimize the magnitude of the VDK peak. Similarly, worts with high concentrations of valine and isoleucine suppressed the formation of excessive VDK. Other than using worts with very high FAN concentrations, it is difficult to see how the spectrum of individual amino acids could be easily manipulated.

The rate-determining step in the formation of VDK is the spontaneous oxidative decarboxylation of the acetohydroxy acids. The reactions proceed relatively rapidly under aerobic conditions. Under anaerobic conditions, metal ions such as Cu²⁺, Al³⁺ and Fe³⁺ can act as alternative electron acceptors. The process is favoured by acidic conditions

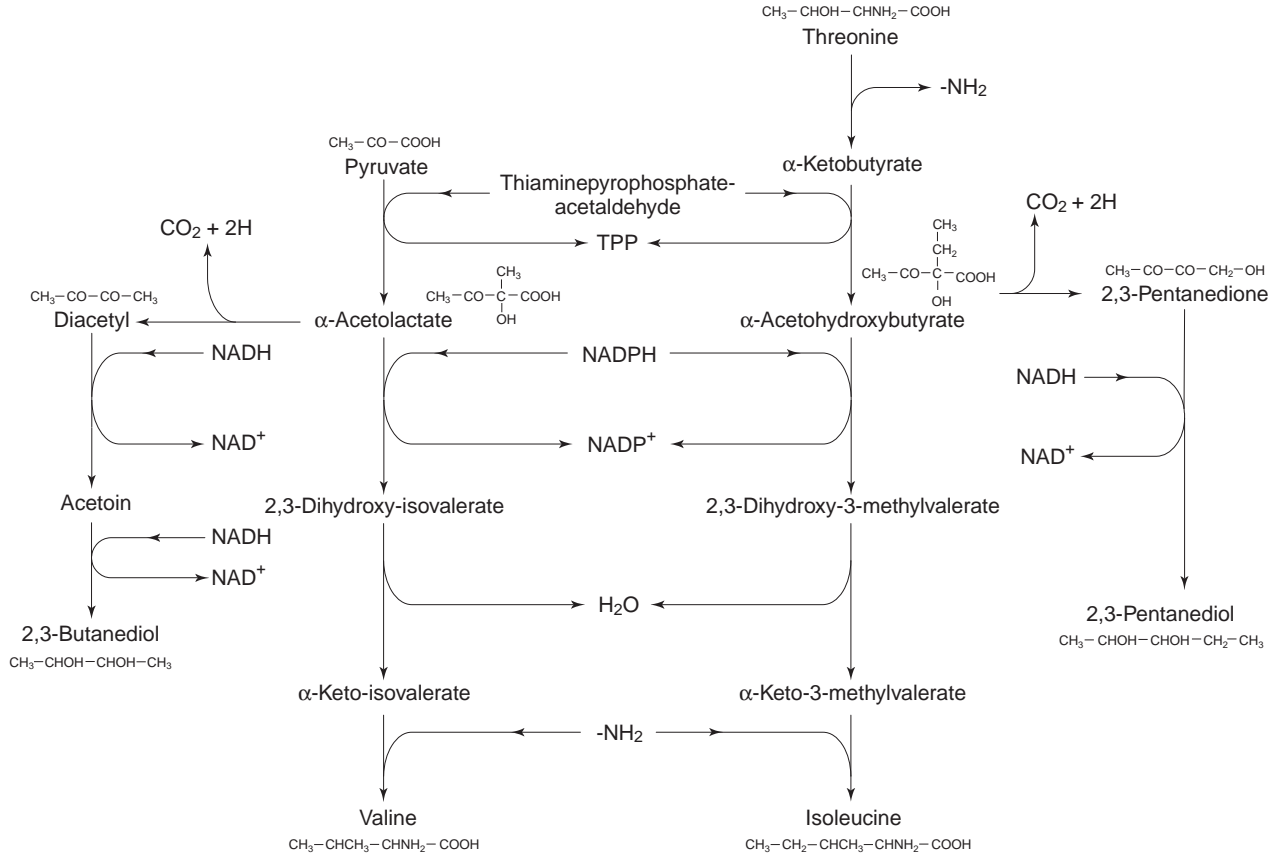

Fig. 12.21 Pathways for the formation and dissipation of the vicinal diketones, diacetyl and 2,3-pentanedione.

(Inoue *et al.*, 1968). Heating α -acetolactate at 70 °C under anaerobic conditions results in non-oxidative decarboxylation directly to acetoin. It has been suggested that this can also occur at moderate temperatures providing that sufficiently low redox conditions are maintained (Inoue *et al.*, 1991).

Reduction of VDK occurs in late fermentation or during conditioning and it requires the presence of viable yeast. Under most circumstances, yeast assimilates and reduces free diacetyl very rapidly. Consequently, the VDK which can be detected in wort during fermentation is mostly precursor acetohydroxy acid. Before VDK analyses can be performed on samples removed during fermentation, they must first be heated to ensure that all the acetohydroxy acid is converted to VDK. The majority of brewery VDK analyses represent the sum of free diacetyl and α -acetolactate. This is understandable since α -acetolactate is unstable and in the absence of yeast can be considered as 'potential diacetyl'. An essential aspect of fermentation management is to ensure that yeast is not separated from green beer before the pools of free VDK and precursor acetohydroxy acids are reduced to an acceptable concentration.

The physiological role fulfilled by VDK reduction during fermentation is not known, other than the possibility that it may represent another route for redox balancing (Section 12.2). The enzymology of VDK reduction is not well characterized. Several yeast reductases, both NAD⁺ and NADP⁺-requiring show activity *in vitro* towards diacetyl and 2,3-pentanedione, however, it is difficult to prove that they fulfil this role *in vivo*. Nevertheless, several reports of the occurrence of specific diacetyl reductases in *S. cerevisiae* have appeared in the literature (Louis-Eugene *et al.*, 1988; Legay *et al.*, 1989; Heidlas and Tressl, 1990; Scharwz and Hang, 1994; Murphy *et al.*, 1996).

In the last of these, it was shown that several brewing strains could be classified into two groups based on the differential patterns of thermolability of diacetyl reductases. Lager strains all contained a distinct heat stable acetoin reductase and alcohol dehydrogenases, which reduced diacetyl but showed no activity towards acetoin. Top-fermenting ale strains lacked the heat stable acetoin reductase but all contained another enzyme, which would reduce both acetoin and diacetyl.

The ability of yeast to reduce exogenous diacetyl declines during fermentation (Boulton and Box, 1999). This was demonstrated by adding exogenous free diacetyl to a series of similar stirred laboratory wort fermentations and monitoring the profiles of subsequent decline in concentration. The rates of uptake were slower, the later in fermentation that the diacetyl was added. At the end of fermentation when VDK concentrations were close to the minimum specification required before the application of cooling, yeast was most deficient in its ability to reduce VDK. This was taken to imply a possible decline in rates of diacetyl uptake because of lack of yeast membrane competence.

12.10.3 Higher alcohols

The formation of glycerol has been described (Section 12.3.1). Several alcohols, other than ethanol are formed in beer during fermentation (Engan, 1981). Higher alcohols achieve maximum concentrations in fermenting wort at a time roughly coincident with the point at which free amino nitrogen falls to a minimum concentration (Fig. 12.1). These are termed fusel alcohols because of their occurrence in fusel oil. This is a by-product of the production of ethanol from the fermentation of carbohydrates. Those that contribute to beer flavour include n-propanol, iso-butanol, 2-methylbutanol and 3-methylbutanol. It is considered that they impart a desirable warming character to beers

such that they intensify the flavour of ethanol. Higher alcohols are the precursors of the more flavour active esters.

Some higher alcohols may derive from the reduction of aldehydes and ketones present in wort. Higher alcohols are synthesized from 2-oxo acids. These are decarboxylated to form the corresponding aldehyde and then reduced to the alcohol. The alcohol dehydrogenases are NAD^+ -dependent. This has prompted the suggestion that higher alcohol biosynthesis represents another mechanism for cellular redox control (Quain and Duffield, 1985). The 2-oxo acids arise from carbohydrate metabolism via pyruvate and acetyl-CoA, the so-called anabolic route, which forms part of the biosynthetic pathways of amino acids. Alternatively, the 2-oxo acid derives from a transamination reaction during amino acid utilization. This is termed the catabolic or Ehrlich route to higher alcohol formation (Fig. 12.22).

The relative contribution of each biosynthetic route is determined by wort composition, the identity of the alcohol and the stage in fermentation. Thus, n-propanol is formed exclusively via the anabolic route since there is no corresponding amino acid. Predictably, where the wort has a high content of amino acids the catabolic route is favoured. Thus, under these conditions, amino acid synthesis is reduced via feed-back inhibition and the pool of 2-oxo acids is generated largely via amino acid catabolism. In the reverse situation where the supply of exogenous free amino acid is restricted, 2-oxo acids are formed via *de novo* synthesis from sugars and the anabolic route predominates. During fermentation of a typical all-malt wort, it has been reported that the yields of higher alcohols from each route are roughly similar (Schulthess and Ettliger, 1978). During the early part of fermentation when free amino acids are relatively plentiful, the catabolic biosynthetic route predominates. This is gradually reversed as the concentration of assimilable amino nitrogen declines.

Control of higher alcohol formation is achieved by the choice of an appropriate yeast strain and manipulation of fermentation conditions and wort composition. Several authors have reported that the choice of yeast strain has the biggest impact and that ale strains generally produce more higher alcohols than lager strains (Szlavko, 1974; Engan, 1978; Romano *et al.*, 1992). Manipulation of fermentation conditions and wort composition in ways that favour increased yeast growth also tend to elevate higher alcohol concentration in beer. For example, high wort FAN and high wort dissolved oxygen. Use of high fermentation temperatures also favours increased levels of higher alcohols, possibly due to alterations in membrane fluidity (Peddie, 1990). Higher alcohol formation can be lowered by application of top pressure during fermentation (Rice *et al.*, 1976).

12.10.4 Esters

Esters comprise the most important group of flavour-active compounds that are formed by yeast during fermentation. More than 100 esters have been detected in beers (Meilgard, 1975; Engan, 1981). Esters have fruity/solvent-like aromas and flavours. The most abundant is ethyl acetate, which accumulates to concentrations of 10–20 ppm. The concentrations of other esters are usually less than 1 ppm. The predominant route for formation is via the esterification of ethanol or a higher alcohol and a fatty acyl-CoA ester. Two enzymes are involved, an acyl-CoA synthetase and alcohol acyl transferase:

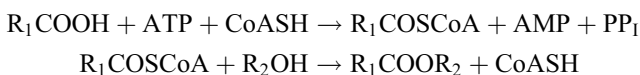

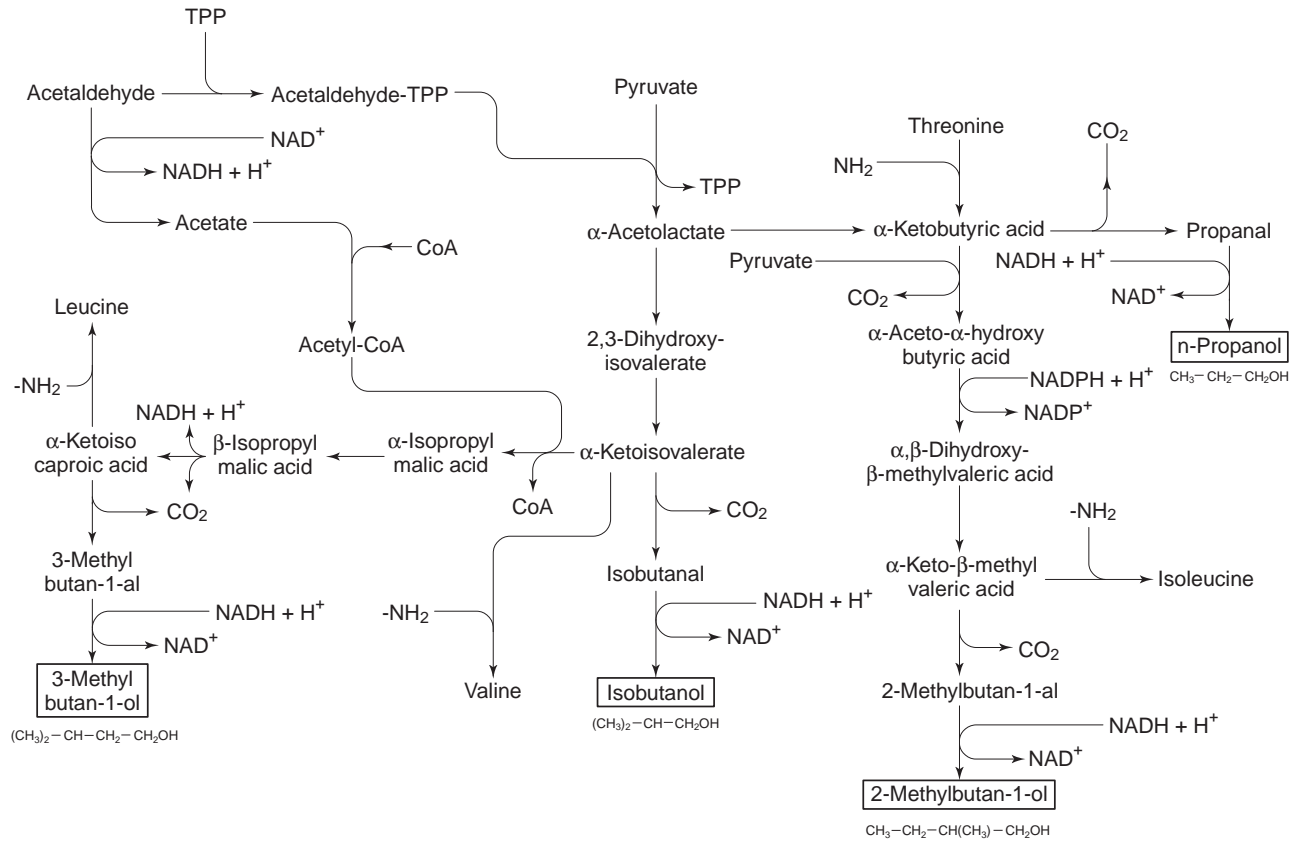

Fig. 12.22 Pathways for the formation of higher alcohols.

Acetyl-CoA and longer chain acyl-CoA esters can arise via the action of pyruvate dehydrogenase or acyl-CoA synthetase. During fermentation, the former route is unimportant (Section 12.5.5). The importance of the alcohol acyl transferase has been confirmed by the observation that mutants lacking the enzyme produce very low concentrations of esters (Lyness *et al.*, 1997).

The synthesis of esters requires the expenditure of metabolic energy suggesting that ester formation must fulfil an important metabolic role. It may be a mechanism for regulating the ratio of acyl-CoA to free CoA (Thurston *et al.*, 1981). Peak ester concentrations are reached after the formation of higher alcohols has ceased (Fig. 12.1). Rates of ester synthesis are maximal at the mid-point of fermentation coinciding with the cessation of lipid synthesis. Thus, when acetyl-CoA cannot be utilized by lipid synthesis, the formation of esters provides an alternative use for this substrate. Intermediates of lipid biosynthesis influence ester formation. Supplementation of worts with the unsaturated fatty acid, linoleic acid (50 mg l^{-1}) causes a dramatic decrease in ester formation (Thurston *et al.*, 1982). It was suggested that this effect was due to inhibition of alcohol acyltransferase by unsaturated fatty acids. This effect has been confirmed by others (Yoshioka and Hashimoto, 1982a, b, 1984) and led to the proposal that ester and lipid syntheses are inversely correlated. This is supported by the observation that increasing oxygen supply to wort tends to decrease ester synthesis. In this case, oxygen promotes the synthesis of unsaturated fatty acids, which in turn reduces the activity of alcohol acyltransferase.

It now appears that this effect is exerted at a more fundamental level (Malcorps *et al.*, 1991; Fuji *et al.*, 1997). These reports provided evidence that oxygen and linoleic acid caused repression of alcohol acyltransferase. In later studies (Dufour and Malcorps, 1994) the same groups demonstrated the existence of multiple isozymes of alcohol acyltransferase. These have different substrate specificity and not all are subject to repression by oxygen and unsaturated fatty acids.

The spectrum of esters produced during fermentation is controlled by the range and substrate specificity of the alcohol acyltransferases possessed by individual yeast strains. The concentrations of esters produced by given yeast strains can be modulated by factors that influence the availability of acyl-CoA esters and lipid biosynthesis. In particular, the provision of oxygen is crucial.

12.10.5 Sulphur-containing compounds

Sulphur-containing compounds in beer produced via yeast metabolic activity arise from organic sulphur-containing compounds such as some amino acids and vitamins. Alternatively, they may be formed from inorganic wort constituents such as sulphate. Sulphate is transported into yeast via a specific permease. Once in the cell it is reduced to sulphite in reactions that require ATP for energy. Thereafter, sulphite is reduced to sulphide via an NADP^+ -dependent reductase. The sulphide is then available for incorporation into a variety of sulphur-containing organic metabolites (Fig. 12.23). Under some circumstances appreciable levels of hydrogen sulphide accumulate in beer. The resultant sulphidic taste is an essential part of the flavour of some ales, for example Burton pale ales. Over-accumulation of hydrogen sulphide is undesirable. It can be controlled by ensuring that beers are exposed to copper, in the form of a piece of sacrificial pipe, which allows the formation of an insoluble sulphide. The pool size of S-adenosylmethionine has regulatory significance. Thus, its presence in the cell inhibits the transcription of all the genes, which encode the enzymes responsible for the uptake of sulphate, its reduction to sulphide and the synthesis of S-adenosylmethionine.

The presence of certain amino acids in wort modulates the metabolism of sulphur-containing compounds (Gyllang *et al.*, 1989). Supplementation of growth media with methionine increases the intracellular concentration of S-adenosylmethionine and causes the effects described already. Threonine in the medium reduces the activity of aspartokinase by feed-back inhibition (Fig. 12.23). This in turn reduces the pool sizes of O-acetylhomoserine and methionine. Hence, sulphite levels increase since the repressing effects of S-adenosylmethionine are relieved. Isoleucine also causes an increase in sulphite since its presence inhibits threonine utilization.

Sulphite forms adducts with carbonyl compounds. This prompted the suggestion that carbohydrate metabolism may influence sulphur metabolism (Korch *et al.*, 1991). These authors demonstrated a correlation between wort glucose concentration and sulphite levels in beer. At high glucose levels, there was a concomitant increase in the concentrations of pyruvate and acetaldehyde. These carbonyls formed addition compounds with sulphite, thereby depriving the methionine synthetic pathway of sulphite and resulting in derepression of the same.

The formation of sulphite during wort fermentation is influenced by the availability of amino acids (Dufour, 1991). During early fermentation, a plentiful supply of methionine and threonine causes repression of the sulphite synthetic pathway. In the phase of active fermentation, depletion of methionine and threonine derepresses the sulphite synthetic genes but sulphite does not accumulate because it is fully utilized for the synthesis of sulphur-containing amino acids. In mid to late fermentation yeast growth ceases, the amino acid pool is fully depleted and sulphite reductase activity declines to a low level. Under these circumstances, sulphite accumulation takes place.

Accumulation of sulphite in beers during fermentation is desirable since it may form adducts with potential staling carbonyls such as *trans*-2-nonenal. In this respect, there is a positive correlation between sulphite levels and beer flavour stability. Individual carbonyls have varying affinities for sulphite adduct formation. It has been claimed that the rate of sulphite formation regulates the proportion of carbonyls bound as adducts and those available for reduction by yeast (Dufour, 1991). It is essential for good flavour stability that sufficient sulphite is available to prevent the displacement of potential staling aldehydes from adducts by irreversible reactions with other beer components such as quinones and polyphenols.

The sulphur-containing compound dimethyl sulphide (DMS) is an important flavour compound. At high concentrations, it has a relatively objectionable taste and aroma of cooked sweet corn. At moderate concentrations (30–100 ppb) it is considered to be an essential component of lager beers. The precursor of DMS is S-methylmethionine (SMM) which is a component of malt (Chapter 4). During the conversion of green malt to finished malt, SMM is converted to DMS and another related metabolite dimethyl sulphoxide (DMSO). The conditions employed during malting influence the proportions of DMS and DMSO formed. A kilning temperature greater than 60°C is required for appreciable DMSO formation (Parsons *et al.*, 1977). SMM is converted to DMS by heat. The temperatures required for this conversion occur only during the malt and wort production stages of brewing. However, DMS is volatile and much is lost during mashing and wort boiling. DMSO is heat stable and persists unchanged through these stages.

At collection into fermenter, wort contains a mixture of SMM, DMS and DMSO. The proportions of each depend upon the raw materials used for wort production and the conditions employed in its manufacture. Further conversion of SMM to DMS during fermentation is precluded by the low temperature. The residual SMM is assimilated by yeast and converted to methionine. Thus, the concentration of DMS in beer is determined

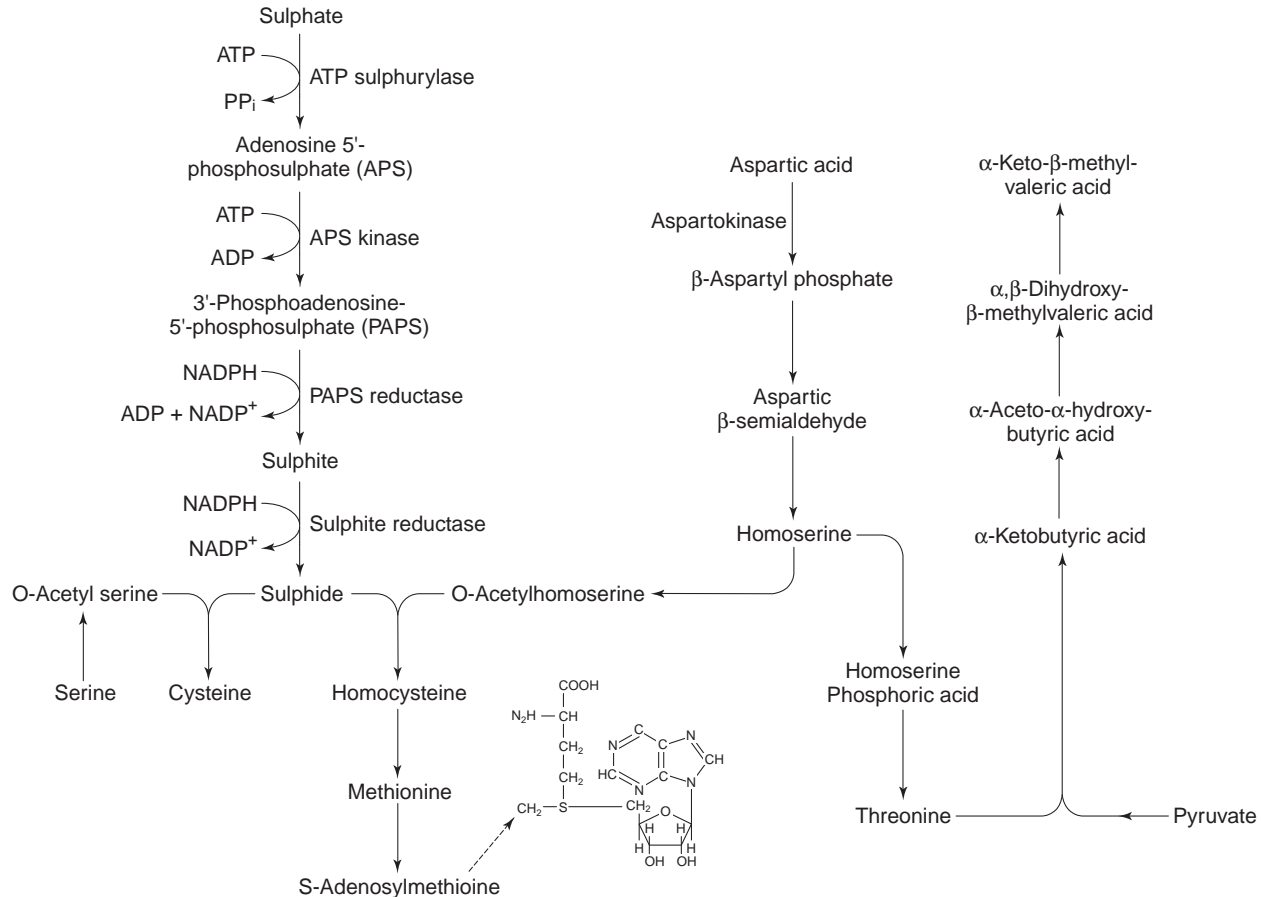

Fig. 12.23 Pathways for the assimilation of inorganic sulphur compounds and their incorporation into sulphur-containing amino acids.

largely during wort manufacture. However, yeast possesses a reductase activity, which allows the formation of DMS from DMSO (Gibson *et al.*, 1985). The enzyme is apparently subject to nitrogen catabolite repression and is most active in late fermentation when the wort FAN concentration is minimal.

12.11 References

- ALEXANDER, M. A. and JEFFRIES, T. W. (1990) *Enz. Microb. Technol.*, **12**, 2.
- ANDRE, B. (1995) *Yeast*, **11**, 1575.
- ANDREASON, A. A. and STIER, T. J. B. (1953a) *J. Cellul. Comparat. Physiol.*, **41**, 23.
- ANDREASON, A. A. and STIER, T. J. B. (1953b) *J. Cellul. Comparat. Physiol.*, **43**, 271.
- ARVINDEKAR, A. U. and PATIL, N. B. (2002) *Yeast*, **19**, 131.
- BARNETT, J. A. (1981) *Adv. Carbohydrate Chem. Biochem.* **39**, 347.
- BARNETT, J. A., PAYNE, R. W. and YARROW, D. (1990) *Yeasts, Characteristics and Identification*, 2nd edn, Cambridge University Press, Cambridge.
- BERRY, D. R. and WATSON, D. C. (1987). 'Production of organoleptic compounds'. In *Yeast Biotechnology*, D. R. Berry, I. Russell and G. G. Stewart eds, pp. 345–368. Allen & Unwin, London.
- BLACKWELL, K. J., SINGLETON, I. and TOBIN, J. M. (1995) *Appl. Microb. Biotechnol.*, **43**, 579.
- BOULTON, C. A. and QUAIN, D. E. (2001) *Brewing Yeast and Fermentation*, Blackwell Science, Oxford.
- BOULTON, C. A., BOX, W. G., QUAIN, D. E. and MOLZAHN, S. W. (1999) *Proc. 27th Cong. Eur. Brew. Conv., Cannes*, 687.
- BOURDOT, S. and KARST, F. (1995) *Gene*, **165**, 97.
- BRUINENBERG, P. M., VAN DIJKEN, J. P. and SCHEFFERS, W. A. (1983) *J. Gen. Microbiol.*, **129**, 953.
- BUSTERIA, J. R. and LAGUNAS, R. (1986) *J. Gen. Microbiol.*, **132**, 379.
- CARTWRIGHT, C. P., ROSE, A. H., CALDERBANK, J. and KEENAN, M. H. (1989) In *The Yeasts*, Vol. 3 (2nd edn) A. H. Rose and J. S. Harrison eds, pp. 5–56, Academic Press, London.
- CASEY, W. M., KEESLER, G. A. and PARKS, L. W. (1992) *J. Bacteriol.*, **174**, 7283.
- CHEN, E. C-H. (1980) *J. Am. Soc. Brew. Chem.*, **38**, 148.
- CIESSAROVA, V. J., SMOGROVICOVA, D. and DOMENY, Z. (1996) *Folia Microbiologica*, **41**, 485.
- CLARKSON, S. P., LARGE, P. J., BOULTON, C. A. and BAMFORTH, C. W. (1991) *Yeast*, **7**, 91.
- COOTE, N. and KIRSOP, B. H. (1974) *J. Inst. Brew.*, **80**, 474.
- COSTA, V., REISS, E., QUINTANILHA, A. and MORADAS-FERREIRA, P. (1993) *Archiv. Biochem. Biophys.*, **300**, 608.
- CRABTREE, H. G. C. (1929) *Biochem. J.*, **23**, 536.
- CROWE, J. H., CROWE, L. M. and CHAPMAN, D. (1984) *Science*, **223**, 701.
- CRUMPLEN, R., D'AMORE, T., SLAUGHTER, C. and RUSSELL, I. (1993) *Proc. 24th Cong. Eur. Brew. Conv., Oslo*, 267.
- CRUMPLEN, R. M., SLAUGHTER, J. C. and STEWART, G. G. (1996) *Lett. Appl. Microbiol.*, **23**, 448.
- D'AMORE, T., PANCHAL, C. J. and STEWART, G. G. (1988) *Appl. Environ. Microbiol.*, **54**, 110.
- D'AMORE, T., PANCHAL, C. J., RUSSELL, I. and STEWART, G. G. (1990) *Crit. Rev. Biotechnol.*, **9**, 287.
- DAVELOOSE, M. (1987) *MBAA Tech. Quart.*, **24**, 109.
- DAWES, I. W. (1999) In *The Metabolism and Molecular Physiology of Saccharomyces cerevisiae* J. R. Richardson and M. Schweizer eds, pp. 277–326. Taylor & Francis, London.
- DE NOBEL, J. G., KLIS, F. M., RAM, A., VAN UNEN, H., PRIEM, J., MUNNIK, T. and VAN DEN ENDE, H. (1991) *Yeast*, **7**, 589.
- DE WINDE, J. H. and GRIVELL, L. A. (1993) *Prog. Nucleic Acid Res. and Molec. Biol.*, **46**, 51.
- DEBOURG, A., LAURENT, M., DUPIRE, S. and MASSCHELEIN, C. A. (1993) *Proc. 24th Cong. Eur. Brew. Conv., Oslo*, 437.
- DOES, A. L. and BISSON, L. F. (1989) *J. Bacteriol.*, **171**, 1303.
- DOMBEK, K. M. and INGRAM, L. O. (1986) *Appl. Environ. Microbiol.*, **52**, 975.
- DUFOUR, J.-P. (1991) *Proc. 23rd Cong. Eur. Brew., Conv. Lisbon*, 209.
- DUFOUR, J.-P. and MALCORPS, P. (1994) *Proc. 4th Aviemore Conf. Malting, Brew. and Dist.*, I. Campbell ed., pp. 137–145, IOB, London.
- ELEUTHERIO, E. C. A., DE ARUJO, P. S. and PANEK, A. D. (1993) *Biochim. et Biophys. Acta*, **1156**, 263.
- ENGAN, S. (1978) *Proc. 18th Cong. Eur. Brew. Conv., Zoeterwoede*, 28.
- ENGAN, S. (1981) 'Beer composition: volatile substances'. In *Brewing Science*, (J. R. A. Pollock, ed.), vol. 2, pp. 98–105. Academic Press, London.
- FAERGEMAN, N. J., DIRUSSO, C. C., ELBERGER, A., KNUDSON, J. and BLACK, P. N. (1997) *J. Biol. Chem.*, **272**, 8531.
- FELS, S., RECKELBUS, B. and GOSSELIN, Y. (1999) *Proc. 7th IOB Conv., Africa Section, Nairobi*, 147.
- FINLEY, D. and CHAU, V. (1991) *Ann. Rev. Cell Biol.*, **7**, 25.

- FRAENKEL, D. G. (1982) 'Carbohydrate metabolism'. *The Molecular Biology of the Yeast, Saccharomyces cerevisiae*, Vol. 2, *Metabolism and Biosynthesis*, pp. 1–37. J. N. Strathern, E. W. Jones and J. R. Broach eds, Cold Spring Harbor Laboratory.
- FRANCOIS, J., BLAZQUEZ, M. A., ARINO, J. and GANCEDO, C. (1997) *Yeast Sugar Metabolism, Biochemistry, Genetics, Biotechnology and Applications*, F. K. Zimmermann and K.-D. Entian eds, pp. 285–311, Technomic Publishing Co., Lancaster, USA.
- FRIDOVICH, I. (1986) *Archiv. Biochem. Biophys.*, **247**, 1.
- FUJI, T., YOSHIMOTO, H., NAGASAWA, N. and TAMAI, T. (1996) *J. Ferment. Bioeng.*, **81**, 538.
- FUJI, T., KOBAYASHI, O., YOSHIMOTO, H., FURUKAWA, S. and TAMAI, Y. (1997) *Appl. Environ. Microbiol.*, **63**, 910.
- GAMO, F. J., MORENO, E. and LAGUNAS, R. (1995) *Yeast*, **11**, 1393.
- GANCEDO, J. M. (1992) *Eur. J. Biochem.*, **206**, 297.
- GANCEDO, J. M. and GANCEDO, C. (1997) 'Gluconeogenesis and catabolite inactivation'. *Yeast Sugar Metabolism, Biochemistry, Genetics, Biotechnology and Applications*, F. K. Zimmermann & K.-D. Entian eds, pp. 359–378, Technomic Publishing Co., Lancaster, USA.
- GANCEDO, C. and SERRANO, R. (1989) 'Energy-yielding metabolism'. *The Yeasts*, vol. 3, 2nd edn, A. H. Rose and J. S. Harrison eds, pp. 205–259, Academic Press, London.
- GEIGER, E. and PIENDL, A. (1976) *MBAA Tech. Quart.*, **13**, 51.
- GIBSON, R. M., LARGE, P. J. and BAMFORTH, C. W. (1985) *J. Inst. Brew.*, **91**, 397.
- GONZALES, C. I. and MARTIN, C. E. (1996) *J. Biol. Chem.*, **271**, 25801.
- GRENOU, M. (1992) 'Amino acid transporters: structure, function and regulation'. *Molecular Aspects of Transport Proteins*. J. De Pont, ed., pp. 219–245, Elsevier Science Publishers, London.
- GUERIN, B. (1991) 'Mitochondria'. *The Yeasts*, Vol. 4, A. H. Rose and J. S. Harrison, eds, pp. 541–600, Academic Press, London.
- GUSTIN, M. C., MARTINAC, B., SAIMI, Y., CUTHBERTSON, M. R. and KUNG, C. (1986) *Science*, **233**, 1995.
- GYLLANG, H., WINGE, M. and KORCH, C. (1989) *Proc. 23rd Cong. Eur. Brew. Conv. Zurich*, 347.
- HEIDLAS, J. and TRESSL, R. (1990) *Eur. J. Biochem.*, **188**, 165.
- HINNEBUSCH, A. G. (1997) *CRC, Crit. Rev. Biochem.*, **21**, 277.
- HISADA, K., SUZUKI, Y. and TAMURA, K. (2002) *Trends in High Pressure Biosci. and Biotechnol.*, **5**, 325.
- HORAK, J. (1986) *Biochim. Biophys. Acta*, **864**, 223.
- HORAK, J. (1997) *Biochim. Biophys. Acta*, **1331**, 41.
- INGLEDEW, W. M. and PATTERSON, C. A. (1999) *J. Amer. Soc. Brew. Chem.*, **57**, 9.
- INOUE, T., MASAYAMA, K., YAMAMOTO, Y. and OKADA, K. (1968) *Reports of the Res. Lab. Kirin Brew. Co.*, **11**, 9.
- INOUE, T., MURAYAMA, H., KAJINO, K., KAMIYA, T., MITSUI, T. and MAWATARI, M. (1991) *Proc. 23rd Cong. Eur. Brew. Conv., Lisbon*, 369.
- JACOBSEN, M. K. and BERNOFSKY, C. (1974) *Biochim. Biophys. Acta*, **350**, 277.
- JACOBSEN, M. and THORNE, R. S. W. (1980) *J. Inst. Brew.*, **86**, 284.
- JAZWINSKI, S. M. (1999) *Expt. Gerontol.*, **34**, 1.
- JONES, R. P. (1987) *Proc. Biochem.*, **22**, 129.
- JONES, R. P. (1989) *Enz. Microb. Technol.*, **9**, 334.
- JONES, R. P. and GADD, G. M. (1990) *Enz. Microb. Technol.*, **12**, 402.
- JONES, R. P. and GREENFIELD, P. F. (1984) *Proc. Biochem.*, **April**, 48.
- JONES, R. P. and GREENFIELD, P. F. (1987) *Enz. Microb. Technol.*, **9**, 334.
- JONES, M. and PIERCE, J. S. (1970) *Proc. 25th Cong. Eur., Brew. Conv., Interlaken*, 151.
- KIRSOP, B. H. (1974) *J. Inst. Brew.*, **80**, 252.
- KIRSOP, B. H. (1982) *Topics in Enzyme and Ferment. Biochem.*, **6**, 79.
- KLOPPER, W. J., ANGELINO, S. A. G. F., TUNING, B. and VERMEIRE, H.-A. (1986) *J. Inst. Brew.*, **92**, 311.
- KOHNO, Y., EGAWA, Y., ITOH, S., NAGAOKA, S., TAKAHASHI, M. and MUKAI, K. (1995) *Biochim. Biophys. Acta*, **1256**, 52.
- KOLAROV, J., KOLAROV, N. and NELSON, N. (1990) *J. Biol. Chem.*, **265**, 12711.
- KORCH, C., MOUNTAIN, H. A., GYLLANG, H., WINGE, M. and BREHMER, P. (1991) *Proc. 23rd Cong. Eur. Brew. Conv., Lisbon*, 201–208.
- KREGER-VAN RIJ, N. J. W. (1984) *The Yeasts, a Taxonomic Study* (3rd edn) Elsevier, Biomedical Press, Amsterdam.
- KREMS, B., CHARIZANIS, C. and ENTIAN, K.-D. (1995) *Curr. Genetics*, **27**, 427.
- KRUCKENBERG, A. L. (1996) *Arch. Microbiol.*, **166**, 283.
- KURTZMAN, C. P. and FELL, J. W. (1998) *The Yeasts, A Taxonomic Study* (4th edn) C. P. Kurtzman and J. W. Fell, eds, Elsevier, Amsterdam.
- LAGUNAS, R. (1993) *FEMS Microbiol. Rev.*, **104**, 229.
- LAURENT, M., GELDORF, B., VAN NEDERVELDE, L., DUPIRE, S. and DEBOURG, A. (1995) *Proc. 25th Cong. Eur. Brew. Conv., Brussels*, 337.
- LEGAY, O., RATOMAHENINA, R. and GALZY, P. (1989) *Agric. Biol. Chem.*, **53**, 531.
- LEWIS, M. J. and PHAFF, H. J. (1964) *J. Bacteriol.*, **87**, 1389.
- LILLIE, S. H. and PRINGLE, J. R. (1980) *J. Bacteriol.*, **143**, 1384.

- LOUIS-EUGENE, S., RATOMAHHENINA, R. and GALZY, P. (1988) *Folia Microbiologica*, **33**, 38.
- LUYTEN, K., ALBERTYN, J., SKIBBE, W., PRIOR, B. A., RAMOS, J., THEVELEIN, J. M. and HOHMANN, S. (1995) *EMBO J.*, **14**, 1360.
- LYNESS, C. A., STEELE, G. M. and STEWART, G. G. (1997) *J. Amer. Soc. Brew. Chem.*, **55**, 141.
- MAEDA, T., WUGLER-MURPHY, S. M. and SATO, H. (1994) *Nature*, **369**, 242.
- MAGER, W. H. and VARELA, J. C. S. (1993) *Molec. Microbiol.*, **10**, 253.
- MAJARA, M., O'CONNOR-COX, E. S. C. and AXCELL, B. C. (1996a) *J. Amer. Soc. Brew. Chem.*, **54**, 149.
- MAJARA, M., O'CONNOR-COX, E. S. C. and AXCELL, B. C. (1996b) *J. Amer. Soc. Brew. Chem.*, **54**, 221.
- MALCORPS, P., CHEVAL, J. M., JAMIL, S. and DUFOUR, J.-P. (1991) *J. Amer. Soc. Brew. Chem.*, **49**, 47.
- MANSURE, J. J. C., PANEK, A. D., CROWE, L. M. and CROWE, J. H. (1994) *Biochim. Biophys. Acta*, **1191**, 309.
- MARDER, R., BECKER, J. M. and NAIDER, F. (1977) *J. Bacteriol.*, **131**, 906.
- MARECHAL, P. A., MARTINEZ DE MARANON, I., MOLIN, P. and GERVAIS, P. (1995) *Internat. J. Food Microbiol.*, **28**, 277.
- MEILGARD, M. (1975) *MBAA Tech. Quart.*, **12**, 151.
- MISHRA, P. (1993) 'Tolerance of fungi to ethanol'. In *Stress Tolerance of Fungi* D. H. Jennings, ed, pp. 189–208, Marcel Dekker, New York.
- MITCHELL, P. (1979) *Science*, **206**, 1148.
- MURPHY, C., LARGE, P. J., WADFORTH, C., DACK, S. J. AND BOULTON, C. A. (1996) *Biotechnol. Appl. Biochem.*, **23**, 19.
- NAGODAWITHANA, T. W. and STEINKRAUS, K. H. (1976) *Appl. Environ. Microbiol.*, **31**, 158.
- NAKATANI, K., TAKAHASHI, T., NAGAMI, K. and KUMADA, J. (1984a) *MBAA Tech. Quart.*, **21**, 73.
- NAKATANI, K., TAKAHASHI, T., NAGAMI, K. and KUMADA, J. (1984b) *MBAA Tech. Quart.*, **21**, 175.
- O'CONNOR-COX, E. S. C., LODOLO, E. J. and AXCELL, B. C. (1993) *J. Amer. Soc. Brew. Chem.*, **51**, 97.
- OLIVERA, H., GONZALEZ, A. and PENA, A. (1993) *Yeast*, **9**, 1065.
- OURA, E., HAARASILTA, S. and LONDESBOROUGH, J. (1980) *J. Gen. Microbiol.*, **118**, 51.
- OZCAN, S. and JOHNSTON, M. (1999) *Microbiol. Molec. Biol. Rev.*, **63**, 554.
- OZCAN, S., VALLIER, L. G., FLICK, J. S., CARLSON, M. and JOHNSTON, M. (1997) *Yeast*, **13**, 127.
- PARKS, L. W. (1978) *CRC Crit. Rev. Microbiol.*, **6**, 301.
- PARKS, L. W. and CASEY, W. M. (1995) *Ann. Rev. Microbiol.*, **49**, 95.
- PARSONS, R. P., WAINWRIGHT, T. and WHITE, F. H. (1977) *Proc. 16th Conv. Eur. Brew. Conv., Amsterdam*, 115.
- PEDDIE, H. A. B. (1990) *J. Inst. Brew.*, **96**, 327.
- PHAFF, H. J., MILLER, M. W. and MRAK, E. M. (1978) *The Life of Yeasts* (2nd edn) Harvard University Press, USA.
- PIERCE, J. S. (1987) *J. Inst. Brew.*, **93**, 378.
- POSTMA, E., VERDUYN, C. SCHEFFERS, W. A. and VAN DIJKEN, P. J. (1989) *Appl. Environ. Microbiol.*, **55**, 468.
- PRATT-MARSHALL, P. L., BREY, S. E., DE COSTA, S. D., BRYCE, J. H. and STEWART, G. G. (2002) *Brewers' Guardian*, **131**, 22.
- QUAIN, D. E. and DUFFIELD, M. L. (1985) *Proc. 20th Cong. Eur. Brew. Cong., Helsinki*, 307.
- QUAIN, D. E. and TUBB, R. S. (1982) *MBAA Tech. Quart.*, **19**, 29.
- RAPOPORT, A. I., KHRUSTALEVA, G. M., CHAMMANIS, G. Y. and BEKER, M. E. (1995) *Mikrobiologiya*, **64**, 229.
- RATRAY, J. B. M. (1988) 'Yeasts' In *Microbial Lipids*, C. Ratledge and S. G. Wilkinson eds, vol. 1, pp. 555–697, Academic Press, London.
- REES, E. M. R. and STEWART, G. G. (1997) *J. Inst. Brew.*, **103**, 287.
- RICE, J. F., CHICOYE, E., HELBERT, J. R. and GARVER, J. (1976) *J. Amer. Soc. Brew. Chem.*, **35**, 35.
- ROMANO, P., SUZZI, G., COMI, G. and ZIRONI, R. (1992) *J. Appl. Bacteriol.*, **73**, 126.
- ROSE, A. H. (1987) 'Responses to the chemical environment'. In *The Yeasts*, 2nd edn, A. H. Rose and J. S. Harrison, eds, Vol. 2, pp. 5–40. Academic Press, London.
- ROSE, A. H. and HARRISON, J. S. (1995) 'Responses to the chemical environment.' In *The Yeasts* (2nd edn) Vol. 2, Academic Press, London.
- RYDER, D. S., MURRAY, J. P. and STEWART, M. (1978) *MBAA Tech. Quart.*, **15**, 9.
- SCHNEIDER, R., BRORS, B., BURGER, F., CAMRATH, S. and WEISS, H. (1997) *Curr. Genetics*, **32**, 384.
- SCHULTHESS, D. and ETLINGER, L. (1978) *J. Inst. Brew.*, **84**, 240.
- SCHWARZ, J. G. and HANG, Y. D. (1994) *Lett. Appl. Microbiol.*, **18**, 272.
- SCHWEIZER, M. (1999) 'Lipids and membranes'. In *The Metabolism and Molecular Physiology of Saccharomyces cerevisiae*, J. R. Richardson and M. Schweizer eds, pp. 79–155. Taylor & Francis, London.
- SERRANO, R. (1989) *Ann. Rev. Plant Physiol. and Plant Molec. Biol.*, **40**, 61.
- SIGLER, K. and HOFER, M. (1991) *Biochim. Biophys. Acta*, **1071**, 375.
- SINGH, K. S. and NORTON, R. S. (1991) *Arch. Microbiol.*, **156**, 38.
- SORGER, P. K. (1991) *Cell*, **65**, 363.
- SOUMALAINEN, H. and OURA, E. 'Yeast nutrition and solute uptake'. (1971) In *The Yeasts*, A. H. Rose and J. S. Harrison, eds, Vol. 2, pp. 3–74. Academic Press, London.

- STANLEY, G. A. and PAMENT, N. B. (1993) *Biotechnol. Bioeng.*, **42**, 24.
- STARK, M. J. (1999) 'Protein phosphorylation and dephosphorylation' In *The Metabolism and Molecular Physiology of Saccharomyces cerevisiae* J. R. Richardson and M. Schweizer eds, pp.209–275. Taylor & Francis, London.
- STEWART, G. G., ZHENG, X. and RUSSELL, I. (1995) *Proc. 25th Cong. of the Eur. Brew. Conv., Brussels*, 403.
- SZLAVKO, C. M. (1974) *J. Inst. Brew.*, **80**, 534.
- THEVELEIN, J. M. (1994) *Yeast*, **10**, 1753.
- THEVELEIN, J. M. and HOHMANN, S. (1995) *Trends in Biochem. Sci.*, **20**, 3.
- THURSTON, P. A., QUAIN, D. E. and TUBB, R. S. (1981) *Proc. 18th Cong. Eur. Brew. Conv., Copenhagen*, 197.
- THURSTON, P. A., QUAIN, D. E. and TUBB, R. S. (1982) *J. Inst. Brew.*, **88**, 90.
- TUITE, M. F. (1991) 'Protein synthesis'. In *The Yeasts*, Vol. 3, 2nd edn, A. H. Rose and J. S. Harrison eds, pp. 161–204, Academic Press, London.
- TZAGOLOFF, A. and DIECKMANN, C. I. (1990) *Microbiol. Rev.*, **54**, 211.
- VAN DER REST, M., KAMMINGA, A. H., NAKANO, A., ANRAKU, Y. and POOLMAN, W. N. (1995) *Microbiol. Rev.*, **59**, 304.
- VAN ZYL, P. J., KILIAN, S. G. and PRIOR, B. A. (1990) *Appl. Microbiol. Biotechnol.*, **34**, 231.
- VISSER, W., SCHEFFERS, W. A., BATENBURG VAN DER VEGTE, W. and VAN DIJKEN, J. P. (1990) *Appl. Environ. Microbiol.*, **56**, 3785.
- WALKER, G. M. (1998) *Yeast Physiology and Biotechnology*, John Wiley & Sons, West Sussex, UK.
- WALKER, G. M., BIRCH, R. M., CHANDRASENA, G. and MAYNARD, A. I. (1996) *J. Amer. Soc. Brew. Chem.*, **54**, 13.
- WANG, S. S. and BRANDRISS, M. C. (1987) *Molec. Cell. Biochem.*, **7**, 4431.
- WARBURG, O. (1926) *Biochemische Zeitschrift*, **172**, 432.
- WHITING, G. C. (1976) *J. Inst. Brew.*, **82**, 84.
- WIAME, J.-M., GRENSON, M. and ARST, H. N. (1985) *Adv. Microb. Physiol.*, **26**, 1.
- WILKINSON, B. M., JAMES, C. M. and WALMSLEY, R. M. (1996) *Microbiology*, **142**, 1667.
- YOSHIOKA, K. and HASHIMOTO, N. (1982a) *Reports of Res. Lab. Kirin Brewing Co.*, **25**, 1.
- YOSHIOKA, K. and HASHIMOTO, N. (1982b) *Reports of Res. Lab. Kirin Brewing Co.*, **25**, 7.
- YOSHIOKA, K. and HASHIMOTO, N. (1984) *Reports of Res. Lab. Kirin Brewing Co.*, **27**, 23.
- YOUATT, J. (1993) *Crit. Rev. Microbiol.*, **19**, 83.
- ZITOMER, R. S. and LOWRY, C. V. (1992) *Microbiol. Rev.*, **56**, 1.

13

Yeast growth

13.1 Introduction

Yeast growth is defined as the coordinated assimilation of nutrients from the medium and subsequent metabolism to yield new biomass. New biomass is generated by increase in size of individual cells and by cellular proliferation. The biochemical reactions which underpin anabolic metabolism and which result in the synthesis of cellular macromolecules are outlined in Chapter 12. The biology of the yeast cell cycle is described in Chapter 11. In this chapter the dynamics of yeast populations with respect to the influence of cultural conditions are discussed.

All organisms must proliferate and in so doing promulgate their genotypes via their progeny. The formation of beer during the fermentation of wort is a by-product of yeast growth. The aim of the brewer is to manipulate conditions to control the growth and metabolism of yeast to produce a desired product. In practice, this involves exerting appropriate controls to influence the balance between the yields of biomass and metabolites. With regard to batch fermentation, maximum fermentation efficiency is achieved by minimizing the proportion of wort nutrients used for biomass generation and thereby maximizing the yield of beer. With regard to fermenter cycle times, a secondary aim is to ensure minimum residence times. Thus, fermentation management requires control of both yeast proliferation and growth rate. However, both of these aims have to be tempered by the need to employ conditions that yield beer of the desired quality.

Most brewers ensure the trueness-to-type of production yeast strains by the periodic introduction of a new culture derived from a laboratory stock. Sufficient yeast for brewing is obtained by performing a series of fermentations of ever-increasing volume. Since the aim is to generate yeast mass and not beer, the conditions are manipulated to favour growth. Conversely, in recent years there has been a renaissance of interest in continuous fermentation processes, especially using immobilized yeast. These may be for primary fermentation or perhaps more commonly for a secondary conditioning process such as continuous diacetyl removal. The aim of all of these processes is to minimize cell proliferation and use the yeast as a biocatalyst (Boulton and Quain, 2001).

Most modern brewers use pure cultures of a single or defined mixture of yeast strains. This requires the resources of a laboratory, where stock cultures must be maintained. The appropriate apparatus must be available for growing pure cultures to produce sufficient yeast to inoculate a brewery propagation vessel. Methods are required to identify individual strains to provide assurance that the correct one is being used and that it is not contaminated with others. In addition, it is necessary to evaluate stored pitching yeast. At its simplest, this may take the form of a measurement of viability. Increasingly, tests are being developed which assess the physiological condition of the viable fraction.

13.2 Measurement of yeast biomass

Yeast biomass can be measured in several ways (Table 13.1). Individual methods have advantages and disadvantages. No single procedure is absolutely precise and the results of individual methods are not always comparable. Care must be taken, therefore with the interpretation of results. This confusing situation is explicable in that different methods have been developed to fulfil specific needs. Typically, a compromise is made between rapidity and precision. Thus, although all methods have some shortcomings, individual procedures are useful providing they are used for the application that they were designed for.

Direct methods of biomass determination use two general approaches. The first group of methods are those which measure the proportion of weight (or volume) due to cells within a suspension. The simplest method is to centrifuge a sample of slurry in a graduated tube. The volume fraction of packed yeast cells can be read directly from the scale on the tube. More commonly, the cell fraction is recovered by centrifugation or filtration from a slurry sample of known weight. The biomass concentration is expressed as percentage wet weight of yeast solids. Both procedures are rapid but subject to an error if trub is present. This can be minimized by treating with alkali, which dissolves some of the non-yeast solid material.

Assessment of yeast biomass concentration based on wet weight introduces an error due to variable amounts of the liquid phase, which are trapped in the interstices of the packed cells. This can be overcome by taking a sample of slurry of known weight or volume, washing the cells in water to remove the suspending medium and drying to remove both intra and extracellular liquid. Biomass concentration is expressed as dry weight per unit volume of slurry. This method provides a high degree of precision, but it is time-consuming. The second direct approach is to count the numbers of cells suspended in a liquid using a microscope and a haemocytometer counting chamber (Section 13.10). Competently performed the procedure is precise and repeatable. It is rapid and therefore suitable where analyses are required for calculation or checking of pitching rates, etc. Since the yeast is examined directly, there is an opportunity to identify abnormalities or gross contamination. When used in conjunction with a vital stain the proportions of viable and dead cells can be estimated. The result is not affected by trub, but errors accrue where the yeast is heavily flocculent or a chain-former. The operator is the principal source of error.

The error associated with visual examination of yeast is eliminated by the use of electronic particle counters. These devices rely on suspending yeast in an electrolyte and passing the cells through a narrow orifice. Cells are registered in response to a change in electrical impedance. Most instruments can discriminate between particles of different sizes, reducing the error due to non-yeast solids. Nevertheless, any particle of similar size

to yeast cells registers in the result. Small yeast flocs or chains of cells introduce a further source of error. Problems associated with flocs can be reduced by prior treatment with a deflocculating agent such as maltose. This method is rapid and is most suitable for checking relatively low yeast counts such as are encountered in newly pitched worts or cask beers at rack.

The classical technique for determining cell concentration is the plate count. A sample of the test suspension is serially diluted and aliquots are spread onto plates of selected solidified medium. Plates are incubated under suitable conditions for the test organism and growth is allowed to proceed until discrete colonies are formed. These are counted and it is assumed that each arises from a single cell, therefore the colony count is directly related to the cell concentration in the test suspension. This approach has several advantages. It is possible to use selective media so that mixed populations of cells can be identified. It only detects viable organisms. The precision of the method is low since not all viable cells grow to form colonies and flocs or chains do not develop into discrete colonies. The method is slow, although it is possible to use a rapid slide culture technique where cells are detected as micro-colonies. This reduces incubation times from a few days to a few hours. This method provides historical data only and is mainly used for checking strain purity and for detecting contaminants.

Other indirect methods of biomass measurement are calibrated against one of the two direct approaches. Thus, an empirical relationship is established between biomass concentration and the measured parameter. Most of these approaches have no value in brewing. Two methods are used in brewing because they employ sensors which provide automatic in-line measurement of biomass concentration. The first detects yeast cells by light scattering. The second relies on the dielectric properties of intact cell membranes.

The optical device uses a sensor that detects yeast in response to near infra-red radiation (Reiss, 1986). The control system doses yeast into wort to achieve a pre-determined set-point of light scattering. This set-point is empirically derived for each yeast strain. A dual beam arrangement corrects for light scattering due to non-yeast solids in the unpitched wort. The shortcomings of this approach are that it does not correct for non-yeast solids present in the yeast slurry, it cannot be used with very flocculent strains and it requires a separate viability correction.

From an electrical standpoint, yeast cells suspended in beer or wort comprise a conducting medium and conducting cytoplasm, separated by a non-conducting plasma membrane. This juxtaposition allows cells to function as capacitors when subject to radiation of a suitable wavelength. In the case of yeast cells this is in the range of radio waves (Harris *et al.*, 1987). The measured capacitance is proportional to the total volume fraction bounded by membrane within the operating field. Since yeast cells of a given strain, grown under defined conditions, are of a relatively constant size, measured capacitance is directly proportional to yeast biomass concentration. A biomass probe based on this principle is used in production brewing. The measured capacitance can be calibrated against cell number or a derivative of cell mass. A separate calibration curve is required for each strain.

It has been successfully applied in systems for the automatic control of both yeast pitching and cropping (Boulton *et al.*, 1989; Boulton and Clutterbuck, 1993). This method has several advantages. It has a very wide operating range and can be used to quantify cell concentrations in pitching yeast slurries without the need for dilution. Providing the cell suspension is homogenous, the concentrations of flocculent, non-flocculent and chain formers can be determined with equal facility. Non-yeast solid materials do not interfere since they do not function as capacitors. For the same reason,

Table 13.1 Methods for determining biomass concentration

Method	Timing	Comments
Direct methods:		
1. Determination of % wet weight of yeast in slurry	Rapid	Suitable for direct weight of pressed yeast cake Suitable for analysis of pitching yeast slurries by centrifugation or filtration (IOB, 1997 (Section 1.15.1, p. 9)) Errors due to entrained trub Not suitable for low yeast counts (cask beer counts, pitched worts)
2. Determination of % dry weight of yeast in slurry	Slow	Reference method but requires 3 days at 110°C for reliable answer Errors due to entrained trub
3. Cell count with haemocytometer and microscope	Rapid	Suitable for all production analyses but requires skilled operator (IOB, 1997 (Section 1.15.1, p. 9)) No error due to trub Not suitable for very flocculent strains Provides opportunity to view yeast and detect abnormalities or gross contamination Can be used to determine viability in conjunction with vital staining
4. Electronic particle counters	Rapid	Suitable for quantifying yeast counts at low concentrations (cask beers, pitched worts etc.) (IOB, 1997 (Section 1.15.1, p. 9)) Not suitable for very flocculent and chain-forming strains Possible errors due to entrained trub

Indirect methods:

1. Plate count	Slow	Cells inoculated onto solid medium and after incubation colonies are counted. It is assumed that each cell gives rise to a separate colony (IOB <i>Methods of Analysis</i> , 1997) Not all cells in original suspension may be cultivable Errors with flocculent cells Can be made selective by choice of suitable medium
2. Nephelometry	Rapid	Light scattering at visible wavelengths used for rapid measurement of cell concentrations in laboratory research studies. Must be calibrated against other reference method since response is non-linear NIR light scattering used in a commercial automatic in-line pitching rate control system (Reiss, 1986)
3. Analysis of cellular constituents	Slow	Biomass concentration expressed relative to the concentration of a macromolecular constituent such as DNA or protein Only useful as laboratory research tool
4. Metabolic activity	Rapid	Biomass concentration inferred from a measure of metabolic activity such as the rate of oxygen uptake, CO ₂ generation, exothermy Only used as a research tool
5. Radiofrequency permittivity	Rapid	Biomass probe which infers cell concentration from capacitance measured in response to radiofrequency field (Harris <i>et al.</i> , 1987) Requires separate calibration for each yeast strain Suitable for laboratory and in-line use Responsive only to viable fraction of yeast slurries Automatic in-line systems for control of cropping and pitching (Boulton <i>et al.</i> , 1989; Boulton and Clutterbuck, 1993)

the probe can be used to quantify yeast mixed with inert support materials in immobilized cell reactors. Yeast cells with disrupted plasma membranes, and which score as being non-viable with a vital stain such as methylene blue, lose their dielectric properties and are not detected. Thus, the probe is responsive only to viable cells.

For any given yeast strain, grown under defined conditions, cell number and biomass weight are positively correlated. However, the relationship is dependent on the physiological state of the cell. For example, prolonged storage of pitching yeast results in the depletion of intracellular glycogen. In brewing yeast this reserve material can account for up to 30% of the cell dry weight (Section 12.5.7). Thus, in such a slurry, a plot of cell numbers would show little change with time until a point is reached when cells die and lysis occurs. However, a similar plot of cell dry weight would show a gradual decrease throughout the storage phase as glycogen reserves were dissimilated.

13.3 Batch culture

In a batch culture cells are inoculated into a medium with a finite supply of nutrients. This is the most common situation in commercial fermentations, including brewing. It is the most usual mode of growth in natural habitats. A number of distinct phases can be recognized (Fig. 13.1). These phases are common to all micro-organisms that reproduce by cell division. However, the budding habit of *Saccharomyces* yeast introduces some specific features. The duration of each phase is dependent on cultural conditions, the nature of the growth medium and the physiological condition of the inoculum. The lag phase represents a period of adaptation when cells undergo a transition from one set of conditions to another. Thus, cells in the inoculum may have to synthesize the enzymes that are needed for the uptake and utilization of substrates present in the medium. In addition, abrupt changes in temperature or osmotic potential may induce a stress response, which requires a period of recovery from before growth commences.

The cells present in an inoculum are not identical. In the case of budding yeast, such as *S. cerevisiae*, there may be differences in physiological condition, stage in the cell cycle and cellular age. The duration of the lag phases of individual cells varies, and a finite period is required before the metabolic changes associated with adaptation are completed. The result is a progressive transition from lag phase to growth phase and hence, the period of accelerating growth. The growth rate gradually increases until it reaches a maximum and constant value. This is the exponential growth phase where the population increases logarithmically. The nature of the organism, the composition of the medium and physical conditions such as temperature, pressure and degree of agitation determine the rate. Cells removed at this stage and transferred to a fresh batch of similar medium will continue to grow exponentially without a lag phase. Individual cells within the exponentially growing population divide at different times, but the graph of biomass against time increases smoothly since it represents the averaged concentration for the whole population. Such cultures are termed asynchronous. Various experimental procedures can be followed to synchronize the cell cycles of the entire population. For example, treatment with a mitotic inhibitor causes cells to arrest at the same stage in the cell cycle. When the inhibitor is removed all the cells progress through the cell cycle in synchrony. Synchrony is usually maintained for the first two or three rounds of budding and plots of biomass concentration against time are stepped. After this time the culture gradually returns to the usual unsynchronized mode. In the case of budding yeast the loss of synchrony is hastened by the differing cell cycle times of mother and daughter cells (Section 11.7). The exponential phase

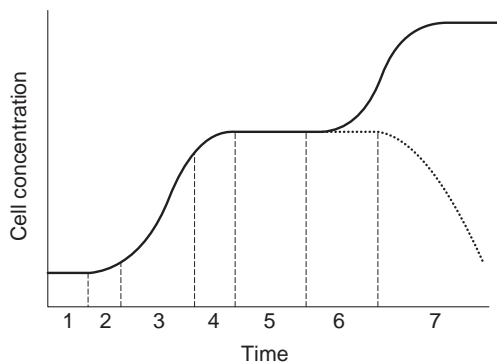

Fig. 13.1 Growth of yeast in batch culture on a medium such as wort in which sugar is the principal carbon source. For a detailed explanation see the text. The phases indicated are: 1, lag phase; 2, period of accelerating growth; 3, exponential growth phase; 4, decelerating growth phase; 5, stationary phase; 6, diauxic shift phase; 7, second growth phase on ethanol if oxygen present (solid line), or death phase if no oxygen present (dotted line).

of growth may end when a by-product of metabolism increases to an inhibitory concentration. More usually it terminates when an essential component of the medium becomes depleted. Eventually, the concentration of the essential nutrient falls to a level at which it limits the growth rate and the culture moves into the decelerating phase of growth.

When growth ceases the cells enter the stationary phase. During this phase the biomass remains at a constant level. This apparent inactivity is illusory since metabolic activities of various kinds continue. Aerobic cultures of *S. cerevisiae* growing on glucose as the principal carbon source have a bi-phasic growth curve, termed diauxie (Fig. 13.1). During the first phase, cells grow at the expense of glucose. The effects of catabolite repression (Section 12.5.5) ensure that metabolism is fermentative and ethanol is produced. During the first stationary phase, the absence of glucose relieves catabolite repression. After a period of adaptation and providing oxygen is available the derepressed cells are able to utilize the ethanol and a second phase of growth occurs.

When no further growth is possible the cells remain in the stationary phase, often referred to as the G_0 phase. During this time cells undergo changes that maximize their chances of survival. Predictably, this involves a shutting down of unnecessary metabolic pathways. Rates of protein synthesis are 300-fold lower in stationary phase yeast cells compared with those in the exponential phase (Fuge *et al.*, 1994). Other changes occur that influence the metabolism and morphology of cells. Glycogen is dissimilated to provide carbon and energy for cellular maintenance. Some of the carbon is used to synthesize trehalose, which increases tolerance to stress (Section 12.5.7). Cell walls become thickened and more resistant to enzymatic degradation. Cells are more resistant to heat and desiccation. Cytoplasmic vacuolation becomes more extensive, presumably reflecting an increased requirement for turnover of intracellular protein.

The metabolic changes associated with entry into the stationary phase are mediated at the gene level. Probably the *RAS* cyclicAMP signal transduction pathway controls entry into and exit from stationary phase. It is assumed that the cell has a method for sensing the concentrations of nutrients and is able to initiate the necessary changes for entry into the stationary phase when it is apparent that the supply of an essential nutrient is about to disappear from the medium. Certainly, specific genes appear to be induced just before the stationary phase commences. Others are expressed only in stationary phase cells. The role of many of these remains to be elucidated (Werner-Washburne *et al.*, 1996).

The stationary phase is transitory. The strategy of cells is to adapt to a physiological state that offers the longest survival time. During the early stationary phase, readily dissimilated sources of carbon such as glycogen are utilized. When these are depleted the cell will, if necessary, utilize structural macromolecules. If no nutrients become available the stationary phase terminates in death. The gross indication of this is a decrease in biomass concentration due to cell lysis; there is a loss of cellular integrity and a concomitant release of intracellular contents into the medium. The liberated cellular components can be utilized by other, still viable cells and even promote limited, cryptic growth.

The different growth phases in a batch culture can be described mathematically. The rate of increase of biomass (x) with respect to time (t) can be expressed as:

$$\frac{dx}{dt} = \mu x \quad 13.1$$

Where μ is a constant termed the specific growth rate and has the unit of reciprocal time (h^{-1}). During the lag and stationary phases it is equal to zero. It increases throughout the phase of accelerating growth and achieves a maximum value (μ_{max}) during the exponential phase.

During exponential growth the rate of increase of biomass concentration becomes:

$$\frac{dx}{dt} = \mu_{\text{max}} x \quad 13.2$$

After integration and where x_0 equals the initial biomass concentration, this yields the equation:

$$\ln x - \ln x_0 = \mu_{\text{max}} t \quad 13.3$$

This can be rearranged to give the fundamental exponential growth equation.

$$x = x_0 e^{(\mu_{\text{max}} t)} \quad 13.4$$

From this equation it follows that a plot of $\ln x$ versus t is linear with a slope equal to μ_{max} .

The exponential phase of growth is conveniently quantified in terms of the time taken for the population to double in size. The doubling time (t_D) is equal to:

$$t_D = \frac{\log_{10} 2}{\mu_{\text{max}}} = \frac{0.693}{\mu_{\text{max}}} \quad 13.5$$

The number of doublings (n) which occur to reach a final biomass concentration of x is given by:

$$n = \log_2 \frac{x}{x_0} \quad 13.6$$

$$n = 3.32 \log_{10} \frac{(x)}{x_0} \quad 13.7$$

At the end of the exponential phase, the growth rate μ becomes dependent upon the concentration of a growth-limiting substrate $[S]$. The relationship between growth rate and substrate concentration is expressed in the Monod equation:

$$\mu = \mu_{\text{max}} - \frac{[S]}{K_s + [S]} \quad 13.8$$

The constant, K_s , is termed the saturation constant and is equal to the substrate concentration where μ equals half μ_{max} . Plots of μ against substrate concentration show

saturation kinetics. The inflexion point at which growth rate becomes independent of the substrate concentration varies with different strains.

13.3.1 Brewery batch fermentations

The pattern of growth in a brewery batch fermentation is similar to that shown in Fig. 13.1. However, some aspects require further discussion. The initial yeast concentration in brewery fermentations is relatively high and the subsequent growth extent is modest. Thus, inoculation rates in a typical medium gravity (10 °P; SG c.1040) fermentation are approximately 3.0 g/l wet weight of yeast, equivalent to around 0.6 g/l cell dry weight, or in terms of cell numbers, approximately 1×10^7 cells/ml. During fermentation there are usually no more than two to three cell doublings. The consequence of this is that the yeast in the inoculum plays an important part in the subsequent fermentation.

The inoculum is usually derived from a previous fermentation and has been stored for a period before re-pitching. During the storage period the yeast is starving. It is usual to minimize the duration of the storage phase and to reduce metabolic activity by chilling to 2–3 °C (35.6–37.4 °F). Nevertheless, the physiological state of the inoculum coupled with the conditions established at pitch influence subsequent patterns of growth. During the lag phase the pitching yeast (which is usually suspended in beer) adapts to exposure to the nutrients present in wort. In particular, the yeast is exposed to oxygen (see Sections 12.6 and 12.7). The formation of sterol is accompanied by the concomitant mobilization of glycogen reserves (Fig. 13.2). There is a linear relationship between the quantities of glycogen dissimilated and sterol synthesized during fermentation (Quain and Tubb, 1982). The formation of sterol, coupled with glycogen mobilization, is a prerequisite for the cells to move from the lag phase to the accelerating growth phase (Section 12.6).

The events of very early fermentation in relation to the cell cycle are reviewed by Boulton and Quain (2001) (see also Section 11.7). Pitching yeast cells are in stationary phase (G_0) and unbudded. Transfer to wort induces a relatively synchronized shift to G_1 phase and progress to START. In the first few hours there is no change in cell number or wort gravity. However, cell volume increases by approximately 20% and biomass falls by a similar percentage. During this time sterol synthesis takes place at the expense of cellular glycogen and molecular oxygen. Within six hours of pitching, almost 90% of the yeast population is budding, indicating that nearly all cells have passed into the S phase. The increase in budding index (relative number of budded cells) is very rapid, indicating a high degree of synchrony during very early fermentation. The achievement of high budding index corresponds with the onset of biomass increase and decrease in wort gravity.

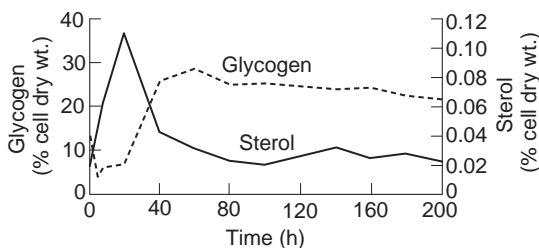

Fig. 13.2 Changes in the intracellular concentrations of glycogen and total sterol in yeast measured during the course of a laboratory stirred fermentation using a lager yeast strain and 12 °P all-malt lager wort (S. G. P. Durnin, unpublished results).

The increase in mean cell volume observed immediately after pitching is transitory. As the growth rate increases into the exponential phase, the mean cell volume decreases to a value similar to or slightly smaller than that seen at pitch. In the exponential phase, the population of yeast is made up of typically 25% multi-budded cells, 25% single-budded cells and 50% virgin daughters. The budding index also decreases from the initial high value and falls close to zero just after the mid-point of fermentation. Cell number increases to a constant value at the time that the budding index reaches a basal value. Biomass, measured as cell dry weight, declines slightly from the mid-point to the end of fermentation, reflecting the dissimilation of glycogen that occurs when growth has ceased.

The decline in budding index to a value close to zero just after the mid-point of fermentation indicates that at this time growth is limited by the disappearance of a nutrient. In the majority of fermentations, made from all-malt wort, the limiting nutrient is probably oxygen and, by inference sterols and/or unsaturated fatty acids. In highly oxygenated worts, particularly those containing high levels of sugar adjuncts, nitrogen may be the limiting substrate.

13.3.2 Effects of process variables on fermentation performance

The batch growth curve is influenced by a number of physical parameters. These are; temperature, pitching rate, dissolved oxygen concentration, wort concentration and pressure. Adequate control of these parameters is essential to ensure consistent fermentation performance and beer quality. Specific effects can be ascribed to modulating each parameter in isolation, nevertheless, they are all to some extent interdependent. For example, increasing fermentation temperature reduces oxygen solubility. Similarly, a decrease in wort concentration increases oxygen solubility. When examining the effects of altering a single parameter it is essential to ensure that all others remain constant. Some of the effects described will be observed only if the parameters are varied over very wide ranges. These extremes will not be seen in real brewery fermentations because they are beyond the limits that would be used in practice, but they serve as useful illustrations of the underlying principles.

An increase in the fermentation temperature reduces the time taken to attenuate the wort (Fig. 13.3). Thus, temperature exerts its effects primarily on yeast metabolic rate. It

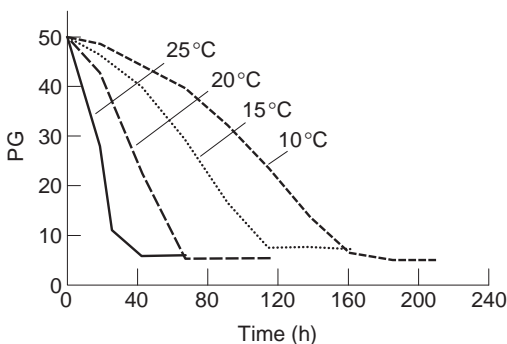

Fig. 13.3 Effect of temperature on fermentation rate. Fermentations were performed at the temperatures indicated using pilot scale 8 l cylindroconical fermenters, a lager yeast strain, pitched at a rate of 12×10^6 viable cells/ml into an all-malt lager wort with an OG of 1050 (12.5 °P) and an initial dissolved oxygen concentration of 25 mg/l (Boulton and Box, unpublished data).

has little effect on the extent of yeast growth during fermentation. Most brewing strains have an optimum temperature for growth between 30 and 34 °C (86–93.2 °F) but fermentations are maintained at lower temperatures. Superficially, the use of elevated temperatures for minimizing vessel turn-round times appears to be an attractive strategy. There are several disadvantages. At high temperatures, especially in cylindrical vessels, fermentation is very vigorous. Rates of CO₂ evolution are very rapid and losses of volatiles, via gas stripping, may become unacceptable. Indeed, beer losses due to uncontrollable foaming may occur. To avoid this it may be necessary to operate fermenters with a large freeboard. The consequent reduction in vessel productive capacity offsets some of the gains made by shorter vessel residence times. At the end of fermentation, the time taken to chill is directly proportional to the fermentation temperature.

Generally, ale fermentations are performed at higher temperatures (18–22 °C; 64.4–71.6 °F) compared with lager types (8–15 °C; 48.4–59 °F). These temperatures are chosen largely because they produce a desired spectrum of yeast-derived beer flavour components. Deviating from the normal temperature ranges may produce totally unacceptable shifts in beer flavour. Increasing the fermentation temperature leads to increases in the concentrations of higher alcohols and esters during fermentation (see Sections 12.10.3; 12.10.4). These flavour changes are particularly undesirable in the case of pale lager beers.

The concentration of oxygen supplied in wort at the start of fermentation is one of the primary regulators of yeast growth (see Sections 12.6, 12.7). Although wort composition is also influential, there is a direct correlation between the initial dissolved oxygen concentration and the extent of yeast growth. Elevation in oxygen concentration results in an increased primary fermentation rate. Caution must be exercised in using very high oxygen concentrations as a means of reducing fermentation times. High oxygen concentrations produce rapid primary fermentations but this may be at the expense of ethanol yield. The increased availability of oxygen promotes high rates of yeast growth at the expense of sugar, which would otherwise be available for ethanol formation (Fig. 13.4). Since oxygen has a direct effect on the extent of yeast growth, it would be predicted that it would also influence the concentrations of flavour metabolites produced as a result of yeast growth. This is indeed the case. With many yeast/wort combinations, but not all, there is an inverse correlation between initial oxygen concentration and beer ester levels.

At low values there is a direct correlation between the yeast pitching rate and the rate of primary fermentation and the extent of yeast growth. At higher pitching rates an inflection point is reached beyond which yeast growth decreases and there is no further increase in primary fermentation rate (Fig. 13.5). These observations reflect the interrelationships between yeast pitching rate and wort composition, in particular the initial dissolved oxygen concentration. Brewery fermentations differ from most other commercial fermentations in that the size of the inoculum is high relative to the extent of subsequent growth, so the ratio between the initial yeast concentration and available nutrients becomes a significant factor.

At low pitching rates (below the inflection point), there is a direct relation with attenuation rate. Total yeast growth is probably limited by oxygen-dependent lipid synthesis. Thus, there is a surplus of oxygen relative to the number of yeast cells present. However oxygen is also expended in other non-lipogenic pathways (Section 12.5). The small initial yeast population becomes lipid replete but subsequent daughter cells are limited by the onset of anaerobiosis. Below the inflection point, yeast growth extent and

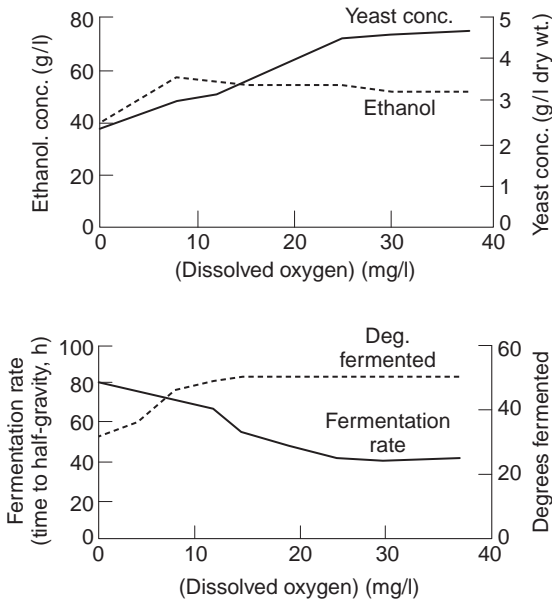

Fig. 13.4 Effect of varying initial dissolved oxygen concentration on fermentation rate (expressed as time to reach half-gravity) and the formation of ethanol and new yeast growth during the fermentation of a 15 °P lager wort with a lager yeast strain. The temperature was 11 °C and the pitching rate was 15×10^6 viable cells/ml (redrawn from Bamforth *et al.*, 1988).

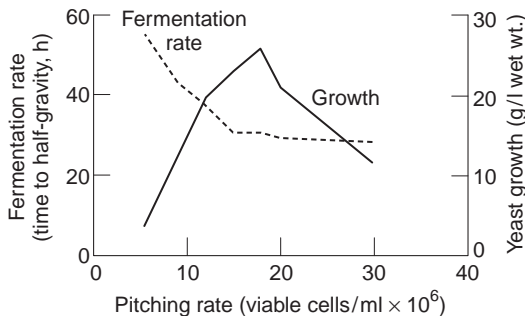

Fig. 13.5 Effect of pitching rate on fermentation rate (time to half-gravity) and new yeast growth (weight of crop – weight of yeast pitched) for 8 hl pilot scale all-malt 15 °P lager fermentations. The initial wort oxygen concentration was 25 mg/l and the pitching rate was 12×10^6 viable cells/ml (re-drawn from Boulton and Quain, 2001).

pitching rate are directly related. With increasing pitching rate a point is reached where growth is limited by the nutrient supply available to each yeast cell. The quantity of oxygen supplied per yeast cell is probably the limiting nutrient. Attenuation rates remain high because of the high yeast population. The patterns of growth and fermentation rates shown in Fig. 13.5 will be modified by other parameters such as the initial wort oxygen concentration and availability of other nutrients. Thus, at very high initial oxygen concentrations the inflection point at which growth begins to decline will be shifted towards the right. The inflection will still occur because another nutrient will eventually become growth limiting.

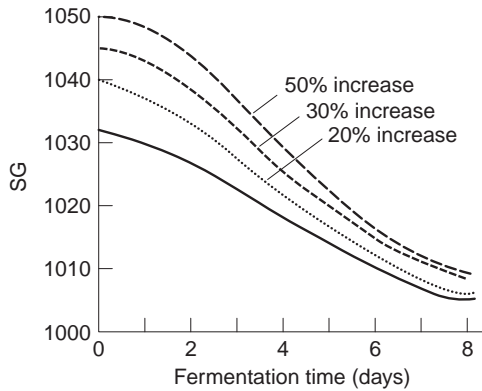

Fig. 13.6 The relationship between fermentation time and increasing the original gravity of wort from 1033.3 (8.3°P) in cylindroconical fermenters (redrawn from Hough *et al.*, 1982).

Increasing the wort concentration, without changing any other parameters, results in an increase in fermentation time. However, providing the pitching rate and wort dissolved oxygen concentration are increased *pro rata*, there is only a small increase in fermentation times (Fig. 13.6). This forms the basis of high-gravity brewing in which concentrated worts are fermented and subsequently diluted to sales gravity. Fermentation profiles are influenced by wort composition, such as variations in the spectrum of fermentable sugars. Some of these effects are strain-specific. Lager strains utilize maltotriose more rapidly than ale strains (Stewart *et al.*, 1995). It would be predicted, therefore that a change in the concentration of this sugar would have different effects depending on the nature of the yeast strain. At limiting concentrations, fermentation rates are proportional to the concentration of α -amino nitrogen (Fig. 13.7). In an all-malt wort the supply of α -amino nitrogen should be adequate and this dependence should not be observed. Deficiencies may arise in high-gravity worts made with a high proportion of non-malt adjunct.

Several distinct effects can be ascribed to pressure. Yeast is subjected to an osmotic pressure the magnitude of which is dependent on the concentration of the wort. In high-gravity worts the osmotic pressure may be as high as 4×10^6 Pa (Owades, 1981). Yeast

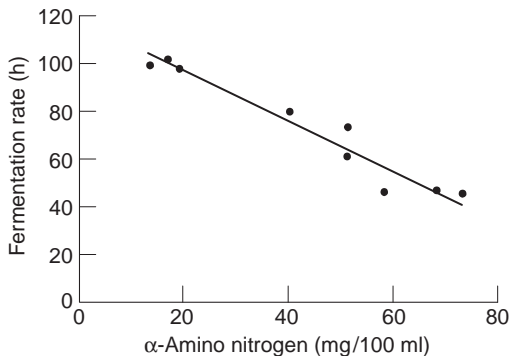

Fig. 13.7 Relationship between fermentation time and α -amino nitrogen of the wort (redrawn from Hough *et al.*, 1982).

cells appear unaffected by these pressures providing they are not subjected to abrupt changes. Osmotic pressures up to 10^8 Pa are tolerated by yeast (Gervais *et al.*, 1992). The osmotic potential of aqueous media is directly proportional to the concentration of dissolved solutes. This parameter is inversely related to the concentration of available water and is referred to as the water activity (A_w). All organisms are able to tolerate a given range of A_w . This parameter appears to be of greater significance to brewing yeast than osmotic potential *per se* (Chapter 12; Section 12.3.1).

In fermenters yeast is subjected to a hydrostatic pressure that is a function of the height of the vessel. In addition, if the exit of CO_2 produced during fermentation is restricted, the vessel will become pressurized. Very high pressures are deleterious to yeast. Very high-pressure treatments ($> 10^8$ Pa; 100 Bar) have been used to sterilize some foods where heat treatments cause deleterious flavour changes. In similar fashion to the dual effects of osmotic pressure and water activity, pressurization of fermenters leads to a concomitant increase in the concentration of dissolved CO_2 . The latter may have a greater effect on yeast than pressure alone (Thibault *et al.*, 1987).

Moderate top-pressurization of fermenters ($1.2\text{--}2.0 \times 10^5$ Pa, 1.2–2.0 Bar) has been used to reduce yeast growth and control fobbing. This approach has been used where changing other parameters, such as the use of very concentrated worts or elevated temperature, has resulted in unacceptable perturbations in the formation of flavour metabolites due to increased yeast growth (Nielsen *et al.*, 1986, 1987). The effects due to pressure are strain-specific. Using a spheroconical fermenter Posada (1978) reduced yeast growth by the application of pressure. However, depending on the yeast strain this was accompanied by both upward and downward shifts in the concentrations of various flavour metabolites. Miedaner (1978) described a protocol for high-temperature fermentations in which vessels were allowed to pressurize to approximately 1.8×10^5 Pa (1.8 Bar) at a point when the wort was approximately 50% attenuated. This resulted in a reduction in yeast growth and levels of higher alcohols compared to unpressurized lower-temperature fermentations. Comparative analysis of beers suggested that this was at the expense of some damage to yeast. Thus, the pH of the trial beer was higher and head retention values were reduced, possibly due to the presence of greater than normal concentrations of short chain fatty acids. Both of these effects suggest yeast autolysis.

13.4 Yeast ageing

Most analyses of yeast growth consider the dynamics of whole populations of cells. Biomass is estimated by cell number or cell weight. Where population analyses are performed they are often rudimentary, for example assessments of the proportions of living and dead cells. Where the viable population is analysed, as in the so-called vitality tests, most assessments are based on mean values of all the cells within the sample. These approaches assume that there is no heterogeneity within yeast populations. Budding yeasts differ from organisms that reproduce by binary fission in that individual cells have a finite life span determined by the number of times that it buds and its DNA is replicated. Replicative age is distinct from chronological age. When cells are unable to bud further they become senescent and ultimately they die (Jazwinski, 1999; Powell *et al.*, 1999). Replicative age of yeast is measured relatively easily in that each budding event leaves a characteristic scar on the cell wall. This can be visualized with fluorophores such as the dye, calcofluor. The maximum number of times individual strains are able to bud is

strain-specific and varies between about 15 and 40, usually \pm about 10. This number is termed the Hayflick limit (Hayflick, 1965).

Ageing is accompanied by morphological changes. The cells gradually take on a wrinkled and granular appearance. There is a positive correlation between cell age and cell volume (Barker and Smart, 1996), and for a lager strain a plot of cellular size versus age was linear. There was a sixfold difference between the size of young mother and senescent cells. Typically, generation times increase sharply just before the onset of senescence. Cells entering the senescent phase commonly fail to separate from daughter cells. The senescent phase culminates in death. In higher eukaryotes this process is termed apoptosis or programmed cell death. It is not a random process. In multicellular eukaryotes cells are continually dying and being replaced. Death appears to be under genetic control and occurs when cells have degenerated, possibly as a consequence of damage by reactive oxygen radicals (Madedo *et al.*, 1999). The apoptotic pathway has not been positively identified in yeast but it is possible that cells undergo suicide for similar reasons. In yeast, death is accompanied by autolysis, literally self-digestion. The process involves loss of membrane integrity and the breakdown of cellular macromolecular components by a variety of hydrolytic enzymes.

Yeast cell ageing may serve as a model for the same process in higher eukaryotes, including man. In brewing it may also have relevance to fermentation management. Brewing yeast populations may be heterogeneous with respect to age. Given the relation between replicative age and cell size it might be supposed that old and young cells would have different sedimentation characteristics in the cones of cylindroconical fermenters. This was the case in a 2000 hl fermenter (Deans *et al.*, 1997). Yeast cells at the bottom of the cone were, on average, older than those at the top. The fermentation performance of the older yeast fraction was significantly poorer compared to younger cells. This prompted the suggestion that the first portion of crops from these vessels should be discarded. In another investigation (Quain *et al.*, 2001) contrary results were obtained. In this case yeast cells of different average replicative age were fractionated using sucrose gradient centrifugation. The fermentation performance of each fraction was compared. The larger older cells produced fermentations with faster attenuation rates compared to the smaller younger cells. It is difficult to reconcile these diametrically opposite results. In both investigations there were significant differences between fermentation performance and replicative age suggesting that more detailed investigations are needed.

13.5 Yeast propagation

Theoretically there is no limit to the number of times that yeast may be serially cropped and re-pitched. Some traditional breweries, particularly those using top-cropped ale strains, have followed this practice for many years without interruption. Most modern breweries periodically introduce new cultures of yeast of guaranteed identity and purity derived from laboratory stocks. This is done for several reasons. Where several yeast strains are used within the same brewery low levels of contamination are inevitable and there is a constant threat of contamination with wild yeasts and spoilage bacteria. Acid washing (Section 17.6) should control spoilage bacteria, but it has no effect on wild yeast.

With prolonged serial fermentation the characteristics of the production yeast may change due to genetic instability. Petite mutants, which lack the ability to form functional mitochondria, are very common in brewing yeasts. Petites ferment abnormally (Ernandes

et al., 1993). Other types of genetic instability have been observed in brewing yeast, particularly changes from a relatively non-flocculent to a flocculent character (Section 11.8.2). Bottom-cropping yeast from cylindroconical fermenters can select for these more flocculent variants. This effect may be exacerbated with repeated serial fermentation. Bottom cropping has been associated with other undesirable effects. Prolonged serial cropping can result in a progressive enrichment of pitching slurries with trub and other non-yeast particulate matter. Not only is this trub added to the next fermentation, it results in an underestimate in the calculation of pitching rate where this is determined by measurement of spun solids. Bottom cropping may tend to select for larger and therefore older cells (Smart and Whisker, 1996; Deans *et al.*, 1997). This effect may contribute to a gradual decline in the performance of brewing yeast with generational age.

Typically, yeast is serially repitched between 5 and 20 times before disposal. This wide range reflects the importance that individual brewers place on the need to introduce new cultures. Conversely, it reflects the threat that individual brewers consider is posed by prolonged serial re-pitching. Propagation attracts both capital and revenue costs. It is commonly asserted that newly propagated yeast does not produce standard fermentation performance or beer, so there is a natural reluctance to propagate frequently, especially if existing yeast lines are performing in a satisfactory manner. The suggestion that newly propagated yeast performs poorly is unproven and may simply reflect less than ideal propagation plant. The decision to introduce a new culture should be based upon microbiological and performance testing of existing yeast. The process should be managed so that a new culture is introduced when experience suggests that older cultures will be approaching the end of their useful lifecycles.

Yeast propagation has three elements. Firstly, there is a need to maintain stock cultures. Secondly, the stock culture must be used to generate a laboratory culture of a scale sufficient to pitch the first brewery culture. Thirdly, the yeast must be propagated within the brewery to grow an amount sufficient to pitch the first production scale fermentation.

13.5.1 Maintenance and supply of yeast cultures

The complexity of the system used for the maintenance of stock cultures depends on the size of the operation. It must be a quality assured system in which cultures of guaranteed identity and purity are delivered to the brewery. Several levels of complexity are possible. Small breweries using a single yeast strain may hold stock cultures at independent third-party institutions such as the various national collections of yeast cultures. The onus for guaranteeing the quality of the supplied yeast is placed, at a cost, on the institution. This approach has the advantage of simplicity. Many brewers maintain their own strains. This can range from a requirement to look after a single strain at one brewery to multiple strains supplied to several breweries. Where a single company has to supply several satellite breweries and possibly a number of franchise breweries with a number of yeast strains it is convenient to have a dedicated central facility. This facility replaces the third-party operators and takes on the task of quality assurance of cultures and their supply. The satellite breweries have the much reduced burden although still essential task of assuring the supply of cultures from their own brewery laboratories into propagator and thence production. Alternatively, the central facility may undertake propagation and supply bulk yeast to breweries.

There is a need to store cultures for long periods in such a way that they remain pure, at high viability and not subject to genetic change. Several methods are used and they

fulfil these criteria with varying degrees of success. The simplest method is by periodic sub-culture using agar slopes (slants). These consist of small bottles, typically containing around 10 ml of a suitable nutrient medium, solidified with agar. In order to maximize the surface area, the agar is allowed to solidify with the bottle placed at a slant, hence the name. The agar is inoculated with a pure culture of yeast and incubated to provide a profuse layer of growth on the surface of the agar. Slope cultures are stored at 2–4°C (35.6–39.2 °F) to minimize yeast metabolic activity and prolong the maximum storage period. Periodically slopes are sub-cultured by transfer to fresh medium. This approach is simple and inexpensive and, providing skilled personnel perform it, should not result in loss of purity. It has the major disadvantage that while metabolism is slowed by cold storage it is not stopped. Prolonged storage results in loss of viability, nevertheless cultures can be held in this way for 4–6 months. To allow a margin for safety, slopes should be sub-cultured every three months. The most serious disadvantage of this method is that over long periods of time and following multiple sub-culturing genetic drift and selection of non-standard variants has occurred (Kirsop, 1991).

More sophisticated storage methods seek to slow down metabolism further than can be achieved by chilling alone and thereby prolong storage times. A popular method is that of lyophilization or freeze-drying. Cultures are rapidly frozen followed by drying under vacuum such that water is removed by sublimation. The process is performed in glass ampoules, which are sealed when drying is complete. These cultures can be safely stored for several months. Reactivation is achieved by breaking the ampoule and transferring the dried biomass to fresh liquid medium. This method is widely used but it has serious shortcomings. Freeze drying results in a large overall reduction in viability. The fraction that remains viable appears to do so for several months, thereafter but usually up to 95% of the original cells die during drying. More worryingly, the viable fraction may undergo some degree of genetic disruption during freeze drying (Russell and Stewart, 1981).

The death and deterioration that accompanies freeze-drying is probably caused by the formation of intracellular ice crystals (Morris *et al.*, 1988). In other industries, where the use of dried yeast is commonplace, yeast is cultivated in a manner that manipulates physiology to render the cells less susceptible to the rigours of drying. Thus, cells are encouraged to accumulate trehalose, a well-recognized stabilizer of biological membranes (Section 12.5.7) and protectants are added during processing. Guldfeldt and Piper (1999) reported that ale and lager strains stored in liquid nitrogen retained 100% viability after seven months storage. The same strains dried under vacuum in the presence of glucose suffered losses in viability between 10 and 99.6%. When yeast was subjected to an osmotic shock, in the form of exposure to sorbitol (20% w/v) prior to drying the viability decrease was reportedly much less.

The adoption of dried yeast as the method of choice for bakers has also been recommended to brewers (Debourg and Van Nederveelde, 1999). Fermentation performance and beer quality at pilot and production scale were comparable with those produced using conventional pitching yeast. Dried yeast is used in parts of Africa for making African-style opaque beer (Chapter 16). It is suggested that the use of dried yeast might replace conventional brewery propagation. Its use obviates the need for propagation and the subsequent storage of cropped pitching yeast. Theoretically, dried yeast should be of a consistent physiological condition and not suffer the variability that might be the case with conventional pitching yeast. On the debit side, bakers' yeast destined for drying is grown so that all cells are fully respiratory (Section 13.5). Such cells should be sterol

replete and have little or no requirement for oxygenation of worts. Proof is still required that brewing yeast in this state will give standard fermentation performance and beer with a normal volatile spectrum. Nevertheless, the use of dried yeast is an attractive option and may well find application where an infrequent supply is needed such as might be the case with franchise brewing, pub brewing and home brewing.

The most effective (and most expensive) method of preservation and storage of yeast cultures is freezing in liquid nitrogen (-196°C ; -320.8°F). Cultures must be frozen in a controlled manner but once this is achieved the storage potential is measured in years. Furthermore, no changes in genotype have been reported (Kirsop, 1991; Quain, 1995). As with the method for bulk drying bakers' yeast, the cells to be frozen are grown under oxidative conditions. Prior to freezing yeast is suspended (c. 30% wet wt/vol) in a medium containing glycerol (5% v/v) as a cryoprotectant. To maintain high viability the rate at which the temperature is lowered must be regulated. The temperature must be reduced slowly during the first phase, typically two hours from 20°C to -30°C (68 to -22°F). After this the yeast is rapidly cooled to -196°C (-320.8°F) by immersion in liquid nitrogen. The underlying principle of the process is that during the initial slow phase the suspending medium freezes first. Consequently, the osmotic potential of the suspending medium increases, a phenomenon assisted by the presence of the cryoprotectant. This causes intracellular water to be released into the medium and in consequence the cells shrink. The gradual shrinkage and dehydration prevents intracellular ice crystal formation.

Yeast is conveniently frozen in colour-coded sealed straws and held in purpose-built liquid nitrogen refrigerators. Yeast is recovered by plunging the straws into warm (37°C) water, broaching using sterile scissors then transferring the thawed slurry to sterile liquid medium. This is used to prepare a master culture from which slope cultures are prepared. At the same time checks of strain purity and possibly identity are made. The slopes are distributed to breweries for use in propagation. An ISO 9000 quality assured system for yeast preservation using liquid nitrogen, recovery of cultures and distribution to satellite breweries is described by Quain (1995).

13.5.2 Laboratory yeast propagation

The aim of laboratory propagation is to grow a pure culture of yeast of sufficient volume to pitch the first brewery scale propagation vessel. The process is performed using traditional microbiological techniques and mainly glass apparatus, preferably by skilled personnel. The importance of this stage is often underestimated. Ensuring that the culture is pure is of paramount importance. Although it is customary to confirm that the culture is free from contamination the test results may not be obtained until after the first brewery stage has been pitched.

To generate the terminal laboratory propagation culture it is necessary to grow a series of intermediate cultures of progressively increasing volume. A typical protocol is shown in Fig. 13.8. Scale up factors are usually around 1:10. The initial stages use a general-purpose yeast medium such as yeast extract, peptone glucose (YEPG). The terminal phase uses sterile brewery wort. The whole process takes around two weeks. Growth of yeast is promoted by continuous aeration. Terminal yeast counts should be within the range $150\text{--}200 \times 10^6$ cells per ml at a viability greater than 98%. The sub-terminal culture is carried out using an aspirator flask. The culture is aerated via a glass sinter fitted with a sterile gas filter. Good rates of oxygen transfer are encouraged by mechanical agitation using a magnetic follower. The outlet on the aspirator is fitted with silicone tubing and a

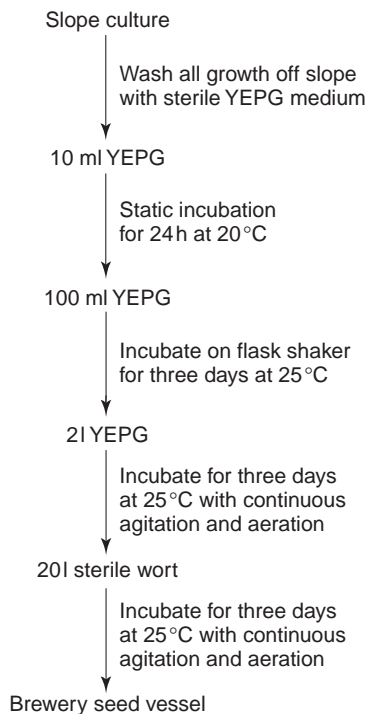

Fig. 13.8 Protocol for the laboratory phase of yeast propagation. All stages except the terminal step use a semi-defined medium (YEPG: yeast extract, 5 g/l; peptone, 10 g/l; glucose, 20 g/l).

coupling for attachment to the inoculation port on the apparatus used for growing the terminal laboratory culture. The latter piece of apparatus must fulfil three functions. It must be able to withstand autoclaving during sterilization of the wort. It must be suitable for growing pure cultures of yeast to high concentration without risk of contamination. It must be suitable for transferring yeast from the laboratory to the brewery, therefore it must be of robust construction to withstand the rigours of the production environment.

Suitable apparatus for carrying out the terminal phase of laboratory propagation is shown in Fig. 13.9. The flask has a total capacity of approximately 25 litres and is constructed from stainless steel. Several ports traverse a top plate that can be removed for filling with wort and for cleaning. These ports are attached to lines for inoculation, sampling, gas inlet and outlet and transfer to the brewery seed vessel. During the growth phase the wort is aerated using air delivered via a sterile gas filter and a stainless steel sinter. The wort is agitated using a magnetic follower. Transfer of the culture to the brewery seed vessel is achieved using a gas cylinder to provide motor gas delivered via the exhaust line. All gas lines are protected with sterile filters and all other lines are fitted with connectors, which are wrapped during sterilization. These are used to make aseptic connections when transfers are made.

13.5.3 Brewery propagation

The culture supplied by the laboratory is pitched into a small seed tank and thence through a further series of vessels of increasing volume until sufficient yeast has been

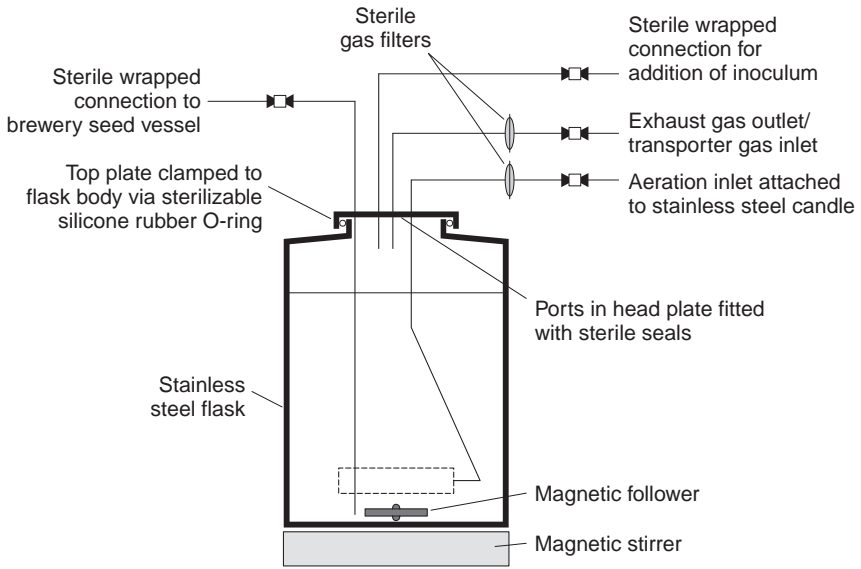

Fig. 13.9 Components of apparatus suitable for carrying out the terminal growth phase of laboratory yeast propagation. The flask has an operating volume of 20 l and a total volume of 25 l.

generated to pitch the first production fermentation. From a microbiological standpoint propagation is fraught with risk. Any contamination at this stage will have profound adverse consequences. The design of the plant, its operation and its internal finish must be to the highest hygienic standards. The propagation plant should be located within a room designed to minimize the risk of contamination. Access is restricted to essential personnel, all internal surfaces are made from hygienic materials, the air in the room is filtered and the atmosphere maintained under a slight positive pressure.

Wort is used as the propagation medium. Preferably, it should be of the same quality as that used in fermentation. This is usually not essential from the point of yeast growth but as the spent wort will eventually be pitched with the yeast it should match the wort it is pitched into. Yeast should not be propagated using high-gravity worts (Cahill and Murray, 2000). For ale and lager strains propagated on 7.5, 11.5 and 17.5 °P worts there was a progressive increase in the mean cell size and decrease in viability. Bearing in mind that ethanol is toxic and that actively growing cells are the most susceptible this is unsurprising (Section 12.5.9). Prior to inoculation the wort and vessel must be sterilized. The vessel may be sterilized empty and then filled with wort from the hot side of the paraflo. Preferably, propagation vessels are provided with a means of boiling wort *in situ* via steam jackets or direct injection of steam. Yeast growth is encouraged by provision of air or oxygen. Gas inlet and exhaust lines must be fitted with microbiological filters. Sampling and inoculation ports must be capable of aseptic operation, preferably sterilized by steaming.

The performance of the first fermentation should fall within the normal range in terms of duration and the extent of yeast growth. The resultant beer should be within specification. These goals are not always achieved. Traditional propagators operate on the principle that the yeast should, as far as possible, be in the same physiological condition as pitching yeast. The assumption is that this will ensure that the newly propagated yeast will produce standard fermentation performance when it is transferred

into the first wort. This is achieved by limiting the quantity of oxygen supplied to yeast during the growth phase and controlling the temperature at the same value or slightly higher than that used for fermentation. Traditional propagators tend to be of similar construction to fermenters. Thus, mechanical agitation is not provided and during the growth phase, aeration is not continuous. The downside to this approach is that the yield of yeast is low, usually no more than would be obtained from a conventional wort fermentation (typically, $50\text{--}60 \times 10^6$ cells per ml). The low yields associated with traditional propagation systems usually require several steps to generate sufficient biomass to pitch the first fermentation. Furthermore, scale-up factors between each phase are modest, not more than 1:5. A typical regime would require four stages of 1.5, 6.0, 30.0 and 150 hl, respectively to generate sufficient yeast to pitch up to 800 hl (500 UK barrels) of wort. The duration of the entire process, including the laboratory phase, takes several weeks. Thus, the process is slow, the use of multiple vessels is costly to install and operate. The risks of contamination are proportional to the number of vessels used.

In modern breweries, which may use several yeast strains, traditional propagation systems cannot easily satisfy the requirements for yeast. An additional complication is the use of very large fermenters. Commonly, very large fermenters have been installed without concomitant upgrading of the propagation plant. To overcome this problem it may be necessary to continue using smaller fermenters in parallel with the larger ones simply to generate sufficient yeast. Alternatively, large fermenters can be part-filled when pitched with newly propagated yeast.

To satisfy the increased need for propagation in large breweries it has been necessary to introduce methods for increasing the yield of yeast and accelerating the process. Consider a brewery producing beers with an average fermenter turn-round time of 12 days, using six yeast strains. Assuming yeast is serially pitched for 15 generations after which time a new culture is introduced, the total life-time of each yeast culture would be $(12 \times 15) = 180$ days. Assuming a propagation regime which required 35 days to complete (14 days laboratory stage + 21 days brewery stage) the total time required to accommodate all six yeast strains would be 210 days. Clearly, in this case it would be necessary to duplicate some of the propagation plant in order to meet the needs of the brewery.

Growing the yeast at a temperature higher than that used during fermentation accelerates the propagation process. High yields can be obtained by ensuring that conditions are fully aerobic. Aerobic wort propagation performed at $20\text{--}25^\circ\text{C}$ typically yields terminal yeast counts of $180\text{--}220 \times 10^6$ cells/ml. The growth phase requires 24–48 h to complete. Using a two-tank system, total turn-round times for the brewery phase, including cleaning and filling takes less than seven days. Providing the oxygen supply is discontinued when growth ceases, the physiology of the yeast remains catabolite repressed and is therefore, similar to that of pitching yeast (Section 12.5.8).

Several propagation systems have been described (Geiger, 1993; Schmidt, 1995; Brandl, 1996; Ashurst, 1990; Boulton and Quain, 1999; Westner, 1999). All are provided with a means of ensuring that high rates of oxygen transfer can be achieved. This requires two components. Firstly, a system for delivering sterile oxygen into the growing yeast culture, usually a sparge ring, candle or similar device and, secondly, efficient mechanical agitation to ensure that oxygen is dispersed throughout the culture. The essential features are shown in Fig. 13.10. The aspect ratio of the vessel is relatively high to maximize the path-length for oxygen solution. Vessels are jacketed to facilitate attemperation by cooling. Either sterile wort is delivered to the wort via an in-line pasteurizer/heat exchanger, or wort can be sterilized *in situ*. Sterile oxygen is delivered at

the base of the vessel via a stainless steel candle. High oxygen transfer rates are ensured by provision of a large mechanical rouser. If desired, the dissolved oxygen concentration may be regulated at a set point in a feed-back loop system using output from a dissolved oxygen probe located just under the surface of the liquid. The process generates considerable foam. Vessels with large freeboards contain this. In addition, foam can be controlled by application of top pressure and reducing agitation and gassing rates in response to a trigger from a high-level probe. Propagation in this way is conveniently performed within two vessels. The first, seed vessel is a similar to that shown in Fig. 13.10. The operating volume should be around 8 hl. The second vessel should be sized to achieve the desired pitching rate in the first fermentation. For example, a propagation vessel with an operating volume of 100 hl and a terminal cell count of $200 \times 10^6/\text{ml}$ would generate sufficient yeast to pitch 1300 hl of wort at a pitching rate of 15×10^6 cells/ml. In contrast to traditional propagation plant large step-up ratios can be used, typically 1:10 to 1:20.

13.6 Fed-batch cultures

During fermentation or aerobic propagation using wort, yeast metabolism is catabolite repressed by sugars (Section 12.5.8). This limits the yield of biomass to modest values. Biomass yields can be dramatically increased by growth under derepressing conditions. This can be achieved by using an oxidative carbon source such as ethanol or glycerol. Unfortunately, many yeast strains including most brewing types grow poorly on oxidative media. Biomass production can be encouraged by fed-batch cultivation, in which the nutrient medium is supplied to the growing yeast over a period of time. The nutrient feed rate is controlled with respect to growth rate so the sugar concentration remains at a low derepressing concentration since it is utilized as soon as it comes into contact with the cells. In practice, this can be achieved by inoculating a medium containing all necessary nutrients but a limited supply of sugar. After inoculation with yeast, growth is allowed to proceed until the small concentration of sugar is consumed. At this point additional sugar is added to the culture. Sugar addition is exponential at a rate that mirrors the batch growth curve. Total biomass yields can be increased approximately fivefold using this procedure, compared to catabolite repressed cultures.

Aerobic fed-batch techniques are used for the production of bakers' yeast. In contrast to brewing the aim of such processes is to generate biomass. In this respect formation of ethanol would be wasteful, hence the reliance on this method. Yeast is usually grown on an undefined medium such as molasses (Barford, 1987). The feedstock can be added in response to feedback from a sensor, which measures the concentration of a sugar. In this case addition rates are regulated to ensure that the sugar concentration remains at zero or a very low value. Most commercial systems add nutrient at a fixed exponential rate based on empirical observation of the growth of the yeast being cultivated. In order to ensure that growth remains oxidative it is essential that conditions are aerobic at all times. Since biomass concentrations reach very high values growth vessels must be capable of very high rates of oxygen transfer.

Fed-batch propagation of yeast has not been applied to the production of brewing yeast although it has been proposed (Masschelein *et al.*, 1994; Naudts *et al.*, 1997). Theoretically it is an attractive proposition since not only are biomass yields very high but derepressed yeast contains high concentrations of the essential membrane lipids, sterols and unsaturated fatty acids (Section 12.7). These high lipid levels should reduce or

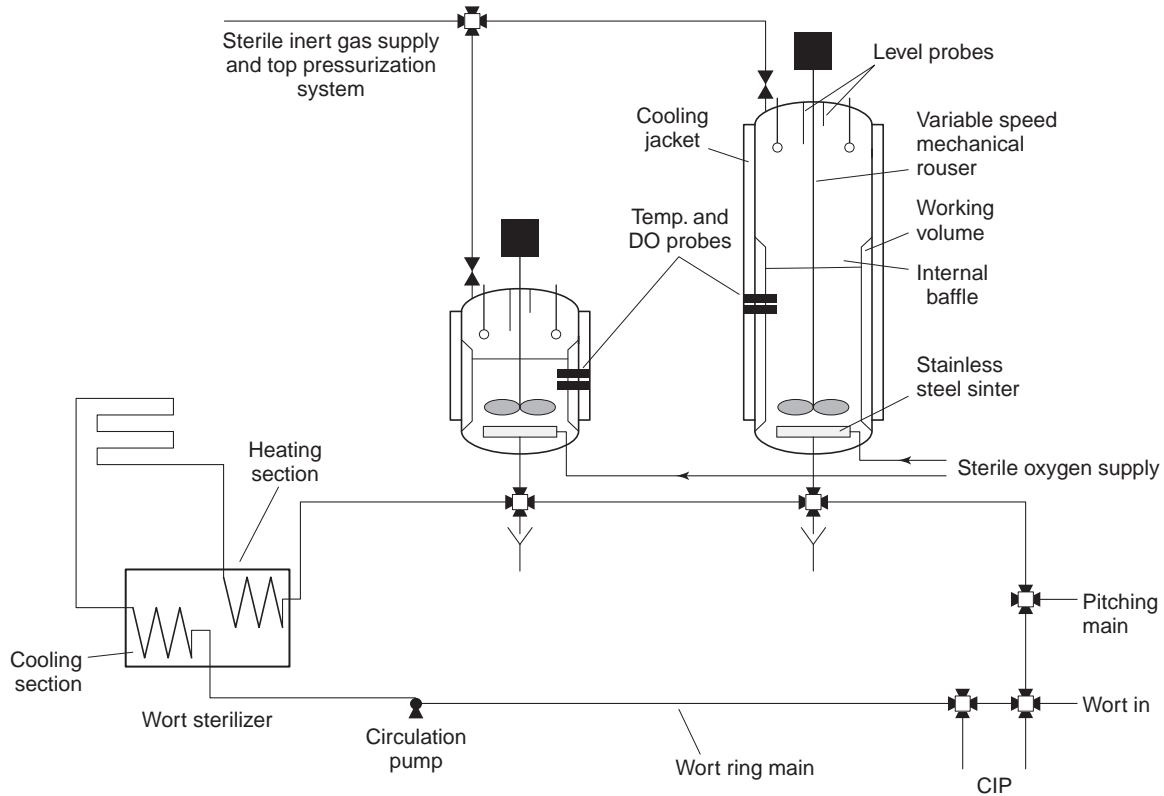

Fig. 13.10 Two tank aerobic brewery yeast propagation system. The working capacities of each vessel are 5 bbl (8hl) and 85 bbl (139hl), respectively (redrawn from Boulton and Quain, 1999).

eliminate the requirement for wort oxygenation. There is a reluctance to embrace this technology. The use of dried yeast in brewing is becoming more common (Fels *et al.*, 1999). Such yeast is grown using fed-batch cultivation. It seems likely that as approaches like this see more widespread adoption, so might the underlying growth technique.

13.7 Continuous culture

Batch cultures are closed systems in the sense that exhaustion of a nutrient or accumulation of a growth-inhibitory metabolite eventually limits growth. If a constant nutrient supply or a means of removing inhibitory metabolites is provided there is no reason why growth should not proceed *ad infinitum*. This is the underlying principle of open or continuous culture systems. Two approaches are possible (Pirt, 1975). A plug flow reactor consists of an extended culture vessel (Fig. 13.11). A controlled mixture of nutrient medium and inoculum are introduced into the vessel and pumped through it. The geometry of the vessel is arranged such that there is a minimum of mixing of the contents. As the medium and inoculum pass through the culture vessel the distance travelled is proportional to the stage in the growth cycle that would have been reached in a conventional batch cultivation. By manipulation of the flow rate, the dimensions of the vessel, the composition of the medium, inoculation rate and temperature it is possible to control the composition of the medium issuing from the fermenter. The process can be made truly continuous by separating the biomass from the process stream exiting the culture vessel and re-circulating a proportion to form the inoculum. Control of the conditions allow the establishment of a steady state.

The second and most common approach to continuous fermentation is the chemostat. In essence this consists of an attaperated stirred reaction vessel with an inlet medium feed and an outlet for removing product (Fig. 13.12). The pipework is arranged such that the volume within the reaction vessel remains constant. A variable speed pump controls the rate of medium inflow and product outflow. It is assumed that stirring is perfect such that incoming medium is instantly and homogeneously distributed throughout the growth vessel. Chemostat cultures are initiated by filling the growth vessel with medium. After

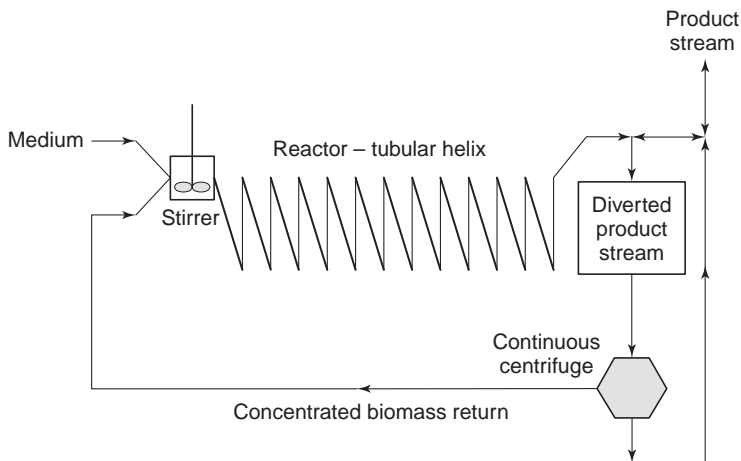

Fig. 13.11 A plug flow continuous reactor. In the scheme shown, a proportion of the biomass is recovered by continuous centrifugation and fed back into the flow of in-coming medium.

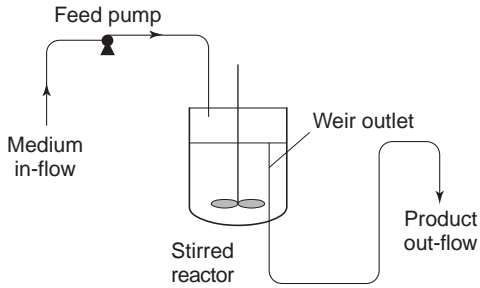

Fig. 13.12 Simplified representation of a chemostat. The outlet takes the form of a weir. This ensures that the volume in the reaction vessel remains constant.

inoculation, growth is allowed to proceed for a period to generate biomass. After the phase of batch growth the continuous phase is initiated by switching on the medium supply.

The theoretical basis of chemostat operation can be understood starting with a consideration of the general growth equation, the derivation of which is described in Section 13.3.

$$x_t = x_0 e^{(\mu t)} \quad 13.9$$

Where x_t is the cell population at time t ; x_0 is the cell population at zero time and μ is the specific growth rate. The latter function is defined as growth rate expressed as a function of the total biomass concentration. Consequently, it has the units of reciprocal time. The growth rate is controlled by the same environmental factors that regulate growth in batch culture such as temperature and availability of nutrients. Each organism has a maximum growth rate (μ_{\max}) that is determined by the genotype. It is expressed when growth is not limited by any external influence.

The instantaneous growth rate within a chemostat is described by the equation

$$\frac{dx}{dt} = \mu x \quad 13.10$$

The rate of loss of cells from the chemostat is given by

$$\frac{dx}{dt} = -Dx \quad 13.11$$

D is termed the dilution rate and is equal to the flow rate of incoming fresh medium divided by the volume of the growth vessel. It also has the unit of reciprocal time. Combining equations 13.10 and 13.11 gives an expression showing the net change in the concentration of biomass at any given time.

$$\frac{dx}{dt} = \mu x - Dx = x(\mu - D) \quad 13.12$$

From this equation it can be appreciated that for any given dilution rate, the population density will increase until a constituent of the growth medium becomes limiting and its concentration within the growth vessel tends towards zero. Under these conditions the biomass concentration and composition of the spent medium remain constant and are a function of the dilution rate. This situation is termed the steady state. As the dilution rate is increased the growth rate (μ) increases to accommodate the increased supply of nutrients. Eventually, the maximum growth rate (μ_{\max}) is achieved and any further increase in dilution rate results in a progressive loss of biomass, termed washout.

Both plug flow fermenters and especially chemostats have found widespread application as research tools. Chemostats are very powerful since they provide microbial biomass with a defined physiological condition. Furthermore, the consequences of changing physiological state on the biochemistry of the organism by manipulation of the medium composition, or growth conditions, can be readily assessed. Of greater significance here, they also form the basis of industrial processes.

Continuous brewing fermentation is an attractive prospect since it provides a method of harnessing the power of a highly active yeast population of defined physiological condition. Theoretically, it is possible to construct a process in which a continuous in-feed of wort is rapidly transformed into a continuous outflow of green beer. The yeast is actively growing at all times, thus the lag phase associated with batch fermentations is eliminated. The controlled and constant conditions within continuous fermenters should be reflected by beer of consistent composition. Since the process is continuous *ipso facto* there is no downtime due to vessel emptying, cleaning and re-filling. Similarly, since yeast is not cropped and retained for re-pitching, yeast handling is much simplified.

In practice, there are also many disadvantages to continuous fermentation. The flow rates can be varied within only comparatively narrow limits and only a single beer quality can be produced at any given time. Consequently, continuous systems are inflexible. There is a need for a constant supply of wort. Most breweries have plant suitable for discontinuous wort production (Chapter 6) and therefore a storage facility must be installed. The risks of microbial spoilage with bulk wort storage are considerable. The risks of contamination extend to the continuous fermenter. The consequences of contamination in the reactor are grave since start-up times and establishment of steady-state conditions are long. Some brewing yeast strains are genetically unstable (Section 11.8.2). Selection of mutant strains in continuous fermenters can have disastrous consequences. For example, some production scale continuous processes rely on the yeast being flocculent for retention within the vessel. Selection of non-flocculent variants results in washout.

The nature of brewery primary fermentation precludes the use of a chemostat. The assimilation of sugars by yeast growing on wort is an ordered process. The presence of glucose inhibits the assimilation of maltose (Section 12.4.1). Furthermore, the production of a balanced spectrum of flavour compounds is dependent on controlled yeast growth. In a chemostat culture, yeast growth extent may be significantly different from that seen in batch fermentation. Similarly, the constant addition of fresh wort can result in abnormal sugar utilization. For these reasons, continuous primary fermentation is best performed using a plug flow type reactor. Unfortunately, it is impossible entirely to eliminate back mixing. To avoid these problems and by way of compromise, multi-stage continuous systems may be used. In this case the physical separation of the process liquid into discrete reaction vessels allows the essential characteristics of a batch culture to be incorporated into a semi-continuous process (Stratton *et al.*, 1994; Williams and Ramsden, 1963). Alternatively, the fermenter takes the form of a vertical column (tower) in which wort is introduced at the base (Seddon, 1975). Use of a flocculent strain not only retains yeast within the vessel but also provides a self-generating gradient of biomass through which the wort passes. The pinnacle of interest in continuous fermentation was reached during the 1960s. During this period many systems were developed, some of which were used at production scale. Unfortunately, their use was bedevilled by failures. With a few notable exceptions the use of continuous fermentation systems was discontinued. Since that time there has been a resurgence of interest, especially using immobilized yeast reactors, as described in Section 13.8. A full review

of the historical aspects and current status of continuous fermentation can be found in Boulton and Quain (2001).

13.8 Immobilized yeast reactors

Immobilized yeast reactors are refinements of continuous fermentation systems. In the latter, some of the yeast exits from the vessel with the spent medium. This necessitates the use of additional plant, usually a continuous centrifuge, for separation of yeast and product. In continuous immobilized yeast reactors the yeast is retained within the vessel. Fresh medium enters the reactor and passes through the yeast biomass where it is transformed into product. The latter exits from the reactor essentially free from yeast.

Immobilized systems have several advantages compared to conventional continuous reactors. Process times are rapid and process efficiencies are high because of the combination of elevated biomass concentration and high volume throughput. Thus, because yeast loss is restricted, it is possible to use flow rates that would cause washout in a conventional chemostat. In an immobilized yeast reactor the relation between dilution rate and biomass concentration does not hold since cells are retained. Hence, it is possible to have high dilution rates and high biomass concentrations. High biomass concentration restricts growth, which also engenders high process efficiencies. High productivity allows the use of comparatively small immobilized yeast reactors. Clarification of the product stream is simplified because of the retention of biomass. In essence, the yeast in an immobilized system functions as a biocatalyst and no actual growth is necessary. The process has been defined as cells physically confined or localized within a specific region of space with retention of their catalytic activity, if possible or even necessary their viability, which can be used repeatedly and continuously (McMurrough, 1995).

Several systems for immobilization are used (McMurrough, 1995). Retention of flocculent yeast within a tower fermenter using upward flow is the simplest method. It is of limited use since it can be used only with very flocculent strains and high flow rates eventually result in washout of biomass. There are four methods for true immobilization of yeast. These are retention by a semi-permeable membrane, attachment to a surface, entrapment within a porous polymer and colonization of a porous material. Membrane reactors suffer the major disadvantage that the rate of exchange of solutes is slow. In consequence, they have not found application in production scale reactors.

Entrapment of yeast within the matrix of a porous polymer is possibly the most widely used method of immobilization. Polymers that have been used include polyacrylamide, calcium alginate, κ -carrageenan, agarose, pectin, chitin and gelatin (Godia *et al.*, 1987). Polymeric supports are conveniently formed into beads, typically around 0.3 mm diameter. Beads of this dimension offer the best performance with regard to diffusion of nutrients and metabolic by products from the surrounding medium to the immobilized cells. The mechanical strength of the bead is a function of the degree of cross-linking of the polymer. The latter also controls diffusivity of nutrients and metabolites from the medium to the yeast cells. The latter parameter is vital to the efficiency of these bioreactors hence it is usual to sacrifice some mechanical strength in the interests of productivity. Since the beads are also compressible, entrapped yeast bioreactors are usually operated with the process flow directed in a vertically upward direction. Beads with very low mechanical strength can be disrupted by the evolution of gas bubbles and retention of yeast is comparatively poor.

Yeast cells can be attached to inert surfaces such as wood chips, ceramics, glass, cellulose, stainless steel and various resins (Godia *et al.*, 1987; Ryder *et al.*, 1995). The

mechanism of attachment is via a combination of electrostatic and hydrophobic binding (Mozes *et al.*, 1987). For brewing applications the use of DEAE cellulose has found favour. This material is described as granulated derivatized cellulose (GDC) and is sold under the trade name Spezyme[®] (Cultor Finland). The beads have a diameter of 0.4–0.8 mm and are capable of bearing a yeast loading of 500×10^6 cells per g wet weight of carrier. Following prolonged use the beads can be regenerated by treatment with NaOH (2% w/v) at 80 °C (Pajunen, 1995).

Colonization of porous materials is a combination of entrapment and surface binding. Several types of support have been used, the most promising of which are glass beads (SIRAN[®], Schott Engineering Company, Mainz, Germany) and ceramic rods containing a matrix of silicon carbide. The former consists of beads with a diameter of 1–3 mm prepared from a mixture of glass powder and salt. After the beads are manufactured the salt is dissolved to leave pores of 60–300 μm diameter. The proportion of each bead which is pore accounts for approximately 60% of the total. This gives biomass loadings of approximately 15×10^6 cells per g bead (Breitenbucher and Mistler, 1995). Ceramic cylinder supports have been described by Krikilion *et al.*, (1995). Each cylinder element contains channels through which the process liquid flows. The channels pass through a porous silicon carbide matrix. The surface pores of the matrix are approximately 8–30 μm in diameter and internal pores have a diameter of 100–150 μm . The small outer pores allow entry of yeast cells, which then grow and colonize the comparatively larger lumen. Both glass and ceramic supports are incompressible and so there is little restriction on the flow rates that can be used. They can be used in reactors with upward or downward flow. Similarly, the robustness of the materials protects them from damage due to CO₂ evolution. On the other hand, because cells penetrate into the supports, they are more difficult to clean for regeneration purposes.

All immobilized reactor systems have a finite life, which is limited by the gradual build-up of debris and deterioration of the support and the yeast population. The duration of the lifespan and the ease and cost of regeneration are important considerations when making a choice of support and reactor. Comparatively expensive support materials such as glass beads and ceramics require treatment with hot NaOH or an oxidizing agent such as hydrogen peroxide, followed by steam sterilization. Relatively inexpensive supports such as alginate beads or wood chips can be discarded after a single use.

Immobilization influences yeast physiology. From the standpoint of the brewing process some of the effects are beneficial others are not. Several reports describe enhanced rates of glycolysis and ethanol formation in immobilized cells compared to freely suspended cells (Galazzo and Bailey, 1989, 1990; Aires Barros *et al.*, 1987). In contrast, rates of growth, as measured by biomass increase are reduced in the case of immobilized cells. In one report (Aires Barros *et al.*, 1987) the rate of ethanol formation in an immobilized system was 50% greater than that of the same concentration of freely suspended cells, but the biomass yield was reduced by 30% and there were increases in trehalose and glycogen reserves in immobilized cells. These observations suggest that the immobilized yeast cells enjoy a protected environment in agreement with the finding that they exhibit an increased tolerance to ethanol (Holcberg and Margalith, 1981). This is in accord with the assertion that micro-organisms in nature usually grow in association on surfaces, as in biofilms (Section 17.7.1).

Adverse effects on yeast due to immobilization are probably related to the effects of restricted transfer of solutes. Immobilized systems involving colonization of surfaces or in polymeric beads provide a continuum of environments from surface to core. Cells that are buried deep in the matrix of the bead commonly exhibit morphological abnormalities

such as pleomorphism, increased ploidy and failure of daughter cells to separate (Aires Barros *et al.*, 1987; Koshcheyenko *et al.*, 1983). These cells are likely to be subjected to very hostile conditions, such as starvation, anaerobiosis, reduced water activity, high ethanol concentration and high dissolved CO₂. Attachment to surfaces may, in some way, disrupts the cell cycle. With carriers that rely on binding of cells to surfaces, morphological abnormalities are less common. This suggests that mass transfer has the greatest influence. Whatever the precise reason it explains the low growth rate that is characteristic of immobilized systems.

The fact that immobilized systems function as biocatalysts where there is very limited growth is both a strength and a weakness. They are most suitable for use in processes where limited metabolism is required. Thus, they have been widely used for the production of low-alcohol beers by limited fermentation and for continuous diacetyl removal. In the first instance, ethanol formation can be discouraged by the use of a combination of low temperature and anaerobiosis (Breitenbucher and Mistler, 1995; van de Winkel *et al.*, 1991). Debourg *et al.*, (1994) demonstrated that immobilized yeast was as effective at removing wort carbonyls as freely suspended cells. Diacetyl removal is accomplished by passing green beer, ex-primary fermenter through a reactor containing immobilized yeast (Pajunen and Gronquist, 1994). The high concentration of yeast removes diacetyl very rapidly. It is necessary to heat green beer (c. 10 min. at 90 °C; 194 °F) prior to passage through the bioreactor to ensure that all precursor α -acetolactate is converted to diacetyl.

The strictures that apply to the application of continuous processes to primary fermentation also hold for immobilized systems. Limited yeast growth and the need for ordered assimilation of metabolites to produce balanced quantities of flavour metabolites are problematic. In most cases the option of using series of multiple tanks of immobilized yeast has been adopted in order to physically separate the process stages occurring in conventional batch fermentation. A fuller description of prototype and commercial immobilized yeast reactors used in brewing may be found in Boulton and Quain (2001).

13.9 Growth on solid media

In the majority of immobilized yeast systems the cells grow attached to inert surfaces. In this situation the cells obtain nutrients from the surrounding liquid medium and the surface merely forms a substrate for attachment. An alternative growth habit is that of yeast growing on the surface of nutrient media solidified with either agar or gelatin. Yeast cells multiply and form masses, termed colonies, on the surface of the medium. Colonies are roughly circular viewed from above and dome shaped in section. Colony sizes range from 1×10^7 cells to more than 10^9 cells depending on the number per plate. The precise shapes of the colonies are often characteristic of individual strains and are used as an aid to identification. In brewing, the shape and colours of colonies that form on general-purpose media such as Wallerstein Laboratory nutrient agar, can be used to check strain purity (Section 17.3.6). As discussed later, the giant colony technique is a traditional method for brewing yeast strain differentiation.

The pattern of growth on solid media by yeast is a function of the genotype of the particular strain and how the cells respond to the available nutrients. The kinetics of colonial growth has been studied by Kamath and Bungay (1988). The colony increases in size at the periphery and in height. The rate of peripheral growth is linear and not exponential. It can be expressed by the following equation:

$$rt = K_{rt} + r_0$$

Where, rt is the linear radial growth rate, K_{rt} is the radial growth rate constant, r_0 is the radius at zero time, r is the colony radius at time t .

In the giant colony technique, yeast is grown on wort medium solidified with gelatin. Plates are incubated for 3–6 weeks at temperatures of 15–18 °C; 59–69.4 °F (Hall, 1954). Several characteristics of colonies may be of diagnostic significance. Colonies are described as being matt or shiny. The profiles of colonies viewed in section and from above may be simple or very complex. Variations in the peripheral margins of colonies include smooth circular, fringed, irregular and lobate. The surfaces of colonies range from smooth to concentric or radial striated and deep radial valleyed types. Variations in colonial profiles include convex, flat, with a central dome, wrinkled and crateriform. The variety of colonial morphologies implies that the mass of cells is heterogeneous. This is predictable in that cells in the growing colony do not all have equal access to nutrients in the medium and to oxygen. The variety of responses to these inequalities in nutrient supply explains the characteristics of colonial morphology. For example, the formation of a fringe around the margin of a colony is a dimorphic response in which cells at the margins adopt a pseudomycelial form. This may represent a mechanism by which peripheral cells extend the area over which they are able to assimilate nutrients. Other shapes represent the response of individual cells within the developing colony to greater or lesser concentrations of nutrients and metabolic by-products. Colonies are highly organized structures. A gene, given the name *IRRI*, has been isolated that has no known role in cells growing suspended in liquid media but is required for colony formation on solid substrates (Kurlanzka *et al.*, 1999). As with the case of biofilms it is highly likely that colonies represent a strategy in which the population ensures survival by co-operative behaviour.

13.10 Yeast identification

The taxonomy of yeast, including brewing strains is discussed in Chapter 11 (Section 11.2). The methods used for the cultivation of yeast for the purposes of identifying contaminants are described in Chapter 17 (Sections 17.3.5; 17.3.6). Here the methods used for the differentiation of brewing yeasts are described. Methods are roughly divisible into two groups, the traditional and the modern. Traditional methods are often based on conventional microbiological techniques. They rarely have taxonomic significance but have evolved within individual breweries to meet the need for identification and differentiation of proprietary brewing yeast strains. Modern techniques frequently have taxonomic significance. Usually they have been developed within academic research organizations and are not specifically targeted at brewing. Commonly they use sophisticated and costly apparatus. Traditional approaches are still used to avoid the cost and requirement for skilled operatives needed for many modern techniques. Modern methods may be used in confirmatory tests by third parties. However, the use of molecular genetic analyses is becoming more commonplace and inexpensive. These may soon be seen as the methods of choice for routine brewery QA testing.

13.10.1 Microbiological tests

Plating microbiological samples on solid nutrient media is routinely used for enumerating microbial populations. By using selective or chromogenic media the method can have diagnostic significance. The method most widely used for differentiating brewing from

wild strains relies on the ability of the latter to grow in the presence of inhibitors such as Cu^{2+} or the antibiotic cycloheximide (Section 17.3.6). General-purpose media such as WLN help in the differentiation of brewing strains. WLN contains the indicator dye bromocresol green and this causes yeast colonies to take on a variety of shades of green. The particular shade of colouring is characteristic of some but not all strains. The plates must not be overloaded. The method needs a skilled practitioner with experience of the yeast strains being examined. The use of giant colony morphology is described in Section 13.8. The requirement for several weeks' incubation reduces its usefulness.

Differentiation of lager and ale colonies can be accomplished by plating out onto a medium containing 5-bromo-4-chloro-3-indoyl- α -D-galactoside, known as X- α -Gal (Tubb and Liljeström, 1986). Lager, but not ale, strains contain α -galactosidase which cleaves the chromogenic substrate to give a product which forms a blue precipitate. Colonies of ale yeasts remain colourless whereas lager types assume a blue colour.

13.10.2 Biochemical tests

Several tests have been developed, which probe the biochemical properties of individual yeast strains. Many of these tests are part of the standard armoury of the microbiologist. There is some overlap with the methods discussed in the previous section. Other techniques probe aspects of biochemistry that are more directly relevant to brewing performance.

The ability of an organism to utilize selected carbon sources under aerobic conditions (assimilation) or anaerobic conditions (fermentation) has been widely used as a method of differentiation and identification. Several techniques based on this approach are used. They share in common the assessment of growth on a basal nutrient media supplemented with a variety of carbon sources. Basal media include peptone water and yeast nitrogen base (Section 17.3.6). Liquid media require the use of pure cultures, frequently indicator dyes are included and a trap for detecting any CO_2 formed. Solid media are also usually inoculated with pure cultures. However, with replica plating (Section 17.3.6) it is possible to assess mixed populations. Commercial kits are available for identifying particular groups of micro-organisms, both bacteria and yeast (for example, API test kits, bioMérieux, Marcy-l'Etoile, France). These take the form of strips containing wells each of which is filled with a basal medium and a supplement of a different carbon source. After inoculation and incubation, growth is indicated by the change in colour of an indicator dye. As with many of the general microbiological approaches, these methods are best suited to identifying wild yeast strains. One assimilation test does have value. Since lager strains possess α -galactosidase and ale strains do not, the former are able to hydrolyse melibiose and grow on the released sucrose and galactose.

Strain identification can be based on assessment of performance in laboratory wort fermentations. This approach is of obvious value since it assesses the properties that will be exhibited during use in the brewery. In this respect, many of the tests are of the trueness-to-type variety. Whilst these may not have taxonomic significance they are a useful means of checking for strain drift. Several pieces of equipment have been designed for carrying out laboratory fermentations. These range from small (100 ml) stirred hypovials (Quain *et al.*, 1985) through to larger stirred fermenters with facilities for controlling headspace gas. The most commonly used piece of apparatus is the EBC tall tube. These are tempered glass or stainless steel tubes with a capacity of two litres and a high aspect ratio (150 cm \times 5 cm diameter) supposedly reflective of a fermenter. They are usually used in banks of several tall tubes to permit simultaneous fermentations.

Automated versions are available, some of which are fitted with devices for automated sampling and data acquisition (Sigsgaard and Rasmussen, 1985; Skands, 1997). Fermentation performance in tall tubes is assessed by five criteria; formation of a yeast head, formation of a yeast sediment, attenuation rate, degree of attenuation and clarification after fining.

Laboratory fermentations can be used to assess other growth-related properties of yeast. For example, the effect of varying temperature. Thus, ale strains on average have higher maximum growth temperatures (37–40 °C; 98.6–104 °F) compared with lager strains (31.5–34 °C; 88.7–93.2 °F) (Walsh and Martin, 1977). The oxygen requirement needed for satisfactory fermentation performance varies between individual yeast strains (Section 12.6). Pitching aliquots of wort containing varying dissolved oxygen concentration then observing subsequent fermentation performance can assess this property.

13.10.3 Tests based on cell surface properties

The surface properties of yeast cells underpin two types of differentiating tests. These are firstly, those that assess the immunological properties of cells and, secondly, those that measure flocculation.

Immunological analyses rely on interactions between antigens (the yeast cell or fraction thereof) and antibodies. The latter are obtained by prior inoculation of the antigen fraction into a suitable mammalian host, usually a rabbit. Antibodies are raised in response to the antigen and these can be isolated and purified. Components of the yeast cell wall, principally mannan side chains, have antigenic activity (Section 11.6.1). Reactions between antigens and antibodies are specific. The complexes formed can be visualized by coupling a fluorescent molecule to the antibody. A much-used method is the ELISA technique (enzyme-linked immuno-absorbent assay), in which a membrane is coated with a layer of antibody, which is reactive with the antigen of interest. The antigen mixture is added to the membrane. The membrane is then washed, which removes all but the bound antigen. The complex is then treated with a second batch of antibody, the same as that attached to the membrane, although in this case it is conjugated with an enzyme. The second antibody fraction binds to the antigen-antibody complex. After a second wash to remove unbound antibody, a substrate is added, which is acted upon by the enzyme and in doing brings about a colour change. This colour change allows visualization and quantification of bound antigen.

Methods of assessing yeast flocculence have a long history. They cannot be used to provide a positive identification but are useful nonetheless for assurance that yeast strains are behaving normally. Four methods have gained acceptance within the brewing industry. These are the procedures of Burns (Burns, 1941), Gilliland (1951), Hough (1957) and Helms (Helms *et al.*, 1953). Of these only the Gilliland and Helms methods remain in common use. The Hough method tests for flocculation of aliquots of washed cells suspended in a solution of calcium chloride adjusted to pH 3.5 or pH 5.0. Yeast strains are classified based on whether flocculation occurs under these conditions. If yes, does addition of maltose disperse flocs? If no, does addition of ethanol result in flocculation? If no, does the addition of addition of a second yeast strain (NCYC 1108) result in co-flocculation. In the Helms method a sample of pitching yeast is washed by suspension and centrifugation in a solution of calcium sulphate. The washed yeast is re-suspended in calcium sulphate adjusted to pH 4.5 in a graduated centrifuge tube. After incubation at 20 °C for 20 minutes flocculation is assessed based on the volume of sediment formed.

Both the Burns and Gilliland procedures assess the occurrence of flocculation after yeast is recovered from laboratory wort fermentations. In the Burns procedure, the extent of floc formation is recorded when the yeast is suspended in beer, distilled water and acetate buffer, pH 4.6. In the Gilliland method yeast is grown on agar medium to obtain separate colonies. Fifty colonies are picked off the plate and each is inoculated into 5 ml trub-free hopped wort. After three days static incubation, at 27°C, each culture is examined for the formation of sediment. After pouring off all but 0.5 ml of the liquid the yeast is gently agitated and examined. Gilliland classified yeast into four groups on the basis of their flocculence characteristics. Class I types were completely dispersed throughout. Class II yeast sediment towards the end of the incubation. The sediment is granular in appearance when re-suspended. Class III types behave similarly to the Class II but the sediment is more difficult to re-suspend and forms large flakes. Class IV yeast sediments very early in the growth phase. The sediment re-suspends to form loose flakes.

13.10.4 Non-traditional methods

Several methods for differentiating yeast strains are relatively new at the time of writing. They fall into two broad groups. Firstly, those which are based on an analysis of cell composition and, secondly, those which probe the genome of the cell. Methods based on cellular composition rely on whole cell analyses, for example, pyrolysis mass spectrometry and Fourier transform infra-red spectroscopy. Alternatively, specific sub-cellular fractions can be extracted and analysed, for example proteins and lipids. Methods for strain differentiation based on cell composition require that the yeast has been cultivated under defined conditions in order to eliminate differences due to variations in physiological state. Genetic analyses have the advantage that the composition of the genome is relatively constant and independent of physiological state.

Pyrolysis gas chromatography and pyrolysis mass spectrometry rely on heating a sample of biomass in an inert atmosphere to around 550°C (1022°F). This causes the cells to decompose into a mixture of low molecular weight volatile fragments (Goodacre, 1994). The fragments are separated using gas chromatography or the more powerful technique of gas chromatography mass spectrometry (GC-MS). The pattern of fragments that are generated are characteristic for individual or closely related groups of strains (Timmins *et al.*, 1998). Fourier transform infra-red spectroscopy provides a fingerprint of whole cells by measuring the interactions between infra-red radiation and intracellular components such as nucleic acids, proteins, membranes and cell wall polysaccharides. For microbial cells, the mid-IR range (4000–400 cm⁻¹) provides the best resolving power. The method is capable of distinguishing bacteria at the strain level (Helm *et al.*, 1991). The method has been successfully used for differentiating brewing yeast strains (Timmins *et al.*, 1998). The proteome of cells can be extracted and separated by electrophoresis and visualized using techniques such as Western blotting. Based on differences in genotype it would be predicted that proteome analyses would be different for individual strains and therefore of taxonomic significance. This has been verified in a study of 29 enological strains of *S. cerevisiae* (van Vuuren and van der Meer, 1987). Total fatty acids can be extracted from yeast using a solvent such as a mixture of chloroform and methanol. In the form of methyl esters, the mixture of fatty acids can be separated using capillary gas liquid chromatography. The spectrum of fatty acid methyl esters and their relative abundance has been used to differentiate 13 strains of *S. cerevisiae* (Augustyn and Kock, 1989).

The most precise methods for strain differentiation are those based on analysis of the nucleic acids of the genome. These methods generate so-called genetic fingerprints (Chapter 11; Section 11.8.1). Yeast strains can be positively identified and differentiated using restriction fragment polymorphism (Schofield *et al.*, 1995), polymerase chain reaction (de Barros *et al.*, 1998) and karyotyping (Casey, 1996).

13.11 Measurement of viability

Viability of micro-organisms is usually defined as the ability to reproduce. This is a useful parameter to determine since it provides a predictive measure of the ability of yeast to reproduce when pitched into wort. In traditional microbiology, viability is assessed by plating out serial dilutions of suspension of cells onto a suitable medium. Each colony that develops after incubation is assumed to have derived from a single cell, therefore the colony count is directly related to the number of viable cells in the original suspension. Using this approach the viable cell concentration is usually expressed as the number of colony forming units (cfu). The colony counting procedure takes several days to obtain a result. There is a rapid version of the test in which micro-colonies are allowed to grow on nutrient agar poured into a well in a specially designed microscope slide. The micro-colonies can be counted using a microscope. This reduces the time taken to obtain a result from days to several hours. Even using the rapid method, colony-counting techniques are too slow to be used to support decisions regarding the fitness of yeast to be pitched. Rapid methods for the determination rely on the use of vital stains. These are dyes which are excluded from viable cells but not dead ones. Alternatively, they may be taken up by all cells and subject to metabolic modification by living cells. The latter is accompanied by a colour change. Several dyes have been used to assess viability. Some of these, together with their mode of action are shown in Table 13.2.

The most used method for the assessment of yeast viability in breweries employs methylene blue and a haemocytometer counting chamber (EBC *Analytica Microbiologica*, 1992). The haemocytometer consists of a glass microscope slide, which contains two chambers of known volume. The bases of the chambers are divided into a number of small squares to form a grid which facilitates counting. To determine viability a suitable dilution of yeast slurry is mixed with an equal volume of a solution of methylene blue and placed into the haemocytometer. Viable cells take up methylene blue and reduce the dye to the colourless leuco form. Dead cells cannot reduce the dye and stain blue. The relative proportions of colourless and blue cells are counted and by calculation the total and viable yeast count in the slurry is determined.

Compared to plate counts, the methylene blue method overestimates viability. While at values greater than 90% agreement is reasonable, the disparity becomes increasingly marked the lower the true viability (Parkinen *et al.*, 1976). It has been suggested that other dyes are more reliable than methylene blue. In one study, methylene blue (with Safranin O counterstain), citrate methylene blue, alkaline methylene blue, citrate methylene violet and alkaline methylene violet were compared with plate count determinations of viability (Smart *et al.*, 1999). A variety of strains were tested in various physiological conditions ranging from exponential phase, through stationary phase, starved and heat-killed. It was concluded that citrate methylene violet produced the most reliable results. Nevertheless, methylene blue continues to be used widely. Providing the analysis is performed by a skilled operator and the viability of the yeast is greater than c. 80% it provides a reliable result. Counting cells stained with dyes can be automated to

Table 13.2 Methods for measuring yeast viability

Method	Mechanism	Ref.
Methylene blue staining	Viable cells reduce dye to colourless form, dead cells stain blue	[1]
Methylene blue with Safranin O counterstain	Counterstain reportedly improves contrast between live and dead cells and possibly differentially stains stressed cells	[2]
Fluorescein diacetate	Esterases in viable cells cleave molecule to release fluorophor, fluorescein	[3]
Bis(1,3-dibutylbarbituric acid trimethine oxonol) [DiBAC ₄]	Anionic dye excluded by viable cells, non-viable cells are fluorescent	[4]
Propidium iodide (+ fluorescein diacetate)	Excluded by live cells, stains dead cells red by binding to DNA. With counterstain, viable cells are fluorescent green	[5]
ChemChrome Y	Taken up by viable cells and cleaved enzymically to release fluorophore	[6]
Mg 1-aniline-8-naphthalene sulphonic acid (Mg-ANS)	Fluorophore only taken up by viable cells where it binds to proteins	[7]
2-[N-(7-nitrobenz-2-oxa-1,3-diazol-4-yl) amino]-2-deoxyglucose (2NBDG)	Fluorescent derivative of glucose only taken up by viable cells	[8]
Rhodamine 123	Cationic fluorophore taken up by viable cells with functional oxidative mitochondria. Not useful for viability measurement of anaerobic repressed yeast	[9]

[1] IOB *Methods of Analysis*, 1997; [2] Jones, 1987; [3] Chilver *et al.*, 1978; [4] Dinsdale *et al.* 1999; [5] Lloyd and Hayes, 1995; [6] Deere *et al.*, 1998; [7] McCaig, 1990; [8] Oh and Matsuoka, 2002; [9] Dinsdale and Lloyd, 1995.

remove human error, for example, with electronic image analysis (Raynal *et al.*, 1994). The radiofrequency permittivity biomass meter described in Section 13.2 is responsive only to the viable fraction of yeast slurries. Since it does not respond to the non-viable fraction it does not provide a measure of viability. A prototype modified laboratory version is described in (Boulton *et al.*, 2001) which uses a combination of radiofrequency permittivity and a fluorescent vitality stain to detect both viable and non-viable yeast cells. Should this become available commercially it would allow automatic measurement of viability.

Flow cytometry has been used for viability determinations. This apparatus forces a suspension of yeast through a small nozzle such that the cells form a single-file stream. The cells are counted by passage through a laser beam. In addition, devices of various types are provided for the detection of cells stained with specific dyes, most usually fluorescent types such as fluorescein diacetate (Lloyd, 1993; Bouix and Leveau, 2001). The procedure gave a good correlation between fluorescent staining and a plate counting technique. Unfortunately, flow cytometers are costly and not likely to find routine use in any but the most lavishly appointed routine quality assurance laboratories. However, the instruments are capable of much more than simple measurement of viability as discussed in the following section.

13.12 Assessment of yeast physiological state

The results of viability tests are used for the calculation of the quantity of yeast to be added to wort to achieve a desired pitching rate. They are also used to assess the quality of yeast. Typically, an arbitrary value is chosen, usually around 90%, below which the yeast is considered unfit for use. The assumption is made that if yeast viability is low then the viable fraction is probably stressed. In recent years, a number of additional tests have been proposed that seek to probe the physiological state of the viable fraction of yeast populations. These are 'vitality tests' (Lentini, 1993). The rationale behind the need for these tests is that current fermentation practice exposes yeast to a plethora of influences, which together have the potential to influence yeast physiology in perhaps unexpected ways. These influences have been comprehensively reviewed by Heggart *et al.* (1999). They include environmental effects such as osmotic stress, barometric stress, oxidative stress, mechanical stress, pH effects and temperature. These are coupled with genetic effects such as mutation and growth-related effects such as yeast cell ageing. In addition, nutritional effects including starvation, effect of oxygen, CO₂ and ethanol. These effects in combination have the potential to influence yeast physiology in ways that affect subsequent fermentation performance. Variable yeast physiology is not detected by viability tests.

It is argued that to assess the cumulative effects of these influences on yeast it is necessary to use methods which are more discriminating than simple differentiation between viable and non-viable. The results of these tests may be used as the basis of a simple decision to use or discard yeast. Preferably they provide a result that is predictive of fermentation performance and they should identify appropriate values for parameters such as pitching rate and wort dissolved oxygen concentration that will provide optimum fermentation performance and consistent beer analysis. Several types of vitality test have been suggested which assess different aspects of yeast composition and biochemical function.

The most relevant measures of yeast condition are those that directly reflect the changes that occur during fermentation. It is possible to perform laboratory fermentations

to predict performance at production scale, however, this is too time consuming to be of value. Rapid tests, which have been suggested, include measures of the rates of uptake of oxygen, uptake of glucose, evolution of CO₂, ethanol formation and exothermy. Apparatus has been described that is capable of measuring some of these parameters. For example, the Bri vitality apparatus consists of an attemperated incubation chamber fitted with an integral dissolved oxygen probe (Kennedy, 1989). Providing a known concentration of yeast is placed within the chamber it is possible to measure specific rates of oxygen uptake. These are related to yeast sterol content and by implication provide a measure of the optimum oxygen requirement for efficient fermentation performance (Boulton and Quain, 1987). Similar apparatus for measuring specific rates of CO₂ evolution has been described (Muck and Narziss, 1988).

The acidification power test measures the ability of yeast to acidify the medium both spontaneously (AP1) and in response to the addition of glucose (AP2) (Kara *et al.*, 1988). Acidification occurs in response to proton extrusion and reflects the activity of plasma membrane H⁺ ATPase. Maintenance of transmembrane potential requires metabolic activity, therefore the magnitude of AP1 reflects the availability of storage carbohydrates. AP2 is fuelled by exogenous glucose and is indicative of glycolytic flux. The results of the acidification test as applied to pitching yeast correlate with subsequent fermentation performance (Fernandez *et al.*, 1991; Mathieu *et al.*, 1991; Siddique and Smart, 2000).

The acidification power test has been subject to several modifications. In one (Patino *et al.*, 1993) maltose was substituted with glucose based on the fact that this is the major sugar component of wort. These authors suggested that the changes should be assessed either via the measure of conductance, or as cumulative acidification power – the sum of changes in proton concentration over the course of the test. In another approach (Isenrentant *et al.*, 1996) the amount of sodium hydroxide required to maintain a constant pH was determined. This was claimed to avoid the limitations of the standard method when using very high-vitality yeast.

Several cell components, for example glycogen, trehalose and sterol, vary in concentration in response to changes in physiological condition. The concentrations of many of these cell components are known to be influential on fermentation performance. Variation from the norm in the concentrations of some of these cellular components is indicative of inappropriate yeast management.

Metabolism is driven by the energy released by hydrolysis of ATP. The energy status of the cell is defined as the adenylate energy charge, which relates the relative concentrations of AMP, ADP and ATP (Chapman and Atkinson, 1977). The concentrations of these metabolites can be measured using bioluminescence (Section 17.3.1). The approach can be expanded to include the concentration of inorganic phosphate by nuclear magnetic resonance. Thereby, phosphorylation potential can be determined. Intracellular concentrations of glycogen and sterol are related to oxygen requirements in fermentation (Boulton and Quain, 1987). Low concentrations of glycogen in pitching yeast are indicative of prolonged storage. Coupled with high sterol concentration, low glycogen is indicative of exposure to oxygen. Both metabolites can be determined by simple rapid tests. For example, glycogen by staining with iodine (Quain, 1981) and sterol by a spectrophotometric procedure using the polyene antibiotic, filipin (Rowe *et al.*, 1991). Of these, determination of glycogen appears to be the most informative, particularly as an indicator of stressed yeast. The latter condition is associated with the presence of elevated concentrations of trehalose (12.5.7). Trehalose concentration can be rapidly determined by infra-red reflectance spectroscopy (Moonsamy *et al.*, 1996).

Many aspects of cellular composition and physiological state are amenable to investigation using staining techniques. In particular, using biological fluorescent stains in conjunction with flow cytometry (Edwards *et al.*, 1996; Lloyd and Dinsdale, 2000). Choice of an appropriate stain allows measurement of intracellular pH, glycogen concentration, geneological age, ploidy, membrane competence, budding index and phase in cell cycle. The cost of flow cytometers continues to ensure that they are largely confined to research laboratories. Nevertheless, it is a very powerful technique and no doubt widespread adoption in quality assurance laboratories will be accompanied by a reduction in price.

13.13 References

- AIRES BARROS, M. R., BARROS, M. R., CABRAL, J. M. S. and NOVAIS, J. M. (1987) *Biotechnol. Bioeng.*, **24**, 1097.
- ASHURST, K. (1990) *Brew. Dist. Internat.*, **21**, 28.
- AUGUSTYN, O. P. H. and KOCK, J. F. L. (1989) *J. Microbiol. Meth.*, **10**, 9.
- BAMFORTH, C. W., BOULTON, C. A., CLARKSON, S. P. and LARGE, P. J. (1988) *Proc. 20th Conv., Institute of Brewing (Australia and N. Zealand Section), Brisbane*, 209–218.
- BARFORD, J. P. (1987) 'The Technology of Aerobic Yeast Growth'. In *Yeast Technology*, D. R. Berry, I. Russell and G. G. Stewart, eds, pp. 200–230, Allen & Unwin, Hemel Hempstead, UK.
- BARKER, M. G. and SMART, K. A. (1996) *J. Amer. Soc. Brew. Chem.*, **54**, 121.
- BOUIX, M. and LEVEAU, J.-Y. (2001) *J. Inst Brew.*, **107**, 217.
- BOULTON, C. A. and CLUTTERBUCK, V. J. (1993) *Proc. 24th Cong. Eur. Brew. Conv., Oslo*, 509.
- BOULTON, C. A. and QUAIN, D. E. (1987) *Proc. 21st Cong. Eur. Brew. Conv., Madrid*, 401.
- BOULTON, C. A. and QUAIN, D. E. (1999) *Proc. 27th Cong. Eur. Brew. Conv., Cannes*, 647.
- BOULTON, C. A. and QUAIN, D. E. (2001) *Brewing Yeast and Fermentation*, Blackwell Science, Oxford.
- BOULTON, C. A., MARYAN, P. S., LOVERIDGE, D. and KELL, D. B. (1989). *Proc. 22nd Cong. Eur. Brew. Conv., Zurich*, 653.
- BOULTON, C. A., BOX, W. G., CARVELL, J. and TURNER, K. (2001) *Proc. 28th Cong. Eur. Brew. Cong., Budapest*, 722.
- BRANDL, J. (1996) *Brauwelt Internat.*, **14**, 32.
- BREITENBUCHER, K. and MISTLER M. (1995) *Proc. EBC Monograph, XXIV, Espoo*, 77.
- BURNS, J. A. (1941) *J. Inst. Brew.*, **47**, 10.
- CAHILL, G. and MURRAY, D. M. (2000) *J. Amer. Soc. Brew., Chem.*, **58**, 14.
- CASEY, G. P. (1996) *MBAA Tech. Quart.*, **33**, 1.
- CHAPMAN, A. G. and ATKINSON, D. E. (1977) *Adv. Microb. Physiol.*, **15**, 253.
- CHILVER, M. J., HARRISON, J. and WEBB, T. J. B. (1978) *J. Amer. Soc. Brew. Chem.*, **36**, 13.
- DEANS, K., PINDER, A., CATLEY, B. J. and HODGSON, J. A. (1997) *Proc. 26th Cong. Eur. Brew. Conv., Maastricht*, 469.
- DE BARROS LOPES M., SODEN, A., MARTENS, A. L., HENSCHKE, P. A. and LANGRIDGE, P. (1998) *Int. J. Systematic Bacteriol.*, **48**, 279.
- DEBOURG, A. and VAN NEDERVELDE, L. (1999) *Proc. 27th Cong. Eur. Brew. Conv., Cannes*, 751.
- DEBOURG, A., LAURENT, M., GOOSENS, E., BORREMANS, F., VAN DER WINKEL, L. and MASSCHELEIN, C. A. (1994) *J. Amer. Soc. Brew. Chem.*, **52**, 100.
- DEERE, D., SHEN, J., VESEY, G., BELL, P., BISSINGER, P. and VEAL, D. (1998) *Yeast*, **14**, 147.
- DINSDALE, M. G. and LLOYD, D. (1995) *J. Inst. Brew.*, **101**, 453.
- DINSDALE, M. G., LLOYD, D., MCINTYRE, P. and JARVIS, R. (1999) *Yeast*, **15**, 285.
- EBC ANALYTICA MICROBIOLOGICA (1992) *Vol. II, Method 3.1.1.2*.
- EDWARDS, C., PORTER, J. and WEST, M. (1996) *Ferment*, **9**, 288.
- ERNANDES, J. R., WILLIAMS, J. W., RUSSELL, I. and STEWART, G. G. (1993) *J. Amer. Soc. Brew. Chem.*, **51**, 16.
- FELS, S., RECKELBUS, B. and GOSSELIN, Y. (1999) *Proc. 7th IOB Conv. (Africa Section) Nairobi*, 147.
- FERNANDEZ, S. S., GONZALEZ, G. and SIERRA, J. A. (1991) *MBAA Tech. Quart.*, **28**, 89.
- FUGE, E. K., BRAUN, E. I. and WERNER-WASHBURNE, M. (1994) *J. Bacteriol.*, **176**, 5802.
- GALAZZO, J. L. and BAILEY, J. E. (1989) *Biotechnol. Bioeng.*, **33**, 1283.
- GALAZZO, J. L. and BAILEY, J. E. (1990) *Enz. Microb. Technol.*, **12**, 162.
- GEIGER, E. (1993) *Brauwelt Internat.*, **11**, 430.
- GERVAIS, P., MARCHAL, P. A. and MOLIN, P. (1992). *Biochim., Biophys., Acta*, **40**, 1435.
- GILLILAND, R. B. (1951) *Proc. 3rd Cong. Eur. Brew. Conv., Brighton*, 35.
- GODIA, F., CASAS, C. and SOLA, C. (1987) *Proc. Biochem.*, April, 43.

- GOODACRE, R. (1994) *Microbiol. Europe*, **2**, 16.
- GULDFELDT, L. U. and PIPER, J. U. (1999) *MBAA Tech. Quart.*, **36**, 1.
- HALL, J. F. (1954) *J. Inst. Brew.*, **60**, 482.
- HARRIS, C. M., TODD, R. W., BUNGARD, S. J., LOVITT, S. J., MORRIS, J. G. and KELL, D. B. (1987) *Enz. Microbiol. Technol.*, **9**, 181.
- HAYFLICK, L. (1965) *Expt. Cell Res.*, **37**, 614.
- HEGGART, H. M., MARGARITIS, A., PILKINGTON, H., STEWART, R. J., DOWHANICK, T. M. and RUSSELL, I. (1999) *MBAA Tech. Quart.*, **36**, 383.
- HELM, D., LABISCHINSKI, H., SCHALLEHN, G. and NAUMANN, D. (1991) *J. Gen. Microbiol.*, **137**, 69.
- HELMS, E., NOHR, B. and THORNE, R. S. W. (1953) *Wallerst. Lab. Commun.*, **16**, 115.
- HOLCBERG, I. B. and MARGALITH, P. (1981) *Eur. J. Appl. Microbiol., Biotechnol.*, **13**, 133.
- HOUGH, J. S. (1957) *J. Inst. Brew.*, **63**, 483.
- HOUGH, J. S., BRIGGS, D. E., STEVENS, R. and YOUNG, T. W. (1982) *Malting and Brewing Science*, Vol. 2., *Hopped Wort and Beer*, (2nd edn), Chapman and Hall, London and New York.
- IOB METHODS OF ANALYSIS (1997) Vol. 2, *Microbiology*, Inst. Brew., Clarges St., London.
- ISENRENTANT, D., GREENANS, W. and VERACHTERT, H. (1996) *J. Am. Soc. Brew. Chem.*, **54**, 110.
- JAZWINSKI, S. M. (1999) *Expt. Gerontology*, **34**, 1.
- JONES, R. P. (1987) *Proc. Biochem.*, **22**, 130.
- KAMATH, R. S. and BUNGAY, H. R. (1988) *J. Gen. Microbiol.*, **134**, 3061.
- KARA, B. V., SIMPSON, W. J. and HAMMOND, J. R. M. (1988) *J. Inst. Brew.*, **94**, 153.
- KENNEDY, R. (1989) *Brew. Guard.*, Sept, 57.
- KIRSOP, B. E. (1991) 'Maintenance of yeasts'. In *Maintenance of Microorganisms and Cultured Cells, A Manual of Good Practice*, 2nd edn, B. E. Kirsop and A. Doyle, eds, pp. 161–182, Academic Press, London.
- KOSHCHEYENKO, K. A., TURKINA, M. V. and SKRYABIN, G. K. (1983) *Enz. Microb. Technol.*, **5**, 14.
- KRIKILION, P. H., ANDRIES, M., GOFFIN, O., VAN BEURAN, P. C. and MASSCHELEIN, C. A. (1995) *Proc. 25th Cong. EBC, Brussels*, 419.
- KURLANZKA, A., RYTKA, J., ROZALSKA, B. and WYSOCKA, M. (1999) *Yeast*, **15**, 23.
- LENTINI, A. A. (1993) *Ferment*, **6**, 321.
- LLOYD, D. (1993) *Flow Cytometry in Microbiology*, D. Lloyd ed., Springer Verlag, Berlin.
- LLOYD, D. and DINDALE, G. (2000) 'From bright field to fluorescent and confocal microscopy'. In *Brewing Yeast Fermentation Performance*, K. A. Smart, ed., pp. 3–9, Blackwell Science, Oxford.
- LLOYD, D. and HAYES, A. J. (1995) *FEMS Microbiol. Lett.*, **133**, 1.
- MADEO, F., FROHLICH, E. and LIGER, M. (1999) *J. Cell Biol.*, **145**, 757.
- MASSCHELEIN, C. A., BORREMANS, E. and VAN DE WINKEL, L. (1994) *Proc. 23rd IOB Conv. (Asia Pacific Section)*, Sydney, 109.
- MATHIEU, C., VAN DEN BERGH, L. and ISERENTANT, D. (1991) *Proc. 23rd EBC Conv., Lisbon*, 273.
- MCCAIG, R. (1990) *J. Amer. Soc. Brew., Chem.*, **48**, 22.
- MCMURROUGH, I. (1995) *Proc. EBC Monograph, XXIV, Espoo*, 2.
- MEEDENER, H. (1978) *Proc. EBC Conv, Symp. Monograph V, Zouterwoude*, 110.
- MOONSAMY, N., MOCHOKA, F., O'CONNOR-COX, E. S. C. and AXCELL, B. C. (1996) *J. Inst. Brew.*, **101**, 203.
- MORRIS, G. J., COULSON, G. E. and CLARKE, K. J. (1988) *Cryobiology*, **25**, 471.
- MOZES, N., MARCHAL, F. and HERMESSE, M. P. (1987) *Biotechnol. Bioeng.*, **30**, 439.
- MUCK, E. and NARZISSL, L. (1988) *Brauwelt Internat.*, **1**, 61.
- NAUDTS, G., AERTS, G. and ISERENTANT, D. (1997) *Proc. 26th Cong. Eur. Brew. Conv, Maastricht*, 377.
- NIELSEN, H., HOYBE-HANSEN, I., IBACK, D. and KRISTENSEN, B. J. (1986) *Brygmesteren*, **2**, 7.
- NIELSEN, H., HOYBE-HANSEN, I., IBACK, D., KRISTENSEN, B. J. and SYNNESSVEDT, K. (1987) *MBAA Tech. Quart.*, **24**, 90.
- OH, K.-B. and MATSUOKA, H. (2002) *Int. J. Food. Microbiol.*, **76**, 47.
- OWADES, J. L. (1981) *MBAA Tech. Quart.*, **18**, 163.
- PAJUNEN, E. (1995) *Proc. EBC Monograph, XXIV, Espoo*, 24.
- PAJUNEN, E. and GRONQVIST, A. (1994) *Proc. 23rd IOB Conv. (Australia & New Zealand Section)*, Sydney, 101.
- PARKINEN, E., OURA, E. and SOUMALAINEN, H. (1976) *J. Inst. Brew.*, **82**, 283.
- PATINO, H., EDELSEN, C. and MILLER, J. (1993) *J. Amer. Soc. Brew. Chem.*, **51**, 128.
- PIRT, S. J. (1975) *Principles of Microbe and Cell Cultivation*, Blackwell Scientific Publications, Oxford.
- POSADA, J. (1978) *Proc. EBC Conv, Symp. Monograph V, Zouterwoude*, 207.
- POWELL, C. A., VAN ZANDYCKE, S. M., QUAIN, D. E. and SMART, K. A. (1999) *Microbiology*, **146**, 1023.
- QUAIN, D. E. (1981) *J. Inst. Brew.*, **87**, 289.
- QUAIN, D. E. (1995) *Proc. 25th Cong. EBC, Brussels*, 309.
- QUAIN, D. E. and TUBB, R. S. (1982) *MBAA Tech. Quart.*, **19**, 29.
- QUAIN, D. E., BOX, W. G. and WALTON, E. F. (1985) *Lab. Practice*, **34**, 84.
- QUAIN, D. E., POWELL, C., HAMILTON, A., RUDDLESDEN, D. and BOX, W. (2001) *Proc. 28th Cong. Eur. Brew. Conv., Budapest*, 388.
- RAYNAL, L., BARNWELL, P. and GERVAIS, P. (1994) *J. Biotechnol.*, **36**, 121.

- REISS, S. (1986) *MBAA Tech. Quart.*, **23**, 32.
- ROWE, S. M., SIMPSON, W. J. and HAMMOND, J. R. M. (1991) *Lett. Appl. Microbiol.*, **13**, 182.
- RUSSELL, I. and STEWART, G. G. (1981) *J. Amer. Soc. Brew. Chem.*, **39**, 19.
- RYDER, D. S., BOWER, P. A. and BROMBERG, S. K. (1995) *Proc. EBC Monograph, XXIV, Espoo*, 175.
- SCHMIDT, H.-J. (1995) *Brauwelt Internat.*, **13**, 130.
- SCHOFIELD, M. A., ROWE, S. M., HAMMOND, J. R. M., MOLZAHN, S. W. and QUAIN, D. E. (1995) *J. Inst. Brew.*, **101**, 75.
- SEDDON, A. W. (1975) *MBAA Tech. Quart.*, **3**, 130.
- SIDDIQUE, R. and SMART, K. (2000) 'Predicting fermentation performance using proton efflux', In, *Brewing Yeast Fermentation Performance*, K. A. Smart, ed., pp. 46–54, Blackwell Science, Oxford.
- SIGSGAARD, P. and RASMUSSEN, J. N. (1985) *J. Amer. Soc. Brew. Chem.*, **43**, 104.
- SKANDS, B. (1997) *Proc. 26th Cong. Eur. Brew. Conv., Maastricht*, 413.
- SMART, K. A. and WHISKER, S. (1996) *J. Am. Soc. Brew. Chem.*, **54**, 41.
- SMART, K. A., CHAMBERS, K. M., LAMBERT, I. and JENKINS, C. (1999) *J. Am. Soc. Brew. Chem.*, **57**, 180.
- STEWART, G. G., ZHENG, X. and RUSSELL, I. (1995) *Proc. 25th Cong. EBC, Brussels*, 403.
- STRATTON, M. K., CAMPBELL, S. J. and BANKS, D. J. (1994) *Proc. 23rd IOB Conv. (Asia Pacific Section), Sydney*, 96.
- THIBAUT, J., LEDAY, D. and COTE, F. (1987) *Biotech. Bioeng.*, **30**, 74.
- TIMMINS, E. M., QUAIN, D. E. and GOODACRE, R. (1998) *Yeast*, **14**, 885.
- TUBB, R. S. and LILJESTRÖM, P. L. (1986) *J. Inst. Brew.*, **92**, 588.
- VAN DE WINKEL, L., VAN BEVERAN, P. C. and MASSCHELEIN, C. A. (1991) *Proc. 23rd Cong. EBC, Lisbon*, 577.
- VAN VUUREN, H. J. J. and VAN DER MEER, L. (1987) *Amer. J. Enol. Viticult.*, **38**, 49.
- WALSH, R. M. and MARTIN, P. A. (1977) *J. Inst. Brew.*, **83**, 169.
- WERNER-WASHBURNE, M., BRAUN, E. I., CRAWFORD, M. E. and PECK, V. M. (1996) *Molec. Microbiol.*, 1159.
- WESTNER, H. (1999) *Brew. Dist. Internat.*, Sept. 24.
- WILLIAMS, R. P. and RAMSDEN, R. (1963) *Continuous fermentation process and apparatus for beer production*. British Patent 926847.

14

Fermentation technologies

14.1 Introduction

The object of brewery fermentation is to utilize the ability of yeast cells to convert sugar into ethanol and carbon dioxide as the major products of metabolism. The yeast also produces a series of minor metabolites such as esters, higher alcohols and acids that contribute positively to flavour. It is these myriads of minor components that characterize a beer brand and make it identifiable to a drinker. The chosen yeast must also control the elimination of undesirable flavour components arising from the raw materials or from fermentation. Much of this flavour improvement occurs in maturation (Chapter 15). Brewery fermentations are discussed in Chapter 12. In this Chapter the technology of fermentation is described with the objective of performing the process consistently to yield the highest quality beer at lowest cost. Low costs must be demonstrated as low capital cost to keep the depreciation element of brewery fixed costs as low as is achievable and as low maintenance cost. Minimum beer losses must also be achieved so that the maximum amount of beer is derived from the raw materials used. In this way brewery variable cost per unit volume of beer produced is lowered. To achieve these objectives requires careful selection of the yeast and the appropriate wort composition (Chapter 12). It also requires efficient operation of properly designed fermentation equipment. In this respect top and bottom fermenting yeasts must be considered.

The nature of fermentation was not clearly established until the latter part of the nineteenth century and so the design of vessels to effectively carry out fermentation has a history of about 150 years. This design is fundamentally influenced by the mode of separation of the yeast, i.e., top or bottom fermenting yeasts. Cool, bottom fermentation was almost entirely restricted to Bavaria until 1840 when the rest of the world was using top fermentation (Christian, 1959). Some bottom fermenting yeast was smuggled to Czechoslovakia in 1842 and so Pilsen was established as a major brewing centre. About three years later a Danish brewer, J. C. Jacobsen, took bottom fermenting yeast from Munich to Copenhagen and so the Danish city also became established as important for brewing. Of great significance at about the same time was the introduction of a bottom fermenting yeast to Pennsylvania in the USA. Its use spread rapidly through the actions of

immigrant German brewmasters such as Frederick Miller, Bernhard Stroh, Eberhard Anheuser and Adolph Coors. The use of bottom fermentation was thus spreading throughout Europe and North America at the same time as Pasteur began his microbiological research resulting in the development of a theory of fermentation, culture techniques for micro-organisms, and the principles of sterilization (Pasteur, 1860, 1876).

Progress in controlling brewery fermentation could now be made as improvements in the microbiological aspects of fermentation could facilitate engineering developments. Of critical importance in bottom fermentation was temperature control and in particular the maintenance of low temperatures (0 °C, 32 °F and less) for long periods of time. This originally required the use of large quantities of ice until the compressor refrigerator appeared in breweries from about 1873 following developments in Australia and Germany. The next 100 years saw the abandonment of top fermentation throughout the world with the exception of the UK and Ireland and rapid developments in the later years of the twentieth century to increased batch size fermentations in very large vessels (up to 6,000 hl, 3,600 imp. brl).

There has recently been renewed interest in top fermented ale beers produced in small batches in 'niche' breweries particularly in the USA. There has also been a desire to eliminate differences between top and bottom fermentation by seeking semi-continuous and continuous fermentation techniques, some of them employing immobilized yeast, when the traditional practices of top and bottom separation do not take place.

There are marked differences in the batch sizes of fermentation systems throughout the world. This reflects the market in which the particular brewer operates. International brewers producing global brands will have plants with capacities of at least 10 m. hl per annum (6m. imp. brl) and sometimes considerably greater than this in the USA and Japan. Regional brewers in many countries brew successfully in plants of annual production in the range 0.1 to 1.0 m. hl (60,000 to 600,000 imp. brl) and craft or niche brewers would operate at levels of 1,000 to 10,000 hl per annum. Fermentation processes are therefore successfully carried out in batch sizes ranging from 10 to 6,000 hl. It follows that a wide range of vessel types are used.

Techniques of fabrication are available to make fermenting vessels of all sizes. Practical sizes are limited by economic factors. It is difficult to transport by road, rail or barge, vessels much bigger than 2,000 hl capacity (1,200 imp. brl) and vessels of greater volume must be built on site at greater cost. Companies must decide on the optimum size for their own operations. Fermentation technology, therefore, embraces a study of:

- fermenters for bottom and top fermentations and consequent yeast separation
- fermenters for continuous and semi-continuous operation requiring no yeast separation
- fermentation control systems.

Some basic principles first need outlining so that vessel design and operation is set in the context of the biochemical requirements of successful brewery fermentation (see also Chapters 12, 13).

14.2 Basic principles of fermentation technology

14.2.1 Fermentability of wort

The main objective is to ferment wort to the desired gravity; this is often called the required degree of attenuation. The proportion of the wort dissolved solids (extract) which can be fermented is called the percentage fermentability of the wort:

$$\text{Fermentability}(\%) = \frac{\text{Original gravity} - \text{Final gravity}}{\text{Original gravity}} \times 100$$

The original gravity can be expressed in °P (Plato), which measures the concentration in weight/weight terms as grammes of solids per 100 grammes of wort, or in °Sacch, which relates the specific gravity of the wort to that of water taken as 1,000. Final gravity means the gravity of the wort when it is fully fermented such that adding more yeast or leaving it longer will lead to no further fall in gravity. This lowest gravity is often called the attenuation limit gravity and when it is reached the beer is said to be fully attenuated. Therefore if wort of original gravity 48 °Sacch (12 °P) is fermented to a gravity of 12 °Sacch (3 °P) the percentage fermentability is:

$$[48 - 12/48] \times 100 = 75\% \text{ or } [12 - 3/12] \times 100 = 75\%$$

The alcohol formed in the fermentation has a lower density than water and so it decreases the final gravity. The final gravity, therefore, does not show the amount of extract left in the fermented wort. The attenuation limit gravity referred to above is therefore called the apparent attenuation limit and what is calculated by the equation is the apparent attenuation of the wort. To measure the real attenuation the alcohol must be removed, e.g., by distillation before determining the gravity. The real attenuation is approximately 80% of the apparent attenuation. The true factor published by Balling in 1880 was 0.81, in modern practice the real attenuation can be obtained from the apparent attenuation by the use of tables.

To determine the degree of attenuation achievable from a given wort the attenuation limit is usually measured in the laboratory. Yeast, pre-washed with wort, is mixed with filtered wort, which is fermented at 25 °C. A specific gravity reading is taken after two days and then repeated twice a day until the gravity does not change. This gravity is the apparent attenuation limit. It is the highest apparent degree of attenuation that can be achieved by fermentation of all fermentable material in the extract of the wort. It is, of course, governed by the raw materials chosen to make the wort and the extent of enzyme activity in the brewhouse.

In the brewery fermentation the apparent attenuation limit is not usually reached. Some brewers set a specific attenuation limit for a particular beer and attempt to reach this value in a preset time against a preset fermentation temperature regime. If there is a large difference between the final attenuation achieved and the apparent attenuation limit as determined in the laboratory then there is fermentable extract present in the beer and this represents a risk of supporting infection by yeasts and bacteria. This would subsequently cause the beer to go hazy and would create off-flavours. Generally, in modern large batch lager fermentations, the objective is to try to ferment the beer to the limit. This is not the object in the production of cask ale in the UK when residual carbohydrate is required in the beer to allow secondary fermentation and cask conditioning to take place (Chapter 21).

14.2.2 Time course of fermentation

By determining the specific gravity of the wort at time intervals one can follow the course of fermentation. Typical fermentation profiles for ale and lager fermentations are shown in Fig. 14.1, which also includes typical temperature regimes although these vary between breweries. The decline in the specific gravity is matched by the growth of the yeast as sugars are metabolized and ethanol produced. The pH value of the wort falls as

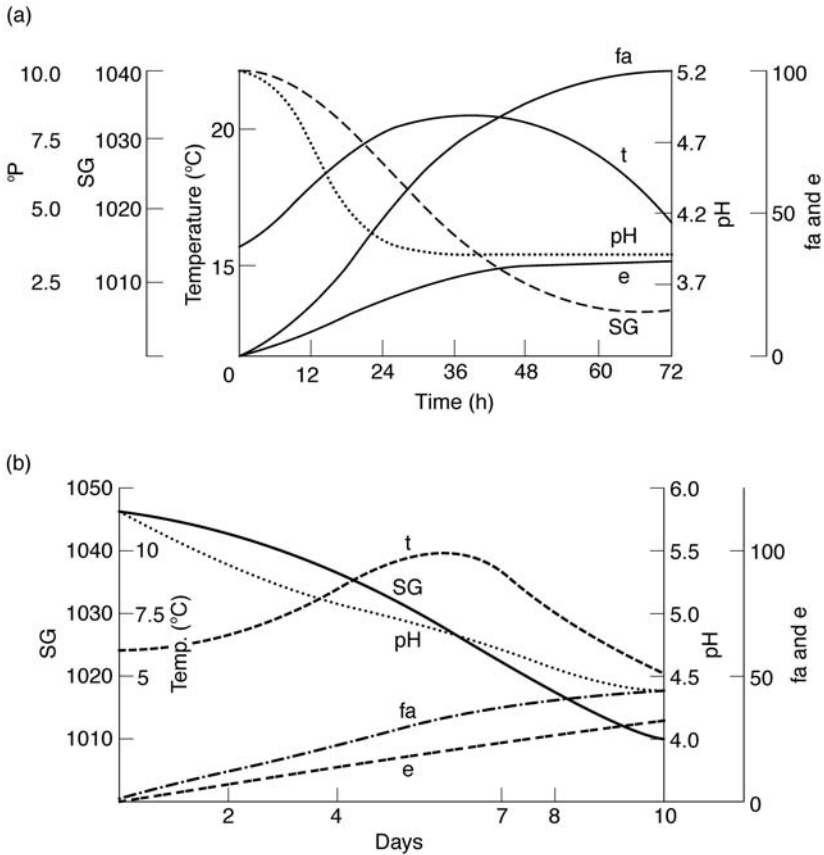

Fig. 14.1 Time course of fermentation for ale (a) and lager (b) beers. fa, level of fusel alcohols ($\mu\text{g/l}$); e, level of esters ($\mu\text{g/l}$); t, temperature $^{\circ}\text{C}$. (Hough *et al.*, 1982).

ammonium ions and amino acids are taken from the wort by the yeast and organic acids are secreted (Chapter 12). Major flavour compounds, the esters and higher alcohols are released into the wort as the yeast grows and so increase in concentration as fermentation proceeds.

The concentration of these flavour compounds is critical for the consistency of the beer brand and the flavour profile of the beer (Chapter 20). Brewers need to be aware of the decline in concentration of flavour compounds, which can occur towards the end of fermentation, and in maturation (Chapter 15). This can occur as volatiles are carried out with evolving carbon dioxide ('gas purging') or are re-absorbed by the yeast. Marked differences can be seen in the time course profiles of ale and lager fermentations and these differences are reflected in the flavour profiles of the resulting beers. It follows that the vessels for fermentation must be equipped to regulate these differences consistently so that consistent products can be brewed.

14.2.3 Heat output in fermentation

Fermentation is an exothermic process. The metabolism of wort sugars in brewery fermentation can be represented in general by the summation of the biochemical pathway discussed in Chapter 12:

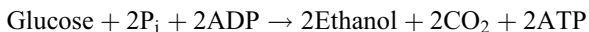

In this version of the equation energy is fixed and stored by the yeast cell as ATP. The free energy of reaction (ΔG) can be calculated for each stage of the process (Mahler and Cordes, 1969) and a net figure of 157 kJ/mole can be derived. However, the ATP generated is used in further reactions in the cell:



Therefore the overall heat of production can be assessed as $157 + 62 = 219\text{kJ/mole}$ of glucose fermented. If temperature is to be controlled during fermentation to ensure a consistent performance then this heat must be removed. The heat produced during a typical fermentation can thus be assessed from this figure (Anderson *et al.*, 2000).

Consider a 12°P wort; this will contain 12.6 kg of extract/hl of wort of which, say, 75% will be fermentable. The molecular weight of glucose is 180 and so 219 kJ/mole of glucose is equivalent to $(219/180) \times 1000\text{ kJ/kg}$ of glucose, i.e., 1217 kJ. Therefore fermentation of 1000 hl of wort would yield in total:

$$1000 \times (12.6 \times 75/100) \times 1217 = 11.5\text{GJ}$$

The heat is not uniformly given out but will reach a peak at maximum fermentation rate. This peak has been variously estimated but a value with practical worth, is 0.22 kg extract/hl/h (Fricker, 1978). The maximum cooling load for a 1000 hl fermenter would therefore be:

$$1000 \times 0.22 \times 1217 = 0.26\text{ GJ/h}$$

This heat must be removed from the fermenter if the temperature of fermentation is to be controlled. The amount of cooling required depends on the temperature range to be maintained. Frequently in the production of ales with rapid top fermentation the temperature is allowed to rise unrestricted over the first 48 to 60 hours of fermentation. Temperatures of over 22°C (72°F) can be reached. Cooling is usually then applied to lower the temperature to around 15°C (59°F) for a brief maturation (Chapter 15) before proceeding to conditioning or to cask racking. In a lager fermentation temperature of the fermenting beer is usually controlled so that it rises to no more than 13°C (55°F) after pitching at around 8°C (46°F) and is then lowered by progressive cooling to about 5°C (41°F). The beer will then proceed to the maturation and conditioning stage. An equation has been derived to calculate the amount of cooling required which can be applied to any fermentation situation (Anderson, *et al.*, 2000):

$$Q = M \times C_p \times \Delta t$$

where Q is the heat in kJ, M is the mass of the beer in kg, C_p is the specific heat in kJ/kg/°C, and Δt is the required temperature change of the beer. Therefore if a fermenter contains 1000 hl of beer with a specific heat of 4.05 and it is required to lower temperature from 13°C to 5°C, the heat removed will approximately be (assuming gravity to be 1.00):

$$1000 \times 100 \times (13 - 5) \times 4.05 = 3.24\text{ GJ}$$

There is frequently debate between brewers and equipment suppliers about the rate of cooling required to remove this quantity of heat. To control temperature during fermentation a rate of temperature reduction of 1°C/hour is often used. In the above example this would equate to:

$$1000 \times 100 \times 3.24 = 324 \text{ MJ/h}$$

Some brewers require a rate greater than this to ‘crash cool’ a fermenter to precipitate yeast and achieve a conditioning temperature of $< 0^\circ\text{C}$. This requires more cooling equipment with a consequent increase in revenue and capital cost. However many vessels in use throughout the world are incapable of cooling at even half of this rate. This will be discussed later.

14.3 Bottom fermentation systems

Most beer in the world is brewed with strains of the lager yeast *Saccharomyces carlsbergensis* (see Chapter 11 for discussion on classification), which tends to separate to the bottom of a fermenting vessel after fermentation. Fermenters for lager fermentation are thus the most common and important in brewing and must allow for this property of the yeast.

14.3.1 Choice, size and shape of vessels

One of the most significant advances in fermenter design was the move to closed fermenters following the work of Leopold Nathan who in 1908 and in 1927 patented designs of enclosed vertical cylindrical vessels with conical bases. Nathan claimed faster fermentation rates and the collection of carbon dioxide as well as fermentation control by temperature and the use of the vessels for fermentation and maturation (Nathan, 1930). Nathan’s ideas took some time to be accepted but the cylindroconical vessel was in wide use by the 1960s.

Before Nathan vessels were fully accepted some cylindrical tanks were built with gently sloping bases but these tanks were seldom fully successful for yeast removal. A further development in the USA in 1968 was the Rainier Unitank (Knudsen and Vacano, 1972), which had a conical base with a slope of 25° from the horizontal. This vessel was used for fermentation and maturation. These tanks were equipped for cooling at the maximum output of fermentation and for cooling to maturation temperatures of 0°C .

Modern forms of the Nathan vessel are now the most widely used fermenters. These vessels (Fig. 14.2) can range in size from 100 to 6,000 hl (60 to 3,600 imp. brl). An important characteristic of these vessels is the steep angled cone at the base. An angle of 70° is required to allow the yeast to settle into the base of the vessel at the completion of primary fermentation. This allows most of the yeast to be separated, leaving the beer comparatively free of yeast. This has allowed, in some systems, maturation and conditioning to take place in the same vessel as fermentation without the need to centrifuge the beer during transfer to a second vessel for maturation (Chapter 15).

A number of advantages have been claimed for cylindroconical vessels compared to open square or round fermenters (Hoggan, 1977):

- lower capital costs of 25–35%
- lower operating costs of 50–65%
- decreased beer losses
- increased vessel utilization
- reduced losses of bitter substances
- lower space requirement
- potential for the collection of carbon dioxide.

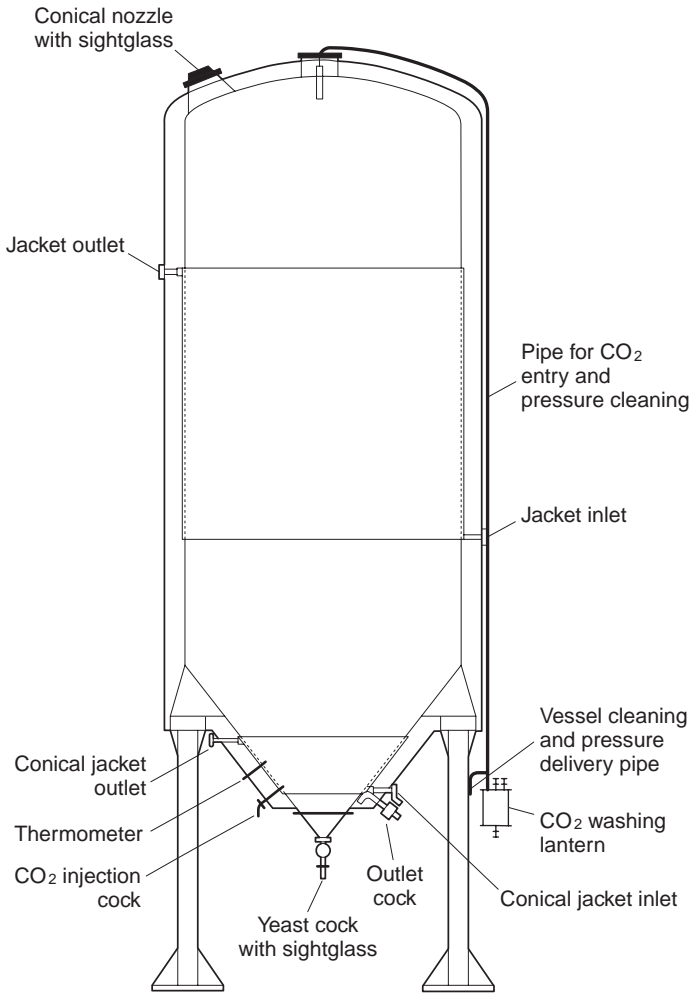

Fig. 14.2 Cylindroconical fermentation vessel, (Hough *et al.*, 1982).

These vessels are usually 3–4 times taller than their diameter and work at pressures of 1–1.5 bar above atmospheric. Tank diameters in the UK are usually 3.5 to 4.5 m (11.5 to 15 ft.). Heterogeneous fermentations have been observed in tanks much greater than 20 m (66 ft.) high and for this reason in recent developments the height of vessels has been kept to less than 15 m (49 ft.). This phenomenon has not been fully explained but special circumstances do apply to very large vessels (>2,500 hl 1,500 imp. brl) in relation to temperature gradients and cooling (Section 14.3.3). In classic European lager production more squat vessels are used where the ratio of diameter to height is <2:1. This gives a fermentation profile that equates more completely to that achieved in horizontal tanks. In tall vessels when the ratio is >3:1, there is a tendency for increased production of higher alcohols at the expense of esters. This may be caused by increased amino acid utilization caused by the increased beer circulation generated by rapid carbon dioxide production. Increasing the size of the vessel can lower cost per unit volume. Doubling the size of the vessel leads to a cost increase of about 35% (Maule, 1977). In general the greater the volume to surface area ratio the lower the unit

volume cost will be. Large vessels are sited in the open. These are subject to planning regulations in some countries.

Cylindroconical vessels cannot be completely filled for primary fermentation. A large volume of foam is formed by the evolution of carbon dioxide and this could cause pressure release valves to block. The headspace volume of the tank should therefore be at least 25% of the pitched wort volume. From this discussion it is difficult to generalize about the optimum size and aspect ratio of fermenters. As a general rule filling the vessel should not take longer than 12 hours, irrespective of the number of brews being run to the vessel for fermentation. Continuous filling with fresh wort will lead to increased production of α -acetolactate and result in enhanced maturation time for diacetyl removal (Chapter 15). It is useful in a brewery to have a range of sizes of vessels. If the brew length is 1000 hl (600 imp. brl) then vessels of 4,000–5,000 hl (2,400–3,000 imp. brl) capacity will be suitable but it will be advantageous to have vessels of 250 hl (150 imp. brl) size for propagation and some 500–1,000 hl (300–600 imp. brl) vessels for new product development and trial work.

14.3.2 Construction of cylindroconical vessels

Originally fermenting vessels for bottom fermentation were constructed of mild steel with a glass or epoxy resin lining. This lining had to be frequently inspected to ensure its integrity. Mild steel was also prone to rusting and modern vessels are almost always constructed of chrome-nickel stainless steels.

Metals and design

Generally the steels used are stainless and austenitic, i.e., containing carbon, which forms a carbide with the gamma form of iron, which is normally only stable at high temperatures but can be stabilized at normal temperatures by the inclusion of elements such as chromium, nickel, and molybdenum. These steels are often referred to in brewing by the general classification V2A and V4A, but these categories cover a series of different alloys. The class can be subdivided into AISI 304 (V2A group) and AISI 316 (V4A group), which are the steels in most common use. Resistant properties of 316 steels are enhanced by the inclusion of molybdenum (Table 14.1). A further category of steels, designated 321 contain titanium. Normally 304 stainless is used. However V2A steels are not fully resistant to chloride ions or to pH values < 4.5. This is not usually a problem for fermenters but with liquors having high chloride contents 316 can be specified, but it is much more expensive than 304 steel.

A very important factor is the surface smoothness of the steel that can be achieved in manufacture. It should be as smooth as is possible so that indentations cannot provide areas for potential microbial contamination. Cold rolling of stainless plate will yield a surface with a 'roughness' (Ra) of 0.6 to 0.8 μm . In some systems of work this type of finish is designated '2b'. Electro-polishing can lower Ra to 0.3 to 0.4 μm but this will be at greater cost and is not always specified by brewers. Vessels are now almost always produced to

Table 14.1 Composition of austenitic stainless steels (Barnes, 2001)

Type	Carbon (%)	Chromium (%)	Nickel (%)	Molybdenum (%)
304	0.03–0.06	17.5–19.0	8.0–12.0	–
316	0.03–0.07	16.5–18.5	10.0–14.0	2.25–3.0

standards of design that can be specified by the brewer at the time of making an enquiry to purchase. Choice is thus facilitated which can concentrate on price aspects. Generally three design standards are recognized in Europe and North America: AD Merkblätter (Germany), ASME (American Society of Mechanical Engineers) VII div 1 (USA), and BS 5500 (UK). Vessels operating at pressures > 0.5 bar will normally be subject to national regulations relating to pressure vessels and will require inspections for insurance purposes.

Cooling jackets

The fermenter must be equipped with a cooling system to remove heat generated during fermentation and to allow the control of temperature to the required profile. If the vessel is to be used for maturation as well (Section 15.2.5) then there is the requirement to cool to less than 0°C (32°F) and to hold this temperature for several days. Systems of direct and indirect cooling can be used. In direct cooling ammonia gas is used as the refrigerant and cooling is achieved by expansion and evaporation of the liquefied gas. In indirect cooling a secondary coolant (such as IMS, industrial methylated spirit), generated from a refrigeration plant is used. This coolant is circulated through the fermenting vessels and thence returned to the plant. Cooling jackets are constructed so that good heat exchange is possible and several designs are available (Fig. 15.2). The choice often depends on the expertise of the proposed manufacturer. Limpet coils are wound onto the vessel surface and seam welded, they have a relatively heavy construction. An alternative is the pressed corrugated 'profile' plate (Barnes, 2001), which can be pre-formed and spot welded to the vessel shell. In some versions this is called a 'dimple' jacket. There is the further alternative of a 'quilted' panel, which is hydraulically inflated after spot welding to the vessel surface. This system has a low volume and is favoured with direct expansion cooling using ammonia. If properly specified and manufactured the design of the cooling jacket has little impact on fermentation performance. A fully equipped fermenter will probably have two cooling sections on the cylinder of the tank and a further section on the cone.

Vessel fittings

Vessels are filled and emptied from below, reducing oxygen ingress. Vessels are fitted with pipes for the addition of wort, the removal of yeast, and the removal of beer. There are also pressure relief and vacuum relief systems, which are fitted into a top-plate assembly. Cleaning-in-place (CIP) fluids must also be introduced and this is usually through the top plate although, for ease of access, the valve may be situated at the bottom of the tank.

One of the main factors in the operation of these vessels is ensuring the integrity of the pipe-work systems so that yeast, wort, beer and cleaning fluids are, when required, handled separately and not allowed to mix. This is frequently achieved by using a 'dial-a-pipe' system where connections are made manually. The different lengths of the U-shaped connection pipes make wrong connections impossible. The pathways so made are opened and closed by manual or remotely operated butterfly valves.

In large modern fermenting 'tank farms' the vessels are often permanently connected by the pipe-work system. Valves are then either connected to every tank or collected into a 'valve routing block' to which every tank is connected and which is automatically and remotely controlled. The problem in this system is valve leakage which can cause severe damage if, say, cleaning fluid leaks into the beer. The risk is reduced by the use of 'double seat' valves that provide leakage indication. This assembly contains an upper and lower valve controlled by springs and separated by a small space. Opening the valve is

achieved by compressed air, which overcomes the pressure of the springs. On release the compressed air escapes and the pressure of the springs takes over, this forces first the upper and then the lower valve to close. The small space between the valves still exists and if a valve is not properly sealed liquid will flow through the space and out of the assembly through a pipe. Leaking is thus detected. These systems are now favoured with the desire to lower manpower costs in breweries, but are only of use if closely examined frequently!

Carbon dioxide produced during fermentation must be removed from the vessel irrespective of whether this gas is collected for further use (Section 15.4.3). This gas pressure must, therefore, be released and the vessel must also be protected against the development of a vacuum. CIP fluids must be safely and effectively introduced into the tank. For ease of manufacture and ease of operation it is now common practice to incorporate these fittings into a top plate of about 1 m (3 ft.) diameter. If the vessels are standing in the open air this top plate must be protected against the weather.

Pressure relief is usually by a simple weight-operated valve (Fig. 14.3), although spring controlled systems are sometimes used. Excess pressure can develop from vessel filling, and expansion of fermentation gases when hot CIP is used. A reduction in pressure can occur on emptying the vessel, from the reaction of carbon dioxide with caustic detergents and when cold liquid enters the tank after hot cleaning. Hot cleaning of fermenting vessels is always dangerous to the integrity of the tank and, if possible, it is recommended that fermenters are cleaned at temperatures of $< 30^{\circ}\text{C}$ (86°F). Vacuum relief valves incorporated into the top plate are often weight operated, working in the reverse mode to the pressure relief valve (Fig. 14.3).

The CIP spray head will also be connected into the top-plate assembly. Vessels will have a high organic soil level and will be best cleaned by a combination of liquid impact and detergent action. Many types of spray head are available but the most effective utilize

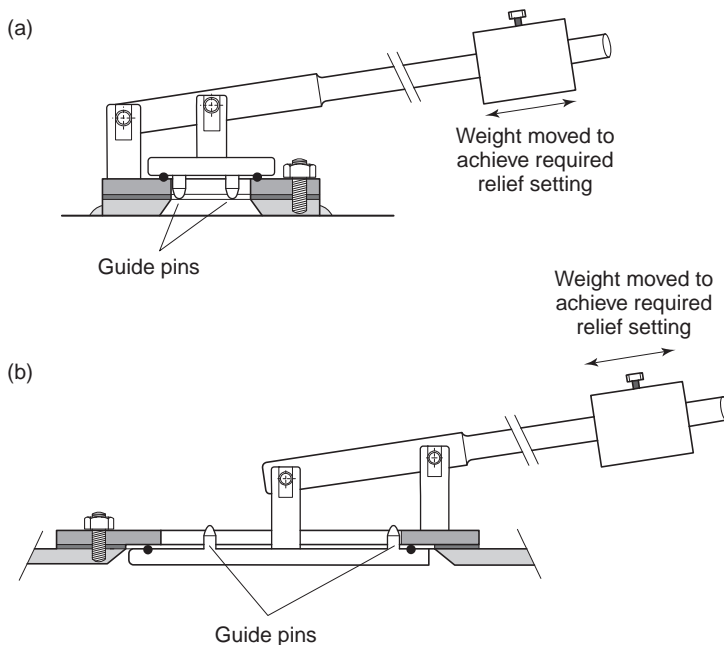

Fig. 14.3 Weight operated pressure (a), and vacuum (b), relief valves (Anderson *et al.*, 2000).

a dual planar system where the nozzles rotate on the head whilst the whole head rotates on the supply pipe (see Fig. 14.6 on page 525).

Insulation

Fermenters require insulation. Outside tanks are insulated against ambient conditions, which obviously vary considerably throughout the world. Indoor tanks will also require some insulation to lessen the demands on the temperature control system. Insulation is best added to the tank during manufacture for vessels up to a size of around 2000 hl (1200 imp. brl).

Insulation materials usually contain chloride ions and so a chloride inhibiting layer must be applied to the tank to protect the stainless steel prior to the application of the insulation. There is a wide range of insulation materials available and individual companies often have very distinct preferences. The basic choice is between polyurethane foam and phenolic foam. Phenolic foam is less flammable although polyurethane can incorporate fire retardants, but these contain chloride. Inorganic materials such as glass fibre or mineral wool are completely non-flammable but are less good insulators. The thickness of the insulation used also varies widely. The capital cost of additional insulation is small in relation to the total cost of the vessel and so it is foolish to compromise here. Polyurethane foams are often applied in thicknesses of 100 to 150 mm (4 to 6 in.), whereas phenolic foams have been claimed to be effective at 75 mm (3 in.) (Anderson, *et al.*, 2000). Some brewers will specify a maximum permitted temperature rise in, say, summer conditions of $< 1^{\circ}\text{C}$ (1.8°F) per day.

The insulation must be sealed against water ingress. This can be achieved with an aluminium foil applied over the insulation, which must be applied with care to avoid any points of potential water entry. Finally, the outdoor vessels must be externally clad to protect the insulation from weather and mechanical attrition. Plastic coated mild steel profile sheets are normally used. Jointing these sheets is critical so that water runs off the cladding and does not collect on the joint and hence gain access to the insulation. In hot countries, with high solar radiation and reflection light colours are best.

14.3.3 Operation of cylindroconical vessels

From a technological standpoint the operation of cylindroconical fermenters requires a consideration of adding yeast to the wort and filling the vessel (pitching), temperature control, and vessel cleaning. The removal of yeast will be discussed in Chapter 15.

Addition of yeast (pitching)

The metabolism of wort by yeast is discussed in Chapter 12. Here we are concerned with the technical requirements for consistent fermentations. Only if the fermentation of wort can be performed reproducibly can the integrity of the beer brand be maintained. A vital factor in consistency is the method of addition of yeast to wort. At the start of fermentation rapid yeast growth must be encouraged and this requires both the introduction of oxygen to the wort and very efficient mixing of the yeast with the wort. Clumping of yeast must be avoided so that the yeast cells can gain speedy access to the wort nutrients. In modern plant this intimate mixing is achieved by dosing yeast into a flowing stream of wort. This is essential for closed fermenters as it is impossible to pour yeast into the wort, as is the practice in some systems of open fermentation (Section 14.4).

Oxygenation of wort can be achieved by the use of sterile air or oxygen. Using air a wort oxygen level of 8 to 9 mg/l is achievable and this is adequate for many

fermentations. For higher-gravity fermentations (say $> 12^{\circ}\text{P}$, 1048°Sacch) it is now common to use oxygen instead of air. Concentrations of up to 30 mg/l are possible but 12 to 20 mg/l are normal. Over oxygenation is sometimes thought to be impossible because oxygen is so rapidly utilized by the yeast. However, with some strains of yeast excess oxygen in the wort can lead to overgrowth and lower ethanol yields. It is therefore good practice to match the oxygen requirement of each particular yeast strain (Chapter 13).

Oxygen is normally added after wort cooling but before the yeast. A number of types of injection system are in use. Sintered ceramic candles can cause the injection of a very fine stream of bubbles to achieve intimate mixing but these systems are difficult to clean. A venturi pipe is very effective. Air or oxygen is introduced just before the constriction in the pipe and then mixes thoroughly with the wort in the turbulent flow resulting from the subsequent increase in diameter of the pipe (see also Chapter 10).

Yeast for pitching has normally been derived from previous fermentations and maintained in yeast storage vessels as a slurry at $< 5^{\circ}\text{C}$ (41°F). The essence of successful pitching is the measurement of the quantity of the yeast to be pitched into the wort (Chapter 13). This can be achieved by volume, mass, or weight but these methods rely on the slurry being of constant composition and do not compensate for yeast viability. Methods are now available for making these compensations.

- Volumetric methods. These methods are simple, cheap and can be successfully carried out by relatively unskilled personnel. A calibrated vessel can be used to measure the volume or more effectively a volumetric flow meter such as a magnetic flow meter. Peristaltic pumps have also been used. Account must be taken of the viability and concentration of the yeast to achieve good results. The method is affected by carbon dioxide gas trapped in the yeast slurry. This cannot be assessed and hence markedly different carbon dioxide concentrations in different slurries will affect the amount of yeast pitched into the wort.
- Mass methods. The problem of trapped carbon dioxide can be avoided by the use of a mass meter, e.g., of the Coriolis type. Again account must be taken of the viability and concentration of yeast in the slurry. Methods of this type are gaining use in breweries often in conjunction with instrumental systems to measure yeast concentration.
- Weight methods. This is a common and effective system. If used with yeast slurries the weight method requires the yeast storage vessels to be installed on load cells so the vessel contents can be weighed. The method is also commonly used with pressed yeast cake, which is subsequently slurried in chilled water prior to addition. The main problem with these methods is the reliability of the load cells that do not work well in the conditions of the yeast storage area (wet and cold!). As with other methods account must be taken of viability and concentration of the yeast.

As simply applied these methods suffer from the inherent variability of yeast slurries in terms of viability and concentration. The number of cells in a yeast slurry can be estimated in a laboratory using a Coulter counter. This figure can then be used to estimate the volume of slurry needed to give a particular yeast count in the wort. The Coulter counter will not distinguish between live and dead cells. To do this many brewers will apply a compensation factor to the amount of slurry to be pitched. Viability will be assessed by the methylene blue staining method. In this method dead cells stain blue and viable cells remain colourless (Chapter 13). The method has, however, been considered unreliable for viabilities of $< 85\%$ (Institute of Brewing, Analysis Committee, 1971).

There have been recent attempts to improve methods of determining concentration and viability of slurries by using new technologies. There has also been the attempt to link

these methods into automatic systems of yeast pitching in breweries to avoid laboratory involvement and devolve the control of the process to brewery personnel. The objective here has been to improve the consistency of brewery fermentations and achieve more predictable attenuation and flavour volatile production. A skid-mounted instrument has been described (Teass, 2000) that will provide instantaneous cell counts in the 0 to 2 billion cells/ml range. Results obtained with the instrument correlated well with laboratory measurements. The volume to be pitched is controlled by a flow meter but corrections for viability still have to be made. Other instruments purport to measure viable cell concentration. A biomass sensor measures the dielectrical permittivity of yeast cell suspensions. This system utilizes a radio-frequency signal to create an electrical field through which the yeast cell suspension can flow. The yeast slurry acts as a dielectric in that the electric field gives rise to no net flow of electric charge but only to a displacement of that charge. A reading of the displacement angle can be correlated with the concentration of intact cells. The assumption is made that intact cells are viable cells. On-line and off-line instruments have been developed using this principle (Carvell *et al.*, 1998). The sensor can be calibrated to different yeast strains used for different brewery fermentations.

The actual pitching rate used varies considerably between breweries and rates of 5 to 20 million cells/ml of wort are common depending on the specific gravity of the wort. An optimum level is considered to be 10 to 12 million cells/ml and this should result in a reproduction rate for lager yeast of 3 to 5 times (Stewart and Russell, 1998).

Temperature control

The heat output during fermentation has been discussed (Section 14.2.3). It follows that for reproducible lager fermentation in a brewery this excess heat must be removed by the cooling system so that the temperature of the fermenting wort can be controlled to a chosen profile. The beer must also be cooled at the end of fermentation to achieve the maturation temperature (Chapter 15) and to help the sedimentation of the yeast.

All three methods of known heat transfer can affect brewery fermentations. Conduction occurs when heat is transferred through the vessel wall, e.g., from the insulation. Radiation can occur from, say, direct sunlight on the vessel surface. But the most important factor to deal with is convection arising from movements within the fermenting liquid itself. Convection can be caused by density gradients arising from unequal temperature distribution in the vessel. These convection currents are enhanced by the movement of the liquid caused by the natural evolution of carbon dioxide bubbles during the fermentation of the wort sugars. A complex system thus operates in the fermenter which can, however, be subjected to basic physical analysis. The rate of heat transfer can be expressed in an equation derived from Fourier's Law:

$$Q = U.A.\Delta t$$

Where Q is the rate of heat flow or conductivity, W, measured in calories/second, A is the area of heat transfer in m², U is the heat transfer coefficient in W/m²/°C and Δt is the temperature difference in °C.

For a fermenting vessel the term A is the area of the wall of the vessel subject to the temperature difference (Andrews, 1997). This could be the whole of the vessel area if the effects of insulation are being considered or the area exposed to the cooling jackets if considering the effect of coolant. U is difficult to calculate and is dependent on a combination of factors relating to fluid viscosity and density and conductivity and fluid

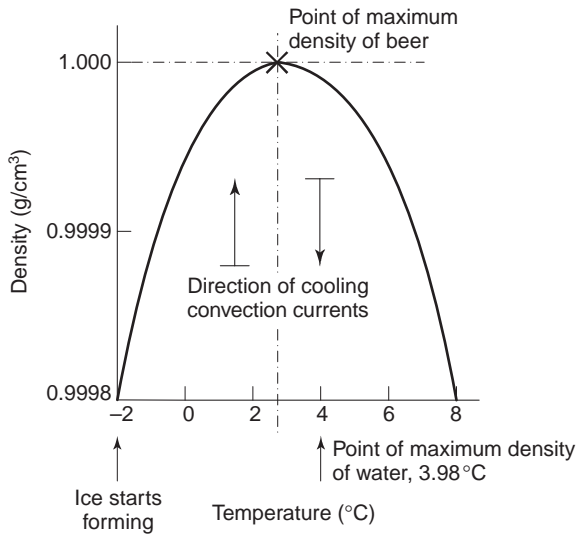

Fig. 14.4 Change in density of fermenting beer with change in temperature (Barnes, 2001).

velocity at the vessel wall. Extraneous materials on the vessel wall, e.g., fouling by yeast deposits will also affect this fluid velocity and conductivity.

If a temperature difference is now established between the fermenting beer and the vessel wall by means of a coolant, the beer adjacent to the vessel wall (sometimes called a beer film) will move downwards as the wall temperature will be lower than the beer temperature. A temperature profile will thus be set up between layers in the beer and the coolant. This will result in the establishment of density gradients further causing convection currents.

An added factor to be considered in the temperature distribution in fermenters is the inversion temperature (Fig. 14.4). Water is most dense at 4 °C (39.2 °F). Water warmer than 4 °C will rise and so on cooling a large tank, cold water (or fermenting beer) will initially flow down the tank wall until it reaches 4 °C (the inversion temperature) when the flow pattern will reverse and the fluid will rise. The temperature of maximum density of beer is affected by alcohol content and extract. The temperature of maximum density of a 12 °P (1048) beer is about 2.5 °C (36.5 °F) whereas a 16 °P (1064) beer would have a maximum density at 1 °C (33.8 °F); lower gravity beers will obviously be closer to 4 °C at maximum density.

It is a real practical challenge to achieve a uniform temperature distribution in a cylindroconical fermenting vessel by using cooling jackets on the vessel and cone walls. We are dealing with the efficiencies of heat transfer from the beer film adjacent to the vessel wall into the bulk of the beer and heat transfer to the coolant from the beer film. There will also be the effect of the thickness of the vessel wall itself although as this is usually about 5 mm (approx 0.2 in.) the thermal conductivity is very high (4,000 W/m²/°C). The driving force in temperature distribution is the convection currents. Having a large temperature difference between the coolant and the vessel wall will increase the rate of heat transfer and potentially improve temperature uniformity in the vessel. However, this is limited as freezing of the beer on the vessel wall must be avoided. Sophisticated systems have employed variable temperature of coolant using a lower temperature during fermentation than at the end and so avoiding freezing, however, these systems are too

complex to operate in most breweries and the temperature of coolant chosen is usually a compromise choice at about -5°C (23°F) to provide optimum cooling without freezing.

Good thermal conductivity in the beer film adjacent to the vessel wall is to be encouraged. The strength of convection currents will theoretically be increased by a large temperature difference between the bulk of the beer and the film and the release of carbon dioxide creating turbulence at the peak of fermentation. But at the end of fermentation, movement in the vessel is again solely as a result of density differences which, at the temperature of maximum density will be at a minimum. A typical U value during fermentation for the beer side film transfer to the beer bulk would be $400\text{ W/m}^2/^{\circ}\text{C}$ but this will be less when carbon dioxide production declines.

Heat transfer to the coolant is easier to assess than heat transfer from the beer film to the bulk of the beer. A high velocity of coolant (1 m/s) to create turbulence is the most important factor in efficient heat transfer. A low viscosity is also favourable which is often the reason to prefer ethanol in the form of industrial methylated spirit (IMS) to propylene glycol:

Viscosity of IMS, 7.5 cP at -3 to -5°C (27 to 23°F)

Viscosity of propylene glycol, 18 cP at -3 to -5°C (27 to 23°F)

A heat transfer coefficient of $2340\text{ W/m}^2/^{\circ}\text{C}$ is achievable with IMS and about 1900 with propylene glycol. Ammonia is very effective as a primary refrigerant used as a compressed gas and of course has zero viscosity as far as these comparisons are concerned and can create high turbulence during evaporation resulting in a heat transfer coefficient of $4,000$. The overall heat transfer coefficient therefore must be calculated from the sum of the individual coefficients:

$$1/U = 1/U_{\text{beer side}} + 1/U_{\text{coolant side}} + 1/U_{\text{wall resistance}} + 1/U_{\text{fouling}}$$

This equation includes a contribution of the effect of fouling on heat transfer on both the beer side and coolant side of the system. In practice, with secondary refrigerants such as IMS there is very little fouling on the coolant side. This is more of a factor in direct expansion systems with a gas like ammonia, which needs a lubricating oil on internal surfaces of the cooling jackets.

There have been few reports on investigations of temperature distribution in large tanks in the last 25 years (Andrews, 1997) and many of the design proposals of brewery engineers relate to the theory discussed above and experimental investigations of the 1970s (Maule, 1976, 1986). From these investigations and unpublished results (Barnes, 2001) it is clear that the natural convection currents are inadequate to provide totally uniform cooling irrespective of the position of the cooling jackets on the vessel or the nature of the coolant used. Beer in the upper volume of a tank may hardly change its temperature throughout a cooling regime. Temperature probes in the lower zones of the tank may indicate that temperature control is being achieved but this is often not the case for all the beer in the tank. This is clearly unsatisfactory and can lead to inconsistencies in flavour volatile production and attenuation.

This has prompted experiments in agitation of the contents of the vessel. Small amounts of a gas such as air or carbon dioxide can be introduced to the base of the vessel for this purpose. When carbon dioxide was injected through a sintered stainless steel candle at 100 g/min . for four minutes (Lemer *et al.*, 1991) improvements in the uniformity of temperature and subsequent cooling were achieved. Mechanical rousers are in use in several breweries but they are difficult to maintain and present a potential source of microbial infection. A

novel proposal (Andrews, 1997) is to construct split cooling jackets so that only half of the circumference is providing cooling as the temperature is approaching that of maximum density, i.e., that at which flow inversion occurs. This will cause an increase in heat transfer coefficient, as fluid movement would be maintained. Temperature gradients would then be generated horizontally and not vertically thus avoiding layering in the tank. Agitation during primary fermentation is disliked by some brewers because of the consequent increase in fermentation rate and increased organic acid production and lower beer pH value. It is, however, important to pay attention to the uniformity of temperature distribution in large cylindroconical vessels for regularity of beer flavour development.

In a secondary coolant system the coolant is circulated by pumps through the cooling jackets on the vessels. The coolant itself is warmed and is returned to a refrigeration plant for further cooling. This system is thus 'indirect'. In the refrigeration plant the secondary coolant is cooled by a primary coolant, which evaporates and so takes heat from its environment. Chlorofluorocarbons (CFCs) have frequently been used for this purpose in breweries. The compounds are given an 'R' number, e.g., R22, where the number relates to the number of carbon, hydrogen and chlorine atoms, but these systems of nomenclature are sometimes confused. These compounds have ozone-depleting effects and are gradually being replaced by ammonia according to internationally agreed protocols. However, ammonia is a very corrosive and toxic gas causing acute irritation of the respiratory pathway. It is also explosive when mixed with air at high temperatures. It follows that rigorous safety procedures must be in place in breweries where this gas is used in the refrigeration system.

Ammonia gas can be used directly as the primary refrigerant in a direct expansion cooling system (Fig. 14.5). Liquid ammonia is pumped through the cooling jackets at a defined pressure and about 10% of the mass evaporates causing cooling. The mixture of gas and liquid is returned to a receiver. The gas is then re-compressed and condensed to a liquid and can be returned through the cooling jackets. Direct expansion systems consume between 35 and 45% less energy than indirect systems but the dangers of using ammonia remain and in many breweries indirect systems are in use with the trend to replace the primary refrigerant CFCs in these systems with ammonia.

It is evident that control of temperature in the whole of a cylindroconical vessel is difficult. The position of the temperature probes is critical so that correct control of

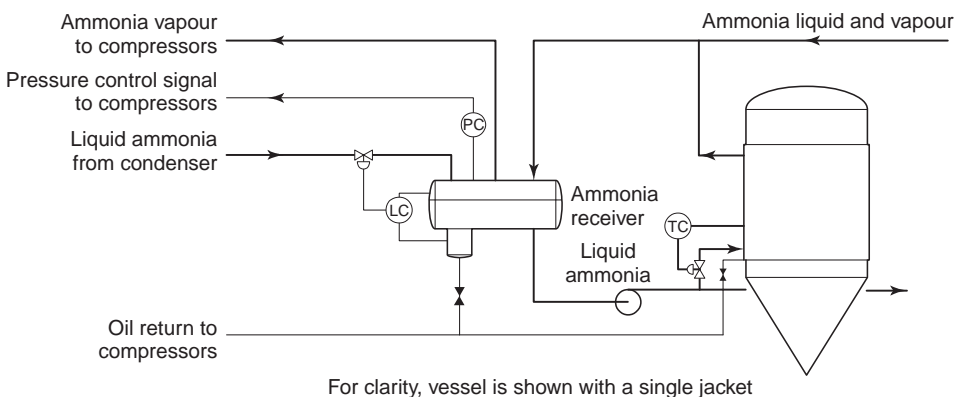

Fig. 14.5 Direct expansion cooling of a fermenting vessel; PC, pressure control; LC, level control; TC, temperature control (Anderson *et al.*, 2000).

coolant flow is achieved. The probe should be installed at a position between 30 and 50% of the height from the base of the vessel and about 500 mm (20 in.) into the vessel from the wall to avoid influence from the temperature of the wall itself. In some systems a series of probes are installed and the overall temperature computed from these inputs. However, attention to ensuring the uniformity of temperature by understanding the gradients occurring in the vessel as a result of convection cannot be too strongly stressed.

Cleaning of vessels

Cylindroconical vessels are now almost always cleaned by in-place cleaning systems (CIP). The principles of CIP are discussed in Chapter 17. CIP is expensive and potentially a major contributor to brewery variable cost. The vessels have a high organic soil level (yeast deposits) and therefore respond to cleaning with hot caustic soda (1–2%). However, to save costs the bulk of the soil should be removed with jets of water in an impact system. Various designs of impact jet are available but the most effective for fermenters are the so-called multi-planar heads in which the nozzles on the head rotate in one plane whilst the head itself rotates at right-angles on the support pipe (Fig. 14.6). Liquid should not collect in the base of the vessel or effective cleaning of this area is lost. This liquid is usually removed by scavenge pumps which must be correctly sized and have a capacity greater than the supply system and be capable of pumping with an empty supply system (self-priming). CIP cycles are now very carefully controlled by computer to optimize the use of materials and many variations can be set. A basic sequence would be based on:

- Pre-rinse with cold recovered water (say 15 °C, 59 °F) with the objective of removing as much of the soil as possible. The soiled water would pass to the effluent system. Time 10–12 minutes.
- Rinsing with hot (say 60 °C, 110 °F) caustic detergent (1–2% NaOH). Detergent will be re-circulated to a tank and will be replaced only when depleted (carbonate formed). Time 20–25 minutes.

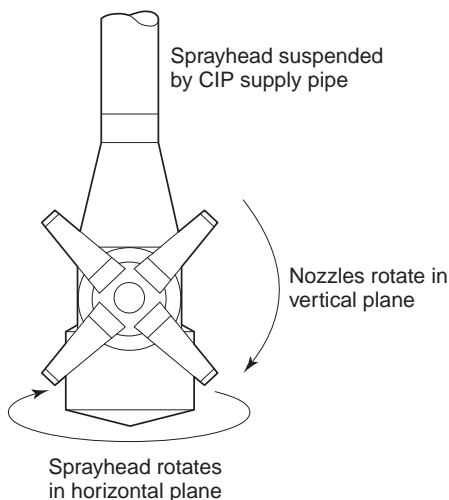

Fig. 14.6 A multi-planar CIP cleaning head (Anderson *et al.*, 2000).

- Post-rinse with clean water to remove detergent residues. A sterilant could be added at this stage (Chapter 17). Water from this stage is recovered as pre-rinse. Time 10–12 minutes.

The importance of the pre-rinse stage in minimizing detergent use cannot be overemphasized. Hot caustic soda solutions must not be applied to tanks containing carbon dioxide or rapid dissolution of the gas and implosion of the tank will follow. Vacuum relief valves (section 14.3.2) will provide some protection against this but must not be relied on as a control measure.

Acids can be used to clean fermenters. Over time beer stone (calcium carbonate/oxalate) will collect on vessel surfaces and on bends in pipe-work and sometimes in pumps. In this situation cleaning with 0.5–1.0% nitric acid or sometimes phosphoric acid is effective. Caustic detergent with a sequesterant such as EDTA (ethylene diamine tetraacetate), which strips the calcium from the stainless steel and keeps it in solution is effective but is more expensive than acid. Acid cleaning systems possibly lower the overall time of cleaning compared to systems using caustic soda (Barnes, 2001).

In fermentation vessel control systems CIP is often interlocked with a liquid level detector in the base of the tank. It is ruinous if a CIP sequence is started when beer is still in the tank. Double seat valves are therefore increasingly used in automated systems to provide security of operation and protection against leakage.

14.4 Top fermentation systems

Lager beers produced by bottom fermenting yeasts are by far the most widespread beer types throughout the world; consequently the bulk of development work on fermentation technology has been on cylindrical vessels for bottom fermenting yeasts. However in the UK and Ireland, ale and stout are the traditional beers and these are normally produced with strains of the top fermenting yeast *Saccharomyces cerevisiae* as are some Belgian and German beers. Fermentation systems developed to allow for the property of separating the yeast from the top of the fermenter at the end of fermentation. Traditional ale is cask conditioned (Chapters 21 and 23). A secondary fermentation takes place in the cask to provide condition to the beer. This ale is almost entirely produced by top fermentation. Ale can also be sold in kegs as a chilled and filtered product (Chapter 21). Some of this ale is produced by bottom fermentation in processes that are now difficult to distinguish from those of lager fermentation. Traditional ale brewers would regard producing ale by bottom fermentation with suspicion, but its proponents would cite the ease of separation of the yeast as the overriding issue.

Removal of the yeast at the end of fermentation is traditionally by manual skimming or suction of the froth or ‘head’ directly from the bulk of the fermented wort in the vessel. Developments of traditional systems have resulted in more ingenious methods for yeast separation. Examples of these methods are the Yorkshire Square system and the Burton Union system.

14.4.1 Traditional top fermentation

Vessels and rooms

Traditional top fermentation utilizes a single vessel that is open to the atmosphere to facilitate yeast removal. The vessels were traditionally shallow (2 to 4 m, approx 6.5 to

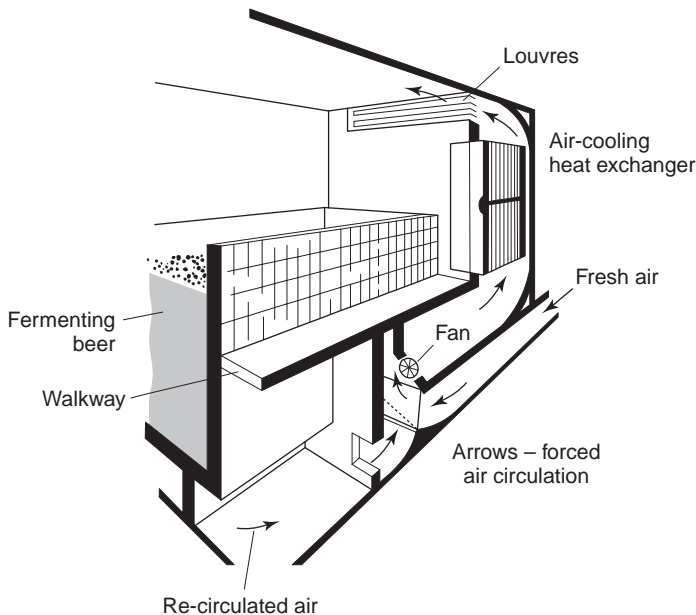

Fig. 14.7 An open square fermenting vessel (after Hough *et al.*, 1982).

13 ft. deep) and could be round, square or rectangular in shape (Fig. 14.7). Vessels have been made of many materials including wood, stone, slate, aluminium, cast iron, mild steel, copper, reinforced concrete and stainless steel. Vessels made of wood, cast iron, mild steel or concrete were usually lined with a further material to assist cleaning. Linings were made of vitrified enamel, pitch, and various plastics (with or without the incorporation of fibreglass) and epoxy resins. Nearly all these linings had adverse features, mostly the possibility of tainting the beer. Some were fragile and needed frequent repair. Almost all top fermenting vessels built since the 1960s have been made of stainless steel, usually of type 304 (Section 14.3.2).

Top fermenting vessels have traditionally been small (80 to 1000 hl; 50 to 550 imp. bbl). Vessels have normally been grouped together in fermenting rooms. To lower the risk of microbial infection the surfaces in the fermenting rooms must be smooth and also, most importantly, accessible to easy cleaning. Walls are normally tiled or finished with polypropylene sheeting and floors are tiled or covered with asphalt or terrazzo. There must be a sufficient fall on the floor to allow for drainage and the drains must be constructed with traps to avoid odours. Condensation on ceilings is often a problem as condensate can fall into the fermenting beer. To avoid this the whole fermenting room is often air-conditioned.

Normally a fermenting room has a false floor between the vessels usually about 600 to 900 mm (23 to 36 in.) below the tops of the vessels and about 2.5 m (8 ft.) above the true floor. The space between the false floor and the true floor is often called a 'shell' room. This space is utilized for circulating attemperated air and for mains and pipes. Air from above, heated by fermentation and containing carbon dioxide, can be aspirated into the shell room space, mixed with fresh air and cooled through a heat exchanger and then re-introduced above the false floor. Ideally the room should be kept at a temperature between 15 and 18 °C (59 to 64 °F).

Carbon dioxide evolved from open fermenters is a major health hazard. The maximum concentration for exposure during an eight-hour shift is set at 0.5% (sometimes called the threshold limit value, TLV) in many countries including the UK and Germany. At 1 to 2% carbon dioxide, blood composition changes and oxygen access to the brain becomes restricted. At concentrations above 2% respiration rate increases in an attempt to compensate for the shortage of oxygen and dizziness is likely to be felt. Unconsciousness and death will follow at concentrations above 8%. Many accidents arising from exposure to carbon dioxide have occurred in brewing and accidents continue to occur. It is, therefore, extremely important to take great care when working with open fermenters. Carbon dioxide, being heavier than air, will collect in the walkways between vessels as it spills over from the fermenter. A system of positive air displacement must be used to ensure that this air is removed and if re-circulated (see above) must be enriched with fresh air to lower the carbon dioxide concentration to < 0.5%. Before entering a vessel for inspection a test must be made of the carbon dioxide concentration and for the short term exposure of a tank inspection (say < 60 minutes) the carbon dioxide concentration must be not greater than 1%. More modern fermenting vessels are enclosed allowing the collection of carbon dioxide (Chapter 15) and a safer operation.

Operation

Oxygenated or aerated wort from the brewhouse is introduced into the top of the vessel. An oxygen level of 5 to 15 mg/l is aimed for. Frequently this is achieved by using oxygen but in traditional systems the wort was spread out by a fantail pipe on entering the fermenter and was so aerated. The wort is pitched as soon as possible using pressed yeast at a rate of 0.15 to 0.30 kg/hl (0.5 to 1.0 lb/imp. brl). Traditional practice is to pitch at 15–16 °C (≈60 °F) and allow the temperature to free rise to 20–24 °C (68 to 75 °F, Fig. 14.1) as fermentation proceeds. This is rapid and normally finishes in around 48 hours. Gas bubbles evolve and collect as froth on the top of the vessel, which eventually consolidates into substantial foam.

The key to success is maintaining the yeast in contact with the wort long enough to ensure adequate attenuation and flavour volatile production. This can be achieved by means of the ‘dropping’ system in which after 24–36 hours the fermenting wort is dropped by gravity into another vessel. This technique results in mixing and aeration of the wort and leaves cold break (Chapter 10) in the first vessel often called the collecting vessel. This technique can result in a beer that is easier to fine (Chapter 15). Brewers without the facility for dropping often mix and aerate wort by rousing using a pump, which returns the wort to the same vessel sometimes through a fantail. There are many different opinions about the efficacy of rousing in top fermentation but the necessity largely depends on the flocculence of the yeast. Some ale yeasts are highly flocculent and prone to early sedimentation and rousing is often essential to re-mix the yeast with the wort.

As fermentation proceeds a substantial crop of yeast collects in the foam head. This yeast is encouraged to come out of suspension by cooling and after 48 hours rapid fermentation the vessel is usually cooled to 12–15 °C (54–59 °F). Beers are sometimes left for two to three days to condition at this temperature (Chapter 15). Temperature control systems are often very basic utilizing cooling coils immersed in the vessel. These coils will be supplied with a refrigerant, which was normally calcium chloride brine but now might be IMS or propylene glycol (Section 14.3.3). Top fermenters are much smaller than cyllindroconical fermenters and as such the complexities of temperature distribution (Section 14.3.3) are not as relevant. The requirements for cooling are also much less for

top fermented ales than for lagers. More modern vessels, facilitating easier cleaning, have side wall cooling.

The yeast is removed from the vessel by skimming; this is usually by suction but was once done manually with paddles. This removal of yeast may take place once, twice or three times depending on the conditions and the type of yeast in use. The first yeast crop is frequently dirty and will contain trub, particularly if a dropping system is not in use. This crop will also be the least attenuative of that collected and it is often discarded. The following crops will be more attenuative and cleaner and these crops are usually retained for re-pitching although this relies on the experience and skill of the brewer. Yeast remaining on the base of the vessel (grounds) is normally discarded as this does not display the characteristics required for successful top fermentation, i.e., a yeast that attenuates rapidly and rises from the beer easily into the head at the completion of primary fermentation.

Yeast removed from the fermenter by suction is held in a vessel called a yeast back. In traditional systems, the yeast slurry would be processed through a filter press (Chapter 15), to separate yeast from the entrained beer, 'barm' ale, which would then be added back to the beer at racking usually after pasteurization. The yeast would be discharged from the press and held in trays or trucks in a refrigerator before re-use. The yeast can also be held without pressing, as a slurry at $< 5^{\circ}\text{C}$ (41°F), and re-used in this form. This is increasingly the practice in ale breweries because of the high labour involvement in operating yeast presses. Ale destined for cask beer (Chapters 21 and 23) is not fully attenuated in primary fermentation. Fermentable sugars remain to allow secondary fermentation to occur in the cask and thus develop condition and full flavour in the ale.

Traditional top fermenting vessels are manually cleaned after each use and this requires a high labour input in the fermenting rooms. Beers produced by top fermentation have a low carbon dioxide content of around one vol/vol (2 g/l) and this is associated with the smoothness and ease of drinking of cask ale. This is a generic characteristic of the product and is the basis on which most cask beers are sold. The labour involvement in effective yeast skimming and cleaning is thus justified. However, skimming yeast from traditional top fermenters remains a difficult process, often incurring high losses of beer and yeast. This resulted in the development of alternative systems of yeast separation to facilitate the skimming operation.

14.4.2 Yorkshire square fermentation

Vessels

Yorkshire square vessels were originally made of stone and then of slate. They were of very small capacity (50 hl or 30 imp. brl). However, modern Yorkshire squares are nearly all made of stainless steel (usually type 304) and have capacities of up to 520 imp. brl (850 hl), to match the increased brewlength of the modern brewhouse. Yorkshire squares are characterized by having a lower compartment separated from the upper open portion by a gently sloping deck (Fig. 14.8). The deck provides entry to the lower compartment by a series of pipes, known as organ pipes, and by one or two manholes (depending on the size of the vessel) with flanges around the rim. On the top of the deck is an outlet with a plug that is inserted to facilitate skimming the yeast.

Operation

The system is used mainly in the north of England and was developed for use with highly flocculent yeasts or mixed yeast strains in which one of the strains is very

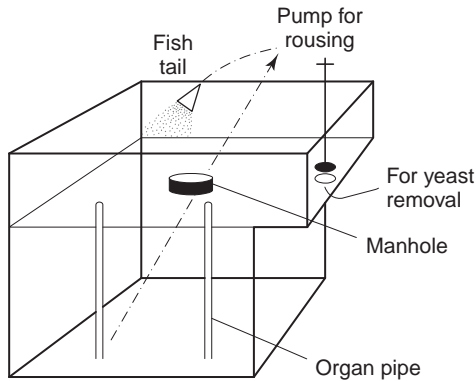

Fig. 14.8 Yorkshire square fermenting vessel (Hough *et al.*, 1982).

flocculent. Beers of characteristic flavour are produced, which often at low gravities ($< 10^{\circ}\text{P}$, 40°Sacch) have palate fullness otherwise associated with much higher gravity products. The lower compartment is filled with wort and yeast, which normally also occupies about 25 mm (1 in.) of height on the upper deck. This fill level must be carefully controlled to ensure consistent fermentation and hence a regular collection of yeast for subsequent re-pitching. As fermentation proceeds yeast rises through the manhole(s) and collects on the upper deck. The fermenting beer drains back through the organ pipes into the lower compartment. Strongly flocculent yeasts are roused by pumping to keep the yeast in contact with the beer. In systems using two yeast strains, in which one is flocculent and one is not, rousing is usually unnecessary. When the desired attenuation has been achieved rousing, if in use, stops and the yeast is removed from the top deck by skimming from the plug hole. This can be by scraping with boards or by suction. The beer is drawn from the lower compartment, usually to racking tanks, before racking into casks (Chapter 21). If the beer is to be processed as keg ale it is run for maturation into further vessels which are often cylindroconical in shape (Chapter 15).

Temperature control is similar to that used in traditional fermenters. Yorkshire squares have the advantage that the manholes can be closed and hence the under-deck area can be in-place cleaned. Traditional Yorkshire squares remain as open vessels and hence the upper deck has to be manually cleaned and the safety problems with carbon dioxide remain. The grounds (yeast and wort sediments collecting on the bottom of the vessel) are usually discarded and so the losses are high.

New developments

Yorkshire square vessels are expensive to construct and have to remain shallow, as do all traditional ale fermenters, to allow for sedimentation of the yeast not rising into the head. When centrifuges came to be used in breweries (Chapter 15) it was not necessary to achieve clarification in the fermenter and beers could be discharged to maturation as soon as sufficient attenuation was achieved. Some brewers reasoned there was no need use shallow square vessels for fermenting ale and cylindroconical vessels akin to lager fermenters have become widely used. However, some brewers remained convinced that traditional ale flavour, the characteristic of a brand, could not be achieved without fermentation in square shallow vessels. Consequently developments of the traditional Yorkshire square were sought.

Enclosed vessels have been built (Griffin, 1996; Ogie, 1997) to allow full CIP, more effective microbiological control and the potential to collect carbon dioxide gas. Of major importance has been the novel method of yeast collection reducing the manual operations of the vessels. Vacuum yeast collection tanks are connected to a pair of yeast skimming points set in the top deck of the vessel. Suction operates through these points for a set period until most of the yeast has been removed. Spray lances are then used to deliver bursts of high pressure water across the deck to direct the remaining yeast to the skimming outlets. Each burst lasts about 10 seconds and is set to ensure the yeast concentration is sufficient for re-pitching and that water consumption is kept as low as possible. The base of the fermenter is fitted with pop-up spray jets (pintle valves), which operate to remove the grounds once the beer has been run to maturation or racking. All operations are remotely controlled by computer and the vessels are essentially automatic. Thus the traditional features of Yorkshire square fermentation are maintained with the minimum of manual involvement.

14.4.3 Burton Union fermentation

This system of fermentation is associated with the Burton-on-Trent area in England and was devised for the production of pale ales with powdery, i.e., non-flocculent yeasts. Wort is collected and pitched in a collecting vessel and then transferred at the peak of fermentation (36 to 40 hours) to the set of Union vessels. These vessels are oak casks of capacity 153 imp. gallons (7 hl) arranged in two adjacent rows of 12 vessels beneath an inclined, cooled 'top' trough. The individual casks contain cooling coils. At the top of each cask is a swan-neck pipe, which can discharge into the trough (Fig. 14.9). Carbon dioxide gas carries yeast up through the swan-neck and it falls into the top trough. Yeast tends to sediment in the trough and beer collects at the lower end and is returned by side tubes to the casks. As fermentation completes virtually all the yeast has passed to the top trough. The beer in the casks is discharged into a second trough running below the row of casks and thence to racking backs. Beer transferred to racking is very clear and the yeast count is adjusted by the position of the outlet tap on each cask.

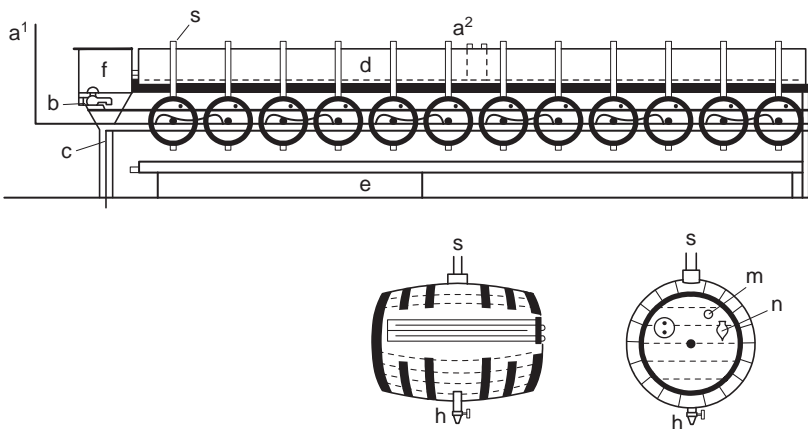

Fig. 14.9 Burton Union fermentation system (a^1) attemperaturator water (beer); (a^2) attemperaturator water (yeast); (b) side rod; (c) waste water; (d) top trough; (e) bottom trough; (f) feeder; (s) swan-necks; (h) bottom tap; (m) side tap; (n) sample tap (Hough *et al.*, 1982).

As with Yorkshire squares, beer of characteristic flavour is produced and some brewers maintain that true Burton pale ale can only be made in this way. In 1990 one company invested in a new version of the Burton Union system constructed in stainless steel comprising four sets of 30 × 150 gallon Unions. Burton Union systems require a lot of space for relatively low throughput and have a high capital cost. Labour involvement is high because, essentially, all the cleaning is manual. However, good quality yeast for re-pitching is invariably produced along with beer that is easy to fine (Chapter 15) and the opportunity is presented to exploit the method of production for enhanced marketing of the brand.

14.5 Continuous fermentation

Once the biochemistry of fermentation began to be understood towards the end of the nineteenth century (Pasteur, 1860; Chapter 13), some brewing scientists began to think they had limited control over the fermentation process. Surprisingly this stimulated a line of investigation on the continuous culture of yeast at high concentrations in which an active metabolic state was maintained and the problems of batch separation of yeast from beer avoided (Delbrück, 1892). Continuous fermentation of beer was thus attempted before 1900 and by 1906 at least five separate systems had been described, some of which were patented (Van Rijn, 1906). This patent (Van Rijn, 1906) is of some interest because in it are described processes involving the cascading of partly fermenting beer from one open tank to another, an idea that was picked up much later on in the 1950s (Wellhoener, 1954). These early systems of continuous fermentation did not achieve commercial success for reasons that are not entirely clear. It seems probable that the inability to avoid infection by micro-organisms was one reason and perhaps another was the resistance to change by the established brewers of the day.

As sales of beer increased in the 1950s and 1960s there was renewed interest in the potential of continuous fermentation particularly in New Zealand, Canada and the UK. At this time the brewing scientist was often represented at main board level in brewing companies and as such had considerable influence on company strategy. There was thus enhanced knowledge in companies of the brewing process, which could be coupled with developments in electronic process control equipment. As a result there was real hope for the commercial success of continuous systems with the advantages comprising:

- lower capital cost
- lower working capital because of less beer in process, as a result of faster throughput
- lower product cost as a result of lower beer losses, more ethanol and less yeast
- lower fixed costs because of less manpower as a result of less cleaning and automatic fermenter control.

Companies attempted to exploit the technology and gave considerable support to their scientific proponents. By the early 1970s about 4% of UK beer production was by some form of continuous fermentation and the outstanding technology of Morton Coutts was established in New Zealand (Coutts, 1957). But many of the systems fell quickly out of use and by the late 1970s and early 1980s the only production scale continuous fermenters in use were and are in New Zealand.

The decline of continuous fermentation reflected the rise in the use of the large batch cylindroconical fermenting vessel as brewers responded to the ‘threat’ of continuous fermentation by finding improved batch methods. Developments in the design and

operation of these vessels in the 1970s were rapid. At the same time the influence of marketing was becoming manifest in brewing. After a peak in brewing sales in Europe in 1979, economic recession in the early 1980s led to a search for more innovative ways of expanding beer sales. This resulted in new product development often using different yeast strains, and the desire to present the public with a greater choice of drinks. Inevitably this meant that some of these drinks were produced in low volumes and some failed to achieve market success. Many continuous fermentation systems did not have the flexibility to handle this type of production, which was much easier in batch processes. A continuous system was geared to produce a high volume of a single type of product. It was also realized that to operate continuous systems successfully required highly trained personnel often working shifts and this led, paradoxically, to increased costs. The situation was perhaps different in the less developed market conditions of New Zealand where Morton Coutts was able to foster and develop his system to commercial success over many years.

Into the 21st century the use of immobilized yeast systems has demanded a reassessment of the value of continuous fermentation and this has been allied with huge developments in process control using computers, which were not available in the 1970s and 1980s. The physiological and biochemical behaviour of yeast in continuous fermentation is discussed in Chapter 13. In this Chapter practical aspects are considered.

14.5.1 Early systems of continuous fermentation

There are a number of different ways of classifying continuous yeast culture and hence fermentation systems (Herbert, 1961; Chapter 13). Yeast can emerge in an 'open' system with the beer or in a 'closed' system when it is retained with the beer. In a homogeneous system the yeast and fermenting beer is intimately mixed in a stirred fermenter, whereas in heterogeneous systems there will be separation and concentration of the yeast away from the beer in a vessel. The cascade open system of the series of inter-connecting vessels was described in 1954 (Wellhoener, 1954). Substrate (wort) entered the first vessel and product (beer) emerged from the last. Residence time was about 25 days and the system was never fully adopted on the commercial scale. But some open systems did achieve limited production success around 1970.

Stirred tank fermenters

A system (Bishop, 1970) operated in four UK breweries achieving an output of 32,000 hl per week ($\approx 20,000$ imp. brl). There were two stirred fermenters in series and a sedimentation vessel for collecting the yeast (Fig. 14.10). Yeast was not recycled and the residence time was around 15 hours. Other UK breweries operated similar systems. The problems for further enhancement were as discussed above and to achieve outputs comparable to those of the cylindroconical vessels of the day (with a five day turn round time); the stirred fermenters would have to be increased sixfold in size. This was not commercially feasible.

Tower fermenters

Tower fermenters were developed by the APV Company in the 1960s and were used in breweries in the 1970s (Portno, 1973). This heterogeneous single vessel system (Fig. 14.11) utilized the ability of flocculent yeast strains to sediment and so maintain a high concentration of cells in the system. Wort was pumped into the base of the vertical tube. The sedimentary yeast formed a plug in the base of the vessel and the wort permeated through the plug. Some of the yeast was carried up the tower by the flow of wort and the fermentation

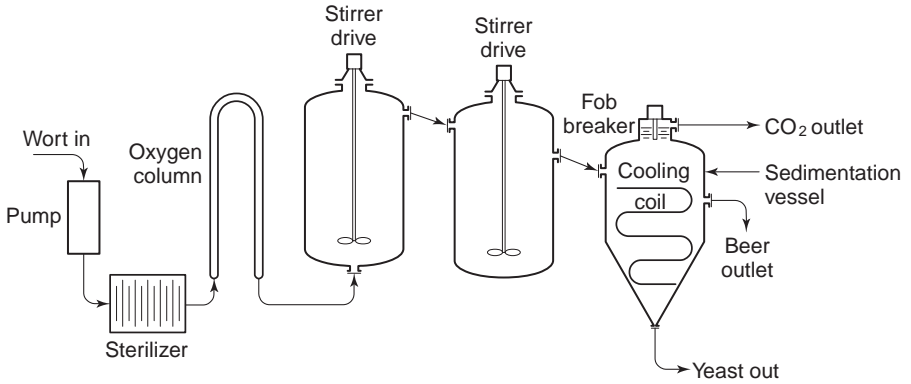

Fig. 14.10 Stirred tank continuous fermentation, two stirred fermenters in series and a yeast sedimentation vessel (Bishop, 1970).

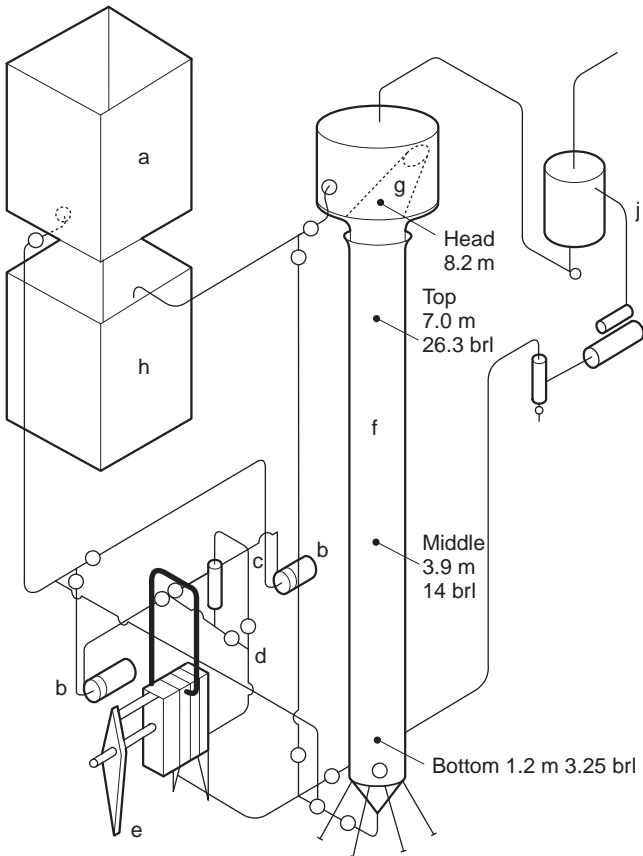

Fig. 14.11 Continuous tower fermenter; (a) wort collection; (b) impeller pump; (c) flow meter; (d) control valve; (e) flash pasteurizer; (f) tower; (g) yeast separator; (h) beer receiver; (j) CO₂ collecting vessel (after Hough *et al.*, 1982).

proceeded as the wort rose. The rate of wort injection was adjusted so that at the top of the tower the wort was fully fermented. The tower contained baffles to control the upward movement of the yeast, which can be too rapid as a result of carbon dioxide evolution in large bubbles. Yeast fell from suspension at the top of the tower and an inclined chute near the beer outflow assisted this. The system was not adaptable for the use of powdery yeast and therefore could not be used for producing beers associated with these yeasts.

It was desired to produce the same crop of yeast as with conventional fermentation so that these could be mixed if required. This required adjustments in wort composition as yeast in high concentration grows slowly and does not assimilate the normal amount of nitrogenous material from the wort. Worts with high levels of fermentable carbohydrate and low levels of assimilable nitrogen were used to yield beers of normal composition. This in turn leads to complications and increased costs in the management of the system. There were further difficulties with abnormal production of acids, esters, higher alcohols and diacetyl. Tower fermenters were also prone to infection with lactic acid bacteria requiring wort to be pasteurized before fermentation and so adding to cost. Residence times in the fermenter were as low as four hours for ale fermentations but like the stirred tank fermenters and for similar reasons, prolonged production performance was not achieved.

14.5.2 The New Zealand system

In view of the difficulties described above it is a considerable achievement that the system developed by Morton Coutts (Coutts, 1957, 1958) remains a commercial success. This is attributable to sound basic design, and unfailing commitment and skill. Significantly, the New Zealand method is an integral part of a continuous brewing system (Fig. 14.12) and it comprises:

- a hold-up vessel
- two stirred fermenters
- a yeast separator.

In the hold-up vessel the wort is aerated and mixed with yeast and beer recycled from the first fermenter. The residence time is about four hours and considerable yeast growth occurs. The volume of the hold-up tank is 230 hl (140 imp. brl) and the following fermenters are 1,637 hl (1,000 imp. brl) and 409 hl (250 imp. brl) respectively. Temperature is maintained at 15 °C (59 °F) and the throughput is 70 hl per hour. Wort of 18 °P (72 °Sacch) is fed to the hold-up vessel and is diluted in the first fermenter to 13 °P (52 °Sacch). The specific gravity of the beer emerging is about 3 °P (12 °Sacch). Total residence time is about 30 hours and continuous runs of up to one year have been achieved. The process has undergone a number of changes since its introduction (Stratton *et al.*, 1994). These have focused on improved microbiological control and process automation, which have resulted in major efficiency gains. Several plants are now operating (in 2003). This system has been a success because sound beers true to the brand type have been consistently brewed and the system has not been required to produce different beers on an intermittent basis.

14.5.3 Continuous primary fermentation with immobilized yeast

Technology

A fundamental principle of continuous culture of yeast is the maintenance of the yeast in high concentration in its substrate (Chapter 13). All continuous brewing fermentation

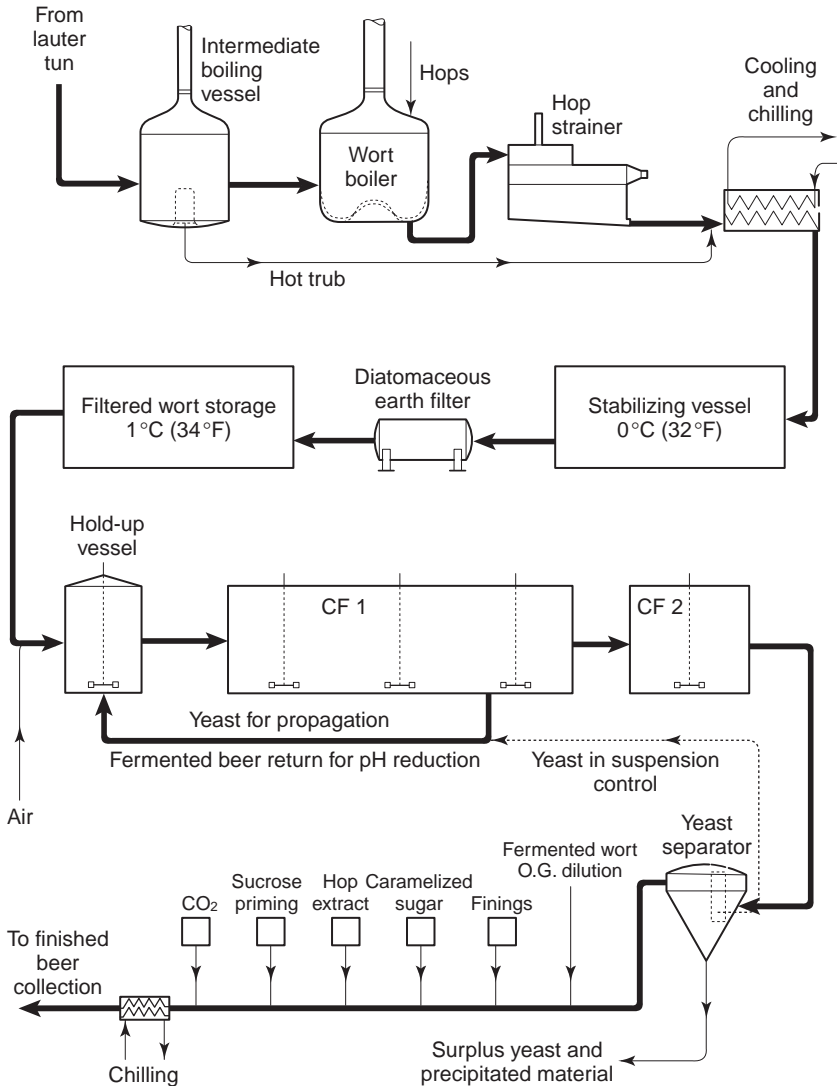

Fig. 14.12 New Zealand system of continuous fermentation, (CF1) continuous fermenter 1, (CF2) continuous fermenter 2 (Coutts, 1957, 1958).

systems must have ways of achieving this objective. However, yeast in high concentration grows slowly and the metabolic effects on the wort are different from those achieved by batch fermentation at normal yeast concentrations. This factor, together with the proneness of continuous systems to become infected with beer spoilage bacteria limited the commercial development of continuous fermentation. This situation has changed with the availability of immobilized cell technology that offers the possibility of real heterogeneous fermentation.

Immobilization involves the physical confinement or localization of whole intact yeast cells in a fixed position whilst retaining normal viability and metabolic activity (Chapter 13). The yeast cells are no longer free and therefore, in a fixed position, can be maintained in high concentration. The most common immobilization technique (Stewart

and Russell, 1998) is to trap the yeast in a matrix. This is usually a polymer that forms a gel around the cells. Many polymers have been used: alginate, carrageenan, agar, pectin, polyacrylamide and silica gel, etc. After trapping the cells on the polymer, growth in a nutrient medium takes place to ensure that the matrix is fully saturated with yeast cells. The mixture is then 'gelled' into sheets and subsequently cut into particles of desired size. Spherical beads of 0.3–3.0 mm in diameter are normally used. The matrix is porous enough to allow the free diffusion of substrates and fermentation products. The gel must have mechanical strength so that it does not split in operation and allow yeast cells to leave the matrix. This is often as a result of the evolution of carbon dioxide gas bubbles from the entrapped cells. This was a major problem in early immobilized yeast systems.

Some systems have used immobilization on pre-formed porous or non-porous supports such as kieselguhr, perlite, wood chips, PVC chips, glass fibres, stainless steel and silica. These systems reduce mass transfer problems in that the cells are in closer contact with the substrates, but they are more prone to physical disruption particularly by carbon dioxide gas bubbles. Like any other continuous system, to be commercially viable an immobilized yeast system must offer repeatable advantages over batch systems. This means considerable work to optimize immobilization procedures, and mass transfer to ensure consistently high rates of fermentation. Recent reports suggest these aims can now be achieved and that immobilized yeast bioreactors are capable of achieving rapid reproducible primary fermentation of wort over continuous periods of many months. Initially immobilized systems were primarily used for accelerated maturation of beer (Chapter 15) with rapid removal of diacetyl but now primary fermentation is achievable.

Operation

Early attempts at primary fermentation were not successful. This was partly as a result of prejudice arising from the perceived failure of free cell systems. But enthusiasts continued to experiment and received some encouragement from reports from the fuel alcohol industry (Margaritas and Merchant, 1984) which suggested reduced costs and operating consistency were achievable with immobilized yeast bioreactors. Mass transfer limits were the problem in early immobilized technology (Masschelein *et al.*, 1985) and it proved difficult to produce beers directly flavour matched to beers from batch fermentations. This was partly owing to the use of worts with too low levels of free amino nitrogen (FAN) resulting in unbalanced concentrations of higher alcohols and esters. There was also low oxygen tension in early immobilized systems which was advantageous for ethanol production but not for the balance of beer flavour volatiles.

In a Japanese two-stage process a free cell stirred fermenter is followed by an immobilized yeast bioreactor (Inoue, 1995). Yeast growth occurs in the stirred vessel, which allows appropriate utilization of FAN similar to that of conventional batch fermentation. Full attenuation was then achieved in the anaerobic bioreactor where the yeast cells were trapped on porous ceramic beads. Centrifugation of the beer between the two stages was often carried out. The system was combined with a maturation column (Chapter 15) to complete beer production in three to five days. From a 20-litre pilot plant, scale up to 100 hl has been achieved which has operated for two years. Whilst the system was resistant to bacterial infection it did not achieve the efficiencies hoped for and it did not offer significant improvement over batch fermentation. Capital costs were higher than anticipated and so were revenue costs as a result of higher beer losses in centrifugation and increased energy usage.

A novel approach to solving the problem of efficient mass transfer has been developed in Canada (Mensour *et al.*, 1997). This system utilizes a gas lift draft tube bioreactor (Fig.

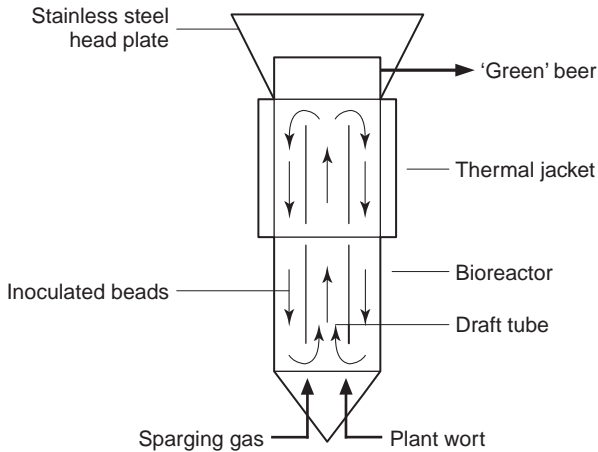

Fig. 14.13 Gas lift draft tube bioreactor (Mensour *et al.*, 1997).

14.13) with carrageenan gel beads. Good mixing is achieved with minimum shear on the matrix; hence mass transfer is considerably improved. A mixture of air and carbon dioxide was used as the sparging gas. The proportion of air affected the flavour profile of the resulting beer and by taste panel evaluation air concentrations of between 2–5% yielded acceptable products though not precisely matched to conventionally fermented beer. Again the system can be combined with accelerated maturation to produce finished beer in two days.

An alternative two-stage process has been developed in Belgium (Masschelein and Andries, 1996). The immobilized yeast bioreactor precedes a cylindrical stirred tank. The yeast is immobilized in rods of porous sintered silicon carbide of length 900 mm and diameter 26 mm. Fermenting beer is circulated through the internal channels of the carbide rods. Green beer is drawn from the top of the reactor to the stirred tank in which it can also be circulated from the tip of the cone to a point on the cylinder just above the start of the cone. The fermentation in the stirred tank is completed by yeast cells, which have escaped from the immobilized bioreactor. Beers of acceptable flavour have been produced at rates of 135 hl/hl of fermenter volume over a continuous period of six months.

Further developments have been reported from Finland (Andersen *et al.*, 1999; Pajunen *et al.*, 2000) where there has been considerable progress on achieving satisfactory maturation with immobilized yeast (Chapter 15). This work has concentrated on solving the problems associated with temperature control and the disruptive effect of carbon dioxide gas bubbles on the stability of the matrix. A single reactor is used operating at a high enough pressure to keep carbon dioxide gas in solution. The gas is removed in a separate de-gassing unit and the beer is circulated around the fermentation/de-gassing loop to complete attenuation. The heat generated in fermentation is removed with a heat exchanger. The system has operated in pilot scale at 50 litres per hour to yield beer in 20 hours.

Future

Work on continuous fermentation with immobilized yeast bioreactors is characterized by the great innovation and enthusiasm of its devotees. Nevertheless, problems remain over the widespread adoption of the technique. Rapid fermentation tends to result in the

production of higher levels of diacetyl than are normal in brewery fermentations. This diacetyl can be removed using immobilized yeast technology (Chapter 15). Some brewers view this as an extra, avoidable process and are deterred from using continuous rapid primary fermentation. This does not detract from using immobilized yeast for rapid diacetyl removal in maturation. The use of a genetically modified yeast could overcome this problem of increased diacetyl production but this is unlikely to achieve public acceptance for some time, if ever. The external addition of α -acetolactate decarboxylase would also help but some brewers wish to avoid the use of added enzymes.

There is also the problem of the diversity of brands produced by some brewers. If the production of different beers requires the use of different yeasts then the inflexibility of continuous fermentation is manifest. Successful continuous fermentation requires the steady production of a single brand with great consistency (Section 14.5.2). To achieve the undoubted potential benefits of continuous fermentation would require different brands to be produced from varying wort composition or from treatments post-fermentation.

Optimistic conclusions for the future were drawn in an EBC symposium on immobilized yeast reported in 1997 (Linko *et al.*, 1997), nevertheless in the same year 99.9% of the World's beer was produced in batch fermentation systems (Masschelein, 1997).

14.6 Fermentation control systems

The control of temperature in fermentation has received much attention (Section 14.3.3). These control systems are reactive to the exothermic nature of fermentation and are now highly developed. However, until recently little attention has been paid to the control of brewery fermentation in relation to the chemical changes which are taking place. These changes include the fall in specific gravity and in pH value of the wort and the production of ethanol and carbon dioxide.

In the general literature of biotechnology the control of industrial fermentations to yield many products is considered in depth. Brewers have not always made best use of this information, but any control system, no matter how innovative, must justify itself in terms of its cost effectiveness for the production of potable beer (Moll, 1983; Dauod, 1987).

14.6.1 Specific gravity changes

The most widely investigated methods of fermentation control have been based on the fall in specific gravity as wort is fermented to yield beer. In its most basic form this method involves taking a representative sample of wort and measuring its attenuation limit using, e.g., EBC Analytica IV method. This can be done throughout fermentation to construct a time-course picture of attenuation during the fermentation process (Section 14.2.2). The system can be automated such that the density of the wort is determined by direct methods (Fig. 14.14); this is, of course, a system of automated measurement rather than control. Wort density could also be measured by refractometry or by the use of the oscillating U-tube. These methods have been developed into control systems when the fall in gravity has been used to cause an external change such as the onset of fermenter cooling. This has the potential of earlier use of cooling and hence savings in process time.

In large cylindrical fermenters pressure difference measurements have been used to monitor the density change. As sugars are fermented to ethanol and to carbon dioxide

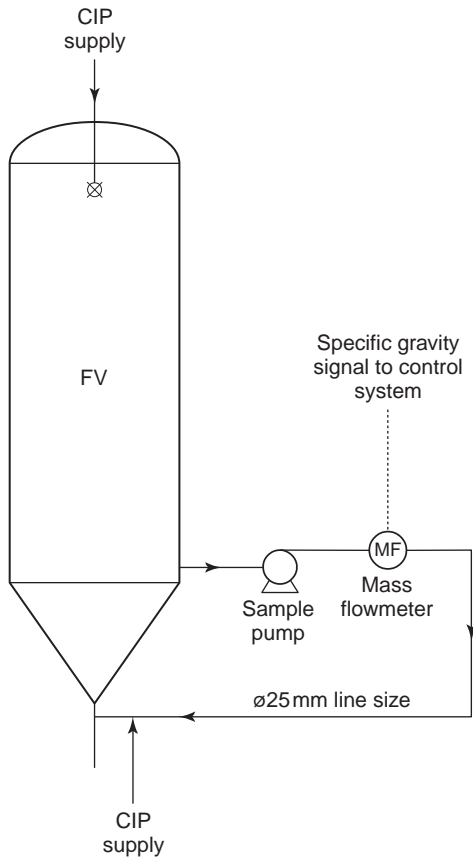

Fig. 14.14 Specific gravity monitoring system using a sample loop; the product sampled is fermenting wort in the specific gravity range 1000–1100°Sacch, a signal is sent from the mass flowmeter to the control system, sample pump must operate in both directions to allow for CIP; (FV), fermenting vessel (Barnes, 2001).

so the density drops and the pressure in the fermenter will change in proportion. Pressure transducers are used to measure this change and by linking to a computer the extent of fermentation can be followed. This technique has also been applied in new Yorkshire square fermenters (Griffin, 1996).

14.6.2 Other methods

It was demonstrated in the 1970s (Alford, 1976) that the partial pressure of carbon dioxide in exhaust fermenter gas was an excellent approximation to the partial pressure exerted by dissolved carbon dioxide in the liquid in the fermenter. This provided the basis for a potential control system to assess the extent of fermentation by measurement of carbon dioxide partial pressure in the exhaust gas. A control method relating to the production of carbon dioxide has been described (Daoud *et al.*, 1989), but has not achieved widespread adoption.

The use of dielectrical permittivity for the control of yeast pitching rate has already been discussed (Section 14.3.3 and Chapter 13). The commercially available probe can also be used to detect viable yeast cells in streams of yeast emerging from the cone of

cylindroconical vessels during cropping (Boulton and Clutterbuck, 1993). This biomass probe can be used in-line to automatically control yeast removal from the fermenter at the end of fermentation. The proportion of the yeast crop most suitable for re-pitching can therefore be retained. This technique could also be of direct financial benefit in allowing the reduction of yeast storage capacity.

Methods of fermentation control involving the measurement of pH value are also available (Barnes, 2001). A sample is withdrawn from the fermenter the pH is measured and, if it is too high, oxygen can be introduced to the fermenter automatically. This can be further linked into modulation of the coolant control valves to direct the temperature in the fermenting vessel. Possibly, future developments in fermentation control will focus on assimilating a number of measurements: density, carbon dioxide production, ethanol production, pH value into a computer and causing outputs to achieve automatically the desired time course of the fermentation. This will mainly result in improvements in the control of cooling by better modulation of coolant valves, with consequent savings in energy. The capital cost of such systems will, however, be high and anticipated paybacks must be carefully assessed before proceeding with installation.

14.7 Summary

The major developments in fermentation technology in the latter part of the 20th century and into the present day have focused on the cylindroconical fermenting vessel, which has been operated in batch sizes of up to 6,000 hl (3,600 imp. brl). The development of the vessel has reflected the increased dominance in the brewing world of beers produced by bottom fermenting yeasts. Recent developments of the cylindroconical vessel have included improvements in yeast pitching control to maximize the pitching of viable yeast and improved temperature control and cleaning. Overall fermentation control systems, where changes in the state of the fermenter can be effected automatically arising from the measurement of primary fermentation parameters such as density, are not in wide use. The difficulty of achieving cost effectiveness in this area provides encouragement for the proponents of continuous fermentation technologies.

Continuous primary fermentation with free cell systems is difficult to exploit consistently and commercially. Large volumes of an established brand in a consistent market, and skill and enthusiasm of operators are needed for success. This has been achieved only in New Zealand. Immobilized yeast technology would seem to be the most likely continuous system for widespread applicability. Extremely rapid fermentation is achievable (20 hours) and this can be allied to rapid maturation also with immobilized yeast. However, a problem remains, the perceived inflexibility of continuous systems and inability to deal with a range of beer brands requiring different yeasts. Nevertheless developments in the use of immobilized yeast for continuous primary fermentation will occur, as there is real potential for major reduction in brewery variable cost when this technique succeeds.

14.8 References

- ALFORD, J. S. (1976) *Can. J. Microbiol.* **22** (1), 52.
 ANDERSEN, K., BERGIN, J., RANTA, B. and VILJAVA, T. (1999) *Proc. 27th Congr. Eur. Brew. Conv., Cannes*, 771.

- ANDERSON, R. G., BRITES SANCHES, A., DEVREUX, A., DUE, J., HAMMOND, J., MARTIN, P. A., OLIVER-DAMEN, B. and SMITH, I. B. (2000) *Fermentation and Maturation Manual of Good Practice*, European Brewery Convention, Zoeterwoude, The Netherlands.
- ANDREWS, J. M. H. (1997) *Ferment*, **10**, 309.
- BARNES, Z. C. (2001) Personal Communication.
- BISHOP, L. R. (1970) *J. Inst. Brewing*, **76**, 173.
- BOULTON, C. A. and CLUTTERBUCK, V. J. (1993) *Proc. 24th Congr. Eur. Brew. Conv. Oslo*, 509.
- CARVELL, J., ODDI, L. and HARDING, C. (1998) *Proc. 25th Conv. Inst. Brew. (Asia Pacific Section), Perth*, 201.
- CHRISTIAN, A. H. R. (1959) *Brewers' Guard*, **88**, 43.
- COUTTS, M. W. (1957) *British Patents*, 872391–872400.
- COUTTS, M. W. (1958) *Australian Patent*, AU 216618.
- DAUOD, I. (1987) *Brewers' Guard*, **116** (6), 14.
- DAUOD, I., DYSON, R., IRVINE, J. and CUTHBERTSON, R. C. (1989) *Proc. 22nd Congr. Eur. Brew. Conv., Zurich*, 323.
- DELBRÜCK, M. (1892) *Wochensch. Brau.*, **9**, 695.
- FRICKER, R. (1978) *Brewers' Guard*, **107**, 28.
- GRIFFIN, S. R. (1996) *Brewers' Guard*, **125** (8), 12.
- HERBERT, D. (1961) *Continuous Culture of Microorganisms*, SCI Monograph, SCI London, **12**, 21.
- HOGGAN, J. (1977) *J. Inst. Brewing*, **83**, 133.
- HOUGH, J. S., BRIGGS, D. E., STEVENS, R. and YOUNG, T. W. (1982) *Malting and Brewing Science 2nd Edition Volume 2*, Aspen, Gaithersburg, Maryland.
- INOUE, T. (1995) *Proc. 25th Congr. Eur. Brew. Conv., Brussels*, 25.
- INSTITUTE OF BREWING ANALYSIS COMMITTEE (1971) *J. Inst. Brewing*, **77**, 181.
- KNUDSEN, F. B. and VACANO, N. L. (1972) *Brewers' Digest*, **47** (7), 68.
- LEMER, C., TAEYMANS, D. and MASSCHELEIN, C. A. (1991) *Proc. 23rd Congr. Eur. Brew. Conv., Lisbon*, 329.
- LINKO, M., VIRKAJAVI, I., POHJALA, N., LINBORG, K., KRONLOF, J. and PAJUNEN, E. (1997) *Proc. 26th Congr. Eur. Brew. Conv., Maastricht*, 385.
- MAHLER, H. R. and CORDES, E. H. (1969) *Biological Chemistry*, New York, Harper-Row.
- MARGARITAS, A. and MERCHANT, F. (1984) *Crit. Reviews in Biotechnology*, **1**, 339.
- MASSCHELEIN, C. A. (1997) *J. Inst. Brewing*, **103**, 103.
- MASSCHELEIN, C. A. and ANDRIES, M. (1996) *Brew. Distill. Internat.* **27** (7), 16.
- MASSCHELEIN, C. A., CARTIER, A., RAMOS-JEUNNEHOMME, C. and ABE, L. (1985) *Proc. 20th Congr. Eur. Brew. Conv., Helsinki*, 339.
- MAULE, D. R. (1976) *The Brewer*, **62** (5).
- MAULE, D. R. (1977) *The Brewer*, **63** (6), 204.
- MAULE, D. R. (1986) *J. Inst. Brewing*, **92**, 137.
- MENSOUR, N. A., MARGARITAS, A., BRIENS, C. L., PILKINGTON, H. and RUSSELL, I. (1997) *J. Inst. Brewing*, **103**, 363.
- MOLL, M. (1983) *Proc. 19th Congr. Eur. Brew. Conv., London*, 272.
- NATHAN, L. (1930) *J. Inst. Brewing*, **36**, 538.
- OGIE, P. J. (1997) *Brew. Distill. Internat.*, **28** (6), 32.
- PAJUNEN, E., RANTA, B., ANDERSEN, K., LOMMI, H., VILJAVA, T., BERGIN, J. and GUERCIA, H. (2000) *Proc. 27th Conv. Inst. Brew. (Asia Pacific Section), Singapore*, 91.
- PASTEUR, L. (1860) *Annales de Chimie et de Physique*, 3^e Serie, **58**, 323.
- PASTEUR, L. (1876) *Etudes sur la bière*, Paris, Gauthier-Villiers.
- PORTNO, A. D. (1973) *Brewers' Guard*, **102** (7), 33.
- STEWART, G. G. and RUSSELL, I. (1998) *Brewer's Yeast*, Institute of Brewing, London.
- STRATTON, M. K., CAMPBELL, S. J. and BANKS, D. J. (1994) *Proc. 23rd Conv. Inst. Brew. (Asia Pacific Section), Sydney*, 196.
- TEASS, H. A. (2000) *Tech. Quart. MBAA*, **37** (1), 37.
- VAN RIJN, L. A. (1906) *British Patent*, 18045.
- WELLHOENER, H. J. (1954) *Brauwelt*, **94**, 44, 624.

Beer maturation and treatments

15.1 Introduction

Beer, at the completion of primary fermentation is said to be 'green'. It contains little entrained carbon dioxide, it is hazy and its taste and aroma are inferior to beer that is ready for sale. In order to refine green beer it must be matured or conditioned. This maturation process takes place in closed containers in the brewery and beer treated in this way is called brewery conditioned beer. This is most of the beer produced and sold in the world, the exception being cask conditioned beer produced primarily in the UK (Chapter 21). The process, also called 'lagering' when referring to bottom fermented beers, used to occupy several weeks or even months, but now is often completed in one to two weeks and sometimes in considerably less. It follows that accelerated processes of maturation have been developed. Traditionally, maturation involves a secondary fermentation and is effected by the small amount of yeast remaining in the beer when it is transferred from the fermenting vessel. This yeast can utilize fermentable carbohydrates remaining in the beer at the end of primary fermentation or small quantities of fermentable carbohydrate added in the form of 'priming sugar'. In some systems wort is added to provide the fermentable material or actively fermenting wort when the process is called 'krausening'. The carbon dioxide that is produced dissolves in the beer because the vessel is closed and the beer becomes 'conditioned'. Other gases and volatile substances are produced during maturation which are deleterious to beer flavour, e.g., hydrogen sulphide and some diketones. Occasional, but systematic, release of pressure on the maturation vessel will allow the venting of these compounds to atmosphere.

Green beer is hazy as well as having an unacceptable flavour. During maturation, clarification of the beer takes place. This is by natural sedimentation in the cold ($\leq -1^{\circ}\text{C}$, 30°F) of protein and polyphenol complexes, but this process can be enhanced and considerably hastened by physical and chemical means and this is now common brewery practice. Stabilization of the beer is also an important aspect of maturation. The objective is to ensure that turbidity owing to chemical precipitation or growth of micro-organisms does not occur or, in the case of chemical precipitation, does not recur when the beer is clear and stable. During maturation, treatments can be made to the beer to

adjust its flavour and colour by the use of caramel or other colouring materials and by the use of various post-fermentation hop treatments for both bitterness and aroma.

The final treatment for beer before packaging is filtration and beers which have been effectively matured and stabilized by whatever means are easier to filter. This is of importance in large breweries where interruptions in beer filtration are extremely damaging to overall efficiency. The separation of sediment or 'tank bottoms' from the maturing beer either by, or before filtration is, therefore, crucial to success. The disposal of this sedimented material is becoming a problem in some areas, e.g., the UK.

Beers brewed at higher than sales gravity are diluted before packaging and this often occurs after maturation but under the same departmental control. The department in the brewery in which maturation and clarification is carried out is often referred to as the process department. Beer changes or treatments after primary fermentation but before packaging therefore comprise:

- maturation; flavour and aroma changes
- stabilization against non-biological haze
- carbonation
- biological stabilization (pasteurization or sterile filtration, Chapter 21)
- clarification and filtration.

Certain special beer types can also derive from further treatments post fermentation. These include low-alcohol and non-alcoholic beers and so-called ice beers.

15.2 Maturation: flavour and aroma changes

The flavour changes that take place as a beer matures are profoundly important in developing the character and hence the brand identity of the beer. Successful brands generally have stable flavours and so can be recognized by consumers. This applies to national and international brands but even local brands will be expected to display consistent taste. Flavour improves during the maturation process but this flavour improvement is difficult to characterize and optimize. There is the added factor of the effect of oxygen, which will generally cause adverse flavour changes, and so any discussion of flavour maturation must include a study of ways of preventing oxidation. Maturation is carried out in many different ways and it is difficult, therefore, to establish the underlying principles. What is clear is that processes of secondary fermentation and subsequent cold storage are involved that frequently took several months but now are usually completed in around two weeks or less, so investment in the fixed assets of storage tanks has been reduced.

15.2.1 Principles of secondary fermentation

Secondary fermentation permits continued activity by the yeast at a reduced rate limited by the low temperature and the lower yeast count in the beer. Traditionally after primary fermentation (Chapter 12) the beer would pass to the conditioning or maturation vessel and would contain 1–4 million yeast cells/ml of beer and about 4° of gravity (1.1% fermentable extract). There are many temperature regimes which are subsequently applied, and they represent compromises between promoting production of carbon dioxide and hence providing condition to the beer and allowing the removal of undesirable flavour compounds. The beer was cooled, traditionally to 8 °C (46 °F) at the

end of primary fermentation to remove most of the surplus yeast before transfer to the warm maturation vessel. In this process the remaining yeast becomes re-suspended and there is a small uptake of oxygen, which activates the yeast to start the slow secondary fermentation. This results in the conversion of many unwanted flavour compounds into flavourless products (O'Rourke, 2000).

Flocculent yeasts separate easily at the end of primary fermentation and conditions can be adjusted such that sufficient yeast can be retained in the beer to effect the flavour changes required in maturation (Chapter 12). Powdery yeasts, not separating effectively, may ferment too fully in secondary fermentation and remove all residual extract and may remain in suspension making clarification difficult. These different situations provide constant challenges to fermentation and maturation management. In any event the yeast must have access to fermentable carbohydrate for the process to succeed. This carbohydrate is provided, as above, by residual gravity in the beer or by the addition of sugar by priming or by krausening. Krausening is the addition of wort from the active 'krausen' stage of the primary fermentation usually at 5–10% by volume of the green beer. In shorter secondary fermentation regimes yeast activity must be intense to achieve carbonation, purging of the undesirable volatiles, removal of all residual oxygen and chemical reduction of many compounds. This leads to immediate improvement of flavour and aroma and flavour stability.

15.2.2 Important flavour changes

Several important groups of compounds have been identified as changing during the maturation of beer with consequent positive effect on beer flavour. The most important are: diketones (especially diacetyl), sulphur compounds, aldehydes, and volatile fatty acids.

Diketones

Diacetyl and 2,3-pentanedione are produced in all brewery fermentations (Chapter 12). Diacetyl in particular has an intense sweet, butterscotch flavour. This cannot be tolerated in lager beers and the concentration in finished beer should be < 0.1 mg/l. A period of warm conditioning (2–3 days at 14–16°C, 59°F) is very effective in reducing the diacetyl content of beer. The precursors of diacetyl and 2,3-pentanedione, α -acetolactate and α -acetohydroxybutyrate, are excreted by the yeast and are non-enzymically converted in the green beer to the vicinal diketones by oxidative decarboxylation. The level of the acetohydroxy acids in beer is a function of the yeast strain and is enhanced by conditions of rapid yeast growth. Yeast cells will not assimilate exogenous acetohydroxy acids but will readily take up and reduce diacetyl and 2,3-pentanedione to acetoin and 2,3-pentane diol, which have no adverse flavours. The rate of this reaction is dependent on the yeast strain, how it has been stored, and its age. This forms the basis of effective diacetyl removal from green beer; the yeast must be in a healthy metabolic state to carry out the reduction efficiently. Frequent causes of inability to control the concentration of vicinal diketones in beer are yeast of the wrong strain or yeast in poor health perhaps accelerated by the too rapid onset of fermenter cooling, causing the yeast to separate. If active yeast is not present diacetyl will not be reduced.

The effective and reproducible removal of vicinal diketones from beer is important in overall brewery efficiency. Delays in diacetyl removal result in delays in filtration and hence delays in the supply of beer to packaging. This has stimulated work to examine ways of accelerating the removal of diketones. The most effective way remains the

choice of an appropriate strain of yeast. However, in some cases strains are used which have other desirable properties but are inherently poor at diketone removal. The use of a commercially available α -acetolactate decarboxylase enzyme has been proposed (Hanneman, 1999). It was shown, in tube fermentations and full-scale brewery trials, that maturation was accelerated and the need for cold beer lagering eliminated or reduced to an absolute minimum. The optimal dose of enzyme depends on the yeast strain and wort composition. The enzyme is derived from *Bacillus subtilis*, which contains a gene from *Bacillus brevis*. The enzyme is now used in many parts of the world (Jepsen, 1991). It is not approved for use in the UK.

A novel method of maturation, allowing very rapid reduction of the diacetyl content, has been described using immobilized yeast in a bioreactor (Pajunen *et al.*, 1991; Pajunen and Jääskeläinen, 1993, see Chapters 13 and 14). Yeast cells are immobilized on beads of DEAE-cellulose (diethylaminoethylcellulose). The brewing yeast is first separated from the green beer by centrifugation to give a very low yeast count. It is then heated to 90 °C (195 °F) for 8–10 minutes to convert all the α -acetolactate to diacetyl. The beer is then passed through the immobilized yeast reactors and the diacetyl is converted to acetoin. The beer is then ready for filtration and packaging. The technique has been used commercially (Pajunen and Jääskeläinen, 1993) to operate at an annual volume of one million hl. In this system there are four bioreactors with a maximum total flow of 14 m³/h, which corresponds to the centrifuge capacity and the time needed for rapid emptying of primary fermenters. In this system the maturation process is reduced to a matter of hours (frequently < 5 h) compared to at least seven days by conventional methods. It seems likely that other brewers will investigate the use of immobilized yeast for this purpose.

Accelerated removal of diketones lowers the capital expenditure needed on vessels and lowers the working capital of beer in manufacture in the brewery. There should also be greater flexibility to meet customer demand if maturation times are consistent and short.

Sulphur compounds

The metabolism of sulphur in brewery fermentations was discussed in Chapter 12. Sulphur compounds are important in the overall flavour of a beer in spite of their very low concentrations. Changes in the level of sulphur compounds do occur in maturation but this is incompletely understood. Generally, undesirable concentrations of hydrogen sulphide are reduced during cold storage times of 5–7 days. Sometimes, using krausening, there is over production of hydrogen sulphide depending on the proportions of threonine and methionine brought forward from the primary fermentation. It was reported that the sulphury note on beer was reduced using the immobilized yeast bioreactor compared to conventional maturation (Pajunen and Jääskeläinen, 1993).

It has been suggested that the best sulphur marker for following maturation is the concentration of DMS (dimethyl sulphide). However, the level of DMS in beer can be dependent on different mechanisms in different breweries. Often of major importance is the conversion of S-methyl methionine (SMM) to DMS in wort boiling and the effect of the hot wort stand time and the vigour of the boil on the relative proportions of SMM and DMS (Dickenson and Anderson, 1981). DMS can arise during fermentation to a limited extent from the reduction of dimethyl sulphoxide (DMSO), (Anness, 1980). Determinations of DMS concentration can be made during maturation with the objective of achieving the desired level for the final beer. This level, however, varies considerably for different beers. The flavour threshold of DMS is 35–40 $\mu\text{g/l}$ (Brown *et al.*, 1978), and each brewery should know what level it is aiming for.

There has been some discussion about the purging effect on volatiles of the carbon dioxide produced during beer maturation. There is some evidence that hydrogen sulphide is more effectively purged from beers where carbon dioxide production is vigorous (Zangrando and Girini, 1969).

Aldehydes

Acetaldehyde in particular can affect beer flavour. This arises from the oxidation of ethanol and can occur if transfer of the beer from primary fermentation to maturation is carelessly carried out giving the opportunity for oxygen uptake by the beer. During normal maturation the acetaldehyde concentration will decrease to 2–7 mg/l. Acetaldehyde can be detected at about 10 mg/l in a lightly flavoured pilsen-type beer, when it gives a flavour of green apples. It is less easily detected in ales and is a characteristic of some ale flavours. Concentrations of > 35 mg/l should be avoided.

Volatile fatty acids

Beer conditioning temperature is very important in determining the excretion of C₄ to C₁₀ fatty acids. Synthesis of short chain fatty acids by yeast stops at the onset of maturation. C₈ fatty acid increases in concentration during fermentation and this is replaced in maturation by C₁₀ acid. Glycerides and phospholipids are synthesized during maturation and so there is a general trend for a reduction in volatile acids as ageing proceeds. This trend can be reversed if maturation is extended too far. There can then be a rise in the concentration of free fatty acids owing to the hydrolysis of reserve glycerides, with consequent adverse effects on flavour. If a high maturation temperature is maintained for too long then there can be a slow excretion of C₁₀ acid (capric acid), which has a flavour threshold of 10 mg/l and this is undesirable. Maturation is seldom controlled specifically from the viewpoint of controlling volatile fatty acids. Provided that the warm conditioning is not extended beyond the time needed to reduce the concentration of vicinal diketones, and cold storage is controlled to the time required for stabilization of haze precursors, there should not be a problem.

15.2.3 Techniques of maturation

Technique varies widely from brewery to brewery. In general, for bottom fermented beers the technique must ensure the production of a balanced beer flavour with the minimum concentration of diacetyl. For brewery conditioned top fermented beers, the technique centres around creating the required haze stability as the more robust flavour of the top fermented ale derives from primary fermentation and diacetyl reduction is not a problem.

Lager methods

Beer is transferred to a separate tank for maturation in traditional lagering methods. Before the end of primary fermentation cooling is applied to the cone of the fermenter to achieve a temperature of 5 °C (41 °F). The remainder of the beer above the cone (at least 95% of the volume) is at a higher temperature to ensure effective diacetyl removal. Cooling below 5 °C (41 °F) is not necessary and runs the risk of cooling the beer beyond its point of maximum density when inversion of flow around the fermenter may occur (Andrews, 1997). About 24 hours after applying cooling an initial removal of yeast is usually carried out. This yeast is usually discarded. When diacetyl reduction is complete the remainder of the beer is slowly cooled to 5 °C (41 °F) to complete the maturation by adjusting the flavour volatiles. A sudden fall in temperature must be avoided or the shock

may induce the yeast to excrete protease enzymes that could be detrimental to foam stability. This cooling may take from two to nine days. At the end of this period a second removal of yeast is usually made. The beer is now completely cooled to at least -1°C (30°F). The period of colloidal stabilization now takes place at -1 to -2°C (30 to 28°F) for two to three days. A final yeast removal is made before filtration. The colloidal stabilization temperature must be maintained throughout the whole vessel.

There are many variations on this technique which would still be regarded as traditional. Indeed the times can be much longer (Miedaner, 1978) with storage times at -1°C (30°F) being up to six weeks. In this situation up to 40% of the capital cost of the brewery could be in the tanks required to condition beer (Coors, 1977). Fermentation and maturation can also be carried out in one vessel so avoiding transfer between primary and secondary fermentation.

Because of the high capital costs associated with building tanks and the working capital of stored beer, brewers have sought to reduce maturation times. Yeasts with the ability to reduce diacetyl rapidly have been used and warm storage times have been almost eliminated. There are almost as many variations on maturation technique as there are breweries. At least one successful system comprises: fermenter filling 20 hours, primary fermentation 72 hours, warm storage 48 hours, cooling 48 hours, cold storage at -1°C (30°F) 36 to 48 hours. Total time is less than ten days. These systems can produce sound beer. However things can go wrong and they are susceptible to variations in raw material quality. To escape from periods of uncertainty over maturation and hence flavour stability, brewers need to keep in mind the traditional principles of the process. One of the most successful systems for reducing maturation time seems to be the system of using immobilized yeast in a bioreactor (Section 15.2.2).

Ale methods

The traditional method for maturation and conditioning of ale is cask conditioning (Chapter 23). Now many types of ale are brewery conditioned and filtered and sold in kegs (Chapter 23). Ale fermentations are rapid and vigorous and usually completed in 48 to 60 hours (Chapter 12) at temperatures of up to 24°C (75°F) before being cooled to $< 10^{\circ}\text{C}$ (50°F) as rapidly as possible to encourage yeast separation. A period of warm conditioning for a brewery conditioned beer can take place in the fermenting vessel at around 15°C (59°F) before cooling and transfer to the maturation vessel. Diacetyl reduction is not a problem and low levels of diacetyl (0.1 mg/l) are a constituent of some ale flavours. Brewery conditioning of ales focuses on cold treatment to 'fix' the flavour of primary fermentation and to ensure the elimination of haze precursors. Yeast is removed by skimming from the top of the fermenter at the end of primary fermentation and the beer is conditioned at -1°C (30°F) for 48 to 120 hours.

Oxygen control

Beers are often required to have flavour and haze (Section 15.3) shelf-lives of up to 52 weeks even when stored under adverse conditions. The deterioration of flavour is dealt with in Chapter 20. It is vital, in order to ensure flavour stability, that ingress of oxygen is minimized after anaerobic alcoholic fermentation for the production of brewery conditioned beers. In cask conditioned beers yeast protects the beer against the adverse effects of oxygen.

The uptake of oxygen into beer is primarily a function of the difference in partial pressure between the beer and the gas in contact with it. Minimizing this is the basis of successful oxygen control. Turbulence during beer movements must be avoided.

Turbulence causes the loss of carbon dioxide and the uptake of oxygen. Beer must therefore be moved gently through correctly sized pipes.

Movement of beer from one tank to another, e.g., from fermenter to maturation vessel is often encouraged by applying top pressure of carbon dioxide to the donor tank after flushing the mains and the receiving tank with the gas. But carbon dioxide is expensive and the cheaper nitrogen gas is now often used. The high density of carbon dioxide, relative to air, can be exploited. A thin blanket of carbon dioxide can be produced above the beer in the donor tank, and a top pressure of air can be used to move the beer out of the tank. A small amount of carbon dioxide can then be injected into the beer *en route* to the receiving tank where the gas escapes to provide the blanket of carbon dioxide above the beer now in the receiving tank. As the tank fills the air within it is displaced upwards and does not come into contact with the beer. Alternatively the receiving tank can be filled with deaerated liquor (containing $< 10 \mu\text{g/l}$ oxygen), which is displaced by top pressure of carbon dioxide. When the tank receives the beer the carbon dioxide can be recovered into a gas balloon (Section 15.4).

Using these techniques dissolved oxygen levels in beers after filtration into bright beer tanks can be as low as $50 \mu\text{g/l}$, with little deleterious effect on flavour and haze stability.

15.2.4 Flavour, aroma and colour adjustments by addition

Maturation of beer is a process in which flavour change takes place over a period of time under the influence of yeast. This yields positive improvements in flavour as unpleasant flavour volatiles are reduced in concentration. The flavour, aroma and colour of beer can also be changed by adding specific compounds, normally after primary fermentation, so that changes can be effected during maturation of the beer and before filtration. Some of these compounds will require time over which to produce maximum effect and so will be in contact with the beer throughout the maturation or conditioning process. Some treatments can be made much later and applied to the beer at the time of filtration. Beers can also be blended together and recovered beer can be added to the fresh beer stream, although it is clear that these operations must be performed with great care to ensure that the quality of the main beer stream is not adversely affected.

The brewing plant required to carry out these changes effectively and reproducibly needs careful design and is frequently expensive. However, it provides the chance to make flavour changes post-fermentation, which means that a number of different beers may be derived from one wort stream, which can be highly cost effective for plant utilization. This technique, whilst very skilfully practised by some brewers, particularly in the UK, is scorned by others as indicative of an approach to brewing driven by cost cutting rather than a desire to produce individually crafted beers. The approach has been called by dissenters ‘badge engineering’.

Colour

It is difficult to accurately control colour to the required specification from brewhouse treatments alone. This is a result of inherent variations in the colour of the malts and inconsistencies in colour formation in wort boiling. It is therefore common practice in many countries to brew the beer to a colour slightly below the required specification and then to increase the colour after fermentation. The most frequently used substance for this is caramel. Caramel syrups are made by heating sucrose solutions or starch syrup solutions containing a high level of glucose to 150°C (300°F) under pressure. The yield is improved by the addition of ammonia as a catalyst (see also Chapter 2 and Chapter 9).

Caramels used in brewing are electropositive and can have a colour of 50,000 °EBC and contain 65% solids. In Europe, caramels are classified and those used in brewing are designated E150c caramels. These caramels can contain 4-methyl imidazole which is toxic to rabbits, mice and chickens (Hasimoto, 1973) and more recent research has revealed the presence of 2-acetyl-4-tetrahydroxybutyl imidazole (THAI), which has been found to react as a anti-pyridoxine factor in rats leading to lympholeucocytopaenia (Leach, 1989). For these reasons caramels used in brewing must have THAI levels < 10 mg/kg and 4-methyl imidazole levels < 1 mg/kg. Caramels are allowed to be added at *quantum satis* levels (a level capable of achieving the desired technological effect whilst observing good manufacturing practice) (Long, 1995). Caramels can be supplied in containers holding from 10 to 500 kg of material and the caramel is often added to the beer by pumping directly from the supplied container, which is usually returnable. As an alternative to caramel, liquid extracts from roasted malts can be used but these are much more expensive and their use seems likely to be minimal unless further legislation restricts the use of caramel (Chapter 2).

Flavour

The most frequently made flavour changes are to alter the bitterness of the beer by the use of a post-fermentation addition of isomerized hop extract or to increase sweetness by the use of sugar solutions called primings. Again, it is very difficult to control the bitterness of beer solely from hop addition in the wort kettle. Isomerization rates in the kettle vary in relation to wort composition (Chapter 8). Brewers vary in their approaches to the use of post-fermentation bittering. Some brewers recognize the variability of wort boiling and plan to derive, say, 90% of bitterness from the kettle with the remainder being added after fermentation. Other brewers will not use post-fermentation treatment and will strive to achieve desired bitterness levels from wort boiling alone. At the other extreme at least one major brewer derives bitterness almost 100% by addition after fermentation.

Isomerized extract (Chapter 8) is usually added before filtration and utilization levels of at least 70% are possible (Gardner, 1993). Packaging of beer in clear or green glass bottles is discussed in Chapter 21. Protection of this beer against sun-struck flavour can be achieved by adding reduced isohumulones such as tetrahydro-iso- α acid as an alternative to isohumulone at this stage of the process. The reduced isohumulone does not react under the influence of light to give rise to the thiol, 3-methyl-2-butene-1-thiol, which is the material having the sun-struck flavour. Light stability is achieved only in the total absence of iso- α acid and this must not therefore be carried over by the yeast. This can be difficult to achieve in practice and has limited the complete effectiveness of these preparations.

Sugar solutions (primings) can be added to beers. This can encourage secondary fermentation but also provide a residual sweetness to the beer that is an important characteristic of mild beers in the UK. Primings can be solutions of sucrose or 'invert' mixtures of glucose and fructose. A typical strength would be 34 °P (8.5 °Sacch) and the addition rates are usually in the range 0.3 to 1.75 l/hl of beer.

Aroma

Brewers frequently make a late addition of aroma hops to the kettle close to the end of boiling (Chapter 10). The objective is to impart hop character to the beer derived from the essential oils. This late hopping process is difficult to control and inherently variable as the oil content of hops varies widely within a variety from year to year. There have been attempts, therefore, to derive oil preparations from hops, which can be added after

fermentation and so change the aroma of beer. Some of these preparations contain resins as well as oils and are known as oil-rich extracts. They must be added to beer before filtration to avoid the possibility of haze developing in the beer during storage.

Recently (Marriott, 1999) there have been further developments to produce aroma products that are completely soluble in bright beer (see also Chapters 7 and 8). These can give potentially 100% utilization and so a completely reproducible effect on aroma. Essences have been produced that can reproduce the effect of late copper hopping and even the dry hopping of cask ale (Chapter 7). Essentially the insoluble hydrocarbon fraction of the oil must be removed to produce a sesquiterpeneless oil. This oil can then be further fractionated to produce individual products with 'spicy' or 'floral' characters. These essences can be added to bright beer at rates of 50 to 100 $\mu\text{g/l}$ and have profound effects on aroma and flavour. They are normally supplied as 1% solutions in ethanol.

Blending

Beers can be blended post fermentation and this yields more uniform products and provides further opportunities to deliver a volume of beer to its final specification. Recovered beer can also be added post fermentation but this is a technique requiring considerable care, often demanding excessive pasteurization of the beer with a consequent adverse effect on flavour. For this reason recovered beer is best added before fermentation, e.g., to the whirlpool (Section 15.5).

Sulphur dioxide

Sulphur dioxide is both a natural product of fermentation (Chapter 12) and can be added to beer after fermentation. It provides a measure of protection against flavour deterioration by oxidation and has bacteriostatic properties. Maximum levels of sulphur dioxide in beer are usually governed by statute and vary in different countries. In the European Union the maximum permitted level is 20 mg/l (as SO_2), except for cask conditioned beer when the level is 50 mg/l. Sulphur dioxide is usually added as sodium or potassium metabisulphite and can so be added along with finings or priming sugar.

Water

It is an accepted strategy in many breweries to brew at a higher gravity than that at which the beer is subsequently sold (Chapter 6). Many studies have been made on the effect of gravity (wort strength) on the properties of the resultant beer and the physiological health of the yeast after subsequent generations at high gravity (> 1060 or 15°P) (Pfisterer and Stewart, 1975; Stewart *et al.*, 1999). Dilution of the fermented high gravity beer is best effected after beer filtration and the quality of the diluting water used is of the utmost importance (Chapter 3). This needs to be of brewing quality because this water is to be drunk by the consumer of the product. It must be free from taint, sterile and deaerated. This is normally achieved by treating the water by passing it through a purpose-built plant involving a trap filter to remove solids, a carbon filter to remove chlorine residues and inert gas stripping or vacuum stripping to remove oxygen. Sterilization is often effected by the use of uv light or by filtration through a sterilizing sheet filter ($0.45 \mu\text{m}$). The oxygen level in the water should be $< 50 \mu\text{g/l}$.

Accurate and precise addition of the deaerated water to the beer is essential. Errors at this stage of addition are serious, too much dilution will prejudice beer quality and could make the batch of beer unsuitable for sale, too little dilution would result in a high alcohol content and consequent tax (duty) problems. Sophisticated dilution machines under microprocessor control are now available, in which water is blended to

the beer stream following accurate measurement of density often by the oscillating U-tube method.

15.2.5 Maturation vessels

Vessels for the maturation of ales or lagers are normally cylindrical in shape. They are similar to fermentation vessels (Chapter 14). They can be horizontal or vertical in aspect. Tanks can be made of stainless steel, mild steel with a glass, enamel or plastic epoxy lining, or more rarely of aluminium. Horizontal tanks are usually of 100 to 500 hl (60–300 imp. brl) capacity, but the vertical cylindroconical tanks can be up to 6,500 hl (4,000 imp. brl). Horizontal tanks are frequently built inside the brewery in warm or cold conditioning rooms. Vertical tanks are externally clad and usually stand in the open. Tanks are normally fitted with impellers for mixing and with a temperature control system. Temperature is usually controlled by a cooling jacket supplied with brine, ethanol as industrial methylated spirit (IMS), or propylene glycol. Ethylene glycol has been used but it is highly toxic. Older designs incorporated internal cooling coils supplied with chilled water or IMS. Frequent inspection of the integrity of the coils is essential if a coolant other than water is used, as small leaks would be disastrous for beer quality.

The escape of carbon dioxide gas is limited by closing the vessel and hence pressure regulation is required. Devices are used to control gas pressure up to 1.4 bar (20 lb./in.²). Water column or mercury column manometers were once used but now weight loaded valves are employed, which can be set to open and release pressure at a defined level (Fig. 14.3).

Materials of construction and vessel size

Construction is similar to that of fermenting vessels (Section 14.3.2). The preferred metal of construction would now be type AISI 304 stainless steel, it is rare that conditions are such that the much more expensive AISI 316 is needed. The inner surface of the tank should be as smooth as possible so as to provide no surface indentations for the lodging of soil (Section 14.3.2).

Size is important when the vessels are to be used for fermentation and maturation, i.e., uni-tanks (Fig. 15.1). This relates to the hydrostatic pressure on the yeast during fermentation and a generally acceptable height for a fermenter is now not greater than 15 m (about 50 ft.). In a purpose-built maturation tank there is no such restriction and tanks up to 30 m (almost 100 ft.) and even 40 m (130 ft.) in height have been built. Size usually relates to brewery throughput and brew lengths. A rule of thumb is that the size should be equivalent to a half-day production, larger tanks take too long to fill and will contain beers of variable age and hence potentially variable final flavour. Tank diameters are usually 3.50–4.75 m (11.5 to 16 ft.) and the cone angle is 60° to 75°. The ratio of diameter to beer height in the cylinder can vary from 1:1 to 1:5. The volume of the headspace in the tank relates to the work to be done. A vessel used solely for cold maturation will require a headspace volume of 5% of the total, whereas if diacetyl removal in the warm is included the volume excess should be 10%. A fully equipped fermenting vessel will need 25% headspace.

Cooling

The details of temperature control in fermentation were discussed in Chapter 14 and many of the principles apply to the maturation vessel. Chilled water is unsuitable for use as a coolant below 2°C. Propylene glycol has the disadvantage of being extremely

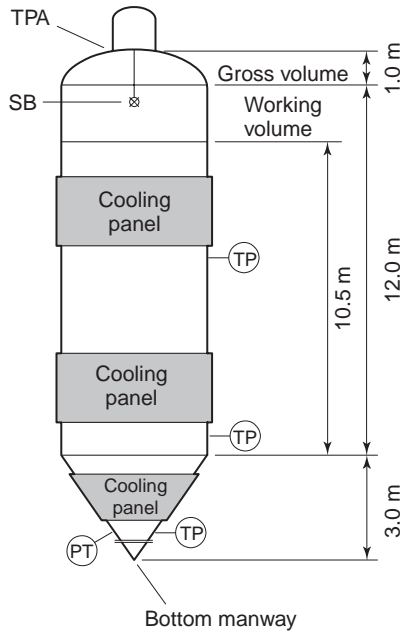

Fig. 15.1 Schematic representation of dual-purpose fermenting vessel (1600 hl, 1000 imp. brl); TP, temperature probes; PT, pressure transducer; TPA, top plate assembly containing a pressure relief valve (0.8 bar, 12 lb./in.²), anti-vacuum valve (55 mm WG), CO₂/CIP combination valve, top pressure transmitter, access hatch, inspection light, trace heating and cabin for weather protection; SB, spray ball operating at 5 bar (74 lb./in.²), 80 °C (175 °F), 17 m³/h; Cooling panels contain coolant at 4.5 bar (66 lb./in.²); Height 16.0 m; Diameter 4.25 m; Working temperature, -1 to 90 °C (30–190 °F); Working pressure, 0.7 bar (10 lb./in.²); Wort depth 13.5 m; Weight empty 14 t; Weight full 212 t; Gross volume 1922 hl; Working volume, 1640 hl; Freeboard volume 282 hl (17% of working volume); Cone volume 147 hl (9% of working volume; included cone angle 70°) (Barnes, 2001).

viscous (13.4 mPa at 0 °C). Ethanol (IMS) is often the preferred coolant, but it should be noted that both IMS and propylene glycol will oxidize slowly to acid products which will attack mild steel pipework and cause sludge deposits. Exposure to air should therefore be minimized and hence solution strengths should be maintained (30% for ethanol and 40% for propylene glycol). Sometimes a corrosion inhibitor is included with the secondary coolant. There has been renewed interest in direct expansion systems using a primary refrigerant such as ammonia. Ammonia has no ozone depleting effect and therefore has this major advantage over the fluorinated hydrocarbons, which are now being withdrawn as refrigerants. However ammonia is a very corrosive, dangerous and pungent gas and brewers still tend to favour indirect systems (Section 14.3.3).

Several designs of cooling jacket are available (Chapter 14). The requirements are more simple than in the fermenter or combined vessel and the choice often depends on the manufacturer's capability. Coils can be wound onto the vessel section and seam welded (limpet coils). An alternative uses a profile plate, which is preformed and spot-welded on to the vessel, a variation of the preformed plate is the 'dimple jacket', which is also preformed, and spot welded (Fig. 15.2). An inflated 'quilted jacket' is a further alternative most frequently used in direct expansion systems with ammonia. Most vessels will have two cooling sections on the cylinder of the vessel and a dimple jacket on the cone. The cone section cooler will usually be used at the end of primary fermentation to aid yeast flocculation.

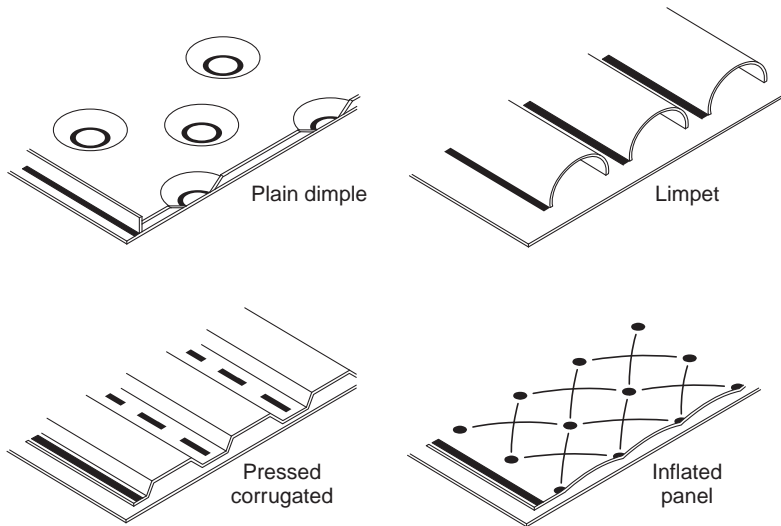

Fig. 15.2 Designs of cooling jackets for dual-purpose fermenting vessels: plain jacket, not usually used because it requires thick vessel construction to resist external pressures; limpet, provides a flow-path for coolant, but again relatively heavy; pressed corrugated, lighter construction than limpet and widely used for secondary refrigerant systems; inflated panel, low volume and suited to primary refrigerant systems acting as an evaporator (Barnes, 2001).

Refrigeration load in a brewery is a considerable fixed cost and therefore the design of the control system to ensure the most efficient use of energy is important. The number of pumps for secondary coolant should be minimized in the design. A variable speed drive in the secondary coolant system will maintain a constant pressure differential in the supply and will help to minimize losses. There should also be the facility to shut down the system if no vessels require cooling. The position of the temperature sensor is critical to efficient cooling. The sensor should be positioned at between one-third and one-half of the vessel height from the bottom and should protrude about 500 mm (20 in.) into the tank to avoid any temperature effect from the internal surface of the tank. Information from the sensor in a modern brewery will be fed back to a computer at which the desired temperature regimes may be set.

Cleaning-in-place (CIP)

Cylindroconical maturation vessels are cleaned by CIP systems. The principle of this cleaning is very similar to that described for fermenting vessels (Section 14.3.3) and discussed in overall detail in Chapter 17. Maturation vessels do not generally have such a high organic soil level (yeast deposits) as fermenting vessels and therefore respond to cleaning with acids, which is usually cheaper than caustic alkali based systems using a sequesterant. However, as with fermenters to save costs of detergent, the bulk of the soil should be removed with jets of water in an impact system. The jets used vary enormously in design but are often similar to those used for cleaning fermenting vessels, where the nozzles on the head rotate in one plane whilst the head itself rotates at right-angles on the support pipe (Fig. 14.6). The basic sequence of CIP is similar to that used for fermenters (Section 14.3.3) with slightly shorter time sequences.

Insulation

Similar principles apply to those discussed in Chapter 14 in relation to fermenting vessels. Horizontal tanks are usually contained within a room in the brewery which is

temperature controlled. The tanks themselves are not insulated. Vertical tanks require insulation. Insulation materials often contain chloride ions and a chloride barrier is needed against the stainless steel of the vessel to prevent attack of the surface by chloride (Section 14.3.2).

15.3 Stabilization against non-biological haze

Competition between brewers is intense and the quality and consistency of their beers is paramount. This demands that the beers following maturation should not only have desirable, stable flavours but must also display stability with respect to haze, i.e., the beers must be bright and remain so during the period from dispatch from the brewery to drinking. Therefore, in addition to removing yeast, beers must have the precursor constituents of haze removed to ensure long-term stability. Beer haze and its chemistry are considered in Chapter 19. In this Chapter we focus on the removal of haze-forming materials to ensure the production of a stable beer.

A range of substances can cause non-biological haze in beer:

- β -glucans, which can often lead to hazes not easily seen by eye but which cause high levels of light scattering in 90° haze meters
- α -glucans (starch), which can behave similarly to β -glucans
- pentosans, which may be derived from wheat based adjuncts
- dead bacteria from malt
- oxalate from calcium deficient worts.

However, the most common, important and troublesome type of non-biological haze is that deriving from the cross-linking of proteins and polyphenols and it is the elimination of the precursors of these polymers to which beer stabilization treatments are directed.

The most effective beer treatment with respect to haze stability is the cold storage of the beer for about seven days at -1 to -2 °C (30 – 28 °F). This technique allows a reduction in the cost of other beer treatments designed to remove potential haze-forming proteins and polyphenols. However, brewers frequently wish to accelerate the process of haze stabilization and achieve greater stability than is possible with cold storage alone.

15.3.1 Mechanisms for haze formation

Colloidal haze in beer arises from the formation of protein-polyphenol complexes during beer storage (Gopal and Rehmanji, 2000, and Chapter 19). Fresh beer contains acidic proteins and numerous polyphenols. These can come together by loose hydrogen bonding but the associations formed are too small to be seen by the naked eye. These polyphenols, called flavanoids, can further polymerize and oxidize to produce condensed polyphenols, which have been called tannoids (Chapon, 1994). These tannoids can ‘bridge’ by hydrogen bonding across a number of proteins to form a reversible chill haze (Fig. 15.3). This haze forms at around 0 °C (32 °F) but redissolves when the beer is warmed to 15 °C (59 °F). After further storage of the beer strong bonds can form between the tannoids and proteins and irreversible, permanent haze is formed. The rate at which this haze is formed and its extent of formation depends on the raw materials used in wort preparation and the process conditions. This ‘model’ suggests that effective stabilization should be achieved by removing from the beer the constituents of the haze, i.e., the ‘tannin sensitive’ proteins and/or the polyphenols.

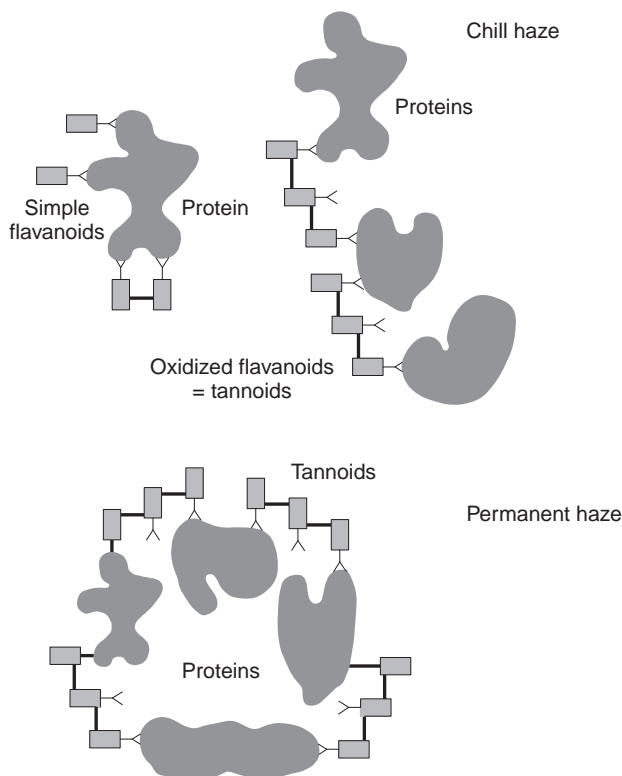

Fig. 15.3 Models of chill and permanent hazes development in beer (Gopal and Rehmanji, 2000).

An alternative model of haze-formation has been proposed (Siebert *et al.*, 1996 and Chapter 19). This suggests there are a fixed number of binding sites on haze-forming proteins (proline residues) and that haze-forming polyphenols have two binding sites, through which they can jointly bind two adjacent protein molecules. If there is an excess of protein over polyphenol then the polyphenol is involved in binding just two protein molecules together and these dimers do not constitute insoluble complexes. If the amount of polyphenol greatly exceeds that of protein then there is a shortage of protein binding sites and again haze complexes will not be formed. Hazes are therefore formed when there are equivalent amounts of protein and polyphenol in the beer. This model suggests an alternative strategy for the prevention of haze, i.e., substantially increase the amount of either protein or polyphenol. This is not a favoured approach and most brewers will seek to reduce levels of either the proteins or polyphenols or most likely both.

15.3.2 Removal of protein

All of the haze-forming protein in beer comes from malt. Proteins which are particularly liable to cause haze are rich in proline and have molecular weights $>10,000$. A concentration of 2 mg/l will give a haze value in beer of >1.0 EBC formazin units (Chapter 19) which will give a perceptible turbidity to the beer. However, other proteins can also form haze and some of these have good foam potential. It is not, therefore, a simple matter to categorize the proteins responsible for haze-formation in beer. It can

simply be concluded that the presence of hydrophobic groups on the surface of protein tertiary structure increases the capacity to form haze and the capacity to improve foam.

Lowering the overall protein concentration will increase haze shelf-life. The use of low nitrogen malts (TN < 1.65%) and/or diluting the grist with nitrogen-free adjunct is recommended. It is difficult to make a recommendation with respect to the extent of proteolysis in malting or mashing because whilst increased proteolysis will reduce molecular size it will lead to increased numbers of polypeptides some of which will have haze-forming potential. Certainly malts with high soluble nitrogen ratios (> 40%) have inherently poor foam potential. It is thus the removal of protein that is important. Proteins can essentially be removed by hydrolysis; usually by enzymes, by precipitation or by adsorption.

Hydrolysis

The usual enzyme to use is papain derived from papaya fruit although bromelain from pineapple and an acidic protease from *Bacillus subtilis* have been used (Chapter 2). The optimum dose is $5\text{--}15 \times 10^6$ units/hl (1 unit is the amount of enzyme generating $1 \mu\text{g}$ soluble tyrosine/hour under rigidly standardized test conditions). This usually translates to 0.5–4.0 g/hl depending on the formulation. The enzyme needs a contact time and is usually added to the beer during maturation. Some preparations can be added to final beer but they must be sterile and totally soluble. This treatment is cheap but is risky. Proteolytic enzymes will damage beer foam proteins and some can survive pasteurization so will continue to have an effect on foam during beer storage. There can also be an adverse effect on flavour stability by the liberation of free thiol groups from peptides in the beer.

Precipitation

Since proteins form haze complexes with polyphenols it is not surprising that a class of polyphenol can be used for the removal of haze sensitive protein. Thus anionic tannic acid reacts with cationic proteins to form an insoluble complex. This is as a result of interaction between ketone groups on the tannin and nucleophilic groups (SH, NH₂) on the protein. The most effective tannins are known as gallotannins extracted from gall nuts or from the sumach tree. The tannin preparation would normally be added *en route* to maturation at 0 °C (32 °F) at 5–9 g/hl and would require at least 24 hours contact time for full effectiveness. Essentially the tannins act as a precipitant of the tannin sensitive proteins (Anderson *et al.*, 2000) and when used in this way in the cold tank a large volume of ‘tank bottoms’ is formed. This requires careful movement of the beer from above the sediment or the use of a centrifuge or filter to separate beer from the tank bottoms (Section 15.5). If this is not done losses of beer will be high. For this reason the use of tannic acid for protein removal has generally gone out of favour in recent years. However, improved preparations of gallotannins have become available (Musche and de Pauwe, 1999). These high molecular weight gallotannins can be dosed into the beer before filtration into the inlet buffer tank to the filter at 0 °C (32 °F) at rates of 2–4 g/hl. A contact time of 5–25 minutes is claimed to be sufficient. This method of treatment avoids the production of tank bottoms but is limited by the relatively short filtration run achieved and for this reason centrifugation is still often used before the filter. Gallotannins have the added property of removing metals from beer (Musche and de Pauwe, 1999). Iron, aluminium, lead and copper can all be removed by gallotannin treatment and filtration. The metals can be lowered in concentration to below the levels at which the properties of beer are harmed.

Adsorption

Silica gels are used as protein adsorbents. They are produced for brewers in two main commercial forms: hydrogel (> 30% water) and xerogel (< 10% water). To produce a

silica gel, sulphuric acid and sodium silicate solution are mixed under controlled conditions to produce a 'hydrosol' of colloidal polysilicic acid. These colloidal species can be condensed to produce a hydrogel in which the water phase is immobilized in the silica matrix (McKeown and Earl, 2000). The hydrogel can then be further processed and then milled to produce a material of defined particle and pore size and surface area. Optimum pore size is in the range 30–120 μm diameter with a surface area of around 800 m^2/g .

Alternatively, the hydrogel can be dried before milling to produce a xerogel where the surface area can range from 300–800 m^2/g with again pore sizes in the range 30–120 μm . Protein adsorption takes place on so-called silanol (SiOH) sites on the silica gel and adsorption capacity is a function of the number of these sites. Generally, though, the number of sites exceeds the quantity of available protein.

Silica gels can be added to beer in maturation but their most attractive characteristic is their usefulness when dosed into the beer stream prior to filtration. Adsorption is therefore achieved with a very short contact time (80% of the adsorption is achieved in < 3 min.) between the silica and the beer. This also provides the opportunity to treat only a proportion of the beer in a maturation vessel, i.e., that proportion destined for a long shelf-life (> 40 weeks). In this situation the filtration quality of the gel is as important as its adsorbent property. The best filterability is obtained with large size gel particles but these are not so good for protein adsorption. Generally, hydrogels are good adsorbents but because of small particle diameter (< 10 μm) are relatively poor filter aids. Xerogels have larger diameter gel particles (up to 100 μm) and so are less good at adsorption than hydrogels but have superior filtration characteristics. Rates of addition are normally between 50 and 80 g/hl. Brewers have to make a choice of which material to use depending on their circumstances. It is claimed (McKeown and Earl, 2000) that it is now possible to manufacture small particle sized xerogels that will deliver high filtration rates as well as displaying the optimum adsorption characteristics of a small sized hydrogel (< 10 μm).

Beer proteins are associated with the good foaming potential of beer. There has therefore been concern over the effects of silica gels on foam and head retention. The amino acid sequence of the protein determines its hydrophilic/hydrophobic balance. It is generally accepted that hydrophilic proteins are haze-formers and hydrophobic proteins promote foam.

The selectivity of different silica gel preparations for removing haze-forming proteins has been studied in both all-malt and high adjunct (maize) beers (Guzman *et al.*, 1999). Total protein adsorption was influenced by beer type but adsorption of haze-forming protein was not. Further, it was possible to manufacture a xerogel which showed selectivity for haze-forming, hydrophilic proteins. Maximum uptake appeared to occur around 100 μm pore diameter.

An essentially different method of using the adsorptive properties of silica derivatives to remove protein is to use the compound in the form of the liquid silica hydrosol, the intermediate in the manufacture of the hydrogel or the xerogel (Green *et al.*, 2000). The hydrosol is a bluish opalescent liquid with a specific area of 300 m^2/g in relation to its SiO_2 content. Essentially, if added to beer the hydrosol forms a gel by cross-linking the SiO_2 particles. The gel flocculates and sediments and so adsorbs protein, which settles out as tank bottoms. The silica sol can be added to the beer in the maturation tank. Careful mixing is required and considerable tank bottoms are produced which must be drawn off before filtration or removal by centrifugation. The sol can also be added with the body feed to the filter when it is effective in lowering haze but will not contribute to

filtration performance like the gel. Further development work on silica sol and gel structure in relation to the removal of hydrophilic haze-forming protein from beer seems likely to be worthwhile. This technique remains very useful and has wide acceptance by brewers.

15.3.3 Removal of polyphenols

There is still some concern from brewers that techniques relying solely on the removal of protein for haze stabilization will affect beer foam. Techniques to remove polyphenols from beer have also been developed. The polyphenols responsible for haze-formation by interacting with proteins derive from malt with a small contribution from hops. Thus the possibility exists of eliminating polyphenols from beer by eliminating them from malt. Two basic methods of polyphenol removal have therefore been practised; use of polyphenol-free malt and the much more widespread adsorption technique applied to wort or beer.

Adsorption

Early work involved the use of synthetic materials such as 'Nylon 66', which were effective polyphenol adsorbents. Further work saw the development of the polymer PVPP (polyvinylpyrrolidone). This is a cross-linked polymer, which is insoluble in water, alcohol and acid (Gopal and Rehmanji, 2000) and hence has a high surface area for adsorption of haze-forming polyphenols. This occurs at the surface of the material by strong hydrogen bonding. It is proposed that the structure of the synthetic polymer limits internal bonding thus maximizing the number of external sites and reducing the concentration of PVPP needed for effective stabilization.

PVPP can be employed as a 'single use agent' and in this situation the insoluble PVPP-polyphenol complex is removed on the filter with kieselguhr depth filtration. PVPP for single use is ground to a fine powder with a large surface area to weight ratio and is used at rates of 15–25 g/hl. The PVPP can be added to the beer stream along with kieselguhr at 0 °C (32 °F) and, like silica gel, a short contact time is effective, although in this case about ten minutes is needed from the point of contact with the beer to removal on the filter. Some brewers prefer to add single use PVPP to the maturation tank. This is usually at rates of 10–15 g/hl and a large dense grade of powder is used that promotes sedimentation. A thorough mixing of the tank contents by pumped recirculation is needed for optimum effectiveness. The bulk of the PVPP-polyphenol complex is removed from the base of the tank after sedimentation, with final removal of suspended matter on the filter.

PVPP can also be used as a regenerable product. Washing with hot caustic soda solution breaks the PVPP-polyphenol bonds. Addition rate is normally 30–50 g/hl. The powder is of larger particle size and has greater mechanical strength than that for single use. The usual technique is to use the regenerable PVPP in a horizontal leaf filter or a candle filter (Section 15.5). A pre-coat of PVPP of 1–2 mm (0.04–0.08 in.) depth is layered onto the screens in the filter and PVPP is dosed into the beer stream by a proportioning pump. A rate of 10 hl/m²/h can be achieved and the precise rate is matched to that of the kieselguhr filter which follows. The treatment run will end when PVPP has filled the space between the screens of the filter. Spent PVPP is regenerated by circulating a solution of 1–2% sodium hydroxide at 60–80 °C (140–175 °F) through the PVPP filter bed for 15–30 minutes. The filter cake is then flushed with water at 80 °C (175 °F) to lower the pH value.

This is normally followed by a rinse with dilute acid, usually phosphoric (1% w/w) or nitric (0.3% w/w), until the pH value of the solution leaving the filter is about 4.0. This treatment removes carbohydrates and calcium salts trapped in the debris of the filter aid. The filter is then washed with cold water to achieve a neutral effluent. Finally water and carbon dioxide gas are used to displace the regenerated PVPP to the dosing tank. This can be assisted by spinning the screens in the filter to provide a centripetal force. Process losses are about 1% and these are made up by adding more PVPP to the dosing tank before repeating the cycle of treatment. There is greater capital cost in the use of redeemable PVPP but, for breweries with large outputs of beer requiring stabilization for long shelf-life (> 40 weeks), this is a cheaper option than single-use PVPP.

Generally, it has been accepted that the most effective stabilization occurs, whether with PVPP or silica gel when combined with the use of temperatures of 0 to -2°C (32–28°F) and at times in excess of 48 hours. However, recent work suggests that PVPP can deliver stabilization at 4°C (39°F) which is equivalent to that obtained at 0°C when assessed by shelf-life measurement (Byrne *et al.*, 1999). This could be of considerable significance in energy saving.

Proanthocyanidin free malt

Polyphenols in beer in the main derive from malt. The most reactive of the polyphenols are proanthocyanidins or anthocyanogens and are found in the barley testa. It would therefore seem feasible that if malt could be produced from a barley free of anthocyanogens then haze stability might be achieved without the intensive post-fermentation treatments described above.

Barley breeding work was carried out in the Carlsberg laboratories in the early 1970s with the objective of inducing mutations in barley so that anthocyanogen producing genes were ineffective (Jende-Strid, 1997). It should be noted that the resulting barleys were not produced by genetic transformation by the transplanting of genes from one species to another. The induced mutations were transmitted to commercial cultivars by classical techniques of crossing and re-selection. In the last 30 years over 700 mutants of winter and spring barleys have been produced (Sole, 2000). The problem has been the commercial acceptability of the varieties from both an agronomic and malting and brewing standpoint. Some varieties showed no dormancy and so lodged and effectively malted in the field and so were useless for commercial malting. There was no doubt however that beers could be brewed from anthocyanogen-free malts, which had haze shelf-lives equivalent to those beers stabilized with PVPP and/or silica gel.

The latest varieties to be trialled are Caminant, Chamant and Prominant in mainland Europe and Clarity in the UK. There has been relatively little interest in other parts of the world. Clarity appears to have sound agronomic properties and has been grown successfully on the light lands of eastern England. Clarity malt has been trialled in pilot breweries at Brewing Research International in the UK and at commercial breweries. Advantages have been demonstrated over conventional malts in lower polyphenol levels in wort and in haze shelf-life tests (Sole, 2000) and in the opportunity to use higher temperatures for stabilization ($+4^{\circ}\text{C}$ compared to -1°C). The problem has been in lower extract yield in the brewhouse, which has often been at least 1%, and this has limited acceptability of Clarity malt for some brewers. This has been counteracted in some situations by using Clarity malt as a proportion of the grist (say 50%).

Full acceptance of the use of anthocyanogen-free malts as an effective means of stabilizing beer awaits the demonstration of the economics of the whole system in relation to the costs of PVPP treatment.

15.3.4 Combined treatments to remove protein and polyphenols

Refined silica gel treatments are very effective at selectively removing haze-forming protein and PVPP will effectively remove the haze-forming polyphenols from beer. However, there is still some risk that foam potential can be reduced by excessive removal of protein and there is a belief that polyphenols contribute anti-oxidant properties to beer and give improved texture to beer in the mouth. These considerations have been used as reasons to favour a stabilization approach dependent on the removal of defined amounts of both protein and polyphenol. PVPP can be used with papain (Esnault, 1995) and is added with the enzyme. The dangers of excessive proteolysis with papain remain. PVPP cannot be added with gallotannins as it complexes immediately and will not adsorb the polyphenols in the beer. It can be added after gallotannin treatment (Musche and de Pauwe, 1999) when it will adsorb polyphenols and will complex residual tannic acid that can contribute a harsh astringency to the beer.

The most effective combined treatments have seen PVPP used along with silica gel added from separate dosing vessels (McMurrough *et al.*, 1999). Combined stabilization was shown to be more cost effective than the intensive treatments needed when PVPP or silica gel are used alone. Recently a combined PVPP/silica xerogel (3:7) preparation has been described (Gopal *et al.*, 1999) that works to reduce proteins and polyphenols in a single addition at 80 g/hl. This treatment is used without PVPP regeneration and achieves stabilization at lower dose rates than the treatments used alone which required silica gel at 95 g/hl and PVPP at 20 g/hl. Filtration characteristics on the kieselguhr filter were also excellent and better than hydrogels used alone.

The relative costs of treatments to remove protein and polyphenols from beer vary over time. Systems dependent on single use PVPP have high revenue costs. But if small volumes are being treated then the capital cost of recovery systems is avoided. Silica xerogels were expensive but recent developments have seen prices falling. The most revenue cost effective treatment is probably gallotannin treatment combined with recoverable PVPP, but this will almost certainly require the use of a centrifuge to process tank bottoms and there is considerable capital cost in the recovery system. In the final assessment of which treatment to use, cost will be only one factor. Brewers will rely on their experience of the ways their beers behave to achieve the maximum stability required.

15.3.5 Hazes from other than protein or polyphenols

Haze in beer can sometimes be caused by carbohydrate or bacterial cell wall material or calcium oxalate. Attempts to remove these hazes at the maturation stage are usually failures. These hazes do not respond to stabilization treatments appropriate for proteins/polyphenols. Beer hazes derived from carbohydrates or oxalate certainly can be controlled or eliminated by attention to raw materials or the conditions of mashing. Sufficient calcium must be present in the wort to precipitate oxalate from the malt or other grist materials.

The achievement of optimum starch conversion depends on adequate amylase levels in the malt but more especially on the attainment of gelatinization temperatures in the mash. This should result in no problems with α -glucan hazes in beer. A low-temperature stand in the mash (< 50 °C, 122 °F) will possibly promote further breakdown of potentially troublesome polymeric β -glucan or the use of bacterial or fungal β -glucanase preparations may be advantageous (see Chapters 2 and 4). Hazes derived from bacterial cell walls originate from poorly prepared malt, which has developed gross bacterial

contamination during germination. This should be avoided with proper specification and dealing with reputable maltsters. All these aspects are discussed in other parts of this book.

15.4 Carbonation

Carbon dioxide is a very important constituent of beer. It imparts sparkle and ‘mouth feel’ and sharpness associated with its properties as an acid gas. The concentration of carbon dioxide in beer for sale is carefully controlled to ensure that consumers of the beer can drink a consistent product. Beers that lack carbon dioxide, particularly lager beers, are dull and lifeless and are said to lack condition and be flat. The carbon dioxide is the gas produced naturally in primary and secondary fermentation and that added to the beer by ‘carbonation’.

At the end of primary fermentation the concentration of carbon dioxide in beer can vary from about 2 g/l (1 vol/vol) in a shallow ale fermenting vessel up to 5 g/l (2.5 vol/vol) in a deep cylindroconical vessel. During secondary fermentation the level of carbon dioxide will increase. If a controlled secondary fermentation is not carried out then carbon dioxide will normally have to be added to the beer. Such is the control now demanded for the precise level of carbon dioxide in finished beer that the gas levels are frequently adjusted after primary and/or secondary fermentation. The amount of carbon dioxide that will dissolve in beer depends on temperature and pressure.

15.4.1 Carbon dioxide saturation

Enclosed fermenters and maturation vessels are fitted with automatic gas pressure regulators that can be set at a predetermined pressure. Assuming that the gas above the beer is pure carbon dioxide then the gas that will dissolve in the beer at equilibrium is shown in Fig. 15.4. It can be seen that at a given temperature and pressure a particular equilibrium condition will be reached. Increasing pressure will lead to a linear increase in the weight of carbon dioxide dissolving in the beer. An increase in temperature will give a non-linear decrease in the amount of gas dissolved (Fig. 15.5). These factors derive from Henry’s Law, which states that the concentration of gas in the liquid phase is equal to the imposed pressure on the gas divided by Henry’s constant that is temperature dependent. This is of fundamental importance in practical brewing and it must be remembered that as temperature rises substantially less carbon dioxide will dissolve in beer. It is therefore extremely important to keep beer as cold as is practicable after fermentation to keep carbon dioxide in solution and avoid the necessity for excessive artificial carbonation. It is normally the convention in brewing to state the concentration of carbon dioxide as volumes of gas at standard temperature and pressure per volume of beer. A gram molecule of a perfect gas occupies 22.4 litres at STP and so one volume of carbon dioxide is equivalent to 0.196% carbon dioxide by weight.

At constant temperature and pressure the amount of carbon dioxide dissolving in beer will be a function of the time of contact between beer and gas and will decrease exponentially as equilibrium is approached. Increasing the surface of the beer exposed to gas can increase the rate of dissolution and a very shallow layer of beer will approach saturation more quickly. Further, if bubbles are created then a very large surface area is presented for gas transfer into the surrounding beer. In deep tanks, hydrostatic pressure also affects the concentration of carbon dioxide in beer (about 0.5 vol. increase/metre

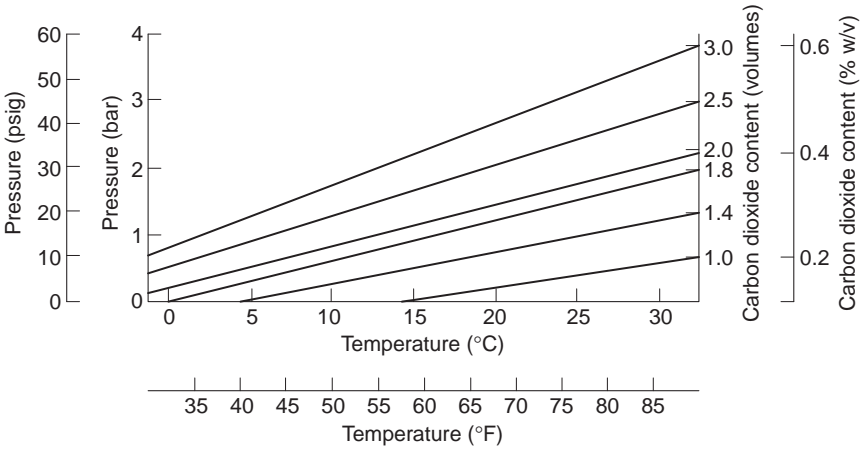

Fig. 15.4 Relationship between equilibrium values for dissolved carbon dioxide, temperature and pressure (Hough *et al.*, 1982).

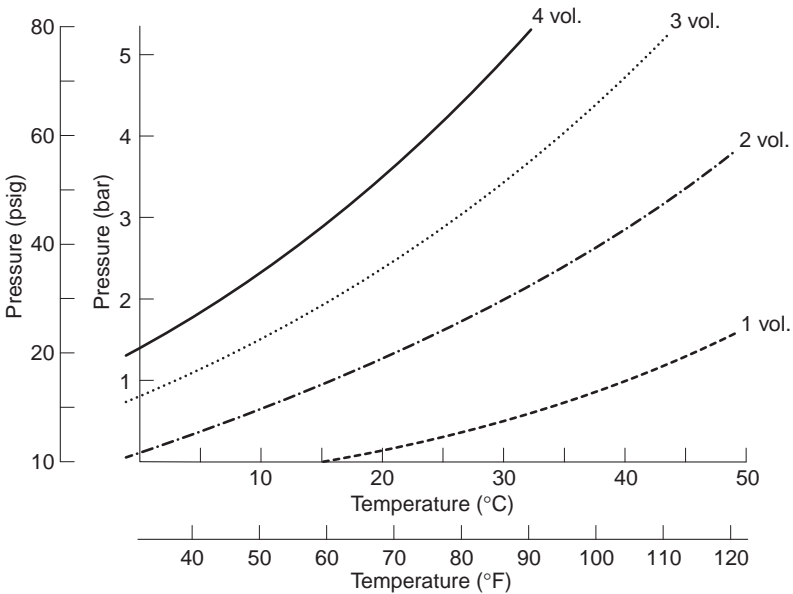

Fig. 15.5 Effect of temperature on pressure for fixed contents of carbon dioxide. Note that an increase in temperature gives a non-linear decrease in the amount of gas that dissolves, viz., say at 3 bar the equilibrium occurs for 4 vol. at 15°C, 3 vol. at 26°C and for 2 vol. at 41°C (Hough *et al.*, 1982).

depth) and the concentration at the base of the tank is higher than at the surface. Convection currents in the beer affect this gradation.

Beer is capable of holding carbon dioxide in a supersaturated state, so rapid release of pressure or increase in temperature does not immediately lead to attainment of the appropriate equilibrium. This is advantageous when serving highly carbonated beers (say 3 vol. CO₂) from bottles. When this beer is poured into a glass, the gas does not normally effervesce uncontrollably ('gushes') but releases carbon dioxide slowly. Knowledge of

Henry's Law thus provides the understanding for controlling the carbon dioxide content of the beer prior to filtration and subsequent packaging. For standard lager beers it is normal to aim for around 5 g/l (2.5 vol. or 0.5%) of carbon dioxide in the beer. The pressure release valve will normally be set to give a slightly higher carbon dioxide content to compensate for the subsequent losses in filtration and packaging.

Inevitably, some carbon dioxide produced during secondary fermentation will escape. This escaping gas is an important factor in beer maturation because it exerts a cleansing effect by purging volatile fermentation products and so accelerating the flavour improvement process.

15.4.2 Carbon dioxide addition

All processes after secondary fermentation should be designed to keep carbon dioxide in solution in the beer. Thus beer should be kept cold and under the appropriate pressure of carbon dioxide to prevent gas release. However, situations will arise when temperature will rise or pressure will fall and gas will escape. The carbon dioxide must then be replaced in the beer before packaging. This is frequently achieved after filtration during transit to the bright beer tanks.

This addition of carbon dioxide can occur whilst chilling beer through a plate heat exchanger (Fig. 15.6) and so can take advantage of the turbulence of the beer in creating good conditions for gaseous exchange. A purpose-designed carbonation unit (Fig. 15.7) can also be used. This consists of a long pipe usually in the form of U-tube bends through which the beer flows. Carbon dioxide is injected as fine bubbles and the uptake, even in this form, can take a considerable time. The carbon dioxide must be the purest form available and no oxygen must be introduced. The injection unit must be easy to clean and must be cleaned regularly. Carbon dioxide can also be added 'in-vessel' but this is frequently less efficient and more difficult to control. A 'carbonation stone' is sometimes used to ensure production of fine bubbles of carbon dioxide to aid dissolution in the beer. This technique is sometimes described as 'gas washing' and provides an opportunity for the removal of oxygen and unwanted flavour volatiles as well as carbonation. After 'washing' the vessel must be sealed to allow pressure build-up and the dissolution of carbon dioxide. There are a number of problems associated with externally added carbon dioxide and it is good practice to avoid this technique as far as possible.

Care must also be taken not to dissolve more carbon dioxide in the beer than the specification allows. Reducing carbon dioxide levels is difficult without creating froth or fob. This reduction can be achieved by gas washing with careful bubbling of oxygen-free

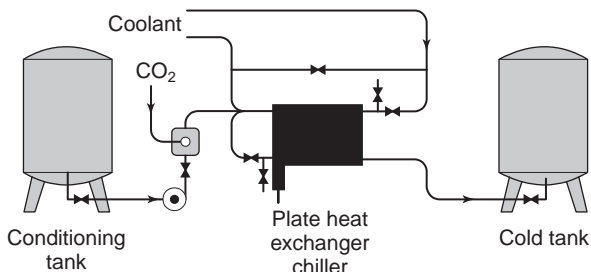

Fig. 15.6 Carbonation and chilling of beer 'on the run', from conditioning tank to cold tank (Hough *et al.*, 1982).

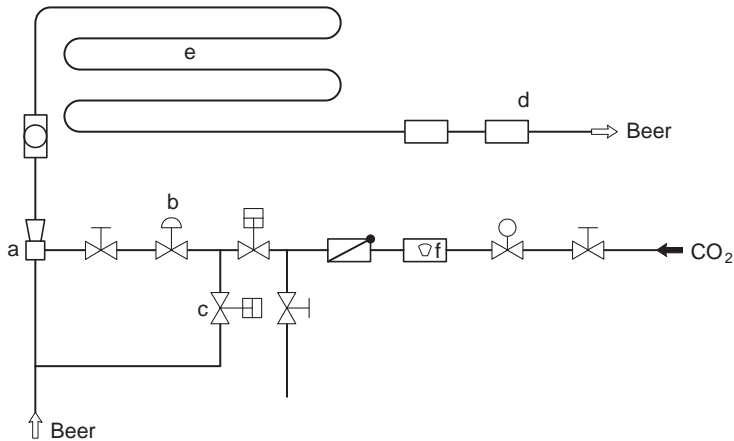

Fig. 15.7 Carbonation unit; (a) venturi nozzle, (b) carbon dioxide control valve, (c) CIP valve, (d) carbon dioxide sensor, (e) carbon dioxide dissolving area, (f) carbon dioxide measuring device (Kunze, 1999).

nitrogen gas through the beer. Nevertheless, this technique is often a source of reintroduction of oxygen to beer with adverse effects on haze and flavour stability and loss of foaming potential.

It must never be assumed that over carbonation of a beer reduces the uptake of oxygen if the beer is exposed to air. This uptake will be a function of the difference in partial pressures between the beer and the air in contact with it and is not influenced by the carbon dioxide content of the beer. Turbulence in movement should be avoided for beer which has been carbonated, either naturally or by external addition. Turbulence will lead to the loss or 'break-out' of carbon dioxide, the potential pick-up of oxygen and loss of foam potential because of protein denaturation at the gas/liquid interfaces.

15.4.3 Carbon dioxide recovery

The cost of carbon dioxide gas varies but it is generally expensive and certainly costs more than nitrogen. Before contemplating the economics of carbon dioxide recovery in a brewery the use of nitrogen gas as an alternative to carbon dioxide for ensuring anaerobic handling of beer should be maximized. On this basis the amount of carbon dioxide required in breweries varies considerably from about 1.3 to 2.0 kg of carbon dioxide/hl of beer produced. Of course carbon dioxide is essential for many purposes and there is the opportunity to collect the gas from enclosed vessels during fermentation. An essential aspect of recovery systems is that the gas must be purified if it is to be added to beer.

Carbon dioxide is normally collected through a fob tank into an inflatable balloon (Fig. 15.8), and from there it passes through water scrubbers and carbon purifiers before being compressed at the liquefying pressure of 18–22 bar (265 to 320 lb./in.²). This creates considerable heat and the compressed gas must then be cooled and so liquefied. The gas is dried through alumina driers and then stored as liquid until required for use when it can be restored to the gaseous state through an evaporator. Up to 2.0 kg of carbon dioxide per hl of beer can be recovered by this technique and this could represent the whole of a brewery requirement. However, recovery is often much less than this as a result of losses and cleaning of the gas. Many brewers expect recovery systems to provide around 60% of requirement.

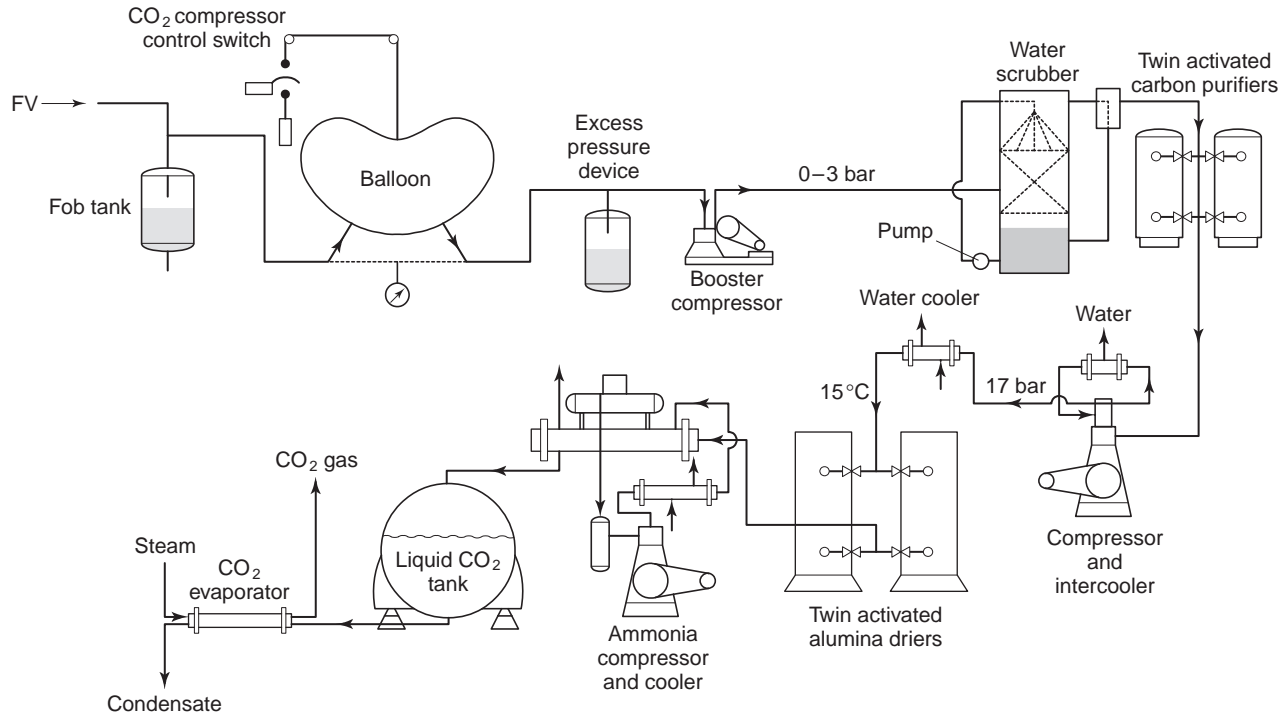

Fig. 15.8 Equipment for collecting, purifying, storing, and releasing carbon dioxide (Hough *et al.*, 1982).

15.5 Clarification and filtration

Clarification of beer involves the removal of yeast and the sedimented protein and polyphenol haze material derived from the beer stabilization techniques and cold break (Section 15.3). Beer flavour is considerably more stable when it contains suspended yeast as the yeast promotes strongly reducing conditions. Total removal of yeast should therefore be delayed to the last possible moment before packaging. In cask beer yeast is never totally removed and so this beer is particularly robust with respect to flavour stability. There is, however, something of a dilemma here because to achieve satisfactory filtration, beer going to the filter must contain < 0.2 million yeast cells per ml of beer. It follows then that the bulk of the yeast must be removed from the beer following primary and secondary fermentation and before filtration. Removal of yeast from beer encompasses a study of the processing of beer from the main bulk of the maturation vessel and of the processing of 'tank bottoms' both to remove the yeast and recover the entrapped beer and so reduce process losses.

15.5.1 Removal of yeast and beer recovery

The characteristic that allows successful removal of yeast from beer is that of flocculation (Chapter 11). This characteristic varies considerably between different yeast strains. Generally ale yeasts are strongly flocculent and separate easily at the end of fermentation. Some lager yeasts exhibit poor inherent flocculence and so are difficult to separate. In this situation more intensive processing will be required. There is also the increasing problem of the disposal of the waste yeast once sufficient has been recovered for re-pitching. In this section the techniques of separation and removal of yeast are discussed, with the objective of preparing the beer for filtration and recovering beer entrapped in the yeast. The management of yeast with respect to collection and re-use is discussed in Chapter 12. The removal of yeast can be effected by sedimentation and fining, centrifugation, and filtration. Sedimentation and fining provides yeast for re-pitching but also results in the settlement of surplus yeast in the bottom of the tank where it will trap beer and produce 'tank bottoms'. These tank bottoms will require further processing to separate yeast and recover the beer.

Sedimentation and fining

The sedimentation of yeast cells in a fermentation or maturation vessel obeys Stokes' Law:

$$V = 2r^2(\rho - \rho_2)g/9\eta$$

where V is the settling rate, r is the radius of the particle, ρ is the density of the particle, ρ_2 the density of the surrounding medium, η the viscosity coefficient of the medium and g is the gravitational constant. The natural settling velocity for yeast has been calculated as 2.37×10^{-6} m/s. Using this figure it is possible to calculate the theoretical times for yeast to settle in tanks of different depths designed to hold the same volume of beer. If a horizontal tank to hold 2,500 hl (1,500 imp. brl) of beer is 10 m (about 33 ft.) high, then a vertical tank to hold a similar volume would be 30 m (100 ft.) high and sedimentation time would be three times as long. This illustrates a potential problem with natural settling times in vertical tanks which can now hold up to 4,000 hl (2,500 imp. brl) when the theoretical time of settling would be several weeks. This is usually unacceptable for modern intensive processing when it is necessary to prepare beers to filter in a matter of

days from the end of primary fermentation. As noted, considerable effort has been directed to accelerating the flavour maturation of beer and the development of haze stability. The separation of yeast cannot be allowed to become rate limiting.

Considering Stokes' Law from the viewpoint of sedimentation of yeast in beer, it would be difficult to lower the viscosity of the solution without a detrimental effect on beer quality. Likewise to create a marked difference between the density of the particles and the surrounding beer could alter the path of flavour maturation. An obvious method to improve the rate of sedimentation would be to increase the value of the factor $2r^2$, i.e., to increase the size of the yeast cells by agglomeration, i.e., causing them to clump together. This can be achieved by the use of isinglass finings. Isinglass finings are prepared from the dried swim bladders of certain fish (often sturgeon), which live in the estuaries of tropical rivers such as the Mekong and the Amazon (Leach and Barrett, 1967). To cope with large changes in water density as a result of experiencing fresh and salt water conditions alternately these fish develop very large bladders to adjust their buoyancy. These bladders are composed of almost pure collagen and they are one of the purest forms of protein found in nature. An isinglass solution is obtained by soaking the dried bladders in dilute solutions of cold tartaric, sulphurous and sometimes malic acid for periods up to six weeks (a process known as cutting). A turbid, colourless, viscous solution results, which contains soluble collagen, gelatine, (the denaturation product of collagen) and some insoluble material. Only the soluble collagen contributes to fining action and methods are available for determining the collagen content of fining solutions (Leach and Barrett, 1967).

Effective fining is achieved as a result of the positive charge on the collagen molecule that exists as a triple helix of complex stereochemistry rich in basic amino acids. Yeast cells are thought to flocculate as a result of surface proteins (lectins) bridging with carbohydrate side chains (mannan) on neighbouring cell walls (Shiel, 1999). It has been suggested that isinglass functions as an extracellular lectin with the carbohydrate moieties on yeast cell walls bearing a negative charge bridging to $-NH_3^+$ sites on the collagen molecule. In this way yeast cells will clump together and so the factor $2r^2$ in Stokes' Law will be enhanced with a corresponding increase in sedimentation rate. Breweries can use isinglass either as a liquid purchased from the manufacturer or as shredded swim bladders ready for cutting, with acid, in the brewery.

Larger molecules of soluble collagen are likely to be more effective at fining than smaller molecules. Large molecules will have more charged sites per molecule and therefore will react more readily with and cross-link the negatively charged yeast cells. Finings from different sources do not differ much with respect to total charge or charge distribution but the constituent collagen molecules do differ in size and size distribution. The size distribution is a function of the ease with which collagen is broken down by acid and the extent to which aggregates of molecules are held together by weak physical and chemical forces.

The collagen triple helix forms a long rigid rod of 1.5 nm diameter and the individual chains exhibit frequent sharp twists owing to the presence of adjacent imino acids, proline and hydroxyproline. As a result of the high hydroxyl group content there is strong hydrogen bonding between the three chains. Young tissues contain monomers of 300 nm length and 300,000 molecular weight.

The molecular size of the soluble collagen can be estimated by measuring the intrinsic viscosity (Leach and Barrett, 1967):

$$[\eta] = KM^\alpha$$

Table 15.1 Comparison of fining properties of isinglass from different sources (proportion of effective finings derived from isinglass = $A \times B/100\%$) (Leach and Barrett, 1967)

Type of leaf	Form	Soluble nitrogen (%) A	Soluble collagen (%) B	Intrinsic viscosity $[\eta]$ (dl/g)
Karachi	Flock	80	86	15.4
Karachi	Shredded	78	96	21.9
Brazil Lump	Flock	81	97	18.2
Brazil Lump	Shredded	84	93	18.7
Long Saigon	Flock	62	87	16.5
Long Saigon	Shredded	57	92	2.6
Round Saigon	Shredded	97	94	26.5
Penang	Shredded	20	98	16.8

where K is a constant depending on the particular solute/solvent system, M is the average molecular weight and α is a constant dependent on molecular shape and rigidity, for isinglass α is approximately 2

$$\therefore \sqrt{\eta} = KM$$

Intrinsic viscosities are independent of concentration and are high for finings compared to proteins in general. If beer is easy to fine then in citrate solution $[\eta]$ should be >16 and it is found that different types of isinglass show little difference in fining action. Beer that is more difficult to fine needs finings where $[\eta]$ is >20 and then differences are manifest between different forms of isinglass (Table 15.1). Collagen rapidly denatures to inactive gelatine when the temperature rises and fining solutions must be stored at temperatures of $4\text{--}10^\circ\text{C}$ ($39\text{--}50^\circ\text{F}$). Finings can be used effectively at temperatures up to 14°C (57°F) and work best when the temperature of the beer is rising slightly. This particularly applies to the use in cask beer when the finings are normally added at racking prior to despatch from the brewery (Chapter 21).

The use of isinglass finings in the preparation of brewery conditioned beer is not universal. It is largely a UK practice deriving from its effectiveness for cask beer. There is, however, renewed interest in the USA and the use of finings is increasing in Australia and Africa. Isinglass finings improve foam stability of beer by removing lipid material such as fatty acids and phospholipids, which are foam negative. This is an important secondary characteristic. The use of isinglass along with silica hydrogel has also recently been described (Shiel, 1999) and improvements in filter runs (by as much as threefold) and actual beer shelf-life were demonstrated. This seems likely to be as a result of the huge removal by isinglass of particles $< 4.5\mu\text{m}$ in diameter that will cause blockage of the filter and have the potential to cause haze in the beer.

Sedimentation of yeast in the presence of isinglass is rapid and compact easily removable tank bottoms are formed. This may require further processing by centrifugation or filtration to recover entrapped beer and finally separate the yeast if this is deemed economically sensible. It is clearly established (Shiel, 1999) that isinglass is completely removed during the brewing process and is not detectable in finished beer.

Centrifugation

The other powerful component of Stokes' Law is the effect of the acceleration owing to gravity. Centrifuges increase the gravitational force and so will allow more rapid

separation and removal of the yeast and other particles. Centrifuges are often used where isinglass finings are not used or they are used in conjunction with isinglass to separate yeast and beer in tank bottoms. A centrifuge operating at 5,000 rpm can effect an 8,000 increase in the gravitational force. The general relationship being:

$$g = \omega^2 r$$

where g is the gravitational force, ω is the rotational speed in radians/second and r is the radius in metres.

Sedimentation of the particles is also enhanced if the settling distance is reduced and this is an important feature of centrifuges. Centrifuges were developed from considerations of the behaviour of solids and liquids, and liquids of different densities in balanced tanks. If such a balanced tank is rotated about its vertical axis centrifugal force supplements the acceleration owing to gravity. Discs can be inserted in the centrifuge to reduce the path distance of sedimentation. Two main types of centrifuge are now used in breweries for the separation of yeast from beer prior to filtration, self-cleaning clarifiers and decanter clarifiers. Self-cleaning clarifiers can operate at relatively low solids contents to process complete tanks of beer, say between fermentation and maturation, when other means of yeast separation such as isinglass finings and sedimentation are not available or are not fast enough. They do not operate well on tank bottoms where the solids content can be very high. In this situation the decanter machine would be used.

- **Self-cleaning clarifiers.** In this type of centrifuge the solids are discharged at intervals whilst the centrifuge is operating at full speed (Fig. 15.9). The bowl contains discs separated by spaces of 0.5–2.0 mm (0.02 to 0.08 in.) by distance pieces known as ‘chaulks’. The yeast and other solids slide on the disc surface to the periphery and collect on the surface of the bowl. Clarified beer moves towards the centre of the machine and is pumped to the next processing stage, which is normally the maturation vessel when the centrifuge is inserted in the line between fermentation and maturation vessels. Depending on the solids load the rate of operation can vary from 40 to 600 hl/h. Yeast is removed by a mechanism whereby the spinning bowl separates momentarily into two parts at the rim and the solids are ejected. This ejection can be on a simple pre-determined time basis, irrespective of the presence of sludge, in which case beer losses can be high. The self-sensing type of machine uses a hydraulic differential pressure

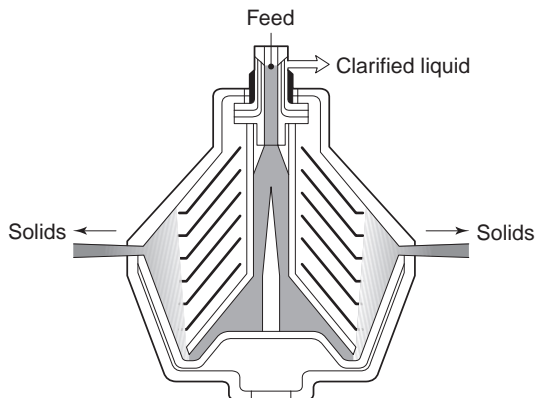

Fig. 15.9 Self-cleaning clarifier centrifuge (Hough, *et al.*, 1982).

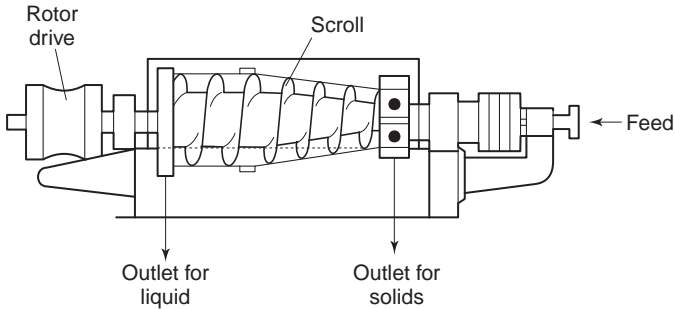

Fig 15.10 Decanter centrifuge (based on drawing received from Alfa-Laval Ltd.).

mechanism for sensing the accumulation of solids in the bowl. These machines offer better control of beer losses but must be constantly maintained. A third system works by optically monitoring the clarity of the beer leaving the machine.

- **Decanter clarifiers.** If the solid content of the beer to be processed is very high, as can be the case in tank bottoms (up to 60% by volume), a decanter centrifuge can be used (Fig. 15.10). These machines employ a rotating screw in a casing with discharge of solids at one end and processed beer at the other. They normally operate at speeds of 40 hl/h.

Centrifuges have a number of advantages for yeast removal and clarification of beer. They have a small space requirement and can be sterilized and maintained sterile. They can be hermetically sealed and this is essential to exclude oxygen. Fitting seals achieves this where the rotating parts of the machine adjoin the stationary parts. Centrifuges have no requirement for filter aids and no active adsorption is involved. If a constant solids load is presented it is possible to operate a centrifuge continuously for an indefinite period. Yeast separated by centrifugation varies between 13 and 25% dry matter.

Centrifuges have a very high requirement for electrical energy. There is a high inertia of the rotating parts and when slurry is discharged an equivalent volume of beer entering the machine is brought to rotational speed in a very short time. Motors have to be sized to meet these maximum loads, which on a 200 hl/h centrifuge would be 22.5 kW. The normal running rate of a centrifuge will consume about 0.35 MJ of energy per hl of beer processed. Centrifuges are noisy, frequently exceeding 85 dB(A) and so ear protection must be worn when inspecting or working on them. This sometimes deters maintenance and inspection. The machines are complex and difficult to maintain and spares are costly. These are real disadvantages in a modern brewery operating at low fixed cost. A further problem is the rise in temperature of the beer and yeast, which occurs during centrifugation (up to 3 °C, 5 °F). This can lead to a loss in carbon dioxide and a need to re-chill the beer. The physiological condition of the yeast is adversely affected by shear forces and the temperature rise and yeast collected by centrifugation is far less suitable for re-pitching than that collected by natural sedimentation.

Filtration

Yeast can be separated from beer and beer recovered by various types of filtration: the yeast press, rotary vacuum filtration and cross-flow filtration. Filtration techniques are normally used for the processing of tank bottoms. Tank bottom beer (sometimes called ‘barm ale’) may represent 1–3% of the total volume of the beer in the tank. It is thus a high process loss to discard the whole of this beer. This is often not of such good quality

as the bulk of the beer in the tank. It usually has a higher pH value and contains more amino nitrogen and higher alcohols. Recovered beer must be blended at some stage with primary tank beer. This should be carried out as early as is possible in the process as the recovered beer will contain yeast autolysate.

The point of addition will vary from brewery to brewery depending on the available equipment and the quantity of beer. A good point of addition is the beginning of fermentation when the actively fermenting pitching yeast will quickly absorb the metabolic products of the autolysed yeast in the recovered beer with no deleterious effect on overall beer quality. Earlier additions into the brewhouse are also possible. The capital cost of making these additions and indeed recovering the yeast may be high and the overall economics of the process must be assessed when deciding on the optimum method in a particular brewery. In many parts of the developed world the costs of treating effluent containing yeast and beer are so high that it will be essential from a financial viewpoint to separate yeast and recover beer from tank bottoms before discharging effluent to drain (Chapter 3).

- **Yeast press.** In traditional ale brewing in the UK it was common practice to press yeast after skimming from the fermenter to separate it from barm beer. The pressed yeast was stored as a dry cake in a refrigerator or was slurried in chilled water until reused. This was a good way to recover barm beer for addition back to the process and the pressed waste yeast in a convenient form to sell for the manufacture of yeast extracts or animal feed. Yeast was also sold to the distilling industry in this form. Yeast presses are made of gun metal and contain fabric cloths. Two cloths form a chamber on either side of a backing plate. The yeast slurry is pumped into the chambers and the beer recovered from channels in the backing plate. Presses are labour intensive and slow, requiring manual cleaning of cloths and two-man operation for yeast removal. In many breweries the traditional press has been discarded and the yeast is used and stored as barm (i.e. as a slurry in beer).

There have been recent developments in yeast press design demanding a reconsideration of this technique for tank bottom processing. Inflatable diaphragm plates made of polypropylene have been introduced which can squeeze the cake and considerably shorten the time of pressing. New presses can be in-place cleaned at 80°C (175 °F) and can be operated by one man. A fully automated press has also been described (Anderson *et al.*, 2000) in which a stack of vertical plates is used with a continuous polypropylene cloth driven by power rollers fed around each of the plates.

In the modern press the pressure applied rises from 4 to 19 bar (60–280 lb./in.²) as the chamber is filled and kieselguhr or perlite is sometimes added to improve filterability. The recovered beer can contain 0.1 to 0.5 × 10⁶ yeast cells/ml of beer and the concentration of the pressed yeast is between 25 and 40% dry weight. The market value of pressed yeast varies but it can normally be sold at a profit. The beer is bitter and yeasty and contains high levels of amino acids and polyphenols. It can be added at the start of fermentation but in some breweries it is pasteurized before addition. If possible the beer should be added after wort boiling but before wort cooling and pitching. Experience shows that beer from a yeast press should not be added at a greater rate than 5%.

- **Rotary vacuum filter (Fig. 15.11).** This machine can operate continuously and consists of a rotating drum covered by a filter sheet on which is deposited a pre-coat of perlite or kieselguhr. Beer is sucked into the drum and yeast collects as a layer on the surface, which is then removed by knives to a tank underneath the filter. The

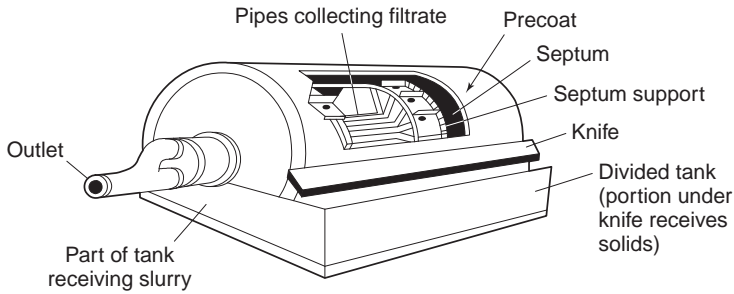

Fig. 15.11 Rotary vacuum filter (Hough *et al.*, 1982).

concentration of the recovered yeast is usually 10 to 25% dry matter. The beer has similar properties, although it contains more oxygen, than that from the yeast press and can be returned to the process in a similar way.

- **Cross-flow filter.** In this system the yeast/beer mixture is circulated under pressure over a membrane. For the system to be successful shear at the membrane surface is necessary to prevent fouling and a mechanism for the removal of solids is essential. Shear can be created by high volume flow at the membrane surface, but these systems have not always been commercially successful because of the high energy input needed and the high pumping rate leading to yeast cell damage and consequent adverse flavour effects in the beer. A device has been described (Chalmers and Haughney, 1998) in which the shear at the membrane surface is created mechanically by vibrational energy. The basis of the design is the use of a torsional spring mass system for the creation of vibrational shear at the membrane surface (Fig. 15.12). A motor rotates a shaft with an eccentric weight. The motion of this causes the motion of a second weight, which has a relatively high mass moment of inertia, this is called the seismic weight. The motion of the seismic weight is translated through a torsion bar or spring to a membrane element assembly. The element assembly vibrates at a frequency of 50–60 Hz and the energy requirement is 0.03 to 0.15 kW/m².

The membrane assembly can contain up to 40 m² of membrane area and it is made to operate three streams: feed, permeate (or filtrate), and retentate. The element assembly has a top and bottom end plate and membrane elements with spacers on the inner and outer diameter. The spacers provide an open channel for the distribution of the feed fluid (beer containing yeast, e.g., tank bottoms) across the membrane from the outer diameter to the inner diameter. As this happens the filtrate (beer) passes through the membrane and is directed to a centre channel. Fluid that does not pass through the membrane (yeast) is concentrated and leaves the membrane element assembly as the retentate.

Membrane quality is very important for the success of the system. Membranes have been made from ceramic tubes and hollow fibres or flat sheet polymers. Initial trial work with the vibrating membrane filter used a PTFE membrane, each element of which was 0.4 m²; a ten element system therefore presented 4 m² of separating membrane. Beer/yeast slurries of up to 80% solids (by volume) were processed. For tank bottoms where the solids content was > 60% by volume, dilution with water improved performance. Loss of carbon dioxide can be prevented by pressurizing the system and operating with a back pressure on the permeate of 1.0 to 1.4 bar (15–20 lb./in.²). Yeast in lager and ale tank bottoms was concentrated to a dry solids content of 20% (80% by volume). Pressure drop across the membrane was not significant and

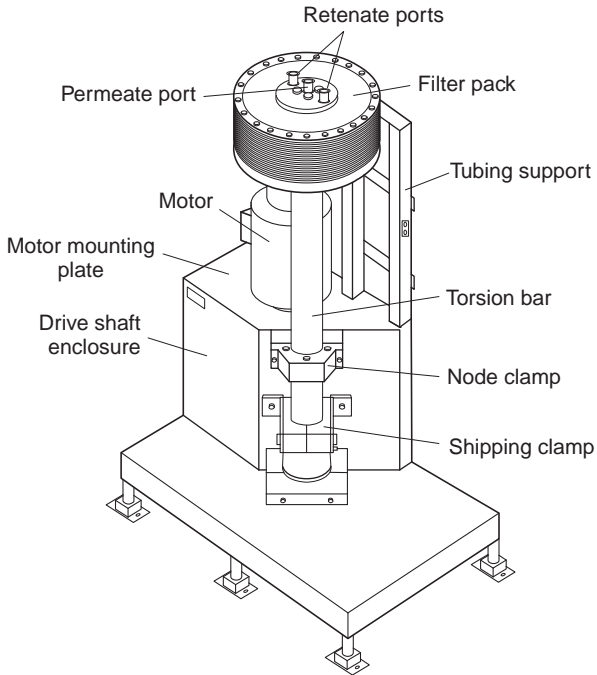

Fig. 15.12 Vibrating membrane filter (Chalmers, and Haughney, 1998).

successful permeate flows were obtained at pressures of 0.8 bar (12 lb./in.²). Commercial systems have now been developed that can operate at average flow rates of up to 2,500 l/h which could serve a brewery producing 4,000,000 hl of beer a year of which 6% was barm (tank bottoms). Cleaning the membrane assemblies can be effected with caustic soda solutions (0.2M at 60 °C; 140 °F). The process has an extremely low energy requirement of 0.004 kWh/l of recovered beer. This factor, coupled with the compactness of the machine, the ease of automation and low manpower input makes the use of a vibrating membrane filter an attractive option for separating yeast and beer in barm and tank bottoms.

15.5.2 Beer filtration

The final process to consider in beer treatment, prior to packaging, is filtration. This is the clarification of the beer to a standard that is acceptable for sale. The process involves the removal of any remaining yeast cells and the removal of precipitated protein and polyphenol haze material. The beer must be rendered stable so that visible changes do not occur during its commercial (shelf) life, which could be up to 52 weeks from the date of packaging. To be successful, beer coming onto the filter must contain < 0.2 million yeast cells/ml of beer and so the processes discussed above are crucial for the success of the final beer filtration.

The driving force for filtration is the pressure difference between the filter inlet and outlet. Pressure is always greater at the inlet and the pressure difference is an indicator of how much the filter is resisting filtration. An increase in this pressure difference indicates the approach of the end of a filter run. In commercial brewery practice this is an important factor and long filter runs are essential to overall brewery efficiency.

A very important factor in successful filtration is the chilling of the beer. The lower the temperature the more cold trub and chill haze will form. Filtration will remove this material, provided that the beer temperature does not rise in the filter itself. Beers emerging from maturation must therefore be maintained at -2 to -1°C (28 – 30°F) through filtration. The turbidity (see Chapter 19) of the beer leaving the filter must be $< 0.5^{\circ}\text{EBC}$. In good filter practice losses of colour, extract, bitterness and foam potential should be minimal.

Care must also be taken to avoid oxygen pick-up after maturation and during the filtration process. At the end of maturation the oxygen concentration should be $< 0.01\text{ mg/l}$. This concentration can be maintained with sound practice. Deaerated/deoxygenated water must be used for introducing powder pre-coats on powder filters and carbon dioxide is used as the counter pressure gas to move beer from maturation through to the filtration process. Air must be completely removed from all pipework before the passage of beer.

As with beer sedimentation there have been attempts to define filtration in mathematical terms following empirical studies. It was found in 1856 that:

$$Q = \varphi \frac{PA}{LM}$$

where Q is the flow rate in ml/second, φ is the permeability factor, P is the pressure differential in dynes/cm², A is the area of the filter medium in cm², M is the viscosity of the liquid in poises, and L is the thickness of the filter medium in cm. Filter throughput may therefore be increased by increasing φ which relates to the composition of the filter material. Alternatively, the applied pressure and filter area may be increased and the filter thickness and liquid viscosity decreased, this latter factor cannot be achieved in practice without increasing temperature, which could result in the re-resolution of haze polymers. A high viscosity is sometimes indicative of the presence in solution of high molecular weight β -glucan, α -glucan or yeast polysaccharide which will adversely affect filtration and if this is the case the cause should be sought in examining malt quality and brewhouse performance. In considering any type of brewery filtration system the above equation should be studied to optimize performance.

Different mechanisms of filtration can be used:

- Sieving or surface filtration in which the particles are trapped in pores in the filter medium and retained in a layer. Filtration quality improves with time but the volume flow decreases continuously.
- Depth filtration in which a separation medium, e.g., kieselguhr is used on a support and which causes the particles in the beer to take a very elongated route through a large surface area. The particles are retained by mechanical sieving because of size and will gradually block the pores in the medium and so reduce flow rate and the particles can also be retained by adsorption as a result of electrical charge effects.

Traditionally, surface filtration in breweries was associated with sheet filters. However, adsorption can occur on some sheets as demonstrated when some yeasts and bacteria fail to penetrate sheets when the pore size should permit it, as the fibres hold the negatively charged micro-organisms electrostatically. Breweries frequently employed double pass filtration where the beer was filtered twice through discrete systems. This could be two sets of sheet filters of decreasing pore size or a depth filter followed by a sheet filter (called a polishing filter). These systems were sometimes associated with high beer losses and the addition of oxygen to the beer and there is increasing use of single

pass filtration to prepare beer for packaging. Of course if sterile filtration is to be used prior to packaging then there will be a separate filter for this purpose (Chapter 21). The two different mechanisms of filtration can be effected using sheets or by using cloths on which a medium (powder) is deposited to create the depth. Genuine surface filtration is also achieved with membranes (Chapter 21), which can be made of many polymers, e.g., polyamide, polyethylene, and polycarbonate.

Sheet filtration

The standard filter sheet in breweries is 60×62 cm and the largest normally 100×100 cm. A large single-ended filter press would have 240 filter plates allowing a filtration rate of 120 hl/h. This low throughput rate has limited the use of sheet filtration for primary filtration in large breweries. Sheet filters are now usually used only as second polishing filters following depth filtration with powders or are dispensed with completely. There have been developments in the design of filter plates to ensure the maximum surface area of filter sheet is presented to the beer (Fig. 15.13). Stainless steel plates are now usually used having corrugated inserts as supports. Flow rates of > 2.0 hl/m²/h have been achieved.

Filter sheets were originally made from a mixture of cellulose and asbestos fibres. Sheets have also incorporated kieselguhr for over 70 years. Recently perlite, glass fibres and cotton fibres have been used. Asbestos is not now used because of the carcinogenic properties of some types of asbestos. It is fair to comment that the elimination of the use of asbestos took a long time in many breweries. Asbestos was useful because it offered adsorption through electrical charge as well as surface filtration. This has been replaced in some applications by the incorporation into the sheet of aluminium oxide or zirconium oxide fibres. PVPP can also be incorporated into filter sheets to impart additional stabilization to the beer by removal of polyphenols (15.3). In large throughput systems washing the sheet with a solution of 0.5% sodium hydroxide regenerates the PVPP.

Sheet filters generally operate at low flow rates. If attempts are made to increase the flow rate, pressure can force yeast and haze particles off the fibres and through the filter into the beer. For this reason pressure differentials not greater than 0.7 bar (10 lb./in.²) are often maintained. When this pressure differential is exceeded then sheets are cleaned by back-washing or are replaced. Sheet filters are often sterilized with steam (0.6 bar; 9 lb./in.²).

Sheet filtration does, therefore, have a number of drawbacks. The sheets cannot be regenerated indefinitely and so operating costs are high. The filter occupies a lot of space if substantial throughput is required and it is not easy to automate. It is also very sensitive to variable solids levels in the beer and will quickly block. As a primary beer filter the sheet filter has usually been replaced by the powder filter.

Powder filtration

The most successful and cost effective beer clarification is achieved by powder filtration. This was developed from the earlier pulp or mass filtration in which the mechanism is primarily depth filtration. Many breweries employ this system for single pass filtration and are able to deliver beers to packaging consistently at < 0.5 °EBC haze units. In a powder filter the powder (filter aid) is coated onto a support and provides a tortuous path through which the beer passes giving many opportunities for the trapping and adsorption of particles.

Two types of powder are commonly used: kieselguhr or perlite.

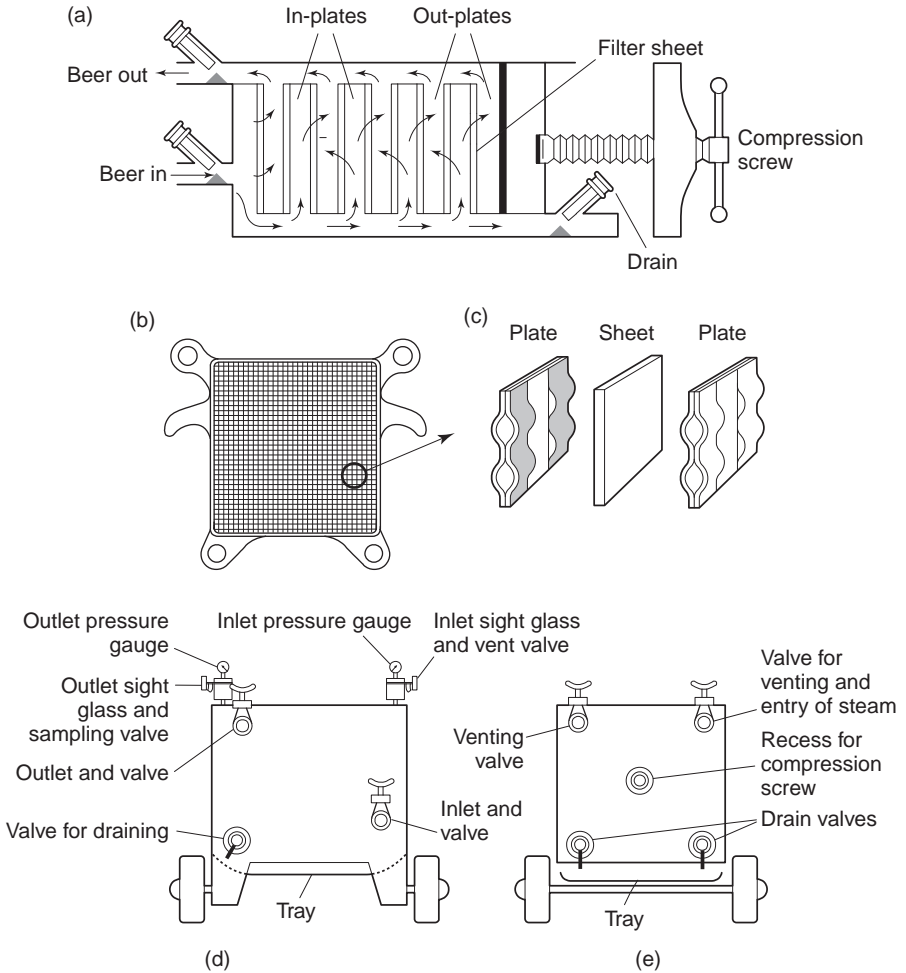

Fig. 15.13 Details of a sheet filter; (a) vertical section, (b) single plate front view, (c) alignment of plates and sheets, (d) control end of machine, (e) compression end of machine (Hough *et al.*, 1982).

- Kieselguhr is a diatomaceous earth, which is mined from Miocene period deposits in Europe and North and South America. It consists of skeletons of marine algæ containing silicon dioxide. Kieselguhr powders for use in brewing are prepared by drying and milling the mined raw material. Most effective filtration was achieved with the use of calcined kieselguhr prepared by heating the raw material in rotating drums at 600 to 800 °C (1,100–1,450 °F). However this substance is classified as highly dangerous when inhaled and can give rise to the disease of silicosis. Equipment is needed for automatic slitting of bags and transfer to slurry tanks to avoid manual handling. Uncalcined kieselguhr, prepared by drying at < 400 °C (750 °F) represents only a moderate risk and is now usually preferred. However, some uncalcined kieselguhr can contain traces of iron and other metals. Numerous grades of kieselguhr are produced from fine through to medium and to coarse. The finer the kieselguhr the better is the clarification but the speed of filtration is less. Coarser grades give a rapid flow rate but poorer clarification. Kieselguhr usage varies from 70 to 220 g/hl. It is an

expensive product and it is also expensive to dispose of as slurry, usually to landfill sites where it is an unsatisfactory uncompacted infill.

- Perlite is a volcanic material, mostly composed of aluminium silicate, obtained from Greek islands. Raw perlite is heated to about 750 °C (1,400 °F), which causes bursting of the particles yielding glassy structures. These are milled to a free flowing powder, which is about 30% lighter per unit volume than kieselguhr. Perlite represents a low risk to health but, because of its low density, it disperses easily in the air and creates nuisance dust. At low pH values (< 5.0) perlite can release iron and so its use was formerly restricted to some systems of wort clarification. However, increasing concerns over the health risks associated with the use of kieselguhr have renewed interest in its use in powder beer filters.

Silica gel is now also used as a filter aid in admixture with kieselguhr. This has the advantage of providing stabilization of the beer as well as clarification (Section 15.3) and there are considered to be no health risks in its use.

In all powder filters it is necessary to build up on a cloth or perforated septum a thickness of powder that will permit the filtration of particles from beer. This is called a pre-coat. The cloth or septum will have a pore size much greater than the 2–4 μm size of the filter aid (perhaps 60–100 μm) and so if the filter aid were simply dosed into the beer it would pass through the filter without effecting any removal of particles. A coarse variety of powder is slurried with water or sometimes beer and pumped into the filter where it forms an even layer, called the first pre-coat, on the septa. About 600–800 g/m² of powder is used for this layer. If this is kieselguhr this will represent about 75% of the total pre-coat. This operation is then repeated with a finer grade of powder to form a second pre-coat. The total pre-coat layer will be 1.5–3 mm thick.

It is important to achieve a uniform distribution of the pre-coat, with no thin regions, to prevent weak spots allowing haze particles to pass. Recycling the slurries of kieselguhr occurs until the emerging liquid is clear (< 0.5 °EBC). Beer is then pumped into the filter, avoiding pressure surges. At frequent and predetermined intervals further kieselguhr is introduced as body-feed into the beer flowing to the filter. Body feed dosing rate is about 100 g/hl of beer. This slurry builds up progressively on the pre-coat presenting a fresh surface to the beer requiring filtration (Fig. 15.14). There is a continual increase in the pressure differential from inflow to outflow of the filter which, for satisfactory filtration, should be about 0.2 bar (3 lb./in.²)/hour. Eventually the cavities of the filter become completely filled with kieselguhr when the pressure differential may be about 4 bar (60 lb./in.²). Filtration stops and the filter is normally opened up, the used kieselguhr dumped and a fresh pre-coat is applied. Long filter runs are desired and with the right choice of the grade of the kieselguhr powder this is frequently achievable. Rapid increases in pressure differential (≧ 0.2 bar/hour) indicate problems usually related to high solids in the beer coming on to the filter (say > 0.2 million yeast cells/ml).

The avoidance of oxygen pick-up into the beer during filtration is crucial. Kieselguhr suspensions in the dosing vessels are usually deaerated with carbon dioxide before pre-coating. Several powder filters are in common use, plate and frame, vertical leaf, horizontal leaf, and candle filters.

- Plate and frame filters. The plate and frame filter is widely used in Europe. The filter consists of a succession of vertically dispersed plates each covered with a cellulose filter sheet folded at the top of the plate so that both sides of the plate are covered. Each plate alternates with a frame that will receive successively the pre-coats and the beer plus body-feed. The beer passes through the kieselguhr bed, then the sheet and

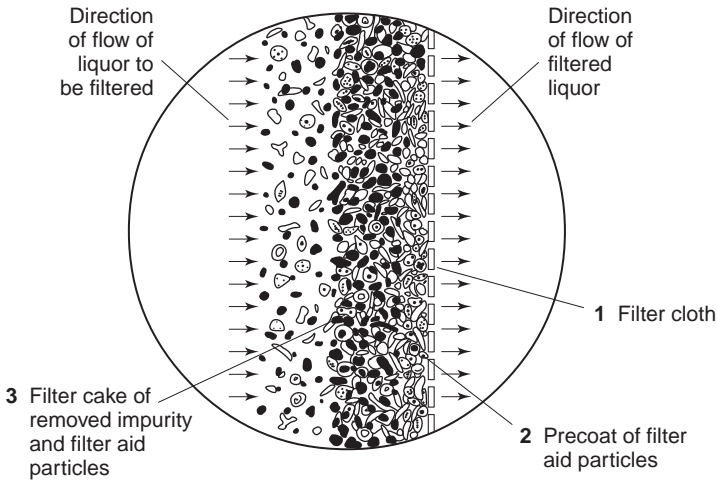

Fig. 15.14 Principles of kieselguhr filtration (Hough *et al.*, 1982).

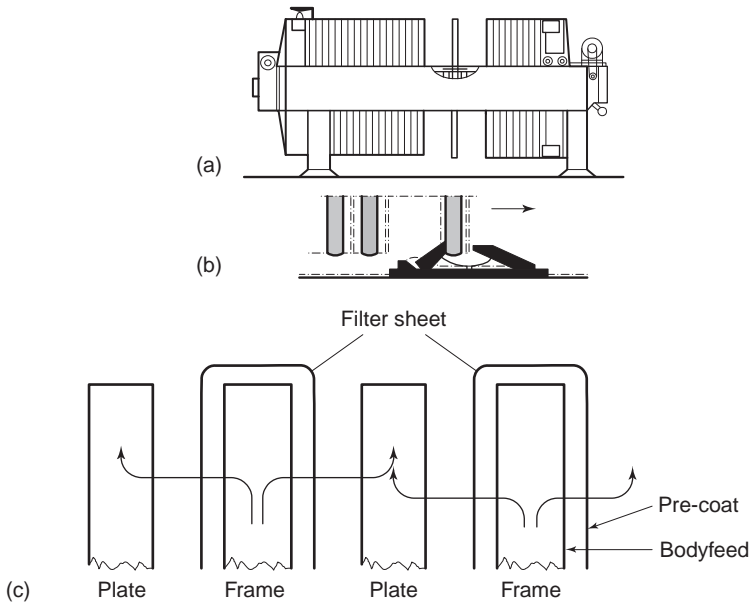

Fig. 15.15 Plate and frame filter; (a) side view, (b) automatic mechanism for moving individual plates for opening and closing, (c) arrangement of plates and frames and the flow of beer. (Courtesy of Alfa-Laval Ltd.).

into the void in the plate from which it discharges (Fig. 15.15). The sheets are washable and have a long life. After filtration the plates are separated and the kieselguhr is dislodged from the sheets by spraying. In some plate and frame filters the sheet is protected by a disposable cellulosic ‘nappy liner’, which does not add to pressure differential but does prolong the life of the sheet and aids kieselguhr disposal.

- **Leaf filters.** Leaf filters (or screen filters) have a series of stainless steel leaves fitted either vertically or horizontally inside a filter body (Fig. 15.16). In a vertical leaf filter both sides of the support are coated with filter aid whereas in the horizontal leaf filter

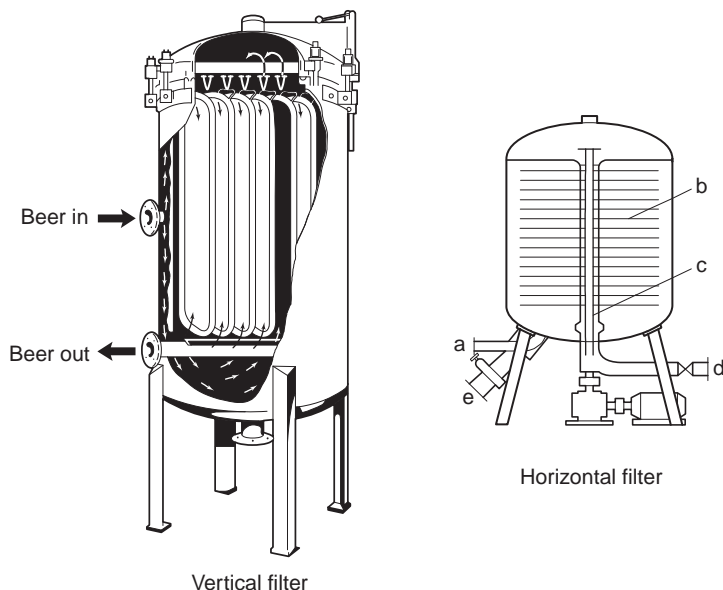

Fig. 15.16 Vertical and horizontal leaf filters; horizontal filter: (a) beer inlet, (b) filter support, (c) perforated shaft, (d) filtered beer outlet, (e) sediment outlet (Courtesy of Alfa-Laval Ltd.).

only the upper surface is used. The kieselguhr adheres to the stainless steel septa because of the pressure at which the beer is forced into the filter. Even coating of the supports is not easily achieved particularly with the vertical leaf filter in which the kieselguhr tends to slip downwards. A new type of support for horizontal leaf filters has been described (Oechsle *et al.*, 2000). This is a stainless steel membrane of 0.4 mm gauge and an optimized slot width of 35 μm and a length of 2 mm. The slots widen towards the filtrate side, which reduces blocking. In trial work this support was effective in beer filtration without the use of an initial coarse kieselguhr pre-coat. This resulted in major savings in kieselguhr use as the first pre-coat can be up to 800 g of kieselguhr/ m^2 of filter. Time was also saved and longer filtration cycles were demonstrated with beer clarities better than the controls delivered from conventional pre-coat filtration.

There is also the potential for health improvements with the elimination of the coarse kieselguhr pre-coat, which in some breweries is composed of calcined kieselguhr, which is the most risky for health. Increasingly breweries have to cope with the filtration of more different beer brands, some in very low volumes. This is a result of greater consumer pressure and the proliferation of licence brewing where some companies will brew another company's brands. Losses must be minimized and the flexibility and automation of the filter is very important. Single pass filtration in a horizontal leaf filter is effective in achieving these aims (Thilert, 1999). Cleaning leaf filters is effected by spraying the leaves and filter body and in the case of the horizontal filters spinning the leaves to deposit the spent kieselguhr into a holding tank. Sometimes the last remains of the kieselguhr must be removed by pressure spraying from a built-in spray bar as a result of which this small amount of material goes down the drain. This volume must be minimized because entrapped beer will contribute to COD of the effluent and the powder will raise suspended solids, both important factors in the charging formulæ for effluent in some countries (Chapter 3).

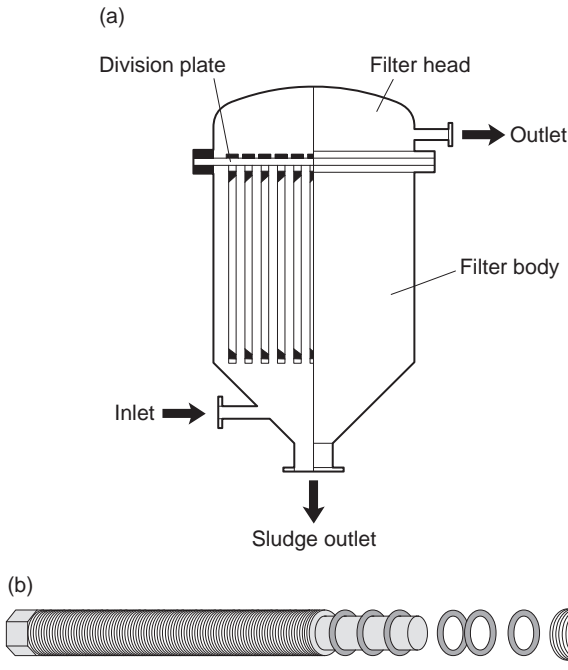

Fig. 15.17 Candle filter or Metafilter; (a) candle filter, (b) detail of single candle (Hough *et al.*, 1982).

- **Candle filters.** A candle filter is a cylindrical, vertical pressure vessel containing many filter elements (Fig. 15.17). Each element consists of a rod of Y cross-section around which annular discs are stacked. The discs are made so that liquid can penetrate between them and then flow along the channels between the holes in the discs and the recesses of the Y-section rod. Kieselguhr powder builds up between adjacent filter discs to provide the surface area for depth filtration. Between 500 and 700 candles can be arranged in a cylindrical housing to create a very large filter.

Views vary considerably on the relative advantages of different types of filter. It is difficult to draw firm conclusions but some principles emerge. To avoid losses and to avoid oxygen pick-up, single pass filtration should be used wherever possible. On this basis powder filtration is usually regarded as being superior to sheet filtration. Powder filters have been compared for a number of parameters (Harding, 1977). Flow rates through filters are usually about 5 hl/m^2 but slower rates will ensure more effective particle removal. Plate and frame filters are more easily pre-coated and less susceptible to pressure surges than leaf or candle filters but the greater volume of the filter means higher beer losses, an important factor.

Sterilization of the filter, usually achieved with steam, is easier in candle filters and leaf filters than in plate and frame filters which have a large mass of metal. Kieselguhr removal is easiest with the new generation of horizontal leaf filters. (Thilert, 1999). These filters are well suited to low volume filtration for a series of different brands with minimal losses and oxygen pick-up.

It is difficult to generalize on capital costs but candle filters are usually the cheapest and horizontal leaf filters the most expensive. The revenue cost varies considerably

depending on the conditions of use. Clearly any system avoiding the use of a first pre-coat (Oechsle *et al.*, 2000) may offer a lower cost advantage.

15.6 Special beer treatments

Many beers are brewed at a higher gravity (or alcoholic strength) than that at which they are subsequently sold. These beers are diluted after fermentation and usually after filtration just prior to packaging (Section 15.2.4). Fermentation at high gravity was considered in Chapter 12. Some beers are sold as low-alcohol or no-alcohol products and the alcohol is removed after fermentation. Low-alcohol beers can also be produced by changes to the mashing process or to fermentation and all types will be discussed in this section. There has also been interest in the sale of beers produced by freezing to remove water and yield a beer with a smooth flavour and elevated alcohol content. These are known as 'ice beers'. A further 'special' type of beer is the so-called diet beer, which has a very low dextrin level (but often high alcohol), and although this is not strictly a post-fermentation 'treatment beer' it will be reviewed in this section.

15.6.1 Low-alcohol and alcohol-free beers

The production of alcohol-free and low-alcohol beers has a long history and patents on the processes involved go back over 100 years. Marketing and sale of these beers has varied in intensity throughout this period. Low-alcohol beers were produced in considerable volume at the time of the First and Second World Wars as a result of the shortage of raw materials and prohibition in the USA from 1919 to 1933 stimulated production. There has been renewed interest, since about 1978, because of legislation relating to the driving of motor vehicles and health considerations leading to some beliefs in the advantages of drinking less alcohol. There is also a trade in the export of non-alcoholic beer to Islamic countries where the sale of alcohol is banned. These situations lead to the development of a healthy market and most major brewers included low-alcohol and alcohol-free beers in their product portfolios. The market for these beers has recently come under pressure both from aggressive marketing from soft drink companies and from so-called 'alcopops' in which alcohol is mixed with some type of fruit extract. This has led to brand losses and there are now fewer types of beer available. However the competition has resulted in marked flavour improvements in those brands which have survived. In 1992, in Europe, the market for low-alcohol beer was 4% of the total alcoholic drinks market but it has shown no growth since this time.

Legal definitions of what constitute low-alcohol and alcohol-free beer varies from country to country. A low-alcohol definition will allow an alcohol content of 0.5 to 1.2% v/v whereas an alcohol-free beer should contain < 0.5% v/v alcohol. Production methods for these beers involve either the removal of alcohol in a post-fermentation treatment or the restriction of alcohol production during the brewing process. Removal of alcohol can be effected by vacuum distillation, vacuum evaporation, dialysis and reverse osmosis. Restriction of alcohol production can involve choice of grist materials, control of mashing schedules, stopped fermentation, and use of special yeasts.

Vacuum distillation

In this process (Regan, 1990), the beer to be de-alcoholized is heated to 50 °C (122 °F) in a plate heat exchanger and is then de-esterified under high vacuum. Volatile components

evaporate from the beer and are collected in a mixing tank. The de-esterified beer is then separated from alcohol in a vacuum column at about 40 °C (104 °F) and passed to the mixing tank where it is recombined with the volatile components. This method has produced beers with sound flavours but is now seldom used because the high temperatures involved do tend to make the consistent production of high-quality beer difficult.

Vacuum evaporation

This process (Attenborough, 1988; Narziss *et al.*, 1992; Regan, 1990) has developed from considering the difficulties of vacuum distillation. The temperatures used are lower than with vacuum distillation and the residence time under evaporation is less. It is easier to produce de-alcoholized beers of consistent quality with this method. A process described by Alfa-Laval involves centrifugal evaporation. Beer is pumped over the internal surface of a rotating conical heat exchanger and forms a film (0.1 mm) over this surface. The beer remains in this position for 0.5 to 1.0 seconds and reaches a temperature of 30–40 °C (85–104 °F). The concentrated, de-alcoholized beer is collected at the periphery of the cone where it is drawn by suction to a cooler. The aroma compounds are retained in the beer by this technique and this is the real advantage compared to the vacuum distillation method. The alcohol evaporates and the vapour passes through the centre of the cone to a condenser. The process, taking only about ten seconds, is repeated several times if it is required to lower the alcohol content to < 0.5%.

An APV system utilizes a triple effect falling film evaporator. The maximum temperature of the beer is about 40 °C (104 °F) and the residence time in the system is three to five minutes. These plants are in wide use and can give throughputs of 200 hl/hour. Warmed beer is carefully heated in three evaporators in series and the alcohol vapour in each case is collected in a pressure reduction vessel and then condensed in a spray condenser. After this triple process the beer, at 0.3% v/v alcohol, is cooled in a heat exchanger counter-current to incoming beer, which is so warmed. The beer leaves the plant at about 1 °C (34 °F).

Dialysis

In this method (Attenborough 1988; Niefind, 1982; Regan, 1990) the alcohol is removed by pumping beer through a membrane at a pressure of just over 2 bar (30 lb./in.²). The membrane is normally a hollow fibre with a very thin wall. The membranes are collected into modules of several thousand and sealed at both ends. The beer is pumped uniformly through the membranes and the dialysate (water containing alcohol) passes through the hollow fibres in the opposite direction. The rate of dialysis is directly proportional to the concentration gradients formed and inversely proportional to the size of the molecules. Equilibrium is reached when the alcohol concentration is the same on both sides of the membrane. Alcohol is therefore removed from the dialysate by continuous distillation at reduced pressure and so the process of alcohol removal can continue. Separation of beer and alcohol occurs between 1 and 6 °C (33 and 43 °F) and so quality of the resultant de-alcoholized beer is good. However, important flavour esters pass out of the beer with the alcohol. The dialysate, therefore, passes to a rectification column for removal of alcohol. The alcohol-free fraction containing esters is reincorporated into the low-alcohol beer. This is a complex process and considerable skill is required to produce beers of consistent flavour. Nevertheless the process is in use throughout the world.

Reverse osmosis

This process uses filtration at high pressure (30 to 60 bar) through a semipermeable membrane. The membranes are made of cellulose acetate, nylon or other polymers and

allow the passage of small molecules such as water and ethanol and hold back the larger molecules. The high pressure used forces the water and alcohol against the natural osmotic pressure of the beer through the membrane. The flavour and aroma compounds mostly remain in the beer although in some systems the water/alcohol mixture (permeate) is rectified and the alcohol-free fraction, which does contain some volatiles, is added back to the beer. In other systems the permeate is used without rectification for sparging.

The high pressure used causes heating and the equipment must be cooled so that the beer temperature does not rise above 15 °C (60 °F). The membrane modules must possess a large surface area to achieve commercial flow rates of at least 25 hl of low-alcohol beer per hour. About 60 l/m²/h of flow is possible so to achieve the above capacity around 20 modules would be needed and the plant would be expensive. Cleaning the membranes is essential for optimum performance.

Control of mashing

Clearly, if mashing can be performed to produce a wort of low fermentability then there is the possibility of fermenting this wort to yield a beer of low alcohol content (Muller, 1990). These methods were formerly associated with intensely 'worty' flavours in the resultant beers which were cloying and not 'moreish'. To reduce worty flavour the amount of malt in the mash must be reduced and replaced with starchy adjunct, which can provide 40 to 70% of the extract. Mashing is carried out to restrict amylolysis, by using temperatures of 70–80 °C (160–175 °F), which produces high levels of non-fermentable dextrans. The pH value of the wort is also usually artificially lowered with the use of phosphoric or sulphuric acids. Used on their own, methods relying solely on the restriction of amylolysis are seldom successful for the production of non-alcohol beers and they have to be combined with further measures to control the fermentation. It is also essential to ensure vigorous wort boiling to lower the levels of aldehydes, which in the absence of normal levels of ethanol, will spoil flavour.

Control of fermentation

The essence of these methods is to lower ethanol production by restricting fermentation. This can be done by stopping yeast activity before fermentation is complete, by using a special strain of yeast, by temperature control, or by controlling contact time of the yeast with wort. Fermentation can be stopped early by removal of yeast by filtration or centrifugation or by using a plate heat exchanger to provide a thermal shock and so kill the yeast. These methods are difficult to control (Brenner, 1980). A flocculent yeast at low pitching rate must be used and these products require maturation for at least ten days at –1 °C (30 °F) to ensure an acceptable flavour.

In a patented so-called 'cold contact' process, yeast is mixed with wort at –0.5 °C (31 °F) for 48 hours and circulated to ensure good mixing (Schur, 1983). There is virtually no ethanol production but carbonyl compounds are reduced in concentration and so worty flavour is reduced. After yeast removal the product can be matured for packaging. Fermentation can also be controlled by special yeasts, e.g., *Saccharomyces ludwigii*, that ferment only glucose, fructose and sucrose, which comprise about 15% of the carbohydrate in an all malt wort. The resultant beer, therefore, contains <0.5% ethanol but tastes sweet because of the high residual maltose and maltotriose content.

The problem remains with any of these restricted fermentation methods that control is difficult and the beers often have a worty taste that limits their appeal. These problems can be reduced in continuous fermentation processes with immobilized yeast cells. A successful system is in use in The Netherlands (Mensour *et al.*, 1997) in which the yeast

is immobilized on DEAE cellulose in packed beds as a result of ionic binding between the negatively charged yeast cells and the positively charged carrier. Lactic acid is added to the wort before fermentation to lower the pH value to about 4.0 and so restrict the growth of bacteria. The wort thus treated is allowed to percolate through the reactor at -1°C (30°F). Under these conditions the yeast preferentially metabolizes glucose. Maltose and maltotriose are not easily consumed as a result of the repression by glucose of their transport systems. A product of $< 0.1\%$ alcohol is produced. It is low in carbonyl compounds but contains some esters associated with normal beers and has good flavour stability. The system requires cleaning and re-sterilizing twice a year. A similar system has been described (Aivasidis *et al.*, 1991) using sintered glass beads instead of DEAE cellulose as the support medium.

Use of spent grains

These methods (Attenborough, 1988) utilize spent grains to produce worts of low fermentability. The grains can simply be extracted with water or by acid hydrolysis or can be extrusion cooked. Fermentation is normally at a gravity of 8°P (32°Sacch). Again, these beers require long maturation times (at least 14 days) to yield acceptable flavours.

It is difficult to generalize on the best method to produce low-alcohol beer of acceptable flavour that will persuade the drinker to drink more of the product. De-alcoholized beers often contain lower concentrations of potential flavour-spoiling aldehydes than those produced by restricted fermentation but they lack the higher alcohols that can contribute positively to flavour. Further development of these drinks will take place only if the market grows.

15.6.2 Ice beers

Brewers have long experimented with ice beer. In Germany kegs of beer were deliberately 'frozen' in the winter when an ice wall would form on the inside of the container and an increasingly strong beer would result. These were dangerous beers to drink particularly as the starting point was often a bock beer of high gravity (16°P ; 64°Sacch)!

In the 1980s many brewers were interested in lowering costs as sales began to fall after the peaks of the late 1970s. One idea was to concentrate beer at the brewery by removing water and to reconstitute it at the point of sale, thus lowering distribution cost. An obvious method of removing water was to freeze the beer, thus removing pure water as ice. The beer flavour components remained in the beer in a more concentrated form. Much work was carried out but, for a number of reasons associated with capital and revenue costs and the lack of a market, as a production process the method looked doomed to fail. Then, in Canada, the Labatt Company provided a whole new angle to the process. Labatt realized there was a powerful market association with the concept of 'ice' beer and a new beer type was born. There was now a real market to drive product development. By the late 1990s most major brewers had produced their own ice brands and sales increased, backed by huge advertising spends. In 1997 in the USA alone over 32 million hl of ice beer was produced and volumes were increasing by 4% year on year. The rate of growth of production of these beers has slowed but nevertheless ice beer is now an important segment of the alcoholic drinks market.

The higher the original gravity of the beer the lower the temperature at which the beer freezes. The important point for ice beer is that the beer does not freeze homogeneously but as the temperature falls below 0°C , water separates as pure ice. Some compounds,

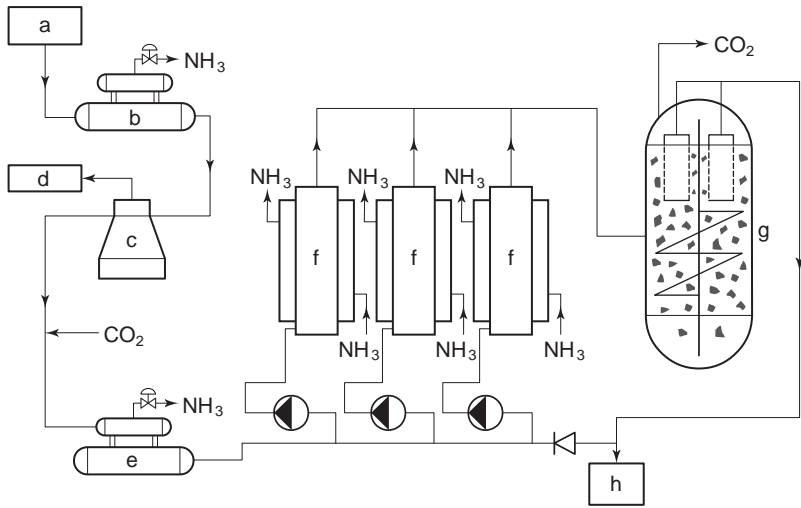

Fig. 15.18 Ice beer plant, Labatt/Niro; (a) route from fermentation, (b) dropping cooler, (c) centrifuge, (d) yeast, (e) beer cooler, (f) heat exchanger, (g) recrystallizer, (h) route to conditioning. (Kunze, 1999).

insoluble at low temperatures, such as some proteins and polyphenols also separate whilst alcohol and flavour volatiles concentrate. The key to a successful commercial process is to remove the ice as it is formed so it does not remain in one place and so restrict the process (as with casual ice bock production!). This is achieved by moving the beer during the cooling stage.

In the Labatt process (Fig. 15.18) fully fermented beer is cooled and then centrifuged to remove yeast. The beer is further cooled and then pumped through three heat exchangers to lower the temperature to -4°C (25°F). Small ice crystals form and the beer is then moved to the recrystallizer where the small crystals deposit on larger ones already present. The ice crystals can be filtered from the beer or removed in a hydrocyclone. A finite amount of ice is always retained in the recrystallizer. The beer of high alcohol content is held in a storage tank and adjusted to the required alcohol content with sterile, deaerated, carbonated water. The alcohol content of the processed beer is normally higher than the starting beer and the removal of polyphenols gives the beer a characteristically smooth full taste. It is this property that is appreciated by drinkers. The process is expensive and the success for the brewery depends on the market allowing the charging of a higher price for the product. Further developments in ice beers will depend on how the market develops and what prices can be sustained for the beers.

15.6.3 Diet beers

These are not strictly post-fermentation treatment beers but are discussed here to complete this section on special beer types. The basis of this type is a beer low in carbohydrate. A higher proportion of fermentable carbohydrate is therefore made available to the yeast than is the case in standard brewery fermentations. The resulting beers have a higher ethanol content but lower dextrin levels from a given original extract compared to normal beers. It should be noted that these beers seldom have lower calorific values than normal beers, merely lower carbohydrate contents. It follows that these beers are usually derived from fermentations of 100% apparent attenuation. Mashing can be adjusted by extending the

time and by a low temperature stand at 50 °C (122 °F) for at least 30 minutes but attenuation limits of more than 90% are seldom produced. Enzymes must therefore be added to the fermenter to degrade residual dextrins during fermentation and this can be in the form of malt flour or diastatic malt extract. The β -amylase, α -amylase, and limit dextrinase so added results in the degradation of dextrin in the fermenting wort.

In some countries the addition of enzymes of fungal origin is permitted (glucoamylase and pullulanase). Beers produced using fungal enzymes tend to be more biologically and non-biologically stable. Fermentation of these highly fermentable worts yields beers of very high alcohol contents and virtually no residual carbohydrate. The beers can be diluted to the appropriate alcohol content for sale. Pasteurization must be effectively carried out if using malt enzymes, as almost certainly bacteria will be introduced into the wort from the malt flour.

Work at Brewing Research International in the UK in the mid 1990s (Baxter, 1995) resulted in the genetic modification of a brewing yeast strain to include a glucoamylase gene from a non-brewing yeast. This strain was approved for use and is used in-house for the production of low carbohydrate beers. But, as the result of general public disquiet about the use of genetic manipulation, there have been no commercial developments using this strain. There seems to be a continuing, if static, market for this type of beer particularly as it is often assumed (wrongly!) to be a less fattening beer.

Finally, the term 'light' beer is sometimes confused with diet beer. Light beers have no real generic definition but are merely beers of low-alcohol or low-sugar content. As a result what constitutes a light beer can vary enormously. Beers described as light beers can have alcoholic strengths of from 2.5 to 4.0% abv but usually have a dextrin content of about 1% and a calorific value of 25 to 30 kcal/100 ml. As such, if drunk as an alternative to normal beer, they may be less fattening.

15.7 Summary

The post-fermentation treatment of beer is critical in yielding a product that is fit for sale and meets the consumer's expectation of a quality drink. The aim has to be to delight the consumer so that he will return to the product and drink it again. Flavour, clarity and stability of beer are improved by the post-fermentation treatments that have been discussed. This is also the area of the whole brewing process where emphasis can be placed on the development of special beer types.

There is increasing interest in the manipulation of beer properties post-fermentation to produce different beer brands from essentially the same brewhouse and fermentation techniques. This can result in considerable saving in capital and revenue cost with fewer requirements to invest in expensive maturation storage. In this respect further development in immobilized yeast technology with its potential for accelerated flavour improvement and production of novel beers would seem to be worthwhile.

15.8 References

- AIVASIDIS, A., MANDREY, C., ELLIS, H. G. and KATZKE, M. (1991) *Proc. 23rd Congr Eur. Brew. Conv, Lisbon*, 569.
- ANDERSON, R. G., BRITES SANCHES, A., DEVREUX, A., DUE, J., HAMMOND, J., MARTIN, P. A., OLIVER-DAMEN, B. and SMITH, I. B. (2000) *Fermentation and Maturation Manual of Good Practice*, European Brewery Convention, Zoeterwoude, The Netherlands.

- ANDREWS, J. M. H. (1997) *Ferment*, **10**, 309.
- ANNESS, B. J. (1980) *J. Inst. Brewing*, **86**, 134.
- ATTENBOROUGH, M. W. (1988) *Ferment*, **1** (2), 40.
- BARNES, Z. C. (2001) Personal communication.
- BAXTER, E. D. (1995) *Ferment*, **8**, 307.
- BRENNER, M. W. (1980) *Tech. Quart. MBAA*, **17**, 185.
- BROWN, D. G. W., CLAPPERTON, J. F. and MEILGARD, M. C. (1978) *J. Amer. Soc. Brewing Chemists*, **36**, 73.
- BYRNE, H., MATHEWS, S., MADIGAN, D., KELLY, R. J., MCENROE, C. and HARMEY, D. (1999) *Proc. 7th Conv. Inst. Brew (Africa Section)*, Nairobi, 55.
- CHALMERS, S. and HAUGHNEY, H. (1998) *Proc. 25th Conv. Inst. Brew (Asia Pacific Section)*, Perth, 165.
- CHAPON, L. (1994) *Brewers' Guard*, **123** (12), 21.
- COORS, J. H. (1977) *The Practical Brewer*, Master Brewers' Association of the Americas. Madison, Wisconsin.
- DICKENSON, C. J. and ANDERSON, R. G. (1981) *Proc. 18th Congr. Eur. Brew. Conv., Copenhagen*, 413.
- ESNAULT, E. (1995) *Brewers' Guard*, **124** (1), 25.
- GARDNER, D. J. S. (1993) *Ferment*, **6**, 279.
- GOPAL, C., REHMANJI, M., MOLA, A., NARAYANAN, K., TRINH, T. and WHITTINGHAM, J. (1999) *Proc. 7th Conv. Inst. Brew. (Africa Section)*, Nairobi, 62.
- GOPAL, C. and REHMANJI, M. (2000) *Brewers' Guard*, **129** (5).
- GREEN, H., SHAW, R. and CANDY, E. (2000) *The Brewer*, **86**, 201.
- GUZMAN, J. E., MCKEOWN, I. P., GLEAVES, M., STEWART, G. G. and DOYLE, A. (1999) *Tech. Quart. MBAA*, **36**, 227.
- HANNEMAN, W. (1999) *Tech. Quart. MBAA*, **36**, 167.
- HARDING, J. A. A. (1977) *Brewers' Guard*, **106** (9), 90.
- HASIMOTO, N. (1973) *Ann. Rept. Res. Labs. Kirin Brew. Co.*, **16**, 1.
- HOUGH, J. S., BRIGGS, D. E., STEVENS, R. and YOUNG, T. W. (1982) *Malting and Brewing Science Volume 2*, 2nd Edition, Aspen, Gaithersburg, Maryland.
- JENDE-STRID, B. (1997) *Proc. 25th Congr. Eur. Brew. Conv. Maastricht*, 101.
- JEPSEN, S. (1991) *4th Meeting on the Industrial Applications of Enzymes*, Barcelona.
- KUNZE, W. (1999) *Technology Brewing and Malting*, Int. Edition, (Translated by Wainwright, T.) VLB, Berlin.
- LEACH, A. A. (1989) *Ferment*, **2**, 33.
- LEACH, A. A. and BARRETT, J. E. (1967) *J. Inst. Brewing*, **73**, 246.
- LONG, D. E. (1995) *Ferment*, **8**, 239.
- MARRIOTT, R. (1999) *Proc. 7th Conv. Inst. Brew. (Africa Section)*, Nairobi, 140.
- MCKEOWN, I. P. and EARL, G. J. (2000) *Brewers' Guard*, **129** (6).
- MCMURROUGH, I., MADIGAN, D., KELLY, R. and O'ROURKE, T. (1999) *Food Technology*, **53**, 58.
- MENSOUR, M. A., MARGARITIS, A., BRIENS, C. L., PILKINGTON, H. and RUSSELL, I. (1997) *J. Inst. Brewing*, **103**, 363.
- MIEDANER, H. (1978) *The Brewer*, **64** (2), 33.
- MULLER, R. (1990) *Ferment*, **3** (4), 224.
- MUSCHE, R. A. and DE PAUWE, C. (1999) *J. Inst. Brewing*, **105**, 386.
- NARZISS, L., WULFINGER, H., STICH, S. and LAIBLE, R. (1992) *Brauwelt*, **51/52**, 2650.
- NIEFIND, H. (1982) *Monatsschrift für Brauerei*, **35**, 90.
- OECHLSE, D., ASCHER, R. and FEIFEL, K. (2000) *Tech. Quart. MBAA*, **37**, 377.
- O'ROURKE, T. (2000) *Brewers' Guard*, **129** (2), 29.
- PAJUNEN, E. and JÄÄSKELÄINEN, K. (1993) *Proc. 24th Congr. Eur. Brew. Conv. Oslo*, 559.
- PAJUNEN, E., GRÖNQVIST, A. and RANTA, B. (1991) *Proc. 23rd Congr. Eur. Brew. Conv., Lisbon*, 361.
- PFISTERER, E. and STEWART, G. G. (1975) *Proc. 15th Congr. Eur. Brew. Conv., Nice*, 255.
- REGAN, J. (1990) *Ferment*, **3** (4), 235.
- SHIEL, P. (1999) *Proc. 7th Conv. Inst. Brew. Conv (Africa Section)*, Nairobi, 76.
- SCHUR, F. (1983) *Proc. 19th Congr. Eur. Brew. Conv., London*, 353.
- SIEBERT, K. J., TROUKHANOVA, N. V. and LYNN, P. Y. (1996) *J. Agric. Food Chem.*, **44**, 80.
- SOLE, S. M. (2000) *Ferment*, **13** (4), 25.
- STEWART, G. G., BRYCE, J. H., COOPER, D., MONAGAS, M. and YOUNIS, O. (1999) *Proc. 7th Conv. Inst. Brew (Africa Section)*, Nairobi, 100.
- THILERT, T. (1999), *Tech. Quart. MBAA*, **36**, 427.
- ZANGRANDO, T. and GIRINI, G. (1969) *Proc. 12th Congr. Eur. Brew. Conv., Interlaken*, 445.

16

Native African beers

16.1 Introduction

African beers almost certainly have ancient origins, and may have originated in Egypt or Mesopotamia, where beers were being made by at least 3500 BC, and probably much earlier (Briggs, 1998). The names given to African beers are often unacceptable or inexact. Thus beers brewed in southern Africa have been called Kaffir or Bantu beers (but elsewhere in Africa beers are made by peoples who are not Bantu). Another term is opaque beers but not all African beers are truly opaque (e.g. Nigerian 'otika') and, on the other hand, some European-style beers are at least turbid (wheat beers; some ales consumed with conditioning yeast in suspension) and others, such as stouts, are not transparent. The term 'sorghum beers' is inexact as sorghum (raw grain or malt) is sometimes wholly or largely replaced with maize or millets or wheat or barley, and indeed in some cases bananas or manioc (cassava) serve as starchy adjuncts. Bouza may be made with wheat, barley or millets. Native names are also confusing in that different names are used for similar products by different tribes and within one language group different names are used for different types or qualities of beers (Daiber and Taylor, 1995; Dendy, 1995; Haggblade and Holzapfel, 1989; Harris, 1997; Miracle, 1965; Novellie, 1966, 1968, 1977; Novellie and De Schaepdrijver, 1986; Peterson and Tressler, 1965; Schwarz, 1956). Among the best known of these names are utshwala (Zulu) and joala (Basuto).

Traditionally, beers are made by women brewers, as was the case in mediaeval Europe, and they may be consumed with some ceremony. However, in southern Africa, as urbanization occurred, men moved into towns as casual labour, leaving their womenfolk behind. To meet the demand for opaque beers commercial brewing began (around 1908–1910) in Bulawayo and Durban. Since then, in some periods, the rate of increase in production has risen at an astonishing rate. For example, in South Africa, at one stage production increased by 26% in one year and while in 1953/4 production was 20 million imp. gallons (0.909 million hl) in 1965/6 production was 120 million imp. gallons (5.46 million hl; Novellie, 1968). At the same time much larger volumes of beer were produced in homes and small-scale 'village' breweries. Estimates of more recent

opaque beer production in different countries are in millions of hectolitres/year (Harris, 1997). At first the industrialized production of these beers was not straightforward, and many difficulties were encountered. To overcome these problems the CSIR (the Council for Scientific and Industrial Research) in South Africa established, around 1953, a research organization to investigate the bases of malting sorghum and beer production. The publications from this group, and its successors, provide nearly all the available information on the science of opaque beer production. Industrial production is spreading into other countries (Harris, 1997). In many areas the traditional brewing methods differ significantly from those used in southern Africa, and no doubt many brewing methods have not been described. Brewing may occur in the home, for home consumption or for sale, or it may be produced in a factory. Factory brewing seems to be carried out by men, a change that parallels the historical move from home-based brewsters (women) to industrial brewers (men) in Europe.

16.1.1 An outline of the stages of production

Stages usually distinguished in the production of African beers are the selection of the raw materials, malting (usually sorghum or millets or, less usually, maize), grinding, souring, cooking (with adjuncts), mashing (or conversion), straining, fermentation, and packing, distribution and consumption. The souring fermentation stage produces a desired level of acidity, caused by lactic acid. The second fermentation produces (mainly) alcohol and carbon dioxide. The beers are consumed while they are warm and are still fermenting and effervescent and so their composition is continually altering. Because of the continuing production of carbon dioxide the beers are held in vented containers. If not consumed in a day or two they become flat, too acidic and poorly flavoured, at least partly because acetic acid accumulates, and they are rejected.

The short shelf-lives of African beers create many commercial production and distribution problems. There are major differences between African- and European-style beers. African beers are rarely or never flavoured by herbs (in contrast to hopped European-style beers), complete starch conversion is avoided, and brewing does not produce an excess of yeast. Indeed factory brewing is a net consumer of yeast. Then the beers are always consumed, with the yeast they contain, while still fermenting and they are mostly opaque because of suspended yeast, starch granules and small particles of cereal grains, which are maintained in suspension by the rising bubbles of carbon dioxide and the high viscosity of the beer. The high viscosity is caused by gelatinized but incompletely degraded starch. It seems that most drinkers are more concerned with the flavour and body of a beer than with the (changing) alcohol content. South African beers are described as being as refreshingly sour as yoghurt, with a characteristic fruity odour. Alcohol contents of 1–8% have been noted, but values of 2.5–4.5% seem to be usual. Colours vary from a pale buff to a pinkish-brown, or elsewhere may even have a reddish tinge. pH values may be 3.3–3.6, lactic acid contents about 0.26% and total solids are around 6%. However, there are wide variations in beer composition, particularly in home-brewed beers (Haggblade and Holzapfel, 1989; Harris, 1997; Novellie, 1966; Novellie and De Schaepdrijver, 1986).

16.1.2 Bouza

Bouza (bouzah, bowza, etc.) is a bread-beer, made in Egypt and the Sudan from wheat, barley or millets, using methods supposedly resembling those used by the ancient

Mesopotamians and Egyptians (Briggs, 1998; Morcos *et al.*, 1973). Coarsely ground grain, sometimes mixed with a little malt, is mixed with water and some leaven or some yeast in sourdough. After standing the dough is moulded into loaves, which are lightly cooked. About one-third more grain is malted and then, often after drying in the sun, the malt (green or dry) is ground up with water and lumps of the broken up loaves. The mixture begins to ferment, either spontaneously or after the addition of some older bouza. After a period of active fermentation the mixture is filtered, for example through a horsehair sieve. The introduction of air at this stage checks the fermentation, but this is soon resumed. The drink is thick and yeasty, pale yellow, acidic and with a characteristic odour. The pH may be 3.5–4 and the alcohol content 4–5.5 g/100g. It must be consumed quickly, before deterioration begins (Briggs, 1998).

16.1.3 Merissa

In the Sudan a beer called merissa is produced. It has been said that sometimes the women chew some of the grain and spit the mix into the mixture, so adding salivary α -amylase, which may accelerate starch degradation; others do not mention this practice. Dirar (1978) describes a complex scheme for making merissa. Some sorghum grain is malted, dried and ground to a flour. Raw sorghum grain is ground to a fine flour, which is divided into three equal lots, each of which is processed differently. The first lot is lightly cooked, 'half-cooked', to a grey powder. The second lot is well cooked to give a brown paste. These two solid materials are mixed on leaves and allowed to cool. The third portion is wetted with just enough water to moisten it, and is set aside for about 36 hours, when a spontaneous, mainly lactic fermentation occurs. The acidified dough is strongly cooked in a steel container with repeated mixing until it is dark brown, is extremely sour and has a pleasant caramel flavour. It is cooled to room temperature and mixed with about 5% malt flour, water and some good merissa. Fermentation is well established after 4–5 hours. This material is too acid to drink. Portions of the combined two-thirds cooked flour, mixed with malt flour, are added in increments to the, strongly fermenting, acid fraction, without stirring them together. After 8–10 hours. fermentation the mixture is filtered through cloth. The liquid is consumed while it is still fermenting. The solids removed by straining are fed to cattle. The product has a pH of about 4, and an alcohol content of about 5%.

16.1.4 Busaa and some other beers

Busaa, and similar drinks, are made in Kenya, Uganda and Tanzania ((Nout, 1980; O'Rourke, 2001). In making busaa maize grits are mixed with water and allowed to stand for 2–3 days, at about 25 °C (77 °F), for souring. Malted finger millet (*Eleusine coracana*) is prepared by steeping for 8–24 h, then germinating for 2–3 days, also at about 25 °C (77 °F), followed by drying in the sun for 1–2 days and coarsely grinding. The soured maize dough is cooked on steel sheets over a charcoal fire at 65–75 °C (149–167 °F) for three hours. The cooled maize soured material is broken into lumps and one part is mixed with 1.5 parts of water and 0.1 part of malt flour. The main fermentation proceeds for 2–4 days. The mixture is then strained and consumed within one day, as it deteriorates rapidly and the increasing acidity (sometimes approaching 2% lactic acid) is unpleasant and causes the suspended solids to precipitate. When consumed beers may contain 0.5–1% lactic acid and 2–4% (v/v) alcohol.

Investigations into this process indicate that temperature control and the use of pure cultures of *Lactobacilli* and yeast could be used to advantage in the souring and

fermentation stages, giving more stable products that could be kept longer if preserved by end-fermentation or pasteurization in bottle. The latter was preferred. Beers made by related processes include ajou (Uganda) and mbweje (Tanzania) (O'Rourke, 2001). In the former a paste of ground millet and water is soured by burying bags of it in the ground for 5–7 days. In the latter bananas are used as starchy adjuncts. In the foregoing examples some materials are well-cooked, giving the possibility of adjusting the flavours of the beers by varying the intensity of the cooking. This is not so in subsequent examples, where water-grain mixtures are only boiled.

The preparation methods of other African beers have been described, otika from sorghum (Ogundiwin, 1977), pito from maize or sorghum (Ekundayo, 1969), oyokpo from millet (*Pennisetum typhoideum*; Iwuagwu and Izuagbe, 1985) and burukutu, also from sorghum (Faparusi, 1970; Faparusi *et al.*, 1973) all in Nigeria. The preparation methods for sorghum beers in the Cameroons and Togo have also been described (Chevassus-Agnes *et al.*, 1976; Perisse *et al.*, 1959). However, most information is available for the brewing methods used in southern Africa.

16.1.5 Southern African beers

A reliable method of brewing, in use by the Zulus in 1907 (quoted by Fox, 1938) used sorghum for preference, but millets and/or maize might also be used. The process required considerable skill. Grain sewn into sacks was steeped in running water for 1–2 days (sorghum) or up to 4 days (maize), longer periods being used when the weather was cool. Grain was sprouted, still in the sack or in a pot, for 2–5 days, maize taking longer, until shoot growth was judged adequate (1.9 cm, (0.75 in.), for sorghum, 1.3 cm, (0.5 in.), for maize). Usually the malt was dried in the sun or inside a hut, but sometimes it was used undried. Initially unground grain or (better) a 50:50 mixture of grain and malt was soaked in water for a day. After draining the wet grain was finely ground to a paste, between stones, in the morning and the dough was moulded into lumps. In the afternoon the paste was just covered with boiling water in a pot and cold water was added to adjust the temperature according to the brewster's judgement. As the mixture slowly cooled so spontaneous acidification occurred. Next day the water was collected from above the dough and was boiled with more water while the dough itself was mixed with fresh boiling water and was mixed to a thin porridge which was added to the boiling water. After the boil, of 20–40 minutes, (longer periods being needed for maize), the mixture had thickened because the starch present had gelatinized. The mixture was too thick to pour from a spoon. Most of the mixture was allowed to cool quite slowly, but a small amount was cooled quickly and was mixed with ground malt, when starch conversion and a spontaneous fermentation began, creating a 'starter culture'. When the main mash was cool enough more ground malt, in an amount exceeding the initial amount of grain by about 25%, was mixed in, together with the fermenting 'starter culture', initiating a rapid onset of fermentation. When fermentation was vigorous the mixture was strained through a woven grass strainer. The filtered liquid continued to ferment while the strainings were reserved for making a 'small beer'. Fermentation went on for 1–2 more days before the beer was consumed. Beyond this period the product spoils. Analyses of these beers gave estimates of solids contents of 5–13%, alcohol contents of 0.5–8.0% (v/v; usually 4% when fresh), crude protein contents of 0.7–1% and mineral salts contents of 0.18–0.36%. Others reported solids contents of up to 20%. These beers were regarded as foods, which constituted most or all of men's diets in some seasons, and were an alternative to porridges or acidified porridges which were made without the second, alcoholic fermentation.

Other, less complicated methods have been quoted (Haggeblade and Holzapfel, 1989; Novellie and De Schaeppdrijver, 1986). For example, maize broken up by pounding is mixed with boiling water and is left for a day, when a spontaneous lactic fermentation occurs. More water is added, the mixture is boiled for 2–3 h, and is left to cool. When cool a roughly equal amount of pounded sorghum malt is mixed into the soured maize adjunct mixture. After a fermentation period of 24 h the mixture is strained and is ready for consumption. In a ‘generalized’ scheme for home or small-scale brewing for sale malted sorghum, or less usually malted pearl millet (*Pennisetum typhoides*) or finger millet (*Eleusine coracana*) is broken up using a mortar and pestle, or by grinding between stones or is pulverized in a hammer mill. In southern Africa commercially prepared and ground sorghum malt may be purchased. For souring some of the malt is mixed with water and is heated for 30–90 minutes. Heating may be in traditional clay pots, or in iron or steel containers. The mixture is allowed to cool overnight, when a spontaneous lactic acid fermentation begins, and the mixture is soured. Next day the sour is mixed with more water and ground sorghum, sorghum malt, maize or maize grits. The mixture is cooked by bringing it to the boil and boiling for 2–7 h. The mixture is cooled overnight, sometimes by dividing it between several shallow dishes. During this time the mixture thickens as the gelatinized starch tends to set. In the morning mashing and fermentation begin when more malt flour is mixed in, sometimes together with some good beer, which provides an inoculum of yeasts and other microbes. This stage may be carried out in wooden, metal, clay or plastic containers. After about two days fermentation the beer is strained to remove coarse particles by passing it through a woven-grass, bag-like container (which may be squeezed to recover more liquid) or a metal screen. When fermentation has resumed the beer is ready for consumption.

16.2 Malting sorghum and millets

In southern Africa sorghum malts are preferred but elsewhere in Africa malts may also be made from various millets (Briggs, 1998; Haggeblade and Holzapfel, 1989; Miracle, 1965; Nout and Davies, 1982; Novellie, 1968; Novellie and De Schaeppdrijver, 1986; Nzalibe and Nwasike, 1995). All these plants belong to the grass family. Technically the grains are caryopses, fruits in which the ovary wall remains investing the seed as the pericarp. It seems that maize is malted only as a last resort. In ‘home’ brewing the chosen grain is steeped sewn into rush bags, sacks or held in baskets, in running water, or in pots, jars, tubs, gourds, calabashes or other vessels, in still water. Steeping times vary from 1–3 days. The grain is drained and placed in jars or baskets lined with leaves or on mats, and is covered with leaves and left to germinate. From time to time it is watered. When growth is far enough advanced, in 2–6 days, the grain is usually dried in the sun before use, although sometimes the malt is used undried. It is used with the roots and shoots still attached. All the grain species occur in many varieties of widely differing malting qualities and characters. Sorghums with grains having thousand corn dry weights (TCW) of 7–61 g are known, but values of 10–38 g are more usual, these grains having dimensions of 3–5 mm (0.118–0.197 in.) by 2–5 mm (0.079–0.197 in.). Sorghum varieties vary greatly in their malting qualities.

Maize grains are larger, for example dent corn may have TCWs of 150–300 g and be 12 mm by 8 mm by 4 mm (0.472 by 0.315 by 0.157 in.). This grain was introduced into Africa, perhaps in the 16th century, and grains, or materials made from them, are common brewing adjuncts. The various millets have much smaller grains. This creates

problems for 'industrial' maltsters. Like sorghum, millets have many different names (Briggs, 1998). Pearl millet (*Pennisetum typhoides*) has the largest grains (TCW 5–10 g; 3–4 mm, 0.118–0.157 in., length). Finger millet (*Eleusine coracana*) is frequently malted. Common millet (*Panicum miliaceum*) grains are about 3mm (0.118 in.) long and have a TCW of about 6 g. Acha, or fonio (*Digitaria exilis*) grains have a TCW of only 0.65 g.

In southern Africa, the first industrial malting of sorghum followed village practices and to some extent this is still the case (Daiber and Taylor, 1995; Haggblade and Holzappel, 1989). Grain is steeped for about 16–18 h in concrete tanks, metal drums or barrels, and then, after draining, is spread out, in the open, on slightly sloping concrete floors in beds 13–90 cm (5.12–35.4 in.) thick. Here it is covered with wet sacks. At intervals the grain is unevenly wetted by hosing, and it may be turned by hand. In warm weather the grain is spread more thinly and in cold weather the bed is thickened to favour heat loss and heat retention respectively. Evidently temperature control is inadequate, as is regulation of the wetting, 'sprinkling'. Growth is very irregular, the grain at the top of the bed being poorly grown, while that at the base, on the floor, is overgrown. When growth is judged to be sufficient the sacks are removed and the grain is spread more thinly to dry in the sun. This process is used to make malt that is sold after grinding and makes a very irregular product. It often carries a high load of microbes. Apart from sometimes covering the floors with roofs, but with no side walls, and sometimes using steepers containing formaldehyde (see below) this form of malting seems to have advanced very little.

Malting for the larger breweries is carried out indoors, under more controlled and hygienic conditions. The grain is thoroughly cleaned before use and may be washed. Malting plant is regularly cleaned. Steeping, for 16–24 h (or even as little as 6 h), is usually carried out in tanks that may be aerated. The moisture content finally achieved is about 35%. To control microbes the grain may initially be steeped in a solution of formaldehyde or sodium hypochlorite (an agent that taints barley malts, giving them an 'antiseptic' flavour). The formaldehyde treatment was originally adopted to deal with high-tannin, birdproof sorghums that are so rich in tannins they inactivate and insolubilize the malt enzymes during mashing and inhibit the souring process, so blocking brewing. For the first four hours of steeping, the grain is immersed in a solution of formaldehyde (0.02–0.08%, depending on the tannin content of the particular grain), then it is thoroughly rinsed and steeping is completed in fresh water (Daiber, 1975; 1978). Recent studies indicate that steeping for longer periods of up to 40 h at 25–30 °C (77–86 °F), with air-rests, gives superior malts (Dewar *et al.*, 1997a,b). Evidently there would be advantages to using temperature-controlled steepers, equipped for carbon dioxide extraction, during air-rest periods.

Germination is carried out in modified Saladin boxes. The grain bed, which may be 1.5 m (4.92 ft.) deep, rests on a perforated base through which temperature-controlled and humidified air can be blown to cool the grain. Because the grain grows so vigorously the airflow must be larger than that used for barley, around 1,000–1,200 m³/h/tonne grain. Because of the extensive embryo growth the volume of the grain bed increases greatly during germination. The grain should be at 24–30 °C (75.2–86 °F). Turning may be mechanical but, because the seedlings are so easily damaged, it may be carried out better by hand, the grain being shovelled from one compartment to the next. During turning the grain may be also sprinkled with water as required. After 5–7 days, or 4–6 days under ideal conditions, the malt is dried by blowing warm air, at 50–60 °C (122–140 °F), up through the grain. The temperature is kept low to minimize the destruction of enzymes, and avoiding transfer to a kiln avoids damage to the green malt. Experience with barley

suggests that a lower initial drying-air temperature (40°C; 104°F) would be beneficial for enzyme survival.

The main objectives of malting sorghum are to generate the enzymes needed for mashing and to supply sufficient soluble nitrogen to support the *Lactobacilli* during souring and the yeast during the fermentations. Sometimes sugar levels are also considered. Although it is sometimes measured, the yield of extract is largely ignored. This is because most of the extracted materials in sorghum beers are derived from the adjunct(s) used. Malting losses, with seedling roots and shoots retained with the malt, are 10–20% dry basis (Daiber and Taylor, 1995), but using some conditions they are very much higher (particularly if the seedling tissues are discarded, as is the case for malts intended for making lager beers), and so the maltster must strike a balance between malt quality and losses.

The criteria that must be met are the level of diastatic power (DP), the free amino nitrogen (FAN), and a low tannin level (Daiber and Taylor, 1995; Daiber *et al.*, 1973). In addition the beer should not have an appreciable level of mycotoxins or cyanide from the malt. Sorghum seedlings generate the cyanogenic glycoside dhurrin, which is enzymically degraded to glucose, *p*-hydroxybenzaldehyde and hydrogen cyanide (prussic acid). Toxic levels of prussic acid precursor occur in sorghum seedlings and some baking and steaming processes reduce this to low levels (Dada and Dendy, 1987). When sorghum was germinated for six days at three different temperatures the cyanide contents of the shoots increased continually to six days, to 614 ppm, at 25°C (77°F), peaked after two days germination at 666 ppm, at 30°C (86°F), and fell after two days at 35°C (95°F), when it was 385 ppm (Panasiuk and Bills, 1984). However, for reasons that are not clear, toxic levels of prussic acid do not appear in sorghum beers (Glennie, 1983).

The grain chosen for malting must be of an acceptable variety, be clean and undamaged and germinate well, usually at least 92–95%. As sorghum germinates the DP rises from a negligible value as both α - and β -amylases are synthesized in the embryo. There are variations, but generally 60–70% of the DP is due to the former enzyme. This contrasts with the situation found in barley malts, in which the DP is higher and the β -amylase activity is relatively much higher (50–80% of the DP), and it exists preformed in the starchy endosperm (Briggs, 1998). There are problems in extracting the enzymes from some sorghum malts, due to the presence of tannins, and often 2% peptone is included in the extraction medium when DP is to be determined. α -Glucosidase (maltase) is insoluble but active. Its importance in brewing is unclear and its activity is not determined on a routine basis. Its pH optimum is unusually acidic, pH 3.8 (Taylor and Dewar, 1994) and so it is likely to act in mashing and produce the relatively high levels of glucose found in the worts.

The DP levels of sorghum malts (20–60 SDU/g malt) are low compared to those of barley malts (150–200 SDU/g malt). The units of activity used, sorghum diastatic units (previously KDUs), are small and 1 SDU approximately equals 0.5°L. Many malts were and are produced with too low DP activities, often caused by growing the grain at too low temperatures. Commercial brewers now specify minimum DP values in malts, (often 28–33 SDU/g). Higher levels of enzymes and FAN in malts are obtained by malting high-nitrogen grain and choosing smaller grains, which contain larger proportions of embryo tissues. In sorghum all the diastase is synthesized in the embryo, and apparently there is no contribution from the aleurone layer. Sorghum grains, unlike barley, wheat and some millets, do not respond to added gibberellic acid to any appreciable extent.

The level of FAN in sorghum malt is important because this represents the nitrogen-containing nutrients needed by the microbes (Pickerell, 1986). The largest part of the

FAN is from the shoots and roots, which are ground up together with the rest of the grain, before mashing. FAN levels, like DP, increase with malting time. During malting proteolytic activity increases relatively little and this enzymic activity is poorly extractable but carboxypeptidase activity, which is concentrated in the embryo, increases substantially (Dewar *et al.*, 1997c,d; Dewar and Taylor, 1995; Taylor, 1991). Both enzymic activities have acidic pH optima.

The structure of the sorghum grain alters, i.e., undergoes modification, during malting but the cell walls of the endosperm appear to remain largely intact, while losing their physical strength. Modification can be assessed by measuring the porosity or compressibility of the grain (which both decline as modification proceeds) or, most simply, by measuring its specific gravity, which also declines (Daiber *et al.*, 1973). These characteristics are not determined routinely.

Relatively few studies have been reported aimed at optimizing sorghum malting for the production of African opaque beers. Other studies have been directed towards making sorghum malts for brewing clear, lager-type beers (Briggs, 1998). The variables that have been studied are steeping duration and temperature, the degree of sprinkling during germination, the temperature and duration of germination. The malt characteristics investigated have been the DP, FAN, hot water extract (total soluble solids) and malting loss. Extracts have been determined in various ways, e.g., after mashing for two hours at 60°C (140°F). Values obtained after mashing at 45°C and then 70°C (113 and 158°F) are higher (Daiber and Taylor, 1995). In connection with brewing opaque beers malting losses are determined with the seedling tissues retained with the malt, so the losses encountered are mainly respiratory losses with a little due to leaching losses incurred during steeping.

Early experiments indicated that malting temperatures of 20°C (68°F), or less, were much too low for maximum development of DP (Novellie, 1966). Systematic studies confirmed various other results, e.g. that for grain steeped and grown at about 30°C (86°F), 18 hours was the optimum steeping time and 4–5 days the best germination period for malting (Pathirana *et al.*, 1983). In a study with germination times of up to six days, at temperatures of 24–36°C (75.2–96.8°F), with fixed initial steeping conditions but three levels of watering during germination, it was found that at steep out the moisture content was 33.7%, and after six days germination the moisture contents of the low, medium and highly wetted samples were 42.8%, 60.8% and 77% respectively (Morrall *et al.*, 1986). Entire malt was used in this study and total soluble solids ('extract') were determined with two-hour mashes at 60°C (140°F), conditions which approximate to those used in mashing when making opaque beer. DP increased rapidly during the first four days of germination, the highest yield of 46.6 SDU/g being obtained after five days germination, at 24°C (75.2°F) in the medium-wetted grain, but 28°C (82.4°F) gave nearly as good results. At this stage the malting loss was 9.9%, the FAN was 129 mg/100 g malt and the total soluble solids value was 73.5%.

At higher temperatures DP values were lower and under a number of conditions DP values peaked and then declined, as also happens in malting millets and wet-grown barley (Briggs, 1998). All the variables influenced FAN, which increased with increasing moisture content and germination time. The maximum level reached was 180 mg FAN/100 g malt, after six days germination, at the highest moisture content, in grain grown at 32°C (89.6°F), when the malting loss was about 20%, the DP was 38 and the total soluble solids value was 66.1%. The maximum level of total soluble solids, 75.5%, was obtained from grain grown for six days at 24°C (75.2°F), with a medium moisture content, when the malting loss was 13.6%, the DP was 46.3 and the FAN was 148 mg/100 g malt.

Malting losses (seedling tissues retained with the malt) increased with germination time and increasing moisture content but were relatively little influenced by germination temperature.

Clearly, strict control of malting conditions is necessary to produce malt in the best possible yield, with the desired specifications. Usually it will be necessary to compromise since, for example, conditions chosen to give maximum levels of FAN are associated with high malting losses and low DP values. Air-rests are beneficial when warm water steeping is tested (Ezeogu and Okolo, 1994, 1995). Further studies indicate that with steep aeration or air-rests longer steeping times, up to around 40 hours, are better than the usual shorter times found by earlier investigators (Dewar *et al.*, 1997 a, b, c). Malt DP increased with steeping temperature up to 30 °C (86 °F), and of the temperatures tested, FAN and extract peaked at a steeping temperature of 25 °C (77 °F). Aeration increased the yields of extract and FAN. Using optimized steeping conditions, with air-rests, and two different wetting schedules, it was found that generally the optimum germination temperature was between 25 and 30 °C (77 and 86 °F). The roots and shoots contributed up to 61% of the whole malt FAN. In the winter, in South Africa, temperatures can fall below 18 °C (64.4 °F). It was concluded that much sorghum malt is made under seriously sub-optimal conditions.

Ways have been sought for reducing the losses of dry matter that occur when sorghum is malted. Applications of potassium bromate and ammonia have not been beneficial, and warm-water steeping, at 40 °C (104 °F), have given equivocal results, which varied with different grain samples (Ezeogu and Okolo, 1994, 1995). When dilute alkaline steeps (0.1% sodium hydroxide) were tested, probably with the initial object of extracting unwanted tannins, the moisture content and quality of the malts obtained were increased, even when low-tannin grains were treated (Dewar *et al.*, 1997a, 1999; Ezeogu and Okolo, 1999; Okolo and Ezeogu, 1996). However, there were varietal differences in responses to alkaline steeping.

While various millets are malted in villages it seems unlikely that they are now malted commercially. The small sizes of the grains make them inconvenient to handle and, in pneumatic malting plants, they tend to block the slots of the false floor and form dense layers that obstruct the passage of conditioning air. However, in the past millets were malted mixed with sorghum, which gave a more open bed of grain. It was believed that a more favourable mixture of enzymes was obtained from the mixture. Unlike sorghum, some millets respond to external doses of gibberellic acid. The studies carried out on the malting of millets have been in connection with the preparation of foodstuffs (Briggs, 1998).

16.3 Brewing African beers on an industrial scale

The first attempts at brewing African beers on an industrial scale were made in southern Africa, using primitive equipment and without fully understanding the principles involved (e.g. Novellie, 1968; Oxford, 1926; Schwartz, 1956; Young, 1949). The failure rate was high. There have been great improvements in both understanding and brewery performance since the early years, and industrial scale brewing is spreading to other countries (Harris, 1997). Milled malts and adjuncts (maize grits, whole maize meal, degermed sorghum grits, or whole sorghum), may be delivered directly to the brewery. Of the several brewing systems in use the most common in South Africa is the Reef Process (Daiber and Taylor, 1995; Haggblade and Holzapfel, 1989; Harris, 1997; Novellie and De

Schaepdrijver, 1986). In one version of this process milled sorghum malt (0.28 t; 617.3 lb.) is slurried with water (25 hl; 550 imp. gal.) and is held at 48–50 °C (118.4–122 °F) for 8–18 hours. Older ‘sour’, kept under conditions that maintain the lactic acid bacteria in a rapid, logarithmic state of growth, is mixed in to seed the mixture with thermophilic *Lactobacilli*. The process is stopped when the pH falls to 3.3 or less and the lactic acid concentration is about 0.8%.

During this process some amylolysis and proteolysis occur, with increases in sugars and FAN. Alternatively, outside South Africa, commercially prepared lactic acid may be used to provide acidity. In the next stage, cooking, the sour is mixed with maize grits or a sorghum adjunct (2.3 t; 5,071 lb.) and water (168 hl; 3,696 imp. gal.) and the mixture, at pH 3.6–4.0, (depending on the product), is boiled for two hours at atmospheric pressure or for shorter times under pressure at temperatures up to 110 °C (230 °F). During the subsequent cooling a little malt may be added, at a temperature of about 80 °C (176 °F), to thin the material, by beginning to liquefy the starch so that transfer is easier. Water (13 hl; 286 imp. gal.) and ground malt (0.62 t; 1,367 lb.) is mixed in and conversion takes place in this cooled, acidic mash, which is continued at 60 °C (140 °F) for two hours, at a pH of 3.6–3.8. Under these conditions the granular maize and sorghum starch does not gelatinize and the activities of the amylases are limited by the low pH so sugar production is limited. Proteolysis occurs and the level of FAN increases to a useful extent. The thinned mash is then ‘strained’, at 60 °C (140 °F), either through a screen, or by centrifugation followed by passage through a vibrating screen. The collected strainings weigh about 3 t, 6,614 lb., and contain about 1.008 t, 2,222 lb., of dry material, which represents about 30% of the grist solids. The screenings are sold, wet or after drying, for cattle food. This wasteful process has proved difficult to improve. Although it is possible to re-mash the screenings with added enzymes to obtain a secondary wort, this finding seems not to have been exploited. The objective of straining is to remove coarse particles of more than about 0.25 mm (about 0.01 in.) width.

After straining the ‘wort’, about 200 hl, 4,399 imp. gal., cooled to 28–30 °C (82.4–86 °F), is transferred to a stainless steel fermenter of 150 or 270 hl (3,300 or 5,939 imp. gal.) capacity, and is pitched with a selected, pure, dried culture yeast (5.5 kg; 12.1 lb.). At this stage the wort contains 6–7% fermentable sugars (glucose, maltose and maltotriose in the approximate ratio 1:3:1), 3% soluble dextrans, more than 1% of gelatinized starch and about 2% ungelatinized starch. The optimal conditions for proteolysis are 51 °C (123.8 °F) and pH 4.6, and so it is not surprising that FAN increases during mashing. At the end of the mash about 30% of the FAN was generated during mashing, the other 70% being from the malt and having been generated during souring. As malts are prepared with higher DP values the ratio of adjunct to malt tends to increase, carrying with it the risk that the mash will contain too little FAN to adequately support the yeast growth during fermentation. Perhaps 100 mg FAN/litre is the minimum safe concentration, when the FAN is derived from sorghum malt. Fermentation proceeds for a selected time (usually 8–24 h), then the actively fermenting beer is sold either on draught or in small waxed cardboard or larger polyethylene containers. All containers are vented to allow the escape of the continuously generated carbon dioxide. Unfortunately this is apt to allow beer to escape as well.

Compared to ‘clear beers’ opaque beers are viscous (e.g. 15 mPa.s) and are rich in fusel oils. Other analyses of commercial South African beers (ranges, with the mean values in brackets) are: alcohol, 2.4–4.0% w/w (3%), total solids 2.6–7.2%, w/w (4.9); insoluble solids, 1.6–4.3% (2.3); lactic acid, 164–250 mg% (213); pH 3.2–3.9 (3.5); volatile acids as acetic acid g/100ml, 0.012–0.029 (0.026), total nitrogen 0.065–0.115%

(0.084) (Novellie, 1968; Novellie and De Schaepdrijver, 1986). Other reported values differ significantly. Part of the art in this brewing system is to produce the desired levels of nutrients for the lactic acid bacteria and the yeast, to gelatinize some of the starch, but not to degrade the starch so much that the beer is 'thin'. The residual starch is relatively poor in amylose and the side chains of the amylopectin are roughly halved in length (Glennie, 1988).

The iJuba process gives a less viscous beer, which is made to meet the preferences of the Zulu people. Starch conversion is carried further in this process. Water (165 hl; 3,630 imp. gal.), maize grits (1.275 t; 2,811 lb.), ground sorghum grain (0.795 t; 1,753 lb.) and sorghum malt ('pre-malt'; 0.105 t; 232 lb.), or a microbial amylase, are combined and the mixture is heated and finally boiled, for two hours, at its natural pH, when enzyme activity ceases, starch is gelatinized and microbes are almost all destroyed. The pre-malt or microbial amylase is added to liquefy some of the starch and reduce subsequent handling problems. The mix is cooled, to 60 °C (140 °F), and sorghum malt (1.1 t; 2,425 lb.) is added and, after two hours conversion, which occurs more rapidly than in the Reef process, at this 'natural' pH, water is added and the mash is allowed to sour for around four hours at 50 °C (122 °F) to a pH of 3.8–4. The souring may be initiated by the addition of a pure culture of *Lactobacillus delbrückii* (*leichmannii*) or part of a previous sour. A small amount of ground malt (0.105 t; 232 lb) is then added and the mixture is heated to boiling, when the lactic acid bacteria are killed and all enzyme activity is terminated. Following this heat treatment the mixture is cooled to 40 °C (104 °F), more sorghum malt (0.105 t; 232 lb.) is added, and the mixture is strained and cooled to 28 °C (82.4 °F). Strainings amount to 2.5 t, 5,512 lb., less than in the Reef process because starch liquefaction is more advanced and so the viscosity of the mixture is less, allowing a 'cleaner' separation of the coarser materials. Active dried yeast (3.5 kg; 7.72 lb.) is added to the wort (about 200 hl; 4,400 imp. gal.) and fermentation proceeds for 8–48 h, at 28 °C (82.4 °F), before the fermenting beer is packaged and distributed. In contrast to the Reef process the amylases convert the mash at the natural pH, when they are much more active than in the acid conditions used in the Reef process mash. In addition the heat treatment effectively sterilizes the mash before the last malt addition, straining and pitching.

The Kimberley style of brewing is intermediate between the Reef and the iJuba styles, and was developed to allow brewing with poor-quality sorghum malts with low DP values. The first stages involve two process streams. In the 'sour stream' sorghum malt (0.9 t; 1,984 lb.) is mixed with water (25 hl; 550 imp. gal.) and the mixture is held at about 49 °C (120.2 °F) for 18 h, when the pH falls to 3.2. The microbes are then killed, and enzymes are inactivated, by heating the sour to 85 °C (185 °F). In the 'main' process stream maize grits (2.3 t; 5,071 lb.) and water (168 hl; 3,696 imp. gal.) are mixed and sometimes some microbial α -amylase is added to 'thin' the starch as it gelatinizes. The mixture is then boiled for two hours, at its natural pH. The cooked material is mixed with water (13 hl; 286 imp. gal.) and ground sorghum malt (0.62 t; 1,367 lb.), and conversion proceeds for 2 h at 60 °C (140 °F) at the 'natural' pH, 5.8–6.0. After mixing in the heated sour from the other process stream, when the fall in pH checks the activities of the amylases, the mixture is strained, yielding 3 t, 6,614 lb., of strainings, and the wort is pitched with 5.5 kg, 12.1 lb., of dried yeast. Fermentation and distribution are carried out in the usual ways.

While the three processes described, including minor variations of them, are the most usual others are also used (Diefenbach, 1996; Harris, 1997). In some of these processes 'sour' are replaced with lactic acid. In the split sour Chibuku process maize and sorghum

grits are cooked together with some of a sorghum malt sour (about 40%), and more sour (60%) is added after a conversion stage, which is carried out on the cooked material after the addition of sorghum malt and more water. After heating to 80 °C (176 °F), at pH 3.7, the material is subjected to a second conversion stage, with added fungal amyloglucosidase, for 30 minutes at 60 °C (140 °F). The amyloglucosidase degrades starch and dextrins to glucose. The next stages are straining, cooling and fermentation.

A predictable problem is continuing activity of the amyloglucosidase in the beer. In the Chibuku Zimbabwe/Botswana process α -amylase and lactic acid are added to the maize and water cook and amyloglucosidase and sorghum malt are used in a second conversion stage, the enzymes needed in the first stage being provided by sorghum malt. So in this process milled maize (1.8 t; 3,968 lb.) is mixed with water (95 hl; 2,090 imp. gal.), lactic acid (8 litres; 1.76 imp. gal., 80%), and amylase. After a boil for 1.5 h at pH 5.0, water (60 hl; 1,320 imp. gal.) is added and sorghum malt (0.46 t; 1,014 lb.) is added to the cooled mixture and conversion takes place for two hours, at 60 °C (140 °F) and pH 5.5. After centrifugal straining the wort is pasteurized by heating to 80 °C (176 °F). The mixture is cooled to 60 °C (140 °F) and is incubated with amyloglucosidase and more sorghum malt (0.02 t; 44.1 lb.) for 0.5 h. Following this second conversion the wort is cooled and pitching and fermentation are carried out, at 26 °C (78.8 °F). In the Chibuku/Zimbabwe/Malawi process malt is not used at all. Extract is derived exclusively from milled maize. Acidity is provided by lactic acid and the enzymes employed are microbial α -amylase and amyloglucosidase. The product, by usual criteria, is not a beer but a beer substitute (Harris, 1997).

Comparisons between 'home' and industrial opaque beer brewing practices and between these and the methods used in making 'clear beers' are interesting, but opaque beer home brewing does not seem to have been studied scientifically. Obvious differences are the scales of operation and the near total lack of control, other than the brewster's judgement, in home brewing. Industrial brewers have better raw materials of more uniform quality so, for example, they specify that malts should have DPs of 28–35 SDUs and water contents of less than 10%. The more exact temperature control available in industrial breweries has advantages at every stage of operation. The souring process is under better control, both because by operating at around 50 °C (122 °F) only thermophilic bacteria are encouraged to grow, and inoculation may be with a pure culture of a *Lactobacillus*, and because pH and acidity can be measured. Not all thermophilic bacteria are desirable in the sour. In home brewing the souring occurs in a cooling environment, so many different bacteria may grow, thermophiles being succeeded by mesophiles, with the generation of less lactic acid and the formation of unwanted flavours and aromas.

In home brewing the souring and alcoholic fermentations are not clearly separated, rather they overlap. The lactic acid is said to help the softening of the endosperm during cooking, so facilitating the release and gelatinization of the starch granules. Final beers should contain both gelatinized starch and ungelatinized granules. Starch gelatinization temperature ranges are maize, 62–74 °C (143.5–165.2 °F), sorghum, 69–75 °C (156.2–167 °F), millets, 54–85 °C (129.2–176 °F) and barley, 60–62 °C (140–143.6 °F) (Briggs, 1998). Consequently in mashes carried out at 60 °C (140 °F), the sorghum amylases will not attack granular sorghum, millet or maize starches to any appreciable extent. In several of the mashing processes the acidic pH values (pH 3.6–4.0) limit the activities of the sorghum amylases (α -amylase optimum pH 4.5–5; β -amylase optimum 5.2–5.5; Daiber and Taylor, 1995), acting on the gelatinized starch. As with all α -amylases, calcium ions form an integral part of the sorghum enzyme and inclusion of calcium salts in the

mashing liquor stabilizes the enzyme and enhances its activity, as is the case with the barley enzyme during mashes for making clear beers (Taylor, 1989, 1992).

Commercially, the alcoholic fermentation is initiated by pitching with pure, top fermenting yeast, rather than the mixture of microbes present on the sorghum malt and brewing vessels used in home brewing, which give unpredictable fermentations. Even so, industrial fermentations contain microbes from the raw materials and these are major contributors to spoilage. During the alcoholic fermentation acidification continues and so the pH continues to fall. Hetero-fermentative, mesophilic bacteria produce some lactic acid and also a range of other products, with adverse effects on flavour. As fermentation slackens, and the generation of carbon dioxide declines, air gains more ready access to the liquid, oxidative changes can occur and some alcohol is oxidized to acetic acid, which confers an unwanted, vinegary flavour and aroma. Yeast may die and autolyse, reducing the competition with, and supplying nutrients for, contaminating microbes. Some microbes may ultimately form a pellicle on the surface of the beer. Thus spoilage is inevitable in several days and this creates major problems for supplying beers over long distances and in meeting the variable demands for beer, which peak at weekends and at the ends of each calendar month.

16.4 Attempts to obtain stable African beers

The irregular and short shelf-lives of African beers, say three days in summer and five days in winter in South Africa, create problems of supply and distribution and ensure that breweries have excess brewing capacity for much of the time. This they must have to allow them to meet the high demands at weekends. In an older type of brewery the shelf-life of the product may be three days, while in a modern, scrupulously cleaned, dust controlled plant, using pure cultures of yeast and perhaps of *Lactobacilli*, the shelf-life may still be only five days. Various attempts have been made to produce stable beers but with only limited success. Experimentally, a stable form of Kenyan beer was prepared by pasteurization and a clear Nigerian beer, oyokpo, was stabilized with benzoic acid (Daiber and Taylor, 1995; Iwuagwu and Izuagbe, 1985; Nout, 1980). Most studies concern southern Africa (Harris, 1997; Haggblade and Holzzapfel, 1989; Novellie and De Schaepdrijver, 1986). Chilling the wort to 14–16 °C (57.2–60.8 °F) before pitching with yeast slows the fermentation, and lengthens the shelf-life of the beer. However, this approach has problems as the product is consumed warm by choice and refrigerated transport and dispensing equipment is not available. Storing under a top pressure of carbon dioxide has been proposed, but apparently this is not used. Heavily γ -irradiating the malt greatly reduces the population of microbes and increases the shelf-life of beer from about four to six days. Again, this process seems not to be used.

Successful ways around the instability problem involve the use of beer powders or concentrated worts. Techniques using pasteurization of worts or beers have not worked so well. Beer powders consist of dry, finely milled sorghum malt, dry yeast and pre-cooked maize meal. The cooking is by steam injection, which gelatinizes at least some of the starch. Some formulations may also contain some acidified material. 'Brewing' consists of dispersing the powder in warm water. Conversion, acidification (by bacteria from the malt) and alcoholic fermentation begin rapidly and simultaneously. The product is ready for consumption in 4–8 h and has a shelf-life of about one day. This process resembles the production of the millet beer, busaa (Nout, 1980). The beer is of poor quality. In part this is because initially the acidity is low, giving spoilage organisms a chance to multiply

before the pH falls. The powder is stable and so can easily be transported and stored, allowing beer to be produced in remote locations, at short notice and in small or large amounts. Another approach is to make wort, with a low solids content, in an approved fashion and then, after straining, concentrating it in a film evaporator to around 50% solids (Harris *et al.*, 1999). It is possible to spray-dry this material. The concentrated wort is syrupy and contains solids. It is relatively stable, even to spoilage by osmophilic yeasts. Because it is concentrated and stable it can be widely distributed relatively easily. To brew syrup, 5 kg (11 lb.), is diluted to 25 litres (5.5 imp. gal.) and is pitched with brewing yeast. The product can be a high-quality beer.

Both batch- and tunnel-pasteurization treatments failed, partly because the heating gelatinized the granular starch in the beer, making it excessively viscous. Partial microbiological control was obtained by flash-pasteurizing wort at 72–76 °C (161.6–168.8 °F) for 12–15 s using plate heat exchangers. Viscosity and flavour were scarcely altered, but because of the solids present complete sterilization was not achieved. Beer could be flash-pasteurized more successfully, at 75–80 °C (167–176 °F) for 20–25 s. However, all the carbon dioxide was removed and so the beer was ‘flat’, that is, it lacked effervescence and ‘tingle’. Carbonating this product failed, apparently because of difficulties caused by the high solids content. This flat beer has limited acceptability but some is sterile packaged and sold. Maintaining sterility has been difficult but where it has held the product has a long shelf-life. Another approach has been to bottle pasteurized beer with added yeast and a calculated amount of sugar, (a process closely similar to the traditional British process of conditioning ‘in bottle’ with added priming sugars and a secondary yeast). In the South African process ‘in bottle conditioning’ occurs as the yeast ferments for 5–12 days and the pressure of carbon dioxide rises to 20–30 psi, being limited by the amount of sugar added. The beer has an unusual flavour but it is acceptable and relatively stable (Harris, 1997). Bottles are said to have burst, possibly because of over-dosing with sugar, permitting an excessive accumulation of carbon dioxide, with a consequent excessive rise in pressure.

16.5 Beer composition and its nutritional value

Opaque beers are valuable foodstuffs, and are the best of all the alcoholic beverages in this respect. However, there is no reliable way to decide exactly how important they are in practice. There are several reasons for this. Home-brewed beers almost certainly vary very greatly in their compositions (but these are unknown) and the natures and proportions of the raw materials used, the quantities of beer drunk, when (consumption varies with the season) and by whom, and the nutritional status of the drinkers all vary (Daiber and Taylor, 1995; Haggblade and Holzzapfel, 1989; Heerden, van, 1989a, b; Novellie and De Schaepdrijver, 1986). Many years ago it was noted that in some seasons the men of particular tribes lived on beer alone for extended periods. As there is a gradation between soured, acidified, essentially alcohol-free porridges and acidified beers, and as the alcohol contents of the beers are variable and are continually increasing as fermentation continues, no conclusions regarding alcohol consumption can be drawn. With commercial beers the alcohol contents, at the time of sale, are relatively low (generally 3% or less) compared to clear beers (3–9%) and very much less than in wines (11–13%) or spirits (often 40%).

The nutrients present in beers, particularly the vitamins, are derived from the raw materials, *Lactobacilli* and the yeast. Some of the materials initially present in the wort

are taken up by the *Lactobacilli* and the yeast and may be converted into different substances. Some nutrients are destroyed by the brewing process, while those that are present in the beer may not be 'bio-available' and cannot be used by the consumer. The compositions of several commercial beers have been reported. Ranges (and mean values) for eight beers were: energy content, in kJ/litre, 1,530–1,840 (1,651); alcohol content, in g/litre, 16–32 (25.4); crude protein, g/litre, 4–9 (5.4); fat, g/litre, trace 1 (trace); crude fibre, g/litre, trace 1 (trace); ash, g/litre, 1–2 (1.13); carbohydrate, g/litre, 32–59 (47.6). Starch contents of five beers ranged between 27.8 to 32.7 g/litre (mean 29.7) and the values for three vitamins in 15 beers, all in mg/litre, were thiamine 0.13–0.36 (0.24); riboflavin, 0.30–0.47 (0.39) and for nicotinic acid, 2.32–3.74 (2.93) (Heerden, van, 1989b). Some contents of mineral elements, ranges and mean values all in mg/litre were potassium, 145–438 (280); sodium, 7–46 (21); calcium, 22–57 (38); magnesium, 69–174 (111); copper, 0.11–0.26 (0.18); iron, 0.9–2.1 (1.4); manganese, 0.8–2.2 (1.4) and zinc, 1.0–1.9 (1.4) (Novellie and De Schaepdrijver, 1986). Phosphorus contents, in other estimates on five beers, in mg/litre, were 96–565 (218).

Although particular substances are present in beers it does not follow that they are available to the imbiber. The living yeast in opaque beers takes up many vitamins quickly and these, together with those already present in the micro-organisms, are then largely unavailable. Heat treating or pasteurizing the beer damages or kills the yeast and the vitamins are released into solution and are then available. Analysis of beer crude protein shows that a significant amount is present, with a 'plant-like' distribution of amino acids, which do not contain an ideal mixture of nutritionally essential amino acids but which, nevertheless, has a good proportion of the essential amino acid lysine, which is probably derived from the yeast. As the lysine may be largely contained within the yeast cells, its availability is in doubt.

Some phosphorus could be present as phytic acid (*meso*-inositol hexaphosphate, (4.156)), a substance with strong chelating properties that can limit the nutritional availability of metal ions. However, and in contrast to many other cereal-based products, phytate was not detected in significant amounts in these beers. The replacement of sorghum grain adjunct with refined maize grits (from which the nutrient-rich embryos and aleurone layers have been removed) in both commercial and home brewing, and the progressive reduction in the proportion of sorghum malt used in the grist in commercial brewing (facilitated by the increasing DP values of sorghum malts and the supplementation of these malts with microbial amylases) are changes which have reduced the nutritional values of beers, in particular the B vitamin contents, and have led to the proposal that maize grits should be replaced with the traditional whole sorghum grain and the beers be supplemented with vitamins, thiamine and vitamin C (ascorbic acid; Heerden, van, 1989 a, b). Home-brewed beers, made with higher proportions of sorghum malt than are used in commercial brewing, are probably nutritionally superior. In addition to the B vitamin content these beers almost certainly contain higher levels of desirable crude fibre since the 'home' straining procedures are less stringent than those used in commercial brewing. Probably each litre of commercial beer consumed can provide 10% of the daily recommended protein requirement and 14% of the energy requirement of a moderately active man and is a useful source of the B vitamins thiamine, riboflavin and nicotinic acid as well as the minerals iron, zinc, manganese, magnesium and phosphorus. The starch is a good energy source but the alcohol is less good. Drinkers usually consume about two litres (3.52 imp. pints) of opaque beer/day.

Specifications for commercial beers are likely to include values for total solids, crude protein and lactic acid contents, pH, alcohol content when sold, (3% or less in South

Africa), and an upper limit on volatile acids (as acetic acid). In addition the products must be free of pathogenic organisms, must not have a tendency for the solids to separate and precipitate, have an appropriate viscosity, appearance, (colour, opacity and foam), and be acceptable as judged by a taste panel.

16.6 References

- BRIGGS, D. E. (1998) *Malts and Malting*. Aspen Publishing, Inc., Gaithersburg, MD, 796 pp.
- CHEVASSUS-AGNES, S., FAVIER, J. C. and ORSTOM, A. J. (1976) *Cahiers Nutr. Diet.*, **11** (2), 89.
- DADA, L. O. and DENDY, D. A. V. (1987) *Tropical Sci.*, **27**, 101.
- DAIBER, K. H. (1975) *J. Sci. Fd. Agric.*, **26**, 1399.
- DAIBER, K. H. (1978) *Special Report BB114. Manual on the treatment and malting of birdproof grain sorghum*. The Sorghum Beer Unit, CSIR, South Africa. 12 pp.
- DAIBER, K. H. and TAYLOR, J. R. N. (1995) in *Sorghum and Millets: Chemistry and Technology*. (Dendy, D. A. V. ed.), A. A. C. C. St Paul, Minn. p. 299.
- DAIBER, K. H., MALHERBE, L. and NOVELLIE, L. (1973) *Brauwissenschaft*, **26** (7), 220, 248.
- DENDY, D. A. V. (ed.) (1995) *Sorghum and Millets; chemistry and Technology*. Amer. Assoc. Cereal Chemists. St. Paul, Minn.
- DEWAR, J. and TAYLOR, J. R. N. (1995) *Proc. 5th Sci. Tech. Conv. Inst. of Brewing, (Central and Southern African Sect.)*, Victoria Falls, p. 93.
- DEWAR, J., OROVAN, E AND TAYLOR, J. R. N. (1997a) *J. Inst. Brewing*, **103**, 283.
- DEWAR, J., TAYLOR, J. R. N. and BERJAK, P. (1997b) *Proc. 6th Conv. Inst. of Brewing (Central and Southern African Sect.)*, Durban, p. 29.
- DEWAR, J., TAYLOR, J. R. N. and BERJAK, P. (1997c) *J. Cereal Sci.*, **26**, 129.
- DEWAR, J., TAYLOR, J. R. N. and BERJAK, P. (1997d) *J. Inst. Brewing*, **103**, 171.
- DEWAR, J., DONALDSON, S. and TAYLOR, J. R. N. (1999) *Proc. 7th Conv. Inst. of Brewing (African Sect.)*, Nairobi, p. 217.
- DIEFENBACH, M. (1996) *Brauwelt Internat.*, **14** (5), 431.
- DIRAR, H. A. (1978) *J. Food Sci.*, **43**, 1983.
- EKUNDAYO, J. A. (1969) *J. Food Sci.*, **4**, 217.
- EZEOGU, L. I. and OKOLO, B. N. (1994) *J. Inst. Brewing*, **100**, 335.
- EZEOGU, L. I. and OKOLO, B. N. (1995) *J. Inst. Brewing*, **101**, 39.
- EZEOGU, L. I. and OKOLO, B. N. (1999) *J. Inst. Brewing*, **105**, 49.
- FAPARUSI, S. I. (1970) *J. Sci. Food Agric.*, **21**, 79.
- FAPARUSI, S. I., OLOFINBOBA, M. O. and EKUNDAYO, J. A. (1973) *Zeits. f. Allg. Mikrobiologie*, **13** (7), 563.
- FOX, F. W. (1938) *J. S. African Chem. Inst.*, **21**, 39.
- GLENNIE, C. W. (1983) *J. Agric. Food Chem.*, **31**, 1295.
- GLENNIE, C. W. (1988) *Starch/Stärke*, **40** (7), 259.
- HAGGBLADE, S. and HOLZAPFEL, H. (1989) in *Industrialization of Indigenous Fermented Foods* (Steinkraus, K. H. ed.). Marcel Dekker Inc. New York, p. 191.
- HARRIS, R. N. (1997) *Proc. 6th Conv. Inst. of Brewing (Central and Southern African Sect.)*, Durban, p. 89.
- HARRIS, R. N., MATHIBA, K., JOUSTRA, S. M., VILJOEN, C. R. and YENKETSWAMY, C. (1999) *Proc. 7th Conv. Inst. of Brewing (African Sect.)*, Nairobi, p. 218.
- HEERDEN, I. V. VAN (1989a) *J. Inst. Brewing*, **95**, 17.
- HEERDEN, I. V. VAN (1989b) *Proc. 2nd Sci. Tech. Conv. Inst. of Brewing (Central and Southern African Sect.)*, Johannesburg, p. 293.
- IWUAGWU, Y. O. U. and IZUAGBE, Y. S. (1985) *J. Appl. Bacteriol.*, **59**, 487.
- MIRACLE, M. P. (1965) in *Food Technology the World Over* (Peterson, M. S. ed.). Avi Publishing, Westport, Conn. p. 107.
- MORCOS, S. R., HEGAZI, S. M. and EL-DAMHOUGY, S. T. (1973) *J. Sci. Food Agric.*, **24**, 1157.
- MORRALL, P., BOYD, H. K., TAYLOR, J. R. N. and VAN DER WALT, W. H. (1986) *J. Inst. Brewing*, **92**, 439.
- NOUT, M. J. R. (1980) *Chem. Mikrobiol. Technol. Lebensm.*, **6**, 137, 174.
- NOUT, M. J. R. and DAVIES, B. J. (1982) *J. Inst. Brewing*, **88**, 157.
- NOVELLIE, L. (1966) *Internat. Brew. Distill.*, **1** (1), 27.
- NOVELLIE, L. (1968) *Wallerstein Labs. Commun.*, **31**, 17.
- NOVELLIE, L. (1977) in *Proc. of a Symp. on Sorghum and Millets for Human Foods*. (Dendy, D. A. V. ed.), The Tropical Products Institute, London. p. 73.
- NOVELLIE, L. and DE SCHAEPPRIJVER, P. (1986) in *Progress in Industrial Microbiology*. **23. Microorganisms in the production of food. (Adams, M. R. ed.), Elsevier, Amsterdam, p. 73.**
- NZALIBE, H. C. and NWSIKE, C. C. (1995) *J. Inst. Brewing*, **101**, 345.

- OGUNDIWIN, J. O. (1977) *Brew. Distill. Internat.*, **7**(6), 40.
- OKOLO, B. N. and EZEUGU, L. I. (1996) *J. Inst. Brewing*, **102**, 79, 277.
- O'ROURKE, T. (2001) *Brewer Internat.*, **1**(10), 46.
- OXFORD, T. (1926) *J. Inst. Brewing*, **32**, 314.
- PANASIUK, O. and BILLS, D. D. (1984) *J. Food Sci.*, **49**, 791.
- PATHIRANA, R. A., SIVAYOGASUNDARAM, K. and JAYATISSA, P. M. (1983) *J. Food Sci. Technol.*, **20**(3), 108.
- PERISSE, J., ADRIAN, J., REVET, A. and LE BARRÉ, S. (1959) *Ann. de la Nutrit. et de l'Aliment.*, **13**(1), 1.
- PETERSON, M. S. and TRESSLER, D. H. (1965) *Food Technology the World Over*. 2. *South America, Africa, Middle East and Asia*, Avi Publishing, Westport, Conn. p. 130.
- PICKERELL, A. T. W. (1986) *J. Inst. Brewing*, **92**, 568.
- SCHWARTZ, H. N. (1956) *J. Sci. Food Agric.*, **7**, 101.
- TAYLOR, J. R. N. (1989) *Proc. 2nd Sci. Tech. Conv. Inst. of Brewing (Central and Southern African Sect.)*, Johannesburg, p. 275.
- TAYLOR, J. R. N. (1991) *Proc. 3rd Sci. Tech. Conv. Inst. of Brewing (Central and Southern African Sect.)*, Victoria Falls, p. 18.
- TAYLOR, J. R. N. (1992) *J. Amer. Soc. Brew. Chem.*, **50**, 13.
- TAYLOR, J. R. N. and DEWAR, J. (1994) *J. Inst. Brewing*, **100**, 417.
- YOUNG, R. S. (1949) *J. Inst. Brewing*, **55**, 371.

Microbiology

17.1 Introduction

The design of the brewery plant and operation of the process must be such that production yeast strains remain segregated with no possibility of inter-mixing. In addition, contamination with foreign micro-organisms must be prevented. These goals can be achieved by ensuring high standards of hygiene within the brewery. Brewery plant is constructed from stainless steel for ease of cleaning. The modern process tends to be fully enclosed to ensure that a microbiological barrier is maintained between process liquids and the external environment. All critical parts of the plant are fitted with automatic and efficient cleaning in place (CIP) systems. The microbiological integrity of the brewing process must be confirmed with appropriate testing. For a complex process such as brewing this necessitates the adoption of a sampling plan to ensure that all stages are checked where there is a risk of introduction of contaminants. The samples must be representative of the process stream they are taken from. It follows that the sampling devices must be fit for this purpose. Analysis of the samples may use classical microbiological techniques, in other words, inoculation into a suitable medium, incubation and scoring for growth. This 'classical' approach is a valuable aid to validating the microbiological integrity of the process. Several selective media are in common usage, which have been developed specifically for the isolation and identification of brewery contaminants. Several days are usually required before a result is obtained, therefore the data is 'historical' and cannot be used for immediate hygiene control. Nevertheless, routine microbiological testing is valuable when used for trend analysis.

Microbiological testing of some samples must cope with the presence of production yeast strains. Methods for the identification and differentiation of brewing strains are described in Chapter 13 (Section 13.10). Several selective media have been devised which allow the identification of bacteria and non-brewing, so-called wild yeast contaminants in the presence of high concentrations of brewing yeast. Validation of cleaning cannot be usefully checked with conventional microbiological methods since these are too slow for production requirements. Rapid procedures have been developed to

meet this need. These have been designed to detect instantly the presence of micro-organisms and soiling.

17.2 The microbiological threat to the brewing process

Micro-organisms may exert adverse effects on the brewing process both directly and indirectly. The direct effects are the obvious ones of contamination of wort or beer with foreign organisms. Oxygenated wort represents a comparatively rich source of nutrients capable of supporting the growth of a wide range of micro-organisms. The presence of hops is advantageous since *trans*-humulone, (–)-humulone and colupulone are inhibitory to many bacteria by virtue of their ability to act as ionophores (Verzele, 1986). Nevertheless, many micro-organisms, including yeast, are capable of growth in their presence. The effects of contamination range from comparatively minor changes in beer flavour and fermentation performance through to gross flavour defects and super-attenuation of worts. Once pitched the wort is, to some extent, protected by the yeast since many contaminants, if present at low levels, are not able to compete. Beer is a comparatively poor growth medium. The nutrients are limited to the small residue that remains after fermentation is completed. Beer is a relatively hostile environment to many micro-organisms. The antiseptic properties of hop compounds are augmented by ethanol. Low redox and acid pH provide additional protection against many potential spoilage organisms. Ethanol is a powerful inhibitor of microbial growth. Low and zero alcohol beers have a much increased susceptibility to spoilage compared to their alcoholic counterparts.

Several bacterial and some yeast species are capable of growth in beer. This can cause the formation of hazes, surface pellicles and many undesirable changes in beer flavour and aroma. The outward symptoms of these infections have been long recognized and many are characterized as ‘diseases’ of beers. These are usually descriptive of the changes in flavour and appearance.

Micro-organisms exert indirect undesirable effects on brewing in three ways. Firstly, growth on raw materials can produce undesirable changes such that the materials do not behave normally. Secondly, the growth of contaminants on raw materials can generate microbial metabolites, which can persist into the brewing process and exert deleterious effects. Thirdly, very heavily contaminated raw materials can introduce microbial biomass that persists into green beer. Although dead, the cells can cause beer filtration problems and even beer hazes if filtration is deficient.

From a microbiological standpoint, the brewing process is divisible into the steps leading up to wort production followed by those that include fermentation and subsequent beer processing. The copper boil separates these two parts. This process step serves many functions, one of which is to sterilize wort (Chapters 9, 10). It follows that some microbiological contamination can be tolerated in the process steps preceding the copper boil, although with the caveat that the raw materials must be within specification. The steps after the copper boil are those in which the risk of contamination is highest and where the greatest caution must be exercised. Any brewing raw material that is capable of supporting microbial growth has the potential to produce unwanted metabolites that can persist through the brewing process and produce adverse effects. Water is a special case in that microbial metabolites can be introduced even though the organism does not have direct contact with any other brewing materials. To counteract this threat all water, especially from wells, should be carbon filtered to remove organic contaminants (Chapter 3).

Sugar syrups may become tainted as a result of the growth of osmophilic moulds and yeasts (Chapter 2). Growth on the surface of the syrup can occur where inappropriate storage conditions allow the formation of condensation resulting in a localized sugar dilution and lower water activity. Growth of contaminants may proceed since the inhibitory effects of high osmotic potential are reduced. This should be guarded against by storage of syrups at an appropriate temperature and preferably under an inert gas such as carbon dioxide or nitrogen.

Malt and adjuncts derived from cereals present the greatest threat. Poor control of the steps involved in the manufacture of these ingredients can result in mould growth. Species of moulds from genera such as, *Alternaria*, *Aspergillus*, *Cladosporium*, *Fusarium* and *Rhizopus* have all been reported to produce adverse effects (Flannigan, 1999). Excessive mould growth produces many metabolites that can produce off-flavours and aromas in beers. Terms such as molasses, stale, burned and winey have all been used to describe the effects. In addition, changes in colour may also occur. The metabolites producing these effects also result in increased nitrogen levels in worts and beers. In extreme cases, beer hazes may be generated.

The most widely recognized defect ascribed to the growth of mould on malts is that of gushing. This phenomenon occurs in bottled beers where on broaching there is a sudden loss of carbon dioxide with concomitant uncontrolled foaming. Studies have demonstrated that culture filtrates of several moulds, especially *Fusarium* spp, were capable of inducing gushing when added to beers (Amaha *et al.*, 1974; Kitabatake and Amaha, 1974). Small polypeptides have been isolated that are apparently responsible for the phenomenon. In one case a concentration as low as 0.05 ppm was sufficient to produce the effect (Kitabatake and Amaha, 1974). Moulds capable of producing gushing-inducing metabolites are commonly those that also produce mycotoxins. Indeed, some, but not all, mycotoxins have been shown to be capable of inducing gushing. More than 200 distinct mycotoxins have been isolated from various fungi. They appear to function as facilitators of fungal pathogenesis. The most common are the trichothecenes of which around 150 have been recognized. Chemically, they are tetracyclic sesquiterpenes, the most common being nivalenol, deoxynivalenol and T-2 toxin. All are potent inhibitors of protein synthesis and possibly they disrupt membrane function. Trichothecenes are heat stable and therefore capable of surviving through the wort boil. They are toxic to humans and animals. Purely from a brewing standpoint, if present at high concentration they inhibit yeast growth. It has been suggested that they could in some circumstances be a cause of sticking fermentation (Boeira *et al.*, 1999a, b).

After wort boiling the microbiological integrity of the process is dependent upon good hygienic practice. The efficiency of CIP systems is of paramount importance to ensure that contamination is not introduced by unclean plant. Uninoculated wort, either in fermenter or propagater is at the greatest risk. This must be pitched as soon as possible after its production in order to minimize the risk of infection. Although beer is a relatively poor substrate, a substantial range of micro-organisms are capable of growth in it. It follows, therefore, that after wort, bright beer represents the second most vulnerable material. Entry of microbial contaminants can occur at any stage where liquid or gaseous additions are made to primary process streams. Some of these are illustrated in Fig. 17.1.

At the end of the process, the beer must be packaged in a way that renders it microbiologically stable throughout its expected shelf-life. In the case of small-pack products, in bottle or can, the most common option is to use a tunnel pasteurization process. The temperature and contact time must be controlled to ensure that each individual package receives the desired heat treatment. This requires careful design and

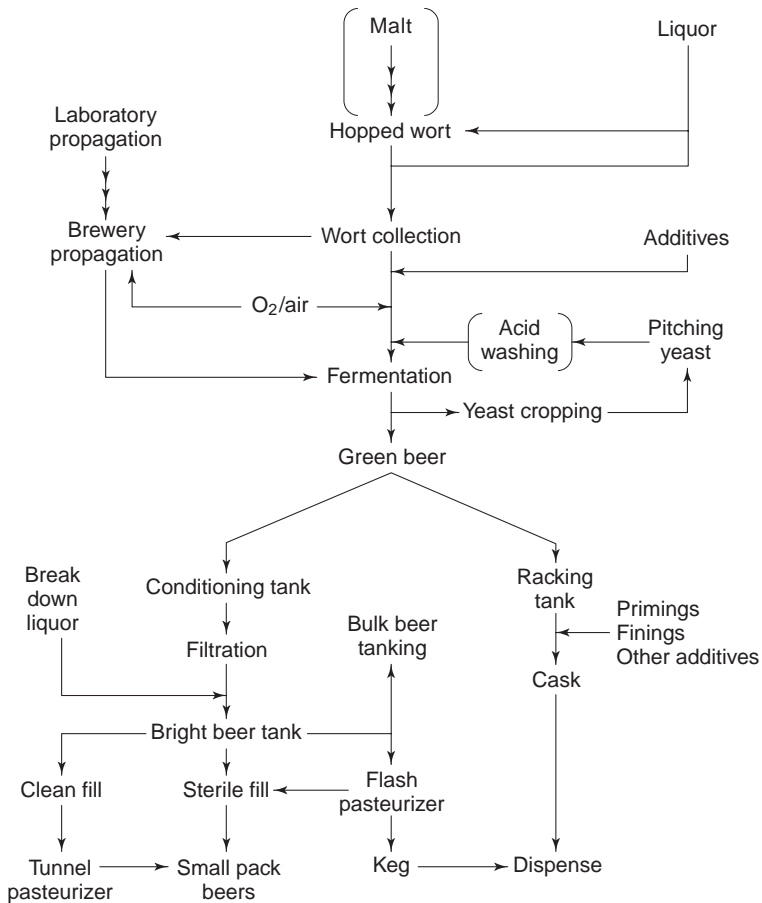

Fig. 17.1 Outline of the complete brewing process indicating steps in which there is a potential for microbiological contamination.

operation in the event of a packaging line stoppage. It is common practice in this situation to cool the pasteurizer to safeguard product already inside against heat degradation due to over-pasteurization. When product flow recommences, it is essential to delay forward movement of product within the pasteurizer until correct operating temperatures are attained.

For certain small-pack beers where the container cannot withstand heat and for keg beers the product is pasteurized in-line. This process is as efficacious as tunnel pasteurization, however it introduces extra risks. Thus, contamination is possible from the container or from the plant situated between the pasteurizer and package. Special precautions must be taken to ensure that this does not occur. Some flavour degradation is inevitable whenever beer is heated. To eliminate this it is becoming more common to package aseptically. In this case the in-line pasteurization step is replaced by sterile filtration. The equipment must be scrupulously clean and operated to the highest standards of hygiene.

In the case of draught beers, the possibility of microbiological spoilage extends beyond the brewery and into retail establishments. Beers in cask are to some extent protected by the endogenous flora of brewing yeast. Nevertheless, casks are vented to the

atmosphere for dispense and therefore open to the entry of contaminants. In a well-managed cellar this should not occur. Dispense systems for cask and keg beers are possible routes for contamination. In particular, the possibility of biofilm development must be guarded against by the use of appropriate cleaning regimes. It is essential to consider the microbiological implications of introducing new products, plant and processes into the brewery. Introduction of a new raw material has the potential to import a whole new spectrum of microbial contaminants, which have not been encountered hitherto. This is of special note where the production of beverages other than beers is introduced into a brewery. For example, the use of non-sterile fruit concentrates, which are ingredients in flavoured alcoholic beverages. If these are used in the same plant as beer, great caution should be exercised to ensure that the coexistence of these distinct product streams is microbiologically robust. In particular, it should be realized that media designed for the detection of typical brewery contaminants may not be suitable for non-brewing micro-organisms.

It is important to consider any microbiological implications where modifications to the brewing process are made. A move from pasteurization to sterile filling heightens the risk of microbiological failure and the precautions to prevent this need to be made correspondingly more stringent. However, in some instances apparently unrelated changes can have unexpected consequences. For example, on quality grounds there has been a gradual tightening in specification regarding maximum dissolved oxygen concentrations in product both in process and package. This decreases the overall risk of spoilage by preventing the growth of obligate aerobes. On the other hand, it provides a better selective medium for obligate anaerobes. In fact, bacterial infections of beer by anaerobes such as *Pectinatus* have been recorded only in relatively recent times and are taken to reflect the gradual reduction of in-process oxygen exposure (Section 17.3.3).

17.3 Beer spoilage micro-organisms

Beer is liable to spoilage by a range of micro-organisms, both bacteria and yeasts. Spoilage results in the formation of hazes, undesirable flavours and aromas. Although beer is rendered unpalatable, the growth of contaminants does not generally lead to health risks. There are some exceptions to this general statement, as discussed subsequently, however pathogenic micro-organisms do not survive in beer.

17.3.1 Detection of brewery microbial contaminants

Routine microbiological testing in the brewery is usually restricted to enumerating populations. In many situations, no contamination whatsoever should be detected. In other cases, some contamination is inevitable. Maintaining a record of the numbers of micro-organisms detected provides a useful method of assessing the general cleanliness of the brewery environment, the robustness of cleaning regimes and the microbiological integrity of the process. Methods must be capable of detecting low concentrations of contaminants in isolation (as in bright beer) or in the presence of high concentrations of other micro-organisms (as in detection of low levels of bacteria in pitching yeast slurries).

In traditional practice, microbial contamination is detected by taking a suitable sample from the brewery and inoculating it into an appropriate solid or liquid microbiological medium. Appropriate sampling devices and procedures have been developed for the routine testing of process liquids, gases and surfaces. These are described in Section 17.5.

After incubation, to allow any micro-organisms to grow to a detectable concentration, the cultures are examined for the presence or absence of growth. Growth can be detected via the visible formation of hazes in liquids or as colonies on solid media. Many selective media are used that contain components that allow the growth of specific strains and not others. Descriptions of common microbiological media used in brewing are provided in Section 12.3.5.

Growth can be quantified by performing cell counts. This may be via direct microscopic enumeration using a counting chamber. Microscopic examination of contaminants provides a useful method for preliminary identification. More commonly, cell concentrations are determined by making colony counts where serial dilutions of the test sample are streaked out into solid media or collected on a membrane which is then placed on solid medium. After incubation under appropriate conditions, any colonies that arise are assumed to have formed from single cells. Therefore, the colony count is directly proportional to the cell concentration in the original sample.

Conventional microbiological techniques will continue to have a place in brewery laboratories because they are relatively inexpensive and do not require sophisticated apparatus. They suffer the drawback of slowness and produce data that is of historical interest only. More rapid techniques are needed for validating the microbiological integrity of the brewing process in real time. Rapid methods are of two general types (reviewed by Russell and Dowhanick, 1999). Firstly, those that require a growth stage before the organisms can be detected. Secondly, those able to detect very low levels of contamination in samples without the need for pre-treatment. All rapid detection methods rely on three general principles, used alone or in combination, for their operation. These are pre-concentration, low threshold of detection and specificity. Some rapid methods, particularly those with a high degree of specificity, combine elements of detection and identification. These are described below.

Low levels of contaminants in samples containing little extraneous solid material can be concentrated by filtration through a sterile membrane filter. The approach can be applied to both liquids and process gases. The membrane must be sufficiently porous to allow throughput of a large sample volume but have a pore size small enough to retain bacteria. Typically, 0.22 or 0.45 μm membrane filters are used for this purpose. The membrane is transferred to a Petri dish containing a suitable solid nutrient medium, incubated and examined for growth. The procedure can be made rapid by examining the membrane under a microscope and looking for micro-colonies. Commonly, membranes are stained to aid visualization of the colonies. Preferably fluorescent stains are used that are incorporated into the medium. This approach has the advantage that viable and non-viable cells can be differentiated and cells can be recovered for further analysis. The micro-colony method can produce a result within approximately 24 hours, thus saving several days compared to traditional techniques.

The direct epifluorescent filter technique (DEFT) uses a membrane filtration step to concentrate low concentrations of contaminants. No pre-growth stage is required because any cells trapped on the membrane are visualized by microscopic examination after staining with a fluorescent dye, usually acridine orange. This dye binds to single-stranded RNA molecules, which are plentiful in viable cells, and produces orange fluorescent cells. Dead cells are deficient in single stranded RNA and these stain green due to the natural fluorescence of double-stranded RNA. Other dyes have also been used such as berberine sulphate (in conjunction with acridine orange), aniline blue, Viablue and some tetrazolium salts. Reportedly, these produce improved staining reactions, which make easier differentiation between microbial cells, inanimate debris and the membrane. The

procedure can be automated using computer-assisted image analysis. Results can be obtained within 30 minutes. The sensitivity of the approach is such that a single microbial cell can be detected on a membrane.

Procedures that rely on pre-incubation and a low threshold of detection use indirect methods for detecting microbial growth. In clear liquid media the presence of microbial cells can be detected using turbidometry or spectrophotometry. Using appropriate apparatus changes can be detected before visual turbidity becomes apparent. The growth of micro-organisms is an exothermic process. Apparatus has been developed that detects growth-related exothermy as an electrical current via the intermediary of a thermocouple. Impedometric devices detect changes in electrical properties of the medium brought about by microbial growth. As growth proceeds, the uptake of nutrients and the formation of extracellular ionic metabolites result in a change in the conductance and capacitance of the medium. Commercial apparatus has been developed capable of measuring these changes and thereby rapidly detecting microbial growth (for a review, see Fleet, 1992).

The time required to reach the threshold of detection of microbial growth using these methods is dependent upon the size of the inoculum and the growth rate of the organism therefore the time required to obtain a result is dependent on the nature of the sample and the concentration and identity of the contaminants. The procedures can be used in forcing tests where the undiluted sample is assessed, for example, analysis of bright beer. Alternatively, samples may be inoculated into a suitable growth medium. The presence of low levels of bacterial contamination in the presence of high concentrations of yeast, for example in pitching slurries, can be accommodated by the incorporation of cycloheximide to inhibit yeast growth. Compared to traditional microbiological techniques the rapid procedures use expensive and relatively sophisticated apparatus. A decision must be made as to whether or not the size of the brewing operation merits the required capital investment.

All living organisms contain adenosine triphosphate (ATP). Therefore, the presence of ATP is indicative of biological activity. ATP is easily detected using the phenomenon of bioluminescence (Simpson, 1999). The firefly, *Photinus pyralis* contains an enzyme, luciferase. In the presence of oxygen and ATP, luciferase catalyses a reaction in which a substrate termed luciferin (6-hydroxybenzothiazole) is oxidized to oxyluciferin. During the reaction ATP is hydrolysed to AMP. For each mole of ATP hydrolysed, a photon of light with an emission maximum of 532 nm is released.

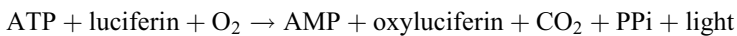

The bioluminescence reaction has been utilized for many years as the basis of an ATP determination. It is now routinely applied to the detection of ATP in industrial environments as a means of validating cleaning regimes (Ogden, 1993). Early devices relied on sampling using a sterile swab followed by rinsing into a cuvette, addition of appropriate reagents and insertion into a bioluminometer to obtain a reading. These approaches needed skilled laboratory personnel. More modern versions utilize all-in-one arrangements, where sampling device and reagents are incorporated into a single unit. Samples may be taken in the form of swabs to check the cleanliness of surfaces or as liquid taken from terminal rinse water. The measuring unit usually includes a data capture system to facilitate the maintenance of records. Operation does not require any skill other than the ability to follow simple instructions.

Several commercial ATP bioluminometers are now available. Unfortunately, there has been no agreement to standardize the results of the measurement. Arbitrary values of

bioluminescence, termed relative light units (RLU), are used. The output from individual instruments differs for a constant ATP concentration. It is necessary, therefore, to calibrate and set standards for each instrument. Typically, a range of target values in RLUs is established for each location under test. The lower limit is classed as a pass, an intermediate value indicates caution and should prompt a check of the CIP system. A value above an upper limit defines a fail and indicates the need for a check of the CIP system and repeat clean.

Correlation between luminescence and microbiological counts is usually poor because ATP concentration varies widely between different species and the same species in different physiological states. In general, yeast cells contain around 100 times more ATP than bacterial cells (Hysert *et al.*, 1976). In brewing the situation is more confusing since beer also contains significant and very variable levels of ATP. Thus, Simpson *et al.* (1989) reported mean levels of ATP in beer of 5 nM but with a range of 0.01 to 100 nM. For this reason, bioluminometry cannot differentiate between soil and microbial contamination. It also follows that it is not as sensitive as some direct microbiological analytical techniques. The DEFT technique is capable of detecting a single cell on a membrane. ATP bioluminescence apparatus designed for hygiene testing can detect between 5 and 250 cells (Boulton and Quain, 2001). Despite the issues regarding sensitivity it is the method of choice for validating cleaning regimes both in the brewery and for dispense lines in licensed premises.

Refinements of the ATP bioluminescence method have allowed the detection of individual microbial cells in beer. For example, the Sapporo Breweries in Japan have developed apparatus termed the MicroStar RMDS-SPS (Rapid Microbe Detection System – Sapporo Special) in which beer samples are passed through a membrane filter. Reagents are sprayed directly onto the membrane and the bioluminescence due to any trapped micro-organisms detected by a photomultiplier linked to a computer for data collection. The apparatus can be used to detect very low concentrations of beer spoilage bacteria by pre-incubation of the membrane on a suitable nutrient medium for two days, prior to performing the ATP analysis (Takahashi *et al.*, 1999a).

17.3.2 Identification of brewery bacteria

Even in the best-managed brewery occasional microbiological failures do occur. In these instances, identifying the organism can be a valuable aid in tracing the nature of the process failure. Identification may be made according to taxonomic principles. In addition, it may be of equal value to make identification based on more pragmatic grounds. For example, differentiation of production and wild yeast strains. Bacteria encountered during brewing are classified and identified using classical microbiological techniques such as cellular morphology, possession or lack of motility, colonial morphology when cultivated on solid media and biochemical properties. Bacterial morphologies are classified as being rod-shaped (bacilli) or spherical (cocci). The size of bacilli and cocci and whether or not the cells are borne singly, in chains or clusters are all diagnostic of individual species. The examination of cellular morphology is aided by the use of biological stains. These assist with visualizing cells for microscopic examination.

The response of individual species to some stains is of taxonomic significance. The most widely used of these is the Gram stain. Gram positive bacteria are stained purple by treatment of a heat fixed smear with the dye, crystal violet. The procedure involves subsequent steps in which the smear is treated with a solution of iodine and potassium iodide (Gram's iodine) followed by washing with ethanol and counter-staining with a

pink dye, safranin. Gram negative cells are stained pink because the ethanol step removes the complex of crystal violet and Gram's iodine from fixed cells. The differential staining response of the two bacterial groups is due to differences in the structures of the cell walls. All bacterial cell walls contain peptidoglycan as a structural component. In Gram positive bacteria this forms a much thicker layer compared to Gram negative types. In consequence, in the former the complex of crystal violet and Gram's iodine remains trapped following treatment with ethanol.

The biochemical properties of bacteria can be assessed using a number of tests. Some of these are summarized in Table 17.1. These tests determine fundamental aspects of the physiology of individual strains such as the ability to utilize various sources of carbon and nitrogen and to grow aerobically or anaerobically. Other procedures look for the possession of specific enzymes. For example, bacteria that possess catalase are able to decompose exogenous hydrogen peroxide. The ability to produce specific metabolic end products can be probed by a number of tests. These usually take the form of preparing a culture of the bacteria under investigation. The presence of a particular metabolite is confirmed by the addition to the culture of reagents that bring about a colour change. Commonly, these tests detect the formation of metabolites that would cause recognizable defects in infected beers.

Several techniques have been developed that allow the rapid identification of bacteria. These use the same principles as those methods used to differentiate yeast strains (described in Chapter 13). For completeness, a brief overview of the most promising methods is given in Table 17.2. A comprehensive review may be found in Gutteridge and Priest (1999). Undoubtedly, conventional microbiological techniques in conjunction with hygiene testing via bioluminescence will continue to be the system of choice of quality control for many brewers. However, rapid methods of detection and identification are likely to become increasingly important as brewers move from quality control to quality assurance. This strategy requires that specific spoilage organisms are identified as soon as possible since they pose the greatest potential threat. This is all the more important since the trend towards packaging of beers aseptically without pasteurization seems likely to grow.

The application of the rapid techniques outlined in Table 17.2 to beer spoilage bacteria has been reported. For example, use of DNA polymerase technology (Dimichele and Lewis, 1993; Tsuchiya *et al.*, 1992a,b), use of membrane filtration and automatic detection of bacteria with specific fluorochromes and image analysis (Yasui and Yoda, 1997), electrophoretic characterization of lactate dehydrogenases of *Lactobacillus brevis* (Takahashi *et al.*, 1999b), and identification of lactic acid bacteria using monoclonal antibodies (Yasui and Yoda, 1997).

17.3.3 Gram negative beer spoiling bacteria

A brief description of the Gram negative bacteria associated with beer spoilage and the defects produced by their growth is given in Table 17.3 (review, Fleet, 1992). The stages in the brewing process at which these bacteria exert their effects and the defects that are produced are dependent upon the physiological capabilities of the organisms. The descriptions of the bacterial species in Table 17.3 provide an immediate indication of the stages in brewing where the results of their spoilage may become evident. Thus, acetic acid bacteria are obligate aerobes and produce acetic acid from ethanol. The concentration of ethanol that may be tolerated varies between strains. In early work, Shimwell (1936) reported that none could grow at ethanol concentrations greater than 6%

Table 17.1 Traditional microbiological techniques used in the identification of brewery bacteria

Test	Basis
1. Carbon source utilization	Score for growth on minimal medium supplemented with various sole carbon sources.
2. Nitrogen source utilization	Score for growth on minimal medium supplemented with various sole nitrogen sources.
3. Production of acid and/or gas	As for (1), but medium supplemented with methyl red, formation of a red colour indicates the formation of acid. Incorporation of a small inverted (Durham) tube in the medium allows the detection of the formation of gas (bubble formation).
4. Catalase test	Pour solution of hydrogen peroxide onto surface of slope culture. Catalase positive bacteria produce copious frothing.
5. Indole test	Ethanol solution of dimethylamidobenzaldehyde in presence of HCl and potassium persulphate added to peptone water culture. The presence of indole is indicated by the formation of a red coloration.
6. Voges-Proskauer (VP) test	The presence of acetoin and diacetyl in peptone water culture indicated by the formation of a red coloration following the addition of α -naphthol and creatine.
7. Formation of hydrogen sulphide	Bacterial (and yeast) colonies develop black coloration when grown on nutrient medium and then overlaid with paper soaked in lead acetate solution.
8. Nitrate reduction	Inoculate a broth culture supplemented with 0.1% potassium nitrate. The presence of nitrite is detected by the formation of a pink colour following the addition of a solution of α -naphthylamine containing acetic and sulphanilic acids.

Table 17.2 Rapid methods for the identification of brewery bacteria (Boulton and Quain, 2001)

Test	Principle
1. Genomic analysis	Hybridization of unknown genome with DNA or RNA probe(s) from known organism.
2. Proteomic analysis	Extraction of proteome and analysis via electrophoresis. Identification via comparison with electrophoretograms made from the proteomes of known organisms. Analysis of extracted proteome and identification of selected proteins via binding to specific labelled antibodies. Whole cell pyrolysis under inert atmosphere and analysis of sub-cellular fragments via gas chromatography (Py-GC) or mass spectroscopy (Py-MS).
3. Analysis of cellular components	Whole cell extraction of fatty acids and identification from GC profiles of fatty acid methyl esters (FAME). Analysis of whole cells via Fourier transform infra-red spectroscopy (FT IR). Analysis of whole cells via ultraviolet resonance Raman spectroscopy (UV RS)

v/v. Subsequently, other workers have reported that some strains can grow in ethanol concentrations up to 10% v/v (De Ley *et al.*, 1984) and *Gluconobacter oxydans* can survive 13% v/v (Magnus *et al.*, 1986). Some strains can grow under micro-aerophilic conditions. They are tolerant of ethanol, hop resins and low pH. Typically, they spoil beer where some oxygen is present, as might be the case in licensed premises where air is allowed to enter casks. Beer lines and dispense equipment are frequently contaminated by acetic acid bacteria. Spoilage becomes evident in the form of surface pellicles, turbidity and ropiness. The latter refers to the formation of extracellular polysaccharide material, which can be seen suspended as slime in the infected beer. Infected beer becomes acid and off-flavours develop. Acetic acid bacteria are ubiquitous in brewery and licensed premises. However, they should be easily controlled by the use of appropriate hygiene regimes. In particular, dispense systems must be kept scrupulously clean. The best safeguard against acetic acid bacterial infection of beers is to eliminate oxygen.

Members of the *Enterobacteriaceae* associated with spoilage (*Obesumbacterium*, *Rahnella*, *Citrobacter* and *Klebsiella*) are related to those such as *Escherichia coli* that are commonly found in the gut of mammals. For this reason they are referred to as coliforms. It should be stressed that none of those that are found as contaminants in the brewing process are pathogens. They are facultative anaerobes. In other words, they are capable of growth under both aerobic and anaerobic conditions. In the context of brewing this increases the number of locations where spoilage can occur. However, other metabolic constraints limit the niches that these bacteria are able to occupy. All of the species of beer spoilage *Enterobacteriaceae* are tolerant of hop resins and they can ferment a range of sugars but cannot utilize ethanol. In consequence they are wort contaminants and capable of exerting deleterious effects during fermentation. They do not spoil beers.

Members of the *Citrobacter* and *Klebsiella* genera are sensitive to ethanol and do not survive beyond the end of fermentation. *Rahnella* and *Obesumbacterium* are more tolerant of ethanol but nevertheless do not survive very high-gravity fermentations. In lower-gravity fermentations they can persist and indeed grow with the yeast. *Rahnella* and especially *Obesumbacterium* can be cropped with the yeast, survive during storage and, if steps are not taken to remove them, they can then infect future fermentations. Growth of coliforms on wort during fermentation produces a variety of tastes and aromas ranging from sweet/honey/fruity through to vegetable/faecal. A multitude of bacterial metabolites is responsible for these flavour changes. These include various esters, higher alcohols, organic acids, acetaldehyde, diacetyl, acetoin, dimethyl sulphide and dimethyl disulphide. This range of end products is a reflection of the metabolic versatility of these bacteria. In addition to the common pathways for the metabolism of glucose via glycolysis and the hexose monophosphate shunt (Chapter 12, Figs 12.5 and 12.7) some Enterobacteria possess an alternative route, the Entner-Duodoroff pathway. In the latter, glucose is degraded to give 2-oxo-3-deoxy-6-phosphogluconate, which is then cleaved to form pyruvate and glyceraldehyde 3-phosphate (Fig. 17.2).

Two major fermentative routes occur in different genera of the *Enterobacteriaceae*. These differ based on the relative formation of organic acids and acetoin plus 2,3-butanediol (Fig. 17.3). In mixed acid types the major end products are organic acids and only small amounts of acetoin and 2,3-butanediol are formed. These types, which include *Citrobacter* and *Obesumbacter*, test positive with the methyl red test but negative with the Voges-Proskauer test. The non-mixed acid group, which includes *Klebsiella* and *Rahnella* produce high concentrations of acetoin and 2,3-butanediol and in consequence they test positive with the Voges-Proskauer procedure.

Table 17.3 Gram negative beer spoilage bacteria (Van Vuuren, 1999)

Bacterial type	Description	Effects of growth in brewing process
Acetic acid bacteria – <i>Acetobacter</i> <i>A. aceti</i> <i>A. liquefaciens</i> <i>A. pastorianus</i> <i>A. hansenii</i>	Slightly curved or straight rods up to 4 μm in length. Cells are pleomorphic and occur in pairs or chains. Some species are motile obligate aerobes and catalase positive. Capable of oxidizing ethanol.	Form hazes or pellicles in beers containing oxygen. Products of metabolism include acetic acid and acetate.
Acetic acid bacteria – <i>Gluconobacter</i> <i>G. oxydans</i>	Similar morphology to <i>Acetobacter</i> . Obligate aerobes, catalase positive, ethanol is oxidized to acetic acid. Ethanol is not oxidized.	As for <i>Acetobacter</i> .
<i>Zymomonas</i> <i>Z. mobilis</i>	Short fat rods, which occur singly, in pairs, chains or rosettes. No endospores are formed. Some species are motile others are not. They grow anaerobically but are catalase positive and tolerate aerobiosis. Glucose and fructose (but not maltose) are fermented to form ethanol. The optimum growth temperature is 25–30 °C.	Exclusive to ale breweries where spoilage causes ‘rotten apple’ flavour due to the formation of hydrogen sulphide and acetaldehyde.
<i>Obesumbacterium (Hafnia)</i> <i>O. proteus</i>	Short, fat, pleomorphic rods. They are catalase positive and ethanol tolerant. Growth in wort produces dimethyl sulphide, higher alcohols and diacetyl. Nitrate or nitrite are reduced to form carcinogenic nitrosamines.	Contaminant of pitching yeast which, if present, grows with yeast during fermentation and results in slow attenuation rates and high pH beer. Gives rise to fruity/parsnip off-flavours.
<i>Citrobacter</i> <i>C. freundii</i>	Slender straight rods occurring singly or in pairs and usually motile. Cells are catalase positive and are facultative anaerobes. Citrate is used by most but not all species. Glucose is fermented to form mixtures of organic acids (lactate, pyruvate, isocitrate and succinate). Relatively ethanol intolerant.	Rare contaminant in fermentations where it causes accelerated attenuation rate and produces increased organic acids and DMS. They are killed in late fermentation by the presence of ethanol.

Enterobacter (Rahnella)
R. aquatilis
E. agglomerans

Short squat rods, which may be motile. Glucose is fermented to produce acid and gas. Strains are positive in the VP test (Table 17.2).

In the brewing process it behaves in a similar manner to *Obesumbacterium* and is a contaminant of pitching yeast. It is relatively intolerant to ethanol and survives more readily in top cropping ale fermentations. Abnormally high diacetyl levels are produced in contaminated worts.

Klebsiella
K. terrigena
K. oxytoca

Slender straight capsulated, non-motile rods occurring singly or in short chains. They are facultative anaerobes and ferment glucose to produce acid and gas.

Ferulic acid in wort is decarboxylated to produce 4-vinylguaiacol. This imparts a phenolic off-flavour to beer. The reaction is also catalysed by some wild yeasts.

Pectinatus
P. cerevisiiphilus

Very slender curved rods occurring singly or in pairs. Older cells are elongated. They are motile and obligately anaerobic.

Contaminants of small-pack beers where oxygen levels are low. Produces hydrogen sulphide and other sulphur compounds.

Megasphaera
M. cerevisiae

Obligately anaerobic slightly elongated non-motile and non-spore forming cocci occurring singly or in short chains. They are relatively ethanol intolerant.

Spoilage is restricted to low oxygen environments where the ethanol concentration does not exceed c. 4% v/v. Putrid aromas and tastes occur due to the formation of hydrogen sulphide and other sulphur-containing metabolites.

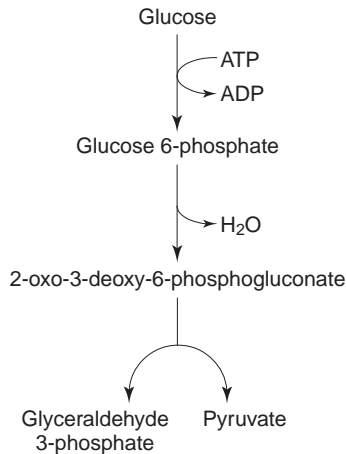

Fig. 17.2 The Entner-Duodoroff Pathway.

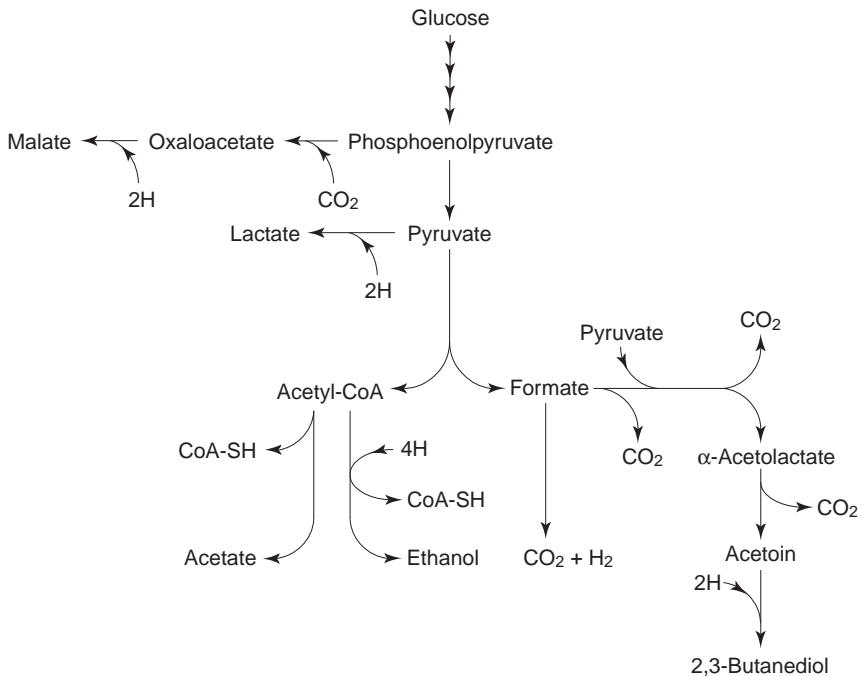

Fig. 17.3 Glucose metabolism by bacteria belonging to the genus *Enterobacteriaceae* (redrawn from Van Vuuren, 1999).

Indole-negative *Klebsiella* strains produce phenolic off-flavours in beers as a consequence of the formation of 4-vinylguaiacol via the decarboxylation of ferulic acid. The latter is a phenolic acid present in wort and the reaction is similar to that which is catalysed by some wild yeast infections. The increased concentration of dimethyl sulphide (DMS) associated with many *Enterobacteriaceae* infections does not derive from the degradation of sulphur-containing wort amino acids (Wainwright, 1972). In the case of *R. aquatilis*, DMS was formed via the reduction of dimethyl sulphoxide (McCaig and Morrison, 1984).

Of all the Gram negative beer spoilage bacteria, *Obesumbacterium proteus* poses the greatest risk to the brewing process as a result of its role in the formation of N-nitrosamines (Smith, 1994). These compounds are powerful animal carcinogens. Non-volatile N-nitrosamines (apparent total N-nitroso compounds, ANTC) are formed by reactions between wort amines and nitrite. Nitrate is present in all worts and *O. proteus* is capable of reducing it to nitrite thereby providing the precursor for ANTC formation. The ability of *O. proteus* to grow in wort and survive into the yeast crop has necessitated the introduction of procedures for ensuring that it is eliminated before re-pitching. The process of acid washing, in which pitching yeast is subjected to controlled acidification, accomplishes this. Disinfection of pitching yeast by acid washing relies upon the relative tolerance and sensitivity of yeast and bacteria, respectively to low pH (see Section 17.6).

Zymomonas mobilis tolerates oxygen but grows under anaerobic conditions. It ferments glucose and fructose but not maltose. Unlike most of the *Enterobacteriaceae* it tolerates ethanol and reportedly survives high-gravity fermentations in which 12–13% v/v ethanol are formed (Magnus *et al.*, 1986). It has a relatively high optimum growth temperature of 25–30°C. For this reason, it tends to be a more common spoilage bacterium in ale breweries as opposed to those fermenting lager worts at lower temperatures. Infected worts develop a characteristic rotten apple odour due to the formation of acetaldehyde. In addition, ethanol, acetic acid, lactic acid, acetoin and glycerol are formed (Van Vuuren, 1999). The formation of and high tolerance to ethanol has made *Zymomonas* the organism of choice for many industrial alcohol production processes. This fact emphasizes the threat that the organism poses to brewing.

The Gram negative cocci, *Megasphaera* spp. and the Gram negative rods, *Pectinatus* spp. are contaminants of beer. They are tolerant of hop resins but their potential for spoilage is limited by virtue of their absolute requirement for anaerobiosis. For this reason they tend to be found in finished beers. *Megasphaera* strains produce several organic and fatty acids, notably butyric acid and some acetic, isovaleric and valeric. In addition, hydrogen sulphide is generated (Engelmann and Weiss, 1985). Their potential for beer spoilage is restricted by their sensitivity to ethanol (> 2.8% v/v) and acid pH (Haikara and Lounatmaa, 1987). It is considered that unpasteurized, low-alcohol beers are most prone to spoilage by *Megasphaera*. Nevertheless, several weeks may be required before turbidity becomes evident.

Pectinatus strains are also obligate anaerobes but are more tolerant of ethanol. Their presence in pitching yeast has been reported (Haikara, 1989) but infection of beer via this route is of very rare occurrence. Spoilage of beer by *Pectinatus* results in the formation of high concentrations of hydrogen sulphide with its putrid odour and development of turbidity. Various fatty acids, especially propionic and acetic, together with some acetoin are also produced.

17.3.4 Gram positive beer spoiling bacteria

Gram positive bacteria associated with beer spoilage are either rods or cocci, which together are termed the lactic acid bacteria. In addition, some members of the genera *Bacillus* and *Micrococcus* have been isolated from beers, although their status as true spoilage bacteria is questionable. Nevertheless they are included for completeness (Table 17.4). Apart from their reaction to the Gram stain this group of spoilage bacteria is distinguished from Gram negative types in that they are on average less resistant to the antiseptic effects of hop resins. However, this distinction is not absolute and there is

Table 17.4 Gram positive beer spoilage bacteria (Priest, 1999)

Bacterial type	Description	Effect on brewing process
<i>Lactobacillus</i> <i>L. brevis</i> <i>L. casei</i> <i>L. plantarum</i> <i>L. fermentum</i> <i>L. buchneri</i> <i>L. delbrückii</i>	Slender non-motile anaerobic rods that do not form endospores. They lack catalase but can tolerate oxygen and low pH. Some strains are resistant to hop resins. They usually have fastidious nutritional requirements. Fermentative growth produces mainly lactic acid (homofermentative types) or mixtures of lactic acid, acetic acid, ethanol and carbon dioxide (heterofermentative types).	Produce turbidity in infected beers. Some strains produce extracellular polysaccharides, which appear as visible 'ropes' in infected beer. Sour/acid off-flavours are generated.
<i>Pediococcus</i> <i>P. damnosus</i> (syn. <i>P. cerevisiae</i>) <i>P. inopinatus</i>	Gram positive non-motile cocci occurring singly, in pairs or as tetrads/short chains. Originally they were known as sarcinae, although aggregates of eight cells are rare. They are catalase negative but can tolerate some oxygen and grow under microaerophilic conditions. Most strains are homofermentative and many are resistant to hop resins. They are ethanol tolerant.	Spoilers of fermenting worts and beers where they produce hazes, acidity and high concentrations of diacetyl. Historically, the latter was referred to 'sarcina sickness'.
<i>Bacillus</i> <i>B. coagulans</i>	Large motile rods which form endospores. They are catalase positive and aerobic/facultatively anaerobic. They are thermoduric and thermophilic but sensitive to hop resins and cannot grow in media with a pH lower than c. 5.0.	The endospores allow them to survive wort boiling. They are able to grow in hot (55–70 °C) sweet wort where they produce lactic acid. They are inhibited by hop acids and low pH and do not cause beer spoilage.
<i>Micrococcus</i> <i>M. kristinae</i>	They are catalase positive and usually obligate aerobes (<i>M. kristinae</i> is a facultative anaerobe). They are sensitive to acid pH and hop resins.	Common contaminants in breweries but their sensitivity to hop resins and intolerance of acid pH prevent beer spoilage.

significant variability. Thus, some members of the lactic acid bacteria are resistant to hop resins, whereas *Micrococcus* and *Bacillus* spp. are sensitive.

The lactic acid bacteria are an important group. Apart from having the potential to spoil foods they are used industrially to make fermented dairy products such as yoghurt. Others are of clinical significance. A review of these bacteria may be found in Priest (1999). The genus *Lactobacillus* contains members that are genetically diverse and further revision and sub-division is likely. Original classifications were based upon the mode of fermentative growth and temperature relations. Heterofermentative types were placed within the *Betabacterium* genus. Homofermentative types were subdivided into thermophilic strains (*Thermobacterium*) and mesophilic strains (*Streptobacterium*). These groups are still mentioned but do not have taxonomic significance.

Lactococcal bacteria are classified into several genera. Historical classifications placed many of them into the *Streptococci* on the basis of facultative anaerobiosis and homofermentative physiology. These have now been sub-divided into the *Streptococcus sensu stricto*, *Enterococcus* (indicators of faecal contamination, includes *S. faecalis*), *Lactococcus* (includes the dairy types, *S. lactis*), *Vagococcus* (motile types resembling *Lactococcus*). Heterofermentative cocci occurring in pairs or short chains are now classified as *Leuconostoc*. Homofermentative cocci that divide in two planes to produce pairs or tetrads are classified as *Pediococcus*.

Beer spoilage by lactococcal bacteria is restricted to *Pediococcus*, the most common species being *P. damnosus*. This bacterium is found commonly as a contaminant of wort and beer. It is not found in brewing raw materials (Priest, 1999), suggesting that it is particularly well adapted to the environment of the brewery. A second species, *P. inopinatus*, has also been isolated from breweries but is also found in non-brewing habitats. *P. inopinatus* has been isolated from pitching yeast but rarely from beer. Of the two species, *P. damnosus* is the more resistant to hop resins and it persists through fermentation into finished beer.

The potential for *Lactobacillus* to spoil beer is dependent upon the relative sensitivity of individual strains to hop resins. Simpson and Fernandez (1992) determined the minimum concentration of *trans*-isohumulone required to inhibit the growth of 42 strains of *Lactobacillus*. The bacteria could be classified into three groups; sensitive types inhibited by 20 μM *trans*-isohumulone, an intermediate group in which the minimum inhibitory concentration was 20–40 μM and a third group capable of growth in the presence of up to 180 μM *trans*-isohumulone. Only the third group could be isolated from beer. In a later paper (Simpson and Fernandez, 1994), the same authors concluded that resistance to at least 90 μM *trans*-isohumulone was necessary for *Lactobacillus* strains to qualify as beer spoilers. Resistance to hop resins is pH dependent. Simpson (1993) reported that increase in pH decreases the toxic effect of hop iso- α -acids. In the author's view, an increase in pH of as little as 0.2 units could reduce the protective effect of hop resins by as much as a half.

Confirmation that *Lactobacillus* strains are beer spoilers is notoriously difficult to demonstrate since usually they will not grow on beer. Cultivation may be facilitated by successive pre-incubation of strains in media containing increasing proportions of beer. Similar results are obtained if the beer is substituted with 45 μM *trans*-isohumulone (Simpson and Fernandez, 1992). This training procedure is time consuming. A more rapid approach has been developed in which MRS medium is supplemented with 20 μM *trans*-isohumulone (Simpson and Hammond, 1991). This medium suppresses the growth of non-beer spoiling *Lactobacillus* strains but permits the growth of those capable of spoilage. The ability of some strains to tolerate hop resins is probably a consequence of

the possession of a plasmid-borne gene, termed *hor A*. Thus, Sami *et al.*, (1997a) demonstrated that of 61 strains containing *hor A*, only two could not grow in hopped beer. Similarly, only one out of 34 *hor A* negative strains grew in beer. The same group has proposed that rapid identification of beer spoiling *Lactobacillus* strains is possible via detection of *hor A* using PCR DNA technology. From a taxonomic standpoint, at least nine species of *Lactobacillus* have been isolated from beer (Sami *et al.*, 1997b). Those most commonly encountered are *L. brevis*, *L. casei*, *L. curvatus*, *L. plantarum* and *L. delbrückii*.

Infections of beer by *Pediococci* are characterized by the formation of high concentrations of diacetyl, accompanied by a reduction in yeast growth and low fermentation rates. Historically, this was called sarcina sickness, a reference to the similarity between *Pediococci* and true octuplets of *Sarcina* spp. Extracellular thixotropic polysaccharide slimes may also be formed resulting in the formation of visible 'rope'. Infections by *Lactobacillus* produce similar symptoms to *Pediococcus*. Growth in beer produces 'silky turbidity'. Rope may be formed by some strains. As with *Pediococcus* acid is produced although the most noticeable flavour defect is the formation of diacetyl. All lactic acid bacteria rely on the small concentrations of nutrients available in beer for their growth. The presence of priming sugars, such as sucrose or fructose, provides a readily assimilable source of sugar. In the absence of simple sugars, maltotriose and maltotetraose may be utilized by some strains. *L. diastaticus*, now not considered to be a separate species and placed within *L. brevis*, is capable of utilizing dextrans. As its name suggests it has the potential to produce superattenuation of worts during fermentation.

Lactic acid bacteria are catalase negative anaerobes. They do not possess superoxide dismutase (Archibald and Fridovich, 1981). Since they lack these standard mechanisms for nullifying the toxic effects of reactive oxygen radicals, it is surprising that they can tolerate exposure to oxygen. In fact, they use a combination of NADH oxidases and a pseudocatalase for removing peroxide ions (Johnston and Delwiche, 1965). Superoxide radicals are apparently scavenged by high intracellular concentrations of Mn^{2+} .

In homofermentative strains (*Pediococcus* spp., *L. casei*, *L. plantarum* and *L. delbrückii*) the major product of sugar metabolism is lactic acid. In this group sugars are metabolized via glycolysis. Pyruvate, derived from glycolysis, is reduced to lactate via the action of NADH-linked lactate dehydrogenase. Heterofermentative strains (*L. brevis*) produce a mixture of end products, including lactate, glycerol, ethanol and acetate. These strains utilize the phosphoketolase pathway, in which, glucose catabolism proceeds via 6-phosphogluconate which, following a decarboxylation reaction, forms the pentose sugar, xylulose 5-phosphate. These reactions are those that form the initial part of the hexose monophosphate shunt (Section 12.5.2). Apart from this being an alternative to glycolysis, it provides a route by which pentoses can be catabolized. Phosphoketolase catalyses the cleavage of xylulose 5-phosphate to yield, after the addition of another phosphate group, a molecule of triose phosphate and one of acetyl phosphate. From these intermediates glycerol, acetate, ethanol and pyruvate are formed (Fig. 17.4).

The formation of diacetyl by lactic acid bacteria contamination during fermentation does not exclusively use the same pathway as that employed by brewing yeast. In yeast, diacetyl derives from the spontaneous oxidative decarboxylation of α -acetolactate. Diacetyl is then reduced to acetoin and 2,3-butanediol (Section 12.10.2). In lactic acid bacteria, the same sequence of reactions can occur but some strains also possess α -acetolactate decarboxylase, which produces acetoin directly, without the intermediary of diacetyl. A second route also operates in which diacetyl is synthesized directly from the

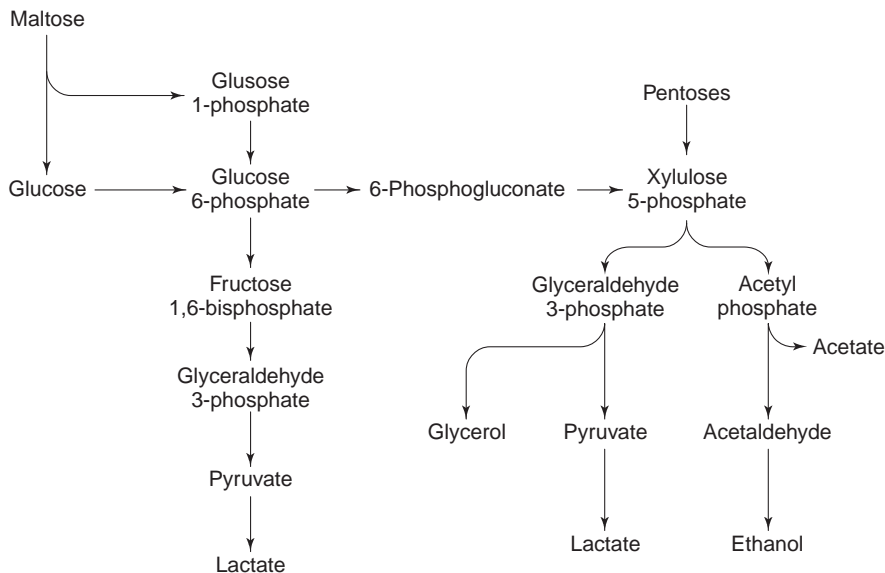

Fig. 17.4 Homofermentative and heterofermentative sugar metabolism in lactic acid bacteria (for details see text).

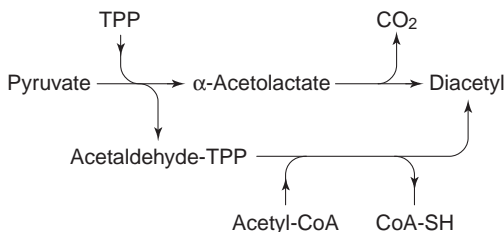

Fig. 17.5 Pathways for the formation of diacetyl by lactic acid bacteria.

activated form of acetaldehyde (acetaldehyde thiamine pyrophosphate) and acetyl-CoA (Speckman and Collins, 1973; Fig. 17.5).

17.3.5 Beer spoilage yeasts

Spoilage by yeasts is potentially a serious problem since many such contaminants are capable of occupying the same ecological niche as production strains. However, since they have different genotypes from the production strain their activities can produce a variety of defects in process and product. Traditionally, contaminants are referred to as wild yeasts. The concept of 'wildness' is imprecise. Thus, contaminants may range from non-*Saccharomyces* yeast strains through to accidental mixing of production brewing strains. In the latter case, the mixing of ale and lager strains can be especially problematic. A good working definition of wild yeast is any yeast not deliberately used and under full control (Gilliland, 1971). This all-embracing definition allows for all possibilities, from the use of pure monocultures through to those rare fermentations that rely on spontaneous contamination. The similarity of wild yeasts to production strains can make them difficult to detect. Although their presence may be signalled by major changes

to product and process, it is equally possible that much less apparent and subtle defects can be caused. Acid washing of pitching yeast, which reduces bacterial contamination is not effective with wild yeast. Avoidance of contamination by yeast is entirely dependent upon the maintenance of high standards of hygiene.

Beer spoilage yeasts may be considered as *Saccharomyces* and non-*Saccharomyces* types. The *Saccharomyces* wild yeasts pose the greatest threat since they are most similar to production strains. *Ipso facto*, they have the ability to colonize the same range of habitats as production yeast strains. Their similarity to production strains makes differentiation difficult. The taxonomic classification of *Saccharomyces* beer spoilers is now of little practical significance in that many strains originally given the status of species, based on characteristics of relevance to spoilage, have now been assigned to *S. cerevisiae*. The discussion in this section will be confined to a description of the effects of contamination. Species names will be used only to provide a historical context. The effects of inadvertent mixing of production strains are difficult to predict. Some likely outcomes are changes in flavour, cropping behaviour, fining behaviour and attenuation rate and extent. These are immediately obvious changes. More subtle changes from the norm, particularly if the level of contamination is low, may be much more difficult to detect, especially if there is a gradual change in the level of contamination with successive fermentations.

More dramatic defects are caused by contamination with specific *Saccharomyces* yeasts. Certain *Saccharomyces* strains and some members of the genera *Kluyveromyces*, *Pichia* and *Williopsis* synthesize so-called killer factors. These are toxins, also known as zymocins that have no effect on the producing strain but are rapidly lethal to other susceptible strains of the same species (Young, 1987; Magliani *et al.*, 1997). Some zymocins are ionophores. They exert their lethal effects by disrupting the plasma membrane of target cells such that their ability to retain ions is destroyed. Others inhibit DNA synthesis.

Contamination of fermentations with killer yeast has the potential for catastrophic disruption of the brewing process. They appear to be rare in breweries. In a survey of 964 species, representing 28 genera, 59 were found to produce killer factors. Of these, more than half were *Saccharomyces* strains (Sami *et al.*, 1997a). Most of these were laboratory haploids and only four were brewing types (Philliskirk and Young, 1975). Occasional infections with killer yeast of an early continuous primary fermentation system were reported by Maule and Thomas (1973). The problem was severe, since infection levels of less than 3% of the total yeast population were sufficient to virtually eliminate the production strain.

Killer factors might be harnessed for a useful purpose. An early proposal was to genetically modify brewing strains by the introduction of a killer factor (Hammond and Eckersley, 1984). The use of a 'killer' brewing yeast strain would be an aid in the prevention of contamination. This option has not been pursued since brewers will not use genetic engineering. No doubt that it is an interesting approach but it would never be a substitute for good hygiene. In addition, it might be a risky strategy where several yeast strains are used within the same brewery.

Most brewing strains are unable to utilize dextrans and these persist in beer where they contribute to fullness and mouth-feel. Some strains, originally classified as *S. diastaticus* but now placed with *S. cerevisiae*, possess glucoamylase and in consequence can utilize dextrans. Contamination of fermentations with diastatic yeasts leads to superattenuation of the wort and beers with abnormally low present gravity. Occasionally, diastatic yeasts have been used to produce so-called 'light' beers. However, such strains commonly

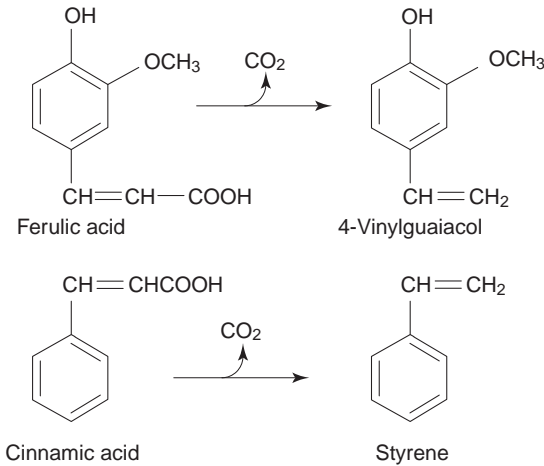

Fig. 17.6 Formation of 4-vinylguaiacol from ferulic acid and styrene from cinnamic acid by wild yeast possessing the phenolic off-flavour (POF) gene.

possess other, undesirable characteristics. The removal of dextrans is more usually accomplished by the direct addition to wort of preparations of glucoamylase (amyloglucosidase). Contamination of unpasteurized bottled beer with diastatic yeast is potentially hazardous, since abnormally high concentrations of carbon dioxide can develop with the consequent risk of bottle explosions.

Many diastatic yeast strains possess a gene termed POF, an acronym for phenolic off-flavour (Ryder *et al.*, 1978). This gene encodes for the enzyme phenolic acid decarboxylase. This enzyme decarboxylates wort phenolic acids such as ferulic and cinnamic acids to produce 4-vinyl guaiacol and styrene (Fig. 17.6). These compounds impart a medicinal or clove-like taste and aroma. They are an essential part of the flavour of some beers, for example, many wheat beers. In most cases the presence of these compounds is a serious defect.

Many non-*Saccharomyces* yeasts are routinely found in breweries. Most cannot compete with brewing yeasts and hence do not usually gain a foothold within the process. Many potential contaminants are not particularly tolerant of ethanol, few are able to ferment sugars and many cannot grow under anaerobic conditions. Their relatively poor adaptation to brewing conditions means that the threat they pose is small. Spoilage by non-*Saccharomyces* yeast is generally restricted to some raw materials and to the aerobic phase of fermentation. More opportunities for spoilage occur in licensed premises. Ales in cask and dispense systems used for all draught beers can provide a semi-aerobic environment in which many non-*Saccharomyces* yeasts can grow. In this sense these yeasts are opportunistic contaminants which flourish where poor hygiene and bad practice combine to provide the conditions for growth. Scrupulous cleaning of dispense equipment and prevention of air ingress into casks by dispensing under blankets of inert gas minimize the risks.

Non-*Saccharomyces* yeasts encountered in both the brewery and licensed premises include representatives of the following genera. *Cryptococcus* and *Rhodotorula* are commonly detected but unless conditions are grossly atypical are not able to spoil wort or beer. *Candida*, *Kluyveromyces*, *Pichia* and *Torulaspora* are opportunistic spoilers during the aerobic phase of fermentation and in unpasteurized cask beers. Most are obligate aerobes although *Candida* and *Torulaspora* are capable of poor growth under anaerobic

conditions. Strains of *Pichia* which colonize cask ales maximize their opportunity for utilizing any oxygen in the gas space by forming surface films. *Zygosaccharomyces*, especially *Z. bailii* and *Z. rouxii* are osmotolerant strains and can cause spoilage of bulk sugar syrups. Of all the non-*Saccharomyces* yeasts, *Brettanomyces* and *Dekkera* probably pose the greatest threat to unpasteurized beers. Both are able to ferment sugars to form ethanol, however oxygen stimulates fermentation, (Custers effect, Section 12.5.8). Beer spoilage by these strains is characterized by the formation of high concentrations of acetic acid.

17.3.6 Microbiological media and the cultivation of micro-organisms

In order to cultivate micro-organisms in the laboratory it is necessary to provide favourable growth conditions and it may also be important to control conditions such that they are inimical for organisms whose growth is not desired. This requires the provision of a suitable source of nutrients, possibly the addition of growth inhibitors and control of the physical environment.

The key environmental parameters are temperature and gas supply. The former is regulated by the use of thermostatically controlled microbiological incubators. Maintenance of temperature to $\pm 1^\circ\text{C}$ within a range of ambient to 55°C is usually adequate. In many instances cultivation at room temperature ($18\text{--}25^\circ\text{C}$) is sufficient. The gas supply is controlled to differentiate between aerobes and anaerobes. For aerobic cultures incubation is in the presence of air. For liquid cultures it may be necessary to improve oxygen transfer from the air to the growing micro-organisms by incubating on devices which shake the culture flask. Commonly, flask shakers and thermostatically controlled incubators are combined into a single piece of apparatus. For larger volume liquid cultures, where shaking is not practicable or efficient, air or oxygen can be introduced by bubbling gas into the medium through a sinter or candle fitted with a sterile filter. The provision of mechanical stirring further improves gas transfer rates.

Maintenance of anaerobic conditions requires specialized equipment. Typically, this is a jar in which solid or liquid cultures are placed. Air can be removed by evacuation or by replacement with an inert gas such as nitrogen. Visual confirmation of anaerobiosis is provided by incorporation of a solution of methylene blue, which is colourless in its reduced form. Early devices relied on flushing out air with hydrogen and removing the final vestiges of oxygen via combustion using a platinum catalyst. Modern approaches use commercially available kits that remove oxygen chemically. Typically, these are added to an anaerobic jar and activated by the addition of water. For example, one such kit contains sodium borohydride and sodium bicarbonate. Addition of water generates hydrogen and carbon dioxide, which flushes out air. For incubation of one or a small number of plates, these kits are available as self-contained re-sealable foil pouches containing deoxygenating chemicals. Enrichment of the atmosphere within an anaerobic culture with carbon dioxide promotes the growth of many organisms, for example, lactic acid bacteria. The choice of solid or liquid medium depends upon the application. Liquid media are often used for the production of pure cultures, as with yeast propagation (Section 13.5.2). They are useful where the yield and growth rate must be maximized. Solid media are useful for characterizing microbial populations. They consist of a nutrient medium solidified with agar or gelatin. Normally the medium is held in a Petri dish (Prescott *et al.*, 1996).

Solid media serve several useful purposes. Microbiological samples can be plated out such that individual cells are separated from their neighbours. During incubation colonies

develop and it may be assumed that each derives from a single cell. Counting colonies allows enumeration of the microbial population within the sample. The appearance of the colonies often has diagnostic significance. Incorporating components into media that alter the appearance of some colonies and not others, depending on the identity of the micro-organism, can enhance this. In this way plate cultures can be used to check that cultures are pure. Conversely, they can provide visual indication that the microbial population in the original sample was mixed. Separation of mixed populations into distinct colonies facilitates subsequent purification by allowing removal of chosen colonies and transfer to fresh medium.

General-purpose media are designed to support the growth of many different microbial species. They are useful for detecting heterogeneous populations and may be used to assess total microbial loadings in particular locations. Commonly these are complex media that contain nutrients that many micro-organisms are able to utilize. Complex media are not chemically defined. Usually they contain one or more components, which are general sources of amino acids, proteins, vitamins and metal ions. These are supplemented with specific sources of carbon such as sugars. Examples of general base ingredients are yeast extract, peptone and clarified meat extracts. Some complex media are tailored to a particular application. For example, in brewing several media formulations include wort or beer.

Selective media are formulated to promote the growth of certain groups of micro-organisms but not others. They are used in conjunction with selection via control of the environment, such as manipulation of temperature and provision or exclusion of oxygen. Selective media are used in many ways. Defined media contain only identified and often chemically simple components in combinations that support the growth of some micro-organisms but not others. Media can be made more selective by the incorporation of inhibitors. These can be very general purpose, for example, the addition of selected antibiotics that inhibit yeast but allow the growth of bacteria, such as might be used in the assessment of contamination. Other inhibition protocols might prevent the growth of many bacteria but allow the growth of yeast. For example, making media acid ($< \text{pH} 4.0$) prevents the growth of many bacterial species but allows yeast to grow. Other selective pressures are more focused, for example, supplementation of media with Cu^{2+} ions inhibits the growth of most brewing yeasts but allows the growth of many wild yeast strains.

Many different media have been designed for use in brewing microbiology (European Brewery Convention, 1998; Institute of Brewing, 1997; American Society of Brewing Chemists, 1992; Bridson, 1998). Some of these are described in Table 17.5. In many cases there are several media available and there is little consensus as to which are the best. Personal preference and experience is the final arbiter. Commonly, modifications are made to media to suit the needs of particular breweries. For example, the concentration of copper needed to suppress brewing strains but allow the growth of wild yeast varies with individual strains.

Media can be assured by using positive and negative control micro-organisms, which should or should not grow. Poor technique can result in false positive results if plates are contaminated during handling. The competence of brewing microbiological laboratories can be subject to independent assessment. In the United Kingdom there is a proficiency testing scheme (BAPS Microbiology) run by the Laboratory of the Government Chemist in conjunction with Brewing Research International (BRi). Blind samples are supplied to participating laboratories. These are subjected to qualitative and quantitative analysis using routine microbiological analyses. Since all participants receive the same samples

Table 17.5 Some microbiological media used in brewing laboratories (Bridson, 1998)

Medium	Application	Comments
MYPG	General-purpose medium for yeast and bacteria.	Malt extract, yeast extract, peptone, glucose.
Nutrient agar/broth	General-purpose medium for bacteria although many yeasts will also grow.	Contains yeast extract, peptone, NaCl and Lab-Lemco (clarified meat extract). Acidification with HCl to pH 4.0 suppresses growth of many bacteria.
WLN (Wallerstein Laboratory nutrient medium)	General-purpose medium for yeast but many bacteria will also grow.	Incorporates pH indicator, bromocresol green which allows differentiation of some yeast strains from the colour of colonies.
MYPG – copper	Wild yeast, both <i>Saccharomyces</i> and non- <i>Saccharomyces</i> .	Addition of hydrated copper sulphate (200 mg.l ⁻¹) prevents growth of brewing yeast.
WLD (Wallerstein Laboratory Differential)	General-purpose medium for bacteria.	Addition of cycloheximide (15 mg.l ⁻¹) suppresses growth of brewing and some wild yeast. Addition of isomerized hop extract (400 mg.l ⁻¹) suppresses growth of spore-forming bacilli.
Lysine medium	Selective medium for non- <i>Saccharomyces</i> wild yeasts.	Synthetic medium in which lysine is the principal source of nitrogen.
Crystal violet medium	Selective medium for some wild yeasts.	Crystal violet (20 µg/ml ⁻¹) suppresses the growth of brewing yeast, variable with others.
Yeast nitrogen base	Carbon assimilation medium for yeast.	Minimal medium to which various carbon sources are added.
Potato dextrose agar	General-purpose medium for yeasts and moulds.	Contains glucose and potato extract.
Hopped wort agar	General-purpose medium for yeasts, suppresses growth of some Gram positive bacteria.	Hopped (1040) wort solidified with agar.
Yeast morphology agar	Assessment of yeast colonial morphology.	Complex defined medium.

Melibiose medium	Differential medium for ale and lager strains.	Only lager strains grow.
Frateur's medium	Differential medium for <i>Acetobacter</i> and <i>Gluconobacter</i> spp.	Contains yeast extract, ethanol and calcium carbonate. <i>Acetobacter</i> colonies produce clearing due to acid formation from ethanol. <i>Gluconobacter</i> deposit chalk round clearing due to continued growth on ethanol with formation of CO ₂ .
Carr's medium	Differential medium for <i>Acetobacter</i> and <i>Gluconobacter</i> spp.	Contains yeast extract, ethanol and bromocresol green. <i>Acetobacter</i> strains produce acid, <i>Gluconobacter</i> strains degrade acid following prolonged incubation.
Dadd's and Martin's Medium	Medium for isolation of <i>Zymomonas</i> spp.	Glucose, yeast extract, peptone supplemented with ethanol (3% v/v) and cycloheximide (50 mg l ⁻¹). Adjust to pH 4.0 with HCl.
MRS (Man, de Rogosa, Sharpe medium)	Selective medium for lactic acid bacteria.	Buffered peptone, Lab-Lemco. glucose, plus Mg ²⁺ , Mn ²⁺ . Made selective by the addition of 2-phenylethanol and cycloheximide. Modified MRS contains maltose, MRS + beer makes medium more suitable for application in brewing.
Raka-Ray	Recommended selective medium for lactic acid bacteria.	Yeast extract, tryptone, liver concentrate, maltose, fructose, glucose, metal salts. Supplemented with sorbitan mono-oleate, cycloheximide and 2-phenylethanol.
NBB (<i>Nachweismedium für Bierschädliche Bakterien</i>)	Selective medium for lactic acid bacteria.	Buffered glucose, maltose, peptone, yeast extract, meat extract. Supplemented with beer and an indicator, chlorophenol red.
Pre-reduced PYG agar	Detection of <i>Megasphaera</i> .	Peptone, yeast extract, glucose medium which is autoclaved and placed in anaerobic jar whilst still molten. Allowing agar to set in anaerobic conditions maintains reducing conditions.

comparative assessment of results is possible. Successful analysis of the test samples confirms that brewery laboratories are able to recover, cultivate and identify typical brewery contaminants.

17.4 Microbiological quality assurance

Traditional microbiological analyses do not easily fit into a conventional quality control system. Analyses based on sampling, plating and incubation require three to seven days to yield results. This is too long. Packaged product must be dispatched to trade as quickly as possible and with a minimum of stock holding. On the other hand, the brewery must ensure that product is wholesome and will not deteriorate during its intended shelf-life. There is an obvious correlation between poor quality and lost sales. From a broader perspective, brewers have an obligation to exercise due diligence and guarantee the harmlessness of their products.

The time lag between sampling and result means that product may have reached the consumer before problems become evident. Fortunately, beers do not support the growth of pathogens. However, the economic implications of a major product recall could be catastrophic. To counter this threat there has been a move towards systems quality assurance. Quality control (QC) is based upon sampling the final product and ensuring that specifications are achieved before dispatch. Quality assurance (QA) ensures that production systems are sufficiently robust that product quality and integrity are guaranteed. In other words, quality systems are designed to be preventative rather than based on inspection. Most brewers use a hybrid of QC and QA. This is partly a consequence of the conservatism of the brewing industry. From a microbiological standpoint, QA guarantees the integrity of product and therefore eliminates the requirement for final product testing. Most brewers accept this argument but prefer to follow a more visceral approach and demand an apparent clean bill of microbiological health for finished product.

Microbiological quality assurance systems consist of a number of essential elements. The process is divided into separate defined sub-processes. A sample plan is constructed for each sub-process. This considers where samples should be taken, what their size and frequency should be and what analyses should be performed on them. Results of analyses must be judged against appropriate specifications. A permanent record of the results must be maintained. Results are linked with individual batches of product, since there must be full traceability throughout the entire process from raw materials to finished product.

Complex processes such as brewing require the use of formal quality systems, which are subject to external and independent accreditation. Commonly, the ability to operate to the ISO 9000 quality standard is used within the UK brewing industry. Such systems ensure product wholesomeness and also satisfy food safety legislation, for example the European Food Hygiene Directive and United Kingdom Food Safety Act (White, 1994). Within the quality systems, the formal assessment and management of risks is achieved using HACCP analysis (hazard analysis and critical control points). HACCP is integrated into the broader ISO 9000 system (Kennedy and Hargreave, 1997). It is a management system introduced to ensure food safety (Mundy, 1997). Usually it has been applied where processes present hazards to health from either physical or chemical agents. Microbiology has not usually been included except where there might be a health risk from pathogenic organisms. It is beginning to be used as a method of microbiological quality assurance where the risk is limited to product wholesomeness.

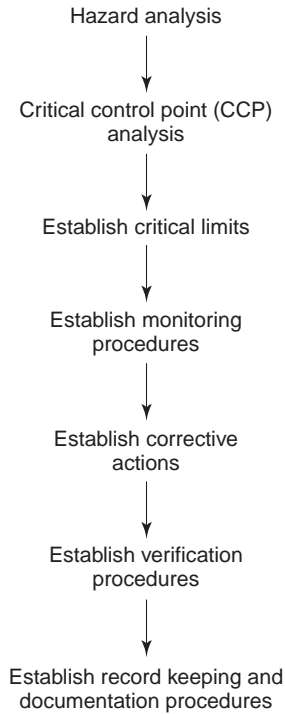

Fig. 17.7 Elements of HACCP analysis.

There are several elements to HACCP analysis. The starting point is to draw up a detailed flow diagram of the process under consideration. Once constructed, the process flow diagram must be verified to ensure that all relevant steps have been included. All HACCP analyses contain seven parts (Fig. 17.7). In the first part each step in the process is assessed and its inherent risks are identified. In the second step the identified risks are graded to identify those that are critical control points (CCPs). A CCP is a process step which, if not under proper control, has the potential to cause injury or illness to consumers. For microbiological control of the brewing process the concept of the CCP is widened to include a potential to result in the sale of product that is not wholesome. The third part of the analysis is to set critical limits for each CCP. For example, in the case of a pasteurized beer, the critical limits would be the time and temperatures needed to ensure that the product is rendered microbiologically stable.

The fourth step is to establish monitoring procedures to ensure that the critical limits are adhered to and the CCP is in control. In the case of the pasteurized product this would be a permanent record of the times and temperatures to which all batches of product had been exposed. The analysis of this type of step would include procedures to ensure the veracity of measurements, such as proof of calibration of thermometers. Monitoring should allow for the identification of trends where the CCP might be moving towards being out of control. Early identification of such trends allows corrective actions to be taken.

The fifth part of the analysis establishes corrective actions should a CCP be found to be out of control. To continue the example of the pasteurized product, this would include procedures to segregate product, which it was suspected might not have received the specified heat treatment. The procedures to be followed in these circumstances must be

detailed in the HACCP plan. They must happen and not be subject to discussion. In the example cited the first priority would be ensure that suspect product could not be sent to trade. The absolute requirement for reliable systems of traceability and labelling can be readily appreciated. Once suspect product has been isolated a more leisurely examination of the problem and consideration of its fate can be undertaken.

The penultimate step in the HACCP plan is to establish verification procedures. These are of several types and their precise nature depends upon the detail of the process. They must include two elements. Firstly, a day to day examination of the product to ensure that it meets pre-established specifications. Secondly, regular and preferably independent audits must be performed to guarantee the integrity of the process. Finally, the entire HACCP plan must be documented and a system of record keeping set up.

17.5 Sampling

An appropriate method must be used for obtaining a sample that is representative of the part of the process under investigation. The sampling device must operate in a manner that ensures that there is no contamination from the operator or from any other part of the process. The sample must be of an appropriate size to ensure that subsequent microbiological analyses yield significant results. Similarly, the frequency of sampling must be such that the microbiological quality of the process is assured. The results of analyses must be compared against predetermined specifications. Any results that fall outside a specified range must prompt investigations and where necessary cause corrective actions to be made. A record of results must be maintained for the purposes of traceability and for trend analysis.

17.5.1 Sampling devices

Sampling devices must be designed and used to ensure that each sample is taken in an aseptic manner. For permanent installations such as sample cocks that are fitted to vessels or process pipework, the design and location must be such that they are properly cleaned during CIP. Sample points should be in accessible locations. Prior to withdrawing the sample it must be possible to sterilize the internal and external surfaces of the device. This is best achieved by steam, but this is rarely available. Portable gas burners can be used to flame sample cocks, although care must be taken to avoid damage to rubber seals, etc. Where heat labile components are present external surfaces and internal components can be sterilized by flooding with a 70% v/v solution of methanol or industrial methylated spirits (IMS). IMS may be ignited (with care!) to facilitate sterilization. All apparatus used to collect samples, such as tubing and containers must be sterile and wrapped to prevent contamination.

Sample cocks are of three types. The safest is the diaphragm type. These consist of a port mounted flush into the surface of the tank or pipe. The port is sealed with a rubber membrane held in place by a stainless steel nut. The sample is withdrawn by piercing the membrane with a sterile hypodermic needle attached to a piece of sterile tubing. The sample is run into a suitable sterile container for transport to the laboratory. These sample ports must not be heated by flaming and the membrane must be sterilized by flooding with IMS. Membranes must be replaced regularly.

Plug-type sample cocks achieve a seal via a stopper containing a hole that can be rotated to align with the aperture in the sample port. A combination of good engineering and a thin layer of silicone-type grease achieves a watertight seal between the body of the

device and the stopper. Sterilization is achieved by a combination of heat and flooding with IMS. The outlet from the sampling device has a connection for a hose through which the sample is collected. The hose is the most microbiologically suspect part of the sampling device. Prior to use it must be sterilized by immersion in IMS.

Valve-type sample cocks have a screw thread mounted spindle that in the closed position seals the port. Unscrewing the spindle moves it outwards, unseals the port and allows liquid to flow. Typically, these sample cocks have two outlets mounted vertically to each other. Prior to sampling, the whole assembly is sterilized by passing steam through the top outlet and allowing the condensate to drain through the lower one. Again, care must be taken to ensure that contamination is not introduced from careless handling of hoses. Both plug- and valve-type sample cocks are suitable for withdrawing aseptic liquid samples of any volume. However, in the hands of the unskilled, they are more prone to result in contamination during sampling compared to diaphragm samplers.

Where comparatively large volumes must be sampled, because the expected microbial loading is low, it is convenient to use sterile membrane filters. The process liquid must not contain appreciable amounts of particulate material. Sample volumes are typically 1–5 litres. Usually membranes with a pore size of $0.45\ \mu\text{m}$ are used. They are placed within a filter holder which has appropriate fittings for attachment to the sample point. The membrane filter is attached, with the usual aseptic precautions, to a sample cock (either diaphragm- or valve-type). Typically a measured volume is allowed to pass through the membrane, but slowly, so as to avoid excessive gas breakout. Membranes are collected still in the holder, returned to the laboratory, removed and overlaid onto a plate containing a suitable solidified medium. Membranes are usually printed with a grid which, after incubation, facilitates counting of any colonies. By calculation the microbial count in the original sample is determined. This method can also be used for line drip tests where a small proportion of the process flow through a pipe is diverted so that it passes through a membrane, as described. Where very low, or zero counts are expected membranes may be left in place for several hours.

The membrane approach is used wherever there is a need to concentrate micro-organisms from a large volume of liquid or gas. Suitable apparatus is available for aseptic processing of liquid samples in the laboratory. This procedure is used for processing pasteurized and packaged beers. For example, keg/cask samples and whole bottles and cans. It can also be used for hygiene testing, for example, confirmation of CIP by testing of final rinse liquors, or saline rinse samples of steamed kegs. Rinse samples can be analysed using conventional microbiological techniques. More commonly, the ATP bioluminescence procedure is used (Section 17.3.1). Alternatively, the cleanliness of surfaces can be assessed by wiping with a sterile swab. Swabs are rinsed in sterile saline and any microbial contamination in the liquid assessed by conventional techniques or via bioluminescence.

Process gases such as CO_2 , N_2 , air or O_2 are sampled using bespoke apparatus such as the Hollandaer and Dalla Vale device. This consists of a sterilizable housing, which accommodates a 45 mm plate of nutrient medium. The device is attached aseptically to a suitable sampling point such that the gas is allowed to flow over the surface of the plate for a predetermined period of time. Plates are removed and incubated to detect growth. Results are expressed as colony forming units (cfu) per unit time. A criticism of the method is that prolonged gassing dries out plates and leads to underestimates of counts. This can be avoided by using gassing times of no more than 60 seconds. Alternatively, the sampling device can be replaced with an Ehrlenmeyer flask sealed with a bung through which pass inlet and outlet tubes. The latter is fitted with a sterile gas filter. The flask contains sterile saline solution and the gas flow to be sampled is allowed to bubble

through the liquid for a predetermined time. Microbial contamination is determined from samples of the saline plated out onto appropriate media.

Environmental microbial surveys should be performed to check loadings in sensitive areas such as packaging halls or cask racking plants. Atmospheric contamination can be assessed simply by exposing agar plates of appropriate media in the area of interest. Any organisms falling onto the plates that grow provide a measure of contamination. Apparatus designed for air sampling takes the form of a sterile housing in which a plate of nutrient agar medium is placed. The device, which is portable and hand held, draws a known volume of air across the surface of the plate. The plate is removed and incubated and resultant microbial colonies counted.

17.6 Disinfection of pitching yeast

Pitching yeast acts as a reservoir for low levels of bacterial contamination. Serial cropping and re-pitching provides a route for infection of successive fermentations. Providing the level of infection is low and the pitching yeast has high viability and vitality the effects on fermentation performance and beer quality will be small. However, as described in Section 17.3.3, the common contaminant of pitching yeast, *O. proteus*, has the ability to produce potentially carcinogenic nitrosamines from nitrite. To avoid this hazard it is common practice to disinfect pitching yeast prior to pitching.

Several approaches have been used to disinfect yeast each of which rely on agents that have the ability to selectively kill bacteria but not yeast. Obvious agents for this are antibiotics, which are used in an analogous manner in selective media. In two early studies (Gray and Kazin, 1946; Case and Lyon, 1956) it was demonstrated that thyrothricin and polymyxin B could be used to selectively kill bacteria in the presence of yeast. Superficially, the use of antibiotics is attractive. No effect on yeast would be expected, antibiotics are effective at low concentrations and their effect would persist into fermentation. However, this application of antibiotics was suggested at a time when the risks of selecting for resistant strains of bacteria were not appreciated. It is now recognized that introduction of antibiotics into foodstuffs is irresponsible and this practice has never been implemented. During the 1980s a brief resurgence of this approach took place. The use of a bacteriocin, nisin, was promoted as a bacterial disinfection agent for use in brewing (Ogden, 1987). Nisin is a small polypeptide synthesized by strains of *Lactobacillus lactis*. It exerts its toxic effects by disrupting the membranes of susceptible cells. It is used in many food industries, particularly those producing dairy goods where it is a legally acceptable preservative (E234 in Europe). Nisin has the same advantages as antibiotics with the additional properties of being relatively heat stable and retaining activity at acid pH. It has the serious disadvantage, from a brewing standpoint, in that it is lethal for many Gram positive bacteria but shows no activity against most Gram negative types. This implies that it would not be suitable for controlling *O. proteus*. For this reason, as well as reluctance by brewers to add 'foreign' substances likely to persist into product, the use of nisin has not found favour.

Disinfection of pitching yeast is commonly achieved by acid washing. This process kills susceptible bacteria, but has no effect on wild yeasts. Yeasts are relatively more tolerant to acid conditions than most common bacterial contaminants. The process has a long history, Pasteur suggested that treating with tartaric acid could reduce the levels of potentially harmful bacteria in pitching yeast. In a typical modern process, yeast slurries are treated with a food grade acid such that the pH is reduced to approximately pH 2.2

(+/- 0.1) and held for 2–4 h at 3°C (+/-1°C). Several acidulants are used, the most common being phosphoric acid. Mineral acids including sulphuric, nitric and hydrochloric are also used. The efficacy of the treatment is improved by incorporating oxidizing agents such as ammonium persulphate. Thus, ammonium persulphate (0.75% w/v) plus phosphoric acid, pH 2.8, was more effective than treatment with acid alone at a pH of 2.2 (Simpson, 1987).

Whether acid washing has deleterious effects on brewing yeast is controversial. Certainly, the process must be properly controlled. Individual brewers decide on optimum conditions for their particular yeast strains. Experience suggests that the conditions described above are close to best practice. Addition of the acidulant should be done in a manner that avoids localized high acid concentration therefore the yeast slurry should be roused mechanically throughout the whole process and the acidulant dosed in gradually to ensure proper dispersion. Commonly, specific acid washing and pitching tanks are used. These have the advantages that yeast sufficient for pitching is treated with acid and there is no residue to dispose of. Acid washing tanks can be fitted with pH probes to monitor the addition of acidulant. The siting of the probe in relation to the acid dosing point should be such that there is no possibility of over-dosing. Where in-tank pH probes are not used it is preferable to remove a sample of slurry and perform a titration to determine the quantity of acidulant required to achieve the target pH. Pitching into wort terminates the acid washing via dilution with wort. If there is a process delay such that pitching is delayed it is best to avoid prolonged exposure to acid conditions by the addition of food grade sodium hydroxide solution to a pH of 4.0–4.5.

Acid washing has a dramatic effect on the appearance of many pitching yeast slurries. Commonly there is a marked reduction in viscosity. This has been attributed to deflocculation. It has been suggested that this might be implicated in a improvement in fermentation performance by acid washed yeast (Jackson, 1988). Compared with non-acid washed yeast this author reported that high-gravity worts were fermented more rapidly, the duration of the diacetyl rest was reduced and beers contained lower concentrations of acetaldehyde. More usually, deterioration of brewing yeast subject to acid washing has been observed. The effects of washing with acidified ammonium persulphate on 16 yeast strains were studied (Simpson and Hammond, 1989). Although no gross effects were observed, changes to the cell surface occurred and there was leakage of cellular contents. Using scanning electron microscopy it was demonstrated that the surface of acid washed yeast acquired characteristic 'blebs'. Prolonged treatment produced slurries that were sticky, possibly indicating some cell lysis.

It was suggested that where yeast was obviously deteriorated it should not be acid washed. This meant yeast that was heavily contaminated with bacteria, had been recovered from a previous slow fermentation or from a high-gravity fermentation where the alcohol concentration exceeded 8% v/v. The reasoning is that stressed yeast is less well able to withstand the additional stress of acid washing. Generally, yeast with a viability judged by methylene blue staining of less than 80% should not be acid washed. Where a choice exists, low viability yeast that is obviously stressed will not be chosen for repitching.

17.7 Cleaning in the brewery

The ability to keep process plant scrupulously clean is an essential prerequisite of good hygiene. This is a complex and frequently neglected part of the brewing process. Too

often when new plant and processes are installed cleaning is considered as an afterthought. Tanks and complex individual pieces of plant are usually well equipped with CIP systems. However, cleaning the pipework connecting these vessels is often not subjected to sufficient scrutiny. There is little benefit in having clean tanks if the attached pipework is a reservoir for taints or infection. Similarly, removable items such as flexible hoses and fittings of various sorts are frequently poorly cleaned and act as foci for infecting otherwise clean plant. For trouble-free operation cleaning must be treated as an integral part of the brewing process.

Cleaning is required for three reasons. Firstly, the removal of any soiling which has the potential to introduce taints into products. Secondly, the removal of soiling which has the potential to adversely affect the operation of parts of the plant, for example, building up of scale on heat exchangers. Thirdly, disinfection to eliminate any risk of microbial spoilage. This section concentrates on the latter aspect of cleaning although inevitably there is much overlap with the first two. A comprehensive review of brewery cleaning regimes and some useful definitions can be found in Singh and Fisher (1999) (Table 17.6).

The cleaning challenge changes throughout the brewing process (Fig. 17.8). At the malting stage the spoil is largely restricted to particulate materials and plant needs to be physically clean (although precautions must be taken to control mould growth). During the wort production stages the soil consists of protein, dextrans, sugars, minerals, tannins and hop materials. Heating during wort boiling can generate scale (beerstone, calcium oxalate) which becomes baked onto surfaces. There is no microbiological threat and so it is sufficient to render the plant chemically clean. From the wort cooling stage onwards the soil consists primarily of beer and yeast. Throughout all of these stages the process plant must be both chemically and microbiologically clean. This requirement extends into licensed premises where draught beers are dispensed.

Chemical cleaning relies on treatments capable of removing soils associated with wort and beer. These soils contaminate the surfaces of tanks and pipework as films that remain after product streams have drained away, so with the exception of baked-on scale, most chemical soils are loosely attached to the surfaces of brewing process plant. Microbiological soils are more complex and potentially much more tenacious. Natural mixed populations of micro-organisms are commonly found attached to surfaces as biofilms (Quain, 1999; Stickler, 1999). Indeed, this may be the preferred mode of growth. Micro-organisms in biofilms, attached by extracellular polysaccharides, are organized so as to make best use of available nutrients whilst occupying a protected location. Many surfaces, including stainless steel, are readily colonized. Many common beer spoilage bacteria are adept at forming biofilms (Czechowski and Banner (1992)). In addition to the threat posed in the brewery, biofilms are also important causes of spoilage in licensed premises. In particular, cleaning of beer dispense lines must be rigorous to ensure that biofilms are not allowed to form.

Biofilms are of significance to brewing for two reasons. Firstly, once formed they are difficult to remove, and they can act as permanent sources of contamination capable of seeding successive batches of product. Secondly, and perhaps more importantly, analysis of suspended microbial counts may dramatically underestimate the true magnitude of contamination. Usually assessment of contamination is based on measurement of the free-living population. Hygiene tests should be based on the swabbing of surfaces rather than analysis of rinse water. Cleaning regimes must be sufficiently vigorous to prevent biofilms forming.

Table 17.6 Cleaning regimes – definitions (adapted from Singh and Fisher, 1999)

Term	Definition
Physical cleanliness	Visually clean.
Chemically clean	Cleaned surface imparts no contamination to product. Cleaned surface wets completely with clean water and forms a continuous film.
Microbiologically clean	Absence of microbiological contamination.
Cleaning-in-place (CIP)	Automatic cleaning of plant without the need to dismantle.
Soil	Any substance in the wrong place but typically residues from process liquids and solids.
Detergent	A chemical cleaning agent, often with surfactant properties for removing soil from surfaces.
Disinfection	Treatments that kill micro-organisms and reduce loadings to a desired concentration. It does not imply total killing (sterilization).
Production sterility	Term used in industrial microbiology to describe a state in which plant or processes are disinfected to produce conditions which do not result in spoilage.
Chemical sterilant	A chemical disinfectant.
Sanitization	Process which is a combination of cleaning and disinfection.

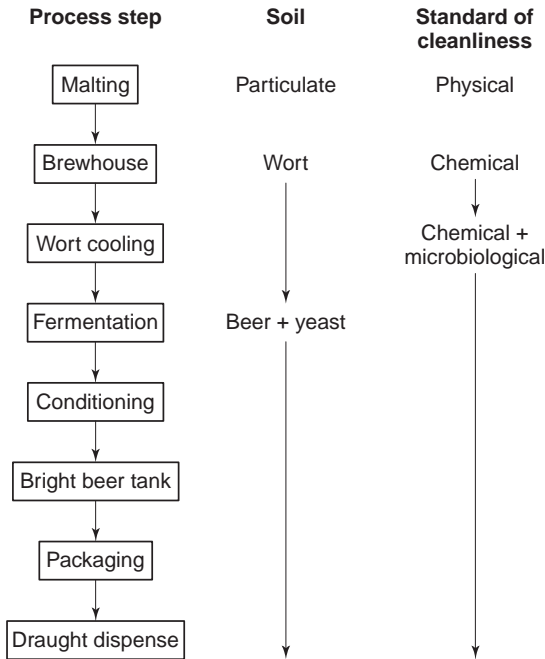

Fig. 17.8 Nature of the soil and the standard of cleanliness required at various stages in the brewing process.

17.7.1 Range of cleaning operations

Many traditional breweries use open vessels and these may still be cleaned manually using buckets and brushes. However, attempts have been made to improve the efficiency of cleaning, using less manpower. Undoubtedly, this has encouraged the adoption of automatic cleaning regimes. Thus, traditional open vessels, such as fermenters, are commonly fitted with detachable hoods that are fitted to enclose the vessel during automatic cleaning. Detachable fittings such as hose adapters, valves, swing bends, components of fillers, flexible hoses, etc., may be cleaned manually followed by immersion in soak baths filled with a suitable disinfectant. Surfaces of complex equipment such as fillers and crowners are commonly cleaned with foams or gels which have excellent wetting properties and an ability to penetrate into hard-to-reach areas. With bottle and can filling machines foaming sprays are often part of an automatic cleaning system of external surfaces. Environmental cleaning can be a neglected area, particularly with the increased enclosure of the brewing process. Nevertheless in sensitive areas, such as filling halls and yeast rooms, walls, floors and ceilings should be cleaned with high-pressure sprayers.

Individual pieces of plant tend to be fitted with dedicated automatic cleaning-in-place (CIP) systems such as various types of vessel and associated equipment such as heat exchangers, centrifuges and filters. Intervening pipework may be cleaned as part of CIP circuits with vessels or other pieces of plant. Some pipe runs may need to be cleaned independently. The proximity of cleaning fluids and beer streams requires a high standard of engineering to ensure that no cross-contamination can occur. In sophisticated and complex brewery processes, cleaning and other operations are usually fully automatic and computer controlled. These systems include fail-safe arrangements to ensure that possible conflicts are eliminated. On the other hand fully automatic systems are often inflexible.

The use of enclosed equipment introduces a barrier between the process and the external environment. Together with improved cleaning this has improved microbiological standards. However, these improvements have been costly. CIP systems are expensive in both capital and revenue, therefore it is essential that each system is appropriate for its job. Once a system has been chosen, its operation must be optimized to maintain a balance between efficiency of cleaning and cost of the operation. Several factors impact on the efficiency of cleaning including the vigour of the delivery of the cleansing agents to the plant being cleaned. The duration of the treatment, the temperature and nature of the chemical agents used are all influential.

Proper design of brewery plant is an essential prerequisite of good cleaning. Items such as tanks are fitted with spray-balls, which are designed to distribute jets of cleaning fluids such that all internal surfaces are cleaned. The jets emanating from spray-balls must be able to reach all parts of the vessel. Two types of spray-ball are used. Low-pressure types rely on being placed in an appropriate location to ensure adequate coverage of surfaces. High-pressure spray-balls are caused to rotate by the incoming fluid and thereby ensure that all surfaces are covered. Cleaning fluid is collected via the pipework of the piece of equipment being cleaned and re-circulated back through the spray-balls. Internal metal surfaces must be polished to a suitable standard to ensure that there are no crevices to harbour microbial cells. Similarly, internal welds and fittings such as sample cocks must not provide shadow areas where soil cannot be removed. The rate of delivery of cleaning fluids must be balanced with rates of draining so that flooding does not occur and thereby negate the scouring action of the spray-balls. Often this is accomplished by delivering the cleaning agent in a series of bursts. The duration of successive cleaning treatments must allow for proper draining to avoid intermixing.

Design and the velocity and turbulence of cleaning fluids influence cleaning of pipework. Proper cleaning of pipes requires complete filling with fluid to ensure wetting of all surfaces. The diameter of the pipe, the velocity of the fluid flow and the aspect of the pipe relative to the fluid flow influence filling. The larger the diameter of the pipe the higher the flow rate must be to ensure complete filling. As a rule of thumb, a pipe with a diameter of 3 in. (7.62 cm) requires a flow rate of at least $2.2 \text{ m}\cdot\text{sec}^{-1}$ to ensure complete filling (Fig. 17.9). Vertical runs of pipe work are adequately filled providing the liquid flow is upwards. Where the fluid flow is vertically downwards even greater velocities are needed to ensure complete flooding. In the case of a three-inch pipe the vertical down-flow rate must be increased to at least $8.5 \text{ m}\cdot\text{sec}^{-1}$ to ensure complete wetting. This problem can be ameliorated by slightly reducing the diameter of vertical pipe runs. Alternatively, non-return valves may be used. Some common problems associated with pipe runs and remedies are shown in Fig. 17.10.

The duration of cleans and the temperature at which cleaning agents are delivered is a balance between efficiency and cost. An increase in both parameters is associated with an increase in cost. The efficacy of alkaline detergents both for removing soil and for killing micro-organisms is increased by elevated temperatures. In order to achieve a given level of cleanliness and microbial kill, there is a rough negative correlation between detergent strength and temperature. Similar relationships exist between both of these parameters and the duration of the clean. Several authors maintain that soil that is formed hot should be removed hot (Platt, 1986, Singh and Fisher, 1999;). On this basis, most of the brewhouse, wort paraflows and pasteurizers should be cleaned hot. However, most areas which receive heavy yeast soils, such as yeast storage tanks and propagation plants, tend to be cleaned hot. Preliminary rinses and acid detergents are usually applied cold, whereas alkaline detergents are used hot. Irrespective of the operation, the guiding

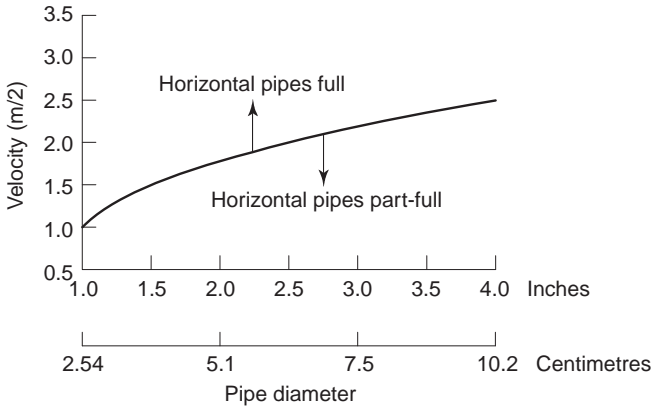

Fig. 17.9 Relationship between pipe diameter and velocity of fluid flow required to ensure that horizontal pipe runs remain full of liquid.

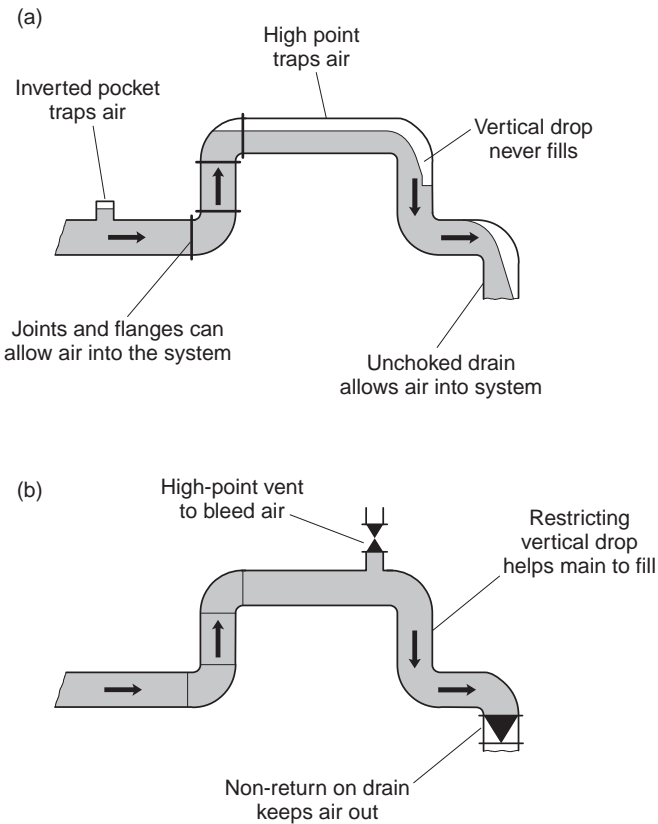

Fig. 17.10 Poorly designed pipework (a) and some possible improvements (b) (Diagram courtesy of A. Mielenewski).

principle must always be achievement of a desired clean within an acceptable time and at an acceptable cost. Singh and Fisher (1999) conveniently quantified the total cleaning energy required as the sum of chemical energy (strength of cleaning agent), mechanical energy and thermal energy.

17.7.2 CIP systems

Several variations are used, all sharing some common features. Cleaning agents are stored in tanks, which are attached to the pieces of equipment and pipework that need to be cleaned. Cleaning agents are delivered from storage tanks to the plant by dedicated pumps. Usually a smaller scavenging pump returns fluids to the cleaning tanks to form a CIP circuit. Additional pipework allows the liquid flow to be directed to drain, as appropriate. The whole arrangement is termed a CIP set. Very sensitive pieces of equipment may have their own dedicated CIP sets. More usually, one or a small number of CIP sets serve particular parts of the brewery process. The total number of CIP sets available influences the capacity and flexibility of the cleaning operation. Large numbers of CIP sets increases the cost of the operation. CIP may be manual or automatic. Manual systems are flexible and allow one or a small number of CIP sets to service many different parts of the brewery. The nature of the cleaning regime can be varied to suit the type of soil that needs to be removed. Automatic regimes are inflexible and more expensive than manual types, however they tend to give a more uniform cleaning process.

Total dump (total loss or single use) systems do not recover any of the cleaning fluids or rinses. They are profligate in terms of chemical and water usage and produce the most effluent, so they are used only in areas of heavy soil where cleanliness and microbiological hygiene are of paramount importance, e.g., in yeast propagation plant. They may also be used in conjunction with caustic-based detergents where there is a high concentration of CO₂. Typically, single use CIP sets are dedicated to single pieces of plant. They are located in close proximity to the piece of equipment they are required to clean.

Partial and total recovery systems save some costs by recovering a proportion of the cleaning fluids. In these systems some or all of the dilute detergent is retained, after topping up with fresh detergent to ensure that it is of the correct strength it is re-used. Similarly, a proportion of rinse waters may be returned to the CIP set and re-used. These systems are used where the cleaning task is less onerous, for example, bright beer tanks. CIP sets have a manual or automatic means of setting the cycle times for individual steps in the cleaning process. A thermometer and thermostat is needed to set the temperature for hot treatments. Where caustic-based detergents are used it is usual to monitor the strength by means of a conductivity probe. This may be used as part of an automatic loop system for dosing concentrated detergent into feed tanks. Care must be taken when assessing caustic concentration based on conductivity measurements (Section 17.7.5).

CIP treatments consist of a number of individual steps. At the start the plant being cleaned must be empty so that there is no dilution of cleaning agents. Similarly, the plant must be fully drained between individual treatments to ensure that there is no intermixing and consequent reduction in the effectiveness of liquids. The process starts with a pre-rinse to remove heavy soil. Often pulsed rinsing is used to improve the efficiency of soil removal. The pre-rinse is sent to drain and in recovery systems, the liquid used is often derived from a recovered final rinse from a previous CIP. The main detergent clean follows the pre-rinse. This is the longest part of the process in which the liquid is circulated through the CIP circuit, typically 30–60 minutes. In total dump systems the detergent is sent to drain. In recovery systems it is retained and used in subsequent cleans. Where alkaline detergents are used an acid rinse may follow to neutralize residual alkali. The process is completed by a terminal rinse, which typically includes a sterilant. Terminal sterilants include peracetic acid, chlorine dioxide and, now more rarely, sodium hypochlorite. In some cases it is not appropriate to use a sterilant since it may affect the process or the beer, for example, propagation plant and packaging lines. In these cases sterility can be assured by a final treatment with wet anaerobic steam.

17.7.3 Cleaning agents

Soil removal is much improved by the use of detergents. These act synergistically with physical cleaning processes by loosening soils from surfaces. Several roles performed by detergents are recognized (Singh and Fisher, 1999). Physical effects include wetting of surfaces, dispersion of large agglomerates of soil to form finely divided particulate matter and suspension of soil in solution. Chemical effects include dissolution of inorganic mineral scale by acid detergents, saponification of lipophilic components by alkaline detergents and hydrolysis of proteins.

For the removal of heavy soils the most commonly used detergents are those based on sodium hydroxide. Typically caustic soda is used at a concentration of 2–5% w/v at a temperature of 70–90 °C. It is a very good cleaning agent and, when hot, is an effective biocide and efficient at removing biofilms (Czechowski and Banner, 1992). It has two major disadvantages. Caustic soda reacts with CO₂ to produce sodium bicarbonate. In parts of the brewery, such as fermenters where there are high concentrations of CO₂, this can dramatically reduce the effectiveness of caustic detergents. Thus, 1 m³ of CO₂ at 1 bar and 20 °C will neutralize 2 kg of NaOH (Gingell and Bruce, 1998). To avoid this problem it is necessary either to ensure that vessels and pipework are vented to remove CO₂ or to appreciate that losses will occur and increase the dosage of caustic detergent accordingly. Alternatively, acid-based detergents can be used in areas where CO₂ will be a problem.

Caustic soda reacts with the salts that cause hardness in water to form insoluble precipitates in the form of calcium carbonate and magnesium hydroxide. The precipitates can accumulate on the surfaces in the form of scale. The problem is exacerbated in areas subjected to hot cleaning such as parts of the brewhouse. To counter this detergents are routinely supplemented with chemical additives termed sequestrants. These are of two types (Table 17.7). Stoichiometric sequestrants form soluble chelates with metal ions. They break down mineral precipitates in soils or prevent their formation such that scale formation is minimized. Threshold sequestrants do not prevent the formation of water hardness precipitates, rather they modify their crystal structure such that they do not adhere to surfaces and form scale.

Acidic detergents have no reaction with CO₂ and, therefore, are suitable for use with fermenters and associated plant. Commonly they are used cold. Their use for cleaning of fermenters is not popular since, compared to hot caustic detergents, they are less efficient at removing heavy soils. However, they do remove scale and, where this becomes a problem, they may be chosen for occasional use. Acid and caustic detergents can be used sequentially in heavily soiled locations such as fermenters. In this case, a caustic pre-rinse is used to remove the worst of the soil followed by an acid-based clean. Acidic detergents are often used for keg washing. The most commonly used acid is phosphoric acid. This is sometimes supplemented with nitric acid. When used caution must be exercised since acidic detergents are corrosive.

The efficacy of both acid and alkaline detergents can be enhanced by the incorporation of surfactants. These are molecules that have both hydrophobic (non-polar) and hydrophilic (polar) groups. They improve wetting by reducing the surface tension of liquids. This is achieved by their tendency to adopt a configuration in which the non-polar groups become aligned towards the surface of liquids and the polar groups lie in an inward-facing orientation. Above certain concentrations (the critical micellar concentration) the non-polar groups form aggregates termed micelles. These trap lipophilic soil particles and prevent them from re-adhering to surfaces. Water-insoluble surfactants are defoaming and are used where the formation of foam is undesirable, such as bottle

Table 17.7 Sequestrants used in CIP cleaning agents (after Singh and Fisher, 1999)

Generic sequestrant	Examples	Action
1. Stoichiometric sequestrants		
Amino carboxylic acids	Ethylenediaminetetraacetic acid (EDTA) Nitrilotriacetic acid (NTA)	Chelator of metal ions forming stable complexes and helping to remove scale or prevent its formation.
Hydroxycarboxylic acids	Derivatives of gluconic acid	Chelator of Ca^{2+} , Fe^{3+} , Al^{3+} . Effectiveness is increased in the presence of free NaOH and activity is maintained at high temperature. They are used in the brewhouse and for bottle washing.
Polyphosphates	Sodium tripolyphosphate Sodium hexametaphosphate	Relatively insoluble chelators often used as constituents of powdered detergents.
2. Threshold sequestrants		
Phosphonic acid derivatives	Amino, tris-(methylenephosphonic acid) (ATMP) 1-Hydroxyethane diphosphonic acid (HEDP)	Modifiers of the crystal structure of precipitates so that they do not adhere to surfaces and form scale. Used in conjunction with caustic soda.

washers. Conversely, water-soluble surfactants produce stable foams and are used in foam cleaners. Surfactants are able to disrupt biological membranes and consequently many are powerful biocides.

Anionic surfactants have negatively charged dissociated groups. They have the properties of soaps and are used as conveyor belt lubricants. Conversely, cationic surfactants have positively charged dissociated groups. Some are used as corrosion inhibitors in water treatment systems, for example in pasteurizer sprays. The most common cationic surfactants are quaternary ammonium compounds. They have disinfectant activity. Amphoteric surfactants have a charge that is dependent on the pH of the medium they are added to. They have good biocide activity and are used in soak baths or as foam sprays. Non-ionic surfactants are electrically neutral and are used as CIP additives.

Disinfectants (often called sanitizers) have several applications in ensuring microbiological cleanliness in brewing. Where process sterility is important, roughly from wort cooling onwards, disinfectants are incorporated into terminal rinses at the end of CIP to ensure that microbiological loadings remain at low levels. They are used in soak baths for the same reason. Disinfectants are used in foam spray cleaners and are used as additives to cleaning agents for some manual operations. They are incorporated into non-process water to prevent microbial growth. Several types are available depending on the application. Disinfectants should have a number of attributes (Singh and Fisher, 1999). They should exhibit biocide activity towards a broad spectrum of micro-organisms at low concentration, be inexpensive and have no effect on plant, product or other chemical agents that they may come into contact with. None meet all of these needs and some compromises must be made.

Several halogen-containing compounds exhibit disinfectant properties due to their oxidizing properties (see Chapter 3). Those containing chlorine are most commonly used in brewing. Two forms are used, sodium hypochlorite and chlorine dioxide. In alkaline solutions, sodium hypochlorite is relatively stable and it is supplied in this form. At acid pH (< 5.0) it forms hypochlorous ions, the active form of chlorine which is a powerful biocide. It is used at a concentration of 50–300 mg.l⁻¹ as a terminal sterilant in rinse liquors. Hypochlorite has several disadvantages the most serious of which is its ability to cause corrosion. It is quite unstable especially at low pH (< 5.0) where free chlorine is generated. Sodium hypochlorite reacts with some organic compounds to form chlorophenols and chloramines. These can produce taints. In addition, trihalomethanes are potential carcinogens.

Some of the disadvantages of hypochlorite are avoided by chlorine dioxide (Cadwallader, 1992). This is becoming increasingly popular and is tending to replace hypochlorite as the disinfectant of choice for use in terminal rinses. In fact, it is often used to treat all water used throughout the brewing process (Chapter 3). Usually it is synthesized in special generating equipment in which HCl is mixed with a solution of sodium chlorite. The reaction between these two chemicals forms chlorine dioxide, which is dosed into water at a concentration of 0.1–0.5 mg.l⁻¹. At this concentration it is nearly three times more effective as a biocide than hypochlorite. It is non-toxic, does not produce taints and does not cause corrosion.

Iodine is complexed with surfactants to form preparations termed iodophores. These are powerful disinfectants and are used at concentrations of 10 mg.l⁻¹ available iodine in soak baths and in spray cleaners. At high concentrations they can be corrosive and impart taints and so care must be taken to ensure that they are diluted according to the supplied instructions. Preparations containing bromine (0.5 mg.l⁻¹ available bromine) are used in the treatment of re-circulating water.

Peracetic acid (CH₃-CO-OOH) is often incorporated into final rinses as a terminal sterilant. It is a powerful disinfectant owing to the fact that it decomposes to form acetic

acid and hydrogen peroxide. It is used cold at a concentration of 75–300 mg.l⁻¹. It is difficult to handle in concentrated form, it has an unpleasant odour and it is corrosive. For these reasons the bulk supply must be stored in portable tanks in a bunded area. The storage area should be vented since over time peracetic acid decomposes and generates gaseous oxygen. The difficulties with handling mitigate against its use and increasingly it is being replaced with chlorine dioxide.

Non-oxidizing disinfectants used in brewing include quaternary ammonium cationic surfactants, amphoteric surfactants and biguanides. All are used as components of soak baths. Each has strengths and weaknesses. They are too foam active to be used in CIP. Quaternary ammonium compounds, used at a concentration of around 200 mg.l⁻¹, show little activity against Gram negative bacteria and they can impart unpleasant fishy taints. Amphoteric types are equally effective against Gram negative and Gram positive bacteria at concentrations around 1,000 mg.l⁻¹. They are ineffective against moulds and yeast. Biguanides are derived from guanidine. They are active disinfectants towards a similar spectrum of micro-organisms as amphoteric surfactants but only within the range of pH 3.0–9.0. Biguanides are also used to disinfect recirculating water supplies.

17.7.4 Cleaning beer dispense lines

The microbiological integrity of small pack beers must be guaranteed throughout their shelf-lives. For draught products microbiological quality assurance must extend beyond the brewery to the premises where they are dispensed. There is no benefit to be gained in ensuring the highest standards of quality up to the point at which beer leaves the brewery without extending this to the management of hygiene within licensed premises. Central to this is the proper cleaning of dispense lines and associated equipment.

Adequate cleaning of beer lines prevents the formation of biofilms. Materials best suited for use in beer lines have been investigated (Thomas and Whitham, 1996). A variety of materials were investigated for their ability to support biofilms. Nylon and medium-density polythene were the least favourable supports and these are recommended for use in beer lines. PVC was the least suitable material. Best practice for line cleaning has been reviewed (Treacher, 1995). Several proprietary line cleaning agents are available and all share common features. They are supplied as concentrates and require dilution with water to a concentration of 1% v/v. They contain sodium hydroxide as the primary detergent together with sodium hypochlorite (250 mg.l⁻¹ chlorine) for disinfection purposes and a sequestrant for water softening. Several contain indicator dyes to provide a visual indication that cleaner is present in beer lines.

Beer lines should be cleaned at least every seven days. First the line is flushed with clean water to eliminate any beer. It is then filled with detergent and left to soak for at least 20 minutes and no more than 30 minutes. During this time beer coolers should be switched off to prevent freezing. During the soak period the detergent action can be improved by agitation and half way through the soak the detergent should be replaced with a fresh supply. Finally, the lines should be flushed with clean water until no more cleaner can be detected, e.g., with indicator papers. The water should then be chased through with beer at which point the line is ready for re-use. During the soaking period it is essential that the lines and dispense equipment are completely filled with cleaning fluid. Any venting apparatus, etc., should be fully open during the initial filling procedure. Coupling devices, etc., must be removed and cleaned separately before the lines are soaked. Extending the soak time beyond the recommended period can damage dispense equipment and lead to taints being imparted to beers.

17.7.5 Validation of CIP

It is essential that procedures are followed to ensure that CIP processes are carried out correctly. Two types of validation procedure are used. Firstly, checks must be made to confirm that the conditions employed during the cleaning process were within the predetermined specification. Secondly, the cleanliness of the plant must be assessed against predetermined standards.

CIP checks include cycle times, temperatures and the strengths of cleaning chemicals. Assuring that the correct concentration of caustic soda-based detergent is used is worthy of special comment. Commonly, the strengths of solutions of caustic soda are assessed by measurement of conductivity. Such readings can be misleading since conversion of sodium hydroxide to sodium bicarbonate following exposure to carbon dioxide does not produce a change in this parameter. Preferably, the concentration of caustic soda solutions should be checked by off-line titration.

The cleanliness of plant after CIP can be checked using ATP bioluminescence (Section 17.3.1). Where possible this should be supplemented with visual checks to ensure that spray-balls are functioning correctly and no shadow areas exist. Recently the use of a video camera, termed the 'Topsan', mounted in the top of cylindroconical fermenters has been recommended for examining vessel cleanliness (Wasmuht and Weinzart, 1999). Validation of CIP is essential when new plant is commissioned. Since CIP is a costly and time-consuming process it is necessary to employ conditions that provide the desired level of cleaning at the lowest cost.

17.8 References

- AMAHA, M., KITABATAKE, K., NAKAGAWA, A., YOSHIDO, J. and HARADA, T. (1974) *Bull., Brew. Sci.*, **20**, 35.
- AMERICAN SOCIETY OF BREWING CHEMISTS (1992) *Methods of Analysis*, 8th edn, American Soc. Brew. Chem., St. Paul, Minnesota.
- ARCHIBALD, F. S. and FRIDOVICH, L. (1981) *J. Bacteriol.*, **146**, 928.
- BOEIRA, L. S., BRYCE, J. H., STEWART, G. G. and FLANNIGAN, B. (1999a) *J. Inst. Brew.*, **105**, 366.
- BOEIRA, L. S., BRYCE, J. H., STEWART, G. G. and FLANNIGAN, B. (1999b) *J. Inst. Brew.*, **105**, 376.
- BOULTON, C. A. and QUAIN, D. E. (2001) *Brewing Yeast and Fermentation*, Blackwell Science Ltd., Oxford.
- BRIDSON, E. Y. (1998) *Oxoid Manual*, 8th edn, Oxoid Ltd., Hampshire, UK.
- CADWALLADER, S. D. (1992) *Ferment*, **4**, 380.
- CASE, A. A. and LYON, A. I. L. (1956) *J. Inst. Brew.*, **62**, 477.
- CZECHOWSKI, M. H. and BANNER, M. J. (1992) *MBAA Tech. Quart.*, **29**, 86.
- DE LEY, J., SWINGS, J. and GOSSELE, F. (1984) 'Key to the genera of the family *Acetobacteraceae*'. In *Bergey's Manual of Systematic Bacteriology*, 9th edn, Vol. 1., N. R. Krieg and J. G. Holt, eds, Williams and Wilkins, Baltimore, p. 268.
- DIMICHELE, L. J. and LLEWIS, M. J. (1993). *J. Amer. Soc. Brew. Soc.*, **51**, 63.
- ENGELMANN, U. and WEISS, N. (1985) *Systematics and Appl., Microbiol.*, **6**, 287.
- EUROPEAN BREWERY CONVENTION (1998), *Analytica Microbiologica* Vol. II 5th edn, H. C. Verlag, Germany.
- FLANNIGAN, B. (1999). 'The microflora of barley and malt'. In *Brewing Microbiology*, F. G. Priest and I. Campbell, eds, Aspen Publishers, Inc., Gaithersburg, Maryland, pp. 83–126.
- FLEET, G. (1992) *Crit. Rev. Biotechnol.*, **12**, 1.
- GILLILAND, R. B. (1971) *J. Inst. Brew.*, **77**, 276.
- GINGELL, K. and BRUCE, P. (1998) *Proc. 23rd IOB Conv., Asia Pacific Sect., Perth*, 134.
- GRAY, P. P. and KAZIN, A. D. (1946) *Wallerstein Lab. Commun.*, **9**, 115.
- GUTTERIDGE, C. S. and PRIEST, F. G. (1999) 'Methods for the rapid identification of microorganisms'. In *Brewing Microbiology*, F. G. Priest and I. Campbell, eds., Aspen Publishers, Inc., Gaithersburg, Maryland, pp. 239–270.
- HAIKARA, A. (1989) *Proc. 22nd Cong. Eur. Brew. Conv., Zurich*, 537.
- HAIKARA, A. and LOUNATMAA, K. (1987). *Proc. 21st EBC Cong., Madrid*, 473.
- HAMMOND, J. R. M. and ECKERSLEY, B. W. (1984) *J. Inst. Brew.*, **90**, 167.
- HYSERT, D. W., KOVACS, F. and MORRISON, N. M. (1976) *J. Am. Soc. Brew. Chem.*, **34**, 145.

- INSTITUTE OF BREWING (1997) *Methods of Analysis, Vol. 2, Microbiological*, I. O. B., Clarges St., London.
- JACKSON, A. P. (1988) *Tech. Quart. Master Brewers Assoc. Americas*, **25**, 104.
- JOHNSTON, M. A. and DELWICHE, E. A. (1965) *J. Bacteriol.*, **90**, 347.
- KENNEDY, A. L. and HARGREAVE, L. (1997) *Proc. EBC Symp. Monograph XXVI, Stockholm*, 58.
- KITABATAKE, K. and AMAHA, M. (1974) *Bull. Brew. Sci.*, **20**, 1.
- MAGLIANI, W., CONTI, S., GERLONI, M., BERTOLOTTI, D. and POLONELLI, L. (1997) *Clin. Microbiol. Rev.*, **10**, 369.
- MAGNUS, C. A., INGLEDEW, W. M. and CASEY, G. P. (1986) *J. Am. Soc. Brew. Chem.*, **44**, 158.
- MAULE, A. P. and THOMAS, P. D. (1973) *J. Inst. Brew.*, **79**, 137.
- MCCAIG, R. and MORRISON, M. (1984) *J. Am. Soc. Brew. Soc.*, **42**, 23.
- MUNDY, A. P. (1997) *Proc. EBC Symp. Monograph XXVI, Stockholm*, 141.
- OGDEN, K. (1987) *J. Inst. Brew.*, **93**, 302.
- OGDEN, K. (1993) *J. Inst. Brew.*, **99**, 389.
- PHILLISKIRK, G. and YOUNG, T. W. (1975) *Antonie Van Leeuwenhoek*, **41**, 147.
- PLATT, D. (1986) *Brew. Dist. Internat.*, **16**, 20.
- PRIEST, L. M., HARLEY, J. P. and KLEIN, D. A. (1996) *Microbiology*, McGraw-Hill, USA.
- PRIEST, F. G. (1999) 'Gram positive brewery bacteria'. In *Brewing Microbiology*, F. G. Priest and I. Campbell, eds., Aspen Publishers, Inc., Gaithersburg, Maryland, pp. 127–161.
- QUAIN, D. E. (1999) *Proc. 27th EBC Cong., Cannes*, 239.
- RUSSELL, I. and DOWHANICK, T. M. (1999). 'Rapid detection of microbial spoilage'. In *Brewing Microbiology*, F. G. Priest and I. Campbell, eds., Aspen Publishers, Inc., Gaithersburg, Maryland, pp. 209–235.
- RYDER, D. S., MURRAY, J. P. and STEWART, M. (1978) *MBAA Tech. Quart.*, **15**, 79.
- SAMI, M., YAMASHITA, H. and HORONO T. (1997a) *J. Ferment. Bioengin.*, **84**, 1.
- SAMI, M., YAMASHITA, H., KADOKURA, H., KITAMOTO, K., YODA, K. and YAMASAKI, M. (1997b) *J. Am. Soc. Brew. Chem.*, **55**, 137.
- SHIMWELL, J. L. (1936) *J. Inst. Brew.* **42**, 585.
- SIMPSON, W. J. (1987) *J. Inst. Brew.*, **93**, 313.
- SIMPSON, W. J. (1993) *J. Inst. Brew.*, **99**, 405.
- SIMPSON, W. J. (1999) *Brewers' Guardian*, **May**, 24.
- SIMPSON, W. J. and FERNANDEZ, J. L. (1992) *Lett. Appl. Microbiol.*, **14**, 13.
- SIMPSON W. J. and FERNANDEZ, J. L. (1994) *J. Am. Soc. Brew. Chem.*, **52**, 9.
- SIMPSON, W. J. and HAMMOND, J. R. M. (1989) *J. Inst. Brew.*, **95**, 347.
- SIMPSON, W. J. and HAMMOND, J. R. M. (1991) *Proc. 23rd EBC Cong., Lisbon*, 185.
- SIMPSON, W. J., HAMMOND, J. R. M., THURSTON, P. A. and KYRIAKIDES, A. L. (1989) *Proc. 23rd EBC Cong., Lisbon*, 185.
- SINGH, M. and FISHER, J. (1999). 'Cleaning and disinfection in the brewing industry'. In *Brewing Microbiology*, F. G. Priest and I. Campbell, ed., Aspen Publishers, Inc., Gaithersburg, Maryland, pp. 271–300.
- SMITH, N. A. (1994) *J. Inst. Brew.*, **100**, 347.
- SPECKMAN, R. A. and COLLINS, E. B. (1973) *Appl. Microbiol.*, **26**, 744.
- STICKLER, D. (1999) *Curr. Opinion in Microbiol.*, **2**, 270.
- TAKAHASHI, T., NAKAKITA, Y., MONJI, Y., WATARI, J. and SHINOSTUKA, K. (1999a) *Proc. 27th Cong. EBC, Cannes*, 259.
- TAKAHASHI, T., NAKAKITA, Y., SUGIYAMA, H., SHIGYO, T. and SHINOTSUKA, K. (1999b) *J. Biosci., Bioeng.*, **88**, 500.
- THOMAS, K. and WHITHAM, H. (1996) *Proc. EBC Symposium, Edinburgh, Monograph XXV*, 124.
- TREACHER, K. (1995) *Brew. Guard.*, **Aug.**, 19.
- TSUCHIYA, Y., KANO, Y. and KOSHINO, S. (1992a) *J. Am. Soc. Brew. Chem.*, **51**, 40.
- TSUCHIYA, Y., KANEDA, H., KANO, Y. and KOSHINO, S. (1992b) *J. Am. Soc. Brew. Chem.*, **51**, 64.
- VAN VUUREN, H. J. J. (1999) 'Gram negative spoilage bacteria'. In *Brewing Microbiology*, F. G. Priest and I. Campbell, eds., Aspen Publishers, Inc., Gaithersburg, Maryland, pp. 163–191.
- VERZELE, M. (1986) *J. Inst. Brew.*, **92**, 32.
- WAINWRIGHT, T. (1972) *Brewers' Digest*, **47**, 78.
- WASMUHT, K. and WEINZART, M. (1999) *Brauwelt Internat.*, **17**, 512.
- WHITE, F. H. (1994) *Proc. EBC Symp., Monograph XXI, Nutfield*, 2.
- YASUI, T. and YODA, K. (1997) *Appl. Environ. Microbiol.*, **63**, 4528.
- YOUNG, T. W. (1987) 'Killer yeasts'. In *The Yeasts*, 2nd edn, Vol. 2. A. H. Rose and J. S. Harrison, eds, Academic Press, London, pp. 131–164.

Brewhouses: types, control and economy

18.1 Introduction

The objective of this chapter is to consider the evolution of brewhouses and to consider briefly the diversity of design of breweries that are operated today. Control systems and economic aspects of operation will be considered.

Brewhouse equipment must operate in a reproducible way to yield wort with a composition that is expected from an understanding of the biochemistry of the process (Chapter 4). In large breweries (say, greater than 500,000 hl, or 300,000 imp. bbl annual volume) of great importance is the ease with which brewhouse equipment can be automated, however, there is a warning here. Biochemists study enzymes in model systems at controlled pH value and temperature often approaching ideal conditions. The environment in a brewery mash is not ideal and sometimes unpredictable results will occur. The level of automation should, therefore, be such that manual intervention can easily take place when things go wrong. This will avoid the production of a series of worts of poor quality with consequent adverse quality and economic effects.

A good brewhouse, then, is a set of vessels which will allow the biochemical reactions of brewing to take place in a controlled way as close as possible to the ideal environment in which the enzymes have been mostly studied. Engineers, therefore, should utilize the experience of brewers and scientists so that the equipment they design and sell will effectively support the critical enzyme activities needed for wort production.

18.2 History of brewhouse development

Visiting different breweries reveals considerable variation in the methods of construction and the layout of the plant. Pioneering work in the late 19th century by Horace Brown and others (Anderson, 1993) stimulated brewers to think even more carefully about brewhouse design. Economic pressures also became more acute at this time and competition in the brewing industry became a reality. Directors of Companies demanded adequate financial returns on the capital employed in the brewery and looked to make

profit from the brewing of beer. In the late 19th century most brewers were brewers for sale and did not own the premises in which beer was sold. The cost of beer production, therefore, now came to be understood and its control was vital to Company success. This happened in Europe, particularly in the UK and in North America (Anderson, 1993). Brewers were thus forced to look critically at the design of the plant they were using to produce their beer.

To lower costs it was appreciated that economies of scale were important and larger breweries (> 300,000 hl pa) were built, mainly in the UK. In the middle of the 19th century in Germany, however, there were around 15,000 breweries and many of these were extremely small, concentrating on brewing for one retail outlet. Some of these breweries, only partially modernized, exist today. However, it has been much easier to introduce new technology and lower costs in larger breweries and this has been the fashion in the UK, North America, Scandinavia and Japan throughout the 20th century. Developments in the USA were, of course, severely restricted by the introduction of the prohibition of alcohol that lasted from 1919 to 1933.

The choice of raw materials for brewing has also influenced developments. Brewers established themselves commercially in the German States in the 15th century and municipal laws closely controlled their activities. To avoid the use of substitute materials, some of which had been injurious to health (some flavourings replacing hops), the purity law, the *Reinheitsgebot*, was introduced in 1516 and has applied throughout Germany since 1906. The law declares that beer can be made only from barley, water and hops. This has strongly influenced the development of brewing technology in Germany in the last 100 years. The *Reinheitsgebot* applied in many countries in the early stages of brewing development, particularly as so many German brewers emigrated. But by 1870 American brewers had experimented with maize and rice mash tun adjuncts to economic advantage and did not go back to barley malt alone. In the UK there was a plentiful supply of sugar from the West Indies and again this was used to advantage to lower costs. Against this background the different trends in brewhouse improvement must be set.

18.2.1 The tower brewery lay-out

The development of the steam engine by James Watt in 1765 provided the basis for the industrial revolution in Victorian Britain. Brewers were quick to relate the scientific work of Horace Brown to Watt's great invention and also to the pioneering work of Joule in the early 1840s (working in the laboratory of the family brewery in Salford) leading to the First Law of Thermodynamics, and hence the concept of the mechanical equivalence of heat.

Brewers in the 19th century quickly realized that making more use of gravity could lower costs in the brewhouse. The concept of the 'Tower' brewery was born with consequent savings in energy and manual labour. The need for excessive pumping of worts was eliminated, resulting in quality improvements as potential sources of infection and oxidation were lessened.

Tower breweries had a flat roof supporting water cisterns and tanks (Fig. 18.1). A considerable weight had to be supported on a small area. The buildings, therefore, had to be very substantially constructed with solid foundations and thick walls. These methods of construction were immediately available in the mid to late 19th century through to the 1950s (Jeffery, 1956), when cheaper building materials were developed. This meant that the excessive demands of the civil construction of the Tower brewery became very

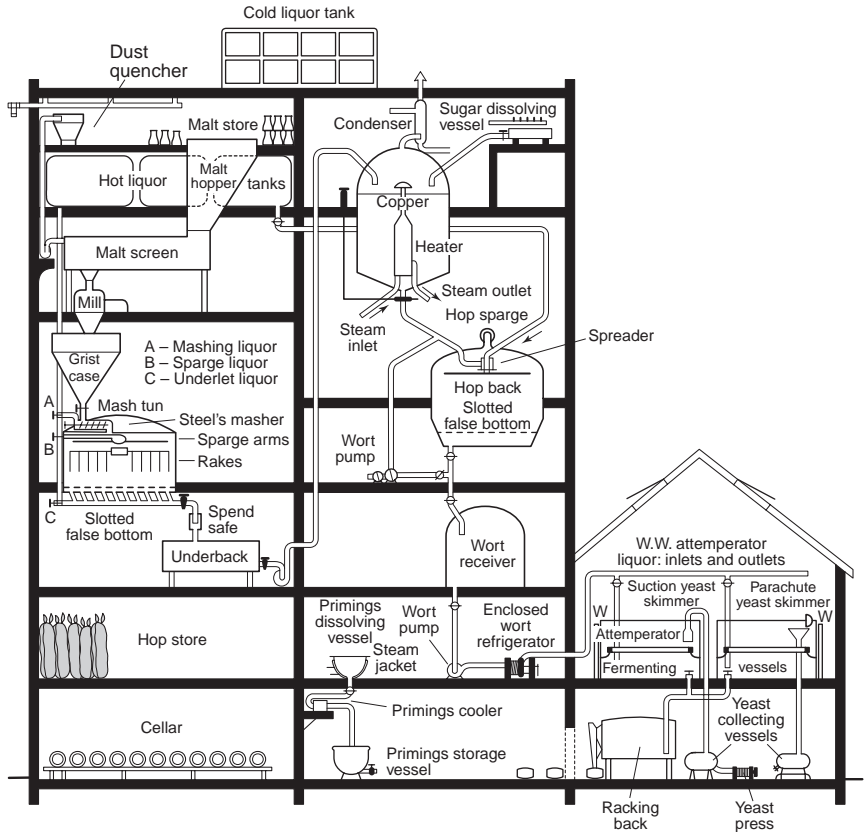

Fig. 18.1 Sectional representation of a traditional small ale 'Tower' brewery, operating with one elevation of the wort to the Wort Boiler (Jeffrey, 1956).

expensive and few were built after the 1960s. In most Tower breweries pumping only once elevated the wort. This was usually after separation from the extracted malt when the wort would be pumped to the wort boiler. The wort boiler would be situated at the top of the brewery and then the wort would fall by gravity to the hop separator (hop back) and then to a wort receiver prior to cooling.

These Tower brewhouses were built to be as fire resistant as possible and the use of wood was avoided. The buildings were essentially brick and concrete with steel being used in later developments. One of the essentials of a Tower brewery was a hoist or lift from the bottom to the top of the building. This in itself created a problem for fire prevention and the lift had to be installed in a brick shaft with self-closing doors of sheet iron on each floor.

Tower breweries also had very small vessels by the standards of the late 20th and early 21st centuries. A large wort boiler would be no more than 325 hl (200 imp. brl) in capacity whereas today a wort boiler could have a volume of 1,000 hl (600 imp. brl) or more. In big brewing companies economies of scale tend to demand large vessels and these breweries are often producing huge volumes of one or two brands. A Tower brewery would simply be too expensive to construct to satisfy these requirements. For a modern brewery a horizontal lay-out using cheaper building materials offers a lower-cost solution.

18.2.2 The horizontal brewery lay-out

As often is the case when examining developments in an historical context no system is found to be entirely designed to one set of rules. We therefore have breweries that have partial characteristics of vertical or horizontal design. Small breweries, particularly on mainland Europe, were often of two-vessel design (Fig. 18.2) having one vessel as a mash tun and a separator and a second vessel as a mash cooker and wort kettle. The lay-out of these breweries was usually horizontal. It was natural, therefore, that when these plants were extended to four or more vessels that these were laid out on the horizontal. The construction of the building to house the vessels is made much simpler in this situation. This usually means a steel-framed building with brickwork to first-floor level and then some form of mild steel profile cladding and glass to the upper levels. Fireproofing is simpler and there is no need for a complex design of lift shaft. Costs of construction are much reduced and the money can be spent on ensuring the best quality of vessels, pipework and control systems. The Tower brewery allowed savings in manpower and energy use but this was overtaken by high building costs and the subsequent ease of automation of very large horizontally laid out plant allowed further savings, which more than compensated for any energy increases.

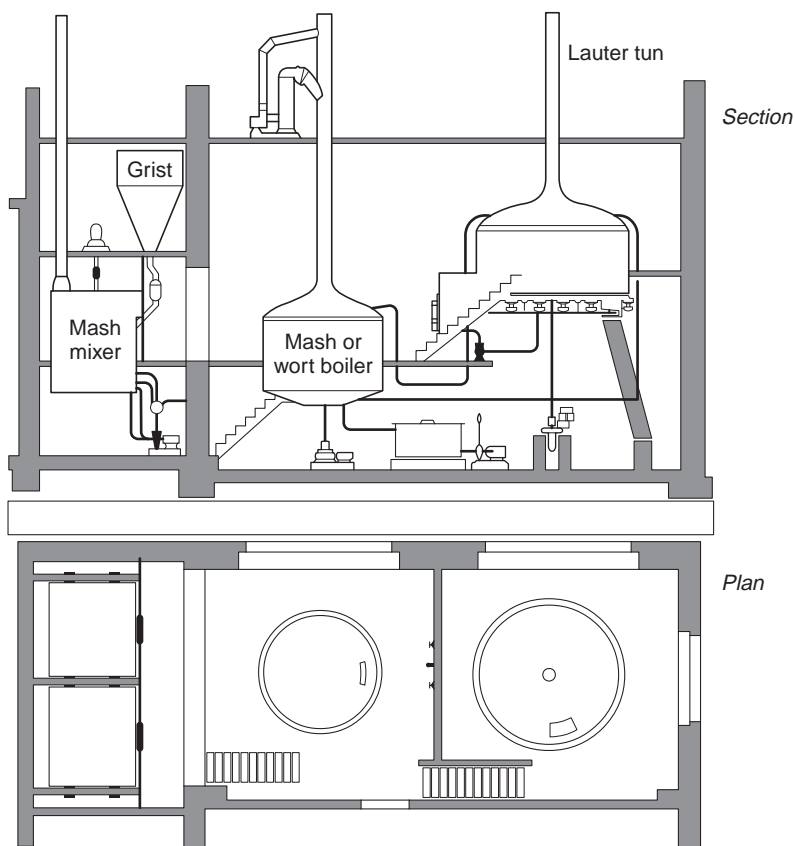

Fig. 18.2 Two-vessel brewhouse with mash mixing vessel on the left, mash and wort boiler in the centre and lauter tun on the right (Briggs *et al.*, 1981).

18.3 Types of modern brewhouses

A modern horizontal brewery will have a combination of vessels:

- a mash conversion vessel or tun
- a mash cooker
- a wort separation device such as a lauter tun or mash filter
- a wort boiler

To these vessels could be added:

- a heated wort buffer tank
- a hop separator such as a whirlpool.

The detailed operation of all these vessels is considered in Chapter 6 and the related science is discussed in Chapter 4. From these Chapters the essential technology of the large modern brewhouse emerges and this is obviously the most significant for brewing: science and practice. Different types of brewhouse are, however, also successful in the 21st century.

Brewhouses have to produce a volume of wort of the right quality to support fermentation as frequently as is required by the market in which the brewing company is operating. This, of course, derives from the brands of beer the brewery is expected to produce. The requirements from a micro- or pub brewery are very different from a brewery producing very large volumes of a national or international brand. A brewery producing high volume brands might be of a size to produce between 3.5 and 10 million hl (2 to 6 million imp. brl) of beer per year. There then would be a range down in size through medium-sized plants of 0.5 to 0.8 million hl (0.3 to 0.5 million imp. brl) to micro-breweries as small as 1,000 hl (600 imp. brl) per year or even less.

All these types of plant are important in the brewing industry of today; this is from where the great variety of beer that we enjoy derives and this has been an important change in the last 20 years. We have seen the emergence of the global brand produced in many countries to very strictly defined principles and the rise of the so-called boutique or niche brands produced to satisfy a very local demand. There have been casualties on the way and many breweries in Europe and North America and other parts of the developed world have closed. There is almost a polarization from the global to the local which large companies try to bridge with the adage ‘think local act global’ but it is often difficult to reconcile these conflicting factors. This has implications for a study of the diversity of brewhouses in the 21st century. The driving force for any business, however, is that it must be financially successful and the yield and quality of wort from a brewhouse is important to both the brewer of the global brand and the micro-brewer serving a very local community.

In large brewhouses (Chapter 6), brewers may be trying to cope with the demands of up to 14 brews in one day. There are very different demands facing brewers operating other brewhouses. These other brewhouses can be broadly categorized as experimental brewhouses and micro- or pub breweries. Beer produced in the former category does not always have to be commercially acceptable whereas beer from a pub brewery must have the highest acceptability. The requirements of the two brewhouses are therefore quite different.

18.3.1 Experimental brewhouses

These brewhouses can be used solely for training purposes or can be used for a combination of training and raw material evaluation and new product development. It is often difficult to flavour match beers produced on the small scale to those produced on

the production plant. New product development, therefore, is frequently carried out on the large scale and is correspondingly very expensive! However, raw material evaluations such as those of malt prepared from a new barley variety or new hop varieties are usually successful. Indeed in the UK, pilot scale trials coordinated by The Institute and Guild of Brewing are crucial in gaining approval of new varieties of both barley and hops. These trials have operated for the last 30 years and have prevented barleys of poor brewing quality becoming widely grown. Beers produced in experimental trials can sometimes be blended back into mainstream brews at say 10% to minimize costs.

Experimental breweries can vary considerably in size. Breweries from 5 to 200 litres have been described (De Clerk and De Clerk, 1965; Baetsle, 1983). And there is also the genuine pilot brewery that can be between 10 and 100 hl in brewlength (Moll and Midoux, 1985). The greater the size means the greater the likelihood results of trial brews will be closer to commercial results. Most international brewers will have pilot plant facilities and all training institutes and research organizations will have this type of equipment. Results must be interpreted with care and the skill and experience of the brewer in charge of the equipment is of major importance. The brewing equipment must be capable of reproducible operation and it is highly desirable to carry out a statistical evaluation so that the value of the least significant difference between the various parameters is known. Only in this way will truly meaningful results be obtained.

18.3.2 Micro- and pub breweries

The international brands of beer are highly specified and extremely consistent. To ensure this consistency and to provide the reproducibility necessary to brew the beers all over the world these beers tend not to have strong flavours. They tend to be bland and in particular have low bitterness and lack hop character. The international brands are also tending to taste more and more similar. Beer drinkers now demand more choice in their beers and have looked for more original flavours, usually with higher levels of bitterness. This has been particularly driven by changes in the USA (Lewis and Lewis, 1996) since 1985 when the micro-breweries started to emerge. This was partly as a result of legislation in 1982 that legalized 'Brewpubs'. Micro-brewing in the USA still occupies a small volume but it has grown at 50% per year since 1985 to take over 2% of the whole market. The structure of the industry is complex with a large variation in the size of individual companies but genuine micro-brewers are driven by real passion for what they do. Consequently their enthusiasm has had an impact on the major brewers who have sought to cash in on market opportunities by introducing their own boutique brands often under disguised labelling. This has further fuelled competition and development. The strongest markets for micro-brewers in the USA are in California, Oregon, New England and Florida.

Most micro-breweries in the USA use infusion mash tuns for extraction of the malt and wort separation. This equipment is relatively low cost and allows a link to the British tradition of ale brewing. Indeed this is the normal choice throughout the world. Frequently the brewing equipment is on display to the public consuming the beer. The breweries vary considerably in size often from about 10 to 50 hl (6 to 30 imp. brl) in brewlength with three to five brews per week. Consumers will tolerate some variation in the beer in the interests of presumed authenticity but will not tolerate any hint of infection. Sanitation and microbiological control in these breweries is therefore of paramount importance and if this fails then this is the most frequent cause of unacceptable beer. Modern micro-brewing apparatus usually has associated CIP equipment and this must be used rigorously. Yeast must also be checked before pitching

Table 18.1 Comparison of analyses of generic national lager and generic micro-brewed lager in the USA (Lewis and Lewis, 1996)

Parameter	National lager	Micro-brewed lager
Original gravity (°P)	11.5	15.5
Alcohol by weight (%)	3.8	6.0
Bitterness (IBU)	12	35
Colour (°EBC)	4	25

Table 18.2 Japanese consumption and market share of beer and happoshu (Malone, 2001)

Volume (000 hl)	1996	1997	1998	1999	2000
Beer & happoshu	72,485	72,095	72,351	72,264	71,764
Beer	69,770	67,929	62,561	58,327	55,510
Happoshu	2,715	4,167	9,790	13,937	16,254
Market share (%)	1996	1997	1998	1999	2000
Beer	96	94	87	81	77
Happoshu	4	6	14	19	23

for purity. Bottling equipment is often of poor quality. In addition to ensuring that it is effectively cleaned, every effort must be made to limit the occurrence of headspace air that has exceeded 4 ml in some cases with disastrous consequences causing oxidation and rapid flavour deterioration. Micro-brewed beers are often prepared with 100% malt and as such may be inherently less stable than national beers. This is sometimes offset by their normally much higher hop content (Table 18.1).

There have been some interesting developments in Japan (Malone, 2001), where a mature beer market was in need of some innovation. The licensing laws in Japan were changed in 1994 allowing breweries to make a minimum of 600 hl (360 imp. bbl) of beer per year. There are now around 300 small breweries producing local beer (*ji-biru*). To some extent growth of these breweries has been stimulated by the growth of local sake breweries (*ji-zake*). There has also been very significant growth in 'happoshu' (sparkling drinks). These products have less than 25% malt in the grist and are subjected to much lower rates of duty. The drinks thus retail at lower prices and have grown in popularity (Table 18.2). This has created a market opportunity for more flavoursome micro-brewed beers that will grow, particularly if the Government moves to reduce the differences in duty payments between happoshu and beer.

The majority of the small breweries in Japan produce top-fermented beers but some have tried to produce German-style lagers in this way and have found this difficult, with dire commercial consequences. A shakeout of breweries is now under way but it seems likely that growth above the current 0.5% market share of *ji-biru* will continue. Throughout the world the most successful micro-breweries tend to be those producing draught products for consumption with a very short shelf-life of no more than four weeks. Problems arise when producing small pack products and trying to extend the shelf-life to six months and beyond. This usually results in oxidized beers that fail dismally when compared to beers brewed in large breweries. This comparison is best avoided. Micro- and pub-brewed beers taste best when drunk fresh and this is the unique selling point to exploit. The most successful of these operations keep things simple and use a two-vessel brewery with a mash tun and a kettle that can double as a mash kettle and wort kettle as necessary.

As the 21st century progresses it will be interesting to see how the micro-brewing industry develops. International brands of beer will continue to be heavily advertised throughout the world. To compete, local beers will need to be brewed in scrupulously clean plants by dedicated, well-trained professionals, they will have strong and characteristic flavours and be drunk as fresh as is possible.

18.4 Control of brewhouse operations

A key feature of any good brewhouse is reproducibility. An environment must be provided in which the biochemical reactions can take place in a controlled and optimized way. This was originally achieved by close operator involvement in constant checking of times and temperatures and taking remedial action where appropriate. Things are now different. There are very few operators, maybe only two on a 12-hour shift scheduled for 12 brews a day, and they are likely to be led by a team leader controlling the whole of the process from raw material intake to the end of fermentation. The departmental manager may be a remote figure frequently most concerned with achieving the financial plan targets and writing the monthly report.

18.4.1 Automation in the brewhouse

In this increasingly common situation automation of the sequence of brewhouse operations is indispensable. This automation is no substitute for the brewhouse operator knowing what is happening in the vessels and his training in this respect is crucial. Very expensive mistakes can ensue if automation is slavishly followed when things are going wrong. The big change in automation in the last 20 years has been the gradual replacement of hard-wired relay logic systems with the silicon chip based programmable logic controllers. This has been coupled with the very rapid development of personal computers (PCs), which has provided user-friendly operator interfaces and the ability to store huge amounts of data. Concurrent with all this have been big reductions in the capital cost of equipment, as the 'Microsoft' operating systems have come to dominate the world. The developments in PCs have facilitated and made cheaper industrial systems' development in what has truly been a buyer's market. A major problem is that systems have advanced so fast that obsolescence has become a factor that the brewer cannot ignore. The language of the control systems expert has also become difficult and obscure for the brewing technologist and this has sometimes led to increased expense when supplier and customer have not understood one another. The old adage, 'the customer is always right' still holds but it is imperative in this area that the customer sets out very precisely what is required of the system he is buying. There is no substitute for the 'Design Brief' and the 'User Requirement Specification', which must form the basis of the Contract. The brewer (the customer) should remain the most important person in the deal.

Systems are usually designed bespoke and are not universal. However it is possible to make some comment on the most successful systems. The way the system is put together is called architecture, which describes the links through from plant level to a management information system (MIS). Several important steps can be recognized.

Sensors

The success of the system, of course, starts with measurements. No amount of clever software will make up for an inaccurate or imprecise measurement. The quality of the

initial measuring is paramount. Fortunately, in the brewhouse we usually want to measure temperature, pH value and pressure and equipment for these measurements is cheap and reliable.

Programmable logic controllers (PLCs)

The control at plant level is effected through PLCs. The PLC is a computer that is programmed to handle simple input and output instructions, e.g., ‘open’, ‘close’. Inputs are the signals from sensors and outputs are the instructions to the machines; pumps, motors, valves, etc. Normally a brewery company will specify one type of PLC from one manufacturer and this is highly desirable for consistency over the whole brewery site and for future changes to the system.

Supervisory control and data acquisition systems (SCADA)

PLCs link machines together and send out simple instructions to make changes in the process according to how they have been programmed. The operator requires information on what is happening and needs to store information for future use. This is provided through a SCADA system that can communicate with PLCs by an industrial Ethernet. The SCADA system can now have a very user-friendly interface through a PC (which can use familiar Microsoft Windows NT software) in the brewhouse. The SCADA system can also be linked to high-level MIS that can further be linked nationally or even internationally providing Head Office with direct access to an individual brewery.

It is now possible to use this system architecture to hold the recipes of the brewing process and to schedule the brewhouse operations (Cooper *et al.*, 2002). A series of reports can be obtained that could detail actual achieved mash temperatures, transfer times and run-off profiles, etc. Studying these reports allows predictions to be made and correlations to be sought which can lead to future brewhouse improvements.

All these developments make the operation of the brewhouse easier to control in these days of very low manpower levels. It must again be stressed how important the training of the operator is so that timely intervention may be made when indicated by the control system. The development of the qualification the ‘General Certificate in Brewing and Packaging’ (formerly the Foundation Certificate) by the Institute and Guild of Brewing is a particularly important step in this respect (Brookes, 1999).

18.4.2 Scheduling of brewhouse operations

The brewhouse is the most important part of the brewery in relation to its overall capacity. The number of brews that can be carried out in one day and the length of the brewing week are the relevant factors. Different businesses will have very different requirements. The driving force for the micro- or pub brewery will be to have the beer presented to the customer in the pub in the freshest possible state. There will be seasonality here and the micro-brewer will need to be able to increase production in the summer to meet demand. However it is unlikely that there will be more than two or three brews performed in one day and the brewing week will probably be five days but those days may include the weekend so as to ensure maximum exposure to the public if brewing vessels are on view. This will give two days for thorough cleaning which is essential to maintaining product quality.

The situation is very different in the large brewery producing national or international brands. It is now frequently the case that beer will not be delivered direct to the customer from the brewery but will go to a regional distribution centre where stock will be held

(Chapter 22). The brewery's staff often feels remote from the customer in this situation. The brewery's success will be measured against its ability to produce beer to a plan and this plan will be derived from historical sales data and marketing forecasts. The plan will often be given to the brewery from a central planning department who will monitor progress. The role of the brewery is clear. It must deliver the plan.

The core of the plan then will be the number of brews that can be consistently delivered from the brewhouse. Working arrangements in the brewhouse will probably be based on some form of 168-hour cover where teams will cover the whole week and take rest days on a rotating basis. The weekends are not significant since any overtime payments are likely to be built in to an overall salary for the job. This makes scheduling easier. However, it is still very important to build in to the programme sufficient time for cleaning, maintenance and calibration of plant and it is unlikely that the plan will demand more than six-day brewing. There will also be time needed for maintenance and six-day brewing cannot be sustained indefinitely. Trade is usually such that there is considerable seasonality in demand with peak brewing being required in the summer and at national holiday periods or periods of Company sponsorship of major events such as football championships. These external factors become the driving force to the plan and influence the calculation of brewhouse capacity. The maximum capacity of the brewhouse will be the number of brews in a day \times length of brewing week \times number of weeks of brewing in a year. To be prudent in calculating seasonality we might express the foregoing as $10 \times 6 \times 46 = 2,760$ brews per year. The planning department would build this information into its model of operations and hence the production and distribution plan would be derived.

The actual volume of beer produced depends, of course, on the strength of wort delivered from the brewhouse and the amount of post-fermentation dilution carried out. This relates to the types of beer being brewed and the nature of the grists. Scheduling of brewhouse operations will usually include scheduling the intake of raw materials and this will also frequently be arranged centrally in large brewing groups. To service a large brewery as illustrated above, considerable quantities of raw materials will require to be delivered each week:

Let us assume that each brew is 1,000 hl (≈ 600 imp. brl) at a gravity of 1048° (48°Sacch, 12°P). Let us also assume that the grist is 90% white malt and 10% sugar (Section 18.5). Each brew will require approximately 15 tonnes of malt and 1.5 tonnes of sugar solution. For a six-day week at ten brews per day this amounts to 900 tonnes of malt and 90 tonnes of sugar per week therefore we require around 36 loads of malt and 4 loads of sugar solution per week.

This represents a considerable scheduling operation and requires close liaison between the maltster, the sugar supplier and the brewer. To be prudent the brewer will probably want to hold at least one week's stock of raw materials on site and so will require at least ten 100-tonne malt bins and three to four 20-tonne sugar tanks. Of course there may also be a requirement for delivery and storage of smaller quantities of special malts and mash tun adjuncts (see Chapter 5).

In recent years this whole subject has received much attention from planners and software experts and computer systems with the general title of materials requirements planning (MRP) and the further development of manufacturing reserve planning (MRPII) are now commonplace. The objective is to pick up the principles of 'just in time' (JIT) production to minimize the stock holding of raw materials, those in-process and finished beer in the brewery. This in turn reduces working capital. Software systems in use include PRMS, PRISM and SAP. These systems can be extremely useful particularly in providing

information to suppliers of raw materials. But they are no substitute for physical stock checks in the brewery to ensure that the materials required and apparently in stock are actually present!

18.5 Economic aspects of brewhouses

Fixed costs in breweries relate to manpower, utilities, repairs and depreciation and other costs such as rates and other local taxes. Variable costs relate to the efficiency in the use of materials and losses of product incurred during processing. Of prime importance to the efficiency of the brewhouse then, and hence to brewery variable cost, is the quantity of soluble material extracted from the grist. The more efficient this process the greater will be the contribution to the fixed costs of running the brewery, where contribution is defined as the income less the variable costs (sometimes called gross profit).

The strength of wort is, of course, judged by the quantity of material in solution, the extract. This is usually measured as the specific gravity relative to water at a specific temperature (see also Chapter 4), or by relating to the concentration (%w/w) of a sucrose solution having the same specific gravity using the scales of Balling or Plato. A pale malt ground and extracted in cold water will yield 16–22% of its dry matter as soluble extract (the cold water extract, Chapter 4). The same malt ground and extracted at 65 °C (149 °F) will yield 75–83% of its dry matter as extract (the hot water extract). The extra substances yielded by hot water mashing derive from enzymic attack on initially insoluble materials, mainly starch. This forms the nub of potential economic improvement in the brewhouse. If increases in soluble extract can be consistently achieved then there will be reductions in the raw material bill, lower variable cost and brewhouse operations will be judged a financial success. Consider the preparation of 1,000 hl of wort at a gravity of 1,048° (48°Sacch, 12°P), from a grist of 90% white malt and 10% sugar:

Let the extract of the white malt be 300 l°/kg (as is). Let the extract of the sugar solution be 320 l°/kg (as is). Let the extract efficiency of the brewhouse be 97% (i.e. in normal circumstances, 97% of the extract as indicated by laboratory analysis would be expected to be extracted into brewery wort). The amount and strength of wort to be collected is:

$$1000 \times 48 = 48,000 \text{ hl}^\circ (4,800,000 \text{ l}^\circ)$$

the quantity of materials required will be:

$$\text{white malt } (4,800,000 \times 0.9) \div 0.97 \div 300 = 14,845 \text{ kg}$$

$$\text{sugar } (4,800,000 \times 0.1) \div 320 = 1,500 \text{ kg}$$

The sugar is not affected by the 97% extract recovery because it is added directly to the wort boiler and is assumed to be utilized at 100%. Clearly, if the extract efficiency can be consistently raised to 98% then 1% less malt will be required, i.e., 148 kg of malt less. Over the course of 2,000 brews in a year this would amount to around 300 tonnes of malt, which could equate to variable cost savings of around US \$96,000 per year. This is a considerable sum and illustrates the great importance of striving to achieve consistent improvement in brewhouse performance by achieving operating conditions to optimize enzyme activity.

18.6 Summary

Brewhouses are the heart of every brewery whether large multi-national or niche brand pub brewery. It is the extraction of the grist that is crucial to economic success and to yeast performance and beer quality. Brewhouses can be of different types and large brewhouses are capable of being operated with high efficiency and consistency whilst small brewhouses are capable of being controlled to yield worts for beers with unique and stronger flavours. Further improvements are likely to be restricted by the amount of money now being invested in basic research. In the long run this will be a short-sighted policy. The long-term winners will be those organizations that invest in studying how enzymes cope best with the heterogeneous conditions of the brewery mash.

18.7 References

- ANDERSON, R. G. (1993) *Ferment*, **6**, 191.
- BAETSLE, G. (1983) *Cerevisia*, **7**, 11.
- BRIGGS, D. E., HOUGH, J. S., STEVENS, R. and YOUNG, T. W. (1981) *Malting and Brewing Science Volume 1, 2nd edn*, Chapman and Hall, London and New York.
- BROOKES, P. A. (1999) *Proc. 7th. Conv. Inst. Brew. (Africa Section), Nairobi*, xiii.
- COOPER, T. J., BARNES, Z. C. and MCFARLANE, I. K. (2002) *Proc. 27th Conv. Inst. Brew. (Asia Pacific Section), Adelaide*, 1.
- DE CLERK, J. and DE CLERK, E. (1965) *Tech. Quart. MBAA.*, **2**, 183.
- JEFFERY, E. J. (1956) *Brewing, Theory and Practice*, Nicholas Kaye, London, 18.
- LEWIS, M. J. and LEWIS, D. J. (1996) *Proc. 6th Int. Brew. Tech. Conf., Harrogate*, 227.
- MALONE, R. (2001) *Brewers' Guard.*, **130(9)**, 24.
- MOLL, M. and MIDOUX, N. (1985) *Tech. Quart. MBAA.*, **22**, 67.

Chemical and physical properties of beer

19.1 Chemical composition of beer

Beer, the final product of the brewing process, is designed to be drunk. It is a complex mixture; well over 450 constituents have been characterized, and, in addition, it contains macromolecules such as proteins, nucleic acids, polysaccharides and lipids. Together all these constituents produce the character of beer. In this chapter we review the compounds that have been found in beer but delay discussion of the influence they have on beer flavour until the next chapter. However, to prevent duplication, data on the taste thresholds of the compounds found are included in the Tables given in this Chapter. A useful introduction is given in the monograph *Beer: Quality, Safety and Nutritional Aspects* (Baxter and Hughes, 2001). Jurado has reviewed beer styles and provided analyses for Pilsener (2002a), Munich Helles (2002c), brown ales (2001a), strong ales (2002e), pale ales (incl. IPA) (2002e), red beers (2002b), wheat beers (2001b) and seasonal and special beers (2002d). The ranges of analytical values found are collected in Table 19.1. A. Piendl (Weihenstephan) has published analyses of beers from all over the world. In most cases the units used by the authors quoted have been retained. It is often not known whether parts per million (ppm) is mg/l or mg/kg. Parts per billion (ppb) is parts per 10^9 ($\mu\text{g/l}$ or $\mu\text{g/kg}$).

Beer constituents can be divided into volatile and non-volatile components. The volatile components have greater vapour pressure and are responsible for the bouquet or aroma of beer. They are concentrated in the headspace above the liquid in a closed container and will pass into the distillate if the beverage is distilled. The complex mixture of volatile components either in the headspace or in a solvent extract of the beer can be resolved by gas-liquid chromatography, using either packed or capillary columns, and the components identified by mass spectrometry (GC-MS). The non-volatile constituents include inorganic salts, sugars, amino acids, nucleotides, polyphenols and hop resins together with macromolecules such as polysaccharides, proteins and nucleic acids. Such compounds are usually resolved by high precision liquid chromatography (HPLC). Before the advances in chromatography available today, brewers developed numerous methods of analysis to control their process and the quality of their products and many of

Table 19.1 Beer analyses

	100% Malt Pilsener	Munich-style Helles	Brown ales	Strong ales	IPA	Pale ales	Red beers	Wheat beers	Seasonals and specials
Ref.	Jurado (2002a)	Jurado (2002c)	Jurado (2001a)	Jurado (2002e)	Jurado (2002e)	Jurado (2002e)	Jurado (2002b)	Jurado (2001b)	Jurado (2002d)
No. of samples	18	33	22	8	17	58	23	27	34
Specific gravity	1.00682–1.01411 (1.009740)	1.00258–1.10166 (1.01485)	1.00599–1.01991 (1.0132)	1.00676–1.02715	1.00739–1.01646	1.00471–1.01680	1.00627–1.01986 (1.01236)	1.00449–1.02385 (1.01326)	1.00342–1.03471
Apparent extract	1.75–3.60 (2.48)	0.66–3.31 (2.04)	1.54–5.06 (3.36)	1.73–6.86	1.89–4.19	1.21–4.83	1.61–5.04 (3.15)	1.15–6.04 (2.67)	1.57–8.71
Alcohol (% w/w)	3.05–4.66 (4.30)	3.26–4.81 (4.11)	2.11–5.02 (3.97)	4.02–8.00	2.25–7.26	2.93–5.89	3.17–6.28 (3.88)	3.03–6.51 (4.04)	1.46–5.63
Real extract (% w/w)	3.52–5.17 (4.30)	2.64–4.89 (3.92)	3.58–6.88 (5.20)	4.65–10.24	3.31–6.92	2.80–6.83	3.31–6.77 (4.93)	2.91–7.46 (4.53)	2.75–9.37
Original gravity (°P)	10.87–13.06 (11.97)	9.88–13.50 (11.89)	7.77–15.5 (12.855)	12.43–24.50	7.78–20.35	8.99–17.50	9.81–18.42 (12.42)	10.01–19.32 (12.34)	8.0–17.0
Real degree of fermentation	56.0–70.2 (65.4)	59.2–76.4 (68.4)	52.1–71.2 (61.194)	56.8–74.8	58.2–70.8	53.4–76.6	52.7–71.0 (62.0)	45.6–72.9 (65.0)	24.3–75.9
Calories	143.6–172.0 (158.0)	63.5–178.6 (156.2)	102.2–209.8 (171.9)	165.0–346.6	124.2–278.5	125.7–238.5	127.6–250.8 (165.7)	130.2–264.8 (163.7)	106.0–230.5
pH	3.74–4.63 (4.33)	3.99–4.77 (4.37)	3.95–4.56 (4.33)	3.81–4.83	3.87–4.74	3.78–4.64	3.86–4.99 (4.21)	3.66–4.82 (4.46)	3.14–4.60
Colour (Lovibond)	2.9–8.8 (6.0)	3.1–15.3 (4.2)	18.4–58.9 (32.8)	14.9–47.4	6.7–26.0	4.1–52.5	9.4–54.4 (23.9)	3.8–49.0 (11.2)	4.4–68.7
Bitterness (IBU)	3.1–51.2 (31.0)	13.7–30.5 (18.4)	13.5–44.7 (26.6)	15.4–67.3	24.3–78.6	6.5–67.2	12.4–35.5 (21)	8.2–33.9 (17.2)	7.5–42.2
Vicinal diketones (ppm)	0.01–0.04 (0.0)	0.01–0.09 (0.04)	0.01–0.25 (0.04)	0.03–0.29	0.01–0.20	0.01–0.22	0.01–0.16 (0.04)	0.01–0.38 (0.05)	0.01–0.22
Sodium (Na, ppm)	3–45 (34)	11–50 (26)	21–106 (39)	24–322	14–113	13–123	17–100 (43)	14–86 (43)	13–150
Dimethyl sulphide (ppb)	3–73 (50–55)	–	–	–	–	–	–	–	–
SO ₂ (ppm)	–	0–3.2	–	–	–	–	–	–	–

Table 19.2 Analyses of British beers (Anon., 1960, 1967)

Quality	OG	Alcohol (% v/v)	Unfermented matter (%)	Isohumulones (mg/l)
Draught bitter	1030.9–1045.3	3.0–4.6	27–45	20–40
Draught mild	1030.7–1036.5	2.5–3.6	29–48	14–37
Light ale (bottle or can)	1030.6–1038.9	2.9–4.0	30–40	16–38
Best pale ale	1040.3–1050.3	4.3–6.6	21–43	19–55
Brown ale	1030.2–1040.6	2.5–3.6	43–55	16–28
Stout – Guinness	1040.0–1046.1	4.4–5.1	30	55–62
– Mackeson	1044.3–1047.6	3.7–3.8	49	27–31
Strong ales	1065.9–1077.7	6.1–8.4	32–44	25–43
Lagers	1029.7–1036.3	3.3–3.6	35–39	20–32

these are retained in *Analytica-EBC* and by the Institute of Brewing and the American Society of Brewing Chemists (Section 1.15.1, p. 9). Some representative analyses are given in Tables 19.1 and 19.2.

Another way to classify the organic constituents of beer is with reference to the heteroatoms present. Beers contain only trace amounts of hydrocarbons, the majority of the constituents contain carbon, hydrogen and oxygen. Small amounts of nitrogen-containing constituents are present of which the proteins are important for the physical properties of beer. Only low levels of sulphur-containing compounds are found but volatile sulphur compounds have low thresholds and so small amounts can influence the flavour of beer. Indeed, abnormally high levels of sulphur compounds can be responsible for off-flavours. Volatile sulphur compounds can be examined by gas chromatography using either a flame photometric detector or a Sievers' chemiluminescent detector both of which are specific for sulphur-containing compounds. In general different beers contain different proportions of the same constituents. Only when novel raw materials are used will novel constituents be found in the beer as, for example, Belgian fruit beers such as Framboise. However, accidental or deliberate contamination of wort or beer with foreign micro-organisms may well produce new metabolites and flavours.

19.1.1 Inorganic constituents

The most abundant constituent of beer is water, the medium in which, in bright beer, all the other constituents are dissolved. Brewing liquor normally contains only trace amounts of organic matter and the desirable cations and anions required in the liquor are reviewed in Chapter 3. During the brewing process other salts will be extracted from malt and hops, some ions may be precipitated on the break and others may be absorbed by the yeast so that the inorganic salts present in beer are very different from those in the liquor used. Data for the inorganic constituents of beer are collected in Table 19.3.

The major ions are the cations potassium, sodium, calcium and magnesium and the anions chloride, sulphate, nitrate and phosphate. There are agreed international methods for measuring sodium, potassium, calcium and magnesium in beer by atomic absorption spectroscopy. In addition the ASBC gives methods for determining calcium and magnesium by titration with EDTA. International methods are also available to determine the anions in beer, chloride, sulphate, nitrate and phosphate by ion chromatography. There is also an international method for chloride by conductometry, and *Analytica-EBC* gives a gravimetric method for sulphate and an enzymatic method for nitrate. Excess nitrate in beer is undesirable as potentially nitrates can be reduced to nitrites, which with

Table 19.3 Inorganic constituents of beer

Constituent	Source	Concentration range mg/l (ppm)*	Reference
Aluminium	German	0.1–1.24	Postel <i>et al.</i> (1983)
Arsenic	Lagers	0.02	Binns <i>et al.</i> (1978)
	Spanish	3.1–8.2	Cervera <i>et al.</i> (1989)
	Others	1.8–11.2	Cervera <i>et al.</i> (1989)
Cadmium	German	0.0002–0.020	Postel <i>et al.</i> (1983)
	Spanish	0.031–0.397	Ybáñez <i>et al.</i> (1989)
	Others	0.095–0.677	Ybáñez <i>et al.</i> (1989)
Calcium	British	40–140	Paul and Southgate (1978)
	German	3.8–102 (32.7)	Postel <i>et al.</i> (1974)
	Lagers	10–135 (36)	Binns <i>et al.</i> (1978)
Chromium	European	(0.0072)	Robberecht <i>et al.</i> (1984)
	Spanish	0.004–0.022	Farre <i>et al.</i> (1987)
Cobalt	Spanish	0.00005–0.00079	Ybáñez <i>et al.</i> (1989)
	Others	0.00005–0.00038	Ybáñez <i>et al.</i> (1989)
Copper	British	0.3–0.8	Paul and Southgate (1978)
	German	0.04–0.80 (0.19)	Postel <i>et al.</i> (1972b)
		0.02–1.55	Postel <i>et al.</i> (1983)
	Spanish	0.0064–0.0603 (0.029)	Ybáñez <i>et al.</i> (1989)
	Others	0.010–0.040 (0.027)	Ybáñez <i>et al.</i> (1989)
Iron	Lagers	0.01–0.41 (0.11)	Binns <i>et al.</i> (1978)
	British	0.1–0.5	Paul and Southgate (1978)
	German	0.02–0.84 (0.02)	Postel <i>et al.</i> (1972a)
		0.04–1.55	Postel <i>et al.</i> (1983)
	Lagers	0.04–0.44 (0.12)	Binns <i>et al.</i> (1978)
Lead	Wheat beer	(0.63)	Postel <i>et al.</i> (1972a)
	German	0.003–0.024	Postel <i>et al.</i> (1983)
	Spanish	0.0014–0.0056 (0.0028)	Ybáñez <i>et al.</i> (1989)
	Others	0.0008–0.0025 (0.0017)	Ybáñez <i>et al.</i> (1989)
	Lagers	0.06	Binns <i>et al.</i> (1978)
Magnesium	British	60–200	Paul and Southgate (1978)
	German	75–250 (114)	Postel <i>et al.</i> (1974)
	Lagers	34–162 (82)	Binns <i>et al.</i> (1978)
Manganese	German	0.04–0.51 (0.20)	Postel <i>et al.</i> (1973)
Mercury		0–0.0008	Donhauser <i>et al.</i> (1987)
Nickel		0–0.26	Brenner <i>et al.</i> (1965)
Phosphorous	British	90–400	Paul and Southgate (1978)
	Australian	96–304 (196)	Bottomley and Lincoln (1958)
Potassium	British	330–1100	Paul and Southgate (1978)
	German	396–562 (476)	Kieninger (1978)
	Mexican	220–358	Canales <i>et al.</i> (1970)
	Lagers	253–680 (362)	Binns <i>et al.</i> (1978)
Selenium		0–0.0072 (0.0012)	Donhauser <i>et al.</i> (1987)
Silicon		10.2–22.4	Anderson <i>et al.</i> (1995)
Sodium	British	40–230	Paul and Southgate (1978)
	German	9–120 (35)	Kieninger (1978)
	Lagers	15–170 (58)	Binns <i>et al.</i> (1978)
Tin	German	0.010–0.020	Postel <i>et al.</i> (1983)
Zinc	German	0.01–1.48 (0.10)	Postel <i>et al.</i> (1975)
	Lagers	0.01–0.46	Binns <i>et al.</i> (1978)
	German	0.01–0.26	Postel <i>et al.</i> (1983)
ANIONS			
Chloride	British	150–984	Paul and Southgate (1978)
	German	143–365 (210)	Kieninger (1978)

Table 19.3 Continued

Constituent	Source	Concentration range mg/l (ppm)*	Reference
Fluoride	British	0.08–0.71	Warnakulasuriya <i>et al.</i> (2002)
	German	0.08–0.64 (0.15)	Postel <i>et al.</i> (1976)
Nitrate	German	1.4–101.3 (34.0)	Postel (1976)
	German	13–43	Gmelch <i>et al.</i> (1989)
Phosphate	British	260–400	Paul and Southgate (1978)
	German	624–995 (860)	Kieninger (1978)
Sulphate	British	150–400	Paul and Southgate (1978)
	German	107–398 (182)	Kieninger (1978)
	African lager	125–260	Shah (1975)

* Average values in parentheses.

amines can form carcinogenic *N*-nitrosamines (see later). The EEC limit for nitrates in drinking water is 25 mg/litre.

Trace amounts of many metals are essential for yeast growth whereas larger amounts may be toxic and may be limited by law. When specific limits for beer are not specified the limits for potable water are usually applied. In Britain, the levels of arsenic and lead are limited to 0.2 mg/kg (ppm) and the Institute of Brewing describes methods for ensuring these limits are met. International methods for determining iron, copper and zinc by atomic absorption spectroscopy are published as well as spectrophotometric methods for iron and copper. The UK Food Standards Committee recommends a limit for copper in beer of 7.0 mg/kg. Nickel can be estimated in beer spectrophotometrically by measuring the colour formed with dimethylglyoxime (*Analytica-EBC*). In the 1960s cobalt was added to beer to improve foam stability and prevent gushing. However, this was found to cause acute heart disease in heavy drinkers (in excess of 20 pints beer/day) so the practice was discontinued (Long, 1999).

Carbon dioxide is a natural product of fermentation and beers contain 3.5–4.5 g/l. Supersaturated beers and naturally conditioned beers may contain as much as 6 g/l but gas will be evolved as soon as the pressure is released. The sensory threshold of carbon dioxide is about 1 g/l so the amount present will influence the flavour of beer. *Analytica-EBC* describes a titrimetric and an instrumental method for measuring the amount of CO₂ present. The Institute of Brewing describes a manometric method and the ASBC gives two methods, one for beer in tanks and the other for beer in bottles or cans.

19.1.2 Alcohol and original extract

In the European Economic Community (EEC) the strength of beer and other alcoholic drinks, is expressed as alcohol by volume (ABV), that is the ratio of the volume of the ethyl alcohol contained in the liquor to the volume of the liquor including the ethyl alcohol (expressed as a percentage to one decimal place). Further the EEC directed in 1987 that the ABV 'alc x.y% vol' shall appear on the label. In many countries excise duty is levied on the basis of the ABV. In Britain duty is payable on beers with more than 1.2% ABV. Before 1993 duty in Britain was calculated from the original gravity of the wort fermented. Beers can contain between 0.05% ABV, in an alcohol-free beer, up to about 12.5%. In Germany bock beers must contain more than 6.0% ABV and double-bock beers more than 7.5% ABV. According to Glaser (2002), the strongest beer is Utopias MM II with 24% ABV. *Analytica-EBC*, the Institute of Brewing and the ASBC

provide several methods for measuring alcohol in beers but national Excise authorities may specify their own modifications.

The distillation method is usually regarded as the reference method to be used in any cases of dispute. Here an accurately measured quantity of filtered beer (say 100.0 ml in a volumetric flask at 20 °C or 100.00 g) is washed into a suitable distillation flask (400–500 ml capacity) and distilled, taking care not to char the residue in the distillation flask, until c. 85 ml is collected (in the same volumetric flask). This is then made up to 100.00 ml (or 100.00 g) and the specific gravity in air at 20 °C/20 °C is measured in a suitable pycnometer (Reischauer) or specific gravity bottle to five places of decimals. A Paar densitometer or a similar instrument, which make this measurement electronically is now commonly used (see IoB, ASBC, Mundy, 1996). Several tables exist to convert the specific gravity of the distillate to give the alcohol content. The EEC recommend that the tables of the Organisation Internationale de Metrologie Legale (OIML) should be used but they refer to specific gravity *in vacuo*. The EBC has therefore provided an alcohol table based on the specific gravity measured in air and give polynomials for alcohol and extract (Rosendahl and Schmidt, 1987):

$$A\% \text{ m/m} = 517.4(1 - SG_A) + 5084(1 - SG_A)^2 + 33503(1 - SG_A)^3$$

where A is % alcohol by weight and SG_A is the specific gravity of the distillate in air at 20 °C/20 °C.

To convert A% m/m to A% v/v (ABV):

$$\text{Alcohol \% v/v} = \frac{A\% \text{ m/m} \times SG_A}{0.791}$$

where 0.791 is the specific gravity of ethanol at 20 °C/20 °C.

The American Society of Brewing Chemists and the British Excise Authorities provide their own tables (for part of the latter see Table 19.4).

Alcohol may also be determined by catalytic combustion using a Servochem Automatic Beer Analyser (SCABA). The injected beer is divided into two streams, one enters a Paar U-tube densitometer, the other passes down a column as a falling film where the alcohol is removed as a vapour with a countercurrent of air and passed over an alcohol sensor. After calibration with known standards, the onboard computer will display the % alcohol either m/m or v/v when the results are found to agree with the distillation method (Freeston and Baker, 1993). Schropp *et al.* (2002) evaluated an NIR procedure for measuring the alcohol content as in the *Alcolyzer* instrument.

The amount of alcohol present can also be determined from the refractive index of the media. This is much quicker than the distillation method but requires standardizing to determine the constants A, B, and C in the regression equation:

$$\text{Alcohol \% (v/v)} = A(\text{SR} - \text{WR}) - B(\text{PG}) - C$$

where SR is the refractive index of the beer, WR is the refractive index of water, and PG is the present gravity of the beer $\{1000(SG - 1.00000)\}$. The instrument is thermostatted and measurements are usually made at 20 °C. Ethanol can also be determined by gas chromatography using a flame ionization detector and direct injection on to a suitable column (Poropak Q, 15% Carbowax 20 M, SGE BP20 or CP Wax 52 CB), after a known addition of *n*-butanol as an internal standard. The amount of alcohol is calculated by comparison of the peak areas (see also Clarkson *et al.*, 1995).

For alcohol-free or low-alcohol beers (< 0.008%) an enzymatic method is given based on the Boehringer test kit. The alcohol is oxidized first to ethanal and then to ethanoic

acid with nicotinamide adenine dinucleotide (NAD^+) and the reduction of the cofactor is measured spectrophotometrically at 340 nm:

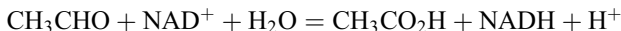

As mentioned above, duty in the United Kingdom used to be levied on the gravity of the wort fermented. Accordingly the Institute of Brewing provide a method to determine the original gravity and *Analytica-EBC* and the ASBC give a method to find the original extract. Both are based on the distillation method for alcohol when, as well as the distillate, the residue in the distillation flask is diluted to the original volume and the specific gravity is measured. In the British method, the number of degrees of gravity by which the distillate is less than the specific gravity of distilled water is called the spirit indication of the distillate. From the 'Mean Brewery Table' (Thorpe and Brown, 1914; HM Customs and Excise, 1997; Statutory Instrument No. 1146, 1979) the degrees of extract that must have been fermented to produce the spirit indication is read off and added to the gravity of the residue to give the original gravity. Such a Table is necessary because in any fermentation carbohydrate is used for yeast growth and the production of metabolites other than ethanol, so the yield of ethanol is always less than that predicted by Gay-Lussac's equation:

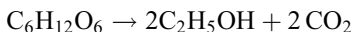

Any radical change in the ratio of yeast growth to alcohol production from that used in compiling the 'Mean Brewery Table' could result in beers in which the original gravity, determined by the above method, is higher than that actually employed. Thus, the use of larger fermentation vessels and methods of continuous fermentation results in beers in which the measured OG is higher than the gravity of the wort employed. Similarly, the production of large amounts of secondary metabolites can alter the results. Belgian lambic beer contains a high level of volatile acids and this is taken into account in the Belgian method for determining the original extract.

In the EBC and ASBC methods for determining the original extracts of beers, the apparent extract (E % w/w) is determined from the specific gravity of the filtered beer, the alcohol content (A % w/w) from the specific gravity of the distillate, and the real extract (E_R % w/w) is determined from the specific gravity of the distillation residue made up to the original volume. From Balling's equation when the extract in the original wort (% w/w) (= °Plato) = p

$$p = 100 \left(\frac{2.0665 A + E_R}{100 + 1.0665 A} \right)$$

or

$$p = \frac{E_R + E}{q} + E_R$$

where q is the correcting factor. The ASBC also define:

$$\text{Real degree of fermentation} = \frac{100(p - E_R)}{p}$$

$$\text{Apparent degree of fermentation} = \frac{100(p - E)}{p}$$

For small breweries without laboratory facilities HM Customs and Excise (1997) provide an approximate formula to determine alcohol by volume:

$$\% \text{ABV} = (\text{OG} - \text{PG}) \times f$$

where OG is the original gravity of the wort, PG is the present gravity of the beer, and f is a factor connecting change in gravity with alcoholic strength. Unfortunately f is not constant and varies from 0.125 for weak beers to 0.135 for very strong beers. For the majority of popular UK beers f is 0.128–0.129. Brewers using this method should obtain confirmatory testing by an independent analyst at least annually.

19.1.3 Carbohydrates

The total carbohydrates remaining in beer can be estimated spectrophotometrically with anthrone in 85% sulphuric acid (*Analytica-EBC*, ASBC, IoB) for a range of beers values between 0.89–5.98% as glucose were found. Fully attenuated low carbohydrate ‘lite’ beers, originally brewed for diabetic patients, are now generally available with carbohydrate contents of 0.4–0.9% w/v as glucose. Of the carbohydrates present in wort, glucose (4.1), fructose (4.2), sucrose (4.3), maltose (4.4) and maltotriose (4.5) will usually be fermented. Under-attenuating yeast strains will not ferment maltotriose while super-attenuating strains will partly ferment maltotetraose (4.6) but, in general, beers will contain only low levels of fermentable sugars other than those added as primings (Table 19.5). Nevertheless trace amounts of many other sugars have been detected in beer including the monosaccharides; D-ribose (4.12), L-arabinose (4.11), D-xylose (4.10), D-mannose (4.8) and D-galactose (4.9), the disaccharides isomaltose (4.13), cellobiose (4.18) and kojibiose, and the trisaccharides panose (4.14) and isopanose (4.15). Data for these and other oligosaccharides are given in Table 19.6.

Analytica-EBC and ASBC give methods for the fermentable carbohydrates in beer by HPLC. A detailed study of the dextrans in Tuborg lager beer was made using gel chromatography (Enevoldsen and Schmidt, 1974). The carbohydrates present were resolved into the following fractions (degree of polymerization-glucose units and percentage of the total carbohydrates): DP 1–3, 7.4%; DP 4, 13.1%; Group I (DP 5–10), 22.7%; Group II (DP 11–16), 16.7%; Group III (DP 17–21), 9.7%; Group IV (DP 22–27), 6.2%; Group V (DP 28–34), 4.0%; and higher dextrans (DP > 35), 15.2%. Debranching studies with pullulanase indicated that the dextrans in Group I were either linear or single branched, while those in Groups II, III and IV contain two, three and four α -(1–6)-linkages respectively. The majority of the α -(1–6)-linkages in amylopectin appear to survive the brewing process.

If β -(1–3)(1–4)-D-glucan, which makes up 70% of the barley endosperm cell wall (Section 4.4.3), is not completely broken down during malting, it may survive into beer where it can precipitate and lead to filtration problems. Only β -glucans with molecular weights in excess of 200,000 daltons are said to precipitate. Two methods of analysis for β -glucans are given in *Analytica-EBC*, one enzymatic using lichenase and the other using the fluorochrome Calcofluor. A range of beers contained 0–650 mg/l of β -glucan; 10/36 had no β -glucan but a beer which precipitated a β -glucan gel contained 1,900 mg/l. By colorimetric methods beers were found to contain 0.13–0.21 % of fructose and fructosans and 0.25–0.39 % of pentosans. Schwarz and Han (1995) found the arabinoxylan content of a number of beers was in the range of 514–4,211 mg/l.

Table 19.5 Sugar content of commercial beers shown as percentage (w/v) in sample (Otter and Taylor, 1967)

Type of beer	OG	SG	Fructose	Glucose	Sucrose	Maltose (hydrate)	Maltotriose	Maltotetraose	Total
1 Pale ale	1050	1011	Nil	0.06	Nil	0.54	0.28	0.04	0.92
2 Brown ale (primed)	1032	1012	1.0	1.0	Trace	Trace	0.2	0.4	2.6
3 Stout (primed)	1033	1013	0.53	0.61	Trace	Trace	0.08	0.06	1.28
4 Sweet stout (primed)	1045	1022	0.6	1.2	Trace	Trace	0.6	0.3	3.6*
5 Pale ale	1068	1019	0.01	0.01	Nil	0.7	1.7	0.4	2.9
6 Strong ale	1085	1026	Trace	Trace	Nil	0.16	0.21	0.12	0.49
7 Lager	1032	1007	Nil	Nil	Trace	Trace	Trace	Trace	Trace
8 Lager (export)	1045	1008	Nil	Trace	Nil	Trace	0.28	0.18	0.46
9 Stout (conditioned)	1044	1008	Nil	Nil	Nil	Nil	Trace	Nil	Trace
10 Ale	1038	1002	Trace	0.8	Nil	Nil	Trace	Trace	0.8
11 Lager	1040	1003	0.18	0.49	Nil	Nil	Nil	Nil	0.67
12 Lager	1046	1003	Nil	Trace	Nil	Trace	Trace	Trace	Trace
13 Lager	1045	1004	Nil	0.27	Nil	0.17	0.24	0.09	0.77
14 Lager	1052	1011	Trace	0.15	Nil	0.13	0.16	0.14	0.58
15 Lager	1045	1008	Nil	Nil	Nil	0.25	0.33	0.20	0.78

* Contained also lactose (hydrate) 0.9%

Table 19.6 Oligosaccharides in beer (g/100 ml as glucose)

	Lager (Danish)*	Lager (German)†	Diabetic lager†
Pentose	–	0.019	0.052
Fructose	} 0.02	0.015	–
Glucose		–	0.008
Isomaltose	0.08	0.102	0.098
Maltose	0.07	0.188	0.143
Panose	–	0.036	0.066
Maltotriose	0.17	0.315	0.193
4- α -Isomaltosyl-D-maltose	–	0.049	0.100
Maltotetraose	0.30	0.187	0.043
Maltopentaose	0.08	0.144	0.100
Maltohexaose	0.15	0.130	0.039
Maltoheptaose	0.15	0.063	0.035
Malto-octaose	0.17	} 1.560	} 0.065
Maltonoaoase	0.15		
Higher dextrins	1.06	–	–
Total	2.40	2.830	0.092

* Gjertsen (1955).

† Silbereisen and Bielig (1961).

19.1.4 Other constituents containing carbon, hydrogen and oxygen

Non-volatile

Many of these components are products of yeast metabolism. Most of the intermediates in the metabolic pathways discussed in Chapter 12 have been detected in beer. Quantitatively glycerol is important and a range of 436–3,971 mg/l has been found; the highest level in a special beer of OE 27.3 g/100 ml. In general, top fermented beers had higher glycerol levels than Pilsen-type beers (Klopper *et al.*, 1986). Significant amounts of higher polyols have not been found but beer contains butane-2, 3-diol (up to 280 mg/l) and smaller amounts of pentane-2, 3-diol together with 3-hydroxybutan-2-one (9.16, acetoin, 3–26 mg/l) and 3-hydroxypentan-2-one. These are reduction products of the volatile vicinal diketones (see later). Peppard and Halsey (1982) found 2, 4, 5-trimethyl-1, 3-dioxolane (19.1) in beer (c. 0.1 mg/l); this is the cyclic acetal formed between butane-2, 3-diol and ethanal (acetaldehyde). Similar 1, 3-dioxolanes formed between butane-2, 3-diol and isobutanal and isopentanal were also detected. Another non-volatile alcohol found in beer is tyrosol (19.2), the Ehrlich pathway degradation product of tyrosine. Canadian lager had 22.1–29.4 mg/l while ales had 3.0–13.6 mg/l, well below the taste threshold of 200 ppm (McFarlane and Thompson, 1964).

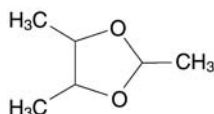

(19.1) 2,4,5-Trimethyl-1,3-dioxolane

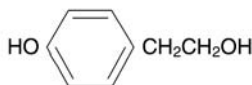

(19.2) tyrosol

Non-volatile acids found in beer are listed in Table 19.7. In addition, Klopper *et al.* (1986) found pyruvic acid (1–127 mg/l), malic acid (6–136 mg/l), lactic acid (10–1362 mg/l) and citric acid (6–211 mg/l) in a range of beers; the highest levels of lactic acid (and acetic acid) were found in Belgian ‘acid’ beers. The level of oxalic acid in beers

is important because the insoluble calcium salt may cause a haze and/or promote gushing.

Beers contain trace amount of lipids. A Swedish beer (12 °Plato) was found to contain (mg/l): triglycerides, 0.1–0.2; diglycerides, 0.1; monoglycerides, 0.1–0.3; sterol esters, 0.01; free sterols, 0.01–0.02 and free fatty acids C₄–C₁₀, 10–15; and C₁₂–C₁₈, 0–0.5 (Äyräpää *et al.*, 1961). Similar data were found for other beers. The free fatty acids are volatile but the addition of another substituent usually results in loss of volatility. Autoxidation of linoleic acid gives rise to isomers of dihydroxy- and trihydroxyoctadecenoic acids. The concentration of these acids (Table 19.7) is greater than that of linoleic acid itself. These hydroxy acids are potential precursors of 2-*trans*-nonenal, which contributes a cardboard flavour to stale beer. The influence of lipids on foam and head retention is discussed later.

Also included in Table 19.7 are the phenolic acids present in beer which, with other polyphenols, are extracted from malt and hops (Sections 4.8 and 8.4). Polyphenols give colours with ferric salts and *Analytica-EBC* and the ASBC give a non-specific spectrophotometric method for polyphenols based on the colour formed at 600 nm with ferric ammonium citrate. (+)-Catechin (**4.138**) can be used as standard. In addition *Analytica-EBC* give a spectrophotometric method for flavanoids based on the colour formed with *p*-dimethylaminocinnamaldehyde: again (+)-catechin may be used as standard. By HPLC the polyphenols quercetin (**8.58**, R = H) (36–148 ppm), rutin (**8.58**, R = β -L-rhamnosyl-6- β -D-glucosyl) (1.5–7.7 ppm), catechin (26–141 ppm) and epicatechin (**4.139**) (8.5–127 ppm) have been quantified in beer (Qureshi *et al.*, 1979).

Beers also contain proanthocyanidins (anthocyanogens) of which the dimeric procyanidin B-3 (**4.143**) predominates (0.5–4.0 ppm). Whittle *et al.* (1999) examined the polyphenols in sixty beers by HPLC with electrochemical detection. They found over twenty procyanidin dimers and trimers in beer but no tetramers or pentamers although these were present in barley extracts. They also observed which peaks were removed when the beer was treated with excess polyvinylpyrrolidone (20 g/l). As the name implies, proanthocyanidins on treatment with acid form the coloured anthocyanidin pigments (λ_{\max} c. 545 nm) but the reaction is not straightforward and the yield of pigment from different products varies. Polyphenols, particularly proanthocyanidins, react with proteins during the storage of beer to produce non-biological haze (see later) but the yields of anthocyanidins, liberated with acid, do not correlate with the shelf-life of the beer. The haze potential of beers has been estimated nephelometrically by the haze formed after treatment with either cinchonidine sulphate, polyvinylpyrrolidone 700 or tannic acid.

Closely related to the polyphenols are the hop resins discussed in Chapter 8. The major bittering principles in beer are the *cis*- and *trans*-isomers of isochumulone, isohumulone and isoadhumulone (**8.40**). The individual isomers may be resolved by HPLC but for routine analysis they are usually estimated together from the light absorption of an iso-octane extract of acidified beer at 275 nm (*Analytica-EBC*, IoB and ASBC). To avoid making assumptions about the nature of the bittering principles, the absorbance is multiplied by 50 and the result given as (International) Bitterness Units (IBU or BU). Nevertheless, in beers brewed with fresh hops IBU approximate to mg iso- α -acids/l. Beers may contain 10–60 IBU (Tables 19.1 and 19.2) and exceptionally 100 IBU (Glaser, 2002). The sensory detection threshold of the iso- α -acids is c. 5–6 mg/l and the tetrahydro- and hexahydroiso- α -acids are even more bitter (Weiss *et al.*, 2002).

Volatile

Although trace amounts of the volatile constituents of malt and hops may survive wort boiling, the majority of the volatile constituents of beer are fermentation products. After

Table 19.7 Non-volatile acids in beer

Acid (ppm)	Berlin Pilsner (<i>a</i>)	German (<i>b</i>)	British (<i>c</i>)	American (<i>d</i>)	Flavour threshold (<i>e</i>)
C ₂ Glycolic	—	—	—	—	
Oxalic (4.151)	—	9.9–22.8	—	0.5–3.0	
C ₃ D-Lactic	—	20–200	—	—	
L-Lactic	—	40–152	—	—	
Lactic (4.150)	188	—	44–292	—	(400)
Pyruvic (4.146)	—	42–75	10–104	—	(300)
Malonic	0.02	—	—	—	
C ₄ Succinic (4.149)	48	—	36–166	—	
Fumaric (4.148)	—	—	—	—	
Malic (4.152)	—	55–105	14–97	—	
Oxaloacetic	—	—	—	—	(500)
Tartaric	—	—	—	—	(600)
C ₅ 2-Hydroxy-3-methylbutyric	0.26	—	—	—	
Levulinic	—	—	—	—	
2-Methylfumaric (Mesaconic)	—	—	—	—	
Glutaric	0.01	—	—	—	
2-Hydroxyglutaric	—	—	0–17	—	
Citramalic	—	—	—	(5.9–15.2)	
2-Oxoglutaric (4.147)	—	—	0–20	—	
C ₆ 2-Hydroxy-3-methylpentanoic	0.29	—	—	—	
2-Hydroxy-4-methylpentanoic	0.33	—	—	—	
Adipic	—	—	—	—	
Kojic	—	—	—	5–78.2	
Citric (4.153)	—	130–230	56–158	—	
Isocitric	—	—	—	—	
Oxalosuccinic	—	—	—	—	
C ₇ Benzoic	0.45	—	—	—	
2-Hydroxybenzoic	0.02	—	—	1.00–9.0	
4-Hydroxybenzoic	0.13	—	—	—	
2-Hydroxyheptanoic	0.06	—	—	—	
3,4-Dihydroxybenzoic	2.4	—	—	6.3–29.0	
2,5-Dihydroxybenzoic (Gentisic)	—	—	—	2.8–12.7	

Pimelic	0.01	–	–	–	
Gallic (4.125)	–	–	–	12.0–30	360
C ₈ Phenylacetic	0.93	–	–	–	2.5
2-Hydroxyoctanoic	0.04	–	–	–	
3-Hydroxyoctanoic	0.07	–	–	–	
2-Ethylhexanoic	–	–	–	10.2	11–32
4-Hydroxyphenylacetic	0.04	–	–	–	
Suberic	0.15	–	–	–	
Vanillic	2.4	–	–	0.3–1.5	80
Phthalic	0.02	–	–	–	
C ₉ Phenylpropionic	0.01	–	–	–	
<i>trans</i> -Cinnamic	0.5	–	–	1.0–8.3	
<i>cis</i> -Cinnamic	< 0.01	–	–	(<i>trans</i> + <i>cis</i>)	
Phenyl-lactic	1.2	–	–	–	
4-Hydroxyphenylpropionic	0.02	–	–	–	
<i>trans-p</i> -Coumaric	1.9	–	–	8.21	520
<i>cis-p</i> -Coumaric	0.02	–	–	(<i>trans</i> + <i>cis</i>)	
Caffeic	–	–	–	1.4–8.0	690
Azeleic	1.5	–	–	–	
C ₁₀ 3-Hydroxydecanoic	0.16	–	–	–	
<i>trans</i> -Ferulic	4.6	–	–	1.7–20.8	660
<i>cis</i> -Ferulic	1.1	–	–	(<i>trans</i> + <i>cis</i>)	
C ₁₁ Undecanedioic	0.13	–	–	–	
Sinapic	–	–	–	0.7–3.6	
C ₁₂ Dodecanedioic	0.18	–	–	–	
C ₁₆ Chlorogenic	–	–	–	1–11.2	
C ₁₈ Trihydroxyoctadecanoic					
9,12,13-10- <i>trans</i>	–	4.9–9.0	–	–	
9,12,13-11- <i>trans</i>	–	1.0–2.4	–	–	
9,10,11-12- <i>trans</i>	–	0.4–0.7	–	–	

[a] Tressl *et al.* (1975)

[b] Mandl and Piendl (1971)

[c] Coote and Kirsop (1974)

[d] Qureshi *et al.* (1979)

[e] Meilgaard (1975)

Table 19.8 Volatile constituents of beer(a) Alcohols [*a*]

	Concentration (ppm) [<i>b</i>]	Flavour threshold (ppm) [<i>c</i>]
C ₁ Methanol	–	10,000
C ₂ Ethanol	–	14,000
C ₃ Propanol	–	800
Propan-2-ol	–	1,500
C ₄ Butanol	–	450
Butan-2-ol	–	16
2-Methylpropanol	4.8	200
C ₅ Pentanol	0.15	(80)
Pentan-2-ol	–	45
2-Methylbutanol	84.0	70
3-Methylbutanol	(2 Me + 3 Me)	65
Furfuryl alcohol	1.20	3,000
C ₆ Hexanol	0.33	4.0
Hexan-2-ol	–	4.0
Hex-2-enol	0.025	13
Hex-3-enol	0.020	15
C ₇ Heptanol	–	1.0
Heptan-2-ol	0.015	0.25
Benzyl alcohol	–	900
C ₈ Octanol	–	0.9
Octan-2-ol	0.005	0.04
Oct-1-en-3-ol	0.030	0.2
2-Phenylethanol	1.8	125
Tyrosol	see text	200
4-Vinylphenol	0.025	–
C ₉ Nonanol	–	0.08
Nonan-2-ol	0.01	0.075
4-Vinylguaiacol	0.10	0.3
C ₁₀ Decanol	–	0.18
Decan-2-ol	0.005	0.015
Linalol	–	0.08
α-Terpinol	–	2.0
Nerol	–	0.50
C ₁₂ Dodecanol	–	0.40
Dodecan-2-ol	–	–

(b) Aldehydes [*a*]

	Concentration (ppm) [<i>d</i>]	Flavour threshold (ppm) [<i>c</i>]
C ₂ Acetaldehyde	See Table 19.10	10
Glyoxal	–	–
C ₃ Propanal	–	30
Prop-2-enal (acrolein)	1.6	15
Pyruvaldehyde	–	–
C ₄ Butanal	10.9	(1.0)
2-Methylpropanal	–	(1.0)
But-2-enal (crotonal)	1.33	8

Table 19.8 Continued

	Concentration (ppm) [d]	Flavour threshold (ppm) [c]
C ₅	Pentanal	2.7
	2-Methylbutanal	–
	3-Methylbutanal	7.0
	Pent-2-enal	0.59
	Furfural	(25.0)
C ₆	Hexanal	1.6
	Hex-2-enal	0.36
	5-Hydroxymethylfurfural	see text
C ₇	Heptanal	1.2
	Hept-2-enal	0.08
	Benzaldehyde	10
C ₈	Octanal	1.4
	Oct-2-enal	0.03
	2-Phenylacetaldehyde	(5)
C ₉	Nonanal	3.7
	Non-2-enal	0.07
C ₁₀	Decanal	0.9
	Dec-2-enal	trace
C ₁₁	Undecanal	0.4
C ₁₂	Dodecanal	0.2

(c) Acids [a]

	Concentration (ppm) [e]	Flavour threshold (ppm) [c]
C ₁	Formic	–
C ₂	Acetic	175
C ₃	Propionic	150
C ₄	Butyric	0.62
	2-Methylpropionic	1.1
	Crotonic	–
C ₅	Pentanoic (Valeric)	0.03
	2-Methylbutyric	–
	3-Methylbutyric	1.3
	Pentenoic	–
C ₆	Hexanoic (Caproic)	2.5
	Hex-2-enoic	} 0.01
	Hex-3-enoic	
	4-Methylpent-3-enoic	0.32
	3-Carboxypropionic	0.22
C ₇	Heptanoic (Oenanthalic)	0.03
	Hept-2-enoic	< 0.01
	4-Methylhex-2-enoic	–
	Benzoic	0.45
C ₈	Octanoic (Caprylic)	6.1
	6-Methylheptanoic	–
	Oct-2-enoic	< 0.01
	Phenylacetic	0.93

Table 19.8 Continued

	Concentration (ppm) [e]	Flavour threshold (ppm) [c]
C ₉ Nonanoic (Pelargonic)	0.02	
Non-2-enoc	< 0.01	17
Phenylpropionic	0.01	–
Phenyllactic	1.2	–
<i>trans</i> -Cinnamic	0.50	–
<i>cis</i> -Cinnamic	< 0.01	–
C ₁₀ Decanoic (Capric)	0.7	10
Dec-4-enoic	0.23	–
Dec-4,8-dienoic	0.03	–
Geranic	–	–
C ₁₁ Undecanoic	< 0.01	–
C ₁₂ Dodecanoic (Lauric)	0.11	6.1
Dodecenoic	0.01	–
C ₁₃ Tridecanoic	< 0.01	–
C ₁₄ Tetradecanoic (Myristic)	0.02	–
Tetradecenoic	–	–
C ₁₅ Pentadecanoic	< 0.01	–
C ₁₆ Hexadecanoic (Palmitic)	0.05	–
Hexadec-9-enoic (Palmitoleic)	0.02	–
C ₁₇ Heptadecanoic	< 0.01	–
C ₁₈ Octadecanoic (Stearic)	0.02	–
Octadec-9-enoic (Oleic)	0.02	–
Octadeca-9, 12-dienoic (Linoleic)	0.01	–
Octadeca-9, 12, 15-trienoic (Linolenic)	< 0.01	–

(d) Esters [a]

	Concentration (ppm) [b]	Flavour threshold (ppm) [c]
C ₃ Ethyl formate	–	(150)
Methyl acetate	–	550
C ₄ Ethyl acetate	see Table 19.9	33
C ₅ Ethyl propionate	0.08	–
Propyl acetate	–	30
Methionol acetate	0.025	–
C ₆ Ethyl butyrate	–	0.4
Ethyl 2-methylpropionate	0.48	5.0
Butyl acetate	–	7.5
But-2-yl acetate	–	12
2-Methylpropyl acetate	–	1.6
2-Methylbutyl formate	–	5.0
C ₇ Methyl hexanoate	–	–
Ethyl-3-methylbutyrate	–	1.3
Amyl acetate	–	–
3-Methylbutyl acetate	6.3	1.6
Methyl hexanoate	–	–
Furfuryl acetate	0.060	–

Table 19.8 Continued

	Concentration (ppm) [b]	Flavour threshold (ppm) [c]
C ₈	Methyl heptenoate	–
	Ethyl hexanoate	0.95
	3-Methylbutyl propionate	0.15
	Hexyl acetate	0.025
	Methyl 4-methylhex-2-enoate	0.06
	Ethyl hexenoate	–
	Ethyl nicotinate	1.4
C ₉	Methyl octanoate	–
	Ethyl heptanoate	–
	Amyl butyrate	–
	3-Methylbutyl butyrate	–
	3-Methylbutyl 2-methylpropionate	0.140
	Heptyl acetate	0.025
	Ethyl heptenoate	–
	Ethyl benzoate	0.01
C ₁₀	Ethyl octanoate	1.50
	Butyl hexanoate	–
	2-Methylpropyl hexanoate	0.025
	Amyl 3-methylbutyrate	–
	3-Methylbutyl 3-methylbutyrate	0.040
	Hexyl butyrate	–
	Octyl acetate	0.030
	2-Phenylethyl acetate	1.625
C ₁₁	Ethyl nonanoate	–
	Amyl hexanoate	–
	Pent-2-yl hexanoate	–
	3-Methylbutyl hexanoate	0.420
	Heptan-2-yl butyrate	–
	Nonyl acetate	0.005
	Ethyl nonenoate	0.045
	2-Phenylethyl propionate	0.010
Ethyl cinnamate	0.005	
C ₁₂	Ethyl decanoate	0.190
	Butyl octanoate	–
	3-Methylbutyl heptanoate	0.020
	Hexyl hexanoate	–
	Octyl butyrate	–
	2-Phenylethyl butyrate	–
	3-Phenylethyl 2-methylpropionate	0.015
	3-Methylbutyl benzoate	–
	Ethyl dec-4-enoate	0.035
	Ethyl deca-4, 8-dienoate	0.015
C ₁₃	2-Methylbutyl octanoate	0.015
	3-Methylbutyl octanoate	0.830
	2-Phenylethyl 3-methylbutyrate	0.015
C ₁₄	Ethyl dodecanoate	0.030
	3-Methylbutyl nonanoate	–
	Hexyl octanoate	–
	Octyl hexanoate	–
	2-Phenylethyl hexanoate	0.075
	2-Phenylethyl hexenoate	–

Table 19.8 Continued

	Concentration (ppm) [b]	Flavour threshold (ppm) [c]
C ₁₅	2-Methylbutyl decanoate	0.005
	3-Methylbutyl decanoate	0.095
	3-Methylbutyl dec-4-enoate	0.020
C ₁₆	Ethyl tetradecanoate	–
	Hexyl decanoate	–
	2-Phenylethyl octanoate	0.015
C ₁₇	3-Methylbutyl dodecanoate	0.010

(e) Lactones [a]

	Concentration (ppm) [b]	Flavour threshold (ppm) [c]
C ₄	4-Butanolide	–
C ₆	4-Hexanolide	0.0200
	4,4-Dimethylbutan-4-olide	0.160
	4,4-Dimethylbut-2-en-4-olide	1.750
C ₇	4-Heptanolide	0.015
C ₈	4-Octanolide	0.020
C ₉	4-Nonanolide	0.320
C ₁₀	4-Decanolide	0.020
C ₁₁	4-Dihydroactindiolide	0.030

(f) Ketones [a]

	Concentration (ppm) [b]	Flavour threshold (ppm) [c]
C ₄	Butan-2-one	(80)
	Butane-2,3-dione	0.15
	3-Hydroxybutan-2-one	(50)
C ₅	Pentan-2-one	(30)
	Pentan-3-one	(30)
	Pentane-2,3-dione	0.9
	3-Hydroxypentan-2-one	–
	2-Methyltetrahydrofuran-3-one	0.025
	2-Methyltetrahydro-thiophen-3-one	0.005
C ₆	Hexan-2-one	–
	3-Methylpentan-2-one	0.060
	4-Methylpentan-2-one	0.12
	2-Acetylfuran	0.040
C ₇	Heptan-2-one	0.110
C ₈	Octan-2-one	0.010
	6-Methylhept-5-en-2-one	0.050
C ₉	Nonan-2-one	0.030
C ₁₀	Decan-2-one	–
C ₁₁	Undecan-2-one	0.001

Table 19.8 Continued

(g) Hydrocarbons [a]

	Concentration (ppm) [b]	Flavour threshold (ppm) [c]
C ₆ Cyclohexane	–	–
C ₇ 3,4-Dimethylpent-2-ene	–	–
Toluene	–	–
C ₈ 2,2-Dimethylhexane	–	–
<i>o</i> -Xylene	0.020	–
Styrene	0.070	–
C ₉ Methylethylbenzene	0.020	–
C ₁₀ <i>i</i> -Butylbenzene	–	–
α -Pinene	–	–
Limonene	–	–
Myrcene	–	0.013
Naphthalene	0.015	–
C ₁₅ Carophyllene	–	–

[a] Drawert and Tressl (1972)

[b] Tressl *et al.* (1978)

[c] Meilgaard (1975)

[d] Greenhoff and Wheeler (1981)

[e] Tressl *et al.* (1975)

ethanol, discussed above, the largest group of volatile constituents are the higher alcohols; those identified in beer are listed in Table 19.8(a) By distillation the higher alcohol fraction may be separated when it is known as fusel oil. Thus, the distiller has a closer control over the higher alcohol content of his beverage than the brewer. Gin, vodka and grain whisky have low levels of higher alcohols while malt whisky and brandy, produced in pot stills, usually have higher levels of these congeners.

The principal higher alcohols found in beer are 3-methylbutanol (isoamyl alcohol), 2-methylbutanol (*active*-amyl alcohol), 2-methylpropanol (isobutyl alcohol), propanol, (propyl alcohol) and β -phenylethanol (phenethyl alcohol) (Table 19.9). Greenshields (1974) found that the level of higher alcohols in home-brewed beers and wines was ten times higher than the level in commercial products. The major volatile constituents of beer are most conveniently examined by gas chromatography. The results given in Table 19.9 (Morgan, 1965) were obtained by GC after distillation and extraction of the volatile products into ether. Direct injection of beer on to a suitable GC column minimizes sample preparation but requires frequent replacement of the top layer of a packed column or of the glass wool in the injection port due to the deposition of beer solids. Although the precision is not high (Baker, 1989) a headspace method of analysis of the major volatiles in beer has been approved giving values for acetaldehyde, propanol, isobutanol, methylbutanols, ethyl acetate and ethyl hexanoate (Fig. 19.1).

In order to identify the minor volatile constituents of beer it is usually necessary to examine a distillate or solvent extract which can be fractionated further by adsorption chromatography (Tressl *et al.*, 1975, 1978, Lermusieau *et al.*, 2001).

Also included in Table 19.8(a) are 4-vinylphenol and 4-vinylguaicol (**4.134**, 4-hydroxy-3-methoxystyrene), which are regarded as off-flavours in most beers. However,

Table 19.9 Principal volatile constituents of beer (Morgan, 1965)

Ethanol (% v/v)	B.p. (°C)	Concentration Range			
		Stout	Pale ale	Brown ale	Lager
	78	2.0–8.9	3.4–4.0 (mg/l)	2.1–4.5	2.8–3.2
<i>n</i> -Propanol	97	13–60	31–48	17–29	5–10
2-Methylpropanol	108	11–98	18–33	11–33	6–11
2-Methylbutanol	128	9–41	14–19	8–22	8–16
3-Methylbutanol	131	33–169	47–61	28–77	32–57
β -Phenylethanol	220	20–55	36–53	19–44	25–32
Ethyl acetate	77	11–69	14–23	9–18	8–14
Isoamyl acetate	139	1.0–4.9	1.4–3.3	0.4–2.6	1.5–2.0

4-vinylguaicol, which has a clove-like, spice-like flavour, provides part of the essential character of Weizenbier and Rauchbier. A range of ale and lagers contained 0–0.09 mg/l 4-vinylguaicol, below the threshold value of 0.3 mg/l, but Weissbier contains 0.8–1.5 mg/l (McMurrough *et al.*, 1996). These phenols are formed by decarboxylation of *trans-p*-coumaric acid (**4.129**) and *trans*-ferulic acid (**4.131**) respectively. This may occur thermally during kilning or wort boiling or enzymatically during fermentation. The capacity of yeasts to decarboxylate cinnamic acids (Pof+ phenotype) is strong in wild strains of *Saccharomyces* but absent from lager-brewing yeasts and most ale-brewing yeasts. However, it is present in the yeasts used in the production of wheat beers. The level of 4-vinylguaicol in beer declines during storage (with a half life of c. 60 days at 18 °C) presumably due to the formation of 4-(1-ethoxyethyl)guaicol. Decarboxylation of cinnamic acid will give styrene (Table 19.8(g)), which is reported to be carcinogenic. Accordingly Pof+ strains of yeast are avoided in brewing most beers.

Only low levels of aldehydes are found in beer (Table 19.8(b)). As discussed in Chapter 12, ethanol and the higher alcohols are formed by reduction of the corresponding aldehydes by the enzyme alcohol dehydrogenase. Acetaldehyde (ethanal) is the major aldehyde in beer and some values are given in Table 19.10. Acetal (1, 1-diethoxyethane),

**Fig. 19.1** Typical chromatogram of volatile compounds in beer (Institute of Brewing, Methods of Analysis, 1997)

Table 19.10 Acetaldehyde content of beers (Otter and Taylor, 1971)

Beer	Acetaldehyde content (ppm) (mean value in parentheses)
British lager	2.3–28.2 (8.7)
Foreign lager	0–13 (5.4)
Light and pale ales	3.8–33.8 (8.2)
Primed beers	3.0–37.2 (15.2)
Irish stout	0.5–10.0 (4.0)
American beers	2–18 (9.1)

formed by condensation of ethanal with two molecules of ethanol, has been detected in beer. During the storage of bottled beer higher alcohols are oxidized to aldehydes by melanoidins; these aldehydes have much lower threshold values than the parent alcohols and can produce off-flavours. As mentioned above, the cardboard flavour of stale beer is thought to be due to 2-*trans*-nonenal and 5-methylfurfural (9.22). Among the heterocyclic compounds formed during wort boiling (Chapter 9), 5-hydroxymethylfurfural (9.8, R = CH₂OH), 5-methylfurfural and furfural (9.17) itself are found in beer. One survey of over 300 German beers reported 0.5–4 ppm of 5-hydroxymethylfurfural (maximum value 7.8 ppm) (Thalacker and Kaltwasser, 1978) but other workers found higher levels increasing with beer colour; one dark German beer contained 71.5 ppm (Kieninger and Birkova, 1975). Lower levels of furfural are found (< 15 µg/l) but these increase markedly during pasteurization and storage at 40 °C; the maximum level of furfural reported was 1,843 µg/l (Bernstein and Laufer, 1977). Shimizu *et al.* (2001) have investigated factors affecting the formation of 5-hydroxymethylfurfural and stale flavours in beers.

Normally during fermentation acetaldehyde is reduced to ethanol but it can be oxidized to acetic (ethanoic) acid, which is the major volatile acid in beer. The ASBC describe two methods for estimating the total acidity of beer, one by potentiometric titration, the other using phenolphthalein as indicator. *Analytica-EBC* give enzymatic methods for acetic and lactic acids. Lager beers were found to contain 57–145 mg/l acetic acid. Belgian lambic and gueuze beers, produced by spontaneous fermentation, contain 460–1,210 ppm acetic acid and 1,890–3,434 ppm lactic acid (Van Oevelen *et al.*, 1976). Other volatile acids detected in beer are listed in Table 19.8(c). As would be expected from their mode of biosynthesis (Chapter 12), fatty acids with an even number of carbon atoms predominate.

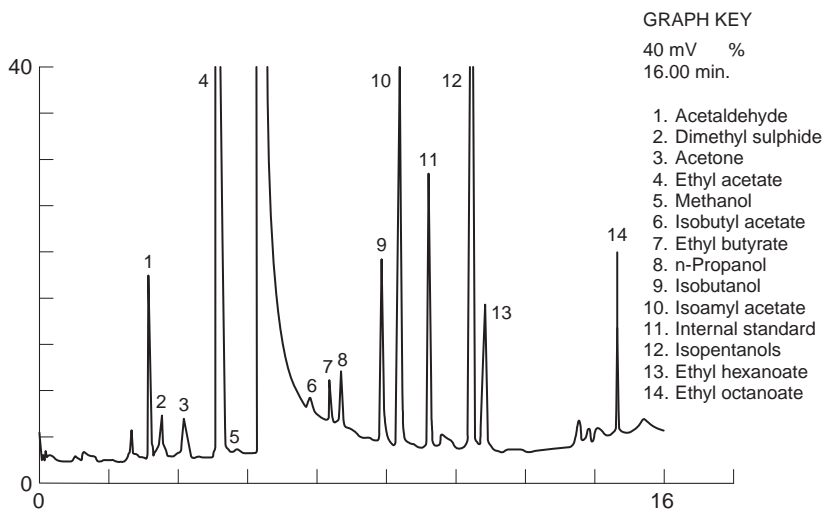
Each of the alcohols listed in Table 19.8(a) is theoretically capable of esterifying each of the acids listed in Tables 19.7 and 19.8(c) potentially giving almost 4,000 esters in beer; those which have been identified are given in Table 19.8(d). Ethyl acetate is the major ester found and some concentrations in a range of beers is given in Table 19.9. The concentrations found exceed those expected from the equilibrium constant ($K = 4$) of the reaction:

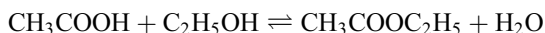

showing that esters are biosynthesized during fermentation (Chapter 12). Of the other esters found in beer the ethyl esters predominate but the acetates of the higher alcohols (the so-called ‘banana esters’) are also important (Table 19.9). The esters undoubtedly contribute to the overall flavour of beer and abnormally high levels may be regarded as off-flavours. The wild yeasts *Hansenula* and *Pichia* produce large quantities of ethyl acetate by aerobic fermentation. Lambic and gueuze beers contain 33.4–167.0 ppm of

ethyl acetate and 107–483 ppm of ethyl lactate (Van Oevelen *et al.*, 1976). The majority of the esters in beer are fermentation products but traces of esters from hop oil may be present. Methyl 4-decenoate and methyl 4,8-decadienoate, present in hop oil, are transesterified during fermentation to give the corresponding ethyl esters in beer. No doubt other esters in wort are transesterified during fermentation to give ethyl esters in beer. Lactones (Table 19.8(e)) are cyclic esters of hydroxyacids. Dihydro-2(3*H*)-furanone (19.3) and dihydro-5-methyl-2(3*H*)-furanone may be regarded as lactones.

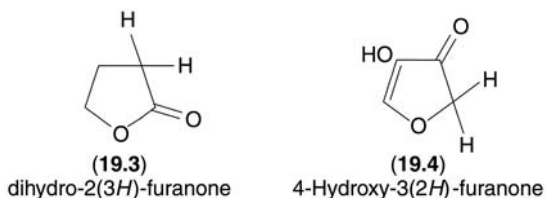

Ketones (Table 19.8(f)) are, like aldehydes, carbonyl compounds but they are not major fermentation products. Many of those present in beer may be derived from hop oil or hop resin degradation products. An exception may be 2-acetylfuran which occurs at higher levels in ales (90–97 ppm) than in lagers (4–12 ppm). 4-Hydroxy-3(2*H*)-furanone (19.4) derivatives also contribute to beer flavour. 5-Methyl-4-hydroxy-3(2*H*)-furanone has a meaty and brothy flavour note but the level in beer (0.12–0.77 ppm) is less than the flavour threshold (8.3 ppm). 2,5-Dimethyl-4-hydroxy-3(2*H*)-furanone has a sweet caramel flavour (threshold 0.16 ppm) so the concentration in beer (0.19–2.73 ppm) will cause it to influence flavour. 2-(or 5)-Ethyl-5-(or 2)-methyl-4-hydroxy-3(2*H*)-furanone also has a sweet caramel flavour with a lower threshold (0.02 ppm) than the dimethyl compound. It has been detected in some beers but not in others; in all cases the concentration was less than the threshold level (Mackie and Slaughter, 2000).

Vicinal or α -diketones have two carbonyl groups on adjacent carbon atoms. The most important vicinal diketone (VDK) in beer is diacetyl (9.14, butane-2,3-dione) which is accompanied by smaller amounts of pentane-2,3-dione. These diketones produce butterscotch flavours with thresholds of 0.07–0.15 mg/l and 0.9 mg/l respectively. Quantities in excess of 0.15 mg/l of diacetyl are said to produce an off-flavour in lager beer but higher levels may be acceptable in ales and stouts. Many methods have been proposed for the analysis of diacetyl and vicinal diketones. The most specific involves gas liquid chromatography with an electron capture detector which is sensitive to vicinal diketones but not to the majority of other beer constituents (Harrison *et al.*, 1965a,b). The Institute of Brewing has described methods using both packed and capillary columns (Buckee and Mundy, 1994) and the latter, which uses hexane-2,3-dione as internal standard, has been accepted by the EBC. The analyses given in Table 19.11 were obtained using such methods. In addition there are several colorimetric methods for determining vicinal diketones. The vicinal diketones are by-products of the biosynthesis of the amino acids valine and leucine (Fig. 12.21). One of the intermediates, α -acetolactate, decomposes to diacetyl on heating so analytical methods which involve a preliminary distillation, especially those of fermenting wort, give high results. Headspace analysis avoids distillation and using this technique, with electron capture detection, it was found that during fermentation of an Irish stout the maximum level of vicinal diketones (0.6 ppm) was found 44 h after pitching but thereafter the level fell to about 0.1 ppm. Yeast strains differ in the amount of diacetyl they produce and the choice of yeast strain is probably the most important factor in controlling the level of VDK in beer

Table 19.11 Diacetyl and Pentane-2,3-dione content of beers (mg/l) (Harrison *et al.*, 1965a,b)

Quality*	Diacetyl	Pentane-2,3-dione
Barley wine (4)	0.11–0.40	0.04–0.08
Lager (9)	0.02–0.08	0.01–0.05
Ale (9)	0.06–0.30	0.01–0.20
Stout (5)	0.02–0.07	0.01–0.02
Stout (1)	0.58	0.26

* Number of samples in parentheses.

(Portno, 1966). In particular respiratory deficient ‘petite mutants’ of yeast produce large quantities of diacetyl and the off-flavour produced in beers infected with *Pediococci* (the so-called beer sarcina) is due to diacetyl. During fermentation ketones may be reduced to secondary alcohols. Thus reduction of diacetyl gives first 3-hydroxybutan-2-one (acetoin) and then butane-2,3-diol which are much less volatile. They are also much less potent flavouring agents with threshold values of 17 and 4,500 mg/l respectively. The addition of actively fermenting wort to beer may reduce the diacetyl content. The hop oil constituents which have been detected in beer are discussed in Chapter 8.

19.1.5 Nitrogenous constituents

Non-volatile

During the 20th century the total nitrogen content of barley, malt and beer was usually measured by the Kjeldahl method where the sample is digested with concentrated sulphuric acid and a suitable catalyst and the nitrogenous constituents are broken down to ammonium sulphate. After dilution of the digest, the ammonia is liberated and distilled into standard acid. Although the Kjeldahl method has been automated it still employs toxic and hazardous reagents and today is being replaced by the older, but now automated, Dumas combustion method (Buckee, 1994, 1995, 1997; Johnson and Johansson, 1999). Here the sample is combusted in the presence of oxygen at about 1,000 °C to give oxides of nitrogen which are catalytically reduced to nitrogen. Other products of combustion such as carbon dioxide and water are removed by selective absorption and the remaining nitrogen measured in a thermal conductivity cell. The Dumas method consistently gives slightly higher total nitrogen values than those given by the Kjeldahl method but it long been known that the Kjeldahl method does not deal efficiently with certain types of compound (Buckee, 1995). Free α -amino nitrogen is determined by an internationally agreed method measuring the purple colour formed with ninhydrin at 570 nm.

The total nitrogen content multiplied by the factor 6.25 is often expressed as ‘protein’. Most beers contain 300–1,000 mg/l total-N equivalent to 0.11–0.63% protein. An all-malt Burton strong ale contained 1,840 mg/l total-N equivalent to 1.15% protein. There appears to be no universally accepted definition of protein. Some authorities classify proteins by function, others by their molecular size. It is agreed that hydrolysis of proteins gives polypeptides, peptides and eventually amino acids (terms such as ‘proteoses and ‘proteids’ are even less well defined). One text suggests that peptides may contain up to 10 amino acid residues, polypeptides 11–100 residues and proteins more than 100 residues but Bamforth (1985) suggests that the term protein should be restricted to an undegraded molecule with an independent and unique identity such as, for example, a molecule of an enzyme. On this basis he suggested that few proteins survive into beer and most of the nitrogen is present as polypeptides. Williams *et al.* (1995) compared seven

methods for determining the protein concentration of beer including both classical and automated Kjeldahl analyses. They concluded that the protein dye-binding assays (Coomassie Brilliant Blue and Pyrogallol Red-Molybdate methods) gave reproducible values for the protein concentration consistent with the results indicated by electrophoresis.

Many new techniques have been used to study the proteins/polypeptides present in beer principally with the aim of characterizing the fractions associated with foam stability and haze formation. Dialysis with Visking tubing retains compounds with molecular weight greater than 5,000 which accounts for approximately half of the total, N. Size exclusion chromatography (gel filtration) of beer shows the presence of polypeptides across the range of molecular weights from 2,000 to > 100,000 but the majority have $M_r < 15,000$ (Dale, 1990). Sørensen and Ottesen (1978) obtained two fractions by gel filtration, one with $M_r \approx 44,000$ and the other with $M_r \approx 10,000$. The high molecular weight fraction was rich in carbohydrates and cross-reacted with yeast antibodies. Isoelectric focusing in the pH range 3.5–10 of the fraction $M_r \approx 44,000$ revealed at least 30 distinct bands. A fraction with an isoelectric point (pI) of about 4–5 had an amino acid composition resembling that of barley albumins and globulins and reacted with antibodies raised against barley soluble proteins.

Kaersgaard and Hejgaard (1979) studied methods for the purification of antigenic beer molecules and identified four antigens, the major one being derived from barley protein Z. Protein Z describes a small group of barley serpins (*serine protease inhibitors*); it has been resolved into two isoforms Z4 and Z7. Antigen 1 and barley protein Z have the same molecular weight ($M_r \approx 40$ kDa), react with the same antibody, and have almost the same amino acid composition. The exception is that Antigen 1 has a 16% lower content of lysine than protein Z and contained about 2.5% of carbohydrate, not found in protein Z. It is suggested (Hejgaard and Kaersgaard, 1983) that lysine residues in protein Z undergo Maillard-type reactions during wort boiling to give non-enzymatic glycoproteins. Danish beers contained 22–170 mg Antigen 1/l. Antigen 2 was derived from the brewery yeast.

Lipid transfer protein 1 (LTP 1, M_r 9,700) is another barley protein which survives into beer although it may undergo some denaturation during the kettle boil (Bech *et al.*, 1995). Evans and Hejgaard, (1999) studied the effects of germination and kilning on the level of protein Z4, protein Z7, and LTP 1 in beer. Other techniques used in this work include sodium dodecylsulphonate-polyacrylamide gel electrophoresis (SDS-PAGE), enzyme-linked immunosorbent assays (ELISA), and immunoblotting. The polypeptide fractions obtained can be characterized by the amino acid composition of the hydrolysate (Dale and Young, 1989b) The LTP 1 polypeptides have been studied further by Jegou *et al.* (2000). Similarly, Sheehan and Skerritt (1997) examined the beer polypeptides derived from the hordein proteins of barley which may be involved in both beer foam and chill haze formation. The hordein derived polypeptides in beer are more heterogeneous than those derived from protein Z and LTP 1. Their composition in beer is influenced by the mashing temperature and they have lower molecular weights than the barley hordeins from which they are derived.

Another protein, the enzyme proteinase A, is excreted by yeast cells into beer during fermentation and degrades foam-active proteins. Non-pasteurized commercial beers contained $0-38 \times 10^{-5}$ units/ml (one unit is the amount that hydrolyses 1 mg of insulin B chain per min at pH 6.0 and 25 °C); the higher values are found for beers with yeast cells remaining in the bottle. No Pr A activity was found in pasteurized beers (Kondo *et al.*, 1999). It should be recalled that proteinases are sometimes added to beers to break down proteins/polypeptides that may cause haze (Chapter 15). Dale and Young (1989a) have

Table 19.12 Amino acid analyses of beers (amino acids as $\mu\text{g } \alpha\text{-amino N/ml}$)

OG	Indian pale ale 1042.8	Brown ale 1031.5	Draught bitter 1040.8	Mild ale 1036	Stout 1045	Stout 1045
Alanine (4.24)	–	0.19	0.43	–	0.2	–
Ammonia	1.07	0.92	1.88	1.36	1.7	1.8
Arginine (4.28)	–	–	0.18	–	–	–
Aspartic acid (4.29)	–	0.04	0.16	0.4	0.2	0.2
Glutamic acid (4.33)	–	0.04	0.14	0.2	–	–
Glycine (4.35)	0.21	0.01	0.08	0.19	–	–
Histidine (4.36)	0.14	–	–	–	–	–
Isoleucine (4.38)	–	–	0.01	–	0.4	–
Leucine (4.39)	–	–	0.03	–	0.4	–
Lysine (4.40)	0.42	0.31	0.50	0.32	0.2	0.6
Methionine (4.41)	–	–	0.24	–	–	–
Phenylalanine (4.42)	–	0.04	0.49	0.07	–	–
Serine (4.45)	–	–	0.15	0.05	0.2	0.3
Threonine (4.46)	–	–	0.66	–	0.2	0.2
Tryptophan (4.47)	1.77	1.62	2.06	1.62	0.5	1.2
Tyrosine (4.48)	–	0.50	0.35	0.07	–	–
Valine (4.49)	–	–	0.03	–	0.4	0.7
Total $\alpha\text{-amino N}$	3.61	3.74	7.39	3.88	4.4	5.0
Proline	28.25	13.32	28.53	22.05	38.0	40.1
$\alpha\text{-Amino N and proline}$	31.86	17.06	35.92	25.93	42.4	45.1
Total N	276	336	459	–	–	–

Table 19.13 Nucleotides in beer (Qureshi *et al.*, 1979)

	Concentration ($\mu\text{g/ml}$)	Taste threshold (ppm)
5'-Cytidine monophosphate	1.8–7.8	–
2'-Cytidine monophosphate	2.3–7.3	–
3'-Cytidine monophosphate	16.8–73.3	–
5'-Adenosine monophosphate	12.4–67.6	–
5'-Guanosine monophosphate	1.1–4.9	35
3'-Adenosine monophosphate	1.6–10.7	–
5'-Uridine monophosphate	2.8–9.1	1.7–4.5
2'-Adenosine monophosphate	1.3–5.5	–
3'-Uridine monophosphate	1.5–10.3	–
2'-Uridine monophosphate	9.3–26.2	–
3'-Guanosine monophosphate	1.6–5.1	–
5'-Thymidine monophosphate	2.0–11.9	–
5'-Inosine monophosphate	1.5–4.7	120
3'-Inosine monophosphate	1.3–8.1	–
3'-Thymidine monophosphate	1.4–6.6	–
2'-Guanosine monophosphate	2.4–6.7	–

also examined the small peptides ($M_r < 1,000$) present in beer and found them rich in glutamic acid residues. The bulk of the amino acids present in wort are assimilated for yeast growth during fermentation so beers contain only low levels of amino acids. Some analyses of the amino acids found in beers are given in Table 19.12. It will be seen that proline (**4.44**) predominates; this imino acid is scarcely metabolized during fermentation so that the level in beer is between 121–354 ppm or between 4 and 10% of the total N. The ethyl esters of valine, leucine and isoleucine have been detected in beer (Peppard and Halsey, 1981).

Few of the nucleic acids present in barley survive malting and mashing but their degradation products, the phosphorous-containing nucleotides (Table 19.13), nucleosides and purine and pyrimidine bases (Table 19.14) are present in beer. Guanosine, uridine and cytosine are the major constituents. Dale and Lyddiatt (1994) found the following levels of purine nucleosides in 18 commercial beers (mg/l): guanosine + deoxyguanosine, 19–110; adenosine + deoxyadenosine, 3–43; xanthine, 1–41; guanine, <1–11; and adenine, <1–7 (they did not measure pyrimidine derivatives). Other non-volatile nitrogenous constituents of beer include choline (**4.101**) (200–250 ppm), tryptophol (**19.5**) (0.8–3.6 ppm), and nicotinic acid (**19.6**, pyridine-3-carboxylic acid) (4.5–8.6 ppm). This last acid is a B vitamin, essential for human growth. Ethyl nicotinate (1.5 ppm) and traces of the methyl, 3-methylbutyl, and phenethyl esters have been found in beer (Tressl *et al.*, 1977). Ethyl nicotinate and *o*-aminoacetophenone (**19.7**), also found in beer

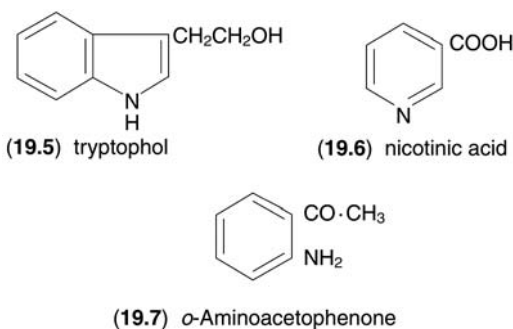

Table 9.14 Purines, pyrimidines and nucleosides in beer (Qureshi *et al.*, 1979)

	Concentration ($\mu\text{g/ml}$)
Cytosine (4.58)	11–24.6
Cytidine	18–41
Guanine(4.57)	0.2–3.2
Adenine (4.56)	0.8–5
Uracil (4.59)	1.0–4.6
Uridine	21–70.3
Adenosine	12.5–24.3
Xanthine (4.63)	2.8–9.7
Inosine	1.0–2.4
Guanosine	45–139
Thymidine	7–19.8

Table 19.15 Amides in dark German beer (Tressl *et al.*, 1977)

	Concentration (ppb)	
<i>N,N</i> -Dimethylformamide	H.CONMe ₂	15
<i>N,N</i> -Dimethylacetamide	CH ₃ .CONMe ₂	10
<i>N</i> -Methylacetamide	CH ₃ .CONHMe	+
<i>N</i> -Ethylacetamide	CH ₃ .CONH.CH ₂ Me	20
<i>N</i> -(2-Methylbutyl)acetamide	CH ₃ .CONH.CHMe.CH ₂ CH ₂ Me	10
<i>N</i> -(3-Methylbutyl)acetamide	CH ₃ .CONH.CH ₂ CH ₂ . CHMe ₂	25
<i>N</i> -Furfurylacetamide		120
<i>N</i> -(2-Phenylethyl)acetamide	CH ₃ .CONH.CH ₂ CH ₂ C ₆ H ₅	15

(10 ppb), have been associated with stale grainy flavours in beer at 2,000 and 5 ppb respectively (Palamand and Grigsby, 1974). Some amides present in beer are given in Table 19.15 but both they and the heterocyclic compounds formed during wort boiling (Chapter 9) are slightly volatile. Nevertheless, many survive into beer (Table 19.16) although the concentrations found are usually below the threshold values. Low levels of pyrroles have also been found in beer (Table 19.17).

Volatile

The biogenic amines and polyamines in beer have been reviewed by Kalač and Křížek (2003). At the pH of beer ammonia and the volatile amines found in beer (Table 19.18) are present as their non-volatile salts. Ammonia is the most abundant volatile nitrogenous constituent. The mean value in a range of US beers was 14.6 ppm (3–33 ppm) compared with 21.3 ppm (0–33 ppm) in imported beers (Owades and Jacevac, 1959). At the low concentrations found the volatile amines will have little influence on the flavour of beer. After ammonia, dimethylamine is the major component of this class. Tyramine (4.68), the decarboxylation product of tyrosine, has been detected in beer. Patients being treated for depression with monoamine oxidase inhibitors must avoid alcoholic drinks and yeast products due to the build up of toxic levels of tyramine. Traces of ethyl carbamate (urethane, H₂N.CO₂C₂H₅), which is reported to be carcinogenic, have been found in many fermented and distilled beverages. In a survey of 933 samples of Scotch whisky 15–115 ppb (mean 43 ppb) of ethyl carbamate were found but in a similar survey of 69 beers, Canas *et al.* (1989) found that 30 beers had between one and four ppb, two had between 9 and 13 ppb but in the majority ethyl carbamate could not be detected.

Table 19.16 Some heterocyclic bases present in beer (Harding *et al.*, 1977)

	Concentration (ppm)*	Threshold in light ale (ppb)
Pyridine (9.33)		
2-Acetylpyridine (9.42)		100
3-Acetylpyridine		
Pyrazine (9.34)	19–48.5	
Methylpyrazine	201–279 (410–419)	1000
2,3-Dimethylpyrazine	0.9–6.5	20
2,5-Dimethylpyrazine	3.4–12.3	50
2,6-Dimethylpyrazine	2.3–16.2	100
Ethylpyrazine	5.9–11.7	
2-Ethyl-5-methylpyrazine	5.4–35	
2-Ethyl-6-methylpyrazine	0.5–3.4	
Trimethylpyrazine	0.7–7.7	100
2-Ethyl-3,5-dimethylpyrazine	6.5–24.6	
2-Ethyl-3,6-dimethylpyrazine	1.9–13.8	50
2-Ethyl-5,6-dimethylpyrazine		
Tetramethylpyrazine	9.2–62.0	200
Acetylpyrazine	8.1–19.2	100
6,7-Dihydro-5 <i>H</i> -cyclopentapyrazine		
2-Methyl-6,7-dihydro-5 <i>H</i> -cyclopentapyrazine		
Thiazole (9.32)		
2-Furanmethanol (9.20)		
Furfural (9.17)		
2-Acetylfuran (9.25)	4–97	80 000
Dihydro-2(3 <i>H</i>)furanone		
Dihydro-5-methyl-2(3 <i>H</i>)furanone		
5-Methyl-2-furfural (9.22)		
2-Thiophenecarboxaldehyde (9.19)		
2-Acetylthiophene (9.27)		
5-Methyl-2-thiophenecarboxaldehyde (9.24)		

* Qureshi *et al.* (1979)

As mentioned above, secondary amines, such as dimethylamine, can react with oxides of nitrogen to form carcinogenic *N*-nitrosamines:

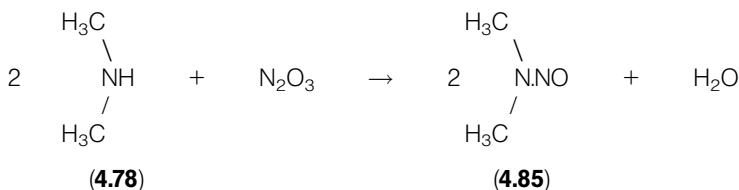

N-Nitrosodimethylamine has been found in beer and many other foodstuffs. German beers were found to contain 0–68 ppb (mean 5.9 ppb) *N*-nitrosodimethylamine while American beers had 0–14 ppb (mean 5.9 ppb). The highest levels were found in a dark strong German lager (maximum 47 ppb) and in *Rauchbier* (maximum 68 ppb). *N*-Nitrosodiethylamine and *N*-nitrosoproline have also been found in beer. After much research it was found that the nitrosamines were formed during the kilning of malt especially in direct fired kilns. Here the mixture of nitrogen oxides, NO_x, react with the amines present, probably hordenine, to form the nitrosamine. With this knowledge the level of nitrosamines in beer has been greatly reduced. Nevertheless in 1980 the US Food and Drug Administration set a limit of not more than 5 ppb of *N*-nitrosodimethylamine in beer and the ASBC describe a method to measure nitrosamines in beer.

Table 19.17 Pyrrole derivatives in beer (Tressl *et al.*, 1977)

	Concentration (ppb)
Pyrrole	+
2-Methylpyrrole	1800
2-Formylpyrrole (9.18)	30
2-Acetylpyrrole (9.26)	1400
2-Acetyl-5-methylpyrrole	10
2-Formyl-5-methylpyrrole (9.23)	110
2-Pyrrolidone	10
1-Methyl-2-pyrrolidone	+
1-Acetylpyrrole	+
1-Furfurylpyrrole	10
Indole	+

Table 19.18 Volatile amines present in beer (Slaughter and Uvgard, 1971)

	Concentration (ppm)
Methylamine (4.64)	
Ethylamine(4.65) ^a	0.03–2.12
<i>n</i> -Propylamine	
<i>n</i> -Butylamine	
Isobutylamine (4.66) ^b	0.05–0.10
<i>sec</i> -Butylamine	
<i>n</i> -Amylamine	
Isoamylamine	
Hexylamine	
1,3-Diaminopropane	
1,4-Diaminobutane (4.74 , putrescine)	
1,5-Diaminopentane(4.75 , cadaverine)	
<i>N,N</i> -Dimethyl-1,4-diaminobutane	
Dimethylamine (4.78) ^b	0.07–0.78
Diethylamine	
Di-isobutylamine	
Pyrrolidine (4.71)	
Trimethylamine (4.79) ^b	0.02–0.06
Tripropylamine	
<i>N,N</i> -Dimethylbutylamine	
Ethyl carbamate (4.87 , urethane)	0–0.013
Ethanolamine	
<i>p</i> -Hydroxybenzylamine ^c (4.80)	0.16–0.72
Tyramine (4.68)	0.15
Histamine (4.69) ^d	0.08–0.55

a Palamand *et al.* (1969)

b Koike *et al.* (1972)

c Slaughter and Uvgard (1972)

d Chen and Van Gheluwe (1979)

19.1.6 Sulphur-containing constituents

Beers contain 100–400 ppm of sulphate (Table 19.3). The major non-volatile organic sulphur compounds in beer are the amino acids cyst(e)ine and methionine and the peptides and proteins which contain them. Some of these compounds will survive into beer. In addition malt contains *S*-methylmethionine (**4.157**) and dimethyl sulphoxide (**4.160**) which are precursors of dimethyl sulphide (**4.158**). Hops may be a source of sulphur; they may be dusted with elemental sulphur before burr but the burning of

sulphur on the oast is less common today. The sulphur compounds in hop oil are discussed in Chapter 8.

The analysis of volatile sulphur compounds is quite difficult as additional compounds may be formed if the sample is heated or exposed to light and/or oxygen. Headspace analysis using a flame photometric detector is probably the most satisfactory technique. Peppard (1985) describes purging beer (sulphur) volatiles, their absorption in a Poropak Q trap, and their subsequent desorption onto a fused silica WCOT capillary column. The volatile sulphur compounds which have been identified in beer are listed in Table 19.19.

Brewery fermentations can produce up to 10 mg/l of sulphur dioxide and sodium (or

Table 19.19 Volatile sulphur compounds in beer

Compound	Typical levels ($\mu\text{g/l}$)	Flavour threshold ($\mu\text{g/l}$)	Flavour description
Hydrogen sulphide	1–20	5	Sulphidic, rotten eggs
Sulphur dioxide	200–20,000	>25,000	Sulphitic, burnt match
Carbon oxysulphide	–	–	–
Carbon disulphide	0.01–0.3	>50	–
Thioformaldehyde	–	–	–
Methanedithiol (Dithioformaldehyde)	–	–	–
Thioacetone	–	–	–
Methanethiol	0.2–15	2.0	Putrefaction, drains
Ethylene sulphide	0.3–2.0	20	–
Ethanethiol	0–20	1.7	Putrefaction
Propanethiol	0.1–0.2	0.15	Putrefaction
1,1-Dimethylethanethiol	–	–	–
2-Furfurylmercaptan	–	–	Rubbery
Dimethyl sulphide	10–100	30	Sweetcorn, tin
Diethyl sulphide	0.1–1.0	1.2	Cooked vegetables
Dimethyl disulphide	0.1–3	7.5	Rotten vegetables
Diethyl disulphide	0–0.01	0.4	Garlic, burnt rubber
Dimethyl trisulphide	0.01–0.8	0.1	Rotten vegetables, onion
<i>n</i> -Butyl methyl sulphide	1	–	–
Methionol	50–1,300	2,000	Raw potatoes
Methional	20–50	250	Mash potatoes, soup- like
Methyl thioacetate	5–20	50	Cabbage
Ethyl thioacetate	0–2	10	Cabbage
3-Methylthiopropionic acid	–	–	–
Ethyl	–	–	–
3-Methylthiopropionate	5–180	–	–
3-Methylthiopropyl acetate	–	–	–
2-Methyltetrahydro-thiophen-3-one	–	–	–
<i>S</i> -Methyl	–	–	–
2-Methylbutanethiolate	–	1	–
<i>S</i> -Methyl	–	–	–
4-Methylpentanethiolate	–	15	–
<i>S</i> -Methyl hexanethiolate	–	1	–
4-(4-Methylpent-3-enyl)-3,6-dihydro- 1,2-dithiine	–	–	–
3-Methyl-2-butene-1-thiol	0.001–0.1	0.01	Skunk, leek-like, light struck

potassium) metabisulphate may be added as a preservative either during conditioning or at racking. However, EEC regulations (1987) have limited the level of SO₂ in packaged beer to 20 mg/kg and to 50 mg/kg in cask conditioned beers. In contrast, 160–400 mg/kg SO₂ are allowed in wine and 200 mg/kg in cider. Much of the sulphur dioxide in beer is in a bound form such as the acetaldehyde bisulphite compound. There are several approved methods for the analysis of sulphur dioxide in beer. *Analytica-EBC* and the Institute of Brewing use the classic Monier-Williams distillation method in which the SO₂ is distilled in a current of nitrogen or carbon dioxide into hydrogen peroxide and the sulphuric acid formed titrated with standard sodium hydroxide. The ASBC describe a method whereby the colour which is restored to acid-decolourised *p*-rosaniline hydrochloride is measured. In a collaborative trial (Baker and Upperton, 1992) these two methods gave better precision than the IoB rapid method or the EBC dithiobisnitrobenzoic acid method. However, concern has been expressed about the possible carcinogenic nature of *p*-rosaniline.

Analytica-EBC also describes an enzymatic method for sulphur dioxide. Sulphite is oxidized to sulphate by the enzyme sulphite oxidase (SO₂.OD):

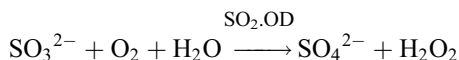

The hydrogen peroxide produced is reduced by the enzyme NADH-peroxidase (NADH-POD):

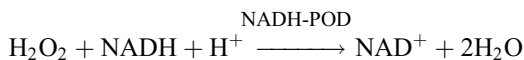

and the NADH is measured by its absorption at 340 nm. The level of SO₂ in beer seldom exceeds the flavour threshold and declines during storage with a half life between 37 and 221 days; in one beer a half life of 1,038 days was found (Ilett *et al.*, 1996).

The hydrogen sulphide present in beer is also partly in a bound form but the total level may exceed the threshold level. At this low level the flavour impact is not unpleasant and is characteristic of the flavour of ales especially cask conditioned ales which may have had potassium metabisulphite added as a preservative. Lager yeasts are less efficient in reducing SO₂ to H₂S than ale yeasts. In a vigorous fermentation much of the H₂S will be removed with the carbon dioxide. Yeast autolysis or microbial infection, e.g., by *Zymomonas* spp., can also produce hydrogen sulphide. The amounts of methanethiol, ethanethiol and propanethiol in beer (Table 19.19) probably exceed their flavour thresholds.

Dimethyl sulphide (4.158, DMS) is an important component of the flavour of lager beers. The concentration in a range of beers, given in Table 19.20, shows the higher levels in lager beers. As mentioned above it is mainly formed by the breakdown of *S*-methylmethionine present in malt. Lightly kilned lager malts will retain more *S*-methylmethionine than ale malts. Some brewers specify the level of *S*-methylmethionine in the malt they buy. DMS formed during kilning and wort boiling will be lost to the atmosphere but that formed in the whirlpool and during later processing is likely to remain in the wort unless vapour stripping is employed. Some DMS will be purged with the CO₂ during fermentation but some will survive into beer. During kilning some *S*-methylmethionine is converted into dimethyl sulphoxide (DMSO) which is not as volatile as DMS but soluble in water so it will survive into wort. Here some yeast strains are capable of reducing it back to dimethyl sulphide. Late or dry hopping with whole hops,

Table 19.20 Dimethyl sulphide content of beer (ppb)

British ales	14	Sinclair <i>et al.</i> (1970)
British lagers	16–27	Sinclair <i>et al.</i> (1970)
Continental lagers	44–114	Sinclair <i>et al.</i> (1970)
Beer from green malt	80	Anderson <i>et al.</i> (1975)
German lagers	32–205 (av. 94)	Narziss <i>et al.</i> (1979)
Diet beer	46–98 (av. 63.5)	Narziss <i>et al.</i> (1979)
Canadian ale	92	Hysert <i>et al.</i> (1979)
Canadian lager	114	Hysert <i>et al.</i> (1979)
Canadian low-alcohol beer	82	Hysert <i>et al.</i> (1979)
British	41–75	–
German	141–153	–
United States	59–106	–

will add as much as 15 ppb to the beer dimethyl sulphide level (Moir, 1994). Hegarty *et al.* (1995) found that 2-phenylethanol can suppress the flavour intensity of dimethyl sulphide. Dimethyl sulphide in beer is usually estimated by headspace gas chromatography with a capillary column. A flame photometric detector is specific for sulphur compounds but a flame ionization detector gives similar results for DMS and also allows measurement of acetaldehyde, ethyl acetate, *n*-propanol, isobutanol and isoamyl alcohol (*Analytica-EBC*, IoB, Dupire, 1999) (see also Mundy, 1991). 3-Methylthiopropionaldehyde was found to contribute the warty flavour to alcohol-free beers (Perpete and Collin, 1999). The same compound is the precursor of dimethyl trisulphide.

As discussed in Chapter 8, photolysis of the iso- α -acids in the presence of a sensitizer (riboflavin) and a suitable sulphur donor can produce a light- or sun-struck flavour. This is due to 3-methyl-2-butene-1-thiol (**8.48**, prenyl mercaptan) which produces a skunk-like, leek-like aroma with an extremely low threshold of 10 ng/l (0.10 ppb). To avoid this off-flavour few beers are now bottled in clear glass bottles. Alternatively the beer may be bittered with either tetrahydroiso- α -acids or ρ -iso- α -acids which are not affected by light.

19.2 Nutritive value of beer

The nutritional aspects of beer are discussed by Baxter and Hughes (2001). The calorific (caloric, energy) value of beer is calculated from the alcohol, carbohydrate and protein contents. The (UK) Food Labelling Regulations (1980) give the following figures for calculating calorific values: 1 g carbohydrate (as monosaccharide) = 3.75 kilocalories, 1 g protein = 4 kcal, 1 g fat = 9 kcal, and 1 g alcohol = 7 kcal. Accordingly the IoB give the formula:

$$\text{Calorific value (kcal/100 ml)} = 7(A) + 3.75(C) + 4(P)$$

where A = alcohol content/100 ml, C = total carbohydrate (as glucose)/100 ml, and P = protein content/100 ml (Martin, 1982). Alternatively, the result may be expressed in kilojoules (1 kcal = 4.184 kJ):

$$\text{Energy value (kJ/100 ml)} = 29(A) + 17(C) + 17(P)$$

Some typical energy values are given in Table 19.21. It can be seen that alcohol contributes more energy than the carbohydrates so low carbohydrate ‘lite’ beers can have

Table 19.21 Calorific (energy) values of beer

Beer type	Energy kJ/100 ml	Value kcal/100 ml
'Lite' beers	75–110	20–26
Lagers	85–125	20–30
Ales	114–160	25–38
Stouts/strong beers	150–300	35–70

From Baxter and Hughes (2001)

Table 19.22 Vitamin content of beers

Vitamin (mg/l)	Range in beers (mg/l)	Typical level in UK beer
Niacin	3–20	7.7
Riboflavin	0.07–1.3	0.3
Pyridoxine (B ₆)	0.13–1.7	0.5
Folates	0.03–0.10	0.05
Biotin	0.007–0.018	0.01
B ₁₂	0.09–0.14	0.1
Pantothenic acid	0.5–2.7	0.9
Thiamine	0.002–0.14	0.03

After Baxter and Hughes (2001)

high energy values due to the alcohol present. However, in some countries the term 'lite' refers to low-alcohol beers.

The ASBC use slightly different figures to calculate the caloric content of beers (i.e. 1 g carbohydrate = 4 kcal and 1 g alcohol = 6.9 kcal) and take into account the ash content of the beer so that:

$$\text{Caloric content (kcal/100ml beer)} = 6.9(A) + 4(B - C)$$

where A = Alcohol (% by weight), B = Real extract (% by weight), and C = ash content (% by weight). Beer is a rich source of certain vitamins (Table 19.22). Baxter and Hughes (2001) discuss the contribution that beer can make to the required daily intake of the vitamins.

19.3 Colour of beer

The physical properties assessed by a beer drinker include colour, clarity, viscosity and foam. Obviously if the beer is drunk directly from a can or bottle these properties will have less impact on the consumer. The colour of beer is largely due to the melanoidins and caramel present in the malt and adjuncts used but further caramelization can take place during wort boiling (see Chapters 9 and 10). Minor adjustments of the colour of beer can be made by the addition of caramel either to the copper or with the primings. Other contributors to the colour of beer are oxidized polyphenols especially in the presence of trace metals such as iron or copper. In pale beers the yellow vitamin riboflavin ($< 1 \mu\text{M}$) may significantly contribute to the colour.

The measurement of the colours of worts, beers and caramel solutions is difficult because the absorption spectra (Fig. 19.2) show no maxima. As long ago as 1893 Lovibond developed a series of coloured glass discs to match against the colour of beer.

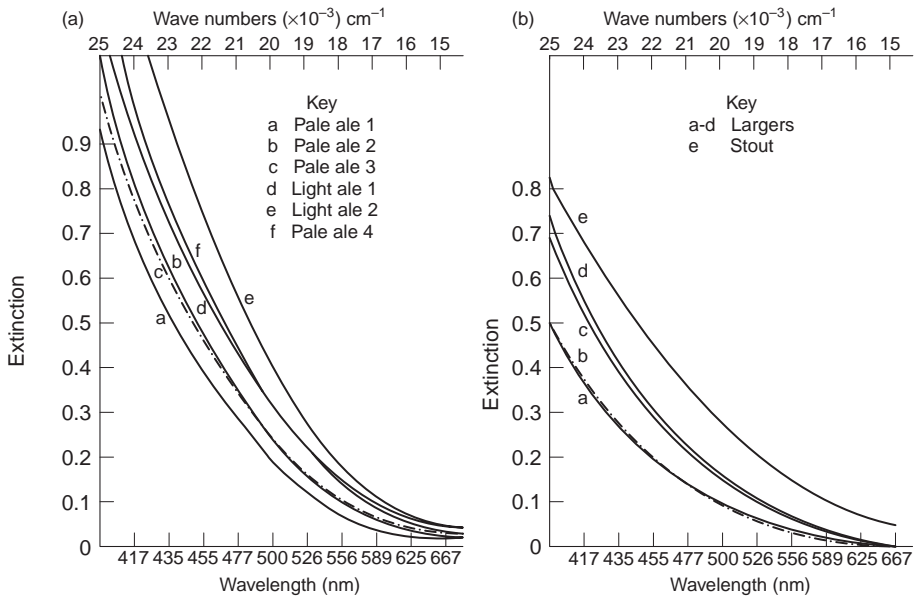

Fig. 19.2 (a) Spectra of commercial ales; (b) spectra of lager and stout (Hudson, 1969).

A new series of glass discs were released in 1950 and adopted by the EBC. The discs (2–27 EBC colour units) were matched against the beer in either 5, 10, 25 or 40 mm cells. However, it is necessary that every person entrusted to the measurement of the colour of worts and beers in this way is known to be free from colour blindness: 10% of the male and 1% of the female population do not have perfect colour vision. Ishihara (1964) has provided tests for colour blindness. In view of these difficulties spectrophotometric measurements at one wavelength were adopted. *Analytica-EBC* chose measurements at 430 nm in a 1 cm cell when:

$$\text{EBC Colour} = A_{430} \times 25$$

Originally the Institute of Brewing chose measurements at 530 nm as being more suited to ales but later adopted 430 nm. The ASBC also take measurements at 430 nm but in a half-inch cell when:

$$\text{Color (ASBC)} = A_{430} \times 10$$

Nevertheless, single wavelength measurements can provide only limited information. In the human eye cone cells in the centre of the retina respond to either red (c. 600 nm), green (c. 550 nm) or blue (c. 450 nm) light and send three signals to the brain which are there integrated and interpreted as colour. Hence tristimulus values are being increasingly used to measure the colour of beers (Sharpe *et al.* 1992, Smedley, 1992, 1995).

When evaluating colour the energy of the illuminant light source across the visible spectrum ('colour temperature') must be taken into consideration. The Commission Internationale de l'Eclairage (CIE) have defined a number of standard illuminants: Illuminant B (colour temperature, 4,900 K) represents sunlight, Illuminant C (6,800 K) represents average daylight, and Illuminant D65, which is most commonly used, represents daylight with some UV correction. The CIE defines colour in terms of three parameters: hue (h°), value (L^*), and chroma (C^*) as illustrated in the CIELAB colour

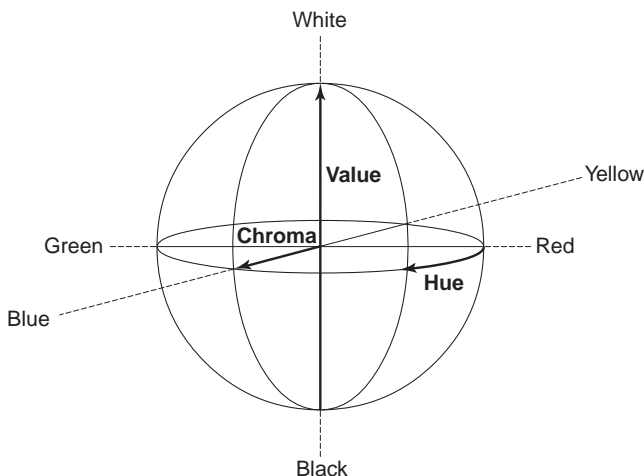

Fig. 19.3 A representation of the CIELAB colour space showing the relationship between value, hue and chroma (Smedley, 1995)

space (Fig. 19.3). ‘Hue’ is the term ascribed to what we generally consider as the prominent ‘colour’ of an object. The hues, red, yellow, green, blue and purple form a continuum in the horizontal plane of the colour space which is sometimes called the colour wheel (Sharpe *et al.*, 1992). It should be noted that the hue (h) is a measure of angular rotation. The value (L^*) is a measurement of ‘light’ and ‘dark’ and is a vertical displacement from the north pole (white) to the south pole (black). The chroma (C^*) measures what observers call ‘dull’ or ‘vivid’ and is a horizontal displacement of the vertical axis of the colour space towards the circumference. For dealing with differences in colour between two samples it is generally more convenient to express locations within the colour space using Cartesian co-ordinates. Here, hue and chroma are combined into two parameters a^* and b^* so:

$$\text{Chroma } (C^*) = a^{*2} + b^{*2}$$

and

$$\text{Hue } (h^\circ) = \tan^{-1}(b^*/a^*)$$

Commercial tristimulus transmission instruments are available which record colour in terms of L^* , a^* and b^* . There is a linear relationship between L^* and EBC colour units but tristimulus measurements can distinguish between beers showing the same EBC colour values (Smedley, 1995). The ASBC have recommended the use of tristimulus analysis for measurement of beer colour (Cornell, 2002).

19.4 Haze

Clarity is the absence of haze. Most drinkers expect their beer to be bright and clear and may reject cloudy beer untasted. Beer hazes are of two types: biological and non-biological. Infection of bright beer with either bacteria or wild yeasts will produce a biological haze due to the growth of the invading organism when the beer will usually become sour and unacceptable. With the use of pasteurization and sterile filtration,

biological infection and haze formation is fairly rare. However, sterile beers kept for a length of time will develop a non-biological haze. The rate of development of such hazes determines the shelf-life of bottled and canned beers. Before beer shows any haze at room temperature (20 °C) it may form a chill haze if cooled to 0 °C. Such chill hazes will redissolve at 20 °C when permanent hazes will remain. Chill hazes are obviously more of a problem with lager beers, which may be served as cold as 4 °C, than with ales. Beer haze has been reviewed by Bamforth (1999) and by Siebert (1999).

19.4.1 Measurement of haze

The amount of chill haze isolated for an EBC collaborative analysis from three different breweries was between 1.4 and 8.1 mg/l while the permanent haze accounted for 6.6–14.6 mg/l (Carrington *et al.*, 1972). The amount of permanent haze increases with time of storage and yields of up to 44 mg/l have been reported but beers are commercially unacceptable long before the haze can be measured gravimetrically. When light is passed through a suspension of a coloured precipitate and the amount of reflection is negligible, the light absorption gives a measure of the turbidity according to Lambert's law. With white precipitates, such as beer haze, much of the light is reflected so measurements are made of the light reflected at a given angle to the incident light (nephelometry). The angle chosen and the size of the haze particles are the two most important factors which determine the amount of haze perceived (Thorne and Nannsted, 1960). Most of the commercial instruments in use today take measurements at 90° to the incident light: the exception is the Monitek 251 which takes readings at a forward angle of 13°. The wavelength of the incident light also varies between instruments (350–860 nm) and some instruments are more sensitive to colour than others (Buckee *et al.*, 1986). Mundy and Boley (1999) concluded that there are significant differences between the haze values obtained on the same sample with different instruments, confirming that the results obtained on different instruments cannot be directly compared. The EBC, IoB and ASBC all use formazin, prepared by the reaction between hydrazine sulphate and hexamethylenetetramine, as the primary haze standard. Unfortunately the EBC and the ASBC have adopted different scales so:

10,000 ASBC Formazin Turbidity units = 145 EBC Formazin haze units

1 EBC haze unit = 69 ASBC haze units

Earlier, barium sulphate (Helm) and fullers' earth were used as standards. A comparison of the different scales with visual assessment is given in Fig. 19.4. Styrene-divinylbenzene copolymer suspensions (AEPA) have also been used as turbidity standards but samples from different suppliers had different mean particle sizes. Coulter counter analyses showed that the majority of the particles in the Formazin haze standard were between 1.5 µm and 2.5 µm diameter (mean 2.1 µm) (Morris, 1987). In most cases visual assessment of beer haze correlates well with instrument readings for light scattered at 90° but some beers which appear bright to the eye give substantial meter readings. Such beers were said to contain 'invisible' or 'pseudo' haze. These 'pseudo' hazes were not observed with instruments using 13° forward light scattering. Morris (1987) investigated the relationship between haze and particle size. He found that the 90° (Radiometer) haze meter gave results which can be closely related to turbidity for particles > 0.5 µm in diameter but for particles < 0.5 µm it was somewhat oversensitive. A high reading will therefore be obtained for a suspension containing particles < 0.5 µm

Comparison of haze scales

It must be stressed again that no exact equivalence must be expected between different haze scales or between visual observations made in different laboratories. However, a rough comparison between haze scales can be made with the help of this nomogram and with the relationship:

$$1 \text{ EBC Formazin Haze Unit} = 40 \text{ Helm units} = 69 \text{ ASBC Formazin units}$$

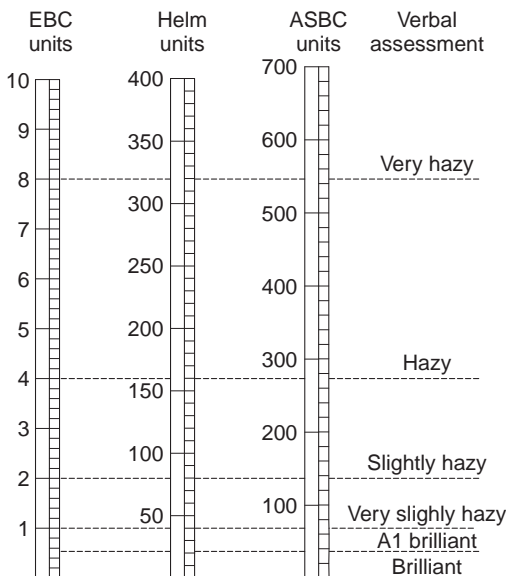

Fig. 19.4 Comparison of haze scales (*Analytica-EBC*, 1998).

diameter if the calibration was originally carried out with particles $> 0.5 \mu\text{m}$, which explains the observation of 'invisible' or 'pseudo' haze.

19.4.2 Composition and formation of haze

The most common non-biological hazes found in beer are formed by interactions between proteins and polyphenols. Chill hazes contain between 45.5 and 66.8% of proteins, the hydrolysates of which are rich in glutamic acid, proline, arginine and aspartic acid residues. Alkaline hydrolysis of beer hazes produces a range of phenolic acids including: ferulic, sinapic, vanillic, syringic, gallic, protocatechuic and caffeic acids (Harris, 1965). In contrast, acid treatment of beer hazes liberates the pigments cyanidin and delphinidin showing the presence of proanthocyanidins in beer haze. However, none of the proanthocyanidins found in malt, hops and beer contain a methoxy group so the ferulic, vanillic, sinapic, and syringic acids produced on alkaline hydrolysis must come from another source probably lignin. Barley straw lignin contains 16.4% methoxyl so, on the assumption that all the methoxyl in haze is derived from lignin and that this lignin has the same composition as barley straw lignin, hazes contain 5.7–7.9% lignin (Harris, 1965). Hazes contain 0.7–3.3% of ash rich in many metals (Hudson, 1955). Some of the metals, e.g., copper, iron and aluminium, are concentrated in haze up to 80,000 times the level in the residual beer. Hazes also contain 2–4% of glucose and traces of the pentoses arabinose and xylose.

During wort boiling (Chapter 9) some protein is removed in the hot break or trub but protein-polyphenol complexes, which dissociate at 80 °C, are not found in the hot break but do occur in the cold break. Proteins not removed during wort boiling may survive fermentation and persist into beer where they may cause haze. However, not all proteins nor all polyphenols are haze-active. The suggestion that hydrophilic proteins are responsible for haze and hydrophobic proteins are necessary for head retention is probably too facile. Haze-active proteins or polypeptides in beer are mainly derived from the barley prolamins or hordeins, which are alcohol soluble and rich in proline. Indeed proline residues appear to be necessary for haze formation. In a model system with catechin and different polypeptides, haze increased linearly with the mole % proline in the polypeptide, the most haze being formed with polyproline. Polypeptides which contain little or no proline produce little or no haze. However, Ishibashi *et al.* (1996) found that antibodies raised against foaming polypeptides were specific for those compounds but antibodies raised against haze reacted with both haze and foaming polypeptides. It is suggested that albumin- and globulin-derived material may adhere to particles formed originally from hordein-derived polypeptides. Yang and Siebert (2001) investigated dyes that bind to proteins and found that bromopyrogallol red gave the best indication of haze-active protein.

Similarly, not all the polyphenols present in beer are haze-active; proanthocyanidins and flavanols are the most important. Catechin, epicatechin and galocatechin give small amounts of haze with a beer haze-active protein, but the dimers, e.g., procyanidin B-3, produce much more haze and the trimers more again. As mentioned above, tetramers and pentamers do not survive into beer but they may reform by oxidation as beers age. Of the dimers, prodelfinidin B-3 produces more haze than procyanidin B-3. The amount of haze formed depends on the concentrations of both the protein and the polyphenol and their ratio. Siebert *et al.* (1996) produced a model for protein-polyphenol interactions (Fig. 19.5) in which both the polyphenols and the haze-active proteins have a fixed number of binding sites (shown as two and three respectively in Fig. 19.5). When the number of polyphenol 'ends' equals the number of protein binding sites, the largest network with the largest particles will be formed which will show the greatest amount of light scattering. With an excess of protein, the polyphenol will form a bridge between two peptide chains but there will be insufficient for further bridges. With an excess of polyphenol relative to protein, all the protein binding sites will be occupied and it is unlikely that the free end of the polyphenol will find a vacant protein site for further cross-linking.

Occasionally hazes which differ from the normal protein-polyphenol haze are found in beer. These include calcium oxalate hazes (the solubility of calcium oxalate is only 6.07 mg/l at 13 °C) and carbohydrate hazes such as retrograded starch (α -glucan), β -glucans and pentosans (Chapter 15).

19.4.3 Prediction of haze and beer stability

The conditions to which any particular beer package will be subjected cannot be known beforehand; therefore two types of test are adopted by most breweries:

1. Long-term storage at a temperature related to that likely in trade with an examination for biological and non-biological haze at the end of a defined period (e.g. three or six months).
2. Accelerated haze production under defined high temperature conditions, to give an early indication of the liability to non-biological haze.

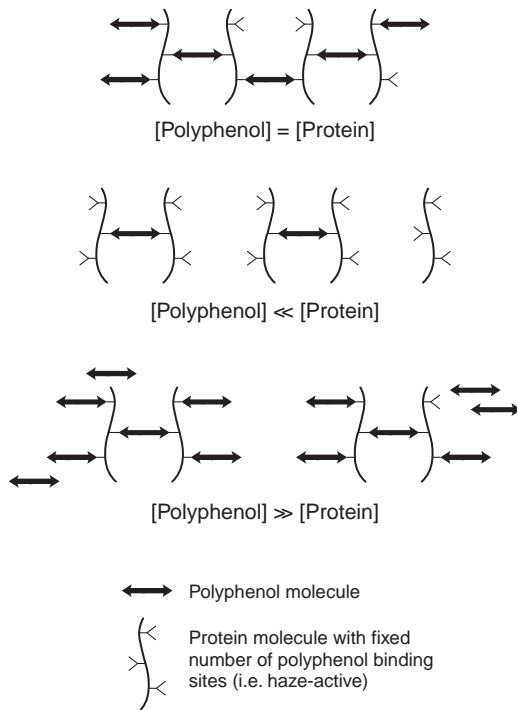

Fig. 19.5 Conceptual mechanism of protein-polyphenol interaction (Siebert *et al.*, 1996).
Copyright (1996) American Chemical Society

The EBC recommendation is to measure the increase in non-biological haze at the end of a defined period at a defined temperature. Brewers will adopt different conditions to suit their beers but for comparison the EBC recommends that six bottles should be cooled to 0 °C overnight and the initial haze read in the morning at 0 °C. The bottles are then placed in an upright position and without agitation, in a bath at 60 °C for 48 hours. At the end of this time they are again cooled at 0 °C overnight and the haze measured the following morning at 0 °C. The initial and final haze values are reported in EBC Formazin units.

The ASBC measure the total haze after chilling in a similar manner and describe accelerated chill haze tests. They suggest that 12 weeks or three months is a reasonable time in which beer can be expected to be sold. Accordingly, they recommend storing 24 bottles or cans at 22 °C ± 2 °C in a vertical position without agitation for eight weeks. Three containers are then cooled overnight at 0 °C and the haze measured at 0 °C. Each week, up to 12 weeks, three more containers are cooled and the haze measured. For the accelerated chill haze test three containers are held at the selected temperature (40, 50, or 60 °C) for one week. The samples are then cooled at 0 °C for 24 hours and the haze measured. (Note that caution should be exercised when the test is run at 60 °C because there is some danger that bottles may burst and cans may rupture.) The results of the accelerated chill haze tests, in Formazin Turbidity Units, are compared with the haze formed after 12 weeks at 22 °C to determine which forcing temperature gives results that correlate best with room temperature storage. Thereafter only that forcing temperature need be used routinely.

These accelerated shelf-life test take at least 48 hours or one week to give results. More rapid predictions of beer stability are sometimes obtained using chemical

precipitants. The IoB describe methods for sensitive protein in beer, alcohol chill haze in beer, and for the saturated ammonium sulphate precipitation limit of beer.

19.4.4 Practical methods for improving beer stability

Brewers wish to increase the shelf-life of their beers and adopt various strategies to achieve this, i.e., removal of protein, removal of polyphenols or removal of a portion of each (Chapter 15). This last method is usually employed since some proteins and some polyphenols are necessary for the character of the beer. To reduce the level of proteins some (lager) brewers used to treat their beers with proteolytic enzymes (papain, bromelain, ficin, or enzymes from *Bacillus subtilis*) but such treatment is likely to remove both haze-active and foam-active proteins. Similarly, treatment with bentonite, removes both types of protein but silica hydrogels are more specific for haze-active proteins (Siebert and Lynn, 1997). Apperson *et al.* (2002) studied the silica absorption of haze-active beer proteins and found that non-activated small pore volume silica (silica B) was one of the most efficient absorbers of isolated haze protein. Alternatively, tannic acid is a relatively efficient precipitant of haze-active proteins in beer.

Proanthocyanidin-free barley varieties have been bred and malted which, when used with a polyphenol-free hop extract, give colloiddally stable beers. However, most brewers still rely on absorbants to remove excess polyphenols. After nylon and polyvinylpyrrolidone (PVP), cross-linked polyvinylpyrrolidone, polyvinylpolypyrrolidone (PVPP) is now the agent of choice (McMurrough, 1995) often in conjunction with silica hydrogels. Two types of PVPP are available. The first, single-use PVPP which is a microized white powder with a high surface/weight ratio, is used in a filter aid bodyfeed dosing regimen. The second type is regenerable PVPP used either in impregnated sheets or within a horizontal leaf pressure vessel. These materials are regenerated by treatment with 1–2% sodium hydroxide, followed by washing and neutralization. According to Bamforth (1999), this last treatment is the cheapest. Siebert and Lynn (1998) compared polyphenol interactions with PVPP and haze-active protein. They concluded that the mechanisms by which haze-active polyphenols attach to PVPP and to haze-active proteins are similar but not identical.

19.5 Viscosity

Dynamic viscosity is defined as the resistance to shear flow within a liquid. Kinematic viscosity is a measure of the time taken by a liquid to flow through an orifice under gravity. Both are measured by an international method using the time of flow in an Ostwald viscometer at 20.0 °C. At this temperature the dynamic viscosity of water is 1.002 cP (centipoises) and the kinematic viscosity is 1.00 cS (centistokes). The SI unit for dynamic viscosity is the Pascal-second when 1 cP = 0.001 Pa.s. The EBC use a 20% w/v sucrose solution as an additional standard (1.945 cP) but the Institute of Brewing, following BS188: 1957, use a 3.0% w/v solution of glycerol. Some values are: worts (SG 1,030–1,100) 1.59–5.16, lager (SG 1,007) 1.45; and stout (SG 1,009) 1.96 cP. The method can be extended to measure the viscosity of liquid sugars and brewing syrups using a viscometer of the appropriate range.

The viscosity of wort and beer is influenced by the macromolecules present, Sadosky *et al.* (2002) found that arabinoxylan, β -glucans and dextrans all increased the viscosity of model solutions with the dextrans having the largest effect.

19.6 Foam characteristics and head retention

The vast literature on this subject has been reviewed by Bamforth (1985), Baxter and Hughes (2001) and Evans and Sheehan (2002). The European Brewery Convention (1999) have published the proceedings of a symposium on Beer Foam Quality, held in Amsterdam in 1998. Bamforth (1985) defined beer foam quality as a combination of its stability, quantity, lacing (adhesion or cling), whiteness, 'creaminess', and strength. Further, he provided evidence (2000) that consumers differ, along regional and gender lines, in their requirements for the amount of beer foam, its stability and whether it laces the glass. In England, draught beers from Burton-on-Trent are served with little or no foam but in the north-east a rich creamy head that overflows the glass is expected. This can cause problems when the glass is a legal measure. However, the judgment of UK law is that the customers' preference should be catered for. Thus the head can be considered an integral part of the pint or the drinker can demand a full pint of liquid.

Beer foams are colloidal systems comprising a continuous liquid phase and a discontinuous gas phase; the bulk density of the system approaches that of a gas rather than that of a liquid. Beer foam physics have been discussed by Ronteltap *et al.* (1991) and by Prins and van Marle (1999). Ronteltap *et al.* (1991) concluded that foam characteristics are determined by four key processes: bubble formation, drainage, coalescence, and disproportionation. Bubble formation requires a suitable site for nucleation. Bubbles may be generated in beer either by dispersal or condensation. The simplest dispersal system involves injection of a gas from a capillary. A spherical bubble forms at the tip of the capillary and will be released when its buoyancy is greater than the surface tension effects that hold the bubble to the tip of the capillary. Bubbles formed in this way are of similar size whereas those generated from a sinter will be more heterogeneous and more likely to undergo disproportionation. Homogeneous condensation occurs, for example, when a crown cork is removed from a bottle of beer at, say, 5 °C, when rapid gas expansion may cause the temperature to drop locally as low as -36 °C. Much more likely is heterogeneous condensation when the gas already present (usually air in the case of beer dispense) is expanded by diffusion of gas (either carbon dioxide or nitrogen) from the solution into the gas phase. As the bubble grows it experiences greater buoyancy until it breaks away from the nucleating surface leaving a small pocket of residual gas to begin the process again. So the nature and amount of gas in solution influence the beer foam (Fisher, *et al.*, 1999) as does the angle of dispense.

Etched glassware and small particles may provide nucleation sites but lose their effectiveness when totally wetted or not scrupulously clean. Agitation of beer can produce nucleation sites by cavitation, the instantaneous formation of a vacuum when the liquid separates from the vessel wall. Ultrasound can promote cavitation but often with uncontrollable gushing. Bubble formation involves an increase in the surface area of the liquid which is opposed by the surface tension of the liquid but bubbles remain stable because of materials of low surface tension within the bubble wall which have both hydrophobic and hydrophilic areas (e.g. proteins). Once a bubble leaves its nucleation site it will rise through the beer until it reaches the beer-air/foam interface. Surface active materials in the bubble wall may facilitate this movement. The nature of the gas within the bubble is important and the pressure within the bubble is inversely proportional to its diameter so gas will pass from smaller bubbles to larger ones (disproportionation). If the gas is soluble in the liquid film the passage of gas between the bubbles is faster. Thus foams containing oxygen and nitrogen produce smaller bubbles and a more stable foam than those containing carbon dioxide, which is more soluble in the liquid film. As the

spherical bubble leaves the beer-foam interface it will be pushed upwards by younger bubbles arriving from below. As it moves to the top of the head the liquid between the individual bubbles starts to drain away, the fresh wet foam is converted to dry foam and finally only a solid network of bubble walls remains which may be deposited from the liquid phase on to the glass showing cling, lacing, or foam adhesion. To the consumer foam drying or drainage results only in a modest change in foam volume but bubble coalescence or disproportionation, with the formation of larger coarser bubbles, is a more obvious sign of foam destabilization.

19.6.1 Methods of assessing foam characteristics

Methods have been devised for measuring many foam parameters such as foamability, foam stability, foam drainage, cling, viscoelasticity, lateral diffusion, film thickness and bubble size but most measurements concentrate on the rate of foam collapse or, inversely, the duration of head retention or foam stability. It is obvious that when dispensing beer either draught or from a bottle or can, one can make a rough assessment of foam stability and it has been suggested that the views of a panel on this are closer to the consumers' view of foam behaviour than the tests discussed below. All measurements should be made in a temperature-controlled room as the collapse of beer foam is very sensitive to temperature. Scrupulously clean glassware should be used in all the tests, for example, that washed with 2% trisodium phosphate solution.

Blom (1937) produced foam in a tared separating funnel by passing carbon dioxide through a Chamberland candle. The method is therefore applicable to worts and aqueous solutions containing foam-active substances. When the funnel is full of foam, the beer is run off and the funnel weighed. The beer is again run off and the residual foam weighed after intervals of one, two, three, and four minutes. Blom observed that the collapse of the foam was analogous to a first-order chemical reaction and the foam stability (K) was given by:

$$K = \frac{1}{t} \log \left(\frac{x}{(a-x)} \right)$$

where t = time (min.), a = initial weight of the foam, and x = final weight of the foam after time t . By substituting $a/2$ for x in this equation, K can be calculated from the half-life of the foam $t_{1/2}$. Blom found that beers with a half-life of 90 s have excellent head retention but values less than 80 s indicate poor head retention. Head retention values for a range of British beers, found using Blom's method, is given in Table 19.23. In Table 19.24 changes in head retention throughout the brewing process are recorded.

If air is passed continuously through a porous membrane into a liquid such as wort or beer there is a correlation between the volume of air (V) passing in time (t) and the average amount of foam produced (ν) so that:

$$\Sigma = \frac{\nu t}{\nu}$$

Σ is a measure of the life of a bubble in the foam. Ross and Clarke (1939) calculated that

$$\Sigma = \frac{t}{2.303 \log \frac{b+c}{2}}$$

where t is the time in seconds of the stationary phase of the head, b is the volume (ml) of the beer formed in that period, and c is the volume of beer given by the residual head and:

Table 19.23 Head retention (Blom) for production beers (Curtis *et al.*, 1963)

	OG	$t_{1/2}$ (s)
Pale ale	1,035	75
Pale ale	1,055	77
Brown ale	1,035	77
Strong ale	1,080	73
Sweet stout	1,046	89

Table 19.24 Changes in head retention (Blom) through the brewing process (Curtis *et al.*, 1963)

OG	1,035	1,055
Wort	115	–
Beer at rack	86	94
Fined beer	82	88
One day in bottle	78	–
One week in bottle	–	79
One month in bottle	80	–

$$\Sigma = 1.44t_{1/2}$$

They concluded that Σ was a property of the beer foam independent of the method used to produce it, the dimensions of the container and the temperature within a limit of 2 °C. However, this linear logarithmic decay breaks down when 95% of the foam has returned to the liquid phase.

The American Society of Brewing Chemists have adopted a method of Helm (1933), who worked at Carlsberg, in which beer is poured into a cylindrical separating funnel (75 mm o.d.) until the foam reaches the 800 ml mark. After 30 seconds, all the beer that has separated is drawn off, the stopwatch started and after 200 seconds the beer that has separated in that period is drawn off ('b' ml) and the time 't' noted (225–230 s). The remaining foam is then collapsed, with either isopropyl or butyl alcohol (2 ml) delivered with a fine pipette, and collected ('c' ml after deducting the volume of the defoaming agent). The sigma (Σ) value is then calculated according to Ross and Clarke's formula given above.

The Institute of Brewing have adopted a modification of Rudin's (1957) method. The apparatus (Fig 19.6) consists of a jacketed foam tube (26–28 mm dia.) and at least 350 mm tall mounted over a porosity 3 glass sintered disc. Degassed beer is added to the 10 cm mark and foamed with carbon dioxide to the 325 mm mark. As the foam collapses the time taken for the foam/beer boundary to traverse the distance between the 50 mm and the 75 mm marks gives a measure of the half life of the foam. The logarithmic rectilinear collapse of foams formed with carbon dioxide is four times faster than that for beers foamed with air or nitrogen so traces of air either in the CO₂ used for foaming or introduced into beer by pouring can cause departures from a regular logarithmic decay. The Institute of Brewing also approve the measurement of foam stability using a NIBEM meter (Klopper, 1973) (Fig 19.7). The foam is dispensed into a standard glass over which the meter head with a central electrode and four shorter needle electrodes is mounted. When the needle electrodes are in the foam the conductivity between the longer and shorter electrodes switches off the servomotor. As the foam collapses the conductivity is broken the servomotor engages and lowers the electrodes until they touch the surface of the foam again. After a 'wait' period, the time for the foam to collapse over 10, 20, and 30 mm is measured for a beer containing

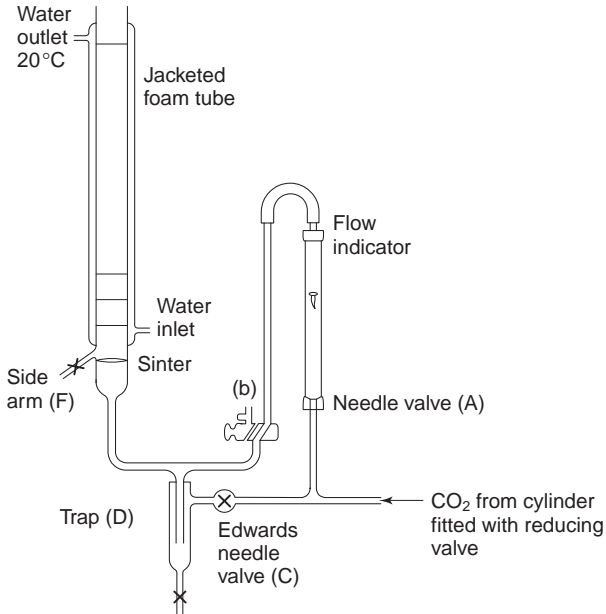

Fig. 19.6 Rudin head retention apparatus (Institute of Brewing, Methods of Analysis, 1997).

$> 3.4 \text{ g/l CO}_2$. For a beer containing $< 3.4 \text{ g/l CO}_2$ the collapse is measured over 5, 10, and 15 mm. The IoB Analysis Committee (Sharpe, 1997) found the precision of both the Rudin and the NIBEM methods was independent of the of the foam stability of the sample. However, the two methods ranked three beers differently, no doubt due to the different principles involved. A later model, the NIBEM-T meter, has protection against air movement and automatic temperature compensation. It gave better repeatability and reproducibility for the determination of foam stability in beer and has been accepted by the EBC Analysis Committee (Ferreira, 2003).

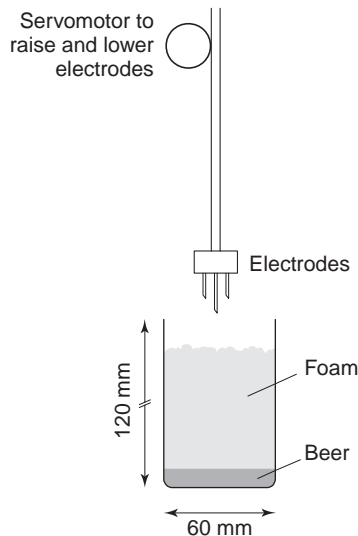

Fig. 19.7 NIBEM foam stability apparatus (after Klopper, 1973).

The American Society of Brewing Chemists also describe a foam flashing method for bottled beers. Under a positive pressure of 29 lb CO₂ the beer is foamed through a 0.79 mm (0.031 in.) orifice and 200 ml of foam are collected. The volume of the beer collapsed from the foam in 90 seconds is measured (B₁) and the remaining foam is collapsed with isopropyl alcohol (2 ml). If the total volume of beer produced from the collapse of 200 ml of foam, after subtraction of 2 ml of isopropyl alcohol, B₂ is then:

$$\text{Foam Value Units(FVU)} = \frac{200(B_2 - B_1)}{B_2}$$

Several workers prefer to use a standard orifice since it has been observed that variations in the porosity of Chamberland candles and sintered glass discs can influence the observed head retention. Ault *et al.* (1967), Klopper (1973), and Jackson and Bamforth (1982) have described methods for measuring cling, lacing or foam adhesion.

19.6.2 Beer components influencing head retention

Pure liquids do not give stable foams and many investigations have been carried out to characterize the surface-active substances in beer responsible for good head retention but it is obvious, for example, from the use of alcohols to collapse beer foams, that beer contains both positive and negative foam factors. Undoubtedly the most important positive foam factors in beer are polypeptides. Evans and Sheehan (2002) showed that measurement of beer proteins by the Bradford Coomassie Blue dye binding assay, which only measures proteins with MW > 5,000, correlated well with Rudin Head Retention Values. Earlier, Narziss and Röttger (1973) had found a good correlation between foam stability (Ross and Clarke, 1939) and the concentration of nitrogenous material with MW > 12,000 found by gel filtration. Slack and Bamforth (1983) fractionated beer proteins by hydrophobic interaction chromatography on Octyl-Sepharose CL-4B and found that the most hydrophobic polypeptides were the most foam active.

At least two barley proteins, protein Z and lipid transfer protein 1, survive the brewing process more or less intact. Protein Z (M_r c. 40 kDa), which accounts for 10–25% of the non-dialyzable protein in beer, can be resolved into two isoforms, Z4 (80%) and Z7 (20%). Evans *et al.* (1999) used ELISA to measure the levels of protein Z4, protein Z7, BSZ7b, and lipid transfer protein 1 (LTP 1) in 25 different malts which were subjected to pilot or small-scale brewing trials. Regression analyses correlated the foam stability (Rudin) of the beer with protein (Coomassie blue), protein Z4 (ELISA), free amino nitrogen (FAN), β-glucan, arabinoxylan, and viscosity. The levels of protein Z7 and LTP 1 were not correlated with the HRV: LTP 1 influences the quantity of foam generated which is not measured by Rudin's method. By multiple linear regression analysis Evans *et al.* (1999) found that the level of malt protein Z4 and the wort β-glucan level predicts 72% of the variation in foam stability.

Jegou *et al.* (2000) also found that LTP 1 and LTPb in barley grain survived in a modified form into beer. The modifications, which may influence foam promotion properties, include glycation with a number of hexose units and reduction of disulphide bonds. Some hordein-derived fragments are also enriched in beer foam (Evans and Sheehan, 2002). Varg *et al.* (1999) identified a 17 kDa protein in barley which is important for beer foam stability; this protein is partly modified into a more active form during mashing and/or wort boiling.

High molecular weight non-starch polysaccharides such as β-glucans and arabinoxylans increase beer viscosity thereby slowing the drainage of liquid from the foam and

improving its stability. In the trial brews mentioned above (Evans and Sheehan, 2002) viscosity was significantly correlated with HRV and with the non-starchy polysaccharides in beer. However, high levels of β -glucan and arabinoxylan are negatively correlated with beer filtration rate so the improvement of foam quality by increasing the level of non-starchy polysaccharides is not advised. Evans and Sheehan (2002) found in a trial brew that addition of Bioglucanase and Bio-cellulase during mashing degraded more than 75% of the β -glucan and reduced the viscosity and HRV of the beer but not the lacing index. In contrast, Lusk *et al.* (2001) found that no foam enrichment or foam stabilization occurred with β -glucan; it did not collect in the foam and treatment with β -glucanase did not alter beer properties.

The hop iso- α -acids are concentrated into beer foam. For example, when lager containing 25–26 ppm iso- α -acids (50 l) was foamed, the collapsed foam (2 l) contained 93–120 ppm iso- α -acids (Bishop *et al.*, 1974). Of the individual iso- α -acids, isohumulone and isoadhumulone are concentrated into the foam more than isocohumulone. Similarly, unhopped beer bittered (to 21.0 BU) with isohumulone had a better head retention ($\Sigma = 132$) than that bittered with isocohumulone ($\Sigma = 115$) (Diffor *et al.*, 1978). The reduced iso- α -acids stabilize foam more than their unsaturated parents. Baker (1990) added reduced iso- α -acid preparations to unhopped beer and found that, in particular, foam collapse times of beers treated with tetrahydroiso- α -acids and hexahydroiso- α -acids increased significantly with each incremental addition. The foam produced with hexahydroiso- α -acids was unnaturally dense but tetrahydroiso- α -acids can be added to beer to improve the head retention. The amounts that can be added are limited by their more potent bitterness (Table 8.3) but the addition of 3–5 mg/l of tetrahydroiso- α -acids can effectively stabilize beer foam.

Similarly, Weiss *et al.* (2002), using a NIBEM foam stability meter, found that ρ -iso- α -acids slightly improved the foam stability but the tetrahydroiso- α -acids showed a more dramatic effect. In the presence of iso- α -acids metal ions improve beer foaming. Hughes and Simpson (1995) proposed that metals such as Mn^{2+} , Al^{3+} , and Ni^{2+} cross link the iso- α -acids (Fig 19.8) to strengthen the bubble film. It is well known that polyphenols react with proteins but despite this they do not appear to have a large effect on foam stability. In contrast, melanoidins can form stable foams in the absence of protein as they slow the drainage of liquids from the foam. Finally, the pH of the beer influences foam stability; the lower the pH the more stable the foam. This may be due to the fact that at lower pH values the iso- α -acids are less ionized and more hydrophobic.

Traditionally, the only gas in beer was carbon dioxide but in 1964 Guinness introduced a draught stout with a mixture of carbon dioxide and nitrogen for dispense. The nitrogen gave the beer its characteristic creamy head since it produces smaller bubbles than CO_2 . Afterwards some ales were dispensed in a similar manner. Later, in the UK, small plastic devices called widgets, were put into beer cans along with liquid nitrogen. Nitrogen is not very soluble in beer and diffuses into the cavity in the widget. When the can is opened and the top pressure released, the nitrogen gas within the widget at the bottom of the can forces its way through the beer producing considerable amounts of creamy foam. A warm can may show drastic overfoaming!

Alcohol-free beers usually have unstable foams and additions of small amounts of ethanol (c. 1%) enhances foamability and foam stability but this declines at higher concentrations. Ethanol is weakly surface active but at the concentration in beer (2.3–5.5%, 0.5–1.2 M) it is likely to be challenging foam stability. Lienert (1955) showed that the straight chain higher alcohols, and their acetate esters, all destroy foam, the effect increasing with the length of the carbon chain. But the major potential foam inhibitors in

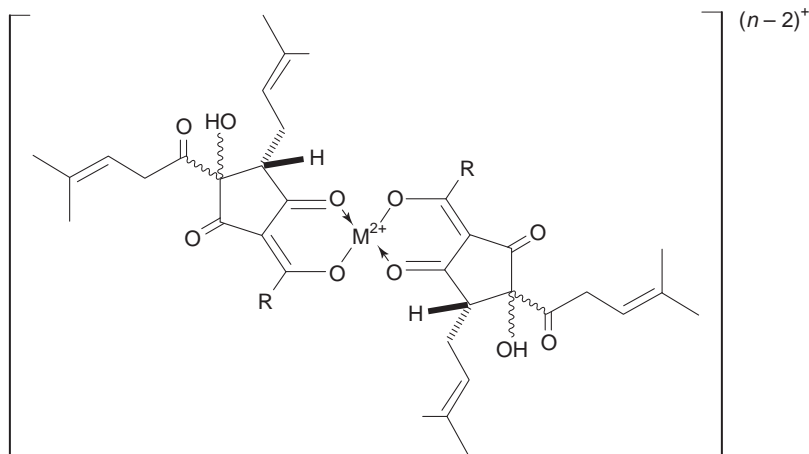

Fig. 19.8 Possible structure of iso- α -acids chelated to a metal cation (Baxter and Hughes, 2001, Fig. 2.2). Reproduced by permission of The Royal Society of Chemistry

beer are lipids (Dickie *et al.*, 2001). Lipids in beer can be either intrinsic, derived from malt and yeast lipids, or extrinsic, derived from dirty glassware, fatty foods or cosmetics. Few of the lipids present in the grist are thought to survive into beer so the intrinsic lipids are likely to be derived from the yeast. For example, a significant negative correlation was found between the HRV and the free fatty acid content of beer. Bamforth and Jackson (1983) found that, in particular, decanoic and dodecanoic acids and unsaturated C_{18} acids disrupted beer lacing. Monopalmitin was more disruptive than dipalmitin and tripalmitin (3 ppm) had a positive effect on lacing. Roberts *et al.* (1978) observed that after the addition of lipid to beer there was a large drop in the HRV but on stirring the beer the HRV recovers approaching the original value. This is thought to be due to the presence of lipid binding proteins in the beer, which have yet to be characterized. Lipid binding proteins have been characterized in wheat (puroindolines) and barley (hordoindolines) (M_r c. 13 kDa) but it is not known whether they survive the brewing process.

19.6.3 Head retention and the brewing process

Dilution experiments show that all-malt worts provide an excess of foam-positive substances so that dilution of the grist with nitrogen-free adjuncts or sugars should not affect the head retention significantly. The use of unmalted cereals such as wheat flour or flaked barley in the grist improves head retention in the beer but maize and rice have to be processed before use to reduce the level of lipid. Brewhouse procedures can also influence the level of lipid in the wort. The last runnings from the mash tun may be rich in malt fat. Strainmasters (Nooter tuns) give worts with high lipid contents but if the mash worts are recycled the level of lipids is reduced (Chapter 6). Hop-boiling improves head retention unless so prolonged that all the foam stabilizing proteins are coagulated. The hop back is more efficient than the hop separator for eliminating lipids.

During the brewing process the largest loss of head retention occurs during fermentation (Table 19.24). This is due to the loss of foam stabilizing material into the foam and yeast crop and to the formation of ethanol, higher alcohols, C_6 – C_{12} fatty acids and other negative foam factors. More foam stabilizing factors are lost on top-fermenting yeasts than bottom-fermenting strains so the choice of yeast strain is important. Foam can

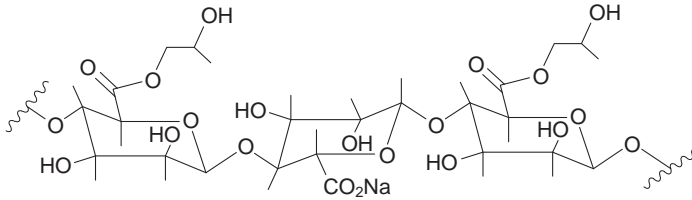

Fig. 19.9 Idealized structure of propylene glycol alginate (Baxter and Hughes, 2001, Fig. 2.5).
Reproduced by permission of the Royal Society of Chemistry.

be controlled by the use of enclosed fermentation vessels and by recycling part of the fermenting wort and using it to sparge the yeast head and foam (Thompson *et al.*, 1965). Yeast should not be allowed to autolyse in contact with the beer as the fatty acids liberated will destroy the foam stability. Fining, by means of isinglass, always improves head retention and the finished beer should always be handled gently. Finally, pipes, taps and glassware used in dispense must be kept scrupulously clean and well rinsed as traces of detergent can reduce head retention.

As mentioned above the brewer can improve head retention by choice of malt rich in protein Z4 and by the addition of wheat flour to the grist. Foam quality can also be improved by the post-fermentation addition of tetrahydroiso- α -acids. Propylene glycol alginate (PGA, Fig. 19.9) is a permitted additive to improve foam stability. It is formed by partial esterification (80–90%) of alginic acid with propylene oxide. Typical levels of application are c. 50 mg/l.

19.7 Gushing

Gushing, wild, overfoaming or jumping beer, as it is variously called, is an undesirable quality in packaged beer (Gardner, 1973). A beer is said to gush when, on releasing the overpressure, innumerable minute bubbles appear throughout the volume of the beer which rapidly expand and displace the contents of the bottle. In severe cases as much as three-quarters of the contents may be lost. Outbreaks of gushing may be of two types: (i) Sporadic or transitory or (ii) Epidemic or serious. Transitory gushing may be related to minor changes in the production process and is usually susceptible to specific cures. Epidemic outbreaks of gushing may affect several breweries in the same area or those using a common source of raw material. Many factors have been implicated in gushing: since it is overfoaming an excess of the materials involved in head formation may be responsible. Simon (1998) thinks that overcarbonation may be responsible for some cases of gushing but other workers say that, although overcarbonation and rough handling may stimulate gushing in sensitive beers, it will not induce it in normal beers. As noted above, beers carbonated with a mixture of carbon dioxide and nitrogen (and a widget) are more likely to gush than those carbonated with CO₂ alone.

Krause (1936) suggested that prolonged shaking beats many microbubbles from the headspace into the beer and these microbubbles attract surface active constituents into their interfaces. When the gas dissolves the hydrophobic surface active shells may not dissolve and remain to act as nuclei for CO₂ evolution. Gardner (1973) has reviewed the evidence in support of Krause's idea but the nature of the nuclei is still not understood. The nuclei have not been observed by electron microscopy and, by this technique, no difference could be seen between precipitates collected from gushing and non-gushing

beers. Turbid beers do not have an increased tendency to gush. A correlation has been found between surface viscosity and gushing. Substances known to promote gushing increase the viscosity which is reduced when antigushing agents are added. A high surface viscosity does not cause gushing but appears to correlate with the existence of stable nuclei.

Transitory outbreaks of gushing have been observed due to the precipitation of microcrystals of calcium oxalate while other outbreaks have been associated with the presence of heavy metals, in particular, iron, nickel, tin and molybdenum. Such outbreaks can often be cured by the addition, if allowed, of EDTA to the beer; EDTA forms complexes with calcium and the heavy metals. Iron and nickel cause gushing only in the presence of iso- α -acids but cobalt shows little tendency to cause gushing. Indeed, in one outbreak of gushing the addition of 0.2–1.0 ppm of cobalt dramatically reduced the incidence of gushing but in another it was without effect. In any case the addition of cobalt causes toxicity problems with heavy drinkers (Long, 1999).

Severe outbreaks of gushing have been associated with the introduction of new season's malt especially when this has been made from barley harvested under wet conditions. Such barleys/malts are often contaminated with moulds especially *Fusarium* spp. Both Narziss *et al.* (1990) and Niessen *et al.* (1992) found that the most common fungal contaminant of barley, associated with gushing, was *F. graminearum*. Other species associated with gushing include *F. avenaceum*, *F. culmorum*, *F. oxysporum*, *Alternaria alternata*, and species of *Penicillium*, *Mucor* and *Rhizopus*. Wheat infected with *Microdochium nivale* var. *major* also produces beverages with gushing properties. Scanning electron spectroscopy showed that with *Fusarium* species the fungal hyphae and mycelia tended to concentrate in the furrow and tip of the grain where they were not readily apparent to the naked eye.

Similarly, in the USA Schwarz *et al.* (1996) found that malt samples infected with *Fusarium* species produced beers with a propensity to gush and that the levels of deoxynivalenol and ergosterol (*Fusarium* metabolites) strongly correlated with the amount of gushing. However, it is thought unlikely that deoxynivalenol and ergosterol promote gushing themselves but, rather, a polypeptide produced from the barley or malt by the micro-organism is the active agent. Obviously it is undesirable to use weathered barley for malting but, if necessary, the addition of formaldehyde to the steep liquor, if allowed, gives malt that does not produce a gushing beer. Other successful treatment of wild beer include the use of absorbents such as kaolin (1,000 g/l), bleaching earth (200 g/l), fullers' earth (200 g/l), and nylon (140 g/l) or to increase the hop rate.

The observation that certain isomerized hop extracts provoked gushing led to a detailed examination of the gushing potential of individual components. The α -acids and hulupones suppressed gushing while the iso- α -acids and the humulinic acids had no influence on gushing behaviour. The most potent gushing agent found among the hop compounds was dehydrated humulinic acid [2-isovaleryl-4-(3-methyl-2-butenylidene)cyclopentane-1,3-dione] (Laws and McGuinness, 1972). This occurred only rarely in isomerized extracts but 25 ppm provoked gushing in most commercial beers. Moir *et al.* (1991) prepared an isomerized extract which produced 38% gushing in beer. The unusual constituents responsible for the gushing activity were dimers of the iso- α -acids formed by the action of oxygen on the iso- α -acids in the presence of iron. Other hop compounds reported to provoke gushing include the *abeo*-iso- α -acids and the hexahydroiso- α -acids. Hop extracts contain variable amounts of fatty acids of which long chain saturated fatty acids promote gushing while unsaturated acids suppress gushing.

19.8 References

- ANDERSON, I. W., MOLZAHN, S. W., ROBERTS, N. B., BELLIA, J. and BIRCHALL, D. (1995) *Proc. 25th Congr. Eur. Brew. Conv. Brussels*, 1995, 543.
- ANDERSON, R. J., CLAPPERTON, J. F., CRABB, D. and HUDSON, J. R. (1975) *J. Inst. Brewing*, **81**, 208.
- ANON (1960) *Which*, p. 167.
- ANON (1967) *Which*, p. 366.
- APPERSON, K., LEIPER, K. A., MCKEOWN, I. P. and BIRCH, D. J. S. (2002) *J. Inst. Brewing*, **108**, 193.
- AULT, R. G., HUDSON, E. J., LINEHAN, A. J. and WOODWARD, J. D. (1967) *J. Inst. Brewing*, **73**, 558.
- ÄYRÄPÄÄ, T., HOLMBERG, J. and SELLMANN-PERSSON, G. (1961) *Proc. 8th Congr. Eur. Brew. Conv. Vienna*, 1961, 286.
- BAKER, C. D. (1989) *J. Inst. Brewing*, **95**, 267.
- BAKER, C. D. and UPPERTON, A. M. (1992) *J. Inst. Brewing*, **98**, 461.
- BAKER, C. W. (1990) *Tech. Quart. MBAA*, **27**, 33.
- BAMFORTH, C. W. (1985) *J. Inst. Brewing*, **91**, 370.
- BAMFORTH, C. W. (1999) *J. Amer. Soc. Brew. Chem.*, **57**, 81.
- BAMFORTH, C. W. (2000) *J. Inst. Brewing*, **106**, 229.
- BAMFORTH, C. W. and JACKSON, G. (1983) *Proc. 18th Congr. Eur. Brew. Conv. London*, 1983, 331.
- BAXTER, E. D. and HUGHES, P. S. (2001) *Beer: Quality, Safety and Nutritional Aspects*. Cambridge, The Royal Society of Chemistry pp. xiv + 138.
- BECH, L. M., VAAG, P., HEINEMANN, B. and BREDDAM, K. (1995) *Proc. 25th Congr. Eur. Brew. Conv. Brussels*, 1995, 561.
- BERNSTEIN, L. and LAUFER, L. (1977) *J. Amer. Soc. Brew. Chem.*, **35**, 21.
- BINNS, F., ENSOR, R. J. and MACPHERSON, A. L. (1978) *J. Sci. Food Agric.*, **29**, 71.
- BISHOP, L. R., WHITEAR, A. L. and INMAN, W. R. (1974) *J. Inst. Brewing*, **80**, 68.
- BLOM, J. (1937) *J. Inst. Brewing*, **43**, 251.
- BOTTOMLEY, R. A. and LINCOLN, G. J. (1958) *J. Inst. Brewing*, **64**, 50, 53.
- BRENNER, M. W., BERNSTEIN, L., BLICK, S. R. and BLENKINSHIP, B. K. (1965) *Proc. A. M. Amer. Soc. Brew. Chem.*, 187.
- BUCKEE, G. K. (1994) *J. Inst. Brewing*, **100**, 57.
- BUCKEE, G. K. (1995) *Ferment*, **8**, 357.
- BUCKEE, G. K. (1997) *J. Inst. Brewing*, **103**, 115.
- BUCKEE, G. K. and MUNDY, A. P. (1994) *J. Inst. Brewing*, **100**, 247.
- BUCKEE, G. K., MORRIS, T. M. and BAILEY, T. P. (1986) *J. Inst. Brewing*, **92**, 475.
- CANALES, A. M., DE BANCKS, N. M. and GARZA, T. L. I. (1970) *Proc. A. M. Amer. Soc. Brew. Chem.*, 75.
- CANAS, B. J., HAVERY, D. C., ROBINSON, L. R., SULLIVAN, M. P., JOE, F. R. and DIACHENKO, G. W. (1989) *J. Assoc. Off. Analyt. Chem.*, **72**, 873.
- CARRINGTON, R., COLLETT, R. C., DUNKIN, I. R. and HALEK, G. (1972) *J. Inst. Brewing*, **78**, 243.
- CERVERA, M. A., NAVARRO, A., MONTORO, R., CATALA, R. and YBÁÑEZ, N. (1989) *J. Assoc. Off. Analyt. Chem.*, **72**, 282.
- CHEN, E. C.-H. and VAN GHELUWE, G. (1979) *J. Amer. Soc. Brew. Chem.*, **37**, 91.
- CLARKSON, S. P., ORMROD, I. H. L. and SHARPE, F. R. (1995) *J. Inst. Brewing*, **101**, 191.
- COOTE, N. and KIRSOP, B. H. (1974) *J. Inst. Brewing*, **80**, 474.
- CORNELL, J. (2002) *J. Amer. Soc. Brew. Chem.*, **60**, 215.
- CURTIS, N. S., CLARK, A. G. and OGGIE, P. J. (1963) *J. Inst. Brewing*, **69**, 30.
- DALE, C. J. (1990) *Ferment*, **3**, 217.
- DALE, C. J. and LYDDIATT, A. (1994) *J. Inst. Brewing*, **100**, 173.
- DALE, C. J. and YOUNG, T. W. (1989a) *J. Inst. Brewing*, **95**, 35.
- DALE, C. J. and YOUNG, T. W. (1989b) *J. Inst. Brewing*, **95**, 89.
- DICKIE, K. H., CANN, C., NORMAN, E. C., BAMFORTH, C. W. and MULLER, R. E. (2001) *J. Amer. Soc. Brew. Chem.*, **59**, 17.
- DIFFOR, D., LIKENS, S. T., REHBERGER, A. J. and BURKHARDT, R. J. (1978) *J. Amer. Soc. Brew. Chem.*, **36**, 63.
- DONHAUSER, S., WAGNER, D. and JACOB, F. (1987) *Monats. für Brauwissenschaft*, **40**, 328.
- DRAWERT, F. and TRESSL, R. (1972) *Tech. Quart. MBAA*, **9**, 72.
- DUPIRE, S. (1999) *J. Inst. Brewing*, **105**, 265.
- ENEVOLDSEN, B. S. and SCHMIDT, F. (1974) *J. Inst. Brewing*, **80**, 520.
- EUROPEAN BREWERY CONVENTION (1999) *Monograph 27. Symposium on Beer Foam Quality, Amsterdam*, October 1998. Nürnberg: Hans Carl, p. 220.
- EVANS, D. E. and HEJGAARD, J. (1999) *J. Inst. Brewing*, **105**, 159.
- EVANS, D. E. and SHEEHAN, M. C. (2002) *J. Amer. Soc. Brew. Chem.*, **60**, 47.
- EVANS, D. E., SHEEHAN, M. C. and STEWART, D. C. (1999) *J. Inst. Brewing*, **105**, 171.
- FARRE, R., GIMENO, M. J. and LAGARDA, M. J. (1987) *J. Inst. Brewing*, **93**, 394.
- FERREIRA, A. A. (2003) *J. Inst. Brewing*, **109**, 400.
- FISHER, S., HAUSER, G. and SOMMER, K. (1999) *Eur. Brew. Conv. Monograph No. 27 Beer Foam Quality, Amsterdam*, p. 37.

- FOOD LABELLING REGULATIONS, THE (1980) SI 1849: 1980. Schedule 5.
- FRESTON, M. J. and BAKER, C. D. (1993) *J. Inst. Brewing*, **99**, 377.
- GARDNER, R. J. (1973) *J. Inst. Brewing*, **79**, 275.
- GJERTSEN, P. (1955) *Proc. 5th Cong. Eur. Brew. Convn.*, Baden-Baden, p. 37.
- GLASER, G. (2002) *Modern Brewery Age*, **53** (12), 6, 32.
- GMELCH, F., MAIER, J., ROSSBAUER, G. ZWACK, F. and NAST, D. (1989) *Brauwelt*, **129** (45), 2156, 2158–2162.
- GREENHOFF, K. and WHEELER, R. E. (1981) *J. Inst. Brewing*, **87**, 35.
- GREENSHIELDS, R. N. (1974) *J. Sci. Food Agric.*, **25**, 1307.
- HARDING, R. J., NURSTEN, H. E. and WREN, J. J. (1977) *J. Sci. Food Agric.*, **28**, 225.
- HARRIS, G. (1965) *J. Inst. Brewing*, **71**, 292.
- HARRISON, G. A. F., BYRNE, W. J. and COLLINS, E. (1965a) *Proc. 10th Congr. Eur. Brew. Convn. Stockholm*, 1965, p. 352.
- HARRISON, G. A. F., BYRNE, W. J. and COLLINS, E. (1965b) *J. Inst. Brewing*, **71**, 336.
- HEGARTY, P. K., PARSONS, R., BAMFORTH, C. W. and MOLZAHN, S. W. (1995) *Proc. 25th Congr. Eur. Brew. Convn. Brussels*, 1995, 515.
- HEJGAARD, J. and KAERSGAARD, P. (1983) *J. Inst. Brewing*, **89**, 402.
- HELM, E. (1933) *Wochensch. Brau.*, **50**, 241.
- HM CUSTOMS AND EXCISE (1997) *Notice 226. Beer Duty* (including Update 1, December 2000)
- HUDSON, J. R. (1955) *J. Inst. Brewing*, **61**, 127.
- HUDSON, J. R. (1969) *J. Inst. Brewing*, **75**, 164.
- HUGHES, P. S. and SIMPSON, W. J. (1995) *Cerevisia Biotechnol.*, **20**, 35.
- HYSERT, D. W., MORRISON, N. M. and JAMIESON, A. M. (1979) *J. Amer. Soc. Brew. Chem.* **37**, 30.
- ILETT, D. S., BURKE, S. and SIMPSON, W. J. (1996) *J. Sci. Food Agric.*, **70**, 337.
- ISHIBASHI, Y., TERANO, Y., FUKUI, N., HONBOU, N., KAKUI, T., KAWASAKI, S. and NAKATANI, K. (1996) *J. Amer. Soc. Brew. Chem.*, **54**, 177.
- ISHIHARA, S. (1964) *Tests for Colour Blindness*, Kanehara, Shuppan, Tokyo, Japan.
- JACKSON, G. and BAMFORTH, C. W. (1982) *J. Inst. Brewing*, **88**, 378.
- JEGOU, S., DOULIEZ, J. P., MOLLE, D., BOIVIN, P. and MARION, D (2000) *J. Agric. Food Chem.*, **48**, 5023.
- JOHNSON, B. A. and JOHANSSON, C.-G. (1999) *J. Inst. Brewing*, **105**, 360.
- JURADO, J. (2001a) *The Brewer International*, **1** (10), 41.
- JURADO, J. (2001b) *The Brewer International*, **1** (12), 39.
- JURADO, J. (2002a) *The Brewer International*, **2** (2), 20.
- JURADO, J. (2002b) *The Brewer International*, **2** (4), 30.
- JURADO, J. (2002c) *The Brewer International*, **2** (6), 29.
- JURADO, J. (2002d) *The Brewer International*, **2** (9), 33.
- JURADO, J. (2002e) *The Brewer International*, **2** (12), 21.
- KAERSGAARD, P. and HEJGAARD, J. (1979) *J. Inst. Brewing*, **85**, 103.
- KALAČ, P. and KRÍŽEK, M. (2003) *J. Inst. Brewing*, **109**, 123.
- KIENINGER, H. (1978) *Brauwelt*, **18**, 616.
- KIENINGER, H. and BIRKOVA, V. (1975) *Brauwelt*, **115**, 1250.
- KLOPPER, W. J. (1973) *Proc. 14th Congr. Eur. Brew. Convn., Salzburg*, p. 363.
- KLOPPER, W. J., ANGELINO, S. A. G. F., TUNING, B. and VERMEIRE, H. A. (1986) *J. Inst. Brewing*, **92**, 225.
- KOIKE, K., HASHIMOTO, N., KITAMI, H. and OKEDA, K. (1972) *Reports of the Research Laboratories of the Kirin Brewery Co. Ltd.*, **15**, 25.
- KONDO, H., YOMO, H., FURUKUBO, S., FUKUI, N., NAKATANI, K. and KAWASAKI, Y. (1999) *J. Inst. Brewing*, **105**, 293.
- KRAUSE, B. (1936) *Svenska Bryggareförenings Månadsblad*, **51**, 221.
- LAWS, D. R. J. and McGUINNESS, J. D. (1972) *J. Inst. Brewing*, **78**, 302.
- LERMUSIEAU, G., BULENS, M. and COLLIN, S. (2001) *J. Agric. Food Chem.*, **49**, 3867.
- LIENERT, H. (1955) *Proc. 5th Congr. Eur. Brew. Convn., Baden-Baden*, p. 282.
- LONG, D. G. (1999) *J. Inst. Brewing*, **105**, 79.
- LUSK, L. T., GOLSTEIN, H. and RYDER, D. (1995) *J. Amer. Soc. Brew. Chem.*, **53**, 93.
- LUSK, L. T., DUNCOMBE, G. R., KAYE, S. B., NAVARRO, A. and RYDER, D. (2001) *J. Amer. Soc. Brew. Chem.*, **59**, 183.
- MACKIE, A. E. and SLAUGHTER, J. C. (2000) *J. Inst. Brewing*, **106**, 209.
- MANDL, B. and PIENDL, A. (1971) *Proc. 13th Congr. Eur. Brew. Convn., Estoril*, p. 343.
- MARTIN, P. A. (1982) *J. Inst. Brewing*, **88**, 320.
- McFARLANE, W. D. and THOMPSON, K. D. (1964) *J. Inst. Brewing*, **70**, 467.
- McMURROUGH, I. (1995) *Ferment*, **8**, 39.
- McMURROUGH, I., MADIGAN, D., DONNELLY, D., HURLEY, J., DOYLE, A. M., HENNIGAN, G., MCNULTY, N. and SMYTHE, M. R. (1996) *J. Inst. Brewing*, **102**, 327.
- MEILGAARD, M. C. (1975) *Tech. Quart. MBAA*, **12**, 151.
- MOIR, M. (1994) *EBC Monograph XXII. Symposium on Hops, Zoeterwoude*, p. 165.
- MOIR, M., DOBSON, G. and SEATON, J. C. (1991) *Proc. 23rd Congr. Eur. Brew. Convn., Lisbon*, p. 225.

- MORGAN, K. (1965) *J. Inst. Brewing*, **71**, 166.
- MORRIS, T. M. (1987) *J. Inst. Brewing*, **93**, 13.
- MUNDY, A. P. (1991) *J. Inst. Brewing*, **97**, 45.
- MUNDY, A. P. (1996) *J. Inst. Brewing*, **102**, 69.
- MUNDY, A. P. and BOLEY, N. (1999) *J. Inst. Brewing*, **105**, 75.
- NARZISS, L. and RÖTTGER, W. (1973) *Brauwissenschaft*, **26**, 261.
- NARZISS, L., MIEDANER, H. and BOURJA, T. (1979) *Brauwissenschaft*, **32**, 62.
- NARZISS, L., BACK, W., REICHENEDER, E., SIMON, A. and GRANDL, R. (1990) *Monatsschrift für Brauwissenschaft*, **43**, 296.
- NIESSEN, L., DONHAUSER, S., WIEDENEDER, A., GEIGER, E. and VOGEL, H. (1992) *Brauwelt*, **132** (16/17), 702.
- OTTER, G. E. and TAYLOR, L. (1967) *J. Inst. Brewing*, **73**, 570.
- OTTER, G. E. and TAYLOR, L. (1971) *J. Inst. Brewing*, **77**, 467.
- OWADES, J. L. and JACEVAC, J. (1959) *Proc. Ann. Meet. Amer. Soc. Brew. Chem.*, p. 18.
- PALAMAND, S. R. and GRIGSBY, J. H. (1974) *Brewers Digest*, Sept. pp. 58, 90.
- PALAMAND, S. R., HARDWICK, W. A. and MARKL, K. S. (1969) *Proc. Ann. Meet. Amer. Soc. Brew. Chem.*, p. 54.
- PAUL, A. A. and SOUTHGATE, D. A. T. (eds) (1978) *McCance and Widowsons' The Composition of Foods*. 4th edn HMSO, London.
- PEPPARD, T. L. (1985) *J. Inst. Brewing*, **91**, 364.
- PEPPARD, T. L. and HALSEY, S. A. (1981) *J. Inst. Brewing*, **87**, 85.
- PEPPARD, T. L. and HALSEY, S. A. (1982) *J. Inst. Brewing*, **88**, 309.
- PERPÊTE, P. and COLLIN, S. (1999) *J. Agric. Food Chem.*, **47**, 2374.
- PORTNO, A. D. (1966) *J. Inst. Brewing*, **72**, 193, 458.
- POSTEL, W. (1976) *Brauwissenschaft*, **29**, 39.
- POSTEL, W., DRAWERT, F. and GÜVENC, U. (1972a) *Brauwissenschaft*, **25**, 341.
- POSTEL, W., DRAWERT, F. and GÜVENC, U. (1972b) *Brauwissenschaft*, **25**, 391.
- POSTEL, W., DRAWERT, F. and GÜVENC, U. (1973) *Brauwissenschaft*, **26**, 46.
- POSTEL, W., DRAWERT, F. and GÜVENC, U. (1974) *Brauwissenschaft*, **27**, 11.
- POSTEL, W., GORG, A. and GÜVENC, U. (1976) *Brauwissenschaft*, **29**, 132.
- POSTEL, W., GORG, A., DRAWERT, F. and GÜVENC, U. (1975) *Brauwissenschaft*, **28**, 301.
- POSTEL, W., MEIER, B. and MARKERT, R. (1983) *Monatsschrift für Brauwissenschaft*, **36**, 360.
- PRINS, A. and MARLE, J. T. (1999) *EBC Monograph 27. Symposium on Beer Foam Quality*, Amsterdam, p. 26.
- QURESHI, A. A., BURGER, W. C. and PRENTICE, N. (1979) *J. Amer. Soc. Brew. Chem.* **37**, 153.
- ROBBERECHT, H., VAN SCHOOR, O. and DEELSTRA, H. (1984) *J. Food Sci.*, **49**, 300.
- ROBERTS, R. T., KEENEY, P. J. and WAINWRIGHT, T. (1978) *J. Inst. Brewing*, **84**, 9.
- RONTELAP, A., HOLLEMANS, M., BISPERINK, C. G. J. and PRINS, A. R. (1991) *Tech. Quart. MBAA*, **28**, 25.
- ROSENDAL, I. AND SCHMIDT, F. (1987) *J. Inst. Brewing*, **93**, 373.
- ROSS, S. and CLARKE, C. L. (1939) *Wallerstein Labs. Commun.*, **6**, 46.
- RUDIN, A. D. (1957) *J. Inst. Brewing*, **62**, 506.
- SADOSKY, P., SCHWATZ, P. B. and HORSLEY, R. D. (2002) *J. Amer. Soc. Brew. Chem.*, **60**, 153.
- SCHROPP, P., BRUDER, T. and FORSTNER, A. (2002) *Monatsschrift für Brauwissenschaft*, **55**, 212.
- SCHWARZ, P. B. and HAN, J.-Y. (1995) *J. Amer. Soc. Brew. Chem.*, **53**, 157.
- SCHWARZ, P. B., BEATTIE, S. and CASPER, H. H. (1996) *J. Inst. Brewing*, **102**, 93.
- SHAH, S. K. (1975) *J. Inst. Brewing*, **81**, 293.
- SHARPE, F. R. (1997) *J. Inst. Brewing*, **103**, 277.
- SHARPE, F. R., GARVEY, T. B. and PYNE, N. S. (1992) *J. Inst. Brewing*, **98**, 321.
- SHEEHAN, M. C. and SKERRITT, J. H. (1997) *J. Inst. Brewing*, **103**, 297.
- SHIMIZU, C., NAKAMURA, Y., MIYAI, K., ARAKI, S., TAKASHIO, M. and SHINOTSUKA, K. (2001) *J. Amer. Soc. Brew. Chem.*, **59**, 51.
- SIEBERT, K. J. (1999) *J. Agric. Food Chem.*, **47**, 353.
- SIEBERT, K. J. and LYNN, P. Y. (1997) *J. Amer. Soc. Brew. Chem.*, **55**, 73.
- SIEBERT, K. J. and LYNN, P. Y. (1998) *J. Amer. Soc. Brew. Chem.*, **56**, 24.
- SIEBERT, K. J., TROUKHANOVA, N. V. and LYNN, P. Y. (1996) *J. Agric. Food Chem.*, **44**, 80.
- SILBEREISEN, K. and BIELIG, K. (1961) *Proc. 8th Congr. Eur. Brew. Convn., Vienna*, p. 421.
- SIMON, R. (1998) *Brauwelt*, **138**, 1244.
- SIMPSON, W. J. and HUGHES, P. S. (1994) *Cerevisia Biotechnol.*, **19** (3), 39.
- SINCLAIR, A., HALL, R. D., THORBURN-BURNS, D. and HAYES, W. P. (1970) *J. Sci. Food Agric.*, **21**, 468.
- SLACK, P. T. and BAMFORTH, C. W. (1983) *J. Inst. Brewing*, **89**, 397.
- SLAUGHTER, J. C. and UVGARD, A. R. A. (1971) *J. Inst. Brewing*, **77**, 446.
- SLAUGHTER, J. C. and UVGARD, A. R. A. (1972) *J. Inst. Brewing*, **78**, 322.
- SMEDLEY, S. M. (1992) *J. Inst. Brewing*, **98**, 497.
- SMEDLEY, S. M. (1995) *J. Inst. Brewing*, **101**, 195.
- SØRENSEN, S. B. and OTTESEN, M. (1978) *Carlsberg Res. Commun.*, **43**, 133.

- THALAKER, R. and KALTWASSER, I. (1978) *Monatsschrift für Brauerei*, **31**, 20.
- THOMPSON, C. C., CURTIS, N. S., GOUGH, P. E. and RALPHM D. J. (1965) *Proc. 10th Congr. Eur. Brew. Conv., Stockholm*, p. 305.
- THORNE, R. S. W. and NANNSTED, I. (1960) *J. Inst. Brewing*, **66**, 388.
- THORPE, E. and BROWN, H. T. (1914) *J. Inst. Brewing*, **20**, 569.
- TRESSL, R., KOSSA, T., RENNER, R. and KÖPPLER, H. (1975) *Monatsschrift für Brauerei*, **28**, 109.
- TRESSL, R., RENNER, R., KOSSA, T. and KÖPPLER, H. (1977) *Proc. 16th Congr. Eur. Brew. Convn., Amsterdam*, p. 693.
- TRESSL, R., FRIESE, L., FENDSACK, F. and KÖPPLER, H. (1978) *J. Agric. Food Chem.*, **26**, 1422.
- VAAG, P., BECH, L. M., CAMERON-MILLS, V. and SVENDSEN, I. (1999) *Proc. 27th Congr. Eur. Brew. Convn., Cannes*, p. 157.
- VAN OEVELEN, D., DE L'ESCAILLE, F. and VERACHTERT, H. (1976) *J. Inst. Brewing*, **82**, 322.
- WARNAKULASURIYA, S., HARRIS, C., GELBIER, S., KEATING, J. and PETERS, T. (2002) *Clin. Chim. Acta*, **320**, 1.
- WEISS, A., SCHÖNBERGER, CH., MITTER, W., BIENDL, M., BACK, W. and KROTTENTHALER, M. (2002) *J. Inst. Brewing*, **108**, 236.
- WHITTLE, N., ELDRIDGE, H., BARTLEY, J. and ORGAN, G. (1999) *J. Inst. Brewing*, **105**, 89.
- WILLIAMS, K. M., FOX, P. and MARSHALL, T. (1995) *J. Inst. Brewing*, **101**, 365.
- YANG, J.-I. and SIEBERT, K. J. (2001) *J. Amer. Soc. Brew. Chem.*, **59**, 172.
- YBÁÑEZ, N., NAVARRO, A. and MONTORO, R. (1989) *J. Inst. Brewing*, **95**, 257.

Beer flavour and sensory assessment

20.1 Introduction

The final arbiter of beer quality is the palate of the consumer and this can show wide variation between individuals, between geographical areas, and even from one time to another. Quality is defined as 'degree of excellence, relative nature, or kind, or character' and accordingly the brewer refers to the many varieties of ale, beer, stout, and lager which he brews to satisfy varied demand as different qualities. When the customer has chosen the quality he wishes to drink he demands that his beverage shall have the 'degree of excellence' which he expects and this shall not change from day to day. Much of the brewers' art is therefore concerned with quality control, with producing a constant product from variable raw materials by a biological process (Hough, 1990). Today the concept of quality assurance is more important whereby each stage is monitored before the next is allowed and the raw materials and any additives can be traced back to their source (see EBC Monograph No. 26 Symposium on Quality Issues & HACCP (Hazard Analysis Critical Control Points), 1997).

The enjoyment of a glass of beer may be received by many senses. Smythe *et al.* (2002) have shown the impact of the appearance of beer on its perception and the parameters discussed in the last chapter: alcoholic content, nutritive value, colour, clarity, usually, the absence of haze, the formation and retention of a good head of foam, and the absence of gushing, all contribute to the enjoyment but it is the flavour, the taste and aroma, which really determine the acceptability and drinkability of the beer. Originally, it was the palate of the head brewer that decided if the beer was acceptable but later this responsibility was transferred to a tasting panel and as tasting panels became more sophisticated the science of sensory analysis came into being (Amerine *et al.*, 1965). *Analytica-EBC* and the ASBC have agreed International methods for sensory analysis and the Institute of Brewing have published a Sensory Analysis Manual (Institute of Brewing, 1995). More recent advances have involved the use of electronic 'noses' or sensors (Torline *et al.*, 1999; Given and Parades, 2002). Doty (1995) has edited a *Handbook of Olfaction and Gustation* and Acree and Teranishi have edited a handbook of *Flavor Science* (1993).

20.2 Flavour – taste and odour

According to the EBC-ASBC definitions, flavour is the combination of olfactory and gustatory attributes perceived during tasting, including tactile, thermal, pain and kinesthetic effects. Kinesthetic sense is the deep pressure sense, or proprioception. Somesthetic sense is the tactile sense, or skin-feel, both are part of the sense of touch. Tactile senses refer more to solid foodstuffs but in beer are related to what is called ‘palate fullness’, ‘body’, or ‘mouth-feel’ (Langstaff and Lewis, 1993). EBC/ASBC define mouth-feel as the tactile sensations perceived at the lining of the mouth, including the tongue and teeth. With regard to beer, taste and odour are the most important aspects of flavour.

Taste is the sensory attribute resulting from stimulation of the gustatory receptors in the oral cavity by certain soluble substances. Two American Chemical Society symposia have discussed taste chemistry (Boudreau, 1979; Given and Parades, 2002) and Breslin (2001) has provided a review. Two types of chemoreceptor are recognized; free nerve endings, which occur throughout the oral cavity, and taste buds. The free nerve endings possess no recognizable receptors and are responsible for the perception of pungency and astringency. Taste buds are neural complexes of 25–50 specialized cells which occur in localized areas of the oral cavity. On the tongue they occur on protuberances called papillae. Four types of papillae are recognized: the filiform papillae have no taste buds and the foliate papillae, which occur in folds on the sides of the back of the tongue, are not well developed in man. More important are the 13–400 mushroom-like fungiform papillae on the tip and sides of the tongue and the 6–15 large (circum)vallate papillae at the back of the tongue (Fig. 20.1) (See Amerine *et al.*, 1965, for microphotographs). Taste buds are pear shaped (40–70 μm) connected to the oral cavity via a narrow pore (2 μm). At the top of the taste bud microvilli (0.1–0.2 μm diam. 1–2 μm long) are situated in the pore and these are probably the first point of contact with the tastants. The taste stimuli apparently do not penetrate the receptor membrane but interact at the outer surface.

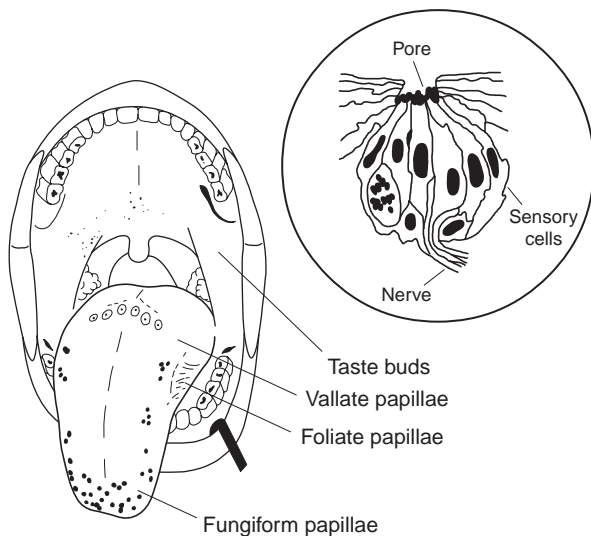

Fig. 20.1 Location of some oral chemosensory receptor systems. Taste buds (schematic, upper right) are found on specialized papillae on the tongue and scattered on the palate and posterior oral structures. Free nerve endings are found on all oral surfaces (After Boudreau, 1979).

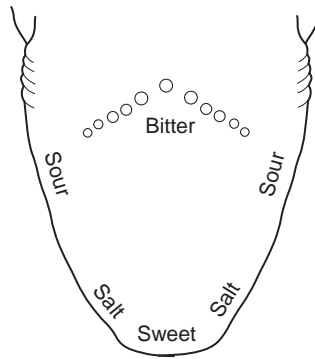

Fig. 20.2 Areas of the human tongue where the four tastes are most easily sensed. All four tastes are perceived, but less readily, over the central area.

The taste cells are secondary receptor cells as they have no axions of their own but are connected by basal synapses to taste fibres running to the central nervous system. Three nerves are involved; the nervus glossopharyngeus (IX) for the back third of the tongue including the circumvallate papillae, the nervus vagus (X) for the throat and the larynx, and the chorda tympani (CT) part of the nervus facialis (VII) for the front two-thirds of the tongue with the fungiform papillae. It is estimated that the circumvallate papillae contain 1,000–1,500 taste buds and the fungiform papillae 300–400 (Van der Heijden, 1993).

Although the four basic tastes, sweet, sour, salt, and bitter are perceived throughout the oral cavity, they are perceived more strongly in specific areas (Fig. 20.2). Inspection of this figure shows that the bitter taste of beer can only be evaluated satisfactorily if the beer is swallowed and allowed to flow over the circumvallate taste buds at the back of the tongue. The sweet taste, perceived by taste buds on the fungiform papillae, has received the most study (Van der Heijden, 1993). The transduction of the sweet taste appears to involve specific membrane receptors and Teeter and Gold (1988) have proposed the transduction pathway shown in Fig. 20.3. Akabas *et al.* (1988) concluded that transduction of bitter taste may occur via a receptor-second messenger mechanism leading to neurotransmitter release and may not involve depolarization-mediated calcium entry. The bitter principle denatonium chloride (Fig. 20.4) is a potent blocker of outward potassium currents in taste cells and causes a second messenger release of Ca^{2+} from intracellular stores in a subset of taste cells.

Many substances are known to taste bitter (Rouseff, 1990) and in view of their diverse structures (Fig. 20.4) Delwiche *et al.* (2001) have proposed there must be multiple receptor/transduction mechanisms. They found that the ratings and rankings of 26 subjects placed bitter substances in two general clusters: (i) urea, phenylalanine, tryptophan, and epicatechin, and (ii) quinine (20.1), caffeine (20.2), sucrose octa-acetate (20.3), denatonium benzoate (20.5), tetralone[®] (tetrahydroiso- α -acids, 8.47) and magnesium sulphate. Neither of these groups included propylthiouracil (PROP) (20.4) to which tasters show wide variations in sensitivity. Approximately 25% of tasters find this antithyroid drug extremely bitter ('supertasters'), 50% find it bitter ('tasters') but 25% are non-tasters. It is thought that 'supertasters' perceive all tastes, not just bitterness, more intensely. In 'supertasters' the fungiform papillae on the tongue are denser ($> 35/38.5 \text{ mm}^2$) compared with an average of $15\text{--}35/38.5 \text{ mm}^2$; non-tasters have < 15 papillae/ 38.5 mm^2 . Thirty-five per cent of women are born supertasters compared with 15% of

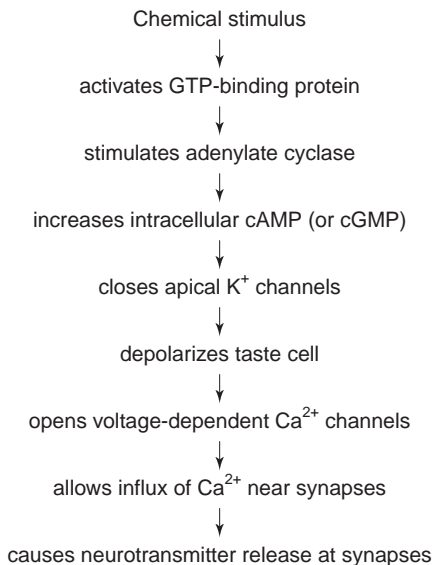
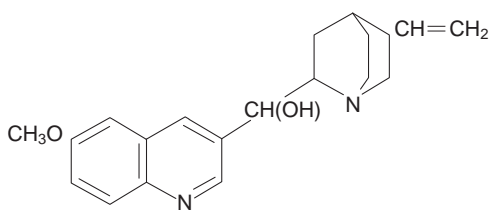
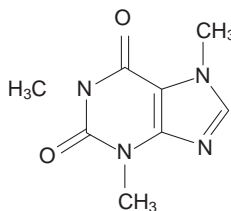

Fig. 20.3 Transduction pathway for the sweet taste (Teeter and Gold, 1988).



(20.1) Quinine



(20.2) Caffeine

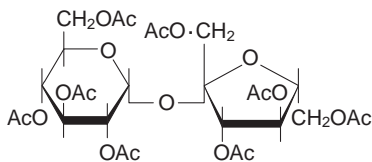

(20.3) Sucrose octaacetate

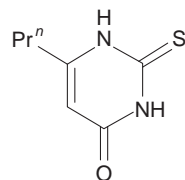

(20.4) Propylthiouracil

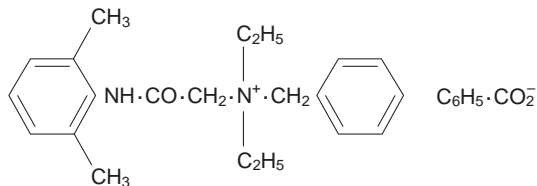

(20.5) Denatonium benzoate

Fig. 20.4 Bitter compounds.

men (Goode, 2003). Delwiche *et al.* (2001) found that although PROP sensitive and PROP insensitive tasters rated the above chemicals differently, they ranked them in a similar order. Montmayeur and Matsunami (2002) have discussed receptors for bitter and sweet tastes. The concentration-response curve for most tastant-receptor reactions is sigmoid in shape (Breslin, 2001).

Other basic tastes include salty which is produced by relatively high concentrations of inorganic ions, in particular Na^+ , K^+ , and Li^+ , on the fungiform papillae but it is seldom a dominant taste in beer. The sour taste is evoked by various Bronsted acids mainly on the foliate papillae on the sides of the tongue. In most beers it is regarded as an off-flavour but is an important character in some Belgian beers produced by spontaneous fermentation. Pleasant is associated with the small fibre geniculate ganglion system and is evoked by lactones and similar carbon-oxygen compounds. 'Umani' is a Japanese word (meaning 'deliciousness') used to describe the sensation elicited by the amino acid monosodium glutamate and the nucleotides sodium inosinate and sodium guanylate. The metallic sensation is produced by certain salts such as silver nitrate and by oct-1-en-3-one. As mentioned above pungency and astringency are sensations produced at the free nerve endings.

Odour is more complicated than taste (see, for example, Ohloff, 1994). Orthonasal olfaction occurs when an odour is sniffed through the nostrils into the nasal cavity where the receptors are located on the olfactory epithelium in the upper respiratory passages (Fig. 20.5). In man the olfactory epithelium occupies 2–4 cm² and contains about 9 million neurons; it is more extensive in other animals. The axions from these cells, many of which cannot be seen with a light microscope, are grouped together in bundles and pass through the cribiform plate into the olfactory bulb, where they terminate in small bodies known as glomeruli. From the glomeruli, mitral cells pass directly into the olfactory lobe of the brain. No other stimuli are received by the brain in such a direct manner. Retronasal olfaction occurs when odours released during eating or drinking are forced behind the palate into the nasal cavity. However, it is likely that the two forms of olfactory input are analysed in different parts of the brain. In beer, and other beverages and foodstuffs, the strength of the odour impression is partly governed by the volatility of the molecules from water, i.e., by the air-water partition coefficient.

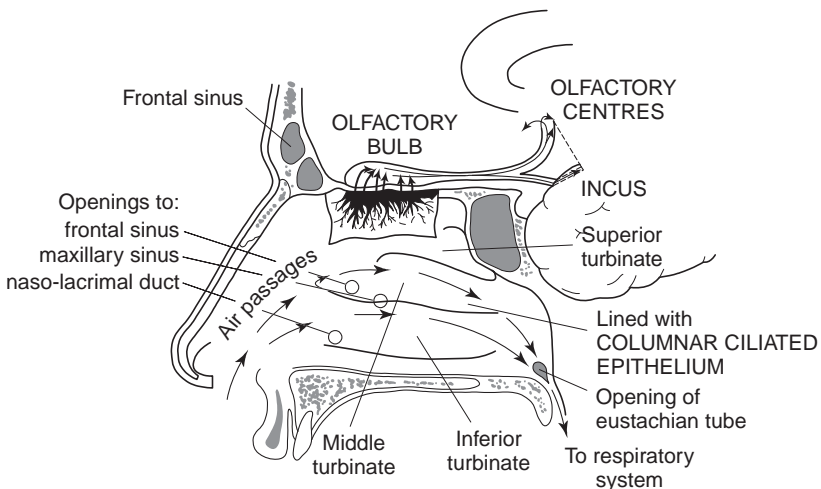

Fig. 20.5 Vertical section of the nasal region of the head.

Table 20.1 Olfactometric properties of eight primary odourants (Amoore, 1991)

Primary odourant	Primary odour	Normal threshold		Anosmic occurrence (%)	Anosmic defect factor
		In air $\mu\text{l/l}$ (v/v)	In water mg/l (w/v)		
Isovaleric acid	Sweaty	0.0010	0.12	3	42
1-Pyrroline	Spermous	0.0018	0.020	16	39
Trimethylamine	Fishy	0.0010	0.00047	6	830
Isobutyraldehyde	Malty	0.0050	0.0018	36	340
5 α -Androst-16-en-3-one	Urinous	0.00019	0.00018	47	770
ω -Pentadecalactone	Musky	0.018	0.0018	12	13
l-Carvone	Minty	0.0056	0.04	8	13
1,8-Cineole	Camphorous	0.011	0.020	33	56

It is thought that the odour perceived is made up from a number of primary odours. Many of these primary odours have been detected from persons with specific anosmias, 'smell blindness' which is the olfactory analogue of colour blindness (Amoore, 1991). In the examples studied so far 3–47% of the population have shown specific anosmia for some compound. Conversely, some people exhibit hyperosmia, when their sensitivity to certain odours may be 1,000-fold greater than normal. Thirty-six per cent of a population had a specific anosmia for the malty isobutyraldehyde. These people could still detect isobutyraldehyde after 16 twofold dilution steps whereas the normal population could detect this compound after 24 dilution steps (a 500-fold deficit of sensitivity for the anosmics). When the same panels investigated isobutyl alcohol there was some overlap between the panels and the anosmic defect was only 4.1 steps. In contrast with isobutyl isobutyrate, the thresholds of the two groups overlapped. Eight primary odorants, which have been examined in this way, are listed in Table 20.1 but 76 compounds have been observed for which specific anosmia has been reported. Several systems of odour classification have been proposed containing 4–44 classes and these have been reviewed by Amoore (1991) together with specific anosmia analyses. Goodenough (1998) has reviewed the molecular biology of olfactory perception.

Taste and odour can be perceived separately but more often than not the two senses are integrated to produce the sensation of flavour. The measurement of taste, odour, or flavour intensity is the subject of at least two different approaches which use different mathematics (Meilgaard, 1975). Those working with strong flavours are concerned with suprathreshold effects and describe the perceived intensity R as a power factor n of the concentration S so that:

$$R = \text{constant} \times S^n$$

For example, with butanol in air the equation becomes:

$$R = 0.261 \times S^{0.66}$$

On the other hand those working with more delicate flavours such as food, vegetables, whisky, wine and beer have assumed that the perceived intensity R is proportional to the concentration S and inversely proportional to the threshold concentration T so that:

$$R = (\text{constant}) \times S/T$$

The power factor n is assumed to be 1.00 and the constant is often omitted so that R is measured as S/T . This ratio has been given different names including 'flavour units' (see p. 285) (Meilgaard, 1975). The power function n in the equation:

$$R = (S/T)^n$$

has been estimated for ethanol ($n = 1.54$), dimethyl sulphide ($n = 1.12$), diacetyl ($n = 0.89$) and isoamyl acetate ($n = 0.82$) (Meilgaard and Reid, 1979). Thus, except for ethanol, the error in assuming $n = 1.00$ is less than 12%.

The EBC/ASBC define four different types of threshold and the term should not be used without qualification:

1. Detection threshold (stimulus threshold, absolute threshold). The minimum value of a sensory stimulus needed to give rise to a sensation.
2. Difference threshold (just noticeable difference). Value of the smallest perceptible change in the physical intensity of a stimulus.
3. Recognition threshold. The minimum value of a sensory stimulus permitting identification of the sensation received.
4. Terminal threshold. Maximum value of a sensory stimulus permitting identification of the sensation perceived.

Usually detection thresholds are lower than recognition thresholds but the literature does not always indicate which is being measured especially when the assessors know the identity of the test substance. When substances are added to beer we are concerned with difference thresholds but many of the methods used for estimation involve recognition of the odd sample. In practice, with trained assessors the difference between difference and recognition thresholds is negligible (Brown *et al.*, 1978). Threshold values are subject to considerable biological variation and it is therefore desirable to include statistical limits in any estimation. Criteria which have been used in estimating thresholds include (Brown *et al.*, 1978):

1. The concentration that can just be perceived by 50% of the population.
2. The geometric mean of the individual thresholds (maximum likelihood threshold).
3. The lowest concentration that can be detected with a ** statistical significance ($P = 0.01$).
4. The concentration producing 50% correct choices (ASTM). Since in paired sample tests 50% correct choices can occur by chance alone, this may be amended to:
5. That concentration producing a frequency of 50% correct above chance.

Many factors influence the measurement of thresholds. For example, the influence of temperature on taste is not uniform and the buffering action of saliva (pH 7.0) may influence perception. The mode of presentation of the sample is also important; thus the average sensitivity threshold for sodium chloride varied from 0.135% for three drops placed on the tongue to 0.047% for 10 ml swallowed and 0.016% when unlimited amounts of the salt solution and distilled water could be compared (Richter and Maclean, 1939). Similarly, repeated practice appears to lower the threshold at which tastes can be perceived. The following thresholds (percentages) were for the first and sixth determinations: sucrose, 0.753, 0.274; caffeine, 0.0272, 0.0078; citric acid, 0.0223, 0.00096; and sodium chloride, 0.123, 0.047 (Pangborn, 1959).

There can be large differences in sensitivity from person to person. For the addition of dimethyl sulphide to beer, tasted by an international panel of 44 persons, 37 panellists (85%) had thresholds in the range of 12–87 $\mu\text{g/l}$, but the remaining seven panellists were much less sensitive and had thresholds in the range 150–2000 $\mu\text{g/l}$ (Brown *et al.*, 1978). Similar results were obtained with diacetyl; with a panel of 16 assessors the geometric mean threshold was 0.080 mg/l but one assessor had a threshold of 2.26 mg/l (Meilgaard

Table 20.2 Detection thresholds for various common taste substances (after Breslin, 2001)

Sensation	Compound	[M]	mg/l
Bitter	Caffeine	5×10^{-4}	97
	Magnesium Sulphate	3.85×10^{-4}	46.35
	Quinine hydrochloride	1.4×10^{-6}	0.505
	Sucrose octa-acetate	3.58×10^{-6}	2.43
	Urea	$(1.07-1.72) \times 10^{-2}$	642-1033
	PROP (taster)	2×10^{-5}	4.04
	PROP (nontaster)	6×10^{-4}	121.2
Salty	NH ₄ Cl	8.39×10^{-4}	44.89
	CaCl ₂	8×10^{-6}	0.888
	LiCl	$(0.9-4) \times 10^{-2}$	381-1696
	NaCl	1.02×10^{-3}	59.62
	KCl	$(6.31-6.49) \times 10^{-3}$	470-484
	Monosodium glutamate	5×10^{-4}	84.5
	L-Arginine	1.23×10^{-3}	214.3
	L-Glutamine	9.77×10^{-3}	1428
Sweet	Aspartame	$(1.76-2.08) \times 10^{-5}$	5.17-6.12
	Fructose	8.9×10^{-4}	160
	Glucose	7.33×10^{-3}	1321
	Glycine	3.09×10^{-2}	2317
	Saccharin Na	$(8.58-10.1) \times 10^{-6}$	1.76-2.07
	Sucrose	6.5×10^{-4}	222.5
Sour	Acetic acid	$(1.07-1.12) \times 10^{-4}$	6.43-6.73
	Citric acid	7×10^{-5}	13.45
	Hydrochloric acid	1.6×10^{-4}	5.84
	Malic acid	7.3×10^{-5}	9.79
	Tartaric acid	4.78×10^{-5}	7.17

PROP = Propylthiouracil

and Reid, 1979). Thus, when measuring thresholds it is desirable to have a panel of at least 25 persons and to calculate individual thresholds so that insensitive persons do not over-influence the group result (Meilgaard and Reid, 1979; Brown *et al.*, 1978). Analytica-EBC/ASBC give methods to determine the threshold of an added substance by the ascending method of limits (see later).

Detection thresholds for representative compounds are collected in Table 20.2. Other values are given by Meilgaard (1975) and some can be found in the Tables in Chapter 19. Quinine (20.1) is often considered the standard bitter taste and is the most bitter compound listed in Table 20.1 but denatonium salts are more bitter. Quinine tonic water contains 56 mg/l (0.5 grain/pint) of quinine sulphate together with sugar (45 g/l) and/or permitted artificial sweetening agents. Caffeine (20.2) is much less bitter and is found in proprietary soft drinks such as Coca-Cola and Lucozade as well as tea and coffee. Magnesium sulphate has similar bitterness to caffeine and it is noteworthy that with propylthiouracil (20.4) the threshold for tasters is 30 times less than that for non-tasters. Sodium chloride has the characteristic salty taste above 0.05 M, but weaker solutions taste sweet. Potassium chloride also tastes sweet in dilute solutions and salty above 0.05 M but between 0.02 M and 0.03 M only bitterness is perceived and this note persists at higher concentration. Calcium chloride has the lowest threshold amongst the salts quoted. The artificial sweeteners aspartame and saccharin have much lower thresholds than the natural sugars. The relative sweetness of a number of other sugars is given in Table 20.3.

Table 20.3 Relative sweetness of sugars (Nieman, 1960)

Lactose	39
Maltose	46
D-Xylose	67
α,β -D-Glucose	69
Glycerol	79
Invert sugar	95
Sucrose	100
Fructose	114
Calcium cyclamate	3,380
Saccharin	30,000

With mineral acids, such as hydrochloric acid, the sourness is proportional to the hydrogen ion concentration but this is not the case with organic acids that are largely undissociated. At equimolecular concentration, hydrochloric acid tastes more sour than acetic acid but at the same pH, acetic acid tastes sourer than the mineral acid. Presumably, as the H^+ of the dissociated acetic acid reacts with the taste receptor, some of the undissociated acid ionizes to restore the equilibrium.

Reviewing the primary tastes in beer its sourness will be measured either as its pH (3.8–4.7) or as its titratable acidity. The level of acetic acid reported for normal beers (57–145 ppm) is below the taste threshold and the same is true for lactic acid (Table 19.7). Infection of beer with micro-organisms such as *Acetobacter* spp. or *Lactobacillus* spp. may reduce the pH and produce a sour taste. Thus with lambic and gueuze beer the pH may drop to 3.2. The level of acetic acid in these beers is 2.6–6.9 times the taste threshold and the level of lactic acid is 5.8–8.6 times the taste threshold (Van Oevelen *et al.*, 1976). Comparison of the level of the inorganic constituents of beer (Table 19.2) with the thresholds give in Table 20.2 suggests that the thresholds of potassium chloride, sodium chloride, calcium chloride and magnesium sulphate could be exceeded, but beers are rarely classed as salty. Similarly, the levels of fructose and glucose in the primed beers 2–4 in Table 19.5 exceed the taste thresholds and the level of glucose in the ale (sample 10) and the lagers (samples 13 and 14) exceeds the threshold. A comparable threshold for maltose is not available; that quoted (1.36%) well exceeds the concentrations of maltose in the beers mentioned in Table 19.5 but, if the comparable threshold was similar to that of lactose (0.16%), as suggested in Table 20.3, the level of maltose in beers no. 1, 5, 6, 13, and 15 would exceed the threshold and influence the taste.

The taste threshold for isohumulone (**8.40**) is reported to be 5.6 mg/l (1.5×10^{-5} M) and that of hulupone (**8.85**) 7.7 mg/l (2.3×10^{-5} M) (Gienapp and Schröder, 1975). Similarly, Weiss *et al.* (2002) found the best estimated threshold for the dicyclohexylamine salt of *trans*-iso- α -acids (66.6% iso- α -acids) in tap water was 4.54 mg/l (1.25×10^{-5} M). Thus, with one exception, the level of iso- α -acids (bitterness units) in all the beers analysed in Table 19.1 exceeds the taste threshold, in the extreme case by 17 times. However, the level of hulupones reported (1.1–4.3 mg/l) does not exceed the threshold. By traditional scaling methods quinine hydrochloride was some six times more bitter than an iso- α -acids preparation which, in turn, was about ten times more bitter than caffeine (Lewis *et al.*, 1980). The character of the bitterness of these compounds is also different; iso- α -acids especially, and quinine to a minor extent, were perceived as a lingering bitterness on the back of the throat while caffeine gives a short-lived bitterness on the tongue.

Weiss *et al.* (2002) also found the best estimated threshold for tetrahydroiso- α -acids (**8.47**) in tapwater was 1.61 mg/l (4.3×10^{-6} M) but in unhopped beer was 8.50 mg/l ($2.32 \times$

10^{-5}M). Similarly, the best estimated threshold for the rho-iso- α -acids (**8.49**) was 6.03 mg/l ($1.65 \times 10^{-5}\text{M}$) in tap water and 11.22 mg/l ($3.03 \times 10^{-5}\text{M}$) in commercial beer in agreement with Table 8.3. These values show the ability of beer to mask bitterness.

The levels of glutamic acid (Tables 9.3 and 19.12) do not exceed the taste threshold given in Table 20.2 and the levels of 5'-inosine monophosphate and 5'-guanosine monophosphate (Table 19.13) in beer are below the taste thresholds but these compounds are reported to be flavour modifiers rather than primary flavours. Additions of 5'-guanosine monophosphate do modify beer flavour but the lowest level of addition of 5'-GMP required to alter beer flavour is greatly in excess of the amount naturally present (Clapperton, 1974).

Despite their widespread adoption the use of thresholds to give flavour units has been criticized: 'Thresholds are but one point on dynamic concentration continuum' (Pangborn, 1980). There is no evidence that intensity/concentration curves for all substances are parallel differing only in the point where they cross the abscissa. Further, taste is not a single instantaneous sensation but has a temporal element. Tasters have been trained to record the intensity on a scale between 0 (none) and 100 (extreme) on a moving recorder chart whereby time-intensity curves such as Fig. 20.6 are obtained (Lewis *et al.*, 1980). Normally the sample is held in the mouth for 10 seconds and then expectorated or, if beer, swallowed. As would be expected when a sucrose gelatine was expectorated the intensity of the sweet sensation immediately started to fall and declined to zero in about 10 s. In contrast, when a sample of beer was swallowed the intensity of the bitterness continued to rise for a further 8 s before starting to fall (Fig. 20.6).

The bitter sensation appears to persist longer (60–90 s) than the sweet sensation. Hughes and Bolshaw (1995) compared the time-intensity curves for *trans*-isohumulone, and preparations of dihydro-, tetrahydro-, and hexahydro-iso- α -acids (Fig. 20.7). The two tasters ranked the compounds in the same order; tetrahydroiso- α -acids, hexahydroiso- α -acids, *trans*-isohumulone, and dihydroiso- α -acids, but the shape of the curves was different. Taster B found the tetrahydroiso- α -acids much more bitter than the other compounds and the aftertaste persisted for over three minutes.

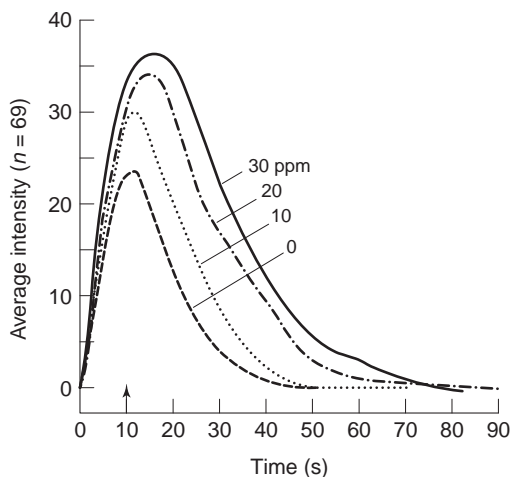

Fig. 20.6 Average time-intensity curve for bitterness of four levels of iso- α -acids in commercial lager. Samples were placed on the mouth at zero times and swallowed at 10 s. The judge continued to record intensity of bitterness until disappearance or for a maximum of two minutes. (after Lewis *et al.*, 1980).

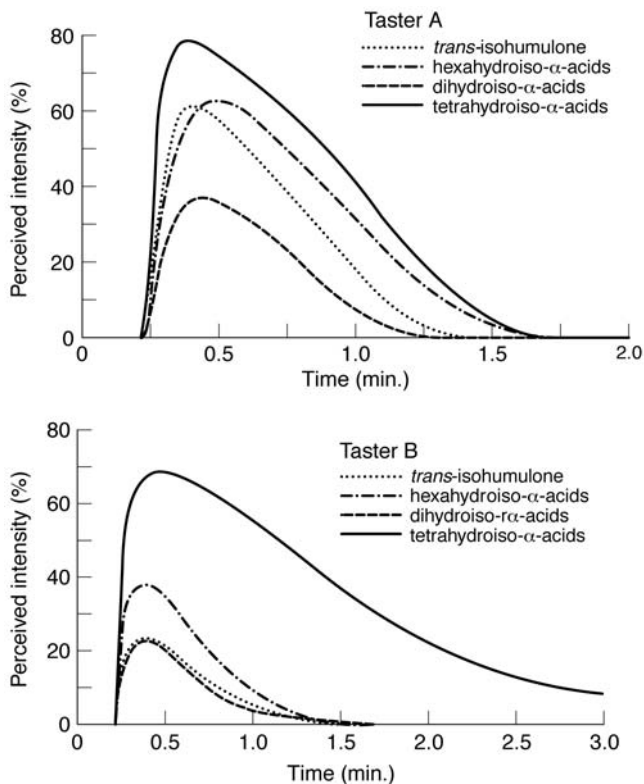

Fig. 20.7 Mean time-intensity curves of *trans*-isohumulone and mixtures of the chemically modified hop bitter acids. Samples were tested in 10 mM sodium phosphate buffer (pH4.15) with 0.05% (v/v) ethanol in black opaque glasses under red light. The solutions were 33.1 μM with respect to the hop bitter acid (Hughes and Bolshaw, 1995).

In general the olfactory threshold of a compound is several orders lower than the taste threshold (Table 20.4). This may represent the probability of a compound taken into the mouth reaching the olfactory epithelium. In a triangular test (see later) the assessors may be required to distinguish the similar beers first on the basis of odour. Indeed with one brewery taste panel it was found that most members differentiated between two beers on the basis of aroma rather than taste 90–95% of the time (Hoff *et al.*, 1978). The olfactory threshold (OT) can be calculated from the simplified equation:

$$\log(\text{OT}) = -\log K_{L/A} - 0.1A_o + (22.13 \pm 0.5)$$

where $K_{L/A}$ is the absorption constant for molecules passing from air to the aqueous-lipid interface (usually between 6.0 and 8.5) and A_o is the cross-sectional area of the molecule (usually between 10–60 \AA^2). Thus the olfactory threshold of a pure compound can be calculated to the first approximation from the partial pressure of the compound above an aqueous solution of the compound, its partition coefficient between water and light petroleum or octanol (substituting for the lipid membrane), and its cross-sectional area, which can be calculated from models.

For a molecule to elicit a flavour it must reach and react with a specific receptor and to do so it will probably have to pass through a lipid membrane, thus the lipophilicity of the molecule will govern this approach. Gardner (1979) showed highly significant

Table 20.4 Odour and taste thresholds of various compounds

	Odour threshold in water (ppb) (Guadagni, 1970)	Taste threshold in beer (ppb) (Meilgaard, 1975)
Ethanol	100,000	14,000,000
Butyric acid	250	2,000
Nootkatone	170	-
Humulene	160	-
Butanal	70	1 000
Myrcene	15	-
<i>n</i> -Amyl acetate	5	5,000
Dimethyl sulphide	0.3	50
<i>n</i> -Decanal	0.1	6
Methyl mercaptan	0.02	2.0
β -Ionone	0.007	1.3
2-Methoxy-3-isobutylpyrazine	0.002	-

correlations between taste threshold and lipophilicity. Thus for a homologous series of compounds (alcohols, esters, ketones, aldehydes and acids) in beers:

$$\log(1/T) = \alpha \log(P) + b$$

where T = threshold in mol/l and P = octanol/water partition coefficient representing lipophilicity. This relationship breaks down when P is greater than 3.0. Similarly, in many series of compounds with bitter taste, the bitterness increases with increasing lipophilicity (Gardner, 1978). Accordingly, Kaneda *et al.* (2001, 2003) found that the absorption/desorption of beer on to a lipid coated quartz crystal microbalance was related to the sensory bitterness. When a molecule has reached a receptor whether or not it initiates a signal to the brain depends upon its size, shape, degree of ionization and charge pattern etc. The size and shape of molecules have also been expressed in terms of molecular connectivity (Kier and Hall, 1976).

On the basis of threshold values and flavour units (FU), Meilgaard (1975) outlined the flavour chemistry of beer as illustrated in Table 20.5. Removal of any of the primary flavour constituents would produce a decisive change in flavour. Later work has not confirmed the importance of humuladienone in the hop aroma compounds but Goiris *et al.* (2002) have confirmed that an oxygenated sesquiterpenoid fraction is responsible for the spicy hop character of beer. Mackie and Slaughter (2002) have shown the importance of 2,5-dimethyl-4-hydroxy-3(2H)-furanone and related compounds among the caramel-flavoured compounds. Removal of any one of the secondary constituents will produce a small change in flavour. Together the secondary flavour constituents form the bulk of a beer's flavour. Any differences between one beer and another of the same type is mostly determined by variations in this class. Tertiary flavour constituents add subsidiary flavour notes. Removal of any one of this class produces no perceptible change in flavour. Similarly it is not possible to say whether the numerous compounds, which individually contribute less than 0.1 FU to the background flavour, are together of importance in beer flavour.

Consideration of the concentration and threshold data in Table 19.8 will show which alcohols, acids and esters may contribute over 2 FU in special beers and between 0.5 and 2.0 FU in regular beers. Octanoic acid (difference threshold, 4.5 mg/l), decanoic acid (1.5 mg/l), dodecanoic acid (0.5 mg/l), and to a lesser extent hexanoic acid contribute to the *caprylic* (goaty) flavour in beer (Clapperton, 1978). The effect of the acids is additive

Table 20.5 Tentative scheme for role of constituents in determining the flavour of beer (Meilgaard, 1975)

1. <i>Primary flavour constituents</i> (above 2 FU*)
Ethanol
Hop bitter compounds (e.g., isohumulone)
Carbon dioxide
<i>Speciality beers</i>
Hop aroma compounds (e.g., humuladienone)
Caramel-flavoured compounds
Several esters and alcohols (high gravity beers)
Short-chain acids
<i>Defective beers</i>
2- <i>trans</i> -Nonenal (oxidized, stale)
Diacetyl and 2,3-pentanedione (fermentation)
Hydrogen sulphide, dimethyl sulphide and other compounds (fermentation)
Acetic acid (fermentation)
2-Methylbut-2-enylthiol (light struck-hops)
Others (microbial infection etc.)
2. <i>Secondary flavour constituents</i> (0.5–2.0 FU)
<i>Volatiles</i>
Banana esters (e.g., isoamyl acetate)
Apple esters (e.g., ethyl hexanoate)
Fusel alcohols (e.g., isoamyl alcohol)
C ₆ , C ₈ , C ₁₀ aliphatic acids
Ethyl acetate
Butyric and isovaleric acids
Phenylacetic acid
<i>Non-volatiles</i>
Polyphenols
Various acids, sugars, hop compounds
3. <i>Tertiary flavour constituents</i> (0.1–0.5 FU)
2-Phenethyl acetate, <i>o</i> -aminoacetophenone
Isovaleraldehyde, methional, acetoin
4-Ethylguaiaicol, <i>gamma</i> -valerolactone
4. <i>Background flavour constituents</i> (below 0.1 FU)
Remaining flavour compounds

* Flavour Units (FU) = concentration/threshold

and there is a linear relationship between the panel score for *caprylic* flavour and concentration of octanoic + decanoic acids. During fermentation lager yeasts produce larger amounts of these acids than ale yeasts. Thus the *caprylic* flavour was observed in most of the lagers and 25% of the ales examined (Clapperton and Brown, 1978).

20.3 Flavour stability

Beer flavour is not static but in a continual state of change. The point where maturation ends and deterioration begins is undoubtedly different for different beers and probably different for different consumers. The off-flavour in one beer may be an essential

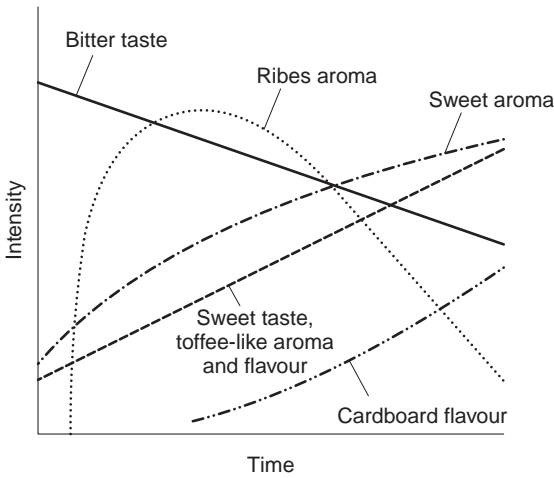

Fig. 20.8 Diagrammatic representation of sensory changes in beer flavour during ageing (Dalglish, 1977).

character of another. Flavour stability has been reviewed by Dalglish (1977) and Tressl *et al.* (1980) have reviewed off-flavours. Since brewers can now largely control biological instability and non-biological haze, it is probably flavour instability that determines the shelf-life of the product. Some of the changes in flavour that occur during beer ageing are illustrated in Fig. 20.8.

Many of the chemical changes during storage involve oxidation and will be accelerated if the beer is allowed to come in contact with oxygen after it leaves the fermentation vessel. The various electronic states of oxygen are illustrated in Fig. 20.9 (Lacan *et al.*, 2000). The ground state is a diradical with two unpaired electrons (having the same spin) in two π^* antibonding orbitals and is comparatively unreactive. Photoexcitation of the ground state gives 'singlet oxygen' (with two electrons of opposite spin) but reduction gives a superoxide radical ion ($\text{O}_2^{\cdot-}$). This superoxide can be formed biochemically from oxygen by reactions involving ubiquinones, catecholamines or thiols and is normally converted to hydrogen peroxide (H_2O_2) by the enzyme superoxide dimutase (SOD). However, in acidic media it forms the hydroperoxy radical ($\text{HOO}\bullet$) which spontaneously disproportionates into hydrogen peroxide and oxygen. In the cell hydrogen peroxide is usually destroyed by the enzyme catalase but it can lead to even more 'reactive oxygen species' (ROS), notably the hydroxy radical ($\text{HO}\bullet$). Thus, hydrogen peroxide can react with superoxide (Haber-Weiss reaction) or with ferrous ions (Fenton reaction) (Fig. 20.10) The hydroxyl radical is probably responsible for initiating the autoxidation of lipids and the role of the Fenton reaction shows the importance of traces of heavy metals on beer deterioration. Kaneda *et al.* (1992) using electron spin

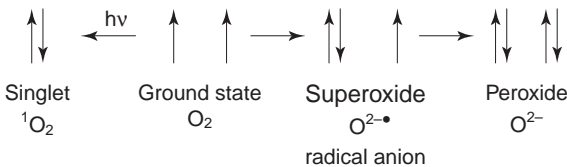
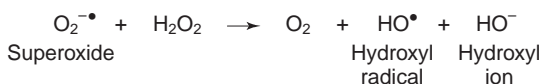
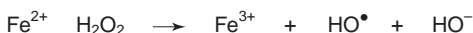

Fig. 20.9 Electronic configurations of various oxygen species (Lacan *et al.*, 2000).

Haber-Weiss reaction



Fenton's reaction

**Fig. 20.10** Production of the hydroxyl radical.

resonance (ESR) showed that the signal due to non-heme Fe^{3+} increased during beer storage. After the addition of potassium hydroxide another signal in the ESR spectrum indicated the presence of free radicals but the half-life of the hydroxy radical is reported as only 10^{-9} s. Uchida and Ono (1999) measured the increase in level of hydrogen peroxide in beer and found it paralleled the formation of hydroxy radicals.

Unsaturated fatty acids, either free or esterified, are particularly susceptible to autoxidation. Compared with oleic acid (*cis*-octadec-9-enoic acid), linoleic acid (**20.6**, *cis, cis*-octadeca-9, 12-dienoic acid) reacts with oxygen 12 times faster and linolenic acid (*cis, cis, cis*-octadeca-9, 12, 15-trienoic acid) reacts 25 times faster.

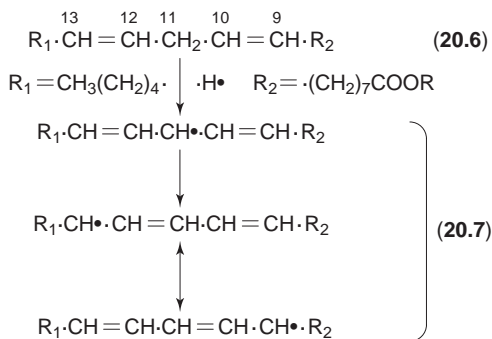

Autoxidation involves abstraction of a hydrogen radical from a carbon atom adjacent to a double bond, e.g., positions 8 and 11 in oleic acid and, particularly, position 11, between two double bonds, in linoleic acid (**20.6**). This forms a mesomeric radical (**20.7**) which then reacts with oxygen to form a mixture of hydroperoxy radicals (ROO^{\bullet}) which abstract another proton to form hydroperoxides (ROOH), e.g. (**20.8**) and (**20.9**). Thus, with linoleic acid, hydroperoxides at positions 9 and 13 predominate. Double bonds that migrate usually adopt *trans*-geometry. Reduction of the hydroperoxide gives a hydroxyl group when hydroxylation of the double bonds gives isomers of trihydroxyoctadecenoic acids (Table 19.7). These acids are the precursor of *trans*-2-nonenal, which is responsible for the cardboard flavour in stale beer (Lermusieau *et al.*, 1999; Noël *et al.*, 1999). It appears that this compound is not formed from oxygen in the head space of bottled beer but during wort preparation when it is bound, for example by proteins or sulphites, and released during storage (Noël *et al.*, 1999).

The threshold of *trans*-2-nonenal is about 0.1 $\mu\text{g/l}$ and it has been suggested that its level provides a indication of the degree of staling. Other carbonyl compounds formed from the lipids in beer by irradiation with light include the C_9 , C_{10} , and C_{11} -alka-2,4-dienals (thresholds 0.5, 0.3 and 0.01 ppb respectively) (Tressl *et al.*, 1980). Using GC-O Evans *et al.* (1999) confirmed that during ageing the level of most aldehydes increased. As well as *trans*-2-nonenal, the levels of phenylacetaldehyde, methional, 4-methoxybenzaldehyde and heptanal increased but the level of octanal fell. The level of diacetyl and pentane-2,3-dione in a range of commercial beers is given in Table 19.11. Quantities in excess of 0.15 ppm impart a buttery flavour more noticeable in lagers than in ales. Bacterial contamination and petite mutants of yeast result in high levels of these diketones.

Although ^{18}O in the headspace was not incorporated into the carbonyl fraction during storage of bottled beer, it was involved in the oxidation of sulphites, polyphenols and isohumulones. Roughly 1 ml of air in a 300 ml bottle will give an oxygen content of 1 ppm, which is probably enough to oxidize all the reductones present in a light lager beer. The dissolved oxygen in beer rapidly disappears, usually without the immediate formation of an off-flavour, but the damage may have been done as beer contains compounds such as melanoidins and reductones, which act as oxygen carriers, and produce off-flavours at a later date. Chemically, reductones contain the grouping $-\text{C}(\text{OH})=\text{C}(\text{OH})-\text{C}=\text{O}-$ and the best characterized reductone is ascorbic acid (vitamin C) (4.96). Ascorbic acid has been detected in green malt and the leaves of green hops but is destroyed during kilning. Ascorbic acid, and other reductones, readily combine with oxygen and accordingly ascorbic acid finds use as a chill-proofing agent in beer (Chapter 15). Ascorbic acid (4.96) is reversibly oxidized to dehydroascorbic acid (4.97) but more extensive decomposition occurs under quite mild conditions. In model experiments designed to assess the efficiency of various substances to degrade valine to isobutyraldehyde by the Strecker mechanism, dehydroascorbic acid was 5–10 times more active than fructose which, in turn, was 2–3 times more active than glucose or sucrose or ascorbic, pyruvic or chlorogenic acids (Swain and Casey, 1963). Ascorbic acid is usually estimated colorimetrically with the oxidation-reduction indicator, 2,6-dichlorophenolindophenol (20.10), but other reductones will interfere. The Indicator Time Test (ITT) (Gray and Stone, 1939), which measures the decolorization of 2,6-dichlorophenolindophenol, gives an indication of the oxidation-reduction or redox level of a beer.

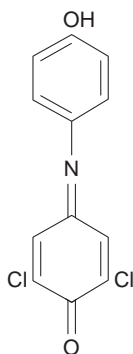

2,6-Dichlorophenolindophenol
(20.10)

The bitterness of beer declines during storage (Fig. 20.8). De Cooman *et al.* (2000) found that both in lagers and top-fermented beers the *trans*-iso- α -acids deteriorated at a

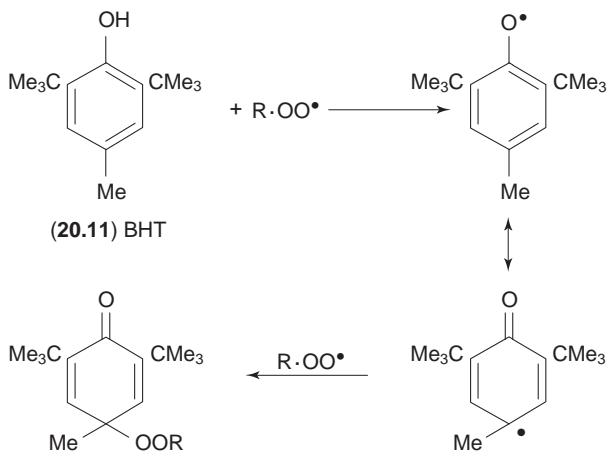
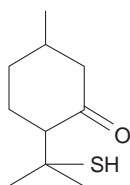

Fig. 20.11 Antioxidant activity of Butylatedhydroxytoluene (BHT).

much faster rate than the *cis*-iso- α -acids. During the first 15 months the loss of iso- α -acids was mainly due to decomposition of the *trans*-isomers. In the *trans*-iso- α -acids the double bonds in the 3-methyl-2-butenyl- and the 4-methyl-3-pentenyl- side chains lie close together and it is suggested that this increases their susceptibility to autoxidation. Therefore the *cis-trans* ratio of the iso- α -acids gives a measure of a beer's deterioration. As discussed in Chapter 19 the flavours due to 4-vinylphenol and 4-vinylguaicol (**4.134**, threshold, 0.3 mg/l) are regarded as off-flavours in most beers but, with orcinol, are responsible for the clove-like character of *Weizenbier*.

Beer also contains many antioxidants derived mainly from the polyphenols present in the malt and hops. Phenols react readily with free radicals but form mesomeric radicals which are not sufficiently energetic to propagate the free radical chain further (Lacan *et al.*, 2000). For example, one molecule of the synthetic antioxidant, butylatedhydroxytoluene (BHT) (**20.11**) can destroy two hydroperoxy radicals (Fig. 20.11).

The level of some volatile sulphur compounds increases during storage. We saw in the last chapter that low levels of hydrogen sulphide are acceptable in ales and dimethyl sulphide is characteristic of some lagers (Table 19.20). As mentioned earlier, beers bottled in clear glass bottles and exposed to sunlight develop skunky 'sunstruck' flavours due to 3-methyl-2-butenyl thiol (**8.48**, prenyl mercaptan) which has a very low threshold of 0.005 ppb in water and 0.05 ppb in beer. Other beers acquire a flavour described as 'catty' or *Ribes*, as a similar aroma is given off by the leaves and stems of flowering currants (*Ribes* spp.). The development of this flavour is closely correlated with the amount of headspace air (Clapperton, 1976). In beers bottled with high volumes of



8-Mercapto-*p*-menthan-3-one
(**20.12**)

headspace air the flavour develops rapidly over six weeks but thereafter slowly declines. One substance responsible for the catty flavour is 4-mercaptopentan-2-one (threshold, 0.005 ppb in water, 0.05 ppb in beer). Beers with strong catty odours contained 1.5 ppb of the mercaptopentanone but there may be other beer constituents which contribute to this off-flavour. Elsewhere (see Table 20.11 on page 750) 8-mercapto-*p*-menthan-3-one (**20.12**, *p*-menthane-8-thiol-3-one) has been proposed as a reference standard for the catty (*Ribes*) flavour.

Gijs *et al.* (2002) applied Aroma Extract Dilution Analysis to fresh and aged beers (five days at 40 °C, pH4.2) and found that the Flavour Dilution (FD) values were increased in the aged beer for ethyl butyrate, dimethyl trisulphide, 2-acetylpyrazine, methional, 2-methoxy-pyrazine, maltol (**9.11**), γ -nonalactone, β -damascenone (**8.165**), and ethyl cinnamate. β -Damascenone and an unknown compound, with a 'dentist', smoked, vanilla odour with the same FD (243) are probably the most important odours in aged beer and more important than *trans*-2-nonenal (FD 81). Strecker degradation of the amino acid methionine gives methional, (3-(methylthio)propionaldehyde), which is responsible for the worty flavour of alcohol-free beers (Perpète and Collin, 1999). It is also the precursor of dimethyl trisulphide which develops as beer ages (Gijs *et al.*, 2000; Gijs and Collin, 2002).

β -Damascenone (8*E*-megastigma-3, 5, 8-trien-7-one, (**8.165**)), a degradation product of the carotenoid neoxanthin, is a key odour compound in a number of fruits and has an extremely low threshold (0.02–0.09 ng/g (ppb) in water). It is present in hops but is also found in unhopped wort. Hopped wort contained 450 ng/g but this was reduced during fermentation so fresh beers contained only low levels of β -damascenone (6–25 ng/g). However, during ageing (five days at 40 °C) the level increased to as much as 210 ng/g (Chevance *et al.*, 2002). Experiments with β -glucosidase suggest that the production of β -damascenone during beer ageing can be partially explained by the hydrolysis of glucosides. This was confirmed as the production of β -damascenone fell in beers aged at higher pH values (Gijs *et al.*, 2002). The production of dimethyl trisulphide also fell at higher pH values but that of 3-(methylthio)propionaldehyde increased.

20.4 Sensory analysis

Sensory analysis uses the human senses to assess flavours. It has been discussed in books by Amerine *et al.* (1965), the International Organization for Standardization (1983), Meilgaard *et al.* (1987), Piggott (1988) and Lawless and Heymann (1999). Analytica-EBC/ASBC give details for paired comparison tests, triangular tests, duo trio tests, determining the threshold of added substances, description analysis, ranking tests and provide a flavour terminology. For other tests, for example, the 'A' or 'not A' test, the 2-out-of-5 test, the Scheffe paired comparison test and the multiple paired comparison test, reference should be made to the above texts.

Analytica-EBC/ASBC first give a glossary of terms and definitions, then detailed instructions for carrying out sensory analysis. They suggest a layout for a medium-sized sensory evaluation area for brewery control work; consumer preference testing requires a much larger panel. The tasting room should be situated in a quiet area free from any smells. They suggest six booths 60–80 cm wide with a counter top 40–50 cm deep and 90 cm high. Dividers between the booths should project c. 46 cm and extend from the floor to the ceiling. Walls, floors and ceiling should be of smooth non-absorbing material of a pale neutral colour. The booths may be equipped with a hatch (sliding door, bread

box or carousel) so the samples can be delivered from an adjacent preparation room. The booths should be odour free with a slight overpressure of air that has been filtered through charcoal. The air should be at 22 °C and at 45–55% relative humidity. Shadow-free illumination at 70–80 foot candles should be provided. Odourless water and salt-free crackers should be available to cleanse the palate. A small sink may be provided but, if so, the drains should be readily dismantled to allow for cleaning. The booth may be equipped with a computer station so that the panellists' observations can be analysed quickly and automatically without recourse to the forms detailed below.

Liquid samples are best provided in straight-sided cylindrical 250 ml (8 oz.) glasses which may be deeply coloured to mask differences in colour, clarity or foaming. The glasses should be washed in an odour-free detergent such as sodium hexametaphosphate not more than 12 hours before the test. 50–100 ml of sample should be served at the designated temperature. A sample temperature of 12 °C is suitable for full perception of flavour, such as detecting faults or small differences. Mouth-feel and drinkability are best evaluated at a lower temperature, e.g., 8 °C. For preference tasting, the beer should be tasted at the usual drinking temperature, making due allowance for warming which may occur between pouring and drinking. The number of samples presented to each assessor, their order and coding should be carefully monitored. The order of presentation should be balanced so that each sample appears in a given position an equal number of times. For example, the possible positions for three products A, B, and C to be compared in a ranking test are:

ABC ACB BCA BAC CBA CAB

so a multiple of six assessors should be chosen so that the six possible combinations can be presented an equal number of times.

The order of presentation should be randomized, e.g., by drawing sample cards from a bag or using a table of random numbers. Similarly, the samples should be coded with three-digit random numbers. Too many samples should not be presented at a single session to avoid sensory fatigue. Panel sessions should be held before meals preferably between 10 and 12 a.m. The assessors should be carefully instructed what is required of them. The amount of sample to be tasted, how long it is to be held in the mouth and whether it should then be swallowed or expectorated should be clearly stated. The use of the scoresheet, any terminology and the interpretation of the scales used should be explained. Finally, the information sought in the test and the type of judgement/evaluation required, e.g., difference, descriptive, preference, acceptance should be stated. At the end of the test, at a location away from the tasting area, the codes may be disclosed and the assessors allowed to discuss the results among themselves and/or with the panel leader. It is the job of the panel leader to keep the panellists motivated and give them regular reports on their results.

Sensory tests have two main applications: (i) those in which the primary aim is to describe the product and (ii) those in which the aim is to distinguish between two or more products. With regard to the latter it is important to distinguish between the need to know if there is a difference at all, the magnitude of that difference, the direction (or quality) of that difference, the effect of that difference, for example, with regard to preference, and whether all or only part of the population detects a difference. Analytica-EBC/ASBC provide a simplified key to decide which tests are relevant to a given problem.

For the selection and training of assessors, EBC/ASBC suggest that you interview and screen two to three times the number of assessors required. The general health of the

candidates should be checked, whether they are on regular medication, whether they smoke, and their ability to communicate verbally. Smokers are not automatically disqualified. Candidates can then be subjected to matching tests. For example, they are presented with four to six coded (A–F) but unidentified common flavours (sucrose, tartaric acid, caffeine, sodium chloride, tannic acid and ferrous sulphate) and asked to familiarize themselves with the tastes using as much odourless water as they like to cleanse their palates. They are then presented with the same samples labelled with three-digit numbers and asked to say which of the standards each resembles. Candidates scoring less than 80% matches should be rejected. For detection tests, candidates are presented with three samples containing beer to which additions have been made versus control samples in a Triangular test (see later). The additions can be the above flavour standards, first at four to six times the threshold, and then at two to three times the threshold. Candidates scoring less than 60% at the higher level should be rejected and preference given to those scoring 100% at the higher level and over 60% at the lower level. Sequential triangular tests can be used to find the taste acuity of the candidates but a more important skill is the ability to detect (and grade) individual flavour notes in a ‘fog’ of other impressions.

For ranking tests, the candidates are asked to discriminate a set of beer samples to which additions have been made and which are presented in a random order. For example; 0, 0.6, 1.2, and 1.8 mg/l geraniol. Other suggested materials are sucrose, sodium chloride, isoamyl acetate, dimethyl sulphide and acetic acid. Only candidates that rank samples correctly, or invert only adjacent pairs, should be accepted. Finally, to test for descriptive ability, present sets of five to ten stimuli that are typical of the samples to be evaluated. Present the samples one at a time and ask the candidate to describe his or her response. Suitable substance and concentrations are given in Analytica-EBC/ASBC. However, most brewing companies use their own employees as tasters and this leads to little or no scope for selecting people with good sensory ability. In addition, employees often miss panel sessions and cannot devote time for training because of other duties. Accordingly, one brewery company has recruited an external expert sensory panel. From 70 applicants, ten were selected and employed for three three-hour sessions per week. The members of the panel were trained as tasters, not just ‘beer’ tasters, and were exposed to a wide range of foods and drinks. After training, the 95% confidence limits for this new panel were less than 5% whereas those for the old in-house panel were 20–30% (Hegarty *et al.*, 2001).

For training, Analytica-EBC/ASBC suggest that the assessors should be instructed to be objective and ignore likes and dislikes unless specifically asked for preference information. The assessors should normally proceed in the order appearance, odour, taste, and aftertaste. When assessing odour, the assessors should take short rather than long sniffs and not sniff too many times so they become fatigued and confused. As well as training in recognition and detection of basic tastes and odours, the panel should be trained in the use of descriptive language and scales. Samples should be presented to illustrate grainy, dry hop, kettle hop and overage flavours. The panel leader should analyse daily results and note for each assessor any obvious defects such as drift, lack of interest, or failure to detect obvious product variations. Such assessors should be called for special training. Most tasters will require attention at least three or four times a year.

Because of the many opportunities for variability and bias resulting from the use of human subjects, reports of sensory tests should contain more detail than the reports of physical or chemical measurements. The report should begin with a summary, of not more than 110 words, answering the following:

- What was the objective?
- What were the results?
- What was done?
- What can be concluded?

The objective of the test should be clearly stated with a clear definition of the problem and the approach taken to solve it. The test objectives should be agreed before the experiment. Sufficient experimental detail should be given to allow the study to be repeated. The experimental design should be given showing how it meets the objectives, as should the sensory tests used, the measurements made, and the make up and previous experience of the panel. Finally, details of sample preparation and presentation, the information given to the panel and the statistical techniques used to analyse the results should be reported. The results should be presented in the form of tables or figures (not both) and discussed briefly stating whether they support or fail to support any original hypothesis. The report should end with clear-cut conclusions.

The paired comparison test may be either (i) a directional difference test or (ii) a paired preference test; it can also be used in assessor training. The former is used to determine in what way a particular sensory characteristic differs between the two samples, e.g., more sweet or less sweet. As a rule at least seven assessors are required but up to 30 can be used (more for consumer tests). They should be familiar with the characteristic to be examined. For example, if the test concerns detection of an off-flavour, the panel should first be allowed to taste a sample free of any off-flavour and, if possible, a demonstration of the off-flavour. In general the inclusion of controls (reference substances) is advisable. Paired samples are offered simultaneously, an equal number of AB and BA with random three-digit codes. The assessors should be instructed to examine sets in a specified order, e.g., always from left to right, however, they may make repeated tests of any sample while tasting is in progress. Specimen answer forms are given in Fig. 20.12. The test supervisor may use one of the following two possibilities:

1. adopt the 'forced choice' technique in which the assessor is asked to choose one sample or the other (by guessing if no difference is perceived) or
2. allow the answer 'no difference'.

In most test situations (two-sided) the test question does not distinguish between the samples and the reply may favour one or the other sample. One-sided tests are occasionally used when the characteristic can vary only in one direction. The results are collected and interpreted by reference to Fig. 20.13 and Tables 20.6 and 20.7. With the 'forced choice' technique a significant difference or preference is established if the number found is equal to or larger than that given in the table. The 'no difference' technique is not amenable to formal statistical analysis but two approaches can be used. In one the 'no difference' replies are ignored and in the other half the 'no difference' replies are allocated to each category. The test report should allow full identification of the samples examined, the characteristic studied, whether or not reference substances were used, and the results with their probability levels.

The triangular test is used to determine whether a sensory difference is apparent between two samples. The assessor is presented with a set of three samples, two of which are identical. After tasting the assessors complete a form similar to Fig. 20.14 showing the sample perceived to be different and the results are interpreted by reference to Table 20.8. 'No difference' results should be considered invalid. In the duo trio test the

Directional Difference Test

Name _____ Date _____
day/month/year

Object of Test _____
Test Criterion _____

Test Pairs Which sample is more _____?

Sample No. Sample No.

Comments

Paired Preference Test

Name _____ Date _____
day/month/year

Object of Test _____
Test Criterion _____

Test Pairs Which sample is more _____?

Sample No. Sample No.

Comments

Fig. 20.12 Specimen answer forms for the directional difference test and the paired preference test (*Analytica-EBC*).

	Two-sided test	One-sided test
Directional difference test	Question: which sample has the stronger intensity of the characteristics studied?	Question: which sample has the stronger intensity of the characteristics studied?
	Count the number of replies citing one of the two samples the more frequently.	Count the number of replies choosing the sample of interest.
	Conclude that the intensity for this sample is significantly stronger than for the other if the number obtained is greater than or equal to that shown in Table 20.7.	Conclude that this stronger intensity is significantly apparent if the number of positive replies is greater than or equal to the number shown in Table 20.6.
Paired preference test	Question: Which sample do you prefer?	Question: Which sample do you prefer?
	Count the number of replies citing one of the two samples the more frequently.	Count the number of replies choosing the sample of interest.
	Conclude that this sample is significantly preferred to the other if the number obtained is greater than or equal to that shown in Table 20.7.	Conclude that there is a preference for the sample of interest if the number of positive replies is greater than or equal to the number shown in Table 20.6.

Fig. 20.13 Questions and interpretations of the directional difference test and the paired preference test (*Analytica-EBC*).

Table 20.6 One-sided test ($P = 0.50$ with n replies)

Number of replies	Minimum number of positive replies for significance level of $\alpha \leq$		
	0.05	0.01	0.001
7	7	7	–
8	7	8	–
9	8	9	–
10	9	10	10
11	9	10	11
12	10	11	12
13	10	12	13
14	11	12	13
15	12	13	14
16	12	14	15
17	13	14	16
18	13	15	16
19	14	15	17
20	15	16	18
21	15	17	18
22	16	17	19
23	16	18	20
24	17	19	20
25	18	19	21
30	20	22	24
35	23	25	27
40	26	28	31
45	29	31	34
50	32	34	37
60	37	40	43
70	43	46	49
80	48	51	55
90	54	57	61
100	59	63	66

The values given in the tables were calculated from the exact formula binomial law for parameter $P = 0.50$ with n repetitions (replies).

When the number of replies is higher than 100 use the following formula based on the approximation of the binomial law by the normal law which gives the actual minimum number of assessments to be obtained with a maximum error equal to at most one unit. Minimum number of replies: nearest whole value to $(n + 1)/2 + k\sqrt{n}$ in which k is chosen from the table below.

Level of significance $\alpha \leq$	K	
	One-sided	Two-sided
0.05	0.82	0.98
0.01	1.16	1.29
0.001	1.55	1.65

Tables for calculating other significance levels may be found in Roessler *et al.* (1978) and Fernandus *et al.*

assessors are first presented with the identified reference sample. This is followed by two coded samples, one of which is identical to the reference sample. The assessor is asked to identify the odd sample and complete the form Fig. 20.15 and the results are interpreted by reference to Table 20.9.

The measurement of the threshold of added substances is not carried out routinely but is required when a new substance is found which may or may not influence the flavour of beer. The experimental design used is known in psychophysics as the forced choice

Table 20.7 Two-sided test* ($P = 0.50$ with n replies)

Number of replies	Minimum number of positive replies for significance level of $\alpha \leq$		
	0.05	0.01	0.001
7	7	—	—
8	8	8	—
9	8	9	—
10	9	10	—
11	10	11	11
12	10	11	12
13	11	12	13
14	12	13	14
15	12	13	14
16	13	14	15
17	13	15	16
18	14	15	17
19	15	16	17
20	15	17	18
21	16	18	19
22	17	18	19
23	17	19	20
24	18	19	21
25	18	20	21
30	21	23	25
35	24	26	28
40	27	29	31
45	30	32	34
50	33	35	37
60	39	41	44
70	44	47	50
80	50	52	56
90	55	58	61
100	61	64	67

* Refer to footnotes of Table 20.6 (from *Analytica-EBC* (1998)).

Name _____ Date _____
day/month/year

Product submitted to test _____

Problem: 3 samples are presented to you; circle the number of
that which is different from the other 2.

Set of 3 samples

Comments

Fig. 20.14 Specimen answer form for the triangular test (*Analytica-EBC*).

modification of the ascending method of limits test. Sixteen or more assessors receive six sets of three beers each consisting of two controls and one test sample. Test samples increase in concentration by a constant factor, usually 2.0. An approximate threshold (t_a) may be determined first using five to ten assessors and increasing the concentration by a

Table 20.8 Minimum number of correct replies to establish significance at various probability levels for the triangular test (one-sided $p = 1/3$)*

Number of replies	Minimum number of correct replies for a significance level of $\alpha \leq$			Number of replies	Minimum number of correct replies for a significance level of $\alpha \leq$		
	0.05	0.01	0.001		0.05	0.01	0.001
5	4	5	–	53	24	27	30
6	5	6	–	54	25	27	30
7	5	6	7	55	25	28	30
8	6	7	8	56	26	28	31
9	6	7	8	57	26	28	31
10	7	8	9	58	26	29	32
11	7	8	10	59	27	29	32
12	8	9	10	60	27	30	33
13	8	9	11	61	27	30	33
14	9	10	11	62	28	30	33
15	9	10	12	63	28	31	34
16	9	11	12	64	29	31	34
17	10	11	13	65	29	32	35
18	10	12	13	66	29	32	35
19	11	12	14	67	30	33	36
20	11	13	14	68	30	33	36
21	12	13	15	69	31	33	36
22	12	14	15	70	31	34	37
23	12	14	16	71	31	34	37
24	13	15	16	72	32	34	38
25	13	15	17	73	32	35	38
26	14	15	17	74	32	35	39
27	14	16	18	75	33	36	39
28	15	16	18	76	33	36	39
29	15	17	19	77	34	36	40
30	15	17	19	78	34	37	40
31	16	18	20	79	34	37	41
32	16	18	20	80	35	38	41
33	17	18	21	81	35	38	41
34	17	19	21	82	35	38	42
35	17	19	22	83	36	39	42
36	18	20	22	84	36	39	43
37	18	20	22	85	37	40	43
38	19	21	23	86	37	40	44
39	19	21	23	87	37	40	44
40	19	21	24	88	38	41	44
41	20	22	24	89	38	41	45
42	20	22	25	90	38	42	45
43	20	23	25	91	39	42	46
44	21	23	26	92	39	42	46
45	21	24	26	93	40	43	46
46	22	24	27	94	40	43	47
47	22	24	27	95	40	44	47
48	22	25	27	96	41	44	48
49	23	25	28	97	41	44	48
50	23	26	28	98	41	45	48
51	24	26	29	99	42	45	49
52	24	27	30	100	42	46	49

The values in this table were calculated from the exact formula: binomial law for parameter $p = 1/3$ with n repetitions (replies). When the number of replies is larger than 100, numbers of required correct replies may be obtained from the following formula based on the approximation binomial law by the normal law, with a maximum error equal to one unit: $x = 0.4714z\sqrt{n} + [(2n + 3)/6]$ where $z = 1.64$ for $\alpha \leq 0.05$, 2.3 for $\alpha \leq 0.01$, and 3.10 for $\alpha \leq 0.001$. The minimum number of correct replies is x if x is a whole number or the next higher integer if x is not a whole number. Tables for significance levels other than those listed here may be found in Amer. Soc. Testing and Materials (1979) and Jones (1956) (from *Analytica-EBC* (1988)).

Table 20.9 Significance of results in 'one-sided test' ($P = 0.50$ with n replies)

Number of replies	Minimum number of positive replies for significance level of $\alpha \leq$		
	0.05	0.01	0.001
7	7	7	—
8	7	8	—
9	8	9	—
10	9	10	10
11	9	10	11
12	10	11	12
13	10	12	13
14	11	12	13
15	12	13	14
16	12	14	15
17	13	14	16
18	13	15	16
19	14	15	17
20	15	16	18
21	15	17	18
22	16	17	19
23	16	18	20
24	17	19	20
25	18	19	21
30	20	22	24
35	23	25	27
40	26	28	31
45	29	31	34
50	32	34	37
60	37	40	43
70	43	46	49
80	48	51	55
90	54	57	61
100	59	63	66

The values given in the tables were calculated from the exact formula binomial law for the parameter $P = 0.50$ with n repetitions (replies). When the number of replies is larger than 100, numbers of correct replies may be obtained from the following formula based on the approximation of the binomial law by the normal law, with a maximum error equal to one unit: $x = (n + 1)/2 + k \sqrt{n}$ where $k = 0.82$ for $\alpha \leq 0.05$; and $k = 1.16$ for $\alpha \leq 0.01$; and 1.55 for $\alpha \leq 0.001$. Tables for significance levels other than those listed here may be found in Roessler *et al.* (1978) and Fernandus *et al.* (1970) (from *EBC-Analytica* (1998)).

Name _____ Date _____
day/month/year

Product submitted to test _____

Problem: The sample on the left is a control. Of the other 2 samples, one is the same as the control and the other is different. Indicate the different sample.

Set of 3 samples



Comments

Fig. 20.15 Specimen answer form for the triangular test (duo trio) (*Analytica-EBC*).

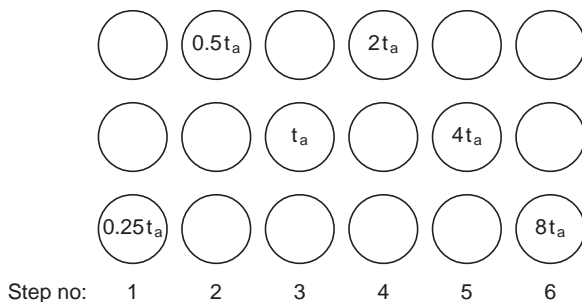

Fig. 20.16 Threshold of added substances: example of the presentation of the six triangles t_a = approximate threshold (*Analytica-EBC*).

Ascending method of limits

Date _____ Assessor _____

You have received 6 sets of beer samples. Each set is a triangle consisting of 2 identical controls and 1 test sample containing an added substance. Concentrations of the added substances increase from left to right. Please locate as many as you can on the test samples, indicating their position with a check mark in the corresponding box in each column. Avoid sensory fatigue: locate strong samples by smell or by taking very small sips, conserving your discriminatory power for those sets of 3 beers near your threshold. Review your results with a test supervisor.

Triangle no.:	1	2	3	4	5	6
	□	□	□	□	□	□
	□	□	□	□	□	□
	□	□	□	□	□	□

Describe the flavour of the added substance _____

Fig. 20.17 Threshold of added substances; example of questionnaire (*Analytica-EBC*).

factor of 3.0. The dilution series in the main test is then: step 1, $0.25 t_a$; step 2, $0.5 t_a$; step 3, t_a ; step 4, $2 t_a$; step 5, $4 t_a$; and step 6, $8 t_a$ set out as illustrated in Fig. 20.16. The assessors are asked to indicate the position of the test sample in each set of three beers. An example of the questionnaire is given in Fig. 20.17. For each assessor the best estimated threshold (BET) is calculated as the geometric mean of the highest concentration missed and the next highest adjacent concentration. A histogram of the individual BETs of the group is produced and from it the group threshold is the geometric mean of the BETs. In the extended form of the test, critical sets of three beers are repeated two to four times until both the assessor and the test supervisor agree that the threshold has been successfully bracketed by the assessor. For assessors at the top and bottom of the range, extra concentration steps may be required.

For description analysis 15–30 trained assessors are required. In a preliminary step, assessors agree which attributes (usually 10 to 40) will be used, and a scale is defined for each attribute, if possible with the use of reference standards. In the test itself, after tasting the sample, assessors award an intensity score for each attribute. Results may be used to form a sensory profile of the sample, and profiles of two or more samples may be compared using statistical techniques. The attributes to be rated may be chosen from the 122 terms and the 14 flavour classes of the standard terminology (Table 20.11). Ten to 20 attributes are chosen for the simple descriptive test and up to 50 or more for the full test.

Examples of intensity scales of proven usefulness are:

Scale A

0 1 2 3 4 5 6 8 7 9

or

0 1 2 3 4 5
not just slight moderate strong very
present recognizable strong strong strong

Scale B

weak 0 0 0 0 0 0 0 strong

Scale C

A 15 cm line with descriptive terms 1.5 cm from each end

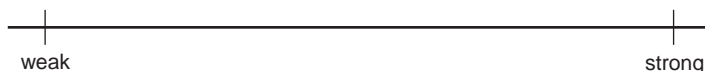

Assessors place a mark on the line to indicate intensity. A numerical score can be obtained by measuring the distance, in cm, from the left hand end of the line to the mark. Reference standards should be used where possible to anchor two or three points on the scale.

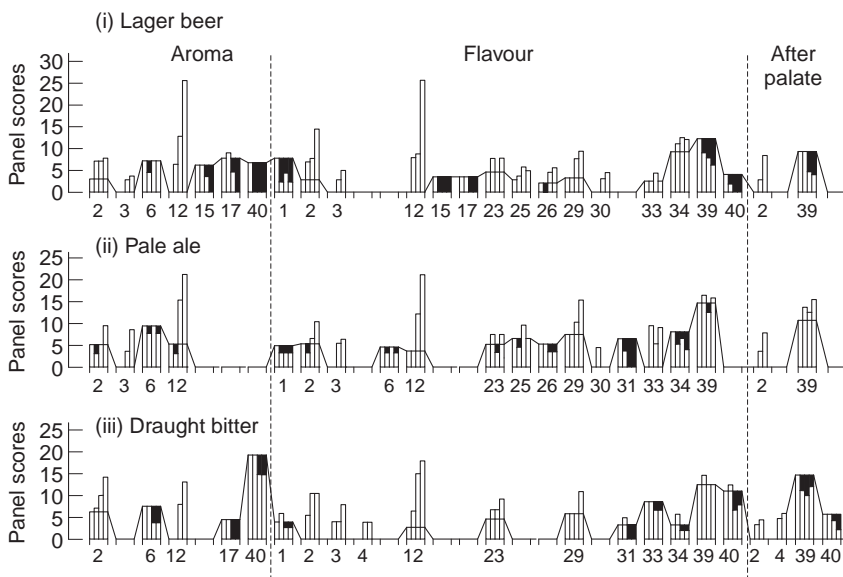

Fig. 20.18 Description analysis; profile analysis of the effects on flavour of the addition of 0.2, 0.6 and 1.8 mg/l of diacetyl to three different beers. Histograms show the scoring of intensity of aroma and flavour qualities by a panel of eight assessors. Scores are entered from left to right for the control beer and the corresponding beers resulting from the three increasing levels of addition of diacetyl. Continuous lines depict the profile descriptions of the flavours of the unadulterated beers. Key to qualities: 1 liveliness (CO_2 tingle), 2 sweet, 3 sickly, 4 toffee-like, 6 estery, 12 diacetyl, 15 cabbagey, vegetable water, 17 sulphury, 23 smooth, 25 acidic (sharp), 26 sour, 29 mouth coating, 30 astringent, 31 drying, 33 body, 34 watery, 39 bitter, and 40 hoppy (*Analytica-EBC*).

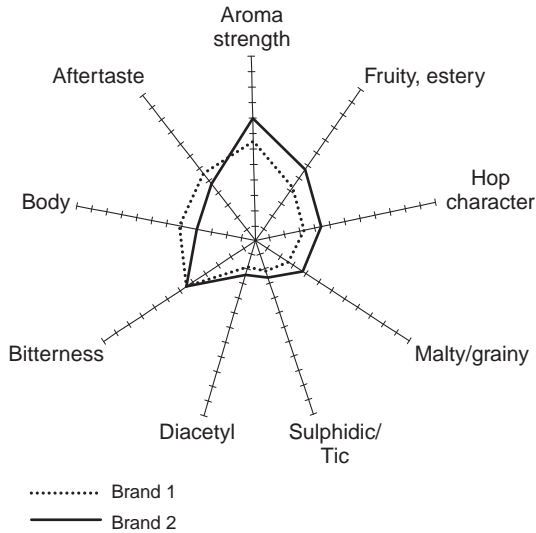

Fig. 20.19 Description analysis: example of spider web plot (*Analytica-EBC*). Spider web plot showing two different beers. No. of assessors, $n = 26$. Mean scores are shown as distance from the centre. The width of the line is the last significant difference about the mean calculated as the studentized range, SR. For example, the following ANOVA table was produced for the hop character means of two brands.

Source	df	SS	MSE	F-ratio
Total	51	664.32	—	—
Between brands	1	64.32	64.32	5.63
Error	50	600.00	12.00	—

The error bands would be calculated by finding

$$SR = Q\sqrt{\frac{MSE}{N}} = 2.85\sqrt{\frac{12}{26}} = 1.933$$

Where Q is the upper 5 percentage points for two treatments and 50 degrees of freedom (from Malek *et al.*, 1982).

For each attribute the average rating is calculated and the results presented either as a Table or as a histogram, for example as in Fig. 20.18. An alternative is a spider web plot (Fig. 20.19) where mean scores are shown as the distance from the centre. The ranking test is used to place a series of test samples (usually from 3 to 6) in rank order according to a given characteristic (criterion). The criterion may be the intensity of a single sensory attribute, or a group of related attributes, or a total impression. The test is especially suitable in those situations where scale estimates are not meaningful and it is convenient to rank a series of samples according to preference or some other criteria. Assessors (n) receive the test samples (k) simultaneously in random order and rank them according to the specified criterion. The rank sums (R) are calculated and evaluated statistically with the aid of Friedman's test. Specimen answer forms are given in Figs 20.20 and 20.21. In preference tests, assessors are instructed to assign rank 1 to the preferred sample, rank 2 to the next preferred, etc. For intensity tests, assessors are instructed to assign rank 1 to

the lowest intensity, rank 2 to the next lowest etc. Friedman's F can be calculated by the formula:

$$F = \frac{[(R_1 - \bar{R})^2 + \dots + (R_k - \bar{R})^2]}{k\bar{R}/6 - A}$$

where \bar{R} is the mean rank sum calculated as

$$\bar{R} = (R_1 \dots + R_k)/k = n(k + 1)$$

Name _____ Date _____
(day/month/year)

Products submitted to test _____

Problem: You have received 5 samples placed as follows:

left	mid left	mid	mid right	right

Taste the samples from left to right and write '1' in the box of the sample you like best, '2' in the box of the sample you like next best, and so on.

Comments:

Fig. 20.20 Specimen answer for a ranking test (preference) (*Analytica-EBC*).

Ranking Test

Name Ancketill Brewer Date 21/4/87
(day/month/year)

Products submitted to test Lager 11-12° O.G

Problem: You have received 4 samples labelled with the three-digit numbers shown in the column marked 'Samples presented'. Taste the samples and place them in rank order according to **bitterness**, listing the **most bitter** in the column marked 4, the **next most bitter** in the column marked 3, etc. If two samples appear the same, preferably make a 'best guess' as to their rank order, or if you cannot guess, indicate under "Comments" the sample numbers that could not be differentiated.

Samples presented	Order of rank				Comments
	1.	2.	3.	4.	
set *1 <u>149</u> , <u>251</u> , <u>347</u> , <u>428</u> ,	347,	428,	251,	149	428 ≅ 251
set *2 <u>014</u> , <u>017</u> , <u>146</u> , <u>155</u> ,	017,	146,	155,	014	
set *3 <u>098</u> , <u>123</u> , <u>233</u> , <u>473</u> ,	233,	123,	473,	098	123 ≅ 473 ≅ 098

Comments:

4 products were compared in set *1, then presented again in sets 2 and 3 with different codes. Text items which are underlined were filled in by the panel leader before the test. Text in italics is the assessor's response. The codes used for this assessor were: Sample A = 347, 146, 233; Sample B = 251, 017, 473; Sample C = 428, 014, 098; Sample D = 149, 155, 123.

Fig. 20.21 Specimen answer for a ranking test (bitterness) (*Analytica-EBC*).

Table 20.10 Ranking test; upper α probability points for the χ^2 -distribution

No. of samples (k)	No. of degrees of freedom of χ^2 (df = n - 1)	α level of significance, %	
		0.05	0.01
3	2	5.99	9.21
4	3	7.81	11.34
5	4	9.49	13.28
6	5	11.07	15.09
7	6	12.59	16.81
8	7	14.07	18.47
9	8	15.51	20.09
10	9	16.92	21.67
11	10	18.31	23.21
12	11	19.67	24.72
13	12	21.03	26.22
14	13	22.36	27.69
15	14	23.68	29.14
16	15	25.00	30.58
17	16	26.30	32.00
18	17	27.59	33.41
19	18	28.87	34.80
20	19	30.14	36.19
21	20	31.41	37.57
22	21	32.67	38.93
23	22	33.92	40.29
24	23	35.17	41.64
25	24	36.41	42.98
26	25	37.65	44.31
27	26	38.88	45.64
28	27	40.11	46.96
29	28	41.34	48.28
30	29	42.56	49.59
31	30	43.77	50.89

From *EBC-Analytica* (1998).

when n is the number of assessments. If F exceeds the upper critical value of χ^2 with k - 1 degrees of freedom (Table 20.10) it can be concluded that there is a significant difference between the samples. If practical it is best to prohibit ties as the statistics become cumbersome. In the equation above A is an adjustment for ties; if no ties are present A = 0. If ties are present consult *Analytica-EBC/ASBC* for the statistical treatment. The multiple comparison procedure according to Friedman is also given. The Least Significant Difference (LSD) within the set of rank sums is given by the formula:

$$\text{LSD}_{\text{rank}} = t_{\alpha/2,0.00} \sqrt{(k\bar{R}/3)}$$

where $t_{\alpha/2,0.00}$ is Student's t, which equals 1.96 at the 5% level and 2.58 at the 1% level of significance. Any two rank sums which differ by more than the LSD are significantly different.

Finally, *Analytica-EBC/ASBC* describe an internationally accepted flavour terminology for beer. It names and defines each of 122 separately identifiable flavour notes which can occur in beer (Table 20.11) The terminology was based on the principles that:

1. Each separately identifiable flavour characteristic has its own name.
2. Similar flavours are placed together.

Table 20.11 Description of the terminology system

Particular relevance: O = Odour T = Taste M = Mouth-feel W = Warming Af = Afterflavour

Class term	First tier	Second tier	Relevance	Comments, synonyms, definitions	Reference standard
<i>Class 1: aromatic, fragrant, fruity, floral</i>					
0110	Alcoholic		OTW	General effect of ethanol and higher alcohols	Ethanol, 50 g/l
	0111	Spicy	OTW	Allspice, nutmeg, peppery, eugenol: see also 1003 Vanilla	Eugenol, 120 µg/l
	0112	Vinous	OTW	Bouquet, fusely, wine-like	(white wine)
0120	Solvent-like		OT	Like chemical solvents	
	0121	Plastics	OT	Plasticizers	
	0122	Can-liner	OT	Lacquer-like	
	0123	Acetone	OT		(Acetone)
0130	Estery		OT	Like aliphatic esters	
	0131	Isoamyl acetate	OT	Banana, pear drop	(Isoamyl acetate)
	0132	Ethyl hexanoate	OT	Apple-like with note of aniseed: see also 0142 Apple	(Ethyl hexanoate)
	0133	Ethyl acetate	OT	Light fruity solvent-like: see also 0120 Solvent-like	(Ethyl acetate)
0140	Fruity		OT	Of specific fruits or mixtures of fruits	
	0141	Citrus	OT	Citral, grapefruit, lemony, orange rind	
	0142	Apple	OT		
	0143	Banana	OT		
	0144	Blackcurrant	OT	Blackcurrant fruit; for blackcurrant leaves use 0810 Catty	
	0145	Melony	OT		(6-Nonenal, <i>cis</i> -or <i>trans</i> -)
	0146	Pear	OT		
	0147	Raspberry	OT		
	0148	Strawberry	OT		
0150	Acetaldehyde		OT	Green apples, raw apple skin, bruised apples	(Acetaldehyde)
0160	Floral		OT	Like flowers, fragrant	
	0161	2-Phenylethanol	OT	Rose-like	(2-Phenylethanol)
	0162	Geraniol	OT	Rose-like, different from 0161; taster should compare pure chemicals	(Geraniol)
	0163	Perfumy	OT	Scented	(Exaltolide musk)
0170	Hoppy		OT	Fresh hop aroma; use with other terms to describe stale hop aroma; does not include hop bitterness (see also 1200 Bitter)	
	0171	Kettle hop	OT	Flavour imparted by aroma hops boiled in kettle	
	0172	Dry-hop	OT	Flavour imparted by dry hops added in tank or cask	
	0173	Hop oil	OT	Favour imparted by addition of distilled hop oil	

Table 20.11 Continued

Class term	First tier	Second tier	Relevance	Comments, synonyms, definitions	Reference standard
<i>Class 2: resinous, nutty, green, grassy</i>					
0210	Resinous		OT	Fresh sawdust, resin, cedarwood, pinewood, spruce, terpenoid	
	0211	Woody	OT	Seasoned wood (uncut)	
0220	Nutty		OT	As in brazil nut, hazelnut, 'sherry-like'	
	0221	Walnut	OT	Fresh (not rancid) walnut	
	0222	Coconut	OT		
	0223	Beany	OT	Bean soup	(2,4,7-Decatrienal)
	0224	Almond	OT	Marzipan	(Benzaldehyde)
0230		Grassy	OT		
	0231	Freshly cut grass	OT	Green, crushed green leaves, leafy, alfalfa }	cis-3-Hexanol
	0232	Straw-like	OT	Hay-like	
<i>Class 3: cereal</i>					
0310	Grainy		OT	Raw grain flavour	
	0311	Husky	OT	Husk-like, chaff, <i>Glattwasser</i>	
	0312	Corn grits	OT	Maize grits, adjuncty	
	0313	Mealy	OT	Like flour	
0320	Malty		OT		
0330	Worty		OT	Fresh wort aroma; use with other terms to describe infected wort (e.g. 0731 Parsnip/celery)	
<i>Class 4: caramelized, roasted</i>					
0410	Caramel		OT	Burnt sugar, toffee-like	
	0411	Molasses	OT	Black treacle, treacly	
	0412	Licorice	OT		
0420	Burnt		OTM	Scorched aroma, dry mouth-feel, sharp, acrid taste	
	0421	Bread crust	OTM	Charred toast	
	0422	Roast barley	OTM	Chocolate malt	
	0423	Smoky	OT		
<i>Class 5: phenolic</i>					
0500	Phenolic				
	0501	Tarry	OT	Pitch, faulty pitching of containers	
	0502	Bakelite	OT		
	0503	Carbolic	OT	Phenol, C ₆ H ₅ OH	
	0504	Chlorophenol	OT	Trichlorophenol (TCP), hospital-like	
	0505	Iodoform	OT	Iodophores, hospital-like, pharmaceutical	

Class 6: soapy, fatty, diacetyl, oily, rancid

0610	Fatty acid		OT		
	0611	Caprylic	OT	Soapy, fatty, goaty, tallowy	(Octanoic acid)
	0612	Cheesy	OT	} Hydrolytic rancidity	(Isovaleric acid) Butyric acid 3 mg/l Diacetyl, 0.2–0.4 mg/l
	0613	Isovaleric	OT		
	0614	Butyric	OT		
0620	Diacetyl		OT		
0630	Rancid		OT	Butterscotch, buttermilk	
	0631	Rancid oil	OTM	Oxidative rancidity	
0640	Oily		OTM		
	0641	Vegetable oil	OTM	As in refined vegetable oil	
	0642	Mineral oil	OTM	Gasoline (petrol) kerosene (paraffin), machine oil	

Class 7: sulphury

0700	Sulphury		OT		
0710	Sulphitic		OT	Sulphur dioxide, striking match, choking, sulphurous-SO ₂	(KMS)
0720	Sulphidic		OT	Rotten egg, sulphury-reduced, sulphurous- RSH	
	0721	H ₂ S	OT	Rotten egg	(H ₂ S)
	0722	Mercaptan	OT	Lower mercaptans, drains, stench	(Ethyl mercaptan)
	0723	Garlic	OT		
	0724	Lightstruck	OT	Skunky, sunstruck	
	0725	Autolysed	OT	Rotting yeast; see also 0740 Yeasty	
	0726	Burnt rubber	OT	Higher mercaptans	
	0727	Shrimp-like	OT	Water in which shrimp have been cooked	
0730	Cooked vegetable		OT	Mainly dialkyl sulphides, sulphurous-RSR	
	0731	Parsnip/celery	OT	An effect of wort infection	
	0732	DMS	OT	(Dimethyl sulphide)	DMS, 100 µg/l
	0733	Cooked cabbage	OT	Over-cooked green vegetables	
	0734	Cooked sweet corn	OT	Cooked maize, canned sweet corn	
	0735	Cooked tomato	OT	Tomato juice (processed), tomato ketchup	
	0736	Cooked onion	OT		
0740	Yeasty		OT	Fresh yeast, flavour of heated thiamine (see also 0725 autolysed)	
	0741	Meaty	OT	Broth, cooked meat, meat extract, peptone, yeast broth	

Table 20.11 Continued

Class term	First tier	Second tier	Relevance	Comments, synonyms, definitions	Reference standard
<i>Class 8: oxidized, stale, musty</i>					
0800	Stale 0810	Catty	OTM	Old beer, overaged, overpasteurized	(Heat with air) (<i>p</i> -Methane-8-thiol-3-one)
			OT	Blackcurrant leaves, ribes, tomato plants, oxidized beer	
	0820	Papery	OT	Initial stage of staling, bready (stale bread crumb), cardboard, old beer, oxidized	(5 Methylfurfural, 25 mg/l)
0830	Leathery		OTM	Later stage of staling, often used in conjunction with 0211 Woody	
0840	Mouldy		OT	Cellar-like, leaf mould, woody	
	0841	Earthy	OT	Actinomycetes, damp soil, freshly dug soil, diatomaceous earth	(Geosmin)
	0842	Musty	OT	Fusty	
<i>Class 9: sour, acidic</i>					
0900	Acidic 0910 0920	Acetic Sour	OT	Pungent aroma, sharpness of taste, mineral acid	(Acetic acid)
			OT	Vinegar	
			OT	Lactic, sour milk: use with 0141 citrus for citrus-sour	
<i>Class 10: sweet</i>					
1000	Sweet 1001	Honey	OT		Sucrose 7.5 g/l
			OT	Can occur as effect of beer staling (e.g. odour of stale beer in glass), oxidized (stale) honey	
	1002	Jam-like	OT	May be qualified by subclasses of 0140 Fruity	
	1003	Vanilla	OT	Custard powder, vanillin	(Vanillin)
	1004	Primings	OT		
	1005	Syrupy	OTM	Clear (golden) syrup	
	1006	Oversweet	OT	Sickly sweet, cloying	
<i>Class 11: salty</i>					
1100	Salty		T		Sodium chloride, 1.8 g/l
<i>Class 12: bitter</i>					
1200	Bitter		TAf		(Isohumulone)

Table 20.11 Continued*Class 13: mouth-feel*

1310	Alkaline		TMAf	Flavour imparted by accidental admixture of alkaline detergent	(Sodium bicarbonate)
1320	Mouthcoating		MAf	Creamy, <i>onctueux</i> (Fr)	
1330	Metallic		OTMAf	Iron, rusty water, coins, tinny, inky	(Ferrous ammonium sulphate)
1340	Astringent	Drying	MAf	Mouth puckering, puckery, tannin-like, tart	Quercitrin, 240 mg/1*
1341			MAf	Unsweet	
1350	Powdery		OTM	O-Dusty cushion, irritating, (with 0310 Grainy) mill room smell	
1360	Carbonation		M	CO ₂ content	
	1361	Flat	M	Undercarbonated	60% of normal CO ₂ content for the product
	1362	Gassy	M	Overcarbonated	140% of normal CO ₂ content for the product
1370	Warming		WMAf	See 0110 Alcoholic and 0111 Spicy	

Class 14: fullness

1410	Body		OTM	Fullness of flavour and mouth-feel
	1411	Watery	TM	Thin, seemingly diluted
	1412	Characterless	OTM	Bland, empty, flavourless
	1413	Satiating	OTM	Extra full, filling
	1414	Thick	TM	Viscous, <i>épais</i> (Fr)

*Quercitrin is both astringent and bitter

3. No terms are duplicated for the same flavour characteristic. (In five cases, overlapping pairs of chemical name terms and generally descriptive terms had to be permitted. The five pairs are: 0131 isoamyl acetate and 0143 banana; 0132 ethyl hexanoate and 0142 apple; 0133 ethyl acetate and 0120 solvent like; 0613 isovaleric and 0612 cheesy; and 0732 DMS and 0734 cooked sweet corn.)
4. The system is compatible with the EBC Thesaurus for the Brewing Industry.
5. Subjective terms such as good/bad, young/mature, balanced/unbalanced are not included.
6. As far as possible the meaning of each term is illustrated with readily available reference standards.

The system (Table 20.11) consists of 14 classes given general names to indicate the area in which any given type of flavour should be sought. Descriptors carry a four-digit number. Some classes have a broader term (e.g. 0700 sulphury) that serves as a common descriptor for all the terms in the class; in other classes a suitable term is not available.

There are three kinds of descriptors: class terms, first-tier terms and second-tier terms. In general the first two contain common terms familiar to most people, and together they provide a vocabulary designed to fill nonspecialist needs. The flavour wheel (Fig. 20.22) is presented to facilitate the location of terms within the system. It is a memory aid and not a new system of classification. Despite the diversity of terms, a logical sequence is obtained in most cases, but certain discontinuities appear, as where 0700 sulphury follows 0640 oily. The second tier of terms, together with the reference standards, form the theoretical backbone of the system and also serve to define those first-tier terms for which a reference is not available, e.g., 0220 nutty comprises a group of flavour notes exemplified by walnut like, coconut like, beany, and almond like. The column 'Relevance' shows that most terms may be used to describe sensations of both odour (O) and taste (T). The letters M, W, and Af indicate that the terms may be used to describe mouth-feel effects, warming and after flavour. A number of terms that have been used in the past are given under 'Comments, synonyms, definitions' but their use should be discouraged in favour of the more precise description given in the Table. Thus, 0910 acetic is preferred to 'vinegar'. The flavour caused by caprylic and/or capric acids should be referred to as 0611 caprylic. The term 0630 rancid is used only for oxidative rancidity (carbonyl compounds) and is no longer used for a butyric flavour.

Analytica-EBC-ASBC provide a list of 27 compounds recommended for use as flavour reference standards together with methods of purification, difference thresholds and the range of values found in beer. In addition they list 15 compounds that may be suitable flavour reference standards after further study.

It is recognized that terminology will change with usage and the results of research and so the system should be brought up to date every few years. Individual breweries may well use other terms which help to characterize their beers. Lee *et al.* (2001) have presented a revised flavour wheel for use with whiskies.

Brown and Clapperton (1978b) examined the terms used to describe ale flavours by multi-dimensional scaling – a technique of grouping like characters together and arranging these groups relative to each other by their degree of 'similarity'. Such correlations cannot be perfect and deviations from the model are expressed as 'stress'. Thus the seven after-flavour terms (sweet, toffee-like, caprylic, burnt, astringent, and mouthcoating) can be represented in a two-dimensional model with only 0.3% stress. In contrast for odour and flavour terms a three-dimensional model is required and the stress value is approximately 13%. These terms fall roughly on the surface of a sphere so that

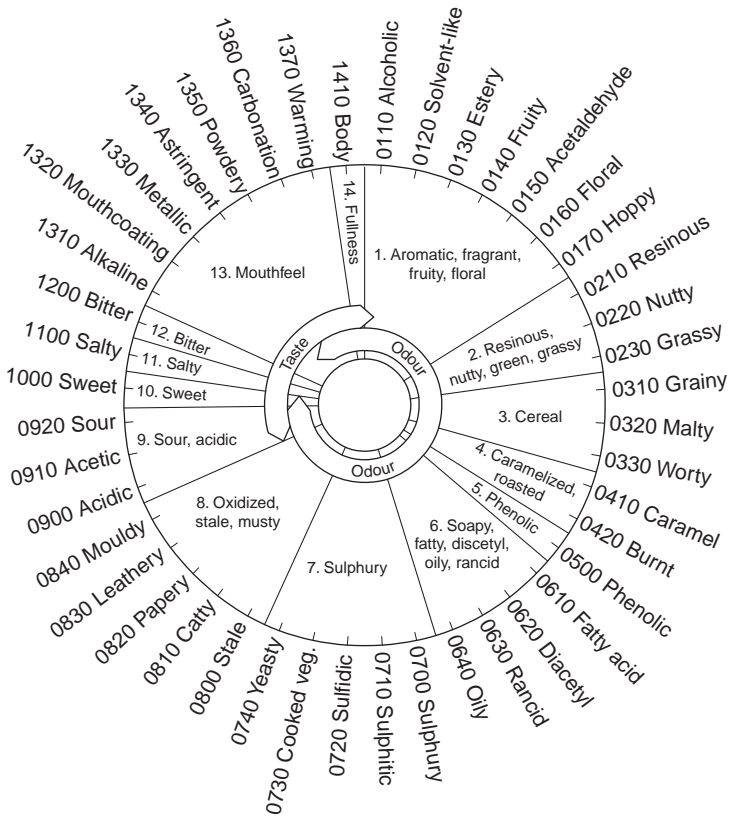

Fig. 20.22 Flavour wheel showing class terms and first-tier terms (*Analytica-EBC*).

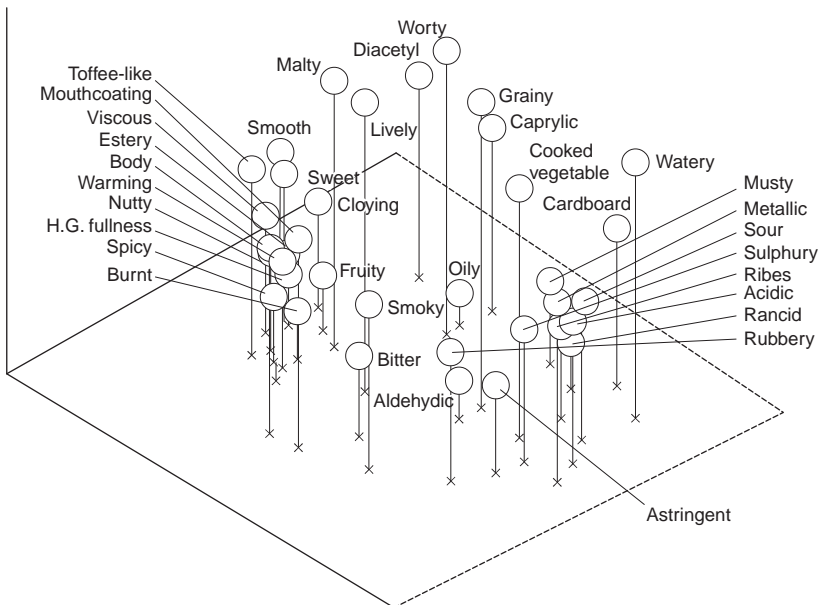

Fig. 20.23 Flavour terms by multi-dimensional scaling (after Brown and Clapperton, 1978b).

those that are close together on the model (Fig. 20.23) have a close flavour relationship, e.g. sour and acidic, whereas widely different or opposite characteristics such as sweet and bitter or body (full) and watery (thin) are further apart or at opposite points on the surface. The flavours associated with strong ales are seen on the left-hand side of the diagram (Fig. 20.23) while many of those on the right-hand side are associated with oxidative deterioration or staling of beer. Terms in the central section of the diagram, including diacetyl, caprylic, worty, grainy, lively, bitter, burnt and nutty, may be regarded as belonging to an intermediate category of flavours that are pleasant to some and unpleasant to others at their normal levels of perceived intensity in commercial beers. High levels of hop bitter substances, particularly in beers that are fermented to dryness, can impart astringency as well as bitterness to the flavour so these terms are found close together on the model.

Brown *et al.* (1974) used discriminant (cluster) analysis to examine national and regional differences in lager beers. In this technique each beer is represented as a point in multi-dimensional space, the coordinates of which are determined either by the individual flavour characteristics, determined by profile analysis, or by physicochemical parameters, determined by chemical analysis. Twenty-seven terms gave significant scores with lagers and the pattern of points in 27-dimensional space is simplified by a computer program to produce eigenvectors (mathematical devices to convert a pattern of points in multi-dimensional space into an equivalent pattern of points in a smaller number of dimensions). This has the advantage of bringing things down to a level non-mathematicians can visualize but has the disadvantage that the axes only represent mathematical abstractions and not brewing parameters. Thus, the two-dimensional pattern of North American, Continental European and British lagers gave three discrete tight clusters of points. When only the 12 highest scoring sensory characteristics were used the beers still fell into three groups but the clusters were more diffuse (Fig. 20.24). This result can be interpreted in terms of the perceived differences in bitterness, dimethyl sulphide (DMS) flavour, and palate fullness (OG). Of the flavour terms scored: (i) dimethyl sulphide and cabbage-vegetable water both relate to the DMS factor; (ii) body, warming, and high gravity fullness, and viscous relate to differences in original gravity;

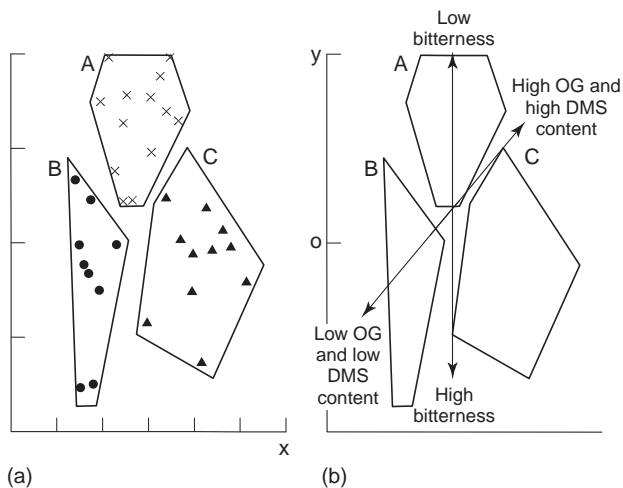

Fig. 20.24 Discriminant analysis of sensory data on thirty-three lager beers. (a) Result; (b) Interpretation of result. Code: A = North American beers, B = British beers, and C = Continental European beers (after Brown and Clapperton, 1978a).

Table 20.12 Results of cluster analysis of sensory and physiochemical data on beer (after Clapperton, 1979)

	Odour items	Physiochemical parameters	Flavour terms	
4	Estery	Original gravity Isocamyl alcohol 2-Methylbutanol Total carbohydrates Dextrins	Body Estery Fruity Viscous	1
		Potassium	Mouth coating Warming Spicy * Watery	2
		Propanol Ethyl acetate Isoamyl acetate		
		Phosphate		
		Total fatty acids Octanoic acid Decanoic acid	Caprylic	4
		Present gravity	Sweet Cloying Toffee-like * Astringent	5
		Bitterness	Bitter	9
		Sulphur	Metallic	17
12	Ribes	Air content		
16	Hoppy	Dodecanoic acid Tetradecanoic acid		

* Negatively correlated with other terms and parameters in the same cluster

and (iii) bitter, drying, and possibly smooth (mouth-feel) relate to differences in bitterness.

Brown and Clapperton (1978a) also examined 46 ales (OG 1030–1050) from five brewing companies by sensory profile analysis and by instrumental analysis. The most important variables in the discriminant analysis were: (i) isoamyl alcohol content (instrumental), (ii) caprylic flavour (sensory), (iii) sodium content (instrumental); (iv) meaty aroma (sensory), (v) ethyl acetate content (instrumental), (vi) bitter after-flavour (sensory), (vii) dextrin content (instrumental), (viii) smoky flavour (sensory), and (ix) DMS content (instrumental). On the basis of these parameters 87% of the ales were correctly assigned to their brewing company. Similarly, the ales could be assigned to their gravity band either instrumentally on the basis of alcohol or dextrin content or by sensory analysis using 13 parameters. The sensory parameters in order of importance were: (i) body, (ii) aldehyde (odour), (iii) high gravity fullness, (iv) viscous (thick), (v) estery, (vi) meaty (odour), (vii) cooked vegetable (odour), (viii) rubbery, (ix) caprylic, (x) DMS (odour), (xi) fruity, (xii) cloying, and (xiii) sour.

Clapperton (1979) also carried out another cluster analysis using both sensory terms and

physicochemical parameters and the results are given in Table 20.12, where the numbers refer to the order of formation of the clusters, i.e., the lower the number the better the correlation. Clusters which only contained sensory terms were omitted. The first two clusters isolate terms that relate to esters, alcohols and original gravity. Although there is a curious reversal of ester and alcohol contents and the corresponding flavour effect between clusters 1 and 2, estery (odour) is grouped, as expected, with ethyl and isoamyl acetate content in cluster 4. Apart from cluster 16 the clusters indicate causative relationships between the physicochemical parameters and the corresponding sensory terms.

Principal component analysis is another statistical technique that Clapperton and Piggott (1979) applied to the results of profile analysis. Ales and lagers were examined and two-dimensional plots of the results using the first two principal components as axes showed resolution of the ales from the lagers and the close proximity of duplicate samples. Piggott and Jardine (1979) used principal component analysis to differentiate various brands of whisky. Most workers in this field have excluded hedonic expressions but Moll *et al.* (1978) used principal component analysis to classify Continental European beers as good, average or poor on the basis of nine physicochemical parameters: colloidal stability (7 days at 40 °C/1 day at 0 °C), cold sensitivity (24 h at 0 °C), brightness at 12 °C, six months test, the content of β -phenylethanol, ethyl caprylate, isoamyl acetate and isobutanol and foam stability.

Hoff *et al.* (1978) used headspace analysis to determine the levels of the isoamyl alcohols, isobutanol, ethyl acetate and isoamyl acetate in beers (β -phenylethanol and ethyl caprylate are not sufficiently volatile to be measured by headspace analysis). To compare two beers, the peak areas on the chromatogram (excluding ethanol and the internal standard xylene) were expressed as a percentage of the total peak area. A chronologically updated data base was used to calculate the standard deviation for each peak and a two-tailed t-test was performed on the mean values from duplicate determinations on the two beers. These results were used to predict the results of triangular taste tests:

1. If none of the peaks is significantly different between samples at 0.005 risk, one predicts that the tasting panel results will be insignificant at 0.05 risk.
2. If one or more peaks are significantly different between samples at 0.001 risk, one predicts that the panel results will be significant at a risk of 0.05 or less.
3. If one or more peaks are significantly different between samples at 0.005 risk but insignificant at 0.001 risk, no prediction is made and the sample number increased.

The taste panel found 200 significant results out of the 234 predicted and 70 insignificant results out of the 76 predicted and it was suggested that tastings could be reduced by eliminating samples that were similar by headspace analysis. However, it was acknowledged that differences due to sulphur compounds, staling or certain hop compounds may go undetected. Nevertheless the headspace/statistical method predicted and the tasting panel found significant differences between beers produced at three branch plants.

Compared to chemical assays, flavour results from human assessors have been regarded as unreliable but Hegarty and White (1993) have applied two-way analysis of variance (ANOVA) statistics to the results of a flavour profile panel. This can establish the degree of variability due to assessor differences, the degree of variability due to differences between samples and the amount of variability that cannot be explained ('noise'). Results can be expressed as the F-ratio (Fisher ratio) which, if large, shows a significant difference. Thus, ideally, the F-ratio for the assessors should show a low value indicating that the score attributed to a given sample does not vary greatly between

tasters. This approach can be expanded to monitor the performance of individual assessors. The mean score can show whether the assessor is scoring high or low relative to the rest of the group. The standard deviation is a measure of scoring consistency and the F-ratio indicates whether the assessor can distinguish samples consistently. The statistics showed that tasters do not perform equally on all characters. The key to reliable flavour results is on-going performance monitoring and on-going flavour training.

20.5 References

- ACREE, T. E. and TERANISHI, R. (eds) (1993) *Flavor Science – Sensible Principles and Techniques*. American Chemical Society, Washington DC. pp. xvi + 352.
- AKABAS, M. H., DODD, J. and AL-AWQATI, Q. (1988) *Science*, **242**, 1047.
- AMERICAN SOCIETY FOR TESTING AND MATERIALS (1979) *Standard practice for Determination of Odour and Taste Thresholds by Forced Choice Ascending Concentration Series*. E 67979. ASTM, Philadelphia, PA.
- AMERINE, M. A., PANGBORN, R. M. and ROESSLER, E. B. (1965) *Principles of Sensory Evaluation of Food*. Academic Press, New York.
- AMOORE, J. E. (1991) in *Smell and Taste in Health and Disease* (ed. Getchell, T. V. et al.) p.655.
- BOUDREAU, J. C. (ed.) (1979) *Food Taste Chemistry*. ACS Symposium No. 115. American Chemical Society, Washington DC, 262pp.
- BRESLIN, P. A. S. (2001) *Flavour Fragr. J.* **16**, 439.
- BROWN, D. G. W. and CLAPPERTON, J. F. (1978a) *J. Inst. Brewing*, **84**, 318.
- BROWN, D. G. W. and CLAPPERTON, J. F. (1978b) *J. Inst. Brewing*, **84**, 324.
- BROWN, D. G. W., CLAPPERTON, J. F. and DALGLIESH, C. E. (1974) *Proc. Annu. Meet. Am. Soc. Brew. Chem.*, p. 1.
- BROWN, D. G. W., CLAPPERTON, J. F., MEILGAARD, M. C. and MOLL, M. (1978) *J. Amer. Soc. Brew. Chem.*, **36**, 73.
- CHEVANCE, F., GUYOT-DECLERCK, C., DUPONT, J. and COLLIN, S. (2002) *J. Agric. Food Chem.*, **50**, 3818.
- CLAPPERTON, J. F. (1974) *J. Inst. Brewing*, **80**, 164.
- CLAPPERTON, J. F. (1976) *J. Inst. Brewing*, **82**, 175.
- CLAPPERTON, J. F. (1978) *J. Inst. Brewing*, **84**, 107.
- CLAPPERTON, J. F. (1979) in Land, D. G. and Nursten, H. E. *Progress in Flavour Research*. Applied Science Publishers, London, p. 1.
- CLAPPERTON, J. F. and BROWN, D. L. W. (1978) *J. Inst. Brewing*, **84**, 90.
- CLAPPERTON, J. F. and PIGGOTT, J. R. (1979) *J. Inst. Brewing*, **85**, 271.
- DALGLIESH, C. E. (1977) *Proc. 16th Congr. Eur. Brew. Convn. Amsterdam*, p.623.
- DE COOMAN, L., AERTS, G., OVERMEIRE, H. and DE KEUKELEIRE, D. (2000) *J. Inst. Brewing*, **106**, 169.
- DELWICHE, J. F., BULETIC, Z. and BRESLIN, P. A. S. (2001) *Perception and Psychophysics*, **63**, 761.
- DOTY, R. L. (ed.) (1995) *Handbook of Olfaction and Gustation*. Marcel Dekker, New York.
- EVANS, D. J., SCHMEDDING, D. J. M., BRUIJNJE, A., HEIDEMAN, T. and KING, B. M. (1999) *J. Inst. Brewing*, **105**, 301.
- FERNANDUS, A., OOSERAM-KLEIJNGELD, I. and RUNNEBOOM, A. J. M. (1970) *Tech. Quart. MBBA*, **7**, 210.
- GARDNER, R. J. (1978) *J. Pharm. Pharmacol.*, **30**, 351.
- GARDNER, R. J. (1979) *Tech. Quart. MBAA*, **16**, 106, 148, 204.
- GIENAPP, E. and SCHRÖDER, K. L. (1975) *Die Nahrung*, **19**, 697.
- GIJS, L. and COLLIN, S. (2002) *J. Amer. Soc. Brew. Chem.*, **60**, 68.
- GIJS, L., PERPÈTE, P., TIMMERMANS, A. and COLLIN, S. (2000) *J. Agric. Food Chem.*, **48**, 6196.
- GIJS, L., CHEVANCE, F., JERKOVIC, V. and COLLIN, S. (2002) *J. Agric. Food Chem.*, **50**, 5612.
- GIVEN, P. and PARADES, D. (eds.) (2002) *Chemistry of taste – Mechanisms, Behaviors and Mimics*. ACS Symposium No. 825. American Chemical Society, Washington, DC.
- GOIRIS, K., DE RIDDER, M., DE ROUCK, G., BOEYKENS, A. VAN OPSTAELE, F., AERTS, G., DE COOMAN, L. and DE KEUKELEIRE, D. (2002) *J. Inst. Brewing*, **108**, 86.
- GOODE, J. (2003) *Wine Magazine*, April, 2003, p.44.
- GOODENOUGH, P. W. (1998) *Int. J. Food Sci.*, **33**, 63.
- GRAY, P. P. and STONE, I. (1939) *J. Inst. Brewing*, **45**, 253.
- GUADAGNI, D. G. (1970) quoted by Teranishi, R. in Ohloff, G. and Thomas, A. F. (eds) (1971) *Gustation and Olfaction* Academic Press, New York, p. 170
- HEGARTY, P. K. and WHITE, F. H. (1993) *Proc. 24th Congr. Eur. Brew. Convn. Oslo*, p.429
- HEGARTY, P., CHILVER, J. and THREAPLETON, L. (2001) *Proc. 28th Congr. Eur. Brew. Convn. Budapest* Paper 89.
- HOFF, J. T., CHICOYE, E., HERWIG, W. C. and HELBERT, J. R. (1978) in Charalambous, G. (ed.) (1978)

- Analysis of Foods and Beverages Headspace Techniques*, Academic Press, New York, p. 187.
- HOUGH, J. S. (1990) in *An Introduction to Brewing Science and Technology. Series II, Volume 3. Quality*. Institute of Brewing, London.
- HUGHES, P. S. and BOLSHAW, L. H. (1995) *Proc. 25th Congr. Eur. Brew. Conv. Brussels*, p. 151.
- INSTITUTE OF BREWING (1995) *Sensory Analysis Manual*, 44 pp.
- INTERNATIONAL ORGANIZATION FOR STANDARDIZATION (1983) *International Standard 6658. Sensory Analysis, Methodology, General guidance*. ISO, Paris.
- JONES, F. N. (1956) *Amer. J. Psychology*, **69**, 672.
- KANEDA, H., KANO, Y., KOSHINO, S. and OHYA-NISHIGUCHI, H. (1992) *J. Agric. Food Chem.*, **40**, 2102.
- KANEDA, H., SHINOTZUKA, K., KOBAYAKAWA, T., SAITO, S. and OKAHATA, Y. (2001) *J. Amer. Soc. Brew. Chem.*, **49**, 167.
- KANEDA, H., WATARI, J., TAKASHIO, M. and OKAHATA, Y. (2003) *J. Inst. Brewing*, **109**, 27.
- KIER, L. B. and HALL, L. H. (1976) *Molecular Connectivity in Chemistry and Drug Research*. Academic Press, New York.
- LACAN, F., SOULET, S., ARNAUDINAUD, V., NAY, B., VERGÉ, S., CASTAGNINO, C., DELAUNAY, J.-C., CHÈZE, C. and VERCAUTEREN, J. (2000) *Cerevisia*, **25** (4), 35.
- LANGSTAFF, S. A. and LEWIS, M. J. (1993) *J. Inst. Brewing*, **99**, 31.
- LAWLESS, H. and HEYMANN, H. (1999) *Sensory Analysis of Foods: Principles and Practice*. Kluwer/Plenum, New York.
- LEE, K.-Y. M., PATTERSON, A., PIGGOTT, J. R. and RICHARDSON, G. D. (2001) *J. Inst. Brewing*, **107**, 287.
- LERMUSIEAU, G., NOËL, S., LIÉGEIS, C. and COLLIN, S. (1999) *J. Amer. Soc. Brew. Chem.*, **57**, 29.
- LEWIS, M. J., PANGBORN, R. M. and FUJII-YAMASHITA, J. (1980) *Proc. 16th Conv. Australian and New Zealand section of the Institute of Brewing, Sydney*, p. 165.
- MACKIE, A. E. and SLAUGHTER, J. C. (2002) *J. Inst. Brewing*, **108**, 336.
- MALEK, D. M., SCHMIDT, D. J. and MUNROE, J. H. J. (1982) *J. Amer. Soc. Brew. Chem.*, **40**, 133.
- MEILGAARD, M. C. (1975) *Tech. Quart. MBAA*, **12**, 107, 151.
- MEILGAARD, M. C. and REID, D. S. (1979) in Land, D. G. and Nursten, H. E. (eds) *Progress in Flavour Research*. Applied Science Publishers, London, p. 67.
- MEILGAARD, M. C., CIVILLE, G. V. and CARR, B. T. (1987) *Sensory Evaluation Techniques*. CRC Press, Boca Raton FL.
- MOLL, M., VINH, T. and FLAYEUX, R. (1978) in Charalambous, G. (ed.) *Flavours of Foods and Beverages – Chemistry and Technology*. Academic Press, New York, p. 329.
- MONTMAYEUR, J. P. and MATSUNAMI, H. (2002) *Current Opinion in Neurobiology*, **12**, 366.
- NIEMAN, C. (1960) quoted in Amerine, M. A., Pangborn, R.M. and Roessler, E. B. (1965) *Principles of Sensory Evaluation of Food*. Academic Press, New York, p. 95.
- NOËL, S., METAIS, N., BONTE, S., BOPART, E., PELADAN, F., DUPIRE, S. and COLLIN, S. (1999) *J. Inst. Brewing*, **105**, 269.
- OHLOFF, G. (1994) *Scent and Fragrances – The Fascination of Odours and their Chemical Perspectives*. Springer Verlag, Berlin, pp. xii + 238. Translated from the German *Riechstoffe und Geruchssinn* (1990) by Pickenhagen, W. and Lawrence, B. M.
- PANGBORN, R. M. (1959) *Amer. J. Clin. Nutrition*, **7**, 280.
- PANGBORN, R. M. (1980) in Koivistoinen, P. and Hyvönen, L. *Carbohydrate Sweeteners in Food and Nutrition*, Academic Press, New York, p. 87.
- PERPÈTE, P. and COLLIN, S. (1999) *J. Agric. Food Chem.*, **47**, 2374.
- PIGGOTT, J. R. (ed.) (1988) *Sensory Analysis of Foods*. 2nd edn, pp. x + 422. Elsevier Applied Science, London.
- PIGGOTT, J. R. and JARDINE, S. P. (1979) *J. Inst. Brewing*, **85**, 82.
- RICHTER, C. P. and MacLEAN, A. (1939) *Amer. J. Physiol.*, **126**, 1.
- ROESSLER, E. B., PANGBORN, R. M., SIDEL, J. L. and STONE, H. J. (1978) *Food Science*, **43**, 940.
- ROUSEFF, R. L. (ed.) (1990) *Bitterness in Foods and Beverages*. Elsevier, Amsterdam, pp xviii + 356.
- SMYTHE, J. E., O'MAHONY, M. A. and BAMFORTH, C. W. (2002) *J. Inst. Brewing*, **108**, 37.
- SWAIN, T. and CASEY, J. C. unpublished results quoted in Reynolds, T. M (1963) *Adv. Food Research*, **12**, 1.
- TEETER, J. H. and GOLD, G. H. (1988) *Nature*, **331**, 298.
- TORLINE, P. A., DERCKSEN, A. W., AXCELL, B. C. and JOHNSTONE, W. (1999) *Proc. 7th Conv. Inst. Brewing Africa Section, Nairobi*, p. 50.
- TRESSL, R., BAHRI, D. and KOSSA, M. (1980) in Charalambous, G (ed.) *The Analysis and Control of Less Desirable Flavours in Foods and Beverages*. Academic Press, New York, p. 293.
- UCHIDA, M. and ONO, M. (1999) *J. Amer. Soc. Brew. Chem.*, **57**, 145.
- VAN DER HEIJDEN, A. (1993) in Acree, T. A. and Teranishi, R. (eds) *Flavor Science – Sensible Principles and Techniques*. American Chemical Society, Washington, DC, p. 67.
- VAN OEVELEN, D., DE L'ESCAILLE, F. and VERACHTERT, H. (1976) *J. Inst. Brewing*, **82**, 322.
- WEISS, A., SCHÖNBERGER, CH., MITTER, W., BIENDL, M., BACK, W. and KROTTENTHALER, M. (2002) *J. Inst. Brewing*, **108**, 236.

21

Packaging

21.1 Introduction

Beer must be packaged before it is sold. To ensure the best possible quality of the product, packaging must be carried out with skill and care. Only if packaging is effectively performed will the product be acceptable. Beer can be put into a number of packages. The most important world-wide is the bottle. Bottles are of two types: returnable and non-returnable. The most used is the returnable bottle but in developed markets in Europe and the USA the non-returnable bottle is prevalent. Beer is also filled into cans, kegs and casks. Usually a distinction is made between draught beer, i.e., in kegs or casks and 'small-pack beer' in bottles and cans. There are differences between countries in the relative proportions of different packages (Table 21.1). The UK and Ireland are unusual in having most of their beer on draught. The UK is further unusual in that of the 64% of its beer sold on draught in 1998, 11% was conditioned in the cask and not filtered in the brewery. Cask conditioned beer demands very different packaging from keg beer.

In the mature beer markets of Western Europe, Australia and the USA sales of beer in recent years have shown little total growth. In the UK there has been a decline of about 1% per annum for the last ten years. This has resulted in product differentiation efforts being focused on packaging, particularly on small pack beers. This has coincided with an increase in beer consumed at home with the consequent domination of this trade by supermarket groups.

Packaging is influenced by environmental issues, which are stronger in some countries than others. In some cases a revival in the use of returnable glass bottles and the outlawing of selling beer in cans has occurred. Most countries now have packaging legislation, which seeks to control the use of packaging material and to reduce waste. This sometimes leads to conflict with marketing where packaging plays such a huge role in product attractiveness. Packaging is the most labour-intensive part of the brewing process. The machinery for packaging beer has become progressively more complex with the object of reducing labour costs and preserving product quality. Capital employed in packaging is usually the highest of the brewing operations. The efficiency of operation of packaging machinery is of critical importance to a profitable brewery.

Table 21.1 Relative proportion of beer sold in draught and small-pack form for important beer-producing countries in 2000 (BLRA, 2002)

Country	Production (*000hl)	Draught sales (%)	Small-pack sales (%)
USA	233,521	9	91
China	220,485	5	95
Germany	110,429	19	81
Brazil	82,600	1	99
Japan	71,727	16	84
UK	55,729	62	38
The Netherlands	25,072	30	70
Czech Republic	17,924	46	54
Australia	17,326	24	76
Ireland	8,710	78	22
Denmark	7,460	11	89

It is essential to keep records of packaging operations. These relate to the strength and type of the beer packaged and to the volume of the beer. Everywhere there is legislation governing the contents of the beer in the package for sale. This may relate to average or to a guaranteed minimum content. The records will be audited by officials. In most countries a tax (excise duty) is taken relating to the strength of the beer. The packaging department or warehouse keeps the records on which this is based (Chapter 22).

Packaging is thus of fundamental importance in the supply of beer and is pivotal in ensuring the customer is satisfied in terms of quality, quantity and legality. The preparation of beer for packaging was discussed in Chapter 15. The packaging options available, particularly for bottles and cans, are now numerous and involve different types of multi-pack presentation using cardboard and plastic. Brands can establish an identity based on the package alone and this is frequently as important as the identity created by the taste of the beer. This chapter deals with the underlying principles of successful modern packaging operations.

21.2 General overview of packaging operations

A packaging line is a series of machines designed to fill containers with beer and present those containers (packages) to the warehouse. The detailed design of the line will depend on the type of package (bottle, can, keg, or cask), the required rate of packaging and the types of beer to be packaged. There will also be machines to deal with any secondary packaging required which is usually specified by the customer.

Modern small-pack beer fillers operate at very high rates, bottling at over 1000 bottles/min. and canning at 2000 cans/min. is common. As there is little storage space in breweries for empty cans and bottles a constant stream of bottles or cans to the site is needed. This could mean around 30 vehicles/24 h carrying 26 pallets of empty containers arriving at the brewery. Manufacturers of packages are frequently located near to the packaging plant. The pressure to supply is not so intense with returnable bottles and kegs but the recovery of empties from the trade must be arranged. These logistics (Chapter 22) are very important in the management of packaging.

Two separate flows must be dealt with in any packaging plant: the flow of the beer and the flow of the containers both empty and full. Thus the mechanical engineering of machinery with large moving parts and its proximity to a perishable foodstuff must be considered. The handling of the container as well as the handling of the beer must be

optimized. Three main aspects characterize all successful packaging operations:

- Preventing air getting into the beer is essential. All the precautions followed in producing bright beer must be maintained. Probably the final product specification for dissolved oxygen in the beer will be < 0.2 mg/l or, in some cases, < 0.1 mg/l, so during filling operations the pick-up of oxygen must not exceed 0.02–0.03 mg/l. If this oxygen level is not achieved serious flavour deterioration will result. This control of oxygen is therefore a major feature of good packaging. Control of oxygen on filling is not important with casks. Cask beer contains live yeast (1–4 million cells/ml) for secondary fermentation and any oxygen present in the beer is rapidly scavenged by the yeast.
- The temperature of the beer after conditioning and on filling the bright beer tank is likely to be -1 to 0°C (30 – 32°F) and the carbon dioxide content may be 2.1–2.7 volumes depending on whether it is destined for keg or small pack. The pressure on the beer must be maintained and the temperature rise controlled to $< 2^{\circ}\text{C}$ (3.5°F) to keep carbon dioxide in solution. Carbon dioxide loss is a serious problem, which can disrupt beer supply as beer is held in the warehouse pending re-processing. This is expensive and potentially damaging to customer service.
- The final major factor common to all filling plants is cleanliness. All the plant, not just that in contact with the beer, must be regularly and thoroughly cleaned.

21.3 Bottling

Worldwide most beer is drunk from bottles, either returnable or non-returnable. The filling of these bottles is essentially the same. The difference in equipment needed relates to the handling of the used and returned empty bottles and washing them prior to filling. Many of the principles of successful bottling apply equally to canning, and to some extent, to kegging. Details will be discussed in this section on bottling and differences highlighted in the sections on canning and kegging.

A successful bottling line should allow the brewer to:

- maintain the dissolved oxygen level in the beer to at least < 0.2 mg/l, although there are now reports of plant able to meet a specification of < 0.05 mg/l (Parsons, 2000)
- ensure the beer is supplied to the customer containing no viable micro-organisms
- operate with the minimum number of stoppages to keep losses to $< 1.5\%$ of the total brewery loss and lower the headspace air content to $< 2\text{ml/l}$ and provide the highest efficiency.

The bottling line consists of a series of machines and processes:

- depalletizer
- decrater
- washer
- empty bottle inspection
- flash pasteurization or sterile filtration
- filler
- crowner
- tunnel pasteurization
- full bottle inspection
- labeller

- crater
- palletizer
- cleaning

If the beer is flash pasteurized or sterile filtered then the subsequent operations must be aseptic. The flow of the beer relates to filling and, if in use, sterile filling or flash pasteurization. All the other machines are associated with the flow of containers both full and empty. Normally there is a system for in-place cleaning (CIP) that is naturally more rigorous when sterile filling is being used. The most important machine is the filler and to satisfy the criteria above this must operate with the minimum of stops and on a given run of product, operate continuously. Storage capacities before and after the filler must be designed to allow continuous filling. This can take up a lot of space. If the efficiency of the filler is taken as 100% then the machines on either side associated with container flow must have operational capacities of 110–140% to ensure uninterrupted filling.

21.3.1 Managing the bottle flow

The flow of containers has to be managed before and after filling and labelling. We are concerned with: depalletizing; decrating; washing or rinsing; empty bottle inspection; full bottle inspection; labelling; crating or other secondary packaging; palletizing. Packaging is labour intensive. The numbers of people employed have been reduced by automation and by careful planning of the layout of the machinery. This must take account of the organization of the warehouse for the receipt of full and empty goods. The number of work stations on the packaging line should be minimized and hence the numbers employed in the packaging department should be reduced. The machines involved in palletizing and crating of full containers and depalletizing and decrating of empty containers are similar in principle. To reduce labour involvement they must be located together to form one work station (Fig. 21.1). This type of organization has allowed a productivity of 0.2 million hl/year/person in a Japanese bottling hall operating at 72,000 bottles/h (Yokoi *et al.*, 1991). Improvements on this figure are now being achieved.

Bottling of returnable bottles involves receiving crates of dirty bottles on pallets separating the crates from the pallets and the bottles from the crates and then washing the empty bottles. Bottling into non-returnable bottles involves receiving new glass bottles, which only require rinsing not the thorough cleaning associated with washing dirty bottles.

Depalletizing and palletizing

Palletizers and depalletizers are normally closely situated and operated by one man. The machines must interface with forklift trucks in the warehouse. The efficient operation of these machines is critical to overall efficiency of the line. They are normally capable of working at rates of $1.4 \times$ filling rate (filling = 1). Dirty returnable bottles are usually received at the brewery in crates. New glass bottles for the non-returnable trade are received on cardboard trays. These crates or trays are most frequently formed onto pallets, which can be wooden in which case there are layers of crates built onto the pallet or there can be plastic spacer boards separating layers of crates or trays. Plastic spacer boards are less robust than wooden pallets but are lighter and take up less space.

The depalletizer removes the crates or trays and presents them to the decrating machine. This is achieved by a lifting device fixed to a frame holding a loading head. The loading head loads or unloads the whole layer at once. Lifting heads can be complex and

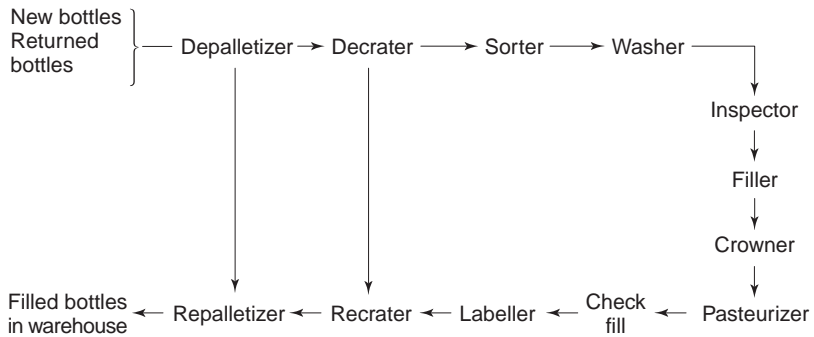

Fig. 21.1 Arrangement of equipment in a bottling hall (Hough *et al.*, 1982).

can use clamps or hooks to effect the lift. A mixture of pneumatic or hydraulic rams and electric motors provides motive force. Position sensing uses micro-switches or photo-electric cells. The machine is complex and requires regular maintenance to ensure efficient operation. These machines must be working to design criteria to ensure overall line efficiency. Removal of the spacer board can be effected mechanically but these machines have to locate the position accurately and repetitively and this does not always happen resulting in much frustration. It is often decided, therefore, to remove the spacer board or the pallet manually. Obviously the machines involved in palletizing and depalletizing are identical but operating in the alternative mode.

Decrating and crating

Having disassembled the crate or tray the bottles must now be removed and presented to the next machine in the line, the washer. The crating operation at the other end of the line will need a machine but depending on the detail of the type of package it may operate differently from the decrater. Removal or packing of bottles is effected by 'gripper heads' mounted on a frame. For efficiency these machines should function at $1.25 \times$ filling (filling = 1). The machines can operate in a batch format or continuously. The choice should be made with reference to the efficiency obtained. These machines have many moving parts and need considerable maintenance. Machines that work continuously are less widely used in breweries because different bottle sizes require setting changes. In continuous machines the gripper heads run along a track in a synchronous movement and are constantly lowered or raised to deal with the constantly moving crates. In the batch process the bottles are removed or placed in the crate in a discrete step, as the crate is stationary. Either system will work effectively.

Secondary packaging

Returnable bottles are generally sold for consumption in bars and other licensed premises. As such the bottles are supplied in crates. The crate is not displayed to the customer and therefore has no marketing significance. Non-returnable bottles are sold for consumption at home. These are frequently bought through supermarkets where there is scope for elaborate secondary packaging using cardboard containers, which can display the brand logo and colours to the purchaser. Secondary packaging is arranged to present the bottles in a variety of 'multi-packs' to satisfy the customer and the marketing department. Thus bottles can be packed in sleeves of 1×4 , 2×2 , 2×3 , or 2×5 combinations (Parsons, 2000; Wainwright, 1999). These clusters can then be packed into final packages of 8, 12,

15, 18, 20 or 24 bottles. Corrugated or plain cardboard is used and shrink-wrapping can be added for final protection. The possibilities of multi-packing are almost endless. It is in this area of the business that most expenditure on research and development is now made. This is a very important part of the fight for brand supremacy.

Washing

This is a critical part of returnable bottling. Bottles return to breweries in various states, they will be dirty and will still have labels attached. The labels may be made of paper or metallized foils, which may contain tin or aluminium. Bottle cleaning must remove all the labels, and clean and sterilize the bottles, which are then presented to the filler. This is an aggressive operation and over time the bottles will become scuffed and unattractive. This has been a problem in developed markets where the appearance of the package is so important. This has led to the rise in popularity of the one-trip non-returnable bottle, which can be decorated to a very high standard. This type of package, unless re-cycled, is less environmentally acceptable than the returnable bottle.

Important factors in all bottle washers are:

- soaking to remove dirt and labels
- jetting to rinse
- temperature
- strength of detergent, which is normally alkaline.

The total time of the operation is normally 10–15 minutes. The sequence of operations varies with different washers. A typical system is to soak the dirty bottles in hot water and then pass them through a hot caustic soda solution. Bottles are then successively rinsed with hot caustic solution, hot water, and finally cold fresh water. Bottles are transported through the machine in rows of perhaps 50–70. The bottles are assembled in lines so that they cannot fall over. Efforts are made to keep the noise as low as possible (< 85 dBA). Propulsion is usually by a slat conveyor chain. In outline we have:

- Soaking. Residues of beer are drained at the first station in the machine (Fig. 21.2). There is then usually a pre-soak at 35–40 °C (95–105 °F) to remove easily soluble dirt and to pre-warm the bottles. The bottles are then immersed in a bath of caustic soda solution (2.0 to 3.5%) at 75–85 °C (165–185 °F). Residence time is extended by circulating the bottles in a series of loops. The caustic solution is then jetted over the bottles to remove any remaining labels. The effluent solution from these operations is very dirty and contaminated with micro-organisms.
- Rinsing/jetting. After soaking, the bottles are rinsed neck downwards several times with hot caustic solution, hot water and cold water. The temperature of the caustic solution is 45 °C (115 °F), the hot water is 35 °C (95 °F) and the cold water is 20–25 °C (68–77 °F). The final fresh water rinse will be at around 15 °C (60 °F). Washers are complex (Kunze, 1999).
- Label disposal. The major challenge of the operation is the removal of the soggy mass of denatured label paper and foil. A label press is used to dewater the label pulp by about 80% and the caustic solution residue is returned to the bottle washer. Disposal of the 'dry' pulp is not always easy; it usually goes to landfill or to incineration.
- Detergent. The detergent is normally based on 1% w/v sodium hydroxide solution. It must have good wetting power to penetrate the old labels and should not cause foam or allow scale build-up. Microbes must be killed. Water with low temporary hardness

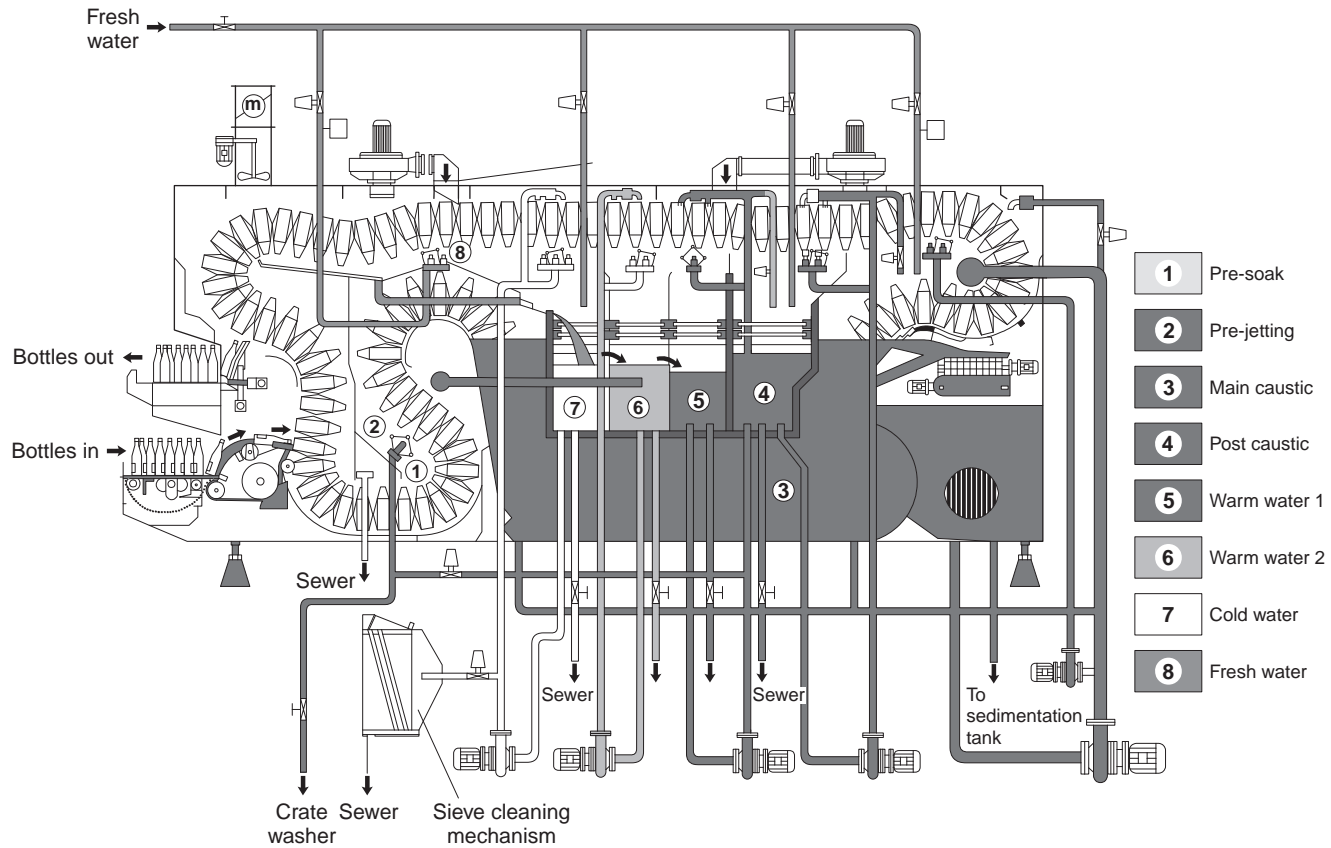

Fig. 21.2 Bottle-washing machine (by courtesy of Kronen).

must be used to prevent the deposit of calcium carbonate scale. Acid scale preventing additives and chelating agents such as gluconates are added to the rinsing zones to keep calcium in solution and phosphates are added as wetting agents. Aluminium in some foil labels releases hydrogen gas from the caustic solution. This must be vented from the washer. About 90% of the caustic solution can be used again without treatment as it is only lightly contaminated. However, about 10% of the solution is heavily contaminated with paper, colloids, colour pigments, label adhesives, metal salts and oils. The solids are usually removed by settling in an insulated tank. If bottling is being performed on a two-shift basis (up to 16 h/day) this settling can be carried out overnight. If settling is carefully performed then the detergent can last for very long times in the bottle washer.

Caustic bottle-washing solutions are slowly corrosive to glass bottles. This causes dissolution of soda lime glass by etching. Scuffing also occurs by the physical abrasion of the bottles as they rub together on the line, causing visible wear rings on the shoulder and base of each bottle. This results in a population of etched, scuffed bottles, which cannot display the beer to its best effect. This also applies to the ceramic labels, which are sometimes applied directly to the glass. Detergents have been formulated to reduce the etching and so to enhance the life and appearance of bottles (Rouillard, 1999; Rouillard and Howell, 1999). It is anticipated that reduced etching will result in reduced scuffing, as the glass is stronger.

EDTA and phosphates present in caustic bottle-washing solutions accelerate corrosion of the glass (Rouillard and Howell, 1999). A corrosion inhibitor (Divobrite Integra) has been shown to reduce etching to an extent that the appearance of a bottle after 30 trips was equivalent to that after 15 trips following the use of a conventional bottle-washing detergent containing EDTA and phosphate. This work is important because the returnable bottle is environmentally friendly but its use is limited by the intense demand for a 'perfect' package, which the returnable bottle cannot be.

Rinsing

Retailing of small pack beer is intensely competitive. Marketing departments have sought to gain competitive advantage for their beers with extreme differentiation of the package (see 'secondary packaging' above). The non-returnable one-trip bottle is well suited for this. The brand image can be protected and enhanced by a 'perfect' package. Much of this beer is sold in large retail chains for consumption at home. Recognition of the product on the supermarket shelf is vital to success. Non-returnable bottles are displayed in a wide variety of attractive secondary packaging for this purpose.

Non-returnable bottles are delivered new to the brewery. They are normally rinsed by spraying inside and outside several times. For rinsing the bottles are turned upside down and then returned to the upright position for filling. Rinsers are now almost integral with the filling machine. The process is designed to wet the bottles prior to filling and to ensure sterility by killing micro-organisms. Steam is usually jetted into the bottle for this purpose followed by a purge of sterile air. This results in 0.1 to 0.2 ml of condensate remaining in the bottle.

Empty bottle inspection

A bottler of beer must demonstrate due diligence in providing a quality and wholesome product. He must also run his bottling plant at the highest efficiency possible consistent with supplying that quality product. The bottles presented to the filler must be 'fit to fill'.

The bottles must not contain any foreign bodies or in the case of returnable bottles, any residual caustic solution from the washer. Defective bottles with damaged necks must be sorted and removed. They may be fillable but could cause damage to the filling machine or result in the beer being presented in an unacceptable package. Inspection of empty bottles prior to filling is therefore an important process. Originally this inspection was done by eye but with the very high rate of modern bottle fillers ($> 1,000$ bottles/min) the process is now performed electronically. Frequently used systems (Kunze, 1999) employ very high speed cameras (picture-taking speeds of $1/250,000$ s) to look for defects. Examinations are made of internal and external sidewalls and the base and neck of the bottle. Residual liquid is detected by infra-red radiation from beneath the bottle. Defective bottles are rejected. For returnable bottles this can mean rejection rates of 2% of the total bottles returned. In an ageing bottle population this rate could be higher.

Full bottle inspection

There are two reasons for inspecting full bottles: to check the volume of beer in the bottle, and to check for foreign particles. These processes are necessary no matter how careful is the empty bottle inspection and the filling. Usually there is a legal requirement to guarantee minimum or average contents of the bottle. Inspection systems normally involve passing a beam of white light or radiation through the bottle at a defined level. Bottles not meeting the fill level required are rejected. This process is often repeated after tunnel pasteurization. Off-line checks are also required and records must be kept for inspection by government agents.

Some beers can now be described as global brands. The brand can be brewed and packaged in many countries. In this situation the quality and consistency of the beer is vital for continuing success. Sometimes it is necessary to introduce on-line checks for foreign particles including glass fragments in the bottled beer (Landman, 1999) to further safeguard product integrity and wholesomeness. The principle of one machine is to spin the bottle thus suspending any foreign bodies then quickly to stop the bottle leaving the beer and any unwanted particles spinning. The spinning beer is then examined optically using a computerized video camera. If differences between consecutive images are found, indicating contaminating particles, the bottle is rejected. The bottle inspecting device is a rotating carousel holding 36 bottles. Each bottle has a dedicated camera that moves with the bottle and takes multiple pictures as the carousel rotates. The computer detects moving particles against a stationary bottle. Particles of below 1 mm in size can be detected. This type of full bottle inspection provides the consumer with near absolute protection against foreign bodies and the brewer is provided with further enhancement of brand image.

Labelling

Managing the flow of bottles is needed before and after filling. Managing the flow of beer is concerned with the filling and closing operation and rendering of the beer free from micro-organisms. Labelling of the bottle can be considered as part of the management of the bottle flow. In the sequence of operations labelling follows full bottle inspection, which may itself have been preceded by tunnel pasteurization. Labelling is of major significance in the presentation of the beer brand. The label not only tells the drinker what the beer is but also conveys an image associated with advertising that adds to the overall appeal of the brand. This is particularly the case with international beer brands where instant identity of the brand in different countries is important. The application and the quality of the label must now be of the highest standard. Poor quality or poorly applied labels will imply a poor beer.

- The label. Every bottle of beer has at least one label, but frequently several labels are applied. These can be applied to the body, back and neck of the bottle. In addition foil or plastic capsule tops can be applied over the crown. The function of the label is twofold: the legislative information required in the country in which the beer is being sold must be displayed and the brewer must display the logo and colour detail associated with the brand. The legal data may include a statement of the volume of the beer in the bottle and its strength and may in some countries include a statement of the ingredients. Frequently the shelf-life of the beer must be shown. There are many different types of paper used for labels; this number has increased with the popularity of metallized paper labels. There are some basic properties of label paper that can be described in terms of stiffness, weight, smoothness, density, behaviour in caustic soda solutions, curl characteristics, etc. (Schwartz, 1997).

Originally label paper was resistant to the caustic soda solution used in the bottle washer for returnable bottles. This allowed the label to be removed without forming a pulp that is difficult to dispose of and, indeed, in some countries its disposal is prohibited. In other countries (USA and UK) alkali soluble paper is now used and pulp disposal is allowed. Label paper should be resistant to curling and creasing and often the reverse side is treated with a pigment to prevent this happening when the front side is coated to receive the pigments and metallized effects. The orientation of the grain of the paper in relation to the bottle surface is important. The fibres in the bottle label should run at right-angles to the longitudinal axis of the bottle. If the fibres run parallel then the labels will tend to come away from the bottles at the edges, a phenomenon known as 'flagging'.

The different types of paper in use can be divided into three categories: paper, metallized paper, and aluminium foil. The paper is usually designated by its weight per ream, which in the USA contains 480 or 500 sheets. Paper for paper labels is normally of 40 to 50 lb. (18–23 kg). The surface of an aluminium foil label is 99.5% pure aluminium at a thickness of 0.009 mm. When applied to paper the overall thickness is only 0.09 mm, hence very specialized machinery is needed to produce these labels for application to the bottle. Aluminium foils are often used for neck labels. The metallized paper label is formed by the vacuum deposition of an ultra-thin layer of metal on a paper to achieve a 'metal' appearance with a much thinner label than the conventional aluminium foil. There is now a huge choice available to the brewer and this whole area of packaging is subject to continuous development as brewers strive for brand differentiation and product enhancement. Cut labels, ready for use are supplied in storable stacks, which must be kept at a relative humidity of 60 to 70% and a temperature of 20 °C (68 °F). This prevents curling which otherwise renders the labels useless for application.

A number of different adhesives have been successfully used to attach labels to beer bottles (Schwartz, 1997). The most common and successful are those based on casein. These adhesives apply to cold or wet bottles and will bond rapidly. They provide good resistance to condensate water and to ice water if bottles are submerged. Easy label removal in the bottle washer at low caustic strength is achieved. Alternatives have been based on starch or dextrin. These are cheaper but do not offer such good properties of, e.g., water resistance. To minimize costs as little adhesive as possible should be used and a rate of 10 g of adhesive/m² should be aimed for.

- The labelling machine. Labels are now applied by rotating machines, which can operate at the speed of fillers. The machine contains a label holder and a label-transporting device. Modern machines have improved the reproducibility of the

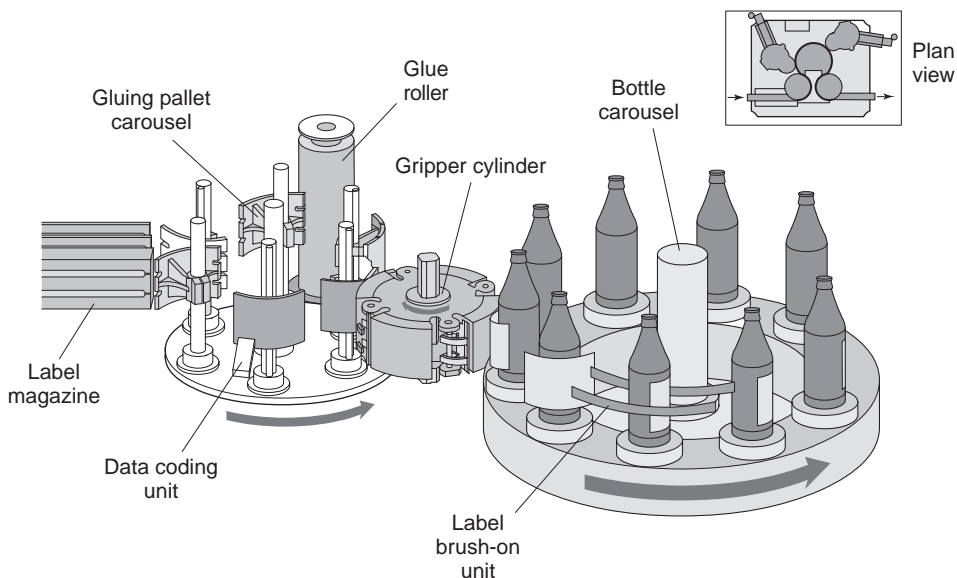

Fig. 21.3 Bottle-labelling station (by courtesy of Kronen).

removal of the label from the stack in the holder and its application to the bottle. Labels not squarely applied to the bottle are not tolerated. A glued pallet with a thin film of glue applied removes the label from the stack in the holder. This results in simultaneous gluing of the back of the label. The machines now usually employ oscillating glued pallets with a smooth motion capable of achieving speeds of 70,000 bottles per hour. The overall design relating to the speed of movement of the bottles and the label length is critical. The speed and distance between the bottles must be carefully set when commissioning labelling machines. Careful design and commissioning will allow the use of a label length that is greater than the bottle pitch (distance between the bottles) with no loss of efficiency.

The labels are normally removed from the pallets and applied to the bottles by gripper cylinders (Fig. 21.3). Body labels and neck labels can be transferred in this way. The body label application occurs when the bottle is smoothly pushed into the sponge section of the gripper cylinder. If a neck label is to be applied the sponge pads in the cylinder must be moved out by cams to make contact with the bottle. The conveying of the bottle through the labeller is critical to ensure that the labels are correctly aligned. Rotary labellers operate with an infeed star wheel that passes the bottles to a centring bell which firmly positions the bottle against a plate to receive the label. To eliminate skewing the bottles are positively clamped between the bottle plates and the centring bells. After application of the body and neck labels the bottles are rotated through 90° and pass a brushing station, which ensures firm contact between the label and the bottle. If a back label is to be applied, the bottle is turned a further 90° to meet the back label gripper cylinder and the application process is repeated. After all labels have been applied the bottles are discharged from the labeller via a star wheel to the discharge conveyor.

Usually a date stamp is now put on the bottle. This might indicate the 'best-by' date or the date of packaging of the beer known as the 'born-on' date by one manufacturer. These dates are sometimes required by law or by the customer but in any event give

the drinker a view of the shelf-life of the beer. The date can be put on the label but is often applied to the bottle itself. The brewer is also likely to include a reference mark, which will be important for product traceability. These reference marks were traditionally cut into the edge of the label and this can be done at manufacture of the label. Recently other methods have been developed, which include stamping and embossing or perforating machines that can operate at up to 60,000 bottles per hour. These devices have largely been superseded by ink-jet or laser printers. The ink-jet system uses a charged stream of ink droplets in a controlled trajectory onto the bottle surface. The laser directs the energy beam through a metal mask that has the appropriate information cut out. The beam is then focused on the label, which suffers a change of colour by evaporation to leave the date stamp clearly marked.

Labelling is an important part of the bottling process, vital for the maintenance of the brand image. Developments in label application have now caught up with that of filling and crowning to guarantee the presentation of a very high-class package. This has been important in re-establishing the bottle against the can as the preferred package for small pack beer.

21.3.2 Managing beer flow

Managing the beer flow involves bringing the beer to the package in the most efficient way, consistent with the highest quality being obtained. Almost all bottled beers are now sterile, filtered products. Sterility is traditionally achieved by pasteurizing the beer in the bottle after filling and crowning. However the beer can be sterilized before filling by flash pasteurization or sterile filtration. This is what happens with keg beer, which cannot be tunnel pasteurized because of the huge size of the machine which would be required. Flash pasteurization is not widely used with bottled beers, although new developments are occurring (Hyde, 2000), and this technique will therefore be considered in the section on kegging. In managing the beer flow we are concerned with:

- flash pasteurization or sterile filtration
- standard filling and aseptic filling
- crowning
- tunnel pasteurization.

Until recently beer was not moved long distances for sale and so microbiological stability of the product was not an issue. Modern microbiological stabilization processes began with the work of Louis Pasteur (Pasteur, 1876), who demonstrated that heating beer to a sufficiently high temperature would destroy beer spoilage microbes. Fortunately beer is not a good growth medium and only supports slow growth of a relatively small number of microbes (Rainbow, 1971), which does not include pathogens (Bunker, 1955; Chapter 17)). The task of providing the customer with a microbiologically stable product is therefore simplified.

Absolute security in the sterility of bottled products is required. Bottles may be distributed over very long distances, and often have shelf-lives of 40 to 52 weeks. The traditional practice has been to pasteurize the beer after filling in its final package (see later). However this process is very energy intensive, requiring at least 1,000 MJ/1,000 bottles. Beer flavour is adversely affected by pasteurization and probably suffers even if oxygen contents are kept to levels < 0.1 mg/l. This has led to the use of filtration to sterilize the beer prior to filling. Sterile filtration physically removes organisms from the beer. The technique demands subsequent aseptic filling and the application of rigorous standards to ensure no contamination enters the bottle.

Sterile filtration

Some of the techniques used to achieve non-biological stability (Chapter 15) of beer have been used and claimed to yield sterile beer. So plate and frame filters using pulps of kieselguhr or perlite or sheet filters using asbestos/cellulose sheets are said to be effective for sterile filtration as well (Wilson, 1997). This type of sterile filtration was originally described in the 1930s by the Seitz Company that developed the EK sheet (*Entkeimung* = sterilization). These sheets were made of a mixture of cellulose and asbestos and were 4.5 mm thick with a pore size of 5–20 μm . Flow rate achievable was 1.5 $\text{hl}/\text{m}^2/\text{h}$ at a maximum pressure of 1.5 bar. The quality and composition of the sheets has changed much in recent years (Chapter 15) and beer stabilizers can now be incorporated into the sheet such as PVPP (polyvinylpyrrolidone) or silica hydrogel.

These pulp and sheet methods act by depth filtration. The pad or sheet contains millions of flow channels. Micro-organisms are mechanically entrapped or absorbed as the beer flows through the filter. There is also an adsorptive effect as microbes are fixed by electric charge. The organisms bear a negative charge, which attracts to the positive charge of the filter matrix. These methods have been used for sterile filtration of beer. However, since the carcinogenic properties of asbestos were recognized, asbestos was replaced in sheet filters with kieselguhr or perlite. Some brewers lost confidence in depth filtration as a method to guarantee beer sterility. The situation was changed with the availability of membrane filters.

Membrane filters can be classified as surface filters which operate on a sieving method for the removal of organisms (Wilson, 1997). The membrane is a uniform continuous structure with regularly spaced uniformly sized pores. The membranes are made of cellulose esters and are normally 150 μm thick (Bush, 1964). As beer passes through the filter all organisms larger than the pore size of the filter are trapped and retained on its surface. For brewery use a pore size of 0.45 μm is necessary to retain all potential spoilage microbes. Membrane filtration is the only sterile filtration method that will provide absolute sterility. However, membranes are prone to blockage and it is essential that the beer presented to the membrane has received satisfactory primary filtration. The beer must be free of particles that will blind the sterilizing filter, the sole aim of which is to achieve sterility. This is now achieved by a sequence of filters after the primary kieselguhr filtration. These are frequently cartridge filters. There can be two or three in line with reducing pore sizes, e.g.,

- kieselguhr filtration
- cartridge filter 1, 5 μm pore size
- cartridge filter 2, 1 μm pore size
- sterilizing membrane filter, 0.45 μm pore size.

Using a system of this type, high throughput and sterility can be achieved. A non-destructive test to indicate the suitability of beer for membrane filtration has been described (Pall, 1975). It is also important to have sound microbiological control throughout the brewery so that the effectiveness of the sterile filter is further enhanced.

Other types of filter have been described (Moll, 1994). Ceramic candles have been used in Japan. Flow rates of 10 $\text{hl}/\text{m}^2/\text{h}$ were achieved with ceramic candles of 25 mm wall thickness and a pore size of 25 μm (Beer, 1989). Cross-flow filtration methods have also been tested, where the liquid flow is tangential to the filter medium (Atkinson, 1988). Tubular membranes and sand have been used as the filter medium. These systems are not fully developed for beer and have been prone to blockage with non-microbiological polymers present in the beer such as β -glucans. If the pore size is

reduced to below $0.45 \mu\text{m}$, which has been the case in some systems, bittering substances are removed from the beer (Donhauser and Jacob, 1988). Absolute sterility has not been consistently achieved on the industrial scale using cross-flow methods.

Sterile filtration has the advantage over pasteurization of giving very gentle treatment to the beer; with no heating and cooling there is no potential for flavour changes. The additional filtration can also improve non-biological stability and clarity of the beer. The technique has lower capital and operating costs than tunnel pasteurization. Sterile filtration must be operated with sterile filling and so this obviously adds to the difficulty of the filling operation. There must be a buffer tank between the sterilizing filter and the filler and a constant flow must be obtained to avoid pressure shocks. The pressure drop across the filter should be monitored. A drop in pressure of 2 bar (30 lb./in.^2) is acceptable. Care must be exercised when changing tanks to be filtered or when filtering tanks at low beer levels. Gas bubbles can break out at the filter pump which can give a sudden pressure drop and hence a loss of sterility in the system. This can be avoided with proper attention to the monitoring of pressures and flows.

Sterile filtration must be operated in a sanitary system. Effective CIP is essential. The system must be cleaned, sanitized, and back flushed using hot and cold de-aerated water. Normally water at 80°C (175°F) is circulated for 60 minutes. The CIP system is an integral part of the whole sterile filter plant.

One source of competitive advantage to the brewer is the delivery of the freshest tasting beer possible. This is most likely to be achieved using sterile filtration and filling. Consequently there is great interest in perfecting these techniques.

Standard filling

The filler is the most important piece of equipment in the bottling line. For optimum efficiency the filler must run continuously throughout the shift. Machines before and after the filler must be designed to supply bottles and take them away at least as fast as they are filled and sealed. The beer supply system must keep carbon dioxide in solution and exclude oxygen. The whole filling operation must not add more than 0.03 mg/l dissolved oxygen to the beer. To maintain the carbon dioxide content achieved in the bright beer tank the pressure must be maintained during filling at one bar above the CO_2 saturation pressure. Contamination of the beer must be avoided. Microbiological sterility will be achieved by tunnel pasteurization or by aseptic filling if the beer has been sterile filtered or flash pasteurized.

The objectives in filling bottles are to preserve the quality of the beer and get the right volume of liquid into the bottle. As beer contains carbon dioxide, beer fillers always operate at a high pressure and are generally called counter-pressure fillers. To deliver the required volume of beer, beer fillers are designed either to fill to a level in the bottle or to fill by displacement. Bottle fillers are rotary machines and can rotate clockwise or anti-clockwise. Machines can now contain up to 200 filling valves and can fill at 1,000 to 1,600 bottles per minute. Most fillers perform in a similar basic way (Fig. 21.4, plan view and Fig. 21.6, sequence of operation):

- beer is received
- bottles are positioned in predetermined spacing under the filler heads on the filler platform
- bottles are lifted up to the filler head
- bottles are evacuated and counter-pressured with carbon dioxide
- bottles are filled

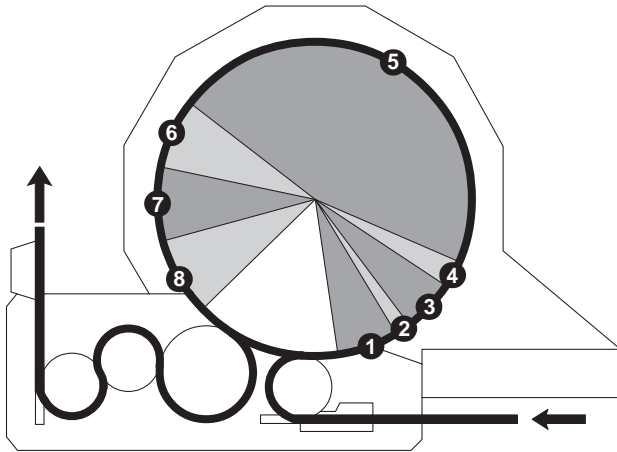

Fig. 21.4 Bottle filling, plan view: 1, 1st evacuation; 2, carbon dioxide flushing; 3, 2nd evacuation; 4, pressurizing; 5, filling; 6, filling completed and settling; 7, correction; 8, snifting (by courtesy of Kronen).

- corrections are made to fill height
- pressure is released
- bottles are lowered and moved onto the crowner, where they are sealed.

Therefore in sequence we have:

- Beer supply. Beers are almost always cold filled into bottles at 0 to 5 °C (32–40 °F). To maintain the carbon dioxide in solution the beer should be at one bar pressure (15 lb./in.²) in the supply to the filler bowl. This is normally achieved by maintaining a carbon dioxide top pressure in the headspace of the bright beer tank. There must be no drop in pressure at the tank outlet and so the beer flow rate should not exceed 225 cm/s up to this point. The beer should not have to traverse right-angle bends (Spargo, 1997). The volume of beer supplied to the filler can be measured in line with a magnetic flow meter provided there is enough straight pipe-work in the flow line for the beer to achieve laminar flow. All fillers have a ‘bowl’ or tank to receive beer from the bright beer tank and to distribute the beer to the filler heads. On large machines (> 500 bottles/min.) the bowl is annular and the beer in the bowl is counter-pressured from above with carbon dioxide. A sensor, which is usually a float valve, controls the height of the beer in the bowl. Filling valves are usually mounted at the bottom of the bowl or attached to the outside of the bowl. In this way beer distribution pipe-work to the filling valve can be eliminated.
- Bottle positioning and lifting (Fig. 21.5). The lifting platforms place the bottles against the filling heads to provide a secure connection. This is done by compressed air. The same device using a roller lowers bottles. Compressed air can be forced back in the lowering process into the supply pipe and so is not lost. The device to position the bottle is called a centring bell or tulip. This is carried up by the bottle being raised. The centring tulip ensures that the bottle is centred in the filling head and sealed.
- Bottle evacuation, counter-pressure and filling (Fig. 21.6). There are a number of different beer filling heads. Beer can be introduced into the bottle via a filling tube. The filling tube reaches to the bottom of the bottle. Obviously the tube must have a smaller diameter than the bottle opening and this limits filling speed. Filling tubes

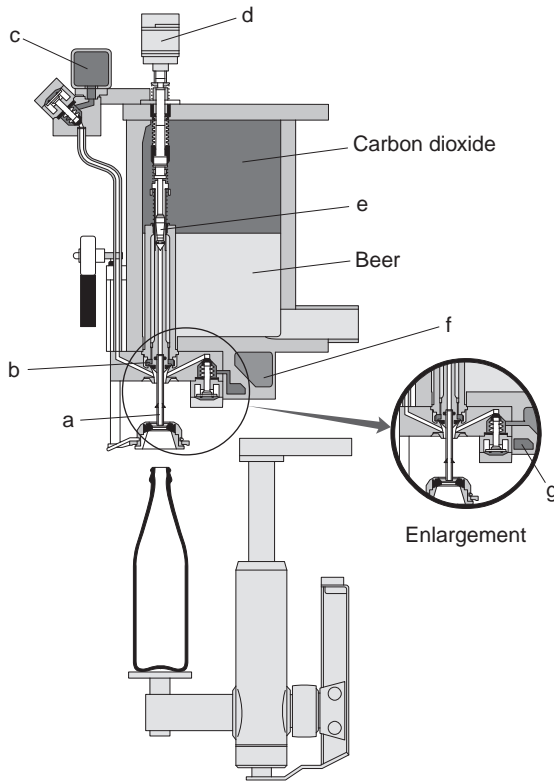

Fig. 21.5 Bottle filling, section view; basic position before the bottle is lifted onto the filling head (air in bottle); a, vent tube; b, siphon type gas lock; c, correction channel; d, control cylinder for liquid valve and pressurizing; e, gas needle; f, vacuum/CIP channel; g, sniff channel (by courtesy of Kronen).

introduce beer just above the bottom of the bottle. There is very little uptake of oxygen. The filling tube is made up of a tube through which the beer passes and a return gas vent at the level of the required filling height. Some high-speed fillers ($> 1,000$ bottles/min.) operate without filling tubes. The beer is introduced down the side of the bottle neck. There is a danger of ingress of oxygen with this system but the system will operate at higher speed than the filling tube system. A sequence of operation for a non-filling tube machine is shown (Fig. 21.6). After lifting the bottle is evacuated (21.6a) and about 90% vacuum is achieved. The next phase is a flushing with carbon dioxide (21.6b), which enters the bottle from the filling bowl. There is then normally a second evacuation (21.6c). The vacuum allows the displacement of the carbon dioxide and some air, which will still be present. The secondary evacuation stage would not be carried out with a filling tube bottle filler. Counter-pressurization with carbon dioxide then takes place (21.6d). The process is similar to the carbon dioxide flush (21.6b) but takes longer and a high concentration of the gas is achieved in the bottle. The pressure in the bottle is now the same as that in the filler bowl. Beer can now flow downwards against the bottle sides in a thin film displacing the carbon dioxide (21.6e). As soon as the beer reaches the end of the vent tube it rises in this tube (21.6f) and the gas above cannot escape. There is an overflow in this stage which must be corrected (21.6g). The beer valve is closed and the gas valve remains open, carbon

1st evacuation

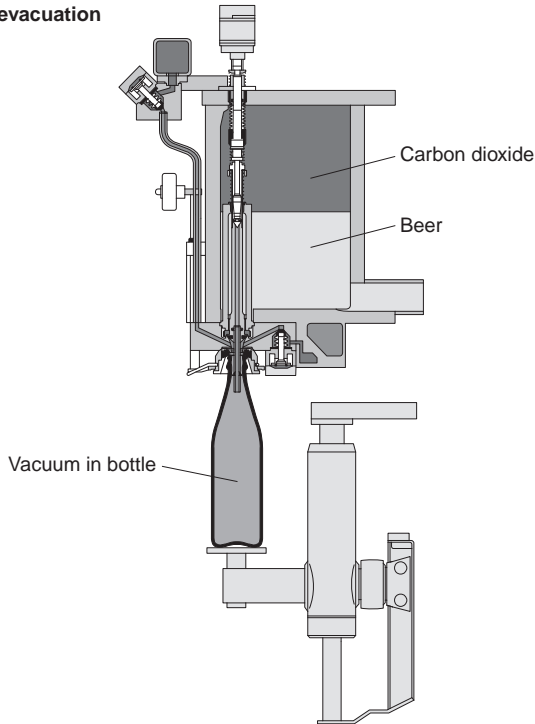

Fig. 21.6 (a) 1st evacuation of bottle (vacuum in bottle) (by courtesy of Kronen).

CO₂ flushing

Fig. 21.6 (b) Carbon dioxide flushing (carbon dioxide in bottle) (by courtesy of Kronen).

2nd evacuation

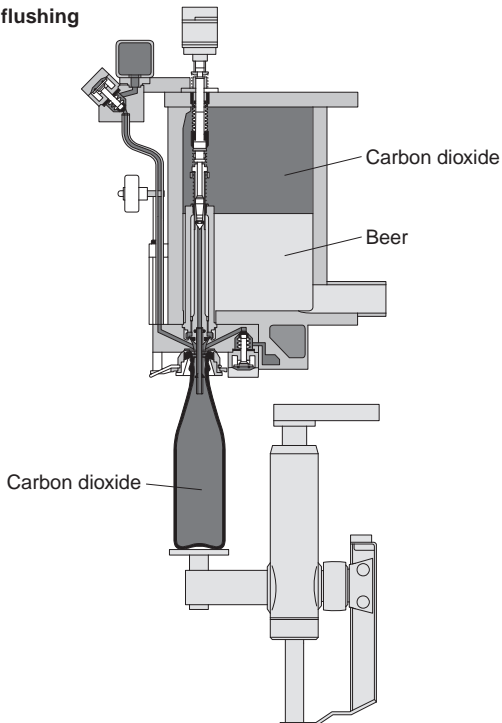
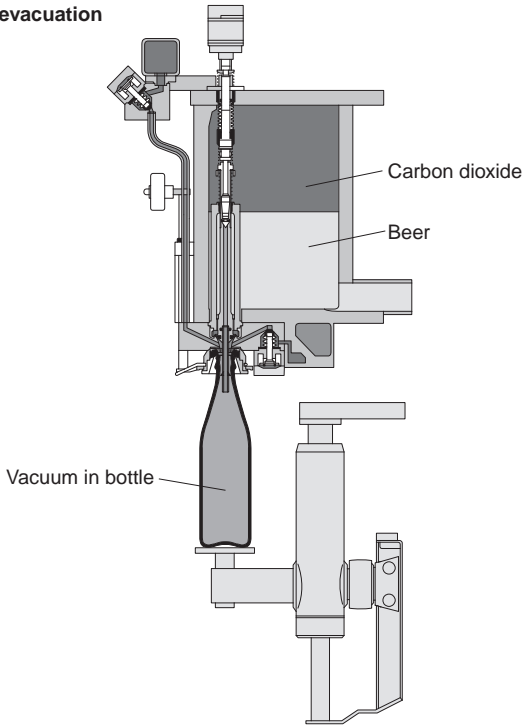

Fig. 21.6 (c) 2nd evacuation (vacuum in bottle) (by courtesy of Kronen).

Pressurization

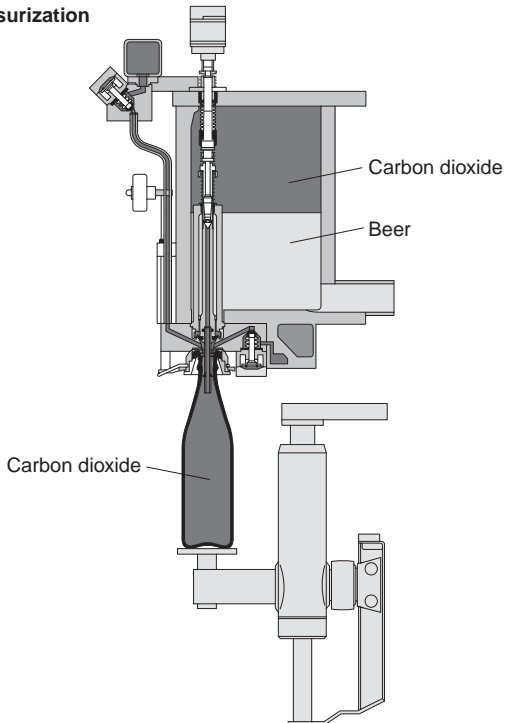

Fig. 21.6 (d) Pressurization (carbon dioxide in bottle) (by courtesy of Kronen).

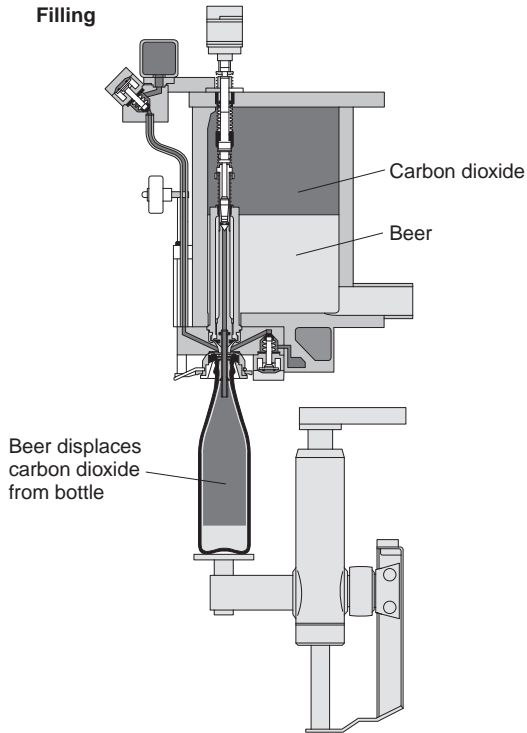

Fig. 21.6 (e) Filling (beer displaces carbon dioxide from bottle) (by courtesy of Kronen).

Filling completed

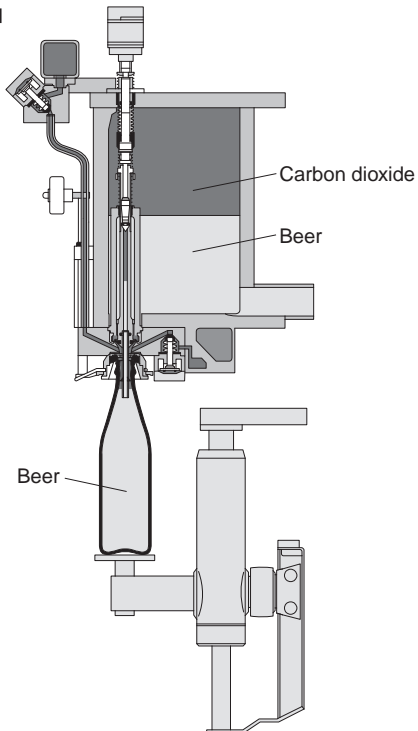

Fig. 21.6 (f) Filling completed (beer in bottle) (by courtesy of Kronen).

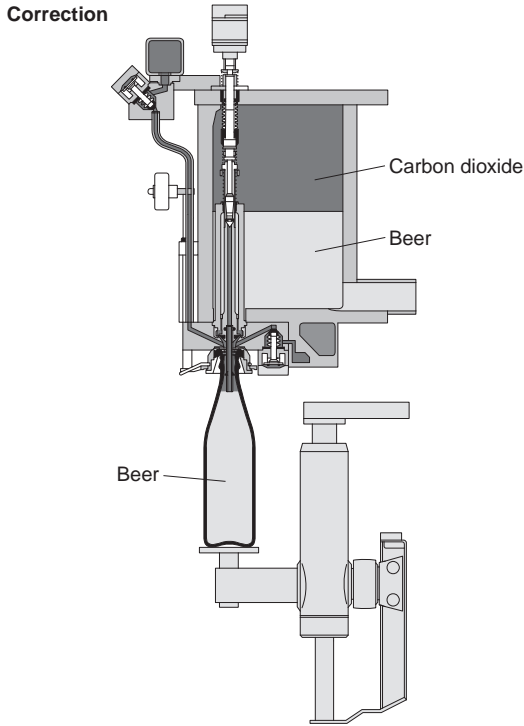

Fig. 21.6 (g) Correction of bottle contents (excess beer displaced back to filling bowl) (by courtesy of Kronen).

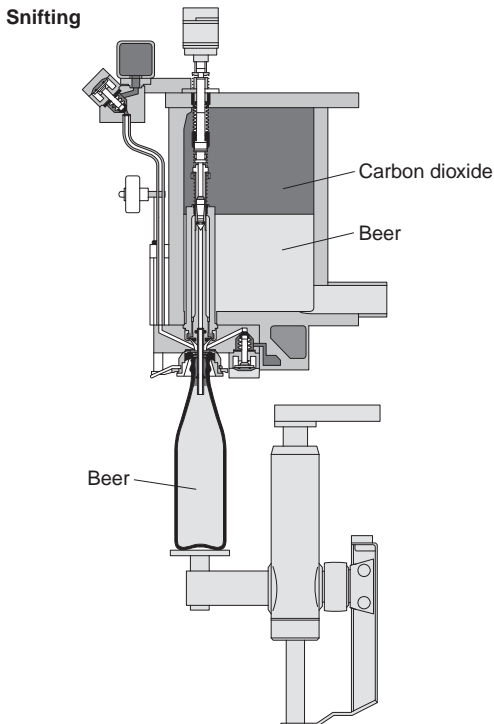

Fig. 21.6 (h) Snifting (controlled pressure release) (by courtesy of Kronen).

dioxide at a small overpressure enters the neck of the bottle and the beer above the vent pipe is forced back into the filler bowl. An exact filling height can so be obtained. There is finally a controlled pressure release known in the UK as a 'snift' (21.6h). This takes place before breaking the seal with the valve and the centring tulip. A vent valve is opened and excess pressure is released so atmospheric pressure is achieved and foaming of the contents is avoided. The gas movements in stage h were formerly controlled using cams, which were very precisely cut; cams have now been replaced by electronic systems. After filling the bottle is lowered from the filling head and conveyed to the crowner.

It is essential *en route* to the crowner to eliminate air from the head space of the bottle to avoid subsequent oxidation of the beer. This is now usually done by water-jetting. A high-pressure stream of sterilized water is sprayed onto each open bottle. Only a few μl of water enter the bottle but this causes an effective beer foaming, which rises in the neck and dispels oxygen and prevents any further entry. This process is carefully adjusted to minimize beer loss. Liquid nitrogen jetting may also be used (Donovan *et al.*, 1999). This technique reduces beer losses and, perhaps more importantly, reduces waste. The foam is formed initially around the nitrogen gas and it is not necessary to expel foam containing air and losses are lowered.

Aseptic filling

Sterile filtration is a powerful technique, which can provide beer in its freshest form. However the technique must be combined with aseptic filling. Aseptic filling requires considerable expertise to achieve success. A number of fundamental requirements must be met. All employees involved in sterile filling must be well trained and be determined to make it work. The beer to be packaged must be free of organisms and therefore must be presented from a well managed sterile filtration plant or from flash pasteurization. If sterile filtered this has probably involved a final pass through a 0.45μ membrane filter. The line must be mechanically reliable. Generally the most satisfactory operation is achieved from long runs. If there are frequent breakdowns then re-sanitization is required with consequent risk to the product and poor efficiency. There must be clearly defined and written-down sanitation procedures. These must include the philosophy on the method of sanitation be it hot water, steam, or chemical.

There must be an effective microbiological control system in place (see also Chapter 17). This is best achieved by the operators on the line being properly trained in microbiological sampling and analysis. In this way the operator comes to 'own' the problem of the line and problems are more likely to be solved. The main focus of the sampling plan is normally the packaged beer. Two samples of beer should be taken off each filler head for every two hours of filling. These can be analysed for contamination by forcing and membrane filtration. Attention should also be paid to the plant, the CIP system and the water in use.

These basic principles and operating philosophy of the equipment are more important in achieving success with sterile filling than the detailed design of the plant. The design must be kept simple and open. The main objective in pipework is to avoid sharp bends likely to restrict the flow of cleaning materials. Pipework and tanks should be made of stainless steel and should be capable of withstanding a flow of hot water at 80°C (175°F) for 30 minutes. Steam can be used for re-circulatory cleansing but generally is not as effective as hot water as it lacks an attrition effect. The filler must be sanitized within one hour of bottling start-up. The best systems have a dedicated CIP system. The water

should flow in the reverse direction to the beer. A final chilled water rinse is usually used and to this water can be added a 25 ppm iodophor solution. This can be left in the system and drained immediately prior to the start of a filling run.

There has been discussion of the desirability of enclosing sterile filling plant in a sterile room. Some systems work successfully in the open in a packaging hall. However, there are advantages in enclosure. One is to show operators and visitors, including customers, that something special is taking place. A carefully designed enclosure allows the control of a sterile air supply in both temperature and humidity. It also facilitates the external cleaning of the plant. Sterile filling runs are usually successful over periods of 12 to 36 h. During this time a continuous sanitation programme is necessary. General housekeeping must include the continuous removal of broken bottles and the spraying of the floor to wash away spilt beer. Foam cleaning the plant with iodophor solution during operation is beneficial to hygiene. Close attention should be given to the filler tubes and the crowner platforms (see later). If production stops during a bottling run then iodophor treatment should continue. If the stoppage exceeds one hour then the plant should be shut down and a full sanitation carried out. The filler must be cleaned at the end of the run by a hot water flush prior to full sanitation one hour before the next run.

The capital cost of a sterile filtration/sterile filling plant can be 10% higher than the costs for a tunnel pasteurizer. However, operating costs are much lower and when assessing all the costs, sterile filling is about half the cost of tunnel pasteurization (Hyde, 2000). Sterile filtration avoids the potential flavour deterioration effects of pasteurization and gives the consumer the freshest tasting beer. This can create potential competitive advantage. However, training and education of operators and acute attention to detail is essential for success. In addition the throughput of the line is not likely to be as good as with normal filling because of the need to sanitize after stoppages.

Crowning

The bottles must be quickly closed after filling. The closure machine is therefore an integral part of the filling machine and comes in the line immediately after the point when air has been dispelled from the bottle neck by water-jetting. Most beer bottles are closed with crown corks. The crown cork evolved from the natural cork stopper. Cork stoppers were effective closures but did not meet the need to be applied at speed. The automatic production of glass bottles was perfected in the USA in 1903 (Everett, 1997). This provided bottles with uniform dimensions at the neck that could take a standard closure. William Painter had already filed US Patent 468226 in 1892 for the 'crown closure'. Painter's crown was lined with cork and characteristically had corrugations in the 'skirt'. Subsequently a crown with no corrugations was designed along with a machine which applied the closure to the bottle and formed the familiar corrugations.

The cork was mostly obtained from oak trees in the western Mediterranean and during the Second World War supplies ceased and prices rose. At this time plastic alternatives to the cork lining were developed. The first PVC (polyvinylchloride) lining was introduced in 1955. Nowadays, the crown cork is made of tinned or chromed steel or stainless steel plate 0.235 mm thick. The brewery logo is usually displayed on the outer surface. The standard crown cork has 21 corrugations and an outer diameter of 32.1 mm, an internal diameter of 26.75 mm and a height of 6.0 mm. The normal lining is plasticized PVC. A lubricant is included in the lining for 'twist-off' crowns so they can be removed by hand. The lining does not affect flavour and is approved for use in most countries. The crown must retain the pressure in the bottle until opened and there must be no gaseous exchange with the atmosphere.

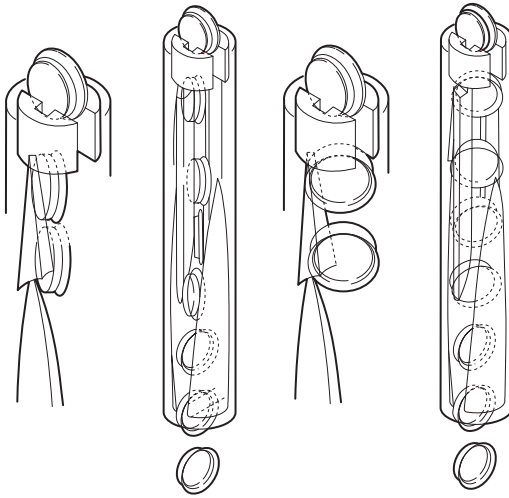

Fig. 21.7 Turning tube for orientating crown corks for bottle closure, incorrectly positioned corks are turned up to 180° to gain the correct orientation for bottle closure (Kunze, 1999).

Crown corks from stock are conveyed to a storage hopper on the closure machine and a sorting device brings them into the correct orientation for closure onto the bottle. Incorrectly orientated crowns are re-positioned in a turning tube (Fig. 21.7) containing fixed inserts before falling downwards through a groove. This device is simple and effective but is subject to heavy wear and so it must be replaced regularly to avoid frequent stoppages as crowns become jammed in the tube. Crowns are delivered to the closure device either mechanically or pneumatically, preferably using carbon dioxide or, less desirably, air. A magnet in the ejector then holds the crown cork. The bottles are delivered to the crowner by a star-wheel and the crowner head, containing the correctly orientated crown, descends onto the bottle. The crown then makes contact with the crown ring of the bottle. A spring forces closure onto the bottle and the 21 corrugations of the crown cork are bent down onto the bottle neck. A gas tight seal is obtained. The bottles are usually sprayed with water to blow off any beer residues arising from the removal of head-space air.

Inevitably, some returnable bottles are damaged and this damage is sometimes to the neck of the bottle. This can affect the security of the crown cork closure. In one case this resulted in as many as 800 defective closures per 1 million bottles by one Company (Duffy and du Toit, 2000). Development work on the crowning machine followed by improved preventative maintenance led to a reduction in defective closures to five to eight per million and a consequent enhancement of the presentation of the brand whilst retaining the environmental friendliness of the returnable bottle.

Sometimes other bottle closures are used. A 'rip-off' closure has been developed, made from light gauge aluminium that can be applied in modified crown cork closure machines. This type of cap has also been used on wide-mouth bottles that are easier to drink from. Roll-on closures have also been used on 32 oz. bottles in the USA. These are normally pilfer proof where the cap is held to a ring by uncut metal 'bridges' which fracture when the cap is turned by hand to open the bottle. The ring remains on the bottle. Largely because of waste disposal reasons these closures have not been popular in Europe except on two-litre PET (see later) bottles.

Tunnel pasteurization

The surest way to provide the customer with beer containing no viable micro-organisms is to treat it at the last possible moment. That is, the beer is treated in its package after closure. The beer is not exposed to the atmosphere until it is consumed. This is achieved by pasteurization (Pasteur, 1876). Pasteurization is the killing of micro-organisms in aqueous solutions by heat. Beer can be pasteurized in bulk while flowing, which is known as flash pasteurization, or in the package, which is known as tunnel pasteurization. Flash pasteurization occurs before the beer is put into its final container and so is an alternative to sterile filtration. Flash pasteurization is usually associated with the preparation of keg beer. Tunnel pasteurization is most commonly used with small-pack beer, either bottles or cans. The theory of pasteurization is common to both systems.

- Theory of pasteurization. The basis of pasteurization is establishing the minimum time and temperature required to destroy all expected biological contaminants at the highest concentrations at which they may occur in filtered beer. Different food products have different requirements for pasteurization, and those that can contain spore-forming bacteria require much higher heat treatment than beer. Mixed populations of common brewery contaminating organisms were subject to a range of times and temperatures in beer (Fig. 21.8, known as a lethal rate curve) and were examined for subsequent viability. Typically at temperatures of over 50°C (122°F) an increase in temperature of 7°C (12.5°F) accelerated the rate of cell kill by ten times. Therefore:
 - 53°C: minimum time to kill population 56 min.
 - 60°C: minimum time to kill population 5.6 min.
 - 67°C: minimum time to kill population 0.56 min.

One pasteurization unit (PU) for beer has been arbitrarily defined as the biological destruction obtained by holding a beer for one minute at 60°C (140°F) (Del Vecchio *et al.*, 1951). Therefore in Fig. 21.8 the point at which the line crosses the 60°C line

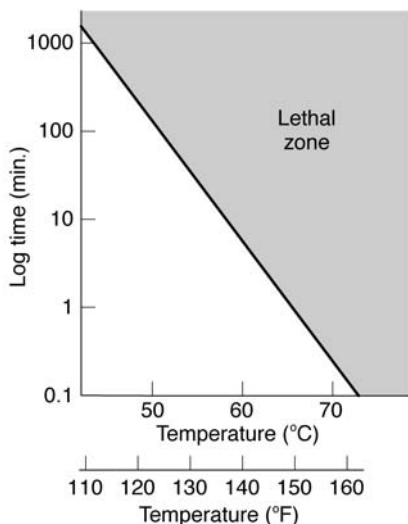

Fig. 21.8 The effect of time and temperature on the viability of a mixed population of yeasts and brewery bacteria. The hatched area shows the range of conditions where all cells are killed (Hough *et al.*, 1982).

gives the thermal resistance of the particular suspension of organisms, this is 5.6 min and so to achieve effective pasteurization the holding time at 60 °C (140 °F) must exceed 5.6 min. The slope of the line in Fig. 21.8 is known as the Z value. The lethal effect (PU) is simply the product of the lethal rate and the time of application. The lethal effect at various temperatures in a process is additive, therefore the sum of the lethal effect is the quantity of sterilization achieved:

$$\text{Lethal Effect} = \text{Lxt(PU)}$$

where L = Lethal Rate and t = time held at temperature T °C and

$$L = 1/\text{Log}^{-1}(60 - T/Z)$$

Under laboratory conditions beer can be sterilized by treatment with 5–6 PUs when cell numbers are < 100/ml. However, most brewers would regard this low level as unsafe in practice and would choose treatment at 15–30 PU (Willox, 1966). The level chosen should be as low as possible, consistent with achieving sterility. Flavour deteriorates following pasteurization particularly when the dissolved oxygen content is > 0.2 mg/l. The most heat resistant organisms are the lactic acid bacteria and some *Saccharomyces* species such as *S. pastorianus*. The pasteurization of returned beer is more difficult because this can contain very high numbers of organisms. It is usually only blended into fresh beer at low rates (< 10%) after filtration and so any potential flavour effects of excessive pasteurization (> 50 PU) are minimized.

- Practice of tunnel pasteurization. A tunnel pasteurizer comprises a large metal-cased enclosure through which the bottles are passed by a conveying system (Fig. 21.9). The conveying system can use a slat continuous conveyor chain on which the bottles are slowly moved or can use a walking beam conveyor. In a walking beam the bottles stand on bars and are slowly moved forward in cyclical steps (Fig. 21.10). The walking beam has the advantage that the moving elements remain in the same temperature zone whereas the continuous conveyor inevitably carries some heat and water away to another zone. The pasteurizer operates as a series of zones. The bottles are loaded at one end and then conveyed under a series of water sprays. The sprays are arranged such that the bottles are subject to increasingly hot water until the beer in the bottles reaches the pasteurization temperature. In tunnel pasteurizers this temperature is usually 60 °C (140 °F), which is held for 20 min. This delivers 20 PU to the beer. The bottles then move to a cooling zone where they are subjected to cooling by cold water sprays. The bottles then leave the pasteurizer.

Most modern tunnel pasteurizers are double-deck machines (Fig. 21.9). The bottles travel to the end of the top deck of the pasteurizer and then go down to the lower deck. In this system the water in the sprays on the top deck pre-heats the bottles and passes to the lower deck to be used for cooling. Exact control of temperature is important. The objective is the effective kill of all organisms with the minimum use of energy. Temperatures in all the zones are recorded and often computed with the time to show pasteurization units supplied. Passage through the machine normally takes one hour. Tunnel pasteurizers are the biggest piece of equipment in the packaging line and a surface area of 3.5 m²/1000 bottles/h is needed to ensure effective pasteurization. Modern machines can achieve outputs of at least 150,000 bottles/h. The water used in the pasteurizer must be clean and kept at a pH value of around 8. If not the pasteurizer will become grossly infected with a variety of bacteria and moulds and the sprays will

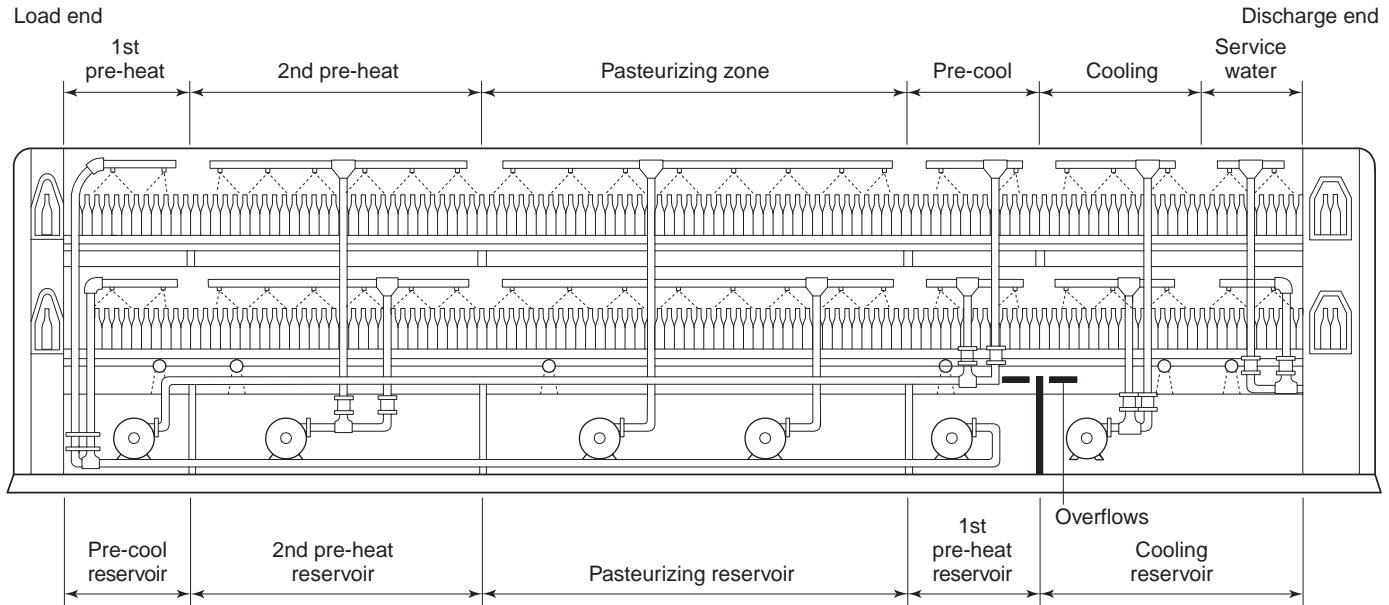

Fig. 21.9 General arrangement of a double-deck tunnel pasteurizer. Times and temperatures for the various zones: 1st pre-heat, 5 min. at 35–50 °C; 2nd pre-heat, 13 min. at 50–62 °C; Pasteurization, 20 min. at 60 °C; Pre-cool, 5 min. at 60–49 °C; Cool, at 49–30 °C; Discharge, 2 min. at 30–20 °C. For can pasteurization the pre-heat and cooling zones may be shortened in length and therefore the beer spends less time in these zones, because of the lower structural strength of the can (Hough *et al.*, 1982).

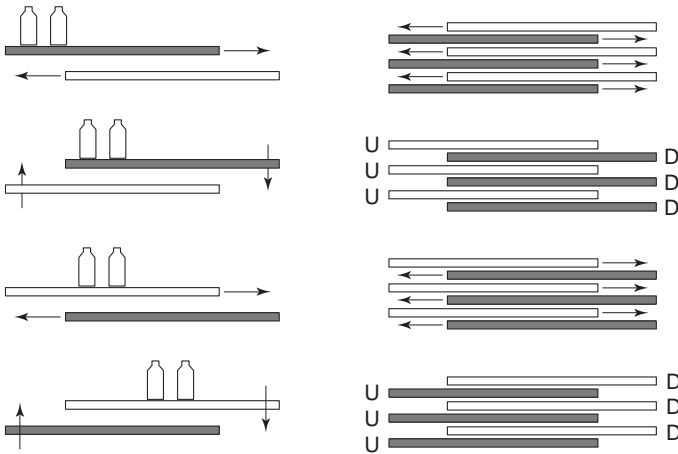

Fig. 21.10 Walking beam principle for moving bottles through a tunnel pasteurizer. Left-hand sequence represents side elevations showing successive movements of shaded grid beams in relation to unshaded grid. Right-hand sequence represents corresponding plan views (D indicates downward movement and U upward movement), (Coleman, 1976 and Hough *et al.*, 1982).

be blocked and the bottles will emerge dirty. Water hardness must be removed or at the very least calcium ions must be sequestered to keep them in solution so that the bottles do not dry with a coating of calcium salts. Sometimes bacteriocides containing chlorine are added to the water.

During pasteurization pressure builds up in the headspaces of the bottles. The exact pressure build-up depends on the volume of the headspace, which must be accurately controlled by fill height to limit possible bottle breakage. Carbon dioxide can also be released from its supersaturated state in the bottle if the bottles are knocked during pasteurization. If the bottle is defective the bottle may burst or carbon dioxide may leak allowing a reduction in the gas content of the beer. For example, if the carbon dioxide content of the beer is 0.38% and the percentage headspace in the bottle is 1.7%, the pressure would exceed 10 bar during pasteurization if supersaturation did not hold. A walking beam conveyor is generally better at avoiding bottle knocks than a slat conveyor. If effective controls of fill height are in place bottle breakage should not exceed 0.2% of the total bottles processed.

Tunnel pasteurization is a very safe method of assuring sterile beer. It is, however, the most expensive method of assuring sterility in both capital and operating costs (Hyde, 2000), which are double those of sterile filtration and at least five times more than for flash pasteurization (see later). It is also a fault of tunnel pasteurizers that it is easy to overpasteurize the beer. The beer will then not taste fresh and, particularly if the dissolved oxygen level was > 0.2 mg/l, will very quickly develop a cardboard flavour. This has stimulated interest in sterile filtration and flash pasteurization for small pack beer.

21.3.3 Managing plant cleaning

All areas of a packaging plant must be kept clean, using a rigorous housekeeping regime. This is particularly important in a bottling plant, because breakages of bottles will occur and the broken glass is a threat to employees and the product. It must be removed at once.

The floor area around the filler should be disinfected daily. Thorough cleaning of the filler and crowner is essential. Infection can develop in the filler; usually as a result of *Acetobacter* infection, which develops on residues of beer and foam. Slime caps are formed which can provide encouragement to other organisms particularly *Lactobacillus sp.*, which will grow in beer at very low oxygen levels. This may result in a need for increased pasteurization with a consequent adverse effect on beer flavour.

Thorough mechanical cleaning of the filler and the provision of a hot water flush unit avoids infection. After bottles have left the filler this device can provide an overflow of hot water at 90 °C (195 °F) in the filling machine, at the point of delivery of the crowns and over the star wheels. The sequence can be arranged so this overflow occurs every 2–3 hours, during 2–3 filler rotations at half speed. This should be supported with foam cleaning of the conveyors and spraying with iodophor at the end of each bottling run. The key to successful plant hygiene is management and training. Even if tunnel pasteurization is to take place after filling this is not an excuse for poor hygiene management.

21.3.4 Materials for making bottles

The most important material for both returnable and non-returnable beer bottles is glass. Glass exists at room temperature as a super-cooled liquid. It is chemically inert and will not add or take away properties from the product it contains. Glass will only break under tensile load and the compressive strength of glass fibres is such that they will withstand 34,000 bar. Glass is recyclable and cullet, broken glass fragments, is an important constituent of new-made glass (Moll, 1997).

Glass bottles can be made in several different colours but the choice of colour is important for the flavour stability of the beer. White light can act on the iso α -acids in beer to form a compound, 3-methyl-2-butene-1-thiol. This imparts an aroma and flavour known as light-struck or 'skunky', and renders the beer very unpleasant. It can be detected by some people at a concentration of 0.4 parts per trillion (0.4 ng/l)! Beer must therefore be protected from light. Brown glass is the best option and is much better than green glass in this respect. The worst type of glass is clear (flint) glass in which the flavour of beer deteriorates very rapidly when exposed to light. Marketing departments frequently want to use green or flint glass for beer considering that it gives the beer a more attractive appearance. This is resisted by brewers concerned about flavour risks. This is one reason why reduced isohumulones are now added to some beers. These compounds do not break down under light to the thiol. The compounds also have increased hydrophobicity compared to isohumulone and so they also enhance foam (Chapter 19).

Bottles can be made to very exacting specifications, which are often controlled by statute. Bottles can be assessed by a number of quality control methods to ensure satisfactory performance on the line (Moll, 1997). Consumers prefer glass for the packaging of small pack beer believing it gives a more upmarket image and better flavour to the beer (Yeo, 2000). In the UK in 1998 the non-returnable market was split: cans 69%, glass bottles 30%, plastic bottles (PET) 1%. Polyethylene terephthalate (PET) has been the preferred plastic used for containers of soft drinks since c. 1993. This product is gas permeable and carbon dioxide seeps out and oxygen seeps in. This has been overcome for beer by using a gas-proof coating on the PET or by the insertion of a non-permeable barrier between two layers of PET (Nelson, 2000a). These bottles can be recycled and new bottles can be made of 40% recycled material. These new PET containers have greatly reduced oxygen ingress to the bottle and a shelf-life of six months

has been claimed for beer (Nelson, 2000a). Carbon dioxide escape from the bottle remains a problem. The most-used coatings involve a silicon oxide layer on the outside of the bottle, which means the beer is in contact only with the PET.

There is now an alternative to PET, polyethylene naphthalate (PEN). This polymer has 10–15 times greater barrier properties than PET (Nelson, 2000a). This gives the potential to refill the bottles as well as recycle the plastic. Bottles made of PEN can be washed at 85 °C (185 °F) and so can be tunnel pasteurized containing the beer. PEN is much less gas permeable than PET, but is at least four times as expensive. A number of major brewers are now using PET and PEN bottles for beer, claiming the beer is easier to chill in these bottles and that drinking without a glass is also easier. There is no breakage in the supply chain and beer in plastic bottles is more acceptable at sporting events, where broken glass can be dangerous. There are likely to be further innovations in this area.

21.4 Canning

The arrangement of a canning line has much in common with that for non-returnable bottles (see above). This section will concentrate on the differences from bottling, and will focus on the package itself and how it is filled. Beer, in cans, was first test-marketed in the USA in 1935. In 1962 the ‘rip-off’ aluminium can end opening was introduced, again in the USA. Further developments occurred with various side seam techniques using tin-free steel on cans, which were at that time three-piece. The two-piece aluminium can was introduced in 1958, closely followed by other developments. The American domestic market has been dominated by beer in the can. In 1993 the market was split: can, 60%; non-returnable bottle, 25%; returnable bottle, 5%; draught, 10%. Other countries, particularly in Europe, concerned with the problem of empty can disposal, have not encouraged canning and the bottle dominates the market. However, the UK is unique among European countries and again the can is prevalent in the take-home trade. In 1998 the split of the market was: can, 24%; non-returnable bottle, 11%; returnable bottle, 2%; draught, 63%. The canning of beer, therefore, is clearly important in world terms but trends are certainly now towards bottles.

The unique aspects of beer canning relate to the can itself, the unloading and rinsing of the cans prior to filling, the application of the date information and the filling and closing operations. All other aspects of palletizing and de-palletizing, secondary packaging and pasteurization are very similar to the operations associated with bottling.

21.4.1 The beer can

Cans have some advantages to the brewer compared to bottles. They are lighter and unbreakable. They can easily be stacked both in the brewery and in the refrigerator. The can has a large surface area on which to display information about the brand and it can be opened without a tool. Light cannot penetrate the can and so light-struck flavour cannot develop. Disadvantages relate almost entirely to disposal. Domestic disposal is usually to a waste tip mixed with other waste materials. This is not satisfactory. Attempts should be made to compress and recycle cans and to separate the two metals used in can manufacture, aluminium and steel. Making aluminium cans from aluminium ore takes considerable electrical energy. Only 10% of this energy is needed when new cans are made from recycled material. The need for active recycling programmes is clear.

Beer cans are now almost entirely of two-piece construction whether made from aluminium or steel. The can end, reflecting the original American invention, is always made of aluminium. The volume of the can is usually, 33, 44, or 50 cl. The metal used to make the can is largely governed by the conditions prevailing in the industries of the country of origin. Aluminium is almost always used in the USA whilst steel dominates in Germany. Both metals are used in the UK. Beer cans, both aluminium and steel, are characterized as 206 or 202 cans relating to the internal diameter of the mouth of the can. The newer 202 can was introduced to save metal and hence weight:

diameters: 206, 57.4 ± 0.3 mm; 202, 52.4 ± 0.3 mm

weights for 50 cl can (aluminium): 206, 19.32 g; 202, 18.38 g (Kunze, 1999).

The tendency is for most beer canners to use the 202 can.

The two-piece can is manufactured from a coil of plate, which is unwound, lubricated and fed into a blanking press (Scruggs, 1997), which forms the sheet into shallow cups. These cups proceed to an ironing press to form the side wall of the can. More metal is retained at the top and bottom of the can for strength but in the side wall the thickness will be only 0.09 mm. The subsequent strength of the filled can relies on the internal pressure of the beer in the can. Trimming follows ironing to ensure uniform height. During these processes the can is covered with lubricant that is removed with sprays. External decoration on the can is applied by a rotary machine using inks and/or varnishes, which are stabilized by baking. Internal coatings are applied by an airless stationary spray-gun and the cans are then baked again to cure the coating and remove solvent. The final process is the die necking to achieve the 206 or 202 diameter. The cans are supplied to the brewery on pallets. For 33 cl cans 8,280 cans can be put on one pallet in 23 layers. For canning lines operating at 2,000 cans/min. the constant supply of cans to the canning line is critical for success. Manufacturers of cans often have plants close to major brewery sites.

Can ends are made from 0.27 mm thick aluminium sheet. The end contains the ring-pull, which nowadays is almost entirely of the 'stay-on-tab' type which means that separated, and discarded rings do not pollute the environment. Lids are supplied with a diameter of 64.75 mm which, after fitting to the body of the can, is reduced to the appropriate size for the 206 or 202 can.

21.4.2 Preparing cans at the brewery for filling

The main concern with handling cans, compared to bottles, is the delicate nature of the can and that it arrives pre-decorated. This decoration must not be damaged, as it cannot be repaired. Cans are pushed off the pallets in layers onto a flat conveyor chain. There must be no gaps between the cans so they cannot fall over. The spacer packaging and the steel frame of the pallet is normally returned to the supplier. Can lids are also supplied on pallets, which can contain 250,000 lids packed in bags of 600. The 'best-by' date is usually displayed on the base of the can. This is usually applied while the can is dry, i.e., before rinsing and filling. The normal method is to use an ink-jet printer, which can match the speed of can filling. Cans are always rinsed before filling by spraying with water whilst in the inverted position. The motive force for this act is usually gravity and hence cans are unloaded at a height of 3 m and then pass down through the rinser to the filler. Cans are delicate and have little structural strength when empty. They will not, however, break like glass bottles and so concerns about glass fragments demanding complex inspection machinery are not relevant to canning.

21.4.3 Can filling

The most important machine on the canning line is the filler. There are similarities in the machines used for filling bottles and cans. Some machines are dual purpose and have the change parts to fill bottles and cans. Dedicated machines are used for choice because the speeds at which a can filler can run are about twice those of a bottle filler. A 100 head can filler will operate at least at 2,000 cans per minute. The main technical differences between bottle and can filling derive from the properties and size of the empty can. Thus, cans have a very wide neck and so provide a large surface area for gaseous exchange during filling. This can lead to a loss of carbon dioxide and ingress of oxygen and cans are very light and will not resist a vacuum so they are not evacuated during filling. The filling tube has similarities with the short bottle filling tube. A quiet fill down the side of the can is achieved by lowering the filling assembly to achieve an air-tight connection with the can, i.e., the can is not lifted in this process.

The technique of centring the delicate can is important. Some very clever designs allow operation at high speed ($> 1,500$ cans/min.) with no oxygen entry. Between the lowering centring tulip and the fixed filling tube is a differential pressure chamber that connects to the internal space of the can. During counter-pressuring and filling this chamber maintains the filling pressure. There is only a small difference between the diameter of the pressure chamber and the diameter of the can and so there is only a small force on the can during filling. After filling the volume in the differential pressure chamber is reduced and pressure increases and the can is thus released from the seal.

The beer is held in an annular filling bowl under a blanket of carbon dioxide. The filling valve is supported by the annular bowl (Fig. 21.11). The sequence of filling is:

- carbon dioxide purging
- counter-pressuring
- filling
- venting
- lifting the valve.

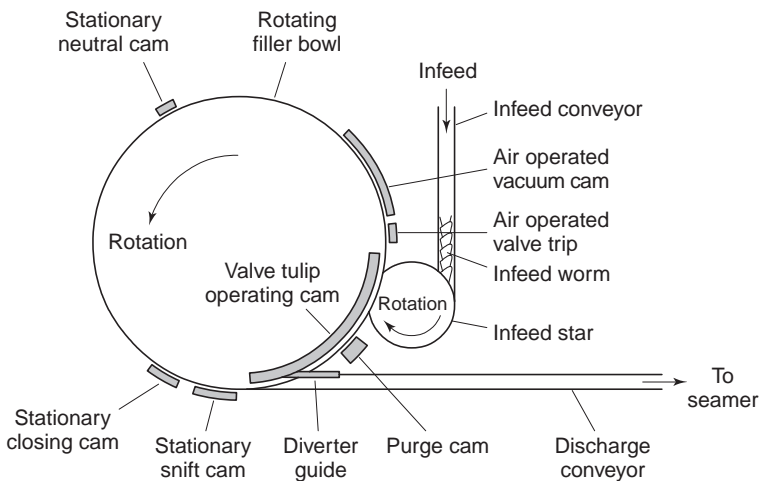

Fig. 21.11 Can filling, schematic. Cans are fed to the infeed star, which places them on to the filler bowl platforms, one can beneath each filling valve. The can filling sequence then operates; as the bowl rotates, cams remove air from the can, charge with gas, fill with beer, close the valve and remove residual gas. (Heins and Heuer, 1997).

During filling the filling valve is lowered along with the filling tube, the return air-pipe and the differential pressure chamber. The airtight connection is so formed. The can is then counter-pressured with carbon dioxide and the beer valve opens introducing the beer quietly down the side of the can from, usually, 15 tubes. In some can fillers these small tubes are replaced by a valve, which delivers the beer in a thin film down the whole of the can side to the bottom. The evacuated air flows up the return air pipe until the beer level reaches the pipe. The pipe contains a ball, which rises with the beer and closes the inlet. This controls the height of liquid in the can as with bottle filling. The position of the return air-pipe can be adjusted. The centring tulip is then raised, the differential pressure is increased, and the can is released from the seal and proceeds to the can seamer for closing. There is little fob in this process and it is not economic to attempt recovery from the evacuated air. In some systems after filling, jetting carbon dioxide over the beer surface breaks any bubbles of carbon dioxide or air.

Controlling filling height by the position of the return air-pipe is an established procedure for bottles and cans. This does, though, require slowing the filling process towards the end. For this reason there has been a desire to develop procedures of volumetric fill where the exact filling volume is pre-determined (Fig. 21.12). A volumetric can filling system has been described (Kunze, 1999) in which the volume is measured in a thin measuring cylinder by a floating ultrasonic sensor. The cylinder is filled from below without turbulence and is hence charged to deliver the appropriate volume at the beginning of the filling process. This allows a speeding and standardizing of the filling process.

21.4.4 Can closing (seaming)

There is a large surface of beer in the can and so the lid must be secured as soon as possible to keep out oxygen and to minimize dissolved oxygen levels (≤ 0.2 mg/l). Cans must be hermetically sealed to be impervious to air, liquids and bacteria. The closed can must withstand the internal pressure and be robust enough to survive distribution and retail display.

The can lid is usually placed on the can whilst the can is on the filler carousel. The can is raised and pressed together with the loosely placed lid against a firm sealing head. A double seaming process follows.

- First operation, interlocking: the outer part of the lid is bent under by a pre-roller with a defined profile.
- Second operation, tightening: an air-tight seal is obtained by pressing with a seaming roller.

Carbon dioxide is blown over the surface of the beer as the can end is being slid into position. Most of the air is blown out and replaced with carbon dioxide (under-cover gassing). Air contents in the head space are < 1.5 ml. A sealing compound incorporated in the curl end of the lid effects the hermetic seal following tightening. The compound may be water-based latex emulsion or synthetic rubber material.

The success of the seaming operation depends on smooth coordinated operation of all moving parts of the seaming machine. Regular, planned maintenance is essential guided by the history of the machine. There should be regular corrective action to ensure the machine is always set precisely for perfect closing of the can. An efficiency of operation of 95% (actual time run versus time planned) should be achievable through proactive planned maintenance. This type of maintenance is best achieved through the team approach with multi-disciplined teams of operators able to work together on the line,

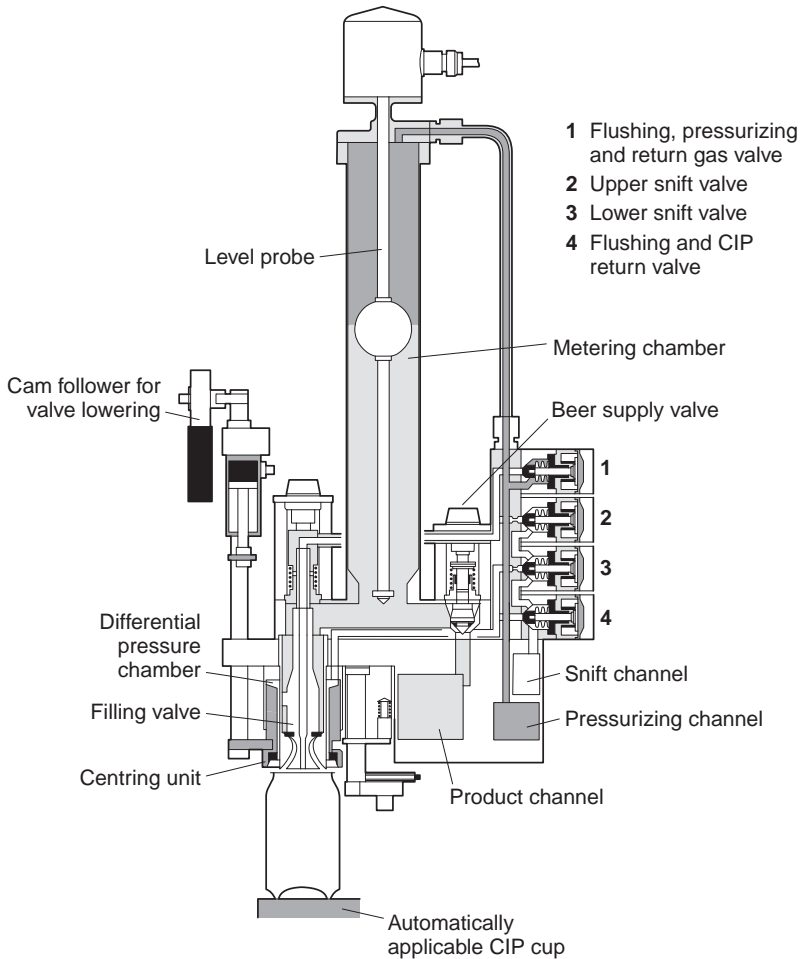

Fig. 21.12 Can filling valve (by courtesy of Kronen).

building up a history of operation and utilizing this knowledge to effect the maintenance plan. Programmes of regular testing for seam integrity should be in place. Standard visual tests have been developed for this as well as destructive tests involving examination of seam tolerances with micrometer gauges (Heuer, 1997).

Since cans are not transparent fill height is usually checked using γ radiation which penetrates the can and checks whether the beer fill height meets specification. Finally almost all canned beer is tunnel pasteurized. Typically beer will receive 20 PU:

- pre-heat 46 °C (115 °F) 1 min.
- superheat 62 °C (144 °F) 3–4 min.
- pasteurize 60 °C (140 °F) 15 min.
- pre-cool 46 °C (115 °F) 2 min.
- cool 32 °C (90 °F) 2 min.

Following pasteurization the cans are dried with jets of compressed air and the fill height is often checked again by γ radiation. Secondary packaging then takes place often to the customer's specification.

Microbiological checks focus on the beer supply prior to filling and the filling and seaming operations.

21.4.5 Widgets in cans

Traditional English ales were, and sometimes still are fermented in open vessels. The natural level of carbon dioxide thus entrained in beer at the end of fermentation was about 1.2 vol/vol or 2.4 g/l (Lindsay *et al.*, 1995). This was therefore the normal carbon dioxide level at which the ale was drunk. Canned ale was frequently packaged with a carbon dioxide content of 2.6 to 3.0 vol/vol. This obviously had a very different taste to traditional cask ale. The beer was much more effervescent and more like a lager beer in mouth-feel. It had been discovered in the 1940s that small amounts of nitrogen gas in beer had a profound effect on head creaminess and durability (Carrol, 1979). This was partly as a result of the low solubility of nitrogen gas in beer (20 mg/l at room temperature and pressure). Nitrogen is colourless, tasteless, odourless and chemically inert. These properties and discoveries suggested the use of nitrogen in the packaging of ale with the objective of providing the drinker with a taste sensation akin to that of cask beer, i.e., low carbon dioxide effervescence and thick creamy head. The problem was to introduce nitrogen into the beer in a reproducible way that could then consistently give the consumer the appropriate taste sensation. Considerable research and development work carried out in the early 1980s led to the development of the 'widget'.

The concept was to introduce a plastic capsule with a small hole and containing nitrogen into the can and to pressurize it during canning. The pressure would be released when the can was opened and the nitrogen would be forced into the beer giving the characteristic creamy head and reflux of bubble formation (Lindsay *et al.*, 1995). Many widgets have been described (Brown, 1997). Some have been more successful than others. Originally widgets were inserted into the can before filling but this did not allow the exclusion of oxygen and hence flavour stability was poor. Now widgets can be supplied already attached to the base of the can. Frequently the floating widget is used since it is less likely to trap oxygen in the can during filling. Liquid nitrogen is often added during filling. Before the development of the widget some companies used solely liquid nitrogen to promote the reflux effect. This technique is still used in the keg packaging of 'smooth flow' ales. In any event oxygen ingress must be kept as low as possible during canning and nitrogen can be used as the undercover gas. Cans often proceed through a tunnel between the filler and the seamer to further prevent oxygen pick-up (Brown, 1997).

Many companies introduced smooth flow ales in cans in the 1980s and 1990s. Some thought that this type of beer would replace standard canned ales with carbon dioxide contents of around 2.5 vol/vol. This has not happened and many consumers returned to the more effervescent product.

21.5 Kegging

Sales of beer in draught form are greater than in small-pack in only the UK and Ireland (Table 21.1). In these countries the sale of beer in kegs is important. Kegging is about filling carbonated, pressurized, pasteurized beer into sterile containers. These containers usually contain 25, 30, 50, or 100 litres of beer. In the UK volumes of 9 imp. gal. (firkin), 18 imp. gal. (kilderkin or kil), or 36 imp. gal. (barrel) are still common. All kegs are

returnable. The collection of empty kegs from depots, bars and public houses is an important part of the overall management of keg packaging (Chapter 22). Kegging has similarities with the packaging of beer in returnable bottles. The major differences concern the handling and cleaning of the much bigger container and the sterilization of the beer. As noted beer in kegs cannot be tunnel pasteurized. The theory of pasteurization (Section 21.3.2) shows how beer can be pasteurized in bulk.

21.5.1 The keg

Kegs are normally made of stainless steel or aluminium. Stainless steel kegs are made of a chrome/nickel alloy. They are heavy; a 50 litre keg will weigh 12–15 kg (around 30 lb.). Aluminium kegs are made of an alloy also containing magnesium and silicon. These kegs are lighter than stainless steel kegs and were originally more popular. However aluminium kegs are more frequently stolen than stainless steel kegs because of the ease with which aluminium can be melted down and sold. Aluminium kegs cannot be cleaned with caustic alkali-based detergents because hydrogen gas is formed. Cleaning is with acid or dilute alkalis. Stainless steel kegs can be cleaned with acid or alkaline detergents and generally are more robust in use, a property that is particularly important as the container ages. Generally, therefore, stainless steel kegs are preferred.

All kegs have a neck containing a threaded bush (Barnes neck) into which fits a keg valve fitting (Fig. 21.13). This fitting is called the spear or extractor tube and through it the filling, emptying, cleaning and automatic closing of the keg is achieved. Kegs have advantages over bottles. They allow the partial dispense of the product and they operate as closed vessels with in-built leakage detection. Keg extractors should not be withdrawn outside the brewery and kegs are returned containing excess gas pressure, which prevents contamination entering. On modern keg filling lines there is a pressure test to demonstrate internal pressure and any kegs not having such a pressure will be rejected and not filled.

Kegs are delivered with the extractor installed and protected from dirt during delivery with a plastic keg cap. To dispense the beer a bayonet-type dispense head is clamped onto the extractor at the bar. This allows the ingress of the top pressure gas and the outlet of the beer to the dispense tap (Chapter 23). There are several types of fitting which means that kegs from different brewers are often not interchangeable on the dispense equipment in the bar.

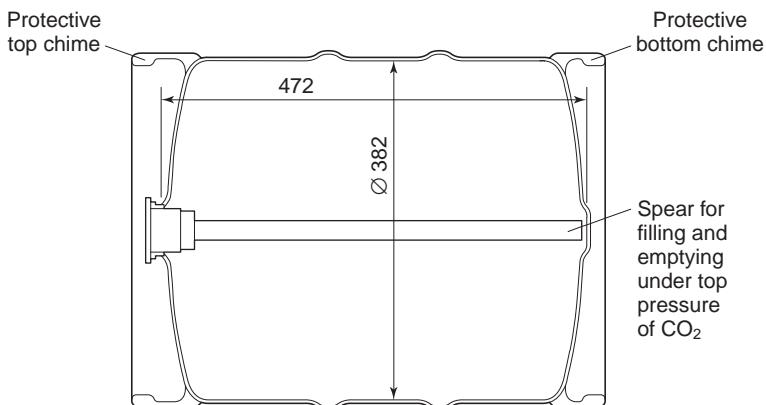

Fig. 21.13 Vertical section of a 50l beer keg, height 472 mm; diameter 382 mm (by courtesy of Alumasc Ltd).

Well-fittings contain two valves, one for the beer, normally a ball valve and one for the top pressure gas. A flat-top fitting has one valve which seals separately the gas and the beer. It is easy to use but is bigger than the well-fitting. The 'combi' fitting is a combination of the well and flat top fitting, but has two valves. Great efforts have been made to make these fittings safe and tamper-proof. It is now an integral part of the filling operation to test for extractor tightness as well as internal pressure in the keg before filling.

21.5.2 Treatment of beer for keggings

Beer for keggings is normally conditioned to yield 1.5 to 2.5 vol/vol carbon dioxide. This applies to ale and lager (Chapter 15). Some 'smooth-flow' ales in the UK are now packaged at carbon dioxide levels of 1.0 volume and with nitrogen contents of 30–40 mg/l. Nearly all beer for keggings is bulk (flash) pasteurized in a continuous flow pasteurizer at high pressure, say 10 bar (150 lb./in.²), against a back pressure of 1 bar (15 lb./in.²).

Flash pasteurization

Flash pasteurization is carried out in a plate heat exchanger in which there are four sections (Fig. 21.14):

- regeneration section
- heating section
- holding tube
- cooling section.

Beer is pumped to the regeneration section where it flows counter-current to hot beer and is therefore pre-heated. In the heating section it is brought up to pasteurization temperature by passing counter-current to hot water or steam. It is then held for a pre-determined period in the holding tube. The beer then passes back to the regeneration section where it loses heat to the incoming beer. It subsequently runs counter-current to cold brine or alcohol in the cooling section. The maximum temperature achieved is between 71 and 79 °C (160–175 °F) and the holding period is usually between 15 and 60 seconds.

It is very important that all the beer flowing through the heat exchanger receives the same pasteurization treatment. Turbulent flow ensures that this is the case. The Reynolds number can be used to ensure that the condition of turbulent flow is achieved. This number is the product of liquid density, velocity and tube diameter divided by liquid viscosity. At Reynolds number values below 2,000 flow is laminar but above 3,000 flow is increasingly turbulent and this should be aimed for.

To change the number of pasteurization units given to beer the temperature is altered. The heat exchanger is designed for a particular flow rate for maximum efficiency. There is a substantial pressure drop through the pasteurizer and to keep carbon dioxide in solution beer is pumped in at 8.5 to 10 bar gauge pressure against a back pressure of 1 bar. The use of buffer tanks before and after the pasteurizer is essential to prevent interruptions of flow and pressure surges on the beer in the bright beer tanks and the keg racker.

Heat transfer in the exchanger is achieved mainly by convection. An important design factor is the surface area required for efficient heat transfer:

$$A = Q/HT$$

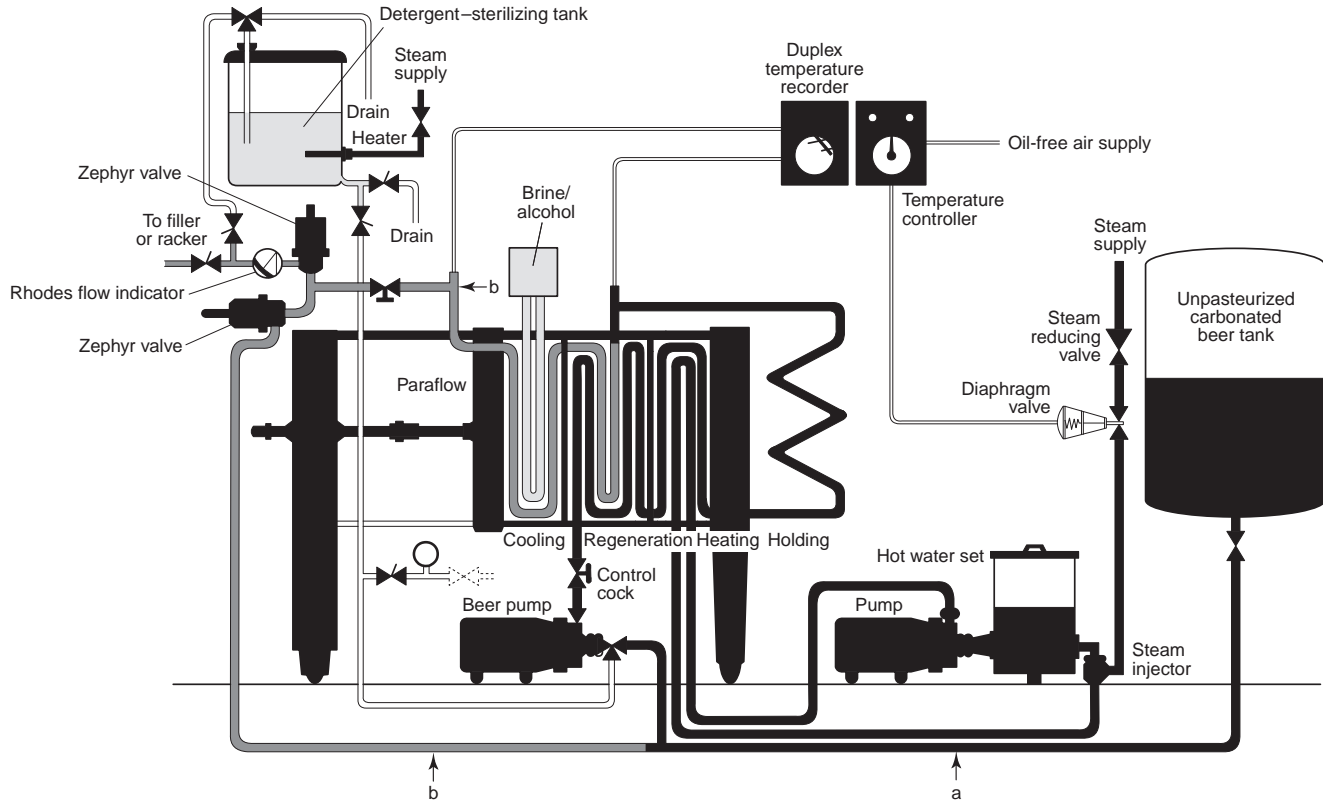

Fig. 21.14 Flash pasteuriser; (a) raw unpasteurized beer, (b) pasteurized beer (by courtesy of APV Co. Ltd).

where Q is the heat load in joules/h, A is the area in m^2 , H is the overall heat transfer coefficient in $watts/m^2/K$, and T is the logarithmic temperature difference (Hough *et al.*, 1982).

Advantages of flash pasteurization compared to tunnel pasteurization are:

- less space required
- lower capital cost of equipment
- lower operating costs (only 15% of the cost of tunnel pasteurization (Hyde, 2000))
- shorter periods of exposure of the beer to temperatures where chemical changes are rapid but pasteurization is slow.

There are dangers for flavour stability of beer with flash pasteurization. If dissolved oxygen levels are >0.3 mg/l more marked flavour changes may occur in flash pasteurization than in tunnel pasteurization. This is owing to higher temperatures and turbulent flow but more importantly, from the recycling of beer back to the buffer tank when the process conditions have not been met or packaging has been interrupted. This leads to excessive pasteurization. It is good practice to circulate water, and not beer, when flow is stopped but this is difficult to control and can lead to beer losses and dilution.

As the beer is sterilized before filling, the kegs that receive the beer must be sterile and filling must be an aseptic operation. Strict microbiological checks downstream of the pasteurizer are essential. A typical pasteurizer may hold the beer for 20 seconds at $75^\circ C$ ($167^\circ F$) and this is equivalent to 50 PU. This high PU value illustrates the need for close control of the pasteurizer to avoid excess pasteurization and consequent flavour deterioration of the beer.

21.5.3 Handling of kegs

Kegs are transported in stacks, which can be arranged horizontally using pallets or vertically using spacer boards. Horizontally configured cradle pallets are very heavy and contribute considerably to the overall weight on a distribution vehicle. Plastic spacer boards are light and allow the vertical stacking of containers up to five stacks high. This system is now preferred in the UK and Ireland.

Empty kegs returning to the brewery first have to be destacked or depalletized. The principle of operation of these machines resembles that of the machines used for handling crates of returned bottles (Section 21.3.1). Destacking is performed layer by layer by pushing the kegs together and lifting by pneumatic grippers. The spacer board can be removed manually or by machine. Stacking the full containers at the end of the line and after labelling is performed by similar machines. The spacer boards can be placed in the stacks manually or by machine.

Efficiency of operation is critical to any kegging line. It depends as much on the supply of the containers as it does on the supply of the beer. It is essential that kegs are 'fit to fill' and that kegs that are not fit do not proceed to the racking machine (*International Bottler and Packer*, 2000). After destacking, empty kegs are tested for internal pressure and tightness of the extractor tube in the Barnes neck. Kegs that fail are removed from the line for subsequent inspection and repair. These kegs may have been tampered with and thus be heavily infected or unsafe. Plastic protective caps will have been removed at the dispense site. The next requirement is to wash the exterior of the keg. Most returned kegs display a self-adhesive label, which will show the details of the previous filling, i.e., the beer quality and 'best before' data. These old labels must be removed. This is achieved by pre-soaking, scrubbing and spraying with hot

detergent at 70 °C (160 °F). Detergent is re-circulated. Hot water sprays remove detergent before the kegs leave the washer. External keg washers take up a lot of space and use much energy and water (at least 10 hl/hour at 1.4 bar). The supply of hot water is frequently waste process water and condensate, which may already have been used several times in the brewery. Roller or flat top chain conveyors convey kegs through these machines.

21.5.4 Keg internal cleaning and filling

Kegs are filled with pasteurized beer. Kegs must, therefore, be sterile as well as clean prior to receiving the beer. For this reason cleaning, sterilizing and filling are carried out on one machine called a keg racker. The extractor (spear) remains in place during this operation. On most machines the cleaning takes place with the keg inverted, when the drainage is quicker and more complete and water forced up the spear cleans the side and base of the keg more effectively. In most systems filling also takes place with kegs inverted but any misalignment of the filler and the neck can lead to large beer losses and so sometimes each keg is returned to the upright position for filling (Fig. 21.15). These tasks demand the inclusion in the line of 180° turning machines, which must operate reliably and be of robust construction.

Automatic keg cleaning and filling machines are generally of two basic types, in-line or rotary. In-line machines have a number of 'lanes' at which cleaning, sterilizing and filling takes place in sequence at a series of 'heads'. The number of lanes (typically 8–24) governs the capacity of the machine. The lanes are at right-angles to the conveyor bringing the empty kegs to be filled. In-line machines are often used in the UK and they have to cope with three sizes of keg, e.g., 50 l (11 imp. gal.), 18 imp. gal. and 36 imp. gal. In these machines kegs are fed from one side and leave from the other and proceed in a straight line to the labeller and capper (Figs 21.15a and b). These diagrams show a typical overall layout and the detail of the cleaning and filling operation. A simple two-head machine is shown at which washing takes place on the first head and filling on the second. Recently machines with four heads have been developed to provide a longer cleaning cycle (Carter, 2001). These machines have two washer heads, a sterilization station, a pre-filling head and a filler head. Stringent washing using water and detergent can be carried out. In-line machines can handle frequent size changes and short runs of different beer qualities, though this will considerably reduce efficiency. Downtime on an individual lane will not affect the other lanes and individual lanes can be taken out for maintenance during normal production. Lanes can also be added to an existing machine to increase production. Production rates of 1,200 kegs/h are achievable.

On rotary machines kegs are handled simultaneously on a series of stations in a circular motion around a central core. A typical rotary machine would comprise a washing machine with 24 stations and a filling machine with 12 or perhaps 16 stations (Fig. 21.16a). Rotation times are 65–125 seconds. Kegs are broached once and then rotate with services switching on and off as the kegs move around the circle. Services of water, detergent, steam, carbon dioxide gas and beer and condensate return have to be connected into the centre of the machine. This requires complex sealing with two discs to prevent mixing (Figs 21.16b and c). These machines require less space than in-line machines and are capable of production rates of up to 2,000 kegs/h.

The mechanical design of rotary machines is simpler than in-line machines and downtime is usually less, however, if one part of the machine fails the whole line is

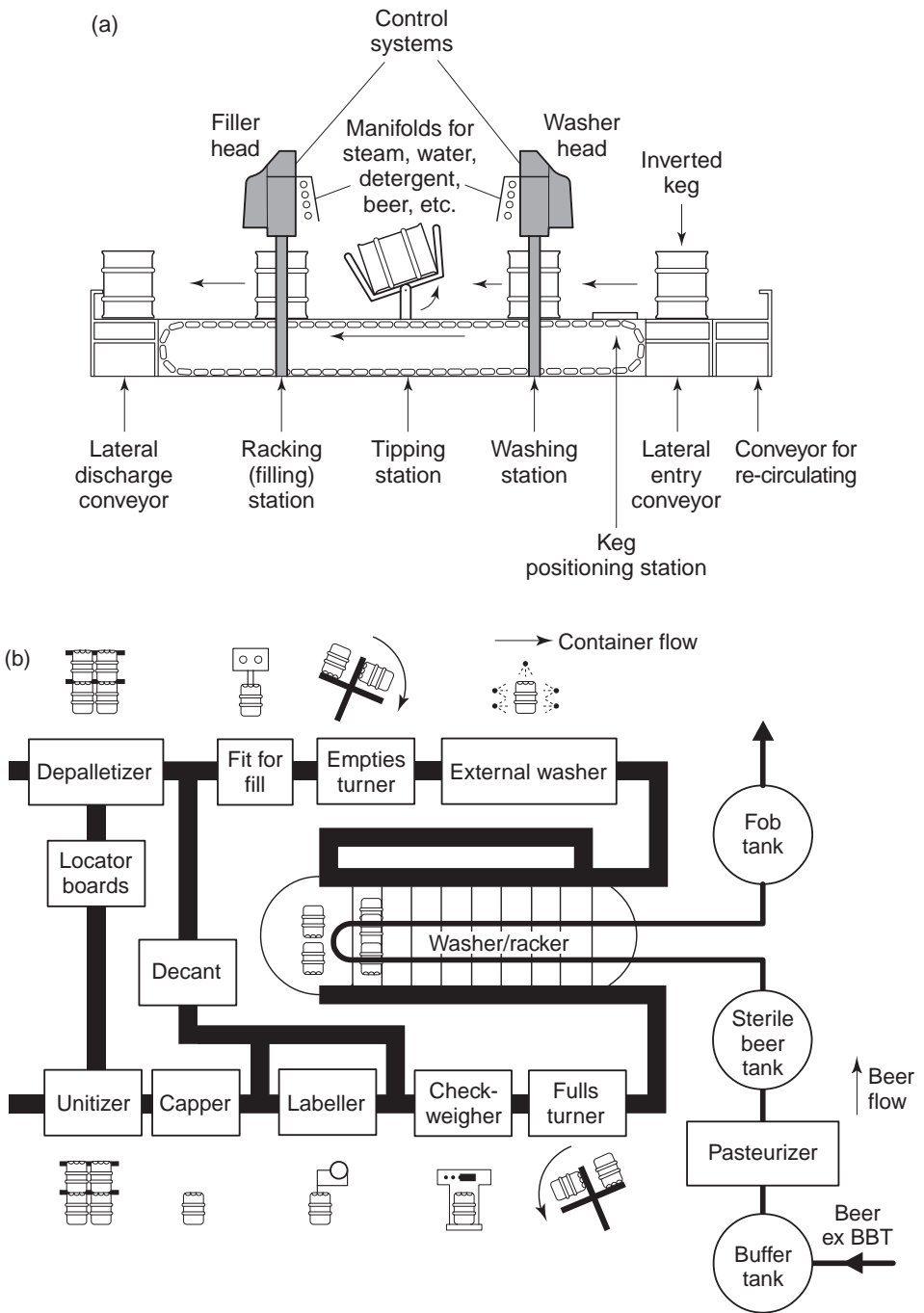

Fig. 21.15 Automatic linear (lane) internal keg washing and filling machine, equipment shown in (a) is found in the washer/racker area of (b) (Eaton, 2002; Hough *et al.*, 1982).

stopped. Rotary machines are not suitable for frequent container size and beer quality changes. In the UK the cleaning agent is usually acid (e.g. 2% phosphoric acid). This allows mixed populations of aluminium and stainless steel kegs to be processed on the same machine. Constant use of acid will lead to build up of protein residues on the inside of the keg and from time to time kegs should be sorted and stainless steel kegs cleaned with caustic alkali. Aluminium kegs can be cleaned with dilute alkali. On the mainland of Europe caustic soda is normally used as stainless steel kegs predominate. On some machines there is the facility to use both acid and alkali in the same cleaning sequence. This is not common practice in the UK.

Table 21.2 Time sequences for automatic cleaning, sterilizing and filling of 50l and 100l kegs on a four-head racking machine (Carter, 2001).

Sequence operation	Time (s) 50 litre	Time (s) 100 litre
Head 1		
Deullage ¹	3	5
Wash 1, recovered water 70 °C	8	15
Air purge	6	12
Wash 2, detergent	18	28
Air purge	7	15
Vent head	1	1
Transfer delays	12	14
Time at head 1	55	90
Head 2		
Wash 3, water 70 °C	20	28
Steam purge 105 °C	7	17
Steam scavenge	8	16
Steam pressurize 1.5 bar	2	3
Head cool	1	1
Transfer delays	17	25
Time at head 2	55	90
Steam hold station		
Steam hold	46	81
Transfer to head 3	9	9
Time at steam hold station	55	90
Head 3 (pre-filler)		
Steam hold	28	28
Steam head	3	3
CO ₂ purge	8	15
CO ₂ pressurize 2 bar	2	3
Vent head	2	2
Transfer delays	12	39
Time at head 3	55	90
Head 4		
Steam head	3	3
Beer fill 4–5 bar	35	70
Scavenge	3	3
Neck wash	3	3
Transfer delays	11	11
Time at head 4	55	90

¹ The process of allowing spent beer in the keg to drain.

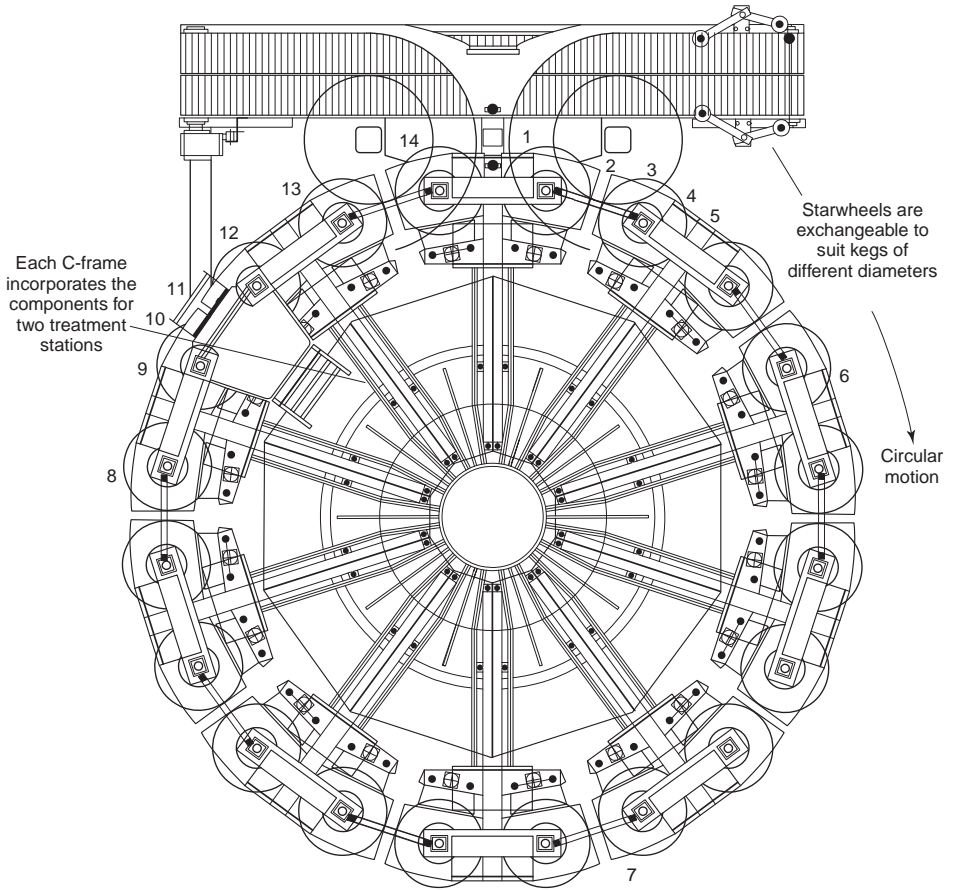

Fig. 21.16(a) A rotary keg racking machine shown in plan from the top. Kegs move around the central core at the series of stations which comprise: 1 cylinder down; 2 leak test; 3 rinse head; 4 blow out head; 5 pressure test; 6 counter-pressure; 7 fill; 8 disconnect; 9 rinse head; 10 pressure relief; 11 cylinder up; 12 close keg; 13 release keg clamp; 14 discharge keg (Eaton, 2002 and courtesy of KHS Till).

Sequences of cleaning, sterilizing and filling vary considerably in practice and for in-line machines will depend on the number of heads on the lane. A typical sequence for a four-head in-line machine is shown in Table 21.2. The washes can be pulsed to give more reliable cleaning and each wash except the final one is purged from the keg with sterile air. The final wash is purged with steam. Effective sterilization and prevention of oxygen pick-up is essential. Steam is used for sterilization. Counter-pressuring with an inert gas such as carbon dioxide is used to keep out oxygen. A temperature of 105 °C (190 °F) must be recorded inside the keg for it to be effectively sterilized. Counter-pressures can be varied but are usually in the range 0.7–3.5 bar (10–50 lb./in.²). Gas is removed down the spear as filling proceeds through the gas ports of the keg. The beer flow is modulated to avoid fobbing, starting and ending at about 10% of full flow. This procedure also allows more precise volume control (see below).

The sequences (Table 21.2) demonstrate the longer time for processing the larger keg. The time sequence will be shorter on a two-head machine but the cleaning and sterilization may not be as effective (Hough *et al.*, 1982). It is advantageous to process long runs of beer into one keg size; frequent changes of size during a shift must be

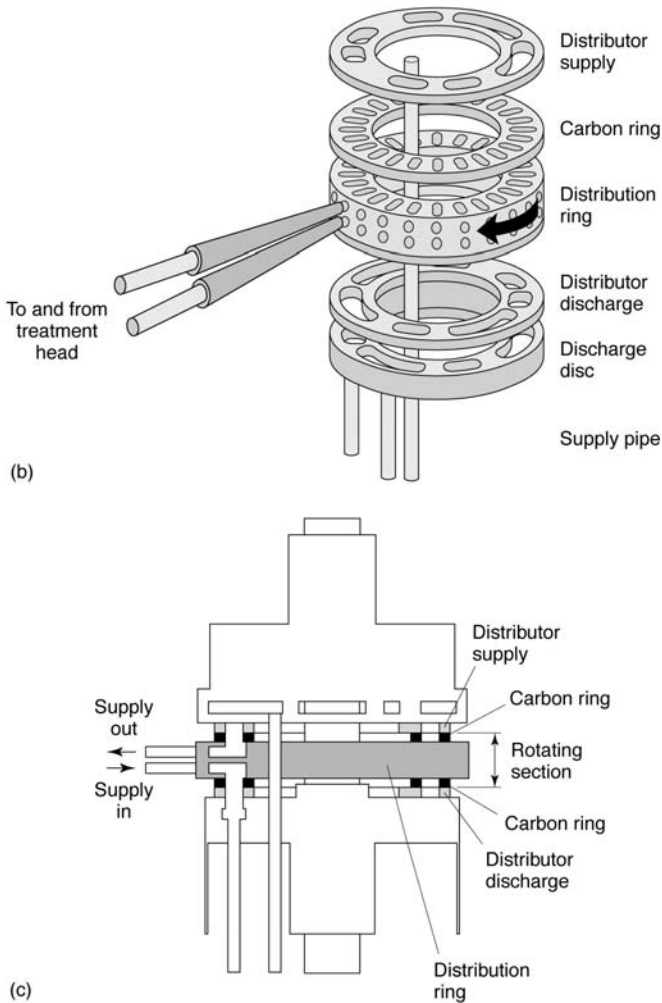

Fig. 21.16(b) and (c) Central distributor of the rotary keg racking machine shown as (b) a schematic block diagram and (c) in vertical section. Each seal for the supply and return of services comprises two discs: a carbon ring and a metal distributor ring. When the holes of the two rings in the rotating section are aligned liquid will flow to the head (Courtesy of KHS Till and Eaton, 2002).

avoided. Washer heads and filler heads have manifolds for detergent, water, steam, carbon dioxide and beer. All these mains must be cleaned and steam sterilized before beer is passed through. Keg plants require frequent cleaning. This can take up to six hours twice a week depending on the volumes of beer being processed. After filling, the Barnes neck is usually air-dried, though this step is sometimes omitted, and the keg proceeds to be capped and labelled. These tasks were traditionally manual but machines are now available for automatic capping and labelling.

A major factor in filling is an accurate determination of the contents of the keg. This is required by statute in most countries and is subject to audit. There are two requirements: the contents must meet a prescribed amount so that the customer is assured of receiving the appropriate volume and is not defrauded, and containers must not be consistently overfilled or the correct amount of excise duty will not be paid. Control of volume to

meet these criteria is not easy. A gross and tare weighing system can be used with success on smaller volumes but this system has been unsuccessful with barrels (36 imp. gal. containers) still in use in the UK. A volumetric control is preferred although recently other devices have been described (Carter, 1998; Brewer and Carter, 2000).

An on/off beer filling valve can give a keg brim fill to $\pm 0.5\%$. This can be improved to $\pm 0.25\%$ with an electro-magnetic flow meter (Carter, 1998). More advanced systems (Brewer and Carter, 2000) incorporate a modulating back pressure valve with the flow meter. This system delivers pressure profile filling with a precision of $\pm 0.02\%$. No mechanical valve is required to regulate flow and 100 l/min. is achievable. A slow initial fill is possible, which reduces carbon dioxide breakout and the potential for oxygen pick-up. After the speeding-up of the flow a quiet cut-off ensures low carry-over into the extractor tube and the retention of internal pressure. Other developments incorporate an inductive flow meter in a direct flow control filling head (*International Bottler and Packer*, 2000). The keg is counter-pressured with 1.4 bar (20 lb./in.²) carbon dioxide or mixed gas and the flow meter coupled with a valve allows an exact pre-set amount of beer into the keg. A sensor in the return gas pipe keeps the counter pressure gas, and so the fill rate, constant.

Filling by weight can be achieved using load cells incorporated into the line. Many keg lines incorporate a check-weigher to determine satisfactory operation of the volumetric system. A weighing platform fits within the conveyor and under-weight kegs are rejected, usually by a pneumatic ram onto a reject line.

21.5.5 Keg capping and labelling

A plastic cap is applied to the Barnes neck to protect the filling and dispense valve from dirt and to deter tampering. A number of designs are available. Some caps are formed in the applicator machine whilst other cap types are supplied with an appropriate logo affixed by the manufacturer. Automatic machines must be capable of 125% of the rate of the filler so as not to be rate limiting in the overall process. Some caps attach by shrinking and some by clipping to the neck of the keg. The most important aspect is the degree of security it provides against interference.

Labels on kegs are important in providing the customer with information as to the beer quality in the keg and its 'best-before' date, and the brewer and the customer with complete traceability of the container. Barcodes applied to paper labels are essential to contain this information. Machines are now available which, when programmed, print and subsequently apply the labels to the containers. Quality of printing and application is now high. (*International Bottler and Packer*, 2000). Barcodes can contain the sequential number of the container in the packaging run as well as the quality and best-before date. These barcodes can be scanned at various points in the supply chain, e.g., at despatch, on the delivery vehicle, at the selling point and on return to the brewery. These labels must be removed prior to reuse of the keg. This means that the labels can be damaged and made unreadable during the supply chain history of the container.

Containers frequently disappear and the paper label will not protect against this. Brewers have sought more innovative solutions to the problems of container management and traceability. In some systems the entire population of kegs is handed over to a third party who, for a fee, manages the population, thus reducing the capital employed by the brewer (Nelson, 2000b). Radio frequency identification tags can be embedded into the keg, which identify the keg as a unique container throughout its whole life history. This

could be an extremely valuable system if it could be coordinated on a national (or even international!) scale between competing brewers. Progress on this in the UK has been slow. Probably further developments will occur in ways of tracking containers, because of the desire for complete traceability for quality assurance and because of the high cost of containers (approx £40/container).

21.5.6 Smooth flow ale in kegs

As stated earlier, beer for kegging is normally conditioned prior to pasteurization to a carbon dioxide content of 1.5 to 2.5 vol/vol. Pasteurization and filling must then be managed to maintain this carbon dioxide concentration. In an analogous way to the development of the widget in canning (Section 21.4.5) there is a desire in the UK and Ireland to produce keg beers with the drinking characteristics of cask ales. This demands a carbon dioxide content of around 1.0 vol/vol and a thick creamy head. The use of nitrogen gas provides a solution (Carrol, 1979). The problem with keg beer is getting the nitrogen into the beer and keeping it in solution through packaging and up to the point of dispense. Nitrogen can be introduced into a roused bright beer tank at the inlet through a sinter. The tank will be top pressured with nitrogen and considerable manual involvement will be needed to achieve a satisfactory result (Fitch, 1997). The carbon dioxide content of the beer must be known and, since the nitrogen is being added before the flash pasteurizer, the pasteurizer must have the pressure capability to keep nitrogen gas in solution as well.

An improvement is to use a mass flow system. A measurement is made of the initial carbon dioxide and nitrogen contents of the beer (which should be below specification) and both gases are added. Turbulent flow in the pasteurizer ensures good mixing and the boost pump of the pasteurizer system provides sufficient pressure to prevent gas break-out. This system demands very careful control of the operating pressures to achieve the desired level of nitrogen consistently. In the 'Nitroset' system (Lindsay *et al.*, 1995) nitrogen is injected directly into the beer after the pasteurizer. A boost pump can achieve 15 bar (220 lb./in.²) pressure to keep the gas in solution (Fig. 21.17). Accelerator mixers create further turbulence to aid solution. Variable flow rates of between 150 and 450 hl/h are achievable. Nitrogen concentration can be determined pre- and post-addition with 'Orbisphere' thermal conductivity nitrogen monitors.

Further techniques have been described using hydrophobic membranes (Gill and Meneer, 1997). The membrane is in the form of a hollow fibre, which allows gas to diffuse into or out of a liquid without the need for intimate mixing. Each membrane comprises a bundle of fibres with the gas on the inside and the liquid on the outside. Gases can be exchanged into or out of the liquid by varying the partial pressure and gas composition on the inside of the fibres. Pilot scale work has been carried out and scale up to 500 hl/hour has been claimed to be feasible. This technique could be valuable for both the addition of nitrogen and the removal of carbon dioxide, particularly if this could be achieved by a single pass through the gas exchanger. At present direct injection systems are the most widely used.

Nitrogenated beer has both carbon dioxide and nitrogen in solution and these gases must be kept in solution at the appropriate concentrations up to the point of dispense of the beer (Chapter 23). Dalton's Law demands that the same two gases must be in the head space of the tank or the keg in the same balanced proportions. The beer can therefore be filled into the keg using the mixed gas proportion of dispense or, for very low carbon dioxide beers (< 1 volume), 100% nitrogen can be used.

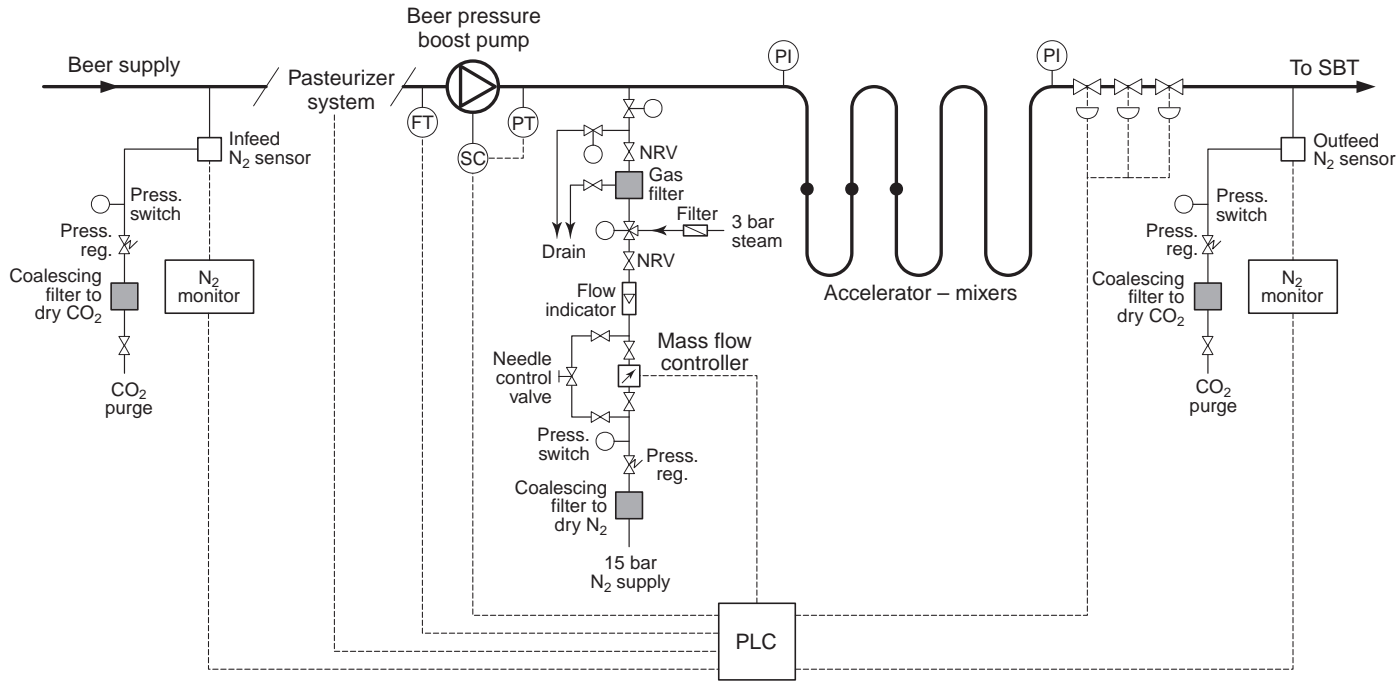

Fig. 21.17 Flowsheet for the 'Nitroset' beer nitrogenation system: FT flow transmitter; SC speed controller; PT pressure transmitter; PI pressure indicator; NRV non-return valve; PLC programmable logic controller; SBT sterile beer tank (Lindsay *et al.*, 1995).

A typical ‘smooth-flow’ English ale would have a dissolved gas analysis of:

- nitrogen (mg/l) 35 (Range 32 to 38)
- carbon dioxide (vol/vol) 1.1 (Range 1.0 to 1.2).

In the UK virtually the whole of the keg ale trade is in high nitrogen, smooth flow beer. There is virtually no interest in this type of beer in other parts of the world. There have been lagers packaged at high nitrogen levels in the UK. These have not been entirely successful because of the need to maintain a significant carbon dioxide content (say 2.2 vols) to achieve the sparkle typical of good lager. The nitrogen ‘softens’ the flavour so that the pleasure of drinking a sharp, effervescent lager is lost.

21.6 Cask beer

The final type of packaging to consider is the packaging of naturally conditioned beer into casks. This beer is not filtered and stabilized in the brewery. It contains live yeast and depends on a secondary fermentation in the cask to provide condition (carbon dioxide) to the beer before it is drunk. The beer is not served under pressure and is dispensed by hand pumps (Chapter 23). This type of beer is produced in large volumes only in the UK. Of the 59 million hl of beer produced in the UK in 1998, 38 million hl were sold in draught form and of this volume 11%, about 4.2 million hl was cask beer. Originally beer was filled (racked) into casks made of wood. These are now rare and almost all casks are stainless steel or aluminium.

Cask beers tend to be rich in flavour and aroma, particularly those flavours associated with hops and this makes them unique and much sought after by some drinkers. The advantages to the brewer of producing cask beer relate to the relatively low cost of the equipment needed and the low energy input. Disadvantages include the inherent variability of the product, its proneness to infection if consumed slowly and the skill required of the publican to dispense it properly (Chapter 23). Some brewery marketing departments do not like these attributes of cask beer and are more comfortable with the predictable behaviour of keg, bottled and canned beer. As a consequence most ale brands in the UK are sold in keg as well as cask form and for some brands the relative volumes are much more in keg. This trend has been resisted by a consumer organisation called CAMRA – the Campaign for Real Ale. This is a powerful pressure group and has done much to persuade brewers to continue to produce high-quality cask beers. Most brewers seek to develop good relationships with their local CAMRA branch. CAMRA operates in all areas of the UK.

The issues involved in producing sound cask beer revolve around the handling of the casks and the handling of the beer.

21.6.1 The cask

Casks are not pressurized containers and are simpler in construction than kegs (Fig. 21.18). Casks contain a hole on the top of the belly called the shive hole that is protected by the shive boss. Through this hole the cask is filled and then closed with the shive, which can be made of wood or plastic. A second hole on the end of the cask is stoppered with a plug called a keystone prior to filling. This plug is usually made of wood and through this plug is driven, where the beer is to be served, the tap from which the beer leaves the cask to be drunk (Chapter 23). Casks are usually of 9, 18, or 36 imp. gal.

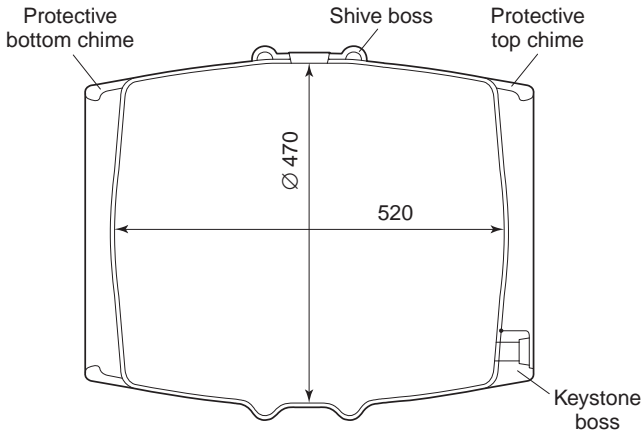

Fig. 21.18 Vertical section of 18 imp. gallon beer cask, height, 520 mm; diameter, 470 mm (by courtesy of Alumasc Ltd).

capacity. In the 1970s much beer was sold in hogsheads (54 imp. gal.) but these are now very rarely seen.

21.6.2 Handling casks

Equipment for handling empty and full casks and removing them and stacking them on pallets or spacer boards is identical to the equipment used for kegs. In small breweries (< 1,000 imp. brl/week; 1,600 hl) there will be much more manual handling. To achieve efficiency in filling, only those casks 'fit to fill' should proceed down the line to the racker. Making casks fit to fill requires the removal of beer and hop residues (ullage), the removal of the old label and external washing of the cask, and the removal of the shive and keystone. Until recently these tasks were almost always performed manually with consequent high demand for labour. Vision systems, sometimes using lasers, have now been developed (*International Bottler and Packer*, 2000) which automatically locate the position of the shive and the keystone, facilitating their removal by screws, which bore into the wood or plastic and then lift the remainder of the shive or keystone clear of the cask. Hot water and brush systems will remove labels and clean the outside of the cask.

The most important machine prior to filling is the internal cask washer (Fig. 21.19). These machines are of very robust construction to withstand the weight of the casks and the frequent turning required to ensure effective cleaning. The filling of cask beer is not an aseptic operation but the internal surface of the cask must be as clean as possible and practically nearly sterile to prevent the growth of bacteria and hence the development of 'off' flavours. Cask washers vary in design but the main agent in achieving effective cleaning is the hot water used. A temperature of at least 80°C (175°F) is needed and pressure of the sprays needs to be about 70 bar (1,000 lb./in.²). Caustic alkali and/or acid can be used but effective cleaning is possible with water alone provided the temperature is correct. A frequent problem in cleaning is the removal of wood from pieces of keystone and shive, which entered the cask when broached. This has resulted in the use of plastic shives but keystones are still mostly made of wood. From time to time casks must be taken off-line for inspection and manual removal of wood.

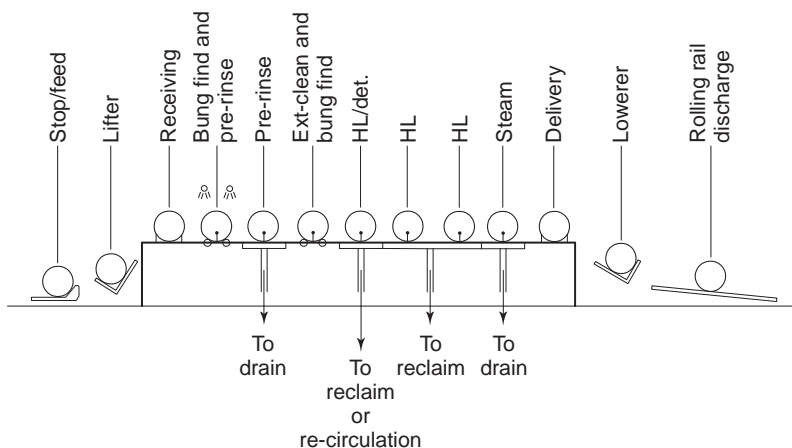

Fig. 21.19 Internal cask washing equipment: nine station chain machine with moving centre beam; HL, hot liquor (water); det, detergent applied to outside of cask (not used in all installations) (by courtesy of Porter Lancastrian Ltd.).

21.6.3 Preparing beer for cask filling

Cask beer contains live yeast and an important aspect of preparing beer for the cask is controlling the yeast count at racking. Beer can be racked directly from the fermenting vessel after skimming and an appropriate settling time, but with this arrangement it is difficult to get a consistent control of yeast count. After fermentation beer is usually run into racking tanks or backs. In these tanks the beer is given a time to settle, 16–48 h, depending on the state of the beer and demand from trade. The yeast will partly settle. The objective is to achieve a yeast count at rack of around 1 million cells/ml of beer. The range of yeast count at which cask beer can be successfully packaged is from 0.25 to 4 million cells/ml, but nearer to 1 million is to be preferred. Too much yeast suspended in the beer will result in a violent secondary fermentation and when the casks are vented prior to sale beer and foam will gush from the cask and will be lost (Chapter 23). The remaining beer will be dull and lifeless and will have little to no head retention or foam character. If too little yeast is present the secondary fermentation will be too slow and there will be insufficient carbon dioxide in the beer at dispense with the consequence of a flat, lifeless beer.

Settling controls yeast count but to aid this process, finings are used (Chapter 15). Isinglass finings are added at the rate of 1 to 4 pints/imp. brl (0.36–1.44 l/hl). These finings can be added in the racking tank or at any point up to when the beer is dispensed. The usual point of addition is at rack with perhaps a prior addition in the racking tank. In any event the beer will require from 12–48 h and possibly up to 72 h to fine and settle before it is sold. The fining of cask beer is one of the most difficult of all brewery operations to control consistently. Often brewers experience periods of poor fining which are difficult to explain. Isinglass finings bear a positive charge because of the rich collagen content and interact with the negative charge on the yeast cell wall. In most circumstances this interaction is sufficient to achieve effective clarity.

Some beers, sometimes will not fine with isinglass alone. The yeast may have a too low negative charge or the concentration may be too high (say > 2 million cells/ml), or there may be too high a concentration of positively charged colloids in the beer. In this

situation auxiliary finings derived from alginates, carrageenan or silicic acid, and having a negative charge, can be added to the beer before isinglass finings to precipitate the positively charged colloids (Vickers and Ballard, 1974). An effective method is often to add the auxiliary finings in the racking tank and separate the flocs thus formed in this vessel and then to add the isinglass at the rack of the beer. Priming sugars are also added to some beers at this stage. These are normally solutions at 1150 °Sacch (37 °P) and are added at rates of 1 to 5 pints/barrel (0.35–1.75 l/hl). The priming sugar provides a small quantity of fermentable carbohydrate (often sucrose) to assist the yeast to achieve effective secondary fermentation in the cask.

The pH value of cask beer is usually in the range 3.90–4.20. Some brewers add potassium metabisulphite to beer, which has a bacteriostatic action at pH values below 4.20. This can give some protection against infection but is not a substitute for good practice in cask washing and filling.

21.6.4 Cask filling

The size of breweries producing cask beer varies considerably from those producing national brands at over 5,000 imp. brl (8,000 hl)/week to those producing less than 100 imp. brl (160 hl)/week. Further, micro-breweries or pub breweries may produce only enough beer to be sold in their own premises and this may be only 1–10 brl (2–150 hl)/week. This means that cask filling operations can vary from single head manual fillers to large, multi-head racking machines.

Cask beer has a shelf-life from packaging to consumption of a maximum of four weeks. It contains considerable quantities of yeast, which provides protection against flavour defects which might be attributable to excess oxygen. While the elimination of oxygen ingress during packaging is not as critical as with the packaging of brewery conditioned beers, it is minimized. Modern cask racking machines usually incorporate a stage of counter-pressure with carbon dioxide gas.

After washing, casks are conveyed by roller or flat chain conveyor to the racking machine. Prior to racking a keystone is driven into the cask. The casks are rotated belly-up so that the shive hole is vertically uppermost. The cask is located beneath the filling tube at a 'head' on the racker (Fig. 21.20). There may be up to eight heads on the racker and therefore up to eight casks can be filled simultaneously. The filling tube will

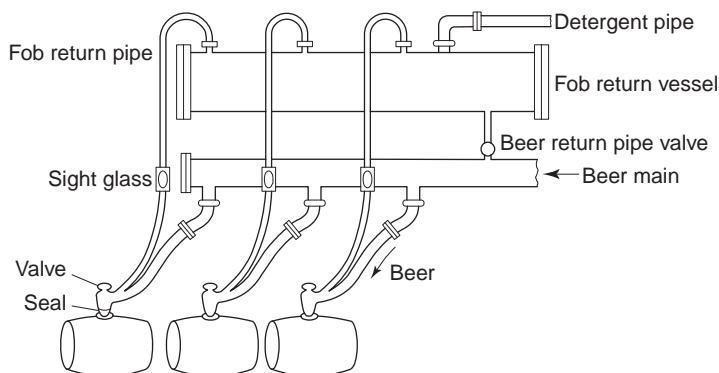

Fig. 21.20 Traditional cask ale racking back (Hough *et al.*, 1982).

comprise a tube for the beer and a tube for carbon dioxide gas and this is lowered onto the shive hole to make contact with the cask, which is so sealed from outside air. The cask is first counter-pressured with carbon dioxide, the bottom valve is opened and the beer then flows at atmospheric pressure into the cask. Air/carbon dioxide in the cask flows through the return air-pipe, which usually contains a sight glass. The cask is deemed to be full when beer can be seen in the return air-pipe.

Fillers controlled by a volumetric meter are also available. The beer supply is then shut off and the filling head is raised. Beer in the return air-pipe is evacuated to a fob tank and can be added to a following cask. This requires scrupulous attention to the cleanliness of the mains, as this procedure is a frequent source of infection to the cask beer. However, if this beer is not returned losses will be high. After raising the filling tube the cask is closed by manually driving a shive into the boss. Isinglass finings (1–4 pints/imp. brl) can also be added at this stage when the beer is said to have been ‘fined at rack’. This is now usually the case in the UK because tax (duty) on the beer is paid on the volume and strength of the beer leaving the brewery and this cannot be controlled if the cask is broached for fining in a depot or at the point of sale.

Cask beers are renowned for hop character and this derives from the particular hops used in the copper and also from the practice of dry-hopping beers on the racker so that hop aroma can develop in the cask in its period of storage prior to dispense. Dry hops are usually added in the form of pressed pellets at rates of 0.5–6 ounces (14–84 g)/barrel. The pellets are formed from whole cone hops and are lightly pressed to avoid rupture of lupulin glands (see also Chapters 7 and 8). They are supplied in weights of $\frac{1}{4}$, and $\frac{1}{2}$ ounce (7 and 14 g). The pellets have a short shelf-life and should be kept at below 15 °C (60 °F) and a batch should be used in four months. The pellets are added by hand prior to closing the cask with the shive. The weight of the pellets and hence the essential oil content is very variable. This has led to the development of various extracts in which more consistent levels of essential oil can be added (Chapter 7). These products are, however, difficult to handle on the line, are expensive and have not enjoyed wide favour with brewers particularly as the sales of cask beer are in decline. Many different hop varieties have been used for dry-hopping and particular varieties are favoured for particular beers. These can be as diverse as East Kent Goldings, Fuggles, Wye Northdown and Styrian Goldings. Brewers should pay particular attention to securing adequate supplies of hops for several crop years ahead to ensure beer flavour is not compromised.

After filling the cask is labelled. The comments made on the labelling of beer in kegs (21.5.5) equally apply to beer in casks. To ensure that the beer is in optimum condition when drunk requires considerable effort in storage and dispense (Chapters 22 and 23). In the UK cask beer remains a favourite choice of experienced drinkers but its wider appeal is limited by inherent inconsistencies and the desire to drink beers at lower temperatures (< 8 °C; 46 °F), which seriously limit the flavour experience of the true cask product.

21.7 Summary

Packaging is a vital part of brewery operations. The rise in the drinking of beer at home and the influence of retail supermarkets has meant that effective packaging of beer in bottles and cans is essential to catch the eye of the purchaser. Huge amounts of money are

spent by global brewers on packaging developments, certainly much more than is spent on research into processing or raw materials.

In many parts of the world the major package remains the returnable bottle. But local brewers are in competition with the brewers of international brands putting their traditional markets under threat by more sophisticated packaging. This has resulted in a raising of standards of packaging to preserve the market for local beers.

Even with draught products there is a greater demand by customers for cleaner containers and for labels providing more information about the quality of the beer and its shelf-life. Concurrently the brewer has made efforts to improve the traceability of beer in kegs or casks, to protect his investment in the container and to ensure that the customer is protected in any cases of poor quality.

Brewing becomes increasingly a trans-national business and it is likely that as markets develop the trend will continue towards packaging in non-returnable bottles, probably made of plastic. This will increase the pressure on finding effective ways of recycling the empty package.

21.8 References

- ATKINSON, B. (1988) *J. Inst. Brewing*, **94**, 261.
- BEER, C. (1989) *Tech. Quart. MBAA*, **26**, 89.
- BLRA (2002) *Statistical Handbook*, Brewers' and Licensed Retailers' Association, London.
- BREWER, A. J. and CARTER, A. (2000) *Tech. Quart. MBAA*, **37**, 105.
- BROWN, D. (1997) *The Brewer*, **83**, 25.
- BUNKER, H. J. (1955) *Proc. 5th Congr. Eur. Brew. Conv., Baden-Baden*, 330.
- BUSH, J.H. (1964) *Brewers' Digest*, **39**, 48.
- CARROL, T.C.N. (1979) *Tech. Quart. MBAA*, **16**, 116.
- CARTER, A. (1998) *Proc. 25th Conv. Inst. Brew. (Asia Pacific Section)*, Perth, 114.
- CARTER, A. (2001) Personal communication.
- COLEMAN, M. (1976) *Brewers' Guard*, **105**(10), 51.
- DEL VECCHIO, H. W., DAYHARSH, C. A. and BASELT, F. C. (1951) *Proc. Ann. Meet. Amer. Soc. Brewing Chemists*, 45.
- DONHAUSER, S. and JACOB, F. (1988) *Brauwelt*, **128**, 1452.
- DONOVAN, P., CURRIER, R., BLANTON, R. and ROSS, J. (1999) *Tech. Quart. MBAA*, **36**, 247.
- DUFFY, G. and DU TOIT, C. (2000) *Tech. Quart. MBAA*, **37**, 285.
- EATON, J. B. (2002) Personal communication.
- EVERETT, J. F. (1997) *MBAA. Beer Packaging Manual*, 167.
- FITCH, N. (1997) *Ferment*, **10**(1), 41.
- GILL, C. B. and MENEER, I. D. (1997) *The Brewer*, **83**, 77.
- HEINS, H. and HEUER, J. F. (1997) *MBAA. Beer Packaging Manual*, 249.
- HEUER, J. F. (1997) *MBAA. Beer Packaging Manual*, 274.
- HOUGH, J. S., BRIGGS, D. E., STEVENS, R. and YOUNG, T. W. (1982) *Malting and Brewing Science*, Chapman and Hall, New York, 721.
- HYDE, A. (2000) *The Brewer*, **86**, 248.
- International Bottler and Packer*, (2000) February, 40.
- KUNZE, W. (1999) *Technology Brewing and Malting*, VLB Berlin, 460.
- LANDMAN, B. C. J. (1999) *Tech. Quart. MBAA*, **36**, 329.
- LINDSAY, R. F., LARSEN, E. and SMITH, I. B. (1995) *Proc. 25th Congr. Eur. Brew. Conv. Brussels*, 705.
- MOLL, M. (1994) *Beers and Coolers*, Intercept, Andover, Hampshire.
- MOLL, W. A. (1997) *MBAA. Beer Packaging Manual*, 83.
- NELSON, L. (2000a) *Brewers' Guard*, **129**(2), 25.
- NELSON, L. (2000b) *Brewers' Guard*, **129**(6), 26.
- PALL, D. (1975) *Brygmesteren*, **32**, 197.
- PARSONS, M. (2000) *The Brewer*, **86**, 347.
- PASTEUR, L. (1876) *Études sur la bière*, Gauthiers Villars, Paris.
- RAINBOW, C. (1971) *Process Biochemistry*, April.
- ROUILLARD, C. (1999) *Tech. Quart. MBAA*, **36**, 435.
- ROUILLARD, C., and HOWELL, M. (1999) *Tech. Quart. MBAA*, **36**, 243.
- SCHWARTZ, V. (1997) *MBAA. Beer Packaging Manual*, 192.

- SCRUGGS, C. E. (1997) *MBAA. Beer Packaging Manual*, 226.
- SPARGO, W. (1997) *MBAA. Beer Packaging Manual*, 149.
- VICKERS, J. C. and BALLARD, G. (1974) *The Brewer*, **60**, 19.
- WAINWRIGHT, T. (1999) *Ferment*, **12 (6)**, 4.
- WILLOX, I. C. (1966) *J. Inst. Brewing*, **72**, 236.
- WILSON, J. R. (1997) *MBAA. Beer Packaging Manual*, 352.
- YEO, A. (2000) *Brewers' Guard*. **129 (6)**, 22.
- YOKOI, T., SASAKI, T. and KURAHSHI, M. (1991) *Tech. Quart. MBAA*. **28**, 12.

Storage and distribution

22.1 Introduction

It was commonly the practice to deliver beer from breweries directly to customers. This was the case in the UK and parts of Europe from the time of the Industrial Revolution until well into the 20th century. This was not the case in North America where the distances to be covered were much greater. The principles of the storage and distribution of beer are governed by the nature of the customer, the distances involved in the delivery and the type of beer. In large breweries the organization of storage and distribution is frequently the responsibility of an entire department, which may even be located away from the brewery site. As the brewing industry has become more competitive so the storage and distribution of beer has to be carried out with the utmost efficiency and at lowest cost. The likely long-term winners will be the companies who pay most attention to getting good quality beer to the customer when he wants it, not when it is best for the brewery to deliver. This has resulted in companies adopting the principles of logistics, derived from military experience, to ensure optimum deployment of stock and vehicle movement.

22.2 Warehousing

Brewing is a capital-intensive business, which involves both fixed assets and working capital. A major part of the working capital is the stock of finished goods held at the brewery. Beer deteriorates with age and so stock levels should be held as low as is possible consistent with delivery to meet customer requirements. In this way the customer gets fresh beer and the return on capital employed is enhanced.

In most countries, governments take an excise tax on beer so the value of the stock depends to a large extent on whether it is held as tax paid or tax suspended. In duty systems where the beer is taxed 'at the brewery gate' the beer in the brewery store is held duty suspended where it might be held duty paid in a store when it has exited the brewery. It makes financial sense to minimize overall stock and maximize duty un-paid stock.

Brewing companies have become expert at this but the demands of customer service have become more important as breweries seek to establish competitive advantage. This has tended to result in higher stocks of some products being held in order to avoid any possibility of stock-outs. The demands on the effective management of the brewery warehouse have, therefore, increased. Breweries will have a warehouse situated as close as possible to the end of the packaging lines. Frequently there is a seamless transition from packaging to warehouse and these parts of the brewery may be under the same management. This avoids disputes as to the rate-limiting steps in the sequence of operations from packager to customer.

Warehouses vary in complexity in relation to the number and types of products stocked. This can include beer in casks and kegs as well as numerous sizes of bottles and cans in various package types. This complexity is judged in terms of stock keeping units (SKUs). Each type of package is one SKU. Beer of the same specification in bottles of 25 cl, 33 cl, and 50 cl is 3 SKUs. This would further proliferate if those bottles were packed into boxes containing 15, 18, or 24 bottles, which might be needed for different customers. Soft drinks might also be handled as well as beer. The number of SKUs can reach very high levels very quickly. This puts great emphasis on stock control and the organization of production to meet diverse demands.

Warehouses also have to deal with empty containers returned from trade. These will include kegs and bottles in most cases. These will require sorting and cleaning (Chapter 21). Warehousing, therefore, relates to the storage and despatch of beer, and the reception, storage and issue of packaging materials. These packaging materials can be quite simple in a warehouse dealing only with large pack beer in cask or keg but extremely diverse in a warehouse storing small pack beer in bottles or cans in various types of shrink wrapping and boxes, cardboard cases and crates.

22.2.1 Principles of warehouse operation

Warehousing requires a large amount of space and the multi-handling of packages. No matter how low the stock holding, warehousing is expensive, so the area required, though large, must be kept to a minimum by stacking containers and packages on robust pallets or by using undamaged spacer boards when handling containers palletless. Space must be utilized carefully to minimize the extent of mechanical handling by forklift truck. Computer systems are widely used to manage the inventory in the warehouse. Information can be fed to the computer from radio data terminals on the forklift trucks and entries made as beer comes off the packaging line into store and leaving the warehouse floor onto a vehicle.

Stock control

Beer deteriorates with age and will have a defined shelf-life that can vary from four weeks for cask beer to 52 weeks for highly stabilized beer in bottle or can. It is essential that stock must be rotated on a 'first in first out' basis. Most breweries have strict rules about the age of beer that may be released to a customer, to ensure optimum quality when the beer is drunk. The exact age on release will depend on how much stock is held in depots or regional distribution centres. This illustrates just how critical careful stock control is to the success of the brewery. Beer that goes over age in the warehouse must either be destroyed (which has implications for excise duty) or recovered and blended back at, say, 5% into mainstream beer. These are both expensive operations.

Storage conditions

Conditions in the warehouse are critical for beer quality. Filtered beer must be stored above freezing point and at $< 22^{\circ}\text{C}$ ($< 72^{\circ}\text{F}$). At low temperatures a chill haze may develop and at temperatures greater than about 22°C (72°F) flavour stability is threatened. The storage of cask beer is more critical because of the presence of live yeast and the required secondary fermentation, which continues in the pub cellar. Cask beer is best stored between 10 and 17°C (50 and 63°F). Relative humidity must be kept low by adequate ventilation. Moist conditions promote the deterioration of secondary packaging on cases of bottles and cans and render the beer unsaleable. There must be high standards of housekeeping. There should be written hygiene procedures that must be adhered to. In this way pests such as mice, pigeons and cockroaches will be deterred.

Record keeping

In most countries the tax (duty) on beer is paid when the beer leaves the warehouse. It is a legal requirement to maintain records of the volume and strength of the beer being made and subsequently sold. These records must be available for inspection and audit at any time. Governments also usually have legal requirements relating to the volume of beer sold in packages, which may be related to minimum or average contents. This again requires record keeping.

Product traceability in trade is now important. Customers are more demanding of product quality and are frequently encouraged to voice their opinion of the beer by telephoning help lines. It follows that there must be very sound systems in place for labelling containers and subsequently tracing the beer's history in the brewery, the warehouse and in the trade.

22.2.2 Safety in the warehouse

The warehouse is one of the most dangerous places in the brewery, where frequently the highest numbers of accidents occur. This is a result of the juxtaposition of forklift trucks and the manual handling needed to get the beer in the right place. In the UK the highest incidence of 'lost-time accidents' is in warehouse and distribution work (BLRA, 1987–1995). In the period 1987–1991 there occurred an average of 1,000 accidents each year resulting in lost time of more than three days. Of these over half were associated with handling, lifting or carrying beer in its various containers. This resulted in the introduction of 'Manual Handling Regulations' in 1993. There are similar regulations in place in other countries. The basic principle of these regulations is to control risk so far as is reasonably possible:

- avoid hazardous manual handling where possible
- assess any hazardous operations that cannot be avoided
- remove or reduce the risk of injury so far as is reasonably practicable using the assessment as a basis for action.

These regulations place a duty on employers and employees with the objective of reducing the number of accidents and creating a safer workplace. The employer must have a safe system of work, which is written down, monitored, audited and improved. Training discharges the responsibility of employers for much of this. The training must be ongoing and this can place a considerable strain on resources of both trainer and employee. The rewards are, of course, considerable as the 'lost time' of the accidents can be reduced with big savings in cost and improvements in customer service and greater well-being of employees.

22.3 Distribution

Distribution is one activity that has been subjected to intense scrutiny and change in recent years. This is particularly the case in countries with mature beer markets in Europe and North America. In these areas beer consumption in the early 21st century is falling or at best is static. Competition between companies is intense and all companies seek to call themselves to the attention of the customer to gain a competitive advantage, however small. Product quality is of paramount importance. It is simply not possible to sell beer that is not of the highest standard. It is very difficult, therefore, to gain advantage on the basis of product quality. There will be differences in beers between brewers but the quality will be very similar. Likewise, low-cost production has become almost a given requirement for the national and international brewer. The definition of low cost will vary from country to country but competitors know the targets in any particular country and will measure their performance against those targets by benchmarking to ensure that costs are under control. It is therefore very difficult to gain advantage on the basis of the cost of production.

The brewing industry was slow to understand the significance of customer service. In the UK this was certainly a result of the ownership of the retail outlets for beer. These outlets were, in the main, in the hands of the brewers of the beer until the report of the Monopolies and Mergers Commission into restrictive practice in the brewing industry was published in 1989. Before this time there was little incentive to devote too much time to the needs of the customer when that customer was a public house owned by the brewery. Everything changed when restrictions were placed on the number of retail outlets that could be owned by beer producers. Competition intensified overnight. Different pressures applied in other countries of the developed world. One of the main factors was a major increase in interest in 'healthy life-styles' that occurred in the USA and Europe from the early 1980s. Beer sales fell and brewers realized they were not only in competition with each other but with manufacturers of soft drinks. A competitive advantage was needed and brewers looked to customer service to provide it. Much effort was therefore put into distribution and to understanding the needs of the customer. In countries where beer consumption is still growing rapidly, such as China, and parts of South-East Asia and parts of South America, distribution is still important but it is unlikely to be the main agent of competitive advantage.

22.3.1 Logistics

Beer supply in breweries was formerly in the hands of a transport department that then became known as distribution. The controlling interest was frequently the maintenance of the vehicles rather than the requirements of the customer. Management was mainly concerned with load planning, i.e., ensuring the optimum weight of beer on the vehicle and ensuring the most efficient route to conserve fuel. The use of logistics is concerned with optimum deployment of stock and vehicle movement. This implies the integration of planning and distribution. The driving force can now be the customer because the optimization can start with the customer needs and stock deployment can be built around this. Thus the 'pull' style of planning develops, starting with the customer requirement and finishing with scheduling the number of brews per week in the brewhouse.

There has generally been a big increase in the demand for small pack beer for consumption at home (BLRA, 1999), usually bought through supermarkets. This has introduced a new customer service dimension and one that has brought the producer

much closer to the consumer. To meet this diverse demand regional distribution centres away from breweries have been set up in the UK and have developed in other parts of Europe. Regional distribution was always a feature of North American distribution because of the great distances involved and customer service was part of the North American brewer's way of life earlier than it was in Europe.

Planning

The core of successful logistics is planning. The requirements of the customer must be interpreted into plans that can deliver the right amount of stock at the right time and efficient production of that stock by the brewery. The plan is derived from historical sales data and forecasting. The former is a matter of fact and the latter is frequently a matter of conjecture! Software systems are, however, now available that can be used to telling effect in forecasting customer needs. This is important because for draught beers customers often run on very low stocks so that their working capital is reduced. The customer expects the supplier to deliver the beer immediately he requires it and in the appropriate state for dispense. In other words the customer wants the brewer to hold the stock. Good planning systems can turn this to advantage by using the principle of 'just in time' delivery so that brewery stock is also minimized. 'Just in time', must not become 'just too late'! If cask beer is being supplied then this is more difficult because of the finite time required for adequate secondary fermentation (Chapter 23).

Customer demand is the driving force behind most logistic systems. However, for national big brands (> 800,000 hl pa, approx. 500,000 imp. bbl) a system of 'vendor managed inventory' can be used. Here the supplier controls the stock in the supply chain and delivers to the customer depending on the supplier's view of the customer's requirements. This requires having software to monitor stock at the customer's premises and delivering when that stock requires replenishment. This means that the beer should be in the right place to meet demand and should guard against the customer who orders beer when, based on his sales, he does not really need it. Vendor managed inventory can thus prevent spurious shortages in the supply chain.

Delivery

Traditionally two types of delivery from breweries were recognized, primary and retail or radial. Radial delivery was very common in the UK where pubs were situated close to breweries and a retail fleet of vehicles would be based at the brewery and would make several trips to customers probably five or six days a week returning to the brewery each time with empty containers. This is still a major feature of regional breweries in Britain and the rest of the world.

Primary delivery constitutes delivery of beer from the brewery to a depot or regional distribution centre where stock is held. This is usually by heavy articulated vehicles with gross weights of up to 40 t. Draught beer is most often handled palletless, with groups of containers separated by plastic spacer boards. This reduces weight and allows a greater payload of beer.

As brewers have sought to differentiate their service to gain commercial advantage, the composite delivery has become common. In this system the brewer offers to deliver a composite mixture of beer in all package types and soft drinks and wine and spirits. This requires having the facility to do this at the brewery or depot. A retail or radial fleet must operate from the depot to the customer but frequently loads can be 'made-up' for the 'primary' vehicle and merely transferred to the retail vehicle and delivered to the customer.

A further complication is the delivery of beer by road tanker to a secondary location for further packaging. This might be beer for keggering or bottling or canning. In this situation the supplying and receiving departments must agree on the rules for delivery and acceptance to avoid the costly business of returning unemptied tankers to the source, which is to nobody's benefit. This is all the more relevant when the supplier and the receiver are part of the same company.

This whole business is about delighting the customer whilst operating at the lowest cost. Organization has been helped by seeking the registration of the business to quality standards such as ISO 9002. These systems do not, of course, result in improved quality to the customer's benefit *per se* but they do provide a written guide to a system of work that can be audited and subjected to continuous improvement. Another benefit of these systems resides in the fact that if they are not adhered to the registration can be removed by the auditing authority and that would be a considerable source of embarrassment to the brewer and could put him at severe disadvantage. There is, therefore, every incentive to maintain and improve the system.

22.3.2 Quality assurance

The second major aspect of modern distribution along with logistics is the assurance of quality. This is made much easier if the beer in the brewery is produced to sound standards. Customers rightly expect their beer to be delivered to the highest quality standards and, irrespective of any nationally approved quality management system, reserve the right to inspect the brewers' premises at any time. Quality is assured most effectively by the brewer having in place strict standards for the release of beer to delivery vehicles, whether for primary or retail supply. There should be a procedure in place the operation of which prevents sub-standard beer being delivered. This requires setting specifications for the beer in the warehouse and ensuring that the beer meets those specifications before it is delivered. This should avoid the requirement for recall of beer from the supply chain. No matter how good the system, however, some beer will be released which will not be of the right quality. It follows that product recall procedures must also be in place to assure the customer that the brewer is in charge of quality throughout the supply chain.

There will need to be some tolerance in the analytical values of the beer so as to prevent unnecessary hold-ups in supply. The system must also allow for 'beer on hold' whilst further analysis is carried out. A most important aspect of this release of beer to trade is the flavour of the beer. A properly trained panel, as part of the quality assurance beer release process, must taste all beers. Typical beer release parameters for a lager beer are shown (Table 22.1). Analyses will be determined on samples drawn from each brew.

Beer is likely to be released to primary delivery throughout the day. It is very important therefore that people on every shift in the warehouse or packaging department are trained in beer release procedures. They must have an understanding of the analytical values in Table 22.1. Of course, the beer should not be packaged if it does not meet the required specification. The required specification is often achieved by blending the contents of different bright beer tanks of the same beer quality. The accurate setting of the blend and the computation of the weighted average analysis are critical for success.

It is clear that quality assurance for distribution demands effective quality assurance throughout the supply chain in the brewery. This in turn demands effective communication from the brewhouse through to fermentation and to beer processing and packaging. Beer should not move along the supply chain unless it meets the in-

Table 22.1 Release parameters for a lager beer

Parameter	Target value	Permitted range
OG (°Saach)	40	38.5–41.5
PG (°Saach)	8	6.5–9.5
ABV (%)	4.1	3.9–4.3
pH	4.0	3.8–4.2
Colour (°EBC)	8.5	7.0–10.0
Bitterness (°EBU)	19	16.5–21.5
CO ₂ (vol.)	2.1	2.0–2.2
Dissolved oxygen in BBT (mg/l)	<0.1	0.1 max.
Flavour score (1–9)	>6	5 min.
Haze (°EBC, Monitek)	<0.3	0.3 max.
Diacetyl (mg/l)	<0.06	0.06 max.

ABV, alcohol by volume; BBT, bright beer tank

process specifications along the way. By doing this beer can be released with the minimum of delay and the customer gets his beer on time.

22.4 Summary

Throughout the world beer is now supplied to a wide variety of customers. Many of these are running businesses in which the sale of beer is not the major part. Their knowledge of the properties of beer may be scant or incomplete but their knowledge of their requirements for customer service is profound. This has developed from the demands of their customers, the beer consumer, and from the service they have enjoyed from other suppliers such as the suppliers of food and soft drinks. In this situation beer will not simply sell itself on the basis of inherent quality. The successful brewer therefore will heed the requirements of the customer in shaping his complete service. This will embrace the effective storage and distribution of the product to the delight of the customer. The successful brewer will utilize the principles of sound warehousing and the use of logistics to deploy stock most efficiently and utilize the vehicles. Finally, sound systems of quality assurance will be in place to protect against the delivery of sub-standard beer and avoid the need for product recall. Traditional customers who have sometimes tolerated less than excellent service as a result of their love of the product also benefit from the brewers' greater attention to good customer service.

22.5 References

- BLRA (1987–1995) *Statistical Handbooks*, Brewers' and Licensed Retailers' Association, London.
 BLRA (1999) *Beer and Pub Facts*, Brewers' and Licensed Retailers' Association, London.

Beer in the trade

23.1 Introduction

In recent years there have been large increases in the consumption of beer at home in bottles and cans (BLRA, 1999a). This has been particularly the case in Europe but has also occurred in North America. There has also been an increase in the consumption of beer in bottles in licensed premises. This has been associated with a greater emphasis on food being served along with beer. Frequently this beer is drunk directly from the bottle, which is usually of dark brown or green glass. In this situation the beer cannot be seen, which denies the drinker one of the pleasures of drinking beer, that of contemplating its appearance in the glass. Despite these trends the quality of draught beer drunk in the trade, i.e., in public houses and the like, is very important. Quality is influenced not only by the quality of the beer delivered but also by the conditions of storage in the public house and the conditions of the dispense of the beer. This applies equally to cask beer where a controlled secondary fermentation takes place in the container and to keg beer dispensed from a sterile container by gas top pressure.

Advertising of national and international beers centres on creating an 'image' of brand values which must be consistent. Brewers simply cannot leave the control of the quality of their beer to chance. They must ensure that good practice is applied in storage and at dispense, so that when the beer is drunk the intended quality is attained. This can be done by employing teams of people to advise customers on best practice and to ensure it is effected or to contract out this operation to a specialist company. Both systems are satisfactory. The owner of a strong brand can insist on the quality standards of storage and dispense being a prerequisite to allowing the customer to sell the product.

Beer is consumed in a wide variety of premises. These can vary from large city centre public houses and bars with extensive cellar facilities to beach bars where beer is served in ambient temperatures of over 30 °C (86 °F) with a simple on-line cooler. It follows that there must be some basic principles of management of beer in the trade if the brewer is going to satisfy the maximum number of customers in this variety of outlets.

23.2 History

Home brewing diversified into a craft industry to serve local communities. At this time all beer was dispensed on draught. Frequently the beer would be collected from the brewery in pots or jugs and then dispensed at home. Taxes also had an influence. In the UK there was a tax on glass in the 19th century, which was removed at the start of the 20th century, and this led to brewers examining the potential of bottling beer. In the UK the traditional container for beer was the cask, originally made from wood by coopers and now usually made of stainless steel or aluminium (Chapter 21). There is still a demand for cask beer but by 1998 this type of beer represented about 10% of total draught beer sales in the UK (BLRA, 1999b). In spite of intense interest in this type of beer by micro-brewers all over the world cask beer is much less significant in other countries and certainly so in the countries of largest production: USA, China and Germany. In these countries, and in most others, the most important type of draught beer is that dispensed from a pressurized container by gas top pressure in a stabilized and filtered form. This applies to both lager and ale.

The development of keg beer in the UK was stimulated by the presence of US airmen in the Second World War. Apparently they did not take to traditional British cask beer. This prompted development work by the brewer Greens of Luton who refined the process of putting sediment free, carbonated beer into metal containers and so keg beer was created (Bamforth, 1998).

23.3 Beer cellars

Traditionally beer was served from cellars. In the main this allowed for better temperature control and provided a space in which the beer containers could be organized and proper stock control carried out. For bars serving large volumes of beer in a week, say > 15 hl (9 imp. brl), an organized space is essential or it will be impossible to manage stock rotation and ensure that the beer is served on a 'first in first out' basis. The 'cellar' will not be below ground level in all bars but the principles of cellar design will still apply.

In most countries beer is classified as a foodstuff (Hunter, 1993) and so is subject to some food hygiene regulations. This means regular inspection by agents of local or national government. It follows that companies responsible for the management of the bar in which the beer is sold must have standards for the beer cellar which must be written down, continually assessed, and improved. This will be to the ultimate advantage of the customer and should be part of the way the brewer seeks to gain competitive advantage.

23.3.1 Hygiene

A beer cellar should be kept clean, and cleaning is greatly aided if the original design is sound. It is therefore surprising how infrequently very clean cellars are encountered. Floor surfaces should be hard, impervious, and smooth and should slope to a drain or sump. This makes regular hosing of the floor easy to manage. The sump should be cleaned weekly. Walls and the ceiling should have a smooth finish and can be tiled or treated with an anti-fungicidal paint. This allows for frequent washing and disinfection and the inhibition of mould growth. All equipment should be stored carefully and in a clean place away from the main area of beer dispense. Beer cellars should not be used for

storing other foodstuffs. Bacteria and wild yeast can be present on foods such as cheese and these can infect and will affect particularly cask beer.

23.3.2 Temperature

Temperature control in the brewery warehouse has been discussed (Chapter 22). Temperature control in the beer cellar is equally important if the beer is going to be at its best when served. Keg beer will almost certainly be passed through a beer cooler *en route* to the glass. Nevertheless, the workload of that cooler will be reduced if the temperature of the cellar is controlled. Beers will deteriorate more slowly in a cool cellar.

Cask beer requires more defined temperature control to allow effective secondary fermentation to take place and to prevent the development of flavour defects and to guard against possible infection as yeast activity subsides. The ideal cellar temperature to satisfy all these requirements is between 10 and 17°C (50 and 63°F). Temperatures were originally controlled by ventilation alone but now a cellar refrigeration unit is used. This should be fan assisted and must be properly sized for the cellar volume. Heat generating units of any sort (e.g. ice makers) should not be located in the cellar so as not to compete with the temperature control unit.

Ventilation of the cellar or storage area is important in its own right. Air, which is not changed, becomes stale, humid and musty and can promote the growth of moulds. There is also the safety hazard for the dispense of keg beers associated with the use of carbon dioxide and nitrogen. A rise in concentration of these gases can be fatal for persons working in cellars and they must be removed by ventilation and there must be training for staff to cover all aspects of the dangers of these gases.

23.3.3 Lighting

Cellars must be adequately lit and the level of lighting required is frequently laid down by statute. The best lighting is provided by fluorescent tubes with splash-proof covers (Hunter, 1993). In larger cellars emergency lighting is now often installed.

23.4 Beer dispense

Beers are judged visually as well as by flavour and aroma. How a beer appears in the trade is greatly influenced by how it is dispensed. This applies to both cask and keg beer and it is controlled by both the dispense equipment design and how it is used. This can be subject to historical regional influences. In the north of England drinkers generally prefer cask beer with a tight creamy head. In the south of England a loose open head is often preferred. As brewers seek to differentiate their products and gain competitive advantage greater emphasis has been placed on the quality of dispense. This is a key factor in defining the brand and major brands usually have unique dispense equipment and defined conditions of use.

Many of the widely differing beer selling premises are not owned by brewers, indeed, the beer may be supplied by a general wholesaler. Often staff serving beer are employed on a temporary basis or may not have received brewery training. It follows that the beer dispense equipment must be robust and tamper-proof if the brewer is to be satisfied with the presentation of his beer. It is also important that waste is minimized because fierce competition has led to a general reduction in the price the brewer obtains for his beer. In

turn this has led to a demand for a more robust cask beer that is easier to handle in the bar and less prone to wastage and dispense problems.

All recent developments in the dispense systems of keg and cask beers have sought to guarantee the quality in all kinds of places selling beer. However, there are aspects of the equipment that if neglected will lead to poor beer quality in the trade with a consequent loss of immediate sales and an adverse effect on the long-term market share of the brand.

23.4.1 Keg beer

Keg beers, ales or lagers, are packaged into sterile metal containers of size 25–100 hl, although in the UK barrels are still used (36 imp. gal or 163 hl). The beer has a defined content of carbon dioxide and will normally be dispensed by applying a top pressure of carbon dioxide gas or by using a mixed gas usually containing carbon dioxide and nitrogen. This is commonly called the ‘free-flow’ system. Pumps can also be used to assist the flow. A further refinement of the pumped system is to use a metered dispense where the beer is dispensed in pulses of a set volume, often 250 ml or, in the UK half an imperial pint (284 ml). Lagers are usually dispensed in a free-flow system with carbon dioxide alone whilst ales can be dispensed with carbon dioxide or with a carbon dioxide/nitrogen mixture. This presents the first challenge in assuring the quality of dispense.

Carbon dioxide

Every keg beer has a CO₂ specification. There must be careful adjustment of the pressure of CO₂ entering the keg to ensure perfect dispense of the product. The beer will be susceptible to picking up carbon dioxide or losing it. In either case dispense problems will follow and poor quality will result. If there is insufficient top pressure gas will break out of the beer into the head space of the keg and into the beer lines up to the dispense tap; a flat beer will result. If the top pressure is too high then more CO₂ will dissolve into the beer than is breaking out and the beer will over carbonate with consequent fobbing problems at the dispense tap.

Temperature is critical when using 100% carbon dioxide for dispense. If the temperature of the beer rises 1 °C (1.8 °F) then an additional 0.1 bar (1.47 lb./in.²) of pressure is needed. If the temperature falls by 1 °C then the pressure needs to be reduced by 0.1 bar. Temperature fluctuation is a common cause of beer dispense problems and one of the most frequent causes of complaints to the brewery. It is not a brewery problem provided that the carbon dioxide content of the beer was in specification on delivery. It is easy to eradicate in the trade by attention to the details of temperature control in the cellar.

Problems also occur with beer dispense in high ambient temperatures (Stanley, 1999). The temperature of the beer line to the tap is often at least 3 °C (5 °F) higher than the cool cabinet or cellar where the kegs are stored. Carbon dioxide will therefore break out of the beer in the dispense line and excessive fobbing at the tap will be the result. In this situation the CO₂ pressure should be set to be appropriate for the lower temperature. If the cool cabinet is at 2 °C (36 °F) and the beer line at 5 °C (41 °F) then the top pressure should be increased from 0.7 bar to 0.9 bar (10 to 13 lb./in.²). This would apply to a beer with, say, a CO₂ content of 2.6 vol/vol. A further complication is that over a period of a few days and as a consequence of the higher top pressure of the gas the carbonation in the beer will increase to about 2.9 vol/vol and fobbing at the tap will be the result. Pressure compensations are also required when forcing beer by top pressure along long runs of horizontal or vertical pipe. For every horizontal metre an additional 0.011 bar (0.16 lb./in.²) is required and for every vertical metre an extra 0.108 bar (1.59 lb./in.²).

Thus it is important to pay attention to the correct dispense pressures for the appropriate temperatures and lengths of installation pipe when using 100% carbon dioxide for dispense. It is highly desirable to maintain the beer at as constant a temperature as possible and to avoid major temperature differences between the beer in the store and the dispense lines to the tap.

Mixed gases

If the beer temperature cannot be held constant then dispense problems will always occur when using 100% carbon dioxide as the top pressure gas. A resolution to this problem is to introduce another gas to the headspace of the keg thus increasing the system pressure without the potential for increasing the carbon dioxide content of the beer. This can be done by using nitrogen and by using the correct blend of nitrogen and carbon dioxide. The partial pressure of the CO₂ is enough to maintain the required carbonation level of the beer. Nitrogen is not as soluble as CO₂ and will not affect the taste of the beer unless used at excessively high pressures. This system of mixed gas dispense can be used to dispense a variety of pale beers of delicate flavour in varying ambient conditions, without over carbonation. If the beer temperature cannot be controlled to better than $\pm 2^{\circ}\text{C}$ ($\pm 3.6^{\circ}\text{F}$) then a blend of 80% CO₂ and 20% nitrogen at 1.03 bar (15 lb./in.²) will eliminate dispense problems on a 2.6 vol/vol CO₂ beer.

A common system for using mixed gas is to use a blender to accurately proportion the gases from cylinders. These must be very carefully set and not tampered with. (The best systems will not operate when one of the gases has run out!) Pre-mixed gas can also be used, but this is often much more expensive than blending on site. The blends are sometimes not precise and are often low in carbon dioxide. They must therefore be checked with a gas analyser before use.

A different way of exploiting the use of mixed gas has been developed in the UK. Small amounts of nitrogen (10–50 mg/l) have a major positive effect on beer foam stability (Bishop *et al.*, 1975) and stability of draught stout is much improved by the inclusion of nitrogen in the beer. This principle has been extended to ale. This has largely been a market-led initiative to improve foam quality on keg ale and so provide a product similar in appearance to cask beer drawn by hand pulling. Nitrogen is added to filtered beer prior to packaging (Chapter 21) usually at rates of 15–40 mg/l. Normally this beer has a carbon dioxide content of around 1.1 vol/vol which is much lower than keg beers not containing nitrogen (up to 2.6 vol/vol).

Nitrogen-containing draught ales are dispensed with a mixed gas blend of carbon dioxide and nitrogen. The nitrogen now has the role of avoiding the loss of nitrogen in the beer during its dispense life as well as providing the motive force to drive the beer to the dispense tap without using excessively high levels of carbon dioxide (Lindsay *et al.*, 1996). Ale is not drunk in large volumes outside the UK and so this technique is of local interest. The introduction of nitrogen to lager beer has been tried but, because of the softening of the palate of the beer, has not always been commercially successful. Dispense problems with nitrogenated lager can be severe because of the much higher carbon dioxide level in the beer (2.6 vol/vol) which, if lowered, produces an insipid mouth-feel.

Beer pumps

Beer pumps can also be used to protect against the effects of temperature changes between the beer store and the dispense tap. Mechanical pressure is used to push the beer to the tap rather than the gas top pressure on the keg. This avoids the use of any gas other

than carbon dioxide. Pressure on the keg can be set at 0.8 bar (12 lb./in.²) and can be easily increased to 1.4 bar (20 lb./in.²) in the beer line by a pump. Systems using pumps require more maintenance, and hence are more costly to operate than systems relying on gas pressure alone. A development of the pump particularly used in the UK was the positive displacement meter. Beer was dispensed at high speed, in fixed pulses usually of one half imperial pint (284 ml). These systems are not being widely used. They are expensive to maintain. Further, in countries where the head on the beer is ruled as being part of the beer measure then the meter is difficult to operate to customer satisfaction. The properly balanced mixed gas system offers the most flexible solution to providing excellence in dispense at lowest cost without the danger of over carbonation.

Beer lines

A beer line is the route of supply from the storage container in the cellar to the dispense tap on the bar. The line itself is usually made of polythene or PVC tubing of appropriate diameter. Poor design of the beer line or poor cleaning will adversely affect quality of the dispensed beer. The system should be designed and adjusted to give a flow rate of about 12.5 sec for 500 ml (14 sec/imp. pint) of beer (Heron, 1992). This demands balancing the top pressure used against the restriction provided by the line. Although this time period is a good 'rule of thumb' competitive advantage is sometimes sought by brewers by deviating widely from this norm. This particularly applies to nitrogenated ales where longer dispense times are demanded to heighten anticipation of the drink.

Long beer lines (> 30 m; 98 ft.) should be cleaned using an installed system involving re-circulation of the cleaning fluid. Acid based cleaners should be used frequently to avoid the accumulation of beer stone. Transparent pipe is best so that accumulation of soil can be seen easily and gas 'break out' observed. There have been recent improvements to line cooling systems. Originally line cooler units were situated below the bar. Cooling used a chilled water bath with the beer passing through in coils of tubing immersed in the chilled water. Further developments used ice-bank coolers with the beer subject to rapid cooling by ice to supply outlets with high demand. Modern units have beer re-circulation pumps to allow variable temperature control on ales and lagers.

A major development has been the use of remote coolers, which have the advantage of removing the heat source from below the bar. They are usually situated immediately outside the cooled beer cellar. Beer is supplied to the bar through an insulated pipe containing cooling water known as a 'python'. Large systems can accommodate up to 16 separate routes for beer, known as product coils (Fig. 23.1). The primary lager python can be held at a lower temperature than the secondary ale python, which can take re-circulation water from the lager line to save energy (Fig. 23.2). Pythons are now sometimes used with under-counter cooling modules, which can further trim beer temperature, and they will take chilled water from the python.

Manufacturers of keg beer dispense systems usually provide advice on the operation and cleaning of their equipment. Follow that advice! Many problems of beer quality encountered in bars are simply a result of poor cleaning or of operating systems at the wrong pressures or with poor temperature control.

23.4.2 Cask beer

The cask beer market in the UK still amounts to the considerable annual volume of about 6 million hl (3.7 m imp. brl). Cask beer requires very different treatment in the trade from keg beer. The major factor affecting cask beer dispense is that cask beer contains live

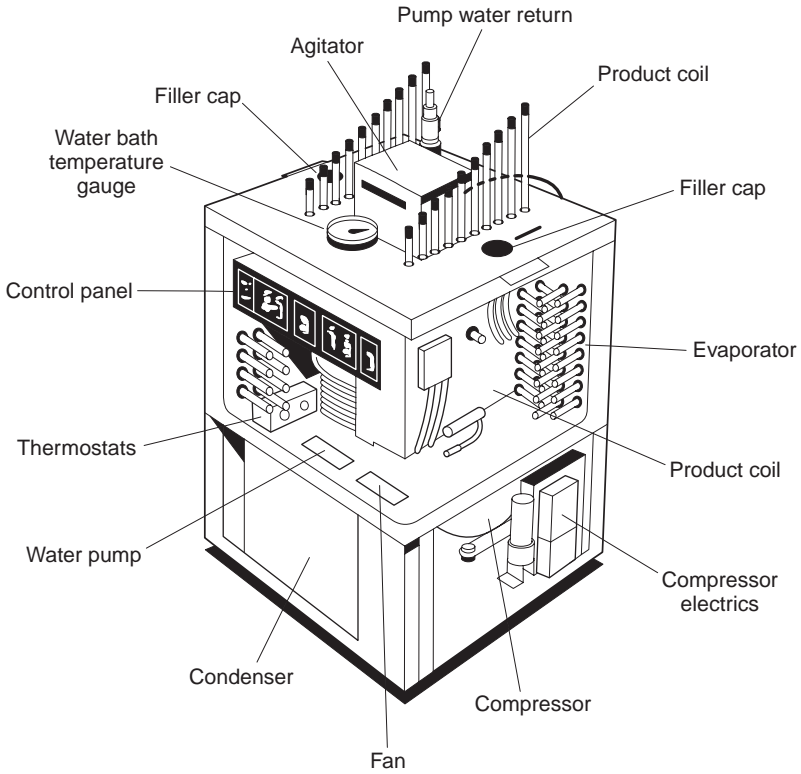

Fig 23.1 Large remote beer dispense cooler (Lindsay, 2002).

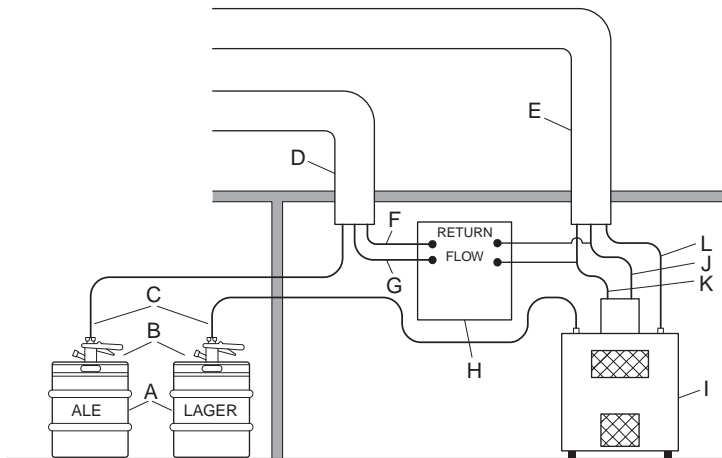

Fig 23.2 Secondary keg ale python installed with a remote beer cooler and lager python. A, kegs; B, keg connector; C, PVC or polythene tubing; D, ale python; E, lager python; F, ale python water re-circulation line (return); G, ale python water re-circulation line (flow); H, python driver; I, remote cooler; J, lager python water re-circulation line (return); K, lager python water re-circulation line (flow); L, lager product line. The ale python takes re-circulation water from the lager line (Lindsay, 2002).

yeast to effect the secondary fermentation to give condition to the beer. Cask beer, therefore, has a shelf-life of only 3–4 weeks and everything must be geared to ensuring that the beer is drunk in perfect condition within this time period.

Delivery of beer

An important point is to check that the beer being delivered is within the age profile laid down by the brewery so that, given time to settle, it will be dispensed within the shelf-life. This requires knowledge of the throughput of the bar. Containers should not be leaking and the shives and keystones (Chapter 21) should be intact and clean. The casks should be located by the draymen in the position where they are to be dispensed. The more they are moved the less satisfactory will be the fining action on which beer clarification depends.

Stillaging

Casks should be positioned on the level on the stillage (a wooden or metal frame on which the casks are raised off the floor of the cellar) with the shive uppermost and the keystone centrally located at the bottom. The casks should then be secured with wooden wedges (scotches). The sediment will now collect in the belly of the cask. Sometimes a tilting stillage is used where the cask can be progressively tilted forward as the beer is dispensed. This has to be done with care or the sediment will block the dispense tap.

An alternative system is to stillage vertically with the keystone uppermost (Hunter, 1993). The beer is subsequently dispensed through a hollow rod and so the cask must be tilted by positioning a wedge directly under the location of the keystone. The sediment then collects away from the rod inlet. Purists would argue this is not genuine cask beer!

Pegging (spiling)

The secondary fermentation in the cask produces carbon dioxide, which causes a rise in pressure in the container. This pressure should be released gently or the sediment in the cask can be excessively disturbed when the cask is tapped for dispense.

The shive should first be scrubbed clean and then a soft porous peg is driven carefully into the depression in the shive (tut). This will allow the beer to ‘work’ gently as the carbon dioxide escapes through the porous peg. This operation should be carried out between three and six hours from delivery. The soft pegs should normally be changed twice a day. The beer may continue to give off gas for 12–24 hours. When this working has stopped the soft peg should be removed and replaced with a non-porous, hard peg. The hard pegs should be eased daily to prevent further pressure build up. Best practice demands the insertion of a soft peg whilst the beer is being dispensed as this acts as an air filter. Between dispense sessions a hard peg should be inserted to maintain beer condition.

Tapping

The keystone must first be scrubbed clean and then a clean tap should be smartly driven into the already pegged cask with a single hammer blow. A tap should never be inserted into an un-pegged cask. The beer should be tapped about 12–24 hours before it is required for sale. This can, of course, vary but most cask beers will have dropped bright (yeast and sediment will have settled) and have stopped working in 12–48 hours from delivery although on occasions 72 hours may be needed. Before connection to the dispense line about 250 ml ($\approx \frac{1}{2}$ imp. pint) of beer should be drawn off through the tap to clear any sediment around the tap. This beer should be discarded. A further 250 ml ($\approx \frac{1}{2}$ imp. pint) should then be drawn and checked for clarity, aroma, and taste. If the beer is found to be true to type the container can be connected to the dispense line so the beer can be sold.

Tilting

Stillaged casks should be tilted forward when about one-third of the contents of the cask have been sold and not before. A fall of about 7 cm (2.75 in.) is needed. This allows the maximum yield of beer from the cask. The task should be done carefully so as not to disturb sediment.

Dispense

Originally beer was dispensed into a jug through the tap from the stillaged cask at the back of the bar. In Victorian times the casks were placed in a cellar but the beer was still drawn from taps into jugs and brought up to the bar by 'pot-boys'. The hand pulled pump, the beer engine, was developed in the early 20th century so that beer could be pumped up from the cellar to the bar. Beer engines were originally made of brass but are now almost always made of stainless steel or plastic to avoid any possibility of lead dissolving into the beer (Fig. 23.3). The size of the cylinder is usually a quarter or a half imperial pint (150 or 300 ml). The tap on the cask is connected to the cylinder by tubing which is usually a clear plastic (often PVC) and in this way yeast build up is easily seen.

Typically, cask beers were dispensed at 10–15 °C (50–59 °F) and this was achieved by controlling cellar temperature. There has recently been a demand to drink cask beer at lower temperatures sometimes down to 7 °C (45 °F). Whether this is a result of consumer demand or has been led by marketing departments seeking to promote keg beer is uncertain! This has led to cooling cask beer *en route* from cask to bar. Using a water-cooled cylinder in the beer engine, which usually means it will have the smaller volume of a quarter pint, can do this. Sometimes cask beer pythons are used (Fig. 23.4) in outlets serving a range of cask beers. There have been systems for introducing a gas mixture of carbon dioxide and nitrogen into the cask beer before dispense to increase the evenness of the foam and decrease bubble size (Watts, 2000). This is moving cask beer towards keg beer in sensory experience and would not find favour with beer traditionalists.

The spout from the beer engine that delivers beer to the glass can be of various designs. It usually ends in a plastic removable tip, the sparkler, which can have a varying number of holes. Thus beer can be delivered through a 'swan-neck' or straight spout to a tight or slack sparkler or even to no sparkler! This has a profound effect on the physical state of the beer in the glass, which can have a tight creamy head with much foam cling, or a slack open head with little foam cling as the beer is drunk. The variations are almost endless and are subject to much regional influence in the UK and much debate wherever cask beer drinkers meet.

Hygiene

Cleanliness is absolutely essential when dealing with cask beer. All the implements used must be scrupulously clean. Shives, pegs and keystones should be kept in a sealed container to avoid the pick-up of airborne moulds. There should be a permanent wall mounting for mallet, dipstick, taps and brushes. Cask beer delivery pipes must be cleaned at least weekly. They should be flushed with cold water and filled with detergent to the recommended concentration; an effective system would use 1% sodium hypochlorite solution. Soaking should be for 10–15 minutes and then a further 10–15 minutes with a fresh batch of detergent (Heron, 1992) this ensures all deposited and suspended materials are removed. Finally there must be a thorough rinse with cold water.

Clean glasses are important. This applies equally to beer dispensed from kegs. Most bars use a glass washing machine and this must be correctly used and maintained. It must

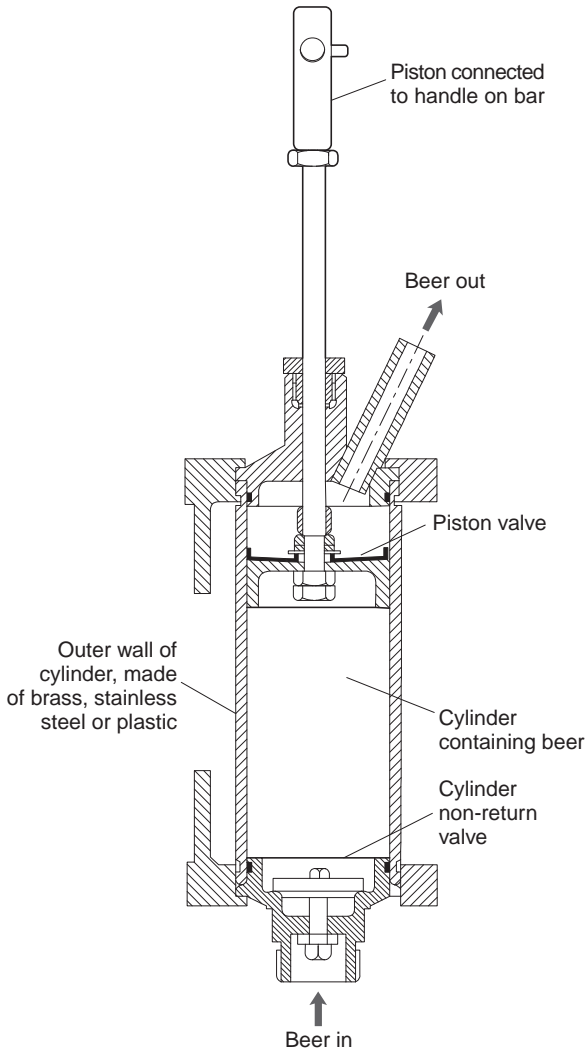

Fig 23.3 Beer engine cylinder. This operates as a simple lift pump. When the handle on the bar is pulled down the piston rises. The non-return valve at the beer inlet opens. Beer is drawn in beneath the piston. The piston valve remains closed. The handle is then returned to the upright position. The cylinder valve now closes and the piston valve opens. The piston passes through the beer in the cylinder and the beer is lifted out of the cylinder to the bar counter and dispensed. This is often through a 'swan-neck' device (see Fig. 23.4). The process is repeated several times to deliver a full glass of beer at the bar.

have adequate water pressure and flow rate and the detergent temperature must be accurately controlled. Replacement of the salt must be carried out according to the number of washing cycles actually used not simply on a weekly basis. Washed glasses must be left on a clean, odourless surface to cool completely before use. Glasses should be inspected by a competent member of the bar staff to ensure they are absolutely clean and free of taint.

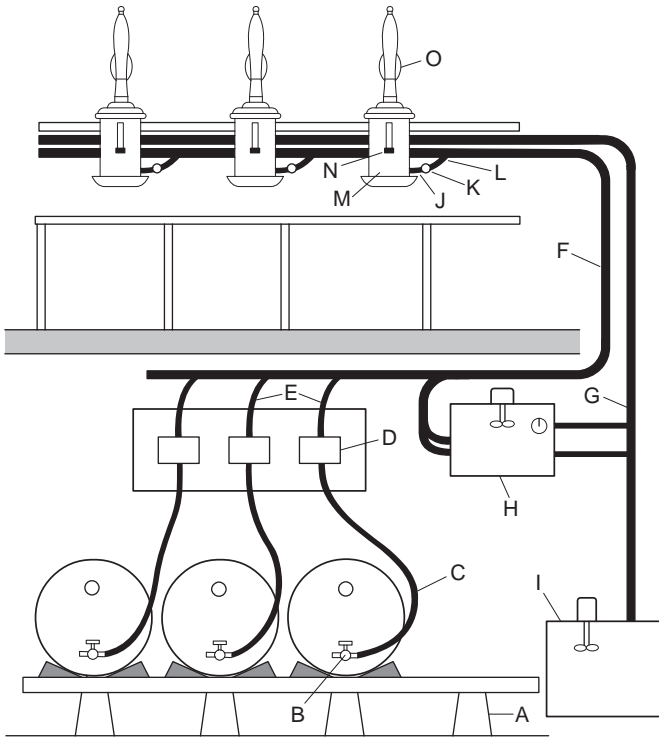

Fig 23.4 Cask ale python to allow dispense of cask beer to temperatures $\leq 7^{\circ}\text{C}$, often used in outlets serving a range of cask beers in low volume. A, stillage; B, cask tap; C, clear PVC tubing (0.375 in., 10 mm, internal diameter); D, pump; E, polythene tubing (0.375 in., 10 mm, external diameter); F, ale python; G, lager (main python); H, ale python driver; I, remote cooler; J, polythene tubing (0.375 in., 10 mm internal diameter); K, check valve; L, polythene tubing (0.375 in., 10 mm external diameter); M, $\frac{1}{4}$ pint hand-pull with swan neck spout; N, agitator (sparkler) to suit product on dispense; O, pump clip for product on dispense (Lindsay, 2002).

Empty casks

Empty casks should be removed immediately from the stillage. The tap should be removed and thoroughly washed. A hard peg should be driven into the shive and a cork should be driven into the keystone hole. The cask should then be put in a suitable place for collection by the drayman.

Throughput

The final factor affecting the quality of cask beer is the throughput of the product. This is much more critical than for the chilled and filtered keg beer. The minimum throughput of any one quality should be two containers per week (Hunter, 1993) of whatever size is appropriate to the outlet. A cask beer container when broached should be sold in not more than 72 hours and preferably within 48 hours. The frequent cause of poor cask beer quality is the failure to observe these guidelines.

There is a trend in the UK to offer customers a very wide choice of cask beers in 'real ale houses'. This has often resulted in the flouting of the throughput guidelines, with the result poor beer has been put on sale. This is not good for the image of cask beer and is a reason for the increase in sales of the nitrogenated keg ales (Section 23.4.1). There is also the trend to serve the cask beer at lower temperatures in an attempt to extend its shelf-life.

These attempts are not always successful and the true flavour of the beer often suffers. At the present time the trend to keg beer continues and it seems likely that cask beer sales in the UK will continue to fall.

23.4.3 Bottled and canned beer

Drinking beer from bottles and cans is associated with drinking beer at home. Indeed in the UK off-trade sales of beer have risen from 10% of the total to over 30% of the total in the last 30 years (BLRA, 1999b). On-trade sales of small-pack beer were traditionally in returnable bottles but as a result of the influence of the package types sold in supermarkets, non-returnable bottles and even cans are now sold in the on-trade. Total sales of beer in cans in the UK have increased from 5% in 1974 to 25% in 2000 and in non-returnable bottles from < 1% in 1974 to 12% in 2000. Much of this beer is now drunk in pubs.

International beer brands are frequently sold in several package types, usually in bottles, cans and kegs. To preserve the identity and integrity of the brand it is essential that the quality is maintained in all package types. In the trade, therefore, it is important that beer served from a bottle or can is served correctly. This is not, of course, as difficult as with keg or cask beer. The main requirement is to serve clean bottles and to make sure the bottles are displayed attractively with the labels visible to the public. Almost always the bottle contents will be served cold, in some countries as low as 3 °C (37 °F). The bottles will be stored cold behind the bar in a refrigerator or in a cooled cabinet with clear glass doors.

The pleasure of drinking some beers is enhanced by the use of branded glasses. However, there is a marked trend amongst young drinkers to drink from bottles when some of the pleasures of drinking beer are lost.

23.5 Quality control

Most brewing companies operate to the principles of quality assurance so that sound and in-specification beer is delivered to their customers. The control of quality in the trade depends on the strict observance of all the principles of storage and dispense of beer discussed in this chapter. If these principles are followed then the customer should receive a perfect beer to drink.

Many brewing companies employ inspectors to investigate premises where their beer is consumed. The focus is on the condition of the beer cellar, the storage of the beer and on the condition of the beer dispense systems. Throughout the world these inspection systems have come under pressure as brewers have sought to save costs and less trade quality control work is now carried out. This is dangerous for the competitive position of beer related to other drinks.

23.6 New developments in trade quality

Conventional beer analyses do not always indicate how the beer will perform in the trade under the variety of conditions now prevalent (Watts, 2000). Foam quality and head retention on a beer, for example, has always been an important attribute. Head retention has been measured by a number of techniques amongst the most robust of which is the

Rudin method (Rudin, 1958), which measures foam collapse under standard and reproducible conditions. Recent studies have revealed beers with very similar Rudin values and yet having markedly different foam stabilities (Watts, 2000). This could represent problems for a brewer. Foam stability is defined as the depth of foam remaining on a beer after a two-minute interval following a standard pour (Watts, 2000). A 'visual assessment profile' has been developed to complement traditional beer analysis and so provide a more complete picture of the behaviour of the beer under trade conditions.

Beers are assessed both quantitatively and qualitatively for foam quality, lacing, clarity, colour, 'reflux' and 'seeding' (see also Chapters 19 and 20). Reflux is a combination of the wave-like surge motion and overall bubble settling time on a draught dispensed beer. Seeding refers to the bubbles that rise up in the body of the beer. A trained panel of assessors examines each beer five times after a standard pour. This technique has been used to assess the effect of dispense head nozzle design on reflux. It was demonstrated that on a nitro-keg beer a nozzle pore size of 0.6 mm (0.024 in.) gave a significant increase in reflux compared to nozzle sizes of 0.7 mm (0.027 in.) and 0.8 mm (0.031 in.). This was ascribed to the greater shear when the beer was forced through the smaller nozzle. This provides considerable scope for changing the physical character of the beer where it is dispensed.

Another factor of recent significance is the use of toughened glasses. There is considerably less seeding in lager beers poured into toughened glasses (Watts, 2000). This is presumably a result of the smoother surface not providing nucleation points for bubble formation.

23.7 Summary

Beer is drunk in a wide variety of premises, where the consumer forms his opinion of the beer. If the opinion is favourable then it is likely that the consumer will return and drink the beer again, as the brewer desires – he seeks the delighted consumer. The brewer starts this process by assuring the highest quality of his beer to his customer, the vendor. It is then essential to ensure that the beer is stored and dispensed according to good practice at the premises where it is sold. This means scrupulous attention to the procedures of dispense for keg and cask beer, and detailed attention to hygiene of the cellar, dispense equipment and the glass.

23.8 References

- BAMFORTH, C. W. (1998) *Tap into the Art and Science of Brewing*, New York, Insight Books.
 BLRA (1999a) *Beer and Pub Facts*, Brewers' and Licensed Retailers' Association, London.
 BLRA (1999b) *Statistical Handbook*, Brewers' and Licensed Retailers' Association, London.
 BISHOP, L. R., WHITEAR, A. L. and INMAN, W. R. (1975) *J. Inst. Brewing*, **81**, 131.
 HERON, P. C. (1992) *Brewers' Guard*, **121** (9), 29.
 HUNTER, A. R. (1993) *The Brewer*, **79**, 159.
 LINDSAY, R. F. (2002) Personal communication.
 LINDSAY, R. F., LARSSON, E. and SMITH, I. B. (1996) *Tech. Quart. MBAA*, **33**, 181.
 RUDIN, A. D. (1958) *J. Inst. Brewing*, **64**, 238.
 STANLEY, J. M. (1999) *Tech. Quart. MBAA*, **36**, 293.
 WATTS, E. (2000) *Brewers' Guard*, **129** (2), 20.

Appendix: units and some data of use in brewing

Table A1 SI derived units	833
Table A2 Prefixes for SI units	834
Table A3 Comparison of thermometer scales	835
Table A4 Interconversion factors for units of measurement	837
Table A5 Specific gravity and extract table	838
Table A6 Equivalence between Institute of Brewing units of hot water extract	841
Table A7 Solution divisors of some sugars	842
Table A8 Some properties of water	842
Table A9 The density and viscosity of water at various temperatures	842
Table A10 Some properties of water	843
Table A11 The relationship between pressure and the temperature of steam	843
Table A12 The solubility of pure gases in water at different temperatures	844
Table A13 Salts in brewing liquors	844
Table A14 Units of degrees of water hardness	845
Table A15 Characteristics of some brewing materials	845
Table A16 Pasteurization units (PUs)	846
Fig. A1 The relationship between ethanol/water mixtures and the densities of the solutions.	847

Introduction

Although there is a gradual trend towards the use of metric, or the derived SI units of measurement, their use is not universal and, of course, they were used less in the past. The nightmare muddle into which older British unit ‘systems’ had degenerated is noted elsewhere, particularly as they relate to cereal grains and malt (Briggs, D. E. (1998) *Malts and Malting*, p. 742, London, Blackie Academic and Professional, or Aspen Publishers, Gaithersberg). American units, while having the same names as British units, often differ significantly in size. Thus, while the American gallon (gal. US) contains only 8 pounds (lb.) of water or 8 pints each weighing 1 lb., the British gallon (gal. UK, or imp. gal.)

contains 10 lb., and so the British pint contains 1.25 lb. of water. To have access to older and modern technical literature it is imperative that all units be understood and that readers have the information to allow them to convert reported values into units they are familiar with. In this book, wherever practical, metric or SI units have been used but equivalents in other units are given where this may be helpful even though this may be irritating to some readers, as it is to the authors.

This appendix contains values for derived SI units and prefixes for them (Tables A1 and A2), equivalents for thermometer scales ($^{\circ}\text{C}$, $^{\circ}\text{F}$ and $^{\circ}\text{R}$; Table A3) and interconversion factors for metric, British (imp. or UK) and American (US) units (Table A4). Table A5 gives the relationships between SG and extract values, while Table A6 gives the approximate equivalents between hot water extracts as determined by the older and the modern methods of the Institute and Guild of Brewing. Table A7 gives some solution divisors for sugars. Various properties of water are given in Tables A8, A9 and A10, including the pK_w values and the amounts of oxygen dissolved from air or oxygen at different temperatures, the specific heats, latent heats, and surface tension at several temperatures. The relationship between steam pressure and temperature is summarized in Table A11. Table A12 gives the solubility of oxygen, nitrogen and carbon dioxide in water at different temperatures. Tables A13 and A14 give some data regarding salts in brewing liquors and units of water hardness. Table A15 contains information on the storage characteristics of some grist materials. Table A16 gives data on beer treatment temperatures and pasteurization units (PUs). Figure A.1 shows the relationship between the composition of ethanol/pure water, mixtures and their densities.

As explained in the text, there are cases where there are no valid interconversion factors between analytical values. Thus the laboratory meshes specified in the *Recommended Methods of the Institute and Guild of Brewing* and *Analytica-EBC* (Section 1.15.1, p. 9) are different and can yield different extract recoveries and yields of soluble nitrogen. In consequence there are no valid factors for interconverting HWE and E, or the SNR and the Kolbach Index.

Table A1 SI derived units. The base units are shown below

Physical quantity	Name	Symbol	Definition
Energy	joule	J	$\text{kg m}^2/\text{s}^2$
Force	newton	N	$\text{kg m}/\text{s}^2 = \text{J}/\text{m}$
Power	watt	W	$\text{kg m}^2/\text{s}^3 = \text{J}/\text{s}$
Electrical charge	coulomb	C	A s
Electrical potential difference	volt	V	$\text{kg m}^2/\text{s}^3$ per $\text{A} = \text{J}/\text{A}$ per s
Electrical resistance	ohm	Ω	$\text{kg m}^2/\text{s}^3$ per $\text{A}^2 = \text{V}/\text{A}$
Inductance	henry	H	$\text{kg m}^2/\text{s}^2$ per $\text{A} = \text{V}/\text{A}$ per s
Luminous flux	lumen	lm	cd sr
Illumination	lux	lx	$\text{cd sr}/\text{m}^2$
Frequency	hertz	Hz	per s
Pressure	pascal	Pa	N/m^2

Where m is the metre; kg is the kilogram; s is the second; A is the ampere; cd is the candela (luminous intensity); sr is the steradian (solid angle).

Other base units are: Kelvin (K), thermodynamic temperature and temperature interval; mole (mol) molecular (or atomic) mass.

Table A2 Prefixes for SI units

Fraction	Prefix	Symbol
10^{-15}	femto	f
10^{-12}	pico	p
10^{-9}	nano	n
10^{-6}	micro	μ
10^{-3}	milli	m
10^{-2}	centi	c
10^{-1}	deci	d
10^1	deka	da
10^2	hecto	h
10^3	kilo	k
10^6	mega	M
10^9	giga	G
10^{12}	tera	T

Table A3 Comparison of thermometers showing the relative indications of the Fahrenheit, centigrade and Réaumur scales*

Scale	Boiling point	Freezing point
Fahrenheit (°F)	212	32
Centigrade (°C)	100	0
Réaumur (°R)*	80	0

Conversion of thermometer degrees

1°C = 1.8°F = 0.8°R. °C to °R, multiply by 4 and divide by 5. °C to °F, multiply by 9, divide by 5, then add 32. °R to °C, multiply by 5 and divide by 4. °R to °F, multiply by 9, divide by 4, then add 32. °F to °R, first subtract 32, then multiply by 4, and divide by 9. °F to °C, first subtract 32, then multiply by 5, and divide by 9.

°F	°C	°R	°F	°C	°R
302	150	120	159.8	71	56.8
284	140	112	158	70	56
266	130	104	156.2	69	55.2
257	125	100	154.4	68	54.4
248	120	96	152.6	67	53.6
239	115	92	150.8	66	52.8
230	110	88	149	65	52
221	105	84	147.2	64	51.2
212	100	80	145.4	63	50.4
210.2	99	79.2	143.6	62	49.6
208.4	98	78.4	141.8	61	48.8
206.6	97	77.6	140	60	48
204.8	96	76.8	138.2	59	47.2
203	95	76	136.4	58	46.4
201.2	94	75.2	134.6	57	45.6
199.4	93	74.4	132.8	56	44.8
197.6	92	73.6	131	55	44
195.8	91	72.8	129.2	54	43.2
194	90	72	127.4	53	42.4
192.2	89	71.2	125.6	52	41.6
190.4	88	70.4	123.8	51	40.8
188.6	87	69.6	122	50	40
186.8	86	68.8	120.2	49	39.2
185	85	68	118.4	48	38.4
183.2	84	67.2	116.6	47	37.6
181.4	83	66.4	114.8	46	36.8
179.6	82	65.6	113	45	36
177.8	81	64.8	111.2	44	35.2
176	80	64	109.4	43	34.4
174.2	79	63.2	107.6	42	33.6
172.4	78	62.4	105.8	41	32.8
170.6	77	61.6	104	40	32
168.8	76	60.8	102.2	39	31.2
167	75	60	100.4	38	30.4
165.2	74	59.2	98.6	37	29.6
163.4	73	58.4	96.8	36	28.8
161.6	72	57.6	95	35	28

Table A3 continued

°F	°C	°R	°F	°C	°R
93.2	34	27.2	57.2	14	11.2
91.4	33	26.4	55.4	13	10.4
89.6	32	25.6	53.6	12	9.6
87.8	31	24.8	51.8	11	8.8
86	30	24	50	10	8
84.2	29	23.2	48.2	9	7.2
82.4	28	22.4	46.4	8	6.4
80.6	27	21.6	44.6	7	5.6
78.8	26	20.8	42.8	6	4.8
77	25	20	41	5	4
75.2	24	19.2	39.2	4	3.2
73.4	23	18.4	37.4	3	2.4
71.6	22	17.6	35.6	2	1.6
69.8	21	16.8	33.8	1	0.8
68	20	16	32	0	0
66.2	19	15.2	30.2	-1	-0.8
64.4	18	14.4	28.4	-2	-1.6
62.6	17	13.6	23	-5	-4
60.8	16	12.8	14	-10	-8
59	15	12	-4	-20	-16

* In this table °R is the Réaumur (not the Rankine) scale.

Table A4 Interconversion factors for units of measurement

$m = 1.0936 \text{ yard} = 3.280 \text{ ft.}; \text{ cm} = 0.39370 \text{ in.};$
 $\text{hectare} = 2.471 \text{ acre}; m^2 = 10.764 \text{ ft.}^2; \text{ cm}^2 = 0.1550 \text{ in.}^2;$
 $m^3 = 1000 \text{ dm}^3 \text{ (or litre)} = 33.315 \text{ ft.}^3 = 61024 \text{ in.}^3 = 1.30795 \text{ yd.}^3;$
 $\text{hl} = 100 \text{ dm}^3 \text{ (or litre)} = 21.998 \text{ gal. (British)} = 26.418 \text{ (US)} = 0.6111 \text{ barrel (British)} = 0.8387$
 $\text{barrel (US)} = 0.8522 \text{ beer barrel (US)} = 0.1 \text{ m}^3$
 $l = 35.196 \text{ fl. oz. (British)} = 33.815 \text{ fl. oz. (US)} = 0.21998 \text{ gal. (British)} = 0.26418 \text{ gal. (US)} =$
 0.035315 ft.^3
 $\text{tonne} = 1000 \text{ kg} = \text{short ton} = 0.984207 \text{ long ton} = 2204.62 \text{ lb.} = 10 \text{ doppelzentner} = 20 \text{ zentner};$
 $\text{zentner} = 50 \text{ kg} = 0.984 \text{ cwt} = 110,321 \text{ lb.}; 1 \text{ kg} = 2.20462 \text{ lb.}$
 $g = 0.03527 \text{ oz.} = 15.432 \text{ grain}; \text{ kg/m}^3 = \text{g/dm}^3 = 0.062428 \text{ lb./ft.}^3$

British measures

$\text{yard} = 3 \text{ ft.} = 36 \text{ in.} = 0.9144 \text{ m}; \text{ ft.} = 0.3048 \text{ m}; \text{ lb./ft.}^2 = 4.88243 \text{ kg/m}^2$
 $\text{in.} = 2.540 \text{ cm} = 1000 \text{ thou (thousandth of an inch)}; \text{ lb./ft.}^3 = 16.0185 \text{ kg/m}^3$
 $\text{thou} = 25.4 \text{ micron or micrometer } (\mu\text{m});$
 $\text{acre} = 4840 \text{ yd.}^2 = 0.4047 \text{ hectare (ha)};$
 $\text{yd.}^2 = 0.8361 \text{ m}^2; \text{ ft.}^2 = 9.290 \text{ dm}^2; \text{ in.}^2 = 6.4516 \text{ cm}^2;$
 $\text{yd.}^3 = 0.7646 \text{ m}^3; \text{ ft.}^3 = 28.317 \text{ dm}^3; \text{ in.}^3 = 16.3871 \text{ cm}^3;$
 $\text{ton (long)} = 20 \text{ cwt} = 2240 \text{ lb.} = 1016 \text{ kg} = 1.01605 \text{ tonne (short ton; metric)};$
 $\text{lb.} = 16 \text{ oz.} = 256 \text{ dram} = 7000 \text{ grains} = 0.45359 \text{ kg};$
 $\text{oz.} = 28.35 \text{ g}; \text{ grain} = 64.80 \text{ mg};$
 $\text{gal.} = 160 \text{ fl. oz.} = 8 \text{ pints} = 1.201 \text{ gal. (US)} = 4.546 \text{ litre} = 0.1605 \text{ ft.}^3 = 0.125 \text{ bu (British)};$
 $\text{pint} = 0.5682 \text{ litre}; \text{ fl. oz.} = 28.412 \text{ ml};$
 $\text{butt} = 2 \text{ hogshead} = 3 \text{ barrel} = 108 \text{ gal.} = 4.9096 \text{ hl};$
 $\text{brl} = 2 \text{ kilderkin} = 4 \text{ firkin} = 36 \text{ gal.} = 1.6365 \text{ hl} = 1.4 \text{ brl beer (US)} = 4.5 \text{ bu (British)};$
 $\text{bushel (bu, British)} = 8 \text{ gal. (UK)} = 36.3687 \text{ dm}^3 = 0.9690 \text{ bu (US)}; 8 \text{ bu} = 1 \text{ Qr.}$
 $100\% \text{ proof spirit (British)} = 57.10\% \text{ ethyl alcohol (v/v)} = 49.28\% \text{ ethyl alcohol (m/m), relative}$
 $\text{density } 0.91976 \text{ at } 60^\circ\text{F.}$

US measures

$\text{beer brl} = 31 \text{ gal. (US)} = 25.81 \text{ gal. (British)} = 1.734 \text{ hl} = 0.717 \text{ brl British};$
 $\text{standard brl} = 31.5 \text{ gal. (US)} = 26.23 \text{ gal. (British)} = 1.1924 \text{ hl} = 0.729 \text{ brl (British)};$
 $\text{gal} = 8 \text{ pint} = 128 \text{ fl. oz.} = 3.7853 \text{ litre} = 0.8327 \text{ gal. (British)} = 231.0 \text{ in.}^3$
 $\text{bushel (bu, US)} = 35.23907 \text{ litre} = 1.03203 \text{ bu (British).}$

Barley and malt measures

Britain and South Africa: $\text{barley bushel} = 56 \text{ lb.} = 75.401 \text{ kg};$
 $\text{barley quarter} = 448 \text{ lb.} = 4 \text{ cwt} = 0.2 \text{ ton} = 203.209 \text{ kg};$
 $\text{malt bushel} = 42 \text{ lb.} = 19.051 \text{ kg};$
 $\text{malt quarter} = 336 \text{ lb.} = 3 \text{ cwt} = 0.15 \text{ ton} = 152.407 \text{ kg}$
 Australia and New Zealand: $\text{barley bushel} = 50 \text{ lb.}; \text{ malt bushel} = 40 \text{ lb.}$
 US and Canada: $\text{barley bushel} = 48 \text{ lb.}; \text{ malt bushel} = 34 \text{ lb.}$

Useful data (some equivalents are approximate)

$\text{kcal} = 4.186 \text{ kJ} = 3.968 \text{ btu (BTU)} = 1.1628 \text{ Wh} = 3088 \text{ ft. lb.}$
 $\text{btu} = 1.055 \text{ kJ} = 0.252 \text{ kcal} = 0.2931 \text{ Wh} = 778.2 \text{ ft. lb.}$
 $\text{Wh} = 3.6 \text{ kJ} = 0.860 \text{ kcal} = 3.412 \text{ btu} = 2655 \text{ ft. lb.}$
 $\text{therm} = 105.506 \text{ MJ} = 29.307 \text{ kWh};$
 $\text{standard ton refrigeration per } 24 \text{ h} = 12000 \text{ btu/h} = 3024 \text{ kcal/h}$
 $\text{atm} = 14.6959 \text{ lb./in.}^2 = 760 \text{ mm Hg (at } 0^\circ\text{C and } 45^\circ \text{ latitude)} = 101.325 \text{ kPa} = 1.01325 \text{ bar (=}$
 $33.899 \text{ ft. water} = 9.935 \text{ m of } 1040 \text{ wort)}$
 $\text{lb./in.}^2 = 6896.76 \text{ N/m}^2 = 0.06895 \text{ bar} = 703 \text{ kg/m}^3 = 27.7 \text{ inches water}$
 $\text{lb./gal. (British)} = 99.76 \text{ g/l}; \text{ lb./gal. (US)} = 119.8 \text{ g/l}$
 $\text{lb./brl (British)} = 3.336 \text{ g/l}; \text{ lb./brl (US)} = 3.865 \text{ g/l}$
 $\text{grain/gal (British)} = 14.25 \text{ mg/l}; \text{ grain/gal (US)} = 17.12 \text{ mg/l}$
 $\text{CO}_2 \text{ in beer: g/100 ml} = 5.06 \text{ v/v in beer}; \text{ v/v beer} = 0.198 \text{ g/100ml}$

Table A5 Specific gravity and extract table

The following table is based on those compiled by Dr Plato for the German Imperial Commission (*Normal-Eichungskommission*) and refers to the apparent specific gravities, as determined in the usual manner, by weighing in a specific gravity bottle in air or by means of a saccharometer. Cane sugar % w/v and % w/w represent g per 100 ml and g per 100 g of solution, respectively. The percentages by weight in column 6, corresponding with the specific gravities at 60°F given in column 1, were computed by interpolation from Plato's table for true specific gravities at 15°/15°C and 16°/15°C corrected to 60°/60°F and then brought to 60°F/60°F in air by adding $(SG - 1) \times 0.00121$. The cane sugar weight percentages were converted to volume percentages and the solution divisors calculated. The column headed Plato gives the specific gravities in air at 20°/20°C related to the cane sugar weight percentages and, with the latter, corresponds with the Plato table commonly used in breweries and laboratories where 20°C is the standard temperature. The column headed Balling similarly gives the specific gravities at 17.5°/17.5°C from the Balling table corresponding with the same sugar percentages. These specific gravities cannot accurately correspond with those at 60°/60°F and 20°/20°C on account of the errors in Balling's table. The following densities were used in the calculations:

Water at 15°C/4°C 0.999126
 60°F/4°C 0.999035
 20°C/4°C 0.998234

Specific gravity conversion table for cane sugar solutions

British units				Plato			
SG 60°F	Brewers' pounds	Cane sugar (% w/v)	Solution divisor	SG 20°C	Cane sugar (% w/w, Brix)	Balling SG 17.5°C	Baumé Modulus 145
1002.5	0.9	0.643	3.888	1.00250	0.641	1.00256	0.36
1005.0	1.8	1.287	3.885	1.00499	1.281	1.00513	0.72
1007.5	2.7	1.932	3.882	1.00748	1.918	1.00767	1.08
1010.0	3.6	2.578	3.879	1.00998	2.552	1.01021	1.43
1012.5	4.5	3.225	3.876	1.01247	3.185	1.01274	1.78
1015.0	5.4	3.871	3.875	1.01496	3.814	1.01528	2.14
1017.5	6.3	4.517	3.874	1.01745	4.439	1.01776	2.48
1020.0	7.2	5.164	3.873	1.01993	5.063	1.02025	2.83
1022.5	8.1	5.810	3.872	1.02242	5.682	1.02273	3.17
1025.0	9.0	6.458	3.871	1.02490	6.300	1.02523	3.52
1027.5	9.9	7.107	3.869	1.02740	6.917	1.02776	3.86
1030.0	10.8	7.755	3.868	1.02989	7.529	1.03027	4.20
1032.5	11.7	8.405	3.867	1.03238	8.140	1.03277	4.54
1035.0	12.6	9.054	3.866	1.03486	8.748	1.03527	4.88
1037.5	13.5	9.703	3.865	1.03736	9.352	1.03775	5.22

1040.0	14.4	10.354	3.863	1.03985	9.956	1.04024	5.55
1042.5	15.3	11.003	3.862	1.04234	10.554	1.04273	5.88
1045.0	16.2	11.652	3.862	1.04481	11.150	1.04523	6.21
1047.5	17.1	12.303	3.861	1.04731	11.745	1.04773	6.54
1050.0	18.0	12.953	3.860	1.04979	12.336	1.05022	6.87
1052.5	18.9	13.604	3.859	1.05227	12.925	1.05269	7.20
1055.0	19.8	14.255	3.858	1.05476	13.512	1.05515	7.52
1057.5	20.7	14.907	3.857	1.05726	14.097	1.05760	7.84
1060.0	21.6	15.560	3.856	1.05975	14.679	1.06005	8.16
1062.5	22.5	16.213	3.855	1.06224	15.259	1.06252	8.48
1065.0	23.4	16.866	3.854	1.06472	15.837	1.06500	8.80
1067.5	24.3	17.519	3.853	1.06720	16.411	1.06747	9.12
1070.0	25.2	18.173	3.852	1.06970	16.984	1.06995	9.44
1072.5	26.1	18.827	3.851	1.07218	17.554	1.07244	9.75
1075.0	27.0	19.482	3.850	1.07467	18.122	1.07494	10.06
1077.5	27.9	20.135	3.849	1.07717	18.687	1.07743	10.37
1080.0	28.8	20.791	3.848	1.07965	19.251	1.07990	10.69
1082.5	29.7	21.446	3.847	1.08213	19.812	1.08237	11.00
1085.0	30.6	22.101	3.846	1.08462	20.370	1.08486	11.30
1087.5	31.5	22.758	3.845	1.08712	20.927	1.08737	11.61
1090.0	32.4	23.414	3.844	1.08960	21.481	1.08986	11.91
1092.5	33.3	24.071	3.843	1.09209	22.033	1.09235	12.21
1095.0	34.2	24.726	3.842	1.09457	22.581	1.09481	12.51
1097.5	35.1	25.384	3.841	1.09707	23.129	1.09730	12.81
1100.0	36.0	26.041	3.840	1.09956	23.674	1.09980	13.11
1102.5	36.9	26.700	3.839	1.10204	24.218	1.10230	13.41
1105.0	37.8	27.360	3.838	1.10454	24.760	1.10480	13.71
1107.5	38.7	28.019	3.837	1.10703	25.299	1.10730	14.00
1110.0	39.6	28.679	3.836	1.10952	25.837	1.10983	14.30
1112.5	40.5	29.339	3.834	1.11200	26.372	1.11235	14.59
1115.0	41.4	30.000	3.833	1.11450	26.906	1.11486	14.88
1117.5	42.3	30.660	3.832	1.11698	27.436	1.11735	15.17
1120.0	43.2	31.321	3.831	1.11947	27.965	1.11984	15.46
1122.5	44.1	31.981	3.830	1.12195	28.491	1.12231	15.74
1125.0	45.0	32.643	3.829	1.12445	29.016	1.12478	16.03

Table A5 Continued

British units				Plato			
SG 60 °F	Brewers' pounds	Cane sugar (% w/v)	Solution divisor	SG 20 °C	Cane sugar (% w/w, Brix)	Balling SG 17.5 °C	Baumé Modulus 145
1127.5	45.9	33.305	3.828	1.12694	29.539	1.12729	16.31
1130.0	46.8	33.970	3.827	1.12944	30.062	1.12980	16.60
1132.5	47.7	34.632	3.826	1.13191	30.580	1.13228	16.88
1135.0	48.6	35.295	3.825	1.13441	31.097	1.13477	17.16
1137.5	49.5	35.958	3.824	1.13689	31.611	1.13723	17.44
1140.0	50.4	36.621	3.823	1.13938	32.124	1.13971	17.72
1142.5	51.3	37.285	3.822	1.14186	32.635	1.14221	18.00
1145.0	52.2	37.951	3.821	1.14435	33.145	1.14473	18.27
1147.5	53.1	38.617	3.820	1.14685	33.653	1.14727	18.55
1150.0	54.0	39.284	3.818	1.14934	34.160	1.14980	18.82

Table A6 Equivalence (approximate) between Institute of Brewing (UK) units of hot water extract

Litre %/kg (20°C) against lb/Qr (15.5°C, 60°F) in the body of the table. Calculated from the *Institute of Brewing Recommended Methods of Analysis* (1993), on the basis that for l°/kg (20°C) the equivalent values in the lb./Qr will be 0.5 greater than those for l°/kg (15.5°C). Example: 251 l°/kg (20°C) is equivalent to 84.1 lb./Qr (15.5°C); 251 l°/kg (15.5°C) is equivalent to 83.6 lb/Qr (15.5°C).

	240	250	260	270	280	290	300	310	320	330
0	80.2	83.7	87.2	90.8	94.2	97.8	101.3	104.8	108.3	111.9
1	80.5	84.1	87.5	91.1	94.6	98.1	101.7	105.2	108.6	112.2
2	80.8	84.4	87.9	91.4	94.9	98.5	102.0	105.5	109.0	112.6
3	81.2	84.8	88.3	91.8	95.3	98.8	102.4	105.9	109.3	112.9
4	81.5	85.1	88.6	92.1	95.7	99.2	102.7	106.2	109.7	113.2
5	81.9	85.5	89.0	92.5	96.0	99.5	103.1	106.6	110.1	113.6
6	82.3	85.8	89.4	92.8	96.4	99.9	103.4	106.9	110.4	113.9
7	82.7	86.1	89.7	93.2	96.8	100.2	103.8	107.3	110.8	114.3
8	83.0	86.5	90.1	93.5	97.1	100.6	104.1	107.6	111.2	114.6
9	83.4	86.8	90.4	93.9	97.5	100.9	104.5	107.9	111.5	115.0

Table A7 Solution divisors of some sugars at 20 °C (68 °F) (*Pauls' Malt Brewing Room Book* 1995–7, p. 231). The apparent solids content of a solution ($\text{g}/100 \text{ cm}^3$) = G/D where G is the excess specific gravity and D is the solution divisor

SG (approx)	D (sucrose)	D (invert sugar)	D (fructose)	D (glucose)	Wort solids
1016.0	3.872	3.875	3.907	3.805	–
1020.0	3.869	3.872	3.904	3.805	–
1028.0	3.864	3.866	3.900	3.805	3.92
1036.0	3.860	3.861	3.896	3.803	–
1061.0	3.849	3.845	3.882	3.794	3.90
1083.0	3.840	3.832	3.869	3.784	–
1106.0	3.831	3.819	3.853	3.772	–

Table A8 Some properties of water at various temperatures (various sources)

Temperature		–log Kw (pKw)	Oxygen content of air-saturated water		
°C	°F		(mg/l)	(mg/l)	(cm^3 at NTP/kg)
0	32	14.9435	–	14.35	10.19
5	41	–	–	12.73	8.9
10	50	14.5346	–	11.25	7.9
15	59	–	9.8	10.06	7.0
20	68	14.1669	8.8	9.08	6.4
24	75.2	14.0000	–	–	–
25	77	13.9965	8.1	8.25	5.8
30	86	13.8330	7.5	–	5.3
35	95	–	7.0	–	–
50	122	13.2617	–	–	–
60	140	13.0171	–	–	–

Table A9 The density and viscosity (η) at various temperatures of pure air-free water*

Temperature		η (cP)	Density (g/ml)
°C	°F		
–10	14	–	0.99812
Ice, 0	32	–	0.91700
0	32	1.787	0.99987
3.98	39.16	–	1.00000
5	41.00	–	0.99999
10	50.00	–	0.99973
15	59.00	–	0.99913
20	68.00	1.002	0.99823
30	86.00	–	0.99567
50	122.00	0.5468	0.98807
60	140.00	–	0.98324
65	149.00	–	0.98059
75	167.00	0.3781	–
80	176.00	–	0.97183
100	212.00	0.2818	0.95838

*Data of Weast (1977), Moll (1979)

Table A10 Some properties of water (Bak *et al.*, 2001; Moll, 1979)

Temperature		Specific heat (cal/g/K)	Latent heat of vaporization (cal/g)	Latent heat of fusion (cal/g)	Surface tension (dynes/cm)
(°C)	(°F)				
-6.62	20.1	—	—	76	—
0	32	1.00738	594.8	79.7 (approx)	75.6
10	50	1.00129	—	—	—
20	68	0.99883	—	—	72.75
100	212	—	539	—	58.90

The specific thermal capacity of water is 4.19 kJ/kg/°C, so the heat needed to raise the temperature of 1 m³ of water from 20 °C to 100 °C is 335 MJ. The latent heat of vaporization of water is 2.26 MJ/kg, so the heat needed to evaporate of 1 m³ water is 2260 MJ. Thus the total heat (energy) needed to vaporize of 1 m³ water, initially at 20 °C, is 2595 MJ.

Table A11 The relationship between the absolute pressure and the temperature of water-saturated steam

Pressure (bar)	Temperature	
	(°C)	(°F)
0.5780	85	185
0.7011	90	194
0.8453	95	203
1.000	99.6	211.3
1.01325	100	212
1.1	102.3	216.1
1.2	104.8	220.6
1.3	107.1	224.8
1.5	111.4	232.5
1.8	116.9	242.4
2.0	120.2	248.4
2.5	127.4	261.3
3.0	133.5	272.3
3.5	138.9	282.0
4.0	143.6	290.5
4.5	147.9	298.2
5.0	151.8	305.2
5.5	155.5	311.9
6.0	158.8	317.8
8.0	170.4	338.7
10.0	179.9	355.8
15.0	198.3	388.9
20.0	212.4	414.3
30.0	233.8	452.8
40.0	250.3	482.5
50.0	263.9	507.0

Table A12 The solubility of pure gases in water under 1 atmosphere pressure and at the temperatures shown. The volume of gas dissolved is given in ml, reduced to STP, that is at 0°C and 1 atmosphere pressure (760 mm of mercury at 0°C, at latitude 45°). (After Dawson *et al.*, 1987)

Temperature		Gas solubility (ml at STP/litre water)		
(°C)	(°F)	O ₂	N ₂	CO ₂
0	32	49	24	1713
5	41	43	21	1424
10	50	38	19	1194
15	59	34	17	1019
20	68	31	15	878
25	77	28	14	759
30	86	26	13	665
35	95	24	13	592
40	104	23	12	530
45	113	22	11	479
50	122	21	11	436

The gram molecular volume of an ideal gas at STP is 22.414 litres. The molecular weights of the gases are O₂ = 32.0; N₂ = 28.02; CO₂ = 44.01. Consequently 1 ml each (non-ideal) gas, at STP, will contain approximately oxygen, 1.428 mg; nitrogen, 1.250 mg and carbon dioxide, 1.964 mg (compare with Table 10.5).

Table A13 Salts in brewing liquors. Salt concentrations in brewing liquor are expressed in several different ways. This may be as the unit weight/unit volume, as in molarity (M, i.e. the gram molecular weight per litre) or as the equivalents per litre. Sometimes no account is taken of the fact that in dilute solution salts are nearly completely ionized, that is their component ions (cations, positively charged; anions, negatively charged) are separated in solution. Consequently it makes more sense to give the concentrations of the ions. At present these are usually expressed as mg (or µg)/litre. In the past concentrations were often expressed as millival, milligram equivalents/litre. When this is done the total concentration of the anions should equal the total concentration of the cations. The characteristics of some commonly encountered ions are indicated below. By ppm (parts/million) mg/litre are usually understood, but this is ambiguous and mg/kg may be intended

Ion	Symbol	Atomic/molecular weight	Equivalent weight
Calcium	Ca ²⁺	40.08	20.04
Magnesium	Mg ²⁺	24.32	12.16
Sodium	Na ⁺	23.00	23.00
Potassium	K ⁺	39.10	39.10
Bicarbonate	HCO ₃ ⁻	61.01	61.01
Carbonate	CO ₃ ²⁻	60.01	30.01
Sulphate	SO ₄ ²⁻	96.07	48.04
Chloride	Cl ⁻	35.48	35.48
Nitrate	NO ₃ ⁻	62.01	62.01
Nitrite	NO ₂ ⁻	46.01	46.01

Table A14 Units of degrees of water hardness. Equivalences between various units (degrees) of hardness in water. Total hardness usually means the sum of the calcium and magnesium expressed as equivalent amounts of CaO or CaCO₃. This convention is historically interesting, but irrational, since calcium carbonate has limited solubility and calcium oxide ('quicklime') reacts violently with water to give calcium hydroxide (After Moll, 1979; Benson *et al.*, 1997)

	French degree	English degree	German degree	Ca (mg/litre)	Ca (mM/litre)
1 French degree ^a	1.00	0.70	0.56	4.004	0.100
1 English degree ^b	1.43	1.00	0.80	5.73	0.143
1 German degree ^c	1.78	1.25	1.00	7.17	0.179
1 USA degree ^d	0.10	0.07	0.056	0.40	0.01
1 Calcium (mg/l)	0.25	0.175	0.140	1.00	0.025
Ca (millimoles/l)	0.00625	0.00438	0.0035	0.025	0.00063

^a CaCO₃, 10 mg/l; ^b 1 Clark degree, CaCO₃, 14.3 mg/l (1 grain/imp. gallon); ^c CaO, 10 mg/l; ^d CaCO₃, 1 mg/l.

Table A15 Some characteristics of raw materials and offal relevant to storage. The angle of repose is the angle from the horizontal adopted by materials when poured onto a flat surface. These values are somewhat variable depending on, for example, how well grain has been dressed, its moisture content and the variety. The valley angle is the included angle in the cone at the base of a silo or a store, which must not be exceeded if material is to run out freely (Briggs, 1998, Sugden *et al.*, 1999).

Material	Bulk density (kg/m ³)*	Angle of repose (degrees)	Maximum valley angle (degrees)
Barley	610–618	32	116
	520–750	23–35	–
Malt	510–550	30–45	90
	450–550	26	–
Malt grist, roller-milled	300–370	30–45	90
Malt grist, hammer milled	680–730	–	–
Rice (polished)	780–850	30	120
Rice (broken)	840–890	30	120
Rye	680–740	26	128
Sorghum	720–770	30–45	90
Oats	350–520	28–32	116
Wheat	780–830	30	120
Maize grits	630–700	30–45	90
Pelletized malt			
culms	560–640	–	–
Malt culms	224	50	–
Cereal dust	–	60	–

*The reciprocals of these values indicate the amount of storage space needed for each kilogram of material (that is m³/kg)

Table A16 Beer pasteurization; product temperature and lethal rate in Pasteurization Units, PUs. One PU is the lethal effect of holding for one minute at 60 °C (140 °F). Data selected from *Paul's Brewing Room Book*, 1998–2000, p. 271, where some practical considerations are considered

Product temperature		PU/min.
(°C)	(°F)	
53.0	127.4	0.10
55.0	131.0	0.19
56.5	133.7	0.32
57.5	135.5	0.45
59.0	138.2	0.72
60.0	140.0	1.0
61.5	142.7	1.7
63.0	145.4	2.7
64.0	147.2	3.7
65.0	149.0	5.2
66.5	151.7	8.6
67.5	153.5	12
69.0	156.2	19
70.0	158.0	27
71.5	160.7	45
72.5	162.5	62
74.0	165.2	100
75.0	167.0	139
76.5	169.7	231
77.5	171.5	320
79.0	174.2	519
80.0	176.0	720

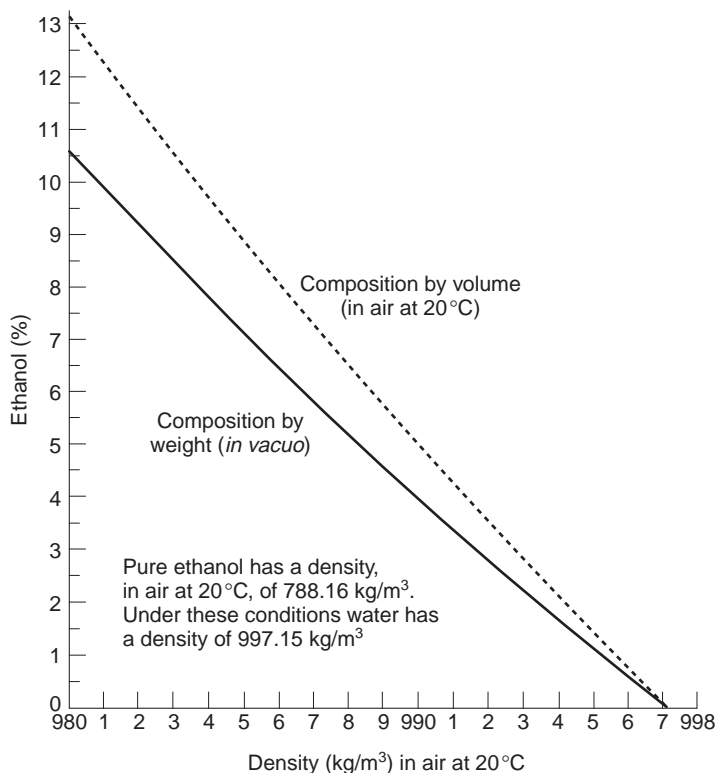

Fig. A1 The relationships between the densities (kg/m³) of alcohol (ethanol)/water mixtures, by volume in air at 20°C, or by mass *in vacuo*. Data from the *Brewing Room Book*, 1998–2000, p. 281, Pauls Malt, Ipswich and Kentford, Suffolk, UK.

References

- BAK, S. N., EKENGREN, Ö., EKSTAM, K., HÄRNULV, G., PAJUNEN, E., PRUCHA, P. and RASI, J. (2001) *Water in Brewing: a European Brewery Convention Manual of Good Practice*. 128 pp. Nürnberg. Fachverlag Hans Carl.
- BENSON, J. T., COLEMAN, A. R., DUE, J. E. B., HENHAM, A. W., TWAALFLLOVEN, J. G. P. and VINCKX, W. (1997) *Brewery Utilities: a European Brewery Convention Manual of Good Practice*. 200 pp. Nürnberg. Fachverlag Hans Carl.
- BRIGGS, D. E. (1998) *Malts and Malting*. p. 750. London: Blackie Academic & Professional. Gaithersburg: Aspen Publishing.
- DAWSON, R. M. C., ELLIOTT, D. C., ELLIOTT, W. H. and JONES, K. M. (1987) *Data for Biochemical Research*. (3rd edn). 580 pp. Oxford. The Clarendon Press.
- MOLL, M. (1979) in *Brewing Science*, **1**, (J. R. A. Pollock, ed.) p. 1. London. Academic Press.
- SUGDEN, T. D., WEBB, C., BYRNE, H., VAN WAESBERGHE, J. and WULFF, T. (1999) *Milling: a European Brewery Convention Manual of Good Practice*. 102 pp. Nürnberg. Fachverlag Hans Carl.
- WEAST, R. C. (ed.) (1977) *CRC Handbook of Chemistry and Physics*. (58th edn). Cleveland. CRC Press.

Index

<u>Index terms</u>	<u>Links</u>				
A					
abrasion	20				
absorption spectra	268	695	696		
ABV <i>see</i> alcohol by volume					
ACC genes	443				
accelerated shelf-life tests	701				
accelerating growth, phase of	474	475			
acetaldehyde	439	456	457	547	682
	683				
‘active acetaldehyde’ (8.36)	265	267			
acetaldehyde bisulphite compound	693				
acetaldehyde dehydrogenases	429	456			
acetic acid	601	683			
acetic acid bacteria	370	614	618		
<i>Acetobacter</i>	614	618			
α -acetoxybutyrate	455	456			
acetoin (9.16)	312	315	457	459	
α -acetolactate	455	456	459	684	
α -acetolactate decarboxylase	49	546	624		
acetone (8.15)	261	274			
1-acetonyl-2-pyrroline (9.39)	316				
acetyl Coenzyme A (acetyl-CoA)	422	443			
acetylacetone (8.16)	261	263			
acetylcarnitine	430				
2-acetylfuran (9.25)	313	314	690		
N-acetylglucosamine (11.2)	375	452			
4-acetylhumulinic acid (8.42)	269	270			
2-acetylpyridine (9.42)	316	690			

<u>Index terms</u>	<u>Links</u>		
2-acetylpyrrole (9.26)	314	691	
2-acetyl-1-pyrroline (9.38)	316		
5-acetyl-2,3-1 <i>H</i> -pyrrolizine (9.43)	316	317	
2-acetyl-1,4,5,6-tetrahydropyridine (9.40)	316		
2-acetyl-3,4,5,6-tetrahydropyridine (9.41)	316		
2-acetyl-4-tetrahydroxybutylimidazole (THAI) (9.51)	321	550	
2-acetylthiazole (9.48)	317		
2-acetylthiazolidine (9.46)	317		
2-acetyl-2-thiazoline (9.47)	317		
2-acetylthiophene (9.27)	313	314	690
acid/acid products	42		
acid/enzyme products	42		
acid-malts	29	116	
acid washing	636		
acidic detergents	644		
acidification	79	592	
acidification power test	505		
acidified wort	29	116	
acids	327		
α -acids <i>see</i> alpha-acids			
in beer			
non-volatile	672	674	
volatile	677	683	
β -acids <i>see</i> beta-acids			
ACP <i>see</i> acyl carrier protein			
acridine orange	611		
acrosipire length	16	25	
activated sludge systems	75		
‘active acetaldehyde’ (8.36)	265	267	
active charcoal	119		
active transport	412		
acyl carrier protein (ACP)	443		
addition of yeast <i>see</i> pitching			

<u>Index terms</u>	<u>Links</u>				
adenine (4.56)	146	147	689		
adenosine triphosphate (ATP) (4.53)	146	147	148	404	418
bioluminescence	612				
sugar metabolism	424	425	426	434	
S-adenosylmethionine	381	462			
adenylate energy charge	505				
ADH genes	429				
adhesion	704				
adhesives	768				
adhulupone (8.85c)	257	261			
adhumulone (8.1c)	256	258	259	261	
adjunct mash	4	93			
adjuncts	34	89	608		
copper adjuncts	4	34	40	101	327
mash tun adjuncts	2	34	101	145	
mashing with	101				
starch-containing	134				
adlupulone (8.2c)	256				
adprehumulone (8.1f)	259				
adsorbents	6				
adsorption	557	559			
AEDA <i>see</i> aroma extract dilution analysis					
aeration					
water treatment	57				
wort	4	356	359	519	
aerobic effluent treatments	75				
aerobic sterol exclusion	416	447			
aerobic wort propagation	489				
AFLP <i>see</i> amplified fragment length polymorphism					
African beers	5	7	485	589	
attempts to obtain stable beers	601				
beer composition and nutritional value	602				
bouza	589	590			

Index terms**Links**

African beers (<i>Continued</i>)				
busaa and similar drinks	591			
industrial scale brewing	597			
malting sorghum and millets	593			
merissa	591			
methods for southern African beers	592			
stages of production	590			
after-flavour terminology	752			
AG <i>see</i> amyloglucosidase				
agamantine (4.72)	148	150		
agar slopes (slants)	485			
agarose	495			
ageing, yeast	404	482		
agitation	310	523		
agitator	334	335		
agrochemicals	240	241	243	
air entrainment	89			
air rests	15			
air-water partition coefficient	720			
ajou	592			
α -alanine (4.24)	144	148	450	687
β -alanine (4.25)	144			
albumins	142			
alcohol by volume (ABV)	7	9	665	670
alcohol content	7	9	665	
African beers	590			
alcohol dehydrogenase	456			
alcohol-free beers	7	582	667	
alcohol table	665	668		
alcohols	707	708		
higher alcohols	459	461	676	681
Alcolyzer	667			

<u>Index terms</u>	<u>Links</u>				
aldehydes	156	456	547	676	682
	731				
Strecker reaction	319				
aldose reductase	456				
ale yeasts	499				
ales	5	7	479	526	754
maturation methods	548				
aleurone layer	12	13			
pigmentation	14				
alkaline steeps	597				
alkaline waste liquors	71				
all-adjunct mashes	94				
all-malt grists	177				
allantoin (4.61)	146	147			
alloaromadendrene (8.127)	286	291			
alloaromadendrene epoxide (8.130)	291	292			
allo-iso- α -acids (8.41)	257	269	270		
allosteric modulation	406				
alpha-acids (α -acids) (8.1)	227	256	257	265	266
conductometric titration	267				
isomerization of	269				
oxidation products	282				
aluminium	788				
aluminium foil	768				
aluminium kegs	793				
aluminium sulphate	59				
Amadori compounds (9.3 and 9.4)	311				
amber malts	31				
American Society of Brewing Chemists (ASBC)	8	85			
colour of beer	696				
haze	698	699	701		
malt analyses	22				
amides	689				

<u>Index terms</u>	<u>Links</u>				
amines	146	689	691		
amino acids	603				
classification of wort amino acids	450				
composition of beers	687	688			
mashing	109	111	142		
nitrogen metabolism	449	452			
uptake by yeast	415	416			
in worts	309	310	311		
<i>o</i> -aminoacetophenone (19.7)	688				
α -aminoadipic acid (4.26)	144				
γ -aminobutyric acid (4.27)	144	145			
2-aminoethylmercaptan <i>see</i> cysteamine					
ammonia	54	67	146	523	524
	553	689			
ammonia caramels	321				
ammonium ions	54	67	146	415	451
ammonium persulphate	637				
amphibolic pathways	424				
amphoteric surfactants	647				
amplification	392				
amplified fragment length polymorphism (AFLP)	392				
AMV <i>see</i> arabis mosaic virus					
α -amylase	24	47	111	129	132
	134				
fungal	45	46			
salivary	591				
β -amylase	47	111	129	131	134
	136				
amyloglucosidase (AG)	45	48	600		
amylopectin	128	129	130	131	
amylose	128	130			
anabolic route for higher alcohols	460	461			
anabolism	404				

<u>Index terms</u>	<u>Links</u>			
anaerobic cultures	628			
anaerobic effluent digestion treatments	79			
analysis of variance (ANOVA)	756			
analytical mashing programmes	23			
analytical systems	7	9		
anaplerotic pathways	424			
aneuploidy	372	383		
angle of nip	177			
angle of repose	845			
anionic surfactants	646			
annular filtration lauter tun	207			
anosmia	721			
ANOVA <i>see</i> analysis of variance				
ANTC <i>see</i> apparent total N-nitroso compounds				
anthocyanogens <i>see</i> proanthocyanidins				
anthrone	670			
antibiotics	636			
antibodies	500			
antigens	500	686		
anti-oxidants	165			
apoptosis	483			
apparent attenuation limit	511			
apparent degree of fermentation	669			
apparent extract	669			
apparent total N-nitroso compounds (ANTC)	621			
approximate formula	670			
APV continuous mashing system	221			
aquifers	53			
arabinose (4.11)	125	140	142	670
arabinoxylan	702	707		
arabis mosaic virus (AMV)	247			
arginine (4.28)	144	148	450	687

Index terms**Links**

aroma <i>see</i> odour/aroma				
aroma extract dilution analysis (AEDA)	297	300	733	
'aroma' hops	227	249	285	350 550
aromadendrene (8.128)	286	291		
aromadendrene epoxide (8.131)	291	292		
aromatisation	188			
arrayers	393			
arsenic	665			
Artois Unitank system	77			
ASBC <i>see</i> American Society of Brewing Chemists				
asbestos	771			
ascorbic acid (4.96)	149	152	165	731
ascospores	387			
ascus	387			
aseptic filling	6	779	796	
aseptic sample processing	635			
ash	163	255		
asparagine (4.30)	144	145	450	
aspartic acid (4.29)	144	450	687	
astragalin (8.173)	302			
asymmetric heating panels	334			
asynchronous cultures	474			
ATP <i>see</i> adenosine triphosphate				
attenuation, degree of	510			
attenuation limit	24	88	511	
austenitic stainless steels	516			
autolysis	483			
automation				
brewhouse	657			
cleansing regimes	640			
keg cleaning and filling machines	797			
lauter tuns	210			
yeast pitching systems	521			

Index terms**Links**

autoxidation	274	281	730		
auxiliary finings	807				
B					
<i>Bacillus</i> spp.	621	622			
enzymes from	47	48	49		
bacteria, spoilage	613				
biochemical properties	614	615			
gram negative	614	614			
gram positive	613	614	621		
identification	613	615	616		
bacterial cell wall hazes	555	561			
bacterial enzymes	47				
badge engineering	549				
baker's yeast	490				
balancing/conditioning tank	75				
Balling table	7	23	85	660	838
Balling's equation	669				
banana esters	683				
BAPS Microbiology	629				
barcodes	802				
barley	11	123			
adjuncts	36	37	38	102	145
purchasing	14				
structure of barley corn	12				
<i>see also</i> malts and malting					
barley amylase/subtilisin inhibitor (BASI)	130				
barley brewing	35	102	104		
'barm' ale	529	571			
Barnes neck	793				
basal media	499				
BASI <i>see</i> barley amylase/subtilisin inhibitor					
batch culture, yeast	474				

<u>Index terms</u>	<u>Links</u>			
batch fermentation	402			
batch sizes	510			
beer	662			
analyses	662	663	664	
chemical composition	310	311	662	
alcohol and original extract	665			
carbohydrates	670			
constituents containing carbon, hydrogen and oxygen	664	672		
inorganic constituents	664	666		
nitrogenous constituents	664	685		
sulphur-containing constituents	664	691		
colour	695			
composition of African beers	602			
flavour <i>see</i> flavour				
foam characteristics and head retention	703	830		
gushing	26	100	608	710
haze <i>see</i> haze				
nutritive value	602	694		
perception of quality	6			
qualities	6			
strength	7	9	665	
types of	6			
viscosity	702			
‘beer bitter substances’	257			
beer cellars	820			
beer dilution	9	544	551	
beer dispense systems	821			
bottled and canned beer	830			
cask beer	824			
keg beer	822			
beer engines	827	828		
beer filling valve	802			
beer film	522			

<u>Index terms</u>	<u>Links</u>			
beer filtration	574			
beer lines	824	825		
cleaning	647	824		
beer maturation <i>see</i> maturation				
beer powders	601			
beer pumps	822	823		
beer recovery <i>see</i> recovery of beer				
beer sarcina	685			
beer spoilage organisms	610			
beer stone	65	163	526	824
Belmalt process	29			
bentonite	702			
benzoic acids, substituted	157			
best estimated threshold (BET)	742			
beta-acids (β -acids) (8.2)	256	258	265	276
oxidation products	281	284		
β -fraction	256			
BHT <i>see</i> butylatedhydroxytoluene				
bicarbonate ions	67			
bicyclogermacrene (8.114)	286	289	291	
bifenthrin (7.6)	241			
bifurcose (4.22)	125	128		
biguanides	647			
bioaccumulation	416			
biochemical tests	499			
biofilms	498	610	638	
biofiltration towers	77			
biogas	78	79		
biological haze	697			
biological oxygen demand (BOD)	69	73	74	
bioluminescence reaction	612			
bioluminometer	612			

<u>Index terms</u>	<u>Links</u>		
biomass measurement	470		
biosorption	416		
biotin (4.98)	151	152	411
birdproof sorghums	103	594	
birefringence	129		
BIRM filters	58		
birth scar	374		
‘bitter’ hops	249		
bitter taste	718	723	725
bittering value	280		
bitterness units (BU)	270	673	
black malts	31		
blending			
beers	551		
malts	18	101	
Blom, J.	704	705	
Boby mill	178		
BOD <i>see</i> biological oxygen demand			
body	717		
body-feed	578		
boil <i>see</i> wort boiling			
boiler water	65		
boilers <i>see</i> coppers			
booths	733		
boreholes	53		
bottle conditioning	602		
bottle-washing machine	764		
bottled beer	602	830	
bottling and bottles	9	759	761
arrangement of bottling equipment	762	763	
managing the beer flow	770		
managing the bottle flow	762		
managing plant cleaning	785		

Index terms**Links**

bottling and bottles (<i>Continued</i>)				
materials for bottles	786			
sequence of bottling	772			
bottom fermentation systems	509	514		
choice, size and shape of vessels	514			
construction of cylindroconical vessels	516			
operation of cylindroconical vessels	519			
bottom yeasts	5	377	402	484
bound water	118			
bouza (bouzah or bowza)	589	590		
Bradford Coomassie Blue dye binding assay	707			
branded glasses	830			
'break point'	17			
<i>Brettanomyces</i>	628			
Brewer's Gold hops	248			
brewery batch fermentations	477			
brewery conditioned beer	543	548		
brewery microbial contaminants	610			
brewery microbiological laboratories	629			
brewery yeast propagation	487	491		
brewhouses	650			
control of operations	657			
economics	660			
history of development	650			
modern	654			
sizes	654			
brewing liquor	2			
<i>see also</i> water				
brewing rice	39			
'brewpubs'	655			
Bri vitality apparatus	505			
British beer types	7			
British lager malts	27			

<u>Index terms</u>	<u>Links</u>		
bromelin	49	557	
brown ales	663		
brown malts	31		
Brumalt	28		
BU <i>see</i> bitterness units			
bubbles	703	704	
Büchner, L.	365		
bud scars	374	482	
budding yeasts	384	482	
budding index	477		
BuEhler-Miag disc mill	178		
bulk density	845		
bulk flow systems	174		
Bullion hops	248		
bupirimate (7.15)	242		
Burns method	501		
Burton Union fermentation	531		
Burtonization	64	115	
burukutu	592		
busaa	591		
butane-2,3-dione <i>see</i> diacetyl			
butylatedhydroxytoluene (BHT) (20.11)	723		
by-products	68		
characteristics	71		
 C			
C ₄ to C ₁₀ fatty acids	547		
cadaverine (1,5-diaminopentane) (4.75)	148	150	691
α-cadinene (8.122)	290		
γ-cadinene (8.121)	286	290	
δ-cadinene (8.118)	286	290	
α-cadinol (8.124)	290	292	
δ-cadinol (8.123)	290	292	298

<u>Index terms</u>	<u>Links</u>				
<i>T</i> -cadinol (8.125)	290	292	298		
caffeic acid (4.130)	157	158			
caffeine (20.2)	718	719	723	724	
Cagniard-Latour, Charles	364				
calamity tank	73				
calcium alginate	495				
calcium bicarbonate	60				
calcium carbonate	526				
calcium ions	65	113	115	378	417
	664	666			
calcium oxalate	65	116	163	526	555
	561	700	711		
calcofluor	25	374	670		
calorific value	694				
Campaign for Real Ale (CAMRA)	805				
camphene (8.103)	288	289			
CAMRA <i>see</i> Campaign for Real Ale					
can lids	788				
candicine (4.84)	148	150			
<i>Candida</i>	627				
candle filters	581				
<i>Cannabis</i>	228				
canned beer and canning	9	759	787	830	
can closing	790				
cans	787				
filling	789				
preparing cans for filling	788				
widgets	792				
capacitance biomass probe	471				
capping, kegs	802				
capric acid	547				
caprylic flavour	727				
capsule tops	768				

<u>Index terms</u>	<u>Links</u>				
caramel malts	32				
caramels	4	11	45	311	549
	695				
classes of	320				
carbohydrases	141				
carbohydrates	555	561	700		
composition of beer	670				
fermentability	125				
storage carbohydrates and sugar metabolism	430				
total carbohydrate (TC)	109				
in wort	108	122	307	308	
interactions with nitrogenous constituents	311				
carbon					
beer constituents containing	664	672			
dissolved organic carbon (DOC)	69				
sources in yeast nutrition	409				
carbon dioxide	5	19	402	518	549
canned beer	792				
carbonation <i>see</i> carbonation					
collection	71				
content in beer	665	761			
dispense system for keg beer	822				
fermentation control and partial pressure	540				
flushing	549	774	775		
hop extracts	238	285			
top fermentation systems	528				
carbon dioxide purging	564				
carbon filtration	63				
carbonate ions	67				
carbonation	6	543	562		
carbon dioxide addition	564				
carbon dioxide recovery	565				
carbon dioxide saturation	562				
carbonation stone	564				

<u>Index terms</u>	<u>Links</u>				
carbonation unit	564	565			
carbonyl compounds	456	463	731		
<i>see also</i> aldehydes; vicinal diketones					
cardboard flavour	730				
Carman-Kozeny equation	122				
κ -carrageenan	322	323	327	495	
Carter-Simon disc separators	20				
caryolan-1-ol (8.138)	292	298			
caryophyllene (8.136)	286	291	292	295	
caryophyllene epoxide (8.137)	291	292	295	296	
caryophyllene/humulene ratio	302				
caryophyllene/selinene ratio	302				
Cascade hops	298				
cascade open continuous fermentation system	532	533			
Casella mill	178				
cask beer	529	543	609	759	805
	820	821			
casks	805				
dispense systems	824				
filling	808				
handling casks	806				
preparing beer for cask filling	807				
cask conditioning	548				
catabolic route for higher alcohols	460	461			
catabolism	404				
catabolite inactivation	430	435			
catabolite repression	401	413	414	415	428
	435	452	465	475	
catalase	49	442	729		
catalytic combustion	667				
catechin (4.138)	158	159	160	301	322
	673				
cationic surfactants	646				

<u>Index terms</u>	<u>Links</u>				
catty flavour (Ribes)	732				
caustic soda	644				
cavitation	703				
CCPs <i>see</i> critical control points					
CDKs <i>see</i> cyclin-dependent kinases					
cell component vitality tests	505				
cell composition yeast identification methods	501				
cell counts	470	472	611		
cell cycle, yeast	384				
sexual cycle	387				
cell envelope	373	375			
cell lysis	476				
cell size, yeast	372				
cell surface properties	500				
cell wall, yeast	374	412			
cellobiose (4.18)	122	125	127	139	670
cellulases	48	102	113		
centiMorgans	390				
centrifugation	351	355	569		
centring bell (tulip)	773				
centromere	383				
ceramic cylinder supports	496				
cereal cookers	4	200			
cereal syrups	41	43			
CFCs <i>see</i> chlorofluorocarbons					
cfu <i>see</i> colony forming units					
chalconaringenin (8.55)	277	278			
chemical oxygen demand (COD)	60	69			
chemicoreceptors	717				
chemiosmotic theory	426				
chemostats	492				
Chibuku Zimbabwe/Botswana process	600				

Index terms**Links**

Chibuku Zimbabwe/Malawi process	600				
chill hazes	161	555	556	575	698
chip sugar	42				
chit malts	26				
chitin	375	376	452	495	
chloride ions	67	664	666		
chlorine	59				
chlorine dioxide	59	646			
chlorofluorocarbons (CFCs)	524				
chlorogenic acid (4.133)	157	158	301		
chlorothalonil (7.13)	242				
chocolate malts	31				
choline (4.101)	151	152	688		
chondrione	382				
<i>Chondrus crispus</i>	322				
chroma	696				
chromatin	383				
chromogenic media	498				
chromosomes	383				
CIELAB colour space	696				
cinnamic acids, substituted	157				
CIP <i>see</i> cleaning in place					
circumvallate papillae	717	718			
citral	288				
citrate methylene violet	502				
citrate synthase	424				
citric acid (4.153)	161	162	409	674	
citric acid cycle	422				
Citrobacter	617	618			
citronellol (8.96)	287	289			
clarification					
beer	6	543	567		

Index terms**Links**

clarification (<i>Continued</i>)					
beer filtration	574				
centrifugation	569				
filtration	571				
sedimentation and fining	567				
wort	4	119	209	223	323
	349				
Clarity malt	560				
cleaning	331	336	637	761	
beer cellars	820				
beer lines	647	824			
bottling plant	785				
brewing process stages and	638	640			
cask beer dispense system	827				
casks	806				
cleaning agents	644	764			
kegs	796				
range of cleaning operations	640				
regimes	639				
water for	65				
cleaning in place (CIP)	203	638	639	640	641
	643				
CIP sets	643				
CIP spray head	518				
cleaning sequence	525				
fermentation vessels	525				
maturation vessels	554				
sterile filtration	772				
validation	648				
CLG genes	433				
cling	704				
cluster analysis	754				
Clusters hops	248				
coagulable nitrogen	24	88			

<u>Index terms</u>	<u>Links</u>				
coagulants	58	75			
coalescence	703				
coarse filtration	58				
cobalt	665	711			
cocci	62				
COD <i>see</i> chemical oxygen demand					
Coenzyme A esters (8.30)	265	266			
cohobation	239				
cohulupone (8.85b)	257				
cohumulone (8.1b)	256	258	259		
cold break	4	323	324	356	358
	528	575			
cold contact process	584				
cold water extract (CWE)	16	22	86	660	
coliforms	617				
collagen	568				
collecting vessel	528				
colonies, yeast	372	497			
colony growth	497				
colonization immobilized yeast reactors	496				
colony counts	502	611			
colony forming units (cfu)	502				
colour	4	145	695		
adjustments	549				
colour blindness	696				
colour temperature	696				
coloured malts	11	18	23	31	
colupulone (8.2b)	256	258	263	280	
combined stabilization treatment	561				
commercial brewing	589	603			
commercial hop oil	285				
commercial yeast identification kits	499				

<u>Index terms</u>	<u>Links</u>			
compatible solutes	408			
competition	815			
composite delivery	816			
Concanavilin A	378			
concentrated worts	602			
condensation				
heterogeneous and homogeneous	703			
problems in fermenting rooms	527			
conditioned dry milling	184			
conditioning <i>see</i> maturation				
conditioning (balancing) tank	75			
conical-bottomed steepers	20			
constitutive genes	406			
continuous brewing	8	221		
continuous culture (of yeast)	492			
continuous diacetyl removal	497			
continuous fermentation	221	469	494	532
early systems	533			
immobilized yeast systems	535			
New Zealand system	535	536		
continuous filling	516			
continuous high-pressure boiling	343	344		
continuous mashing system	221			
control of metabolism	405			
control systems				
brewhouse operations	657			
fermentation	539			
filling	801			
temperature	521			
controls (reference substances)	736			
conveyors	19	171		
coolants	357			

Index terms**Links**

cooling					
fermentation systems	513	517	522		
maturation vessels	552				
wort	4	344	356		
cooling jackets	517	522	553		
coolships	350	356			
copaene (8.119)	286	290			
copper adjuncts	4	34	40	101	327
copper condensers	346				
copper finings	322	327			
copper ions	66	417	665		
copper (kettle)-whirlpools	4	306	340	350	352
coppers (kettles/boilers)	4	200	306	326	328
types of	332				
corks	780				
corrosion inhibitor	553	766			
Coulter counter	520				
<i>p</i> -coumaric acid (4.129 and 8.54)	157	158	277	278	682
Council for Scientific and Industrial Research (CSIR)	590				
Coutts, Morton	532	535			
Crabtree effect	434				
‘crash cooling’	514				
crating	763				
critical control points (CCPs)	633				
critical size (yeast cells)	386				
cross-flow filtration	221	355	571	573	
crowning	780				
crude protein	63	88			
cryoprotectant	486				
crystal malts	32				
CSIR <i>see</i> Council for Scientific and Industrial Research					
CTR1 gene	417				

<u>Index terms</u>	<u>Links</u>				
cullet	786				
culms <i>see</i> rootlets					
culture media	497	498	611	628	
curing	18				
Custer's effect	435	438			
cutting	786				
CuZn SOD	442				
CWE <i>see</i> cold water extract					
cyanide insensitive respiration	428				
cyanidin (4.136)	157	159	301		
cyanidin:delphinidin ratio	301				
cyclic AMP-dependent protein kinase cascade	433	435	454	475	
cyclin-dependent kinases (CDKs)	387				
cyclins	387				
cyclohexane-1,3,5-trione (8.19)	262				
cyclohexane-1,3,5-trioxime (8.21)	262				
cyclones	173	221			
cyclopentane-1,3-dione	711				
5 <i>H</i> -cyclopentapyrazine (9.35)	318				
cyfluthrin (7.2)	241				
cylindroconical fermentation vessels	514				
<i>p</i> -cymene (8.100)	288	289			
cypermethrin (7.1)	241				
cysteamine (9.45)	317				
cysteine (4.31)	142	143	144	163	410
	450				
cystine (4.32)	142	143	144	163	
cytochromes	425				
cytokinesis	384	386			
cytoplasm	380				
cytosine (4.58)	146	147	689		

Index terms**Links****D**

dagger nematode	247			
β -damascenone (8.165)	294	733		
damson-hop aphid	240			
Darcy's equation	122	222		
date stamp	769	788		
DE <i>see</i> dextrose equivalent (DE) value				
DEAE cellulose	496	546		
deaerated water	63	551		
dealkylation	61			
death phase	475	476		
debranching enzymes	47	132	133	
decanter clarifiers	351	571		
decelerating growth phase	475			
decoction mashing	3	89	189	199
decolourised <i>p</i> -rosaniline	693			
de-crating	763			
deep-shaft reactor	76			
defined media	629			
deflector plate	336	337		
defoliants	231			
DEFT <i>see</i> direct epifluorescent filter technique				
degrees Lintner (°L)	24			
dehydrated humulinic acid	711			
dehydroascorbic acid (4.97)	149	152	731	
dehydrocycloanthohumol (8.63)	277	279		
dehydrocycloanthohumol hydrate (8.64)	277	279		
dehydrohumulinic acid (8.10)	260	281		
dehydrohumulone (8.51a)	275	277		
<i>Dekkera</i>	628			
delivery	816	826		
delphinidin (4.135)	157	159	301	

<u>Index terms</u>	<u>Links</u>			
delphinidin:cyanidin ratio	301			
deltamethrin (7.3)	241			
demineralization	62			
denatonium benzoate (20.5)	718	719		
denatonium chloride	718	719		
'denatured' protein	142	309		
deoxy- α -acids (8.26)	264	265	266	280
deoxygenation of water	63	551		
3-deoxyglucosone (9.6, R=CH ₂ OH)	312	313		
deoxynivalenol	608	711		
1-deoxyosone (9.9)	312	313		
3-deoxyosone (9.6)	312	313		
deoxyribonucleic acid (DNA) (4.50)	146	147	383	
DNA analysis of hops	251			
DNA microarrays (DNA chips or gene chips)	393			
DNA typing	302			
recombinant DNA technology	391	396		
4-deoxyribose (4.52)	146	147		
1-deoxyxyulose-5-phosphate (8.37)	265	267		
de-palletization	762	796		
dephosphorylation	406	407		
depth filtration	575	576	771	
desalination	53			
description analysis	742			
design				
plant	641			
vessels	516			
desmethylxanthohumol (8.60)	277	278	279	
de-stacking	796			
de-stoner	174			
detection threshold	722	723		
detergents	644	764		
dextrinogenic amylase	130			

<u>Index terms</u>	<u>Links</u>				
dextrins	109	123	125	130	670
	702				
dextrose equivalent (DE) value	42				
dhurrin (4.88)	149	150	595		
diacetyl (9.14)	312	315	316	456	545
	624	684	722		
continuous removal	497				
diacylglycerol	446				
‘dial a pipe’ system	517				
dialysis	583	686			
diaphragm-type sample cocks	634				
diastase	129				
diastatic malt extract	587				
diastatic power (DP)	24	129	595		
diastatic yeasts	626				
diauxic shift	410	429	475		
2,6-dichlorophenolindophenol (20.10)	731				
dielectrical permittivity	471	504	521	540	
diet beers	7	92	122	582	586
diethylaminoethylcellulose	496	546			
difference threshold	722				
differential media	629	631			
diffusion	411				
digalactosyl diglyceride (4.115)	154	155			
1,2-diglyceride (4.104)	153	155			
1,3-diglyceride (4.105)	153	155			
dihydro-2(3 <i>H</i>)-furanone (19.3)	684				
dihydrohumulinic acid (8.4a)	258	260			
dihydrohumulone (8.45)	275	276			
1,3-diisopentylcyclopentane (8.11)	258	260			
di-isoprenylphloracylphenone (deoxy- α -acids) (8.26)	264	265	266	280	
di-isoprenylphloracylphenone (gem) (8.27)	264	265			

<u>Index terms</u>	<u>Links</u>				
diketones, vicinal	429	455	456	545	684
	731				
dilution	9	544	551		
dilution rate	493				
dimethyl sulphide (DMS) (4.158)	25	99	165	319	327
	463	546	620	691	693
	722	732			
dimethyl sulphide precursor (DMS-P) <i>see</i> S-methylmethionine					
dimethyl sulphoxide (DMSO) (4.160)	165	463	546	620	691
	693				
dimethyl trisulphide	296				
dimethylallyl bromide (8.24)	264				
(γ,γ)-dimethylallyl pyrophosphate (8.34)	265	266	286	287	
dimethylamine (4.78)	148	150	690	691	
5,5-dimethyl-(5H)-2-furanone (8.70)	281	282	294		
2,5-dimethyl-4-hydroxy-3(2H)-furanone <i>see</i> furaneol					
diphosphatidyl glycerol (4.119)	154	155			
diplophase	388				
diquat (7.18)	231	243			
direct cooling	517				
direct epifluorescent filter technique (DEFT)	611	613			
direct expansion cooling system	524				
direct heating	328				
directional difference test	736	737			
disaccharide carriers	414				
disc mills	182	187			
discriminant analysis	754				
diseases, hop	236	244			
disinfectants	646				
disinfection of pitching yeast	636				
dispense	819				
<i>see also</i> beer dispense systems					

Index terms**Links**

dispense head nozzle design	831				
dispersion chamber	187				
disproportionation	703				
dissolved organic carbon (DOC)	69				
dissolved oxygen (DO)	63	360	610		
distillation method	665				
distribution	812	815			
disulphide bridges	309				
DMS <i>see</i> dimethyl sulphide					
DMS-P <i>see</i> S-methylmethionine					
DMSO <i>see</i> dimethyl sulphoxide					
DNA <i>see</i> deoxyribonucleic acid					
DO <i>see</i> dissolved oxygen					
DOC <i>see</i> dissolved organic carbon					
double-deck tunnel pasteurizer	783	784			
double decoction mashing	91	92	94		
double filters	214				
double mashing system	3	93	102	103	199
double pass filtration	575				
double seaming process	790				
double seat valves	517				
doubling time	476				
doughing in <i>see</i> mashing in					
downy mildew	244				
DP <i>see</i> diastitic power					
draff <i>see</i> spent grains					
drainage	703				
draining	209				
draught beer	609	759	760		
dressing grain	2	17	18		
dried brewers' solubles	72				
dried yeast	485				

<u>Index terms</u>	<u>Links</u>				
drinking water standards	54	56			
dropping bright	826				
dropping system	528				
dry goods handling	171				
dry hop essence	300				
dry hopping	227	285	300	301	809
dry milling	178	179			
dry roller milling	179				
dry weight method for yeast biomass	470	472			
drying					
grain	19				
hops	234				
dual-purpose fermenting/maturation vessels	552	553			
Dumas combustion method	685				
duo trio test	736	741			
dust	18	173			
dust explosions	173				
dwarf hops	234	249			
dynamic disc mash filtration technique	221				
dynamic low-pressure boiling	343				
dynamic viscosity	702				
dynein	385				
 E					
EBC <i>see</i> European Brewery Convention					
economics	8				
brewhouses	660				
economies of scale	651				
economizers	346				
eddy currents	353	354			
EDTA <i>see</i> ethylene diamine tetra acetate					
efficient operations	8				

Index terms**Links**

effluents	68		
characteristics of wastes and by-products	71		
characterization of waste water	69		
disposal	73		
aerobic treatments	75		
anaerobic and mixed treatments	79		
preliminary treatments	73		
sludge treatments and disposal	78		
Ehrlemeyer flask	635		
Ehrlich route to higher alcohols	460	461	
eigenvectors	754		
eight-roll mills	180		
electron capture detector	684		
electron microscopy	373		
electron transport chain	382	425	
electronic image analysis	504		
electronic 'noses'	716		
electronic particle counters	470	472	
electroporation	392		
elevated temperature boiling	331	342	344
elevators	19	171	
ELISA <i>see</i> enzyme-linked immunosorbent assay			
ELO genes	445		
Embden-Myerhof-Parnas pathway (glycolysis)	418		
embryo	12	13	16
empty bottle inspection	766		
empty casks	829		
empty containers	813		
enclosed equipment	641		
enclosed fermentation vessels	531		
endocytosis	381		
endoplasmic reticulum	381		

<u>Index terms</u>	<u>Links</u>				
energy	8	307	770		
conservation and the hop boil	345				
<i>see also</i> heat					
energy storage tank	346				
energy value	694				
<i>Enterobacteriaceae</i>	617				
Entner-Duodoroff pathway	617	620			
entrapment immobilized yeast systems	495	536			
environmental microbial surveys	636				
enzyme/enzyme products	42				
enzyme-linked immuno-absorbent assay (ELISA)	500	686			
enzymes	11	45	587		
added to malts	29				
breakdown of β -glucans	137				
denaturation and inactivation	327				
enzymatic method for alcohol content	667				
enzymatic method for sulphur dioxide	693				
hydrolytic	16				
mashing	86	89	103		
microbial	2	47			
non-malt enzymes in mashing	110				
optima and enzyme activities	86				
proteolytic	49	557	702		
supplementary	46				
temperature and enzyme activities	307				
epicatechin (4.139)	158	159	301	322	673
epidemic gushing	710				
epigallocatechin (4.141)	158	159			
epiglobulol (8.135)	291	292			
epiheterodendrin (4.86)	149	150			
epoxides (oxiranes)	290				
<i>trans</i> -4,5-epoxy-(E)-2-decenal (8.171)	297	298			
12,13-epoxy-9-hydroperoxy-11-octadecenoate (8.170)	297	298			

Index terms**Links**

ergosterol	380	447	448	449	711
2-C-erythritol 4-phosphate (8.39)	265	267			
essential amino acids	603				
essential oil, hop <i>see</i> hop oil					
esterases	141	155			
esters	445	449	460	678	683
etching (glass)	766				
ethanal <i>see</i> acetaldehyde					
ethanoic acid <i>see</i> acetic acid					
ethanol (ethyl alcohol)	5	402	607	708	
ethanol-water mixtures	847				
fermentative sugar catabolism	428				
hop extract	238				
toxicity and tolerance in yeast	438				
ethyl acetate	683				
ethyl carbamate (urethane)	149	150	689	691	
ethylamine (4.65)	148	150	691		
ethylene diamine tetra acetate (EDTA)	526	711			
α -eudesmol (8.154)	292	294	298		
β -eudesmol (8.153)	292	294			
γ -eudesmol (8.155)	292	294			
European Brewery Convention (EBC)	8	22	23	85	178
EBC colour units	696				
EBC tall tube	499				
haze	698	699	701		
European-style beers	6				
evaporation	4	326	331		
evaporation rate	310	331			
EWB <i>see</i> external wort heaters					
excess specific gravity	22				
excise tax	9	665	760	812	
exocytosis	381				
experimental brewhouses	654				

<u>Index terms</u>	<u>Links</u>			
explosions, dust	173			
exponential growth phase	474	476		
external expert sensory panel	735			
external tube-and-shell wort heaters (calandria heaters)	338	339		
external wort heaters (EWH)	331	338		
extract	7	22	85	660
mashing time and temperature	107	109		
recovery	199	225		
SG and extract table	838			
total extract (TE)	109			
<i>see also</i> cold water extract; hot water extract				
extract yield	116			
extractor tube	793			
 F				
f.-c. conc.-extract difference	22			
F-ratio <i>see</i> Fisher ratio				
facilitated diffusive transporters	412			
facultative anaerobes	434			
FAD <i>see</i> flavin adenine dinucleotide				
falling film evaporator	584			
false bottoms	195	197	204	
FAN <i>see</i> free amino nitrogen				
fantail pipe	528			
<i>Farbebier</i>	11	45		
β -farnesene (8.106)	286	289		
farnesol	289			
farnesyl pyrophosphate (8.105)	266	286	289	
FAS <i>see</i> fatty acid synthase				
Δ -9-fatty acid desaturase	444			
fatty acid synthase (FAS)	443			
fatty acids	161			
and beer flavour	454			

Index terms**Links**fatty acids (*Continued*)

free fatty acids	151	153			
maturation	547				
methyl esters	501				
short chain	455				
unsaturated	358	402	441	443	444
	730				
uptake by yeast	416				
yeast metabolism	443				
fed-batch yeast cultures	490				
fenpropathrin (7.5)	241				
fenpropimorph (7.16)	242				
Fenton reaction	729				
fermentability of wort	24	86	88	117	122
	134	510			
fermentable-growth-medium induced pathway	438				
fermentable sugars (FS)	108	122			
fermentation	5	364	401		
African beers	592				
changes during	402	403			
continuous	221	469	494	532	
effects of process variables on fermentation					
performance	478				
flavour metabolites	454				
and head retention	709				
heat output	512				
lipid metabolism	442				
nitrogen metabolism	449				
nutrient uptake	411				
overview	404				
restriction and low-alcohol beers	584				
role of oxygen	402	440			
secondary	5	543	544	805	807
	824				

Index terms**Links**

fermentation (<i>Continued</i>)					
sugar metabolism	418				
time course of	511				
transport of products of	418				
yeast nutrition	406				
yeast stress responses	453				
fermentation technologies	509				
basic principles	510				
bottom fermentation systems	509	514			
continuous fermentation	532				
fermentation control systems	539				
top fermentation systems	509	510	526		
fermentative sugar catabolism	428				
fermenter cooling load	513				
fermenting rooms	527				
ferric chloride	58				
ferrous ions	729				
fertilizers	231				
ferulic acid (4.131)	140	142	157	158	620
	627	682			
feruloyl esterase	142				
FG <i>see</i> final gravity					
ficin	49				
filiform papillae	717				
filler rates	760				
filling					
bottles	762	772			
cans	789				
casks	808				
kegs	797				
filling tubes	773				
film boiling	329				
filter aid	72				

Index terms**Links**

filter press	529				
filter sheets	576	771			
filtration	544				
beer	574				
membrane filtration	611	635	771		
removal of yeast and beer recovery	571				
sterile	6	60	697	770	771
	779				
water treatment	58	63			
wort clarification	223	350	355	358	
final gravity (FG)	5	511			
final temperature	194				
fine-coarse (f.-c.) extract difference	22	98			
finely ground grists	95				
finger millet	591	594			
finings	5	322	327	377	567
	710	807			
first wort	198				
Fisher ratio (F-ratio)	756				
fission yeasts	386				
five-roll mills	180	182			
fixed costs	660				
flagging	768				
flaked grains/grists	36	37	38		
flash pasteurization	602	770	782	794	
flat-bed steepers	20				
‘flat’ beer	602				
flat-sided coppers	334	336			
flavanoids	555				
flavanols	158	322			
flavin adenine dinucleotide (FAD) (4.94)	149	152	425		
flavin mononucleotide (FMN) (4.93)	149	152			
flavonoid analyses	303				

<u>Index terms</u>	<u>Links</u>				
flavonoids	277				
flavonols	322				
flavour	5	32	155	512	716
changes in maturation	544				
adjustments	550				
important changes	545				
flavour chemistry of beer	727				
mashing and	164				
minor products of yeast metabolism	454				
off-flavours <i>see</i> off-flavours					
reference standards	747	752			
sensory analysis	733				
stability	723				
taste and odour	717				
terminology system	742	746	753		
flavour dilution value (FD)	297				
flavour intensity scales	742				
flavour units (FU)	285	721	727		
flavour wheel	752	753			
Flo 1 phenotype	378	379			
FLO genes	379				
flocculating agents	57				
flocculation	377	500	567	568	
flocculence	377	484	529		
flocculence phenotypes	378	379			
flocculent strains	372				
floor malting	21				
flotation	58	75	358		
flour, wheat	35	102			
flow cytometry	504	506			
flow rate					
beer lines	824				
wort	122	222			

Index terms**Links**

fluazifop-p-butyl (7.20)	243			
fluid mosaic model	380			
fluidised bed reactors	78			
fluoride ions	68			
FMN <i>see</i> flavin mononucleotide				
foam characteristics	703			
methods of assessing	704			
foam flashing method	707			
foam head	528			
foam quality	703	830		
foam stability	569	704	823	831
foam value units (FVU)	707			
foaming potential	558			
foliate papillae	717			
folic acid (4.89)	149	151	152	
food hygiene regulations	820			
forced ageing	274			
forced choice modification of the ascending methods of limits test	738			
‘forced choice’ technique	736			
forced wort flow	337			
formaldehyde	29	161	594	711
formazin	698	699		
formol-nitrogen	24	88		
2-formylfuran <i>see</i> furfural				
2-formyl-5-methylpyrrole (9.23)	314	691		
2-formyl-5-methylthiophene (9.24)	313	314	690	
2-formylpyrrole (9.18)	314	691		
2-formylthiophene (9.19)	314	690		
fosetyl aluminium (7.9)	242	244		
fouling	329	340		
four-roll mills	179	181		

<u>Index terms</u>	<u>Links</u>				
Fourier transform infra-red spectroscopy	501				
Fourier's law	329	521			
fractionation, grist	96				
free amino nitrogen (FAN)	24	88	145	457	595
	685				
free diffusion	411				
free fatty acids	151	153			
free flow system	822				
free nerve endings	717				
freeze-drying	485				
Friabilimeter	25				
Friedman's F	744				
fructans	125	136			
fructose (4.2)	108	122	124	134	413
	670	671			
fructose 2,6-biphosphate (F2 6bP)	421				
fruit-flavoured beers	7				
FS <i>see</i> fermentable sugars					
FU <i>see</i> flavour units					
Fuggles hops	230	248			
full bottle inspection	767				
fulvic acid	54				
fumaric acid (4.148)	161	162	674		
fundamental exponential growth equation	476				
fungal α -amylase	45	46			
fungicides	242	244			
fungiform papillae	717	718			
furaneol (9.12, R=CH ₃)	313	317			
furans	292				
furfural (9.8 R=H 9.17)	313	314	683	690	
furfuryl alcohol (9.20)	313	314	690		
furfuryl mercaptan (9.29)	313	314			

Index terms**Links**

furoic acid (9.28)	314				
<i>Fusarium</i> spp.	26	711			
fusel alcohols	459				
fusel oil	681				
FVU <i>see</i> foam value units					
G					
G protein	389				
G ₀ phase	386	475			
galactose (4.9)	109	124	125	137	670
gallic acid (4.125)	157	158	301	675	
galocatechin (4.140)	158	159			
gallotannins	327	557			
GAP <i>see</i> general amino acid permease					
gas 'break out'	822	824			
gas chromatography	501	667			
gas chromatography mass spectrometry (GC-MS)	501	662			
gas chromatography olfactometry (GC-O)	297				
gas exchange membranes	64				
gas lift draft tube bioreactor	537				
gas pressure regulators	562				
gas sparging	344				
gas stripping	64				
gas supply	628				
gas washing	564				
gases, solubility of	359	844			
Gay-Lussac, Joseph	364				
Gay-Lussac's equation	669				
GC <i>see</i> germinative capacity					
GC-MS <i>see</i> gas chromatography mass spectrometry					
GC-O <i>see</i> gas chromatography olfactometry					
GDC <i>see</i> granulated derivatized cellulose					

<u>Index terms</u>	<u>Links</u>			
gel chromatography	670			
gel filtration	686			
gel-proteins	121	146		
gelatin	495			
gelatinization temperature	35	38		
gene chips (DNA microarrays or DNA chips)	393			
general amino acid control	452			
general amino acid permease (GAP)	415			
general-purpose media	499	629	630	
genetic complementation studies	391			
genetic fingerprints	391	502		
genetic instability	483			
genetic modification	587			
genetics, yeast	389			
genetic analysis	390			
strain improvement	395			
genome, yeast	393			
genus	366			
geranial (8.91)	287	288	291	
geranic acid (8.92 and 8.95 , R=H)	287	288		
geraniol (8.90 , R=H)	287	288		
geranyl acetate	288	290		
geranyl isobutyrate	288	290		
geranyl propionate	288	290		
geranyl pyrophosphate (8.88)	266	286	287	288
3'-geranylchalconaringenin (8.61)	277	278	279	286
8-geranylnaringenin (8.68)	278	279	286	
germacrene B (8.112)	286	289		
germacrene D (8.113)	286	289	290	
German beer types	7			
Germany	651			
<i>Reinheitsgebot</i>	2	363	651	

<u>Index terms</u>	<u>Links</u>				
germination	1	15	21	594	
germination and kilning vessel (GKV)	21				
germinative capacity (GC)	14				
giant colony technique	497	498	499		
gibberellic acid	16	17	21	26	
gibberellin hormones	16				
Gilliland method	501				
GKV <i>see</i> germination and kilning vessel					
glass beads	496				
glass bottles	786				
glass discs, for colour	695				
glass washing machine	827				
glasses	734				
branded	830				
toughened	831				
global brands	654	655			
globulins	142				
globulol (8.134)	291	292			
β -glucan solubilase	139				
β -glucanases	25	48	102	139	140
glucans	374	375			
β -glucans	24	48	102	137	670
	702	707			
glucoamylase <i>see</i> amyloglucosidase					
glucokinase	418				
gluconeogenesis	430	431			
gluconic acid (4.155)	161	162			
glucose (4.1)	108	122	124	130	133
	134	137	413	670	671
catabolite inactivation	430	435			
catabolite repression	428	435	475		
glucose oxidase	49				
glucose-rich syrups	43	437			

<u>Index terms</u>	<u>Links</u>				
α -glucosidase	132	133	595		
β -glucosidases	139				
<i>Glucunobacter</i>	617	618			
glutamate dehydrogenase	451				
glutamate synthase (GOGAT)	451				
glutamate synthetase	451				
glutamic acid (4.33)	144	145	450	451	687
	725				
glutamine (4.34)	144	145	450	452	
glutelins	142				
glyceraldehyde 3-phosphate pathway	265				
glycerol	405	408	672	702	
glycerophospholipids	446				
glycine (4.35)	144	146	450	687	
glycogen	375	380	430	447	475
	477	505			
glycogen synthase	433				
glycolipids	154	155			
glycolysis	418	430			
β -glycosides	165				
glycosyl transferase	48				
glyoxylate cycle	430	431			
glyoxysomes	382				
GOGAT <i>see</i> glutamate synthase					
Goldings hops	248				
Golgi body	381				
grading, hops	236				
grain	11				
cleaning	20				
drying	19				
intake	19				
storage	20				
<i>see also under individual cereals</i>					

<u>Index terms</u>	<u>Links</u>				
grain discharge	206	208	209	214	
Gram negative bacteria	614	614			
Gram positive bacteria	613	614	621		
Gram stain	613				
gramine (4.81)	148	150			
granulated derivatized cellulose (GDC)	496				
gravity-assisted flow	652				
green beer	5	543			
green hops	234				
green malt	2	27	99	102	
gripper heads	763				
grist cases	187				
grists	2	11	171		
altering mashing conditions	95				
intake, handling and storage	171				
milling <i>see</i> milling					
<i>see also</i> adjuncts; malts and malting					
grits	3	36	37	39	175
refined grits	42	603			
grounds	529				
group translocation systems	412				
growth factors	410				
growth rate, yeast	493				
growth-related exothermy	612				
guanine (4.57)	146	147	689		
5'-guanosine monophosphate	725				
gueuze beers	5	7	724		
gum arabic	29				
gums	136				
α -gurjunene (8.129)	287	291			
gushing	26	100	608	710	

Index terms**Links****H**

Haber-Weiss reaction	729				
HACCP <i>see</i> hazard analysis and critical control points					
haem	441				
haemocytometer counting chamber	470	502			
half-life of foam	704				
hammer mills	183				
hand evaluation	236				
Hansen, Emil	365				
happoshu (sparkling drinks)	656				
hard resins	256	277			
hardness, water	53	60	115	845	
<i>Hauptteig</i>	209				
Hayflick limit	482				
hazard analysis and critical control points (HACCP)	632				
haze	6	161	301	543	555
	607	697			
combined treatments	561				
formation	555	699			
from other than protein or polyphenol	561				
measurement of	698				
practical methods for stability improvement	702				
prediction of and beer stability	700				
removal of polyphenols	559				
removal of protein	143	556	561		
haze units	698	699			
HCN <i>see</i> hydrocyanic acid					
head retention	703	830			
beer components influencing	707				
and the brewing process	709				
headspace air	732				
headspace analysis	681	684	756		
headspace gas chromatography	694				

<u>Index terms</u>	<u>Links</u>				
heat	5				
of hydration	118	193			
output in fermentation	512				
heat exchangers	17	306			
heat flux	330				
heat recovery	8	17	71	203	345
heat shock	433	434			
heat shock proteins (hsps)	453				
heat shock transcription factor hsf1 P	454				
heat transfer	521				
heat transfer coefficient	330	521	523		
heating zones	333				
Helles malts	27				
Helm, E.	705				
Helm haze scale	698	699			
Helms method for flocculation	500				
hemicelluloses	136				
Henry's law	562				
herbicides	231	243			
heterocyclic compounds	313	314	319	320	689
	690				
heterofermentative strains	623	624	625		
heterogeneous condensation	703				
heterogeneous fermentation	515	533			
heterothallic strains	388				
hexadecanoic acid <i>see</i> palmitic acid					
hexadec-9-enoic acid <i>see</i> palmitoleic acid					
hexahydroiso- α -acids (8.50)	275	276			
hexane	238				
hexokinases	418				
hexose carriers	413				
hexose monophosphate pathway	421	624			

Index terms**Links**

HG brewing <i>see</i> high gravity brewing					
high affinity hexose carriers	413				
high-alpha hops	229	249			
high-efficiency copper	334	335			
high gravity (HG) brewing	9	117	328	439	481
	520	544	551	582	
‘high load’ systems	75				
high osmolarity glycerol (HOG) pathway	408	454			
high precision liquid chromatography (HPLC)	269	662			
high-pressure (HP) mash filter	216				
high-temperature wort boiling system	343	344			
higher alcohols	459	461	676	681	
histamine (4.69)	148	150	691		
histidine (4.36)	144	148	450	687	
histograms	743				
HMF <i>see</i> 5-hydroxymethylfurfural					
HMG-CoA reductase	448				
HMG genes	448				
HMV <i>see</i> hop mosaic virus					
HOG pathway <i>see</i> high osmolarity glycerol (HOG) pathway					
Hollandaer and Dalla Vale device	635				
holocellulose	113	136			
home brewing (African beer)	592	600	603		
homofermentative strains	623	624	625		
homogeneous condensation	703				
homogeneous systems	533				
homoserine (4.159)	165				
homothallic strains	388				
honey	40				
hop aroma units	299				
hop back	306	350			

Index terms**Links**

hop boil <i>see</i> wort boiling					
hop ether (8.159)	295	298			
hop extracts	238				
hop jack (Montejus)	349				
hop latent viroid	248				
hop mosaic virus (HMV)	247				
hop oil	227	232	239	283	551
	809				
analyses	302				
constituents in beer	298				
hydrocarbons	286				
most potent odorants	297				
oxygen-containing components	288				
post fermentation aroma products	300				
sulphur-containing compounds	295				
hop pellets	236	280	342	809	
hop-picking machines	232				
hop resins	227	232	256	673	
analysis	267				
biosynthesis	265				
hard resins and prenylflavonoids	277				
isomerization of the α -acids	269				
oxidation	280	284			
hop separators	350	351			
hop storage index (HSI)	268	280			
hop stunt viroid	248				
hop utilization	271				
hop varieties	248				
chemical identification	302				
hop wax	255				
hopped wort	4	307	308		
hoppy aroma	292				

<u>Index terms</u>	<u>Links</u>				
hops	4	227	306	607	
addition to coppers	341				
botany	228				
chemical identification of cultivars	302				
chemistry of constituents	255				
cultivation	228	230			
drying	234				
global production	227	228			
oil <i>see</i> hop oil					
pests and diseases	236	240			
picking	230	232			
polyphenols	301				
products	236				
resins <i>see</i> hop resins					
varieties	248				
<i>hor</i> A	624				
hordein-derived fragments	707				
hordeins	142	686	700		
hordenine (4.83)	148	150	157		
horizontal brewery layout	653				
horizontal leaf filter	579				
hot break	4	71	309	310	322
	326	349	354		
hot water extract (HWE or E)	22	86	98	660	841
hot water systems	329				
Hough method	500				
HP mash filter <i>see</i> high-pressure mash filter					
HPLC <i>see</i> high precision liquid chromatography					
HSI <i>see</i> hop storage index					
hsps <i>see</i> heat shock proteins					
hue	696				
hulupinic acid (8.86)	281	284			
hulupone (8.85a)	257				

<u>Index terms</u>	<u>Links</u>				
hulupones (8.85)	257	284	724		
humic acid	54				
humuladienone (8.148)	292	293			
humulene (8.111)	286	289	292	293	295
humulene/caryophyllene ratio	302				
humulene diepoxide A (8.142)	292	293			
humulene diepoxide B (8.143)	292	293			
humulene diepoxide C (8.144)	292	293			
humulene diepoxide D (8.145)	292	293			
humulene diepoxide E (8.145)	292	293			
humulene epoxide I (8.139)	292	293	295	296	299
humulene epoxide II (8.140)	292	293	295		
humulene epoxide III (8.141)	292	293	296	297	
humulenol II (8.147)	292	293			
humulinic acid (8.3a)	257	258	260	263	269
	270	271			
<i>trans</i> -humulinone (8.71)	281	282			
humulol (8.146)	292	293			
humulone (8.1a)	256	258	259	260	261
	262	263	269	273	281
humuloquinol (8.5a)	258	260			
humuloquinone (8.6a)	258	260			
<i>Humulus</i> spp.	228				
<i>see also</i> hops					
HWE <i>see</i> hot water extract					
hydration, heat of (slaking heat)	118	193			
hydrocarbons					
beer	681				
hop oil	286				
hydrochloric acid	724				
hydrocyanic acid (HCN)	149				
hydrocyclone	351				

<u>Index terms</u>	<u>Links</u>		
hydrogen	417		
constituents of beer containing	664	672	
ions	66		
hydrogen bonds	309		
hydrogen cyanide (prussic acid)	30	595	
hydrogen peroxide	730		
hydrogen sulphide	462	693	732
hydrolysis	557		
hydrolytic enzymes	16		
hydroperoxides	730		
hydroperoxydi- and triene acids (4.123)	156		
hydrophobic membranes	803		
hydrostatic pressure	482		
hydroxyacetone (9.15)	312	315	
<i>p</i> -hydroxybenzoic acid (4.124)	157	158	
<i>p</i> -hydroxybenzylamine (4.80)	148	150	691
3-hydroxy-2-butanone <i>see</i> acetoin			
4-hydroxy-3(2 <i>H</i>)-furanone (19.4)	684		
1-(3-hydroxy-2-furanyl)ethanone <i>see</i> isomaltol			
hydroxyl radical	66	729	
5-hydroxymethylfurfural (HMF) (9.8 , R=CH₂OH)	312	313	683
5-hydroxymethylthiophene (9.21)	314		
hydroxyproline (4.37)	144		
hygiene			
beer cellar	820		
cask beer	827		
hyperosmia	721		
hyperosmotic shock	408		
hypoxanthine (4.62)	146	147	
hypoxic genes	440		

Index terms**Links****I**

IBU <i>see</i> international bitterness units					
ice-bank coolers	824				
ice beers	544	582	585		
iJuba process	599				
imidacloprid (7.7)	241				
imidazoles	321				
immature beer <i>see</i> green beer					
immobilized yeast reactors	437	469	494	495	535
	546				
immunoblotting	686				
immunological analyses	500				
impact jets	525				
impact mills	182				
impedometric microbiological testing	612				
impellers	334	336	337		
IMS <i>see</i> industrial methylated spirit					
in-bottle conditioning	602				
in-line keg washing and filling machines	797	798			
in-line pasteurization	609				
inclined disc mixing vessel	192				
inclusion compounds	128				
India pale ale (IPA)	663				
indicator time test (ITT)	731				
indirect cooling	517				
individual flavour notes	735				
induced stress response	453				
inducible genes	406				
industrial methylated spirit (IMS)	523				
infusion mashing	3	88	90	102	189
	190				
initial yeast concentration	477				
inoculum	477				

<u>Index terms</u>	<u>Links</u>				
inorganic beer constituents	664	666			
inorganic ions	163				
5'-inosine monophosphate	725				
<i>myo</i> -inositol (4.91)	149	151	152	163	411
<i>meso</i> -inositol hexaphosphate <i>see</i> phytic acid					
inositol phospholipids	446				
insecticides	241				
Institute of Brewing (IoB)	8				
equivalence between units of hot water extract	841				
malt analyses	22				
Institute and Guild of Brewing (IGB)	8	655			
General Certificate in Brewing and Packaging	658				
insulation	519	554			
intake of raw materials	171				
intensity scales	742				
intensity tests	744	745			
interconversion factors					
temperature scales	835				
units of measurement	837				
internal cask washer	806				
internal heaters	334	335	336	338	
international bitterness units (IBU)	270	673			
International Code of Botanical Nomenclature	366				
intimate mixing	519				
intracellular membrane systems	381				
intracellular sterol transport system	449				
intrinsic viscosity	568				
inversion temperature	522				
invert sugar	40				
invertase	414				
iodine	128	646			
iodophores	646				
ion channels	412				

<u>Index terms</u>	<u>Links</u>				
ion chromatography	664				
ion exchange treatments	61				
β -ionone (8.164)	294				
ions	844				
effect on brewing process	65				
inorganic ions in sweet wort	163				
metal <i>see</i> metals and metal ions					
uptake by yeast	416				
IPA <i>see</i> India pale ale					
Irish moss	322	327			
iron ions	58	66	729		
<i>IRRI</i> gene	498				
irrigation	232				
isinglass finings	323	377	567	710	807
ISO 9000 quality standard	632				
iso- α -acid salts	271				
iso- α -acids (8.40)	227	256	269	376	623
	673	708	709	724	725
	731				
ρ (rho)-iso- α -acids (8.49)	275	276	708	725	
isoadhumulone (8.40c)	256	272			
isoamylase	47				
iso-butanol	459				
isobutylamine (4.66)	148	150	691		
isobutyraldehyde (8.14)	258	260	269	270	274
	721	731			
isocitrate lyase	430				
isocohumulone (8.40b)	256	272			
isohexenoic acid (8.13)	258	260	270		
isohumulinic acid (8.7a)	258	260			
isohumulone (8.40a)	256	269	270	271	724
<i>abeo</i> -isohumulones (8.77-8.83)	281	283			
<i>cis</i> -isohumulone (8.43)	256	272	273		

Index terms**Links**

isohumulone (8.40a) (<i>Continued</i>)					
reduced isohumulones	520	786			
<i>ρ</i> -isohumulone (8.49a)	276				
<i>trans</i> -isohumulone (8.44)	256	263	272	273	281
	623				
isokestose (4.21)	125	127			
isoleucine (4.38)	144	450	687		
isomaltol (9.30)	313	314			
isomaltose (4.13)	125	126	133	670	
isomerized hop extract	237	269	550	711	
isopanose (4.15)	125	126	670		
isopentenyl pyrophosphate (IPP) (8.33)	265	267	286	287	
isoprene (8.23)	264	280			
isoprene hydrobromide (8.24)	264				
isoprenoid biosynthesis	265				
2-isovaleryl-4-(3-methyl-2-butenylidene)	711				
isoxaben (7.21)	243				
isoxanthohumol (8.65)	277	278	279		
isozymes	424				
ITT <i>see</i> indicator time test					
J					
Japan	656				
Japanese two-stage process	537				
<i>cis</i> -jasnone (8.166)	294				
jump-mash system	92				
juniper camphor (8.152)	292	294			
just in time delivery	816				
K					
kaempferol (8.57)	277	278	302		
karahana ether (8.160)	295	298			
karyotyping	392	395	502		

<u>Index terms</u>	<u>Links</u>				
keg beer	759	792	820		
capping and labeling kegs	802				
determination of contents of keg	801				
dispense systems	822	825			
handling of kegs	796				
internal cleaning and filling of kegs	797				
kegs	793				
smooth flow ales	803				
treatment of beer for keging	794				
keg racker	797				
kestose (4.20)	125	127			
α -keto acids	450				
keto-enol tautomerism	261				
α -ketoglutaric acid (4.147)	161	162	674		
ketones	680	684			
kettles <i>see</i> coppers					
keystone	805	806	808		
kieselguhr filtration	577	579			
kieselguhr regeneration	72				
kieves <i>see</i> mash tuns					
killer factors	370	626			
kilning	2	16	17	21	99
	594				
kilns, hop drying	234				
Kimberley process	599				
kinematic viscosity	702				
kinesthetic sense	717				
kinetochore	383				
Kjeldahl method	685				
<i>Klebsiella</i> spp.	47	617	619	620	
Kluyver effect	435	438			
<i>Kluyveromyces</i>	627				
knives	195	206	208	209	

<u>Index terms</u>	<u>Links</u>				
kojic acid (4.154)	161	162			
Kolbach index	24				
krausening	543	545			
Krebs cycle	422				
Kubessa process	92				
Kützing, Friedrich Traugott	364				
kvass	7				
 L					
Labatt process	586				
label disposal	764				
labeling					
bottles	767				
kegs	802				
labeling machine	768				
laboratory evaluations	14				
laboratory extract	96	98			
laboratory fermentations	499				
laboratory mashes	23				
laboratory mills	178				
laboratory yeast propagation	486	488			
lacing	704				
lactic acid (4.150)	29	116	161	162	590
	599	624	674		
lactic acid bacteria	116	621			
lactic-malts	29				
<i>Lactobacillus</i>	622	623			
lactones	680	684			
lactose	40				
lag phase	474	475			
lager malts	27				
lager yeasts	369	499			

Index terms**Links**

lagers	5	7	479	754	
maturation methods	547				
lagoons	76				
lambda-cyhalothrin (7.4)	241				
Lambert's law	698				
lambic beers	5	7	370	669	724
laminaribiose (4.19)	122	125	127	139	
last runnings	72	119			
late hop essences (LHE)	301				
late hopping	285	301	348	550	
lauter tuns	3	4	89	95	175
	203				
choice of mashing and wort separation systems	217				
lautering (wort collection)	116	198	204	209	215
layering	231				
LCV <i>see</i> lead conductance value					
leaching	223				
lead	665				
lead conductance value (LCV)	268				
leaf filters (screen filters)	579	581			
least significant difference (LSD)	746				
lectins	143				
ledol (8.132)	291	292			
Leeuwenhoek, Antonie van	364				
lemma	12				
lethal effect	783				
leucine (4.39)	144	450	684	687	
LHE <i>see</i> late hope essences					
licensed premises	627	819			
beer cellars	820				
beer dispense systems	821				
history	820				
new developments in trade quality	830				

Index terms**Links**

licensed premises (<i>Continued</i>)					
quality control	830				
lichenase	670				
light absorption	268	695	696		
light beers	7	587			
lighting	821				
lignin	699				
lime-water	60				
limit dextrinase	133				
limonene (8.98)	287	289			
linalol (linalool) (8.87)	287	288	290	297	
linalol oxide (8.162)	295				
line cleaning agents	647				
line cooler units	824	825			
linear keg internal cleaning and filling machine	797	798	799		
linkage maps	390				
linoleic acid (4.112)	151	153	155	462	730
linolenic acid (4.113)	151	153	155		
Lintner scale (L)	24				
lipases	49	155			
lipid binding proteins	709				
lipid complexes	128				
lipid transfer protein 1 (LTP 1)	143	154	686	707	
lipids	324				
in beers	673	708			
granules	447	449			
lipid particles in cytoplasm	380				
in mashing	151				
membrane lipids	380				
uptake by yeast	416				
yeast metabolism	442				
<i>see also</i> fatty acids; phospholipids; sterols					
lipoamide dehydrogenase	423				

Index terms**Links**

lipophilicity	726				
lipoxidase enzymes (LOX)	156				
liquid carbon dioxide extraction	238				
liquid flow, rate of	222				
liquid malt	43				
liquid nitrogen	486				
liquid nitrogen jetting	779				
liquor/grist ratio	116				
load cells	174				
local overheating	327				
lodicules	13				
logistics	760	812	815		
low-affinity hexose carriers	414				
low-alcohol beers	7	122	497	544	582
	667				
low-anthocyanogen malts	99				
low-carbohydrate beers	7	92	122	582	586
'low load' systems	75				
low-NOx burners	17				
low-pressure boiling	342				
LOX <i>see</i> lipoxidase enzymes					
LPC <i>see</i> lysophosphatidylcholine					
LSD <i>see</i> least significant difference					
LTP 1 <i>see</i> lipid transfer protein	1				
luparone	288	290			
lupones (8.29)	264	265			
lupulin-enriched hop pellets	237				
lupulin glands	229	232	235	236	809
lupulone (8.2a)	256	258	260	261	262
	263	269			
<i>see also</i> beta-acids					
lyophilization	485				
lysine (4.40)	144	148	450	603	687

<u>Index terms</u>	<u>Links</u>				
lysophosphatidylcholine (LPC) (4.23)	128	129	153		
M					
magnesium bicarbonate	60				
magnesium ions	66	232	664	666	
magnetic separation	174				
Maillard reaction	145	311			
maize grits	36	37	38	103	
maize starch hydrolysates	41	42			
MAL genes	414				
malate-aspartate shuttle system	426	427			
malate synthase	430				
malic acid (4.152)	161	162	674		
malonyl coenzyme A (8.31)	266	267			
malt colourants	41	45			
malt extracts	41	43	327		
malt flour	587				
malt lipids	151				
malt mash	93				
maltol (9.11)	312	313	733		
maltopentaose (4.7)	122	124			
maltose (4.4)	108	122	124	130	131
	133	413	414	437	670
	671				
maltose fermenting enzymes	395				
maltose-rich syrups	43				
maltotetraose (4.6)	122	123	124	670	671
maltotriose (4.5)	108	122	123	124	125
	133	413	414	670	671
maltoxacin (9.44)	316	317			
malts and malting	1	11	608		
African beers	592	593			
blending malts	18	101			

Index terms**Links**

malts and malting (<i>Continued</i>)					
changes occurring in malting grain	14				
contaminated malt and gushing	100	608	711		
delivery of malt	18				
malt analyses	21	98			
malt specifications	32				
malting losses	17				
malting technology	19				
malts in mashing	97				
microbial infections	15	100	608		
outline of malting process	11				
proanthocyanidin free malt	560				
special malts	18	31			
storing malts	18				
types of kilned malt	26				
maltulose (4.17)	125	126			
management information system (MIS)	657	658			
manganese ions	58	66			
mannoprotein	374	375			
mannose (4.8 and 11.1)	109	124	125	137	375
	670				
manual cleaning	640				
Manual Handling Regulations	814				
manufacturing reserve planning (MRPII)	659				
MAP <i>see</i> mitogen-activated protein (MAP) kinase signal transduction cascade					
maple syrup	40				
mash	3				
mash bed depth	121				
mash cookers	3	200			
mash filters	3	4	89	95	175
	210	212	217		
mash hydrators (pre mashers)	191	193			

<u>Index terms</u>	<u>Links</u>				
mash-mixing vessels	3	89	199	202	203
mash thickness	116				
mash tun adjuncts	2	34	101	145	
mash tuns	3	95	175	189	194
	210	350			
choice of mashing and wort separation systems	217				
construction	194				
operations	198				
mashing	3	85			
altering mashing conditions	95				
adjuncts	101				
grist	95				
malts	97				
mash thickness, extract yield and wort quality	116				
mashing liquor and mash pH	113				
non-malt enzymes	110				
temperature and time	104				
wort separation and sparging	119				
and beer flavour	164				
biochemistry	122				
inorganic ions in sweet wort	163				
lipids	151				
miscellaneous acids	161				
miscellaneous substances containing nitrogen	146				
non-starch polysaccharides	136				
nucleic acids and related substances	146				
phenols	157				
proteins, peptides and amino acids	142				
starch degradation	127				
vitamins and yeast growth factors	149				
wort carbohydrates	122				
control and low-alcohol beers	584				
schedules	88	104			
spent grains <i>see</i> spent grains					

<u>Index terms</u>	<u>Links</u>				
mashing columns	23				
mashing in	2	189	190		
mashing liquor	64	113			
mashing technology	189				
lauter tuns	3	4	89	95	175
	203	217			
mash filters	3	4	89	95	175
	210	212			
mash tuns <i>see</i> mash tuns					
mashing in	190				
mashing vessels for thin mashes	199				
other methods of wort separation and mashing	220				
selection of mashing and wort separation systems	217				
spent grains	222				
Strainmaster	120	211	709		
theory of wort separation	222				
mashing vessel	193				
mass flow system	803				
mass pitching methods	520				
matching tests	735				
materials requirements planning (MRP)	659				
mating types	387	389			
maturation	5	509	543		
carbonation	6	543	562		
clarification and filtration	567				
flavour, aroma and colour adjustments	549				
flavour changes	545				
principles of secondary fermentation	544				
special beer treatments	582				
stabilization	543	555			
techniques	547				
vessels	552				
maximum allowable residue (MRL)	240				
mbweje	592				

Index terms**Links**

Mean Brewery Table	669				
MEBAK <i>see</i> Mitteleuropäischen Analysen Kommission					
mechanical vapour recompression (MVR) system	347				
medieval ale	227				
<i>Megasphaera</i>	619	621			
meiosis	387	389			
melanoidin malt	28				
melanoidins	311	319	321	695	708
melibiose	409				
membrane-bound fatty acid elongation system	445				
membrane compression filters	216	218	220		
membrane filtration	611	635	771		
membrane fluidity	445				
membrane reactor	77				
membrane-stabilizing agents	434	440			
8(9)-menthene (8.99)	288	289			
4-mercaptopentan-2-one	733				
<i>N</i> -(2-mercaptoethyl)-1,3-thiazolidine (9.49)	317				
8-mercapto- <i>p</i> -menthan-3-one (20.12)	732	733			
merissa	591				
‘Merlin’ wort boiling system	340				
mesaconic/laevulinic acid	161				
metal ion carriers	416				
metalaxyl (ridomil) (7.8)	243	244			
metallized paper	768				
metals and metal ions	440	711			
in beer	664	665	666		
metals for fermenting vessels	516				
uptake by yeast	416				
metered dispense	822	824			
methanization	79				
methional	733				

<u>Index terms</u>	<u>Links</u>				
methionine (4.41)	144	163	165	410	450
	687				
methyl 4,8-decadienoate	288	290			
methyl 4-decenoate	288	290			
methyl heptanoate	288	290			
S-methyl hexanethiolate	296				
S-methyl 2-methylbutylthioate	296				
methyl nonyl ketone	288	290			
methylamine (4.64)	148	150	691		
2-methyl-3-buten-2-ol (8.69)	280	282	459		
3-methyl-2-butenyl bromide (8.24)	264	281			
3-methyl-2-butenyl thiol (prenyl mercaptan) (8.48)	275	276	277	550	694
	732				
methylene blue stain	26	502	503	520	
2-C-methylerythrose (8.38)	265	267			
5-methylfurfural (9.22)	313	314	683	690	
4-methylimidazole (9.50)	321	550			
S-methylmethionine (SMM) (4.157)	25	99	165	319	327
	463	546	691		
4-methyl-3-pentenoic acid (8.13)	258	260			
4-(4-methylpent-3-enyl)-3,6-dihydro-1,2-thiine (8.167)	295	296			
3-(4-methylpent-3-enyl)thiophene (8.169)	295	296			
3-methylthiophene (8.168)	295	296			
3-(methylthio)propionaldehyde	733				
methyltyramine (4.82)	148	150			
Meura 2001 filter	216	218			
mevalonate pathway	265				
mevalonic acid (8.35)	265	266	267		
MI phenotype	378	379			
microbial enzymes	2	47			
microbiological control system	779				
microbiological failures	613				
microbiological media	628				

<u>Index terms</u>	<u>Links</u>			
microbiological testing				
spoilage organisms	610	615	616	
yeast identification	498			
microbiology	606			
beer spoilage organisms	610			
detection of contaminants	610			
gram negative bacteria	614	614		
gram positive bacteria	613	614	621	
identification of brewery bacteria	613	615	616	
microbiological media and cultivation of micro-organisms	628			
yeasts	625			
cleaning in the brewery	637			
disinfection of pitching yeast	636			
infections of malts	15	100	608	
quality assurance	632			
sampling	634			
threat to the brewing process	607			
micro-breweries	654	655		
microbubbles	710			
micro-colonies	502	611		
<i>Micrococcus</i>	621	622		
micronized grains	36	37	38	
MicroStar rapid microbe detection system – Sapporo special (RMDS-SPS)	613			
microtubules	383	384	386	
microvilli	717			
mild ale malts	28			
millets	11	13	30	35
malting	593			
milling	2	95	175	
conditioned dry milling	184			
dry roller milling	179			
impact mills	182			

Index terms**Links**

milling (<i>Continued</i>)			
laboratory mills	178		
principles of	175		
spray steep roller milling	184		
steep conditioning	186		
under water	187		
mineral elements	371	410	603
minimum standards for brewing waters	54	56	
MIS <i>see</i> management information system			
mist propagation	231		
mitochondria	382		
mitochondrial genome	394		
mitogen-activated protein (MAP) kinase signal			
transduction cascade	389	408	
mitosis	384		
Mitteleuropäischen Analysen Kommission (MEBAK)	8		
mixed effluent treatment systems	80		
mixed gas dispense	822	823	
‘mixed’ mashing systems	95		
MK 15/20 filter	217	220	
Mn SOD	442		
modification	1	16	596
problem malts	99		
tests for	25		
Modgen formula	69		
moisture content			
hops	255		
malt	22		
molecular distillation	239	285	
Monier-Williams distillation method	693		
Monitek 251	698		
Monod equation	476		
mono-epoxides	291		

<u>Index terms</u>	<u>Links</u>		
mono- β -D-galactosyl diglyceride (4.114)	154	155	
monoglyceride (4.103)	153	155	
monoisoprenylphloracylphenone (8.25)	264	265	266
Monopolies and Mergers Commission	815		
monoterpenes	266	286	
Montejus (hop jack)	349		
morphological changes	482		
moulds	608	711	
mouth-feel	717	734	
MRL <i>see</i> maximum allowable residue			
MRP <i>see</i> materials requirements planning			
MRPII <i>see</i> manufacturing reserve planning			
multi-dimensional scaling	752		
multi-layered kilns	235		
multi-packs	763		
multi-planar CIP head	525		
multiple carriers	412		
multivariate analysis techniques	302		
Munich malt	28		
Munich-type beers	7	663	
mutagens	390		
α -muurolene (8.117)	286	290	
γ -muurolene (8.120)	286	290	
MVR <i>see</i> mechanical vapour recompression (MVR) system			
mycobutanil (7.10)	242		
mycotoxins	100	608	
myrcene (8.89)	286	287	288
myristic acid (4.107)	151	153	155

N

NAD⁺ *see* nicotinamide adenine dinucleotide

NADH *see* nicotinamide adenine dinucleotide (reduced)

Index terms**Links**

NADPH+H ⁺	421				
naringenin (8.56)	277	278			
Nathan cylindroconical vessels	514				
'native' protein	142				
natural conditioning	6				
NDMA <i>see</i> N-nitrosodimethylamine					
near-infrared spectroscopy (NIR)	14	667			
necrotic ringspot virus (NRSV)	247				
nephelometry	471	473	698		
neral (8.94)	287	288	291	297	
nerol (8.93, R=H)	287	288			
nerolidol (8.104)	289				
nettlehead	247				
New Flo phenotype	378	379			
new product development	654				
New Zealand system	535	536			
NIBEM foam stability apparatus	705				
NIBEM-T meter	706				
nickel	665				
nicotinamide (4.90)	149	151	152		
nicotinamide adenine dinucleotide (NAD ⁺) (4.54)	146	147	148	149	404
	669				
nicotinamide adenine dinucleotide (reduced) (NADH)	404	419	424	426	427
nicotinic acid (19.6)	688				
nigerose (4.16)	125	126			
ninhydrin	685				
NIR <i>see</i> near-infrared spectroscopy					
nisin	636				
nitrates	67	231	664	667	
nitric acid	526				
nitrites	67	231			

<u>Index terms</u>	<u>Links</u>				
nitrogen	54	88	565		
beer dispense	6	708	792	803	823
catabolite repression	414	415	452	465	
coagulable	24	88			
formol-nitrogen	24	88			
free amino nitrogen	24	88	145	457	595
	685				
malt analyses	23				
nitrogenous constituents of beer	664	685			
nitrogenous constituents of wort	88	146	150	307	
permanently soluble nitrogen	24	88	105	107	
soluble nitrogen ratio	24				
sources in yeast nutrition	410				
total nitrogen content	14	23	685		
total soluble nitrogen	24	88	109	110	145
wort boiling	310				
interactions with carbohydrates	311				
yeast metabolism	449				
yeast and uptake of nitrogenous nutrients	415				
nitrogen diluents	145				
nitrosamines	149	621	690		
Nitroset system	803	804			
N-nitrosodimethylamine (NDMA) (4.85)	25	149	150	690	
nivalenol	608				
‘no difference’ technique	736				
‘noble’ aroma	292				
non-biological haze <i>see</i> haze					
non-cultivation	231				
non-enzymatic browning	311				
non-malt enzymes	110				
non-oxidizing disinfectants	647				
non-porous peg	826				
non-returnable bottles	759	763			

Index terms**Links**

non- <i>Saccharomyces</i> wild yeasts	627				
non-starch polysaccharides (NSPs)	121				
in mashing	136				
non-volatile components of beer	662				
containing carbon, hydrogen and oxygen	672	674			
nitrogenous	685	690	691		
sulphur-containing	691				
<i>trans</i> -2-nonenal	463	730			
Nooter tun (Strainmaster)	120	211	709		
North America	6				
North American malts	27				
Northern blotting	392				
Northern Brewer hops	249				
NRSV <i>see</i> necrotic ringspot virus					
NSPs <i>see</i> non-starch polysaccharides					
nucleases	146				
nucleation sites	703				
nucleic acids	146	502			
nucleosidases	146				
nucleosides	146	688	689		
nucleosomes	383				
nucleotides	146	688			
nucleus, yeast	382				
numerical data	832				
nutrient sensing	433				
nutrient uptake	411				
nutritional value of beer	602	694			
nylon	647	702			
Nylon 66	559				
O					
oar/rake, mashing	189	190	191	194	195
oast houses	234				

<u>Index terms</u>	<u>Links</u>				
oat malts	30				
oats	11				
<i>Oberteig</i>	121	146	209		
obligate aerobes	434				
<i>Obesumbacterium</i>	617	618	621		
octadeca-9,12-dienoic acid <i>see</i> linoleic acid					
octadecanoic acid <i>see</i> stearic acid					
octadeca-9,12,15-trienoic acid <i>see</i> linolenic acid					
octadec-9-enoic acid <i>see</i> oleic acid					
Octyl-Sepharose CL-4B	707				
odour/aroma	716	717			
changes in maturation	544				
adjustments	550				
hop oil					
most potent odorants	297				
post fermentation aroma products	300				
<i>see also</i> flavour					
odour thresholds (OT)	726	727			
off-flavours	683	786			
cardboard flavour	730				
catty flavour	732				
goaty flavour	727				
phenolic flavour	620				
sunstruck flavour	276	550	694	732	786
OG <i>see</i> original gravity					
oil-rich hop extracts	550				
OLE1 gene	444				
oleic acid (octadec-9-enoic acid) (4.111)	151	153	155		
olfactory system	720				
oligosaccharides	130				
on-line bottle checks	767				
one-sided tests	736	738	741		

<u>Index terms</u>	<u>Links</u>				
opaque beers	589	598			
<i>see also</i> African beers					
open reading frames (ORFs)	394				
open square fermenting vessel	526				
open yeast culture (continuous)	492				
optical activity	261				
optima	86				
pH	114				
temperature	105	479			
order of presentation	734				
ORFs <i>see</i> open reading frames					
organ pipes	529				
organic acids	454				
in worts	161				
organic contaminants of water	54				
original extract	665				
original gravity (OG)	5	7	511	665	669
ornithine (4.73)	148	150			
orphan genes	394				
orthonasal olfaction	720				
oscillating U-tube	539				
Osme technique	297				
osmophilic yeasts	407				
osmotic pressure	407	481			
osmotolerant yeasts	370	407	408		
osulos-3-ene (9.7)	312				
otika	592				
overall heat transfer coefficient	523				
overcarbonation	710				
over-foaming <i>see</i> gushing					
overheating, local	327				
overmodified malts	26	99			

<u>Index terms</u>	<u>Links</u>				
oxalate haze	163				
oxalic acid (4.151)	116	161	162	163	674
oxaloacetate	424				
oxidation					
and beer flavour stability	729				
hop resins	280	284			
wort	327				
oxidative phosphorylation	382	425			
oxidiazon (7.22)	243				
oxiranes (epoxides)	290				
oxygen	610				
beer constituents containing	664	672			
concentration and yeast growth	479	480			
control and maturation	548				
control and packaging	761				
deoxygenation of water	63	551			
dissolved oxygen	63	360	610		
oxygen-containing components of hop oil	288				
role in yeast metabolism	402	440			
oxygen injection systems	520				
oxygen radicals	440	442	729		
oxygenation of wort	4	356	359	519	
oyokpo	592				
ozone	59				
 P					
P:O ratio	425				
Paar densitometer	665	667			
Pablo system	221				
packaging	759				
bottling	761				
canning	787				
cask beer	805				

Index terms**Links**

packaging (<i>Continued</i>)					
kegging	792				
overview of packaging operations	760				
packaging line	760				
paired comparison test	736	737			
paired preference test	736	737			
palate fullness	717				
pale ale malts	27				
pale ales	663				
pale malts	27	97			
palea	12				
palletizing	762				
palmitic acid (4.108)	151	153	155		
palmitoleic acid (4.109)	151	153	155		
panose (4.14)	125	126	670		
pantothenic acid (4.99)	151	152	411		
papain	49	557	561		
paper, label	768				
papillae	717				
paraflows <i>see</i> plate heat exchangers					
paraquat (7.17)	231	243			
partial recovery CIP systems	643				
particle aggregates	121				
particle diameter, 'average'	122	223			
Pasteur, Louis	364	510			
Pasteur effect	435	438			
pasteurization	6	60	587	602	609
	697	770	791		
flash pasteurization	602	770	782	794	
theory of	782				
tunnel pasteurization	608	782			
pasteurization units (PUs)	782	846			
Pasveer ditch	76				

<u>Index terms</u>	<u>Links</u>			
pattern recognition	302			
PCR <i>see</i> polymerase chain reaction				
PDC genes	429			
peak efficiency	8			
pearl barley	38	40		
pearl millet	594			
pectin	495			
<i>Pectinatus</i>	619	621		
<i>Pediococcus</i>	622	623	624	685
pegging (spiling)	826			
pelargonidin (4.137)	157	159		
PEN <i>see</i> polyethylene naphthalate				
penconazole (7.11)	242			
pendimethalin (7.23)	243			
pentane-2, 3-dione	456	545	684	
pentosanases	49	113		
pentosans	48	140		
pentose phosphate pathway	421	624		
pepsin	49			
peptidases	145			
peptides	142			
peracetic acid	646			
periplasm	379			
perlite filtration	578			
permanent hardness	60			
permanent hazes	161	555	556	698
permanently soluble nitrogen (PSN)	24	88	105	107
permanganate value (PV)	69			
permeases	412			
peroxidase	156			
peroxisomes	382	445		
pests, on hops	236	240		

Index terms**Links**

PET <i>see</i> polyethylene terephthalate					
petite mutants	394	483	685		
PG <i>see</i> present gravity					
PGA <i>see</i> propylene glycol alginate					
pH	708	808			
fermentation control	541				
mash/wort	23	87	113	324	327
phase diagram	238				
phenolic acid decarboxylase	627				
phenolic acids	157	322	673		
phenolic foams	519				
phenolic off-flavour (POF) gene	627				
phenolic off-flavours	620				
phenols	157	732			
phenylalanine (4.42)	144	148	450	687	
phenylethylamine (4.67)	148	150			
phlobaphenes	161				
phloracylphenone (8.22)	264	265	266	280	
phlorisobutyrophenone (8.22b)	264				
phlorisovalerophenone (8.22a)	264				
phloroglucinol (8.18)	262	263	264	302	
phloroglucinol triacetate (8.20)	262				
PHO5 gene	417				
phosphatases	146				
phosphate ions	68	232	410	417	664
	667				
phosphatidic acid (4.116)	154	155			
phosphatidic acid pathway	445				
phosphatidyl choline (4.118)	154	155	380	446	
phosphatidyl ethanolamine (4.120)	154	155	380	446	
phosphatidyl glycerol (4.117)	154	155			
phosphatidyl inositol (4.122)	149	154	155	380	

<u>Index terms</u>	<u>Links</u>			
phosphatidyl serine (4.121)	154	155	380	
phosphofructinase	420			
phosphoketolase pathway	624			
phospholipids	154	155	443	
lipid metabolism	445			
1'-phosphopantetheine	443			
phosphoprotein phosphatases	406			
phosphoric acid	526			
phosphorus	603			
phosphorylase	132	133		
phosphorylation	406	407	412	
oxidative	382	425		
phosphorylation potential	505			
phytase	163			
phytic acid (4.156)	149	163	164	603
<i>Pichia</i>	627	628		
pilot breweries	655			
Pilsen malts	27			
Pilsener beers	7	663		
pin mills	182			
α -pinene (8.101)	288	289		
β -pinene (8.102)	288	289		
pinocytosis	412			
pipecolic acid (4.43)	144			
pipework	517	641	642	
pitching (addition of yeast)	5	404	519	
disinfection of pitching yeast	636			
pitching rate and fermentation rate	479			
pitching rates	479	521		
pito	592			
pKa scale	262			
planning	816			

Index terms**Links**

plasma membrane	379	447		
plasmid-borne gene	624			
plasmids	393			
plastic bottles	786			
plastic caps	802			
plate count	471	473		
plate and frame filters	578	581		
plate heat exchangers	340	356	564	794
plating	498	502		
Plato table	85	660	838	
PLCs <i>see</i> programmable logic controllers				
pleasant taste	720			
plough bar (sweep arm)	206	208		
plug flow continuous reactors	492	494		
‘plug rinsing’	15			
plug-type sample cocks	634			
PMR <i>see</i> proton magnetic resonance spectroscopy				
pneumatic conveyors	173			
pneumatic malting	21			
pockets	235			
POF <i>see</i> phenolic off-flavour (POF) gene				
Pof+ phenotype	682			
Poiseuille’s equation	122	223		
polishing filter	575			
polishing treatments	82			
polyacrylamide	495			
polyethylene naphthalate (PEN)	787			
polyethylene terephthalate (PET)	786			
polymerase chain reaction (PCR)	392	502		
polymorphism	395			
polymyxin B	636			
polypeptides	685	707		

<u>Index terms</u>	<u>Links</u>				
polyphenols (tannins)	161	595	673	695	
haze formation	555	699	701		
removal	559				
hops	301				
interactions with proteins	322	700	701		
protein-polyphenol complexes	555	699			
polyphosphate	381				
polyploidy	372	395			
polysaccharide gels	121				
polysomes	381				
polysulphides	296				
polythene	647				
polyurethane foams	519				
polyvinylpyrrolidone (PVPP)	161	559	561	702	771
population equivalents	70				
porous peg	826				
positive displacement meter	822	824			
post fermentation aroma products	300				
posthumulone (8.1d)	259				
potassium bromate	17				
potassium chloride	723				
potassium ions	66	417	664	666	
powder filtration	576				
powdery mildew	245				
powdery yeasts	5	372			
precipitation	557				
precleaning	19				
precoat	578				
pre-cooked adjuncts	38				
preference tasting	734				
preference tests	744	745			
pre-germination	14				
preheating	198	337			

<u>Index terms</u>	<u>Links</u>				
prehumulone (8.1e)	259				
preliminary effluent treatments	73				
preliminary water treatments	57				
pre mashers (mash hydrators)	191	193			
prenyl bromide (8.24)	264	281			
prenyl mercaptan (8.48)	275	276	277	550	694
	732				
prenylflavonoids	277				
6-prenylnaringenin (8.66)	278	279			
8-prenylnaringenin (8.67)	278	279			
5'-prenylxanthohumol (8.62)	279				
pre-rinse stage	525	526			
present gravity (PG)	5				
pressure, dispensing	822				
pressure difference measurements	539				
pressure-lautering	211				
pressure relief valve	518				
pressure vessels	517				
pressurization					
bottling	774	776			
fermentation performance	482				
pressurized hop boiling systems	331	342	344		
primary delivery	816				
primary fermentation <i>see</i> fermentation					
primary filtration	771				
primary flavour constituents	727	728			
primary odours	721				
priming sugar	45	321	543	550	808
principal component analysis	756				
proanthocyanidins	28	29	158	322	
in beer	673				
malt free of	560				
problem malts	99				

<u>Index terms</u>	<u>Links</u>				
process department	544				
process gas sampling	635				
process variables	478				
processing of beer	5	543			
carbonation	6	543	562		
clarification and filtration	6	543	567		
maturation	544				
special treatments	582				
stabilization against non-biological haze	543	555			
procyanidin B1 (4.142)	159	160	301		
procyanidin B3 (4.143)	159	160	673		
procyanidin C-2 (8.172)	301	302			
prodelphinidin B3 (4.144)	159	160			
prodelphinidin pentamer (4.145)	158	160			
product matching	8				
product quality	716	815			
product recall procedures	817				
product traceability	770	802	814		
production capacity	658	659			
production and distribution plan	659				
proficiency testing scheme	629				
programmable logic controllers (PLCs)	657	658			
programmed cell death	483				
Project Y	365				
proline (4.44)	144	148	316	415	450
	687	688	700		
promitochondria	382	441			
PROP <i>see</i> propylthiouracil					
propagation, yeast	483				
n-propanol	459				
propylene glycol	523				
propylene glycol alginate (PGA)	710				
propylthiouracil (PROP) (20.4)	718	723			

<u>Index terms</u>	<u>Links</u>				
propyzamide (7.24)	243				
proteases	49	145			
protein dye-binding assays	686				
protein kinase cascades	389	408	433	435	454
	475				
protein kinases	406	433			
protein Z	131	143	686	707	
proteinase A	686				
proteinases	452				
protein-polyphenol complexes	555	699			
proteins	380				
in beer	685				
crude protein	63	88			
denatured	142	309			
haze formation	555	699	701		
removal	143	556	561		
heat shock proteins	453				
interactions with polyphenols	322	700	701		
in mashing	142				
‘native’ protein	142				
<i>Oberteig</i>	121				
soluble protein ratio	24				
wort boiling	309	327			
proteolysis	109				
proteolytic enzymes	49	557	702		
proteosome	433				
protocatechuic acid (4.126)	157	158			
proton antiport transport	412				
proton magnetic resonance spectroscopy (PMR)	261				
proton motive force	412	417			
proton symport transport	412				
protoplasts (sphaeroplasts)	392	396			
prussic acid (hydrogen cyanide)	30	595			

<u>Index terms</u>	<u>Links</u>				
'pseudo' hazes	698				
PSN <i>see</i> permanently soluble nitrogen					
PU <i>see</i> pasteurization units					
pub breweries	655				
pullulanase	45	47	133		
pulsations, during pre-heating	337				
pulse field electrophoresis	392				
pumps, beer	822	823			
pure cultures (yeast)	470				
purified starches	38				
purines	449	688	689		
putrescine (1,4-diaminobutane) (4.74)	148	150	691		
PV <i>see</i> permanganate value					
PVPP <i>see</i> polyvinylpolypyrrolidone					
pyrazine (9.34)	315	318	690		
pyridine (9.33)	318	690			
pyridoxin (4.100)	151	152			
pyrimidines	449	688	689		
pyrolysis gas chromatography	501				
pyrolysis mass spectrometry	501				
pyrrole (9.31)	318				
pyrroles	689	691			
pyrrolidine (4.71 and 9.36)	148	150	316	691	
1-pyrroline (9.37)	316				
pyruvaldehyde (9.13)	312	315	317		
pyruvate carboxylase	424				
pyruvate catabolism	428				
pyruvate decarboxylase	429	430			
pyruvate dehydrogenase	429				
pyruvic acid (4.146)	161	162	409	423	455
	674				
pythons	824	825	827	829	

Index terms**Links****Q**QA *see* quality assuranceQC *see* quality control

quality	716	815		
quality assurance (QA)	632	716		
distribution	817			
microbiological	632			
quality control (QC)	632	716	830	
quaternary ammonium compounds	647			
quercetin (8.58 , R=H)	277	278	302	673
‘quilted’ jacket	553	554		
quinine (20.1)	718	719	723	724

R

R-enzyme	133				
R number	524				
rachillae	12				
racking machine	808				
racking tanks	807				
radial delivery	816				
radiofrequency identification tags	802				
radiofrequency permittivity biomass meter	471	504	521	540	
<i>Rahnella</i>	617	619			
Rainier Unitank	514				
rake/oar, mashing	189	190	191	194	195
raking	209				
ranking tests	734	735	744		
rapid microbiological methods	611	614	616		
rare mating	396				
Ras cyclic AMP-dependent protein kinase signal cascade	433	435	454	475	
Rauchbier	682				
raw barley	35	102	104		

Index terms**Links**

raw materials	651	
characteristics and storage	845	
evaluation	654	
intake, handling and storage	171	
<i>see also</i> adjuncts; hops; malts and malting		
real degree of fermentation	669	
real extract	669	
recessed chamber-plate filter	215	
recirculation	198	
recognition threshold	722	
recombinant DNA technology	391	396
record keeping	760	814
recovery of beer	567	
addition of recovered beer to primary tank beer	551	571
recovery CIP systems	643	
recycling	68	787
red beers	663	
red spider mite	243	
redox-balance	405	
redox carriers	425	
reduced isohumulones	520	786
reductase activity	465	
reductones	315	731
reedbeds	82	
Reef process	597	
reference marks	770	
reference standards	742	752
reference substances (controls)	736	
refined grits	42	603
refined starches	38	
reflux	831	
refractive index method	667	
refractometry	539	

<u>Index terms</u>	<u>Links</u>		
refrigeration load	554		
regional distribution centres	658	816	
regional preferences	821		
<i>Reinheitsgebot</i> (German beer purity laws)	2	363	651
Reiter system	221		
relative light units (RLU)	613		
release parameters	817	818	
re-mashing	189	197	
remote coolers	824	825	
removal of yeast	567		
replicative age	482		
reports of sensory tests	735		
required cooling rates	513		
resin A <i>see</i> iso- α -acids			
resin B <i>see</i> 4-acetylhumulinic acid			
resins, hop <i>see</i> hop resins			
'rest' temperatures	108		
resting state G_0	386	475	
restriction fragment length polymorphism (RFLP)	392	502	
retorrification	188		
retroanal olfaction	720		
retrotransposons	394		
returnable bottles	759	762	763
washing	764		
<i>see also</i> bottling and bottles			
returned beer	72		
reverse genetic analysis	394		
reverse osmosis (RO)	62	583	
Reynolds number	794		
RFLP <i>see</i> restriction fragment length polymorphism			
rH malt	28		
ρ^0 mutants	394		

<u>Index terms</u>	<u>Links</u>			
<i>Ribes</i> (catty) flavour	732			
riboflavin (4.92)	149	151	152	695
ribonucleic acid (RNA) (4.51)	146	147		
ribose (4.12)	125	146	670	
ribosomes	380			
rice adjuncts	36	37	38	103
right to inspect	817			
rinsing	764	766		
rip-off closures	781			
RLU <i>see</i> relative light units				
RMDS-SPS <i>see</i> MicroStar rapid microbe detection system – Sapporo special				
RNA <i>see</i> ribonucleic acid				
RO <i>see</i> reverse osmosis				
road tankers	817			
roasted barleys	31			
roasting drums	18	31		
rods	621			
roll-on closures	781			
roller mills	175	177		
dry roller milling	179			
spray steep roller milling	184			
rolling boil	333			
rootlets	2	16	17	19
rope	617	624		
rose oxide (8.161)	295			
Ross and Clarke formula	704			
rotary brush strainer	351			
rotary keg internal cleaning and filling machine	797	800	801	
rotary table filter	221			
rotary vacuum filter	571	572		
rotating disc contactors	77			

Index terms**Links**

rotenone	426			
rousing	523	528		
routine microbiological testing	610			
rowing in	189			
Rudin method for head retention	705	706	830	
run-off	119			
rye	11	13	35	
rye malts	29			
S				
Saaz hop	250			
saccharification	42			
saccharification time	24			
<i>Saccharomyces bayanus</i>	367			
<i>Saccharomyces carlsbergensis</i>	369	514		
<i>Saccharomyces cerevisiae</i>	365	366	367	373 388
	407	526		
<i>Saccharomyces pastorianus</i>	367			
<i>Saccharomyces sensuo lato</i> group	367			
<i>Saccharomyces sensuo stricto</i> group	367			
<i>Saccharomyces</i> wild yeasts	626			
safety, warehouse	814			
salicylhydroxamic acid (SHAM)	428			
salivary α -amylase	591			
salt stress	407	410		
salts				
addition to mashing liquors	115			
addition to wort	327			
concentrations in brewing liquors	844			
salty taste	718	720	723	
sample cocks	634			
sampling				
hops	236			

Index terms**Links**

sampling (<i>Continued</i>)			
for microbiological testing	610	634	
sampling plan	606		
sanitation programme	780		
sanitizers	646		
sarcina sickness	624		
saturation constant	476		
SCABA <i>see</i> Servochem Automatic Beer Analyzer			
SCADA <i>see</i> supervisory control and data acquisition systems			
scalar metabolism	411		
scale of operations	8		
schedules/scheduling			
brewhouse operations	658		
mashing	88		
Schiönning, Hansen's assistant	365		
schmoos	388		
Schwann, Theodor	364		
scotches	826		
screen filters (leaf filters)	579	581	
screenings	14		
screens	179	181	184
scuffing	764	766	
SDS-PAGE <i>see</i> sodium dodecyl sulphonate – polyacrylamide gel electrophoresis			
SDU <i>see</i> sorghum diastatic unit			
seaming	790		
seasonal and special beers	663		
Seck mills	178		
secondary coolant system	524		
secondary eddies	354		

Index terms**Links**

secondary fermentation	5	543	544	805	807
	824				
<i>see also</i> maturation					
secondary flavour constituents	727	728			
secondary packaging	763				
secondary water treatments	60				
sedimentation	78	543			
removal of yeast	567				
water treatment	58				
sedimentation tanks	351	352			
seed tank	487				
seeding	831				
selective media	498	629	630		
self-cleaning clarifier centrifuge	570				
selina-3,7(11)-diene (8.115)	286	289	292		
selina-4(15),7(11)-diene (8.116)	286	289	292	294	
selina-11-en-4-ol (8.151)	292	294			
α -selinene (8.108)	286	287			
β -selinene (8.110)	286	287	292	294	
selinene/caryophyllene ratio	302				
β -selinene epoxide (8.149)	292	294			
semi-synthetic bittering agents	276	277			
senescence phase	483				
sensors	657	716			
sensory analysis	733				
sensory evaluation area	733				
sensory profile	742				
Sephadex gels	310				
sequestrants	644	645			
serial fermentation	402	483			
serine (4.45)	144	450	687		
serpins (serine protease inhibitors)	686				
Servochem Automatic Beer Analyzer (SCABA)	667				

<u>Index terms</u>	<u>Links</u>			
sesquiterpene-less oil	300			
sesquiterpenes	266	286		
sesquiterpenoids	298	299		
set mashes	120	197	198	
settleable (or suspended) solids (SS)	69	73	74	
settling distance	570			
settling tank	73			
setts	231			
sexual cycle, yeast	387			
SG <i>see</i> specific gravity				
SGV <i>see</i> steep-germination vessels				
SGKV <i>see</i> steep-germination-kilning vessels				
SHAM <i>see</i> salicylhydroxamic acid				
sheaf cells	12	13		
shear	201	349		
sheet filtration	576	577		
shelf-life	808	824		
shell room	527			
shell and tube coolers	356			
shive	805	806	809	826
shock excretion	453			
short chain fatty acids	455			
short grown malts	26			
shotgun sequencing approach	393			
SI derived units	833			
SI unit prefixes	834			
sieve analysis	175	176	177	
sieving (surface filtration)	575			
sigma value (Σ)	704			
signal transduction pathways	406	407		
silica gels	323	327	557	561 578
silica hydrogels	557	702	771	

Index terms**Links**

silica hydrosol	558		
silica xerogel	557		
silicate ions	68		
silky turbidity	624		
silos	174		
silver ions	59		
simazine (7.19)	231	243	
sinapic acid (4.132)	157	158	
single decoction mashing	91	94	
single pass filtration	575		
single-pass, two-roll dry mills	179		
single tank aeration systems	76		
single use CIP systems	643		
singlet oxygen	729		
sinker test	25		
sintered ceramic candles	520		
β -sitosterol (4.106)	153		
six-roll mills	180	182	
size exclusion chromatography	686		
skimming	526	529	
SKU <i>see</i> stock keeping units			
slack malt	173		
slaking heat (heat of hydration)	118	193	
slime	617		
slope cultures	485		
slow wort separation	113		
sludge	75		
treatments and disposal	78		
sludge bulking	75		
small-pack beer	759	760	815
SMM <i>see</i> S-methylmethionine			
smoked malt	28		

<u>Index terms</u>	<u>Links</u>				
smooth flow ales	792	794	803		
Snf1p	436				
snifiting	778	779			
SNR <i>see</i> soluble nitrogen ratio					
soaking	746				
SOD <i>see</i> superoxide dismutase					
sodium borohydride	276				
sodium bromate	17	21			
sodium dodecyl sulphonate – polyacrylamide gel electrophoresis (SDS-PAGE)	686				
sodium hydroxide	644				
sodium hypochlorite	594	646			
sodium ions	66	664	666		
soft water	53	60			
solid media	497	611	628		
solubility					
gases	359	844			
hop resin constituents	263				
soluble nitrogen ratio (SNR)	24				
soluble protein ratio	24				
solute transport processes	411				
somesthetic sense	717				
sorghum	11	13			
sorghum beers	589				
sorghum diastatic unit (SDU)	595				
sorghum grits	37	40	103		
sorghum malts	23	30	94	103	592
	593				
sour taste	718	720	723	724	
sources of extract	11				
souring	598				
Southern African beers	592				
Southern blotting	392				

Index terms**Links**

sparging	3	189	197	199	209
	223	224	350		
wort separation and	119				
sparkler	827				
special beer treatments	582				
special malts	18	31			
special mashing programmes	92				
species	366				
yeast	367				
specific gravity (SG)	5	7	85	199	665
excess	22				
fermentation control systems	539				
final gravity	5	511			
original gravity	5	7	511	665	669
present gravity	5				
tables	838				
time course of fermentation	511				
specific growth rate	476				
specifications, malt	32				
specimen answer forms	736	737	739	741	744
	745				
spectrophotometry	612				
spent grains (draff)	3	71	72	85	166
	189	199	222		
use in low-alcohol beers	585				
spent hops	71	306	326		
hot wort clarification	349				
spermidine (4.77)	148	150			
spermine (4.76)	148	150			
sphaeroplasts	392	396			
spheroconical fermenter	482				
spider mite	243				
spider web plots	743				

<u>Index terms</u>	<u>Links</u>				
spiling (pegging)	826				
spindle pole bodies	383	384			
spirit indication	669				
split cooling jackets	524				
split sour Chibuku process	599				
split treatment	61				
spoilage micro-organisms	610				
sporadic (transitory) gushing	710				
sporulation	389				
spray-balls	641				
spray steep roller milling	184				
sprinkling	14				
sprouts <i>see</i> rootlets					
squalene	442	447	448		
SS <i>see</i> suspended (or settleable) solids					
stability, beer	700				
attempts to obtain stable African beers	601				
stabilization	543	555			
stabilized hop pellets	237				
stain techniques	502	506	613		
stainless steel kegs	793				
stainless steels	516				
staling aldehydes	157				
stand	198				
standard filling	772				
'standard' malts	28				
'star' steam-heater	334	335			
starch	102				
degradation in mashing	127				
gelatinization temperature	35	38	103	128	600
granules	128	129			
purified starches	38				
starchy endosperm	12	13			

<u>Index terms</u>	<u>Links</u>				
START (critical checkpoint)	386	387	388		
stationary phase	475				
steady state	493				
steam					
distillation of hop oils	239	285			
pressure-temperature relationship for water-saturated steam	843				
steam-heated systems	200	201	329	333	
steam jacket collapse	332				
steam-jet vapour compressor	347	348			
steam-stripping	344	345			
stearic acid (4.110)	151	153	155		
steel	788				
stainless steels	516				
Steel's mashing machine	191				
steep conditioning	186				
steep-germination vessels (SGVs)	21				
steep-germination-kilning vessels (SGKVs)	20	21			
steeping	1	14	20	594	
stepwise discriminant analysis	303				
sterilants	643				
sterile filling	779				
sterile filtration	6	60	697	770	771
	779				
sterile room	780				
sterilization					
water	59	63			
wort	4	327			
sterol esters	449				
sterols	380	416	477	505	
fermentation	402	441	442	447	
sticking fermentation	125				
stillaging	826				

<u>Index terms</u>	<u>Links</u>		
stirred tank continuous fermentation	533	534	
stirrers	201	332	
stock control	813		
stock cultures	484		
stock keeping units (SKUs)	813		
stock levels	812	813	
stoichiometric sequestrants	644	645	
Stokes' law	567	569	
storage	819		
conditions	814		
hops	235		
raw materials	18	171	845
warehousing beer	812		
yeast	402		
storage carbohydrates	430		
stout	281	708	
Strainmaster (Nooter tun)	120	211	709
strains	366		
identification	499		
improvement for yeast	395		
STRE <i>see</i> stress response element			
Strecker reaction	315	319	731
stress response element (STRE)	408	454	
stress responses, yeast	453		
stringing	231		
strong ale	663		
Student's E	746		
styrene	627	682	
substrate concentration	476		
substrate level phosphorylation	420		
SUC genes	414		
succinic acid (4.149)	161	162	674

<u>Index terms</u>	<u>Links</u>				
sucrose (4.3)	40	108	122	124	125
	134	136	413	414	670
	671				
sucrose octaacetate (20.3)	718	719			
sucrose solutions	7	22	660	702	
tables	838				
sugar metabolism	418				
electron transport and oxidative phosphorylation	425				
ethanol toxicity and tolerance	438				
fermentative sugar catabolism	428				
gluconeogenesis and the glyoxylate cycle	430	431			
glycolysis	418				
hexose monophosphate pathway	421				
regulation of	434				
storage carbohydrates	430				
tricarboxylic acid cycle	422				
sugar syrups	40	608			
sugars	134	135			
adjuncts	40				
content of beers	670				
fermentable	108	122			
priming	45	321	543	550	808
relative sweetness	723				
solution divisors	842				
uptake and yeast	412				
sulphate ions	67	163	462	664	667
sulphide	462				
sulphite	462	463			
sulphur	163	410			
beer flavour and sulphur-containing compounds	462	732			
compounds and maturation	546				
constituents of beer containing	664	691			
hop oil components containing	295				
sulphur dioxide	42	551	692		

<u>Index terms</u>	<u>Links</u>				
sulphuring	235				
sunstruck flavour	276	550	694	732	786
superattenuation	626				
supercritical carbon dioxide	238				
superoxide dismutase (SOD)	442				
superoxide radical ion	729				
supertasters	718				
supervisory control and data acquisition systems (SCADA)	658				
supplementary enzymes	46				
suprathreshold effects	721				
surface binding immobilized yeast reactors	495	537			
surface filtration (sieving)	575				
surface water	53				
surfactants	644				
surplus yeast	71				
suspended (or settleable) solids (SS)	69	73	74		
sweet taste	718	719	723		
sweet wort	3				
composition	119				
sweetening	11				
synchrony	474				
syringic acid (4.128)	157	158			
syrups	40	437			
T					
T-2 toxin	608				
tank bottom beer <i>see</i> 'barm' ale					
tank bottoms	544	557	558	567	569
	571				
tank farms	517				
tanks, cleaning	641				
tannic acid	557	702			

Index terms**Links**

tanninases	49			
tannins <i>see</i> polyphenols				
tannoids	555	556		
tap	805			
tapping	826			
taste	716	717		
<i>see also</i> flavour				
taste buds	717			
taste panel	817			
taste thresholds	721			
tasting room	733			
tautomerism	261			
taxation	9	665	760	812
taxonomy, yeast	366			
TC <i>see</i> total carbohydrate				
TCA <i>see</i> tricarboxylic acid cycle				
TCD <i>see</i> tricyclodehydroisohumulone				
TDS <i>see</i> total dissolved solids				
TE <i>see</i> total extract				
telomeres	383			
temperature	761			
and carbonation	562			
cleaning and	641			
and cold break formation	358	359		
control in beer cellar	821			
control and cultivation of micro-organisms	628			
and fermentation performance	478			
influence of mashing temperature on wort quality	87	104		
inversion temperature	522			
and keg beer dispensed with carbon dioxide	822			
mashing in	193			
and pH of wort/mash	114			
sparging	119			

<u>Index terms</u>	<u>Links</u>				
temperature (<i>Continued</i>)					
steeping	14				
temperature control for fermentation systems	513	521	539		
temperature probes, position of	524				
temperature-programmed infusion mashing	4	90	93	94	108
	110	111	134	135	136
	201				
temperature scales: interconversions	835				
temporary hardness	60				
terminal threshold	722				
terminology system for flavour	742	746	753		
terpenoids	298	299			
α -terpineol (8.97)	287	289			
tertiary flavour constituents	727	728			
testa	12	13			
tetrad analysis	390				
tetrahydro- α -acids (8.9)	258				
tetrahydrodeoxyhumulone (8.8a)	258	260	276		
tetrahydrohumulone (8.9a)	258	260	275	276	
tetrahydroiso- α -acids (8.47)	275	276	550	718	724
tetraisoprenylphloracylphenone (lupone) (8.29)	264	265			
textile filters	173				
THAI <i>see</i> 2-acetyl-4-tetrahydroxybutylimidazole					
thermal vapour recompression (TVR) system	347				
thermometer scales	835				
thermophilic bacteria	307	600			
thermosyphon effect	339	340			
thiamine (4.95)	149	151	152	317	411
thiazole (9.32)	318	690			
thiazoles	317				
thioesters	296				
THMs <i>see</i> trihalomethanes					
threonine (4.46)	144	450	687		

Index terms**Links**

threshold of added substances	738			
threshold sequestrants	644	645		
thresholds, flavour	721			
throughput	829			
thymine (4.60)	146	147		
tilting	827			
time, mashing	104			
TN <i>see</i> total nitrogen content				
TOC <i>see</i> total organic carbon				
tongue	718			
tonoplast	381			
top fermentation systems	509	510	526	
Burton Union	531			
traditional systems	526			
operation	528			
vessels and rooms	526			
Yorkshire square	529			
top-pressurization	482			
top yeasts	5	377	402	
torrefied grains	36	37	38	
<i>Torulaspora</i>	627			
total acidity of beer	683			
total carbohydrate (TC)	109			
total cleaning energy	642			
total dissolved solids (TDS)	69			
total dump (total loss) CIP systems	643			
total extract (TE)	109			
total nitrogen content (TN)	14	23	685	
total organic carbon (TOC)	69			
total recovery CIP systems	643			
total resins	256			
total soft resins	256			
total soluble nitrogen (TSN)	24	88	109	110 145

Index terms**Links**

toughened glasses	831				
tower brewery lay-out	651				
tower fermenters	533				
toxic ions	54				
TPS1 <i>see</i> trehalose 6-phosphate synthase					
TPS2 <i>see</i> trehalose 6-phosphatase					
trace elements	371	410	603		
traceability	770	802	814		
trade premises <i>see</i> licensed premises					
traditional brewing	189				
traditional mash filters	212				
traditional propagators	488				
traditional top fermentation systems	526				
training, for sensory panels	734				
transaminations	450				
transformation, genetic	392				
transitory gushing	710				
transporters (permeases)	412				
treatments	5	543			
carbonation	6	543	562		
clarification and filtration	6	543	567		
maturation	544				
special beer treatments	582				
stabilization	543	555			
trehalase	432				
trehalose	389	408	414	430	440
	454	475	505		
trehalose 6-phosphatase (TPS2)	432				
trehalose 6-phosphate	414	420			
trehalose 6-phosphate synthase (TPS1)	432				
triacetylmethane (8.17)	261	263			
triacylglycerols	446				
triangular tests	726	735	736	756	

Index terms**Links**

tricarboxylic acid cycle (TCA)	422				
trichothecenes	608				
trickling bed filter	77				
tricyclodehydroisohumulone (TCD) (8.72)	281	282			
tridimefon (7.12)	242				
Trieur cylinders	20				
triforine (7.14)	242				
triglyceride (4.102)	151	153	155		
trihalomethanes (THMs)	54				
trihydroxy fatty acids	157				
tri-isoprenylphloracylphenone (β -acids) (8.28)	264				
trimethylamine (4.79)	148	150	691		
2,4,5-trimethyl-1,3-dioxolane (19.1)	672				
triple-decoction mashing	90				
tristimulus colour measurement	696				
triticale malts	30				
tropical cereal malts	30				
trub (hot break)	4	71	309	310	322
	326	349	354		
trueness-to-type tests	499				
tryptamine (4.70)	148	150			
tryptophan (4.47)	144	148	450	687	
tryptophol (19.5)	688				
TSN <i>see</i> total soluble nitrogen					
tunnel pasteurization	608	782			
turbid worts	95	120	151		
turbidity	698				
turbidometry	612				
turbulence	548				
turbulent flow	794				
TVR <i>see</i> thermal vapour recompression					
twist-off crowns	780				

Index terms**Links**

two-sided tests	736	739			
two tank brewery yeast propagation system	489	491			
two-vessel breweries	653				
two-way analysis of variance (ANOVA)	756				
tyramine (4.68)	148	150	157	689	691
tyrosine (4.48 and 8.53)	144	148	157	277	278
	450	687			
tyrosol (19.2)	672				
tyrothricin	636				
U					
UASB <i>see</i> upward-flow anaerobic sludge blanket					
ubiquinone	425				
ubiquitin system	453				
UDPG <i>see</i> uridine diphosphate glucose					
UFA <i>see</i> unsaturated fatty acids					
ullage	806				
ultraviolet light (UV)	59				
umani	720				
uncharacterized soft resins	256				
undecan-2-one	288	290			
underback	326				
underground water	53				
underletting	194	198			
undermodified malts	26	99			
unfermentable dextrins	109				
unhopped wort <i>see</i> sweet wort					
Union vessels	531				
Unitank	514				
United States (US) micro-breweries	655				
units of measurement	8				
interconversion factors	837				
unmalted cereals	709				

<u>Index terms</u>	<u>Links</u>				
unsaturated fatty acids (UFA)	358	402	441	443	444
autoxidation	730				
<i>Unterteig</i>	209				
upward-flow anaerobic sludge blanket (UASB) system	80				
uracil (4.59)	146	147	689		
urethane (ethyl carbamate) (4.87)	149	150	689	691	
uridine diphosphate glucose (UDPG) (4.55)	146	147	148	419	432
uridine triphosphate (UTP)	419	432			
UV <i>see</i> ultraviolet light					
 V					
vacuoles	381	452			
vacuum distillation	582				
vacuum evaporation	583				
vacuum relief valves	518				
validation of CIP	648				
valine (4.49)	144	148	450	684	687
vallate papillae	717	718			
valley angle	845				
valley bottom lauter tuns	204				
valve-type sample cocks	635				
valves	517				
vanillic acid (4.127)	157	158			
vapour compression	347				
vapour condensers	345				
variable costs	660				
VDK <i>see</i> vicinal diketones					
vectoral metabolism	411				
vendor managed inventory	816				
ventilation	821				
Venturi tubes/pipes	336	360	520		
vertical coolers	356				

<u>Index terms</u>	<u>Links</u>				
vertical leaf filters	579				
verticillium wilt	246	249			
vessel design	516				
vessel fittings	517				
vessel sizes	652				
viability	520				
measurement	502				
vibrating membrane filter	221	573			
vibrating screen filtration	221	355			
vicinal diketones (VDK)	429	455	456	545	684
	731				
Vienna-type beers	7				
Viennese malt	28				
vinylguaicol (4.134)	142	157	158	620	627
	681				
viridiflorene (8.126)	286	291			
viridiflorol (8.133)	291	292			
viroids	248				
virus diseases	247				
viscosity	702				
intrinsic	568				
vitality tests	504				
vitamins	149	152	603	695	
volatile organic compounds (VOCs)	57	327			
components of beer	662				
containing carbon, hydrogen and oxygen	673				
nitrogenous	689				
sulphur-containing	692	732			
control in wort	341	343	356		
volatile fatty acids	547				
volume of beer produced	659				
volumetric can filling	790	791			
volumetric pitching methods	520				

Index terms**Links**

volutin granules	381			
vortex mash mixer	191	193		
W				
walking beam	783	785		
warehousing	812			
principles of warehouse operation	813			
safety	814			
washing				
bottles	764			
kegs	796			
<i>see also</i> cleaning				
washing stages	223	224		
washout	493			
wastes	52	68		
characteristics	71			
characterization of waste water	69			
<i>see also</i> effluents				
water	2	8	52	663
adjustments and flavour	551			
bound water	118			
brewing region and	53	55		
effects of ions on brewing process	65			
effluents <i>see</i> effluents				
grades of water used in breweries	64			
hardness	53	60	115	845
mashing liquor and mash pH	113			
microbial contamination	607			
milling under water	187			
minimum standards for brewing waters	54	56		
preliminary water treatments	57			
properties	842			
secondary water treatments	60			
sources	53			

Index terms**Links**

water (<i>Continued</i>)					
steep water	15				
water activity	482				
yeast nutrition	407				
water binding	118				
water cycle	53				
water heated systems	329				
water jetting	779				
water-saturated steam	843				
water softening	62				
water-soluble hop constituents	255				
wedge wire	195	197			
wee mutants	386				
weight pitching methods	520				
Weizenbier	682	732			
wet milling	178	184			
wet trub	355				
wet weight method for yeast biomass	470	472			
wheat	11	13	29		
wheat adjuncts	35	102			
wheat beers	7	663			
wheat flour	35	102			
wheat malts	29				
whirlpools (whirlpool tanks)	4	306	340	350	352
widgets	708	792			
wild type mitochondrial phenotype ρ^+	394				
wild yeasts	606	625			
wilt	246	249			
wilt-tolerant varieties	247	249			
Windisch-Kolbach units ($^{\circ}$ W-K)	24				
wine yeasts	439				
Winge, Øjvind	365				

Index terms**Links**

wirework	230				
WLN	499				
wort	3	87			
aeration	4	356	359	519	
carbohydrates	108	122	307	308	
clarification	4	119	209	223	323
	349				
collection	198	204	209	215	
colours	23	88			
composition	87				
concentration	85				
and fermentation performance	481				
fermentability	24	86	88	117	122
	134	510			
inorganic ions in sweet wort	163				
metabolism of wort by yeast <i>see</i> yeast					
propagation medium for yeast	488				
proteins	310	311			
quality <i>see</i> wort quality					
wort boiling	4	43	306	607	709
addition of hops	341				
carbohydrate-nitrogenous interactions	311				
carbohydrates	307	308			
control of volatiles	341	343	356		
copper finings and trub formation	322				
energy conservation	345				
hot wort clarification	349				
nitrogenous constituents	307				
pressurized hop boiling systems	342				
principles	328				
protein-polyphenol interactions	322				
types of coppers	332				
wort clarification	4	119	223	323	349
wort-clarifying centrifuge	351				

Index terms**Links**

wort collection systems	198	204	209	215
wort cooling	4	344	356	
wort quality				
influences of mashing temperatures and times	104			
mash thickness, extract yield and and process	116			
	109	112		
wort recovery	71	72		
wort separation	3	90	113	119 189
	217			
choice of system	217			
slow	113			
theory of	222			
wort sterilization	4	327		
wort 'strength'	85			

X

X- α -Gal	499			
xanthine (4.63)	146	147	689	
xanthohumol (8.59)	277	279		
xerophilic yeasts	407			
xerotolerant yeasts	407	408		
xylanases	142			
xylose (4.10)	125	140	142	670

Y

yeast	5	358	363	709
addition of <i>see</i> pitching				
cask beer and yeast count	807			
cell cycle	384			
cellular composition	371			
cytology	373			
definition	367			
disinfection of pitching yeast	636			

Index terms**Links**yeast (*Continued*)

ecology	369				
genetics	389				
growth factors	149	152			
history of use in brewing	363				
metabolism of wort by yeast	401				
lipid metabolism	442				
minor products and beer flavour	454				
nitrogen metabolism	449				
nutrient uptake	411				
overview	404				
role of oxygen	402	440			
sugar metabolism	418				
yeast nutrition	406				
morphology	372				
removal of	567				
spoilage yeasts	625				
storage	402				
strain improvement	395				
taxonomy	366				
yeast stress responses	453				
yeast alcohol dehydrogenase	429				
yeast back	529				
yeast count	807				
'yeast foods'	411				
yeast genome	393				
yeast growth	402	469			
assessment of yeast physiological state	504				
batch culture	474				
phases	474				
continuous culture	492				
fed-batch cultures	490				
immobilized yeast reactors	437	469	494	495	535
	546				

Index terms**Links**

yeast growth (<i>Continued</i>)					
measurement of biomass	470				
measurement of viability	502				
on solid media	497				
yeast ageing	404	482			
yeast identification	498				
yeast propagation	483				
yeast inoculum	477				
yeast press	571	572			
yeast skimming	526	529			
Yorkshire square fermentation	529				
Z					
Z value	783				
zeta potential	377				
zinc and zinc ions	26	67	164	358	410
	417				
<i>Zygosaccharomyces</i> spp.	407	628			
zymocins	626				
<i>Zymomonas</i>	618	621			