

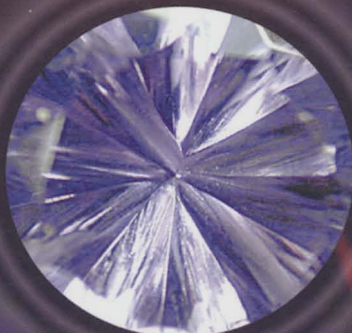

The Journal of Gemmology

Volume 28 No. 4

October 2002



Development
of concave
faceting



Verneuil
synthetic
sapphire

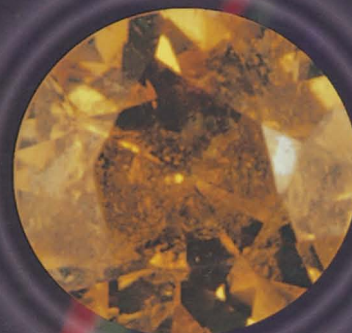

Gem-quality
spessartine-
grossular
garnet



Gemmological Association and Gem Testing Laboratory of Great Britain



27 Greville Street, London EC1N 8TN
Tel: 020 7404 3334 Fax: 020 7404 8843
e-mail: gagtl@btinternet.com Website: www.gem-a.info

President:

Professor A.T. Collins

Vice-Presidents:

N. W. Deeks, A.E. Farn, R.A. Howie, D.G. Kent, R.K. Mitchell

Honorary Fellows:

Chen Zhonghui, R.A. Howie, K. Nassau

Honorary Life Members:

H. Bank, D.J. Callaghan, E.A. Jobbins, H. Tillander

Council of Management:

T.J. Davidson, R.R. Harding, I. Mercer, J. Monnickendam,
M.J. O'Donoghue, E. Stern, I. Thomson, V.P. Watson

Members' Council:

A.J. Allnutt, S. Burgoyne, P. Dwyer-Hickey, S.A. Everitt, J. Greatwood,
B. Jackson, L. Music, J.B. Nelson, P.G. Read, P.J. Wates, C.H. Winter

Branch Chairmen:

Midlands – G.M. Green, North West – D. M. Brady, Scottish – B. Jackson,
South West – R.M. Slater

Examiners:

A.J. Allnutt, M.Sc., Ph.D., FGA, L. Bartlett, B.Sc., M.Phil., FGA, DGA,
S. Coelho, B.Sc., FGA, DGA, Prof. A.T. Collins, B.Sc., Ph.D., A.G. Good, FGA, DGA,
J. Greatwood, FGA, G.M. Howe, FGA, DGA, S. Hue Williams MA, FGA, DGA,
B. Jackson, FGA, DGA, G.H. Jones, B.Sc., Ph.D., FGA, Li Li Ping, FGA, DGA,
M. Newton, B.Sc., D.Phil., C.J.E. Oldershaw, B.Sc. (Hons), FGA, DGA,
H.L. Plumb, B.Sc., FGA, DGA, R.D. Ross, B.Sc., FGA, DGA, P.A. Sadler, B.Sc., FGA, DGA,
E. Stern, FGA, DGA, S.M. Stockmayer, B.Sc. (Hons), FGA, Prof. I. Sunagawa, D.Sc.,
M. Tilley, GG, FGA, C.M. Woodward, B.Sc., FGA, DGA

The Journal of Gemmology

Editor: Dr R.R. Harding

Assistant Editors: M.J. O'Donoghue, P.G. Read

Associate Editors: Dr C.E.S. Arps (Leiden),

G. Bosshart (Zurich), Prof. A.T. Collins (London), Dr J.W. Harris (Glasgow),
Prof. R.A. Howie (Derbyshire), Dr J.M. Ogden (Hildesheim),
Prof. A.H. Rankin (Kingston upon Thames), Dr J.E. Shigley (Carlsbad),
Prof. D.C. Smith (Paris), E. Stern (London), Prof. I. Sunagawa (Tokyo),
Dr M. Superchi (Milan), C.M. Woodward (London)

Production Editor: M.A. Burland

Development of concave faceting of gemstones

A.D. Morgan

Birmingham, West Midlands

ABSTRACT: A brief review of gem faceting methods intended to enhance the visual appearance of the stone is introduced, with illustrations of stones with various special cutting designs. Machines recently developed for producing concave facets on gem stones are illustrated and discussed. A detailed description of a machine for amateur use developed by the author is given, and the problems encountered in this method of faceting are outlined. The result of an experiment with a specially cut triangular prism having simple flat and cylindrically concave facets to compare the refracted ray patterns is shown, together with the computer-calculated theoretical ray path of a pencil of light impinging on a combination of concave lenslets and convex mirrors. Two concave faceted stones cut by the author, one in CZ and one in fluorite are featured and the patterns obtained with a Nelson Gem Fingerprinter are illustrated.

Keywords: Concave facet, faceting, gem cutting machines

193

“is it original
it was once I answered truthfully
and may be again”

don marquis, 1930

Introduction

The faceting of rough gem material to produce an optically attractive gem is a highly specialized and skilled art. Over many years, several facet designs claiming to enhance visual appearance and scintillation have been published. This is particularly so in the case of diamond, where apart from its colour and weight a considerable proportion of the value of the stone is related to the geometry and correct

placing and polishing of flat facets. This has resulted in the development of standard cuts for round brilliants and other shapes to give maximum brilliance and weight yield from the rough crystal. Further developments include the introduction of the Profile (Princess) cut by Arpad Nagy (1960), which has a series of V-grooves cut into the back of the stone, enabling flat crystals to be cut economically, and the Barion Cut by Basil and Marion Watermeyer (c. 1970).

In the case of coloured stones, whilst rarity, colour and weight are the predominant factors determining the value, the overall appearance has considerable influence on the attractiveness of the stone, and heart shaped, shield, navette, cushion, mixed cut and many other geometrical designs have appeared.

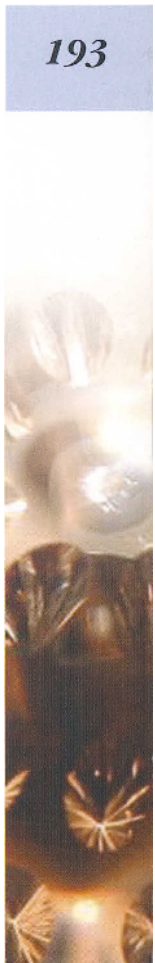



Figure 1: 42 ct (Nd) YAG 'Pinwheel' design (Ed Hume 1997) cut by Doug Morgan 1997 showing 'wheel' in the bottom of the stone.

Although there are ideal optimum cutting angles for the pavilion facets so that total internal reflection of the refracted rays will take place and give brilliance and dispersion, depending upon the refractive index of the gem material, commercial considerations often override this ideal in order that maximum yield in weight and size can be obtained. From the jewellery design aspect, often stones are cut with a shallow pavilion for mounting in finger rings. This can result in low refractive index stones having a 'fish eye' where light rays incident to the table pass straight through the stone without contributing to the brilliance and dispersion.

Cutting for special effects

Many novel effects have been produced however by deliberately cutting selected pavilion facets at angles below the critical ideal, for example the 'Pinwheel' design by Ed Hume (1997) which shows the 'wheel' as a dark pattern in the bottom of the stone (Figure 1). Other novel effects have been produced by frosting certain facets such as in the Canadian Maple Leaf Cut by Al Manastar (1999). In this some of the pavilion facets in the design of the maple leaf are frosted and so stand out from the remaining polished pavilion facets (Figure 2). This frosting technique has also been used to amusing effect as in the faces by Art Grant where a domed crown is frosted and a



Figure 2: 'Canadian Maple Leaf' design cut by Al Manastar 1999.

caricature face is polished into this background (Figure 3). Another novel effect is produced by cutting the crown as a domed hemisphere on which a pattern of small flat facets are placed, as in the 'Dandelion' cut. This was designed by the Finnish cutter Tauno Paronen, and a photograph of a stone cut by the author in quartz to the diagram⁽¹⁾ by W.J. Maloney Jr. is shown in Figure 4.



Figure 3: 'Funny face' design cut by Art Grant.



Figure 4: 'Dandelion' design by Tauno Paronen and W.J. Maloney Jr. cut by Doug Morgan 2002.



Figure 5: Early groove cut 3.33 ct amethyst.

In 1992, computer aided design (CAD) was applied to faceting by Robert W. Strickland, and his program GemCad 4.0 became available for amateur use. The program enables one to draw a gemstone pattern directly on the computer screen, it then calculates all the necessary cutting angles, shows the light ray paths and prints an expected view and brilliance factor for that particular design. A skilled user of this program can thus calculate the best cutting data for any rough material without wasting time and material. A data base (DATAVUE) of over 3500 patterns having standard flat facets is also available, and it is apparent that facet design is now on a sound mathematical foundation. The formation of lapidary societies, guilds and clubs in America, Australia and more recently in this country, has been instrumental in bringing together the large number of individual cutters with their design contributions, and there is a continual forward movement to invent and introduce new and novel facet designs, as shown in the regular contributions to the *American Lapidary Journal* and various club and guild newsletters.

In recent years considerable interest has been shown in the cutting of concave facets on gemstones as a design feature both of novelty value and to increase the attractiveness of the stone.



Figure 6: Early groove cut 35.44 ct citrine.



Figure 7: Early groove cut 17.58 ct rock crystal.

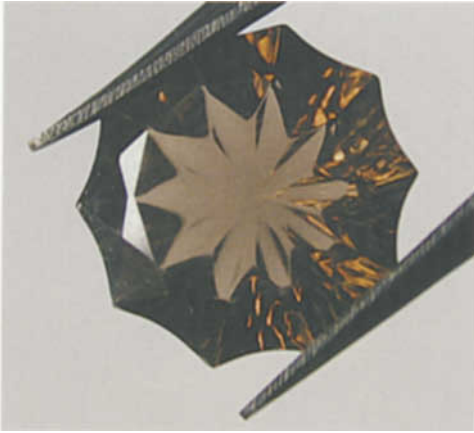

Figure 8: 7.5 ct smoky quartz 'Daisy' cut 1960 design.

Cutting of concave facets

Concave facets have been cut on diamonds, and two small triangular diamonds with spherically concave crown facets are reported in Gem Trade Laboratory Notes in *Gems & Gemology*, p.161, 1981. Nearly a century ago (1910), Jean Louis

Gonard was granted US Patent 946,939 for a method of cutting concave crown facets on diamonds "with the object of securing increased brilliancy" and a 2.68 ct old mine cut with a concave table is shown in *Gems & Gemology* Gem Trade Laboratory Notes, p.171-2, 1989. It is believed that this diamond may be related to this patent. These are said to be the only three diamonds with concave facets ever seen in the GIA Gem Trade Laboratory.

With regard to coloured fancy stones, the 'Freehand Sandstone Faceters' in the area around Idar-Oberstein over 100 years ago were producing stones with concave cut facets on the pavilion. The sandstones were over 100 cm diameter and had a 20 cm face with profiles to give concave grooves in the stones. These became quite fashionable around 1920, and later in 1950-1965, some synthetic stones were cut using metal lap wheels⁽²⁾. Typical examples of these stones are shown in *Figures 5, 6 and 7*. As freehand cut stones they represent masterpieces of the cutters art.



Figure 9: Modern groove cut 8 ct citrine.

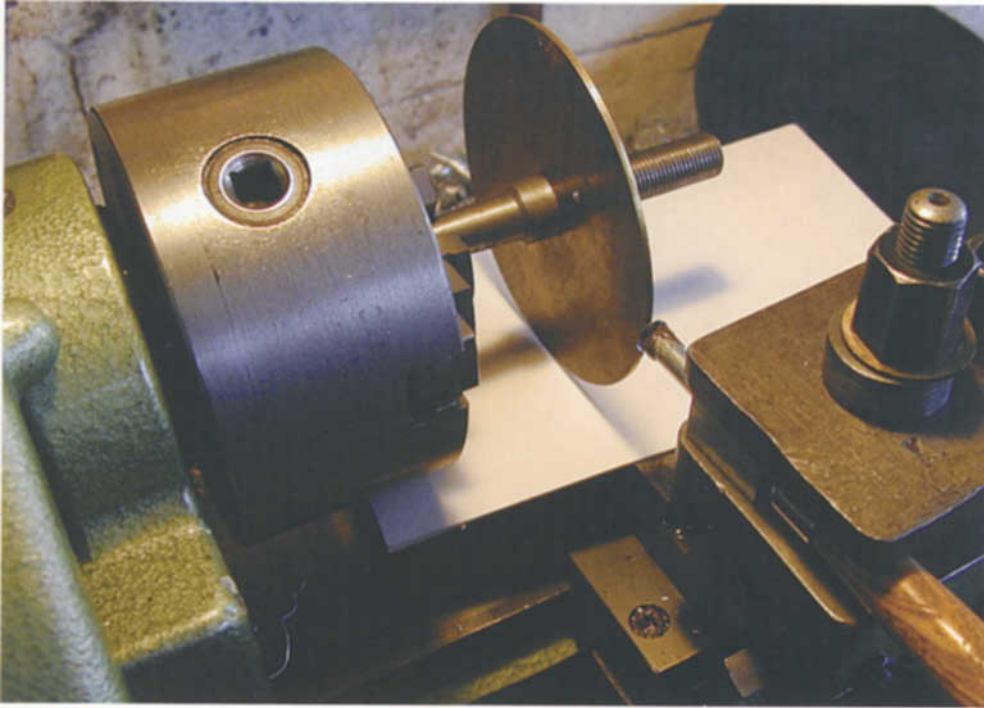

Figure 10: Lathe set-up for cutting concave table.

An attempt was made in c.1960 to introduce cylindrically concave faceted fancy stones into the British Gem Trade as 'Daisy' cut but at the time the somewhat conservative outlook deemed these unfashionable, and they also presented a design problem in mounting⁽³⁾. One of these cut from smoky quartz, having a 10-sided scalloped girdle, is shown in *Figure 8*. A modern cut stone in citrine having a pavilion with grooved facets is shown in *Figure 9*.

Practical considerations

As part of a research project the author was asked to produce a specially cut stone in (Nd)YAG with a spherically concave table facet of accurate radius of 50 mm. Traditional lens making methods were considered, but an alternative method which gave greater flexibility was developed using a normal machine shop lathe as follows.

A disc 2 mm thick in brass was machined to the required radius, and the rim profiled to the same radius of curvature, i.e. the

surface of the sphere. This was mounted on a mandrel held in the three-jaw chuck and charged with diamond grit. The stone, previously cut and polished to the required specification was mounted on the end of a spindle acting as a dop, and the spindle was mounted in a bearing clamped to the lathe tool post with its axis corresponding with the disc centre axis. The diamond charged disc was rotated at 300rpm, whilst the previously polished stone table could be applied to the disc rim via the spindle which was rotated by hand, this enabled the required spherically concave profile to be generated and ground into the surface. Subsequent use of discs having finer diamond grit, and using a tin disc charged with 1micron diamond powder for polishing gave the required result. Changes in required radius could easily be made by using discs of differing diameters. The lathe set-up is shown in *Figure 10*.

An alternative method for producing spherically concave depressions is to use a rotating sphere as a cutting lap, and this is in

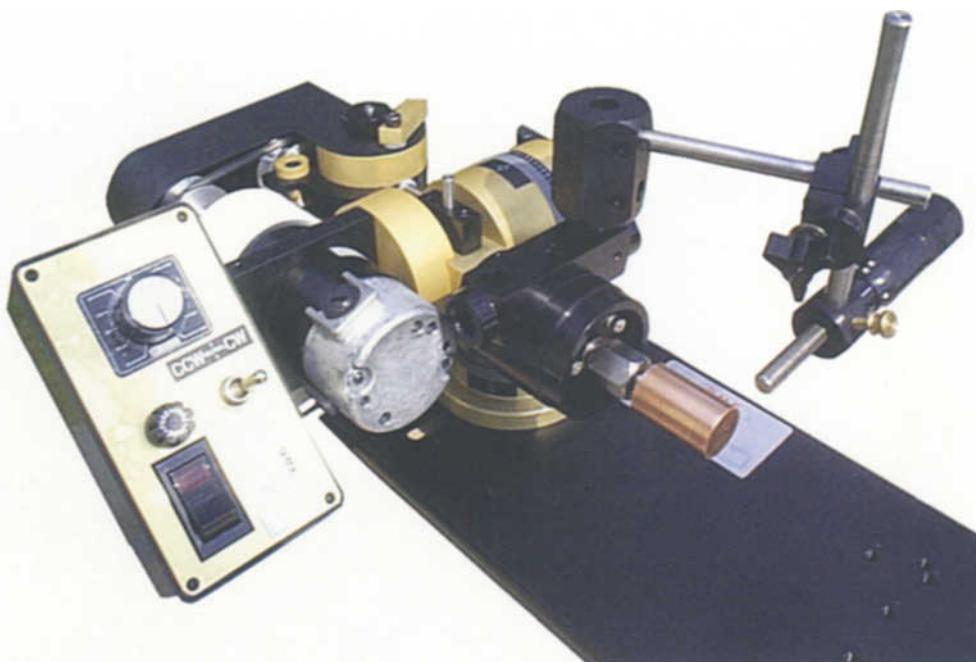

Figure 11: OMF Faceter. General view.

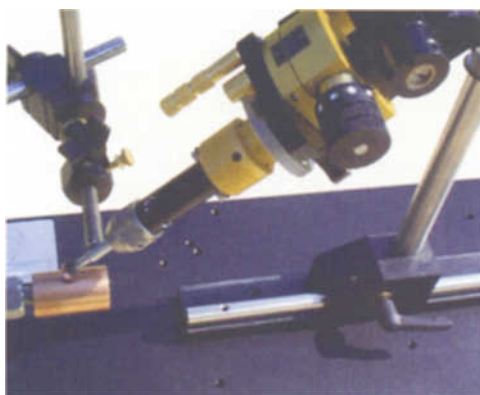

Figure 12: OMF Faceter. Detail of adjustable stop.

effect a carving ('cutting') operation such as that used by crystal glass cutters and engravers. If a series of depressions is required then some form of indexing is used.

The main development in gem cutting which is the subject of this paper however, uses a cutting lap which is a rotating cylinder charged with abrasive diamond grit, and the

gemstone held on a dop stick in a faceting head is presented to the cutting surface to give a depression of the required depth at indexed positions. A number of machines for carrying out this operation referred to as 'Concave cutting' have been developed. The operation would more strictly be classed as 'Cylindrically concave cutting'.

Cutting machines

The stones having concave pavilion facets cut in Idar Oberstein were fastened to a dop stick and held by hand against a sandstone grinding wheel. Subsequent polishing of the facet by hand took place on a lead lap wheel. No machinery having an indexing system and facet angle indication was used. The profiles on the sandstone wheels gave grooves of 15 mm and 3 mm diameter as determined by measuring a sectioned plaster cast made from a specimen gemstone. The culet and some pavilion mains angles were cut below the critical angle and showed a pattern similar to the Pinwheel cut described earlier.

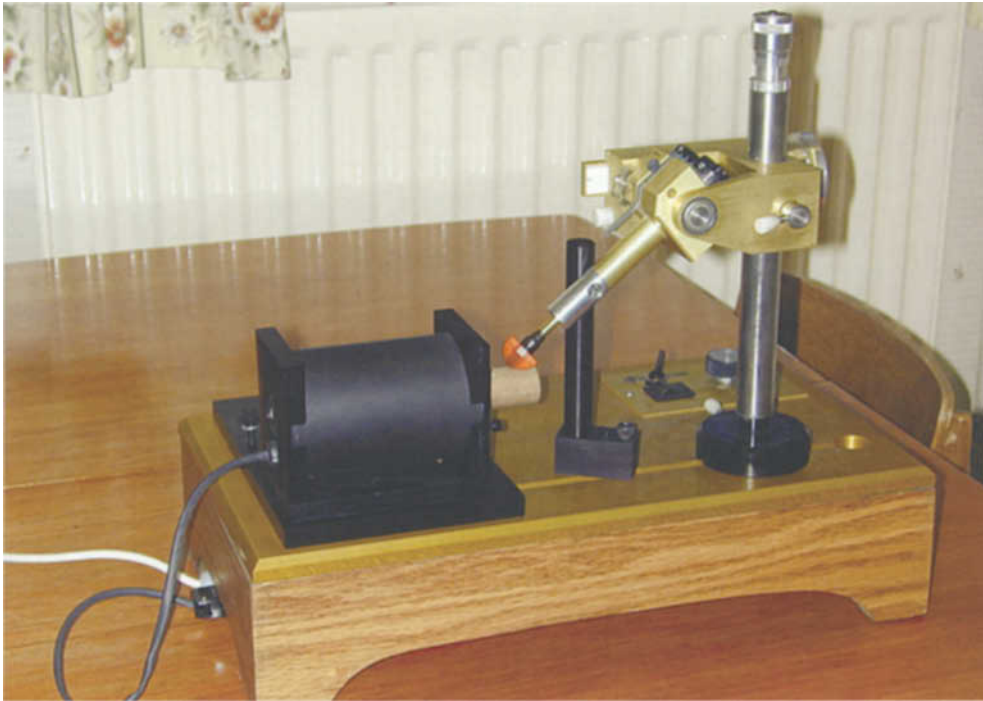

Figure 13: Facetron Special Cut Machine. General view.

The OMF Concave Faceting machine

On 3 September 1991, USA patent No. 5,044,123 filed 22 March 1990 was granted to Douglas Hoffman for a "Concave-convex faceting method and apparatus". The abstract for this patent reads as follows:

"An apparatus is described for producing concave or convex optically magnified facets about a gem, each facet being on a curved surface that is a section of a cylinder. It utilizes a mandrel having an exterior and/ or interior cylindrical abrasive surface. The surface is contacted by a gem indexed and adjustably held by a gem support structure. The mandrel is angularly moveable about its central axis. It can also be reciprocated along the axis to prevent the formation of random striations across the facet surfaces. An adjustable stabiliser can be preset to engage a dop attached to a gem at a location adjacent to the mandrel. This assures accurate reengagement of the gem after movement from the mandrel for interim inspections during the faceting procedure. The method

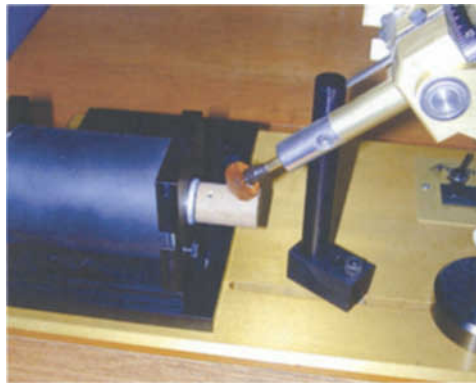

Figure 14: Facetron Special Cut Machine. Detail of dop arm hard stop post.

of producing the optically magnified facets requires successive indexing of the gem and bringing it into contact with an angularly moving cylindrical abrasive surface. The resulting gem can have one or more curved facets about its outer surface having the form of a section of a cylinder. The facet surfaces can be either concave or convex. A preselected pattern of grooved facets can be

produced across the curved facets by polishing them against a complementary moving mandrel surface."

Of particular interest is the so-called 'adjustable stabiliser' and this will be referred to later in this paper. The full specification covers every conceivable pattern of concave facets and also grooves of various axial spacings which can be cut across the previously formed concave facets.

The apparatus to which this patent refers is a faceting machine shown in *Figures 11* and *12*, marketed as the OMF Faceter manufactured by Poly-Metric Instruments, Clayton, Washington, USA. The title OMF stands for 'optically magnified facets'. Douglas Hoffmann died in 1997. A recent visit to the Internet web site <http://www.polymetricinc.com/about.html> produced by Zane Hoffmann shows the machine in detail and various accessories such as a range of cutting and polishing mandrels of 1/2 to 1 3/4 inch diameter, and costs. The basic machine costs approx. \$1500. It is of course necessary to have a suitable faceting head to go with the machine and R.P. Homer suggests using the Scintillator 88 mast type designed by Hoffmann.

Figure 15: 'Hall of Mirrors' concave cut in CZ by Chris Algar 2001.



A description of the machine and its use together with an illustration of a 6.35 ct citrine cut with the faceter in an article by Richard P. Homer was published in *Lapidary Journal*⁽⁴⁾. A recent article by Prosper⁽⁵⁾ also deals with cutting award winning stones using the O.M.F. Faceter using laps of 1/4 and 1/2 inch diameter.

The Facetron Special Cut Machine

This machine is produced by the Jarvi Tool Company, Anaheim, CA, USA, as an accessory to their well known Facetron Gem Cutting machine, although most mast type faceting heads can be used or adapted for use with the accessory. It is shown in *Figure 13* with the Facetron indexing head in position. The accessory costs approximately \$600.

In this machine the cylindrical cutter pushes on to the end of a variable speed motor spindle, and the whole unit is attached to a plate and arranged to reciprocate by means of a cam driven by a second motor beneath the plate. The plate can be turned through 90 degrees, so enabling cross cutting to be carried out like a radial arm saw, and the machine can also be used like a horizontal drill press. The accessory outfit is provided with three laps of a vee groover, a round cylinder for concave cutting, a round wheel cutter and a ball cutter.

The need for what is called the 'dop arm hard stop post', is satisfied by a pillar fastened perpendicular to the machine table, as shown in *Figure 14*, although no provision is made for micrometer movement of the stop position as in other machines.

The cutters used for cylindrical concave work are made from ABS plastic, similar to Tufnol in the UK (a fabric or paper-filled cured phenol formaldehyde resin). These are charged with 600 and 1200 grade diamond grit by coating the cutter with a layer of gel type Superglue (cyanoacrylate resin) into which is rolled the diamond grit and the glue allowed to harden. When worn, the cutter is resurfaced with steel wool abrasive, and recharged with diamond grit in a similar manner.



Figure 16: 'Pineapple' concave cut in CZ by Chris Algar 2001.

At present no-one is known to be using this machine in this country⁽⁶⁾.

The Algar Concave Faceting Machine

The only faceter in the UK who has published information and methods for producing concave faceted stones is C. Algar, who uses a machine of his own design. This



Figure 17: 'Pentanne' concave cut in CZ by Chris Algar 2001.

is not produced commercially. In an article in *Rock 'n' Gem Magazine*⁽⁷⁾ he shows several faceted gems of unique design cut in cubic zirconia. These have concave cylindrical facets, and demonstrate well the extraordinary brilliance resulting from this method of faceting, as shown in *Figures 15, 16 and 17*.

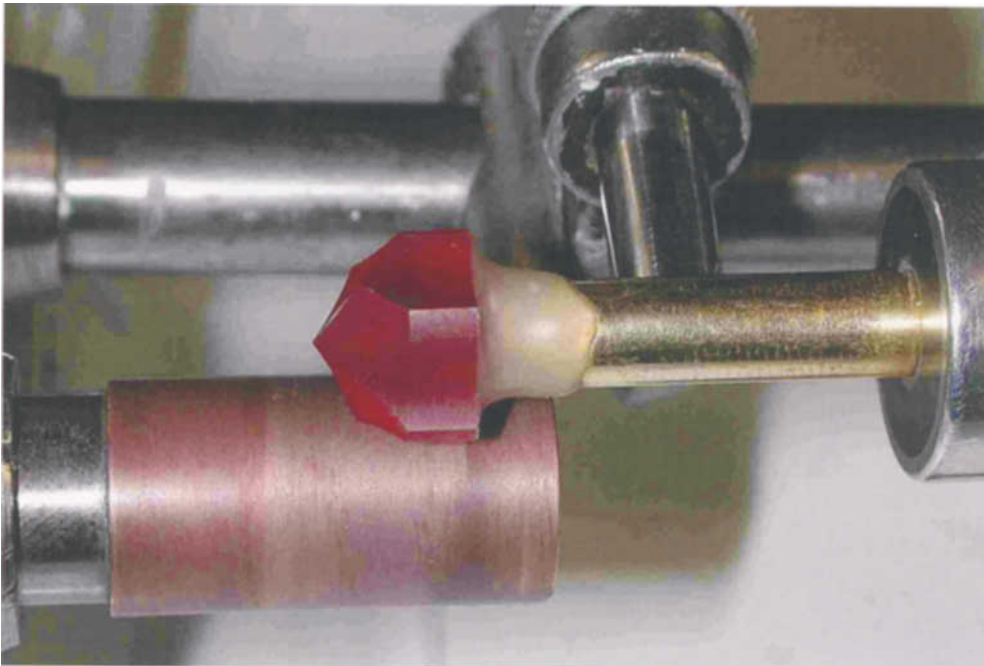

Figure 18: Stop bar with micro adjustment of Algar machine.



Figure 19: 'Son of Domet' concave cut by Chris Algar 2001.

Algar also has an Internet web page, <http://www.btinternet.com/~chrisalgar/concave.html> where details of his method and latest designs of cut stones are shown.

The Algar machine, as in the previously mentioned OMF and Facetron machines, consists essentially of a rotating and

oscillating cylindrical grinding surface to which a gemstone can be presented by an indexing dop at desired angles as in normal faceting practice. The spindle with the chuck holding the cutting cylinders revolves in a specially designed bearing and is oscillated back and forth by means of a camshaft rotating at 250 rpm against a return spring, with a linear movement of approximately 8 mm (0.3 inches).

The cylindrical laps originally used were made from lengths of standard 15 mm diameter copper water pipe fastened to a ½ inch shaft, and prepolish laps are made from cast resin/copper powder machined to the required diameter. Other lap materials are being investigated at the present time⁽⁸⁾.

The machine has a 'stop bar' with micrometer adjustment as shown in *Figure 18* to enable the axis of the dop to be accurately set in relation to the rotating lap, and to enable repeat positioning of the stone during intermittent inspection of the stone during cutting.

Recently Algar has produced stones with true spherically concave surface facets, i.e.

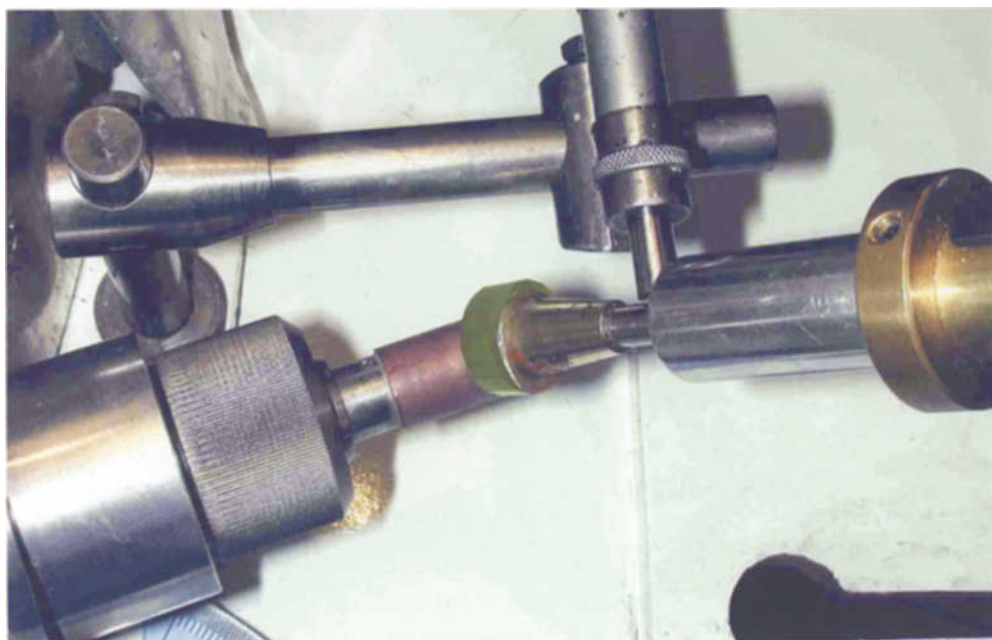

Figure 20: Dop axis inclined to lap axis in Algar machine.

negative spherical depressions placed at selected positions on a gemstone with a domed crown, as in his 'Domet's Aunty' cut, and a combination of negative spherical and cylindrical facets, as in 'Son of Domet' (Figure 19) giving a highly complex pattern of scintillation to the finished article.

Algar's machine and that of the OMF faceter have the ability to cut with the axis of the dop at an angle to the axis of the lap, as shown in Figure 20, producing even more complex cutting designs.

The Morgan faceting machine

Early design

During the latter half of 1998 the author was experimenting with a lathe as the driving spindle of cylindrical copper laps made from water pipe, and using a modified copy of the Ultra Tec machine faceting head for cutting concave facets. The normal horizontally hinged movement of the faceting head was omitted so that movement of the stone across the cylindrical lap could not take place. The whole system was attached to the saddle of the lathe and so was able to move in a direction parallel to the spindle axis and also across the lap axis.

A number of small gems were cut using this set-up, one of which is shown in Figure 21. This is an amethyst with a double row of simple flat step facets on the crown, and eight cylindrical concave facets replacing the normal mains of the (brilliant) cut pavilion. A very small culet facet at the same index as the mains was left on the pavilion. The simplicity of this design and ensuing brilliance aroused considerable interest in fellow gemmologists and a larger exhibition stone was attempted. After several unsuccessful trials it was realised that the faceting head which was located against the square mast produced by the author was not sufficiently rigid to withstand the twisting forces produced during cutting, and other means to prevent movement must be developed. At this stage, other more pressing duties caused the project to be temporarily shelved.



Figure 21: 5.6 ct amethyst with concave cut pavilion by Doug Morgan 1998.

It was not until late in 2001 that the author was introduced to Chris Algar, although he had heard of the spectacular gems being produced by this cutter, and at this time was able to inspect the machine being used and admire his exhibition of cut stones. As a result of this meeting the project was reopened, and a new approach to machine design was adopted.

Latest design of machine

The basic requirements of a machine to carry out this method of faceting can be broken down into simple items as follows:

1. A rotating spindle.
2. A chuck or collet on this spindle to hold a replaceable cylindrical cutter.
3. A means of moving the spindle back and forth by reciprocating along the axis.
4. A faceting head which can be clamped rigidly in various positions in relation to the cutter.

Bearing these requirements in mind the author considered that when constructing a prototype machine, off-the-shelf engineering products should be used where possible, thereby reducing the amount of machining needed to a minimum. Accordingly, the machine was designed around the small Peatol lathe which is readily available in the



Figure 22: Morgan concave facet machine. General view.

UK. A schematic diagram of the assembled components is shown in *Figure 22*.

Spindle

The Peatol lathe⁽⁹⁾ is produced in America and sold as an easily assembled kit of parts. It has a bed made from hardened ground steel, the remaining items being precision aluminium alloy extrusions. The headstock has sealed bearings and its spindle can be fitted with chucks or collets, so fulfilling the specified requirements.

Spindle mounting

The headstock houses the spindle in a light alloy mounting which slides along the bed in machined grooves and is normally fastened to the bed by locking screws. However, it was considered that as a loose component the situation was ideal for allowing the spindle in its mounting to be reciprocated backwards and forwards along the bed by a suitable oscillating drive, so fulfilling these requirements. The locating slides were fitted with bronze bearing strips

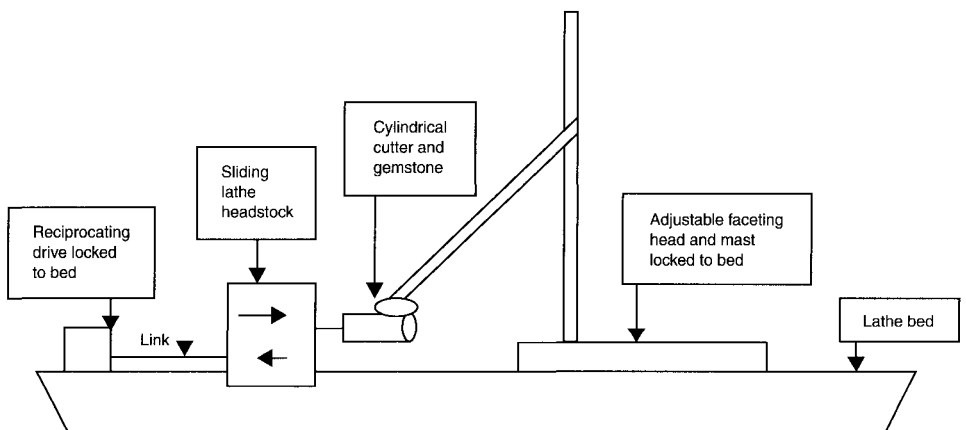

Figure 23: Schematic arrangement of Morgan concave faceting machine.

to minimise wear, and the bearing surfaces were lubricated with grease, giving a smooth sliding movement.

Oscillating mechanism

A standard type of automobile windscreen wiper drive provided a satisfactory means of obtaining a reciprocating motion and accordingly a unit was modified to fasten on to the lathe bed. The stroke was reduced to give $\frac{3}{4}$ inch movement and an adjustable link was made to attach the drive to the headstock spindle mounting, so satisfying the need for a reciprocating spindle.

Faceting head

Normal gem faceting by the author was carried out on an Ultra Tec Machine⁽¹⁰⁾ which has an indexing spindle with a tapered bore to accommodate removable tapered dop holders. The author also had a Lee⁽¹¹⁾ faceting head and mast in his possession, in which the dop holder indexing spindle unit could be removed for inspection during cutting. This had considerable advantages over a fixed dop spindle system, and so a new dop indexing spindle with a tapered bore to accommodate the Ultra Tec removable tapered dop holders was made to replace the original Lee spindle. Thus the gem stone could be faceted in the normal manner using the Ultra Tec machine to provide flat facets, and then the preformed stone still attached to the tapered dop holder was transferred to the modified Lee indexing head fixed to the concave cutting machine for concave cutting. The general layout of the machine is shown in Figure 23.

There is a considerable frictional drag experienced by the stone when in contact with the rotating lap, and rigidity in the equipment is essential to prevent unwanted movement of the stone and dop. The 'adjustable stabiliser' of the OMF machine, the 'dop arm hard stop post' of the Facetron machine, and the 'stop bar' of the Algar machine are vital components in ensuring satisfactory operation of each machine.



Figure 24: Detail of parallel bar hard stop with micro adjustment in Morgan concave facet machine.

Bearing this in mind, a new stop system for accurate positioning of the dop spindle in relation to the cylindrical cutters was developed. This essential component consisted of two parallel bars, one fixed to the movable faceting head, and the other fixed to the vertical mast spindle, as shown in Figure 24. A fine pitch screw enabled the two bars to be moved accurately in relation to one another and maintain this relationship

Figure 25: Copper cylindrical lap of Morgan concave facet machine showing 30 micron and 3 micron cutting positions (left and right on the copper cylinder).

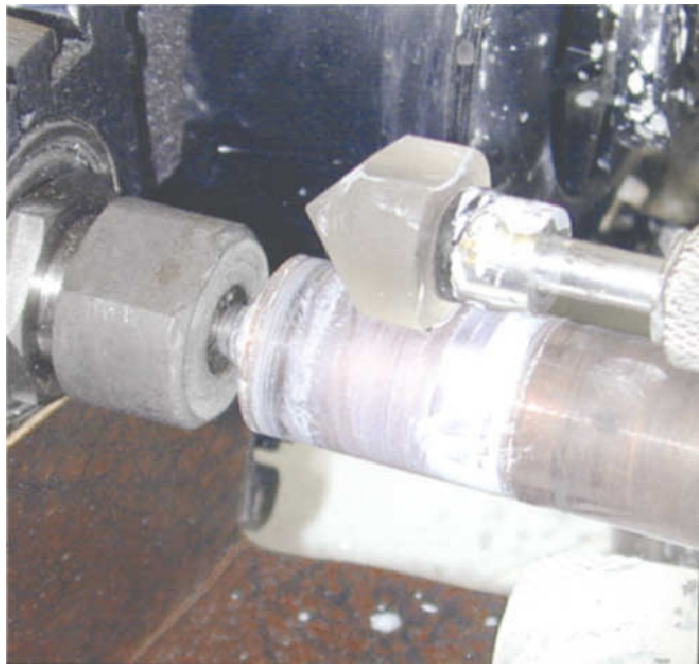



Figure 26: 59 ct CZ with concave cut by Doug Morgan 2002.



Figure 27: 18.6 ct fluorite with concave cut by Doug Morgan 2002.

as the faceting head was moved up or down the mast to give the required facet angles. This unit thus became an integral part of the faceting head itself and obviated the need to reset the stop when using the machine with the dop stick at an angle to the cylindrical cutters.

The whole faceting head and mast was fastened to a base plate by means of an adjustable clamp, and in turn this was fastened to the lathe saddle in place of the usual tool post and cross slide, so that it could be turned to any required angle on an axis situated in line with the cutter spindle axis. Since the unit was attached to the saddle, it could be traversed along the lathe bed enabling a multiple cutter with grits of different grade to be used in sequence as shown in *Figure 25*, without the necessity of stopping the machine and changing cutters. This also facilitated positioning the stone over the cutter as the facet angles were changed.

Concave cutting laps

Since there was a ready supply of domestic copper water pipe available, this was used for making cutting laps as follows. The shank of a suitable bolt was machined to fit the headstock spindle collet, leaving a portion of the thread and the bolt head so that this fitted into the copper tube. A tube

length was arbitrarily chosen to be about 30 mm long. The bolt was positioned centrally in the tube by a fixture, and cemented in place using automobile repair plastic filler. When the filler had hardened, the machined spindle was held in a lathe and the outer copper tube turned to the required diameter to produce the concave cutting lap. A set of such cutters was also made using smaller diameter tubing.

Two polishing laps were made, one from pure tin cast around a central spindle in a metal split mould and machined to match the diameters of the copper laps, and the other from heavy walled Perspex tubing machined to match the copper lap diameters.

The copper laps were charged with 30 micron and 3 micron diamond grits respectively, and the tin lap with 1 micron diamond, all used with water as lubricant applied with a brush. The Perspex lap was coated with spray-on cerium oxide polish, and was also lubricated with water.

Results using the machine

It was found that the copper laps readily cut amethyst, cubic zirconia, and fluorite. The quartz was readily polished with the Perspex lap charged with cerium oxide, and the tin lap charged with 1 micron diamond grit was satisfactory for cubic zirconia. A

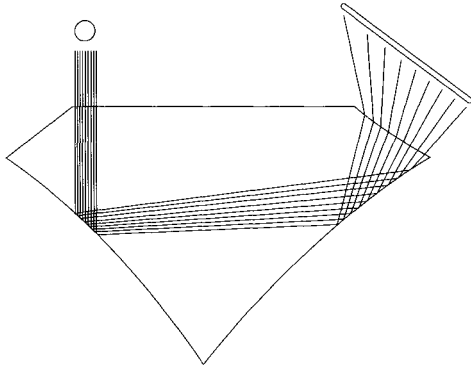

Figure 28: ZEMAX computer generated two-dimensional ray trace diagram for single concave lens and single convex mirror combination showing diversion of pencil of rays into a streak.

brilliant polish was obtained on fluorite using ½ micron diamond on tin, and it is considered that this combination would give superior results on cubic zirconia albeit a very slow polishing process.

The stone shown in *Figure 26* was cut from colourless cubic zirconia. It weighs 59.0 ct. and is 22.2 mm across the girdle points. The facet pattern was copied from the 'Pin wheel' cut by Ed Hulme previously mentioned, but has an octagonal concave cut girdle. As the finished stone was so spectacular when cut in a high refractive index material, an experimental stone cut from colourless fluorite was produced for comparison purposes with the results shown in *Figure 27*. This weighs 18.6 ct and is 16.7 mm across the girdle points. Having had much experience in cutting fluorite using a variety of facet designs, the author considers that the brilliance of this stone, whilst obviously not as great as that of the cubic zirconia, was quite remarkable for a stone of low refractive index and supports the claims of increased brilliance made for stones with concave facets.

Optical considerations

In a normally cut gemstone with flat facets, the ray path of a pencil of light

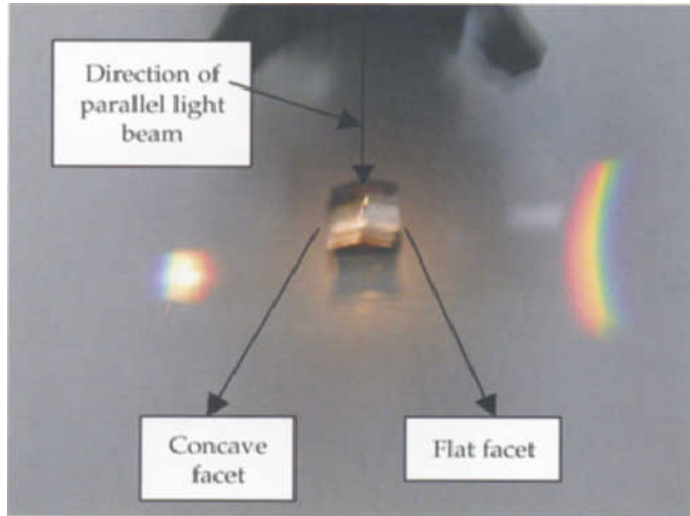

Figure 29: Nelson type dispersion image produced by CZ prism with cylindrically concave facet and flat facet.

impinging on a facet is determined by the refractive index of the stone and the angular positions of flat facets acting like plane mirrors to give total internal reflection. There is no divergence of the ray which, unless it is monochromatic, will undergo dispersion to give a spectral image.

In the case of a stone having cylindrical concave facets on the crown and pavilion, the pencil of light first passes through a concave lens, and then is totally internally reflected by a convex surface acting as a mirror, and escapes via a concave lens. Thus in a gemstone having indexed facet positions the pencil of rays is subjected to a highly complex system of concave lenslets and convex mirrors. Both the concave lens and the convex mirror surface cause divergence of the pencil of light, as is shown by the theoretical ray trace diagram in *Figure 28* produced by computer program ZEMAX V.6⁽¹²⁾ for a gem-shaped transparent medium of R.I ~ 2.0. The concave and convex cylinders transform the pencil from a spot to a streak.

This divergence of the ray by a concave cut facet to form an elongated image can be

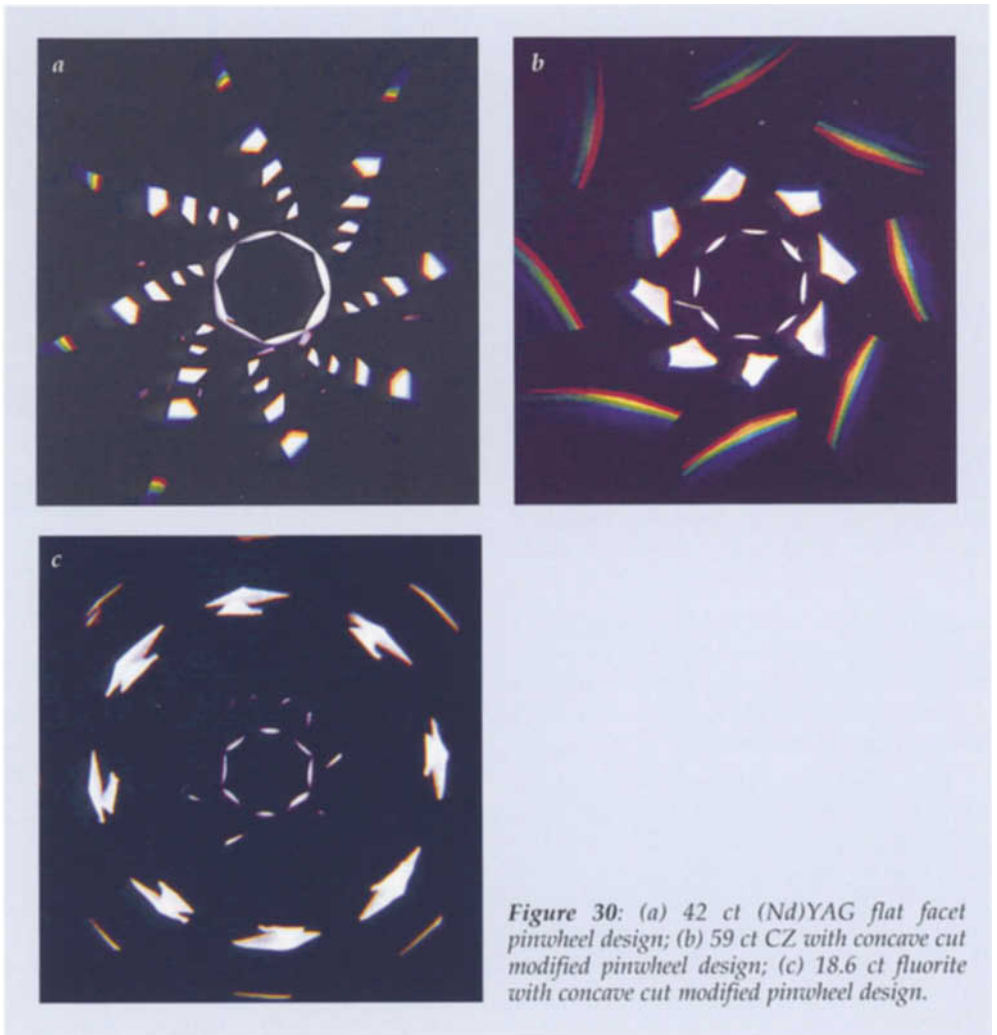

Figure 30: (a) 42 ct (Nd)YAG flat facet pinwheel design; (b) 59 ct CZ with concave cut modified pinwheel design; (c) 18.6 ct fluorite with concave cut modified pinwheel design.

seen using the arrangement as shown in *Figure 29*. Here a triangular prism was cut in CZ and polished to give one facet a flat surface and the adjacent facet a concave surface of radius 11 mm. The prism was supported above a white screen, and a collimated beam of white light (quartz-iodine) projected on to the facets as in the Nelson Gem Fingerprinter⁽¹³⁾ so that the emerging refracted rays after passing through the prism could form images on the screen and be photographed. The left-hand image shown in *Figure 29* was produced by the beam refracted and dispersed by passing

through the facet, whereas the right-hand image produced by refraction of the beam passing through the concave facet shows that it is lengthened perpendicularly to the axis of the cylinder owing to divergence of the beam as well as producing a spectrum by dispersion.

The 42 ct (Nd)YAG pinwheel flat facet design stone as shown in *Figure 1*, and the cubic zirconia and fluorite as shown in *Figures 26* and *27* having a modified concave faceted pattern were submitted to Dr J. Nelson for characterization in the Nelson

Gem Fingerprinter, and the remarkable images, clearly showing the divergence of the emerging rays, are shown in *Figure 30 a, b* and *c*.

Conclusion

The cutting of concave facets on a gemstone in place of the normal flat facets has a profound effect upon the appearance of the stone, in terms both of overall brilliance and of aesthetic beauty, and further enhancement may be achieved by a concave girdle replacing the round or rectangular cutting.

The stone becomes a transparent medium consisting of cylindrically concave lenslets and convex mirror surfaces, resulting in divergence of incident ray paths to produce elongated streaks of light instead of plane reflections of the light source.

The faceting equipment needed to cut the concave facets is not complex, but needs to be rigidly constructed and have facilities for microadjustment of related components. It is an advantage for the cutting cylinders to oscillate along the cylindrical axis so avoiding formation of wear grooves on the cylinders. The cutting grits, polishing sequence and type of material used for the cylindrical laps need not differ from those used in normal lapidary practice.

Although the use of concave cut facets is not new to the lapidary industry, the introduction on the market of commercial equipment for this special method of faceting has opened up a new avenue for exploration of cutting designs. The work of American concave faceters is in great demand for custom jewellery, and has already attracted the attention of skilled amateur faceters in this country.

Acknowledgements

The author would like to thank C. Algar, London, for helpful information concerning his faceting machine and supplying photographs of his specially cut stones; Professor H. Bank of Gebruder Bank, Idar

Oberstein; Manfred Wild of Emil Becker, Kirschweiler, for the loan of stones and details of the cutting methods; Jim Finlayson, Alsager, for details of the Facetron machine; Zane Hoffman for photographs and details of the OMF machine from his web site; Dr J. Fletcher, Nottingham, for the ZEMAX computer ray tracing; Gwyn Green, Birmingham, for information and the loan of the 'Daisy' cut smoky quartz; Alan Hodgkinson, Portencross, Ayrshire, for photographs of the stone by Art Grant; Al Manestar, Toronto, for allowing the author to photograph the Canadian Maple Leaf stone; Dr Jamie B. Nelson, London, for the Gem Fingerprinter photographs; K. Pitt, IT consultant for much help and advice, and Neil Rose of Gem-Ro Associates Ltd, Leeds, for the ImageDome photographs of the CZ and fluorite concave cut stones.

References

1. Maloney, Jr, W.J., 1971. The Dandelion cut. *Lapidary Journal*, 25 (12), 1268-9
2. Personal communication, Manfred Wild
3. Personal communication, A. Green
4. Homer, R.P., 1990. The OMF Faceter. *Lapidary Journal*, 44 (6), 26-34
5. Prosper, S., 2002. The art of concave faceting. *Canadian Gemmologist*, 23 (2) 56-9
6. Personal communication, J. Finlayson
7. Algar, C., 2001. Concave faceting. *Rock 'n' Gem Magazine*, Issue 16, 4-5
8. Personal communication, C. Algar
9. Peatol Precision Lathe agents in UK, Peatol Machine Tools, Birmingham
10. Ultra Tec Faceting Machine, manufactured by Ultra Tec, Santa Ana, CA 92701, USA
11. Lee Faceting Machine, manufactured by Lee Lapidaries Inc., Cleveland, Ohio 44111, USA
12. ZEMAX version 6, produced by Focus Software Inc., Tucson, Arizona, USA
13. Nelson Gem Fingerprinter, manufactured by Nelson Gemmological Instruments, Hampstead, London

Doubling of images in gemstones

Darko B. Sturman¹ and Malcolm E. Back²

1. Curator Emeritus, Royal Ontario Museum, Canada
2. Department of Earth Sciences, Royal Ontario Museum, Canada

ABSTRACT: Equations for determination of the doubling effect in uniaxial minerals are presented for the first time in the gemmological literature. Diagrams are constructed in order to avoid calculations involving trigonometric functions. These diagrams can also be used for estimates of the doubling in biaxial minerals. The importance of the view point is discussed and determination of the doubling in synthetic moissanite is given as an example.

1. Introduction

Doubling of images can downgrade the appearance of an otherwise perfectly cut gem. For example, a sharp pavilion edge viewed through a gem table may appear as two lines or as a broad line (if two images are very close) and the edges may appear 'fuzzy'. To the best of the author's knowledge, this is the first attempt to present equations and diagrams for determination of doubling effects.

Ideally, any presentation of the new ideas must be supported by enough evidence or facts, so that an author's reasoning and conclusions can be independently duplicated and verified. This need should be balanced with the known unwillingness of some readers to follow complex calculations and detailed explanations.

For this reason the paper is divided into a main part (giving diagrams for determinations of doubling effects) and Appendices A and B (giving all other relevant information).

1.1. Birefringence and doubling of images

In general, when light enters a birefringent mineral, it is split into two rays.

These two rays have different refractive indices (birefringence) and different vibration directions. There is also another important difference – these two rays may move in slightly different directions resulting in the separation (doubling) of images (*Figure 1*).

To show the effect of birefringence on these two rays, the difference in their refractive indices and their difference in speed are calculated. It is an easy calculation as the speed is reciprocal to refractive index. From this we can find the distance by which one ray is ahead of the other as they exit the gemstone. They can be separated (move in slightly different directions) or they can move in exactly the same direction as they travel through the gemstone, but we are only concerned with the difference in speed and how far one ray is ahead of the other when they exit the gemstone. They keep this distance as they move through the air to the observer but the human eye cannot observe this effect. *A polariscope or polarizing microscope must be used to identify birefringence effects.*

To show the effect of doubling, the separation of images can be calculated and expressed in millimetres. The human eye can observe a very small separation of

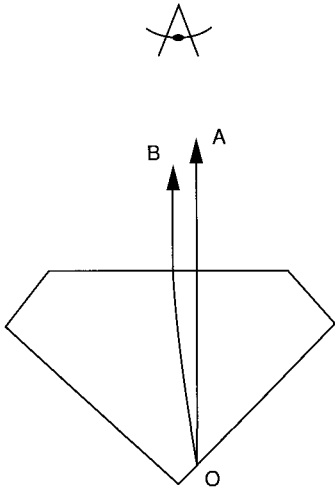

Figure 1: Light reflected at point O is split into two rays A and B. The position of the eye is indicated by arrows at the end of the light rays.

images – as small as 0.1 to 0.2 mm. For example, in *Figure 1* the image of a point on the pavilion facet moves through a gemstone as two separate rays. The angle of separation between the two rays determines the eventual observed distance between the two images. It is not important how far ahead one ray is compared with the other – *the doubling*

of images depends only on the difference in direction of the two rays.

- 'Birefringence' is the numerical difference in the refractive indices of the two rays.
- 'Doubling of images' or 'separation of images' are terms used to describe the effect caused by the separation of directions of the two rays.

Terms such as 'anisotropic minerals', 'birefringent minerals' or 'doubly refractive minerals' have the same meaning. They refer to minerals in which light is split into two rays except when it is moving in the special directions called 'optic axes'.

1.2. Examples of differences between doubling effects and birefringence

Birefringence and the doubling of images are both directional properties of minerals. They depend on the direction in which light moves through a gemstone. However, they are not identical and separate methods must be used to calculate their effects. The following examples show that the direction of maximum birefringence is not the direction of maximum separation of images – it could be just the opposite in some minerals.

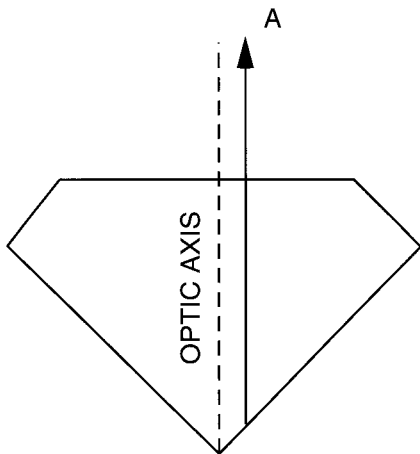

Figure 2: Uniaxial minerals. Light travels in a direction parallel with the optic axis. It is not split into two rays but moves as a single ray. No doubling of images is observed.

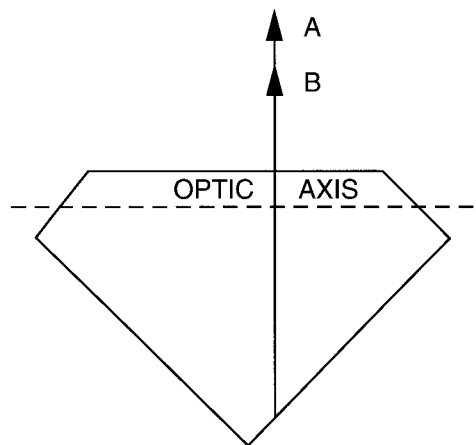

Figure 3: Uniaxial minerals. Light rays travel in a direction perpendicular to the optic axis. It is split into two rays A and B that move in the same direction. No doubling of images is observed.

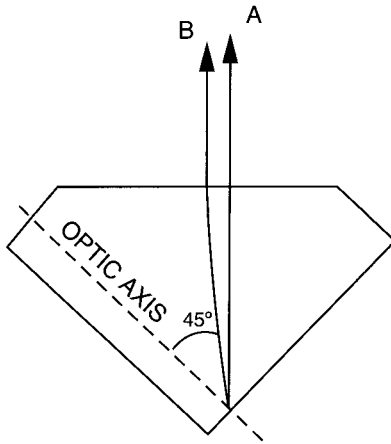

Figure 4: Uniaxial minerals. Light travels in a direction making an angle of about 45° with the optic axis. Light is split into two rays with the maximum separation of images.

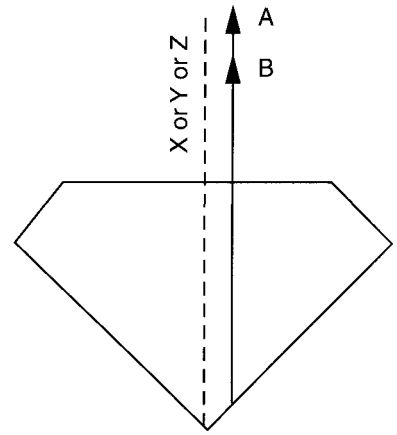

Figure 5: Biaxial minerals. Light travels in the direction of one of the principal vibration directions Z, Y or X. It is split into two rays A and B that move in exactly the same direction. No doubling is observed.

Uniaxial minerals
Tetragonal and hexagonal

When light travels in the **direction parallel to the optic axis**, it continues as a single ray (Figure 2). There is no birefringence and **no doubling of images is observed**.

When light travels in the **direction perpendicular to the optic axis** it is split into two rays (Figure 3). These two rays show the maximum difference in the refractive indices for this mineral – maximum birefringence but the light rays continue to travel in exactly the same direction. **No doubling of images is observed.**

When light travels at an **angle of about 45° to the optic axis** it is split into two rays (Figure 4). These two rays show birefringence that is about half of the maximum for this mineral, but the rays are separated by the maximum possible angle of separation. **Maximum doubling of images is observed.**

Biaxial minerals

Orthorhombic, monoclinic and triclinic

When light travels in the **direction of one of the three principal vibration directions** (X, Y, Z, also given as α, β, γ) it is split into two rays with different refractive indices, but they continue to travel in exactly the same direction (Figure 5). **No doubling of images is observed.**

These examples clearly show that the effects of birefringence and effects of doubling of images must be presented and calculated in different ways.

1.3. Factors determining doubling of images

The actual observed doubling of images (distance D in Figure 6) depends on two factors:

- **The size of the gemstones** – thickness of the gemstone in Figure 6. Simply stated, larger gemstones will show more pronounced doubling of images than smaller gemstones. The effect of gemstone

size can be calculated from a simple equation given later.

- **The angle of separation of two rays** – angle α in *Figure 6*. This angle of separation (in uniaxial minerals) can be calculated from two different equations.
 - a) A relatively simple equation can be used to calculate the maximum possible angle of separation for a particular mineral from its main refractive indices. This presumes that the gemstone table is oriented in the worst possible position relative to the optic axis.
 - b) The second equation is more complex because it involves orientation of the gemstone table in relation to the optic axis. Calculations show how angles of separation change as the angles between optic axis and gem table vary from 0° to 90° .

Diagrams 1 and 2 are prepared from these equations so that calculations involving trigonometric functions can be avoided. Detailed descriptions of each diagram and its use are given in separate sections on uniaxial minerals. This is followed by description of the use of diagrams for estimates of doubling effect in biaxial minerals. The equations used for the construction of the diagrams are given in Appendix A.

The importance of the view point is explained in Appendix B1. *Figures 1–9* and both diagrams are based on observation through a gem table with the eye set over the centre of the gem table. In this arrangement rays that are perpendicular to the gem table as they exit the gemstone are observed. In Appendix B2 synthetic moissanite is used as an example of identification of doubling effects as they are observed from different viewpoints. Finally, in Appendix B3 instructions are given on the use of calcite plates in observing the effects of various degrees of doubling or separation.

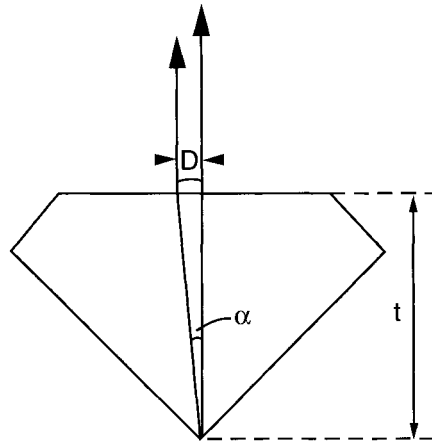

Figure 6: Distance between images D depends on the separation angle α and the thickness t of the gemstone.

2. Gem size

The actual visible doubling of images in a particular gemstone depends on the angle of separation of the two rays and the distance they travel in a gemstone (*Figure 6*). In this section the effect of size is examined and in the following sections determination of the separation angle α is discussed.

The effect of gemstone size can be calculated from the simple equation

$$D = t \cdot \tan \alpha \quad \text{Equation 1}$$

where D is the observed distance between images (*Figure 6*), t is the thickness of a gemstone and angle α is the separation angle of the two rays. Separation angle α can be calculated from equations 2 and 3 described in the following sections.

- In order to avoid calculation involving trigonometric functions, two diagrams have been constructed for gemstones 10 mm thick, here called the ‘standard’ thickness to show the doubling effect.

We can get a fairly good estimate of doubling effect just by comparing the size of a particular gemstone to a ‘standard’ size (10 mm) used in the diagrams. A gemstone twice as large (about 20 mm in depth) shows twice the doubling effect.

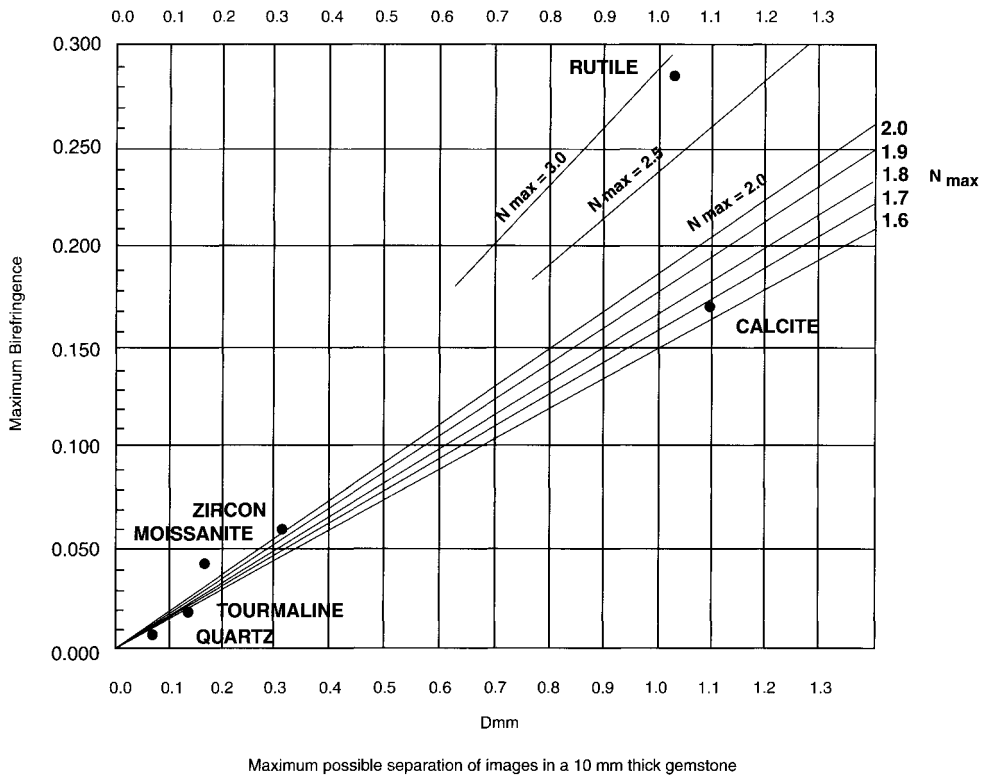

Diagram 1: The maximum possible separation of images for a particular mineral. Use of diagram: plot the maximum birefringence on the vertical axis, move horizontally to diagonal lines representing N_{max} and read the maximum separation of images on the horizontal axis. Diagram is based on calculations for 10 mm thick gemstones.

- For more accurate estimates the thickness of a particular gemstone should be measured and compared with the 'standard' size used in the diagrams (10 mm). For example, in *Diagram 1* we see that a 10 mm zircon can show a maximum doubling effect (separation of images) of 0.31 mm. (A detailed description of the use of *Diagram 1* is given in the next section.) A zircon gemstone with a thickness of 7 mm shows separation of images of 0.7×0.31 mm = 0.22 mm and one with a thickness of 13.5 mm shows separation of images of 1.35×0.31 mm = 0.42 mm.

Simple multiplication combined with the use of diagrams can give fast and fairly accurate estimates of the doubling effect if the size (thickness) of the gemstone is known.

3. Uniaxial minerals

3.1. Maximum possible separation of images in a mineral

The optical properties of a mineral, namely the maximum birefringence and the refractive indices can be used to calculate the maximum possible doubling effect that can be observed in a particular mineral.

- In uniaxial minerals the maximum possible doubling effect is observed when light travels in directions which are at about 45° to the optic axis (*Figure 4*).

In Appendix A.1 the information is given (Equation 2) for determination of the maximum possible separation angle α for a particular mineral (see *Figure 6*). In order to

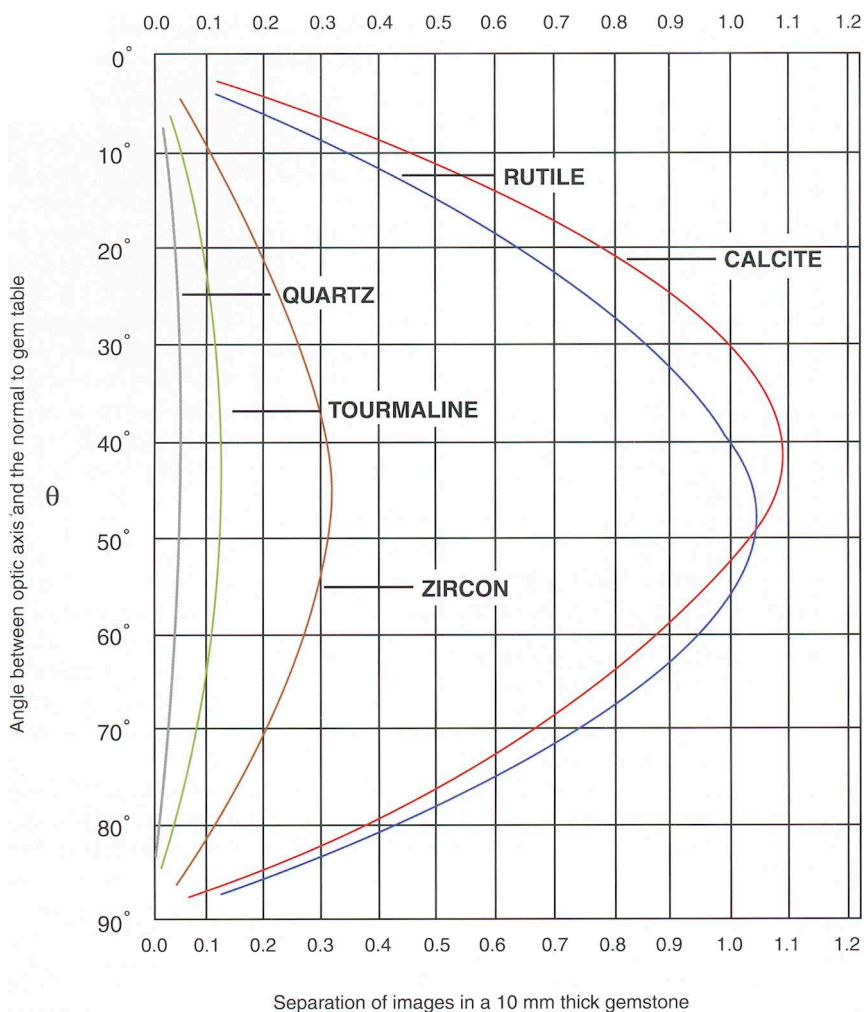

Diagram 2: Orientation of gem table and doubling effect. Use of the diagram: plot the angle θ (the angle between the optic axis and the normal to the gem table) on the vertical axis, move horizontally to curved lines representing selected minerals and read the separation of images on the horizontal axis. Diagram is based on calculations for 10 mm thick gemstones.

avoid complex calculations this equation was used with Equation 1 (concerning gem size) in construction of *Diagram 1*. A 10 mm thick gemstone was used as the 'standard'.

The use of the diagram is very simple. The maximum birefringence of a mineral is read from the vertical axis. Then one moves horizontally to the diagonal line representing the maximum refractive index and on the

horizontal axis of the diagram the maximum possible separation of images for a gemstone of the 'standard' size (10 mm) is read.

- The only calculation left to do is to compare the size of the particular gemstone to the standard size. Examples are described in the section on gem size.

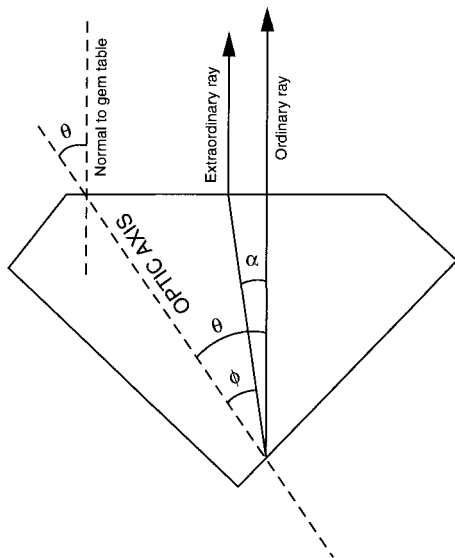

Figure 7: The separation angle α is the difference between angles θ (optic axis and ordinary ray) and ϕ (optic axis and extraordinary ray). Note that the angle θ is identical to the angle between the optic axis and the normal to the gem table.

A quick overview of *Diagram 1* shows that maximum birefringence plays a very important role in the calculation of doubling effects for a particular mineral. Minerals with strong maximum birefringence show strong separation of images. However, a minor but important role is played by the maximum refractive index (whether the ray with maximum refractive index is N_o or N_e does not matter in this context).

For example, rutile and calcite show a similar maximum possible distance between images in 10 mm thick gemstones. Rutile has almost twice the birefringence of calcite but this is compensated by the much higher refractive indices of rutile. Evidently, both factors determine the maximum doubling effect that can be observed in a particular mineral.

- Maximum birefringence plays a major role; minerals with larger birefringence show larger maximum possible doubling effect.

- Refractive indices play a minor role: minerals with larger refractive indices show smaller maximum doubling effect.

3.2. Orientation of the optic axis in the gemstone

Until now we have discussed the maximum possible doubling that can be observed from a particular mineral – ‘the worst case scenario’. It is observed in gemstones cut from uniaxial minerals when the optic axis is set at about 45° to the gem table. It was mentioned in the introduction that no doubling is observed when the optic axis is either parallel or perpendicular to the gem table. In all other orientations of the optic axis doubling effects vary from the maximum possible to zero. These are shown in *Diagram 2*.

Appendix A.2 contains the equations used in construction of *Diagram 2* which was prepared in a similar way to *Diagram 1*. A 10 mm thick gemstone is used as ‘standard’. This means that the only calculation left to do is to compare the thickness of a particular gemstone with the ‘standard’ – as shown in the section on gem size.

The vertical axis of *Diagram 2* shows the angle θ – the angle between the optic axis and the normal to the table facet of the gem (see *Figure 7*). The angle θ is 0° when the optic axis is perpendicular to the gem table and it is 90° when it is parallel to it. In these positions the separation of images is 0.

The use of the diagram is as follows: plot the angle between the optic axis and the normal to the gem table (angle θ) on the vertical axis, move horizontally to the curve representing the particular mineral and read the separation of images (doubling effect) on the horizontal axis of the diagram.

- The most striking feature of *Diagram 2* is that the curves are almost symmetrical. For example, almost the same doubling effect (separation of images) is observed when the angle between the optic axis and gem table facet is $\theta = 20^\circ$ or when it is $\theta = 70^\circ$.

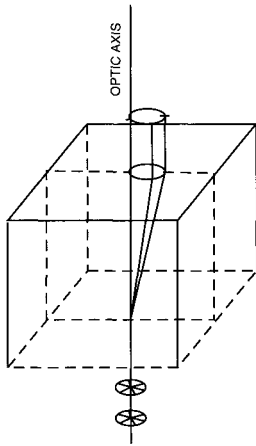

Figure 8: Conical refraction in biaxial minerals. Light travelling in the direction of an optic axis in biaxial minerals becomes a hollow cone as it moves through the gemstone and continues in the air as a hollow cylinder.

- Another important feature is that the maximum doubling effect is observed when the angle θ is about 45° . It is not exactly 45° (see calcite and rutile curves) but in practice this value can be used as the position with the maximum doubling effect.

On *Diagram 2* curves for five minerals have been plotted to indicate how the doubling effect changes at various orientations of optic axis in the gemstones. The curve of any other mineral can be plotted by using *Diagram 1* to determine the maximum possible separation of images in a particular mineral; then plot this on *Diagram 2* at the position of $\theta = 45^\circ$. From this point draw symmetrical curves to 0° and 90° . For practical purposes this will enable sufficiently good estimates to be made.

4. Biaxial minerals

Calculations of the doubling of images for birefringent biaxial minerals (orthorhombic, monoclinic and triclinic) are more complex than for uniaxial minerals. However, the diagrams presented for uniaxial minerals can

be used as fairly reliable estimates of the doubling effect.

In uniaxial minerals there are two important directions – parallel to the optic axis and perpendicular to it. In biaxial minerals there are three important directions called the principal vibration directions which are marked as X, Y and Z, or α , β and γ . Related to these directions are the principal refractive indices often marked as N_x , N_y , and N_z , or as N_α , N_β and N_γ .

In addition, in biaxial minerals there are two special directions – two optic axes that can be compared to the optic axis of the uniaxial minerals. The angle between the optic axes is known as $2V$ and can lie between 0° and 90° with either X or Z as acute bisectrix. The angle $2V$ depends on the values of N_x , N_y , and N_z . Minerals with a very small $2V$ behave similarly to uniaxial minerals as far as estimates of birefringence and doubling of images are concerned.

- *Diagram 1* was constructed for uniaxial minerals but can be used for estimates of the maximum possible doubling effects for biaxial minerals if N_z is used for N_{\max} and N_x for N_{\min} .

In biaxial minerals there are three directions where the separation angle α is 0° and there is no doubling of images. It is a similar effect to that seen in uniaxial minerals when light travels perpendicular to the optic axis (*Figures 3 and 5*).

- When light travels parallel to the principal vibration direction Z, Y or X, it is broken into two rays with different refractive indices, but both rays move in exactly the same direction and no separation of images is seen.
- Strong doubling of images is seen when light travels in a direction equally inclined to all three principal vibration directions

or in the directions which are at 45° between Z and Y, or X and Y.

An additional adverse effect that may be observed in biaxial minerals is known as conical refraction (*Figure 8*). Light travelling in the direction of an optic axis becomes a hollow cone of light within a gemstone, and continues in the air as a hollow cylinder. This may cause unpredictable optical effects in gems and should be avoided. In uniaxial minerals, a gem table set perpendicular to the optic axis is a very desirable position. In biaxial minerals it may not be.

5. Conclusion

Doubling of images in uniaxial minerals can be accurately calculated from the equations given in Appendix A. However, very fast and reliable estimates can be obtained from the presented diagrams.

Diagram 1 gives the maximum possible doubling effect for a particular mineral and is based on its maximum birefringence and refractive indices. *Diagram 2* shows how the doubling effect changes with the angle between the optic axis and table facet of the gem.

In uniaxial minerals no doubling is observed when light travels in directions perpendicular or parallel to the optic axis. The maximum doubling effect is observed when light travels in the directions making about 45° with the optic axis.

Diagrams and equations are presented for uniaxial minerals. However, they can also be used for fairly good estimates of the doubling in biaxial minerals. In biaxial minerals no doubling is observed when light travels in directions of the principal vibration directions (Z, Y or X).

The position of the eye over the gemstone plays a very important role. Diagrams and equations relate to light rays that are perpendicular to the gem table as they enter the air. These rays are observed when we look through the gem table with the eye positioned directly above its centre (*Figure 1*).

Determination of the doubling effects for other view points is a more complex process, but diagrams can be used for fast and useful estimates.

Determination of the doubling effect can be a useful tool in identification of gemstones. It can also be useful in deciding the orientation of rough gem material for cutting the table facet and in the ultimate size of the stone.

Acknowledgements

We wish to thank Brian Joyce for introducing this problem to us. His keen observations combined with literature search showed that doubling is not adequately described in textbooks. We also thank him for drawing some of the figures. We were also very impressed with the interest and insight into many gemmological problems by other members of the North York Faceting Guild. Without their support and encouragement this paper would not have been published.

We also appreciate many useful discussions and suggestions from my colleagues in the Royal Ontario Museum – Dr Robert Gait and Dr J.A. Mandarino. We are thankful to Willow Wight, the Editor of the *Canadian Gemmologist*, and Quintin Wight for the critical reading of this manuscript. Comments from Dr A.J. Allnut improved the manuscript.

References

- Baric, L., 1967. *Mikrofiziografija Petrogenih Minerala*. Skolska Knjiga, Zagreb, Croatia
- Wahlstrom, E.E., 1979. *Optical crystallography*, 5th edn. John Wiley & Sons, New York

Appendix A

Equations for doubling in uniaxial minerals

A.1. Maximum possible separation of images in a mineral

Baric (1967) gives a simple equation for calculation of the maximum possible separation angle α for a particular mineral:

$$\tan \alpha_{\max} = \frac{N_{\max}^2 - N_{\min}^2}{2 \times N_{\max} \times N_{\min}} \quad \text{Equation 2}$$

where α_{\max} is the maximum possible separation angle between two rays (Figure 6) and N_{\max} and N_{\min} are the main refractive indices N_o and N_e .

We do not have to differentiate the optically positive minerals from the optically negative and for this reason we use symbols N_{\max} and N_{\min} in Equation 2.

If this separation is to be expressed as a distance D (in millimetres) in Figure 6 the size of a gemstone must be known. A larger gemstone will produce a larger distance between the images. Therefore, in the calculations Equation 2 is first used to determine the maximum possible separation angle (α_{\max}) and then the size of a gemstone is introduced using Equation 1 to calculate the actual separation of images (distance D in Figure 6).

A.2. Orientation of the optic axis in the gemstone

Figure 7 shows an example of the paths of the ordinary ray and the extraordinary ray in a uniaxial positive mineral. If we set our eye over the centre of the gem table, then the ordinary ray is perpendicular to the gem table and is undeviated as it passes from gem to air. The extraordinary ray moves in a slightly different direction in the gemstone, but is bent as it exits the gemstone to become parallel to the ordinary ray. In the air these two rays are parallel and maintain the separation they had at the gem surface.

The following equation (modified from Wahlstrom, 1979) can be used to calculate the angle between the extraordinary ray and the optic axis (angle ϕ) as it moves through the gemstone:

$$\tan \phi = \frac{N_o^2}{N_e^2} \times \tan \theta \quad \text{Equation 3}$$

where ϕ is the angle between the extraordinary ray and the optic axis, N_o and N_e are refractive indices and θ is the angle between the ordinary ray and the optic axis (Figure 7).

In uniaxial positive minerals the extraordinary ray is refracted toward the optic axis and in uniaxial negative minerals it is refracted away from the optic axis. Therefore, angle ϕ can be either larger or smaller than θ .

However, we are only interested in the difference between angles θ and ϕ – the separation angle α in Figure 7. Thus:

$$\alpha = \theta - \phi \text{ or } \alpha = \phi - \theta \quad \text{Equation 4}$$

If we wish to determine the doubling effect in a gemstone made from a particular mineral, angle ϕ is first calculated from Equation 3 and then the separation angle α from Equation 4. Then the size of the gemstone is inserted in Equation 1 to determine the actual distance between images in millimetres.

- More rapid estimates can be obtained using Diagram 2 which was constructed using Equations 3, 4 and 1. Calculations are based on a 10 mm thick gemstone.

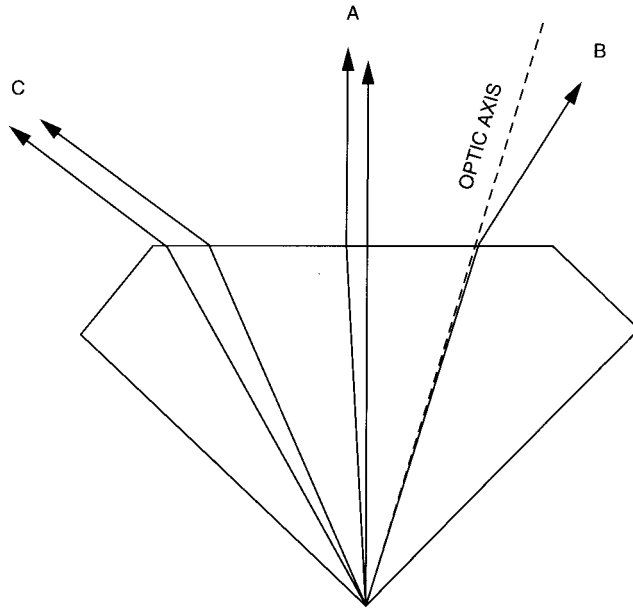

Figure 9: Ray A is split into two rays – the ordinary ray is perpendicular to the gem table. Ray B travels in a direction parallel to the optic axis – it continues as a single ray. Ray C travels in a direction at about 45° to the optic axis – it shows the maximum doubling effect.

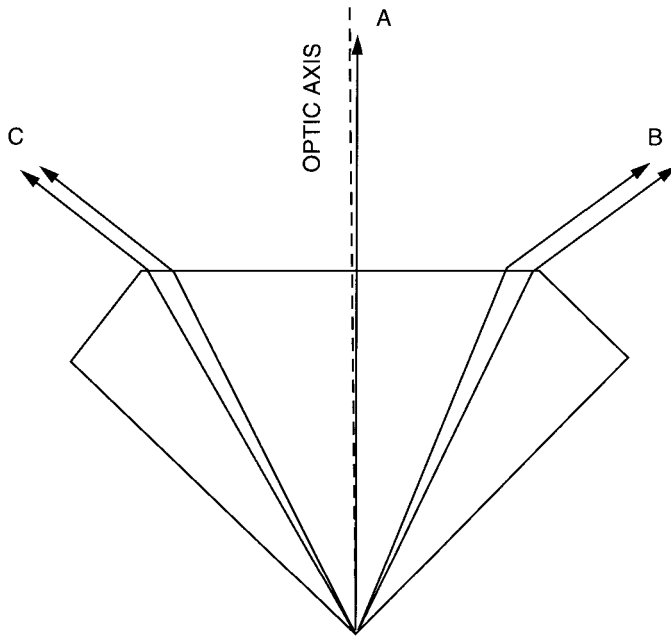

Figure 10: Ray A moves in the direction of the optic axis as a single ray. Rays B and C travel in directions at about 20°–30° to the optic axis and show a doubling effect that is about half of the maximum possible doubling effect for this particular mineral.

Appendix B

Importance of the view point

B.1. Moving the position of the eye over the gem table

In order to see light rays which are perpendicular to the gem table the eye should be positioned perfectly over the centre of the table. *Figures 1–9* and both diagrams have been made for this arrangement. This is a natural position to assume for careful examination of a gemstone.

- However, gemstones are also observed from other positions as they are tilted from side to side. In these positions we see rays that are not perpendicular to the gem table, but travel through the gemstone in many different directions, make different angles with optical elements and, consequently, show different doubling effects.

For example, in *Figure 9*, ray A has a doubling effect that can be determined by using *Diagram 2* as described above. Ray C shows a stronger doubling effect, because it makes a larger angle θ with the optic axis. Ray B travels along the optic axis and shows no doubling effect at all.

We do not have to calculate the doubling effect for all rays exiting the gemstone but we just need to examine the rays that show the maximum doubling effect. If we prepare a simple drawing such as the one in *Figure 9*, we can easily find rays which make the largest angle θ with the optic axis (in uniaxial minerals) and estimate the doubling only for these rays.

Very often the table facet is cut perpendicular to the optic axis of the uniaxial gem minerals (*Figure 10*). In this case, looking through a gem table – no matter how much we tilt the gem (rays C and B in *Figure 10*) – no rays make an angle θ with the optic axis of more than about 30° . These rays will show about one half of the maximum possible doubling effect for that mineral.

Thus, for uniaxial minerals, if the optic axis is **perpendicular to the gem table** we can observe about half of the maximum possible doubling effect (*Diagram 1*) as we look through a tilted gem table.

When making a decision on the orientation of the table facet in rough material of a biaxial mineral that may show a doubling effect – the best way to minimize doubling effects through the table is to set one of the three principal vibration directions (Z, Y or X) perpendicular to the gem table.

B.2. Example: observations on synthetic moissanite

A very fast and reliable test for identification of synthetic moissanite is the observation of the doubling effect. *Diagram 1* shows that the maximum possible separation of images is relatively small – $D = 0.16$ mm in a 10 mm thick gemstone. In smaller gemstones it will be even less, for example a 5 mm thick gemstone can show a maximum separation of images of $D = 0.08$ mm.

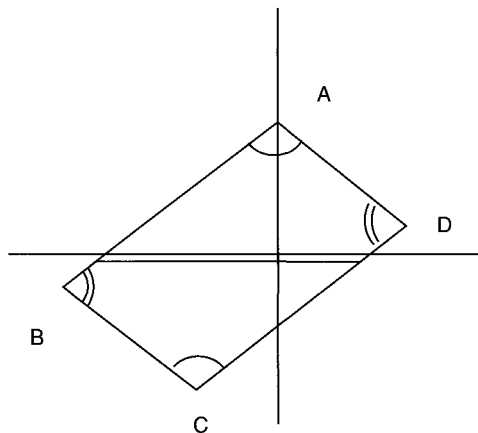

Figure 11: Calcite cleavage plate placed over a cross marked on paper shows doubling of the horizontal line. The vertical line is unaffected.

This would be observed in gemstones where the table facet is at about 45° to the optic axis. However, in most synthetic moissanites the optic axis is perpendicular to the gem table. No matter how much we tilt the gemstone, the doubling effect is difficult to observe in such orientations if we look through the table. Therefore, observation should be through the crown facets.

In practice *Diagram 1* could be used to determine the maximum possible doubling effect for a moissanite gemstone of a certain size, and then checked with a lens or a microscope.

Once we know what to expect and how images should look at different magnifications, we can start the examination of a gemstone. First examination should be through the table facet from various view points, followed by observation through several crown facets – again from various view points. All observations are then compared to arrive at an identification.

B.3. Estimates of the separation of images

Observing a millimetre scale through a lens or a microscope immediately after the observations on a gemstone can give a fairly good estimate of the distance between the images expressed in millimetres.

However, the easiest way to become familiar with the visual effect of various separation distances is to prepare a series of calcite cleavage plates with thicknesses between 1 and 5 mm. A calcite cleavage plate is then set over a cross inked on a sheet of paper and observed from a point directly above the plate.

The calcite cleavage plate is rotated into position as shown in *Figure 11*. One cross line through A appears as a single sharp line (it is actually two lines set exactly one over the other) but the line at the right angle shows doubling. The distance between the doubled lines can be easily calculated by multiplying the thickness of the cleavage plate by 0.11. The orientation of the optic axis in a cleavage plate gives almost the maximum possible separation of images for calcite (see *Diagram 2*).

Birefringence vs. double refraction divergence

Richard Cartier

Toronto, Canada

ABSTRACT: A problem endemic in the field of gemmology that arises from long-standing terminology misuse is discussed. It is posited that refraction refers to action taken by light, while birefringence refers to properties of a medium. The author recommends that use of the plural, the singular, and contractions maintain the same conceptions throughout to avoid optics theory confusion. 'BI' is proposed as a contraction for birefringence and 'DD' is proposed as a contraction for double refraction divergence. It is recommended that 'DR' be discontinued because for too long it has been confused with birefringence.

To describe a medium as doubly refracting is generally considered much the same as describing the medium as birefringent. However, there is an important, if subtle, difference between these descriptions, a difference in root concepts. A birefringent medium has two numerically different indices of refraction which allows double refraction of light. Double refraction requires birefringence, but happens only when refraction (a change in the direction of travel) occurs.

In his classic text on optics¹, Ernest Eugene Wahlstrom elucidates, "The power of a substance to refract light waves is sometimes described as *refringence*. Substances of high refractive index have high refraction; those of low refractive index have low refraction." This clearly indicates that refraction, more commonly referred to in gemmological texts and notes as optical density, is a property of a medium.

The measure of refraction is refractive index (RI), which is sometimes defined as the velocity of light in a vacuum divided by

the velocity of light in the medium. In most fluids or crystalline materials of the cubic system, all light of one wavelength will travel at the same velocity set by the refraction. Upon entering the medium, light will experience a transition in velocity, but may or may not change direction of travel. When there is a change in direction, it is controlled not only by refraction, but also by the angle of incidence. Perpendicular incidence will result in a full reduction in velocity while the light travels straight on.

Birefringence of a medium describes two simultaneous differing optical densities, and this results in two different refractive indices. The measures of the two differing refractions are the refractive indices (RIs) of the medium. The term birefringence, as a quantifiable property, has come to mean the numerical difference between two refractive index readings in one medium for the same wavelength of light. As a measurable property of the medium, birefringence may vary with direction. One may speak of the birefringence in a particular reading, which would be the difference in RI values for the

two mutually perpendicular vibration directions associated with one propagation direction. In a broader context, one may speak of the birefringence of the medium itself (suggested contraction BI rather than DR), which would be the maximum difference in RI value when considering all possible vibration directions within the medium.

Refraction is a change in direction taken by light entering into a material at an angle (usually oblique) to the surface. Double refraction occurs when an incident ray entering into a material experiences being sorted into two rays, each following a different path. Double refraction is an action taken by light passing through a surface into the control of the birefringence of the medium² to yield two rays travelling in different directions; it is simple pluralization of refraction. Strong birefringence can produce easily visible double images, sometimes called doubling. Double refraction refers to what happens to one incident ray, while doubling refers to the more complex situation with a larger number of rays producing images.

Refraction, double refraction, birefringence and refraction should have continuity of concept between the singular and the plural. Refraction and double refraction are actions taken by light in response to interaction with a medium. They can only exist in reference to travelling rays of light. Birefringence and optical density (refringence) should both be considered properties of a medium. They exist whether light is travelling through the medium or not.

A problem endemic in gemmology is use of the phrase 'double refraction' as well as the contraction 'DR' when the concept that is intended is birefringence. Contractions that are more appropriate would be 'Bi', 'Bir' or 'BI' or even 'RI-RI'. The mistaken use of 'DR' leads to a major misunderstanding, incorrectly implying that a ray experiencing birefringence must be doubly refracted. Webster did point out the error of expecting to see double images in the direction of

maximum birefringence³, but he still mistakenly used the term 'double refraction' when he meant birefringence. Understanding the theory is easier when considering a single incident ray, rather than the multiple rays needed to produce an image.

When double refraction happens there must be birefringence, but the reverse is not true at all. Examining a crystal of calcite, the stone renowned for its high birefringence and often used to exemplify double refraction, exposes the error of labelling birefringence as 'DR'. It is perfectly possible to have unorganized light sorted into two polarized rays with different properties, and yet neither of the two rays change their direction of travel. Calcite shows that we can easily have birefringence without refraction much less double refraction.

The direction along the length of a prismatic calcite crystal is the optic axis, and therefore shows zero birefringence (BI = nil) and no double refraction divergence (DD = nil). A prismatic crystal of calcite allows us to look squarely through a prism face. This direction is 90° to the optic axis, so must be the direction of maximum birefringence (BI = max). A ray of light entering squarely through the prism face experiences this maximum birefringence. It will be sorted into two rays one travelling at the fastest velocity allowed in the crystal, the other travelling at the slowest velocity imposed by the crystal. Because the incidence is along the wave normal, no refraction takes place. If there is no refraction, it logically follows that there is no plural refraction because there is no degree of divergence (DD = nil). Both rays travel straight on, the fast ray racing ahead, the slow ray lagging behind.

This concept of the degree of divergence between doubly refracted rays that originated from one incident ray, can logically be contracted to 'DD' while 'BI' could serve as the abbreviation for birefringence. The following summary uses these designations to indicate, in general terms, the relationship between double

Uniaxial stones (tetragonal, hexagonal, and trigonal crystals; *one optic axis*)

U.1	One reversible direction along the optic axis ⁵	BI=nil, DD=nil
U.2	All reversible directions 90° to the optic axis	BI=max, DD=nil
U.3	All reversible directions equally oblique to optic axis at angle of maximum doubling	BI=intermediate, DD=max
U.4	All other directions	BI=intermediate, DD=intermediate

Biaxial stones (orthorhombic, monoclinic, and triclinic crystals; *two optic axes*)

B.1	Two reversible directions along the optic axes ⁶	BI=nil, DD=nil
B.2	One reversible direction 90° to both optic axes	BI=max, DD=nil.
B.3	One reversible direction centred in the acute angle between the optic axes	BI=intermediate, DD=nil
B.4	One reversible direction centred in the obtuse angle between the optic axes	BI=intermediate, DD=nil
B.5	Two reversible directions equally oblique to both optic axes	BI=intermediate, DD=max
B.6	All other directions	BI=intermediate, DD=intermediate

refraction and birefringence for directions of normal incidence into anisotropic materials. It is based on the understanding that when a ray coincides with a wave normal there will be no refraction at normal incidence⁴.

Comparing the U.3 and B.5 conditions in the summary suggests a potential explanation why the most familiar cases where doubling is easily visible occur in uniaxial stones such as calcite, zircon and synthetic moissanite. In uniaxial stones, there are theoretically an infinite number of reversible directions of maximum double refraction divergence while in biaxial stones there are only two reversible directions of maximum double refraction divergence!

Conclusions

Birefringence and double refraction are related, but should be considered as two

different concepts; one concerns properties of the medium, the other, actions of light. If the root of a word is 'refract' then the essential consideration is action taken by light (with regard to changing the direction of travel). If the root of a word is 'refrange' then the essential consideration concerns the properties of a medium (with regard to setting the velocity of light). A prismatic crystal of calcite is a doubly refracting medium for light incident oblique to a prism face or for light incident normal to a rhombohedron face. It is not doubly refracting, however, for light travelling along the length of the crystal or for light incident normal to a prism face because this light does not refract and there is no divergence. If a contraction or short form of birefringence is desired, then perhaps 'BI' could serve instead of the erroneous 'DR'.

References

1. *Optical Crystallography*. 5th Edition. ISBN 0-471-04791-0, p.50
2. In some cases, the angle of incidence can be normal to the surface, and in some cases only one of the two rays refracts, but oblique incidence with both polarized rays refracting is the most common case of double refraction.
3. *Gems*. 5th Edition. pp. 667-8.
4. Any good optics text will contain diagrams of the wave-vector surface or ray velocity surface for anisotropic cases to help clarify these instances where normal coincidence will yield no refraction. One recommended example would be *Introduction to Modern Optics*, 2nd Edition. ISBN 0-48665957-7, Figure 6.9, p.174, by G.R. Fowles. (The wave normal direction is perpendicular to the tangent on the surface.) Wahlstrom shows a good diagram of the relationship between ray-velocity surfaces, the indicatrix, and the two kinds of optic axes in his Figure 11-8, p. 280.
5. Circular birefringence, which produces optical activity (rotation of linear vibration), is ignored because cases of coherent circularly vibrating incident light are seldom encountered or considered, and in cases of optical activity velocity is constant for linearly polarized light.
6. Conical refraction, which occurs in the direction of the optic axes in biaxial media (when every vibration direction that shares the same wave normal has a slightly different velocity), is ignored because this optic axis is defined by wave-normal velocity, not ray-velocity.

NEW!!

PORTABLE GEM AND DIAMOND KITS

Essential testing equipment contained in a handy zip travel case

Gem Kit 1

£169.50

18mm 10x loupe, S/S tweezers (medium), stone cloth, conoscope rod, Chelsea colour filter, London dichroscope (polaroid), diffraction spectroscope, flexi torch, folding polariscope

Diamond Kit 1

£67.00

18 mm 10x black loupe, black tweezers (medium), parcel No 1 papers, stone scoop, LW UV keyring, diamond cloth, spread gauge 0.01-4 ct

Larger Gem and Diamond Kits also available – full details given on the Gem-A website at www.gem-a.info

Prices exclusive of VAT and postage and packing



Gem-A
Instruments

27 Greville Street, London EC1N 8TN t: 020 7404 3334 f: 020 7404 8843

Verneuil synthetic sapphire showing an iron absorption spectrum

J.M. Duroc-Danner, FGA, GG

Geneva, Switzerland

ABSTRACT: Normally iron absorption spectra are characteristic of natural sapphires which owe their colour mainly to traces of iron. If titanium is also present, the $\text{Fe}^{2+} \rightarrow \text{Ti}^{4+}$ inter-valence charge transfer gives sapphire its blue colour. The intensity of the absorption depends on the iron content which varies according to the origin of the sapphire (basaltic or non-basaltic) and can be further modified if heat treatment or diffusion treatment is applied. An iron spectrum has been observed in a 7.02 ct Verneuil synthetic sapphire which is most unusual and this is described in detail.

Introduction

Recently the author was asked to identify a 7.02 ct oval brilliant-cut blue stone measuring $12.49 \times 10.67 \times 6.35$ mm which looked very similar to heat treated sapphires from Sri Lanka (*Figure 1*). Careful examination however, revealed some unusual features and the gemmological properties of the stone are described below.

Gemmological properties

The gemstone displayed a vitreous lustre, and its SG, obtained by hydrostatic weighing, is 4.00.

The refractive index (RI) determinations were carried out using a Rayner Dialdex refractometer and monochromatic sodium light, and those obtained from the table facet were $\omega = 1.768$, $\epsilon = 1.760$, giving a birefringence of .008 with optic sign negative. This indicated that the table facet was cut parallel to the *c*-axis and was

confirmed when a uniaxial interference figure was obtained on the stone's girdle plane. Under a calcite dichroscope, a distinct dichroism in pale greenish blue and deep blue was observed.

The absorption spectrum, visible through a Beck hand-held spectroscope, revealed an absorption ray typical of iron, at 450 nm,



Figure 1: Oval brilliant-cut blue stone weighing 7.02 ct.

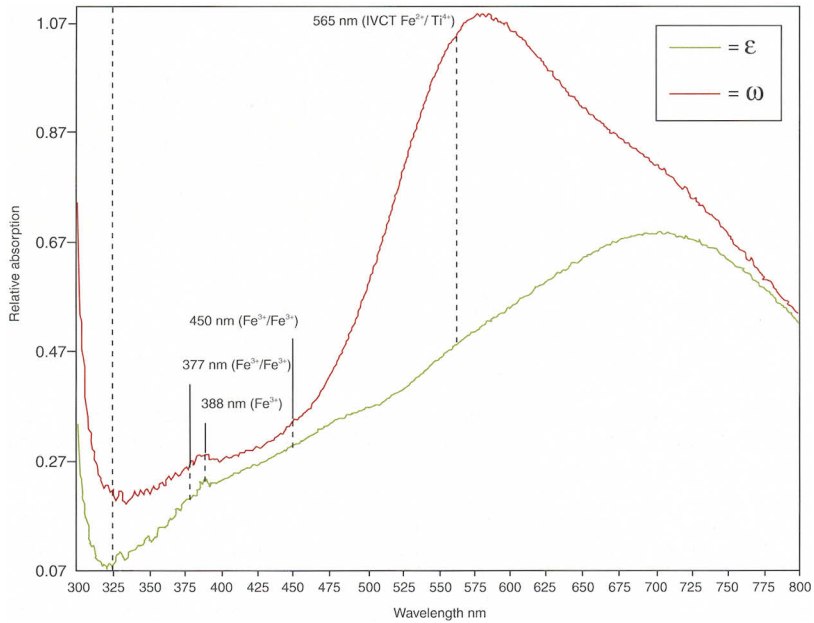

Figure 2: UV-visible spectra of ordinary and extraordinary rays in a Verneuil synthetic sapphire of 7.02 ct.

visible in the optic axis direction, parallel to the table facet. This was confirmed in spectra obtained using the UV-visible spectrophotometer (Figure 2), which revealed:

- Two broad absorption bands around 585 nm for the ω -ray, and around 703.5 nm for the ϵ -ray (although slightly higher than
- the figures of 565 nm and 700 nm usually mentioned in literature and ascribed to $\text{Fe}^{2+} \rightarrow \text{Ti}^{4+}$ inter-valence charge transfer (IVCT), which is responsible for the blue colour of the sapphire)^(1,2,3,4)
- The absorption lines at 328 nm, 377 nm, and 388 nm, present in the ω -ray and ϵ -ray spectra.



Figure 3: Polishing 'fire marks' near facet junctions on the pavilion. 40 \times .

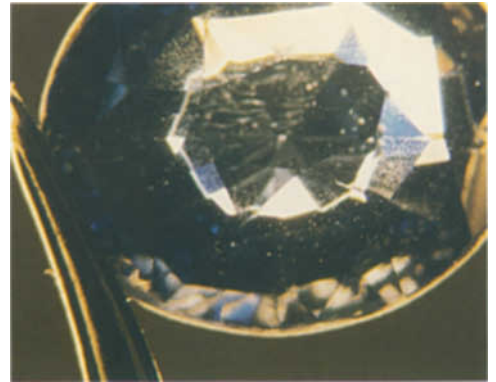

Figure 4: Numerous gas-filled pin-point inclusions forming a 'phantom-like' fingerprint under the table facet. 15 \times .

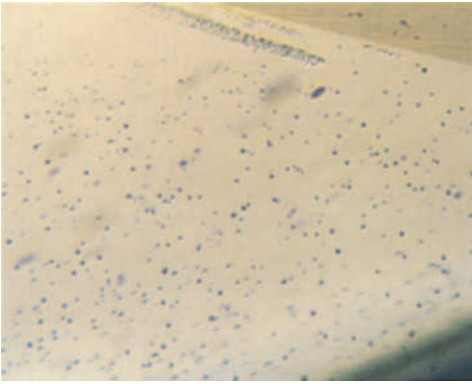

Figure 5: Enlarged view of the halos around the pin-points shown in Figure 4. 60 ×.

- A weak line centred at 450 nm in the ω -ray spectrum, but absent in the ϵ -ray spectrum.

The stone was examined with a Multispec combined LW/SW ultraviolet unit and fluoresced a strong chalky green to SW but remained inert to LW.

The inclusions were examined using a Bausch & Lomb Mark V Gemolite binocular microscope using dark field illumination or overhead lighting as appropriate. Polishing 'fire marks' were observed near facet junctions on the stone's crown and pavilion (Figure 3). Numerous blue-coloured pinpoint inclusions, some of which form 'phantom-like' fingerprints were observed under the

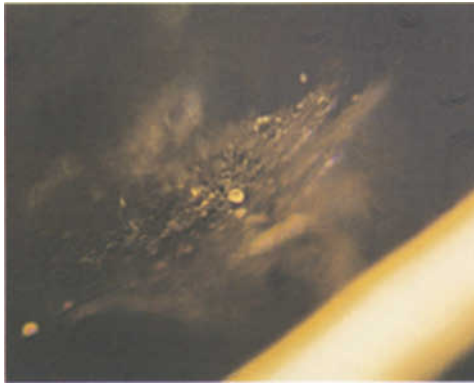

Figure 6: A small healed fracture containing glass-like and other material - probably undissolved dopant powder. 80 ×.

table facet (Figures 4 and 5). Also very near the surface towards the girdle, two small healed fractures are filled with a 'glass-like' substance, and solid material which may be undissolved alumina, titanium or iron (Figure 6). Large isolated perfectly spherical colourless gas bubbles are also present.

When the stone, immersed in methylene iodide, was examined in the optic axis direction between crossed polars, it showed two sets of straight twinning lamellae intersecting each other at 120° and 60° characteristic of the 'Plato striation', which betray Verneuil synthetics (Figure 7).

Broad, uneven, curved growth bands ranging from colourless to deep blue are

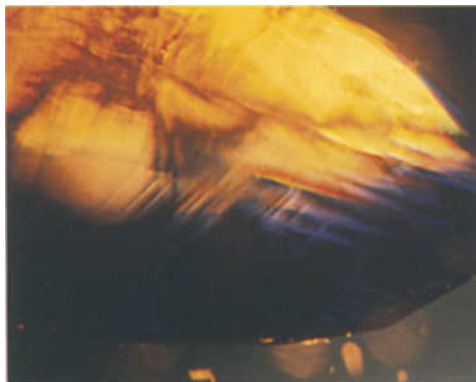

Figure 7: 'Plato striations' visible when looking at the stone parallel to the c-axis while immersed and between crossed polars. 15 ×.

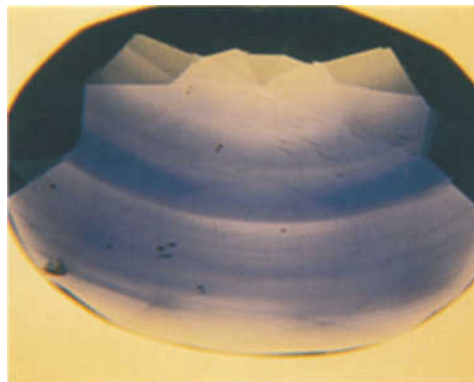

Figure 8: Curved colour bands visible with the stone immersed in xylol and using a different light source. 15 ×.

readily apparent parallel to the optic axis direction while the stone is immersed in liquid (Figure 8).

Discussion

In the Verneuil process, to obtain the blue colour of sapphire, titanium and iron dopants ($\pm 1.5\%$ Fe₂O₃ and $\pm 0.5\%$ TiO₂) are added to the alpha form of Al₂O₃. If most of the iron and titanium burns off in the furnace's intense heat, before these elements fuse, only sufficient Fe and Ti remain to produce the blue colour of sapphire⁽⁵⁾. Not enough iron remains to influence the spectrum. This is why the Verneuil synthetic sapphires lack the 450, 460 and 470 nm absorption lines typical of natural sapphires^(6, 7, 8, 9, 10).

Bearing this in mind, the stone was checked for diffusion treatment which could be responsible for the iron absorption spectrum observed.

- When examined in methylene iodide it did not appear as diffusion treated sapphires normally do: it did not show a colour concentration along the facet junctions; rather, the colour variations were not related to facet outline.
- The blue spherical inclusions of different pinpoint sizes, observed in abundance in this stone, must originate from some of the powders containing the trace elements iron and titanium, which had mixed unevenly, and had not been homogenized during burning. The high temperature necessary to produce the Verneuil synthetic sapphire began to melt the perhaps rather coarse powders containing the trace elements, and these interacted with one another (IVCT Fe²⁺→Ti⁴⁺) before fusing, causing accidental internal diffusion, resulting in the small blue halos⁽¹¹⁾ as observed in Figure 5.

Conclusion

The physical and optical properties are consistent with those of synthetic flame fusion synthetic corundum, variety synthetic sapphire.

The stone probably did not suffer a deliberate diffusion treatment, but an accidental internal diffusion. The internal diffusion of the trace elements iron and titanium that cause the blue haloes and the weak iron absorption line could be due to accidental over-heating of the stone in a furnace. There is a distinct possibility that the synthetic sapphire found its way into a batch of natural sapphires which were then subject to heat treatment.

References

1. Fritsch E., and Rossman G.R., 1988. An update on color in gems. Part 2: colors involving multiple atoms and color centers. *Gems & Gemology*, 24(1), 3-15
2. Schwarz, D., Petsch E.J., and Kanis J. 1996. Sapphires from the Andranondambo region, Madagascar. *Gems & Gemology*, 32(2), 93-4
3. Schmetzer K., and Bank H. 1980. Explanations of the absorption spectra of natural and synthetic Fe- and Ti-containing corundums. *Neues Jahrbuch für Mineralogie Abhandlungen*, 139, 216-25
4. Schmetzer K., and Kiefert, L., 1990. Spectroscopic evidence for heat treatment of blue sapphires from Sri Lanka - additional data. *Journal of Gemmology*, 22(2) 80-2
5. Webster, R., 1994. *Gems: their sources, descriptions and identification*. 5th edition, revised by Peter G. Read, Butterworth-Heinemann Ltd, Oxford, 402 and 407
6. Arem, J.E., 1987. *Color encyclopedia of gemstones*. Chapman & Hall, One Penn Plaza, New York NY 10119, 222
7. Liddicoat, R.T., 1989. *Handbook of gem identification*. 12th edition, 2nd revised printing. Gemological Institute of America, Santa Monica, CA, 91
8. Nassau, K., 1980. *Gems made by man*. Chilton Book Co., Radnor, Pennsylvania, USA, 149
9. Hughes, R.W., 1997. *Ruby and Sapphire*. RWH publishing, Boulder, Colorado, USA, 149
10. Herbert Smith, G.F., 1972. *Gemstones*. 14th edition, revised by F.C. Phillips, Chapman and Hall, London, 96, 290
11. Koivula, J.I., 1987. Internal diffusion. *Journal of Gemmology*, 20 (7-8), 474-7

A note on two star stones

R. R. Harding

Gem-A, 27 Greville Street, London EC1N 8TN

ABSTRACT: A polished cabochon of rutile of 16.57 ct engraved to display a star effect is described. The rutile contains significant Nb and Fe, and minor Ta, Sn and W, and its nomenclature is discussed. An unusual crystal of colourless beryl, variety goshenite, contains three zones of tiny inclusions which impart a distinct star effect, weak in some lighting conditions, but strong when lit at an angle by a single light source.

Rutile with a 13-ray imitation star

Recently the author obtained an opaque cabochon of 16.57 ct which displays a strong star when lit by a single source. The stone was described as rutile and the star was the result of artificial engraving (cf. McClure and Koivula, 2001; Schmetzer and Steinbach, 2002). The cabochon averages approximately 13.7 mm in diameter and 6.9 mm in thickness, and has an unpolished base.

The star effect is shown in *Figure 1* and at this angle, displays 13 rays, of which one is very short. At other angles, fewer rays are displayed and this inconsistency of appearance together with the unsymmetrical nature of a 13-ray pattern should prompt questions in the mind of any gemmologist about the origin of such a stone. In detail, the reflection of light in each ray of the star comes from minute closely-spaced parallel grooves on the cabochon surface. In natural star stones, the tiny acicular or tube inclusions commonly lie in two or three orientations quite close to each other, but in the engraved stars the grooves lie in one direction only for each arm.

The stone was sold in the trade as rutile, but opaque gems are not easy to identify by traditional gem testing methods and an

analysis was sought at the Natural History Museum. From a scanning electron microscope (SEM), images of the polished surface of the cabochon indicate that at least two phases are present – a host mineral and oriented inclusions or exsolution lamellae, some elongate and some platy in shape (*Figure 2*). An attached energy dispersive analytical system (EDS) on the SEM provided qualitative data indicating that both phases are oxides rich in titanium with variable contents of iron, niobium, tantalum, tin and manganese. The only clear difference between the host and inclusions appears to be the presence of up to 8% tungsten in the inclusions. Approximate compositions of

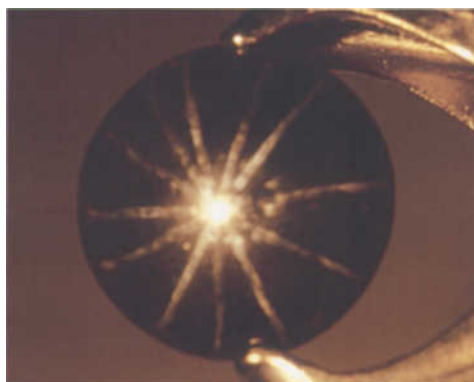

Figure 1: Rutile cabochon approximately 13.7 mm in diameter with artificial star.

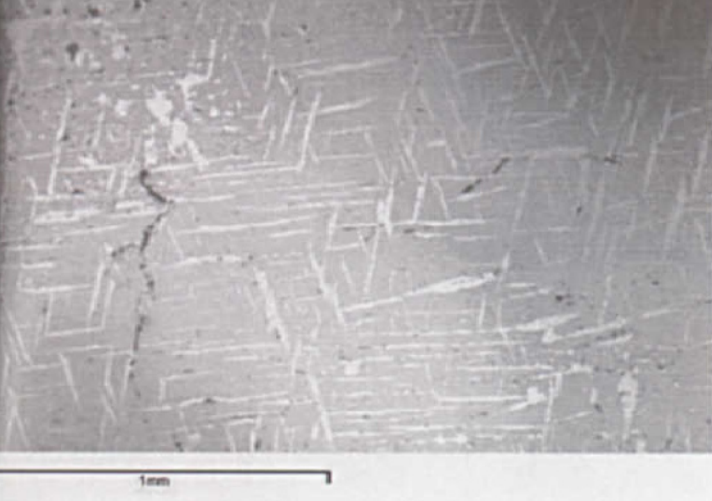

Figure 2: Detailed structure of mineral phases on the polished surface of the rutile cabochon. Back-scattered electron image showing the pale grey exsolution lamellae with a higher tungsten content than the darker host rutile. The scale bar is 1 mm. Photograph by J. Spratt.

two sample spots each of host and inclusion are given in *Table I*.

From *Table I*, it is apparent that titanium (Ti) comprises approximately half the cations and that niobium (Nb) is the next most

Table I: Compositions of sample spots of host mineral and exsolution lamellae in star rutile.

Element	Element content based on 4 cations and 8 oxygen atoms			
	Host mineral		Exsolution lamellae	
Ti	2.23	1.56	0.99	2.22
Mn	b.d.	b.d.	0.04	b.d.
Fe	0.63	0.86	1.00	0.61
Nb	0.93	1.35	1.62	0.89
Sn	0.03	0.04	0.02	0.06
Ta	0.17	0.19	0.14	0.16
W	b.d.	b.d.	0.18	0.06

b.d. = below detection

Analyst: J. Spratt, The Natural History Museum

abundant cation. The stone is therefore not a pure rutile – TiO_2 – as gemmologists have become familiar with it as inclusions in sapphire or ruby for example. However, in the mineral world, the rutile group comprises a number of multiple oxides containing Nb and Ta. Gaines *et al.* (1997, p.237) state: “Nb, coupled with Ta, Fe^{2+} and/or Fe^{3+} enters the composition of rutile up to a maximum of about 33% Nb_2O_5 ...” and “The point at which the Nb_2O_5 content justifies the name ilmenorutile rather than niobian rutile is arbitrary and not fixed ...”. So, in mineralogical terms, the stone would be called niobian rutile or ilmenorutile depending on what further comprehensive analyses revealed.

However, for gem trade purposes, the procedure for precisely naming complex minerals is often not economic and more general names have to be adopted. For the star stone described above, the analyses clearly indicate that it belongs to the rutile group, a vindication of the name given to it in the trade – and it is up to gemmologists to be aware that this rutile is not quite the same as the rutile one commonly sees as inclusions.

Star beryl

Recently a most unusual crystal was submitted by John Saul to the Laboratory for examination. It is a colourless beryl, variety goshenite, and was recovered about ten years ago from Lavra do Verdinho, Marilac, Minas Gerais, Brazil; its longest dimension, from 11 o'clock to 5 o'clock in *Figure 3*, is approximately 51.4 mm, and the height is approximately 43 mm and thickness 13.8 mm. The crystal displays approximately 36 faces of which the basal pinacoids and first order prisms are dominant; it is shown in *Figure 3* resting on a first order prism face.

The pinacoids are very smooth and allow a clear view of the internal features of the crystal. *Figures 3* and *4* show concentric growth features parallel to the first order prisms which distort transmitted light and cause a rippled effect. Curiously, this effect is more visible on film when the crystal is out



Figure 3: View parallel to the *c*-axis of a beryl crystal measuring approximately 49.5 mm across, 43 mm high and 13.8 mm thick. The crystal contains numerous inclusions and displays growth zones (seen as 'ripples') parallel to the prism faces.

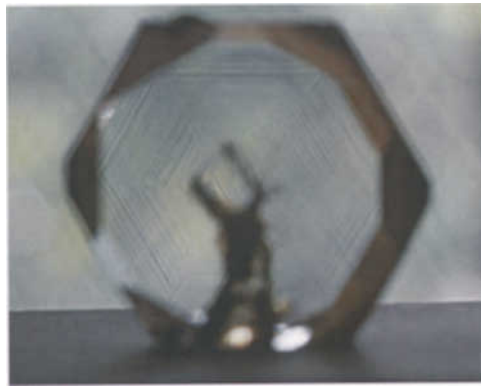

Figure 4: In this view, the concentric growth zones in the beryl crystal are visually emphasized at the expense of the focus of the crystal.

of focus (Figure 4). A complex fissure inclusion rises from the prism face at the bottom of the picture through the centre of the crystal and parts of it display iridescence (see Figures 5 and 6).

This is a spectacular beryl crystal by any standard, but its interest is enhanced further by the presence of bands of inclusions in the form of a six-rayed star (Figures 5 and 6). In Figure 5, a star with its arms perpendicular to the main prism faces is displayed and this rather weak degree of visibility obtains for many lighting conditions. Only when the crystal is correctly oriented in a strong directional light beam is a distinct star revealed – as in Figure 6.

According to Sinkankas (1981, p.194), "Asterism in beryls is extremely rare", and he subsequently describes the different kinds of chatoyancy and asterism found in the varieties of this species. Sinkankas (op. cit. p.195) states: "The few examples of asterism that have been recorded are due to three sets of inclusions, crossing mutually at angles of 60°, and lying in the plane at right angles to the *c*-axis." He draws a contrast between the "shimmering stars ... caused by reflections from numerous fibrous inclusions" and the "fixed star" of trapiche emeralds from Colombia caused mainly by narrow zones of dark inclusions. Another kind of asterism

found in aquamarine (also p.195) is due to minute grains of ilmenite or to pyrrhotite aligned on the basal planes in the beryl structure and producing a rather weak star.

The star in this Brazilian crystal is caused by bands of minute inclusions aligned in the

Figure 5: Beryl crystal viewed from the direction opposite to that in Figures 3 and 4 showing a band of fissures and solid inclusions in the lower centre, some iridescence in a fissure left of centre, and a star structure caused by abundant tiny round and elongated inclusions in three major zones. Small second order prism faces can be seen silhouetted at 3 o'clock, 9 o'clock and about 11 o'clock.



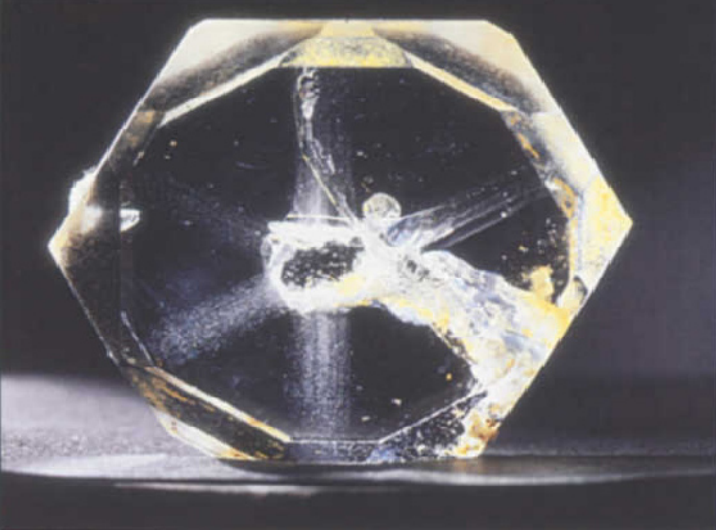

Figure 6: In favourable light, the star effect of the bands of inclusions is very marked. Iridescence is also visible to the right of centre.

basal plane perpendicular to the first order prism faces, and thus is consistent with the first kind of asterism described by Sinkankas. Within the bands the inclusions consist mainly of equidimensional grains or cavities with less abundant elongate or acicular grains oriented at low angles to the basal plane or to the c-axis. Most are between 10 and 100 μm long and some contain liquid and gas.

Acknowledgements

Thanks are due to E. Gamini Zoysa for supplying the imitation star rutile, to Dr J. Saul for loan of the beryl crystal, and to J. Spratt and P. Tandy of the Natural History Museum for providing microprobe and X-ray data and for interesting discussion.

References

- Gaines, R.V., Skinner, H.C.W., Foord, E.E., Mason, B., and Rosenzweig, A., 1997. *Dana's new mineralogy*. John Wiley and Sons Inc., New York
- McClure, S.F., and Koivula, J.J., 2001. A new method for imitating asterism. *Gems & Gemology*, 37(2), 124-8
- Schmetzer, K., and Steinbach, M.P., 2002. Fake asterism – two examples. *Journal of Gemmology*, 28(1), 41-2
- Sinkankas, J., 1981. *Emerald and other beryls*. Chilton Book Co., Radnor, Pennsylvania

Gem-quality spessartine-grossular garnet of intermediate composition from Madagascar

Dr Karl Schmetzer¹ and Dr Heinz-Jürgen Bernhardt²

1. Taubenweg 16, D-85238 Petershausen, Germany

2. Central Microprobe Facility, Ruhr-University, D-44780 Bochum, Germany

ABSTRACT: Gemmological, chemical and spectroscopic properties of a light yellowish-orange gem-quality garnet from Madagascar are reported. The sample is composed of 49 mol.% spessartine, 41 mol.% grossular, 5 mol.% almandine and 5 mol.% pyrope. A SG of 3.97 and a RI of 1.770 are in the range commonly observed for intermediate pyrope-almandine or pyrope-spessartine garnets. The colour of the spessartine-grossular garnet and its absorption spectrum are similar to that of low iron-bearing spessartine.

Introduction

Gem-quality natural garnets are considered as members of four major solid solution series, i.e. the three groups of the pyralspite series (pyrope-almandine, pyrope-spessartine, spessartine-almandine), and grossular-andradite (Stockton and Manson, 1985; Johnson *et al.*, 1995; Hanneman, 1997). Although natural intermediate garnets between grossular and members of the pyralspite series are known (see, e.g. Deer *et al.*, 1982), gem-quality grossular described so far forms only a limited solid solution with pyrope, almandine and spessartine. In general, the grossular component exceeds 75 molecular per cent in numerous chemical analyses (see e.g. Manson and Stockton, 1981; Stockton and Manson, 1982). In gem-quality spessartine, on the other hand, only minor molecular percentages of grossular are present (Laurs and Knox, 2001). In intermediate pyrope-spessartine garnets, the

molecular percentage of grossular only rarely exceeds 15 per cent (Jobbins *et al.*, 1978; Schmetzer and Bank, 1981; Stockton and Manson, 1982; Schmetzer *et al.*, 2001). An extraordinary pyrope-spessartine sample from Umba Valley, Tanzania, with a grossular percentage of 24% was described by Schmetzer (1982) and a sample with similar properties was mentioned by Bank and Henn (1989).

Intermediate pink to pinkish-orange pyrope-spessartine 'malaya' garnets from Bekily, Madagascar, were recently described by Schmetzer *et al.* (2001). In order to compare the chemical and spectroscopic properties of the Bekily samples with the properties of spessartines from Madagascar, 12 samples from unspecified locations in Madagascar were also analysed. These gemstones were selected from several parcels totalling about 200 spessartine and spessartine-almandine garnets in the yellowish-orange, orange, orange-brown, and brownish-red to almost red colour





Figure 1: Three spessartines (left) and three hessonites from Madagascar revealing an almost identical colour range. The hessonites range from 3.9 to 4.2 mm across. Photo by Maha Tannous.

range. These spessartine parcels also contained about 50 faceted grossulars (hessonites) of similar colours (Figure 1) and so five samples of this garnet variety were also chemically analysed. Surprisingly, the microprobe analyses revealed one sample with an extraordinary composition intermediate between spessartine and grossular (Figure 2), which is described below (for experimental details refer to Schmetzer *et al.*, 2001).

All garnet parcels mentioned above were bought by a German dealer within the last five years on various occasions in Madagascar and all samples had already been faceted in their country of origin. Therefore we are unable to indicate the exact locations of either the spessartine or the grossular garnets, or the locality for the intermediate spessartine-grossular sample.

Properties

Spessartines

Microprobe analyses revealed 34.7 – 39.1 wt.% MnO and 2.4 – 8.2 wt.% FeO. Traces of calcium were present (0.2 - 0.5 wt.% CaO) and MgO was below 0.05 wt.% in all samples. The chemical data indicate 80.4 –

93.2 molecular per cent spessartine and 5.5 – 18.9 molecular per cent almandine. Grossular ranges from 0.6 to 1.5 molecular per cent, and pyrope contents were approximately 0.1 molecular per cent. With increasing iron (i.e. almandine content), the colour changed from bright yellowish-orange or orange to orange-brown and almost red (see again Figure 1). Also, as iron contents increased, the RI and SG values increased from 1.800 to 1.808 and from 4.15 to 4.22 respectively.

Hessonites

Microprobe analyses revealed 36.5 – 36.8 wt.% CaO and 2.7 – 5.7 wt.% Fe₂O₃. Traces of manganese (0.05 – 0.2 wt.% MnO) and magnesium (0 – 0.6 wt.% MgO) were also present. The chemical data indicate 84.3 – 93.8 molecular per cent grossular and 6.0 – 15.5 molecular per cent andradite. Spessartine varies from 0.1 to 0.3 molecular per cent, and pyrope contents were between 0 and 0.6 molecular per cent. With increasing iron (i.e. andradite content), the colour changed from yellowish-orange or orange to orange-brown and reddish-brown (see again Figure 1). Also, as iron contents increased, the RI and SG values increased from 1.740 to 1.753 and from 3.61 to 3.67 respectively.

Description of the intermediate spessartine-grossular

Gemmological, chemical and spectroscopic properties of the 0.42 ct round, light yellowish-orange garnet sample from Madagascar are summarized in *Table I*. SG and RI values are intermediate between those commonly observed for natural spessartine and natural grossular (see, e.g., Stockton and Manson, 1985; Hanneman, 1997). Specifically, the values for SG and RI are in the range commonly observed for intermediate members of the pyrope-almandine and pyrope-spessartine series (Manson and Stockton, 1981; Stockton and Manson, 1982, 1985; Lind *et al.*, 1998; Schmetzer *et al.*, 2001). Microscopically, only a healing feather and some anomalous double refraction were observed as is commonly seen in garnet members of the pyralspite (pyrope-almandine-spessartine) series. Unfortunately, no mineral inclusions were present to indicate a possible paragenesis of the garnet sample.

Chemical data (see *Table I*) indicate a composition intermediate between spessartine and grossular with distinct contents of the almandine and pyrope molecules. A calculation of the garnet composition for 12 oxygens and for both Fe^{2+} and Fe^{3+} , indicates the presence of a small amount of Fe^{3+} in the range of 0.5 molecular percentage of the andradite end member. Only traces of vanadium and chromium are present.

Spectroscopic examinations reveal an absorption spectrum almost identical to that of low iron-bearing spessartine, e.g. from Namibia, Nigeria or California (Lind *et al.*, 1993; Milisenda and Zang, 1999; Lind and Henn, 2000; Laurs and Knox, 2001). Thus, the assignment of absorption bands is consistent with that of other members of the pyrope-spessartine and spessartine-almandine series with low iron contents (for details of the assignment, see also Schmetzer *et al.*, 2001). Consequently, the colour of the sample is comparable with the colour of low iron-bearing spessartine, e.g. with the colour of



Figure 2: Intermediate spessartine-grossular from Madagascar. Diameter of the sample 4.4mm. Photo by Maha Tannous.

some of our spessartine samples from Madagascar with iron contents in the range of 2 – 3 wt.% FeO.

Discussion

The properties of the spessartines and the hessonites from Madagascar are those commonly observed for these varieties of gem-quality garnets, i.e. for members of the spessartine-almandine or of the grossular-andradite series. So far, the intermediate spessartine-grossular is a unique sample, and further garnets that might be of similar composition were not found within the lots from Madagascar available to us (e.g. by a routine determination of the RI of garnet samples with similar coloration).

The composition of the spessartine-grossular from Madagascar is intermediate between two non-gem-quality garnets reported by Deer *et al.* (1982), i.e. between sample 28 of *Table 56* with 33 mol.% grossular and 51 mol.% spessartine and sample 17 of *Table 58* with 58 mol.% grossular and 36 mol.% spessartine.

The distinction of intermediate spessartine-grossular garnet from spessartine or grossular (hessonite) is possible by comparison of physical properties, especially by the determination

Table I: Properties of an intermediate spessartine-grossular garnet from Madagascar.

Gemmological properties		Chemical properties		Spectroscopic properties	
		Microprobe analysis (wt.%) ^a	Cations based on 12 oxygens	Absorption maxima (nm) intensity ^c	Assignment
Weight	0.42 ct	SiO ₂ 37.88	Si 2.990	687 medium	Fe ²⁺
Size	4.4 mm round	TiO ₂ 0.15	Ti 0.009	610 weak	Fe ²⁺
Colour	Light yellowish-orange	Al ₂ O ₃ 21.39	Al 1.989	569 very weak	Fe ²⁺
SG	3.97	Cr ₂ O ₃ 0.02	Cr 0.001	525 strong	Fe ²⁺ /Mn ²⁺
		V ₂ O ₃ 0.04	V 0.003	503 medium	Fe ²⁺
RI	1.770	FeO ^b 2.37	Fe 0.156	483 very strong	Mn ²⁺
Microscopic features	Healing feather Anomalous double refraction	MnO 21.91	Mn 1.464	459 very strong	Fe ²⁺ /Mn ²⁺
		MgO 1.36	Mg 0.160	430 strong	Mn ²⁺
		CaO 14.58	Ca 1.233	421 strong	Mn ²⁺
		Total 99.70		410 very strong	Mn ²⁺
		Mol.% end members	Almandine 5.18 Spessartine 48.59 Pyrope 5.31 Grossular 40.92		

Notes: ^a Mean of 10 analyses

^b total iron as FeO

^c Intensity is qualitatively assessed from weak to very strong

of SG and RI. The distinction from intermediate members of the pyrope-almandine or pyrope-spessartine series is, so far, performable on the basis of colour and spectroscopic properties. An overlap of gemmological features, however, may be expected if more intermediate samples within the complete grossular-spessartine series are found and particularly if the samples have different contents of colour-causing trace elements, e.g. with

somewhat higher iron, vanadium or chromium contents.

References

- Bank, H., and Henn, U., 1989. Ein ungewöhnlicher Granat aus Ostafrika. *Zeitschrift der Deutschen Gemmologischen Gesellschaft*, **38** (4), 161-4
- Deer, W.A., Howie, R.A., and Zussman, J., 1982. *Rock-forming minerals. Volume 1A, orthosilicates, second edition*. Longman, London and New York
- Hanneman, W. Wm., 1997. A unified system for classifying garnets. *Journal of Gemmology*, **25** (7), 471-3

- Jobbins, E.A., Saul, J.M., Statham, P.M., and Young, B.R., 1978. Studies of a gem garnet suite from Umba river, Tanzania. *Journal of Gemmology*, **16** (3), 161-71
- Johnson, M.L., Boehm, E., Krupp, H., Zang, J.W., and Kammerling, R.C., 1995. Gem-quality grossular-andradite: a new garnet from Mali. *Gems & Gemology*, **31** (3), 152-66
- Laurs, B.M., and Knox, K., 2001. Spessartine garnet from Ramona, San Diego County, California. *Gems & Gemology*, **37** (4), 278-95
- Lind, Th., Bank, H., and Henn, U., 1993. Spessartine aus Namibia. *Neues Jahrbuch für Mineralogie Monatshefte*, 1993 (12), 569-76
- Lind, Th., and Henn, U., 2000. A new find of spessartine garnets in Nigeria. *Journal of Gemmology*, **27** (3), 129-32
- Lind, Th., Henn, U., and Milisenda, C.C., 1998. Vergleichende Untersuchungen an Rhodolithen verschiedener Provenienz. *Gemmologie, Zeitschrift der Deutschen Gemmologischen Gesellschaft*, **47** (1), 53-9
- Manson, D.V., and Stockton, C.M., 1981. Gem garnets in the red-to-violet color range. *Gems & Gemology*, **17** (4), 191-204
- Manson, D.V., and Stockton, C.M., 1982. Gem-quality grossular garnets. *Gems & Gemology*, **18** (4), 204-13
- Milisenda, C.C., and Zang, J., 1999. Spessartine aus Nigeria. *Gemmologie, Zeitschrift der Deutschen Gemmologischen Gesellschaft*, **48** (4), 223-6
- Schmetzer, K., 1982. An unusual garnet from Umba Valley, Tanzania. *Journal of Gemmology*, **18** (3), 194-200
- Schmetzer, K., and Bank, H., 1981. Garnets from Umba Valley, Tanzania - members of the solid solution series pyrope-spessartine. *Neues Jahrbuch für Mineralogie Monatshefte*, 1981 (8), 349-54
- Schmetzer, K., Hainschwang, T., Kiefert, L., and Bernhardt, H.-J., 2001. Pink to pinkish-orange malaya garnets from Bekily, Madagascar. *Gems & Gemology*, **37** (4), 296-308
- Stockton, C.M., and Manson, D.V., 1982. Gem garnets: the orange to red-orange color range. In: Eash, D.M. (Ed.), *International Gemological Symposium Proceedings 1982*. Gemological Institute of America, Santa Monica, CA, 327-38
- Stockton, C.M., and Manson, D.V., 1985. A proposed new classification for gem-quality garnets. *Gems & Gemology*, **21** (4), 205-18

Letter to the Editor

Rare Gemstones: Chondrodite

After the appearance of our article (Zwaan and Zoysa, 2002) Willow Wight kindly sent me some additional information on another locality where gem-quality chondrodite was found, but which was not mentioned in our article. Apart from the mentioned localities, such as the Tilly Foster mine, near Brewster, New York, and Pargas and Kafveltorp in Sweden, the Cameron quarry, about 45 km west of Ottawa, near Carlton Place, Lanark County, Ontario, has also produced some very small gem-quality chondrodites. A bright orange-yellow

faceted chondrodite of 0.25 ct was reported from this mine by Wight (1998).

Hanco Zwaan

National Museum of Natural History
Leiden, The Netherlands

References

- Zwaan, J.C., and Zoysa, G., 2002. Gem-quality chondrodite from Balangoda, Sri Lanka. *The Journal of Gemmology*, **28**(3), 162-8
- Wight, W., 1998. Check-list for rare gemstones: chondrodite. *The Canadian Gemmologist*, **XIX** (4), 111

Proceedings of the Gemmological Association and Gem Testing Laboratory of Great Britain and Notices

OBITUARY

It is with great sadness that we report the death of **Richard T. Liddicoat**, Chairman of the Gemological Institute of America and Honorary Fellow of Gem-A on 23 July. A personal tribute by David Callaghan follows.

Richard 'Dick' T. Liddicoat Jr

A personal tribute

It doesn't need me to write of the achievements of this consummate gemmologist: there are others far more qualified and capable than I am that have done so. However, there are many people who never met 'Dick'. It is to those of you that I address this tribute in the hope that I can give you a picture of this remarkable man.

Let me ask you to allow your mind to conjure up a picture of the person you would like to have as a favourite uncle. He will need to possess at least one of the following attributes: a warm smile; a welcoming handshake; a comforting voice; a sense of humour – perhaps occasionally a teasing humour; the ability to make you feel at home; the kindness of manner to make you feel that you have his whole attention. The 'uncle' I hope to introduce had all these attributes. That is rare indeed.

I first met Dick during a visit to GIA's New York Lab in 1980. Having been elected Chairman of the Gemmological Association of Great Britain I had introduced myself to the late Eunice Miles and to 'Bob' Crowningshield. Whenever my work took me to New York they made me very welcome and it was on one of my visits that I was introduced to Dick. His admiration of the work of the GA, and of his great friend B.W.Anderson was made very

clear to me. He, like Basil Anderson, greatly respected the dealers in the trade.

In 1981, during the Golden Jubilee celebrations of the GA, he joined B.W. Anderson, Dr E. Gübelin and 'Bob' Crowningshield in London as guest lecturers. It was at this time that he was given the Honorary Fellowship of the GA, an honour of which he was very proud. So much so that, whenever he knew he and I were scheduled to meet somewhere, he would always pointedly wear his GA necktie!

He was naturally a polite man and did not take offence easily. An example of this came about during that 1981 visit to London. My wife and I invited him to join us for lunch on Sunday and we decided to take him to a restaurant in Windsor. We duly collected him from the Royal Lancaster Hotel and over lunch we talked of family matters and the like. In telling us of his upbringing in his Michigan hometown he expressed disappointment that he was not able to go home as often as he would like. He told us of his elderly father, now over 90, and we asked, ingenuously and perhaps patronisingly, "Who looks after your father?" To our astonishment he replied, "My mother!" She was also over 90. He took no offence at the implication behind our question that he, Dick, looked older than he was!

I was also a victim of his impish humour on more than one occasion. One was in 1985 when I attended the ICA Conference in Idar-Oberstein in my capacity as Gemmological Association Chairman. I was due to leave the Conference before the close and faced an awkward train journey to Frankfurt. As I was checking out of the hotel Dick saw me and said I would be very welcome to

accompany him by car. He, Glenn Nord and the late Vince Manson were to drive there. He brushed aside my gentle protests saying there would be no problem and I would be very welcome. I had not met Glenn Nord at the time nor did I know Vince Manson. Throughout the two hour journey Glenn seemed quietly bemused at my presence and Vince was pre-occupied with driving. I discovered later that Dick had told them that I was "a very quiet sort of guy"; those of you who know me will certify that it is impossible for me to keep quiet for the whole two hours of a car journey!!

As I sit compiling this tribute I have in front of me a photograph of Dick in an off-duty moment. Also in the photograph is my great friend the late Eric Bruton of whom Dick was very fond. Dick does not look like a man to have a species of tourmaline named after him, one with a long and complicated chemical formula completely incomprehensible to me!

His contribution to gemmology is immense and enduring. An artist could give you an accurate painting of the man – but I am no artist. I may be accused of being facetious when I say that, in his appearance, he reminded me of the great American screen actor E.G. Marshall combined with Jack Benney. The first because of his obvious sincerity and integrity – the other for his rich voice and the smile that leads you to think of some gentle mischief in the making!



Richard Liddicoat at the Presentation of Awards held on 28 October 1985 at Goldsmiths' Hall, London.

GIFTS TO THE ASSOCIATION

The Association is most grateful to the following for their gifts for research and teaching purposes:

Bronwen Fraser of Christiana, South Africa, for an oxidized diamond, and samples of kimberlite and alluvial gravel 'batontoms'.

Charles Green & Son Ltd., Birmingham, for a selection of gemstones.

Ian Thomson of Thomson Gems Ltd., London, for a large selection of gemstones for use in education.

He kindly wrote a personal dedication in the flyleaf of a copy of his *Handbook of Gem Identification* and I treasure his words to me. Those of us who had the privilege of knowing Dick have had our lives enriched. We are thus the poorer in the knowledge that he is no longer with us.

* * *

Trevor M. Brook FGA (D.1953 with Distinction), Leicester, died suddenly on 10 July 2002.

MEMBERS' MEETINGS

London

On 25 September 2002 at 27 Greville Street, London EC1N 8TN the Annual General Meeting was held, a report of which will be published in the January 2003 issue of *The Journal*. The AGM

was followed by a talk by Stephen Kennedy entitled 'Notes from the Laboratory: detection, disclosure and false descriptions'.

Midlands Branch

On 27 September at The Earth Sciences Building, University of Birmingham, Edgbaston, Richard Taylor gave a talk on 'Diamonds certification, appraisal and valuation'.

North West Branch

On 18 September at Church House, Hanover Street, Liverpool 1, John Harris gave a talk entitled 'Chasing rainbows'.

Scottish Branch

Two talks were given on 4 September at the British Geological Survey, Murchison House, West Mains Road, Edinburgh. Dr Lin Sutherland spoke on 'New developments in dating gem corundum sources below basaltic gemfields' followed by Dr Rui Galopim de Carvalho with a talk entitled 'The Portuguese Crown Jewels'.

ANNUAL REPORT

The following is the Report of the Council of Management of the Gemmological Association and Gem Testing Laboratory of Great Britain for the period 1 January 2001 to 31 March 2002.

Officers, councils and committees

The Gemmological Association and Gem Testing Laboratory of Great Britain (GAGTL) is a company limited by guarantee and is governed by the Council of Management. With decreasing involvement in the day-to-day activities of the Association, N.W. Deeks resigned from the Council of Management in July but agreed to the unanimous wish of the Council that he become a Vice President. In November, J-P. van Doren left his post as Chief Executive Officer and resigned from the Council, and Council wishes to thank him for his contribution towards raising the visibility of the Association worldwide. Following the departure of J-P. van Doren, Council appointed Council member T.M.J. Davidson, FGA, as acting CEO. The President, Professor A.T. Collins, continued in office as did Vice Presidents A.E. Farn, R.A. Howie, D.G. Kent and R.K. Mitchell. C.M. Woodward and E. Stern continued as

Chairman and Vice-Chairman respectively of the Board of Examiners. At the July meeting of the Trade Liaison Committee, J. Monnickendam completed a two-year term of office as chairman and handed over to J. Kessler; W. Roberts was elected Vice-Chairman of the committee. C. Winter (chairman) and P. Dwyer-Hickey (Vice-Chairman) continued in office on the Members' Council. At the Annual General Meeting in June, S. Burgoyne was elected to the Members' Council and A. Good stepped down after serving for three years - for which she is warmly thanked.

Education

During the two academic years straddled by this report, both the regular gemmology and gem diamond courses were full, with students coming from many different countries. The teaching is shared between Association staff and independent practitioners in the jewellery trade, and Council thanks all for their commitment and dedication. New Gemmology Diploma Course Notes and a new Practical Handbook were completed and brought into use at the beginning of the autumn term in 2001, and work on a foundation course in gems commenced.

A wide variety of short courses and tutorials was held at the Gem Tutorial Centre in Greville Street, and although sadly M. Keating left to further her jewellery career in Ireland, R. Warner joined us and has continued to develop the programme. D. Garrod has also developed his programme of customized tutorials for firms in the jewellery trade throughout the UK and participated in a training video for one firm. He also ran five half-day courses for the British Jewellers' Association.

A new Allied Teaching Centre (ATC) was established in Bangkok, Thailand, and the one in Jaipur, India, was re-established. Further expansion in Japan and Taiwan is under discussion.

This report covers three examination sessions, and a total of 1067 students sat the gemmology or gem diamond papers. In gemmology, the pass rate for the Preliminary examination was 81%, which is better than normal; the Diploma pass rate was 46%. In the Gem Diamond examination, 67% of candidates were successful.

The Presentation of Awards was again held at Goldsmiths' Hall where the President, Professor A. Collins, presided and welcomed the successful students and their families. He introduced the Guest of Honour, R. Sancroft-Baker, FGA, Senior Director of the Jewellery Department at Christie's, who presented diplomas to the successful students and also announced the following prizes: the Preliminary Trade Prize to Mrs Karen McKinley, Abington, Northampton, England; the Anderson Medal to P. Bick San Wong of Hong Kong; the Christie's Prize for Gemmology to I. Sipson of Trowbridge, Wiltshire; the Anderson-Bank Prize to Dong Lan of Wuhan, China; and the Deeks Diamond Prize to A. Thomas of Birmingham, West Midlands. In the opinion of the Examiners no student submitted papers of sufficient quality to be awarded either the Tully or Bruton medals.

The Board of Examiners met three times under its Chairman, C.M. Woodward. On the recommendation of the Board, Li Liping of Wuhan, China, was appointed a Gem Diamond Practical Examiner by the Council of Management, and the Board also approved the introduction of a practical element into the Preliminary course. Council very much appreciates the contributions of all the examiners in maintaining and developing the Association's qualifications, and also thanks B. Hunt and L. Dean for their dedication and resourcefulness.

The Education Review Meeting was held as usual in November and provided a valuable forum for the direct exchange of views between tutors, lecturers, examiners and staff of the education department. Details of course content, ways of introducing practical instruction and marking schemes were discussed.

In November I.F. Mercer and J-P. van Doren travelled to Shanghai for talks with the China Diamond Promotion Service and the British Council and both delivered lectures at the Wuhan Gemmological Institute of China (GIC) Tenth Anniversary Conference and the Gemmological Association of Hong Kong jewellery conference in Hong Kong.

After government changes in the regulations dealing with approval of qualifications in the UK, the Association, through meetings and completion

of paperwork, fulfilled the requirements of the Qualifications and Curriculum Authority (QCA) to maintain the accreditation of the Diploma in Gemmology.

After holding office for four years, the Secretariat of the Federation for European Education in Gemmology (FEEG) passed from Gem-A to the Dutch Gemmological Association in 2001. I.F. Mercer serves on the Examination Committee of FEEG and attended the annual meeting in January 2002 held in Vicenza, Italy.

Laboratory

Diamond grading in the Laboratory continues to grow and provides a major part of Laboratory income. Increased numbers of coloured stones were also examined and there is a growing demand for opinions on whether stones have undergone heat treatment.

S.J. Kennedy and S. Kimber represented the Laboratory in 2001 at the Gem Industry and Laboratory Conference (GILC) in Tucson, USA. S.J. Kennedy attended the CIBJO annual meetings in Paris (2001) and Munich (2002), at which further meetings of the GILC were also convened. 'Notes from the Laboratory' were published in the January and October 2001 issues of *The Journal of Gemmology* and short accounts of laboratory activities have been published in jewellery trade magazines.

The Laboratory's international reputation was a major factor in securing a consultancy for a major project undertaken by a state in the Middle East and this will involve supply of equipment and training of staff.

Gem-A

On taking office as CEO in January 2001, J-P. van Doren held regular meetings with staff and others to work towards a new image for the Association. Designs were considered and by April, one had been selected. Gem-A was launched at a reception following the AGM in June 2001 and has since won general approval as a trading image. The new style was introduced to members, the trade and to the public at trade fairs and at 'Open Days' held in London and Birmingham.

Trade Fairs

In 2001 I.F. Mercer and S. Kimber ran a show stand at the American Gem Trade Association (AGTA) Show in Tucson, Arizona; in 2002, D.J. Garrod accompanied I.F. Mercer at Tucson, and for both shows grateful thanks are expressed to C. Balzan of San Francisco for his generous support. T.M.J. Davidson also supported the Association effort in 2002 and he took positive steps towards setting up a presence in the USA under the name 'Gem-A USA'. This will be a subsidiary company of GAGTL and Anne Dale has agreed to be the Director.

The Association also exhibited at four other major fairs during 2001: the NEC, Birmingham, in February, Las Vegas, Nevada, in June, and the International Jewellery London (IJL) and the Hong Kong Gem and Jewellery Fair in September. Gemmology was brought to a different audience with the Association's presence at four Rock 'n' Gem shows at Kempton Park, where the many enquiries for courses, books, instruments and membership are handled by A.J. Clark, D.J. Garrod and L.F. Stather.

Visits

In April 2001 the seventh annual visit to Idar-Oberstein was organized by S. Kimber and was enjoyed by over 40 participants who appreciated the warm welcome at all the venues they visited – the mine, the museums, the private collections and the gem-cutting workshops.

Visits closer to home were organized for members to the Diamond Trading Company (DTC) and the Mineral Gallery at the Natural History Museum, South Kensington.

Membership

Overall membership declined slightly with recruitment (mainly from educational courses) just failing to compensate for losses. The fall in Laboratory membership reflects a trend in the jewellery trade in which numerous small firms are giving away to fewer larger organisations.

Activity in the Branches continues to grow. The Midlands Branch held 14 meetings and celebrated their 50th anniversary at a weekend conference with guest speakers E.A. Jobbins, Prof. Dr H. Hänni and I.F. Mercer, with contributions by A.D.

Morgan and T.M.J. Davidson. The North West and Scottish Branches both held eight meetings and the latter ran an excellent conference in Perth with Richard Drucker the main speaker. The inaugural meeting of the South West Branch was held in January 2001 and although meetings have been fewer, attendances have been good – members travelling from Devon and South Wales.

In London, a varied programme of 10 lectures was held, including a double presentation by Dr Kurt Nassau, and again the Annual Conference was held at the Barbican Centre. The keynote speaker was G. Bosshart of the Gubelin Gem Laboratory who talked about diamonds and ruby treatments, Dr S. Lawson of the DTC talked about screening of treated diamonds, S. Whittaker (of Fellows Auctioneers) and H. Milton (Miltons, Liverpool Ltd) then gave a stimulating view of the pawnbroking and auction aspects of the trade, and T.M.J. Davidson looked at some aspects of 'Who or what is a jeweller?'

Publications

In the period January 2001 to March 2002, 26 papers were published in *The Journal of Gemmology* with topics ranging from Madagascan and Peruvian gemstones to jades and ornamental granite, and from fake asterism to the reasons for colour in diamond. Abstracts totalled 285 and there were 47 book reviews, and again, thanks go to M.J. O'Donoghue, to our abstractors and to the Mineralogical Society for permission to reproduce abstracts of possible relevance to the gem world. Council would also like to thank the Assistant Editors and the Production Editor, M.A. Burland, for their invaluable support, and a special acknowledgement is due to R. Coleman (of Harley UK) for his intense involvement in designing fresh and interesting Journal covers and in monitoring production.

Gem and Jewellery News is published jointly with the Society of Jewellery Historians and in 2001-2 contained a wide range of lecture and exhibition reviews, comments on new books, reports of activities at the branch events, the Gem Discovery Club highlights, and the often-quoted column 'Around the Trade' by H. Levy. As with *The Journal*, design is important, and a fresh look (again designed by R. Coleman) and expansion to 20 pages were introduced for Volume 11.

Photographic competition

The 2001 competition on the theme 'Born yesterday' drew entries of a high standard. The judges are independent of Gem-A and they selected three prizewinners and several more images to grace the calendar for 2002 which is distributed free to members. The winner was Marc de Regt of the Netherlands and he received his prize at the Reunion of Members in June. Council is most grateful to Harley UK, producers of *The Journal of Gemmology* for their sponsorship of these prizes and for their contribution to Annual Conference expenses.

Finance

Although there have been regular updates in recent years, the Association's computer system, installed in 1990-1, needed replacement. Installation of a new accounts package proved more complex than originally thought and after discussion with our accountants, Hazlems Fenton, Council decided to change the account reference period to terminate on 31 March rather than 31 December.

The financial result for Gem-A for the 15 month period to 31 March 2002 is a loss of £62,124. This compares with a surplus for 2000 of £22,384 and comes after considerable initiatives in launching Gem-A and promoting the Association at selected venues, particularly overseas.

Gemmological Instruments Limited

Gemmological Instruments Limited is a wholly-owned subsidiary company of GAGTL. It supplies good-quality gem testing equipment at keen prices and there is a constant search for improvement in performance and alternative sourcing of components by its executive director, A.J. Clark. Advances introduced in 2001-2 include a widefield dichroscope, a new version of the gemmologist's refractometer with a widefield eyepiece in secure housing, and thermal diamond testers available at much lower prices than previously. Although new gem books regularly appear on the market it is worth commenting that of the standard works used for teaching, Webster's *Gems* is becoming out of date, Bruton's *Diamonds* is out of date and out of print, as is Anderson's *Gem Testing*. With increased costs, there was an overall loss during the period of £14,039, and improved profitability is being sought with reviews of stock

and assessment of the various instrument and book ranges.

The staff and supporters

The period under review has been one of change and financial constraints have meant that many good ideas remain to be implemented. Nevertheless the staff have participated and given their full support to the actions initiated and the Council of Management thanks them for their positive attitude. This attitude carried through to support the new acting Chief Executive Officer, T.M.J. Davidson, whose first action was to draw up a Corporate Plan for the next three years. This was completed in March and has been presented to major bodies in the UK jewellery trade.

The Council of Management recognizes the wide extent of general goodwill towards the Association and would particularly like to thank those generous donors who have augmented our teaching collections and those who have given their time in furthering the positive work of the committees.

GEM DIAMOND EXAMINATION

In the Gem Diamond Examination held in June 2002, 102 candidates sat of whom 73 qualified, including seven with Distinction and eleven with Merit.

The **Deeks Diamond Prize** for the best candidate of the year in the Gem Diamond Examinations has been awarded to Julian Read of Goole, East Yorkshire.

The **Bruton Medal** was not awarded.

The names of the successful candidates are listed below:

Qualified with Distinction

Dimmick, Helen M., Pinner, Middlesex
Joshirao, Ajey A., Maharashtra, India
Li Yaoyao, Wuhan, Hubei, P.R. China
Wakefield, Dominic, Horsham, West Sussex
Warner, Rachel F., London
Yuling Mao, Wuhan, Hubei, P.R. China
Zhang Tao, Beidajie, Beijing, P.R. China

Qualified with Merit

Avery, Hilary E., Bangor, Co. Down, N. Ireland
Borruso, Alessandro, Harrow, Middlesex
Clark, Antony, Bolton, Greater Manchester
Corcoran, Moya A.M., London

Croucher, Nicola, London
Cruse, Suzanne, Wickford, Essex
Getgood, Fiona J., St Leonards on Sea, East Sussex
Plant, Monika, Knutsford, Cheshire
Taylor, Andrew, Basingstoke, Hampshire
Toullie, Nathalie, Brentford, Middlesex
Weidong Niu, Wuhan, Hubei, P.R. China

Qualified

Abimbola, Adedapo, Clapham South, London
Anderson, Ian, Heaton, Bradford, West Yorkshire
Arjan, Anand, East Ham, London
Balls, Serra, London
Baskerville, Fenella J., Upper Holloway, London
Besli, Selim, Hackney, London
Bryant, Susan, Sutton Coldfield, West Midlands
Burton, Lola C., Hastings, East Sussex
Callaway, Heather, Stone, Staffordshire
Cheadle, Sonia, Dalston, London
Collins, Steven J.C., Letchworth, Hertfordshire
Daswani, Vijayeta, St Johns Wood, London
Donnelly, Lee-ona F., Heathfield, Ayr, Scotland
Droujinina, Highgate, London
Forbes-McCaig, Charlotte, Newtownabbey,
Belfast, N. Ireland
Formosis, Dimitris, Athens, Greece
Fraser, Bronwen C., Christiana, South Africa
Greenstein, Saul, London
Greer, Paul F., Chatham, Kent
Hassan, Fatima, Totteridge, London
Hui Yee-Wan, Elsie, Kowloon, Hong Kong
Kam Ka Wai, Hong Kong
Leader, Lucille, London
Loaker, Alistair, Stevenage, Hertfordshire
Macrae, Margaret, Isle of Lewis, Scotland
McLeod, Fiona J., Yellowknife, North West
Territories, Canada
Matharu, Rajinder, Handsworth Wood,
Birmingham, West Midlands
Oh Minkyung, Busan, South Korea
Oshida, Reiko, Singapore
Pace, Howard M., Eccleshall, Stafford
Paraskevopoulos, Michael, Athens, Greece
Pearson, Heather A., Belper, Derbyshire
Quilley, Claire J.A., Aylesbury, Buckinghamshire
Rweyamamu, Edward J., Leytonstone, London
St John Lewis, Delyth, Palmers Green, London
Salukvadze, Iamze, Dubai, United Arab Emirates
Selvamani, Parvathi, Poplar, London
Shah, Monica, Cheadle, Cheshire

Sinclair, Harvey, Hendon, London
Stevens, Jill, Stonnall, Lichfield, Staffordshire
Sutton, Janine R., Harborne, Birmingham, West
Midlands
Tam Lai Fong, Betty, Kowloon, Hong Kong
Taylor-Leigh, Susan J., Kings Heath, Birmingham,
West Midlands
Tong Chi Cheung, Kowloon, Hong Kong
Tong Tong, Beidajie, Beijing, P.R. China
Tuckwell, Alice E., Untersigenthal, Switzerland
Varnava, Sofia, Polihmi, Thessaloniki, Greece
Verganelakis, Vassilis, Athens, Greece
Wang Ying, Beidajie, Beijing, P.R. China
Wagh, Elizabeth S., Rochford, Essex
Wong Sze Chai, Kowloon, Hong Kong
Xu Yuehong, Beidajie, Beijing, P.R. China
Yen Kwan, Humphrey, Hong Kong
Zhang Yaqiong, Beidajie, Beijing, P.R. China
Zhou Hao, Beidajie, Beijing, P.R. China

EXAMINATIONS IN GEMMOLOGY

In the Examinations in Gemmology held worldwide in June 2002, 222 candidates sat the Diploma Examination of whom 121 qualified, including three with Distinction and eleven with Merit. In the Preliminary Examination, 157 candidates sat of whom 125 qualified.

The **Anderson Bank Prize** for the best non-trade candidate of the year in the Diploma Examination has been awarded to Sally Hudson of London.

The **Christie's Prize for Gemmology** for the best candidate of the year in the Diploma Examination who derives his/her main income from activities essentially connected with the jewellery trade has been awarded to Nilmini Liyana Arachchige of Kandy, Sri Lanka.

The **Anderson Medal** for the best candidate of the year in the Preliminary Examination has been awarded to Neha Sehgal of New Delhi, India.

The **Preliminary Trade Prize** for the best candidate of the year who derives his/her main income from activities essentially connected with the jewellery trade has been awarded to Avneet Verma of New Delhi, India.

The **Tully Medal** was not awarded.

The names of the successful candidates are listed below:

Diploma

Qualified with Distinction

Liyana Arachchige, Nilmini S., Kandy, Sri Lanka
Morel, Francine, Ville Mont Royal, Quebec,
Canada
Sehgal, Neha, New Delhi, India

Qualified with Merit

Ashida, Eisuke, Kyoto City, Kyoto, Japan
Berry, Susan, London
Every, Susanne, London
Goumaz, Benoit, Geneva, Switzerland
Lacasse, Marie-Elise, Westmount, Quebec, Canada
Suetters, Brigitta M.T.H., Aalsmeer, The
Netherlands
Tiyu Duan, Wuhan, Hubei, P.R. China
Towers, Jill S., St Heliers, Auckland, New Zealand
Yi Zhou, Wuhan, Hubei, P.R. China
Zhu Xulei, Guilin, Guangxi, P.R. China
Zixi He, Wuhan, Hubei, P.R. China

Qualified

Agarwal, Vibha, New Delhi, India
Asano, Yoko, Gifu City, Gifu Pref., Japan
Aubert, Rebecca L., London
Aung Toe, Yangon, Myanmar
Aye Tin Tin, Yangon, Myanmar
Balzan, Patrick A., San Francisco, California, U.S.A.
Balzan, Robert A., San Francisco, California, U.S.A.
Bertrand, Sylvia, Barcelona, Spain
Blanshard, Ruth H., Devizes, Wiltshire
Bruls, Irene C.W., Maastricht, The Netherlands
Cai Xiaolin, Shanghai, P.R. China
Chan Miu Ching, Lavinia, Hong Kong
Cheng Wai Yee, New Territories, Hong Kong
Cheung Fung Wan, Happy Valley, Hong Kong
Chohan, Tarun, Putnoe, Bedfordshire
Choi, Daeshik, Wimbledon Park, London
Chookruvong, Kanjana, Bangkok, Thailand
Choudhary, Gagan, Jaipur, India
Chun Wen, Wuhan, Hubei, P.R. China
Cristol, Agata, Marseille, France
Dongjian Hu, Wuhan, Hubei, P.R. China
Dorrell, Clare G., Perth, Scotland
Falnes, Lene, Hafersjord, Norway
Fujimoto, Akiko, Kotu City, Yamanashi Pref., Japan
Govindarajulu, Suresh, St Johns, Antigua, West
Indies
Griffiths, Victoria C., Cradley Heath, West
Midlands
Guiping Wu, Wuhan, Hubei, P.R. China

Gurevich, Lina, Finchley, London
Hedenskog, Elin M.S., London
Hessels, L.A., Schoonhoven, The Netherlands
Hirano, Kiyomi, Kawanishi City, Hyogo Pref.,
Japan
Hoff, J.S., Schoonhoven, The Netherlands
Hui Chau Ming, Kowloon, Hong Kong
Infuehr, Nicole C., Vienna, Austria
Ito, Ayako, Kyoto City, Kyoto, Japan
Jin Yanyan, Shanghai, P.R. China
Jinglei Bai, Wuhan, Hubei, P.R. China
Jose, Kadavi F., St Johns, Antigua, West Indies
Killingback, Harold, Oakham, Rutland
Lakshmi, Narayan S.S., Trichirapalli, India
Lam, Victoria L., Bolton-le-Sands, Carnforth,
Lancashire
Lam Kwi-Peng, Singapore
Lau Kam Yin, Mabel, Taipo, Hong Kong
Lee Ching, North Point, Hong Kong
Lee Chun Ming, New Territories, Hong Kong
Lee Kwok Wai, Joe, New Territories, Hong Kong
Lee Sui Kam, Monita, New Territories, Hong Kong
Lei Jiali, Guilin, Guangxi, P.R. China
Li Wing Chiu, Kowloon, Hong Kong
Liou Mun-Feng, Taipei, Taiwan, R.O. China
Longfei Gui, Wuhan, Hubei, P.R. China
Lu Ho Sheng, Taichung, Taiwan, R.O. China
Lui Sze-Wai, Alice, Quarry Bay, Hong Kong
McKinley, Karen, Abington, Northampton
Marlow, Carol, Sutton Coldfield, West Midlands
Middleton, Tara T., Toronto, Ontario, Canada
Mukhopadhyay, Nita, Kolkata, West Bengal, India
Nessi, Veroniki, Athens, Greece
Ning Jiao, Wuhan, Hubei, P.R. China
Ogden, Ben J., Harrogate, North Yorkshire
Oh Minkyung, Busan, South Korea
Pei Wang, Wuhan, Hubei, P.R. China
Peng Li, Wuhan, Hubei, P.R. China
Petkovic, Katarina, Surrey, BC, Canada
Phillips, Paul, Nuneaton, Warwickshire
Pitt, Sahra, Brockworth, Gloucestershire
Quinn, Elizabeth, Vista, California, U.S.A.
Rajap, Azeena, Eastbourne, East Sussex
Rantanen, Ari-Pekka, Hameenlinna, Finland
Roussou, Zoi K., Athens, Greece
Salt, Sebastian J., Salisbury, Wiltshire
Samarasekera, Prabha, Kandy, Sri Lanka
Sancheti, Amishaa, Indore, India
Schooling, Clare, London
Sikanen, Essi M., Lahti, Finland

Simonian, Siran, Krimpen a/d Ijssel, The Netherlands
 Somboon, Chaniya, Bangkok, Thailand
 Su Lin, Elizabeth, Shanghai, P.R. China
 Sun I-Ching, Tracy, Harrow, Middlesex
 Sun Bei, Shanghai, P.R. China
 Tennekoon, Indrani, Maida Vale, London
 Thanapatra, Jitsiri, Bangkok, Thailand
 Thein, Myint Myint, Willesden Green, London
 Thu, Latt Myat, Yangon, Myanmar
 Ting-Ju Lee, Christina (a), Yangon, Myanmar
 Tong Yung, Tony, Kowloon, Hong Kong
 Uberoi, Tina, Northwood, Middlesex
 Verma, Avneet, New Delhi, India
 Voutsinas, Dimistris, Athens, Greece
 Wachirusasawakul, Suvilai, Bangruk, Bangkok, Thailand
 Wei Shi, Wuhan, Hubei, P.R. China
 Wei Xiaoling, Guilin, Guangxi, P.R. China
 Whitehouse, Keith P., Stafford
 Williams, Adrienne V., London
 Wong Bick San, Patricia, North Point, Hong Kong
 Wong Tai-Wai, New Territories, Hong Kong
 Wu Mingyang, Shanghai, P.R. China
 Xiaoling He, Wuhan, Hubei, P.R. China
 Xin Xiongfeng, Shanghai, P.R. China
 Xu Banghui, Guilin, Guangxi, P.R. China
 Yan Zhou, Wuhan, Hubei, P.R. China
 Yao Tong, Wuhan, Hubei, P.R. China
 Yoshida, Naoshige, Osaka-City, Osaka, Japan
 Zar Aye Tin, Yangon, Myanmar
 Zhiqiang Liu, Wuhan, Hubei, P.R. China
 Zhou Fangfang, Bangkok, Thailand
 Ziyu Song, Wuhan, Hubei, P.R. China

Preliminary

Qualified

Adams, Stephen, Dorking, Surrey
 Aki, Miou, Osaka City, Osaka, Japan
 Andren, Stina E.M., Falsterbo, Sweden
 Andronikou, Stamatina, Manchester
 Anemogiannis, Spyridon, Athens, Greece
 Appleton, Susan E., Gillingham, Dorset
 Bagnall, Helen, Sheffield, South Yorkshire
 Bailey, Elaine, Stoke-on-Trent, Staffordshire
 Bergman, Marit, Uppsala, Sweden
 Bostock, Caroline, Antwerp, Belgium
 Brading, Kerry, Greenwich, London
 Bramwell, Gordon F.R., Kendal, Cumbria
 Canoel, Michelle, Lancaster
 Carnell, Sallie, Solihull, West Midlands
 Caron, Marie-Chantale, Montreal, Quebec, Canada
 Chan Lim Chi, Hong Kong
 Chen Chiao Yen, Taichung, Taiwan, R.O. China
 Chen Yi Chun, Taichung, Taiwan, R.O. China
 Cheng K.P., William, Hong Kong
 Cheung Ka Yiu, Harvey, Hong Kong
 Cheung Wing Man, Cynthia, Hong Kong
 Ching Mei Kit, Jennifer, Hong Kong
 Ching Chin Pang, Hong Kong
 Chohan, Tarun, Putnoe, Bedford
 Choi, Daeshik, Wimbledon Park, London
 Chookruvong, Kanjana, Bangkok, Thailand
 Conalty, Leo, Kilkenny, Ireland
 Cuba, Grant, San Angelo, Texas, U.S.A.
 Deprez, Guillaume, Roehampton, London
 Ferris, Edward W., Winchester, Hampshire
 Filadelfeos, Eleni-Anna, Athens, Greece
 Fisher, Abigail, London
 Fleming, Jane S., Glasgow, Scotland
 Fleming, John J., Glasgow, Scotland
 Fujii, Eiko, Harrow, Middlesex
 Goumaz, Benoit, Montreal, Quebec, Canada
 Guillaud, Pauline, Montreal, Quebec, Canada
 Halasz, Erika J., Zurich, Switzerland
 Henri, Martyne, Montreal, Quebec, Canada
 Hillstrom, Anders, Lannavaara, Sweden
 Holmes, Lissa, London
 Htun, Kahliar, Yangon, Myanmar
 Huang Shi, Jenny, Taichung, Taiwan, R.O. China
 Huang Dong, Guilin, Guangxi, P.R. China
 Hun Lai Chan, Hong Kong
 Inagaki, Yuko, London
 Kam Shuk Yi, Shummy, Hong Kong
 Kampanas, Christos, Athens, Greece
 Kan Ying, Cindy, Hong Kong
 Kandalepa, Theophano, Athens, Greece
 Kiamos, George, Athens, Greece
 Ko Man Wai, Hong Kong
 Konstantinidou, Maria, Athens, Greece
 Koyama, Yumika, Nagoya City, Aichi Pref., Japan
 Kuo Yaw Bao, Taichung, Taiwan, R.O. China
 Kwok Sau Mei, Halisa, Hong Kong
 Lacasse, Marie-Elise, Montreal, Quebec, Canada
 Lai Mei Oi, Emily, Hong Kong
 Lappin, Annette, Kilkenny, Ireland
 Lau Siu Ying, Emily, Hong Kong
 Law Cheuk Yee, Hong Kong
 Lee Hsiang Ju, Taichung, Taiwan, R.O. China
 Lee Fung Mei, Hong Kong
 Leung Suk Kay, Hong Kong
 Li Mo Ching, Hong Kong
 Li Xinyan, Guilin, Guangxi, P.R. China

Lo Heung Ling, Rosella, Hong Kong
McCaul, David A., Kilkenny, Ireland
McCrabbe, Julie, Hackney North, London
McMillan, Emma, Leamington Spa, Warwickshire
Manolia, Evgenia, Athens, Greece
Mathur, Chetna, Indore, India
Milton, Paul R., Liverpool
Morel, Francine, Montreal, Quebec, Canada
Munawar, Mirza S., Gothenburg, Sweden
Mutuma, Roy K., Nairobi, Kenya
Ng Chau Ping, Hong Kong
Nilsson, Annica H., Hong Kong
Nishitani, Yumi, Osaka City, Osaka, Japan
O'Connor, David W., Birmingham, West Midlands
Ohara, Yasuko, Nishinomiyama City, Hyogo Pref.,
Japan
Okada, Hiroko, Birmingham, West Midlands
Pang Chi Chung, Hong Kong
Pang, Bowen, Guilin, Guangxi, P.R.China
Papadopoulos, John, Athens, Greece
Parker, Carl J., Kilkenny, Ireland
Pearson, Isabel J., Reading, Berkshire
Petrozello, Ryan J., Randolph, NJ, U.S.A.
Plain, Lyndsey, Sheffield, South Yorkshire
Poon King Hong, Hong Kong
Poon Kit Ling, Hong Kong
Pornpilailuck, Anchalee, Bangkok, Thailand
Pradervand, Emilie, Montreal, Quebec, Canada
Redding, Collette, Yateley, Hampshire
Richmond, Sonia, London
Ross, Alexander J., Bath, Avon
Sai Kyaw Kyaw Win, Yangon, Myanmar
Sehgal, Neha, New Delhi, India
Shen, Shaoqin, Guilin, Guangxi, P.R. China
Shih Ming Nga, Hong Kong
Su Chen Hui, Taichung, Taiwan, R.O. China
Su Lin, Elizabeth, Bali, Indonesia
Takhar, Satwinder N. K., Telford, Shropshire
Tanaka, Yumi, Toyonaka City, Osaka, Japan
Thawanrat, R., Bangkok, Thailand
Tsang Yuen King, Hong Kong
Tsang Ka Hong, Hong Kong
Tsuor Wai Hing, Hong Kong
Tsutani, Miho, Osaka City, Osaka, Japan
Udomthanakij, Sorawut, Bangkok, Thailand
Verma, Avneet, New Delhi, India
Wilson, David E., Kilkenny, Ireland
Wong Man Nea, Rosemary, Hong Kong
Wong Ying, Hong Kong
Wordon, Valerie, Tarpoley, Cheshire
Wu Li Chen, Taichung, Taiwan, R.O. China

Xi Xing Shu, Shanghai, P.R. China
Xie Jing, Shanghai, P.R. China
Yasutake, Megumi, Shizuoka City, Japan
Ye Jing Yin, Shanghai, P.R. China
Yeung Ho Man, Hong Kong
Yu Yuen-Fun, Victoria, Hong Kong
Zaw Win Tun, Yangon, Myanmar
Zhou Wei Yong, Shanghai, P.R.China
Zhu Juntao, Guilin, Guangxi, P.R.China

MEMBERSHIP

Between 1 July and 1 October the Council of Management approved the election to membership of the following:

Diamond Membership (DGA)

Falnes, Lene, Hafslund, Norway, 2002
Pearson, Heather A., Belper, Derbyshire, 2002
Loo Shun Lee Andrew, Kwai Chung, Hong Kong,
1999
Yeung Yee Wai, Laguna City, Kwun Tong, Hong
Kong, 2002

Fellowship (FGA)

Basile, Appadoure, London, 2002
Dawson, Jane, London, 1982
Jinnam-olarn, Wichuda, Ampur Muang,
Udonthani, Thailand, 2002
Joyce, Sandra R., Maidstone, Kent, 1983
Li Wing Chiu, Kowloon, Hong Kong, 2002
Liao Chun-Yan, Taipei, Taiwan, R.O. China, 2001
Marlow, Carol, Sutton Coldfield, West Midlands,
2002
Morel, Francine, Ville Mont Royal, Quebec,
Canada, 2002
Pavaro, Thitintharee, Bangkok, Thailand, 2002
Quick, Fiona A., Francistown, Botswana, 1998
Rademakers-Boek, Gerriedina J., Weekst, The
Netherlands, 2002
Sakkaravej, Somruedee, Bangkok, Thailand, 2001
Sharma, Rashmi, Lusaka, Zambia, 2000
Shepherd, Louis, Long Eaton, Nottinghamshire,
1996
Thompson, Ian, Wood Green, London, 2000
Tсотros, Alexios, Athens, Greece, 1987
Wright Feng, Wendy E., Greenwood, Indiana,
U.S.A., 1990

Ordinary Membership

Andén, Lennart, Malmö, Sweden
Austin, Paul, West Drayton, Middlesex

Aw Soh Choo, Singapore
 Ayer, Elizabeth, Cambridge
 Banks, Jessica, London
 Barilits, Maria M., London
 Biggs, Fiona, Minchinhampton, Gloucestershire
 Blankson-Amankwah, Noble, London
 Bluestone, Anna, Hassocks, Brighton
 Bolamba, Tony Cassius, Romero, France
 Breuer, Lisa, London
 Cangelosi, Karen, St Louis, Missouri, U.S.A.
 Cheng, K.P. William, Ho Man Tin, Hong Kong
 Conejero, Jennifer H., Boston, Lincolnshire
 Curry, Stella C., Dartmouth, Devon
 Danon, Jerry, Bradford, West Yorkshire
 Dirir, Ahmed, London
 Domec, Cedric, Forest, Belgium
 Dunbar, Barry G., Islington, London
 Ecknauer, Marc, Wood Green, London
 Firmin, James H., Rutland, Leicestershire
 Fixley, Jonathan, Omaha, U.S.A.
 Gering, David, Tempe, Arizona, U.S.A.
 Graham, Michael R., Brentford, Middlesex
 Gregory, Nualchan, London
 Heber-Percy, Sophie, Drayton, Shropshire
 Holman, Meryan Janice, Truro, Cornwall
 Hornsby, Rebecca A., Spalding, Lincolnshire
 Hotson, Peter John, Berkhamsted, Hertfordshire
 Inagaki, Yuko, London
 Jackson, Antoinette, London
 Jain, Mayank, Lenton, Nottingham
 Jegaloua, Irina, Hounslow, Middlesex
 Katende, Laetitia, Waterside, Oxford
 Kebbay, Gifty K., London
 Kim, Junghyo, London
 Lambert, John K., Clowbridge, Burnley, Lancashire
 Landmark, Vivienne Jane, Harpenden,
 Hertfordshire
 Lee Young Ji, Ealing, London
 Muhandiramge, Shyam V.W., Walton-on-Thames,
 Surrey
 Pindar, Zoe Louise, Moortown, Leeds, West
 Yorkshire
 Pumphrey, Jessica K., Hammersmith, London
 Rupani, Nalina, Nairobi, Kenya
 Salt, Sebastian J., Salisbury, Wiltshire
 Samuels, Clinton, London
 Shaw, Sinead, London
 Shikatani, Kohei, Haverstock Hill, London
 Stephenson, Michelle, London
 Sykes-Gomez, Heidi, London
 Thompson, Jeff, Balcombe, West Sussex

Underwood, Thom, San Diego, California, U.S.A.
 Watanabe, Tomoko, London
 Wilkie, William, Dumbarton, Scotland
 Wild, Hans-Georg, Kirschweiler, Germany
 Yeung, John K.M., Harrow, Middlesex
 Zwordiak-Southall, Ania W., Old Warden,
 Bedfordshire

Laboratory Membership

Theo Fennell plc, 2B Pond Place, London SW3
 Benny Moussaieff, 45-46 New Bond Street,
 London W1

Transfers

Fellowship to Fellowship and Diamond Members (FGA DGA)

Avery, Hilary E., Bangor, Co. Down, N. Ireland
 Borruso, Alessandro, Harrow, Middlesex
 Clark, Antony, Bolton, Greater Manchester
 Croucher, Nicola, London
 Dimmick, Helen M., Pinner, Middlesex
 Donnelly, Lee-ona F., Heathfield, Ayr, Scotland
 Getgood, Fiona J., St Leonards on Sea, East Sussex
 Hassan, Fatima, Totteridge, London
 Oshida, Reiko, Singapore
 Pace, Howard M., Eccleshall, Stafford
 Pierotti, Moya A.M., London
 Plant, Monika, Knutsford, Cheshire
 Rweyemamu, Edward J., Leytonstone, London
 Salukvadze, Iamze, Dubai, United Arab Emirates
 Shah, Monica, Cheadle, Cheshire
 Sutton, Janine R., Harborne, Birmingham, West
 Midlands
 Toullie, Nathlie, Brentford, Middlesex
 Tuckwell, Alice E., Untersigenenthal, Switzerland
 Warner, Rachel F., London

Diamond Membership to Fellowship and Diamond Membership (FGA DGA)

Cristol, Agata, Marseille, France
 Falnes, Lene, Hafersjord, Norway

Ordinary Membership to Fellowship and Diamond Membership (FGA DGA)

Oh Minkyung, Busan, South Korea

Ordinary Membership to Fellowship (FGA)

Ashida, Eisuke, Kyoto City, Kyoto, Japan
 Berry, Susan, London
 Bertrand, Sylvia, Barcelona, Spain

Chohan, Tarun, Putnoe, Bedfordshire
 Choi, Daeshik, Wimbledon Park, London
 Chookruvong, Kanjana, Bangkok, Thailand
 Fujimoto, Akiko, Kotu City, Yamanashi Pref., Japan
 Govindarajulu, Suresh, St Johns, Antigua, West
 Indies

Gurevich, Lina, Finchley, London
 Hedenskog, Elin, London
 Hirano, Kiyomi, Kawanishi City, Hyogo Pref.,
 Japan

Ito, Ayako, Kyoto City, Kyoto, Japan
 Jose, Kadavi F., St Johns, Antigua, West Indies
 Killingback, Harold, Oakham, Rutland
 Lam, Victoria L., Bolton-le-Sands, Carnforth,
 Lancashire

Lam Kwi-Peng, Singapore
 McKinley, Karen, Abington, Northampton
 Quinn, Elizabeth, Vista, California, U.S.A.
 Salt, Sebastian J., Salisbury, Wiltshire
 Sun I-Ching, Tracy, Harrow, Middlesex
 Thein, Myint Myint, Willesden Green, London
 Towers, Jill S., St Heliers, Auckland, New Zealand
 Wachiruksasawakul, Suvilai, Bangruk, Bangkok,
 Thailand
 Yoshida, Naoshige, Osaka-City, Osaka, Japan

**Ordinary Membership to Diamond
 Membership (DGA)**

Anderson, Ian, Heaton, Bradford, West Yorkshire
 Arjan, Anand, East Ham, London
 Balls, Serra, London
 Daswani, Vijayeta, St Johns Wood, London
 Droujinina, Highgate, London
 Forbes-McCaig, Charlotte, Newtownabbey,
 Belfast, N. Ireland
 Leader, Lucille, London
 Loaker, Alistair, Stevenage, Hertfordshire
 Selvamani, Parvathi, Poplar, London
 St John Lewis, Delyth, Palmers Green, London
 Varnava, Sofia, Polihmi, Thessaloniki, Greece
 Wakefield, Dominic, Horsham, West Sussex

ISLAND OF GEMS

The 7th exhibition of the gems and gem industry of Sri Lanka is to be held in London on 16 and 17 November. The venue for this year's event is the Resource Centre, 356 Holloway Road, London N8 6PA (nearest underground Holloway Road). The exhibition will be divided into six units and there will be demonstrations of gem cutting and gem testing.

The entrance fee, which includes a souvenir brochure and a sample gemstone, is £3.00 (children under 12 years of age free of charge).

For further details contact Don Ariyaratna on 020 8807 8252; e-mail sri@lankagems.free-serve.co.uk website: www.lankagems.free-serve.co.uk

SUBSCRIPTIONS 2003

The following are the membership subscription rates for 2003. Existing Fellows, Diamond Members and Ordinary Members will be entitled to a £5.00 discount for subscriptions paid before 31 January 2003.

	<i>Fellows, Diamond Members and Ordinary Members</i>	<i>Laboratory members</i>
UK	£64.00	£250.00 + VAT
Europe	£70.00	£250.00
Overseas	£75.00	£250.00

**Pearls
 Gemstones**

Lapidary Equipment

GENOT L

Since 1953

**CH. De Wavre, 850
 B-1040 Bxl – Belgium**

**Tel : 32-2-647.38.16
 Fax : 32-2-648.20.26
 E-mail : gama@skynet.be**

**www.gemline.org
 www.geofana.net**

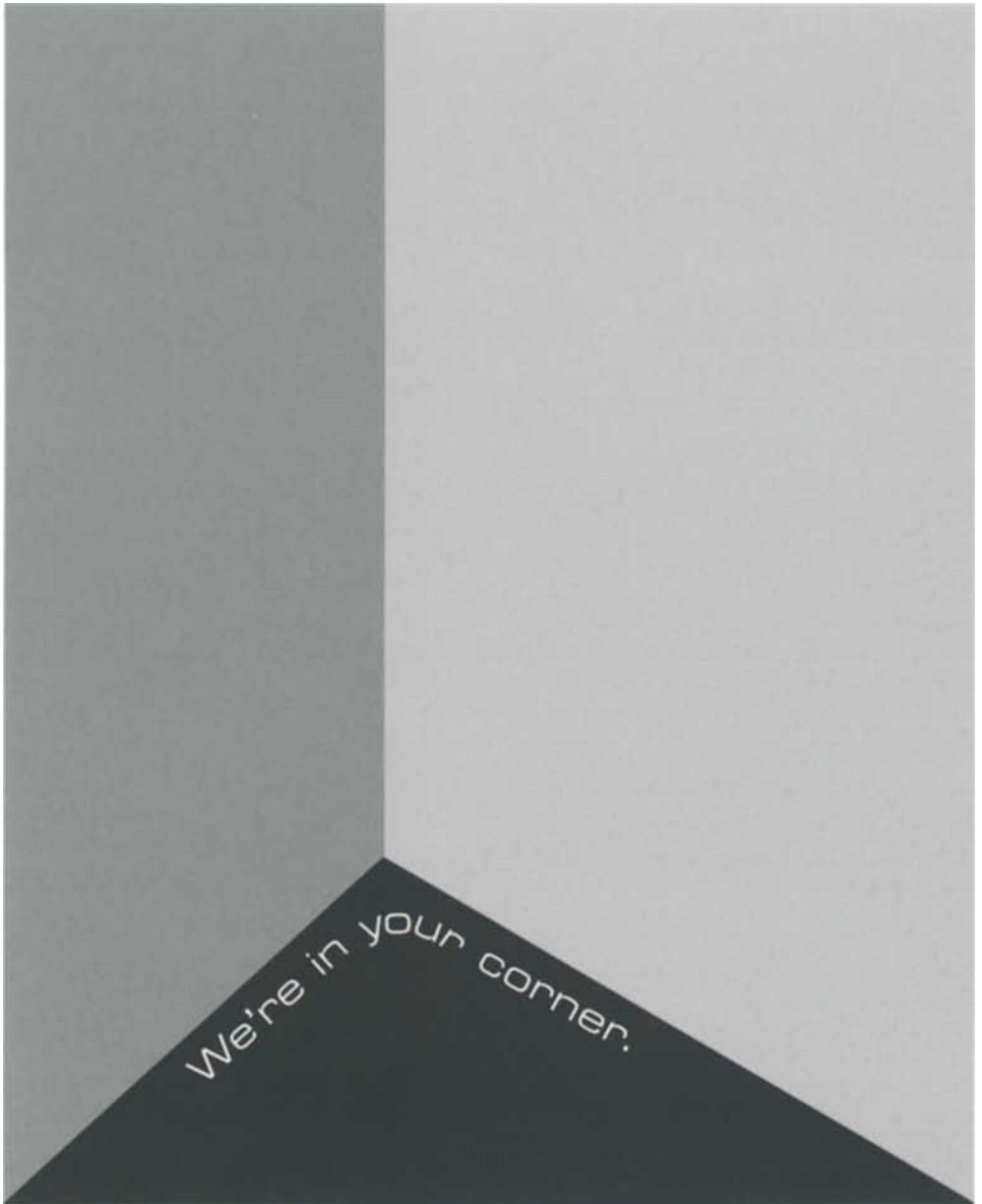

Barclays are proud to sponsor
the Gem-A Conference 2002.

Sue Chapman
99 Hatton Garden
London EC1N 8DN
Telephone: 020 7445 5154

BARCLAYS
FLUENT IN FINANCE

Pearls Coral Amber Bead Necklaces Carvings Cameos Mineral Specimens

The World



of Gemstones

Ruppenthal (U.K.) Limited

Gemstones of every kind, cultured pearls, coral, amber,
bead necklaces, hardstone carvings, objets d'art and
18ct gold gemstone jewellery.

We offer a first-class lapidary service.

By appointment only

1a Wickham Court Road, West Wickham, Kent BR4 9LN

Tel: 020-8777 4443, Fax: 020-8777 2321, Mobile: 07831 843287

e-mail: roger@ruppenthal.co.uk, Website: www.ruppenthal.co.uk

Modern 18ct Gem-set Jewellery

Opal Precious Topaz Ruby Star Ruby Sapphire Star Sapphire Tourmaline

Gemstones Aquamarine Alexandrite Amethyst Emerald Jade Lapis Lazuli

253

FELLOWS & SONS

Auctioneers & Valuers of Jewels, Silver & Fine Art

Established in 1876 Fellows & Sons are one of the UK's leading provincial auction houses, specialising in the sale and valuation of jewellery & watches, silver, furniture and collectables.

We hold over 30 auctions per annum of fine diamond and gem set jewellery; loose gemstones; memorial jewellery; novelties; and wrist and pocket watches, including Rolex, Piaget & Patek Phillippe.

Fully illustrated catalogues are available on our website

www.fellows.co.uk

and our Antique & Modern Jewellery & Watches auctions are available live on the internet to bidders around the world on

www.ebayliveauctions.com

Contact us now for further information on our services.

Augusta House, 19 Augusta Street, Hockley, Birmingham B18 6JA

Tel: 0121 212 2131 Fax: 0121 212 1249



**Museums,
Educational Establishments,
Collectors & Students**

I have what is probably the largest range of genuinely rare stones in the UK, from Analcime to Wulfenite. Also rare and modern synthetics, and inexpensive crystals and stones for students. New computerised lists available with even more detail. Please send £2 in 1st class stamps refundable on first order (overseas free).

Two special offers for students:

New Teach/Buy service and free stones on an order.

A.J. French, FGA
82 Brookley Road, Brockenhurst,
Hants SO42 7RA
Telephone: 01590 623214

**PROMPT
LAPIDARY
SERVICE!**

Gemstones and diamonds cut to your specification and repaired on our premises.

Large selection of gemstones including rare items and mineral specimens in stock.

Valuations and gem testing carried out.
Mail order service available.

R. HOLT & CO. LTD

98 Hatton Garden, London EC1N 8NX
Telephone 020-7405 0197/5286
Fax 020-7430 1279

**ROCK
'n' gem
SHOWS**

**Exhibitors Displaying & Selling
*Treasures of the Earth***

2002

HATFIELD HOUSE

Hatfield, Herts (Junction 4 of A1(M))

26-27 OCTOBER *

**KEMPTON PARK
RACECOURSE**

Sunbury on Thames, Middx (A308)

2-3 NOVEMBER **

**UTTOXETER
RACECOURSE**

Uttoxeter, Staffordshire

23-24 NOVEMBER

2003

THE HOP FARM

Beltring, Paddock Wood, Kent

18-19 JANUARY

*All shows are indoors and open 10am - 5pm
Refreshments ~ Free Parking
Wheelchair Access*

2002 Admissions:

Adults £2.50/*£2.25/**£3.00

Seniors £2.00/*£1.75/**£2.50

Children (8-16 yrs) £1.00

THE EXHIBITION TEAM LTD 01628 621697

Email: info@rockngem.co.uk

www.rockngem.co.uk

Before you
choose your
insurance make sure
you read the small print



At T.H. March, every insurance package we supply is backed by an experience no one else can match. For over a hundred years we have provided the expertise, reliability and quality of service which has made us the premier insurance broker to the jewellery trade.



London 10/12 Ely Place, London EC1N 6RY
Tel 020 7405 0009 Fax 020 7404 4629
web www.thmarch.co.uk email insurance@thmarch.co.uk

Additional offices in:

Birmingham 10A Vyse Street, Hockley, B18 6LT
Tel 0121 236 9433 Fax 0121 233 4901

Glasgow Empire House, 131 West Nile Street, G1 2RX
Tel 0141 332 2848 Fax 0141 332 5370

Manchester 1st Floor, Paragon House, Seymour Grove, M16 0LN
Tel 0161 877 5271 Fax 0161 877 5288

Plymouth Hare Park House, Yelverton Business Park, Yelverton PL20 7LS
Tel 01822 855555 Fax 01822 855566

Sevenoaks Sackville House, 55 Buckhurst Avenue, Kent TN13 1LZ
Tel 01732 462886 Fax 01732 462911



FORTHCOMING EVENTS

Gem-A Conference 2002

To be held on

Sunday 3 November

at **Kempton Park Racecourse, Sunbury on Thames, Middx.**

In conjunction with the Rock 'n' Gem Show

Speakers:

Professor Dr Edward J. Gübelin

Professor Andrew Rankin

Dr Robert Symes OBE

Stephen Webster

ADDITIONAL CONFERENCE EVENTS

Visits to the DTC

Private viewing and tour of the *Crown Jewels* with Crown Jeweller David Thomas

Curatorial tour of 'The Jewels of JAR, Paris' exhibition at Somerset House

- 4 November **Presentation of Awards and Reunion of Members.**
Goldsmiths' Hall, Foster Lane, London EC2.
- 17 November **South West Branch.** *Trick or Treat.* An afternoon of talks and practical gemmology.
- 19 November **Scottish Branch.** *The Crown Jewels. E. ALAN JOBBINS.*
- 20 November **North West Branch.** AGM and social evening.
- 29 November **Midlands Branch.** *Fabulous Fabergé expert, auctioneer and buyer.*
STEPHEN DALE
- 7 December **Midlands Branch.** Celebration 50th Anniversary Dinner.
- 8 December **South East Branch.** Inaugural meeting. *Gemstones at auction.*
DAVID LANCASTER. Followed by private viewing of Jewellery Sale at Christie's, South Kensington

Contact details

- (when using e-mail, please give Gem-A as the subject):
- London:** Mary Burland on 020 7404 3334; e-mail gagtl@btinternet.com
- Midlands Branch:** Gwyn Green on 0121 445 5359; e-mail gwyn.green@usa.net
- North West Branch:** Deanna Brady on 0151 648 4266
- Scottish Branch:** Catriona McInnes on 0131 667 2199; e-mail scotgem@blueyonder.co.uk
- South East Branch:** Colin Winter on 01372 360290
- South West Branch:** Bronwen Harman on 01225 482188; e-mail bharman@harmanb.freeserve.uk

Gem-A Website

For up-to-the-minute information on Gem-A events visit our website on www.gem-a.info

Guide to the preparation of typescripts for publication in *The Journal of Gemmology*

The Editor is glad to consider original articles shedding new light on subjects of gemmological interest for publication in *The Journal*. Articles are not normally accepted which have already been published elsewhere in English, and an article is accepted only on the understanding that (1) full information as to any previous publication (whether in English or another language) has been given, (2) it is not under consideration for publication elsewhere and (3) it will not be published elsewhere without the consent of the Editor.

Typescripts Two copies of all papers should be submitted on A4 paper (or USA equivalent) to the Editor. Typescripts should be double spaced with margins of at least 25 mm. They should be set out in the manner of recent issues of *The Journal* and in conformity with the information set out below. Papers may be of any length, but long papers of more than 10 000 words (unless capable of division into parts or of exceptional importance) are unlikely to be acceptable, whereas a short paper of 400–500 words may achieve early publication.

The abstract, references, notes, captions and tables should be typed double spaced on separate sheets.

Title page The title should be as brief as is consistent with clear indication of the content of the paper. It should be followed by the names (with initials) of the authors and by their addresses.

Abstract A short abstract of 50–100 words is required.

Key Words Up to six key words indicating the subject matter of the article should be supplied.

Headings In all headings only the first letter and proper names are capitalized.

A **This is a first level heading**

First level headings are in bold and are centred on a separate line.

B *This is a second level heading*

Second level headings are in italics and are flush left on a separate line.

Illustrations Either transparencies or photographs of good quality can be submitted

for both coloured and black-and-white illustrations. It is recommended that authors retain copies of all illustrations because of the risk of loss or damage either during the printing process or in transit.

Diagrams must be of a professional quality and prepared in dense black ink on a good quality surface. Original illustrations will not be returned unless specifically requested.

All illustrations (maps, diagrams and pictures) are numbered consecutively with Arabic numerals and labelled Figure 1, Figure 2, etc. All illustrations are referred to as 'Figures'.

Tables Must be typed double spaced, using few horizontal rules and no vertical rules. They are numbered consecutively with Roman numerals (Table IV, etc.). Titles should be concise, but as independently informative as possible. The approximate position of the Table in the text should be marked in the margin of the typescript.

Notes and References Authors may choose one of two systems:

(1) The Harvard system in which authors' names (no initials) and dates (and specific pages, only in the case of quotations) are given in the main body of the text, (e.g. Collins, 2001, 341). References are listed alphabetically at the end of the paper under the heading References.

(2) The system in which superscript numbers are inserted in the text (e.g. ... to which Collins refers.³) and referred to in numerical order at the end of the paper under the heading Notes. Informational notes must be restricted to the minimum; usually the material can be incorporated in the text. If absolutely necessary both systems may be used.

References in both systems should be set out as follows, with *double spacing* for all lines.

Papers Collins, A.T., 2001. The colour of diamond and how it may be changed. *J.Gemm.*, 27(6), 341–59

Books Balfour, I., 2000. *Famous diamonds*. 4th edn. Christie's, London. p. 200

Abbreviations for titles of periodicals are those sanctioned by the *World List of scientific periodicals* 4th edn. The place of publication should always be given when books are referred to.



Contents

Development of concave faceting of gemstones	193
<i>A.D. Morgan</i>	
Doubling of images in gemstones	210
<i>D.B. Sturman and M.E. Back</i>	
Birefringence vs. double refraction divergence	223
<i>R. Cartier</i>	
Verneuil synthetic sapphire showing an iron absorption spectrum	227
<i>J.M. Duroc-Danner</i>	
A note on two star stones	231
<i>R.R. Harding</i>	
Gem-quality spessartine-grossular garnet of intermediate composition from Madagascar	235
<i>K. Schmetzer and H.-J. Bernhardt</i>	
Letter to the Editor	239
Proceedings of the Gemmological Association and Gem Testing Laboratory of Great Britain and Notices	240

Copyright © 2002

The Gemmological Association and
Gem Testing Laboratory of Great Britain

Registered Office: Palladium House, 1-4 Argyll Street, London W1V 2LD